



505.73

187 14

178
72 300

THE
AMERICAN
JOURNAL OF SCIENCE.

EDITOR: EDWARD S. DANA.

ASSOCIATE EDITORS

PROFESSORS GEO. L. GOODALE, JOHN TROWBRIDGE,
W. G. FARLOW AND WM. M. DAVIS, OF CAMBRIDGE,

PROFESSORS A. E. VERRILL, HENRY S. WILLIAMS AND
L. V. PIRSSON, OF NEW HAVEN.

PROFESSOR GEORGE F. BARKER, OF PHILADELPHIA,
PROFESSOR JOSEPH S. AMES, OF BALTIMORE,
MR. J. S. DILLER, OF WASHINGTON.

FOURTH SERIES.

VOL. XII—[WHOLE NUMBER, CLXII.]

WITH NINE PLATES.

NEW HAVEN, CONNECTICUT.

1901.



THE TUTTLE, MOREHOUSE & TAYLOR COMPANY,
NEW HAVEN, CONN.



CONTENTS TO VOLUME XII.

Number 67.

	Page
ART. I.—Geology of the Shonkin Sag and Palisade Butte Laccoliths in the Highwood Mountains of Montana; by W. H. WEED and L. V. PIRSSON	1
II.—Manganese Ore Deposits of the Queluz (Lafayette) District, Minas Geraes, Brazil; by O. A. DERBY	18
III.—Bituminous Deposits situated at the South and East of Cárdenas, Cuba; by H. E. PECKHAM	33
IV.—Mineralogical Notes, No. 2; by A. F. ROGERS	42
V.—New Solution for the Copper Voltmeter; by W. K. SHEPARD	49
VI.—Thermo-magnetic and Galvano-magnetic Effects in Tellurium; by M. G. LLOYD	57
VII.—Additions to the Avifauna of the Bermudas with diagnoses of two new Subspecies; by A. H. VERRILL ...	64
VIII.—Induced Alternating Current Discharge studied with Reference to its Spectrum and especially the Ultra-Violet Spectrum; by A. W. WRIGHT and E. S. DOWNS	66

SCIENTIFIC INTELLIGENCE.

Chemistry and Physics—Ignition temperature of Phosphorus, EYDMAN: Composition of "Caro's Acid," BAEYER and VILLIGER, 73.—Vitrified Quartz, SHENSTONE, 74.—Influence of Magnetism upon Superaturated Solutions, DE HEMPTINNE: Ammonium Cyanate, WALKER and WOOD: Selenium in Sulphuric Acid, JOUVE, 75.—Qualitative Chemical Analysis: Viscosity of Argon, SCHULTZE: Conductivity in Hydrogen and Carbonic Acid Gas, TOWNSEND and KIRKBY: E.M.F. of Clark- and Weston-Cell, JAEGER and LINDECK, 76.—Electrical Flow in Gases, STARK: Treatise on Electro-Magnetic Phenomena, LYONS, 77.

Geology and Natural History—Eocene Deposits of Maryland, and Systematic Paleontology, 77.—Annual Report Geol. Survey Arkansas, 1892, 78.—Summary Report Geol. Survey Canada, 1900: Revision of Genera and Species of Canadian Paleozoic Corals, LAMBE, 79.—Amygdaloidal Melaphyre in Mass., BURR, 80.—Explosive Activity of Vesuvius, MATEUCCI: Der Vulcan Etinde in Kamerun und seine Gesteine, ESCH, 81.—Söndre Helgeland, VOGT, 82.—Classification of Igneous Rocks, FEDEROW, 83.—Boletin del Instituto Geologico de Mexico: Brief Notices of recently described Minerals, 84.—Iron Meteorites, 86.—Milchsaft und Schleimsaft der Pflanzen. MOLISCH, 87.—Remarkable Instance of Death of Fishes at Bermuda, VERRILL, 88.

Miscellaneous Scientific Intelligence—Atlas Meteorologico de la Republica Argentina, 88.—British Museum Catalogues: Select Bibliography of Chemistry, 1492-1897: Publications Bureau of American Ethnology: Field Columbian Museum: Scientia, 89.—Zoologisches Addressbuch: Publications Earthquake Investigating Committee; Publications U. S. Naval Observatory, 90.

Number 68.

	Page
ART. IX.—Experiments on High Electrical Resistance, Part II; by O. N. ROOD	91
X.—Mineralogical Notes; by A. J. MOSES	98
XI.—Motion of Compressible Fluids; by J. W. DAVIS.....	107
XII.—Action of Sodium Thiosulphate on Solutions of Metallic Salts at High Temperatures and Pressures; by J. T. NORTON, JR.	115
XIII.—Secondary Undulations Shown by Recording Tide-gauges; by A. W. DUFF	123
XIV.—Mathematical Notes to Rival Theories of Cosmogony; by O. FISHER.....	140
XV.—Studies of Eocene Mammalia in the Marsh Collection, Peabody Museum; by J. L. WORTMAN.....	143
XVI.—Electromagnetic Effects of Moving Charged Spheres; by E. P. ADAMS	155
XVII.—The Nadir of Temperature and Allied Problems; by J. DEWAR	168

SCIENTIFIC INTELLIGENCE.

Miscellaneous Scientific Intelligence—Magnetic effect of Electrical Convection, H. PENDER, 173.—American Association for the Advancement of Science, 174.

Obituary.—DR. JOSEPH LECONTE: PROFESSOR PETER GUHTRIE TAIT, 174.

Number 69.

	Page
ART. XVIII.—Discharge-current from a Surface of large Curvature; by J. E. ALMY	175
XIX.—Octahedrite and Brookite, from Brindletown, North Carolina; by H. H. ROBINSON	180
XX.—Behavior of Small closed Cylinders in Organ-pipes; by B. DAVIS	185
XXI.—Cæsium-Tellurium Fluoride; by H. L. WELLS and J. M. WILLIS	190
XXII.—Double Chlorides of Cæsium and Thorium; by H. L. WELLS and J. M. WILLIS	191
XXIII.—Studies of Eocene Mammalia in the Marsh Collection, Peabody Museum; by J. L. WORTMAN	193
XXIV.—Separation of the Least Volatile Gases of Atmospheric Air, and their Spectra; by G. D. LIVEING and J. DEWAR	207
XXV.—Estimation of Calcium, Strontium, and Barium, as the Oxalates; by C. A. PETERS	216
XXVI.—Calaverite; by S. L. PENFIELD and W. E. FORD	225

SCIENTIFIC INTELLIGENCE.

Miscellaneous Scientific Intelligence—Temporary Set, C. BARUS: Some new rock-types, 247.

Obituary—JOSEPH LECONTE, 248.

Number 70.

	Page
ART. XXVII.—Galvanometers of High Sensibility; by C. E. MENDENHALL and C. W. WAIDNER	249
XXVIII.—Method of Locating Nodes and Loops of Sound in the Open Air with Applications; by B. DAVIS.	263
XXIX.—Anatomy of the Fruit of <i>Cocos nucifera</i> ; by A. L. WINTON	265
XXX.—Studies of Eocene Mammalia in the Marsh Collection, Peabody Museum; by J. L. WORTMAN. With Plates I-IV	281
XXXI.—Crinoid from the Hamilton of Charlestown, Indiana; by E. WOOD. With Plate V	297
XXXII.—Estimation of Cæsium and Rubidium as the Acid Sulphates, and of Potassium and Sodium as the Pyrosulphates; by P. E. BROWNING	301
XXXIII.—Time Values of Provincial Carboniferous Terranes; by C. R. KEYES	305
XXXIV.—Spectra of Hydrogen and some of its Compounds; by J. TROWBRIDGE. With Plate VI.	310

SCIENTIFIC INTELLIGENCE.

Chemistry and Physics—Induced Radio-activity produced by Salts of Radium. P. CURIE and A. DEBIERNE, 319.—New Method of Quantitative Analysis, R. W. THATCHER, 320.—Europium, a New Element, DEMARÇAY: Research Papers from the Kent Chemical Laboratory of Yale University, F. A. GOOCH, 321.—Magnetic Effect of Electrical Convection, H. A. WILSON: Effect of Amalgamated Gases on Resistance, W. ROLLINS, 322.

Miscellaneous Scientific Intelligence—American Association, 323.—British Association: Catalogue of the African Plants collected by Dr. F. Welwitsch in 1853-61: Vol. II, Part II, Cryptogamia: Leitfaden der Wetterkunde, gemeinverständlich bearbeitet, R. BÖRNSTEIN, 324.—Studien über die Narkose, E. OVERTON: Ueber Harmonie und Complication, V. GOLDSCHMIDT: Nature's Miracles, Familiar Talks on Science, E. GRAY, 325.

Obituary—CHARLES ANTHONY SCHOTT: BARON ADOLF ERIC NORDENSKIÖLD: DR. WILHELM SCHUR: BARON DE LACAZE-DUTHIERS, 326.

Number 71.

	Page
ART. XXXV.—Effect of Temperature and of Moisture on the Emanation of Phosphorus, and on a Distinction in the Behavior of Nuclei and of Ions ; by C. BARUS.....	327
XXXVI.—Determination of the Heat of Dissociation and of Combustion of Acetylene, Ethylene and Methane ; by W. G. MIXTER.....	347
XXXVII.—Geological Relations and the Age of the St. Joseph and Potosi Limestones of St. François County, Missouri ; by F. S. NASON.....	358
XXXVIII.—Cambrian Fossils of St. François County, Missouri ; by C. E. BEECHER.....	362
XXXIX.—Discovery of Eurypterid Remains in the Cambrian of Missouri ; by C. E. BEECHER. With Plate VII	364
XL.—Determination of Persulphates ; by C. A. PETERS and S. E. MOODY.....	367
XLI.—Studies of Eocene Mammalia in the Marsh Collection, Peabody Museum ; by J. L. WORTMAN.....	377
XLII.—Carboniferous and Permian Age of the Red Beds of Eastern Oklahoma from Stratigraphic Evidence ; by G. I. ADAMS.....	383

SCIENTIFIC INTELLIGENCE.

Chemistry and Physics—New Method for Producing Aniline and the Analogous Bases, SABATIER and SENDERENS: Existence of Ammonium, O. RUFF, 387.—Modified Gooch-Crucible, W. C. HERAEUS: Radio-active Lead, HOFMANN and STRAUSS, 388.—Salt of Quadrivalent Antimony, WELLS and METZGER: New Method for the Gravimetric Determination of Tellurium, GUTBIER: Diffusion of Hydrogen through Palladium, A. WINKELMANN: Cathode Rays, W. SEITZ, 389.—Photography of the Infra-Red Spectra of the Alkali-metals, H. LEHMANN: Ether and Gravitational Matter through Infinite Space, LORD KELVIN, 390.—Nineteenth Century Cloud over the Dynamical Theory of Heat and Light, LORD KELVIN, 391.—Resistance and Electromotive forces of the Electric Arc, W. DUELDEL, 392.—Unsolved Problems in Low-Temperature Research, A. M. CLERKE, 393.

Geology and Mineralogy—Geological Survey of Canada, G. M. DAWSON, 394.—Geological Survey of Canada, R. BELL and J. F. WHITEAVES: Geological and Natural History Survey of Minnesota, 1900–1901, N. H. WINCHELL, 395.—Iowa Geological Survey, S. CALVIN: Dragons of the Air, an account of Extinct Flying Reptiles, H. G. SEELEY, 396.—Contributions to Mineralogy and Petrography from the Laboratories of the Sheffield Scientific School of Yale University, S. L. PENFIELD and L. V. PIRSSON: Large Phlogopite Crystal, W. H. MCNAIRN, 398.—Handbuch der Mineralogie, C. HINTZE, 399.

Miscellaneous Scientific Intelligence—Meteorite Swarms, A. G. HÖGBOM, 399.—American Philosophical Society of Philadelphia, 400.

Number 72.

	Page
ART. XLIII.—Geology of the Little Colorado Valley; by L. F. WARD.....	401
XLIV.—Pyrite and Marcasite; by H. N. STOKES	414
XLV.—Studies of Eocene Mammalia in the Marsh Collection, Peabody Museum; by J. L. WORTMAN. With Plates VIII and IX	421
XLVI.—Dielectric Constant of Paraffins; by W. G. HORMELL	433
XLVII.—New Mineral Occurrences in Canada; by G. C. HOFFMANN	447
XLVIII.—Estimation of Molybdic Acid reduced by Hydriodic Acid; by F. A. GOOCH and O. S. PULMAN, JR.	449
XLIX.—Veramin Meteorite, by H. A. WARD	453

SCIENTIFIC INTELLIGENCE

Chemistry and Physics—Double Compounds of Antimony Pentachloride, etc., ROSENHEIM and STELLMANN: Thermochemistry of Alloys, T. J. BAKER: Acid Nitrates, WELLS and METZGER, 460.—Methods of Standardizing Acid Solutions, C. G. HOPKINS, 461.—New Element Associated with Thorium, C. BASKERVILLE: Laboratory Guide to the Study of Qualitative Analysis, E. H. S. BAILEY and H. P. CADY: Elements of Qualitative Analysis, W. A. NOYES, 462.—Heterogene Gleichgewichte von Standpunkte der Phasenlehre, H. W. B. ROOZEBOOM: Viscosity of Helium, H. SCHULTZE: Air-tight glass stop-cocks, H. THIELE and M. ECKARDT: Migration of the ions, R. GANS, 463.—Photometry of the Ultra-Violet rays, H. KREUSLER, 464

Geology and Mineralogy—Glaciation in Tierra del Fuego and in the Antarctic, H. ARCTOWSKI, 464.—Glaciers of Switzerland in 1900, S. FINSTERWALDER and E. MURET: United States Geological Survey, C. D. WALCOTT, 465.—Indiana: Department of Geology and Natural Resources, W. S. BLATCHLEY: Geological Survey of New Jersey, Annual Report, 1900: Ice Ramparts, E. R. BUCKLEY, 466.—Syllabus of a Course of Lectures on Elementary and Economic Geology, J. C. BRANNER and J. F. NEWSOM: Loess of Iowa City and Vicinity, B. SHIMEK: River System of Connecticut, W. H. HOBBS: Sivamalai Series of Eleolite-Syenites and Corundum-Syenites in the Coimbatore Distr., Madras Presidency, T. H. HOLLAND, 467.—Peculiar Form of altered Peridotite, T. H. HOLLAND: Perknite, H. W. TURNER, 468.—Outline of Elementary Lithology, G. H. BARTON: Synchisite and Molybdophillite: Crystallization of Stannite, L. J. SPENCER: Conchite and Ktypteite, H. VATER: Meteorite of Felix, Perry County, Alabama, G. P. MERRILL, 469.

Zoology—Nomenclature of Bermuda Birds, A. H. VERRILL, 470.—Reports on the Fauna of Porto Rico, 471.—Papers from the Alaska Harriman Expedition, W. R. COE: Zoölogy: An Elementary Text Book, A. E. SHIPLEY and E. W. MACBRIDE: Elementary Course of Practical Zoölogy, T. J. PARKER and W. N. PARKER, 472.

Miscellaneous Scientific Intelligence—National Academy of Sciences, 472—Annual Report of the Board of Regents of the Smithsonian Institution, for the year ending June 30, 1900: Smithsonian Institution: Documents relative to its Origin and History, 1835-1899, W. J. RHEES, 473.—Beiträge zur chemischen Physiologie und Pathologie: Annals of Harvard College Observatory, E. C. PICKERING: Royal Society of London, Copley Medal, 474.

Obituary—RUDOLPH KOENIG: PROFESSOR A. F. W. SCHIMPER, 474.

T H E

AMERICAN JOURNAL OF SCIENCE

[FOURTH SERIES.]

ART. I.—*Geology of the Shonkin Sag and Palisade Butte
Laccoliths in the Highwood Mountains of Montana*; by
W. H. WEED and L. V. PIRSSON.*

Introductory.—On the southeast side of the Highwood Mountains, the open treeless plains country which stretches away in all directions from the foot of the broken volcanic hills of tuffs and lava, has its monotony interrupted by a tract of broken and sharply accidented character. Although separated from the rest of the mountain group by certain geological features not elsewhere seen and by its outlying position, it is nevertheless an integral portion of the Highwood eruptive area since it belongs to the same geologic period of eruptive activity and is merely a prolongation of the eruptive masses in this direction, separated, like the rest of the mountains, from the other igneous groups of central Montana by wide stretches of sedimentary rocks which are undisturbed by such intrusions.

This area is terminated and its accidented character accentuated by the deep trench-like valley which Arrow River has scored in the plain and where, in the deeply carved band of badlands which decorates its margin, are revealed the particolored strata of the level-lying Cretaceous.

Topographically and scenically, this region is characterized by the dark frowning masses of Square and Palisade Buttes, which form such prominent landmarks across the level horizon and weary miles of the vast open prairies, and by the debouchement of the shallow valley of the Shonkin Sag, elsewhere described, into that of the Arrow River; while minor features

* By permission of the Director of the U. S. Geological Survey.

are the deep erosion of the margins of the valleys into badlands, of those of the igneous masses into fantastic rock piles, and the many heavy, black dike walls which cross the open stretches or form buttresses along the slopes.

A petrographical description of the sodalite-syenite of Square Butte by Lindgren and Melville* is the first publication relating to the geology of this part of the Highwood Mts. area which has come to our attention. Its geology and petrography have been fully described by the writers in a later paper,† and the geology of the area as mapped by the authors has been published in the Fort Benton Folio of the Geologic Atlas of the United States accompanied by text briefly describing the geology by Mr. Weed.

Geologically the area differs from that of the rest of the Highwoods in that it is one of intrusion devoid of extrusive igneous masses. The evidence at hand does not show

that here the magmas ever attained the surface and produced volcanic outbreaks; if such occurred, the extrusive material has long since been swept away by erosion and the facts point rather to the view that this has not occurred.

The igneous masses are divided into the Square Butte, Palisade Butte, and the Shonkin Sag laccoliths, and the dikes and intrusive sheets, as seen on the map figure 1.

Although topographically and in size it is the least of the laccoliths and, at first sight, of the least importance,

we shall commence with an account of the Shonkin Sag laccolith for the reason that geologically it is the most important and supplies the key to certain features which they all possess in common. Moreover, it is in several features and in the character of its dissection by erosion one of the most perfect laccoliths that has been described, and its internal structure is such as to render it an occurrence of great importance in theoretic petrology.



1 Syenite. 2 Shonkinite. 3 Cretaceous. 4 Dikes and sheets.

FIG. 1. Map of Laccoliths.

* This Journal, vol. xlv, 1893, p. 289.

† Bull. Geol. Soc. of America, vol. vi, 1895, pp. 389-422.

The Shonkin Sag Laccolith.

Where the Shonkin Sag valley debouches into that of Arrow River it has a wide and open character with walls of sloping debris or deeply carved Cretaceous strata. It is cut by several small streams of excellent water which burst out as springs under the base of Square Butte and find their way into Arrow River. Through the middle of the level valley floor wander the alkaline waters of Flat Creek with feeble, sluggish current, dried away in summer to standing pools. It is crossed by the stage road from Benton to Lewistown, and on the open flat stand the buildings of the relay stage station.

Proceeding from here up the valley in a westerly direction, at first the heavy mass of Square Butte above and to the left dominates the scene, and in the sandstones upon which it rests are seen intruded sheets of black basaltic rock. About a mile or so to the west appears on the left an intrusive mass of dark colored shonkinite which rises in a cliff wall over a hundred feet in height, the talus from whose foot slopes down to the valley floor. This wall is not more than a few hundred yards in length and the intrusion seems to be clearly a separate one from that of Square Butte and the Shonkin Sag laccolith. Where its contact is seen, it cuts abruptly through the light colored sandstones. It has a quite distinct columnar structure and although evidently not a typical or symmetrical laccolith, so far as one can judge from the exposures seen, it is clearly a small intrusion of laccolithic character.

On the opposite, the northern and eastern, side of the valley several dikes of basaltic rock are seen cutting the sandstone wall; then an intruded sheet appears in the sediments above the talus slopes. This persists, and following it a turn in the valley reveals the front wall face of the Shonkin Sag laccolith. From the opposite side of the valley, whose width is here sufficient, an excellent view of it is obtained, and it is seen as a long columnar cliff stretching for a distance of about one mile, and with a quite even and regular face, interrupted at about the middle by a deep canyon-like gulch which cuts down through the whole thickness of the cliff at this point. The columnar structure is quite pronounced, the polygonal columns having a diameter of a couple of feet or more, and in length, that is in height, they were estimated to be over one hundred feet, which measures the thickness of the laccolith along the cliff front. Below, all along the front, the laccolith is seen resting on the light brown Cretaceous sandstones which form the floor upon which it lies. They are quite horizontal and the regular even level of this floor is very noticeable. From the foot of the cliff a great talus descends down to the

valley floor; it is not an even regular sheet of detritus but is carved down at rather regular intervals by rain-washed gulches and raised at the points between by a more abundant supply of materials, so that it presents the appearance of a rude series of intersecting half cones or steep fans resting against the cliff wall of the valley. The surface of these talus cones is generally grassed over, giving a rather smooth appearance, but they are elsewhere covered with large blocks of rock from the



FIG. 2. Cliff wall of Shonkin Sag laccolith. Dissecting gulch to left over standing figure.

great columns of the cliff above, which have broken down and whose pieces have rolled down the slopes. At the apices of the cones the material reaches nearly or up to the foot of the columns, and the sandstones of the laccolith floor are in places nearly concealed, but in the intervening gulches a considerable thickness of them is seen. On top of the laccolith are seen resting the Cretaceous sandstones into which it is intruded in horizontal, unbroken position. Their thickness is variable as from each end of the cliff-wall it gradually diminishes until about the middle, where the laccolith is cut by the intersecting gulch, they disappear, leaving, especially on the eastern side, a portion of the top of the laccolith bared. On the opposite side of the gulch, however, a considerable thickness of them is seen resting on top of the columns of igneous rock.

Ends of the Laccolith Wall.—From what has been said above, it is clear that this cliff wall is the cross section of a flat mass intruded into and lying between the beds of sandstone, its laccolithic character being seen only at the outer borders. No real distinction can be drawn which will separate laccoliths from intrusive sheets: the most typical laccolith can be regarded as a very short, thick, domed sheet, and conversely, an intrusive sheet can be regarded as a very flat, thin laccolith. In our work in the mountain areas of central Montana, we have observed all degrees of transition between the two. Nevertheless, in the typical laccolith we presuppose a certain, quick up-arching of the strata which we do not observe in the typical intrusive sheet.

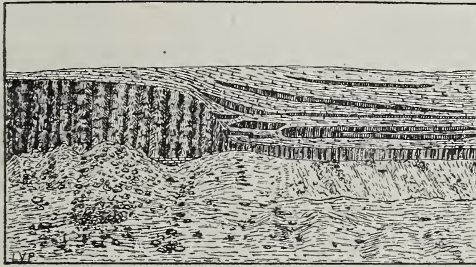

FIG. 3. Sketch of east end of laccolith showing relations of strata and intruded sheets.

This character is well shown by the Shonkin laccolith at the eastern end. The main body of the laccolith rounds quickly down at a pretty sharp angle until it becomes only the thin intrusive sheet, previously mentioned, not more than ten feet in thickness, which on the same horizon extends a great distance out into the sandstones. Besides this main lower fringing sheet there are two or three lesser ones which do not extend far and quickly die away in the sedimentary beds, and in addition, at the spring of the demi-arch of sandstones, where there must have been a certain relief of pressure, there are small subordinate intruded masses of igneous material of lenticular character and somewhat cusp-shaped cross section. These relations are shown in fig. 3 from a careful outline drawing made on the spot, and are also seen in the photograph, fig. 2. All of these details are as clearly seen on the great cliff wall of the valley as in the diagrammatic section, the contrast of the black intruded rock masses with the light-colored sandstones being of the most pronounced kind. It is noticeable to see how the beds have adjusted themselves to the upward bend without much breaking or rupturing.

At the other end the relations are less clear, the valley wall has been broken down and eroded somewhat so that there is not the same vertical cut, but the exposures are quite sufficient to show that the structure is less typical, the beds having yielded to some extent by rupturing. The laccolith, however, frays out in thin, fringing sheets, and the basal sheet, to which it thins down, has the same thickness and character as on the other side and may be traced, always at the same level horizon, among the sandstones several miles up the valley. The persistency of these basal sheets or indeed, more correctly, of the one thin sheet of which the laccolith is itself a greatly thickened portion, is quite remarkable.

The Laccolith Rock.—The rock composing the outer fringing sheets is dark colored of dense texture spotted with crystals of a black augite and round white spots of an altered leucite; it may be called a leucite basalt. The lower 12 to 15 feet of the great columns of the main body of the laccolith are also composed of this rock, which then passes into a fully granular one of granitic texture consisting of augite, olivine, biotite and orthoclase, the shonkinite described in our paper on Square Butte previously referred to. At the top the columns pass into the porphyritic leucite basalt again, and as this contact modification has a somewhat different color from the dark shonkinite, each of the vast columns, at a distance, has a quite distinct capital and base of a different color from the main body of the shaft.

Interior of the Laccolith.

It has been mentioned that the central portion of the laccolith wall has been broken by an intersecting stream gorge which has cut down through it and into the underlying sandstones upon which the laccolith rests. A small stream of clear water issues out of the gorge and nourishes some vegetation in its bottom, whose greenness is in grateful contrast to the somber rock masses rising on all sides and to the arid valley of Flat Creek. At the very entrance to the gorge and picturesquely shaded by a grove of tall cottonwood trees stand the buildings of the Wilson ranch looking down the slope into the Flat Creek valley or Shonkin Sag, as seen in fig. 4. Following up the stream, its bottom gradually rises above the sandstones until it is in the igneous rock and at the same time it branches out into tributary gulches, so that in this way the whole interior of the laccolith is thoroughly dissected and laid bare for inspection and study.

In the rising floor of the gulch, one soon comes to the contact of the igneous rock and the sandstones on which it rests,

and there is here afforded a good opportunity to observe the effect of the contact metamorphism. The fissile, platy sandstones at the contact, are changed to a dense, flinty rock of a blue color, which is generally but a few inches in thickness and the total effect about a foot; in places, however, the change to the blue rock, the maximum effect, may be as much as two feet. Thus the actual amount of metamorphism produced in the sediments is very limited. The igneous rock at the con-



FIG. 4. Mouth of dissecting gulch. Shonkinite resting on sandstones on the right.

tact is very dense and dark, filled with augite and altered leucite phenocrysts; it is similar to that described in the outer columns above. It maintains this character for a height of about fifteen feet and then passes into an evenly granular, coarse-grained shonkinite. This has a columnar parting which, as one approaches nearer the center, is less evident than in the outer cliff wall. The branching drainages now lose their perpendicular canyon-like character and widen out into V forms with broader spurs between them, in places grassed over but often showing wide expanses of naked rock. In other places they are covered with heapings of morainal drift whose rounded pebbles are composed in part of what appears to be rocks of Bearpaw types and in part of Canadian. It is thus not local but general in character, and thus possesses a peculiar significance, which will be adverted to again in another place. It is the most southern point reached by the drift in this place, and marks the limit in this direction of the terminal moraine.

Always ascending, the shonkinite is found to have a thickness of about seventy-five feet, when it suddenly passes into a rock of quite different character. So far as the exposures show there does not appear to be any contact between the two, but the shonkinite quite suddenly, in a little distance, passes into the new type. This is a much lighter colored rock of a coarser grain, so coarse, in fact, as to have quite a pegmatitic appearance. It is composed of large augites, many of them one to two inches long, often radiating from a common center in such a manner as to form stars, and equally long but slender foils of biotite, filled in between with white feldspars or feldspathic material. This rock was always found in so weathered and crumbled a condition that no good fresh specimens of it could be obtained. In thickness, this layer or zone is about fifteen feet and it passes above into a white syenite of medium grain, specked with augite crystals. This has a rather thin, horizontal, platy parting, by which it splits and weathers into piles of plates. Seen in the bright light of a clear, sunny day, the contrast with the dark shonkinite makes the one seem white, the other black, especially when they are seen in large masses. In hand specimens, the contrast, though very strong, is not so pronounced.



FIG. 5. Erosion monoliths in interior of laccolith.

This syenite resists weathering much better than the crumbly, transition rock mentioned above and has, therefore, conditioned the formation of curious and fantastic rock piles along the line of the outcrop. They commonly take the form of a mushroom or stool in which the outspreading top is formed of the syenite, while the stem is composed of the transition rock. They are illustrated in fig. 5 from a field sketch. These are often fifteen feet or so in height and their mode of formation is much like that of rock tables standing on an ice foot on the surface of a glacier or the breccia hoodoos of the Yellowstone Park. They are somewhat different and smaller than the monoliths of the hoodoo zone around the base of Square Butte, which have been formed in a somewhat similar way. Seen in rows along the hillslopes at the outcrop of the transition rock, they present a weird and curious effect, suggesting crude architectural efforts of some primitive race. In other places the transition rock weathers back along the outcrop into shallow caves, the floor of shonkinite, the roof of syenite, the entrance

marked by thick pillars of the transition rock. This is merely an earlier stage of the development of the isolated mushroom-like masses, and one phase of it is shown in fig. 6.

The thickness of the platy white syenite is about 25 to 30 feet and above, always ascending, it passes in narrow limits into the same coarse, crumbly, transition rock as that below it. Here on top, however, this is but about five feet in thickness and it then passes into a coarse shonkinite like that below; this in about five feet begins to be denser and blacker, and in about five feet more it becomes a porphyritic rock spotted with augites and altered leucites, the same leucite basalt as at the very bottom.

We are now on the very top of the laccolith; an elevated plateau devoid of vegetation save for a sparse growth of grass. On all sides, except on the cliff looking down into the Shonkin Sag, it rolls gently down towards the sediments showing a marked turtle-back form and its center is cut into by the descending gulches which merge into the dissecting gorge. Except around this basin it is covered with the overlying sediments, but here the top of the igneous rock is exposed. In one place the cover was found to be cracked and filled with a dike of much altered basic rock.

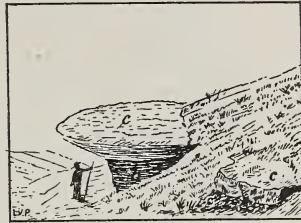

FIG. 6. Early stage of erosion monolith.

Cause of the Dissection.

In the foregoing description there has been given somewhat fully the actual facts to be observed in the field, and there now remains the interpretation of them. From what is stated elsewhere in the chapter on the Shonkin Sag and from the presence and character of the morainal drift, it is evident that during the glacial period the continental ice sheet in this region pushed its way as far south as the lower slopes and foot-hills of the Highwood Mountains. In its advance the Missouri River was driven southward and forced to flow around the foot of the ice front. In doing so it excavated the valley of the Shonkin Sag and thus sawed down and through the outer circumference of the laccolith as a knife might cut down through a cake. It is possible and even probable that the river deepened and cut out an already existent smaller valley, entirely removing the outer section of the laccolith. The position of the intersecting tributary was also previously determined, and the ice moved over the already eroded surface of

the laccolith. Evidences of scouring and polishing were not observed on those parts of the laccolith surface which were crossed, but it is probable that they may exist. The dense hard basalt of the contact variety was noted as scratched and striated boulders in the drift. At the close of the glacial period the

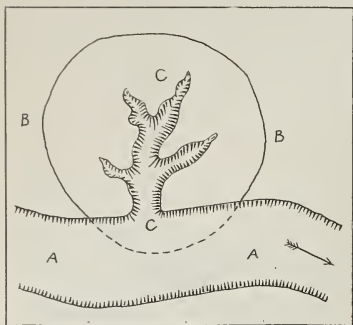

FIG. 7. AA, former Missouri valley. BB, laccolith. CC, intersecting tributary.

river retreated to its present position, and since then erosion has deepened and extended the dissection. The relative position of the former Missouri valley, the laccolith, and the dissecting stream are shown in the adjoining fig. 7, which represents them in a diagrammatic ground plan. In fig. 8 is given a stereogram of the laccolith in which the various points mentioned are shown in a diagrammatic manner the area bared by erosion.

river retreated to its present position, and since then erosion has deepened and extended the dissection. The relative position of the former Missouri valley, the laccolith, and the dissecting stream are shown in the adjoining fig. 7, which represents them in a diagrammatic ground plan. In fig. 8 is given a stereogram of the laccolith in which the various points mentioned are shown in a diagrammatic manner the area bared by erosion.

Internal Structure.

From the description which has been given, it is clear that the outer portion of the laccolith is different from the interior

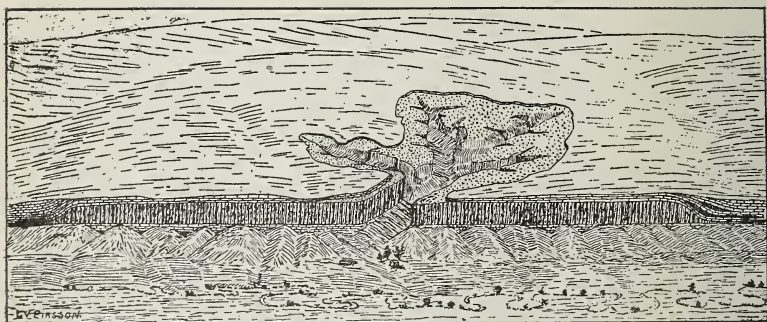

FIG. 8. Stereogram of Shonkin Sag laccolith.

in the character and types of rocks composing it. These may be concisely summed up in the following section, which may be regarded as approximately correct.

Sections of Laccolith.

	Center feet.	Outer wall feet.
Leucite basalt porphyry	5	10-15
Dense shonkinite	5	-----
Shonkinite	5-6	-----
Transition rock	3	-----
Syenite	25-30	-----
Transition rock	15	-----
Shonkinite	60-75	75
Leucite basalt porphyry	15	15
<hr/>		<hr/>
Total (approx.)	140	100

From these data we can now construct a cross section of the laccolith which will have the appearance shown in fig. 9.

FIG. 9. Cross section of Shonkin Sag laccolith.

In this figure the cross section is in its natural proportion as regards the relation of the vertical and horizontal scales, and this shows the sheet-like or flattened character of the laccolith. The transition rock and the syenite are included in the uncolored portion of the section; their vertical thickness is known, but their horizontal extension is from necessity largely conjectural, since we have the distance of its extension from the center in only one direction towards the outer cliff wall side, as revealed in the dissecting gulch.

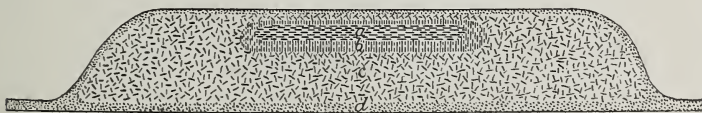

FIG. 10. a, Syenite; b, transition rock; c, shonkinite; d, leucite basalt porphyry. Vertical scale six times the horizontal.

Fig. 10 is simply an enlargement of the preceding diagram in order to exhibit better the relation of the parts. The vertical scale is six times that of the horizontal in order to bring the diagram within practical limits. This does not, of course, affect the relative ratios of thickness of the different layers to one another.

Our interpretation of the facts previously described then, is, that if one were to take the cross section of fig. 10 and revolve it upon a perpendicular drawn through the middle point, the resulting figure of revolution which would be generated would exhibit our conception of the laccolith and the structural relation of its interior parts. It is true this would cause the laccolith to become a true circle in ground plan, and the successive shells and syenite kernels to be also circular in ground plan or projection on a horizontal map surface, and to have a common center—and we do not know that this is exactly the case; the laccolith may be more or less ellipsoidal or irregular in outline and so also the interior shells and the kernels; they may not have exactly common centers nor be everywhere of the same thickness, and this is very probably the case; nevertheless, these are mere details and we believe of little importance in comparison with the idea that the figure would express the generally circular, concentrically zonal arrangement of the parts.

While the discussion of the facts presented and the conclusions drawn from them in their special relation to recent theories in the field of petrologic research would carry us too far for the purposes of this paper, it will be well to point out here some of the important bearings they have in this respect.

In the first place, it appears clear to us that the structural relations of the different parts of the laccolith to each other are due to causes which have operated in the laccolith itself. We conceive that the body of the magma forming the laccolith must have been injected as a whole, in a homogeneous condition, and that rearrangement and formation of the various parts followed within the mass itself. The occurrence of ball-like masses in the upper crust of the laccolith seems to show that the filling took place with considerable rapidity. We believe that after injection of the homogeneous magma, the first stages of cooling and crystallization against the outer envelope of sedimentary rocks was relatively more rapid than that affecting the inner portion, and resulted in producing the outer porphyritic shell, the zone of endomorphic contact metamorphism. In the meantime, and as time went on, there was a gradual withdrawal and concentration of lighter feldspathic material by some process of differentiation, to the inner upper portion of the mass, with a relative enrichment of an outer zone in lime, iron, and magnesia. This is most marked in the case of the white, inner syenite, and naturally less so in the transition rock.

After the process had finished or perhaps while it was still going on, crystallization and solidification were advancing from

without inwardly, and finally the laccolith was formed as we now find it.

On the other hand, we do not believe that the laccolith was produced by successive injections of magmas of different chemical composition which were injected into those already injected and solidified, splitting them in the process. The significant, orderly and regular arrangement of the different parts in concentric zones, the lack of contact phenomena between them, their gradation into one another from the most basic on the outside to the most acid on the inside, and the chemical relationships of the different types all seem to us to clearly forbid such a supposition, to say nothing of the mechanical difficulties involved. And also the recurrence elsewhere in this district of the same rock types with similar arrangement as at Square Butte, has a positive bearing on this point and is another strong, if not conclusive argument against such a theory.

It also appears to us that the theory, where acid, feldspathic, intrusive masses are formed with basic border zones rich in lime, iron, and magnesia, that this is due to absorption of such material by the fluid magma from the surrounding rocks is not applicable in this case, however, it may be elsewhere. The reasons for this may be divided into three heads.

First. From the regular and orderly arrangement of the parts, it is evident that such absorption could not have taken place at lower horizons with subsequent injection of the homogeneous magma into its present position. If melting and absorption of the sediments took place, it did so in the place where the mass now is. But in this case it is clear that the magma must have had the composition of the inner, highly alkaline syenite. An inspection of the section drawn on the natural scale will at once show that, to produce the great body of shonkinite from the syenite, there must have been melted up and absorbed a vast body of surrounding rock, an effect inconceivably too great for any body of injected molten magma to perform. And in this case how should we explain the thin fringing sheets, homogeneous throughout, having nearly the same composition as the shonkinite, and which run out for such great distances among the unchanged sandstones.

Second. The theory demands that lime, iron, and magnesia should be the elements absorbed, but the laccolith lies surrounded by Cretaceous sandstones, composed chiefly of quartz with some feldspar. Indeed, in the sedimentary formations of this portion of Montana described by us in numerous memoirs,* we know of no series of beds which, melted up,

* Geology of the Castle Mountains Mining District, Bull. 139, U. S. Geol. Surv.; Geology of the Judith Mountains, 18th Ann. Rep., U. S. Geol. Surv., Part III, p. 437; Geology of the Little Belt Mountains, 20th Ann. Rep., U. S. Geol. Survey, Part III, p. 257.

would produce the desired result; we should have to imagine selective melting and absorption, a quite incredible idea.

Moreover this is shown by a consideration of the chemical character of the two main types of igneous rocks. An analysis of the shonkinite has been made for us by Dr. W. F. Hillebrand in the laboratory of the U. S. Geological Survey and is given below under No. 1. Dr. Hillebrand has also made a partial analysis of the syenite, the character of the material not warranting more extended work, and this is given under No. 2.

Analyses.

	I.	II.
SiO ₂	47·88	50·00
Al ₂ O ₃	12·10	19·36 (+TiO ₂ +P ₂ O ₅)
Fe ₂ O ₃	3·53	3·87
FeO	4·80	2·67
MgO	8·64	2·18
CaO	9·35	4·96
Na ₂ O	2·94	3·63
K ₂ O	5·61	8·52
H ₂ O+110°	1·52	3·53 (Ign.)
H ₂ O-110°	·70	·46
CO ₂	·12	---
TiO ₂	·77	with Al ₂ O ₃
ZrO ₂	·03	---
P ₂ O ₅	1·11	with Al ₂ O ₃
V ₂ O ₅	·04	---
SO ₃	none	---
Cl	tr.	---
F	·05	---
S	·025	---
Cr ₂ O ₃	·035	---
NiO	tr.	---
MnO	·15	---
BaO	·46	---
SrO	·13	---
Li ₂ O	none	---
	99·99	99·18

The analysis of the syenite shows 12 per cent of alkalis and in order to change this to the composition of the shonkinite an enormous amount of material would have to be added. The same may be said with regard to the alumina. It will be noticed, however, that the silica remains practically the same. The argument is the same as that which we have already adduced for Castle Mountain* and at Yogo Peak in the Little Belt Mts.†

* Bull. U. S. Geological Survey, No. 139, 1896, p. 133.

† 20th Ann. Rep. U. S. Geol. Surv., 1900, Part 3, p. 577.

Third. There is not the slightest evidence of melting and absorption of the beds in place, in fact, as we have previously described, the amount of contact metamorphism is extremely limited. Moreover, an inspection of the cliff wall fronting the Shonkin Sag, shows that the beds on top of the laccolith are the same as those which elsewhere rest on its basal beds: they have simply been lifted by the intrusion of igneous material and there is nothing lacking in the sedimentary series, a fact which at once disproves the idea of melting and absorption.

We may thus with the utmost confidence dismiss these two hypotheses, that the arrangement of the rock types is due either to successive injections or to the absorption of sedimentary material by a molten fluid and return to our original proposition, that it has been produced by processes which have taken place within the laccolith itself after it had been injected as a homogenous body of magma.

What these processes may have been will be discussed later in a work on the petrology of the region, but in concluding this description of the geology of the Shonkin Sag laccolith we desire to again remark, that we believe it furnishes one of the best and most conclusive examples of the differentiation of igneous rocks which has yet been described, and we regret that it is not in a more accessible locality for study by other geologists.

Palisade Butte.

By reference to the map, fig. 1, accompanying this paper, it will be seen that Palisade Butte is situated somewhat less than a couple of miles west of Square Butte. It stands isolated upon the open, slightly rolling plains country, and though somewhat dwarfed by the nearness of its greater companion to the east, it forms, like Square Butte, a prominent landmark for long distances across the open prairies. It rises some eight hundred feet above the plain and its outline seen against the sky resembles the weathered stump of some gigantic colossal tree.

On closer inspection its salient features are easily seen. On all sides a long talus slope in great part covered with soil and grass but broken here and there by low outcrops and masses of rock leads up with increasing gradient from the plain to the bare, tall cliffs of naked, massive rock which compose the main mass of the butte. Above these cliffs there are again steep slopes interrupted anew by cliffs.

These great walls are remarkable for the very regular and beautiful columnar structure of the rock, the hexagonal columns being on an average about eighteen inches in diameter

though often greater, divided by regular crossjoints. They extend the whole height of the exposures in which they occur and thus attain a length of 100 to 150 feet in places, but it is evident that originally they must have extended through the whole of this portion of the igneous mass, as shown in the Shonkin Sag laccolith, and therefore may have been several hundred feet in length. It is, of course, by the breaking away of these columns that the vertical cliffs have been formed. At a distance on the plain the butte appears faced by a series of colossal pillars or palisades, and from this appearance it has received its name. It strongly recalls "Mateo Tepee" or the "Bear Lodge Butte" on the west side of the Black Hills.

The rock composing the columnar portion of the butte and the outcrops in the talus is of shonkinite of a somewhat firmer texture and perhaps more feldspathic character than that of Square Butte. On all exposed surfaces it weathers to a very dark color, giving the cliffs a sombre and gloomy character.

In several places the line of cliffs is cut by deep and narrow gulches descending through them, up which one can easily clamber and attain the grassy slopes and shoulders above them, and thus by continuing reach the summit. These grassy slopes are varied here and there by groves and clumps of small pines.

The butte is crowned at the top by a large mass of a light-colored rock of a platy, laminated character. This is an augite syenite much like that already described. It weathers with a much lighter color than the shonkinite on account of the preponderance of the feldspar over the augite, and the contrast between the two, while not so pronounced as at Square Butte, is still a striking one.

The mass of syenite, which has a considerable thickness, is roughly wedge-shaped in form, with a cliff of some height toward the south and a slope toward the north. On the former side, the rock with its platy, horizontal parting is clearly seen to be resting on the massive, columnar shonkinite, but towards the north the relations are less clear because in this direction it slopes down in talus masses and in fact, on this side the butte, to a great degree, loses its precipitous character and slopes sharply down toward the plain, with the broken down rock masses intermingling.

Differentiation.—In the characteristics of the rock composing it, there is to be seen the same differentiation as that found in Square Butte and the Shonkin Sag laccolith, only not so sharply expressed. In the low outcrops of rock in places which rise through the talus slopes and are furthest from the butte, the shonkinite composing them is very rich in augite and therefore dark and basic, like that of Square Butte. As

one approaches the butte there in an increase in the feldspathic components, and the rock of the columnar cliffs is perceptibly different from that of the lower outcrops. In the syenite of the platy mass on top this difference is, of course, much more marked; the rock is not so strikingly leucocratic as the syenites of Square Butte and the Shonkin Sag laccolith, but is still a syenite.

Thus the same order holds as in the other laccoliths, a basic outer and lower mass, above a more feldspathic upper, inner portion, and there has been, therefore, the same kind of differentiation as in the other laccoliths, only more gradually expressed.

Laccolithic Character.—From what has been said we infer that Palisade Butte represents the remains of a laccolith formerly of greater size. We are led to this conclusion by its position, structures, and associations.

The three laccoliths form a transitional group; the Shonkin Sag is the flattest and also the lowest and therefore the one most protected from erosion. Its top, in fact, is just beginning to emerge, and its laccolithic character would not be so evident if it were not for the trenching in it by the former river action which has given such good cross sections. Square Butte stands much higher and has been exposed to much greater denudation; its cover, save in small areas around the base, has been stripped off and a considerable part of the igneous rock removed. Palisade Butte, standing at the same level as Square Butte, has suffered from the same amount of erosive agencies, but being smaller in size the relative effect has been greater and the cover has entirely disappeared, and a large part of the laccolith, so that around it the floor is exposed and only the central portion of the mass remains.

U. S. Geological Survey, Washington, D. C., and Yale University,
New Haven, Conn., April, 1901.

ART. II.—*On the Manganese Ore Deposits of the Queluz (Lafayette) District, Minas Geraes, Brazil*; by ORVILLE A. DERBY.

IN a communication entitled "The Manganese Ores of Brazil," published in the Journal of the Iron and Steel Institute for the current year (1900), Mr. Herbert K. Scott gives a very interesting account of two ore districts in the state of Minas Geraes that within the last few years have sprung into considerable prominence on account of the abundance and high quality of their ores. These two districts, though adjacent, differ widely in geological characters and in the mode of origin of their ores. The Miguel Burnier-Ouro Preto district, which is more particularly described by Mr. Scott, is constituted by a series of quartzites and schists in which hematitic quartzschists (itabirites) are a prominent feature, the manganese ore occurring in intimate association with these iron schists and with limestone. The geological conditions are therefore similar to those described by Vogt in his work *Salten og Ranen* for certain Norwegian deposits of associated iron and manganese ores that have almost certainly been derived through leaching from iron- and manganese-bearing carbonates. The details given by Mr. Scott are very conclusive in support of this view of the mode of origin, which I have briefly discussed in a note appended to his paper.

In the closely adjacent Queluz* district, on the contrary, the ore bodies occur in association with granitic and gneissic rocks and there is a complete absence of the calcareous and ferruginous beds that accompany the ore in the other district. The mining and prospecting operations thus far effected have, on account of questions of transportation, been limited to a zone 10 to 20 kilometers wide on each side of the railroad. In the zone thus defined the outcrops of ore are so numerous and large as to indicate an extremely extensive and widespread mineralization of an area that is doubtless much larger than has thus far been recognized. The existing maps of the region are so defective that no positive correlation of the different outcrops can be made, but there are strong indications of the existence of at least three distinct ore belts. These are:

1st. A western belt, marked by the two active mines of

*The name Lafayette given in Mr. Scott's paper was given to the railway station in the border of the town of Queluz in order to avoid confusion with another place of the same name in the same railway system. In common parlance the name Lafayette has come into general use for the whole district, but in the administrative division of the state Queluz is still retained as the name of the town and of the municipal district of which it is the center.

Piquiry and São Gonçalo, situated some 3 or 4 kilometers apart on the same ridge, with a number of known intermediate outcrops and probably prolonged southward by others that have been prospected but not worked,

2d. An eastern belt, marked at the extremes, so far as known, by the Morro da Mina (Mine Hill) and Agua Limpa (Clear Water) deposits; and

3d. A central belt, represented by the abandoned Barroso workings close to the railroad a few kilometers south of the town.

At all of the localities above mentioned perfectly sound granite occurs within a few hundred meters of the ore bodies and at Piquiry the wall or walls are constituted by a residual clay resulting from the complete decomposition *in situ* of a typical granitic rock that gives an abundant and characteristic residue of sharp-edged zircons. At São Gonçalo, where only the foot wall is exposed to view, this and some intercalated layers near it are of completely decomposed schists whose original character will be discussed farther on. At Barroso both foot and hanging wall are of decomposed schists that are suspected to have been originally amphibolic, while at Agua Limpa a sound amphibolic schist of peculiar character occurs within a few meters of the ore body. At Morro da Mina, aside from dubious decomposed schists apparently similar to those at São Gonçalo, a peculiar residual clay occurs that will be discussed below. A peculiar feature is the occurrence of well-defined layers of graphitic schist in the ore of Agua Limpa, Morro da Mina and São Gonçalo, while at all of the localities parts of the ore body are more or less graphitic.

The Piquiry ore body presents the appearance of a mass of secondary material, or gossan, resulting from the alteration of a vertical dike or vein, some ten or dozen meters wide. The margins are sharply cut against a tough clay which is undoubtedly decomposed granite, presumably identical with the sound granite occurring a few hundred meters distant from the mine. In appearance both foot and hanging wall are presented, but Mr. Scott thinks that the opening is on an elbow of the ore body, so that in reality only one wall is seen. The ore is a hard spongy black oxide apparently consisting for the most part of psilomelane but with an admixture of other oxides that frequently occur in beautiful crystallizations in the spongy cavities. No cargo analyses are at hand, but Mr. Scott gives for a sample of ore prepared for shipment: manganese (metallic) 51.40 per cent, iron 2.00 per cent, siliceous residue 5.02 per cent, phosphorus 0.13 per cent.

In the midst of the merchantable ore occur inconstant bands and patches of hard siliceous material with the appearance of a

quartzite, but which on examination proves to be composed almost exclusively of a finely granular mass of ashy white manganese garnet. A complete series of alteration phases between perfectly typical garnet rock and merchantable ore can be readily selected, and there can be no doubt that the latter results from the decay and leaching of the former.

In part from the ore body itself, in part from the dump heap of rejected material, the following phases of the garnet rock were obtained.

1st. A very fine-grained, compact and finely jointed rock of bluish gray color with partings lined with asbestos. Under the microscope the rock is seen to be composed almost exclusively of closely appressed idiomorphic grains of white garnet showing a clear border but with the center highly charged with a fine black opaque powder that appears to be graphite. In the somewhat rare interspaces between the garnet grains and molded upon them is a glassy white anisotropic mineral generally altered to a mass of asbestiform fibers which, so far as its form, optical properties and cleavages can be made out, is a member of the amphibole group. A qualitative test on a small amount of material, largely asbestiform, separated with heavy liquids shows the presence of silica, lime, magnesia, iron, manganese and alumina, the latter in scarcely more than traces, thus confirming the identification of the mineral as an alumina-free amphibole. The only accessories that could be detected in the section are apatite in rare grains and the above mentioned inclusions in the garnet, the reference of which to graphite is apparently confirmed by a distinct reaction for carbonic acid after fusion with nitre and by the presence of free graphite in other similar rocks from the same ore body. An analysis of this rock kindly made by Dr. G. Florence gave:

SiO ₂	38.47
Al ₂ O ₃	21.07
Fe ₂ O ₃	7.38
MnO	27.90
CaO	4.70
	99.52

A second specimen of the same general type but not jointed is largely oxidized and stained at the margins and in patches with manganese oxide and has the amphibolic mineral stained brown while the apatite is much more abundant.

2d. A dark brown rock heavily charged with manganese oxide and too friable to permit the preparation of microscopic sections is evidently of the same type as the second specimen above mentioned but more completely decomposed and much

more heavily charged with graphite. The very abundant residue obtained by washing, or by treatment with acid, is in great part of a dirty white color, the garnet grains being discolored by a closely adherent graphitic powder. The amphibolic mineral, apparently more abundant than in No. I, appears in the residues in rudely prismatic forms but is too heavily stained with manganese oxide to permit of a satisfactory determination. No apatite could be detected in the residue, but the acid solution from the rock gave a distinct reaction for phosphoric acid.

3d. A milky white rock which under the microscope is seen to be composed of about equal parts of garnet and quartz, the latter being abundantly threaded with delicate transparent needles of a white asbestiform mineral. The garnet is for the most part larger and better crystallized than in the specimen above described and has a decided yellow tinge. The quartz in a fine mosaic about the garnet grains and in minute refilled joints is almost certainly secondary, filling the place of some mineral that has disappeared. The asbestos (?) needles, in part free, in part included in the quartz, are undoubtedly secondary but not, as in the case above described, formed without migration by the transformation in place of some preëxisting mineral. The only accessory, embedded in the garnet as well as in the quartz and thus probably of primary origin, is a transparent red mineral in minute grains and hexagonal flakes that give strong reactions for both titanium and manganese. The crystallographical, optical and chemical characters of this mineral, so far as they can be made out, agree with those of pyrophanite.

The above observations indicate that the original rock from which this ore body was derived was essentially a manganese garnet rock containing sporadically (and perhaps in segregated masses) an amphibole mineral, apatite, a titanium mineral and presumably an easily decomposable silicate that has entirely disappeared. Graphite is also distributed capriciously throughout the mass, but, as will be shown below, this is perhaps not an original or essential element. The predominant quantity of merchantable ore of high grade shows that by far the greater part of the mass must have been an almost absolutely pure manganese garnet rock from which silica and alumina have been leached out. Since in the process of oxidation iron oxide would almost certainly have remained and have been concentrated with that of manganese, the original rock (and especially the garnet) must have been notably free from this element, which in the ore analyses is in smaller proportions than in the rock sample above analyzed. It is worthy of note that no free iron

oxide, in the form of magnetite, ilmenite or hematite, could be detected as an original element in the sections or residues.

At São Gonçalo the main ore body, composed exclusively of hard secondary material similar in appearance and composition to that of Piquiry, has the appearance of a heavy intercalated bed with an inclination of 30–40° in a decomposed schistose rock. Sound granite occurs a few hundred meters away, but none was seen in immediate contact with the ore. The principal working near the top of a high hill exposes about three meters of the foot wall, consisting of banded clay of predominant red color with white streaks, which on a carefully scraped surface shows a characteristic gneissic structure with indications of small included fragments, or segregations, differing somewhat in texture and color from the body of the rock. On washing, this clay gives a very abundant argillaceous slime, leaving a residue of tolerably abundant white mica (bleached biotite?) with a very moderate amount of quartz and in the heavy portion rare grains of transparent red (secondary?) hematite and tourmaline. Next to the ore body the clay for the space of about 20 centimeters is lighter colored with white and yellow streaks, and this shows very distinctly an augen-gneiss structure. Its residue does not differ materially from that of the underlying reddish clay except that the micaceous portion has more the appearance of secondary sericite.

From the above observations it is tolerably evident that the foot wall at São Gonçalo was a somewhat micaceous gneiss poor in quartz and without characteristic elastic or granitic accessories, that is to say, it was most probably a sheared basic eruptive presumably of dioritic or gabbroitic type.

At the base of the ore body comes a layer about 30 centimeters thick of quartz rock charged with manganese oxide and with the appearance of shattered vein quartz. This gives a moderate residue of garnet without other recognizable accessories.

Above the quartzose layer and separating it from the heavy mass of secondary oxide that constitutes the ore body proper, comes a layer about 40 centimeters thick of a banded yellowish clay with tolerably distinct traces of original feldspathic and micaceous elements giving a well-defined gneissic structure. This gives on sliming a residue of secondary (?) mica and earthy grains of manganese oxide.

Higher up in the ore body is another clay layer from 2 to 3 meters thick which on a scraped surface shows a granitoid aspect, with small scattered patches of earthy manganese and iron oxides that appear to occupy the place of some original manganese-bearing bisilicate element. This also gives a very abundant argillaceous slime with a residue of granular kaolin,

secondary (?) mica and, aside from the earthy oxides, a few rare grains of tolerably large and well-formed zircons. This clay body apparently represents an unsheared eruptive rock, possibly of gabbroitic type.

Still another clay horse some 2 meters thick is gneissic in structure with white kaolinitic and greenish and yellowish micaceous (?) elements and nodular masses of clay charged with manganese and iron oxides. The residue after sliming consists of secondary (?) mica without quartz, and heavy dirty white earthy grains with occasional inclusions of rutile that are almost certainly alteration products of ilmenite. Associated with this layer is a thin one, a few centimeters thick, of a pulverulent clay heavily charged with graphite.

With the exception of the above mentioned quartzose layer (or sahlband), which apparently must be considered as an integral part of the ore body and which by its quartz and garnet contents establishes a relation with the original type of the Piquiry ore mass, the mineral at São Gonçalo is so completely altered by secondary processes as to give no clue regarding its original character and origin. The included horses of clayey matter may, *a priori*, be either inclusions of country rock, segregated masses of the original rock of the ore body itself, or intrusive dikes. The hypothesis may be ventured that the gneissoid layer without manganese and with traces of original ilmenite is of the first character, that the gneissoid layer above the quartzose one and with traces of manganese oxide is of the second, while the granitoid body with traces of manganese oxide and with zircon may be a mass of the same character that has escaped shearing, though it is more probably an intrusive dike.

The ore of the main opening is almost exclusively a hard stony, spongy psilomelane like that of Piquiry but presenting more distinct evidences of shear structure. A prospecting analysis by Mr. Scott gave metallic manganese 49.10 per cent, siliceous residue 6.34 per cent, and phosphorus 0.126 per cent. Lower down on the hillside another opening has been made which affords in part a hard secondary ore of the same character as the above, in part an ore of earthy aspect that was at first considered to be of doubtful character but which on analysis proves to be good merchantable stuff. This evidently represents an altered schistose (sheared) manganese-bearing rock in which the resulting oxide has not, to any considerable extent, migrated or been recrystallized but has apparently become somewhat hydrated, since a rough test gives about 6 per cent of water. Its appearance is that of a decomposed argillaceous or calcareous schist profusely pitted with minute rounded cavities that are frequently lined with a fine white crust of secondary silica that, on dissolving the oxide, present the appearance

of pseudomorphs of microscopic garnets. Another locality, to be discussed below, proves that this interpretation is correct and that the pitting of the rock is due to the disappearance of included garnets. Other specimens from the same opening, in which the structure above described is obscured by secondary manganese oxide, give a residue with some sound garnet, with a minute quantity of ilmenite and, on ignition with nitre, a tolerably abundant reaction for graphite.

The Morro da Mina, situated some 6 to 8 kilometers to the northeastward of the town, is a high hill covered quite uniformly with outcropping, or loose, ore and thus presenting the most extensive ore deposit yet known in the district. As, however, this ore is more siliceous than the present high requirements of the market admits, very little has been done in the way of development except in the loose superficial material that gives little insight into the structure of the ore body, but fortunately an old abandoned mining tunnel, apparently driven by some deluded gold prospector, gives a good section of a considerable portion of the mass and below the zone of surface action. As at Piquiry and São Gonçalo, granite occurs in the immediate vicinity of the hill but none was seen in close contact with the ore body. Prospecting operations in the neighborhood show that the ore continues for a considerable distance both northward and southward from the hill, and there are strong indications that in the latter direction a more or less continuous line of outcrops connect this locality with that of Agua Limpa, some ten or dozen kilometers distant.

The above mentioned mining tunnel, which unfortunately could only be examined by the insufficient lighting of matches, extends for about 25 meters in very hard somewhat sheared manganese ore and terminates in soft unshaped clay that evidently represents some massive rock decomposed *in situ*. An assay sample taken by an experienced prospector at every two meters shows that the mass is tolerably uniform in structure and composition and that, except in comparatively insignificant patches, the rock is perfectly fresh. This sample is understood to have given on analysis about 40 per cent of metallic manganese, thus corresponding very closely with the analysis given below of a picked specimen, if, as is presumable, the metallic contents was only determined in the soluble portion, the abundant residue being set down as quartz without further examination. This ore body has the appearance of a vertically sheared dike, or intercalated bed of which one side is free, forming the steep slope of the hill, while on the other side comes the above mentioned clay mass that separates it from another smaller and parallel ore body that outcrops on the top of the hill at a distance of some dozens of meters.

In the specimens obtained from this tunnel the altered patches present the earthy pitted appearance of the above described ore from São Gonçalo and like that give, on treatment with acid, a residue of microscopic garnet, skeletons of secondary silica in the form of garnet and a moderate amount of exceedingly fine black sand giving a strong titanium reaction and that is apparently ilmenite with a slight admixture of transparent red grains without defined form that appear to be rutile. The perfectly sound rock has a hardness between 6 and 7 and a steely luster, but under the lens is seen to be minutely mottled with white points corresponding to the pitting of the decomposed portions. Occasional patches of oriented sheen appear to be cleavage surfaces of large prismatic crystals. Treated with hydrochloric acid, even in considerable lumps, the black portion of the rock is readily and completely dissolved, leaving a considerable residue of white garnet with a slight amount of flocculent silica, ilmenite and rutile (?). Under the microscope the rock is seen to consist of minute isolated grains of garnet embedded in a much more abundant groundmass of manganese oxide of uniform steely luster, except in a narrow zone around each garnet grain where it is coal black and apparently softer. This black zone apparently comes from a beginning of alteration in the garnet, though it may also be due to an incipient hydration of the manganese oxide of the groundmass. In any case, the rock is essentially a mixture of a hard prismatic, cleavable manganese oxide with a manganese garnet, both being primary elements. An analysis kindly made by Dr. Florence gave :

Residue insoluble in hydrochloric acid	20.78
SiO ₂	0.77
Fe ₂ O ₃	5.79
NiO + CoO	0.30
MnO	8.54
MnO ₂	57.38
P ₂ O ₅	0.08
CaO	0.49
MgO	0.20
H ₂ O	3.91
	98.24

The deficiency in this analysis is perhaps due in part to the presence of alkalis that were not determined. The manganese oxides calculated as metal and oxygen and reduced to 100 give: Mn. 65.06 per cent, O 34.94 per cent, which corresponds quite closely with the composition of polianite (Mn. 61.1 per cent, O 36.9 per cent), and in view of the physical properties,

so far as they can be made out, it is probable that the rock consists essentially of polianite and spessartine with small amounts of some lime and magnesia silicates, apatite and possibly ilmenite, though a portion of the water is doubtless combined with the manganese, which is in part visibly altered, and the iron may also be, in part, combined with the manganese oxide. The presence of a small proportion of nickel and cobalt is an interesting feature.

The clay in which the tunnel terminates shows no structural features except scattered patches of soft earthy manganese and iron oxides suggestive of segregations of original bisilicates in an essentially feldspathic rock. The slime obtained by washing consists largely of minute micaceous flakes, and the residue of a small amount of minute quartz grains with heavier dirty white earthy grains that give a titanium reaction and are probably leucoxene representing original ilmenite. A specimen taken close to the contact with the ore gives also a small amount of well-formed brown tourmalines, but this does not appear to be generally distributed throughout the clay mass. From the above characteristics it seems almost certain that this clay represents the decomposition product of an original massive eruptive rock that was predominantly feldspathic but with segregations of a manganese-bearing bisilicate element and with ilmenite as the only accessory. If, as seems most plausible, the small residue of quartz be regarded as secondary, the original rock was probably a gabbro or some closely related type.

At the point of the hill and apparently in prolongation of the smaller dike-like outcrop above mentioned as occurring at the top, mining operations had been commenced, in part in loose secondary ore, in part in ore *in situ*. The latter has an impure earthy appearance like that above described from São Gonçalo and such as might be expected to result from the alteration of the hard garnetiferous ore of the tunnel and of the said dike-like ore body. The siliceous residue is understood to run from 16 to 20 per cent and the contents in metallic manganese from 37 per cent to 45 per cent. A small pit showed two ore bodies of this type *in situ*, each being about three meters thick, and separated by a foliated layer of granular quartz rock about one meter thick. This quartzose layer resembles closely the itacolomite of the Ouro Preto region, but, unlike it, is without mica and gives no elastic residue, the only heavy element being transparent hematite that evidently comes from altered pyrite. Underneath the lower ore body comes laminated clays, in part graphitic, that are evidently derived from decomposed schists but are too incoherent to show distinctly the original structure. These give on sliming a residue of coarse quartz with nodules of earthy iron and manganese oxides

and a small amount of ilmenite, tourmaline and rutile, all of which have the appearance of autigenetic elements.

In the dump a few blocks of harder rock of various types were found which from their rarity and evident sporadic mode of occurrence may be presumed to represent segregated masses in the midst of the predominant type of earthy ore. One of these is a quartz-garnet rock like that already described from Piquiry but without traces of a bisilicate element and with the quartz mosaic in comparatively large grains that suggest a doubt as to whether this mineral is a secondary or primary element. Another highly quartzose type has as a bisilicate element an altered mica and has, as an accessory, yellowish isotropic grains that could not be determined but that give a decided titanium reaction. Still another type is a garnet-amphibole rock with rare grains of secondary (?) quartz and with the garnet full of delicate rod-like inclusions that appear to be acicular amphibole. With the exception of the mica-bearing rock all of these types are identical with those found at Piquiry, though no case of the formation of the secondary asbestos was observed.

At the Agua Limpa locality prospecting operations have revealed an extensive ore body which at the surface is composed mainly of secondary oxide but with a sufficient admixture of garnet to show that this body is also essentially a mass of garnet-bearing rock. A small pit shows underneath the ore a layer of about 20 centimeters thickness of graphitic earth with patches and streaks of white clay and resting on a mass of yellow clay enclosing graphitic patches. The graphitic earth gives much ilmenite but no other recognizable heavy residue, while the white streaks and patches in it give much quartz with a heavy residue of magnetite and malacolized zircon indicating that they probably represent apophyses of the neighboring granite. The yellow clay is massive with small patches of earthy iron and manganese oxides, thus resembling closely, except in color, the clay of the tunnel at Morro da Mina and like that giving a residue of fine quartz with ilmenite partially altered to leucoxene.

In the bed of a small stream a few meters from this pit is an outcrop of perfectly sound amphibole schist consisting principally of two types of amphibole (actinolite and cummingtonite ?) in a fine mosaic of quartz and feldspar with sphene and a garnet giving a manganese reaction as tolerably abundant accessories. The heavy residue shows a small amount of ilmenite and amongst the smaller garnets yellowish crystals of ideal perfection of form. This rock has every appearance of a recrystallized sheared eruptive, and if so was probably originally of dioritic or gabbroitic type but containing manganese garnet

or, perhaps more probably, a manganese-bearing silicate that has given rise to the garnet in the process of metamorphism. Such a type, if unsheared and decomposed, would give rise to a clay very like that found in the immediate vicinity in the above mentioned pit, and the hypothesis may be ventured that the two represent sheared and unsheared portions of the same rock mass.

On the opposite side of the hill and a few scores of meters to one side of the ore belt pits had been opened in partially decomposed granite with stringers from a few millimeters up to about a meter in width of graphite, which though somewhat mixed with clayey matter appears to be of good quality.

At the Barroso locality, which, as already remarked, appears to mark a third ore belt intermediate between that of Piquiry-São Gonçalo on one side and that of Morro da Mina-Agua Limpá on the other, two openings have been made several hundred meters apart and apparently on independent ore bodies. One exposes a layer about two meters thick and with an inclination of about 45° between walls of decomposed schist threaded with stringers of granite. The ore presents for the most part the aspect of the earthy material at São Gonçalo and like that gives a residue of microscopic garnet but with a greater amount of quartz and of clayey matter. In places it passes to a granular quartz rock thickly sprinkled with macroscopic garnets. The enclosing schist presents an appearance suggestive of an original amphibolite and gives a residue of ilmenite only, and apparently represents a sheared eruptive of non-granitic character. In the other and more important opening the ore body is 4 to 6 meters thick, inclined at an angle of about 80° between walls of decomposed schist without granite. The ore, which is of the same general character as that of the first opening, though of better appearance is quite impure, giving, according to Mr. Scott's analysis of an average sample, 28.10 per cent of metallic manganese, 6.00 per cent of iron, 15.80 per cent of siliceous residue and 7.20 per cent of graphite. Much of the ore has the aspect of a decomposed graphitic clay slate charged with secondary manganese oxide, but one of my samples, too friable for a microscopic preparation, resembles, both in aspect and in its residue, the garnet-quartz rock with mica from Morro da Mina and like that has no graphite. Another specimen showing considerable well-crystallized graphite with ilmenite has the garnet enclosed in an earthy siliceous matrix apparently of secondary quartz stained with iron but not with manganese (except in the portions where the garnet is also decomposed), and this appears to represent an original rock composed of garnet with some iron-bearing silicate. The decomposed schist of the walls of this ore body is still quite

resistant and differs somewhat in aspect from that of the first opening but like that gives only a residue of ilmenite and appears to have been an amphibole schist.

Some 50 to 60 kilometers to the southward of Queluz and in the municipal district of Barbacena is another ore district which I have not had an opportunity of visiting but from which specimens from various points have come to hand. These represent an extension of about 30 kilometers as measured by the railroad line between the stations of Ressaquina on the north and Sitio on the south. The region, like that about Queluz, is characterized by gneissic rocks abundantly injected with granite. The ores are of two types, of which one, corresponding to that of the Queluz district, consists of a garnetiferous rock impregnated with secondary manganese oxide evidently derived from the garnet. One specimen is heavily charged with well-crystallized graphite and gives in the residue a white amphibole, neither of which minerals have been noticed in the other specimens. The second type is a manganiferous magnetite of which a specimen from near the station of Ressaquina was analyzed by Mr. Scott, who found 11.60 per cent of metallic manganese with 40.08 per cent of metallic iron. The other specimen at hand seems to be somewhat richer in manganese but is still essentially an iron-manganese ore. The appearance of this ore is that of an ordinary finely granular magnetite charged with pulverulent secondary manganese oxide. The origin of this oxide is readily found by dissolving the metallic oxide with hydrochloric acid, which leaves a more or less abundant residue of rather coarse and highly corroded spessartine often reduced by superficial etching to irregular hook-shaped fragments. The original type was therefore a magnetite-spessartine rock from which the silica and alumina of the garnet has been almost completely removed by leaching, leaving a residue of manganese oxide. From another ore district near Paranaguá in the state of Paraná a specimen of identical appearance giving about 12 per cent of metallic manganese is at hand, which appears to represent the same type from which the original garnet has entirely disappeared. This conclusion is confirmed by a specimen received later from the state of Santa Catherina, but in the prolongation of the Paraná ore district, in which, as in the Barbacena ore, a remnant of corroded spessartine is still preserved. In this costal ore district, extending from southern São Paulo to Santa Catherina and embracing the Jacupiranga deposits described by me some years ago in this Journal (April 1891), titaniferous magnetites are very abundant and characteristic, but their relations to these rarer manganese-magnetite ores are not known.

It results from the above observations that the ore bodies of the Queluz district are residual deposits derived through decomposition and leaching from an original type, or types, of rock in which manganese garnet was the most constant and characteristic silicate element. With this, which often constituted almost the entire bulk of the rock, were associated minerals of the amphibole (and perhaps pyroxene) or mica series, and in some phases free manganese oxide that when in predominant proportions gave a type corresponding to that of the free iron oxide (magnetite) and manganese garnet rock of the Barbacena district, or, in more general terms, to the well known types of magnetic or titaniferous iron oxides with various silicates. The occurrence of garnetiferous quartzites appears to indicate that in some cases quartz may also have been a primary constituent, though for the most part it seems to have been of secondary origin. As accessory elements, ilmenite and rutile are of frequent though not of constant occurrence, while apatite, though positively recognized in two specimens only, appears to have been constant since a small proportion of phosphorus has been found in all analyses in which it was looked for. A remarkable feature, considering the highly basic character above deduced for this type, is the absence, except sporadically as ilmenite, of free iron oxide and the low proportion of combined iron as shown by the analyses of the residual ores in which a concentration of this element is presumable. The Barbacena ore, however, shows that, exceptionally, free iron oxide may occur and even rise to a predominant proportion. Another remarkable feature is the tolerably constant, though sporadic, appearance of graphite, though as will be shown below this is probably an introduced element.

This type, which may appropriately be denominated *queluzite*, is more or less intimately associated at São Gonçalo, Morro da Mina and Barroso with decomposed schistose rocks that evidently contained an original manganese-bearing silicate and which from the absence of recognizable clastic elements and from other characteristics, so far as they can be made out, is presumed to have been an amphibolic schist representing a sheared basic eruptive. At Agua Limpa a confirmation of this deduction is afforded through the presence in almost immediate contact with the ore body of a feldspathic amphibole schist containing manganese garnet, which is almost certainly a sheared eruptive and, although its original character cannot be positively determined, probably of dioritic, gabbroitic or noritic character. At Morro da Mina, São Gonçalo and Agua Limpa there is also in close connection with the ore an unshered eruptive (represented by manganese-bearing clays) which in its original condition must have been of very similar

if not identical type. In the Agua Limpa schist, moreover, the manganese-bearing element is spessartine as in the ore bodies, thus giving greater plausibility to the hypothesis that the relation between these last and the above mentioned rocks may be a genetic one. If thus related, the ore bodies present strong analogies with those of magnetic, titaniferous and chromic iron ores that are now generally considered as magmatic segregations in various types of eruptive, and, all things considered, this hypothesis seems the most plausible one for the manganese ores here discussed. The fact that though carefully looked for, no rock types that could be positively, or even presumably, identified as clastic could be found near the ore bodies, makes the alternative hypothesis of a clastic origin a difficult one to apply. The occurrence of distinct traces of nickel and cobalt in the unaltered ore of the Morro da Mina tunnel may perhaps be also an argument for an eruptive origin, though too much stress cannot, without farther study, be laid upon it, since Mr. Scott reports these elements under totally different conditions near Miguel Burnier in a small patch of secondary manganese oxide that is undoubtedly a secretory deposit in a decomposed clastic schist.

Through the kindness of Dr. Francisco da Paula Oliveira, director of the geological section in the National Museum of Rio de Janeiro, I have had the opportunity of examining a specimen from a manganese ore body enclosed in granite near Queimados, in the interior of the state of Bahia, that represents another interesting phase of this rock type. The rock is perfectly fresh, showing about equal proportions of large-sized garnets and of pyroxene with a diallage-like cleavage. The garnets, which attain a size of five millimeters or more, are of a light yellow color, becoming perfectly white in thin sections, and give a strong manganese reaction. The pyroxene, when free from staining by manganese oxide, is colorless and glassy and gives an extremely abundant reaction for manganese, which is evidently much more abundant than iron. Aside from a colorless glassy amphibole intergrown with the pyroxene, no other constituents could be recognized and the rock is essentially composed of manganese-garnet and manganese-pyroxene. From such a rock through the replacement of the easily decomposable pyroxene by secondary quartz the type of quartz-garnet rock of Piquiry and Morro da Mina might be produced.* With

* This type might, however, be expected to leave some trace of its lime and magnesia in the form of secondary asbestos, and in this case the most probable representative is the quartz-garnet rock with asbestos, while the similar rock without the latter mineral may be suspected to have come from an original type in which the bisilicate element was perhaps rhodonite, a mineral that has been looked for in vain although it seems natural that it should occur in such an association of manganese-bearing rocks.

it is associated a quartz rock with large well-formed garnets but this has the aspect of vein material.

From an unknown locality in the state of Espírito Santo a specimen is also at hand showing secondary manganese oxide with garnet and well crystallized graphite. The ore that is being exported from Nazareth in the state of Bahia is, judging from a specimen received from the gentleman above mentioned, of the same type as that described from the tunnel at the Morro da Mina. The polianite (?) is coarsely crystalline and strongly predominant in quantity over the garnet, which is in great part replaced by pseudomorphic skeletons of secondary silica. This specimen contains no graphite, but I am informed that a considerable proportion of the Nazareth ore is graphitic.

The almost constant occurrence of graphite with these manganese-bearing rocks is very suggestive of a genetic relation, as is also the converse association noted by Weinschenk in the graphite deposits of Bavaria and Bohemia. It is not, however, uniformly distributed throughout the ore bodies, as might be expected if the relation was a necessary one, and, moreover it occurs also quite independent of the manganese-bearing rocks as in the granite at Agua Limpa and in a decomposed schist a kilometer or more distant from São Gonçalo. In the former case the graphite appears in both the granite and manganese-bearing rock but in greater force and purity in the former. In the latter the graphite-bearing rock has no manganese ores in the immediate vicinity and the garnets with which it is abundantly charged give no trace of that metal. This schist is also heavily charged with iron in the form of a fine hematite dust and it may be presumed to have been originally a garnet-amphibole schist, or perhaps an eclogite. This is not the place to discuss the probable origin of the graphite, but it may be remarked that the hypothesis of a gaseous introduction propounded by Weinschenk for the Bavarian and Bohemian occurrences seems to me to best meet the conditions observed in this district. Whatever may be its mode of origin and admitting a doubt as to a necessary connection between graphite and manganese-bearing rocks, it is worthy of note that the two elements carbon and manganese certainly show a predilection for each other's society.

São Paulo, Brazil.

ART. III.—*On the Bituminous Deposits situated at the South and East of Cárdenas, Cuba*; by HERBERT E. PECKHAM.

IT is a well known fact that different forms of bitumen exist upon the Island of Cuba. Mention has been made of their occurrence by several writers as long ago as the beginning of the 19th century. In 1803, Alexander von Humboldt visited the island and remained some two years, during which time he studied the geology of the country around Havana and to the eastward towards Matánzas. In 1837, we find Richard C. Taylor, the noted geologist, making an investigation of a so-called coal field at Guanabacoa, six miles east of Havana, and a short report on the same. The same author also mentions the occurrence of springs of liquid bitumen upon the shores of Havana Harbor, and also the fact that the chapapote or maltha was used by the inhabitants for pitching the bottoms of ships. These two references show that bitumen in Cuba has been observed by travelers for over one hundred years. The native population really know more than any one about the location of these outcrops, as is quickly seen when a prospector makes inquiries. While the Spanish Government held control of Cuba there was very little incentive for any one, foreigner or native, to investigate the mineral resources of the island, because of the exorbitant royalties made payable to the Crown; consequently, it is a question whether any one possesses accurate knowledge upon the extent to which bitumen occurs. However, I think enough has been done to show that there can be no doubt that valuable deposits probably exist over a very wide area.

Before the outbreak of the Spanish-American war many scientific travelers had visited the island, making observations covering a much larger area than that mentioned by the earlier writers. From the reports of these travelers, especially Americans and Englishmen, we notice that, so far, the greater number of these occurrences have been observed in Matánzas and Santa Clara provinces. These are so situated geographically that we find solid bitumen extending along the northern coast from Havana eastward as far as Cárdenas. Inland to the south of Cárdenas and eastward the bitumen is more fluid until at Motembo we find a well producing colorless naphtha; while still farther east in the vicinity of Sagua la Grande more dense material reaches the surface. Still farther south and east, at Santa Clara City and in the hills beyond, extensive deposits of solid asphaltum again appear. Roughly estimated, the tract of country exhibiting surface indications of fluid

bitumens of varying density, and yielding in a few instances still more fluid bitumens from wells, covers an area 150 miles long and 30 wide. Motembo, with its naphtha well, is near the center. Other wells and springs in large number throughout this tract have exhibited petroleum and maltha of varying density. It was my intention to have examined the principal localities where bitumen occurs throughout this region, but the rainy season with unusually heavy rains came on four weeks earlier than usual, rendering the portions of the country beyond the reach of railroads inaccessible. I, however, had

1

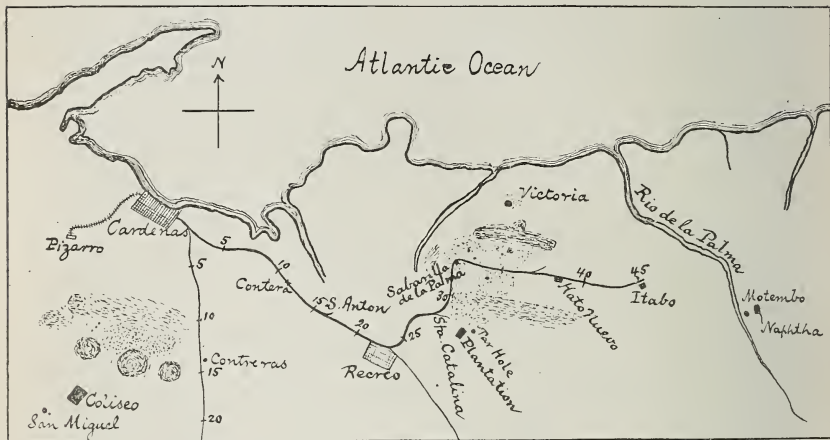

CÁRDENAS AND VICINITY (Pen sketch by the author).

the good fortune to spend some weeks in looking up a few of the places where bitumen occurs in the vicinity of Cárdenas, and to a distance of 40 miles to the eastward. The traveling was done by railroad and on horseback and enabled me to study the immediate surface of the country. The city of Cárdenas is built on a bay of the same name. The shores are low and consequently the bay is shallow. Both to east and west are swamps which in the rainy season are full of water.

Directly south of Cárdenas, some eight or nine miles, is a steep ascent, two or three hundred feet high, on the top of which is a plateau. This plateau extends still farther south to a higher range, 15 miles from Cárdenas. The country between the coast and the plateau first mentioned is level and dry, except a comparatively narrow strip bordering upon the ocean. A great deal of this country is rough, with a limestone that interferes with its cultivation, rendering it of little pecuniary value. This limestone is so plentiful that a great

many walls have been made of it to serve the purpose of fences. When in the ground it is soft and easily cut into blocks of any shape for building purposes. Put up in the soft state, it hardens in about a year and resists the elements for a very long time. Along with this limestone are seen outcrops of serpentine—a greenish mineral—soft and easily broken. The surface soil is a red clay and very productive. Among the trees the royal palm predominates, but there are also cocoanut trees, bananas, mangoes and others.

Looking at the accompanying map, we see this first range of hills directly south of Cárdenas. The trip to this range is best made on horseback. Reaching the plateau, it is found to be about four miles wide, covered with wild grass and royal palms.

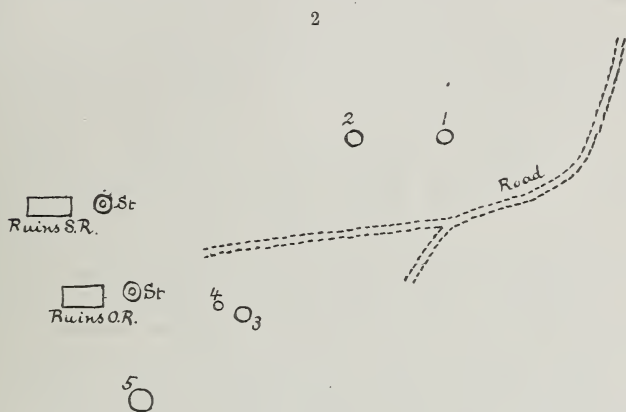

Sketch map of the Alvarez Oil Wells; showing also the ruins of the Sugar Refinery (S. R.), Oil Refinery (O. R.) and adjoining Stacks (St.)

Distance between No. 1 (oil and water) and No. 2 (water), 120 meters; between No. 2 and No. 3 (oil, 100,000 gallons), 320 meters; between No. 3 and No. 4, 320 meters; between No. 4 and No. 5, 150 meters.

The hills or low mountains still farther to the south are much higher than the first ascent and covered with trees to within a short distance of the top. To the right spreads an open country formerly cultivated but fast reverting to a wild condition. Directly in front we notice the ruined smoke stacks of two refineries. To the left is spread a broad expanse of this tableland covered with a very peculiar growth of royal palms. These trees, because of some lack of nourishment or deleterious substance in the soil, have been so stunted that they are of all heights, from a mere tuft of leaves sticking out of the ground to fifty or sixty feet; average height ten to twenty feet. This peculiar growth is indicated on the map by the dotted area. It is about five or six miles long and two broad.

Figure 2 gives a larger plan of the refineries just mentioned. These were owned and operated by a man named Alvarez, and

his associates. It is about five years since anything was done here. At the first Alvarez had only his house and the sugar mill. While digging a well for water (No. 1 on the map) they went down 78 feet, obtaining a water that was worthless because of a black thick oil found with it. This being unfit for drinking purposes, another well was dug at No. 2. Water was obtained at 78 feet with only a slight trace of oil. This well was used for water and furnished all there was on the premises. The water in this well is now 39 feet deep. For some years after this, Alvarez gave the oil from well No. 1 to the native population for various domestic purposes and especially for fuel. Then he with others conceived the idea of drilling a well for oil alone and refining it. An engineer and the necessary machinery were procured and well No. 3 drilled. A large hole was put down about 25 feet, inside of which a two-inch pipe was driven down 500 feet, when oil was obtained. A pump was then put in and 100,000 gallons extracted, which was all the well would yield. It was then decided to drill this well still deeper, but the drill became smeared with oil and drillings to such an extent that the drilling was stopped. To obviate this difficulty another well was put down at No. 4, three feet from No. 3, with the idea that when the same depth was reached at which the trouble occurred, the sticky stuff could be pumped out through No. 4 and drawn away from the drill in No. 3. The machinery was attached to the same walking-beam as that which was drilling No. 3, but when the same depth was reached as that of No. 3 no oil was found. No. 4 was then abandoned and another well put down at No. 5, 150 meters to the southwest of No. 3. This well was sunk to a depth of 180 feet, when the drill broke into a subterranean hole and the drills were lost. After some time spent in fruitless effort to recover the drills, everything was pulled up and taken back to well No. 3, to sink it still deeper by using better and improved machinery. An engineer was engaged from the United States to do the work, when one of the principal owners in the enterprise died and all operations were stopped. After the war broke out between Spain and the Cuban insurgents, both of the refineries were burned and nothing has been done there since. The foregoing history was told to me by one Juan P. de Torrontequi, who was one of those actively interested in all that was done. He now lives in Cárdenas. It shows that oil was found in two wells, one of which yielded 100,000 gallons, which were refined and sold to the people in the vicinity; also, that considerable work has been done in drilling, but in a very crude way.

At present the refineries and house are in ruins. The walls, chimneys, and portions of the machinery are all there is in

sight. Well No. 1 is eight feet in diameter walled down to the bed-rock and cut out of the rock for the rest of the distance. There are the remains of a wooden platform inside, about five feet down, which is covered with dirt and weeds. Vegetation is very rank all about it. Well No. 2 is ten feet in diameter, and has a high, strong stone coping around the top. Water at the bottom can easily be seen. Some water obtained from this well showed a trace of oil on the top. At well No. 3 about three feet of two-inch cast iron pipe sticking out of the ground is all that can be seen. Wells No. 4 and 5 have been filled up and all traces obliterated. The sample of oil obtained from No. 1 is very black, and of about the consistency of thin molasses with a strong odor.

After inspecting this property, I was shown a natural oil spring, a quarter of a mile distant from these wells, toward the poor land covered with stunted palms. A small stream or creek runs to the southeast, from the banks of which I saw oil oozing at several points. In appearance it was the same as that found in well No. 1. A Cuban told me that there were several such places along this creek and that the natural springs were plentiful in that vicinity.

Some time after the visit to the Alvarez property another trip was made to Sabanilla, about 30 miles directly east of Cárdenas. What was formerly the town of Sabanilla de la Palma is now a mass of ruins, so I went to Hato Nuevo, the next station to the east and 37 miles from Cárdenas. The way to reach this place is indicated on fig. 1 accompanying this report. As this tract is the largest I visited, I will describe my journey in detail. My interpreter and myself arrived in Hato Nuevo one afternoon about three o'clock. The next morning with two other men we set out to find the indications of bitumen. Following the railroad, we went west toward Sabanilla about two miles. Crossing the railroad, we struck out to the west in a zigzag course until, after riding about a mile, we arrived at a place where the ground is as hard as a floor and black with bitumen. There was a hole in the middle of this tract from whence issues a soft maltha that is very sticky. This has come out of the ground and flowed in all directions, saturating everything. Several other holes of a like nature were found and altogether covering nearly half an acre of ground. In one corner of this tract a square hole had been dug and walled up. During the late war this hole was fired and burned for four months until a heavy rain finally put it out. At present the ground for seventy or eighty feet around this hole is covered with coke. The well itself is full of water from rains and upon this floats masses of vegetation stuck together with the bitumen that comes from below. A pole shoved downward into the water eight or nine feet meets

resistance in a bed of soft, yielding material, and if this can be brought to the surface it is seen to be the same as that in the neighborhood. In the center of some of these springs were bubbles as large as walnuts which, when broken, quickly collapsed with some noise. Inside of the bubble was a small hole going down into the ground, indicating the possibility that the bubble was caused by gas. Many other overflows showed holes but no bubbles. The consistency of this material is like that of ordinary coal tar.

From this place we took a path in a southwesterly direction, through cane fields and waste lands, and after riding about three miles we reached an abandoned sugar plantation named Victoria. This place is a natural occurrence in a depression resembling a crater. The out-crops of bitumen here are not only larger in area than at the first place visited, but in quantity as well. There is also a hole here which had been dug, and during the war it was fired and burned for two months. A great deal of coke could be seen all around its edges. In at least two dozen places among a tall grass and low shrubbery, I saw holes from which bitumen was flowing in great quantity. Around some of them were beds of bitumen several feet in diameter, radiating quite uniformly from the center. The center was very soft and easily dug out. Upon several of the holes, as at the other place, I found bubbles which burst upon being struck. Our Cuban guide said these holes had been known for many years and that some of them had been much bigger than they are now. One of them in particular had caused the death of many cattle, which had fallen into it, and being unable to get out, had perished. The guide said the natives had been years trying to render this hole harmless to cattle by filling it with stones. It was then nearly full. All of the holes I saw covered, I should say, about two acres. Still farther to the west the guide pointed out a clump of palms, and said there were more holes under them. I did not go there. They were a mile and a half distant.

From here we struck out to the west, and a little south towards the railroad, to the ruins of Sabanilla de la Palma. The country through here is level and covered with a grass eighteen inches high. As we passed through here we saw several other depressions filled with water, and holes from which this same black, sticky stuff was flowing. Around the surface of some of these lagoons we observed bubbles constantly rising, indicating the presence of gas. One of these isolated holes is within one hundred feet of the railroad and shows considerable activity. On the south side of the track is another hole in the bottom of an excavation about twenty-five feet long, twenty feet wide, and six feet deep. This had been on

fire and burned for one month. Coke could be seen all about it, as at the other places. After a mere glance at this place, we took a path which led around the western end of the range of hills on the south side of the railroad, and after passing through a country overgrown with high grass and rank tropical vegetation, on what used to be a sugar plantation, we came out at another natural spring on a plantation near Santa Catalina, as indicated upon the map. Here is a natural spring and beside it a round hole ten feet in diameter, which was full of water. The guide said that this hole was almost bottomless and that the material had been used for repairing the buildings on the plantation half a mile distant. A fifteen-foot pole was shoved down into the water. At ten feet it struck the soft mass on the bottom. I shoved the pole still farther downward until there was scarcely a foot of the pole left in my hand, but no solid bottom was reached. This was the largest artificial well I saw and helped to prove to me that the evidences show this material to be well-nigh inexhaustible. From here we made our way back to Hato Nuevo as quickly as possible, and the next morning went back to Cárdenas.

The country where these evidences occur is very peculiar. The railroad from Recreo to Hato Nuevo passes through what resembles a river bottom. On the left are low hills in scattered clumps or standing quite alone. On the right the land is level until we reach the turn in the railroad at Sabanilla. Here a ridge commences and thence forward there are hills on both sides of the railroad to Hato Nuevo and beyond. This forms a plain between two ranges of hills. This plain is covered with the same kind of vegetation as that on the tableland south of Cardenas.

As the occurrences at Victoria are found on the north side of these hills, I am inclined to believe there are other bituminous hills between them and the coast. This embraces a territory of many square miles in extent.

I had very much wished to visit the celebrated naphtha well at Motembo, but the Rio de la Palma was so high as to be unfordable. I was told that the owner had done some drilling there in a very crude way and that the product was singularly pure. He used it like gasoline for heating and lighting his house. I have no personal knowledge of this place. The naphtha from this well has been gathered and distributed so widely as to be well known. It is of the specific gravity of ordinary benzine, and is absolutely colorless. A short description of the well and the locality surrounding it is to be found in the *Mineral Resources of the United States for 1898 and '99*. There is no question that this locality, as has been before stated, lying midway between two areas producing petroleum

and maltha, with solid asphaltum marking extremes still further removed from the center on either side, represents an unusual showing of bituminous deposits.

I was also told of another oil and water spring at San Miguel near Coliseo, twenty-one miles south of Cárdenas. As this spring was so full of water as to render it impossible to obtain any of the oil, I did not attempt to visit the place. A Cuban in Cárdenas who was familiar with the locality told me that the oil flows out of this spring into the water in such quantity as to cause cattle to refuse to drink the water.

It has been known for many years that solid asphaltum exists in the bottom of Cárdenas Bay. I was given a piece by a man in Cárdenas who said he had been mining it for many years and sold it in New York for from forty to seventy dollars a ton. It appears to be a very fine quality.

The occurrence of yellow fever at Santa Clara City prevented me from visiting that locality, but I was told there are large deposits of bitumen there. A sample of oil from a spring in this neighborhood called the "Sandal-wood Spring" was examined by Mr. H. N. Stokes in July, 1890, in the laboratory of the United States Geological Survey, in Washington, D. C. This examination was quite elaborate, and determined that the oil was closely allied to Russian oil. This gives the oil a value which, while it is a little inferior to the best Pennsylvania oils, is ranking among the best petroleum of the world, and particularly available for the preparation of lubricating oils.

Although I was unable to ascertain by personal examination the presence of liquid bitumens in the neighborhood of Sagua la Grande, I was assured by one whom I have every reason to believe, that there are very extensive deposits in the neighborhood of this town and extending eastward to Caibarien. This territory is fully if not quite as large as the one at Hato Nuevo.

From all of the information herein recited, obtained from varying and reliable sources, the following conclusions may be drawn:

That very extensive deposits of solid asphaltum exist near the north coast of Cuba. That springs and wells give indications of the existence of liquid bitumens of varying density, beneath the surface, over an area of some 4500 square miles. That the place in the modern geological series to which the formations in which the bitumens occur has not been determined, a fact of little practical importance, but the occurrence of fluid bitumens associated with serpentine has been before observed both in southern France and in California. The oil

which has been obtained resembles the oils of Russia, hence may be easily manufactured into commercial articles.

Remarks on the Same

By S. F. PECKHAM.

Having carefully read this paper upon the Bituminous Deposits of Cuba, and while expressing the fullest confidence in what is said therein, I am prepared, in consequence of my experience with such indications in California and elsewhere, for that reason, to make the following statements.

Until a sufficient amount of work has been done by parties personally interested in this property, to demonstrate beyond question the existence upon or under it of actual value, these surface indications, though exhibited on a large scale and over a wide area, are not in any manner in themselves a source of prospective wealth but are rather only an incentive to cautious and very careful prospective drilling. The wells that have been drilled, while demonstrating that oil can be procured by drilling, have been very moderate producers and extremely short-lived and are, therefore, quite as largely indications to extreme caution as a stimulus to even experimental outlay. It is doubtful if, in view of the enormous production which recent developments in Texas and Indiana promise, there is at present any encouragement for even experimental drilling in Cuba.

It has long been known that very extensive deposits of asphaltum exist in Cuba, but I have never seen a sample that I was sure came from there, that was of such quality as to compare well with varieties upon the market from other localities within the borders of the United States.

ART. IV. — *Mineralogical Notes, No. 2*; by AUSTIN F. ROGERS, Fellow in Mineralogy, Columbia University.

1. *Calcite*.*

(a) *New Types from the Upper Mississippi Lead Region*.—The calcite crystals occurring in the ore district of southern Wisconsin have been studied by Hobbs,† who distinguishes six types of crystals with 13 forms. In the Egleston Mineralogical Museum of Columbia University are three types not mentioned by Hobbs, including three forms not given by him.

The most interesting type is represented by two singly terminated crystals about $20 \times 30^{\text{mm}}$ with a fewer smaller ones, and are labelled "Shullsburg, Wis." The dominant form is the pyramid of the second order γ ($8 \cdot 8 \cdot \bar{1}6 \cdot 3$), a rare form for calcite first observed by vom Rath‡ on Andreasberg crystals, and later by Cesaro§ as a dominant form on crystals from

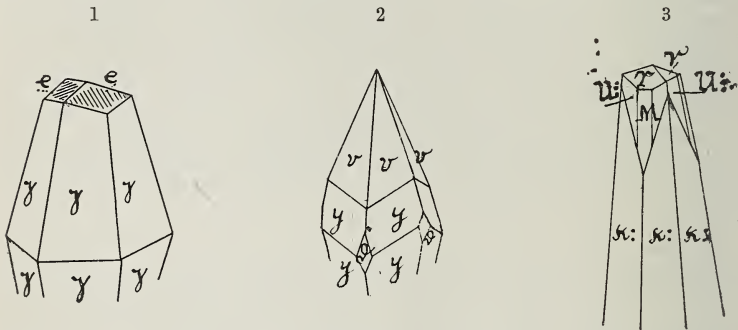

Rhisnes, Belgium. Hamberg|| also found it on crystals from Visby, Gotland, Sweden; and recently Penfield and Ford¶ described some siliceous calcites from Bad Lands, South Dakota, on which this pyramid is the dominant form. Penfield and Ford** have also described crystals from Union Springs, Cayuga Co., N. Y., on which this form is prominent.

The only other forms occurring on the Shullsburg crystals are the negative rhombohedron $\epsilon(01\bar{1}2)$, faces of which are

* Letters given by Dana in 6th Edition System are used for such forms as are mentioned therein. Goldschmidt's letters are used for the other forms. The letters for new forms are chosen in accordance with Goldschmidt's table on p. 141 of vol. i of his "Index der Krystallformen der Mineralien."

† Hobbs, *Zeitschr. f. Kryst.*, xxv, 258-261, 1895; also *Bull. Univ. Wis., Sci. Series*, i, 114-121, 1895.

‡ vom Rath, *Pogg. Ann.*, cxxxii. 521, 1867.

§ Cesaro, *Mem. l'Acad. Roy. de Belgique*, xxxviii, 8-14, 1886.

|| Hamberg, *Geol. Fören. Förhandl.*, xvi, 709-716, 1894.

¶ Penfield and Ford, *this Journal*, ix, 352-354, 1900.

** Penfield and Ford, *this Journal*, x, 237, 1900.

striated parallel to their shorter diagonal, and a narrow underdetermined negative scalenohedron beveling the alternate polar edge of γ . Figure 1 represents a crystal of this type.

One of the smaller crystals was used for the identification of the forms. It did not give very satisfactory images with the reflection goniometer, but the faces are identified.

		Average.	Calculated.
$\gamma \wedge \gamma^I$	$8.8 \cdot \bar{1}6 \cdot 3 \wedge 16 \cdot 8 \cdot \bar{8} \cdot 3$	$59^\circ 0'$	$58^\circ 28'$
$\gamma \wedge \gamma^{VI}$	$8.8 \cdot \bar{1}6 \cdot 3 \wedge 8 \cdot 8 \cdot \bar{1}6 \cdot \bar{3}$	$24^\circ 29'$	$24^\circ 46'$

The average of 10 measurements on the hand goniometer gave for $e \wedge e \cdot (0\bar{1}\bar{1}2) \wedge (1\bar{1}02)$ $45^\circ 54'$, the calculated being $45^\circ 3'$.

On another type of crystals 5 to 10^{cm} long, the forms v ($21\bar{3}1$), γ ($32\bar{5}1$), f ($02\bar{2}1$) and ϑ ($10 \cdot 0 \cdot \bar{1}0 \cdot 1$) occur. Ordinarily v is the dominant form as in figure 2, but at times γ assumes that rôle, while on several corroded crystals v is apparently absent.

Crystals of this type are from Mineral Point and Shullsburg, Wis., and Dubuque, Iowa. Measurements were made with the contact goniometer.

Still another type occurs at Mifflin, Wis. The forms are \mathfrak{R} : ($8 \cdot 4 \cdot \bar{1}2 \cdot 1$), v ($21\bar{3}1$), e ($01\bar{1}2$), r ($10\bar{1}1$), ϑ ($10 \cdot 0 \cdot \bar{1}0 \cdot 1$). \mathfrak{R} : the dominant form is rather rough, v is smooth, e is striated and r is very much corroded: ϑ is a very narrow form truncating the obtuse polar edges of \mathfrak{R} :. On account of their large size ($2\frac{1}{2}$ –5^{cm}) measurements were made with the contact goniometer with these results:

			Av.	Calc.	
\mathfrak{R} :	$\wedge \mathfrak{R}^I$	$(8 \cdot 4 \cdot \bar{1}2 \cdot 1) \wedge (\bar{8} \cdot 12 \cdot \bar{4} \cdot 1)$	5	$80^\circ 52'$	$81^\circ 20'$
\mathfrak{R} :	$\wedge \mathfrak{R}^V$	$(8 \cdot 4 \cdot \bar{1}2 \cdot 1) \wedge (12 \cdot 4 \cdot \bar{8} \cdot 1)$	4	$38^\circ 18'$	$38^\circ 2'$
\mathfrak{R} :	$\wedge \mathfrak{R}^{VI}$	$(8 \cdot 4 \cdot \bar{1}2 \cdot 1) \wedge (4 \cdot 8 \cdot \bar{1}2 \cdot \bar{1})$	6	$24^\circ 45'$	$24^\circ 21'$
v	$\wedge v^I$	$(21\bar{3}1) \wedge (\bar{2}3\bar{1}1)$	3	$75^\circ 30'$	$75^\circ 22'$
v	$\wedge v^V$	$(21\bar{3}1) \wedge (3\bar{1}\bar{2}1)$	3	$35^\circ 40'$	$35^\circ 36'$

(b) *Calcite with a new form from Colorado.*—Some calcite crystals from Seguahe Co., Colorado, obtained from Geo. L. English & Co., are different in habit from any described from this country (figure 3). The forms observed are $^*\kappa$: ($49 \cdot 41 \cdot 90 \cdot 8$), Π : ($24 \cdot 8 \cdot 32 \cdot 7$), r ($10\bar{1}1$), m ($40\bar{1}1$), e ($01\bar{1}2$), c (0001). $^*\kappa$: new for calcite, is the dominant form. The faces are bright and give excellent images except e and c , which are striated or roughened. These were identified by their position, the former truncating the polar edge of r . The following measurements made with the reflection goniometer identify the forms.

			Limits.	Average.	Calc.
κ :	$\wedge \kappa^I$	$(49 \cdot 41 \cdot 90 \cdot 8) \wedge (\bar{1}9 \cdot 90 \cdot \bar{1}1 \cdot 8)$	7	$65^\circ 28'$ – $65^\circ 30'$	$65^\circ 29'$
κ :	$\wedge \mathfrak{R}^V$	$(49 \cdot 41 \cdot 90 \cdot 8) \wedge (90 \cdot \bar{1}1 \cdot \bar{1}9 \cdot 8)$	6	$53^\circ 48'$ – $53^\circ 49'$	$53^\circ 48\frac{1}{2}'$
Π :	$\wedge M$	$(24 \cdot 8 \cdot 32 \cdot 7) \wedge (40\bar{1}1)$	3	$13^\circ 30'$ – $13^\circ 31'$	$13^\circ 30\frac{1}{2}'$
Π :	$\wedge \Pi^I$	$(24 \cdot 8 \cdot 32 \cdot 7) \wedge (\bar{2}4 \cdot 32 \cdot 8 \cdot 7)$	3	$88^\circ 48'$ – $88^\circ 49'$	$88^\circ 48\frac{1}{2}'$
r	$\wedge M$	$(10\bar{1}1) \wedge (40\bar{1}1)$	3	$31^\circ 9'$ – $31^\circ 11'$	$31^\circ 10\frac{1}{2}'$

There is no doubt as to the symbol given for κ : being the correct one though it is complicated. The images were excellent and the crystal was recentered several times. The nearest known form is $(6\cdot5\bar{1}\bar{1}\cdot1)$, for which the calculated angles are $65^\circ 36'$ and $53^\circ 40'$ instead of $65^\circ 29'$ and $53^\circ 48\frac{1}{2}'$ respectively.

(c) *New form on Calcite from Frizington, England.*—The small acicular calcite crystals from Frizington, Cumberland, England, seem not to have been described.

The forms identified are as follows: m $(10\bar{1}0)$, a $(11\bar{2}0)$, $^*\chi$ $(5\cdot5\bar{1}\bar{0}\cdot1)$, v $(2\bar{1}\bar{3}1)$, r $(10\bar{1}1)$, e $(01\bar{1}2)$, and a negative scalenohedron probably B $(2\cdot8\bar{1}\bar{0}\cdot3)$ and an undetermined dihedral prism. The pyramid of the second order χ , new for calcite, is the dominant form. The following measurements were made with a No. 2 Fuess goniometer with diminishing eye-piece. The measurements made over adjacent polar edges of the pyramid show conclusively that it is not a scalenohedron.

		Limits.	A v.	Calc.
$\chi \wedge \chi^t$	$(5\cdot5\bar{1}\bar{0}\cdot1) \wedge (10\cdot5\bar{5}\cdot1)$	4	$59^\circ 33' - 59^\circ 35'$	} $59^\circ 34\frac{1}{2}'$
$\chi \wedge \chi^v$	$(5\cdot5\bar{1}\bar{0}\cdot1) \wedge (5\cdot5\bar{1}\bar{0}\cdot1)$	4	$59^\circ 34' - 59^\circ 35'$	

(d) *Calcite Crystals from Eudora, Kansas.*—In cavities of the brachiopod fossil *Enteletes hemiplicata*, which occurs so abundantly in limestone at Eudora, Douglas Co., Kansas, are found small colorless calcite crystals.

The observed forms are σ $(5\bar{1}\bar{6}4)$, r $(10\bar{1}1)$, e $(01\bar{1}2)$, l $(04\bar{1}5)$, M $(10\bar{1}0)$, t $(2\bar{1}\bar{3}4)$, m $(10\bar{1}0)$. σ is ordinarily the dominant form, though sometimes r is. The faces are somewhat striated and otherwise imperfect. Consequently the measurements are not all good, but they serve to identify the forms without question.

			Average.	Calc.
$\sigma \wedge \sigma^t$	$(5\bar{1}\bar{6}4) \wedge (5\bar{6}\bar{1}4)$	2	$14^\circ 19'$	$14^\circ 27'$
$\sigma \wedge \sigma^v$	$(5\bar{1}\bar{6}4) \wedge (6\bar{1}\bar{5}4)$	2	$78^\circ 2'$	$77^\circ 54'$
$e \wedge l$	$(01\bar{1}2) \wedge (04\bar{4}5)$	2	$11^\circ 50'$	$12^\circ 2'$
$l \wedge m$	$(04\bar{4}5) \wedge (10\bar{1}0)$	2	$51^\circ 39'$	$51^\circ 43'$
$m \wedge M$	$(10\bar{1}0) \wedge (40\bar{4}1)$	2	$14^\circ 15'$	$14^\circ 17'$
$t \wedge e$	$(2\bar{1}\bar{3}4) \wedge (01\bar{1}2)$	1	$21^\circ 0'$	$20^\circ 58'$

(f) *Calcite Crystals from Kansas City, Mo.*—Dull opaque calcite crystals from 1 to 3^{cm} in length, occurring in a limestone at Kansas City, Mo., present some peculiar features. They are singly terminated and are always attached at the terminated end. The other end is hollowed out and occupied by parallel growths. They would scarcely be called crystals were not the rough faces seen to be definitely related to the cleavage planes. The forms are g $(05\bar{5}2)$ and n $(50\bar{5}1)$, rare rhombohedrons for

calcite. g consists of smooth narrow faces truncating the polar edges of n . The faces of the latter are very rough, channeled parallel to their intersection edge with g , and pitted. The angle $g \wedge n$ (cleavage face) $05\bar{5}2 \wedge 10\bar{1}1$ was measured with the following results, the contact goniometer being used.

Crystal	Measurements	Average.	Calculated.
1	8	$67^{\circ} 25'$	$67^{\circ} 30'$
2	6	$67^{\circ} 55'$	$67^{\circ} 30'$

The form n was identified by the fact that the g face truncates its polar edges, as measurements were not possible on account of the rough surface.

2. *A New Form on Galena.*

Several crystals of galena associated with sphalerite and calcite from an unknown locality are thought to be worthy of brief mention here. The forms present are the tetragonal

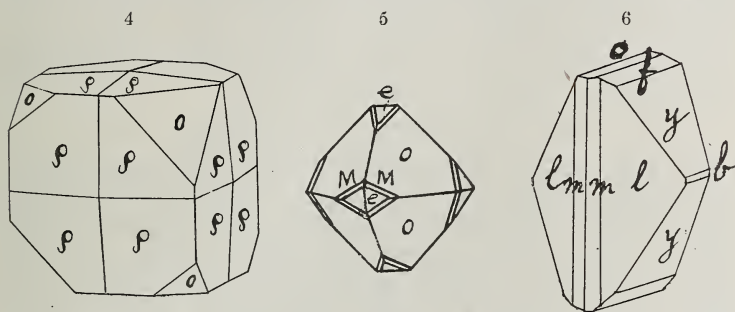

trisoctahedron $^*\rho$ ($13\cdot1\cdot1$) and the octahedron o (111). The crystals have a tetrahedral aspect due to the unequal development of the octahedral faces (fig. 4). ρ ($13\cdot1\cdot1$) is a new form for galena and is not mentioned as occurring on any isometric mineral in the 6th edition of Dana's System. It is striated parallel to its intersection edge with the octahedron, but good measurements were obtained, as the following table shows.

			Limits.	Average.	Calc.
$\rho \wedge \rho$	$13\cdot1\cdot1 \wedge 13\cdot\bar{1}\cdot1$	4	$8^{\circ} 44' - 8^{\circ} 48'$	$8^{\circ} 46'$	$8^{\circ} 46'$
$\rho \wedge o$	$13\cdot1\cdot1 \wedge 1\cdot1\cdot1$	3	$48^{\circ} 29' - 48^{\circ} 32'$	$48^{\circ} 30'$	$48^{\circ} 31\frac{1}{2}'$

3. *Pyrite Crystals from Weehawken, N. J.*

Occurring in the calcite veins of the trap near Weehawken, N. J., are found small crystals of pyrite with the following forms o (111), e (210), M (432), the latter as narrow faces truncating the edge e/o . Figure 5 gives an idea of their habit. The markings, equilateral triangles on o and isosceles triangles on e , are almost identical with the etch figures, and like them indicate

the symmetry of the crystal. The diploid is sometimes lacking and occasionally the pyritohedron and octahedron are in equal development, the crystals then simulating the regular icosahedron of geometry. On account of striations good images were not obtained, and in the case of the diploid the reflections had to be relied upon. The measurements are as follows:

			Average.	Calculated.		
M	$\wedge o$	432	$\wedge 111$	7	15° 16'	15° 13½'
e	$\wedge o$	210	$\wedge 111$	3	39° 14'	39° 14'
e	$\wedge e$	210	$\wedge 2\bar{1}0$	3	53° 29'	53° 7¾'

4. *A Topaz Crystal of Unusual Habit from Pike's Peak.*

A topaz crystal from Pike's Peak, Col., measuring ($25 \times 20 \times 15^{\text{mm}}$) differs in habit from most of the described crystals. See figure 6. The forms present are c (001), b (010), m (110), l (120), f (021), y (041), and a small undetermined pyramid of the unit series. l and y are the dominant forms and the crystal is lengthened in the direction of the a -axis. m and l are vertically striated and the other faces are dull. The forms were identified with the contact goniometer.

5. *A new locality for Leadhillite.*

The rare mineral leadhillite has been reported from but three localities* in this country. The writer here records the mineral from a new locality, namely the Cerro Gordo Mines, Inyo Co., Cal. It occurs as small imperfect crystals of a pale sea-green tint on a specimen associated with linarite and caledonite. The crystals are short prismatic or thick tabular, of hexagonal aspect, much resembling those from Granby,† Missouri. The following forms were observed: c (001), m (110), a (100), and a narrow face in the vertical zone which could not be identified on account of its small size. The crystals were not suitable for measurement. There is perfect cleavage parallel to c and the cleavage plates have a high pearly lustre. The mineral is soluble in HNO_3 with effervescence leaving a white residue.

6. *Linarite Crystals from California.*

No linarite crystals have been described from the United States though it is known to occur at three localities.‡ The crys-

* Newberry Dist., Spartanburg Dist., N. C., by Shepard. Dana Min. 6th edit, p. 922, 1892. Schultz Gold Mine, Arizona, by Penfield, *ibid.* Granby, Mo., Pirsson and Wells, this Journal, vol. xlviii, p. 219-226, 1894.

† Pirsson and Wells, *loc. cit.*

‡ Cerro Gordo mines, Inyo Co., Cal., Dana's System, 6th edition, p. 925, 1892. Stevenson Bennett mine, near Las Cruces, New Mexico, Farrington, Publications Field Columbian Museum, Geol. Series, vol. i, no. 7, p. 225, 1900. Galena, Kansas, Rogers, Kansas Univ. Quarterly, vol. ix A, p. 165, 1900.

tals from Cerro Gordo mines, Inyo Co., Cal., present the following forms: c (001), a (100), m (100), b (010), u ($\bar{2}$ 01), s ($\bar{1}$ 01). The crystals are very thin, being flattened parallel to the hemi-orthodome s ($\bar{1}$ 01) and are elongated in the direction of the b -axis. Good measurements were not obtained on account of narrow faces and multiple images, but they are sufficient to identify the forms as given above.

This mineral also occurs at the Alice mine, near Butte City, Mont., and at the Daly mine, Park City, Utah.

7. Caledonite Crystals from Montana.

Caledonite has been reported from the same three localities as linarite. Its occurrence at Mine la Motte, Mo., needs confirmation. The crystals examined are from the Alice mine, near Butte City, Montana. They resemble in habit those described by Farrington* from New Mexico. The forms are c (001), b (010), m (110), e (011), f (021), s (223), t (221), besides several undetermined vicinal forms between f and c and between t and m .

8. Highly modified Barite Crystals from Kansas City, Mo.

In cavities in limestone at Kansas City, Mo., are often found small crystals of barite. They are usually simple combinations of the common forms, but occasionally highly modified ones are found. One such measuring about $1\frac{1}{2}$ mm (fig. 7) was studied with the following results. The crystals are tabular in habit, being flattened parallel to the basal pinacoid. The forms are as follows: c (001), b (010), a (100), m (110), L (140), η (320), l (104), d (102), o (011), f (113), r (112), z (111), y (122). Not all the faces gave good images, but the forms are identified without doubt.

				Average.	Calculated.	
a	\wedge	d	100 \wedge 102	3	51° 6'	51° 8½'
l	\wedge	c	104 \wedge 001	5	21° 54'	21° 57'
c	\wedge	d	001 \wedge 102	3	38° 51'	38° 51½'
c	\wedge	o	001 \wedge 011	3	52° 38'	52° 43'
m	\wedge	z	110 \wedge 111	3	25° 39'	25° 41'
r	\wedge	c	112 \wedge 001	3	46° 10'	46° 6'
f	\wedge	c	113 \wedge 001	3	34° 45'	34° 43'
c	\wedge	y	001 \wedge 122	5	56° 51'	57° 1'
a	\wedge	m	001 \wedge 110	3	39° 11'	39° 11'
η	\wedge	m	320 \wedge 110	8	10° 29'	10° 39'
b	\wedge	L	010 \wedge 140	6	22° 40'	22° 14½'

* Farrington, loc. cit.

9. *Celestite Crystals from Salina Co., Kansas.*

The writer is indebted to Dr. J. W. Beede for some crystals of celestite obtained at a quarry east of Mentor, Salina Co.,

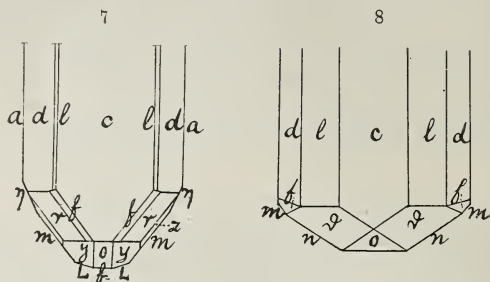

Kansas. As far as can be learned no celestite crystals have been described from Kansas, though it is a common mineral at several localities in the state.

The crystals, one of which is represented by fig. 8, are of the usual tabular habit elongated in the direction of the a -axis. The following forms were identified: c (001), b (010), m (110), n (120), l (104), d (102), o (011), f (113), and ϑ (124). ϑ (124), a prominent form on the crystals, is mentioned by Hintze.* m and n appear as narrow faces and did not give images. They were identified by their zonal relations and by appropriate measurements. The following are the results:

					Average.	Calculated.		
c	\wedge	l	001	\wedge	104	8	22° 17'	22° 20'
l	\wedge	d	104	\wedge	102	8	17° 3½'	17° 4½'
c	\wedge	o	001	\wedge	011	3	52° 2'	52° 0'
c	\wedge	f	001	\wedge	113	3	34° 50'	34° 46½'
c	\wedge	ϑ	001	\wedge	124	6	37° 16'	38° 26½'
ϑ	\wedge	ϑ	124	\wedge	124	4	38° 11½'	38° 7'

In conclusion the writer wishes to thank Prof. A. J. Moses for suggestions in the preparation of this paper.

* Hintze, Zeitschr. f. Kryst., vol. xi, 232, 1885.

ART. V.—A *New Solution for the Copper Voltameter*;
by WILLIAM K. SHEPARD.

THE importance of the convenient and accurate method of measuring electric currents by the voltameter depends very largely upon the construction of a voltameter which admits of high current densities.

The silver voltameter gives results of a high degree of accuracy, but is not conveniently used except for small currents; the copper voltameter, however, from the cheapness of its materials, finds employment in the laboratory for the measurement of comparatively large currents.

As ordinarily used, the copper voltameter is subject to irregularities due to the solvent effect of the solution in some cases and the oxidation of the copper in others. The voltameter solution recently investigated by the writer commends itself by the facts that these irregularities are avoided and that approximately twice the current density permissible with solutions hitherto in use may be employed without loss of accuracy, thus allowing large currents to be measured without inconveniently increasing the size of the electrolytic cell.

Many different solutions for the voltameter have been recommended by various experimenters. Gray,* using a copper sulphate solution of density 1.15 to 1.18 with one per cent free sulphuric acid, found that the highest current density desirable was .02 ampères per square centimeter of cathode surface.

Vanni† observed that a copper sulphate solution of density 1.12 with one per cent free sulphuric acid dissolved copper and therefore gave indications always too small. With an increase of the current density the deduced electro-chemical equivalent of the copper increased. A solution neutralized with copper hydrate, on the contrary, yielded results in constant excess, probably on account of the oxidization of the copper. By adding to a liter of the normal solution one half a gram of a solution which contained one per cent sulphuric acid, he found neither a gain nor a loss in the weight of a piece of copper immersed in it. With this solution he successfully used a current density of $.011 \frac{\text{amp}}{\text{cm}^2}$, but no experiments seem to have been made to determine the limit.

Oettel ‡ obtained smaller deposits of copper from copper sulphate solutions than Faraday's law demands resulting from

* Phil. Mag., xxii, p. 289, 1886.

† Wied. Annal., x, p. 214, 1891 and Phil. Mag., xxv, p. 179, 1888.

‡ Chemische Zeitung, p. 543, 1893.

the formation of oxygen compounds such as HSO_4 . By the addition of alcohol these losses were avoided. He advised as the best solution :

150	gms.	CuSO_4
50	"	H_2SO_4
50	"	Alcohol
1000	"	H_2O

Beach* investigated the use of copper nitrate in the voltmeter. His solution after neutralization had a density of about 1.53 and contained one drop of a saturated solution of NH_4Cl to 100cc. of the nitrate. The NH_4Cl was added to prevent the oxidization and consequent excess of deposit which occurs when a neutral solution is used alone. He found that he could use a much higher current density with this solution than with the copper sulphate solutions commonly used. But as copper nitrate is relatively expensive in comparison with the sulphate, it is not so well suited for general laboratory use.

It seemed to the writer of interest to attempt the use of a neutral solution of the sulphate in the same manner, with the aim of increasing the allowable current density. The solution was prepared as follows: A saturated solution of copper sulphate was boiled for a short time to expel the air and then kept at 100°C . for about an hour in contact with metallic copper in order to neutralize the solution. The density was then about 1.20. A very small amount of NH_4Cl was added, about .05 of one per cent.

Two voltmeters were used in the investigation. They were connected in series in order to see how the different solutions would agree when using exactly the same current. Each voltmeter consisted of three anode and two cathode plates, the cathode plates being placed alternately between the anodes at distances of about 2 centimeters. The plates were $10.5 \times 19\text{cm}$., of which a working cathode surface of about 600cm^2 was employed. The voltmeters were used in battery jars 20cm. high and 15cm. in diameter.

The method used in the preparation of the cathode plates was that given by Gray.† The edges and corners were well rounded and the plates polished with sand paper. They were next placed in water slightly acidulated with sulphuric acid for a short time to remove any trace of oxide, rinsed in clean water, dried with filter paper and then over a gas flame. After copper had been deposited, the plates were not exposed to the air for a time longer than absolutely necessary before the copper sulphate solution had been completely washed off. The reason

* This Journal, xlv, p. 81, 1893.

† Phil. Mag., xxii, 1886.

for this is that a copper plate oxidizes rapidly when wet with a solution of neutral copper sulphate and exposed to the air. This was accomplished by removing the voltameter plates as a whole from the solution and dipping at once into water containing a few drops of sulphuric acid. They were then rinsed in clean water, dried with filter paper and over a flame.

Gray's solution was first tried for comparison. Very good deposits were obtained using a current density up to about $\cdot 03 \frac{\text{ampères}}{\text{cm}^2}$; but the deposits would sometimes differ as much as one per cent in the two voltameters.

Oettel's solution gave fine deposits for low current densities. When, however, the current density was increased the plates blackened badly and copper was found in the form of powder on the bottom of the jars. The highest current density permissible with this solution was $\cdot 02 \frac{\text{ampères}}{\text{cm}^2}$.

Then the solution with NH_4Cl prepared as above was investigated in the same manner. For low current densities it gave as good results as had been obtained with either Gray's or Oettel's solution, but, in contradistinction to these, the results continued to be satisfactory when these limits were widely surpassed. With a current of 20 ampères the density was increased, by raising the plates so as to lessen the immersed surfaces to a value even more than $\cdot 05 \frac{\text{ampères}}{\text{cm}^2}$. Notwithstanding this very material increase in the demands upon the voltameter, the deposits still remained perfectly satisfactory. With 30 ampères and a current density of $\cdot 045 \frac{\text{ampères}}{\text{cm}^2}$ the solution still gave results differing by less than one per cent.

The voltameters were then filled, one with Gray's or Oettel's solution and the other with the new solution. When employed for low current densities the solutions in all cases gave deposits agreeing within the limits of error imposed by the methods employed.

With regard to the constancy of the apparent electro-chemical equivalent when a high current density was used with this solution, no exact statement can be made, as the absolute measurement of the current was not attempted. In the first part of this investigation a Weston ampère-meter was included in the circuit, the error of which the writer has reason to believe was less than one per cent. Assuming the indications of this instrument to give the true values of the current, the electro-chemical equivalent obtained from the new solution was fairly constant.

The results are not given, as different values of the current being used they included the errors of the instrument.

Having now performed these preliminary experiments showing that the solution could be employed for large current densities without loss of accuracy and having obtained a fair idea of the working of the solution, experiments were begun with the aim of eliminating the error of the instrument.

Another Weston ampère-meter was obtained which read only to 15 ampères, each ampère division being divided into ten parts. So that with this instrument the current could be measured with an error in the reading of less than $\frac{1}{10}$ th of an ampère. The instrument was not assumed to be correct, but after the experiments had been finished the results were averaged, and taking the electro-chemical equivalent of copper to be $0.00329 \frac{\text{gm.}}{\text{amp. sec.}}$ the true value of the current at the division used on the instrument was obtained.

Only one point on the ampère-meter was used, namely, the one which gave the nearest value to 15 ampères. Thus with the same division and changing the current density by raising the immersed surfaces of the voltameter plates, the error of the instrument was eliminated.

From what has just been said, it will be plain that the results given below are not presented as determinations of the electro-chemical equivalent of copper; the experimental data are reduced to that form simply for convenience in comparing them.

The current was obtained from a storage battery of 50 cells, and was kept constant by means of a copper sulphate resistance which could be varied at will by varying the distance between the copper plates.

An auxiliary circuit was arranged whose resistance was equal to that of the two voltameters. The current was thrown by means of a switch first through the auxiliary circuit to the ampère-meter and resistances included in the circuit. These were allowed to heat up until everything became constant and the resistance adjusted so as to give the desired reading of the ampère-meter. Then the current was thrown through the voltameters and assumed the desired value instantly.

The duration of an experiment was 20 minutes, so that a deposit of about 6 grams was obtained. This deposit showed no oxidization even up to the highest current density used which was greater than $0.07 \frac{\text{amp.}}{\text{cm}^2}$.

The results are arranged in series according to their respective current densities, as follows :

SERIES I.

Current Density = $\cdot 02 \frac{\text{ampères}}{\text{cm}^2}$

No.	Equivalent $\times 10^7$.
1	3287.2
2	3295.0
3	3288.4
4	3288.9
5	3292.8
6	3297.2
7	3286.8
8	3288.4
9	3293.9
10	3289.4
11	3287.2
12	3293.4

The mean of these values is 3290.7 with a probable error of ± 2.4 for a single observation.

SERIES II.

Current Density $\cdot 03 \frac{\text{amp}}{\text{cm}^2}$

No.	Equivalent $\times 10^7$.
1	3288.4
2	3291.7
3	3296.7
4	3291.7
5	3292.8
6	3288.3
7	3295.5
8	3295.9
9	3294.4
10	3287.2
11	3288.4
12	3288.9

The mean of these values is 3291.7 with a probable error of ± 2.3 for a single observation.

SERIES III.

Current Density $\cdot 04 \frac{\text{amp}}{\text{cm}^2}$

No.	Equivalent $\times 10^7$.
1	3287.8
2	3294.4
3	3287.2
4	3284.5
5	3283.9
6	3283.4
7	3296.7
8	3295.0
9	3292.2
10	3295.5
11	3296.1
12	3296.7

The mean of these values is 3291.1 with a probable error of ± 3.6 for a single observation.

SERIES IV.

Current Density $\cdot 05 \frac{\text{amp}}{\text{cm}^2}$

No.	Equivalent $\times 10^7$.
1	3286.2
2	3286.2
3	3290.5
4	3293.4
5	3288.4
6	3286.8
7	3297.2
8	3292.8
9	3285.5
10	3287.2
11	3286.8
12	3293.4

The mean of this series is 3289.5 with a probable error of ± 2.6 for a single observation.

SERIES V.

Current Density $\cdot 06 \frac{\text{amp}}{\text{cm}^2}$

No.	Equivalent $\times 10^7$.
1	3288.4
2	3294.4
3	3287.2
4	3290.0
5	3292.8
6	3290.5
7	3291.7
8	3295.0
9	3283.9
10	3287.2
11	3287.2
12	3291.1

The mean of these values is 3290.0 with a probable error of ± 2.2 for a single observation.

SERIES VI.

No.	Current Density $\cdot 07 \frac{\text{amp}}{\text{cm}^2}$	Equivalent $\times 10^7$.
1	-----	3291.7
2	-----	3288.9
3	-----	3291.1
4	-----	3286.2
5	-----	3290.5
6	-----	3290.0
7	-----	3287.2
8	-----	3286.2
9	-----	3290.5
10	-----	3292.8
11	-----	3286.2
12	-----	3282.8
13	-----	3291.7
14	-----	3287.2
15	-----	3292.2
16	-----	3288.3

The mean of these values is 3289.0 with a probable error of ± 1.9 for a single observation.

The results are arranged for comparison in the following table :

Series.	Current Density.	Mean.	Prob. Error of Mean.
I	$\cdot 02$	3290.7	± 0.7
II	$\cdot 03$	3291.7	± 0.7
III	$\cdot 04$	3291.1	± 1.0
IV	$\cdot 05$	3289.5	± 0.7
V	$\cdot 06$	3290.0	± 0.6
VI	$\cdot 07$	3289.0	± 0.6

These results show no dependence upon the current density. In fact, series VI, which differs most from the others, could be slightly increased for the following reason. The day after this series was taken the watch which had been used to measure the time was rated with a clock and found to be gaining at the rate of 2 seconds an hour when lying at the side of the ampère-meter. This was doubtless caused by the magnetic field of the ampère-meter, as the watch at other times was very correct.

If a connection were applied for this to series IV it would increase it by about one part in 1800, so that it would become 3290.6, which is in still closer agreement. During series III, IV, V, which were taken after this fact had been discovered, the watch was rated and proper connections were applied. But as the watch had not been rated during series I, II and VI, the corrections cannot be applied to them.

It is also proper to observe that although the current density was widely varied there is no loss of accuracy, as is shown by the probable errors of a single observation in the different series.

For current densities of $\cdot 05 \frac{\text{amp}}{\text{cm}^2}$ or greater the solution was found to heat a little during the first experiment. Results which were obtained during the rise in temperature of the solution were always slightly greater than those obtained after the solution had become warm and at a uniform temperature throughout. The unequal temperature of the solution may be avoided by stirring or by making a preliminary experiment to warm up the solution. The best way was found to heat the solution by means of a flame to a temperature of about 35 or 40° C. before making an experiment. The deposits were then found to be very satisfactory even up to a current density of over $\cdot 07 \frac{\text{amp}}{\text{cm}^2}$ and the resulting values of the equivalent to agree closely with those obtained with the low current densities.

The results given in series III, IV, V and VI were obtained with the solution at a temperature from 35° to 40° C., while series I and II were obtained with the solution at the temperature of the room, about 20° C. We see therefore that the temperature from 20° to 40° C. has practically no influence upon the results given by the solution; but that any *inequality* in the temperature of the solution will cause slight errors and therefore should be carefully avoided.

The same solution was used throughout the second part of this investigation. Perhaps fresh solutions would have given more consistent results, but certainly no large error is introduced by the repeated use of the solution.

We may collect the results with this solution as follows:

The weight of copper deposited is practically independent of the temperature between 20° and 40° C.

The results are independent of the current density within the limits given.

The solution may be used a large number of times.

The solution may be used with a current density two or three times as great as that permissible with others commonly in use, so that to measure a given current a considerably smaller voltmeter may be employed than with the older solutions.

Current-measuring instruments may be calibrated by its means with an error of only about one-tenth of one per cent.

Sheffield Scientific School, New Haven, Conn.

ART. VI. -- *The Thermo-magnetic and Galvano-magnetic Effects in Tellurium*; by MORTON GITHENS LLOYD, Ph.D.

THE investigations here described were begun with the idea of measuring all of the thermo-magnetic and galvano-magnetic effects in the same specimen of a non-metal, tellurium being the substance chosen. It has heretofore been investigated for only two of the transversal effects. Satisfactory numerical values of the magnitude of most of these effects have not yet been obtained, owing to the difficulties involved in their measurement, but as the work must be interrupted for some time, it is thought best to publish the qualitative results at once.

If a conducting plate carrying an electric current be placed in a magnetic field perpendicular to the lines of force, the following galvano-magnetic effects have been observed.

1. A difference of electric potential is produced between the edges of the plate, perpendicular to the direction of the current and of the magnetic field. (Hall effect.)

2. A difference of temperature is produced between the same points.

3. A change of resistance occurs. (Longitudinal Hall effect.)

4. A difference of temperature is produced in the direction of the current.*

If a flow of heat replace the primary electric current, four analogous thermo-magnetic effects are observed.

1. A difference of electric potential between the edges of the plate.

2. Rotation of the isothermal lines or a difference of temperature between the same points.

3. A change of conductivity for heat.

4. A difference of potential in the direction of the heat-flow. (Longitudinal thermo-magnetic effect.)

The transversal effects are reversed in direction when either the magnetic field, or the primary current of heat or electricity, is reversed in direction; but the longitudinal effects are independent of the direction of the field.

It has already been proposed† to call the galvano-magnetic temperature-difference, the thermo-magnetic temperature-difference, and the thermo-magnetic potential-difference by the respective names, Ettingshausen effect, Leduc effect and Nernst effect. Most of these effects were first observed in bismuth, and some of them only in bismuth. The change of conduc-

* Nernst, Wied. Ann., xxxi, p. 784, 1887.

† Thesis: The Transversal Thermo-magnetic Effect in Bismuth, M. G. Lloyd, Philadelphia, 1900; Beiblätter, 24, p. 1014.

tivity for heat was first announced by Righi* and shortly afterward by Leduc.† The Leduc effect has been observed by Leduc,† Righi,‡ and van Everdingen.§ The Nernst effect, discovered by von Ettingshausen and Nernst,|| has been observed by van Everdingen, Yamaguchi,¶ Moreau** and the writer, these observations covering a number of metals. The Ettingshausen effect was observed by its discoverer †† in bismuth, antimony and tellurium, and was included in van Everdingen's observations on bismuth. The longitudinal thermo-magnetic effect has been observed in bismuth by von Ettingshausen and Nernst, van Everdingen,‡‡ and Lownds.§§

Chemically pure tellurium was obtained from Eimer and Amend, and cast into the form of a plate, 6.7^{cm} long, 2.5^{cm} wide and 0.1^{cm} thick, with two lugs projecting from the middle of the lateral edges. Six thermo-electric couples of copper and German silver wire made electric connection with the plate; one to each of the lugs, the other four along the center line of the plate, separated by distances of 15, 13, 18^{mm}. These couples served to determine the temperature at the six points and thus the temperature-gradient, and in addition could be used to determine the difference of potential between any two points. The ends of the tellurium plate were pressed by springs against projections from two brass tubes, through which steam and cold water, respectively, could be passed. The whole was mounted on a wooden frame, and suspended between the poles of a powerful electro-magnet. The pole-faces were 6.3^{cm} square and 1.3^{cm} apart, and the magnetic field between them practically uniform. The strength of field was determined from the resistance of a calibrated bismuth spiral which was also attached to the wooden frame. When sending an electric current through the plate, cold water flowed through both brass tubes, to which the lead-wires were attached. Differences of potential were measured by comparison with a standard Clark cell, using the potentiometer. A very sensitive astatic reflecting Thomson galvanometer was used as a current-indicator.

The electromotive force, *E*, in microvolts, of a thermo-electric circuit of copper and German silver, one junction of

* Rend. Acc. Lincei, iii, p. 481, 1887; Beiblätter, 11, p. 670.

† Comptes Rendus, civ, p. 1783, 1887.

‡ Rend. Acc. Lincei, iii, p. 6, 1887.

§ Proc. Royal Acad. Sci. of Amsterdam, i, p. 72, 1898; Comm. from Leiden, No. 42.

|| Anz d. kais. Akad. Wien, xiii, p. 114, 1886; Wied. Ann., xxix, p. 343.

¶ Ann. d. Physik, i, p. 214, 1900.

** Journal de Physique ix, p. 497, 1900.

†† Wied. Ann., xxxi, p. 737, 1887.

‡‡ Ann. d. Physik, iv, p. 776, 1901.

§§ Leiden Comm., No. 48; Proc. R. A. S. A., Mar. 25, 1899.

which is at 25° C. and the other at T°, has been found by Dr. H. C. Richards to be

$$E = 15.20 (T - 25) + 0.0272 (T - 25)^2.$$

One of the couples used in this work was tested between 0° and 100° and found to agree with the formula, which has been used in determining temperatures.

The plate was insulated and protected from air-currents as well as possible by the use of mica, asbestos, cotton, etc.

Ettingshausen effect.—If the primary current flow from right to left, and the lines of magnetic force are directed away from the observer, the upper edge of the plate is cooled and the lower warmed. This is in the same direction as in bismuth. The effect was measured by passing current through the plate between the two tubes, and observing the temperatures at the edges of the plate for both directions of the field, giving time in each case for temperatures to become constant. A series of readings was taken, reversing field each time, in order to eliminate any error due to the gradual change in temperature of the whole plate. Readings in zero field were not used in the calculations. They showed, however, that the effect was not symmetrical, i. e., the change for one direction of the field was not the same as for the opposite direction of the field; starting with zero field in both cases. The coefficient of the Ettingshausen effect, P, is defined by the equation

$$T = PH \frac{C}{t}$$

where T is the difference in temperature produced, by a change of field H, between the edges of a plate of thickness t when traversed by a current C. Temperatures are measured in Centigrade degrees; other quantities in C.G.S. electromagnetic units. The values of P observed ranged between 0.00014 and 0.00029 for fields up to 5500 gausses, at a temperature of about 65°. The high resistance of tellurium causes a correspondingly large generation of heat and the temperature of the interior is considerably higher than that of the surroundings. The flow of heat from the center of the plate to the edges (cooled by water flowing through the tubes) will produce a Leduc effect which may interfere with the measurements of the Ettingshausen effect. In this case the measurements were made at the center of the plate, where the temperature-gradient may be assumed zero.

Hall effect.—If the primary current flow from right to left, and the lines of force are directed away from the observer, the upper edge is at the lower potential. This direction coincides with the results of other observers and is usually considered as

positive. It is in the opposite direction in bismuth. To determine the Hall effect, the difference of potential was measured between the copper wires connected to opposite edges of the plate. This P.D. includes the thermo-effect due to the two points of contact not being at the same temperature. If the temperature remained constant, the thermo-effect could be eliminated by taking readings for both directions of the field. But the temperatures are not constant, the Ettingshausen effect producing a change whenever the field is reversed, and this must be allowed for. It was found in this case to affect the second significant figure by one unit only and hence is neglected. The coefficient of the Hall effect, R , is defined by the equation

$$E = RH \frac{C}{t}$$

In a field of strength 4,000 gausses, the value of R found was 430 C.G.S. at a temperature of 65° .

Change of resistance.—The resistance was determined by the difference of potential of two points between which a current was flowing. The current and P.D. were measured with Weston ammeter and voltmeter. The accuracy of the observations would serve to determine a change in resistance of one-half of one per cent. No change was found in fields up to 5,500 gausses. Other observations* on tellurium show an increase in resistance less than this.

Leduc effect.—If the heat flow be from right to left and the lines of force are directed away from the observer, the upper edge of the plate is cooled. The direction in bismuth is the reverse of this. The coefficient of the Leduc effect, S , is defined by the equation

$$T = SbH \frac{d\tau}{d\lambda}$$

where b is the breadth of the plate and $\frac{d\tau}{d\lambda}$ the longitudinal temperature-gradient. Values of S between 0.000002 and 0.000005 were obtained at temperatures between 30° and 38° in fields of strengths from 2,500 to 5,200 gausses. The coefficient appears to increase with the temperature.

Nernst effect.—If the heat flow be from right to left, and the lines of magnetic force are directed away from the observer, the upper edge is at lower potential. In bismuth the direction is the same. The coefficient of Nernst effect, Q , is defined by the equation

$$E = QbH \frac{d\tau}{d\lambda}$$

* Goldhammer, Wied. Ann., xxxi, p. 360, 1887.

The difference of potential between the copper leads connected to opposite edges of the plate is the resultant of the Nernst effect and the thermo-electric effect at the two junctions. Since the two junctions are in general at slightly different temperatures, they do not balance one another. If their temperatures were constant, the thermo-electric effect could be eliminated by taking readings for both directions of the magnetic field; for in one case the Nernst effect would be added to it and in the other case subtracted. Owing to the Leduc effect, the temperatures do not remain constant, but are altered by reversing the field.

Let E =Nernst effect; V and V' =the observed P.D.'s for two directions of the field; ϵ =thermo-electric power for copper and tellurium; t_1 and t_2 =the temperatures of the two junctions for one direction of the field, t_1' and t_2' for the other;

T =Leduc effect= $\frac{1}{2}(t_1 - t_1' + t_2' - t_2)$. Then

$$\begin{aligned} V &= \epsilon(t_1 - t_2) + E \\ V' &= \epsilon(t_1' - t_2') - E \end{aligned}$$

whence

$$E = \frac{V - V'}{2} - \epsilon T.$$

It is thus seen that the observed values of V must be corrected for the Leduc effect. In bismuth this correction was found negligible; in tellurium it is not so, owing to the enormous thermo-electric power of copper and tellurium, but assumes a magnitude of the same order as the Nernst effect. An accurate determination of the Nernst effect requires an accurate knowledge not only of one value of this thermo-electric power, but also of its variation with temperature and with strength of field. The values of ϵ observed are slightly over 600 microvolts, whereas the value usually given is about 500.

Observations of the Nernst effect give a value of $Q=0.36$ at 33° in a field of about 3,000 gauss. As in the case of the Hall effect the constant is larger than has been observed in any metal.

Change of heat-conductivity.—The conductivity is lessened in the magnetic field. The relative conductivities were calculated from observations of temperature at four points along the center line of the plate, assuming the thickness to be uniform and the surface-conductivity to be constant. Neither of these conditions is fulfilled, and hence the results are only approximate. The ratio of conductivity in a field of strength 4700 gauss to that in zero field was found to be 0.9.

Longitudinal thermo-magnetic effect.—The warm end of the

plate is at the higher potential. This direction is the same as Lownds* has found in bismuth at ordinary temperatures.

Two suggestions have been made† which might explain the origin of the longitudinal effects. One is, that the thermo-electric-power is altered in a magnetic field. Lownds has demonstrated that the effect observed by him cannot be so explained. The other suggestion is, that owing to a change in heat-conductivity, the temperatures at the junctions are changed, thus changing the E.M.F. in circuit. This explanation is plausible where the effect was measured by compensating the E.M.F. in zero field, and observing the change produced by the field. Lownds does not mention whether he made any test of this possibility, but in one of his experiments at least (p. 779) it is evident that the E.M.F. could not have had this origin.

The longitudinal effect has been observed in bismuth also by van Everdingen,‡ and found to vary with the strength of field according to the same law as the variation of resistance.

In my own experiments the temperatures at the junctions were observed in the given field as well as in zero-field, and allowance made for the change. Theory§ indicates that longitudinal effects should be proportional to the square of the strength of field, and independent of its direction. I have noticed that in every case the effect was greater for one direction than for the other. The mean value for a field strength of 2750 gaussess, mean temp. = 39°, difference of temp. = 19°, was 1050 microvolts.

If we regard the transversal differences of temperature and potential as due to the transfer of heat and electricity respectively across the plate, we notice that in tellurium the transfer of electricity is always in the same direction as the transfer of heat. That is, the edge which is raised in potential is also raised in temperature. Moreover, to produce the same effects with a current of electricity as with a current of heat, the direction of flow must be the same for both. For example, the edge which is warmed by the Leduc effect has its potential increased by the simultaneous Nernst effect. And to warm the same edge by the Ettingshausen effect as by the Leduc effect, the primary currents of electricity and heat must have the same direction.

In bismuth, the reverse is the case, the heat and electricity being transferred in opposite directions. Thus the edge which is warmed by the Leduc effect has its potential lowered by the simultaneous Nernst effect. And to warm that same edge by

* *Ann. d. Phys.*, iv, p. 776, 1901.

† Grimaldi, *Nuov. Cim.* (3), xxii, p. 5, 1887; Goldhammer, *l. c.*

‡ *Leiden Comm.*, No. 48, 1899. § *Drude, Ann. d. Physik*, iii, p. 377, 1900.

the Ettingshausen effect would require a primary electric current in the direction opposite to the heat flow producing the Leduc effect. These facts are of especial interest in connection with Liebenow's* theory of thermo-electric currents, in which he arrives at the conclusion that in metals heat always flows with the *negative* electricity, whereas in non-metals it accompanies the *positive* electricity. If this relation between the directions be a general one, a knowledge of the direction of any one of the four transversal effects would be sufficient to determine the direction of the other three. Of the eleven elements examined by Nernst† for the Nernst effect, six (Bi, Sb, Ni, Fe, Zn, Pb) bear out this relation with the Hall effect, if we regard antimony as a non-metal. Of the other five, three (Cu, Ag, Sn) showed such a small effect that they may be regarded as doubtful. The two notable exceptions are carbon and cobalt. It has been already noted by several writers‡ that cobalt occupies an anomalous position as regards its Hall-constant, and it may be that the Ettingshausen effect is large enough in this metal to entirely vitiate the measurements which have been made of its Hall-effect, even to changing the sign. In this regard it is to be noted that the thermo-electric-power is large between cobalt and copper, the metal usually used for lead-wires. Or the measurement of Nernst effect may have been equally influenced by Leduc effect. Moreau (*l. c.*) however, found an opposite direction for the Nernst effect in cobalt, which would make it agree with the general rule. The direction of the Ettingshausen effect in antimony is in harmony with the other effects.

This idea comes in conflict, however, with the "Electronentheorie" of Drude,§ which requires that the Ettingshausen effect be in the same direction in all metals. For the above relation to hold, the Hall-effect must also be in the same direction in all metals, which we know is not the fact. In the only three substances yet examined, bismuth, tellurium and antimony, the direction of the Ettingshausen effect has been found the same.

I summarize the constants for the four transversal effects.

		H_{\max}	t
Ettingshausen ----	$P = 0.0002$	5500	65.
Nernst -----	$Q = 0.36$	3000	33.
Hall -----	$R = 430.$	4000	65.
Leduc -----	$S = 0.000004$	5200	30-38

* Wied Ann., lxxviii, p. 316, 1899.

† Wied. Ann., xxxi, p. 760, 1887.

‡ Von Ettingshausen u. Nernst, Wiener Berichte, xciv, p. 560, 1886; J. C., Beattie, Proc. Royal Soc. Edinburgh, xx, p. 481, 1895; Drude, Ann. d. Phys., iii, p. 392, 1900.

§ Ann. d. Physik, iii, p. 369, 1900.

ART. VII.—*Additions to the Avifauna of the Bermudas with diagnoses of two new Subspecies*; by A. HYATT VERRILL.

DURING a recent collecting trip to the Bermudas, from March 10th to May 9th, 16 species of birds were observed that appear not to have been previously recorded:

Phaëton aethereus. Red-billed Tropic-bird. Several were seen on Harrington Sound in April.

Larus glaucus. Glaucous Gull. A large flock remained some time. Seen about the islets in Harrington Sound early in March. Were regarded as something new by the inhabitants.

* *Melanerpes Carolinus*. Red-bellied Woodpecker, Chab. Seen April 8th, on a Pride of India tree.

Passer montanus. European Tree-sparrow. Locally common in Paget Parish. Naturalized; resident. Probably introduced with the English Sparrow.

Carduelis carduelis. European Goldfinch. Abundant on the southern and eastern parts of the islands, especially about Hungry Bay. Accidentally introduced about 1885, from a wreck. Previously recorded by Reid as an escaped cage-bird.

Spinus tristis. American Goldfinch. Resident. Not uncommon. Intentionally introduced about 1896, near Hungry Bay.

Spizella monticola. Tree-sparrow. A flock was seen several times at Hungry Bay during the latter part of March.

Sitta Carolinensis. White-breasted Nuthatch. Seen April 14th to 30th, on cedars at Harrington House.

Dendroica Pennsylvanica. Chestnut-sided Warbler.

Dendroica striata. Black-poll Warbler.

Dendroica Blackburnia. Blackburnian Warbler. The last three were seen in flocks of other migrants, March 12th to 15th, at Hamilton.

Saxicola ananthe. Wheatear. Introduced recently near St. Georges. Appears to be perfectly naturalized. Previously recorded by Reid as a rare migrant.

Mimus polyglottus. Mocking Bird. Resident. Introduced about 1892, at Bailey Bay. Not uncommon at Walsingham and Paynter's Vale. Appears to be now naturalized.

The following four species were identified from the local collection in the Public Library at Hamilton: Orchard Oriole; Thrasher or Brown Thrush; Blue Jay; Red-shouldered Hawk.

The abundant resident Ground Dove proves to be the Bahama subspecies (*Columbigallina passerina Bahamensis*). It always has a black bill.

The resident Bluebird is decidedly larger and brighter colored than the true *sialis*. It is a new subspecies.

Sialia sialis Bermudensis A. H. Verrill.

Blue of the upper parts of male brilliant purplish azure, a little brighter on rump; chin light blue. Breast, sides and flanks deep purplish-cinnamon, much darker and richer than in North American specimens. Female more brownish with brighter rump and back than in the true *sialis*. Edge of wing, at carpal joint, distinctly pure white.

Length, 6.75 to 7.5 inches; wing, 4 to 4.25; tail, 2.75 to 3.25. Nest usually built in crevices and holes of cliffs; eggs usually pure white, rarely tinged with greenish-blue.

The resident cardinal bird of Bermuda also differs as a subspecies, from the American forms:

Cardinalis cardinalis Somersii A. H. Verrill.

Adult male: Lower parts brilliant orange-vermillion, brighter and more orange than in *C. cardinalis*. Upper parts are also clearer and brighter, deep lake-red, with scarcely any gray on tips of feathers. Vermillion of checks and crest brighter and clearly defined. Bill deep scarlet. Female lighter than in *cardinalis*, especially below; breast buffy yellow; belly almost pure white; upper parts clear ashy gray; crest and ear-coverts strongly tinged with red; wings and tail nearly as in the male.

Length, 8.75 inches; wing, 3.75; tail, 4.75; culmen, 0.80.

ART. VIII.—*The Induced Alternating Current Discharge studied with Reference to its Spectrum and especially the Ultra-Violet Spectrum*; by A. W. WRIGHT and E. S. DOWNS.

IN some experiments made in this laboratory a few years ago, in photographing the spectrum of an induced alternating current discharge, produced under special conditions between copper terminals, a plate was obtained which contained a very great number of lines. The primary purpose of this investigation was to locate these lines and if possible discover their origin, and secondly to study this peculiar form of discharge when produced on a very large scale. Spottiswoode* was among the first to give an account of this mode of exciting an induction coil by the direct application of an alternating machine, without the intervention of a contact breaker or the use of a condenser. In the Proceedings of the Royal Society† he points out some peculiarities of the discharge which he noted.

In our experiments the induction coil was used without a contact breaker or condenser. It had four hundred and twelve turns of wire about 3^{mm} in diameter for its primary, and a secondary of about 25.5^{cm} in length, consisting of about fifty thousand turns of wire 0.3^{mm} in diameter. In the core of the primary, which was 35.5^{cm} long and 3.5^{cm} in diameter, there were nearly a thousand soft iron wires carefully annealed and insulated with shellac. As a result of having such large wire for its secondary, the current was very large, and the potential as determined by the length of the spark was in the neighborhood of 120,000 volts. The current was supplied to the coil by a Siemens alternating current dynamo of about five horse power which was driven by a gas engine, and whose magnets were excited by a small dynamo using approximately three horse power.

With the terminals arranged horizontally the discharge was exceedingly intense and vigorous, being accompanied with a loud singing noise. It consisted of a light nebulous flame of a whitish color, with a slight tinge of yellow or green, rising gradually from the terminals and meeting at the center, where the color changes to a reddish. The flame appeared to the eye to be continuous, but, when observed in a rotating mirror or photographed on a swiftly moving plate, the alternate discharges were plainly discriminated. About and close to the terminals the bluish-purple flame, caused by the nitrogen of the air was plainly seen. The spark would leap across an interval of about 3.5^{cm}, and when the discharge was once started, the terminals could be drawn apart for as much as 20^{cm}

* Phil. Mag., Nov. 1879.

† Vol. xxx, p. 173.

or 25^{cm} without extinguishing the flame, presenting a striking and beautiful spectacle.

It may be of interest here, in view of the peculiar character of the discharge, to give the results of some experiments which were made a few years ago in this laboratory to determine the time and mode of its formation. A camera was arranged so that the discharge, just as it was forming, could be photographed upon a rapidly moving plate. At the same time the image of a spark from a tuning fork whose point dipped in mercury was adjusted so as to fall upon the plate side by side with that of the discharge. The photographs show that the spark passes directly across at first. As each spark has a tendency to follow its predecessor and the air becomes heated causing an upward current, the path of the discharge rises upward little by little until it reaches its permanent condition. From the period of the tuning fork it was calculated that about one-tenth of a second was required for this.

In the *Chemical News** Crookes has an article on this flame in which he states that it consists chiefly of nitrogen burning with the formation of nitrous and nitric acids, and that it shows no lines, but that the spectrum is faint and continuous. It is more probable though that the conditions here are similar to those in a tube from which a portion of the air has been exhausted. Owing to the heat, the air within the aureola becomes rarified and partially conducting. The luminosity is caused by the air being heated and electrified. Stratifications can be seen and photographs show them distinctly somewhat as they are shown in a vacuum tube.

An examination of the spectrum with terminals of several different metals, made by means of an ordinary prism spectroscope, shows in all cases, and as the most prominent feature, a continuous background which is very bright in the red, yellow, and green, but gradually decreases in intensity until it fades away in the violet. The yellow sodium lines are always present, due to particles in the air or impurities of the electrodes. Generally a few of the stronger lines, which are due to the metal of the electrodes and are ordinarily seen in its flame spectrum, appear and others which come out only occasionally. With zinc terminals and also with those of aluminum, the flame is yellowish in color but has a peculiar bluish-green core which is very intense, extending in streaks throughout the flame. The discharge from electrodes of soft iron which are small in diameter presents a beautiful spectacle, inasmuch as the iron, because of its large resistance, becomes highly incandescent, and bursts into a brilliant combustion, throwing off luminous particles in all directions. A banded structure from about wave length

* June 17, 1892.

4247 to about wave length 4225 came out which appeared to be the same in the case of all the metals employed. When the coatings of a large Leyden jar were connected to the terminals of the secondary, the discharge took the form of intensely brilliant sparks following one another in such rapid succession and such energetic detonation as to cause a jagged and almost deafening roar. In general the spectra of the metals employed in the induction flame are less complete and less developed than their flame spectra, owing to the fact that they are obscured by the rather intense continuous spectrum.

For a more careful study of the spectrum than the one previously described, which was made with the naked eye, it was necessary to have recourse to photography. To obtain the photograph of this discharge a Rowland concave grating having a radius of 21.5 feet was employed. The upper half of the photographic plate was exposed to the spectrum of the sun's rays for a comparison and the lower half to that of the flame between the terminals of the metal to be studied.

The plate upon which was the spectrum which it was the primary purpose of this investigation to locate, was stained with erythrosine to make it more sensitive to the rays at the red end of the spectrum. This staining also appears to increase the sensitiveness of the plate for ultra-violet rays. These lines are in the region where the red of the first spectrum and the ultra-violet of the second overlap, and they begin abruptly at wave length 6127.32 in the red and extend down to 6269.09, or at 3063.66 in the ultra-violet, extending down to 3134.55. Inasmuch as the two spectra overlap, it was uncertain to which spectrum they belonged.

The first thing that suggested itself was that these might be due to copper from the electrodes. Very few copper lines so far down in the red are given in the very admirable tables of the British Association Report.* This fact renders it impossible to make a comparison of any significance with the lines given in this region. The number of copper lines given in the ultra-violet was much larger, but still so much smaller than the number of lines upon the plate that no comparison of any value could be made although there were a few cases of approximate coincidence.

With a view to ascertain to which spectrum the lines belonged various devices were employed. At first plates stained with cyanine were tried, and some preliminary experiments made in obtaining the solar spectrum to get the time of exposure. It was found that an exposure of eighteen minutes gave a good spectrum extending into the red far beyond the situation of the lines in question. Several plates were then exposed to the

* 1884, p. 384.

discharge for an hour and a half to secure the lines, but, as no lines were obtained, and none of the ultra-violet lines of the solar spectrum were visible, it was suspected that the staining with cyanine, while it made the plate more sensitive to the red rays, diminished the sensibility to the ultra-violet, and therefore, that probably the lines sought were in the ultra-violet.

Plates stained with erythrosine were next tried. It was found that an exposure of five minutes gave the ultra-violet spectrum of the sun's rays together with the lines in the red, in the neighborhood of the lines sought for. To obtain the lines several exposures to the discharge of an hour and a half were made and a few feeble lines obtained. The time of exposure was then increased to two hours. Upon development the lines upon the first plate tried were sharp and distinct. The wave lengths were calculated as accurately as possible by means of the comparison solar spectrum and Rowland's charts. This is first done on the supposition that they are in the lower part of the first spectrum and the result divided by two to get their true wave length in the ultra-violet of the second spectrum, since it was now regarded as almost certain that they were ultra-violet lines owing to the fact that we did not obtain them with plates stained with cyanine, which makes them more sensitive to the red rays, and on the contrary did obtain them when the plates were stained with erythrosine, which increases their sensitiveness to the ultra-violet, as was proven by exposing a dry unstained plate to the sun's rays when, although the ultra-violet lines were visible, they were exceedingly faint.

The wave lengths as calculated by means of Rowland's charts of the solar spectrum and the comparison on the plate are as follows:

3063·66	3086·48	3105·71
3063·83	3087·40	3106·02
3064·30	3089·80	3106·55
3065·04	3089·94	3109·46
3065·17	3090·24	3110·30
3066·27	3091·35	3112·17
3068·00	3091·48	3113·43
3068·31	3092·45	3114·85
3069·11	3092·84	3115·49
3070·02		
3070·52	3094·70	3117·87
3070·83	3095·41	3118·03
3072·05	3096·16	3122·70
3078·47	3096·87	3124·14
3080·06	3098·63	3130·46
3080·27	3099·53	3134·55
3081·65	3101·20	
3083·35	3102·13	
3085·25	3102·35	

In the next experiment platinum electrodes were used in order to determine whether the lines were due to copper or to the gases through which the discharge passed. This plate upon development showed exactly the same series of sharp lines. Hence they must be due to some one of the gases, or the oxides of them, which occupy the intra-polar space.

To settle the location of the lines conclusively the camera was adjusted so as to include the region in the first spectrum in which they were supposed to be. An ordinary dry plate without staining was used and an exposure of an hour given it. After the development of the plate the lines sought were seen sharp and clear, which proved conclusively that they were in the ultra-violet of the first spectrum.

The work of ascertaining to what one of the intra-polar gases, or oxides of them, the lines belonged, was next taken up. A careful comparison of the recorded lines of the hydrogen spectrum did not reveal any coincidence. In the Report* of the British Association for the Advancement of Science some lines due to water vapor are given, and a comparison with the lines studied in this investigation showed that a large number of them were apparently in exact coincidence.

These lines were discovered by W. Huggins† and also by G. D. Liveing and J. Dewar‡ at almost the same time. Huggins exposed a photographic plate to the flame of hydrogen burning in air for one minute and a half and was very much surprised upon developing it to find such a strong group of lines. He traced the lines in this group from wave lengths 3062 to about 3290, the upper limit of which is about the same as that of the lines studied here and the lower limit considerably below. Upon placing a spirit lamp before the slit of the spectroscope the spectrum is essentially the same, but, as it is less intense, only the strongest lines are seen.

In their article Liveing and Dewar give the results of the study of some lines which they had obtained and noted in the spectrum of coal gas burning in oxygen when investigating the spectrum of "Compounds of Carbon with Hydrogen and Nitrogen." The group of lines which they obtained extends from wave lengths 3062 to about 3210. The same spectrum was given by the electric spark taken, without condenser, in moist hydrogen, oxygen, nitrogen, and carbonic acid gas, but it disappeared if the gas and apparatus were thoroughly dried. Hence they were led to the conclusion that the spectrum was that of water. In conclusion they were not prepared to guarantee that oxides of nitrogen from traces of air might not have something to do with some parts of the spectrum here observed.

* 1886, p. 169.

† Proc. Roy. Soc., vol. xxx, p. 576.

‡ Proc. Roy. Soc., vol. xxx, p. 580.

In a second* communication to the Royal Society, "On the Spectrum of Water," Liveing and Dewar state that the spectrum which they had figured in the article just mentioned did not by any means exhaust the spectra of flames observed by them, but that it was as much as they were able at that time to trace to water as its cause. In a third† article they give the results of a very searching investigation of the spectrum of the oxy-hydrogen flame. By making long exposures they obtained photographs of the oxy-hydrogen flame, showing closely set lines from wave lengths 2268 to 4100, with traces of lines beyond those limits. The whole spectrum appeared to consist of a rythmical series of lines, the strongest of these series being the one first described.

Liveing and Dewar refer to an article‡ by M. Deslandres in which he states that the first band of the water spectrum (i. e. the group beginning at wave length about 3063) includes a series of rays which reproduce, line for line, at the same distance and with the same relative intensities, the band A of the solar spectrum; and that the second band (i. e. the group beginning at a wave length about 2811) includes a series corresponding to B, and that in the third α may be found to be reproduced. Liveing and Dewar were not able to make out such an exact correspondence between the lines of the water spectrum and those of A, B, and α as M. Deslandres' words seem to imply, but nevertheless the similarity of the grouping was very remarkable.

To study further the question whether these lines were due to water vapor, or to the effect of water vapor upon the gases occupying the intra-polar space, a plate was exposed to the discharge when it took place under special conditions, namely that the upper half of the plate should be exposed to the discharge when it took place in ordinary air and the lower half of the plate to it when it took place in air containing a large amount of moisture. For the purpose of supplying a large amount of water vapor to the air about the discharge during the exposure of the lower half of the plate, water was boiled in a glass flask, containing a cork stopper through which passed a glass tube so shaped that by its means the issuing jet of steam could be easily directed into the flame.

In this experiment the upper half of the plate was exposed for forty-five minutes to the discharge in ordinary air, and the lower half for the same length of time when steam was supplied to it. In the latter case the time during which the light actually fell upon the slit of the spectroscope was not really as

* Proc. Roy. Soc., vol. xxxiii, p. 274.

† Trans. Roy. Soc., vol. clxxix (A), p. 27.

‡ Comptes Rendus, vol. c, p. 854.

great as in the first case owing to the fact that the flame was somewhat disturbed by the jet of steam. Nevertheless, when the plate was developed, the lines upon the lower half came out much more strongly than upon the upper, the only difference being in the intensity, which shows that if the lines are not directly due to water vapor, the latter greatly facilitates the development of lines due to the several gases of the air, or combinations of these gases, probably both.

Tables of wave lengths of the different constituents of the atmosphere were next examined to see if any of the lines given coincided with the lines studied. In a note* regarding a very careful search which he made for the line spectrum of hydrogen in the oxy-hydrogen flame, Liveing states that he failed to find the slightest trace of any one of the hydrogen lines. As oxygen is a very large constituent of the air, it was very important to make a comparison of the lines due to it, which were catalogued, with these lines. There were found, however, to be no coincidences, which indicates that none of the lines are due to oxygen.

Just before the completion of this work an article by G. Berndt appeared.† While studying the spectra of several metals, Berndt had noticed in all of them a banded spectrum extending from wave lengths 5100 to 2000, a portion of which covers the region in which the banded structure previously described was located. He concluded from his observations that the banded structure in the visible portion of the spectrum of different metals is dependent upon the presence of oxygen and also suggested that the banded spectrum in the ultra-violet is due to air. At the close of his article Berndt publishes a list of nitrogen lines obtained by an induction discharge in nitrogen free from oxygen. Upon comparing them with the lines studied in this investigation, a number of apparent coincidences were seen, making it probable that some of these lines at least were due to nitrogen.

The last experiments made were a continuation of the attempt to ascertain if possible to which one of the intra-polar gases the lines belonged. As the solar light in this region is very feeble, the light from a voltaic carbon arc was passed through bulbs containing nitrogen tetroxide, and an attempt made to secure the absorption lines due to it. The lower half of the photographic plate was exposed to the light which passed through the nitrogen tetroxide and the upper half to the light from the discharge alone to see if any of the lines coincided with the absorption lines due to the nitrogen tetroxide. Although several exposures of nearly two hours were

* *Phil. Mag.*, vol. xxxiv, p. 371.

† *Drude's Annalen der Physik*, No. 4, p. 788, 1901.

made to get the absorption spectrum, the lines obtained were so feeble and so few in number that it was impossible to make a comparison of any significance in determining the coincidences with the lines investigated.

After considering the large amount of work done in the past in studying this strongest group of the so-called water spectrum and also the work done in this investigation, it seems hardly possible that the lines are due to water vapor alone, but rather that they are due to the various constituent gases of the air and combinations of them which are facilitated by the presence of water vapor. On the whole, owing to the small amount of water vapor in the air, the experiments seem to point to the conclusion that the lines of this group are due for the most part to the nitrogen of the air and its oxides.

Sloane Physical Laboratory, June 11, 1901.

SCIENTIFIC INTELLIGENCE.

I. CHEMISTRY AND PHYSICS.

1. *The Ignition-temperature of Phosphorus.*—The temperatures given in chemical literature as the point at which phosphorus takes fire in the air or in oxygen vary from 38.1 to 75°. The amount of moisture present in the air or oxygen probably has a great effect upon this temperature, as it is well known that phosphorus may be distilled in perfectly dry oxygen without ignition. F. H. EYDMAN, JR. has now made a careful series of experiments with air, oxygen, and air diluted with an equal volume of carbon dioxide. These gases were used in a moist condition, in fact they were made to bubble through molten phosphorus which was under water in a test-tube. The test-tube, which contained a thermometer, was placed in a flask of water, and the latter was gradually heated until the phosphorus was ignited by the gas which bubbled through. With air the observed temperatures of ignition varied from 44.9 to 45.4°, with an average of 45°; with oxygen the mean of four closely agreeing results was 45.2; while with the mixture of air and carbon dioxide two experiments gave 45° in each case. The interesting conclusion is reached that the ignition-point of phosphorus does not vary with the concentration of the oxygen. The author intends to extend his experiments by using dry air and oxygen.—*Recueil Trav. Chim. Pays-Bas*, xix, 401. H. L. W.

2. *The Composition of "Caro's Acid."*—BAEYER and VILLIGER have made an investigation of this powerfully oxidizing acid, which is prepared either by treating a persulphate with concentrated sulphuric acid, by the electrolysis of rather concen-

trated sulphuric acid, or by the action of concentrated sulphuric acid on hydrogen peroxide. These chemists were unable to obtain the acid in a pure state or to prepare any salts of it, but by studying the behavior of hydrogen peroxide, Caro's acid, and persulphuric acid they found that the first substance could be determined and destroyed in the presence of the others by means of potassium permanganate, and that Caro's acid liberates iodine immediately from acidified potassium iodide solution, while with persulphuric acid this liberation is very slow. By applying these facts they were able to determine the ratio of the oxygen to the sulphuric acid liberated by the acid under investigation, and the conclusion was reached that it has the composition represented by the formula H_2SO_5 . The probable structure of the acid is

$\begin{array}{c} H-O \\ | \\ HO-O \end{array} > SO_2$. The change from persulphuric acid to Caro's acid, which takes place gradually in solution, is as follows :

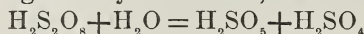

Caro's acid is then gradually changed in solution to sulphuric acid and hydrogen peroxide according to the equation,

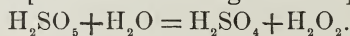

In the presence of strong sulphuric acid the last equation is reversed to a certain extent, but the product still contains much unchanged hydrogen peroxide.—*Berichte*, xxxiv, 853. H. L. W.

3. *Vitrified Quartz*.—In a recent discourse delivered before the members of the Royal Institution in London, W. A. SHENSTONE exhibited the production of tubes and bulbs of fused silica. The first stage of the process consists in getting quartz into a condition in which it will not fly to pieces when heated. This is done by heating it in small fragments to about 1000° and throwing it quickly into cold water. It then becomes white and enamel-like, and after the treatment has been repeated it may be thrust suddenly into the hottest part of an oxyhydrogen flame without splintering to the slightest extent. Silica becomes hot enough to be worked only above the melting-point of platinum, and it is only the hottest part of the oxyhydrogen flame, just beyond the inner blue cone, where the temperature is sufficient for the purpose. To produce tubes and other vessels from the enamel-like silica, two fragments of it held in platinum forceps are heated and pressed together until they adhere, then other lumps are added, one at a time, until a rough rod is produced. This rod is afterwards reheated and drawn out into a finer rod about 1^{mm} in diameter. Some of these fine rods are then bound round a stout platinum wire, while soft, and heated until their sides adhere. The rough tube thus made is reheated, drawn out and, after being closed at one end, a bulb is blown in it. By applying thin rings of silica to the small bulb, heating until the silica begins to spread and blowing out, it is increased in size, and by drawing out such bulbs long tubes may be prepared. When a silica tube has been produced it may be worked in the flame as easily, though not as

inexpensively, as glass. It may be thickened by adding fresh rings of silica, and all kinds of joints can be easily made. In one respect silica is easier to work than glass. It never breaks when suddenly thrust into the flame, and the finished apparatus needs no annealing. For this work the eyes must be protected by very dark glasses.

Vitrified quartz is harder than feldspar, but less hard than chalcedony. When cut with a file it breaks like glass. Its conducting power for heat is about equal to that of glass. Its density, 2.21, is much lower than that of quartz, 2.66. It has been found that the coefficient of expansion by heat is only $\frac{1}{17}$ as great as that of platinum, and much smaller than that of any similar substance that has hitherto been studied. The substance is shown to be remarkably transparent to ultra-violet rays, hence its application to spectroscopic work will probably be important. Perhaps the most remarkable property of vitrified silica is its resistance to sudden changes of temperature. Water may be dropped upon a white hot rod of the substance, or a similarly heated tube of it may be plunged into cold water or even into liquid air without injury. It is suggested that the material will be useful in the preparation of thermometers, for instance, those in which tin is used in the place of mercury, and also for the bulbs of air-thermometers. The interesting observation has already been made that when oxygen and nitrogen (air) are heated above the melting-point of platinum in a silica tube, nitrogen peroxide is produced.—*Chem. News*, lxxxiii, 205. H. L. W.

4. *Influence of Magnetism upon Supersaturated Solutions.*—Attempts by A. DE HEMPTINNE to produce the crystallization of supersaturated solutions and supercooled fusions by exposure to a strong magnetic field were in every case failures. By indirect means it was shown that crystalline substances in saturated solution showed a distinct orientation in this field; hence it is concluded that crystallization in these cases does not depend upon the orientation of the molecules.—*Zeitschr. physikal. Chem.*, xxxvii, 223. H. L. W.

5. *The Preparation and Properties of Ammonium Cyanate.*—This salt was not obtained as a solid in a pure condition by Liebig and Wöhler, on account of its transformation into urea. WALKER and WOOD have recently succeeded in preparing this famous salt by mixing solutions of cyanic acid and ether at -17° , and also by mixing the gases diluted by air. It is a colorless salt which is readily soluble in water, and this solution gives the reactions for the cyanate and ammonium ions. Upon heating it fuses at 80° , but then becomes solid again, being changed to urea.—*Jour. Chem. Soc.*, lxxvii, 21. H. L. W.

6. *Detection of Selenium in Sulphuric Acid.*—It has been found by JOUVE that crude acetylene gas furnishes a very delicate test for selenium in sulphuric acid by precipitating it in the elementary condition. He states that a red coloration can be observed when the acid contains only one part of selenium in 100,000, while

the test with sulphurous acid is only about one-tenth as delicate. The sensitiveness of the reaction is increased, as far as the rapidity of the coloration is concerned, if the acetylene contains hydrochloric acid fumes.—*Chem. News*, lxxxiii, 243. H. L. W.

7. *Qualitative Chemical Analysis, Organic and Inorganic*; by F. MOLLWO PERKIN. 8vo, pp. viii, 266. London, 1901 (Longmans, Green & Co.).—This is an elementary text-book that is unusually full in respect to the explanations and chemical equations that are given, and good judgment has been used in the selection of the analytical methods that are employed. The book presents a novel feature in including a treatment not only of the more common organic acids, but also a variety of other organic substances, such as aldehydes, alcohols, acetone, glycerol, several sugars, starch, a few bases and glucosides, and about a dozen of the more important alkaloids. H. L. W.

8. *Viscosity of Argon*.—Lord Rayleigh obtained the value 1.21 for the frictional coefficient of argon at ordinary temperature. HUGO SCHULTZE, thinking that the apparatus employed by Lord Rayleigh was not suitable for obtaining extreme accuracy, has made new determinations. Extraordinary care was taken in cleaning the glass of the apparatus and in purifying the argon. It was possible to force the argon back and forth through the glass tubes, and to measure the time of flow with accuracy. The gas was also heated in a well devised calorimeter and a much improved manometer of water in combination with mercury was employed. The relative value obtained by the author is a little larger than that obtained by Rayleigh. Tables are given of the relative values of the coefficient with reference to air. The temperatures varied from 15° C. to 183° C.—*Ann. der Physik*, No. 5, pp. 140-165. J. T.

9. *Conductivity produced in Hydrogen and Carbonic Acid Gas by the Motion of Negatively Charged Ions*.—This subject has been studied by Professor TOWNSEND and Mr. P. J. KIRKBY by the aid of the Röntgen rays, which were allowed to fall on the gases contained between two parallel plates—maintained at various differences of potential. The authors conclude that a negative ion makes 11.5 collisions per centimeter in hydrogen at 1^{mm} pressure, and 29 collisions per centimeter in carbonic acid gas at the same pressure. It was found that the mean free path of an ion is longer than the mean free path of a molecule in the following ratios:

4.8 : 1 in hydrogen.

4.6 : 1 in carbonic acid gas.

4.3 : 1 in air.

—*Phil. Mag.*, June, 1901, pp. 630-642. J. T.

10. *Electromotive Force of the Clark- and the Weston-Cell*.—An exhaustive examination of the constancy of the electromotive force of these elements has been made at the Reichsanstalt, by W. JAEGER and S. R. LINDECK. This result of their work shows that the criticisms of Cohen, in regard to an instability of

cadmium sulphate and cadmium amalgam in the proportions employed in the cells used at the Reichsanstalt, are not well founded, at least when the thirteen and twelve per cent amalgam is employed.—*Ann. der Physik*, No. 5, pp. 1-50. J. T.

11. *Electrical Flow in Gases*.—L. STARK gives a theoretical discussion of this subject in which he shows under what conditions Ohm's law does not apply to electrical discharges in Plucker tables. The streaming and the phenomena of stratification depend upon the rate of arrival and departure of ions—also upon the amount of ionization and mobilization. Ohm's law holds for that portion of the discharge in which the ionization remains constant. In general there are only portions where this is true. In the neighborhood of the electrodes on account of the transport of free ions by the streaming the ionization is lowered. This happens especially at the cathode. In metallic conductors the force lines coincide with the stream lines. This is not true in the case of electrical discharges in gases. The author discusses also the inner electromotive force developed in electrical discharges. He also takes issue with Professor J. J. Thomson theory of stratification.—*Ann. der Physik*, pp. 89-112, No. 5, 1901. J. T.

12. *A Treatise on Electro-Magnetic Phenomena and on the Compass and its Deviations aboard Ship; mathematical, theoretical, and practical*; by Commander T. A. LYONS, U. S. Navy. Volume I, pp. xv and 556. New York, 1901 (John Wiley & Sons).—The author has undertaken the preparation of an exhaustive treatise upon the use of the magnetic needle on ship-board. This is a subject of the greatest importance as well as of very general interest, and one which it is difficult to find adequately treated in any single volume. We have before us the discussion of the physical subjects which form the basis of the practical discussion which is to follow. In order to bring out clearly the nature of the periodic changes that take place in the earth's magnetism, as well as the complex relations of magnetism and electricity in general to the ether, the author has begun with the foundation subjects and treats them in a familiar and popular way, so as to be intelligible to one whose studies have not been definitely along this line. For example, he treats of wave motion generally, from the sound wave to those of Hertz, and in the part of the volume following, discusses not only the magnetism of the earth, and the methods of determining magnetic elements, but also the phenomena of magnets and magnetic fields in general. The second volume, which is to contain the discussion proper, will be awaited with interest.

II. GEOLOGY AND NATURAL HISTORY.

1. *The Eocene Deposits of Maryland*, by WILLIAM BULLOCK CLARK and GEORGE CURTIS MARTIN, pp. 1-92; and *Systematic Paleontology*, by MESSRS. CASE, EASTMAN, ULRICH, CLARK, MARTIN, VAUGHAN, BAGG, HOLLICK. Pp. 93-331, Plates L-LXIV. *Mary-*

land Geological Survey. Baltimore, 1901.—The authors of the first paper have drawn the distinction between stratigraphic and paleontologic units; but as they state, “the former are designated as formations and members, the latter as stages and substages. As their limits are the same the same name is employed for each.” Names are given in the following table:

Group.	Formations or stages.	Members or substages.
Pamunkey.	{ Nanjemoy	{ Woodstock
		{ Potapaco
	{ Aquia.	{ Paspotansa { Piscataway.

The several members or substages are still further divided into zones from which the faunules are obtained which are listed.

The zones are apparently discriminated on a lithologic basis and grouped together on a paleontologic basis into members. The details are carefully worked out and the results are well arranged. The only criticism the writer would suggest is that the discrimination between formation and fauna is not carried far enough to exhibit the full value of the fossils in correlation.

If the combination of species, called substages, is supposed to be restricted to the formational divisions, called members, then the paleontological statistics may serve to identify the members; but if the species instead of stopping their existence migrated at the end of each member, the true value of the species in correlation is not reached by applying the same name to the formational members and to the faunal substages.

The paleontological part has been (as it should be) assigned to specialists. The whole fully keeps up the reputation these reports have held from the beginning of the new administration.

H. S. W.

2. *Annual Report of the Geological Survey of Arkansas for 1892.* Vol. V. The Zinc and Lead Region of North Arkansas; by JOHN C. BRANNER, State Geologist. Pp. 1-395, plates 1-38, and figs. 1-92. Little Rock, 1901.—An appropriation made by the Arkansas legislature in 1899 provided for the publication of this volume, the investigation for which was completed before the official termination of the Survey in 1893.

The chief part of the volume is concerning the zinc and lead deposits of northern Arkansas. These ores were originally deposited in sedimentary beds of the Ordovician age, and by infiltrating waters were carried through fissures to form secondary deposits in cavities in rocks of later age.

The Paleozoic faunas of northern Arkansas, Chapter vii, pp. 268-362, by Henry S. Williams, is here published for the first time. The report was prepared during the progress of the Survey, its detention having been caused by lack of appropriations for its publication. The report contains a classification of the Paleozoic formations of the northern part of the State, with lists of the contained faunas, and discussion of several complex strati-

graphic problems, one of which concerns the geological horizon of the manganese deposits.

H. S. W.

3. *Summary Report on the operations of the Geological Survey of Canada for the year 1900*; by GEORGE M. DAWSON, Deputy and Director. Pp. 1-203. Ottawa, 1901.—This last report of the late director, issued after his death, exhibits the customary energy and progress of the Survey in developing the geological resources of the Dominion.

The commercial value of mica and molybdenite has led to their special examination by experts. The mica (phlogopite) of Quebec and Ontario is of special value for electrical purposes; but the most satisfactory market is shown to be the United States and not Great Britain. Molybdenite samples subjected to critical test show that cobbing and hand-picking may be carried on with the ordinary ores profitably, but when the ore is of low grade, rolling, screening and jigging are not economically successful.

Salt is reported from the "Medina formation" in a well near St. Grégoire, Beauce Co., Quebec.

The Crows Nest coal field is estimated to contain 22 billion tons of possibly workable coal. The coal is of Cretaceous age, and has excellent coking qualities with small percentage of ash. A similar Cretaceous coal area has been discovered between the 55th and 57th parallels of latitude in British Columbia; and anthracite has been found in the region of the head waters of the Skeena and Stikine Rivers. The fuel near Forty Mile Creek on the Yukon is Tertiary lignite, but samples of anthracite are reported from a locality west of Lake Marsh.

Study of the formations of the Brockville map-sheet (Ontario) has revealed the fact that fossils referred to in earlier reports as obtained from beds of Potsdam age, are found in what are known as transition beds between the sandstone and the limestone. The best specimens were obtained "from weathered surfaces of a siliceous limestone which represents the base of the Calciferous formation."

Investigations in the Cambro-Silurian slate region of York and Carleton Counties, New Brunswick, have developed the fact that the fossiliferous Silurian rocks overlie discordantly the Cambro-Silurian slates; and Cambrian fossils have been found in black shales near Benton, Carlton Co., belonging apparently to the lower series. Nevertheless a satisfactory solution of the difficult stratigraphical problem is not yet reached.

The Arisaig formations have received special study with the result of their reduction to four divisions, to which the names Stonehouse, Moydart, McAdam and Arisaig formations are applied.

H. S. W.

4. *A revision of the genera and species of Canadian Paleozoic Corals—the Madrepোরaria aporosa and the Madrepোরaria rugosa*; by LAWRENCE M. LAMBE. *Geological Survey of Canada*. Contributions to Canadian Paleontology, Vol. IV, Part II, pp. 97-197,

plates VI-XVIII. Ottawa, 1901.—The paleontologic and literary part of this report leave nothing to be desired, and the drawings are admirable portrayals of the characteristics of the species drawn by the author and thus having all the value of scientific definition. A few notes regarding correlation are of importance. It is suggested by Dr. Whiteaves that "American stringocephalus zone" be applied to the Manitoba horizon to avoid confusion with the European zone of that genus (p. 104). Attention is called (p. 124) to Billings' identification of the Gaspé limestone, No. 8 of Indian Cove, Gaspé, "as nearly of the age of the Oriskany sandstone." The application of "Lower Helderberg" to the fauna of L'Anse à la Barbe, Baie des Chaleurs, Que., is commented on; the opinion of Dr. Whiteaves cited that the limestone seems to be most nearly equivalent to the Guelph formation of Ontario, Ohio and Wisconsin (see foot-note, p. 129), and the remark is made that the term Lower Helderberg has been used in part I of this volume, "in a sense as comprehensive as that evidently implied by the term in the 'Geology of Canada.'" This comprehensive use of the term should be considered in reading the review of the writer on the first volume. (See this Journal, ix, p. 155, 1900.)

H. S. W.

5. *The structural relations of the Amygdaloidal Melaphyre in Brookline, Newton and Brighton, Mass.*; by HENRY T. BURR. Bull. Mus. Comp. Zool. at Harvard College, Vol. 38, Geol. series, Vol. V, No. 2.—This paper once more brings to our notice the dispute regarding the structural relations of the melaphyres of the Boston Basin and the associated sedimentary rocks. Mr. Burr concludes, from observations made in the field, that, for the area studied, the beds of melaphyre are strictly intrusive in character; and in so doing he takes very decided and pointed exception to the views of Prof. W. O. Crosby, who, as is well known, considers the main beds, at least, to be unquestionably contemporaneous flows. The facts upon which Mr. Burr bases his main conclusions are: "1. The conglomerate associated with the melaphyre contains no fragments of it. 2. The contacts, wherever found, are igneous in character. 3. The melaphyre is seen in contact with sediments varying from the coarsest of the conglomerate to the finest of the slate. 4. The distribution of the melaphyre shows it to be discordant with the structure of the sediments under any interpretation of the latter that has been offered." In the May number of the American Geologist, Prof. Crosby has taken occasion to call into question some of Mr. Burr's statements and conclusions and to present again the arguments in favor of the contemporaneous character of the melaphyre. He calls attention to the fact that, contrary to Mr. Burr's statement, fragments of melaphyre *are* found in the overlying conglomerate; and shows, we think, very clearly, that, so far as the character of the contacts and the other relations to the associated sedimentaries are concerned, the melaphyres are as well considered contemporaneous as intrusive sheets. He points out that the main melaphyre

beds have all the characteristics of lava flows, and raises the very pertinent question why, if, as is claimed, the melaphyre and trap dikes of the region are petrographically hardly distinguishable rocks, we find a huge dike of melaphyre amygdaloidal and scoriaceous in texture, while a three-foot dike of trap is a dense, holocrystalline rock. Attention is also called to the significant presence of well defined beds of tuff, a fact entirely overlooked by Mr. Burr. In the light of these and other facts brought out by Prof. Crosby it would seem, even to the casual reader, that the weight of evidence is overwhelmingly in favor of a contemporaneous origin and that Mr. Burr's paper is thus the unintentional cause of strengthening an exactly opposite conclusion from the one given in the paper itself.

In view of the fact that Prof. Crosby had, some twenty years ago, fully described the "new interpretation" of the structural relations of the Chestnut Hill slates to the northern conglomerate, now presented by Mr. Burr, the word "new" seems, to say the least, rather superfluous.

C. H. W.

6. *Sul Periodo di forte Attivita esplosiva offerto nei mesi Aprile-Maggio 1900 dal Vesuvio*; par R. V. MATTEUCCI. Boll della Soc. Sism. Ital., Vol. vi, 8°, 110 pp., 6 pl., 1901.—This volume gives a detailed account of the phenomena and products attending the period of explosive activity of Vesuvius at the time mentioned. The author begins with a general description of the phenomena of the explosions, discusses their frequency and describes their effects on the crater, etc. He then discusses the material ejected, the powder and sands, the lapilli, scoria, bombs and solid blocks, each of which is made the object of particular study. An immense quantity of these blocks were ejected, a photograph being given of one containing twelve cubic meters of material. Chemical determinations show that the ejected matter was somewhat lower in silica than previous effusions of the volcano. Some calculations of the force involved in projecting the large block mentioned above are also given, showing that it reached an altitude of about 300 meters. The work closes with a discussion of volcanic explosions, both former ones of Vesuvius and of other volcanoes as well.

The plates are very beautiful and interesting heliotype reproductions of instantaneous photographs, showing the form and development of the smoke cloud from the great vapor puffs in different stages and the swarm of projected blocks in mid-air. The work as a whole is an excellent contribution to the study of volcanic outbreaks in general and to the history of Vesuvius in particular.

L. V. P.

7. *Der Vulcan Etinde in Kamerun und seine Gesteine*; von E. Esch. Sitzber. d. k. preuss. Akad. d. Wiss. zu Berlin, phys. mat. Classe 1901, XII and XVIII, pp. 41, figs. 22.—Etinde is one of the smaller volcanos of the Cameroon Mts., a volcanic group covering some 150 square kilometers, close on the coast of western Central Africa, and whose highest peak attains an altitude of

13,700 feet. The volcano is greatly eroded and is one of the oldest of the group. Its age cannot be exactly told, but the tuffs and ashes of the group cover sediments of Upper Cretaceous age and contain plant remains representing the present flora.

The chief interest lies in the igneous rocks which form the lavas of the mountain. They are of highly alkaline types, and among them are represented leucite with phenocrysts of nephelinite, hauynite and augite, occasional pyrite and perovskite in a groundmass of leucite, nephelinite and augite, with some apatite

	SiO ₂	Al ₂ O ₃	Fe ₂ O ₃	FeO	MnO	MgO	CaO	Na ₂ O	K ₂ O	H ₂ O	P ₂ O ₅	TiO ₂	SO ₃	Cl	CO ₂
1	46.48	19.00	4.74	2.30	tr.	2.49	4.35	8.46	6.78	3.31	.15	1.22	.19	.08	.36= 99.91
2	40.10	15.27	10.13	1.85	.08	4.59	12.08	4.78	3.34	2.93	.87	3.64	—	—	.23= 99.89
3	39.97	17.30	7.41	3.05	.09	3.82	10.53	5.14	3.56	4.11	.84	3.34	.06	.14	.33= 99.89
4	39.30	13.66	7.42	4.45	.08	4.46	11.37	5.78	1.44	4.53	.85	3.62	2.17	.48	.15= 99.76
5	39.37	16.50	2.28	7.97	.06	4.48	10.22	4.73	3.38	4.77	.13	3.31	2.14	.09	.64=100.07
6	38.39	12.64	7.40	6.15	.02	6.46	14.17	4.35	2.44	1.62	1.16	4.44	.47	.37	.23=100.31
7	40.15	17.32	7.25	4.00	.08	4.43	11.78	5.99	3.78	1.18	.71	3.21	—	—	.15=100.38

1, Leucite; 2, Leucite nephelinite; 3, Leucite nephelinite, including ZrO₂=.20; 4, Hauynophyre; 5, Hauynophyre; 6, Nephelinite. of a special variety; 7, Normal nephelinite, including ZrO₂=.35. All analyzed by Dr. Max Dittrich.

and perovskite. Leucite composes about one-half the rock. Leucite nephelinite also occurs, composed of augite, apatite and ores in a groundmass of augite, leucite and nephelinite, the latter predominating. Hauynophyres occur containing phenocrysts of hauynite, augite and ore grains in a groundmass much like those just mentioned. A nephelinite of a special variety in which the nephelinite in the groundmass is not fully individualized is also described. Phenocrysts of augite, hauynite, apatite and titanite lie in a clear colorless base with microlites of augites and ore grains. The colorless base is held to be partly individualized nephelinite. Nephelinites of normal type are also described and the twinning and optical properties of the larger individuals is made a special study. The accompanying table of analyses will be of interest to petrographers.

L. V. P.

8. *Søndre Helgeland* af J. H. L. VOGT. (Norges Geologiske Undersøgelse No. 29, 1900, Kristiania, 8°, 180 pp., 1 map, 21 figs.)—This work is devoted to an account of the geology of Helgeland, the southern part of the district of Nordland in northern Norway. With the exception of a small area of Archean the region is composed of metamorphic schists and limestones, probably of Cambrian-Silurian age. The author divides the metamorphosed sediments into mica schist, marble, and a later gneiss. In addition there are extensive areas of eruptive rocks consisting mainly of soda granite and gabbro. Sometimes these are strongly stretched and squeezed and are then held to have been injected previous to the final dynamic foldings which gave birth to the mountain chains; sometimes they are in normal condition and are then held to be of contemporaneous or later age.

A careful study of the morphology of the region is given by the author, the quaternary geology by him and REKSTAD, and the work is concluded with an account of the silver ore veins of Svenningdalen.

A résumé in German is given at the end. The work throughout is full of the suggestiveness in ideas and thoroughness in details that are characteristic of the author. L. V. P.

9. *Classification of Igneous Rocks.*—E. VON FEDEROV, in an article published in the Journal of the Mineralogical Society of St. Petersburg in 1900, page 395, gives a method for the classification of igneous rocks in which he endeavors to show that it is possible to divide all of the eruptive rocks into types and classes by assigning to them simple symbols like those used in crystallography.

In considering the general chemical composition of rocks in the order of the oxides, 1, R_2O ; 2, RO ; 3, R_2O_3 ; 4, RO_2 , it becomes evident that all of the ordinary rock-making minerals may be expressed by symbols of four numbers. Thus, quartz (0001), corundum, hematite, etc. (0010), spinel, magnetite (0120), olivine (0201), diopside and actinolite (0101), garnet (0323), biotite (1223), phlogopite (1313), anorthite (0122), orthoclase and albite (1013), leucite and aegirite (1012), nephelite (8089).

The reckoning of the different compositions is based on a regular tetrahedron whose summits are the points (1000), (0100), (0010), (0001); the center of the faces are the points (0111), (1011), (1101), and (1110); the center of the edges (1100), (1010), (1001), (0110), (0101), (0011), whilst the center of the tetrahedron is (1111).

Using these points the tetrahedron can be divided into 24 sphenoids, to whose centers there correspond 24 typical compositions. Of these fundamental types of chemical composition only four are represented, those having the symbols (1423), No. I, (1324) No. II, (1234) No. III, and (2134) No. IV. No. 1 is represented by the *periodotites*, No. 2 by rocks of the *gabbro* group, No. 3 by rocks of the *diorite* and *diabase* groups, and No. 4 by rocks of the *granite* and *syenite* groups.

The division of the types into classes is done by dividing the sphenoids into 24 sphenoids of the third order. By the aid of the principles of zonal crystallography the author explains the process to be followed to obtain the chemical composition when the indices corresponding to the third order are given, and how to determine if this composition is a *typical* one (represented by an interior point of the sphenoid), one *intermediate* between the classes, one of *transition* between the great types, or an *extreme* rock.

The author shows how these may be determined by graphic methods and makes a number of applications of his system. The main body of the text is in Russian, but a short résumé in French permits the salient features of the article to be understood by those who are not versed in that language. L. V. P.

10. *Boletín del Instituto Geológico de Mexico, Num. 13, Las Rhyolitas de Mexico.* Primera parte, por EZEQUIEL ORDEÑEZ, Mexico, 1900, 4°, 75 pp., 1 map.—This bulletin is the first of a series to be issued on the eruptive rocks of Mexico. The aim of the series is to make known the great number of varieties of rocks, their geographical distribution and field relations, their physiographic features, and economic importance as building material and soil. It is also expected to bring about uniformity in the petrographic nomenclature of Mexico. The first part of the bulletin is devoted to historical notes, principal subdivisions of the rhyolite family, macroscopic characters of the rhyolites and geographic distribution of the rhyolites in Mexico. The second and greater part is devoted to the description of various localities under the following four heads: (1) The "Bufas," (2) The Navajas, (3) Other regions of the Central Plateau, (4) The western Sierra Madre. The term "bufa," for many years applied by the miners in the region about Guanajuato and Zacatecas to curiously shaped masses of rock crowning the summits of prominent points, is adopted by the writer to designate these isolated erosion remnants of rock of a rhyolitic nature. The bulletin closes with a chapter upon the age of the rhyolites and a résumé in French.

Points of general interest are: the great distribution of the rhyolites, surpassed only by the andesites, in a belt reaching southward from the northern boundary of the country through the western Sierra Madre into the Central Plateau to the vicinity of the city of Mexico; the greater part of them were erupted from the end of the Miocene to the middle of the Pliocene. The succession of Tertiary eruptives, based on the evidence thus far presented, is: (1) Granites-Granulites, (2) Diorites-Diabases, (3) Andesites-Dacites, (4) Rhyolites, (5) Dacites-Andesites, (6) Basalts-Basaltic andesites. There are two modes of occurrence, namely, in the western Sierra Madre from fissures parallel to lines of relief, and in the Central Plateau from local vents. The intimate connection between the geologic structure and the eruptive rocks of the western United States and the mountains of Mexico is also of interest.

H. H. R.

11. *Brief notices of some recently described minerals.*—CONCHITE. This name has been given by Agnes Kelly to the calcium carbonate forming a considerable part (often associated with calcite) of the calcareous secretions of molluscan shells. This form, unlike aragonite to which it has been referred (G. Rose), is uniaxial and optically negative, as is calcite, and yet it differs from the latter mineral in some other characters. The most conspicuous difference is in the specific gravity, which is 2.87 for conchite, and 2.71 for calcite. It shows no twinning and has higher refractive indices; thus ϵ is 1.524 for conchite and 1.486 for calcite. Conchite is an unstable compound changing into calcite at 300° to 310°. Various natural incrustations (Karlsbad, Yellowstone, etc.) were found to consist of conchite; here also belongs the Flos Ferri.—*Min. Mag.*, xii, 363.

SELIGMANNITE. A new species described by Baumhauer from the dolomite of the Binnenthal in Switzerland; it is named after the mineralogist, G. Seligmann of Coblenz. The material was too scanty to allow of analysis, but its close identity with bournonite in complex crystalline form and the similarity in color and luster and brittleness to sartorite (scleroclase), have led the author to the conclusion that it is a lead sulpharsenite isomorphous with the former species.—*Ber. Ak. Berlin*, p. 110, 1991.

HUSSAKITE. A mineral occurring in tetragonal crystals and in crystal fragments at Dattas near Diamantina, Minas Geraes, Brazil. The form is identical with that of xenotime, but analysis showed the presence of 6 p. c. SO_3 . The results obtained are as follows:

	SO_3	P_2O_5	(Y, Er, Gd) $_2\text{O}_3$	Fe_2O_3
$\frac{\text{p.c.}}{\%}$	6.13	33.51	60.24	0.20=100.08.

The hardness is 5; sp. gravity 4.587; the color, yellowish white to honey-yellow and brown. The authors, Kraus and Reitingger, suggest that the xenotime hitherto analyzed may have been altered from hussakite, the SO_3 having been removed; they regard Gorceix's earlier analysis of the Brazilian mineral, which showed no SO_3 , as incorrect.—*Zeitschr. Kryst.*, xxxiv, 268.

CERULÉITE. An arsenate of aluminum and copper from the gold mines of Huanaco, Chili, described by H. Dufet. It occurs in clay-like masses of a turquoise-blue color; these masses consist of very minute crystals. The specific gravity is 2.803. An analysis gave the following results:

As_2O_5 34.56 Al_2O_3 31.26 CuO 11.80 H_2O 22.32=99.94.

This corresponds approximately to the formula $\text{CuO} \cdot 2\text{Al}_2\text{O}_3 \cdot \text{As}_2\text{O}_5 + 8\text{H}_2\text{O}$.—*Bull. Soc. Min.*, xxiii, 147, 1900.

SÜLVANITE. A sulpho-vanadate of copper described by G. Goyder from Burra, South Australia. It occurs in masses with a metallic luster and bronze-yellow color; hardness 3.5; specific gravity 4.0. The calculated formula is $3\text{Cu}_2\text{S} \cdot \text{V}_2\text{S}_5$, deduced from two analyses, one of which is as follows: S 32.54 V 12.53 Cu 47.98 SiO_2 4.97 Fe_2O_3 0.42. The silica and iron are due to impurities.—*J. Chem. Soc.*, Sept. 1900, p. 1094.

TERMIERITE, LASSALLITE. Two silicates of aluminum described by G. Friedel as occurring with kaolinite and barite at the antimony deposits of Miramont on the borders of Cantal and Haute-Loire, France. The composition of *termierite* is regarded as expressed essentially by the formula $\text{Al}_2\text{O}_3 \cdot 6\text{SiO}_2 + 18\text{H}_2\text{O}$; an analysis gave: SiO_2 78.29, Al_2O_3 15.00, Fe_2O_3 (FeO pt.?) 4.85, CaO 1.77, MgO 0.47=100.38. It occurs in small masses of a gray color and conchoidal fracture.

Lassallite occurs in white fibers resembling asbestos. An analysis of dried material gave: SiO_2 69.27, Al_2O_3 19.42, Fe_2O_3 0.84, MgO 10.01, CaO 1.30=100.84; H_2O 14.22. The calculated formula is $3\text{MgO} \cdot 2\text{Al}_2\text{O}_3 \cdot 12\text{SiO}_2 + 8\text{H}_2\text{O}$.—*Bull. Soc. Min.*, xxiv, 4, 1901.

TORRENSITE, VIELLAURITE. Supposed new minerals consisting of the carbonate and silicate of manganese described by Lienau, the former substance occurring in gray to brown masses at the Torrens mine, Haute Pyrénées. It is shown by Lacroix to be a mixture of rhodonite and rhodochrosite. The same author also shows that the *viellaurite* is a mixture of rhodochrosite with a silicate, probably tephroite, and small quantities of alabandite.—*Bull. Soc. Min.*, xxiii, 251.

VIOLAITE. A strongly pleochroic pyroxene (with green and orange-yellow colors) which forms an essential constituent of the rock from the Kedabek copper mines called by Federow *Kedabekite*. An analysis gave: SiO_2 48.26, Al_2O_3 3.84, Fe_2O_3 1.15, FeO 15.77, MgO 8.09, CaO 22.61, Na_2O 0.28=100.

12. *On Iron Meteorites.*—Prof. E. COHEN gives in a recent paper (Sitzb. Akad. Wiss. zu Berlin, Dec. 13, 1900) a summary of the results of his recent thorough and detailed chemical and structural study of the iron meteorites which lack cubic or octahedral structure. These include Brezina's group of Ataxites and his Hammond, Capeisen and Chesterville groups. The following were found by Cohen to be pseudo-meteorites: Nauheim, Newstead, Walker Co., Scriba, Hemalga, Saint Augustine's Bay, Long Creek, Virginia, and Minas Geraes. Tocavita, Salt River and Ballinoo, Cohen considers to be octahedrites with finest lamellæ; Santa Rosa a granular aggregate of octahedral individuals and Bingera a granular aggregate of cubic individuals. The remainder are grouped by Cohen under the term "*Körnige bis dichte Eisen.*" These are subdivided into (a) granular to compact, streaked (*schlierenführende*) irons and (b) granular to compact irons without streaks (*schlierenfreie*). The latter are considered the only true ataxites.

Group *a* is subdivided into (*a*) irons with octahedral streaks (*schlieren*) and includes Cacaria and Hammond, and (*β*) irons with cubic streaks (*schlieren*). This latter group includes Cape of Good Hope, Kokomo, Iquique, Shingle Springs, and Sierra de la Ternera.

Group *b*, or the true ataxites, is divided into two subgroups. The meteorites of the first subgroup are rich in nickel, the content of Ni + Co being 17–20 per cent. Those of the second subgroup are poor in nickel, the content of Ni + Co being 6–7 per cent. Under the first (Morradal group) Cohen classes Smithland, Babb's Mill, Deep Springs, Botetourt, Dehesa, Linnville Mountain and Morradal. The second is subdivided into the Siratik group, under which are included Siratik, Campo del Cielo, Locust Grove, Mesquital and Cincinnati, and the Nedagolla group, which comprises Rasgata, Chesterville, the Wöhler iron, Nedagolla, Primitiva and Forsyth Co. Tucson is considered intermediate in character, the content of nickel being about 9 per cent, while forsterite is present as an accessory constituent. Illinois Gulch is classed with the Nedagolla group although the percentage of nickel is high (12 per cent).

The author finds structure throughout dependent upon the chemical composition, thus confirming the conclusions which he had previously formed from studies of the octahedral and cubic irons.

O. C. F.

13. *Studien über den Milchsaft und Schleimsaft der Pflanzen*; by HANS MOLISCH, Director of the Institute for Plant Physiology at the German University in Prague. Pp. viii + 111, with 33 text-figures. Jena, 1900 (Gustav Fischer).—Previous writers on the milk-tubes of plants have studied more especially the development of the tubes and the structure of their walls. In the present paper, Professor Molisch gives a full account of the milky juice inside the tubes, describing its microscopic structure and chemical composition. According to the older writers, the tubes are wholly devoid of protoplasmic contents. According to the more recent work of Berthold, the whole milky juice is to be looked upon as a modified protoplasm. The author, however, finds neither view correct, but distinguishes in the intact tubes a layer of cytoplasm, which lines the wall and which has imbedded in it numerous nuclei, leucoplasts and vacuoles, and considers the space enclosed by this layer as a sap-cavity filled with a milky cell-sap. He confirms thereby the work of E. Schmidt, who found both cytoplasm and nuclei even in old tubes. In the milky juice which exudes from cut surfaces, the protoplasmic elements become so thoroughly mixed with the cell-sap that they cannot be distinguished. In addition to nuclei of the ordinary type, the author describes a peculiar variety of nucleus to which he has given the name "Blasenkern." In this the nuclear membrane is separated from the nuclear substance to a greater or less extent by a space filled with liquid. Since it is sometimes possible to convert ordinary nuclei into "Blasengerne" by the addition of water, it would seem probable that the latter were abnormal, but this view is not held by the author. The leucoplasts usually give rise to starch-grains, but, in some cases, to solid proteids or to oil-drops, both of which may also occur in the vacuoles. Other organic substances sometimes found in the milky juice are caoutchouc, resins, tannins, soluble proteids and carbohydrates and the recently described leptomin of Raciborski. The juice of the Papaveraceæ contains also various alkaloids. Whether these substances occur in the cytoplasmic sheath or in the sap-cavity could not always be determined. The slime-tubes, which are found in certain monocotyledonous families, show a structure very similar to that of the milk-tubes, but the sap-cavity contains slime, which is only occasionally milky. The nuclei are very variable in shape and are sometimes drawn out into long hair-like structures. The slime-tubes contain many of the substances found in milk-tubes. In addition to these the author describes as new an organic body to which he gives the name "luteofilin." Little could be determined with regard to its chemical composition. The luteofilin crystallizes out of the slime in the form of spherites, which show a distinct concentric lamellation. They are soluble in water but

insoluble in absolute alcohol, ether and benzole. Upon the addition of 20 per cent. potash solution, the luteofilin appears in the form of long and slender thread-like masses of a bright yellow color, from which the substance receives its name. Regarding the functions of the milk- and slime-tubes, the author does not express himself very fully, but reserves this subject for a future paper.

- A. W. E.

✓ 14. *A Remarkable Instance of the Death of Fishes, at Bermuda, in 1901*; by A. E. VERRILL.—During the month of February and the first part of March of this year the weather at Bermuda was unusually cold and wet. The temperature fell, at one time, as low as 45° F. The continued low temperature was sufficient to cool the sea water beyond the limit of endurance for many of the tropical fishes found there, so that vast numbers died and were washed ashore, especially during the first week in March, all along the coast, but more abundantly around the shores of Hamilton Harbor and the adjacent islands. The stench from their decomposition became so great that the local government was obliged to aid in their removal early in March.

Numerous species of fishes were thus affected as well as certain crabs, corals, etc. The fishes that died in the largest quantities were two of the commoner shallow-water species, viz., the hamlet grouper and the squirrel-fish. Later in the season these and other fishes that previously have always been common were found to be scarce and difficult to obtain. In fact, most of the ordinary market fishes were much scarcer and harder to obtain than ever before. Among numerous other fishes seen dead on the shores were parrot-fishes of several kinds, small rock-fishes, hog-fishes, white grunts, large porcupine-fishes, trunk-fishes, cow-fishes, angel-fishes, rainbow-flounders, etc. Also large specimens of *Octopus*.

Those fishes that habitually live in deep water, among the outer reefs, such as the red snapper, large rock fishes, amber fishes, etc., seem not to have been thus affected. Some of the smaller shallow water and surface fishes also seemed to have escaped, for the pilchards, hog-mouth fry, and others were still very abundant in April.

IV. MISCELLANEOUS SCIENTIFIC INTELLIGENCE.

1. *Atlas Meteorologico de la República Argentina* por ENRIQUE A. S. DELACHAUX. Primera Parte, Provincia de Buenos Aires. Buenos Aires: Comp. Sud-Americ. de Billetes de Banco.—This volume begins the publication of a general meteorological atlas of the Argentine Republic, which will appear from time to time as each province is studied in detail. Observations are taken at eighteen meteorological stations. The maps exhibit the main climatic factors of Buenos Aires. Thus it is shown that the annual temperature varies from 18° C. in the Parana Valley to 14° C. in the south central part; the temperature range for about

half the province is less than 14° C. The annual humidity reaches 82 per cent on the northeast coast line, while in the central and western part of the province it is under 70 per cent. The annual rainfall in the Parana delta is 1,000^{mm}, but there is a regular decrease to the southwest until the minimum (300^{mm}) is reached on the Rio Negro. About two-thirds of the province has an elevation less than 100^m.

H. E. G.

2. *The British Museum Catalogues*.—The following publications have been recently issued :

A Hand-list of the Genera and Species of Birds (Nomenclator avium tum fossilium tum viventium); by R. BOWDLER SHARPE, LL.D. Vol. ii, pp. xv, 312. London, 1900. Includes all species of *Psittaci* and what are known as Picarian birds; there are enumerated 454 genera and 2861 species. See also vol. viii, p. 398.

Catalogue of the Mesozoic Plants in the Department of Geology, British Museum (Natural History). The Jurassic Flora. I, The Yorkshire Coast. Pp. xii, 341, pl. i-xxi. By A. C. SEWARD, M.A., F.R.S., F.G.S. London, 1900.

3. *A Select Bibliography of Chemistry, 1492-1897*; by HENRY CARRINGTON BOLTON. Pp. 534. Washington, 1901. (Smithsonian Miscellaneous Collections, 1253. Section VIII. Academic Dissertation.)—Professor Bolton continues his laborious but most useful task of collecting chemical bibliography. The latest addition to the series is this large volume of academic dissertations, arranged alphabetically according to authors, but with a full subject-index to titles at the end (pp. 445-534).

4. *Publications of the Bureau of American Ethnology*, J. W. POWELL, Director.—It is impossible here to do more than record the recent issue of the following valuable volumes :

Seventeenth Annual Report of the Director with accompanying papers. In two parts: Part I, pp. xciii, 468; Part II, pp. 469-752.

Eighteenth Annual Report. In two parts: Part I, pp. lvii, 518.

5. *Field Columbian Museum*. The following is a list of recent publications :

No. 45. Zoölogical Series. Vol. II. A Synopsis of the Mammals of North America and the adjacent seas; by Daniel Giraud Elliot, curator. Pp. 470. Chicago, 1901.

No. 51. Anthropological Series. Vol. II, No. 4. An Aboriginal Quartzite Quarry in Eastern Wyoming; by George A. Dorsey, curator. Pp. 235-243. Plates xxviii-xxix. Chicago, 1900.

No. 52. Report Series. Vol. I, No. 6. Annual Report of the Director to the Board of Trustees, for the year 1899-1900. Pp. 413-512. Chicago, 1900.

No. 53. Geological Series. Vol. I, No. 8. Observations on Indiana Caves; by Oliver Cummings Farrington. Pp. 247-266. Chicago, 1901.

No. 54. Zoölogical Series. Vol. III, No. 3. List of Mammals obtained by Thaddeus Surber, Collector for the Museum in the Provinces of New Brunswick and Quebec, Canada; by D. G. Elliot, curator. Pp. 15-29. Chicago, 1901.

6. *Scientia*. L'Evolution du Pigment; per G. BOHN. Pp. 94.—This is the eleventh volume of this valuable series. Paris, 1901 (Georges Carré et C. Naud).

7. *Zoologisches Addressbuch*: Namen und Adressen der lebenden Zoologen, Anatomen. Physiologen und Zoopaleontologen, sowie der künstlerischen und technischen Hilfskräfte, herausgegeben im Auftrage der Deutschen Zoologischen Gesellschaft von R. Friedländer und Sohn. Teil II, pp. viii, 517. Berlin, 1901.—This second part of the International Zoologists' Directory (see this Journal, i, 77, 1896) includes announcements of deaths, changes of address, corrections and additions, dating from September, 1895: it thus completes this valuable work up to 1901.

8. *Publications of the Earthquake Investigation Committee in Foreign Languages, Nos. 5 and 6.*—The recent contributions to this important series, repeatedly noticed in these pages, contain the results of horizontal pendulum observations of earthquakes from July, 1898, to December, 1899, in Tokyo, by Dr. F. Omori.

9. *Publications of the United States Naval Observatory. Second Series, Vol. I*, pp. cvii, 402. Washington, 1901.—The second series of the U. S. Naval Observatory publications is commenced with the present volume. With it the plan of publication will be different from that which has been in force hitherto, since, in the place of annual volumes, it is proposed to issue volumes at suitable intervals depending upon the kind and amount of material available. We have here all the transit circle observations of the sun, moon, planets, and miscellaneous stars made from 1894 to 1899, except those of the zone $-13^{\circ} 50'$ to $-18^{\circ} 10'$. The observations were made under the direction of Prof. W. Harkness until his retirement as Director in December, 1899. Prof. A. N. Skinner was in charge of the transit circle during this period; the Directorship of the Observatory is now under the charge of Prof. S. J. Brown.

University of Tennessee Record. The April number of the Tennessee Record (vol. iv) contains a series of scientific papers; among these may be mentioned one by A. C. Lanier on technical education in the South; another by E. F. Kern on the electric current in chemical analysis; by W. W. Carson on the polar planimeter; by W. M. Fulton on automatic record of water stages in the upper Tennessee river.

The New York University Bulletin of the Medical Sciences. A publication devoted to the scientific work in the Carnegie Laboratory and other departments of the Medical College. Conducted by the New York University Medical Society of the University and Bellevue Hospital Medical College. Vol. I, No. 1, January, 1901. Pp. 56. Lancaster, Pa. and New York (The Macmillan Co.).

✓ *School Science.* A Journal of Science Teaching in Secondary Schools; edited by C. E. Linebarger with the aid of twelve associate editors. The first number (pp. 1-51) of this new periodical is dated March, 1901. It will be published monthly, September to May inclusive, by School Science, Unity Building, Chicago; price \$2.00 per year.

✓ *Memoirs of the National Academy of Sciences.* Volume VIII. Fifth Memoir. Anatomy of *Nautilus Pompilius*; by Lawrence Edmonds Griffin. Pp. 197. Plates I-XVII. Washington, 1898.

Mountain Structure and its Origin; by JAMES GEIKIE. International Monthly, January and February, 1901.

THE

AMERICAN JOURNAL OF SCIENCE

[FOURTH SERIES.]

ART. IX.—*Experiments on High Electrical Resistance*, Part II; by OGDEN N. ROOD, Professor of Physics in Columbia University.

New method of measuring high electrical resistance.—In the first part of this paper,* I have given a general account of a mode of measuring electrical resistances which are far too large to be dealt with by ordinary methods. Since then the electrometer, there indicated, has been improved, and a large number of units of resistance has been constructed. Experiments have also been made with regard to the best modes of using them, and, in particular, with respect to the best way of building up a set of high resistances, from a low, but known, resistance. Attention has been paid to electrical leakage, to the composition of the units, to their reliability during short and long intervals of time. Their behavior under different electromotive forces has been somewhat attended to, and is still under examination. A large number of details have presented themselves, and it will require considerable time before they all can be satisfactorily studied. Meanwhile this much has been ascertained: it is possible to take a low standard of resistance, measured by old methods, employing fifty or a hundred volts, and from this to build up a set of resistances, the highest of which shall be equal to fifteen or twenty millions of megohms, the original electromotive force being always adhered to. With such units of resistance it is of course easy to measure any resistance which lies within their range, employing always one and the same electromotive force. The reliability of such measurements can be judged from the results given at the end of this article. It is also certain that the

* This Journal, x, 285, 1900.

cores of the units about to be described are inaccessible to moisture, and that in ordinary weather there is no surface conduction that interferes with their accuracy. Less is known about the invariability of the units during long periods of time; this matter is being investigated by Mr. H. C. Parker, and the results thus far obtained are promising. If it should turn out that none of the varieties I have devised has this desirable quality, it would merely necessitate on each occasion where accuracy was required, a galvanometer measurement, and a building up process from it, involving two or three hours of extra labor, as changes in the units do not occur which would interfere with the ease of a building up process once established in all its details. In every case thus far examined, the resistance of the unit immediately after making it has increased with some regularity, week by week, but at a diminishing rate, and now at the present time, it is not my custom to employ units till they are at least three months old.

Electrometer.—The construction of this apparatus is shown in the sketch, fig. 1, where all the shaded portions are metallic, and the unshaded parts made of the best quality of ebonite. B is a brass binding post, to which may be attached the wire conveying the charge, also a Leyden jar or a small mica condenser. It terminates below in an aluminum leaf, bluntly pointed, and provided with a long hinge of gold leaf for flexibility. The latter is attached to a brass wire W, that slides into a well-fitting tube, from which it can readily be removed for repairs. P is a springy brass plate faced with platinum. When the apparatus has received a sufficient charge the aluminum leaf is attracted to P, and usually remains attached; V is a narrow strip of thin sheet brass fastened to an axis, not shown in the diagram, which is terminated by the milled head H; it can be made to slightly scrape the edge of the plate P, and communicate to it a trifling vibratory movement, which instantly detaches the gold-aluminum leaf. Mere contact from behind, even when made with some violence, is not sufficient for this pur-

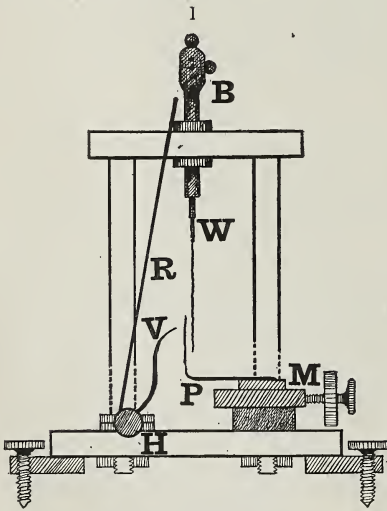

pose. R is a stiff brass wire attached to the same axis with V, and serves to discharge the apparatus; it has an arm bent at a right angle which can be brought into contact with the binding post B. A single motion discharges the electrometer and sets the gold leaf free. The axis carrying R and V is connected with the ground. The micrometer, M, is provided with a millimeter screw and carries the plate P. In all of my recent experiments it was connected with the ground. The height of the electrometer from the table, to the top of the binding post, is 27^{cm}. It is covered by a glass case to prevent air currents, the case being in contact only with the ebonite base. When in actual use the apparatus is covered by a paste-board box coated with tin-foil, through the sides of which suitable openings are made for observation, and for the introduction of the two wires that are attached to the binding post. The electrometer as thus described, with a striking distance of a half or of one millimeter, is suitable only for measuring resistances of a million megohms and upwards; lower resistances bring about a stroke in a very few seconds, and to measure these, its capacity must be increased.

Condensers.—A series of these have been employed, the greatest being a large Leyden jar with a capacity of .00507 of a microfarad; four smaller jars with diminishing capacities and three small mica-condensers have been used. When the electrometer is once made, and a few suitable resistances, such a set of condensers can easily be produced. The mica-condensers were supported by silk threads that had been heated up in a bath of wax and rosin. A long wooden rod above the apparatus carried the mica-condensers and the units, when more than three or four of them were used in a series, and in this way excellent insulation was readily obtained.

Table of Capacities of Condensers.

	Capacity in microfarads.
Leyden jar, No. 10050
“ “ 20025
“ “ 30013
“ “ 40008
“ “ 500044
Mica cond., No. 100024
“ “ 200014
“ “ 3000037
Electrometer000014

It may be remarked that the apparatus described in this paper can easily be used to determine the capacities of quite small condensers, and of conductors or semiconductors sus-

pended in the air by insulating threads. With a set of condensers like the above, the capacity of any condenser within their range can be quickly obtained.

Units of resistance.—After a number of experiments in different directions, it was decided to employ peroxide of manganese painted on strips of blue cobalt glass, which was found to be a much better insulator than colorless plate glass. The mode of construction, briefly, is as follows: washed commercial peroxide of manganese is painted with a brush on cobalt glass, the edges of the strip being avoided, and it is then dried with gentle heat. The layer thus obtained is quite adherent in spite of the fact that only water is used in making the mixture, and it can be laid on with different thicknesses and have desirable breadths. The two ends of the glass slip are then wrapt with tin-foil, and about 7^{cm} of the foil allowed to remain free at the two ends to hold the unit when it is immersed in a rosin-wax bath. Fine brass wire is used to prevent the unit from unrolling itself when it is lifted up. The rosin-wax bath contains only so much wax as does not dim the polish of the finished unit, the polish of the bath itself, when it cools, being about half destroyed. Pure yellow wax was employed, and the temperature of the bath was about 150° C. Immersion in this bath drives out air and moisture, and as more than half of the tin-foil is also immersed, it results that the unit is embedded in the insulating substance, conduction to its interior being furnished by the free tin-foil at the ends. Afterwards, while still as hot as allowed handling, the units were finished with a hot knife, care being taken repeatedly to press down the foil at the places of contact. The superfluous rosin being removed, the remainder of the tin-foil was wrapt around the ends of the units and suitable terminals of sheet brass supplied. These again were wound with flexible iron wire having a diameter of 0.4^{mm}. In this operation as much force as was considered safe was employed, in order to secure fixity, and to make sure that the pressure exerted on the foil should be far greater than any experienced afterwards in the use of holders to connect the units, or to introduce them into the circuit. It will be seen that the units are completely inaccessible to moisture, and experiments have shown that in ordinary weather their surface conduction, practically, is zero. Three-quarters of the insulating surface between the terminals have been wrapt with tin-foil without lowering the resistance, even when the hygrometer indicated 60 per cent of moisture.

The process which has been explained is suitable for the production of units having resistances from one up to ten thousand megohms. For higher units the oxide of manganese

is to be diluted with Chinese vermilion, when good substantial layers can still be used. If the amount of the oxide of manganese be reduced as low as twenty per cent, as high resistances can be obtained as any that have been handled by me. The thickness of oxide of manganese giving a resistance of only one megohm was not measured, but must have been less than one millimeter. Some of these low units, of from one to a hundred megohms resistance, were given to Mr. H. C. Parker, who is engaged in testing their constancy; he finds that they exhibit no polarization, neither have I, experimenting with higher units, detected anything of this kind, by which is meant that in neither case does the resistance increase while the current is flowing.

As already indicated, the best results were obtained by the use of an insulating material of rosin with a small percentage of yellow wax. Paraffin was also tried, but even with low units exhibited a tendency to break down and lower its resistance, temporarily; plain yellow wax was better, but both of them were liable to break down rather suddenly when the resistances were quite high. Plain peroxide of manganese on cobalt glass, not insulated by immersion in any bath, answered admirably in dry weather for rather low units (under 50,000 Ω) but in damp weather became quite unreliable.

The units employed by me were 10^{cm} long, 2^{cm} broad, each brass terminal having a length of 2^{cm}. For the higher resistances they might be made two or three times as long with advantage.

Battery.—In the earlier experiments the street current was employed with an E.M.F. of 112 volts, but was found to be unsatisfactory owing to its small variations; an arrangement of 200 cells or tubes with copper and zinc and very dilute acid is preferable, but the so-called dry cells are far better, as with such high resistances their electromotive force is almost perfectly constant, and they need no care.

Leakage.—It would appear tolerably certain that when the electrometer, with or without a condenser, is first employed, a small amount of electricity is, so to speak, absorbed by it, so that with a given unit, the time of a stroke becomes in a few minutes somewhat shorter and then remains constant. This leakage reduces itself to a minimum, but there is reason to believe that some always remains. For example, if two equal units are joined in a series, and matters are arranged so that the time of the stroke does not exceed thirty or forty seconds, then this joint time will be equal to the sum of their times used separately. If, however, this joint time is allowed to rise as high as one or two minutes, then it always exceeds the sum of the separate times by anything from four to ten per cent or

more, according to the dryness of the atmosphere. Various expedients were tried to measure and allow for this loss, but it was finally decided to compare together only resistances that were nearly equal, which is not a matter of difficulty after one has accumulated a stock of resistances, those which had been accounted failures now becoming useful. It is hardly necessary to add that if a unit, of about a given resistance, is desired, it is best, after due consideration of the case, to make five or six.

Manipulation.—One pole of the battery is connected with a contact maker which must be carefully insulated; from thence the current flows to the unit or resistance, and finally to the binding post, B. The electrometer having been discharged and the gold leaf set free, the wire R is allowed to remain for ten seconds in contact with post B, the current meanwhile flowing through the unit or resistance into the ground. As R and V are turned to the left the time is noted with a stop watch, and the leaf watched with a lens for the stroke, after which contact is immediately broken. An attempt is always made to arrange matters so that the time noted shall not be less than fifty nor more than eighty seconds, and in the case of two resistances which are being compared together, care is taken to make their times as nearly equal as possible, so as to avoid errors due to leakage. This is accomplished by the use of small subsidiary units of known resistance, which are added to either of the resistances under consideration as occasion may require. When a string of units is being compared with another string, the actual number of pieces in both cases should be the same, any deficiency being made up by the use of dummies which in all respects imitate real units, except that they have no resistance at all.

The second pole of the battery and the plate P are permanently connected with ground. The striking distance usually employed has been one millimeter throughout whole sets of experiments. Striking distances as large as seven millimeters can be used for regulating the time of the stroke, but it is better to manage this with the aid of condensers. In any case, the striking distance and the electromotive force of the battery should remain constant in a set of experiments, so that comparable results can be directly obtained without the use of coefficients. Not only can the units be used "in series," but also "in parallel," to measure smaller units.

Building up a set of resistances.—Mr. H. C. Parker measured for me a resistance which turned out to be 32,000 megohms, the electromotive force being 50 volts, and this was used as a base in building up a set which reached as high as fourteen million megohms. The plan for building up

having been arranged so that only units or sets of units of about the same resistance were compared together, it was possible to run through the entire series in three hours, and on April 20th this was done, and repeated on April 21st. The number of readings in no case exceeded three; the striking distance was one millimeter. The degree of accuracy obtainable under such circumstances can be judged from the table here given, where the resistances are expressed in megohms.

April 21st.	April 22d.
34,000	34,000
12,580	12,260
23,910	24,140
26,970	27,200
73,580	73,460
190,560	189,700
217,800	220,800
440,200	431,400
520,400	517,600
1,420,200	1,420,000
1,849,000	1,761,200
1,862,400	1,645,400
2,570,000	2,360,000
4,768,000	4,944,000
6,364,000	6,110,000
7,432,000	7,092,000
14,658,000	13,724,000

Columbia University, New York, June 1st, 1901.

ART. X.—*Mineralogical Notes*; by A. J. MOSES.(1) *Mercuric Iodide from New South Wales.*

MR. ROY HOPPING submitted to me for examination a small specimen of impure limonite from the Broken Hill Mines, which was coated upon one side with a thin layer of bright scarlet or minimum red color. Under the microscope this layer proved to be made up of little sharp-edged cubes about $1/10^{\text{mm}}$ on an edge and with slightly etched or roughened faces.

The only measurements possible were with the cross hairs. Any face brought squarely beneath the objective was either square or rectangular, or in a few observed instances not less than three and probably all four of the corners were replaced by lines equally inclined to the sides, that is corresponding to planes of the octahedron. Other faces showed linear markings parallel to both diagonals. Geometrically everything suggested the hexoctahedral class of the isometric system. No confirmation could be obtained with polarized light because of surface irregularities, while in an attempt to mount for grinding smooth the crystals became yellow and disappeared.

The following tests were made as to composition: A group of three or four crystals on a small mass of gangue was heated on a glass slide and watched, during the heating, through a hand glass. The crystals slowly and apparently completely volatilized without any visible change of color, and in a similar test in a narrow closed tube there was obtained a sublimate in part yellow but principally of the original bright red color, composed however of crystals which were rather needle-like than cubic. Two or three crystals placed on white paper and touched with a hot bead gave a sublimate corresponding exactly to the red and yellow sublimate of the iodides of mercury which is obtained by heating a mercury compound on a plaster tablet with bismuth flux.

To further check the presence of mercury, Mr. J. S. McCord made for me Behren's microchemical test for mercury, by first subliming two or three particles on a glass slide, dissolving in aqua regia, evaporating to dryness, and then adding to the dry substance a minute drop of each of ammoniac sulphocyanide and cobalt nitrate, obtaining immediately the fine groups of blue diverging needles of $\text{Co}(\text{CyS}_2)$, $\text{Hg}(\text{CyS}_2)$. A parallel test was made with artificial mercuric iodide, and throughout the behavior was the same. The deep green flame of copper iodide was obtained when a salt of phosphorus bead saturated with copper oxide was touched to a crystal of the substance and again heated.

The examination suggests very definitely mercuric iodide in isometric crystals of the hexoctahedral (holohedral) class. The tetrahedral copper iodide, marshite, and the hexagonal silver iodide iodyrite* both occur at the Broken Hill Mines, and Mr. George Smith mentions† “iodyrite associated with a bright red mineral readily tarnishing on exposure and found to be sulphide of mercury.” The specimen examined has been in my possession over a year and has not noticeably tarnished, but as the Castillos mineral coccinite is said to change on exposure, it may be that the supposed sulphide of mercury will prove to be the mercuric iodide here described.

The two descriptions of “coccinite,” the Mexican iodide of mercury, differ notably from this material. That of Castillos‡ from Zimapan and Culebras is “in acute acicular rhombic pyramids 2–6^{mm} long, fine red to yellow, changing to greenish gray and dark green on exposure; transparent to translucent. In closed tube a sublimate of Hg_2Cl_2 , white when cold and leaving residuum dull red hot, orange yellow cold and before blow-pipe turns aurora red and disappears with odor like selenium.”

The older description by Del Rio in 1828 of material from Casas Viejas, Mexico, describes particles of reddish brown color, deeper red than cinnabar, on selenide of mercury, and adamantine in luster. Castillos says the specimens labelled by Del Rio contained no iodine.

It does not seem that the name coccinite can be at once applicable to the acute rhombic pyramids of Castillos and the cubes from Broken Hill Mines, and it is hoped that more material may be found for further examination.

(2) *New Forms on Bergen Hill Pectolite.*

Mr. F. V. Cruser, student in chemistry at Columbia University, found crystallized pectolite in an abandoned quarry at Weehawken, N. J., not far from the 42d Street Ferry. The crystals are needles about 3^{mm} long by only 3/10^{mm} broad, but fair reflections were obtained from two of the crystals by use

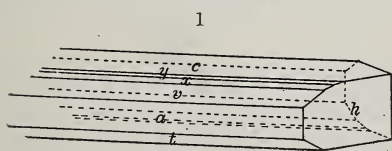

of the Goldschmidt two-circle goniometer. The crystals were mounted with the axis b normal to the vertical circle and the results later transposed to conform to the

conventional position with the axis c normal to the vertical circle.

As in previously recorded measurements the faces a (100)

* Proceedings Royal Society New South Wales, xxvi, 326 and 371, 1892; xxvii, 366, 1893; xxix, 49 and 189, 1895.

† Ibid., xxvii, 372.

‡ Dana's System, 6th Ed., 161.

yielded double signals. In the second crystal both faces of a yielded a bright and a dull signal, while in the first crystal the two signals were of equal intensity. The results following are derived from the bright signals of the second crystal.

Crystal 1 showed definitely the forms a (100), c (001), v (101) and h (540), while crystal 2 included in addition the forms t ($\bar{1}01$) and also two undescribed domes x (102) and the very flat dome $y=(1\cdot0\cdot25)$, but does not include v . Figure 1 represents all the faces. The coördinate angles as obtained, after transposition to the conventional position, and the calculated coördinate angles are as follows:

Face.	Measured.		Calculated.	
	ϕ	ρ	ϕ	ρ
c (001)	90°	5° 23'	90°	5° 20'
a (100)	90	90	90	90
v (101)	90	44 46	90	44 30
x (102)	90	30 27	90	30 30
y (1·0·25)	90	7 29	90	7 32½
t ($\bar{1}01$)	90	38 52	90	38 31
h (540)	48 36'	90	48 25	90

x , y , t and h were very minute faces yielding only faint images.

These values correspond to the angles

$$ac=\beta=84^{\circ}37'. \quad av=45^{\circ}14'. \quad ax=59^{\circ}33'. \quad ay=82^{\circ}31'. \\ a't=51^{\circ}8'. \quad ct=44^{\circ}15'. \quad hh'=82^{\circ}48'.$$

It is to be noted that a change of 3' in the determination of the position of a would almost exactly reduce the values for c , x and y to the calculated values and would lessen the differences for v and t . This amount of divergence was easily possible with the double image. On the other hand, it is to be noted that the angle ac for the isomorphous wollastonite is $84^{\circ}30'$, and that for pectolite it has been variously determined as $84^{\circ}35'$,* $84^{\circ}30'$,† $84^{\circ}40'$ ‡ and may be said to be still uncertain.

(3) *New Forms on Atacamite Crystals from Chili.*

Mr. John C. F. Randolph, mining engineer, brought from the Brilladora Mine, Paposo, near the coast in the northern part of the Province of Atacama, several masses of crystals of of atacamite which differ sufficiently from previously examined crystals to warrant description.

* Greg and Lettsom, Mineralogy 1858, p. 213.

† DesCloizeaux, Mineralogie 1862, i, p. 547.

‡ Dana, System Mineralogy 1892, p. 373.

I have been unable to identify the material with any of the occurrences described by Darapsky,* and it is evidently not the material described from 'Sierra Gorda,' of which G. F. H. Smith states† "that crystals of atacamite are rarely doubly terminated and it is not therefore possible to determine by simple measurement whether the mineral is truly holohedral," whereas the Brilladora material consists almost entirely of doubly terminated crystals. The material examined by Brögger‡ shows greater similarity than any other both in the predominating faces of the crystals and in the porous ferruginous gangue and associated minute crystals of gypsum. Brögger, however, describes the crystals as in general "poorly formed with usually deeply striated vertical zone" and rounded edges and poor terminal planes, while the specimens from Brilladora Mine consist of well-formed crystals, the prism faces, though somewhat curved and irregular, are not striated and with few exceptions the crystals are doubly terminated.

Figure 2 shows the usual form of crystal except that the modifying prism planes are represented larger than in the actual crystals, in which they are little more than knife-edge width. The crystals are not tabular but are usually of approximately equal dimensions, parallel \check{a} and \bar{b} and a little longer parallel \check{c} . They range in size from $4 \times 4 \times 6^{\text{mm}}$ down. Under magnification the faces of the prism m (110) are seen to be

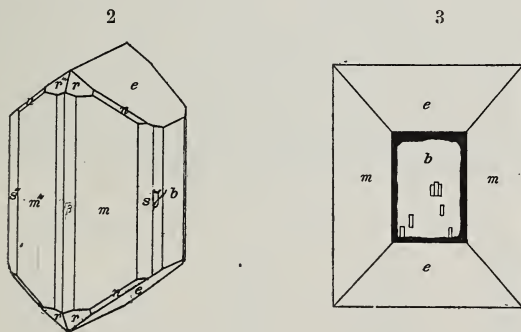

slightly curved and they yield only fair reflections. The face b (010), parallel to the cleavage, is in some crystals rough and bright, in other crystals smooth but dull and in others is centrally smooth and dull but with a narrow periphery (fig. 3) of bright material, as if the adjoining faces of m and e were covered with a thin veneer. This face b sometimes shows rectangular pittings similar to etch figures as also shown in fig. 3.

* Neues Jahrb. f. Min., ii, 1-18, 1889.

† Min. Mag., xii, 15, 1898.

‡ Zeitschr. f. Kryst., iii, 488, 1879.

On account of the minuteness of the modifying faces the measurements were made upon a Goldschmidt two-circle goniometer, and it will be noticed that the angles obtained deviate considerably from the calculated angles. The readings, however, agreed well with each other and the variation from the calculated angles are due principally to the fact that in orienting the crystals, in the absence of the basal plane, the prismatic zone was employed and in all recorded measurements either of Chilian crystals* or of those from Wallaroo, South Australia,† there have been marked variations in this zone, so great, even with the most perfect crystals, that the calculated angles only result as an average of many different crystals and measurements.

It may be noted that many of the crystals are interpenetrated and with some appearance of regularity. A careful measurement failed to prove any true twinning.

In the tabulation which follows I have calculated ϕ and ρ to the elements obtained by Smith,‡ viz: $\bar{a}:\bar{b}:\bar{c}=0.66130:1:0.75293$, and have used as a meridian a position midway between the reading for 110 and $\bar{1}10$, assuming this to be the true position of 010. Two new prisms were found, (150) designated by γ , which occurred with s (120) on one crystal in easily visible faces, the other (210) designated by β and of which two very narrow faces were observed which yielded distorted reflections. All of the measurements with the exception of γ (150) were obtained from one bright little crystal, almost octahedral in shape and approximately $1\frac{1}{2}$ mm parallel to \bar{a} , \bar{b} or \bar{c} . Two other larger crystals were measured and showed the same forms, but being less bright gave poorer reflections. On one of these the (150) prism was found.

The observed and calculated coördinates were:

Face.	Observed.		Calculated.	
	ϕ	ρ	ϕ	ρ
b 010	0° 08'	90°	0°	90°
γ 150	16 35	90	16 50'	90
s 120	37 12	90	37 05	90
m 110	56 26	90	56 31	90
β 210	72 05	90	71 42	90
e 011	0 02	37 4'	0	36 59'
n 121	37 04	61 58	37 05	62 06
r 111	56 21	53 39	56 31	53 46

* See previous references.

† Zepharovich, Ber. Ak. Wien, lxiii, 6, 1871; Klein, Neues Jahrb. f. Min., 1869, 347; E. S. Dana, Min. Mitth., ii, 103, 1874.

‡ L. c.

(4) *Realgar Crystals from Snohomish County, Washington.*

The described occurrences of realgar in this country have, I believe, none of them yielded measurable crystals.* Certainly this is the case with the stalagmitic material from Yellowstone Park described by Weed and Pirsson† and the bladed, confusedly aggregated crystals found by Blake‡ beneath the lava in Iron County, Utah.

Through the kindness of Prof. J. F. Kemp I received a specimen of crystallized realgar from a vein two to four inches thick in a tunnel of the Penn Mining Co., Monte Cristo Mining District, Snohomish County, Washington. The crystals rest upon a thin layer of nearly black tarnished marcasite.

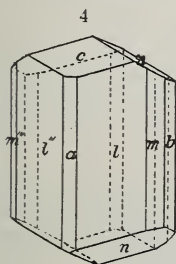

Most of the crystals are long, prismatic, and so embedded that little more can be seen than the deeply striated faces of the prism zone, sometimes 30^{mm} in length. Some smaller crystals, however, show also three terminal planes suggesting a flat rhombohedron.

The best of these crystals, approximately 2×2^{mm} cross section, was carefully detached and measured with the two-circle goniometer. The occurring forms were, as shown in fig. 4:

Pinacoids.—*a* (100) and *b* (010) small but yielding fair signals. *c* (001) large but dull.

Prisms.—The prism faces were striated, but two faces of *m* (110) yielded faint separate signals, three faces of *l* (210) yielded moderately good signals, and there were indications of faces of *h* (670).

Pyramids.—The faces of *n* ($\bar{2}12$) yielded good reflections.

The coördinate angles measured and calculated were:

Face.	Measured.		Calculated.	
	ϕ	ρ	ϕ	ρ
<i>c</i> (001)	89° 32'	23° 57'	90°	23° 55'
<i>b</i> (010)	0	90	0	90
<i>a</i> (100)	90 01	90	90	90
<i>l</i> (210)	56 18	90	56 38'	90
<i>m</i> (110)	37 11	90	37 13	90
<i>n</i> ($\bar{2}12$)	31 33	29 36	31 16	29 38

Vrba‡ figures a crystal from Bosnia with the same predominating forms.

* This Journ., xlii, 403, 1891.

† This Journ., xxi, 219, 1881, and letter.

‡ Zeitschr. f. Kryst., xv, 46, fig. 10.

(5) *Vesuvianite from New Mexico.*

Mr. W. M. Lippitt sent to me a single crystal with square cross section $5/8$ inch on a side, which is apparently vesuvianite. It was found near the surface in a low range of hills near Bear Mountain, a little west of Pinos Altos, Grant Co., New Mexico. It is corroded and dull, but with the hand goniometer gives the angles of vesuvianite as closely as could be expected. The form is the unit pyramid (111) with mere suggestions of the prism. The specific gravity is low, 3.12.

(6) *Chrysoberyl Crystal from New York City.*

Mr. W. G. Levison submitted to me for measurement a crystal of chrysoberyl which he found, in 1893, in the rock taken from an excavation on 88th Street, near Amsterdam Avenue.

It is essentially the type of heart-shaped crystal with prominent pyramid o (111) described by Cathrein* as occurring at the emerald mines of Tokowaia, and is composed of two individuals with the usual twinning plane ρ (031). It is not tabular, the dimensions in the directions of the axes \bar{a} , \bar{b} , \bar{c} being approximately $8 \times 10 \times 14$ mm. In color it is closely the green of the chrysoberyl from Haddam, Conn., and Petersdorf, Moravia.

The observed forms were:

Domes and pinacoids.— a (100), striated and yielding double images; b (010), dull; and i (011), large but very dull.

Pyramids.— o (111), bright and prominent on both individuals; n (121), small and yielding only a shimmer; ω (515), doubtful, yielding a faint image between o and o''' , but as o and o''' nearly coincide, it may be n''' of the second individual, which has essentially the same position.

Prisms.— s (120), bright and prominent, and m (110), occurring only, as indicated in the figure, in the deep striations of the faces a .

Angle.	Measured.	Calculated.	Error.
oo''	40° 11'	40° 7'	+4'
ba	90 4	90	+4
bo	70 01	69 56	+5
bn	53 58	53 51	+7
bs	46 52	46 46	—6
bm	64 57	64 50	+7
bi	60 16	59 53	+23
os	39 47	39 57	—10
$o\omega$	16 03	15 53	+10

* Zeitschr. f. Kryst., vi, 259, especially fig. 4.

The measured angles are sufficiently close to determine the forms, but are injured by the many dull faces and the difficulty of maintaining the rather heavy crystal and attached quartz in position.

The crystal was one of a cluster of three or four, as fragments of two others are visible as well as their cavities in the quartz gangue. The gangue also contains oligoclase, and attached to the sides of the cavities in the quartz are fragments of pyrite as if this mineral had filtered in between the chrysoberyl crystals and the quartz.

The crystal is shown in figure 5, the white portions shown in the faces a representing very nearly as in the actual crystal the deep grooves which yielded the signals corresponding to m (110).

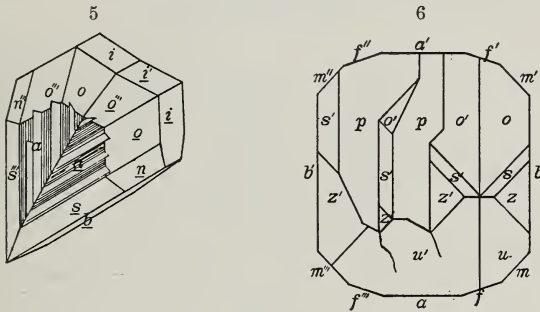

(7) *A Pyroxene Crystal from the Copper Mines of Ducktown, Tenn.*

Pyroxene crystals are recorded as occurring at the Ducktown Mines, but I have found no description of their faces, and for this reason and also for certain peculiarities I have thought this crystal worthy of description.

Among the specimens in the Egleston Mineralogical Museum is a rather large brown crystal of varnish-like luster and marked translucency. It measures in the directions of the axes \bar{a} , \bar{b} , \bar{c} approximately $25 \times 35 \times 65$ mm. The gangue includes a wedge-shaped fragment of chalcopyrite 5 mm thick and 45 mm long attached to the vertical faces and a small amount of zoisite and fibrous mineral apparently amphibole.

The peculiarity of the crystal is, that while the prismatic portion belongs to a single individual with faces a (100), b (010), m (110) and f' (310), the terminal faces indicate three individuals with a progressive change in faces, as shown in orthographic projection in figure 6, in which one face, u' ($1\bar{1}1$), is common to all three, showing only partially the lines of junc-

tion, the other faces belonging definitely to three individuals. Individual I, at the left, shows the well-developed faces z' ($0\bar{2}1$), s' ($\bar{1}\bar{1}1$) and p ($\bar{1}01$). Individual II, central, is a step above individual I and shows the combination of faces a little farther from the crystal center, and also a slight development of o' ($\bar{2}\bar{2}1$). Individual III, to the right, is composed of faces still farther from the center and is essentially complete, showing u , z , s , o , as well as u' , z' , s' , o' , but does not show p , which is the most prominent plane on I and II.

It would appear that during the growth of the crystal there was some change in conditions which resulted in a partial replacement of the comparatively smooth plane p ($\bar{1}01$) by the deeply corroded faces of o' ($\bar{2}\bar{2}1$).

Measurements were only practicable with the hand goniometer on account of the weight of the crystal.

	Measured.	Recorded.		Measured.	Recorded.
pb	91°	90°	ff'	37°	38° 36'
ob	106	105	pa'	74 +	74 30
zb	40	41 25'	oa'	60 +	61 32
sb	59	60 25	za	77	79 36
uu'	49	48 29	sa'	78	76 34
nm'''	93	92 50	ua	54	53 58

Columbia University, May 1901.

ART. XI.—*On the Motion of Compressible Fluids*; by
J. WOODBRIDGE DAVIS.

IN the case of steady motion of a perfect fluid, the Eulerian differential equations of motion can be reduced to one equation in which the variation takes place along a stream-line. The integral of this is

$$\int \frac{dp}{\rho} = -\Omega - \frac{q^2}{2} + C.* \quad (1)$$

Applied to each elemental tube of flow, that is, to a tube of variable infinitesimal thickness whose boundary is composed of stream-lines, the equation of continuity becomes

$$\sigma q \rho = M.† \quad (2)$$

$p, \rho, q, \sigma, \Omega$, are the pressure, density, velocity, area of cross-section, and potential of extraneous forces per unit mass, at the variable distance s measured along the tube; C is the constant total energy per unit mass carried along the tube; M is the constant quantity of fluid that passes any section in unit time. ρ, σ, M , are necessarily positive in a physical problem: we may always assume that the direction of the motion is positive; and this we have done in forming equation (2). Hence q also will always be positive, if the motion is physically real.

When the fluid is compressible, and the pressure is a single-valued function of density only, such that, for all positive values of density, the density increases with increase of pressure, and diminishes with relief of pressure, and the ratio of the increment of pressure to the increment of density either remains constant or increases with compression, we may write

$$p = f(\rho), \frac{dp}{d\rho} \text{ is positive; } \frac{d^2p}{d\rho^2} \text{ is zero, or is positive.} \quad (3)$$

From (1), (3),

$$\rho = \phi \left\{ \int \frac{dp}{\rho} \right\} = \phi \left\{ C - \Omega - \frac{q^2}{2} \right\} \quad (4)$$

From (2), (4),

$$q \cdot \phi \left\{ C - \Omega - \frac{q^2}{2} \right\} = \frac{M}{\sigma} \quad (5)$$

σ is a single-valued function of s ; and so is Ω for the forces of nature. But q is apparently not single-valued. At any point, it is to be found in terms of σ and Ω , by the solution of equation (5), which is equivalent to finding the inter-

* Lamb's Hydrodynamics, p. 23, eq. (3).

† L. c., p. 23, Art. 23.

sections of the curves represented by (2), (4), when σ , Ω , are constants, and ρ , q , are variables. (2) becomes the common hyperbola, which, as σ increases or diminishes, approaches or recedes from the intersection of the axes of ρ and q . One branch of this hyperbola occupies the quadrant of positive or physical values. To this quadrant we shall confine our attention. The slopes of the curves (4), (2), with respect to the

1

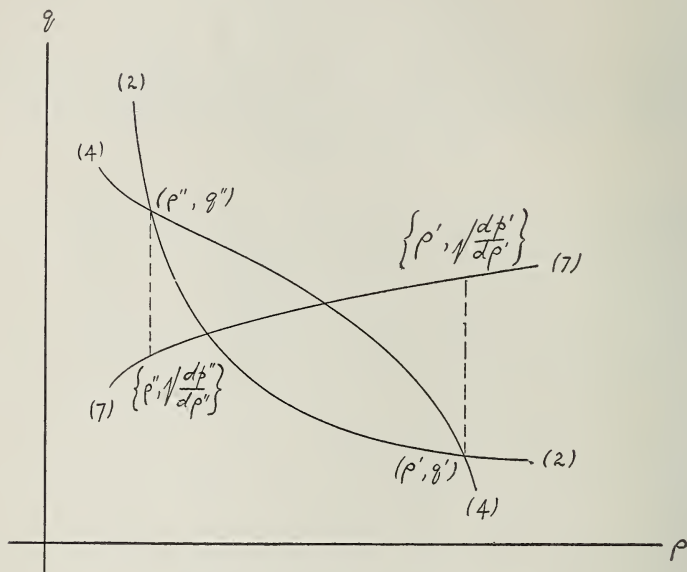

axis of ρ as a horizontal axis, that of (4) being determined from the second and third members of the equation, are

$$\frac{dq}{d\rho} = -\frac{1}{q\rho} \cdot \frac{d\rho}{d\rho}, \quad \frac{dq}{d\rho} = -\frac{q}{\rho} \tag{6}$$

Each curve continuously slopes downward from the axis of q to the axis of ρ . The line

$$q = + \left\{ \frac{d\rho}{d\rho} \right\}^{\frac{1}{2}}, \tag{7}$$

according to (3), is either parallel to the axis of ρ or continuously slopes upward; hence it necessarily intersects (2). When (7) is parallel to the axis of ρ , $d\rho$ is the product of $d\rho$ and a positive constant, the first member of (1) contains the logarithm of ρ as a factor, q in (1) or (4) is infinite where ρ is zero, and (4) reaches the axis of q at an infinite distance; hence (7)

intersects (4). When (7) has an intercept on the axis of q , one term of the first member of (1) is the logarithm of ρ multiplied by a positive constant, and (4) reaches the axis of q at an infinite distance; hence (7) intersects (4). When (7) passes through the origin, it necessarily intersects (4). Therefore, (7) always intersects (4) and (2), each in one point only.

If (4) and (2) intersect, the downward slope of the former is to the downward slope of the latter at the point of intersection according to the following ratio derived from (6):

$$\left[-\frac{dq}{d\rho} \right]_{(4)} : \left[-\frac{dq}{d\rho} \right]_{(2)} :: \frac{d\rho}{d\rho} : q^2. \quad (8)$$

At an intersection that occurs below the line (7), the downward slope of (4) is greater than the downward slope of (2); hence there cannot be more than one intersection below the line (7). Likewise, above the line (7) cannot be more than one intersection, and there the downward slope of (4) is less than the downward slope of (2). Consequently, (4) and (2) cannot intersect at more than two points.

By variation of σ , (2) can be caused to intersect (7) at every point of the latter line, and consequently at the point where (4) crosses it. (4) and (2) are here tangent to each other, as indicated in (7) and (8); and the second derivatives reduced by (7),

$$\frac{d^2q}{d\rho^2} = -\frac{1}{q\rho} \cdot \frac{d^2\rho}{d\rho^2}, \quad \frac{d^2q}{d\rho^2} = +\frac{2q}{\rho^2}, \quad (9)$$

show that the contact is of the first order, and that in the immediate neighborhood of the tangent point the line (4) is between (2) and the coördinate axes. There can now be no points of intersection of (4) and (2), since at least one of the number could not conform to the law governing the slopes of the curves at the intersection, and there can be no other tangency, because a tangency cannot occur away from the line (7). So every point of (4), except the point of tangency, is between (2) and the coördinate axes. As σ is increased without limit, the tangency becomes two intersections, and these continue to exist until the whole length of (4) is traversed to the coördinate axes, because neither of the intersections can disappear without changing into a tangency, and no tangency can occur away from the line (7). The curves (4) and (2) have, therefore, two intersections, or one tangency, or two imaginary intersections; and q in (5), if it has one positive value, has also one other positive value, and only one other.

Let q' , q'' , denote the alternative velocities at any point of the tube. (2) and (3) show that there are two corresponding alternative densities, ρ' , ρ'' , and two corresponding alternative

pressures, p', p'' . Of these two sets of values only one can represent the actual motion of the fluid; let this be q', ρ', p' . Necessarily q', ρ' are everywhere positive, according to the first paragraph, since the motion is actual; consequently q'', ρ'' are everywhere positive, according to the preceding paragraph. Hence the motion represented by q'', ρ'', p'' , which may be designated the conjugate motion, is physically real, and is connected with the actual motion by the relation, contained in (1), (2), that in each case the same quantity of energy, CM, and the same quantity of matter, M, pass any section in unit time.

Pass now to a consecutive tube. The parameters and variables of the actual motion, as contained in equations (1), (2), (3), suffer an infinitesimal variation in this passage, one factor of the variation being the distance between the tubes. As this distance is brought to its limiting value, zero, the variation in p' becomes zero, so that the normal pressures on opposite sides of a stream-line at every point are equal. That this condition of equilibrium exists is necessary to the hypothesis that there is an actual flow along these stream-lines. But the conjugate flow has the same parameters as the actual flow, and, therefore, in the passage from tube to tube, also suffers an infinitesimal variation that vanishes at a stream-line. Consequently, the conjugate flow is in equilibrium along the same stream-lines. It thus appears that any actual case of steady motion of a perfect compressible fluid whose compressibility is defined in expression (3), is one of two physically real solutions of the equations; and that the motions represented by these solutions differ in velocity at every point, but have the same stream-lines and boundaries, and discharge in unit time across any fixed mathematical surface the same quantity of matter and the same quantity of energy.

Differentiate (4) with respect to s , for the moment designating the quantity after ϕ by r :

$$\frac{d\rho}{dr} \frac{dr}{ds} = \phi' \left\{ \int \frac{d\rho}{\rho} \right\} \left\{ \frac{1}{\rho} \frac{d\rho}{ds} \right\} = \phi' \left\{ C - \Omega - \frac{q^2}{2} \right\} \left\{ -\frac{d\Omega}{ds} - q \frac{dq}{ds} \right\}. \quad (10)$$

Divide by the differential equation of (1) with respect to s ; there results

$$\phi' \left\{ \int \frac{d\rho}{\rho} \right\} = \phi' \left\{ C - \Omega - \frac{q^2}{2} \right\} = \phi' =, \text{ by (10), } \frac{\rho d\rho}{dp}. \quad (11)$$

Now differentiate (5), using the several values of ρ , $d\rho \div ds$, and ϕ' in (4), (10), and (11) as convenience directs:

$$\rho \frac{dq}{ds} + q \frac{\rho d\rho}{dp} \left\{ -\frac{d\Omega}{ds} - q \frac{dq}{ds} \right\} = -\frac{q\rho}{\sigma} \frac{d\sigma}{ds}, \quad (12)$$

$$\frac{dq}{ds} = \frac{q}{q^2 - \frac{dp}{\rho}} \left\{ \frac{dp}{\rho} \frac{1}{\sigma} \frac{d\sigma}{ds} - \frac{d\Omega}{ds} \right\}. \quad (13)$$

Let q' be the lesser of the alternative velocities, and q'' the greater. It has already appeared, as illustrated in figure 1, that q' is less than $\sqrt{d\rho' \div d\rho'}$, and that q'' is greater than $\sqrt{d\rho' \div d\rho'}$. $\sqrt{d\rho \div d\rho}$ is the velocity of sound in the fluid where the density is ρ . It will be simpler and more intelligible to consider separately the effects of changes in σ and Ω ; that is, to treat one as a constant while the other varies. Thus we learn from (13) that where the tube is narrowing, or the potential increasing, q' increases, and q'' diminishes; that where the tube is widening or the potential diminishing, q' decreases and q'' increases; and that where the tube is uniform in section, or the potential constant, q' and q'' do not change. Comparison of this statement with figure 1 shows, moreover, that the curve (4) approaches the intersection of the axes while Ω increases, and recedes from this point while Ω diminishes.

When q' , q'' , become equal, each satisfies equation (7). If this happens where the tube is narrowing, or the potential increasing, $dq \div ds = \pm \infty$, the upper sign pertaining to q' and the lower to q'' . Represented graphically, with distances laid off as abscissæ and velocities as ordinates, the meeting of q' , q'' occurs at a vertex having its convexity on the positive side. Beyond the vertex extend imaginary values to the section where appears a vertex with its convexity on the negative side. This must be where the tube is widening, or potential decreasing, and the velocity of the fluid is equal to the velocity of sound.

Equation (5) shows that wherever σ has the same value in the tube, extraneous forces not acting, or wherever Ω is the same in a tube of uniform cross-section, the values of q are the same. Hence the alternative velocities become equal, in the one case, wherever in the tube σ has a particular value, and, in the other case, wherever Ω has a particular value; and, wherever σ is less, or Ω is greater, than its particular value, the curves (4), (2), have receded from each other, and the velocities are imaginary; and, wherever σ is greater, or Ω is less, than the particular value, the curves (4), (2), have advanced upon each other, and the velocities are unequal, and become more and more separated as σ or Ω departs from its particular value.

While we confine our attention to a particular cross-section of the tube, suppose the quantity of matter, M , that in unit time flows across any section, retaining the constant energy C per unit mass, continuously increases from zero, as in an

infinite number of consecutive cases of steady motion. σ and Ω are now constant; the curve (4) is fixed, and the curve (2) recedes from coincidence with the axes to an indefinite distance. The alternative velocities approach each other, become equal, and become imaginary. Each section has, therefore, a limited capacity for the discharge of fluid. Evidently this capacity varies as σ , and is greater as the curve (4) is farther from the intersection of the axes, or as Ω is less, or as C is greater, and is less as Ω is greater or C is less. If the energy per unit mass should also increase with sufficient rapidity, the capacity of each section would not be reached; otherwise, it is ultimately reached, and the section whose area is least, or at which the potential is greatest, limits the capacity of the tube as a conduit.

When the capacity of the tube is not reached, the velocity is either everywhere less than the velocity of sound, or everywhere greater. When the capacity of the tube is reached, the velocity at the section of least area or where the potential is greatest, is equal to the velocity of sound at that point, and there the first derivative of the velocity with respect to distance assumes the indeterminate form $\frac{0}{0}$. To resolve this, differentiate (2) with respect to s , and cancel the term containing $d\sigma \div ds$; then

$$\frac{d}{ds} \left\{ \frac{dp}{d\rho} \right\} = \frac{d^2 p}{d\rho^2} \frac{d\rho}{ds} = - \frac{d^2 p}{d\rho^2} \frac{\rho}{q} \frac{dq}{ds}. \quad (14)$$

With the aid of (14) differentiate numerator and denominator of (13) once and solve for $\frac{dq}{ds}$:

$$\frac{dq}{ds} = \pm \sqrt{\frac{\frac{dp}{d\rho} \frac{q}{\sigma} \frac{d^2 \sigma}{ds^2}}{2q + \frac{d^2 p}{d\rho^2} \frac{\rho}{q}}}, \quad \text{or} \quad \pm \sqrt{\frac{-q \frac{d^2 \Omega}{ds^2}}{2q + \frac{d^2 p}{d\rho^2} \frac{\rho}{q}}}. \quad (15)$$

When $\frac{d^2 \sigma}{ds^2}$, or $\frac{d^2 \Omega}{ds^2}$, is zero, $\frac{dq}{ds} = \pm 0$.

When the capacity of the tube is reached, the conjugate flows meet at the critical section with equal velocities, densities, and pressures, and are, consequently, there indistinguishable. On either side of this section, which of the two possible flows is actual, is determined by conditions existing on that side. Hence it is possible for the actual flow to have a velocity less than sound on one side and greater on the other. That this is not a natural case appears as follows: On either side of

the critical section the density in one of the flows is everywhere considerably greater than in the other, and, therefore, the mass of fluid is considerably different in the two flows. Now suppose the quantity, M , of fluid passing any section in unit time increases from zero to the capacity of the critical section. Through all this range the velocity of the fluid everywhere in the tube remains on one side of the velocity of sound until at the limit it may still remain everywhere on that side, or may pass from one side to the other at the critical section. Hence one solution at the limit is continuous with all the previous solutions, and the other is isolated. The isolated case cannot originate from a flow that increases to the capacity of the tube, for this would involve at the final instant in the total mass of the fluid an instantaneous change of considerable magnitude. Neither can it exist in a tube that returns into itself and has only one section of least area or of greatest potential.

The behavior of the conjugate flows in any space may be summed up as follows: If in either flow the velocity of the fluid at any point is less than the velocity of sound at that point, then, in general, the velocity of the fluid is everywhere less than the velocity of sound, or may reach the latter as a limit. If the velocity is greater than that of sound at one place, it is greater at all places, or may diminish to the velocity of sound as a limit. One conjugate velocity is everywhere greater than the other conjugate velocity, or may diminish to equivalence with the latter as a limit where each becomes equal to the velocity of sound. The places of greatest velocity and least density in one case are the places of least velocity and greatest density in the other. In the approach to a gorge or place of higher potential the more rapid flow is retarded and the other is accelerated; the recession from a gorge or place of higher potential produces inverse effects. Under very special conditions the velocity of the fluid is not limited by the velocity of sound.

There is an inferior limit, ρ_0 , to the density of a compressible liquid, whereas the density in the pressure-density formula, (3), of that liquid, and, therefore, in equation (4), is continuous from zero to infinity. Hence the foregoing conclusions have a limited application to liquids. Suppose the line $\rho = \rho_0$ to be drawn in figure 1. If now the actual motion is such that both intersections of (4) and (2) always occur on the positive side of the line $\rho = \rho_0$ for every elemental tube of flow, there is also a conjugate motion; otherwise, there is no conjugate motion, and the conclusions of the preceding paragraph are only partially applicable.

NOTE. On page 177, volume x of the *Memoirs of the Manchester Literary and Philosophical Society*, 1887, in a paragraph of a paper entitled "On the Flow of Gases," read before the Society November 17, 1885, Professor Osborne Reynolds notes that, when a gas is flowing through a channel of variable section, the pressure at every point of the channel may have in general either of two unequal values; whereas, if the fluid were incompressible, the pressure could have but one value. This is the only published notice the present writer has seen of the dual values that occur in problems relating to the motion of compressible fluids. The apparent governing effect of the velocity of sound upon the behavior of compressible fluids, is set forth in an interesting manner by Professor Reynolds in the paper just mentioned, and by Hugoniot in a communication published in *Comptes Rendus*, page 1178, volume ciii, 1886, in the case considered by these authors of a flow through an orifice or minimum section. The present writer has recently been perplexed by meeting with the dual values in several problems. Professor Horace Lamb of Manchester, England, who courteously examined one of the problems, and rendered the solution more definite by employing the method of discussing the intersections of the curves (2), (4), as followed in this paper, expressed the decided opinion that only those values which are continuous with the observed or assumed values at a given point belong to the problem in hand. Impressed by this statement, the writer set about inquiring into the meaning of the values that appear, only to be disregarded, with the result, arrived at in the foregoing paper, that they belong to a separate motion related to the actual motion, as the branches of a hyperbola are related, by having the same equations and the same parameters.

ART. XII.—*The Action of Sodium Thiosulphate on Solutions of Metallic Salts at High Temperatures and Pressures*; by JOHN T. NORTON, JR.

[Contributions from the Kent Chemical Laboratory of Yale University—C.]

THE use of sodium thiosulphate as a substitute for hydrogen sulphide in effecting precipitations and its application in the case of arsenic, antimony, copper and platinum was suggested by Himly* before the middle of the present century. Thirteen years later Vohl† and Slater,‡ independently, drew attention to this use of sodium thiosulphate and extended the investigation to salts of tin, mercury, silver, gold, lead, bismuth and cadmium. Slater in addition studied the action of sodium thiosulphate upon chromic acid, molybdates, ferrous and ferric ferrocyanides, ferric sulphocyanide and potassium permanganate. Following out these lines, the precipitation of copper together with arsenic and antimony by treating with sodium thiosulphate the hot solution containing sulphuric acid and the separation of these elements from tin, zinc, iron, nickel, cobalt and manganese has been advocated by Westmoreland§; and quite recently Faktor|| has studied the action of sodium thiosulphate upon neutral salts of several of the elements mentioned, as well as the modifying influence of ammonium chloride and other salts upon the course of the reaction.

Subsequently to the work of Himly, Vohl, and Slater, Chancel¶ developed his well-known method for the precipitation of aluminum as the hydroxide and its separation from salts of iron by boiling with sodium thiosulphate the nearly neutral solution, containing the salts of aluminum and iron, at suitable dilution; and upon an extension of the principle of Chancel's separation of aluminum from iron, Stromeyer** founded his well-known processes for the separation of titanium and zirconium from iron. The latter process appears to be fairly trustworthy; but of Chancel's method, although it has met with wide acceptance, it was shown by Wolcott Gibbs very soon after its announcement†† that it fails to bring about complete separation of alumina within a reasonable period of boiling, and this result has been confirmed by Zimmerman,‡‡ who has shown that the boiling must be continued fifteen hours in order to complete the precipitation of the alumina.

* Ann. Chem. (Liebig), xliii, 150.

† Chemical Gazette, 1855, p. 369.

‡ Centralblatt, 1900, ii, 20, 67, 239, 594.

** Ann. Chem. (Liebig), cxlii, 127.

‡‡ Inaug. Diss., Berlin, 1887.

† Ann. Chem. (Liebig), xcvi, 237.

§ Jour. Soc. Chem. Ind., v., 51.

¶ Compt. rend., xlvi, 987.

|| Zeitschr. anal. Chem., iii, 389.

It was shown by Dr. Gibbs that when the treatment of salts of aluminum by thiosulphate was carried on in sealed tubes under pressure at 120° C., the precipitation of alumina was complete, and further that the precipitation of sulphides of nickel, cobalt and iron, though partial under ordinary atmospheric pressure, was made complete by heating in sealed tubes to 120°–140° C.

In repeating the experiments of Dr. Gibbs qualitatively and extending them, I have made use of the well-known Pflugst tube to secure the necessary pressure. In each experiment a test tube containing the mixture of an excess of sodium thiosulphate with the salt whose action was studied was placed within the Pflugst tube containing some water, the cover of the latter was set in place and firmly bolted upon a washer of lead, and the whole was submitted to temperatures varying from 140° to 200° C. for an hour by immersing in a bath of paraffine. After cooling, the test tube was taken out, the precipitate was filtered off, and the filtrate tested by appropriate reagents to determine the completeness of precipitation. The following table records the details of these experiments :

ACTION OF $\text{Na}_2\text{S}_2\text{O}_3$ ON SALTS UNDER PRESSURE.

Salts used.	Precipitates.	Degree of Precipitation.
	<i>Sulphides.</i>	
NiSO_4	$\text{NiS} + \text{S}$	Complete.
CoSO_4	$\text{CoS} + \text{S}$	“
FeCl_3	$\text{FeS} + \text{S}$	“
ZnSO_4	$\text{ZnS} + \text{S}$	“
$\text{PbO}_2(\text{C}_2\text{H}_3\text{O})_2$	$\text{PbS} + \text{S}$	“
$\text{Hg}(\text{NO}_3)_2$	$\text{HgS} + \text{S}$	“
AgNO_3	$\text{Ag}_2\text{S} + \text{S}$	“
CuSO_4	$\text{CuS}_2(\text{Cu}_2\text{S}) + \text{S}$	“
CdSO_4	$\text{CdS} + \text{S}$	“
$\text{KSbC}_4\text{H}_2\text{O}_7$	$\text{Sb}_2\text{S}_3 + \text{S}$	“
$\text{Bi}(\text{NO}_3)_3$	$\text{Bi}_2\text{S}_3 + \text{S}$	“
	<i>Hydroxides.</i>	
$\text{NH}_4\text{Al}(\text{SO}_4)_2 \cdot 12\text{H}_2\text{O}$	$\text{AlO}_3\text{H}_3 + \text{S}$	“
$\text{K}_2\text{Cr}_2\text{O}_7$	$\text{CrO}_3\text{H}_3 + \text{S}$	“
K_2ZrF_6	$\text{ZrO}_4\text{H}_4 + \text{S}$	“
K_2TiF_6	$\text{TiO}_4\text{H}_4 + \text{S}$	“
$\text{Th}(\text{NO}_3)_4$	$\text{ThO}_4\text{H}_4 + \text{S}$	“
	<i>Elements.</i>	
SeO_2	$\text{Se} + \text{S}$	“
TeO_2	$\text{Te} + \text{S}$	“

Salts used.	Precipitates.	Degree of Precipitation.
	<i>Sulphides.</i>	
MnSO ₄	MnS + S	Partial.
AuCl ₃	Au ₂ S + S	"
(NH ₄) ₂ MoO ₄	MoS ₃ (?) + S, Red liquid	"
	<i>Hydroxides.</i>	
BeCl ₂	BeO ₂ H ₂	"
	<i>Undetermined.</i>	
(NH ₄) ₂ U ₂ O ₇	Black	"
K ₂ PtCl ₆	Gray, reddish brown liquid	"
CeCl ₃	White, yellow liquid	"
CaCl ₂	" " "	"
SrCl ₂	" " "	"
BaCl ₂	" " "	"
MgSO ₄	—————	Trace.
NH ₄ VO ₃	Brown liquid	"
H ₂ KAsO ₄	—————	"

A perusal of this table brings to light several interesting facts. It appears that salts of nickel, cobalt, iron, zinc, lead, mercury, silver, copper, cadmium, antimony and bismuth are completely precipitated as sulphides by sodium thiosulphate under the prevailing conditions of temperature and pressure. In the case of manganese precipitation is only partial, and arsenic does not seem to be precipitated from an arsenate without the addition of acid. Tin, curiously enough, is not thrown down as the sulphide from a stannous salt, but gives a dirty white precipitate of uncertain composition. Salts of aluminum, chromium, titanium, zirconium and thorium are completely precipitated as the hydroxides; but in the case of beryllium, which one would expect to act similarly, the precipitation as the hydroxide is incomplete. Salts of selenium and tellurium are reduced, and the elements are precipitated. The precipitates obtained with barium, strontium and calcium were white in a bright yellow liquid, but no study was made of the constitution of precipitate or liquid. In the case of magnesium there was no precipitate. Salts of molybdenum, vanadium and uranium gave dark-colored liquids. Thallium yielded a white spongy mass which on compression was reduced to a very small bulk without disintegrating. Salts of gold and platinum gave slight dark precipitates, presumably sulphides, surrounded by dark-colored liquids.

The apparatus used in these experiments and described above is easily handled and answers sufficiently well for qualitative purposes. But, obviously, the introduction into precipitates of foreign matter caused by the action of water on

the glass of the test-tube and porcelain lining of the Pfungst tube precludes the possibility of an exact quantitative study of the reactions involved. For the subsequent experiments, therefore, conducted upon the same general lines, a digester with an interior cylindrical cavity of about 12^{cm} in depth by 5^{cm} in diameter, and provided with a pressure gauge, was employed. As a container for the solutions to be tested use was made of a platinum cylinder, 4^{cm} in diameter and 10^{cm} deep, provided with a loose cover. With this apparatus the following quantitative experiments, which deal with those elements which are precipitated as hydroxides, namely, aluminum, beryllium, chromium, zirconium and titanium, were made.

In each case a weighed quantity of the salt taken for the experiment was dissolved in 50^{cm} of water in the platinum vessel, and to this a known amount of sodium thiosulphate was added. The vessel was placed in the digester, and the latter was heated by a Bunsen burner in the customary way until the required pressure was shown on the gauge. The apparatus was then cooled and the platinum vessel removed from the digester. The precipitate was filtered off on ashless paper, ignited, and weighed.

Experiments with a Salt of Aluminum.

In a series of experiments made according to the method of Chancel, the results of which are shown in Table II, the solution in water of a weighed portion of pure ammonium alum was treated with an excess of sodium thiosulphate and boiled vigorously for periods varying from ten minutes to half an hour.

TABLE II.

	Amount of Alum taken as Al ₂ O ₃ . grms.	Amount of Na ₂ S ₂ O ₃ . grms.	Al ₂ O ₃ found. grms.	Error. grms.
1.	·0537	Large excess	·0471	·0066 —
2.	·0537	“ “	·0397	·0140 —
3.	·1083	“ “	·0931	·0152 —
4.	·1137	5 grms.	·0979	·0158 —
5.	·1139	2 “	·1002	·0137 —

These results substantiate the observations of Gibbs* and of Zimmerman,† and show clearly that the boiling of solutions of the aluminum salt and sodium thiosulphate for a reasonable time does not effect the complete precipitation of aluminum as the hydroxide.

Table III shows the result of submitting solutions of ammonium alum treated with varying quantities of sodium thio-

* Loc. cit.

† Loc. cit.

sulphate to a pressure of 20 atmospheres in the digester. It usually required about 40 minutes to raise the pressure to the limit set; but this limit once reached, the digester was allowed to cool slowly. The duration of an experiment was about two hours.

TABLE III.

Alum taken as Al_2O_3 . grms.	Amount of $\text{Na}_2\text{S}_2\text{O}_3$ used. grms.	Al_2O_3 found. grms.	Error. grms.
·0565	5	·0633	·0068 +
·1132	10	·1154	·0022 +
·1153	5	·1186	·0033 +
·1128	3	·1129	·0001 +
·1126	3	·1142	·0016 +
·1128	2	·1120	·0008—
·1136	2	·1121	·0015—
·1128	2·5	·1136	·0008 +
·1124	2·5	·1127	·0003 +
·1134	2·25	·1133	·0001—

This table shows that sodium thiosulphate precipitates aluminium completely as the hydroxide when pressure is employed. The high results seen in some of the experiments appear to be due to the difficulty of removing by ignition the large amounts of sulphur formed in the action, as well as to the salts mechanically included in the precipitate. The amounts of sulphur and contaminating salts present depend upon the amount of thiosulphate taken; therefore this should be as small as possible, 2 to 3 grms. being sufficient to precipitate all the alumina in a gram of alum. When the amount of thiosulphate is reasonably restricted the weights of alumina accord fairly well with the theory.

Experiments with a Salt of Chromium.

Up to the time of the completion of this work nothing appears to have been done upon the quantitative precipitation of chromium as the hydroxide by means of sodium thiosulphate. Slater* and Rose† make mention of the action of sodium thiosulphate upon chromic acid, bichromates and neutral chromates, but give no quantitative data. Recently, however, F. Faktor‡ has studied the action of sodium thiosulphate on chromium compounds. This investigator has found that if aqueous solutions of potassium bichromate and sodium thiosulphate are boiled together, a brown precipitate of hydrated Cr_2O_3 , CrO_3 separates out and the liquid turns yellow owing to

* Loc. cit.

† Traite de Chimie Analytique, vol. i, p. 479.

‡ Zeitschr. anal. Chem., 1900, xxxix, 345.

the formation of normal chromate. A solution of potassium chromate is unaffected by boiling with thiosulphate, but in presence of ammonium or of magnesium chloride the chromium is separated rapidly and completely in the same form as with the bichromate, and after continued boiling with an excess of thiosulphate all the chromium present is precipitated. Faktor also found that a solution of chromic chloride is completely decomposed by continued boiling with thiosulphate, chromic hydroxide and sulphur being precipitated.

In the experiments shown in Table IV a weighed quantity of pure potassium bichromate was dissolved in water, a known amount of sodium thiosulphate added, and the whole submitted to a pressure of 20 atmospheres in the digester. After cooling, the precipitate was filtered off on an ashless paper, ignited and weighed as Cr_2O_3 .

TABLE IV.

	$\text{K}_2\text{Cr}_2\text{O}_7$ taken as Cr_2O_3 . grms.	Amount of $\text{Na}_2\text{S}_2\text{O}_6$. grms.	Cr_2O_3 found. grms.	Error. grms.
1.	.1330	3	.1341	.0011 +
2.	.1330	2.5	.1326	.0004 -
3.	.1322	2.5	.1318	.0004 +
4.	.1303	2	.1303	.0000 -
5.	.1301	2	.1310	.0009 +
6.	.1320	2	.1322	.0002 +

The results of these experiments are very satisfactory and show that under pressure sodium thiosulphate precipitates chromium rapidly and completely as the hydroxide. It is advisable to use as small a quantity of thiosulphate as possible in order to prevent the presence of much free sulphur in the precipitate.

Experiments with a Salt of Beryllium.

In experiments dealing with beryllium the salt used was the chloride, a certain amount of which was dissolved in water diluted to a liter and the amount of beryllium present determined by precipitating with ammonia and weighing as the oxide. Measured quantities of this solution were drawn from a burette as required. When a solution of a salt of beryllium and sodium thiosulphate are merely boiled together, nearly all the beryllium remains in solution. It was expected that the use of pressure would throw out all the beryllium, but, curiously enough, when solutions of beryllium chloride and sodium thiosulphate were submitted in the digester to pressures ranging from 10 to 80 atmospheres, only a partial precipitation of the hydroxide took place.

Experiments with Salts of Zirconium.

To prepare a standard solution of the salt of zirconium it was found to be most convenient to heat the double fluoride of potassium and zirconium with sulphuric acid, evaporate to dryness in platinum, dissolve the zirconium sulphate remaining in water and enough sulphuric acid to prevent the precipitation of the basic salt, and dilute to standard volume. Measured portions of the solution were taken from a burette as required for the experiments. The presence, however, of so large an amount of sulphuric acid as was necessary to keep the zirconium salt in solution tends to decompose sodium thiosulphate so rapidly that it was found necessary to nearly neutralize the solution with ammonium carbonate before adding the sodium thiosulphate. The solution of zirconium sulphate was standardized by precipitating with ammonia and weighing as the oxide.

In experiment 1 of Table V, the solutions of zirconium sulphate and sodium thiosulphate were boiled together for a few minutes and then the precipitate filtered off, ignited and weighed as the oxide. In experiments 2-5 inclusive, similar solutions were submitted to a pressure of 20 atmospheres in the digester.

TABLE V.

	ZrO ₂ taken. grms.	Na ₂ S ₂ O ₃ taken. grms.	ZrO ₂ found. grms.	Error. grms.
1.	·0658	3	·0651	·0007 -
2.	·0658	3	·0676	·0016 +
3.	·0666	2	·0670	·0004 -
4.	·0641	2	·0648	·0007 +
5.	·0641	2	·0645	·0004 +

These results clearly show that sodium thiosulphate precipitates zirconium completely as the hydroxide either with or without the aid of pressure.

Experiments with a Salt of Titanium.

The solution of the salt of titanium was obtained by treating the double fluoride of potassium and titanium with sulphuric acid, evaporating to dryness, and dissolving the residue in sulphuric acid and water. The solution was standardized by precipitating the titanium hydroxide with ammonia and then adding an excess of acid as recommended by Gooch.* This method of procedure avoids the tendency to excessive weight observed when the titanium hydroxide is precipitated by ammonia in presence of salts of the alkalis.

* Amer. Chem. Jour., vii, 285.

In the following table is shown the effect of treating a solution of titanium sulphate with sodium thiosulphate. Experiment 1 was conducted by merely boiling a solution of the reagents named above, filtering off the precipitate and weighing as the oxide. In experiments 2 and 3 the solution of titanium sulphate and sodium thiosulphate was submitted to a pressure of 20 atmospheres in the digester.

TABLE VI.

	TiO ₂ taken. grms.	Na ₂ S ₂ O taken. grms.	TiO ₂ taken. grms.	Error. grms.
1.	·0240	2	·0237	·0003 —
2.	·0240	2	·0240	·0000 ±
3.	·0240	2	·0240	·0000 ±

These results show that titanium is completely precipitated by sodium thiosulphate either with or without the aid of pressure.

To recapitulate: I have shown that sodium thiosulphate will completely precipitate aluminum, chromium, zirconium and titanium as the hydroxides with the aid of high temperature and pressure. Beryllium is only partially precipitated under similar conditions. Mere boiling for a reasonable time will not precipitate aluminum and chromium, but it is sufficient in the case of zirconium and titanium.

In conclusion I wish to thank Prof. F. A. Gooch for his kind advice and assistance.

ART. XIII. — *Secondary Undulations Shown by Recording Tide-gauges*; by A. W. DUFF.

ON recording tide-gauges at many ports rapid oscillations are observed crossing and recrossing the main tidal record. Mr. W. Bell Dawson* in a short article seems to have been the first in recent years to recall attention to these "secondary undulations," and well describes them as standing "in much the same relation to the main tidal wave as a higher octave would to a low musical note when their undulations are recorded graphically." Others have given occasional attention to them, especially Mr. F. Napier Denison,† whose two brief papers suffer somewhat from a lack of detailed evidence for the "ten chief points deduced" and too exclusive a concern with the meteorological aspects of the question. No one seems to have attempted to give a full account of the phenomena for even a limited region. The best field for the study of the question is apparently the Eastern coast of Canada bounded by the Bay of Fundy, the Atlantic Ocean and the Gulf of St. Lawrence, where, because of the great extent and complexity of the tides, numerous recording tide-gauges have been established in the interest of navigation.

Four years ago I published‡ some observations made at St. John, N. B. The evidence advanced, depending on a calculation of the period of undulation from the dimensions of the basins in the neighborhood, seemed to point strongly to the undulations being of the nature of free vibrations of a partially confined body of water under the force of gravity. Two years ago I took advantage of a visit to Ottawa, Canada, to examine (with the permission of the authorities of the Tidal Survey of the Dominion of Canada, to whom my thanks are due for their courtesy) the tidal records from the Canadian tidal stations and made extensive notes therefrom. Other occupations interfered with the pursuit of the subject, but as no one has since then taken it up, I have thought it well to publish a brief outline of the information gathered together with an examination of its bearing on certain proposed explanations.

Materials studied.

In order to make clear the extent of the data employed in what follows, it may be stated that the tidal records from twenty stations were examined in detail, these records covering

* Trans. Roy. Soc. Can., i, 1895-96.

† Proc. Can. Inst., Jan. 16, 1897; April 23, 1898.

‡ This Journal, iii, 406, 1897.

a period of seven years, although the records from many stations covered a much shorter period. In all, the records of 404 tides or parts of tides that presented evidence of secondary undulations were copied carefully on tracing paper. In addition, the files of the Atlantic Pilot Chart (monthly) and the Canada Weather Map (weekly), were examined and in many cases copied for periods corresponding to the tracings of tidal records. From the Admiralty Charts of the region the width and mean depth of many bays and channels were obtained. To facilitate the work of any future investigator, I shall, so far as possible, give the dates of occurrences noted (usually in foot notes), but I find that occasionally my notes of dates are somewhat imperfect.

The period, extent and general nature of the undulations.

In the following statements of observed periods of regular undulations, I have not, so far as I know, omitted any occasions on which regular undulations could be observed no matter what the period might seem to be (except in the cases of St. John and Halifax, for which the records are too extensive to be quoted in full). In reference to the fewness of these occasions at certain stations, it is to be remembered that at many places tide-gauges were maintained for a few months only.

1. St. John, N. B. (on the Bay of Fundy). Here the undulations are frequent, sometimes continue for as much as a week, and vary in extent from an inch to a foot; but, when very slight, they are hardly distinguishable owing to the great extent of the tide (at spring tides 28 feet). The undulations are more nearly regular and periodic than at any other station, the mean period (the evidence for which will be stated in another connection) being 41 minutes. Occasional variations of several minutes from the mean period are found, but slight irregularities at times make the estimation of the period difficult. The undulations occur about four times as frequently in winter as in summer.

2. Yarmouth, N. S. (on the Bay of Fundy). The undulations are very common especially near low tide when they are usually present, and in certain extreme cases (e. g. Jan. 1, 1899) nearly five feet in amplitude; at high tide they are much less marked. Frequently they are more or less irregular, whereas at other times (e. g. Dec. 31, 1898) as many as ten regular oscillations may be measured. From twelve records of low tide which showed regular undulations the following mean periods were deduced:* 28, 27, 34, 34, 28, 32, 26, 22, 31, 34, 28, 34,

* June 26 (5 undulations); July 2 (6), 5 (5), 6 (4); Aug. 30 (7); Sept. 8 (5), 11 (6), 18 (5); Oct. 12 (6), 16 (4), 30 (8), 30 (4); Dec. 31 (10)—all in 1898.

28 minutes—final mean 30m. At high tide the period is entirely different and fewer complete oscillations occur :* 65, 70, 70, 67, 70, 68, 75, 65, 72, 69, 65, 65, 70, 70m.—mean 69m. At times of violent disturbances during gales there is a tendency for oscillations of both periods to persist, along with a running accompaniment of very minute and very rapid oscillations.

3. Digby, N. S. (on Annapolis Basin connected with the Bay of Fundy by a narrow strait—Digby Gut). The undulations are always small, rarely exceeding an inch and therefore difficult to measure with accuracy. On the only occasions when the extent was sufficient the periods were:† 12, 11, 11, 11, 10, 11, 13—final mean 11m.

4. Westport, N. S. (on Bryer Island, Bay of Fundy, facing Grand Passage between Bryer Island and Long Island). Undulations are comparatively rare, of short period, and never exceeding 4 inches; usually they are very irregular and have an appearance of two or more systems superposed. The gauge only ran for a few months and on only six occasions were there clear oscillations, and on only three occasions did steady regular oscillations seem to emerge from the confusion, the mean periods being:‡ 17, 14, 16 m.—mean 15 m. (but not much reliance can be placed on this figure).

5. Welchpool, Campobello Island, N. B. (on a narrow winding channel flowing into the Bay of Fundy). Here there seem to be no secondary oscillations.

6. Hopewell Cape, N. B. (on Shepody Bay at head of Bay of Fundy). 7. Parrsboro, N. B. (on Minas Basin at the head of the Bay of Fundy). 8. Windsor, N. S. (on the Avon River which flows into Minas Basin). At the above three stations the range of the tide is, as is well known, very great and the tide-gauges only registered the crests of the tidal waves. No secondary undulations are shown.

The records for the two points next noted are not from Tidal Survey gauges but from a portable recording tide-gauge of my own construction. Accounts of these have already been published.§

9. St. John River, N. B. (The station of observation was on a small bay in the mouth of the river, separated from the harbor by the narrow gorge, only 100 yards wide, through which the river rushes into the harbor.) There are two series of oscillations, one of a period between thirty and forty min-

* Sept. 27 (1); Oct. 7 (1), 8 (2), 9 (2), 12 (1), 21 (2), 31 (2); Nov. 6 (2), 16 (2) 18 (1), 22 (2); Dec. 4 (1), 5 (1), 6 (1)—1898.

† July 1 (t), 18 (4); Aug. 13 (8), 27 (11); Oct. 24 (9), 27 (5); Nov. 27 (6)—1898.

‡ Oct. 13 (5); Dec. 26 (7), 27 (4)—1898.

§ This Journal, iii, 1897. Trans. Nat. Hist. Soc. of New Brunswick, 1897.

utes, apparently identical with the oscillations shown by the official gauge in the harbor, the other a series of very rapid oscillations having a period of only 35 seconds.

1

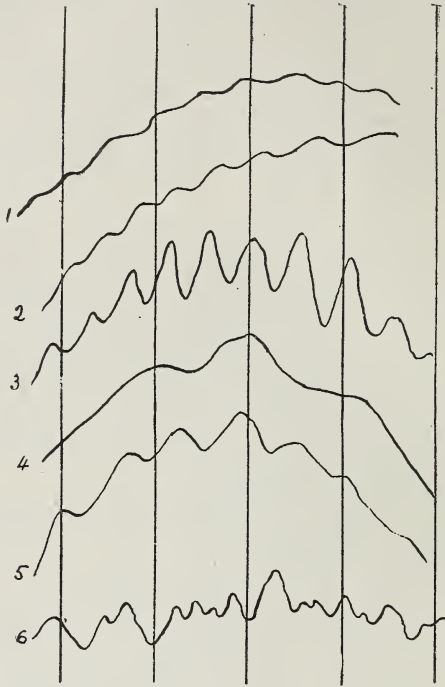

FIGURE 1.—Examples of regular secondary undulations. 1, Pictou; 2, Forteau Bay; 3, Yarmouth at low tide (examine with page inverted); 4, Yarmouth at high tide; 5, St. John; 6, Grindstone Island (as near an approach to regularity as could be found). The vertical scale is different for different curves.

10. Quaco, N. B. (about 20 miles farther up the Bay of Fundy than St. John). Three different records of secondary undulations were obtained, giving in all three cases a mean period of 12.5 m.

This completes the list of Bay of Fundy stations. Halifax is the only station not on either the Bay of Fundy or the Gulf of St. Lawrence, and may be next discussed.

Halifax, N. S. (on Halifax Harbor, Atlantic Coast of N. S.) Here secondary undulations are nearly always present through the whole range of the tide. Frequently they are very irregular and often of great amplitude, but to an eye accustomed to the curves representing the composition of simple harmonic

motions of different periods, the irregularity is at times markedly regular, showing the coexistence of at least two systems of undulations. As will be seen by fig. 2, the undulations at

2

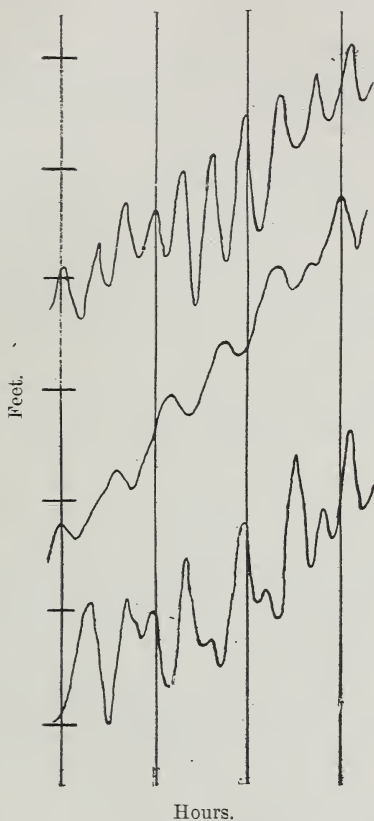

FIGURE 2.—Types of secondary undulations at Halifax, N. S.

times become simple and quite remarkably regular. At such times the period is either about 20 minutes or about 33 minutes. The figure shows both series and the apparent composition of the two in the third curve.

I pass now to a consideration of the records from stations on the Gulf of St. Lawrence and adjacent basins.

1. St. Paul's Island (in Cabot Strait between Newfoundland and Cape Breton, N. S. and connecting the Gulf of St. Lawrence with the Atlantic Ocean). The secondary undulations are here practically continuous and vary from fine shadings so

close together as to defy copying, to clear cases of a definite measurable period. Sometimes as many as 40 oscillations can be counted. The mean periods obtained are* 4·7 m., 4·8 m., 4·8 m., 4·65 m., 4·7 m., 4·7 m.—final mean 4·7 m. Along with these there occasionally occurs a series of much longer period depending apparently on a state of high wind. The period in such cases is difficult to determine accurately owing to the other markings referred to. The following exceptionally clear cases are of particular interest. On Oct. 15th, 1898, 11 regular oscillations gave a mean of 12·9 m. and on Oct. 16, 1898, 14 oscillations gave a mean of 12·9 m. In the latter case the amplitude was at times a foot and the whole tide was elevated $1\frac{1}{2}$ feet both at high water and at low water (a marked sign of high wind).

2. Souris, Prince Edward Island. Secondary undulations are almost always present. The extent is usually only one or two inches, at times three inches, occasionally swelling out to seven inches and showing strong signs of the coexistence of systems of different period. The only cases† in which the periods were definite and determinable gave 22·5, 21·8, 21·2, 21·2, 22·0, 21·6, 20·0, 22·4, 24·5 minutes—mean 21·9 minutes.

3. St. Peter's Bay, P. E. I. Secondary undulations are very common but usually very irregular. At times the irregularity shows evidence of the superposition of different systems. On a very few occasions‡ the undulations become regular, giving mean periods of 19, 22, 21 m.—final mean 20 m. On another occasion§ seven very regular oscillations gave a mean period of 30 m. pointing probably to the conflicting system. The gauge was only a month in operation.

4. Charlottetown, P. E. I. (on an irregular shallow bay connected by a narrow entrance with Northumberland Strait between P. E. I. and N. B.). Secondary undulations very rare and irregular.

5. Pictou, N. S. (at the eastern end of Northumberland Strait). Secondary undulations are frequent and persistent but of small extent; periods|| 33, 31, 26, 24, 30, 30, 28—mean 29 m. The preceding were from the records of a large gauge in the summer of 1896. In the following year a small gauge replaced the large one and periods¶ were observed of 26, 27, 32, 31 m.—mean 29 m. as before.

* July 4 (10), 3 (20); Oct. 3 (17), 1 (14); July 25 (40) Sept. 9 (7)—1893.

† July 8? (4), 17 (11); Aug. 17 (4), 24 (4), 29 (5), 29 (6); Sept. 20 (3), 19 (7), ? (4).

‡ Nov. 15 (5), 13 (4), 15 (10).

§ Nov. 16 (7).

|| Sept. 7 (5); Oct. 27 (6); Nov. 1 (6); June 20 (4); June 27 (3); June 30 (3); July 6 (5)—1896. (Occasionally some doubt as to exact date.)

¶ July 7 (10); Sept. 21 (5), 23 (5), 24 (8).

6. Cape Tormentine, N. B. (on the narrowest part of Northumberland Strait). Apparently no secondary undulations.

7. Lower Neguac, N. B. (at mouth of Miramichi Bay, where the gauge was placed "to obtain the open tide unaffected by the bars and rivers of the bay"). No evidence at all of secondary undulations.

8. Carleton, Quebec (on Chaleur Bay, a branch of the Gulf). Secondary undulations occur about once a week, but of such small extent and duration that no period can be deduced.

9. South West Point, Anticosti. Secondary undulations are almost incessant and frequently very irregular, but at times clear, regular, well sustained undulations occur:* 18, 18, 18, 19, 20, 18, 18, 18, 21, 20, 21—mean 19 m.

10. Grindstone Island (of the Magdalen Island group in the middle of the Gulf). Secondary undulations are nearly incessant but quite irregular and no clear period is found. (The data are perhaps insufficient as the gauge was only a short time in action.)

11. Forteau Bay (on the Strait of Belle Isle, between Newfoundland and Labrador). Secondary undulations are almost incessant, and usually very irregular. Rarely does a clear period emerge†: 17, 15, 16—mean 16m.

Résumé.

The secondary undulations at any place are at times irregular (rarely at St. John), at other times regular (perhaps never at Grindstone Island); when they are regular the period of oscillation has a distinct and characteristic value for each place, varying from place to place, from less than a minute to over an hour. The amplitude also varies widely. At some places at least two systems of regular oscillations of different periods are found; these may exist together (Halifax), or the period at low tide may be distinct from the period at high tide (Yarmouth).

Theories advanced to explain Secondary Undulations.

It will be convenient at this point to summarize the theories that have been offered to account for the preceding phenomena. There are two chief points that require explanation, the *origin* of the initial disturbance and the particular *period* (or periods) at each place. These two points may be entirely distinct or the explanation of one may include that of the other.

* Because of some slight difficulty in ascertaining exact dates I noted number of tidal sheet:—238 (7), 238 (12), 241 (8), 249 (5), 249 (5), 256 (25), 261 (8), 262 (9), 271 (5), 271 (5), 274 (5).

† These all occurred on Oct. 30-31, 1898.

(1). It has been supposed that the results are due in reality to peculiarities in the action of each tide gauge.—This suggestion hardly deserves serious consideration, and is only included here because it is so admirably disposed of by the case of Pictou (stated above), where two entirely different gauges in different years showed secondary undulations of the same mean period.

(2). Earthquake theory.—This also may be dismissed briefly. It could not account for the period nor for the fact that, in such a comparatively small area as the Gulf of St. Lawrence or the Bay of Fundy, some gauges always show secondary undulations, others never show any.

(3). "Seiche" theory.—Four years ago I advanced the suggestion* that the undulations were of the same nature as the "seiche" movements observed by Forel and others on the Swiss lakes, that is undulations of a partially confined body of water under the force of gravity, like the "wish-wash" of water in a bowl when disturbed. This explanation seemed to fit entirely the oscillations at St. John (both harbor and river), calculations from the soundings in the vicinity showing a remarkable agreement of calculated and observed period on the supposition that the oscillations were not of the fundamental or gravest mode (uninodal), but of the first higher mode (binodal). As will be seen later, it does not accord so well with other cases.

It is to be noted that the above theory is chiefly concerned with the *period* of undulation, leaving the initial disturbance of equilibrium to be accounted for by atmospheric conditions or by neighbouring oceanic disturbances invading the basin of oscillation.

(4). "Atmospheric billows" theory.—Mr. F. Napier Denison has advanced the interesting and ingenious theory † that "the secondary undulations are due to atmospheric waves or billows set up in the upper atmosphere" at the boundary between "the upper part of the lower stratum of air and the higher stratum which is less dense and rapidly moving polewards." To account for "how atmospheric waves, which correspond to only a few hundredths or thousandths of the barometric inch at the earth's surface, cause such rapid and extreme oscillations" of the water surface, Mr. Denison adds that "the atmospheric waves or billows, in passing over the

* This Journal, iii, 1897, where a full account of the bibliography of seiches will be found. In the paper here referred to, following the analogy of sound waves I used the word node (in binodal, trinodal, etc.), as meaning a place of minimum longitudinal motion. Finding it customary to use node in reference to vertical movement when speaking of water waves, I have changed the notation in the present paper.

† Articles already cited.

surface of the sea, tend to form minute undulations upon the surface, corresponding to the length of the billows, which, as they move farther into the bay, become magnified as they reach narrower and shallower portions." In a later paper Mr. Denison repeats the above views and states that "there is a marked relative correspondence in amplitude between the barometric and water undulations," adding many interesting speculations concerning a possible connection between secondary undulations and warm and cold waves, precipitation, etc., but we are not concerned with them at present. (It may be added that Mr. Denison's papers are very brief, containing but six pages in all and, excepting one case of secondary undulation at Halifax, giving no references in detail to the coincidences of barometric, meteorological and tidal records on which the theory is founded, so that, in again traversing the same ground, I was unable to refer directly to the evidence for the deductions.)

The above is primarily a theory of the *origin* of the disturbances. It would at first sight not seem incompatible with any other explanation of the period.

These theories will be tested in the sections that follow.

Comparison of observed and calculated periods.

In order to test how far the seiche theory, advanced for the cases at St. John, would apply in general, I calculated from the admiralty charts the width and mean depth of basins and channels immediately adjacent to several of the above mentioned stations and therefrom deduced the period in which such bodies of water should vibrate.

Station.	Basin or Channel.	Period observed.	Period calculated.	
			binodal.	uninodal.
St. John Harbor	Bay of Fundy	41 m.	43·5 m.	87 m.
St. John River	(small bay)	35 sec.	37·5 s.	72 s.
Westport	St. Margaret's Bay	16 m.	14 m.	28 m.
Yarmouth	N.S. to Lurcher Shoal	30 m., 69 m.	30 m.	60 m.
Souris	Northumberland Strait	21 m.	45 m.	90 m.
Farther Point	St. Lawrence River	21 m.	50 m.	100 m.
S.W. Point	Anticosti to Gaspé	19 m.	30 m.	60 m.
Forteau Bay	Strait of Belle Isle	16 m.	23 m.	47 m.

The above calculated periods can only be considered as roughly approximate. They suffice, however, to show that, except in the first four cases, the periods cannot be those of binodal seiches, and if they are seiche periods at all the seiches must be multinodal (e. g., at S.W. Pt. and Forteau Bay trinodal, at Farther Pt. quinque'nodal). Local peculiarities, for example variation in the depth of the basin, would,

of course, tend to set up partial vibrations (as would inequalities in the thickness of a cord.)

The above comparison then, while not at variance with the seiche theory, affords only partial confirmation of it. To other cases no calculation can be applied. Digby is on a basin of irregular form which may have somewhat regular vibrations, though theory is at present inadequate to calculate the period of such irregular bodies of water. The same is true of Halifax, with the peculiarity that the basin is one marked out by a series of banks (Roseway, Le Have, Emerald, &c.) which, while not coming to the surface, bound an irregular bay, attaining at places a depth of 300 fathoms. Pictou and Quaco are also on partially enclosed bays (reckoning the Quaco "ledges" as part of the boundary of the latter). At Grindstone Island (in the middle of the Gulf) and St. Peter's Bay (on the outer or Gulf side of P. E. I.) the undulations are always or nearly always irregular, as might be expected of points near the middle of such an irregular body of water as the Gulf of St. Lawrence.

The case of St. Paul's Island (at which there are periods of 4.7 and 12.9 m.) might be thought at first inexplicable, as the island is in Cabot strait between prominent headlands on either side, with no suggestion on an ordinary map of a channel or basin of oscillation. But a glance at the nautical chart (of 1891) shows that, while the main channel has a great depth (approaching 300 fathoms), on both sides of this channel, there is an abrupt change of depth and gradient and the contours of, say, 100 fathoms on opposite sides of this channel run roughly parallel for a distance greater than the width of the strait. Moreover, on the Cape Breton side and adjacent to St. Paul's Island, there is a depressed basin, only part of the boundary of which reaches the surface. Thus we have clearly the conditions for secondary undulations according to the "seiche" theory.

The case of Yarmouth presents a striking peculiarity. The seiche theory gives a very satisfactory account of the periods at Yarmouth; but why should the period at high tide be regularly twice as great as at low tide? The mere change in depth of the channel can have no such striking effect. The only other factor that changes with the state of the tide is the direction of the *tidal current*. I find myself unable to explain satisfactorily why the reversal of the current should have such a marked effect. A thorough examination and elucidation of this peculiar case might lead to a more satisfactory explanation of the whole subject than has yet been offered. It might also be noted that at St. Paul's Island the unusual elevation of water level at both high and low tide, on the

occasions on which the period shifts from 4·7 m to 12·9 m, would also mean some marked change in the currents through Cabot Strait.

Does the varying depth of the Bay of Fundy affect the period at St. John?

As stated in an earlier paper (already referred to), a conclusive test of the seiche theory would be the following. The period of oscillation of a body of water varies inversely as the square root of the mean depth. Now the mean depth of the Bay of Fundy at low water is something over 200 ft., and at high water (on the average) nearly 20 ft. greater. The width of the bay at St. John being about 40 miles, it can be calculated that the period of secondary undulation at St. John should, according to the seiche theory, be about 1·8 m. greater at low water than at high water.

To test this I selected 106 tracings of particularly well-marked secondary undulations at St. John. These I measured for period with the greatest care. Then I sorted them out into high tide undulations and low tide undulations, finding 49 of the former and 57 of the latter. The mean period for high tide was 40·5 m. and for low tide 41·7—a difference of 1·2 m. Now this was wholly confirmatory of the seiche theory. That the difference 1·2 should come out less than the calculated difference 1·8 is readily understood from the fact that the undulations nearly always continued before and after high and low tide, so that the effective difference of depth would be less than the mean range of the tide.

To test the probability of the above differences being mere chance, I calculated "the probable error" of each series, and found it to be the same—0·4 m. Now the mean of each series only differs from the mean of the whole by 0·6 m. From this it is a comparatively simple problem to calculate what is the probability that by mere chance the mean period at high tide was 0·6 m. higher than its real value and the mean value for low tide the same amount lower. The probability is $\frac{1}{13}$ or the chances are 12 to 1 against the difference being due to the mere chance distribution of somewhat rough determinations of what is really the same quantity.

Thus this test, while very strongly in favor of the seiche theory, is not conclusive.

Connections between undulations at different places.

Taking first points on the Atlantic and the adjacent Bay of Fundy, it is shown by a comparison of the records at Halifax, Yarmouth and St. John, that marked oscillations at one are

usually accompanied by marked oscillations at the other. Conspicuous examples are, Jan. 13th, 1898; Nov. 26 and 27, 1898; Dec. 23, 1898; Dec. 31, 1898; Jan. 1 and 2, 1899, &c. The exceptionally strong undulations on these dates coincided with severe storms from the south on the Atlantic. But this connection is not quite invariable, e. g., on Aug. 14, 1898, strong oscillations of 15 inches at Yarmouth were not accompanied by any exceptional oscillations at St. John or Halifax.

Turning now to a comparison of stations on the Atlantic and stations on the Gulf of St. Lawrence, it is found that in general no such connection exists. For instance, in my note book, opposite each of the cases of marked oscillations at St. John, Halifax, and Yarmouth, just enumerated, I have a note of the state of affairs at St. Paul's Island, South West-Point and Forteau Bay, and the notes, with two exceptions, are "no oscillations," "particularly slight," "less than normal," "only normal." In the two exceptional cases the note runs "above normal," and these two notes refer to St. Paul's Island, which, being in Cabot Strait, belongs as much to the Atlantic as to the Gulf.

The lack of connection here noted seems a point of such importance that I will illustrate it by another example. Pictou on the Gulf and Halifax on the Atlantic are on opposite sides of Nova Scotia and only about 100 miles apart, a much shorter distance than separates St. John and Halifax. The large tide gauge at Pictou was only maintained during the summer of 1896. I have compared the records from it with those from Halifax. In the following from my note-book the first note refers to Pictou, the second to Halifax:—July 3, "marked"—"normal"; July 17, "nothing"—"strong"; July 25, "nothing"—"strong"; Sept. 19, "nothing whatever"—"strong"; Sept. 20, "feeble"—"strong"; Sept. 24, "weak"—"strong"; Sept. 28, "strong"—"normal"; Nov. 1, "feeble"—"strong"; Nov. 11, "nothing"—"strong"; Nov. 14, "nothing"—"strong." These were, I believe, the only cases in which the undulations at either place were decidedly above normal and therefore suitable for founding such a comparison on. Thus there is no correspondence between the occurrences of secondary undulation at Halifax and Pictou.

Now, according to the theory of atmospheric billows, two points so comparatively close together as Halifax and Pictou should show a close correspondence of times of strong undulations; for it cannot be conceived that "atmospheric waves of from 15 to 30 kilometers long" whose "average velocity is 60 miles per hour in summer"* could raise strong secondary

* Denison, Proc. Can. Inst., Jan. 16, 1897, p. 30; Feb. 6, 1897, p. 58.

undulations at Halifax and fail to affect Pictou and *vice versa*. This discrepancy is still more marked when it is considered that Pictou is almost exactly N.E. from Halifax, and it is on the poleward current, moving N.E., that Mr. Denison relies for the production of the atmospheric billows in question. (It is to be understood here that I am not discussing the existence of atmospheric billows but the effects attributed to them.)

On the other hand, the close correspondence between Atlantic (including Bay of Fundy) ports, in contrast with the lack of correspondence between Atlantic and Gulf ports, is strongly in favor of the view that the disturbance at any port is usually due to the transmission by water of distant disturbances of the general body of water caused by storms.

Secondary Undulations and barometric records.

Any connection between atmospheric disturbance and secondary undulation should, of course, be shown by a comparison of tidal and barometric records. I have carefully compared the tracings of secondary undulation at St. John for the summer of 1896 with tracings of the St. John barograms for the same date. These latter I owe to the kindness of Mr. Bell Dawson. They were made as carefully as possible with a hard, sharp-pointed pencil. The dates are June 8, 9, 10, 21, 22, 23; July 8, 25; Sept. 1, 5, 6, 7, 18, 19, 20, 22, 23—the only occasions, I believe, on which marked secondary undulations occurred at St. John during the summer of 1896. A careful comparison of both series of records shows that (1) disturbances of atmospheric pressure usually occur about the times of secondary undulations, and, in general, the stronger the atmospheric disturbances the stronger the water undulations, but (2) the atmospheric disturbances rarely if ever begin and end at the same time as the water undulations; they usually precede but sometimes seem to follow the latter, and the secondary undulations may continue for several hours (e. g. 12 hours on Sept. 20) after the barometric disturbances have ceased; (3) in no case is there any suggestion of regular periodicity in the barometric disturbances such as there is in the water undulations.

The utmost therefore that it seems to me possible to deduce is that secondary undulations usually accompany storms near by or at a distance, but that the *period* of the oscillations at any place is wholly unaccounted for by atmospheric conditions. (This is also in accord with an extensive series of comparisons that I made, of the Atlantic Pilot Charts and the Canadian Weather Maps on the one hand and the records of secondary undulations on the other—into the details of which it seems superfluous to enter.)

Mr. Denison, however, states as the first of the ten "chief points deduced" by him (but without any indication of the details of the evidence), "that the undulations are due to the direct action of atmospheric waves upon the surface of the water *at stations* [italics mine] and not to ground swells, due to distant storms, or 'seiche' movements, as found upon lakes during atmospheric disturbances." Now with the former or positive part of this conclusion the evidence I have adduced above does not seem at all compatible; the latter or negative part, denying any other agency, can only mean the sufficiency of the theory of atmospheric waves to account for the *period* as well as the *origin* of the secondary undulations, which again is wholly at variance with the fact that the barometric disturbances show no periodicity and the water undulations continue regular and periodic after the barometric record has become quite smooth. The second point enumerated by Mr. Denison is that "there is a marked relative correspondence in amplitude between the barometric and water undulations." This I also have found to be the case, provided it be not understood to imply that the two kinds of undulations always (or even usually) occur or continue at the same time. (I would also take some exception to the word "marked.")

From the above statements in Mr. Denison's paper it has been inferred by some readers that he found regular atmospheric oscillations coinciding with and accounting for the water undulations both as regards origin and period. Mr. Denison does not directly say so and this cannot be his meaning. There is absolutely no evidence for it in the cases I have referred to above, covering a whole summer of St. John records. How in fact is it conceivable that atmospheric billows many miles in length and moving with a velocity of from 60 to 112 miles per hour, should always have a periodicity of half a minute at the mouth of the St. John River—41 m. at St. John Harbour (less than a mile away)—12½ m. at Quaco (20 miles away)—69 m. at Yarmouth at high tide, but 30 m. at low tide—20 m. at Halifax on some occasions, but 33 m. on other occasions and occasionally probably both—47 m. at St. Paul's Island—29 m. at Picton, etc.?

Effect of Contraction of Bay.

Reference must be made to another point in the "atmospheric billows" theory. To account for such slight variations of pressure causing such large variations of water level, it is necessary to suppose that, as in the case of ordinary tides, "minute undulations as they move farther into the bay become magnified as they reach narrower and shallower portions."

Yet, if we consider the Bay of Fundy, exactly the opposite is true. Yarmouth is at the mouth of the bay and there the oscillations sometimes reach 5 ft.; St. John is half way up the bay and there the oscillations never exceed 2 ft.; while at the head of the bay, where, as is well known, the rise of the tide is enormous, Hopewell Cape, Parrsboro and Windsor show no secondary undulations. Again Carleton, Q., is at the head of Chaleurs Bay, but the undulations there are particularly slight. At Cape Tormentine, which is in the narrowest part of Northumberland Strait, there are no secondary undulations and the same is true of Charlottetown, while they are very frequent at Pictou and Souris near the entrance of the Strait.

On the other hand, it is to be noted that, according to the seiche theory, secondary undulations would not be expected in shallow basins such as those at the head of the Bay of Fundy; since, if oscillations of the whole body of water were started, they would rapidly die away in such shallow water.

On the whole, the theory of "atmospheric billows," while ingenious and attractive, seems to me wholly untenable as regards the *period* of undulation and very improbable as regards the *origin* of such undulations (I am not of course referring to the agency of atmospheric disturbances in general), whereas the "seiche" theory offers the only tenable explanation hitherto advanced, but leaves points still unexplained.

A general view of the vibrations of large bodies of water.

It may be well at this stage to make explicit a general view implied in the preceding discussion. It seems probable that a large body of water, such as the Gulf of St. Lawrence or the Bay of Fundy, when disturbed breaks up into smaller areas of oscillation, determined by irregularities in the level of the bed; these minor basins oscillate to a considerable extent independently, at rates determined by their respective dimensions and the depth to which they are filled, the oscillations being at times in the fundamental mode, but at other times in some higher mode, but with a tendency to the establishment of some particular mode that gives a characteristic period to the basin. Frequently, owing to the co-existence of different modes of vibration, and owing to invasions from the vibrations of neighboring basins, the vibrations of each minor basin become more or less irregular; but such irregularities are comparatively rare in a part of the main basin with only slight irregularities of bottom and bounded on opposite sides by nearly parallel coasts (as is the case of the Bay of Fundy at St. John, where the records show a more constant period of undulation than at any other tidal station on the eastern coast of Canada).

Another possible source of periodic fluctuations under certain circumstances.

Can any other explanation be found for the definite period that characterizes the regular undulations at each place? I can think of but one other.

Most people who have, from the shore, watched the progress of a ship have noticed the regular series of waves thrown off from the bow. If the ship be at anchor in a rapid current, a similar series of waves are produced, reaching any point on the shore at equal intervals. In general it may be stated that "a line of pressure athwart a stream flowing with velocity c produces a disturbance consisting of a train of waves of length $2\pi c^2/g$ lying on the down-stream side."* The effect of inequalities in the bed would be similar. Would an island, shoal, bank or headland, past which a current is setting, cause a similar series of waves of a length and period commensurate with the size of the obstruction? For example, St. Paul's Island divides two opposite currents between the Atlantic and the Gulf of St. Lawrence; at Yarmouth the direction of the tidal current is reversed with the tide and the Lurcher shoal is a prominent obstruction.

I do not attempt to consider this suggestion in detail. It seems to me a much less likely explanation than the theory of stationary undulations or seiches; but no adequate attempt, in a brief space, to test its applicability would be possible, even if data as regards currents, etc., were to be had.†

Summary of preceding.

A. FACTS.

1. Secondary undulations occur at most of the places where observations have been made, the undulations at any place being sometimes irregular but at other times of a regular periodic nature.

2. When the undulations are regular, the period of undulation has a distinct and characteristic value for each place, varying, from place to place, from less than a minute to over an hour.

3. At some places at least two systems of regular periodic undulations of different periods are found; they usually occur

* Lamb's *Hydrodynamics*, § 228, where illustrations of such waves from experimental papers by W. and R. E. Froude and theoretical papers by Lord Kelvin and Lord Rayleigh are given.

† Moreover, in making this somewhat vague suggestion, I am aware that the formula quoted above for the length of such waves is independent of the size of the obstruction: but this does not preclude the possibility that hydrodynamical theory, applied to the case of very large obstructions, might be able to account for all the phenomena.

at different times, sometimes they occur together; at one station the period at high tide is entirely distinct from that at low tide.

4. Undulations usually occur simultaneously at stations on the Atlantic Ocean (including the Bay of Fundy), but there is apparently no connection between this occurrence at stations on the Atlantic and stations on the Gulf of St. Lawrence.

5. Barometric records show no similar periodic oscillations, but they do show disturbances at or about the times of marked secondary undulations.

6. As the head of a bay is approached secondary undulations do not become more marked and frequent, but apparently less.

7. According to the best available evidence the period at St. John is less the greater the depth to which the tide fills the Bay of Fundy.

B. DEDUCTIONS.

1. The theory of atmospheric billows does not and cannot explain the characteristic local *period* of secondary undulations.

2. As an explanation of the *origin* of secondary undulations the theory of atmospheric billows seems at variance with certain facts of fundamental importance to the theory (see 4 and 6 under A, above).

3. The seiche theory, which is fully established in the case of lakes, has a high inherent probability and is not at variance with any ascertained facts and in certain respects receives strong confirmation (see 2, first part of 3, 4, 6, and 7, under A, above).

4. Even if the "seiche" theory be correct, it still remains to be explained why the oscillations at certain places are usually binodal, at others trinodal, etc., and why in one striking case (Yarmouth) the oscillations are always uninodal at high tide and binodal at low tide.

5. The whole subject is apparently much more complex than has hitherto been supposed and it may yet be found that no single explanation will apply to all cases.

ART. XIV.—*Mathematical Notes to Rival Theories of Cosmogony*; by O. FISHER.

THE following mathematical notes are supplementary to the discussion of "Rival Theories of Cosmogony" in the June number of this Journal (pp. 414–422).*

Let—

- r = distance of any point from the earth's center.
 a = the earth's mean radius in feet.
 $\log a = 7.3201961$.
 $qa = 2.4605$ in radians = $140^\circ 58' 35''$.
 s = the density of the surface rock (2.75).
 gs = the weight of a cubic foot of the same, viz: 171.875 pounds.
 ρ = the density at any depth.
 p = the pressure in pounds per square foot at the depth where the density is ρ .
 c = the coefficient of compressibility at that depth measured by atmospheres.
 J = Joule's equivalent, 772.
 σ = specific heat of rock.

$$(1) \text{ Laplace's law of density is, } \rho = Q \frac{\sin qr}{r},$$

where Qq is the density at the center, 10.74 ,
 and $qa = 2.4605$ in radians = $140^\circ 58' 35''$.

(2) The relation upon which the following calculations depend is one which I have proved in the Appendix to my "Physics of the Earth's Crust" (p. 32), viz:

$$p = \frac{gs}{2s^2} \frac{a}{1 - qa \cot qa} (\rho^2 - s^2);$$

$$= B(\rho^2 - s^2), \text{ suppose,}$$

which, reduced to numbers, gives for the relation between the pressure measured in pounds per square foot and the density,

$$p = 5.8855 \times 10^7 \{ \rho^2 - (2.75)^2 \}.$$

Hence we see what is the value of the constant B , which is implied in Laplace's law of density, viz: 5.8855×10^7 in the above units.

Also since
$$cp = \frac{\rho - s}{\rho} \text{ or } c = \frac{1}{p} \frac{\rho - s}{\rho},$$

* Attention is called to the following *erratum*: On p. 421, for 20 miles read 40 miles.

we get for the compressibility in pounds per square foot,

$$1.699 \times 10^{-8} \frac{\rho + s}{\rho},$$

which reduced to atmospheric pressure is

$$c = 3.6069 \times 10^{-8} \frac{\rho + s}{\rho}.$$

(3) The above relation between the pressure and the density renders it easy to calculate the work of compression, and thence the temperature;

for
$$work = -\int_{v_0}^v p dv,$$

where
$$p = B (\rho^2 - s^2).$$

And since
$$\frac{v}{v_0} = \frac{s}{\rho},$$

$$\therefore dv = -v_0 s \frac{d\rho}{\rho^2};$$

and
$$\begin{aligned} work &= v_0 s \times 5.8855 \times 10^7 \int_s^\rho (\rho^2 - s^2) \frac{d\rho}{\rho^2} \\ &= v_0 s \times 5.8855 \times 10^7 \left(\rho + \frac{s^2}{\rho} - 2s \right) \\ &= v_0 s \times 5.8855 \times 10^7 \frac{(\rho - s)^2}{\rho}. \end{aligned}$$

And the temperature =
$$\frac{work}{J \times specific\ heat \times mass}$$

Mallet's value for the specific heat of rock is 0.199. The mass will be $s \times v_0$, which will divide out, and thus

$$temperature\ Fah. = \frac{B}{J\sigma} \frac{(\rho - s)^2}{\rho}.*$$

This will give the temperature so long as we can reckon upon the specific heat remaining constant, which probably will not be the case for the higher temperatures, and certainly not so if the substance becomes liquid or gaseous, when the latent heats will disappear, but it will be sufficient to show what enormous temperatures such condensation would produce, even if the specific heat should be as great as that of water.

* The log of the coefficient $\frac{B}{J\sigma}$ is 5.5833156.

(4) The lava issued from Etna at 1932° Fah. We can find the depth at which that temperature would have been produced by compression of surface rock.

$$\text{We have} \quad \text{temperature Fah.} = \frac{B}{J\sigma} \frac{(\rho - s)^2}{\rho}.$$

Applying this to the present case, we get

$$\frac{(\rho - s)^2}{\rho} = 5.043 \times 10^{-4} = 2m, \text{ suppose,}$$

$$\text{whence} \quad \rho - s = m \pm \sqrt{(s + m)^2 - s^2}.$$

Since the surd is greater than m and $(\rho - s)$ must be positive, we must use the upper sign; we then obtain

$$\rho - s = 0.120.$$

This will be the increase of density to the depth where the temperature is 1932° Fah. or $\rho = 2.87$.

We then require the value of r which will make

$$Q \frac{\sin qr}{r} = 2.87.$$

It appears on trial that a depth $a - r$ of about 40 miles satisfies this condition. It follows that the depth at which the temperature 1932° Fah. would be produced would be about 40 miles.

TABLE.

Tenths of radius.	Approximate depth in miles.	Densities by Laplace's Law.	Pressure in atmospheres.	Condensation $\frac{v_0 - v}{v_0}$ requisite to reduce surface rock to density.
1.0	0	2.75	0.000	0.000
0.9	400	3.88	2.181×10^7	0.29
0.8	800	5.03	5.055×10^7	0.45
0.7	1200	6.17	8.460×10^7	0.55
0.6	1600	7.25	12.344×10^7	0.62
0.5	2000	8.23	16.867×10^7	0.67
0.4	2400	9.09	20.698×10^7	0.70
0.3	2800	9.80	24.370×10^7	0.72
0.2	3200	10.32	27.030×10^7	0.73
0.1	3600	10.64	29.052×10^7	0.741
0.0	4000	10.74	30.061×10^7	0.744

ART. XV.—*Studies of Eocene Mammalia in the Marsh Collection, Peabody Museum*; by J. L. WORTMAN.

[Continued from vol. xi, p. 450.]

Family Viverravidæ.

Miacidæ Cope (in part), Tertiary Vertebrata, 1884; *Miacidæ* Scott, Jour. Acad. Nat. Sci., Phila., 1886, vol. ix, p. 169; *Viverravidæ* Wortman and Matthew, Bull. Amer. Mus. Nat. Hist., 1899, p. 136.

A FAMILY of small or medium-sized Carnassidents ancestral to the viverrines, ranging in time, as far as at present known, from the Torrejon to the Bridger Eocene, having pentadactyle limbs with ununited scaphoid, lunar, and centrale of the carpus, a civet-like perforation of the transverse process of the atlas for the passage of the vertebral artery, a well-developed anterior basal cusp upon the superior sectorial, no antero-posterior femoral curvature and no postero-internal cingular cusp upon the superior molars. Blades of the superior sectorial separated by a deep slit-like notch, and molar formula either $\frac{3}{3}$ as in the primitive Canidæ, or $\frac{2}{2}$ as in the Viverridæ.

In defining the foregoing family, it is necessary to distinguish it from the contemporary Canidæ on the one hand and its successors, the Viverridæ, on the other. As regards the former, while in all probability they have been derived from a common source, yet they have departed sufficiently in the direction of their subsequent and final development to be recognizable. There are two characters that appear to be entirely distinctive, one of which relates to the atlas and the other to the presence or absence of an anterior basal cusp on the superior sectorial; associated with these is the lack of curvature of the femur and no disposition whatever towards the formation of a postero-internal cingular cusp on the superior molars,—features which have characterized all lines of Canidæ in some stage of their development. From the Viverridæ, they can be distinguished not by any essential characters of fundamental importance, but only by the possession of such primitive and archaic features as we should reasonably expect to find in the ancestors of the modern viverrines. The more important of these relate to the separate condition of the scaphoid, lunar, and centrale of the carpus; the presence of a third trochanter on the femur; the large size and internal position of the lesser trochanter; the slight grooving of the astragalus, and the large size of the deltoid crest of the humerus. To this may be added the greatly inflated and modernized condition of the otic bulla in the living Viverridæ.

From the Mustelidæ, as far as at present known, the Viver-

ravidæ are distinguished not only by the possession of the primitive characters above enumerated, but by two very trenchant dental peculiarities which the mustelines exhibit, viz.: the great antero-posterior enlargement of the internal portions of the crowns of the superior molars, and the absence of the deep slit-like notch separating the two blades of the superior sectorial. These, together with the absence of the anterior basal cusp on the superior sectorial, the great breadth of the base of the skull, the small rugged bulla, and long bony spout-like meatus, constitute the real distinguishing features by which the Mustelidæ may be separated from the Viverridæ. The skeletal characters are otherwise much alike in the two families, the manner of perforation of the transverse process of the atlas being variable in the mustelines.

With reference to the Felidæ, it may be said that our knowledge is not so perfect regarding their origin and Eocene representatives as it is with respect to other living families, so that it is well nigh impossible to make a satisfactory comparison. If the Palæonictidæ are the forerunners of the felines, which seems so exceedingly probable, then the two groups belong to different phyla and may be distinguished by the structure of the superior molars. In the Palæonictidæ, it is the posterior part of the crown of the first superior molar which is elongate; whereas in the Viverravidæ, it is always the anterior part of the crown which is the longer.

Viverravus Marsh.

Viverra, a civet cat; and *avus*, a grandfather. This Journal, August, 1872; *Didymictis* Cope, Tertiary Vertebrata, 1884; *Viverravus* Wortman and Matthew, Bull. Amer. Mus. Nat. Hist., 1899, p. 136.

A group of small or medium-sized civet-like Carnivores, with a number of species distributed throughout the Eocene from the Torrejon to the Bridger inclusive. They are characterized by having the dental formula I. $\frac{3}{3}$, C. $\frac{1}{1}$, Pm. $\frac{4}{4}$, M. $\frac{2}{2}$, of which the two superior molars of the dentition have broad tubercular crowns, with great transverse extension of the anterior border, the two external cusps being unequal and placed well inwards from the external margin of the crown; the second inferior molar, tubercular or becoming so, and much smaller than the first; the inferior sectorial having a high trigon, with oblique principal shear, a well-developed posterior shear, and a relatively large, more or less basin-shaped heel; and premolars having posterior accessory cusps.

In his original description of this genus, Professor Marsh says: "A much smaller Carnivore, about the size of the mink, is represented in our collections by two lower jaws with teeth, and a sectorial upper molar of one individual and portions

apparently of several others. The lower jaws in this genus are long, slender and compressed; the last two lower molars are tubercular. Both have the posterior part of the crown quite low and the anterior half elevated and composed of three angular cusps. The four teeth anterior to these are much compressed. The upper flesh tooth closely resembles that in some of the Viverridæ and the genus should probably be referred to that group."* The species thus far referable to this genus are numerous, of which one, *V. haydenianus*, from the Torrejon; four, *V. leptomytus*, *protenus*, *massefericus*, and *curtidens*, from the Wasatch; and two, *V. gracilis* (*dawkinsianus*) and *altidens*, from the Wind River beds, have been described by Cope. It will thus be seen that the genus has a very great vertical range, greater, in fact, than any known contemporary group of mammals throughout the whole Eocene. With the close of the Bridger epoch, according to our present knowledge, the genus disappeared from this country, since no remains of it have as yet been found either in the Uinta, White River, or John Day deposits.† It is possible, however, that the group may have continued to exist to a much later date on this continent, and that they retreated to the southward along with the tropical fauna which disappeared from Wyoming at the close of the Eocene. It is possible, therefore, that their remains will yet be found in the Miocene of the South, but this, of course, is merely conjectural.

Viverravus gracilis Marsh.

Didymictis dawkinsianus Cope, Tertiary Vertebrata, 1884, p. 310.

The type, figures 18, 19, consists, as Professor Marsh has stated, of parts of both mandibular rami and a superior sectorial, but there are at least twenty individuals of the species represented in the collection by various fragments. Of the type the right ramus is the more perfect of the two, and carries the third and fourth premolars and the first and second molars. The alveoli for the first and second premolars, together with that for the root of the canine, are represented. All the premolars are two-rooted, even the first, which among the Carnivora is very generally a single-rooted tooth. The third and fourth premolars have high pointed crowns, with anterior and posterior basal cusps, together with a distinct and trenchant accessory cusp. The sectorial has the trigon much elevated

* Loc. cit., p. 7, of separata.

† A possible exception to this statement may be found in the imperfectly known genus *Bunaelurus* of Cope, from the White River Oligocene of Colorado. When more fully known, it will not be at all surprising to find that this genus is a direct descendant of *Viverravus*.

and of greater antero-posterior length than the heel; the anterior and internal cusps are equal in height, but the external was evidently much higher; it is somewhat damaged and does not display its full length. The principal shear is oblique, and there is a posterior shear which bites against the anterior edge of the first molar. The heel is relatively short, wide, and basin-shaped; the external part of the basin is the thicker and more elevated. The second molar is much smaller than the first, but displays practically the same structure; the trigon, however, is much less elevated, and the shears are imperfect. The external and internal cusps are of equal size and height, but the anterior is much smaller and lower. The heel is relatively longer than in the first molar, being obtusely pointed behind, where it is terminated by a low but distinct cusp; from this cusp a low ridge is continued forwards and inwards to enclose the inner

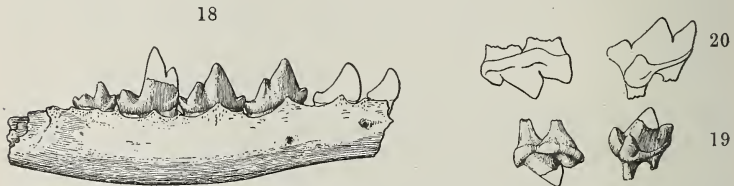

FIGURE 18.—Right lower jaw of *Viverravus gracilis* Marsh; outside view; natural size. (Type.)

FIGURE 19.—Superior sectorial of same; outside and inside views; natural size. (Type.)

FIGURE 20.—Superior sectorial of *Viverricula* sp.; natural size.

part of the basin. Externally there is a stronger cusp situated in advance and to the outer side of the last mentioned cusp, which furnishes the external boundary of the basin.

The superior sectorial displays the typical laniary structure of the more highly-developed Carnassidents; it is composed of a pair of external cusps, laterally flattened and elongated in such a manner as to form a pair of very effective shearing blades. Of these, the anterior is the larger and more elevated, being separated from the posterior by a deep vertical notch, which appears as a narrow slit upon the lingual surface. At the antero-external angle of the larger cusp is seen a lower, but very distinct, anterior basal tubercle. Internal and opposite to the anterior edge of the main external blade is placed a relatively large, pointed internal cusp of about the same proportions of that of the Genet. In fact, the whole dentition, as far as known, is strikingly like that of this living species.

In his description of *V. dawkinsianus*, Professor Cope states that the first premolar of the inferior series is a single-rooted tooth. If this is true (which I am inclined to doubt), the two

species are distinct and we have the anomalous condition of the latest known species of the genus being less specialized in this particular than its immediate predecessor. The species is distinguished from all the others by its small size and the short broad heel of the lower sectorial. The principal measurements of the type are as follows :

Length of inferior molars and premolars	28· mm
Length of inferior molars	9·5
Length of sectorial	5·2
Transverse diameter of sectorial	3·4
Antero-posterior diameter of superior sectorial,	7·
Transverse diameter of superior sectorial	3·5

The type specimen was found at Grizzly Buttes, by G. G. Lobdell; other specimens were obtained at various levels from the upper to the lower part of the horizon.

Viverravus minutus sp. nov.

This species is represented in the collection by remains of at least six individuals, of which the lower jaws alone, in varying degrees of completeness, are preserved. That which is here

21

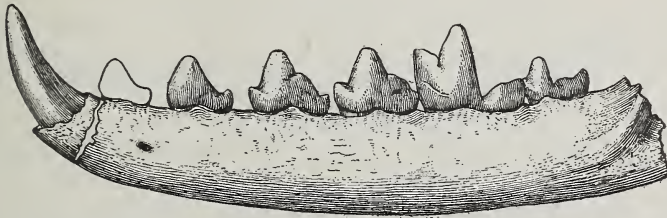

FIGURE 21.—Left lower jaw of *Viverravus minutus* Wortman; outside view; three times natural size. (Type.)

selected as the principal type, figure 21, is a left ramus carrying the molars and the three posterior premolars in good preservation. The specimen in question is broken just posterior to the base of the coronoid and also in front in the region of the symphysis, but it includes the base of the canine alveolus as well as that for the first premolar. The crowns of the molars are somewhat worn, so as not to display very clearly the character of the cusps of the heels. On this account, I associate with it another specimen as a cotype, also a left mandibular ramus of the left side, in which the heels of these teeth are more perfectly preserved. A third fragment of a jaw carries the canine in perfect condition.

The character of the species, as exhibited by these three specimens, may be stated as follows: It is considerably smaller than *V. gracilis*; the first premolar is two-rooted; the third and fourth premolars have anterior and posterior basal cusps and posterior accessory cusps which are absent on the second; the heel of the sectorial is proportionally narrower, and not quite so distinctly basin-shaped, as in *V. gracilis*. The last molar has a distinctly narrower, more trenchant heel and does not exhibit the two cusps seen in *V. gracilis*. The canine is long, slender, and considerably recurved. The remains indicate an animal of the size of the common weasel, the slender jaws and sharp cutting teeth giving evidence of a very highly carnivorous habit.

Length of inferior molars and premolars	21· mm
Length of inferior molars	7·
Length of first molar	4·5
Width of first molar	2·5
Depth of jaw at interior sectorial	4·5

The principal type specimen was found on Dry Creek, Bridger Basin, by Messrs. Lamothe and Chew, although other specimens are from Grizzly Buttes.

Oödetes herpestoides gen. et sp. nov.

Oön, an egg; and *detes*, a biter, in allusion to the habits of the Ichneumon.

A genus of small viverrine-like animals, having the dental formula I. $\frac{3}{3}$, C. $\frac{1}{1}$, Pm. $\frac{4}{4}$, M. $\frac{3}{3}$, with trigon of inferior molars high, the cusps sub-equal, and the principal inferior shear high and very oblique; inferior molars with trenchant or slightly basin-shaped heels; transversely extended superior molars, with tubercular crowns; anterior and posterior external angles of first molar about equally extended, and antero-external angle of second more extended than posterior; a superior sectorial, with sharp blade-like principal cusps, and premolars without posterior accessory cusps.

The remains upon which this genus and species are founded consist of the larger part of the skeleton of one individual, considerably broken, but at the same time with nearly all the characteristic portions represented. I associate with this type two other individuals, one of which is represented by a left lower jaw, broken away at the base of the coronoid, but containing all the teeth, with the exception of the incisors, in a state of good preservation; the third specimen is the posterior portion of a left mandibular ramus of an immature individual, in which the fourth premolar was just coming into position.

Dentition.—With the exception of a single isolated tooth which apparently belongs to the upper series, the incisors are not preserved in any of the three specimens, but the bases of the alveoli for those of the lower jaw can be indistinctly made out. They were three in number and arranged apparently as in the *Paradoxures*, without having the second one pushed back out of line, as is frequently found in the *Canidæ* and some *Viverridæ*. The canine, figure 22, is relatively large, high, pointed, and recurved; there is a faint vertical external groove, and a broader shallow one upon the internal face of the crown; on the posterior and external surface is an extensive worn area, where the tooth impinged upon its fellow of the upper series.

22

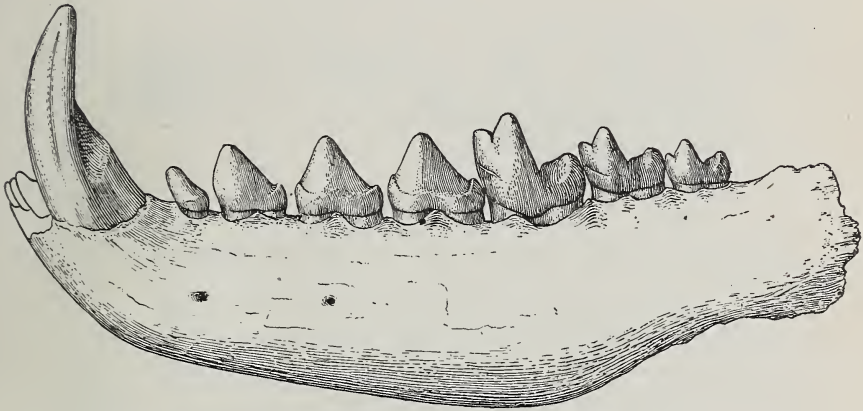

FIGURE 22 —Left lower jaw of *Oodectes herpestoides* Wortman; outside view; three times natural size. (Cotype.)

The premolars are four in number, with rather short, stout, thick crowns, having more or less of a tendency towards the development of strong internal cingula and cusps as seen both in the *Paradoxures* and *Herpestinæ*. The first is small, single-rooted, with an obtusely-pointed crown directed well forwards like the corresponding tooth in *Herpestes griseus*, and separated from the canine by a short interval. The second is abruptly larger, two-rooted, and has a small, indistinct posterior basal cusp. The third and fourth are still larger; their crowns are relatively thick, with obtuse points and inconspicuous anterior and posterior basal cusps; there are no posterior accessory cusps present, except a slight indication of one in the last premolar, as in *Herpestes*, to which the series of teeth, including the canine, bears a very striking resemblance.

The molars show many peculiarities for a Carnivore, and at first glance might indeed be readily mistaken for an Insecti-

vore; but a careful examination clearly reveals their carnivorous character. As is usual among the Carnassidents, the first molar is the largest of the series, which decreases in size posteriorly. Where the full number is present, it is a very general rule that the first greatly exceeds the second in size; but in the present case the decrease is much more gradual. The crowns have the anterior part much elevated and divided

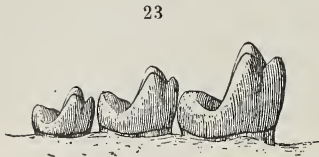

FIGURE 23.—Lower molars of *Oödectes herpestoides* Wortman; inside view; three times natural size. (Cotype.)

into the three usual cusps. Instead, however, of the external one being much larger and higher than the other two, they are more nearly equal (figure 23). They are placed at the points of a triangle whose sides are sub-equal, the shortest side, or base, being directed inwards and a little forwards. Between the outer and anterior cusps a short more

or less imperfect shear is developed, and a posterior shear is also present between the outer and inner cusps. The heel is composed of a central fore and aft secant ridge, on the inner side of which the border is slightly raised, thus giving the first step in the formation of the basin-shaped talon. The succeeding teeth are alike in structure, with the exception that the principal shear is proportionately less developed on account of the reduction in size of the anterior cusp of the trigon.

Of the superior dentition, figure 24, the single incisor, if it is correctly referred to this category, has a rather narrow, pointed crown, somewhat flattened upon its posterior surface, and corresponds most nearly with the second. The canine resembles that of the lower jaw, showing about an equal degree of stoutness and curvature. The first premolar is not preserved in any of the specimens. The second has an obtusely-pointed crown, with a small posterior basal cusp and an indistinct cingulum upon the inner margin of its base. The third is thicker, somewhat triangular in cross-section, with a more pronounced posterior basal cusp and a stronger internal cingulum. In many of the viverrines, more particularly the Herpestine and Paradoxurine sections, the third premolar has a tendency to develop an internal cusp, and the formation of the internal cingulum may be regarded as the initial stage in this process.

At first sight it would appear that the fourth superior premolar is of a too highly developed sectorial character to correspond with that of the lower jaw; but, curious as this may seem, there can be no possible doubt of the association. This tooth, however, betrays its primitive character in the large size

of its antero-external cusp, which is relatively high and conical, with its posterior portion little drawn out into a cutting surface. The posterior cusp is sharp and blade-like, but proportionally small. The two are separated by the usual vertical fissure. There is a distinct anterior basal cusp, which has an unusually external position. The presence of this cusp is a very constant feature of the viverrines, and its external position recalls the Herpestine section of the family. The internal cusp is of only moderate proportions and is placed well forwards, as in the civets in general.

The first molar is symmetrical in respect to the extension of the external angles; they are both equally extended and the two sub-equal external cusps are placed well inwards from the

24

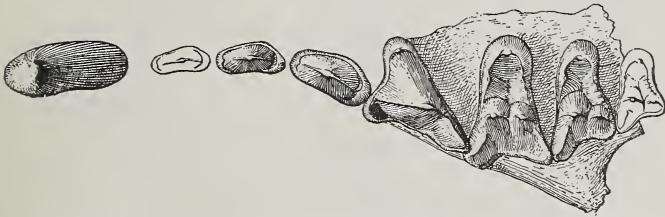

FIGURE 24.—Right upper jaw of *Oödictes herpestoides* Wortman; crown view; three times natural size. (Type.)

crown margin. The internal cusp is large and lunate, and there is a well-developed anterior and a very faint posterior intermediate cusp. The second molar has the antero-external angle well extended, but the posterior is short; with the exception of this difference its structure is very like that of the first. The third molar is not preserved, but the alveoli indicate not only its existence but its goodly size as well.

Vertebrae.—While the vertebral column is by no means complete, yet a number of the vertebræ are preserved and serve to give some idea of this part of the skeleton. A portion of the atlas, figure 25, shows that the perforations for the vertebral artery are the same as those in the civets. The body of the axis is rather long, sharply keeled below, and there is a well-developed peg-like odontoid process. The bodies of the remaining cervicals are short, depressed, and keeled; they are smaller in proportion to the size of the lumbers than in any of the living civets. The lumbers increase in size

25



FIGURE 25.—Portion of atlas of *Oödictes herpestoides* Wortman; top view; three halves natural size. (Type.)

progressively backwards, showing elongated inferiorly keeled centra. The third lumbar, figure 26, has a spine of moderate

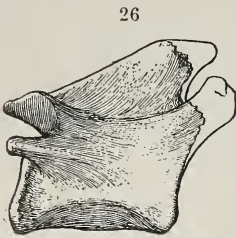

FIGURE 26.—Third lumbar vertebra of *Ooedectes herpestoides* Wortman; side view; three halves natural size. (Type.)

height, and simple, cylindrical posterior, and hollow, half cylinder-like anterior zygapophyses, and distinct anapophyses and metapophyses. There is apparently no trace of the double tongue and groove pattern of certain of the contemporary Creodonts. The sacrum is composed of three ankylosed vertebrae, and there was a long and powerful tail.

Fore limb.—The scapula is represented by the proximal end in a damaged condition. The glenoid cavity is elliptical and cup-shaped; the neck is very short, the unusually heavy spine rises close to the glenoid border, as in the Binturong, and there was a prominent metacromion present.

The humerus, figure 27, is complete, but considerably crushed laterally; it exhibits the following characters: The head is well rounded, pyriform, and overhangs the axis of the shaft posteriorly; the greater tuberosity is inconspicuous, and does not reach the level of the head; the deltoid crest is large and extends well down the shaft; the distal extremity is broad, with large supinator ridge and internal condyle, and there is an entepicondylar foramen.

In its proximal portion, the ulna, figure 29, exhibits some peculiarities of structure to which that of the Binturong makes a very decided approach. The chief peculiarity is seen in the upward curvature of the under surface of the olecranon and its great lateral breadth. Upon its inner or radial side, it is produced in such a way as to form a broad shelf-like projection, as in the Binturong; it is relatively short and thick as in this latter species, in marked contrast with its elongated form in many of the contemporary Creodonts. The posterior wall of the greater sigmoid cavity has comparatively little elevation, giving to the cavity a shallow appearance, but the anterior boundary or coronoid process is prominent and well extended upon its radial side. Just in front of this latter process is seen the deep muscular impression for the attachment of the tendon of the anterior brachial muscle. The shaft is considerably flattened from side to side and traversed by broad shallow longitudinal grooves, which continue to the distal end. In the lower fourth of its extent, the shaft becomes sharply triangular in cross-section by reason of the development of a sharp ridge from the more or less rounded internal surface. This

ridge is very highly developed in the Binturong and less so in *Herpestes*. The distal end is not preserved.

The radius, figure 28, as compared with the ulna in size, holds about the same relationship as that seen in the civets in general. The head is cup-shaped and has an imperfectly circular outline, indicating thereby complete power of rotation.

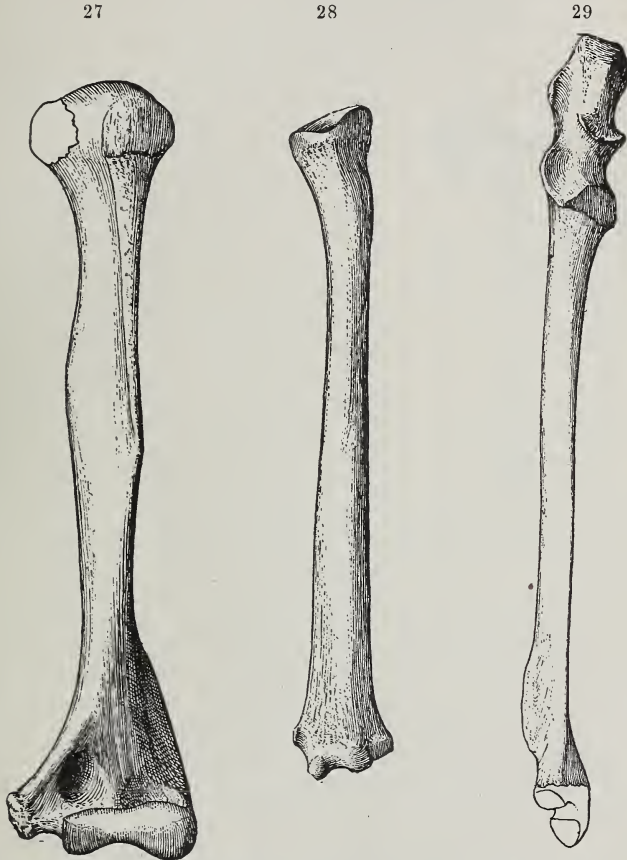

FIGURE 27.—Humerus of *Oodectes herpestoides* Wortman; front view.

FIGURE 28.—Radius of same species; front view.

FIGURE 29.—Ulna of same species; front view.

All figures are three halves natural size. (Type.)

The shaft is slightly curved, somewhat compressed, and distinctly trihedral in its lower fourth. The distal end is provided with a well-developed styloid, deep tendinal grooves, and a well-excavated articular surface for the scaphoid and lunar.

The manus, figure 30, is sufficiently preserved to furnish a fair idea of its organization. All the carpal bones are present with the exception of the lunar, magnum, and pisiform. The scaphoid, centrale, trapezium, and trapezoid, with the proximal portions of the first three metacarpals attached, were found in the position shown in the accompanying figure, and there is reason to believe that the positions of the bones are substantially correct. The scaphoid is relatively large, and is articulated distally with the trapezium,

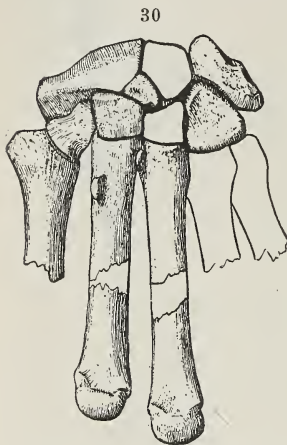

FIGURE 30.—Left manus of *Oödestes herpestoides* Wortman; two and one-fourth times natural size. (Type.)

trapezoid, and centrale. The trapezium is of moderate size and supports the pollex in the usual way, which is not to any very great degree opposable, if at all. The trapezoid is rather large, of an imperfectly triangular form, and supports the second metacarpal. The centrale may be said to have an outline intermediate between a quadrate and triangular pattern; it rests unequally upon trapezoid and magnum, and lies under the junction of the scaphoid and lunar. The unciform resembles that of the modern civets, and presents a lateral facet for articulation with the lunar. The cuneiform is flattened from above downwards, and articulated with the unciform in quite the usual way.

Of the metacarpals, that of the pollex is the heaviest, the second and third being more slender, with rather narrow proximal extremities. On the upper portion of the shaft of the second is seen a prominent tuberosity, and a less conspicuous one upon the third near the proximal extremity. These bony protuberances, if normal, probably served for the attachment of the long and short carpal extensors, since, in position, they correspond nearly to the insertion of these muscles. The length of the metapodials cannot be ascertained, but they were presumably short. Their distal ends are hemispherical and keeled like those of the modern civets. Some fragments of the proximal row of phalanges are preserved, and these are again like those of *Herpestes* and the Binturong. One perfect phalanx, figure 31, belonging probably to the second row of the fore foot, is long and slender, notably more so than in the Binturong, wherein they are longer than usual in the Viveridæ. No ungual phalanges are known.

[To be continued.]

ART. XVI.—*The Electromagnetic Effects of Moving Charged Spheres*; by EDWIN P. ADAMS.

THE magnetic effects due to moving charges were first shown experimentally by Professor Rowland* in 1876. Dr. E. Lecher,† in 1884, thinking that the importance of the experiment rendered its repetition desirable, did so, but with negative results. Insufficient data regarding his experiment make it difficult to point out the cause of his failure to obtain the effect. Since then, Professor Rowland's results have been fully confirmed by Professor W. C. Röntgen‡ in 1885; by Rowland and Hutchinson§ in 1889; and by Professor F. Himstedt|| later in the same year.

The next experimental attack upon this problem was by M. V. Cremieu¶ at Paris in 1900–1. His experiments were originally undertaken to determine whether a changing magnetic field exerts a mechanical force upon an electrically charged body. The negative results obtained led him to undertake a series of experiments on the magnetic effect of moving electric charges. The results of these experiments are apparently all opposed to the results obtained by the above observers. The data which have thus far appeared do not give sufficient details to render it certain that positive results should have been expected. Cremieu himself states that he is convinced that the effect does not exist.

The great importance of the experiment would seem to render further investigation desirable, and the present paper contains a description of an experiment with this end in view.

All previous experiments have been made with rotating disks. With one exception the direct effect of a charged rotating disk upon a magnetic needle has been examined. The exception referred to is the method employed by Cremieu in one of his experiments where he sought to observe the inductive effect of charging and discharging a rotating disk upon a neighboring coil of wire in circuit with a sensitive galvanometer.

The use of charged spheres was suggested by Professor J. J. Thomson** in 1881, and he gives a calculation of the mag-

* This Journal (3), xv, p. 30, 1878.

† Rep. d. Phys., xx, p. 151, 1884.

‡ Sitz. d. Berlin Akad., p. 198, 1885.

§ Phil. Mag. (3), xxvii, p. 445, 1889.

|| Wied. Ann., xxxviii, p. 560, 1889.

¶ Comptes Rendus, cxxx, p. 1544; cxxxi, p. 578; cxxxi, p. 797; cxxxii, p. 327.

** Phil. Mag., xi, p. 236, 1881.

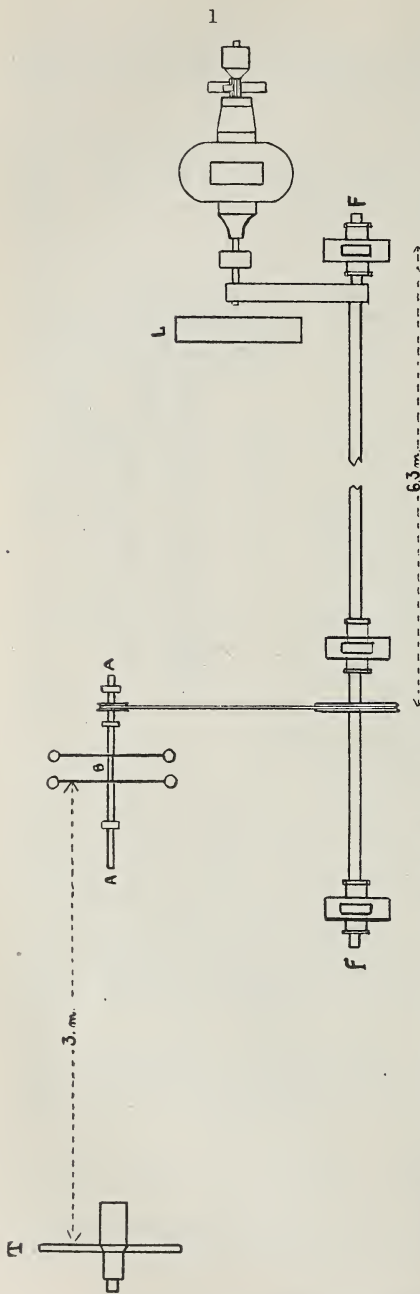

netic force which would be produced by the motion of a sphere charged to the highest possible potential. In many respects this seems the most natural method of procedure, and was adopted in this experiment. The description of the apparatus employed follows.

A hollow brass shaft, AA (figs. 1 and 2), is separated into two portions by the hard wood bar B. The shaft turns in fiber bearings, and the pulley and belt at D, fig. 2, communicate power from the countershaft FF. The spheres which carry the electric charges are spun out of sheet copper into hemispheres, soldered together. There are two sets of spheres, 16 in each set. Brass rods pass through the hollow spheres, and are soldered to them. These brass rods are screwed into collars carried on the axle. The two sets of spheres are thus insulated from each other by the hard wood bar, 8^{cm} in length. The electricity is communicated to the two portions of the axle by the copper brushes OC, fig. 2, and the spheres, being in contact with the axle, thus become charged themselves.

The speed-counter E, fig. 2, is directly attached to one end of the axle. The gearing is so proportioned that one revolution of the crown-gear and dial I, cor-

responds to 500 revolutions of the axle.

The magnetic system upon which the direct effect of the moving charged spheres is observed, is enclosed in the brass tube H, closed on the bottom by a glass plate coated with tin-foil. This tin-foil is cut into strips parallel to the axle for the purpose of preventing conduction currents flowing in it in a direction in which they could cause a deflection of the needle. The needle-system is carried on a piece of mica, 7.5^{cm} long and 1.25^{cm} wide. Pieces of well-hardened magnetized watch-

2

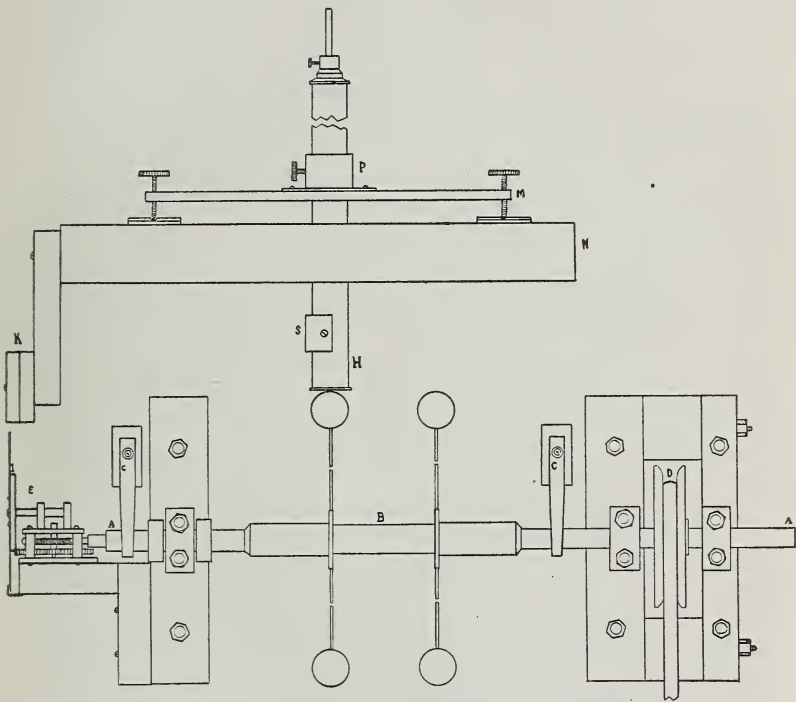

spring are cemented at the lower edge and near the upper edge of the mica so as to form an astatic system. The needles are placed perpendicularly to the axle. The mirror is also cemented to the mica, a little above its center, and is observed through an opening in the brass tube at S, covered with a thin glass plate. The whole needle-system is suspended by a quartz fiber, 32^{cm} in length.

The magnetometer tube H is carried in a brass collar P, which is screwed to the brass plate M. This plate is provided with levelling screws, and rests on the board shelf N, supported at its ends on two brick piers. Underneath the levelling screws are placed pieces of felt, to take up any mechanical

vibrations. By means of control magnets placed on the brass plate M any required degree of sensitiveness can be given to the needle-system. All metallic parts of the magnetometer tube and supports are earthed. A single turn of wire at K serves to determine the needle-constant. The deflections are read by means of the telescope and scale T, placed at a distance of 3 meters from the mirror.

Power for driving the spheres is furnished by a 4 horse-power motor, at a distance of 7 meters from the magnetometer. A heavy iron casting, L, in front of the motor, gives additional screening of magnetic disturbances due to the motor. The motor is belted to the steel countershaft, FF, which turns in hangers placed along the cement floor. A rigid wooden framework is built up from the floor to carry the revolving spheres. The axle AA is at a distance of 1 meter from the floor. The brick piers which support the magnetometer are entirely separate from the floor and from the framework which carries the spheres.

The electricity for charging the spheres is furnished by the battery of 10,000 storage cells used by Professor Trowbridge in investigations in spectrum analysis, etc., and which has been described by him in this Journal. The battery is on the third floor of the laboratory, while the apparatus for this experiment was set up in the basement. The wires leading down from the battery are well separated from each other and from surrounding walls, except for a short distance, where they are carried in thick-walled glass tubes. A commutator is inserted to reverse the sign of the charges of the spheres.

A good deal of difficulty was met with due to the wind produced by the revolving spheres. These have a velocity of about three miles a minute, and the wind was sufficient to shake the shelf supporting the magnetometer so that it was impossible to take readings owing to the continual vibration of the needle-system. This made it necessary to build a shield around the spheres to keep the wind from blowing directly on any part of the magnetometer support. In order to bring the needles as close as possible to the spheres, the top board of the shield has a hole cut in it into which the lower end of the magnetometer tube is placed. The hole is closed on the bottom by a very thin glass plate, which the spheres just clear when revolving.

Not the slightest movement of the needle could be observed when the motor alone was run, or when the motor and steel-shaft along the floor were run. But the cutting of the earth's magnetism by the brass axle was sufficient to produce a deflection of several centimeters. As long as the speed remained perfectly constant this gave no trouble. But if the speed

varied by even a small amount this was very troublesome, and was one of the principal sources of error in the experiment.

The two sets of spheres are charged oppositely, one being connected to the positive pole of the battery and the other to the negative pole. On charging them while at rest a very small deflection was observed. This was not due to direct electrostatic effect, but to the rush of current flowing in to charge the spheres. It is only an instantaneous effect, the needle coming back to its original position of equilibrium almost immediately. This deflection was entirely gotten rid of by inserting a large water-resistance in series with the battery. With this resistance in, and the spheres at rest, no effect could be observed on the needle when the spheres were charged, or when the charge was reversed in sign.

When the spheres were set revolving, and the electrification was reversed, a distinct deflection of the needle was produced. It was difficult always to get satisfactory readings of this deflection due to slight changes in the speed and the consequent change of the zero-point. But the qualitative effect was unmistakable. The deflection was in the direction to be expected; that is, a positively charged sphere gives rise to a magnetic force in the same sense as a current flowing in the direction of motion.

At first sight there seems to be a possible alternative explanation of this effect. It may be that the charges are continually swept off from the rapidly moving spheres by their motion through the air, and that thus a continual flow of electricity is produced in the wires which connect the battery to the spheres. But the strength of such a current, if it existed, would be far too small to produce the observed effects owing to the very large resistance of the water in series with the battery. With this consideration, and the absolute regularity with which the effect was observed, there appears to be no reasonable doubt that this is an actual magnetic effect due to moving charges.

All observations were made between the hours of one and five in the morning. It was impossible to get any satisfactory readings in the day time, owing mainly to the magnetic disturbances produced by the electric cars. Furthermore, the speed of the motor was more constant at that time than during the day, since the load on the mains of the power-plant varied less. It was found most satisfactory to have the sensitiveness of the needle such that a deflection of 5-15 millimeters was produced on reversing the electrification. Much greater sensitiveness could easily have been obtained, but the zero-point varied so much that the readings were less reliable. The speed used was about 50 revolutions per second. At this speed no trouble was experienced from wind or from vibrations commu-

nicated directly to the magnetic system. But when the speed exceeded 60 revolutions per second the needle began to vibrate sufficiently to make observations difficult.

The following is the method used in taking a series of readings. The motor was started, and the time of 2500 revolutions of the axle determined. The spheres were then charged; two elongations of the needle on one side of the zero-position were read, and one on the other side; the electrification was then reversed, and similar readings taken. Sometimes the readings were not taken until the needle had come nearly to rest, and its new equilibrium position estimated. This was repeated until about ten reversals had been made. The speed was then again determined. The average of the deflections, and the average of the two values of the speed were taken as representing the series. The needle constant was determined before and after a number of series.

An attempt will be made in the following to compare the results obtained with the results expected from theory. From reasons which will appear later this comparison can be regarded only as approximate, and is given merely to show that the observed results are of the right order of magnitude. Rowland's method of using the experiment to determine V , the ratio of the units, will be used.

The magnetic force produced by a moving charge, q , traveling at velocity v , is:*

$$H = \frac{qv \sin \epsilon}{\rho^2}$$

where ρ is the radius vector drawn from the charge to the point at which H is measured, and ϵ is the angle between ρ and the direction of motion. This expression holds only in case the velocity v is small compared with the velocity of light. This may also be taken as the magnetic force produced by a moving charged sphere, the charge being supposed concentrated at its center. The force acts in a direction perpendicular to ρ and to the direction of motion.

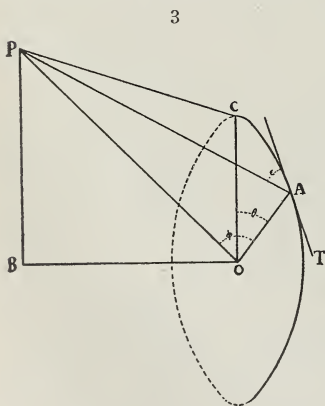

The magnetic force at either the upper or lower needle, due to one of the spheres at any point in its path, is found as follows:

The two sets of spheres revolve

* J. J. Thomson, *Phil. Mag.*, xi, p. 236, 1881; Heaviside, *Electrical Papers*, vol. ii, p. 505.

in two parallel circles, distant b from each other. The plane of revolution is taken perpendicular to the plane of the paper (fig. 3). The needles lie in one of the planes of revolution. The force at P due to the sphere at A is required.

- $\rho = PA.$
- $b = OB.$
- $d = PB.$
- $c = OC = OA = \text{radius of revolution.}$
- $\epsilon = \text{angle between } \rho \text{ and tangent at A.}$
- $\theta = \text{angle between vertical radius and radius to A.}$

$$\rho^2 = d^2 + b^2 + c^2 - 2c\sqrt{d^2 + b^2} \cos \phi$$

$$\cos \phi = \cos \theta \frac{d}{\sqrt{d^2 + b^2}}$$

$$\rho^2 = d^2 + b^2 + c^2 - 2dc \cos \theta$$

$$\cos \epsilon = \frac{d \sin \theta}{\rho}$$

$$\sin \epsilon = \sqrt{\frac{(d \cos \theta - c)^2 + b^2}{d^2 + b^2 + c^2 - 2dc \cos \theta}}$$

The force acts in a direction perpendicular to ρ and the tangent at A. The component of this force in the direction of the normal to the plane of revolution is required. Let ψ be the angle between the direction of the force and the normal to the plane of revolution.

$$\cos \Psi = \frac{d \cos \theta - c}{\sqrt{(d \cos \theta - c)^2 + b^2}}$$

$$v = 2\pi cN$$

where N is the number of revolutions per second.

Hence :

$$X = \frac{2\pi Nc\gamma (d \cos \theta - c)}{V[d^2 + b^2 + c^2 - 2dc \cos \theta]^{\frac{3}{2}}}$$

X is the component of the force at P in the direction of the axle due to the sphere at A. V is the ratio of the units. The capacity of the spheres and their potential are measured in electrostatic units.

Figure 4 is plotted from this expression, and shows how the force varies with the position of the spheres. The upper curve gives the resultant force at the lower needle due to both sets of spheres, and the lower curve, which is nearly a straight line, gives the force at the upper needle. Let the mean value of

the force at the lower needle obtained by time-integration of the curve be :

$$\frac{2\pi Nq}{V} A$$

and the mean value of the force at the upper needle :

$$\frac{2\pi Nq}{V} B$$

4

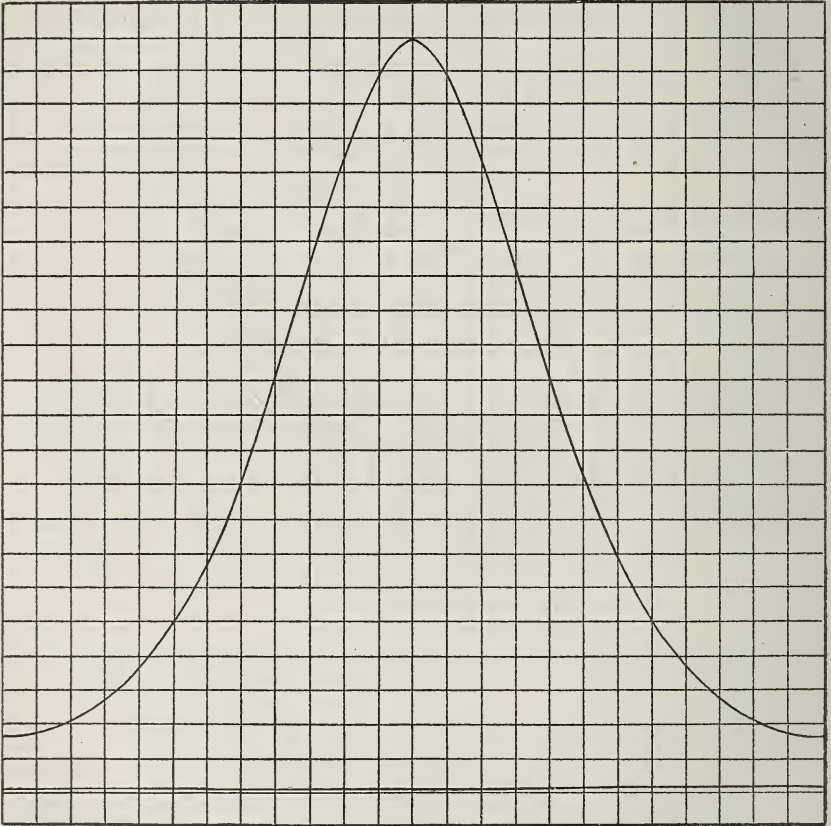

Then the effect on the needle will be the same as if constant forces of these magnitudes acted upon it. The same result could be obtained by imagining two coils of wire passing through the centers of the two sets of spheres through which a current was sent in opposite directions of such a magnitude that the same amount of electricity passed any point per second as in the case of the charged spheres.

Force at lower needle due to calibrating coil :

$$\frac{2\pi Ih^2}{(h^2 + x^2)^{\frac{3}{2}}} = 2\pi IC$$

h being the radius of the coil, and x its distance from the plane of the needles.

Force at upper needle due to calibrating coil :

$$2\pi I \left[\frac{1}{r} \left(\frac{h}{r} \right)^2 P_2(\cos \theta) - \frac{1}{r} \frac{3}{2} \left(\frac{h}{r} \right)^4 P_4(\cos \theta) + \dots \right] = 2\pi ID$$

r being the distance of the center of the coil to the upper needle, and θ the angle between the axis of the coil and r .

Let M be the moment of the lower needle, and H the earth's horizontal magnetic force at its center; M' and H' the corresponding values for the upper needle. Let θ be the angular deflection of the needle-system produced by the current in the calibrating coil, and ϕ the angular deflection produced by the moving charged spheres.

Equating the couple acting on the needle-system due to the earth's field to the couple acting on the needle-system due to the current in the calibrating coil, and putting $M/M' = 1$, we have :

$$\frac{HM - H'M'}{M} = \frac{2\pi I(C - D)}{\tan \theta}$$

Similarly, equating the couple acting on the needle-system due to the earth's field to the couple acting on the needle-system due to the revolving charged spheres, we have :

$$\frac{HM - H'M'}{M} = \frac{2\pi Nq(A - B)}{V \tan \phi}$$

Hence

$$V = \frac{A - B}{C - D} \frac{Nq \tan \theta}{I \tan \phi}$$

Let δ be the scale deflection on reversing the current I in the calibrating coil, and Δ the scale deflection on reversing the charges of the spheres. Then :

$$V = \frac{A - B}{C - D} \frac{Nq \delta}{I \Delta}$$

d and d' , the distances of the centers of the lower and upper needles respectively from the axle, were determined by means of a cathetometer, the distance of the mirror from the center of the axle being directly measured, from which d and d' were obtained.

The current sent through the calibrating coil for determining the needle-constant was measured by a Weston milliammeter.

The value found was accurate to at least one-half of one per cent. which is sufficient for this purpose.

The charge of the spheres is the most uncertain element in the quantitative determination, and it is this uncertainty especially which makes the method of revolving spheres far less suitable for quantitative work than the method of rotating disks, particularly as employed by Rowland in his second experiment. If a single set of spheres had been used, charged to the same potential, an equal opposite charge would have been induced on neighboring conductors which would have travelled with the charges on the spheres. It would have been difficult to determine just what the resultant effect should be. For this reason two distinct sets of spheres were used, charged oppositely, the spheres always keeping the same relative positions. It was then assumed that the only moving charges were those carried on the moving spheres. The capacity of the spheres was calculated on the assumption that they were the only conductors present. The charge on any one sphere was calculated by the method of images, the charges on all the other spheres being regarded as concentrated at their centers. We then have (Maxwell, volume i, section 159):

$\pm q$ = charge of each sphere.

$\pm P$ = its potential.

a = its radius.

f_1, f_2 , etc. = the distances of the centers of the spheres from one another.

Then the charge on any sphere is given by:

$$q = Pa - qa \left(\frac{1}{f_1} + \frac{1}{f_3} + \dots \right) + qa \left(\frac{1}{f_2} + \frac{1}{f_4} + \dots \right)$$

where the odd subscripts refer to spheres of the same set and even subscripts to spheres of the other set.

Numerous determinations have shown that the potential of the individual cells making up the battery averages almost exactly two volts when freshly charged. On this basis, assuming perfect insulation, the potential used was 20,000 volts. It was thought best, however, to get a closer estimate of the potential, since the insulation was not perfect. This was measured by means of a guard-ring electrometer. If the radius of the movable disk is R , the inside radius of the guard-ring R' , D the distance between the moveable disk and the fixed disk, W the weight required to balance the attraction of the two disks, and g the acceleration of gravity,*

* Maxwell, volume i, section 217.

$$P = 4D\sqrt{\frac{gW}{R^2 + R'^2}}$$

$$R = 5.933$$

$$R' = 6.033$$

$$g = 980.$$

The following determinations were made:

D	G	P
3.0	2.078	64.0
2.5	2.780	62.0
2.0	4.505	63.0

These values of the potential are in electrostatic units. To convert into volts multiply by 300, and the potential as measured by the electrometer is 18,900.

As a further check the maximum sparking distance between two metallic spheres was measured. With polished brass spheres, 2.6^{cm} in diameter, this distance was found to be 0.58^{cm}. According to the observations of Baille,* this corresponds to a potential:

$$P = 63$$

Baille's observations were with spheres of different sizes. In the region of a spark-length of this magnitude, he found that spheres of 3^{cm} diameter gave nearly the same results as spheres 1^{cm} in diameter, so that his results for spheres of 3^{cm} diameter can be used with very small error for spheres 2.6^{cm} in diameter.

From these determinations, the value

$$P = 63$$

in electrostatic units is taken as the potential of the spheres. The great advantage in using a storage battery as the source of electricity is that one measurement is sufficient to determine the potential. The battery when used was always freshly charged, and the variations in its potential from one experiment to another were very small.

Substituting the following numerical values:

Radius of spheres =	1.35
<i>c</i>	= 20.38
<i>d</i>	= 22.91
<i>d'</i>	= 29.28
<i>b</i>	= 8.16
<i>x</i>	= 19.30
<i>h</i>	= 2.55

we find

A-B	= 1.541
C-D	= 0.000232
<i>q</i>	= 1.38 × 63

* J. J. Thomson, Recent Researches, p. 77.

Below are given the successive equilibrium positions of the needle in six series of reversals, as an illustration of the results that have been obtained :

No. 1.		No. 2.		No. 3.	
	63		165		130
60	66	172	178	109	122
64	76	188	223	122	130
71	79	200	220	112	130
69	76	213		121	140
69				146	156
				164	171
				162	

The needles were then moved a little closer to the spheres, giving :

$$d = 22.47$$

$$d' = 28.84$$

$$A-B = 1.834$$

No. 4.		No. 5.		No. 6.	
92	114		164	108	84
106	135	148	156	113	118
120	135	148	149	108	155
142	149	152	143	125	135
164	192	139	155		
		147			

In all these cases, the first column gives the readings when the spheres directly under the magnetometer are positively charged, and the second column when they are negatively charged. In No. 1, the successive deflections are: 3, 6, 2, 12, 5, 8, 10, 7, 7; giving an average of 6.7. In No. 4 they are: 21, 13, 0, 8, 18, 18, 9, 19, -6, 10, -8, 7, 9; giving an average of 9. It is evident that with variations such as are present here the measurements can be regarded only as a rough approximation. But the most important fact to be observed is that when the spheres directly under the magnetometer are changed from negative to positive a deflection toward the small figures of the scale takes place; and when changed from positive to negative a reverse deflection takes place. When on account of changes in the zero-point some of the deflections do not apparently follow this rule, they are entered with a negative sign in finding the average deflection. There has invariably resulted a positive deflection on taking the average.

Earlier experiments were made with four spheres in each set. With this number it was possible to get much higher speeds—75–85 revolutions per second. Similar qualitative results were observed, but when comparison with theory was attempted it appeared that fair agreement could be obtained if

the maximum value of the magnetic force were used instead of the average. This was largely an accidental result, a sufficient number of reversals not having been made.

It would have been desirable to have made a larger number of reversals in each series, but after the apparatus had been running for some time the bearings heated so much that it was impracticable.

The following table gives the values of the ratio of the units obtained from the above readings :

No	N	Λ	I	δ	V	
1	42	6.7	.00364	26	2.6	10^{10}
2	55	10.6	.00355	31	2.6	
3	55	9.0	.00355	31	3.1	
4	49	11.3	.00298	29	2.9	
5	41	5.5	.00280	15	2.7	
6	48	7.0	.00280	15	2.6	
Average					2.8	10^{10}

These results may be taken as fairly representing all that have been obtained. The agreement between theory and experiment is fully as good as could be expected when all the uncertain elements in the determination are taken into consideration.

These uncertain elements are: (1) The actual charges carried by the spheres and the effect of surrounding bodies, especially the plate coated with tin-foil covering the lower end of the magnetometer tube. This tin-foil is cut into strips about 1 millimeter in width and its effect must be small. (2) The non-uniformity of distribution of electricity upon the spheres so that the charges cannot be regarded accurately as concentrated at their centers. (3) Errors in reading the deflection of the needle due to outside disturbances.

Experiments have also been made with the direction of motion of the spheres reversed. The results obtained are similar in every respect to those given above, except that they are reversed. Experiments using only a portion of the 10,000 cells of the storage battery gave results which agree fairly well with the preceding. The deflections were too small, however, to expect very close agreement.

Jefferson Physical Laboratory, Harvard University, Cambridge, Mass.

ART. XVII.—*The Nadir of Temperature and Allied Problems*; by JAMES DEWAR, LL.D., F.R.S. [Bakerian Lecture (abstract) read before the Royal Society,* June 13, 1901.]

1. Physical Properties of Liquid and Solid Hydrogen. 2. Separation of Free Hydrogen and other Gases from Air. 3. Electric Resistance Thermometry at the Boiling Point of Hydrogen. 4. Experiments on the Liquefaction of Helium at the Melting Point of Hydrogen. 5. Pyroelectricity, Phosphorescence, etc.

Details are given in this paper which have led to the following results:—

The helium thermometer which records $20^{\circ}\cdot 5$ absolute as the boiling point of hydrogen, gives as the melting point 16° absolute. This value does not differ greatly from the value previously deduced from the use of hydrogen gas thermometers, viz., $16^{\circ}\cdot 7$. The lowest temperature recorded by gas thermometer is $14^{\circ}\cdot 5$, but with more complete isolation and a lower pressure of exhaustion, it will be possible to reach about 13° absolute, which is the lowest temperature that can be commanded by the use of solid hydrogen. Until the experiments are repeated with a helium gas thermometer filled at different pressures, with the gas previously purified by cooling to the lowest temperature that can be reached by the use of solid hydrogen, no more accurate values can be deduced.

The latent heat of liquid hydrogen about the boiling point as deduced from the vapor pressures and helium-thermometer temperatures, is about 200 units, and the latent heat of solid hydrogen is about 16 units.

The order of the specific heat of liquid hydrogen has been determined by observing the percentage of liquid that has to be quickly evaporated under exhaustion in order to reduce the temperature to the melting point of hydrogen, the vacuum vessel in which the experiment is made being immersed in liquid air. It was found that in the case of hydrogen the amount that had to be evaporated was 15 per cent. This value, along with the latent heat of evaporation, gives an average specific heat of the liquid between freezing and boiling point of about 6. When liquid nitrogen was similarly treated for comparison, the resulting specific heat of the liquid came out 0·43 or about 6 per atom. Hydrogen therefore follows the law of Dulong and Petit, and has the greatest specific heat of any known substance.

The same fine tube used in water, liquid air, and liquid hydrogen gave respectively the capillary ascents of 15·5, 2 and 5·5 divisions. The relative surface tension of water, liquid air, and liquid hydrogen are therefore in the proportion of 15·5, 2, 0·4. In other words, the surface tension of hydrogen at its

* From an advance proof received from the author.

boiling point is about one-fifth that of liquid air under similar conditions. It does not exceed one thirty-fifth part the surface tension of water at the ordinary temperature.

The refractive index of liquid hydrogen, determined by measuring the relative difference of focus for a parallel beam of light sent through a spherical vacuum vessel filled in succession with water, liquid oxygen, and liquid hydrogen, gave the value 1.12. The theoretical value of the liquid refractive index is 1.11 at the boiling point of the liquid. This result is sufficient to show that hydrogen, like liquid oxygen and nitrogen, has a refractivity in accordance with theory.

Free hydrogen, helium, and neon have been separated from air by two methods. The one depends on the use of liquid hydrogen to boil the dissolved gases out of air kept at a temperature near the melting point of nitrogen; the other on a simple arrangement for keeping the more volatile gases from getting into solution after separation by partial exhaustion. By the latter mode of working something like $1/34000$ th of the volume of the air liquefied appears as uncondensed gas. The latter method is only a qualitative one for the recognition and separation of a part of the hydrogen in air. In a former paper on the "Liquefaction of Air and the Detection of Impurities,"* it was shown that 100 cc. of liquid air could dissolve 20 cc. of hydrogen at the same temperature. The crude gas separated from air by the second method gave on analysis—hydrogen 32.5 per cent., nitrogen 8 per cent., helium, neon, &c., 60 per cent. After removing the hydrogen and nitrogen the neon can be solidified by cooling in liquid hydrogen and the more volatile portions separated.

There exists in air a gaseous material that may be separated without the liquefaction of the air. For this purpose air has to be sucked through a spiral tube filled with glass wool immersed in liquid air. After a considerable quantity of air has been passed, the spiral is exhausted at the low temperature of the liquid air bath. The spiral tube is now removed and allowed to heat up to the ordinary temperature, and the condensed gas taken out by the pump. After purification by spectroscopic fractionation the gas filled into vacuum tubes gives the chief lines of xenon. The spectroscopic examination of the material will be dealt with in a separate paper by Professor Liveing and myself. A similar experiment made with liquid air kept under exhaustion, the air current allowed to circulate being under a pressure less than the saturation pressure of the liquid to prevent liquefaction, resulted in krypton being deposited along with the xenon.

A study of fifteen electric-resistance thermometers as far as the boiling point of hydrogen, has been made, and the results

* Chem. Soc. Proc., 1897.

reduced by the Callendar and Dickson methods. The table [here omitted] gives the results for seven thermometers, viz., two of platinum, one of gold, silver, copper, and iron, and one of platinum-rhodium alloy. Of these the lowest boiling point for hydrogen was given by the gold thermometer. Next to it came one of the platinum thermometers, and then silver, while copper and the iron differ from the gold value by 26 and 32 degrees respectively. The gold thermometer would make the boiling point $23^{\circ}\cdot 5$ instead of the $20^{\circ}\cdot 5$ given by the gas thermometer. Then the reduction of temperature under exhaustion amounts to only 1° instead of 4° as given by the gas thermometer. The extraordinary reduction in resistance of some of the metals at the boiling point of hydrogen is very remarkable. Thus copper has only $1/105$ th, gold $1/30$ th, platinum $1/35$ th to $1/17$ th, silver $1/24$ th the resistance at melting ice, whereas iron is only reduced to $1/8$ th part of the same initial resistance. The real law correlating electric resistance and temperature within the limits we are considering is unknown, and no thermometer of this kind can be relied on for giving accurate temperatures up to and below the boiling point of hydrogen. The curves are discussed in the paper, and I am indebted to Mr. J. H. D. Dickinson and Mr. J. E. Petavel for help in this part of the work.

Helium separated from the gas of the King's Well, Bath, and purified by passing through a U-tube immersed in liquid hydrogen, was filled directly into the ordinary form of Cailletet gas receiver used with his apparatus, and subjected to a pressure of 80 atmospheres, while a portion of the narrow part of the glass tube was immersed in liquid hydrogen. On sudden expansion from this pressure to atmospheric pressure a mist from the production of some solid body was clearly visible. After several compressions and expansions, the end of the tube contained a small amount of a solid body that passed directly into gas when the liquid hydrogen was removed and the tube kept in the vapor of hydrogen above the liquid. On lowering the temperature of the liquid hydrogen by exhaustion to its melting point, which is about 16° absolute, and repeating the expansions on the gas from which the solid had separated by the previous expansions at the boiling point or $20^{\circ}\cdot 5$, *no mist was seen*. From this it appears the mist was caused by some other material than helium, in all probability neon, and when the latter is removed no mist is seen, when the gas is expanded from 80 to 100 atmospheres, even although the tube is surrounded with solid hydrogen. From experiments made on hydrogen that had been similarly purified like the helium and used in the same apparatus, it appears a mist can be seen in hydrogen (under the same conditions of expansion as applied to the helium sample of gas) when the initial

temperature of the expanding gas was twice the critical temperature, but it was not visible when the initial temperature was about two and a-half times the critical temperature. This experience applied to interpret the helium experiments, would make the critical temperature of the gas under 9° absolute.

Olszewski in his experiments expanded helium from about seven times the critical temperature under a pressure of 125 atmospheres. If the temperature is calculated from the adiabatic expansion starting at 21° absolute, an effective expansion of only 20 to 1 would reach $6^{\circ}\cdot 3$, and 10 to 1 of $8^{\circ}\cdot 3$. It is now safe to say, helium has been really cooled to 9° or 10° absolute without any appearance of liquefaction. There is one point, however, that must be considered, and that is the small refractivity of helium as compared to hydrogen, which, as Lord Rayleigh has shown, is not more than one-fourth the latter gas. Now as the liquid refractivities are substantially in the same ratio as the gaseous refractivities in the case of hydrogen and oxygen, and the refractive index of liquid hydrogen is about 1.12, then the value for liquid helium should be about 1.03, both taken at their respective boiling points. In other words, liquid helium at its boiling point would have a refractive index of about the same value as liquid hydrogen at its critical point, and as a consequence, small drops of liquid helium forming in the gas near its critical point would be far more difficult to see than in the case of hydrogen similarly situated.

The hope of being able to liquefy helium, which would appear to have a boiling point of about 5° absolute, or one-fourth that of liquid hydrogen, is dependent on subjecting helium to the same process that succeeds with hydrogen; only instead of using liquid air under exhaustion as the primary cooling agent, liquid hydrogen under exhaustion must be employed, and the resulting liquid collected in vacuum vessels surrounded with liquid hydrogen. The following table embodies the results of experience and theory:—

Initial temperature.	Initial temperature.	Critical temperature.	Boiling points.
Liquid helium?.....	$5^{\circ}?$	$2^{\circ}?$	$1^{\circ}?$
Solid hydrogen.....	15	6	4
Liquid ".....	20	8	5 (He?)
Exhausted liquid air.....	75	30	20 (H)
52° C.....	325	130	86 (Air)
Low Red Heat.....	750	304	195 (CO ₂)

The first column gives the initial temperature before continuous expansion through a generator, the second the critical point of the gas that can be liquefied under such conditions, and the third the boiling point of the resulting liquid. It will

be seen that by the use of liquid or solid hydrogen as a cooling agent we ought to be able to liquefy a body having a critical point of about 6° to 8° absolute and boiling point of about 4° or 5° absolute. Then, if liquid helium could be produced with the probable boiling point of 5° absolute, this substance would not enable us to reach the zero of temperature; another gas must be found that is as much more volatile than helium as it is than hydrogen in order to reach within 1° of the zero of temperature. If the helium group comprises a substance having the atomic weight 2, or half that of helium, such a gas would bring us nearer the desired goal. In the meantime the production of liquid helium is a difficult and expensive enough problem to long occupy the scientific world.

A number of miscellaneous observations have been made in the course of this inquiry, among which the following may be mentioned. Thus the great increase of phosphorescence in the case of organic bodies cooled to the boiling point of hydrogen under light stimulation is very marked, when compared with the same effects brought about by the use of liquid air. A body like sulphide of zinc cooled to 21° absolute and exposed to light shows brilliant phosphorescence on the temperature being allowed to rise. Bodies like radium that exhibit self-luminosity in the dark, cooled in liquid hydrogen maintain their luminosity unimpaired. Photographic action is still active although it is reduced to about half the intensity it bears at the temperature of liquid air. Some crystals when placed in liquid hydrogen become for a time self-luminous, on account of the high electric stimulation brought about by the cooling causing actual electric discharges between the crystal molecules. This is very marked with some platino-cyanides and nitrate of uranium. Even cooling such crystals to the temperature of liquid air is sufficient to develop marked electrical and luminous effects. Considering that both liquid hydrogen and air are highly insulating liquids, the fact of electric discharges taking place under such conditions proves that the electrical potential generated by the cooling must be very high. When the cooled crystal is taken out of either liquid and allowed to increase in temperature, the luminosity and electric discharges take place again during the return to the normal temperature. A crystal of nitrate of uranium gets so highly charged electrically that, although its density is 2.8 and that of liquid air about 1, it refuses to sink, sticking to the side of the vacuum vessel and requiring a marked pull on a silk thread, to which it is attached, to displace it. Such a crystal rapidly removes cloudiness from liquid air by attracting suspended particles to its surface. The study of pyro-electricity at low temperatures will solve some very important problems.

SCIENTIFIC INTELLIGENCE.

1. *Magnetic effect of Electrical Convection.*—The magnetic effect produced by the motion of an electrified body, first proved by Rowland in 1876, and, though questioned by Cremieu, since then repeatedly confirmed (see the article by Edwin P. Adams in the present number, pp. 155–167, of this Journal), has been also established by HAROLD PENDER at the Johns Hopkins Physical Laboratory. An account of his experiments is given in a recent issue of the Johns Hopkins University Circular (No. 152, May–June, 1901). The method of Cremieu, which, however, gave him negative results, was employed. To produce the convection, two micanite discs (diam. 30 cm.) gilded on both sides and charged from a Voss machine and battery of six gallon Leyden jars, were driven at a speed of 75 to 100 revolutions per second. An interrupter made it possible to reverse the charge 12 to 25 times per second. Earth-connected condensing plates were fixed opposite each face of each disc and one centimeter distant. Between the two inside condensing plates was suspended a coil of 1295 turns of No. 21 copper wire connected through a commutating device with an extremely delicate astatic galvanometer. The coil, circuit, and galvanometer were enclosed in earth-connected metallic shields. The arrangement of the commutator was such that the alternating current induced in the coil by the reversal of charge in the rotating discs gave a steady deflection of the galvanometer.

The apparatus was used in two ways: (*a*) the two discs were rotated in the same direction and at any instant charged alike; and (*b*) the discs were rotated in opposite directions and charged oppositely at any instant; of these, the second method gave steadier deflections and was used more frequently. The direction of deflection, repeatedly tested, was found, as expected, to be always in accordance with Ampère's rule, i. e., the motion of a positive charge always produced the same effect as that of a conduction current flowing in the direction of motion of the charge.

The quantitative results are discussed, as follows: "The strength of a convection-current is defined as the quantity of electricity carried convectively past any point in unit time. On the assumption that a convection-current is magnetically equivalent to a conduction-current of the same strength, the current induced in the suspended coil on reversing the sign of electrification of the discs can be readily calculated from the dimensions of the apparatus and the difference of potential between the discs and plates. This calculated value of the current can then be compared with the observed value as deduced from the deflection of the galvanometer. The formula for the calculated value of the current involves the ratio of the two systems of electric units, so that instead of comparing directly the observed and calculated values of the current the two can be equated and the value of the ratio v thus determined. The value of this ratio thus found is a test for the accuracy of the assumption that a convection-current is equivalent magnetically to a

conduction-current. From 17 sets of observations, each set consisting of 18 separate determinations of the deflection and the other quantities involved, the mean value of v thus found was 3.05×10^{10} , the determinations which differed from this the most being 2.75×10^{10} and 3.24×10^{10} , respectively. The value of this constant is known to be 3.00×10^{10} ." Similar results were obtained when discs and condensing plates were divided each into six sectors by radial scratches, thus showing that the effect observed was not due to conduction-currents in their surfaces.

To prove, further, that the deflection observed was actually due to the magnetic action of the rotating charged discs, a further experiment was tried. The discs were rotated in the same direction and at any instant charged oppositely; and, again, rotated in opposite directions and at any instant charged alike. Their magnetic effects on the coil should then annul one another provided the two discs rotated with the same speed, and this was the result obtained. For example, when the two discs were rotating in same direction with speeds of -86.9 and -88.8 revolutions per second, respectively, and charged alike, the observed deflection was -66.2 ; when they were rotating oppositely under the same conditions, with speeds $+88.0$ and -89.6 , the observed deflection was -1.0 .

It is concluded, therefore, that the results obtained "show beyond any doubt that *electrical convection does produce magnetic action*, or, more exactly, that when the sign of electrification of a moving charged body is changed, an electric conduction-current is induced in a neighboring circuit, of a strength equal to that which would be induced in this circuit by reversing the direction of a conduction-current in a circuit coinciding with the path of the convection-current."

2. *American Association for the Advancement of Science.*—The fiftieth annual meeting of the American Association will be held in Denver, August 24 to 31. Professor C. G. Minot of Cambridge will preside as President. The address of the Permanent Secretary, Mr. L. O. Howard, is Washington, D. C. (Cosmos Club) until Aug. 15, after that, Brown Palace Hotel, Denver. Information in regard to transportation, hotel accommodation, etc., may be obtained from the Local Secretary, Mr. Arthur Williams, Chamber of Commerce, Denver.

OBITUARY.

DR. JOSEPH LECONTE, Professor of Geology and Natural History at the University of California, died on July 6, at the age of seventy-eight years. A notice is deferred until another number.

PROFESSOR PETER GUTHRIE TAIT, the distinguished Scotch mathematician and physicist, died on July 4, at the age of seventy years. He had held the chair of Natural Philosophy in the University of Edinburgh since 1860. His original contributions, chiefly in mathematical physics, were numerous and important; he was also a lucid and suggestive writer in his treatment of scientific subjects from the popular standpoint.

AMERICAN JOURNAL OF SCIENCE

[FOURTH SERIES.]

ART. XVIII.—*The Discharge-current from a Surface of large Curvature*; by JOHN E. ALMY, Ph.D., Instructor in Physics, University of Nebraska, Lincoln.

1. THE discharge of electricity from a surface of large curvature has been studied by Warburg,* and others.† Inasmuch as the nature and form of the discharging surface, when a point, or pointed wire, is used, is necessarily more or less problematic, it seemed of interest to study the discharge from a fine wire of uniform dimension.

The discharge from a platinum wire of very small size to a concentric, circular cylinder has been the subject of study.

2. The discharge apparatus is shown in fig. 1. The brass cylinder, C, cemented to the glass plate, is further insulated by the supports of sealing-wax, *s, s*. The discharge wire, passing through the capillary tube, T, embedded in paraffin, hangs vertically, stretched by the weight of a short piece of tube, T', in which its lower end is embedded. Paraffin discs, D, D', serve to keep the wire at the center of the cylinder. The gas is removed and supplied by tubes P and

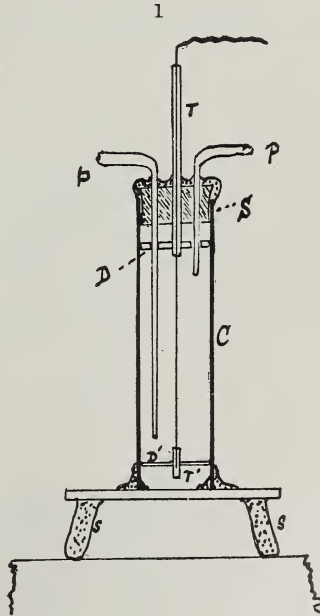

* Warburg, Wied. Ann., lxxvii, p. 82; Ann. d. Phys. (4), ii, p. 295.

† Sieveking, Ann. d. Physik. (4), i, p. 299, etc.

p. The cork, S, which closed the upper end of the cylinder, was coated with sealing-wax, surface-leakage, even when the glass tube became coated with moisture, being thus prevented.

The electric connections are sketched in fig. 2. W, a Wimshurst machine, was driven by a small motor. A galvanometer (D'Arsonval), G, measured the discharge current; potential differences between wire and cylinder were read on a 'Braun,'—later a Kelvin, 'vertical,' voltmeter, V. Potential differences were regulated by a fine discharge-point shunting the poles of the Wimshurst.

As air, which was the gas used throughout the first portion of the observations, shows some deterioration with use, when the discharge current attains to a measurable value (by "deterioration" is meant a decrease of its capacity to carry on the discharge), fresh, dried, gas was continuously drawn through the discharge apparatus.

As only relativity was wished for, the voltmeter and galvanometer were not standardized; nor were the variations of atmospheric pressure, from day to day, noted.

Observations.

3. First, the proportionality of total discharge to length of the discharge wire was tested. It was found, that so long as

2

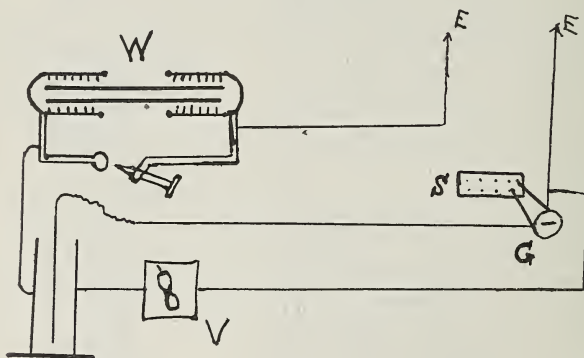

the length of wire is greater than the diameter of the cylinder, and with the paraffin discs restricting the volume of the gas which takes part in the discharge to the solid cylinder of the length of the wire, the current is directly proportional to the length of the wire, with a given applied potential, and the minimum potential difference that will produce measurable discharge current is independent of the length of the wire.

In case short lengths (as compared to cylinder diameter)

were used, or the discs were dispensed with, exact proportionality no longer holds.

A series of observations illustrating this proportionality are given:

TABLE I.

Potentials.	Values of the quotient.		Current.	Wire length.
	L = 31 ^{cm} .	L = 25 ^{cm} .		
14	16·7	15·7	17·3	16·0
16	36·1	35·4	36·6	34·
18	60·6	59·3	60·6	60·
20	90·0	90·2	92·6	88·
22	120·	118·2	122·	120·
24	----	160·	162·	163·
26	----	----	214·	216·

Diameter of cylinder, 9·4^{cm}.

Diameter of wire, 0·0047^{cm}.

4. The relation holding between the applied potential and the resulting discharge current is found to be expressed by the quadratic:

$$I = aLV(V-b)$$

I, V, and L, having the usual significance, and a and b are constants, depending upon the cylinder, wire, and gas. The constant b is found to approximate, more or less closely, to the "minimum-potential" of Röntgen, i. e., the least potential which will give the measureable discharge.

This law was found applicable for cylinders of diameters, from 2 to 10^{cm}, giving agreement within errors of observation, except for potentials which differed only very slightly from the "minimum potential." Even after the gas had been used for a considerable time without renewal and also at widely varying pressures (from 20 to 80^{cm} of mercury) the relation between current and potential remains similar, with, naturally, different constants. As illustration I cite a series, taken at random from the considerable number of observations made:

TABLE II.

V (arbitrary units.)	I		V (of cylinder.)	I	
	(calc.)	(observ.)		(calc.)	(obs.)
13	13·7	17·0	—14	15·3	17·
14	26·5	27·	—16	36·2	36·
16	56·	55·	—18	62·	61·
18	92·	92·	—20	92·	92·
20	135·	138·	—22	126·	122·
22	184·	186·	—24	166·	162·
24	240·	240·	—26	210·	206·
26	313·	320·	—28	260·	257·
			—30	313·	315·

$a = \cdot 543$; $b = 11\cdot 7$.

$a = \cdot 389$; $b = 12\cdot 15$.

Length of wire, 15^{cm}; diameter, 0·0047^{cm}; diameter of cylinder, 9·4^{cm}; pressure of the gas (air), 74·7^{cm} of Hg. The variation of the constants, *a*, and *b*, when the sign of the discharge is reversed, is, in the case of air, not large; but in case hydrogen is used a very large difference exists.

The equation given above seems applicable to the discharge under all the various conditions of the gas. Even after the gas had suffered any amount of "deterioration," so that the discharge that passed was decidedly less, the relation between potential and current still exists,—with different values for the constants, *a* and *b*.

5. The applicability of this relation at widely different gas pressures (varying from 20^{cm} to 80^{cm} of Hg.) was also established. The variation of the discharge current, with gas pressure, for a given apparatus, does not seem capable of any simple formulation. It seems probable that this was due to a difference in the rate and extent of the deterioration of the gas at the different pressures, so that the constants obtained represent different conditions of the gas, beside differences of pressure. The constants obtained are :

Pressure.	<i>a</i> .	<i>b</i> .
20 ^{cm} of Hg.	3·55	3·20
40 " "	1·05	8·53
75 " "	·55—·65	11·7—12·2

The dimensions of the apparatus were those given in the preceding section.

6. For determination of the law of the variation of current with the radius of the cylinder, three cylinders of suitably different radii, with discharge wires of the same size and length, were mounted as the one used heretofore. Hydrogen, generated from hydrochloric acid with zinc, purified and dried by the usual process, was passed into the cylinders in place of air, as this gas shows less rapid deterioration with continued use. Still, under the most favorable conditions that could be obtained, the current given by a certain potential was subject to considerable variation.

It was found that to a certain degree of approximation, the total discharge current is inversely proportional to the cube of the radius of the cylinder, other dimensions being the same. It is to be noticed that this relation holds most accurately when the current in the cylinders compared is of the same order of magnitude. It seems probable that the deviation which occurs when the current in one tube is large compared to that in the other may be due to more rapid deterioration of the gas with increased discharge; in fact, the deviation is always most pronounced when the discharge is largest in both tubes.

A typical series of observations is given below: the lengths of the discharge wires were each 10^{cm} ; the radii of the cylinders were 5.0^{cm} , 3.2^{cm} and 1.5^{cm} respectively; that of the discharge wire was 0.0034^{cm} .

TABLE III.

Applied potentials. in volts.	Current.			Ratios.	
	I_1 for $r = 5.0.$	I_2 for $r = 3.2.$	I_3 for $r = 1.5.$	$\frac{I_2}{I_1}$	$\frac{I_3}{I_2}$
3500	4.0	16.0	152.	4.0	9.5
3800	----	24.	200.	----	8.3
4000	9.0	36.	290.	4.0	8.0
4500	19.	74.	480.	3.9	6.5
5000	31.	118.	----	3.8	----
5500	55.	189.	----	3.4	----
		Mean values,		3.82	8.1

The ratios r_1^3/r_2^3 and r_2^3/r_3^3 have the values 3.8 and 9.7, respectively. The variations obtained were usually within the limit of those shown in this series.

7. In résumé, then, it has been found that the current discharging from a fine wire to a concentric surrounding cylinder is given by the equation,—

$$I = \frac{L}{r^3} aV(V-b)$$

where,

I = the discharge current

V = the potential difference between wire and cylinder

L = length of the discharge wire

r = radius of the cylinder

b = the minimum potential necessary to produce a measurable discharge,

and, a = a constant depending upon the size of the wire, t the discharging gas, and the sign of the discharge.

Physical Laboratory,
University of Nebraska, May, 1901.

ART. XIX. — *On Octahedrite and Brookite, from Brindletown, North Carolina*; by H. H. ROBINSON.

THE two minerals described in this article were kindly sent to Prof. S. L. Penfield by Mr. W. E. Hidden, and are from the original locality on the north slope of Pilot Mountain near Brindletown, Burke County, North Carolina, discovered by him in 1879.* They occur, according to Mr. Hidden, in detached crystals scattered through the gold-bearing gravels of the district, having been derived from the disintegration of the local schists. As accompanying minerals, are mentioned zircon, monazite, xenotime, samarskite, fergusonite, and many others.

It was thought that brief descriptions, with figures, of these two minerals would be of interest both because of their rare occurrence in the United States and because no careful investigation of the crystals from this locality seems to have been made.

1. *Octahedrite.*

The crystals studied vary in size from 2 to 5^{mm} in diameter on the horizontal axes and from 0.50 to 1.25^{mm} in thickness. The larger ones are of a deep bluish-black color and then they possess a metallic-adamantine luster, while a smaller one is quite colorless. Under the microscope, the color is seen to be due to a dark pigment which entirely pervades some crystals, while in others transparent spots are left, around the borders of which the pigment gradually fades out. A small transparent crystal, representing a section perpendicular to the vertical axis, was dark in all positions between crossed nicols. In converging polarized light, however, it was seen that the mineral was not perfectly uniaxial, as the axes of the interference figure opened slightly on revolving the section.

In habit the crystals are tabular owing to the prominent development of the basal pinacoid, $c(001)$. This Mr. Hidden mentions as being the common habit. The simplest crystal examined consists of the forms $c(001)$, $e(101)$, $x(103)$, and $p(111)$, and is shown by figures 1*a* and 1*b*; of these, 1*a* is a horizontal projection (on c) and 1*b* shows the crystal in the usual perspective.† In figures 2*a* and 2*b* a slightly more com-

* This Journal (3), xxi, 160, 1881.

† In this article the method has been adopted of giving with each clinographic drawing of the crystals a plan, which represents a true horizontal projection of the lower figure. In most cases the drawing of such a plan greatly facilitates the construction of the customary crystal figure, giving a complete control over it, and the two figures taken together give a better idea of the crystal shape than either one alone. Since there exists the closest relationship between the two figures, it has been considered advisable to represent them in the position in which they are drawn. Accordingly each plan is shown as revolved a certain angle (18° 26′) from a horizontal position.

plex combination is represented with two additional faces, o (107) and v (117). These two figures show all the prominent forms as well as their relative development.

The complete list of faces observed is as follows :

c (001)	o (107)	γ (902)	v (1·1·28)
e (101)	d (301)	p (111)	ρ (1·1·40)
x (103)	u , (5·0·19)	v (117)	

The errors in the measured values of the above faces as compared with the values given by Dana* range from 1' to 10', the average being $3\frac{1}{2}'$. Though most of the faces give rather poor reflections, the measurements are all close enough to clearly establish their identity.

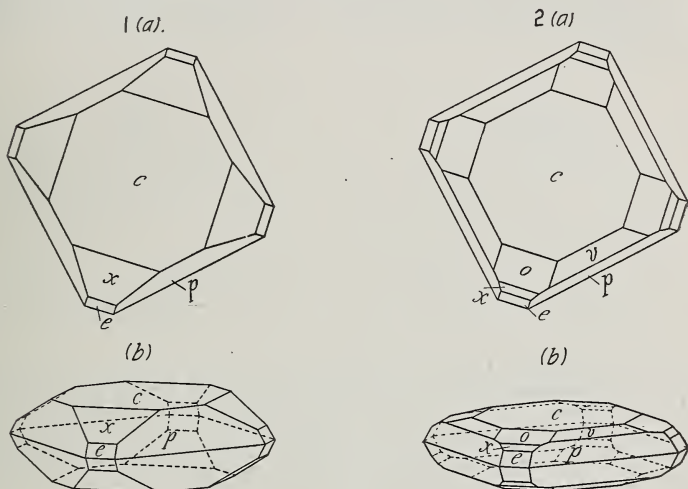

The form v (1·1·28) was first observed by Seligmann,† who identified it with but moderate certainty, owing to the poor development of the faces on the crystals examined by him. The angles measured on two of these crystals leave no doubt as to the correctness of the indices established by him, as is shown by the following :

	Calculated.	Measured (I).	Average.	Measured (II).	Average.
$c \wedge v$,	$5^\circ 7\frac{3}{4}'$	$5^\circ 3'$		$5^\circ 10'$	$5^\circ 11'$
		$5 12$	$5^\circ 7\frac{2}{3}'$	$5 12$	
		$5 8$			

The above measurements and the fact that the face lies in the zone $c \wedge p$ are sufficient to establish the identity of this

* System of Mineralogy, 6th ed., 1892, 240.

† Zs. Kr., ii, 337, 1886.

form. The faces are all of small size, yet the measurements from five give an average error of but $1\frac{1}{4}'$. On one crystal three out of the possible four forms were observed at one extremity, on a second only two.

2. Brookite.

Five crystals of this mineral were examined and they are of special interest because they possess a habit quite different from that ordinarily observed.

The habit of all the crystals is prismatic. Their development on the a and b axes is well shown in the plans of figures 3-6. The length in the direction of the vertical axis is from four to six times their greatest width. Being relatively so long and slender, it did not seem best to represent them as doubly terminated.

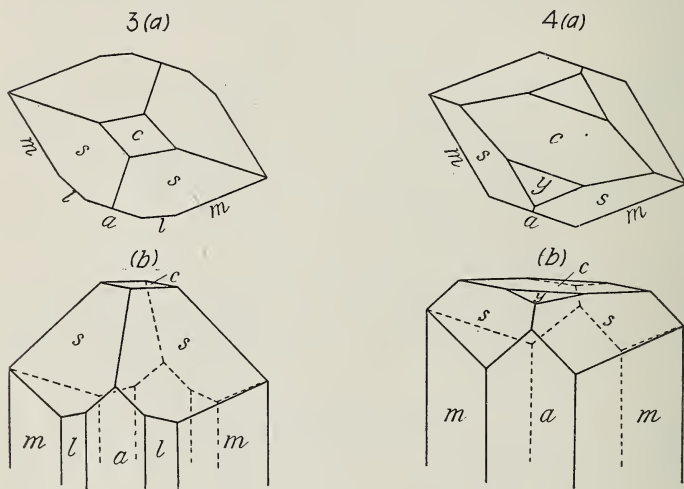

The unusual feature of these crystals is the prominent development of the pyramid s (322). This form was first observed by Kokscharow* as a very small face, and the only notice of its having a prominence at all like that on the crystals from this locality is in an article by Streuver, "Sulla Brookite di Buera nell'Ossola."† The habit of the crystals described by him is, however, quite different in that it is short and tabular parallel to a (100), the proportion between the width and thickness being as $1 : \frac{1}{8}$.

* Vh. Min. Ges., St. Petersburg, 1848-49.

† Proc. R. Acc. d. Linc. (4), vi, 77, 1890.

Figures 3*a* and 3*b* show the simplest type, the crystal being terminated by the single pyramid *s* (322) in combination with a small basal pinacoid. In figures 4*a* and 4*b*, *s* (322) is in combination with a dome *y* (104) and a much larger basal plane. Figures 5*a* and 5*b* show the pyramids *e* (122) and *z* (112), which are common on brookite, about equal in their development to

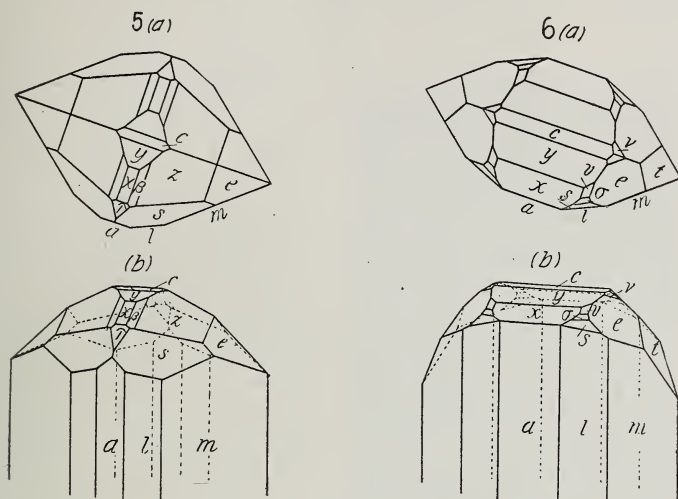

s (322). The pyramid β (5·4·10) is new, occurring, as shown, as a narrow face in a zone with *e*, *z*, and *x*. Of the domes, *y* (104) and *x* (102) are common, while τ (101) is new. In figures 6*a* and 6*b* the general habit is more like that ordinarily observed in brookite, the domes *y*, *x*, and *t*, and the pyramid *e* all being common forms. The pyramid *s* (322), σ (324), and *v* (326) are in a zone and σ (324) is new. The pyramid *v* (146) is also new. In the prismatic zone *a* (100), *m* (110), and *l* (210) are largely developed, while *a* (320) and *k* (410) are present as narrow faces.

All the crystals are of small size, ranging from 1·25 to 2·50^{mm} in width, 0·75 to 1·75^{mm} in thickness, and 3 to 7^{mm} in length. Their color is a dark reddish-brown and renders them too opaque for optical examination in natural sections. Vertical striations on the prismatic faces, with the exception of *m*, are always very marked, giving them a dull luster. The terminal faces are all somewhat striated, though not sufficiently to greatly injure the quality of the larger ones.

The faces observed, with their measurements as made on a two-circle goniometer and their calculated values, are given in

the following table. The scheme is that of Goldschmidt as given in his "Krystallographische Winkeltabellen."

Faces.	Measured.		Calculated.		Error.	
	ϕ	ρ	ϕ	ρ	ϕ	ρ
<i>c</i> (001)	---	---	---	---	---	---
<i>a</i> (100)	89° 58'	89° 58'	90° 0'	90° 0'	2'	2'
<i>m</i> (110)	49 55	" "	49 55	" "	0	2
<i>a</i> (320)	60 50	" "	60 42	" "	8	2
<i>l</i> (210)	67 13	" "	67 10	" "	3	2
<i>k</i> (410)	77 52	" "	78 07	" "	15	2
<i>d</i> (043)	----	51 28	----	51 32	--	4
<i>t</i> (021)	----	62 0	----	62 06	--	6
<i>y</i> (104)	89 57	15 37	90 0	15 40	3	3
<i>x</i> (102)	" "	29 15	" "	29 18	3	3
τ (101) (new)	" "	48 18	" "	48 17½	3	0½
ν (146) "	16 30½	33 23½	16 32½	33 18	2	5½
<i>e</i> (122)	30 47	47 38	30 43	47 41	4	3
<i>z</i> (112)	49 53	36 12	49 55	36 15	2	3
<i>o</i> (111)	49 54	55 47	" "	55 43	1	4
β (5·4·10) (new)	55 55	34 05½	56 03	34 04½	8	1
<i>v</i> (326)	60 43	32 44	60 42	32 45	1	1
σ (324) (new)	60 46½	43 49	" "	43 59	4½	10
<i>s</i> (322)	60 42	62 35	" "	62 36	0	1
Average error,					3¾	3

In calculating the values of the four new forms given in the foregoing table the axial ratio of $a:\bar{b}:c=0.84158:1:0.94439$, as determined by Kokscharow,* was used. The form β (5·4·10) was observed on one crystal (figure 5), three faces being present on one end and two on the opposite, out of a possible four in each case. The dome τ (101) was observed but once on the same crystal. The pyramids σ (324) and ν (146) were observed on but one crystal (figure 6), the first form being represented by two and the second by three faces.

Sheffield Laboratory of Mineralogy,
Yale University, New Haven, Conn., May, 1901.

* Mineralogie Russlands, I, 61, 1853.

ART. XX. — *On the Behavior of Small closed Cylinders in Organ-pipes*; by BERGEN DAVIS, Ph.D.

WHILE experimenting with stationary sound waves in organ-pipes, the following striking effect was obtained. A considerable number of small gelatine capsules, such as are used for medical purposes, were thrown in a promiscuous pile in the center of the pipe, and when the pipe was blown so as to give its first overtone quite strongly, the small cylinders immediately moved to the middle of the loop of the stationary wave and there arranged themselves in rows across the pipe as shown in the figure. The spacing between the rows was quite regular and the capsules acted as though there was a strong attraction at their ends, in a direction perpendicular to the vibration, and a repulsion at their sides in a direction parallel to the vibration.

An investigation was undertaken to determine the effect of the size of the cylinders, of the number of rows, and of the amplitude of vibration, upon the distances between the rows.

The stationary wave was that produced in a stopped organ-pipe speaking its first overtone. The side of the pipe was removed and a glass plate substituted for it. At the node nearest the mouth a thin rubber diaphragm was placed across the pipe, which protected the portion back of the diaphragm from disturbances arising from blowing. This region of the pipe, from the diaphragm to the stopped end, enclosed one-half of the stationary wave. The amplitude of vibration was measured by means of the force acting on a small hollow cylinder closed at

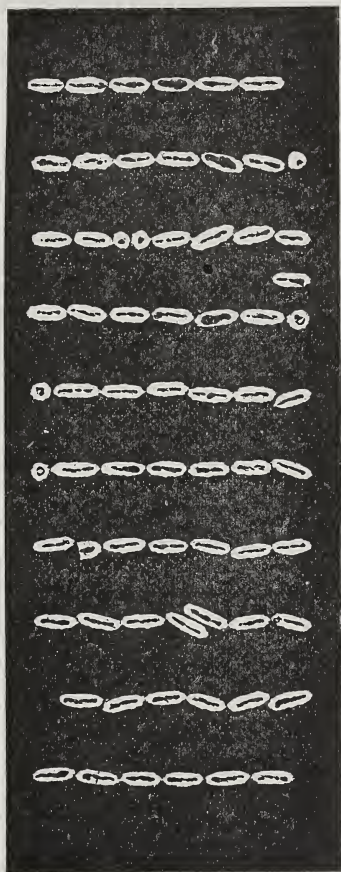

one end, as was described by the writer in this Journal.* The torsion balance carrying this cylinder was placed at the middle of the loop.

The small cylinders whose spacing in the sound wave was to be measured were of two kinds, consisting of small gelatine capsules and of paper tubes. These two kinds of cylinders were used in independent series of experiments.

Three sizes of gelatine capsules were used, commercial numbers of which are Nos. 00, 2 and 5.

The dimensions in centimeters of these cylinders are given below.

	Length.	Diameter.
No. 00 -----	2.42	.83
No. 2 -----	1.75	.63
No. 5 -----	1.03	.48

A sufficient number of one of the above sizes of capsules were placed in the organ-pipe to form a considerable number of rows. In order to obtain a desirable amplitude of vibration the torsion head was turned from the zero position by an amount corresponding to a desired amplitude, then the pressure of blowing was increased until the force acting on the measuring device just balanced the torsion previously given to the wire; at the same time the capsule cylinders arranged themselves in rows across the pipe. This previous setting of the torsion head enabled me to reproduce the same amplitude of vibration at will.

In the tables below are given the average distances in centimeters between the rows for the various sizes, with increasing amplitudes of vibration. The amplitude $2A$ is here used to denote the total excursion of the vibrating air particles.

<i>No. 00. Capsule cylinders.</i>				
Amplitudes.	Number of rows.			
2A	2	3	6	10
.39	4.	3.5	2.8	2.2
.434	3.5	3.3	2.6	2.1
.476	3.3	3.5	2.6	2.1
.548	3.5	3.7	2.7	2.2
<i>No. 2. Capsule cylinders.</i>				
Amplitudes.	Number of rows.			
2A	2	3	6	10
.39	2.8	2.75	2.8	2.
.434	2.4	2.5	2.65	1.95
.476	2.5	2.5	2.55	2.
.548	2.5	2.5	2.45	2.

* This Journal, September, 1900.

Amplitudes.	No. 5. Capsule cylinders.			
	Number of rows.			
2A	2	3	6	10
·39	2·	2·75	2·4	1·9
·434	1·8	2·5	2·1	1·55
·476	2·	2·1	2·1	1·6
·548	2·	2·5	2·2	1·66

The most striking result obtained from the above tables is that the distances between rows slightly decrease with increasing amplitudes of vibration. The average distance between the rows decreases in general as the number of rows increases, excepting in the case of the smallest, No. 5 cylinders, in which case the spacing increased when three and six rows were used. This tendency to increase with these particular rows is also exhibited by the No. 2 cylinders. The general rule may also be deduced, that the larger the cylinders, the more the spacing decreases with the number of rows, as will be evident by comparing the two-row and the ten-row columns in the three tables. At the higher amplitudes the capsule cylinders were quite violently agitated, as though the position of the loop were somewhat unsteady, which increased the difficulties of accurate measurement.

The corresponding experiments were performed with paper cylinders of various diameters. These cylinders were each 6·3^{cm} in length and were open at both ends, on account of the circumstance that the length of one of them was nearly equal to the diameter of the pipe. Since the effect to be observed was a result of the forces acting at the sides and not at the ends, the open ends did not affect the experiment. The open ends were of advantage in that they lessened the force with which the cylinders in all cases adhered to the walls of the pipe.

The diameters of these cylinders in centimeters are given below :

No. 1	·5
No. 2	·71
No. 3	1·00
No. 4	1·4

These paper cylinders were introduced into the closed chamber of the pipe and the same experiments performed as with the capsule cylinders. Each cylinder now corresponds to a row as described in the previous experiments. The same amplitudes of vibration were retained for the purpose of comparison. The results are given in the following tables :

No. 1. *Paper cylinders.*

Amplitudes.	Number of rows.			
	2	3	6	10
2A				
·39	3·2	3·2	2·6	2·1
·434	2·6	3·2	2·5	1·9
·476	2·3	3·2	2·5	1·9
·548	2·3	3·2	2·4	1·9

No. 2. *Paper cylinders.*

Amplitudes.	Number of rows.			
	2	3	6	10
2A				
·39	6·5	3·	2·7	2·3
·434	6·	3·	2·8	2·3
·476	6·	3·2	2·9	2·2
·548	6·	3·2	2·8	2·2

No. 3. *Paper cylinders.*

Amplitudes.	Number of rows.			
	2	3	6	10
2A				
·39	6·	4·3	3·9	2·
·434	5·5	4·	3·	2·
·476	5·	4·	----	----
·548	5·	4·	----	----

No. 4. *Paper cylinders.*

Amplitudes.	Number of rows.			
	2	3	6	10
2A				
·39	7·	5·5	3·3	2·8
·434	6·5	5·	----	----
·476	6·5	----	----	----
·548	----	----	----	----

Here again it will be noticed that the space between the cylinders slightly decreases with increasing amplitudes of vibration. The space between the rows decreases as the number of rows increase. This result is somewhat different from that obtained with the No. 2 and No. 5 capsule-cylinders, while the same result was obtained as with the large No. 00 capsule-cylinders. The blanks in the columns with the larger cylinders when several rows were used, are due to the fact that the tone passed over into the next overtone before the required amplitude was reached. This was probably due to the effect of friction. The presence of so much obstruction tended to form a node at this point, which is near the natural

position of the node of the next overtone. When this overtone occurred, the rows would divide into two portions, which moved toward the middles of the two loops of the new stationary wave.

A striking effect was obtained by placing a number of the smallest capsule-cylinders a short distance from the node. When the pipe spoke, they immediately ran rapidly to the middle of the loop, and there assumed a regular arrangement.

The effects described in this paper are of course of the same nature as the Kundt dust figures. The individual capsule-cylinders may be considered as dust particles in which the size has been much increased, the particles still remaining light enough to respond readily to the delicate forces to which they are subjected.

Prof. Rood suggested as an explanation of the spacing that a sound-shadow is formed on the two sides of the cylinders at each half vibration, alternately. These shadows, being regions of less motion, press so to speak against the cylinders. When there are two rows the shadows between the cylinders press them apart until the force just equals that pressing against the outside or nodal sides of the two cylinders. This also explains their rapid movement from the nodes toward the loop. The average velocity on the side nearest a node is less, and hence the pressure greater than on the side nearest a loop, where the velocity is greater. The behavior of the capsule-cylinders illustrates the distribution of the forces acting upon rigid bodies in moving fluids, the mathematical analysis of which has been so fully developed by W. Koenig.*

The effect here described can be easily reproduced as a lecture experiment. The ordinary stopped organ-pipe found in lecture cabinets will suffice for the purpose. The smaller capsules will perhaps be found to give the effect more strongly in case the pipe is not a powerful one.

Physical Laboratory of Columbia University, June 1, 1901.

* Wied. Ann., xlii, pp. 353, 549, 1891.

ART. XXI.—*On a Cæsium-Tellurium Fluoride*; by H. L. WELLS and J. M. WILLIS.

SEVERAL tellurium double fluorides have been described: $\text{NaF}\cdot\text{TeF}_4$ by Berzelius, $\text{KF}\cdot\text{TeF}_4$, $\text{NH}_4\text{F}\cdot\text{TeF}_4$ and $\text{BaF}_2\cdot 2\text{TeF}_4\cdot\text{H}_2\text{O}$ by Högbom.* It is noticeable that all these fluorides belong to a type which is different from that of the double chlorides, bromides and iodides of tellurium, e. g., $2\text{KCl}\cdot\text{TeCl}_4$, $2\text{RbBr}\cdot\text{TeBr}_4$ and $2\text{CsI}\cdot\text{TeI}_4$, etc., which have been thoroughly studied in this laboratory by Wheeler.† We have undertaken, therefore, an investigation of the combination of cæsium fluoride with tellurium fluoride, with the expectation that possibly several types of double fluorides might be obtained. After a systematic examination of the matter, however, we were able to prepare only one double fluoride, $\text{CsF}\cdot\text{TeF}_4$, which corresponds in type to the previously known fluorides.

A concentrated solution of TeF_4 was prepared by dissolving about 10^g of pure TeO_2 in an excess of strong hot hydrofluoric acid, and to this cæsium fluoride was added in small portions, the liquid being concentrated by evaporation and cooled after each addition. At the same time small portions of tellurium fluoride were added to a concentrated solution of about 50^g of cæsium fluoride in hydrofluoric acid and this solution was evaporated and cooled in the same manner. Under the widest range of conditions, however, only a single double salt was obtained.

1 : 1 Cæsium-tellurium fluoride, CsF·TeF₄.—This salt crystallizes beautifully in large, transparent, colorless needles. The presence of free hydrofluoric acid is necessary for its formation, for it is decomposed by water. Several crops, made under widely varying conditions, were analyzed with the following results:

	Calculated for CsTeF_6 .	Found.			
		I.	II.	III.	IV.
Cæsium	37·36	36·59	37·50	38·56	37·23
Tellurium	35·96	35·51	36·45	35·82	35·60
Fluorine	26·68	26·76	24·51	26·18	----

Fluorine was determined volumetrically by converting it into SiF_4 , collecting this in water, and titrating with a standard solution of potassium hydroxide. In another portion, after evaporating with concentrated sulphuric acid and dissolving the residue in hydrochloric acid, tellurium was precipitated with sulphur dioxide, collected on a Gooch crucible and weighed as metal. From the filtrate from the tellurium cæsium was obtained, and weighed as normal sulphate.

Sheffield Scientific School, May, 1901.

* Bulletin, xxv, 60.

† This Journal (3), xlv, 267.

ART. XXII.—On the Double Chlorides of Cæsium and Thorium; by H. L. WELLS and J. M. WILLIS.

NEARLY all of the known double halogen salts of quadrivalent metals belong to a single type, of which $2\text{KCl}\cdot\text{PtCl}_4$ and $2\text{KF}\cdot\text{SiF}_4$ are examples. It has been shown, however, by Marignac* and by Wells and Foote† that the double fluorides of zirconium exist in a variety of types. Therefore, since thorium is somewhat closely related to zirconium, we have undertaken an investigation of some thorium double halides, and have selected the cæsium salts as being the most promising.

Upon attempting to prepare cæsium thorium fluorides we found that thorium fluoride is practically insoluble even in concentrated solutions of cæsium fluoride containing hydrofluoric acid. There is no doubt that the two fluorides combine under these circumstances, but since we obtained only finely divided precipitates as products and there was no certainty as to their purity, further work on the fluorides was abandoned. Chydenius‡ has previously described two potassium thorium fluorides, $2\text{KF}\cdot\text{ThF}_4\cdot 4\text{H}_2\text{O}$ and $\text{KF}\cdot\text{ThF}_4\cdot\frac{1}{2}\text{H}_2\text{O}$, but on account of the insolubility of thorium fluoride and of these double salts it is probable that there may be some doubt in regard to the correctness of these formulæ.

We have prepared two cæsium-thorium chlorides, to which we assign the formulæ $3\text{CsCl}\cdot\text{ThCl}_4\cdot 12\text{H}_2\text{O}$ and $2\text{CsCl}\cdot\text{ThCl}_4\cdot 11\text{H}_2\text{O}$. The amount of water of crystallization in these compounds is somewhat uncertain, since they form very small hygroscopic crystals, and it is difficult to dry them by pressing on paper. The search for double chlorides was made systematically by starting with a solution of about 65^g of thorium chloride in hydrochloric acid, adding 2 to 4^g of cæsium chloride at a time, and evaporating and cooling after each addition until finally, after dividing the solution and using a part of it, a very large excess of cæsium chloride was present.

In analyzing the salts, chlorine was determined as silver chloride, sometimes in separate portions, in other cases in the filtrates from which thorium hydroxide had been precipitated; thorium was weighed as oxide after precipitation with ammonia, and the cæsium in the filtrates was converted into normal sulphate and weighed as such; water was determined by difference.

* Ann. Chim. Phys. (3), lx, 257.

† This Journal (4), i, 18; iii, 466.

‡ Pogg. Ann., cxix, 43.

3 : 1 Cæsium-thorium chloride, $3\text{CsCl}\cdot\text{ThCl}_4\cdot 12\text{H}_2\text{O}$.—This salt was produced from solutions containing about 12^g of thorium chloride and from 30 to 110^g of cæsium chloride. It forms colorless crystals of feathery structure upon cooling very concentrated solutions. Three different crops made under somewhat varied conditions gave the following results upon analysis :

	Calculated for $\text{Cs}_3\text{ThCl}_7\cdot 12\text{H}_2\text{O}$.	I.	Found. II.	III.
Cæsium	36.45	36.21	36.14	----
Thorium	21.20	20.70	21.68	21.05
Chlorine	22.61	23.09	----	23.37
Water	19.74	[20.00]	----	----

2 : 1 Cæsium-thorium chloride, $2\text{CsCl}\cdot\text{ThCl}_4\cdot 11\text{H}_2\text{O}$.—This salt was obtained in colorless crystals, somewhat resembling the previous salt, but not nearly as feathery in appearance. It was formed in concentrated solutions containing about 65^g of thorium chloride and from 30 to 100^g of cæsium chloride. The following analyses were made of different crops :

	Calculated for $\text{Cs}_2\text{ThCl}_6\cdot 11\text{H}_2\text{O}$.	I.	Found II.	III.	IV.
Cæsium	29.26	29.84	29.10	28.92	----
Thorium	25.52	25.42	25.41	25.70	25.22
Chlorine	23.43	23.40	24.75	23.35	23.55
Water	21.78	[21.34]	[20.74]	[22.03]	----

The salt loses water slowly in the desiccator over sulphuric acid. A sample dried in this way lost 6 per cent in two days, 11 per cent after one week, and 20 per cent, corresponding to practically all the water, after one month.

The two chlorides that we have obtained are different in type from the potassium salt $\text{KCl}\cdot 2\text{ThCl}_4\cdot 18\text{H}_2\text{O}$ described by Cleve* and from the ammonium salt $8\text{NH}_4\text{Cl}\cdot\text{ThCl}_4\cdot 8\text{H}_2\text{O}$ described by Chydenius.† It seems certain that the ammonium salt just mentioned represents a mixture, for it is described as a sintered mass made in the dry way.

Sheffield Scientific School, May, 1901.

* Bulletin, xxi, 118.

† Pogg. Ann., cxix, 43.

ART. XXIII.—*Studies of Eocene Mammalia in the Marsh Collection, Peabody Museum; by J. L. WORTMAN.*

[Continued from p. 154.]

Hind limb.—The greater part of the pelvic bones of both sides are present, from which an accurate idea of this portion of the osteology can be formed. In comparison with the ilium, the ischium, figure 32, is elongate, being 73 per cent of the length of the former bone; in *Herpestes* it is 79, in *Crossarchus* 69, in the Binturong 66, and in the domestic cat 65 per cent of the length of the ilium. The peduncular portion of the ilium exhibits about the same degree of constriction as that seen in the Binturong, and is somewhat greater than in *Herpestes*. The gluteal surface is little expanded, and is occupied by two longitudinal grooves separated by a prominent rounded ridge; of these the superior is the wider and deeper, the inferior being long and narrow. This division of the gluteal surface is a characteristic feature of the pelvis of all Eocene Carnivora, and in some species it persists into the Oligocene. In the living forms, it has very generally disappeared, only a trace of it remaining in some of the less specialized types. The meaning of its universal presence in the early types is to be accounted for on the supposition that the primitive

31



FIGURE 31.—Phalanx of *Oödictes herpestoides* Wortman; dorsal view; two and one-fourth times natural size. (Type.)

32

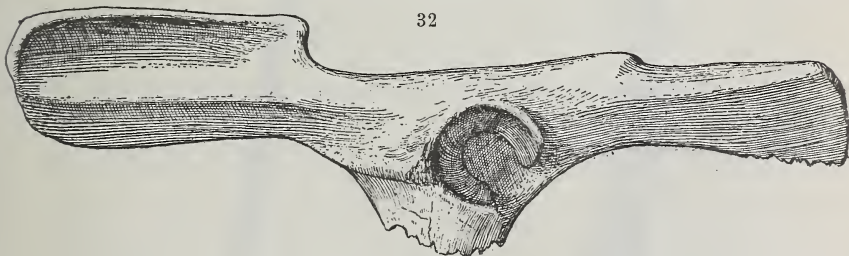

FIGURE 32.—Portion of left half of pelvic girdle of *Oödictes herpestoides* Wortman; side view; three halves natural size. (Type.)

Marsupial-like ancestors had a type of ilium similar to that of the living Opossum, in which it consists of a simple elongated trihedral bar attached to a single vertebra. Slight expansion of the dorsal and ventral borders of this bar would give the conditions seen in the Eocene types, wherein the longitudinal ridge corresponds to and is the remains of the primitive bar.

A little in front of, and below the acetabulum is a relatively large rugose area, which served to give origin to the *rectus femoris*; it is rather large and this part of the bone somewhat

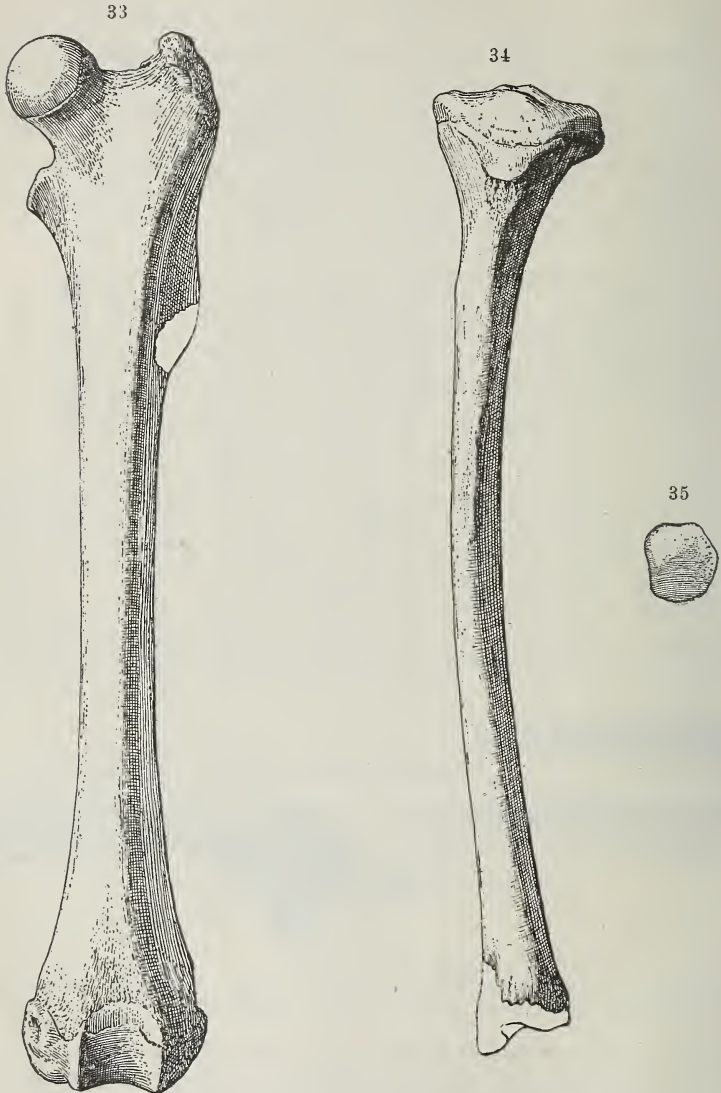

FIGURE 33.—Left femur of *Oödectes herpestoides* Wortman; front view.

FIGURE 34.—Left tibia of same species; front view.

FIGURE 35.—Left patella of same species; front view.

All figures are three halves natural size. (Type.)

deep, resembling in this respect the corresponding part of the pelvis of the Binturong. The ischial tuberosities were little developed, as in the *Ichneumon*, and there is but slight indication of the ischial spine.

The femur, figure 33, is relatively stout and has a straight shaft. The hemispherical head is set upon the shaft by a short, thick neck, and the *fovea capitalis* for the terete ligament is distinct. The *trochanter major* rises to the level of the head, and the digital fossa is deep, narrow, and slit-like, as if it had been compressed from before backwards, as in certain of the carnivorous Marsupials, notably the *Dasyures* and *Oposums*. The *trochanter minor* is broad and placed upon the inner side of the shaft just below the neck. The distal end of the bone is characteristic, being relatively broad and flat. The condyles are well separated and have comparatively little posterior extension; they are sub-equal in size, and the inner is not produced downwards to any perceptibly greater extent than the outer. The rotular groove is broad and shallow and has but slight upward extension upon the anterior surface of the shaft. In all its characters, with the exception of the third trochanter and the large size of the *trochanter minor*, the femur bears a very strong resemblance to that of the Binturong, and differs from the viverrine and herpestine representatives in the character of the distal end, the shape of the greater trochanter, and the position of the lesser, which is more on the inner border of the shaft. The patella, figure 35, moreover, is short, flat, thin, and scale-like, having more the shape of that of the Binturong, in marked contrast to its narrow, elongate, thickened form in the other sections of the family.

The tibia, figure 34, does not closely resemble that of any of the living *Viverridæ* on account of the preponderance of primitive characters which it possesses. These are seen in the relatively small size, the slender and rounded shaft, its great lateral curvature, and the small development of the cnemial crest. The head has the appearance of being flattened from before backwards; the two tuberosities have the usual form, but the spine is very much less divided than in the modern species. The entire form is quite as much like that of the Marsupials as that of the living types. Near the middle of the shaft or what may be taken as the extreme lower end of the cnemial crest is seen a prominent roughened area for tendinous attachment. This area is also pronounced in the tibia of many Marsupials; and is likewise present, but less strongly marked, in the Binturong. If it served for the attachment of the tendon of one of the inner hamstring muscles, which is in all probability the case, it indicates an unusually low position for this insertion. A short distance above, and to the inner side, is seen the point of insertion of

the remaining tendons of the inner hamstring. The distal end is unknown.

With the exception of some fragments of the middle portion of the shaft, the fibula is not preserved. These fragments indicate that it was comparatively little reduced, a character which again takes it back towards a Marsupial stage of development.

The pes is represented by but a few inconsiderable fragments, which do not, unfortunately, serve to give a very clear idea of its organization. A distal extremity of a calcaneum corresponds much more nearly with that of the Binturong than either *Herpestes*, *Crossarchus*, *Viverra*, or *Eupleres*. The articular surface for the cuboid is rather flat, the astragalar facet much arched, and the sustentaculum widely projecting, with a slightly excavated facet. There was apparently no contact between the fibula and calcaneum. The cuboid has about the same relative height as is found in the viverrines in general; but in correspondence with the flat distal end of the calcaneum its proximal surface is likewise considerably flattened. The navicular again exhibits a very decided resemblance to that of the Binturong, and differs sharply from the viverrine, herpestine, and euplerine sections of the family. In the Binturong, the posterior margin of the bone is divided by a deep notch or sulcus into two sub-equal projections. In *Herpestes*, *Crossarchus*, and *Eupleres*, no such sulcus exists, and the postero-internal angle is enlarged and elevated. In the fossil this sulcus is present, but not so deep as in the Binturong, yet the arrangement is essentially the same. No other part of the pes is known. The principal measurements are as follows:

Length of three posterior premolars and first two superior molars	18· mm
Length of superior sectorial	5·
Transverse diameter of superior sectorial	3·8
Length of first and second molars (outside) ...	6·7
Transverse diameter of first molar (anterior) ..	5·8
Transverse diameter of first molar (posterior) ..	5·9
Transverse diameter of second molar (anterior) ..	5·5
Transverse diameter of second molar (posterior) ..	4·5
Length of inferior dental series from anterior border of canine	30·5
Length of first lower molar	4·5
Length of second lower molar	3·7
Depth of jaw at anterior border of first molar ..	8·2
Length of centrum of third (?) lumbar vertebra ..	15·
Length of centrum of last lumbar vertebra ...	15·
Length of centrum of penultimate lumbar vertebra	17·

Length of centrum of axis including odontoid	16· mm
Length of centrum of third cervical	8·
Length of humerus	68·5
Transverse diameter of humerus (distal end)	16·5
Length of ulna (estimated)	71·
Length of radius	58·
Length of carpus and metacarpus (estimated)	24·
Length of phalanx, second row	10·
Length of pelvis	74·
Transverse diameter of ilium	12·
Length of femur	92·
Transverse diameter of proximal extremity	16·5
Transverse diameter of <i>caput femoris</i>	8·3
Transverse diameter at lesser trochanter	15·
Transverse diameter of distal extremity	16·
Antero-posterior diameter of condyles	12·
Length of patella	6·
Transverse diameter of patella	6·8
Length of tibia (estimated)	81·5
Transverse diameter of head of tibia	14·5
Antero-posterior diameter of head of tibia	11·

Discussion.—In the foregoing description of this family, frequent reference has been made to their relationship with the Viverridæ, the characters in which the two families resemble as well as differ from each other have been pointed out as far as they are known, and the position has been generally assumed that the one stands in direct ancestral relation to the other. I will now proceed to summarize the arguments upon which this assumption is based, but it is first necessary to observe that the idea is by no means a new one. Professor Marsh, in giving the name *Viverravus* to the species first described, expressed this relationship, although he did not follow it up with the necessary evidence to establish it upon a firm foundation. In my work on the "Comparative Anatomy of the Teeth" (1886), I gave utterance to the same view, but did not attempt a demonstration of the same. Flower and Lydekker, in "Mammals Living and Extinct," 1891, p. 539, state: "The North American genera *Miacis* and *Didymictis* (*Uintacyon* and *Viverravus*) are generally regarded as representing a separate family—Miacidæ—with affinities to both the Viverridæ and the Canidæ." In our paper on "The Ancestry of Certain Members of the Canidæ, the Viverridæ, and Procyonidæ" (Bull. Amer. Mus., 1899), Matthew and myself reiterated this opinion, and from a study of the skeleton of a species of *Viverravus* brought forward some evidence in its support.

From a consideration of the materials at present before us, it may be regarded as clearly established that there were at

least two generic types living in this country during the deposition of the Bridger sediments, the sum total of whose characters, as far as they can be at present ascertained, come nearer to the living Viverridæ than to any other known group of the Carnivora. These characters, moreover, not only do not interpose any difficulties in the way of deriving the one group from the other by direct descent, but they furnish just such a combination of resemblances and differences as we should be reasonably led to look for on *a priori* grounds, in the Eocene ancestors of the existing Viverridæ. The living representatives of this family include three and perhaps four widely divergent types, so different from each other that at various times they have been considered by some very good authorities to represent distinct family modifications. One of these, the Viverrinæ, for which there are excellent reasons to believe that they come nearest to the original stem form, has fossil representatives in the Upper Eocene of Europe, whose remains are indistinguishable generically from those living to-day. This fact indicates a most remarkable persistence or stability of structure which we are not at liberty to suppose began abruptly in the Upper Eocene, but must have, in some degree at least, belonged to its earlier Eocene progenitors. Now it is either a striking coincidence or a highly significant fact that this very character is one of the preëminently distinguishing features of *Viverravus*. We have already seen that it passes with but very little change from the Torrejon to the Bridger inclusive, or, in other words, it did not change more than specifically during the deposition of between six and seven thousand feet of sediment. There is another fact which must not be lost sight of just here, and that is, that in the Eastern Hemisphere these forms appear abruptly in the upper stages of the Eocene, while in the Western Hemisphere they disappear quite as suddenly in the age preceding. So much, then, for the general considerations touching the possible relationship of the two groups.

Let us next inquire into the special or particular resemblances and differences which they present. In the *Viverravus-Viverra* series we note, (1) that the dental formula is identically the same in the two groups; (2) that the structure of the various teeth, including all the details of arrangement with respect to the component cusps, ridges, etc., is surprisingly similar; (3) that the skull of *Viverravus* exhibits the same more or less compressed, post-orbitally elongated form as that of the Viverrinæ; (4) that the atlas has the same arrangement of the perforations for the passage of the vertebral artery—a highly characteristic viverrine feature; (5) that the succeeding vertebræ are very similar in the two groups, including the long and powerful tail, which is still retained;

and (6) that there is such a general similarity in the structure of the limbs that one could easily have been derived from the other.

The main points of difference are not of a fundamental character, but relate to the assumption of modernized features, such as (1) increase in size of the brain; (2) development of tympanic into a large, two-chambered, otic bulla, with consequent modification of the contiguous cranial foramina and paroccipital process; (3) decrease in relative size of the lumbar vertebræ; (4) reduction in size of the deltoid crest of the humerus; (5) union of the scaphoid, lunar, and centrale of the carpus; (6) loss of third trochanter of the femur, and reduction in size of the lesser trochanter; (7) development of cnemial crest of tibia, and (8) grooving of astragalus and loss of fibular contact with the calcaneum. These characters, as we know from so many other lines, pertain to all the primitive Carnivora, and involve just such parts of the osteological structure as have been profoundly and progressively modified by development. Instead, therefore, of offering any difficulties in the way of the derivation of the Viverrinæ from *Viverravus*, they are of such a nature as one would reasonably assume to belong to the primitive type. The evidence, then, in favor of this derivation, as it at present stands, is strongly presumptive if not absolutely demonstrative. If well founded, it establishes for this phylum an antiquity greater than that of any group of living Carnivora thus far known.

The position of the genus *Oödetes* with reference to the living forms is not so clear. The possession of three true molars in the superior and inferior series would hardly have been expected in a Bridger representative, seeing that in *Viverravus* they had already been reduced to the modern formula as early as the Torrejon. The genus, therefore, can clearly have nothing whatever to do with the ancestry of the *Viverra* series. That it is viverrine in its affinities, however, is so strongly suggested by almost every feature of its structure that it cannot be consistently placed in any other group. Among living forms, it seems to bear a more decided resemblance to certain of the Paradoxures than to any other section of the family, although the relatively short, thick premolars, with the disposition to the development of internal cusps, recall very forcibly certain members of the Herpestinæ. This character, however, is also found in the Paradoxures. In the inferior premolars it is important to note that in their lack of development of a distinctively trenchant and sectorial character, they are well fitted to give rise to the various types of teeth of this group, even including members the most aberrant and highly modified in this respect; as *Aretogale* and *Arctictis*. Indeed, the skeletal parts, as far as they are preserved, show many significant resemblances to the Binturong. These are

especially noticeable in the ulna, femur, patella, navicular, calcaneum, and cuboid. These resemblances, however, may be accidental and deceptive, and until we can connect the two groups somewhat more closely in point of time, their relations cannot be regarded as finally settled.

In this connection I wish to draw attention to three genera described by Professor Marsh from various fragmentary materials (mostly teeth and portions of jaws), the validity of which is either questionable or the remains are insufficient to indicate their true position. They are as follows:

Triacodon fallax Marsh.*

The type of this genus and species, figure 36, consists of the anterior portion of a tooth crown of the first lower molar or sectorial, which agrees in every particular with the corresponding tooth of *Viverravus gracilis*. I therefore do not hesitate to refer it to this species. Professor Marsh erroneously supposed that it was an entire tooth of the premolar series, and this at first sight would seem possible, since the broken surface where the heel joins the trigon is worn in such a way as more or less to conceal the fracture. I give herewith a cut of the tooth seen from the inside.



FIGURE 36.—A right lower sectorial of *Triacodon fallax* Marsh; inside view; natural size. (Type.)

A second species, *T. grandis*,† was also described by Professor Marsh, and this again is founded upon the trigon of a sectorial molar of some larger species of Carnivore, presumably *Limnocyon verus*, although the specimen agrees equally well with some other species, notably *Sinopa agilis*. A third species, *T. nanus*, is of the same character, and is referable to some small carnivorous or insectivorous species.

Ziphaeodon rugatus Marsh.‡

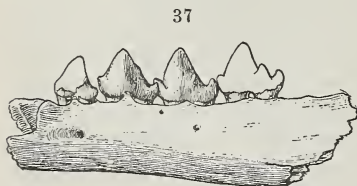

FIGURE 37.—Left lower jaw of *Ziphaeodon rugatus* Marsh; outside view; three halves natural size. (Type.)

This genus and species was established upon the anterior portion of a lower jaw, figure 37, carrying the second and third premolars with the roots of the first and fourth, together with the alveolus for the canine and a part of that for the first incisor. As far as one is able to judge, this jaw fragment agrees perfectly with *Viverra-*

* This Journal, vol. ii, August, 1871, p. 15, separata.

† This Journal, vol. iv, August, 1872, p. 32, separata.

‡ This Journal, vol. iv, August, 1872, p. 25, separata.

vus gracilis. The principal points of similarity are seen in the two-rooted first premolar, which is characteristic of all the Bridger species of *Viverravus*, the form of the premolars, and the agreement in size. The name may, therefore, I think, be properly placed as a synonym of *V. gracilis*.

Harpalodon sylvestris Marsh.*

This small species of Carnivore was founded upon a fragment of a left lower jaw, figure 38, supporting the third and fourth premolars and a part of the crown of the first molar or sectorial, including the complete heel. The structure of the premolars agrees most nearly with those of *Uintacyon edax*. The heel of the sectorial is somewhat less trenchant, having the inner portion slightly developed so as to form an incipient basin. The jaw is broken below so as not to display its character very well, yet it has the appearance of being much more slender, though lacking the thick heavy structure of this latter species. When more fully known, this may prove to be a distinct form. With the present material, however, I am persuaded that the best course to pursue is to place it in the doubtful list, since there are no characters by which it can be properly placed or distinguished.

A second species of this genus, *H. vulpinus*, founded upon a lower jaw fragment, figure 39, containing the last premolar, I think clearly belongs to *Viverravus gracilis*, and I have no hesitancy in placing it in this category.

Family *Palaeonictidae* Osborn and Wortman.

Palaeonictidae Osborn and Wortman, Bull. Amer. Mus. Nat. Hist., vol. iv, no. 1, 1892.

A family of little known, primitive Carnassidents placed ancestral to the Felines, ranging in time from the Wasatch to the Bridger inclusive, and characterized by the early and rapid reduction of the molar dentition, the short face, and cat-like lower jaw.

Of this family, three genera are known, of which *Palaeonictis* comes from the Wasatch of Europe and America, *Amblyctonus* from the Wasatch of New Mexico, and *Elurotherium* from the Bridger.

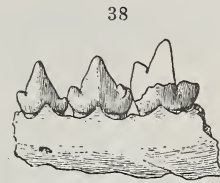

FIGURE 38.—Portion of left lower jaw of *Harpalodon sylvestris* Marsh; outside view; three halves natural size. (Type.)

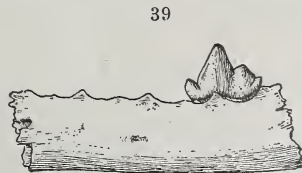

FIGURE 39.—Fragment of left lower jaw of *Harpalodon vulpinus* Marsh; outside view; three halves natural size. (Type.)

* This Journal, vol. iv, August, 1872, p. 25, separata.

A well-preserved anterior portion of a skull of *Palæonictis americanus* was secured by the writer in the Wasatch horizon of the Big Horn Basin, in 1891, which formed the basis of the description of this species and is the best specimen of the group thus far recovered. *Amblyctonus* is known from a few fragmentary remains of teeth and jaws only. No other skeletal parts have been found.

Ælurotherium latidens Marsh.

Limnofelis latidens Marsh, this Journal, vol. iv, August, 1872; *Patriofelis leidyana* Osborn and Wortman, Bull. Amer. Mus., vol. iv, no. 1, 1892; *Patriofelis leidyana* Wortman, Bull. Amer. Mus., 1894, p. 164; *Ælurotherium leidyana* Adams, this Journal, June, 1896, p. 442.

Professor Marsh, in describing *Limnofelis latidens*, states: "A second very large Carnivore, but inferior to the preceding

40

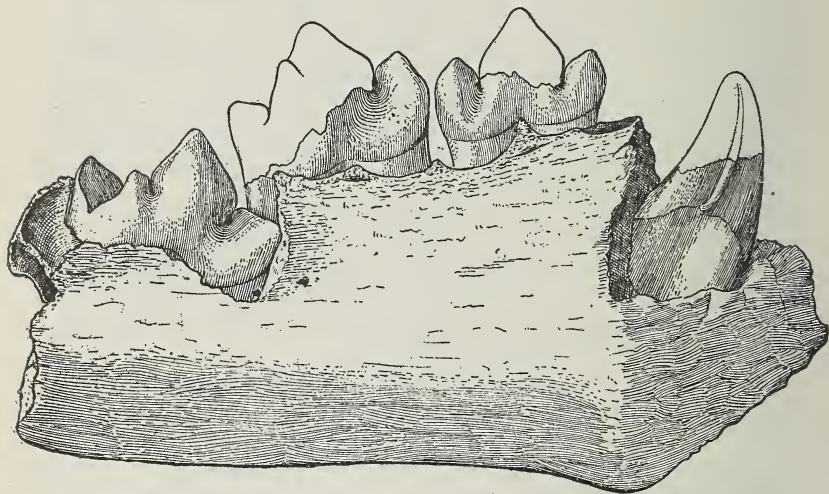

FIGURE 40.—Left lower jaw, with milk teeth and first permanent molar, of *Ælurotherium latidens* Marsh; inside view; three halves natural size. (Type.)

in size, is indicated by a last upper premolar and probably by some other fragmentary remains. . . . Another specimen apparently of this species is a left lower jaw of a young individual. It contains the canine and three (four) molars, the last of which is still nearly enclosed in the jaw." It is now evident that the fourth premolar above mentioned belongs to *Patriofelis ferox*, which was previously described by Professor Marsh; and that the second specimen, or that of the immature individual, figures 40, 41, is a member, not only of

another genus, but another family. It is therefore the type of the genus and species under consideration. The specimen consists of an incomplete mandibular ramus containing the deciduous canine, second and third deciduous molars, the alveolus for the first, and the crown of the first permanent molar, which was just being erupted. Immediately posterior to this tooth is seen a part of the bony crypt which lodged the imperfectly calcified germ of a second molar, so that the inferior molar and premolar formula can be determined. The three deciduous molars imply a like number of permanent premolars, and as there is evidence of no more than two molars, we may fairly assume that the number was two. The formula would then be I. (?), C. $\bar{1}$, Pm. $\bar{3}$, M. $\bar{2}$.

The deciduous canine was not fully erupted and the point of the crown is missing. Like the corresponding milk tooth of the lion, the root is considerably compressed from side to side and of great antero-posterior diameter. The crown is small in comparison with the root, and the enamel extends much further down on the buccal than upon the lingual side of the crown. There is a deep vertical sulcus, flanked by a distinct ridge in front, on the inner face, the base of the crown, which is surrounded by a distinct cingulum.

The first deciduous molar, as indicated by its alveolus, is placed behind the canine without diastema, somewhat internal to the tooth line and slightly overlapping the second tooth. The tooth was small and single-rooted. The second tooth is abruptly larger; it is implanted by two strong roots and has a crown composed of a large, laterally compressed, central cusp, with strong anterior and posterior cusps. There is no basal cingulum. In structure, this tooth agrees very closely with that of the lion.

The crown of the third deciduous molar is much damaged and does not display its structure satisfactorily. Enough remains, however, to enable me to state that its crown was thoroughly sectorial in organization. The anterior blade is preserved and is rather short antero-posteriorly. The great proportional length which remains indicates without much doubt that there was a rather large heel and probably an internal cusp as well. In the milk sectorial of the lion both these elements are present; and as far as this tooth is preserved in the fossil, its resemblance to that of the cats is much more marked than it is to any other family of the Carnassidentia.

41



FIGURE 41. — Crown view of first lower molar of *Aelurodon latidens*; three halves natural size. (Type.)

As a whole, the milk dentition of the fossil differs from that of both the Canidæ and the Viverridæ in having three instead of four milk molars; from the Hyænidæ in the larger canine, the small, single-rooted first molar, and the development of three strong cusps on the second. In the hyæna, the first deciduous molar is large and two-rooted, and the anterior basal cusp on the second is rudimental or wanting. As far, however, as we are able to judge, in its imperfectly preserved condition, it agrees perfectly with that of the cats.

The crown of the sectorial is of much interest, inasmuch as it exhibits a stage of development intermediate between that of *Palæonictis* of the Wasatch and *Dinictis* of the Oligocene. The three usual cusps of the trigon are present, but they are flattened and their edges drawn out to a much greater extent than in any other Carnassident of its time. The internal cusp is relatively small, has a very posterior position, and there is no evidence that the posterior shear between it and the anterior edge of the first superior molar was functional, which leads to the conclusion that this latter tooth was considerably reduced. The heel is composed of a single, rather large trihedral cusp, with the anterior edge produced forwards toward the base of the trigon, thus very strongly foreshadowing the trenchant heel of the corresponding tooth of *Dinictis*, *Nimravus*, and so many other Felines of the Oligocene and Miocene.

As already noted, a part of the bony crypt which served to lodge the germ of a second molar is to be seen just posterior to the sectorial. Aside from the important fact of demonstrating the existence of a second molar, it furnished the further information that this tooth was much reduced in size, which is of still greater moment. The jaw has greater vertical depth in front than behind, the symphysis is large, but there is no trace of a flange as in *Dinictis*. Altogether it may be remarked that it is just such a type as preceded that of the Sabre-tooth Tigers.

The measurements are as follows :

Length from anterior base of canine to posterior part of first permanent molar	59 mm
Length of second and third deciduous molars	33
Length of first permanent molar	18.5
Depth of jaw at first deciduous molar	32
Depth of jaw behind first permanent molar...	23.5

This important type specimen was found by Mr. G. M. Keasby of the Yale party of 1871, in the Henry's Fork Bad Lands of the Bridger Basin, Wyoming.

Elurotherium bicuspis sp. nov.

A second species of this genus is indicated by a first lower molar or sectorial tooth, figures 42, 43, of the left side. It is somewhat smaller than this tooth in *E. latidens* and differs further from it in the possession of two cusps on the heel instead of one, which gives it a more decidedly basin-shaped



FIGURE 42.—Left lower sectorial molar of *Elurotherium bicuspis* Wortman; outside view. (Type.)

FIGURE 43.—Crown view of same.

Both figures are three halves natural size.

character. Of the two cusps comprising the heel the larger is median and the smaller is external. This species is more closely allied to *Palæonictis*, in which the heel of the first lower molar is tubercular.

The principal measurements are as follows:

Antero-posterior diameter	16.8 ^{mm}
Transverse diameter.....	8.5
Height of crown at middle cusp.....	12.

The specimen was found by L. LaMothe on Henry's Fork, Bridger Basin, Wyoming.

Discussion.—Doubtless some objection will be raised to the placing of this family in the Carnassidentia, and did we have the genus *Palæonictis* alone to consider, it could be possibly regarded as a more or less questionable procedure, since the development of the fourth superior premolar and the first inferior molar into highly specialized carnassial teeth, to the exclusion of all the others, had not reached quite that degree of perfection displayed by either the contemporaneous viverrine or canine phylum; but at the same time, the tendency in this direction was so clearly evident as to leave no room for doubt that the genus should be arranged with those forms which finally developed the typical sectorial dentition of the modern Carnassidentia. There seems, moreover, to be entire unanimity of opinion that *Elurotherium* is not only a member of the Palæonictidæ, but is the direct descendant of

Palaeonictis. If this is true—and it would seem to be a very probable assumption from the evidence thus far obtained*—it then follows that the whole series are true Carnassidents, since the first lower molar of the Bridger species is practically as well developed and as exclusively a sectorial as it is in any of the Oligocene Felids.

The genetic relationship of *Ælurotherium* to the Oligocene Felidæ is a matter of the greatest moment, for the reason that, if once established, it gives us the long sought key to the solution of the problem of feline ancestry. Although the material upon which our knowledge at present rests is scarce and fragmentary, and the evidence correspondingly meager and incomplete, yet such as this affords appears to be of neither an indifferent character nor uncertain significance. We have already seen (1) that the milk dentition of the lower jaw is surprisingly feline in the make-up; (2) that the molar and premolar formula for the inferior series is the same as in certain of the Oligocene types, notably *Dinictis*; (3) that the structure of the molars and premolars coincides almost exactly with those forms, and (4) that the form of the lower jaw exhibits unmistakable evidences of relationship. The specimens do not afford any evidence whatever of a contrary nature, and until such is forthcoming we must look upon this source of feline origin as not only possible but extremely probable.

If the conclusions herein set forth are well founded, it follows that in the Bridger epoch there were clearly established three of the main lines of modern Carnassident descent, a fact which in itself implies an origin at a much earlier date. Indeed, as the evidence accumulates we are forced to conclude that the beginnings of these phyletic lines are incomparably more ancient than we had formerly thought possible.

* See Ancestry of the Felidæ, Bull. Amer. Mus. Nat. Hist., 1892, p. 94, in which I fully discussed this subject.

[To be continued.]

ART. XXIV.—*On the Separation of the Least Volatile Gases of Atmospheric Air, and their Spectra*; by G. D. LIVEING, M.A., Sc.D., F.R.S., Professor of Chemistry in the University of Cambridge, and JAMES DEWAR, M.A., LL.D., F.R.S., Fullerman Professor of Chemistry, Royal Institution, London.

[Read before the Royal Society of London, June 20, 1901.]

OUR last communication to the Society* related to the *most* volatile of the atmospheric gases; that which we now beg leave to offer relates to the *least* volatile of those gases. The former were obtained from their solution in liquid air by frac-

1

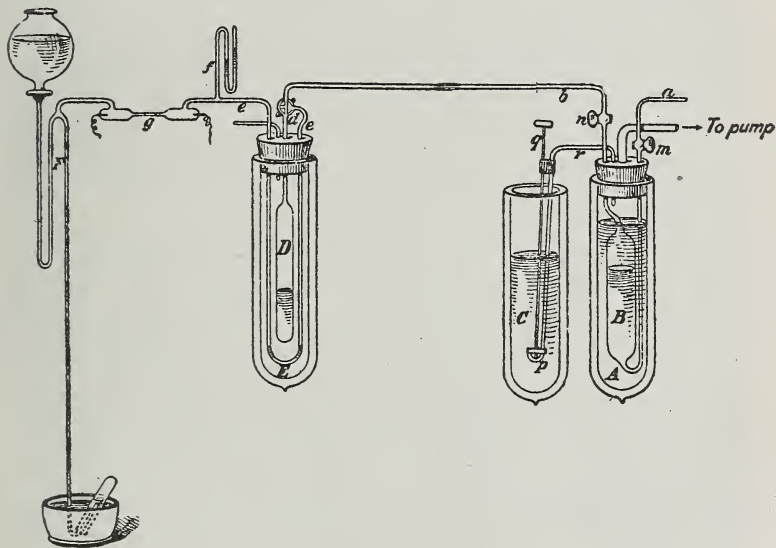

tional distillation at low pressure, and separation of the condensable part of the distillate by cooling it in liquid hydrogen. The latter were, in the first instance, obtained from the residue of liquid air, after the distillation of the first fraction, by allowing it to evaporate gradually at a temperature rising only very slowly. The diagram, fig. 1, will make the former process intelligible. *A* represents a vacuum-jacketed vessel, partly filled with liquid air, in which a second vessel, *B*, was immersed. From the bottom of *B* a tube, *a*, passed up

* Proc. Roy. Soc., vol. lxxvii, p. 467; this Journal, xi, 154.

through the rubber cork which closed *A*, and from the top of *B* a second tube, *b*, passed through the cork and on to the rest of the apparatus. Each of these tubes had a stopcock, *m* and *n*, and the end of tube *a* was open to the air. A wider tube also passed through the cork of *A* and led to an air-pump, whereby the pressure above the liquid air in *A* was reduced, and the temperature of the liquid reduced by the consequent evaporation. To keep the inner vessel, *B*, covered with liquid, a fourth tube, *r*, passed through the cork, and its lower end, furnished with a valve, *p*, which could be opened and closed by the handle *q*, dipped into liquid air contained in the vessel *C*. As the pressure above the liquid in *A* was less than that of the atmosphere, on opening the valve *p* some of the liquid air was forced through *r* into *A* by the pressure of the atmosphere, and in this way the level of liquid in *A* maintained at the required height.

Since *B* was maintained at the temperature of liquid air boiling at reduced pressure, the air it contained condensed on its sides, and when the stopcock *n* was closed and *m* opened more air passed in through the open end of *a*, and was in turn condensed. In this way *B* could be filled completely with liquid air, the whole of the most volatile gases being retained in solution in the liquid.

The tube *b*, passing from the top of *B*, was connected with a three-way stopcock *d*, by which it could be put in communication with the closed vessel, *D*, or with the tube *e*, and by which also *D* and *e* could be connected. The tube *e* passed down nearly to the bottom of the vacuum-jacketed vessel *E*, and out again through the cork; and so on to a gauge *f*, and through a sparking tube *g* to a mercury pump *F*.^{*} The stopcock *n* being still closed, the whole of the apparatus between *n* and the pump, including the vessel *D*, was exhausted, and liquid hydrogen introduced into *E*. The three-way cock *d* was then turned so as to connect *b* with *D*, and close *e*, and then *n* opened. *B* was thereby put in communication with *D*, which was at a still lower temperature than *B*, and the gas dissolved in the liquid in *B*, along with some of the most volatile part of that liquid, distilled over, and the latter condensed in a solid form in *D*. When a small fraction of the liquid in *B* had thus distilled, the stopcock *d* was turned so as to close the communication between *D* and *b* and open that between *D* and *e*. Gas from *D* passed into the vacuum tubes, but in so doing it had to pass through the portion of *e* which was immersed in liquid hydrogen, so that condensible matter carried forward by the stream of gas was frozen out.

^{*} The Sprengel in figure is simply diagrammatic.

For separating the least volatile part of the gases, the vessel *E*, with its contents, was dispensed with, and the tube *b* made to communicate directly with that connected with the gauge, sparking tube, and pump; and generally several sparking tubes were interposed between the gauge and pump, so that they could be sealed off successively. The bulk of the liquid in *B* consisted of nitrogen and oxygen. These were allowed gradually to evaporate, the temperature of *B* being still kept low so as to check the evaporation of the gases less volatile than oxygen. When a great part of the nitrogen and oxygen had thus been removed, the stopcock *n* was closed, and the tubes partially exhausted by the pump, electric sparks passed through *g*, and the gases examined spectroscopically. More gas was then evaporated from *B*, and the spectroscopic examination repeated from time to time.

The general sequence of spectra, omitting those of nitrogen, hydrogen, and compounds of carbon, which were never entirely removed by the process of distillation alone, was as follows: The spectrum of argon was first noticed, and then as the distillation proceeded the brightest rays, green and yellow, of krypton appeared, and then the intensity of the argon spectrum waned, and it gave way to that of krypton until, as predicted by Runge, when a Leyden jar was in the circuit, the capillary part of the sparking tube had a magnificent blue color, while the wide ends were bright pale yellow. Without a jar the tube was nearly white in the capillary part, and yellow about the poles. As the distillation proceeded, the temperature of the vessel containing the residue of liquid air being allowed to rise slowly, the brightest of the xenon rays began to appear, namely, the green rays about λ 5420, 5292, and 4922, and then the krypton rays soon died out and were superseded by the xenon rays. At this stage the capillary part of the sparking tube is, with a jar in circuit, a brilliant green; and is still green, though less brilliant, without the jar. The xenon formed the final fraction distilled.

Subsequently an improved form of apparatus was used for the fractionation. It is represented in fig. 2. A gasholder containing the gases to be separated, that is to say, the least volatile part of atmospheric air, was connected with the apparatus by the tube *a*, furnished with a stopcock *c*. This tube passed on to the bulb *B*, which in turn communicated through the tube *b* and stopcock *d* with a sparking tube, and so on through the tube *e*, with a mercurial pump. Stopcock *d* being closed and *c* opened, gas from the holder was allowed to pass into *B*, maintained at low temperature, and there condensed in the solid form. Stopcock *c* was then closed and *d* opened, and gas from *B* allowed to pass into the exhausted tubes between

B and the pump. The tube *e* was partly immersed in liquid air in order to condense vapor of mercury, which would otherwise pass from the pump into the sparking tube. The gas passing into the sparking tube would, of course, have a pressure corresponding to the temperature of *B*, and this was further ensured by making the connecting tube pass through the liquid in which *B* was immersed. The success of the operation of separating all the gases which occur in air and which boil at different temperatures depends on keeping the

2

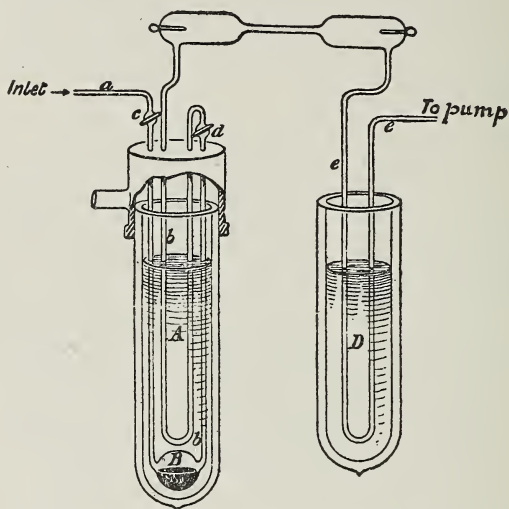

temperature of *B* as low as possible, as will be seen from the following consideration:—

The pressure p , of a gas G , above the same material in the liquid state, at temperature T , is given approximately by the formula

$$\log p = A - \frac{B}{T},$$

where A and B are constants for the same material. For some other gas G' the formula will be

$$\log p_1 = A_1 - \frac{B_1}{T},$$

and

$$\log \frac{p}{p_1} = A - A_1 + \frac{B_1 - B}{T}.$$

Now for argon, krypton, and xenon respectively the values of A are 6.782, 6.972, and 6.963, and those of B are 339, 496.3,

and 669.2; so that for these substances and many others $A - A_1$ is always a small quantity, while $\frac{B_1 - B}{T}$ is considerable and increases as T diminishes. Hence the ratio of p to p_1 increases rapidly as T diminishes, and by evaporating all the gases from the solid state and keeping the solid at as low a temperature as possible, the gas first coming off consists in by far the greatest part of that which has the lowest boiling point, which in this case is nitrogen, and is succeeded, with comparative abruptness, by the gas which has the next higher boiling point. The change from one gas to another is easily detected by examining the spectrum in the sparking tube, and the reservoirs into which the gases are pumped can be changed when the spectrum changes, and the fractions separately stored. Or, if several sparking tubes are interposed in such a way as to form parallel communications between the tubes b and e , any one of them can be sealed off at any desired stage of the fractionation.

The variation of the spectra of both xenon and krypton with variation in the character of the electric discharge is very striking, and has already been the subject of remark, in the case of krypton, by Runge, who has compared krypton with argon in its sensitiveness to changes in the electric discharge. Runge distinguishes krypton rays which are visible without a jar and those which are only visible with a jar discharge. The difference in the intensity of certain rays, according as the discharge is continuous or oscillatory, is no doubt very marked, but, with rare exceptions, we have found that the rays which are intensified by the oscillatory discharge can be seen with a continuous discharge when the slit of the spectroscope is wide. Runge used a grating, whereas we have, for the sake of more light, used a prism spectroscope throughout, and were therefore able to observe many more rays.

There is one very remarkable change in the xenon spectrum produced by the introduction of a jar into the circuit. Without the jar xenon gives two bright green rays at about λ 4917 and λ 4924, but on putting a jar into the circuit they are replaced by a single still stronger ray at about λ 4922. In no other case have we noticed a change so striking as this on merely changing the character of the discharge. Changes of the spectrum by the introduction of a jar into the circuit are, however, the rule rather than the exception, and there are changes in the spectrum of krypton which seem to depend on other circumstances. In the course of our examination of many tubes filled with krypton in the manner above indicated, we have found some of them to give with no jar the green ray λ 5571, the yellow ray λ 5871, and the red ray λ 7600 very

bright, while other rays are very few, and those few barely visible. Putting a jar into the circuit makes very little difference; the three rays above mentioned remain much the brightest, nearly, though not quite, so bright as before, and the blue rays, so conspicuous in other tubes, though strengthened by the use of the jar, are still very weak. In other tubes the extreme red ray is invisible; the rays at λ 5571 and 5871 absolutely, as well as relatively, much feebler, while the strong blue rays are bright, even brighter than the green and yellow rays above named. In one tube the blue rays could be seen, though not the others. This looks very much as if two different gases were involved, but we have not been able to assure ourselves of that. The case seems nearly parallel with that of hydrogen. There are some hydrogen tubes which show the second spectrum of hydrogen very bright, and others which show only the first spectrum; the second spectrum is enfeebled or extinguished by introducing a jar into the circuit, while the first spectrum is strengthened; and the conditions which determine the appearance of the ultra-violet series of hydrogen rays have not yet been satisfactorily made out.

It is to be noted that putting the jar out of circuit does not in general immediately reduce the brightness of the rays which are strengthened by the jar discharge. Their intensity fades gradually, and is generally revived, more or less, by reversing the direction of the current, but this revival gets less marked at each reversal until the intensity reaches its minimum. The rays strengthened by the jar discharge also sometimes appear bright, without a jar, on first passing the spark when the electrodes are cold, and fade when the electrodes get hot, reappearing when the tube has cooled again. Moreover, if the discharge be continued without a jar, the resistance in the krypton tubes increases rather rapidly, the tube becomes much less luminous and finally refuses to pass the spark. With an oscillatory discharge the passage of the spark and the brightness of the rays are much more persistent. This seems to point to some action at the electrodes, which is more marked in the case of krypton than in that of xenon.

The wave-lengths of the xenon and krypton rays in the tables below were determined, in the visible part of the spectrum, with a spectroscope having three white flint-glass prisms of 60° each, by reference to the spark spectrum of iron, except in the cases of the extreme red ray of krypton, which was referred to the flame spectrum of potassium, and its fainter neighbor, which we saw but did not measure. The indigo, violet, and ultra-violet rays were measured in photographs, taken with quartz lenses and two calcite prisms of 60° each. The spectrum of the iron spark was photographed at the same time as

that of the tube, the former being admitted through one-half of the slit, and the latter through the other half.

The xenon spectrum is characterized by a group of four conspicuous orange rays of about equal intensities, a group of very bright green rays of which two are especially conspicuous, and several very bright blue rays. The only list of xenon rays we have seen is that published by Erdmann, with which our list does not present any close agreement except as to the strongest green lines. The number of xenon rays we have observed is very considerable, and some of them lie very near to rays of the second spectrum of hydrogen, but inasmuch as these rays are more conspicuous with a jar in circuit than without, which is not the character of the second spectrum of hydrogen, and, moreover, many of the brightest of the hydrogen rays are absent from the spectrum of the tubes, we conclude that these rays are not due to hydrogen. Certain rays, which we have tabulated separately, have been as yet observed in only one tube: they include a very strong ultra-violet ray of unknown origin, and due either to some substance other than xenon, or to some condition of the tube which has not been repeated in the other tubes.

Our krypton rays agree much more closely with Runge's list, but outnumber his very considerably, as might be expected when prisms were used instead of a grating. Prisms, of course, cannot compete with gratings in the accuracy of wave-length determinations. We think that the krypton used by Runge must have contained some xenon, and that the rays for which he gives the wave lengths 5419.38, 5292.37, and 4844.58 were really due to xenon, as they are three of the strongest rays emitted by our xenon tubes, and are weak in, and in some cases absent from, the spectra of our krypton tubes.

Tables of the approximate Wave-lengths of Xenon and Krypton Rays.

Rays observed only with a Leyden jar in circuit have a * prefixed, those observed only when no Leyden jar was in circuit have a † prefixed.

The intensities indicated are approximately those of the rays when a jar is in circuit, except in the case of the two rays to which a † is prefixed, which are not seen when a jar is in circuit. Rays which are equally intense whether a jar is in circuit or not have a || prefixed to the number indicating their intensities; those which are less intense with a jar than without have a < prefixed to the number expressing their intensities. The rest are, in general, decidedly more intense with a jar than without.

Xenon Rays.

Wave-length.	Intensity.	Wave-length.	Intensity.	Wave-length.	Intensity.	Wave-length.	Intensity.
*6596	4	5025	<1	4286	3	3870	2
* 14	1	4988	4	72	3	62	2
6472	1	72	2	69	3	58	2
6358	1	+ 24	†4	63	2	55	1
45	3	* 22	8	51	3	50	2
20	1	† 17	†4	45	10	49	1
02	1	4890	3	39	8	42	4
6278	3	87	—	27	1	29	1
71	3	84	4	23	5	26	1
6183	1	83	—	15	10	24	1
81	1	76	4	14	6	15	1
66	1	44	10	09	8	11	3
6097	6	30	1	04	1	07	1
51	6	23	3	01	1	01	1
36	5	* 18	3	4198	1	3792	1
5976	6	07	<1	93	6	87	1
72	—	4793	1	81	10	83	1
46	2	87	2	76	1	81	6
35	<1	79	2	72	1	76	3
06	1	69	2	63	3	73	1
5895	1	40	1	59	3	70	1
76	1	34	<1	46	3	66	1
56	1	31	1	42	1	63	2
25	2	23	1	32	2	62	1
17	—	14	1	21	1	57	1
5777	4	4698	3	12	2	46	3
59	4	4677	band of close lines	09	6	37	1
51	5	to		06	3	31	2
27	4	4668		4000	2	21	3
20	4	52	4	99	3	17	2
00	6	34	2	93	1	12	2
5668	4	24	<2	79	<1	08	1
60	1	16	3	74	1	3689	1
17	—	02	8	60	1	77	3
09	1	4592	3	58	6	73	2
5583	1	86	5	50	6	64	1
73	1	77	3	44	1	62	2
32	4	56	2	43	1	58	1
5473	3	45	3	37	6	55	2
61	3	41	3	29	1	50	1
* 51	1	35	2	25	3	45	6
39	3	25	5	21	1	41	2
20	10	22	1	3902	3	32	2
5372	6	00	1	94	2	24	10
* 68	1	4486	1	91	3	16	1
39	6	81	5	86	1	13	4
13	1	71	2	81	1	10	2
09	1	62	10	75	1	07	4
5292	10	49	6	73	2	02	1
62	2	40	1	57	1	3597	8
60	2	34	2	55	4	84	8
40	—	15	8	51	<6	80	8
27	1	07	3	44	3	65	4
02	1	4396	4	39	1	56	3
5192	6	93	4	26	1	53	5
89	3	86	3	23	6	43	6
85	3	75	4	15	1	23	4
79	3	69	4	08	4	10	2
26	3	56	1	06	1	04	1
23	1	43	1	3803	1	01	4
07	3	37	3	94	3	3468	2
5080	2	31	10	85	3	61	1
68	5	22	3	80	3	54	1
52	1	11	3	77	3		
45	6	4297	3				

Wave-lengths of rays of unknown origin observed in the spectrum of one tube containing xenon but not present in the spectrum of other tubes:—

Wave-length.	Intensity.	Wave-length.	Intensity.	Wave-length.	Intensity.	Wave-length.	Intensity.
4589	—	4063	—	3890	1	3741	4
4071	1	11	1	72	1	3684	10
67	1	3998	1	3797	5	3573	2

Krypton Rays.

Wave-length.	Intensity.	Wave-length.	Intensity.	Wave-length.	Intensity.	Wave-length.	Intensity.
7600	8	5186	1	4387	3	3859	1
†7587	2	72	1	76	3	58	1
6771	1	66	5	63	2	47	1
6578	1	43	4	56	12	44	2
42	3	26	6	23	2	42	1
11	2	5087	3	20	8	39	1
6487	3	78	1	19	3	37	2
58	<1	73	2	18	3	17	2
51	3	57	3	01	7	06	2
20	<4	34	1	4293	10	05	3
6305	3	23	4	83	3	3784	10
6170	2	14	2	74	4	79	8
6095	1	4980	1	69	3	72	4
82	1	60	1	60	1	59	2
56	2	46	1	56	1	55	6
21	1	03	2	51	5	46	6
11	2	4847	2	37	4	42	6
5992	3	45	2	4185	3	36	3
5873	1	* 33	5	72	1	34	4
71	<10	26	3	45	8	22	5
5771	2	12	3	40	2	19	10
53	2	4766	10	4119	3	15	1
5690	5	63	3	09	6	3691	1
82	5	39	10	4099	8	87	5
50	1	4694	3	89	8	81	7
32	2	80	5	65	7	70	7
5571	<10	59	8	58	6	67	1
63	3	50	1	45	4	64	3
53	1	35	6	38	2	61	3
44	1	20	8	08	2	54	10
23	2	15	6	05	1	49	3
06	2	10	3	3997	3	38	4
00	2	4598	1	94	6	32	10
5483	1	93	2	88	2	24	1
46	2	83	4	65	1	08	6
29	1	77	8	55	2	00	6
24	1	25	3	39	1	3590	3
03	1	05	2	28	3	74	1
5319	1	4490	2	21	8	54	2
05	1	75	6	18	2	45	6
5278	1	64	3 pair	13	6	03	2
29	1	54	1	07	6	3489	2
18	1	37	6	01	1	70	1
15	1	32	6	3896	3	60	3
* 09	5	23	2	76	7		
03	1	00	1	62	1		

† This is taken from Runge's number for the wave-length omitting the fraction.

ART. XXV.—*The Estimation of Calcium, Strontium, and Barium, as the Oxalates*; by CHARLES A. PETERS.

[Contributions from the Kent Chemical Laboratory of Yale University—CI.]

A FORMER article from this laboratory* describes the conditions under which oxalic acid may be titrated by potassium permanganate in the presence of hydrochloric acid, and states that the extra consumption of permanganate which ordinarily takes place when oxalic acid is titrated by permanganate in the presence of hydrochloric acid, may be prevented by the addition of a manganous salt. This fact led to the idea of effecting the solution of the alkaline earth oxalates in hydrochloric acid and titrating the free oxalic acid with permanganate in the presence of a manganous salt, and so to the study of the conditions under which precipitates of strontium and barium oxalates could be obtained sufficiently insoluble for quantitative purposes, the conditions under which calcium oxalate is insoluble being already known.

The permanganate solution was standardized against freshly recrystallized ammonium oxalate, and on oxalic acid, the standards agreeing.

Calcium Oxalate.

It is well known that calcium may be estimated by treating the precipitated oxalate with sulphuric acid and titrating by permanganate the oxalic acid set free.† In the work described in the present article, the precipitate of calcium oxalate has been dissolved in hydrochloric acid and the oxalic acid titrated by permanganate in the presence of a manganous salt. The process was as follows: The boiling hot solution of calcium chloride was precipitated with ammonium oxalate, allowed to stand 12 hours, and the supernatant liquid decanted on asbestos. The precipitate was washed two or three times by decantation with 50–100^{cm}³ of cold water and brought on the felt. The crucible containing the precipitate was returned to the beaker, 100–200^{cm}³ of water were added, together with 5–10^{cm}³ of strong hydrochloric acid and 0.5–1.0 gm. of manganous chloride, and the oxalic acid was titrated at a temperature of 35°–45°. The results given in Table I are obviously excellent, and show that calcium, taken as the oxalate, may be estimated by potassium permanganate in the presence of hydrochloric acid and a manganous salt.

Extended washing with hot water, however, is to be avoided after the precipitant, ammonium oxalate, has been removed.

* Gooch and Peters, this Journal, vii, 466.

† Mohr, Titrimethode, 6^{te} Aufl., s. 227.

TABLE I.

CaO, taken as CaCl ₂ . gram.	Ammonium oxalate. gram.	Volume at precipitation. cm ³ .	CaO found. gram.	Error. gram.
0·0656	0·3	100	0·0657	+ 0·0001
"	"	100	0·0656	0·0000
"	"	150	0·0658	+ 0·0002
"	"	100	0·0655	- 0·0001
0·0985	0·5	175	0·0981	- 0·0004
0·1313	0·6	150	0·1315	+ 0·0002
"	"	200	0·1315	+ 0·0002

In one experiment, for example, in which the precipitate, on the felt, was washed fourteen times with portions of about 50^{cm}³ each of hot water, each portion bleached from 2-6 drops of approximately one-tenth normal permanganate, making a total loss of 0·0034 gram. of calcium oxide.

Strontium Oxalate.

Souchay and Lenssen* state that strontium oxalate is soluble in 12,000 parts of water. This fact seemed sufficient to warrant the study of the quantitative separation of strontium as the oxalate. In the work which follows strontium oxalate has been precipitated both in alcoholic solution and in water solution, and for convenience these two conditions of precipitation will be discussed separately. All the strontium salts, of established purity, were standardized by precipitation with sulphuric acid in a solution containing at least one-half its volume of alcohol, and with some solutions confirmatory standards were also obtained by evaporation with sulphuric acid.

Precipitation in Alcoholic Solution.—To determine the completeness of the precipitation in alcoholic solution strontium nitrate was precipitated by ammonium oxalate in a solution containing one-third of its volume of alcohol, the mixture was allowed to stand over night, the liquid was filtered off on asbestos, and the precipitate was treated in the capped filtering crucible with sulphuric acid, ignited, and weighed as the sulphate.

The results are given in Table II.

It is plain from the results recorded in this table that the precipitation of even small amounts of the strontium salt from a solution containing one-third of its volume of alcohol is practically complete.

To determine the minimum amount of alcohol necessary for the complete precipitation of the strontium oxalate, experi-

* Ann. der Chem. (Liebig), cii, 35.

TABLE II.

SrO, taken as Sr(NO ₃) ₂ . gm.	Ammonium oxalate. gm.	Volume at precipitation. cm ³ .	Volume of alcohol.	SrO, found as SrSO ₄ . gm.	Difference. gm.
0.2434	0.8	180	$\frac{1}{3}$	0.2440	+ 0.0006
0.2434	0.8	"	"	0.2437	+ 0.0003
0.0022	0.2	100	"	0.0022	0.0000
0.0013	0.2	"	"	0.0014	+ 0.0001
0.0004	0.04	"	"	0.0004	0.0000

ments were made using varying proportions of 85 per cent alcohol with different amounts of ammonium oxalate, and the filtrates from such experiments were tested for strontium by the addition of more alcohol.

The results are given in Table III.

TABLE III.

SrO, present as Sr(NO ₃) ₂ . gm.	Ammonium oxalate. gm.	Volume of liquid. cm ³ .	Proportion of 85% alcohol.	SrO found in filtrate, weighed as SrSO ₄ . gm.
{ 0.1 " " "	0.4	100	$\frac{1}{5}$	0.0000
	"	"	$\frac{1}{10}$	0.0000
	"	"	$\frac{1}{20}$	0.0004
{ 0.1 " " "	0.2	"	$\frac{1}{5}$	0.0000
	"	"	$\frac{1}{10}$	0.0009
	"	"	$\frac{1}{20}$	0.0020
{ 0.1	0.1	"	$\frac{1}{3}$	0.0002

The results in Table III show that when a moderate excess of ammonium oxalate is present, a volume of 85 per cent alcohol, amounting to one-fifth of the whole, is sufficient to complete the precipitation of the strontium as the oxalate.

The conditions under which strontium oxalate is insoluble having been determined, the process for the volumetric estimation of strontium was carried out as follows: The hot solution of a strontium salt was precipitated with ammonium oxalate, 85 per cent alcohol, amounting to from one-fifth to one-third the total volume, was added, the mixture was allowed to stand over night, and the clear liquid was decanted on an asbestos filter. The precipitate was washed with a mixture of equal parts of 85 per cent alcohol and water, transferred to the filter, dried in the filtering crucible over a flame to free it from alcohol, returned to the beaker previously dried, treated with sulphuric acid, or with 5–10^{cm}³ of hydrochloric acid (in the latter case 0.5–1.0 gm. of a manganous salt being added) and the liberated oxalic acid was titrated by permanganate. The results obtained by this method are accurate and are given in Table IV.

TABLE IV.

Volume during titration 150-250^{cm}³.

SrO, taken as Sr(NO ₃) ₂ . gram.	Ammo- nium oxalate. gram.	Volume at preci- tation. cm ³ .	Propor- tion of 85% alcohol.	Acid present during titration.	SrO found. gram.	Error. gram.
0.0974	0.4	100	$\frac{1}{5}$	HCl	0.0973	-0.0001
"	"	"	"	"	0.0983	+0.0009
"	"	"	"	"	0.0975	+0.0001
"	0.8	"	"	"	0.0981	+0.0007
0.1948	0.4	200	"	"	0.1943	-0.0005
"	0.8	"	"	"	0.1942	-0.0006
0.0974	0.4	100	$\frac{1}{3}$	H ₂ SO ₄	0.0970	-0.0004
"	"	"	$\frac{1}{5}$	"	0.0977	+0.0003
"	"	"	"	"	0.0976	+0.0002
0.1948	0.6	150	"	"	0.1938	-0.0010

In the last experiment in which a comparatively large amount of strontium salt was present and the dilution low, there is a slight tendency towards a minus error due probably to the occlusion of some oxalic acid by the strontium sulphate formed. This phenomenon would favor titration at greater dilution when sulphuric acid is used to liberate the oxalic acid from large amounts of strontium oxalate.

Precipitation in Water Solution.—In order to determine the degree of precipitation of strontium salts in water solution, 0.0974 gram. of strontium oxide, taken as the nitrate, was precipitated by ammonium oxalate, the mixture was allowed to stand over night, filtered on asbestos, the precipitate was washed with water containing one-half of its volume of 85 per cent alcohol, treated in the capped crucible with a few drops of sulphuric acid, ignited, and weighed as the sulphate. The result gave 0.0973 gram. of strontium oxide. The precipitation, therefore, of strontium oxalate, in water solution with a sufficient excess of ammonium oxalate present, is practically complete.

To determine the amount of ammonium oxalate necessary for the precipitation of strontium salts in water solution, experiments were made in which strontium oxalate was precipitated in the presence of varying amounts of ammonium oxalate, allowed to stand over night, the clear liquid was decanted on asbestos, and the precipitate was washed two or three times with 10-20^{cm}³ of cold water. The results obtained by the estimation of the oxalic acid by permanganate show that an amount of ammonium oxalate several times larger than that required for the theoretical formation of strontium oxalate is necessary for the separation of the strontium oxalate. The experiments are recorded in Table V.

TABLE V.

SrO, taken as Sr(NO ₃) ₂ . gram.	Ammonium oxalate. gram.	Volume at precipitation. cm ³ .	Acid present during titration. H ₂ SO ₄	SrO found. gram.	Error. gram.
0.0487	0.064	100	H ₂ SO ₄	0.0441	-0.0046
"	0.0768	"	"	0.0465	-0.0022
"	0.16	"	"	0.0488	-0.0001
0.0974	0.128	"	"	0.0939	-0.0025
"	0.16	"	"	0.0959	-0.0015
"	0.32	"	"	0.0975	+0.0001

The solvent action of a large amount of water on a precipitate of strontium oxalate was tested by washing a precipitate equivalent to 0.0974 gram. of the oxide with 150^{cm³} of cold water. The precipitate, when weighed as the sulphate, showed a loss of 0.0033 gram. as the oxide, which amount was subsequently recovered from the filtrate by the addition of ammonium oxalate and alcohol. Plainly excessive washing with water is to be avoided. In the estimation, therefore, of strontium when precipitated as the oxalate in water solution the amount of water used in washing was limited. It was found that 30-40^{cm³} of water judiciously applied was sufficient to wash out the ammonium salt without producing appreciable solvent effect upon the strontium oxalate.

The process of treatment was similar to that used in the precipitations from alcoholic solution, excepting that no alcohol was added to the solution, that the washing was effected with a limited amount of water, and that, there being no alcohol present to affect the titration, the precipitate was not dried before treatment with permanganate. The results are given in Table VI.

TABLE VI.

SrO, taken as Sr(NO ₃) ₂ . gram.	Ammonium oxalate. gram.	Volume at precipitation. cm ³ .	Acid present during titration. H ₂ SO ₄	SrO found. gram.	Error. gram.
0.0974	0.5	100	H ₂ SO ₄	0.0966	-0.0008
"	"	"	"	0.0985	+0.0011
"	"	"	"	0.0977	+0.0003
"	"	"	"	0.0963	-0.0011
"	0.8	"	"	0.0981	+0.0007
"	"	"	"	0.0966	-0.0008
"	1.0	"	"	0.0965	-0.0009
"	2.0	"	"	0.0963	-0.0011
"	"	"	"	0.0970	-0.0004
0.0778	0.5	"	"	0.0792	+0.0014
"	"	"	"	0.0767	-0.0011
"	"	"	"	0.0776	-0.0002
"	"	"	"	0.0776	-0.0002
0.0974	0.8	250	"	0.0973	+0.0001
"	2.0	"	"	0.0975	-0.0001

SrO, taken as SrCl ₂ . gram.	Ammonium oxalate. gram.	Volume at precipitation. cm ³ .	Acid present during titration.	SrO found. gram.	Error. gram.
B					
0·0974	0·8	100	HCl	0·0971	-0·0003
"	"	"	"	0·0980	+0·0006
"	"	"	"	0·0975	+0·0001
"	"	"	"	0·0980	+0·0006
"	"	"	"	0·0973	-0·0001
"	"	"	"	0·0978	+0·0004
C					
0·2425	0·384	125	H ₂ SO ₄	0·2376	-0·0049
0·2436	"	"	"	0·2402	-0·0034
"	0·64	"	"	0·2411	-0·0025
"	0·8	"	"	0·2367	-0·0069
"	2·0	"	"	0·2376	-0·0060
"	"	"	"	0·2402	-0·0034
D					
0·2436	0·8	250	H ₂ SO ₄	0·2443	+0·0007
"	"	"	"	0·2446	+0·0010
"	2·0	"	"	0·2440	+0·0004
"	"	"	"	0·2431	-0·0005
E					
0·2436	0·8	500	H ₂ SO ₄	0·2396	-0·0040
"	2·0	"	"	0·2403	-0·0033
"	2·0	"	"	0·2413	-0·0023
"	4·0	"	"	0·2410	-0·0026
"	8·0	"	"	0·2407	-0·0029
0·4872	2·0	"	"	0·4837	-0·0035
"	4·0	"	"	0·4855	-0·0017
0·5430	5·0	"	"	0·5422	-0·0008
0·4579	10·0	"	"	0·4554	-0·0025
0·7307	5·0	"	HCl	0·7262	-0·0045

In the experiments recorded in section A of Table VI, the strontium oxalate was treated with sulphuric acid and titrated at 80°, the volume being 200–300^{cm}³; while in the experiments given in section B, the precipitate was treated with hydrochloric acid and titrated at 35°–45°, at a volume of 100–200^{cm}³, after the addition of 0·5–1·0 gram. of manganous chloride. The results show that 0·1 gram. of strontium salt, calculated as the oxide, may be estimated as the oxalate with a fair degree of accuracy when precipitated in 100–250^{cm}³ of water by a sufficient excess of ammonium oxalate. In the experiments recorded in section C, in which the amount of strontium salt in 125^{cm}³ of water is increased, a negative error is introduced,

which is not diminished by the presence of a large amount of ammonium oxalate, but when the dilution is increased to 250^{cm³}, as is the case in the experiments given in section D, so that the conditions correspond more nearly to those recorded in sections A and B, the errors fall to a minimum. In the experiments recorded in section E, in which the dilution is increased to 500^{cm³}, an error is introduced which is not prevented by the presence of a large excess of ammonium oxalate and which is independent of the amount of strontium salt used. Eight of the water filtrates and wash waters obtained in the experiments recorded in Table VI were tested for traces of strontium by the addition of alcohol, and in all cases a small amount of strontium was found, amounting in the average to 0.0010 grm. in 100^{cm³} of water.

Barium Oxalate.

Barium oxalate according to Souchay and Lenssen* is soluble in 2,590 parts of cold water, and according to Bergman† is scarcely at all soluble in alcohol. The attempt was made to estimate barium by precipitation with ammonium oxalate in a mixture containing alcohol. It was found that in filtrates from oxalate precipitations in which 0.1–0.2 grm. of barium oxide, taken as the nitrate, had been precipitated in volumes of 100^{cm³} containing 30^{cm³} of absolute alcohol, and allowed to stand over night, treatment with sulphuric acid gave barium sulphate amounting in the average to no more than 0.0001 grm. of barium oxide. The insolubility of barium oxalate under these conditions, therefore, is practically complete.

The process for the estimation of barium was as follows: Ammonium oxalate was added to a solution of a barium salt, containing 30 per cent of its volume of alcohol, the mixture was allowed to stand over night, filtered on asbestos, the precipitate was washed by decantation with 100–200^{cm³} of water containing 30 per cent of its volume of alcohol, and dried over a flame to insure the removal of alcohol. The crucible containing the precipitate was returned to the beaker also previously dried over a flame, 100–200^{cm³} of water, 5–10^{cm³} of strong hydrochloric acid, and 0.5–1.0 grm. of manganous chloride were added, and the solution was titrated at 35°–40° with permanganate. The results of the experiments, given in Table VII, A, show that barium, either as the nitrate or chloride, may be estimated in the manner described with a fair degree of accuracy.

* Ann. der Chem. (Liebig), xc, 102.

† Bergman's Essays, i, 320.

TABLE VII.

BaO, taken as Ba(NO ₃) ₂ . grm.	Ammonium oxalate. grm.	Volume at precipitation. cm ³ .	Acid present during titration.	BaO found. grm.	Error. grm.
0·1165	0·2	100	HCl	0·1177	+ 0·0012
"	"	"	"	0·1170	+ 0·0005
"	"	"	"	0·1164	- 0·0001
"	"	"	"	0·1151	- 0·0014
"	"	"	"	0·1165	0·0000
"	"	"	"	0·1176	+ 0·0011
"	"	"	"	0·1164	- 0·0001
0·2330	0·4	"	"	0·2319	- 0·0011
"	"	"	"	0·2335	+ 0·0005
"	"	"	"	0·2342	+ 0·0012
BaO, taken as BaCl ₂ .					
0·0942	"	"	"	0·0952	+ 0·0010
"	"	"	"	0·0939	- 0·0003
"	"	"	"	0·0941	- 0·0001
0·1884	0·4	"	"	0·1893	+ 0·0009
"	"	"	"	0·1892	+ 0·0008
			B		
0·0942	0·2	200	H ₂ SO ₄	0·0858	- 0·0086
0·1884	0·4	"	"	0·1732	- 0·0152
0·0942	0·2	500	"	0·0857	- 0·0085

In the experiments given in section B of Table VII, the precipitate of barium oxalate was treated with sulphuric acid after the addition of the stated amount of water. The results show a large loss of oxalic acid probably due to the occlusion of some of the oxalic acid by the barium sulphate. This fact must prevent the use of sulphuric acid in an analytical process which depends upon the liberation of oxalic acid from barium oxalate.

Gravimetric Estimation of the Oxalates of Strontium and Barium.

It is well known that calcium may be weighed as the carbonate after a careful ignition of the oxalate, and it would seem probable that strontium might also be weighed as the carbonate. Precipitates of strontium oxalate, on asbestos, were ignited in a capped crucible from 2-8 minutes in the flame of a Bunsen burner and weighed as the carbonate, and in a single case the carbonate thus produced was converted by treatment with sulphuric acid to the sulphate and weighed as such. The results are given in Table VIII, and, while they show slight losses, the results are fairly accurate.

TABLE VIII.

	SrO, taken as Sr(NO ₃) ₂ . gram.	SrO, calculated from SrCO ₃ found. gram.	SrO, calculated SrSO ₄ found. gram.
1	0·1120	0·1113	----
2	0·1120	0·1116	----
3	0·2435	0·2425	0·2437

Precipitates of barium oxalate were also ignited from 5–10 minutes and weighed as the carbonate. The results are given in Table IX, and are fairly accurate.

TABLE IX.

BaO, taken as Ba(NO ₃) ₂ . gram.	BaO, found as BaCO ₃ . gram.	Difference. gram.
0·2912	0·2909	—0·0003
“	0·2901	—0·0011
“	0·2901	—0·0011

The results of this work may be summarized as follows: In the estimation of calcium by titration of the oxalate with permanganate, accurate results may be obtained when hydrochloric acid (with a manganous salt) is used as the solvent. Strontium salts may be precipitated by ammonium oxalate with practical completeness in a solution containing one-fifth its volume of 85 per cent alcohol, and with approximate completeness from water solutions at a dilution not exceeding 250^{cm}³. Furthermore, strontium oxalate may be titrated by permanganate with accuracy when either sulphuric acid or hydrochloric acid (with a manganous salt) is used to liberate the oxalic acid. Barium salts may be precipitated with practical completeness by ammonium oxalate in a solution containing one-third its volume of alcohol (85 per cent) and the barium oxalate thus obtained may be dissolved in hydrochloric acid and titrated by permanganate after the addition of a manganous salt. Strontium and barium oxalates may be converted to the carbonates by ignition and weighed as such.

ART. XXVI.—On *Calaverite*; by S. L. PENFIELD and W. E. FORD.

Introduction.—In 1868 the late Professor F. A. Genth* assigned the name *Calaverite* to a massive telluride of gold, from the Stanislaus Mine, Calaveras County, California. It was shown by his analyses that it contained but little silver (3.0 to 3.5 per cent), thus differing from sylvanite from Transylvania which contains from 11 to 13 per cent. It corresponds, however, like sylvanite, to the general formula $[\text{Au,Ag}]\text{Te}_2$. He described it as having a bronze-yellow color and an uneven to subconchoidal fracture. As far as the difference in chemical composition between sylvanite and calaverite are concerned, it might be questioned whether the latter has a right to be regarded as a distinct species, for in their combinations with tellurium, gold and silver are isomorphous. Calaverite, however, has been supposed to have a crystalline structure different from that of sylvanite, for it has no distinct cleavage, and this property is one of the best means of distinguishing the mineral from sylvanite, which has a perfect cleavage in one direction, parallel to the clino-pinacoid. Krennerite, also, the orthorhombic species of the same general formula, $[\text{Au,Ag}]\text{Te}_2$, has a perfect cleavage, parallel to the base.

Calaverite was later described by Genth† from Boulder, Colorado, two analyses being given, one showing 2.24 and the other 3.03 per cent of silver. In 1895 W. F. Hillebrand‡ described calaverite from Cripple Creek, Colorado, giving three analyses of materials from different mines, containing respectively 3.23, 1.77 and 0.90 per cent of silver. The material for the first analysis given by him was from the Prince Albert Mine. It was well crystallized, and was sent to one of the writers of this paper (Penfield) for examination. The crystals, however, proved to be unusually perplexing, and although considerable time was spent in studying them the investigation did not lead to decisive results. In a brief note accompanying Dr. Hillebrand's article, it was stated that the crystals had certain angles which were nearly like those of sylvanite, and that with the material then at hand it did not seem possible to establish the system of crystallization with certainty. It was suggested, because of the lack of symmetry in the distribution of the faces, that the crystals probably belonged to the triclinic system.

* This Journal (2), xlv, p. 314.

† Am. Phil. Soc., xiv, p. 229, 1874 and xvii, p. 117, 1877.

‡ This Journal (3), I, p. 128.

Since the publication of Dr. Hillebrand's paper it has always been the intention to again take up the study of the crystallization of calaverite, and requests have been made to numerous friends to secure, if possible, material suitable for study. These requests have been generously responded to, and we take special pleasure in here expressing our obligations to Messrs. Lazard Cahn of New York, T. A. Rickard of Denver, and Maynard Bixby of Salt Lake City, for the pains which they have taken to secure the materials needed for the present investigation. In addition to the materials sent us by the gentlemen whose names have just been given, we have also the crystals furnished by Dr. Hillebrand, already referred to. Altogether we have been able to include in our investigation crystals from five different mines in the Cripple Creek region.

The results of the present investigation indicate that calaverite crystallizes in the *Monoclinic System*. The crystals are prismatic or lath-shaped, with their longer axes corresponding to the ortho- or symmetry-axis *b*. The development of the crystals thus corresponds to that commonly observed on epidote. Invariably, as observed by us, the crystals are striated parallel to their longer direction, due to oscillatory combinations of the forms in the ortho-dome zone. The oscillations generally give rise to a rounding of the edges in the striated zone, and often very irregular cross-sections result therefrom, as will be shown. When this prominent zone is studied with the reflection goniometer, there often results an almost unbroken succession of reflections of the signal as a crystal is turned. There is no especially prominent face in the zone which may be easily identified, and relied upon as a starting point in making a series of measurements. Terminal faces, on the other hand, are generally free from striations and are in every way satisfactory for measurement with the reflection goniometer. Uncertain or multiple reflections of the signal, due to vicinal development of the faces or other disturbing causes, were seldom encountered. All of the work of determining the system of crystallization, the axial ratio and the symbols of the forms had to be based upon measurements made from the terminal faces, and these being at times unequally developed, and always quite small, the problem proved to be an unusually difficult one. It may not be out of place to state at this point that in the unequal development of the crystal faces, in the scarcity of zones, and in the complex symbols derived from the measurements, calaverite crystals are unlike any that have ever come to the attention of the present writers. The crystals seem almost to present a contradiction to some of the laws of crystallography.

Determination of the Axial Ratio.—The crystal which

seemed to promise the best results, and which was selected first of all for study, is represented in orthographic projection upon the clino-pinacoid by figure 2, page 229. It was apparent on inspection that certain faces, *m*, *s*, *q*, *o*, and *p*, occurred in pairs, as demanded by monoclinic symmetry, and the monoclinic character was fully substantiated by measurements. Two of the forms, *m* and *p*, to which the symbols (110) and (111) are assigned, agree very closely with corresponding forms on sylvanite, as shown by the following comparison :

		Calaverite.		Sylvanite.
<i>m</i> \wedge <i>m'</i> ,	110 \wedge $\bar{1}10$	=	63° 1'*	62° 56'
<i>p</i> \wedge <i>p</i>	111 \wedge $\bar{1}\bar{1}\bar{1}$	=	93 49	94 30
<i>m</i> \wedge <i>p</i>	110 \wedge 111	=	36 38*	37 3
<i>m'</i> \wedge <i>p</i>	$\bar{1}10$ \wedge 111	=	68 45*	

Taking the measurements marked by asterisks as fundamental, the following axial ratio has been calculated, with which, for comparison, that of sylvanite is also given :

Calaverite, $a : b : c = 1.6313 : 1 : 1.1449$; $\beta = 89^\circ 47\frac{1}{3}'$
 Sylvanite, " " = $1.6339 : 1 : 1.1265$; $\beta = 89^\circ 35'$

As will be shown later, the forms *m* and *p* occur on most of the crystals, and, with the exception perhaps of the form lettered *o*, they are the most prominently developed of the terminal faces. We feel, therefore, that the choice of these as the unit prism *m* (110) and the unit pyramid *p* (111) is the best that can be made, especially as the axial ratio derived from them is so nearly like that of sylvanite. Taken in connection with the similarity in chemical composition between calaverite and sylvanite, it does not seem probable that such close agreement in crystalline characters is wholly a matter of accident.

Thus far the crystallization of calaverite seems simple and satisfactory ; beyond this point, however, the results are almost startling from a crystallographic standpoint, since but few of the many faces observed have simple indices. As no possibility of simplifying the symbols has presented itself to us, it has been decided to give our results in such a form that they may be made use of by others, and we will ask our readers to reserve their judgment of our interpretation of the crystals until the results have all been presented.

Peculiarities of Crystallization: Method of measuring.—Although the crystals are highly modified, a scarcity of zonal relations among the terminal faces is noticeable. The only prominent zone is that of the forms lettered *D*, *p*, *o*, *q* and *s*, figure 2 et seq., also shown in the stereographic projection,

figure 30, page 242. Having in nearly every instance a distorted crystal to work with, showing few zonal relations and no clino-pinacoid, and not being able to make measurements from easily identified forms in the striated zone, it soon became evident that the identification of the small terminal faces with a one-circle goniometer would prove a most laborious undertaking. With a two-circle goniometer, on the other hand, both the measurement of the crystals and the interpretation of the results are very much simplified; in fact, without this instrument it would have been next to impossible to have identified the forms of some of the crystals. The crystals were orientated on the two-circle goniometer with the striated zone (the ortho-axis of the crystals) parallel with the axis of the vertical circle. Having adjusted so that a measurement between two m faces was obtained by turning the horizontal circle, the position half way between the two m 's was taken as the theoretical clino-pinacoid (010), or polar face, while the reading of the vertical circle at this point gave the position of a theoretical ortho-pinacoid (100) in the striated zone. The two readings served as starting points for making all measurements. The clino-pinacoid was observed on but few crystals and the ortho-pinacoid on only one, therefore nearly all of the measurements which will be recorded were made, not from actual faces, but from the theoretical positions of the (100) and (010) forms.

One peculiarity to be borne in mind in studying crystals of the monoclinic system is that the distribution of the faces at opposite extremities of the ortho-axis have a right- and a left-handed relation, as will be indicated by the figures. The two ends cannot be interchanged.

As has been stated already, the faces in the zone parallel to the ortho-axis are striated, and they oscillate with one another to such an extent that most of the crystals have very irregular cross-sections when viewed in the direction of their longer- or ortho-axis. In representing the crystals, orthographic projections upon the clino-pinacoid have been employed, and the figures are intended to show irregularities of contour, as well as variations in the relative size and distribution of the terminal faces as exhibited by the specimens.

In order to shorten and simplify the description of the crystals they will be treated in groups, as far as possible, and the symbols of the forms together with their measured and calculated angles will be condensed in tables. It would consume altogether too much space and be of too little interest to give separate tables of measured and calculated angles for each crystal which has been examined.

Occurrence No. 1. Crystals from the Monument Mine.—The material was presented to us by Mr. Cahn, and consists of

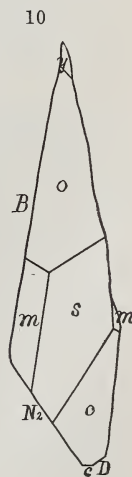
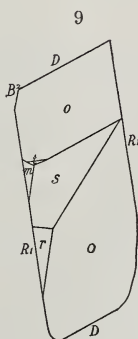
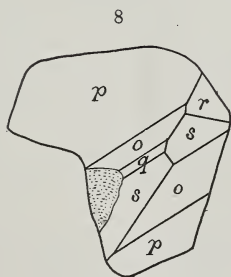
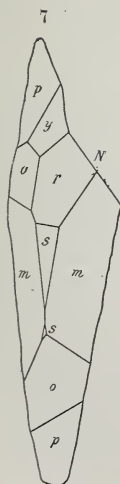
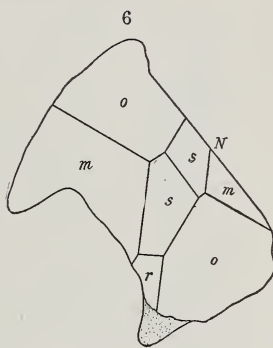
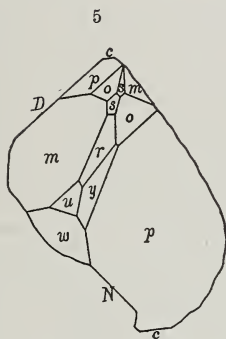
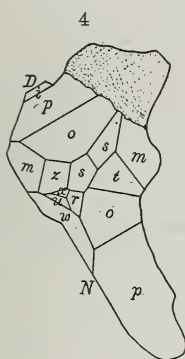
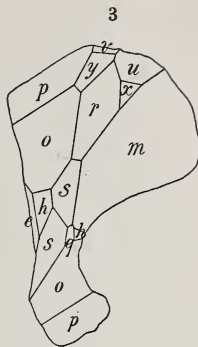
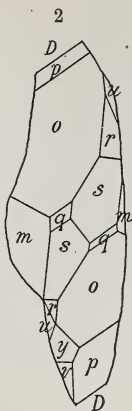
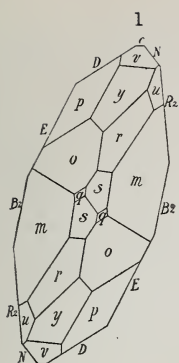

fifteen terminated crystals besides numerous fragments. Some of the fragments, which are portions of lath-shaped crystals without terminal faces, measure over a centimeter in length and breadth. The terminated crystals are quite uniform in size, averaging about 5^{mm} in length by 3^{mm} in thickness. They were detached from the matrix and looked as though they all might have come from one cavity. Nine of them are right-hand terminations, and are represented by figures 2 to 10. Figure 1 gives an ideal representation of the forms observed on the most symmetrically developed crystal, shown by figure 2. The terminal faces occurring on the nine crystals, with their symbols, measured and calculated angles, and the total number of times they were observed, are given in the following table:

	Symbols.	Measured.		Calculated.		Times observed.
		Vertical.	Horizontal.	Vertical.	Horizontal.	
<i>m</i>	110	00° 00'	31° 29'	00° 00'	31° 30½'	14
<i>e</i>	42·44·11	20 21	32 10	20 26	32 1	1, figure 3
<i>t</i>	13·20·4	24 5	23 10	23 38½	23 32½	3
<i>q</i>	11·29·5	33 4	15 46	32 52	15 30½	4
<i>h</i>	21·37·11	36 40	23 19	36 40	23 30½	2, figure 3
<i>o</i>	13·22·10	46 59	28 2	47 30½	28 18	18
<i>p</i>	111	54 44	46 51	54 48	46 54½	12
<i>i</i>	10·7·11	57 13	58 8	57 18	58 29	1, figure 4
<i>y</i>	296	76 21	30 28	76 38	30 54	5
<i>v</i>	2·11·10	81 52	38 15	81 48	38 43½	2
<i>r</i>	10·44·15	114 53	18 27	114 54	18 10½	10
<i>w</i>	111	125 6	46 46	124 55	46 48½	3
<i>u</i>	11·18·10	127 8	30 55	127 32	31 28	5
<i>x</i>	11·20·6	141 59	22 50	142 4	23 5	2
<i>s</i>	11·62·6	142 25	8 3	142 4	7 50	16
<i>z</i>	15·22·1	174 9	22 42	174 34	22 46	1, figure 4

Five of the crystals studied are left-hand terminations, shown by figures 12 to 16. In order to facilitate the identification of the faces figure 11 is introduced, which is a mirror image of figure 1, and represents a possible symmetrical development of the prominent forms. Of the sixteen forms observed on the nine right-hand terminations twelve were observed on the five left-hand ends, and one additional form *n*. The forms, together with their measured and calculated angles, are given in the table which follows.

Of the forms observed on the fourteen terminations studied, *o* is represented by 26 faces, *s* by 23, *m* by 20, *p* by 19 and *r* by 13, the possible number of faces of each kind being 28.

Although the faces in the zone parallel to the ortho-axis were generally so striated that reflections from them could not be

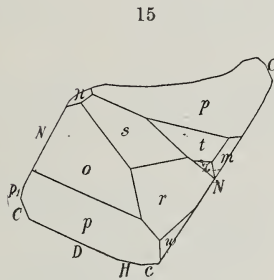
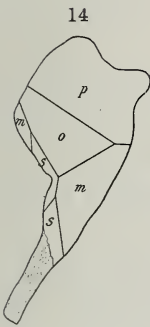
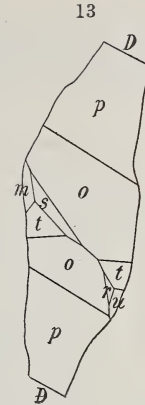
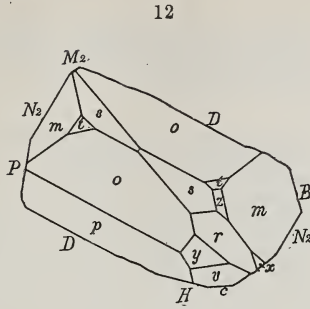
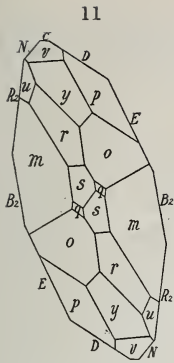

	Symbols.	Measured.		Calculated.		Times Observed.
		Vertical.	Horizontal.	Vertical.	Horizontal.	
<i>m</i>	110	00° 00'	31° 30½'	00° 00'	31° 30½'	6
<i>t</i>	13·20·4	23 33	23 12	23 38½	23 32½	5
<i>o</i>	13·22·10	47 13	28 14	47 30½	28 18	8
<i>n</i>	11·14·10	52 16	38 56	52 12	38 17½	1, figure 15
<i>p</i>	111	54 45	46 56	54 48	46 54½	7
<i>y</i>	296	76 40	30 18	76 38	30 54	1
<i>v</i>	2·11·10	81 48	38 27	81 48	38 43½	1
<i>r</i>	10·22·15	114 14	18 29	114 54	18 10½	3
<i>w</i>	111	125 9	46 44	124 55	46 48½	1
<i>u</i>	11·18·10	127 13	31 6	127 32	31 28	1
<i>x</i>	11·20·6	142 1	23 5	142 4	23 5	2
<i>s</i>	11·62·6	142 3	8 10	142 4	7 50	7
<i>z</i>	15·22·1	174 28	22 38	174 34	22 46	2

relied upon, the zone was carefully studied and a record kept of all especially prominent reflections. The results are summarized in the following table:

	Symbols.	Measured on vertical circle.	Number of observations.	Average.	Calculated.
B ₂	75·0·11	11° 35' to 11° 48'	3	11° 43'	11° 48'
C	501	15 36	1	15 36	15 53½
C ₁	401	19 27 - 19 40	2	19 34	19 35
E ₁	11·0·4	26 49 - 27 56	3	27 16	27 21
D	304	62 8 - 63 8	9	62 26	62 4
H	5·0·11	71 22 - 72 18	7	71 53	71 36
c	001	89 44 - 90 4	8	89 55	89 47½
L	104	99 50	1	99 50	99 45
M ₁	110·0·11	122 24 - 122 49	4	122 38	122 23
M	101	124 27	1	124 27	124 55
M ₂	111·0·10	126 49 - 127 6	3	126 59	127 32
N ₁	111·0·6	141 41 - 142 40	4	142 13	142 4
N	201	143 22 - 144 21	7	143 56	144 28
N ₂	24·0·11	146 20 - 147 14	3	146 42	146 47
P ₁	25·0·4	167 8 - 167 16	3	167 11	167 9
R	901	170 14 - 170 44	2	170 29	171 0
R ₁	111·0·1	172 31 - 172 51	4	172 44	172 37
R ₂	15·0·1	174 10 - 175 45	4	174 55	174 35

Among the crystals from the Monument mine there was one twin which will be described later.

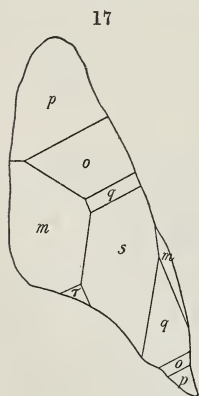

than anticipated. The reflections though not bright were perfectly distinct. The development of the forms is represented by figure 17. The terminal forms with one exception,

Occurrence No. 2.—Among the specimens sent by Mr. Bixby were some detached crystals somewhat resembling those just described, though certainly from a different mine. The suite consisted of a number of fragments and one terminated crystal, the latter measuring about 2^{mm} in greatest diameter and 4^{mm} in length. The crystal faces were not bright, and it was believed at first that it would be useless to attempt to measure the angles, but, realizing the importance of extending our investigation to material from as many sources as possible, the crystal was placed in the goniometer and gave far better reflections than anticipated. The reflections though not bright were perfectly distinct. The development of the forms is represented by figure 17. The terminal forms with one exception,

τ , are the same as those already recorded. In the striated zone a distinct reflexion was obtained from a face corresponding to the ortho-pinacoid $a(100)$, which has been observed only on this crystal.

The measured and calculated angles are as follows :

	Symbols.	Measured.		Calculated.		Times observed.
		Vertical.	Horizontal.	Vertical.	Horizontal.	
m	110	00° 00'	31° 17'	00° 00'	31° 30½'	2
q	11·29·5	33 41	15 10	32 52	15 30½	1
o	13·22·10	46 50	27 45	47 30½	28 18	2
p	111	55 8	46 54	54 48	46 54½	2
s	11̄·62·6	143 15	8 13	142 4	7 50	1
τ	3̄1·38·11	153 16	28 55	153 8	29 14	1
a	100	00 00	90 5	00 00	90 00	2
F	11·0·5	31 41	90 00	32 52	"	1
G	13·0·10	47 3	"	47 30½	"	1
N	201	144 22	"	144 28	"	2
R_1	11̄·0·1	173 10	"	172 37	"	1

Although the discrepancy between the measured and calculated values is considerable in some cases, the agreement is sufficiently close to indicate that the forms are identical with those of the first occurrence. A similar irregularity of contour is also noticeable, as shown by the figure.

Occurrence No. 3. Crystals from the Moon Anchor Mine.—

Our study is confined to two small crystals detached from a gangue specimen sent us by Mr. Rickard. The crystals are lath-shaped, measuring 1·5^{mm} in length and 2 by 0·3^{mm} in cross section. The development of the crystals is represented by figures 18 and 19. The gangue upon which the crystals occur seems to be a decomposed ande-

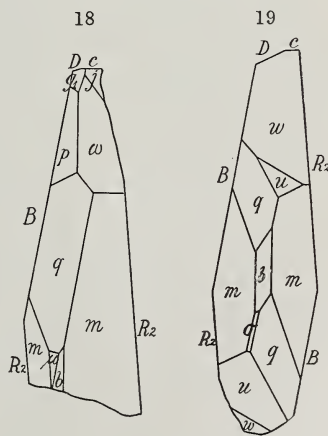

site, the calaverite having been deposited along with quartz and fluorite in a crevice. The forms together with their measured and calculated angles are recorded in the following table:

	Symbols.	Measured.		Calculated.		Times observed.
		Vertical.	Horizontal.	Vertical.	Horizontal.	
<i>b</i>	010	00° 00'	00° 00'	00° 00	00° 00	2
<i>m</i>	110	00 00	31 28	00 00	31 30½	4
μ	17·40·2	9 58	14 22	9 30	14 48½	2
	33·80·4			9 47½	14 24	
<i>q</i>	11·29·5	32 25	15 33	32 52	15 30½	3
<i>p</i>	111	54 33	46 57	54 48	46 54½	1
<i>g</i> ₁	10·15·22	72 6	52 49	71 36	52 38	1
<i>w</i>	111	125 16	46 47	124 55	46 48½	3
<i>u</i>	11·18·10	127 40	31 6	127 32	31 28	2
<i>j</i>	756	128 50	53 30	129 11½	53 31	1
<i>s</i>	11·62·6	144 13	7 55	142 4	7 50	1
	2·10·1			144 28	8 33	
<i>B</i> ₁	17·0·2	9 51	90 00	9 30	90 00	1
<i>B</i>	801			10 5½	"	
<i>D</i>	304	62 8	"	62 4	"	2
<i>c</i>	001	89 51	"	89 47½	"	2
<i>R</i> ₁	11·0·1	172 52	"	172 34	"	1
<i>R</i> ₂	15·0·1	175 1	"	174 35	"	1

On these two crystals, as indicated by the figures, attention may be called to the occurrence of the clino-pinacoid *b* (010), or polar face, and to the prominent developments of *m*, *w* and *q*. The forms *g*₁ and *j* have been observed by us on only the one crystal represented by figure 18. There is some uncertainty concerning σ (2·10·11), figure 19. It is a small face, apparently in the zone *m*, *q*, but it is very near to *s* (11·62·6) of occurrence No. 1, which is in the zone *D*, *p*, *o* and *q*. The dome *B* is probably (801), which is in the same zone as *m* and *q*. In cross-section these crystals have a far more regular contour than those of the occurrences previously cited.

Occurrence No. 4.—The occurrence thus designated is that of a suite of specimens sent by Mr. Bixby with no special designation of the mine from which they came. The specimens resemble very closely those from the Moon Anchor mine. The crystals are lath-shaped, some of them very thin, attached to what appears to be an andesitic gangue. They have been deposited in crevices, and are associated with quartz and fluorite. Many of the crystals are much bent and cracked. Although there was an abundance of calaverite on the specimens only one crystal was found which seemed to offer any possibility of measurement. The end of the crystal when detached from the gauge measured about 1^{mm} in length and only 0·6 by 0·15^{mm} in cross-section. Although so very minute, the reflections from its faces were excellent: in fact this

crystal may be regarded as the best we have examined. Without a two-circle goniometer it would have been almost impossible to have measured more than a few of the angles of such a small crystal. With a two-circle goniometer, on the other hand, the measurements were made without difficulty. Altogether seventeen terminal faces were observed on this crystal, the area of whose cross-section is less than that of a hyphen on this printed page. The crystal, which is the most symmetrical in its development of any we have seen, is represented with ideal symmetry in figure 20. The clinopinacoid *b* (010) is present, and monoclinic symmetry is proved by the occurrence of the forms *m*, *o*, *p*, *f*, and *s* as pairs of faces, making in each case almost identical angles on either side of (010), as indicated by the horizontal circle measurements. A complete list of the angles measured on this crystal is given in the following table:

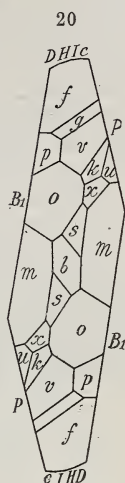

	Symbols.	Measured.		Calculated.	
		Vertical.	Horizontal.	Vertical.	Horizontal.
<i>b</i>	010	00° 00'	00° 00'	00° 00'	00° 00'
<i>m</i>	110	"	31 32	"	31 30½
<i>m</i>	1̄10	"	31 32	"	31 30½
<i>o</i>	13·22·10	47 10	28 12	47 30½	28 18
<i>o</i>	1̄3·22·1̄0	"	28 2	"	28 18
<i>p</i>	111	54 57	47 8	54 48	46 54½
<i>p</i>	1̄11	"	46 41	"	46 54½
<i>f</i>	112	70 21	61 37	70 29	61 40
<i>f</i>	1̄12	"	61 36	"	61 40
<i>g</i>	4·7·10	73 53	52 46	74 7	52 22
<i>v</i>	2·11·10	82 17	38 25	81 48	38 44
<i>k</i>	1̄0·32·21	108 27	31 3	108 18	31 6
<i>u</i>	1̄1·18·10	127 21	30 52	127 32	31 28
<i>u</i>	11·18·1̄0	"	31 00	"	31 28
<i>x</i>	1̄1·20·6	143 52	22 36	142 4	23 5
<i>s</i>	1̄1·62·6	"	7 52	"	7 50
<i>s</i>	11·62·6̄	"	8 00	"	7 50
<i>B</i> ₁	17·0·2	9 26	90 00	9 30	90 00
<i>B</i> ₁	1̄7·0·2̄	9 45	"	"	"
<i>D</i>	3 0 4	63 38	"	62 4	"
<i>H</i>	5·0·11	72 11	"	71 36	"
<i>I</i>	2·0·11	82 25	"	82 25	"
<i>P</i>	1̄1·0·2	165 58	"	165 28	"
<i>P</i>	11·0·2̄	165 26	"	"	"

Most of the terminal faces, b , m , u , p , v , u , x and s , are identical with those observed in previous occurrences. Of the new forms, f , g and k , the two former fall in a zone with D (304) and v ($2 \cdot 11 \cdot 10$), to which zone also t ($13 \cdot 20 \cdot 4$) belongs; compare the stereographic projection, page 242. The forms s and B_1 are somewhat doubtful. They may be σ ($2 \cdot 10 \cdot 1$) and B (801); compare page 234. $11 \cdot 62 \cdot 6$, 110 and $17 \cdot 02$ are in a zone, as are also $2 \cdot 10 \cdot 1$, 110 and 801 .

Occurrence No. 5.—This material includes the crystals from the Prince Albert mine sent to us by Dr. Hillebrand, and previously examined crystallographically by one of us, as already referred to. The crystals average from $\frac{1}{8}$ to 1^{mm} in diameter and 2^{mm} in length. Most of them are twinned according to laws which will be described later, but three which show no indication of twinning are represented by figures 21 to 23.

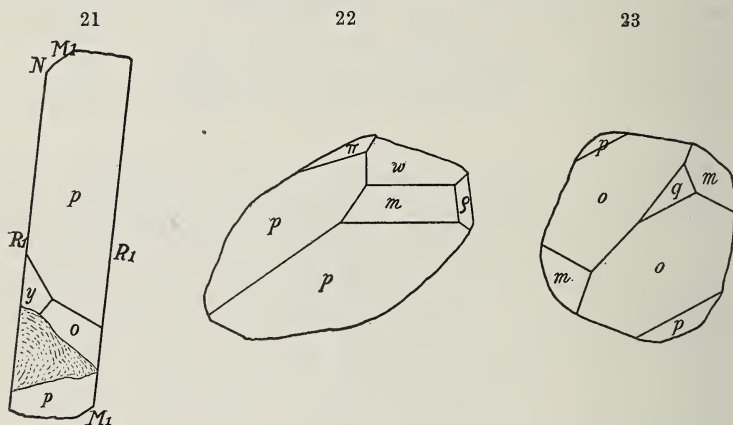
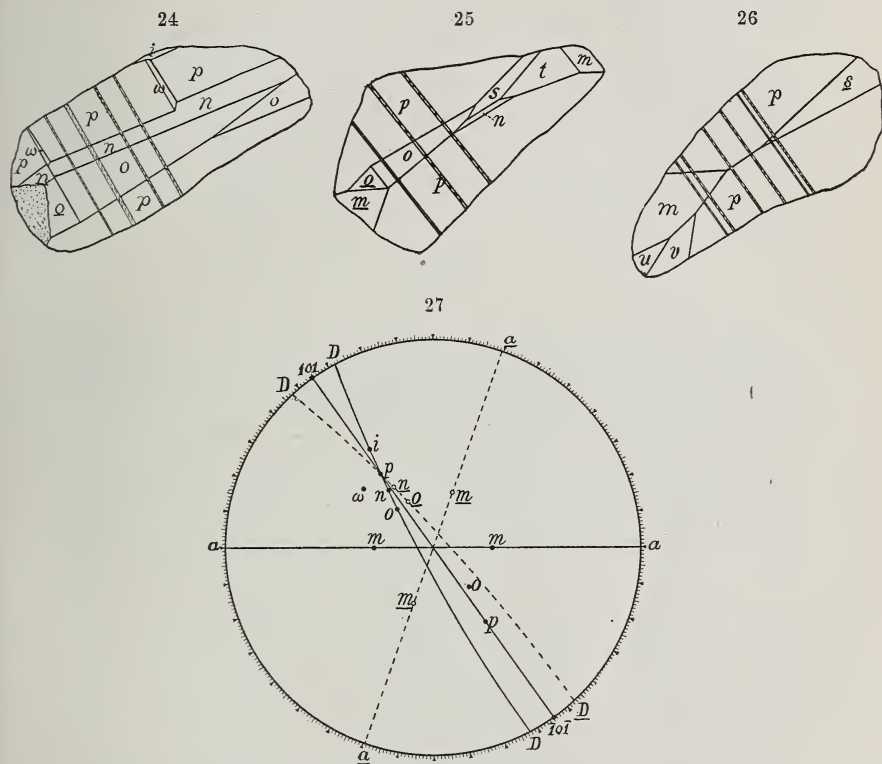

Figure 21 represents a left-hand termination, the others right-hand ends. One, figure 23, is a doubly terminated crystal, showing similar forms at both extremities of the axis of symmetry. The prominent forms are those observed on other occurrences. The new forms π and ρ are each represented by one small face. The symbols of the forms and the measured and calculated angles are as follows :

	Symbols.	Measured.		Calculated.		Times Observed.
		Vertical.	Horizontal.	Vertical.	Horizontal.	
m	110	$00^\circ 00'$		$00^\circ 00'$	$31^\circ 30\frac{1}{2}'$	3
q	$11 \cdot 29 \cdot 5$	$31 \ 59$	$15^\circ 58'$	$32 \ 52$	$15 \ 30\frac{1}{2}$	1
o	$13 \cdot 22 \cdot 10$	$47 \ 3$	$28 \ 1$	$47 \ 30\frac{1}{2}$	$28 \ 18$	3
p	111	$54 \ 50$	$46 \ 50$	$54 \ 48$	$46 \ 54\frac{1}{2}$	6
π	$22 \cdot 18 \cdot 27$	$59 \ 56$	$56 \ 10$	$60 \ 5$	$56 \ 31$	1
y	296	$76 \ 35$	$30 \ 35$	$76 \ 38$	$30 \ 54$	1
ρ	$44 \cdot 21 \cdot 2$	$176 \ 32$	$52 \ 45$	$176 \ 18$	$52 \ 9$	1

Twinning.—Two laws of twinning have been determined which may be stated as follows: 1. The twinning plane is in the ortho-dome zone, at 90° to 101. 2. The twinning plane is the ortho-dome 101. According to both laws the symmetry axis and the positions of the *p* faces are the same for both the normal and twin positions. Penetration twins have also been observed with the symmetry axes, or the striated zones, crossed



at angles of about 90° , but no crystals have been found from which sufficiently accurate measurements could be obtained for determining the exact law of twinning.

The first law of twinning has been observed only on crystals from the Prince Albert mine (Occurrence No. 5). The twinning is partly of the nature of two individuals meeting along the twinning plane and partly of the nature of twin lamellæ, revealed by a series of striations crossing the terminal faces at right angles to the intersection of two *p* faces. Figures 24 to 26 represent three individuals which illustrate this law of twinning, and although the figures do not show the twinning at all distinctly, it is doubtful whether any other kind of illustration

would answer the purpose better. The stereographic projection, figure 27, is better adapted for the purpose. The diameter of the circle, passing through 101, $\bar{1}0\bar{1}$ and the poles lettered *p*, represents the twinning plane, and symmetrically on either side of it are the poles of the two *n* and two *o* faces, making small angles with one another. The poles of the four *m* faces, two in normal and two in twin position, serve to make the orientation clear.

In figure 24 the faces in the upper right-hand portion are in normal position, except for the occasional crossing of twin lamellæ, as indicated by the striations. The faces *n* and *o* below and to the left are in twin position, and make reëtrant angles with the corresponding planes of the normal crystal. The two *p* faces are common to both individuals. The angles $n \wedge n$ and $o \wedge o$, measured over the twinning plane, are as follows:

	Measured.	Calculated.
$n \wedge n$	$3^{\circ} 21'$	$3^{\circ} 14'$
$o \wedge o$	7 2	6 54

The form ω was observed only on this crystal and appears as a very narrow, somewhat tapering face, intersecting *p* and disappearing against a twin lamella. The measured and calculated angles of this crystal are as follows:

	Symbols.	Measured				Calculated			
		Vertical.		Horizontal.		Vertical.		Horizontal.	
<i>p</i>	111	54°	48'	46°	50'	54°	48'	46°	54½'
<i>p</i>	$\bar{1}\bar{1}\bar{1}$	"	"	46	50	"	"	46	54½
<i>n</i>	11·14·10	52	11	38	34	52	12	38	17½
<i>n</i>	of twin	57	10	38	34	57	24	38	17½
<i>o</i>	13·22·10	47	26	28	6	47	30½	28	18
<i>o</i>	of twin	62	0	28	2	62	5	28	18
ω	20·15·12	40	16	47	12	40	26	47	8
<i>i</i>	10·7·11	57	5	58	4	57	18	58	29

On the crystal represented by figure 25 only the small *o* and *m* faces to the left are in twin position, the *o* faces making a reëtrant angle at the twinning plane. A few of the angles of this crystal are as follows:

	Symbols.	Measured				Calculated.			
		Vertical.		Horizontal.		Vertical.		Horizontal.	
<i>p</i>	111	54°	50'	46°	47'	54°	48'	46°	54½'
<i>p</i>	$\bar{1}\bar{1}\bar{1}$	"	"	46	47'	"	"	46	54½
<i>o</i>	13·22·10	47	6	28	5	47	30½	28	18
<i>o</i>	of twin	62	28	28	5	62	5	28	18
<i>m</i>	$\bar{1}10$	00	00	31	34	00	00	31	30½
<i>m</i>	of twin	109	45	31	35	109	35	31	30½

The crystal represented by figure 26 appears for the most part like a normal individual, crossed, however, by twin lamellæ as indicated by the striations. The form lettered *s* seems to be in twin rather than in normal position.

The second law of twinning, where 101 is the twinning plane, has been observed on two crystals, one from the Monument the other from the Prince Albert Mine. These are illustrated by figures 28 and 29, respectively. In the crystal rep-



resented by figure 28 the faces *o*, *m* and part of *s* above are in twin position. The twinning plane separates the two *o* faces, runs through *s*, and disappears in that portion, stippled in the figure, where the crystallization has been interrupted. The *m* faces make a reëntrant angle. The *s* faces in normal and twin position fall almost together, making, according to calculation, an angle of only $0^{\circ} 44'$ with one another. In the crystal under consideration *s* was not a very good face. The measured angles are as follows:

	Symbols.	Measured.		Calculated.	
		Vertical.	Horizontal.	Vertical.	Horizontal.
<i>m</i>	$\bar{1}\bar{1}0$	$00^{\circ} 00'$	$30^{\circ} 52'$	$00^{\circ} 00'$	$31^{\circ} 30\frac{1}{2}'$
<i>m</i>	of twin	70 33	31 37	70 26	31 30 $\frac{1}{2}$
<i>o</i>	$\bar{1}\bar{3}\cdot\bar{2}\bar{2}\cdot\bar{1}\bar{0}$	47 3	28 13	47 30 $\frac{1}{2}$	28 18
<i>o</i>	of twin	117 40	28 13	117 56	28 18
<i>r</i>	$\bar{1}\bar{0}\cdot\bar{4}\bar{4}\cdot\bar{1}\bar{5}$	113 59	18 34	114 54	18 10 $\frac{1}{2}$
<i>s</i>	probably of twin	146 32	8 8	147 20	7 50

In the crystal from the Prince Albert Mine, figure 29, both laws of twinning are combined. The first law is indicated by twin lamellæ crossing the lower portion of the crystal. The faces in the lower left-hand portion of the figure may be regarded as belonging to a single individual in normal position. To the right the two *m* faces meet along the twinning plane, which seems to run for a ways through *s* and then disappears. The salient angle made by the two *m* faces, measured over the

twinning plane, is $35^{\circ} 2'$, calculated $35^{\circ} 4'$. The measured angles are as follows:

	Symbols.	Measured.		Calculated.	
		Vertical.	Horizontal.	Vertical.	Horizontal.
<i>m</i>	110	00° 00'	31° 39'	00 00	31° 30½'
<i>m</i>	of twin	109 41	31 40	109 38	31 30½
<i>t</i>	13·20·4	24 14	23 19	23 38½	23 32½
<i>t</i>	of twin	86 1	23 31	85 57	23 32½
<i>o</i>	13·22·10	47 14	28 11	47 30½	28 18
<i>p</i>	111	54 49	46 49	54 48	46 54½
<i>q</i>	11·29·5	32 9	15 21	32 52	15 30½
<i>s</i>	of twin	147 4	7 52	147 20	7 50

As far as the angles of the crystals are concerned, the second law (twinning plane 101) might be considered as alone sufficient for explaining the two kinds of twinning. Instead of the first law, as stated above, it might then be said that the crystals were twinned about 101, but were united by a *composition face* at right angles to the twinning plane. Since we have in figure 29 a combination of the two kinds of twinning, it has seemed to us simplest to explain it as according to two laws.

Summary.—There have thus far been presented in the tables of angles sufficient data to indicate that there are certain planes which occur on calaverite crystals repeatedly, and with such constancy in their angles that they can not be regarded as in any way accidental. There are no forms more frequent in their occurrence and more prominent in their development than those designated as *m* (110) and *p* (111), unless it is, perhaps, *o* (13·22·10). If it be accepted that *m* (110) and *p* (111) have been well chosen as fundamental forms, then the crystallographic relations between calaverite and sylvanite may be expressed as follows:—Both are closely related not only in chemical composition, but also in their axial ratios and in their axial inclinations β .—Both are alike in crystallizing in the monoclinic system, and in having the dome (101) as twinning plane.—Calaverite differs from sylvanite in having no distinct clino-pinacoid cleavage, and in having, with few exceptions, different forms, most of which must be designated by unusually complex indices.

The symbols assigned by us to the calaverite forms are those which seem to correspond most nearly with the results of our measurements. No one can appreciate more fully than the writers that many of the symbols are so complicated that it is almost impossible to believe that they are true. On the other hand, we fail to find any way of simplifying them which does

not cause discrepancies in the angles greater than the character of the reflections would seem to warrant. It is probable that some of the symbols will need revision and change. The crystals which we have been able to examine are such as might be designated as *good*, though they are not of the very best quality. It should be explained also that all of the crystals in our possession have been studied and all of the results given, not merely a selection of *best values*. If one could have a larger variety of occurrences to select from, it is likely that some exceptionally good crystals might be found from which more exact and reliable measurements could be obtained. A careful study of such crystals would be of great value, for the correctness of the complex symbols indicated by the measurements made by us needs verification. One especially noteworthy feature of the symbols as given by us is that eleven, or some multiple of it, appears in many of them; though the significance of this, if there is any, is not apparent.

It is possible that by adopting another orientation some simplification of the symbols may result. The chances for bringing about much simplification, however, do not seem to be very promising, and any change in orientation must necessarily do away with the apparent similarity in crystallization between calaverite and sylvanite, as indicated by us on page 240.

It was noted in a recent number of *Nature** that Mr. G. F. Herbert Smith had discussed crystals of calaverite before the Mineralogical Society of London, and described them as "trigonal, but pseudo-monoclinic owing to twinning about an axis parallel to the prismatic zone." Upon observing this, we immediately communicated with Mr. Smith, sending him the results of our investigation, and he in reply has kindly sent us a brief statement of his work. He expects soon to publish his results, and we do not feel at liberty to discuss them at this time. It may be stated, however, that he has in the three-circle goniometer recently described by him* an instrument, regarded as especially adapted to the study of such complex crystals as those of calaverite, by means of which he is able to discover zonal relations which ordinarily would escape detection. From the study of these he is led to assign simple indices to the majority of the forms, which necessitates, however, the assumption of trigonal symmetry and a peculiar twinning. As far as the angles and the distribution of the faces are concerned, his crystals, like ours, evidently satisfy the conditions of monoclinic symmetry. We quote the following

* Vol. lxxii, p. 555, 1901.

† *Min. Mag.*, vol. xii, p. 175, 1899.

from his letter:—"Unless, however, the crystals are regarded as triclinic twins it is impossible to obtain simple indices. This, I allow, is the only argument in favor of this view; there are no reëtrant angles. I do not know whether I shall persuade any one to share this view. If the crystals are twinned there must be extraordinarily intimate penetration."

The problem may, perhaps, resolve itself as follows:—Either in the assumption of monoclinic symmetry (which the crystals apparently possess) with complex symbols, or triclinic sym-

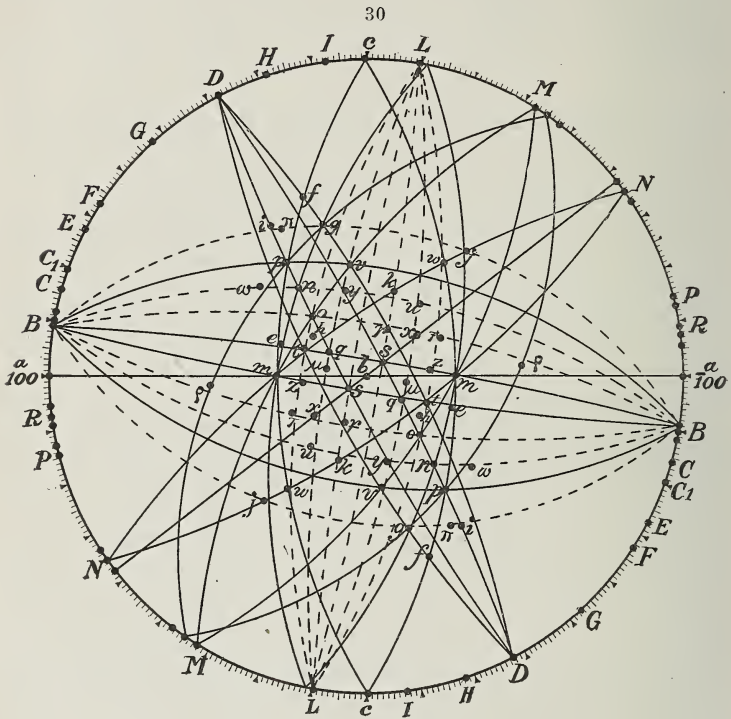

metry (wholly obscured by twinning and resulting in pseudo-monoclinic symmetry) with simple indices.

When the present article was nearly completed we learned from Dr. Palache of Cambridge that he and Professor Moses of New York were also engaged upon the study of calaverite crystals. They both have found the same forms as observed by us, with few exceptions, and also have crystals which are far more complex. It may be expected that the results of their investigation will appear in due time.

It is not claimed that the results as set forth in the present communication furnish an explanation of the crystallization of calaverite. They are presented rather as an accumulation of data which has enabled us to figure and, to a certain extent at least, to describe the crystals, as also to point out close similarities in axial ratios and twinning between calaverite and sylvanite, which, if wholly accidental, are certainly remarkable coincidences. Although our results may not be conclusive nor wholly satisfactory, they are presented in such shape that others may make use of them in formulating any theories they may entertain concerning the crystallization of this remarkable mineral.

For convenient reference all of the forms which have been recorded in the foregoing pages are shown in stereographic projection, figure 30, and are given in the following tables, together with their calculated two-circle angles:

Terminal Forms.

	Symbols.	Vertical.	Horizontal.		Symbols.	Vertical.	Horizontal.
<i>b</i> ,	010	00° 00'	00° 00'	<i>g</i> ₁ ,	10·15·22	71° 36'	52° 38'
<i>m</i> ,	110	00 00	31 30½	<i>g</i> ,	4·7·10	74 7	52 22
<i>μ</i> ,	17·40·2	9 30	14 28½	<i>y</i> ,	296	76 38	30 54
	33·80·4	9 47½	14 24	<i>v</i> ,	2·11·10	81 48	38 43½
<i>e</i> ,	4 4 1?	19 35	33 5	<i>k</i> ,	10̄·32·21	108 18	31 6
	42·44·11	20 26	32 1	<i>r</i> ,	10̄·44·15	114 54	18 10½
<i>t</i> ,	13·20·4	23 38½	23 32½	<i>w</i> ,	1̄11	124 55	46 48½
<i>g</i> ,	11·29·5	32 52	15 30½	<i>u</i> ,	1̄1·18·10	127 32	31 28
<i>h</i> ,	21·37·11	36 40	23 30½	<i>j</i> ,	756	129 11½	53 31
<i>ω</i> ,	20·15·12	40 26	47 8	<i>x</i> ,	1̄1·20·6	142 4	23 5
<i>o</i> ,	13·22·10	47 30½	28 18	<i>s</i> ,	1̄1·62·6	142 4	7 50
<i>n</i> ,	11·14·10	52 12	38 17½	<i>s</i> ₁ ,	2̄·11·1?	144 28	7 47
<i>p</i> ,	111	54 48	46 54½	<i>σ</i> ,	2̄·10·1?	144 28	8 33
<i>i</i> ,	10·7·11	57 18	58 29	<i>τ</i> ,	3̄1·38·11	153 8	29 14
<i>π</i> ,	22·18·27	60 5	56 31	<i>z</i> ,	1̄5·22·1	174 34.	22 46
<i>f</i> ,	112	70 29	61 40	<i>ρ</i> ,	44·21·2	176 18	52 9

Forms in the Zone 100-001.

	Symbols.	Vertical.		Symbols.	Vertical.		Symbols.	Vertical.
<i>a</i> ,	100	00° 00'	<i>G</i> ,	13·0·10	47 30½	<i>N</i> ₁ ,	1̄1·0·6	142° 4'
<i>B</i> ₂ ,	9 0 1	8 59½	<i>D</i> ,	304	62° 4'	<i>N</i> ,	2̄ 0 1	144 28
<i>B</i> ₁ ,	17·0·2	9 30	<i>H</i> ,	5·0·11	71 36	<i>N</i> ₂ ,	2̄4·0·11	146 47
<i>B</i> ,	801	10 5½	<i>I</i> ,	2·0·11	82 25	<i>P</i> ,	1̄1·0·2	165 28
<i>B</i> ₃ ,	75·0·11	11 48	<i>c</i> ,	0 0 1	89 47½	<i>P</i> ₁ ,	2̄5·0·4	167 9
<i>C</i> ,	501	15 53½	<i>L</i> ,	1̄ 0 4	99 45	<i>R</i> ,	3̄01	171 0
<i>C</i> ₁ ,	401	19 35	<i>M</i> ₁ ,	9̄·0·10	122 8	<i>R</i> ₁ ,	1̄1·0·1	172 34
<i>E</i> ,	11·0·4	27 21	<i>M</i> ,	1̄01	124 55	<i>R</i> ₂ ,	1̄5·0·1	174 35
<i>F</i> ,	11·0·5	32 52	<i>M</i> ₂ ,	1̄1·0·10	127 32			

Considerable time has been devoted to the study of the zonal relations of calaverite, with the results shown in the stereographic projection, figure 30, which may be summarized as follows:

1. D (304), i (10·7·11), p (111), n (11·14·10), o (13·22·10), q (11·29·5) and s (11·62·6̄). Symbol of the zone ($\bar{4}$ 1 3). This is the principal zone, and almost the only one which is apparent on simple inspection of the crystals. A possible simpler symbol for s is (2·11· $\bar{1}$), also in this zone, but most of the measurements indicate the more complex symbol.

2. D (304), f (112), g (4·7·10), v (2·11·10) and t ($\bar{1}\bar{3}$ ·20· $\bar{4}$). Symbol of the zone (4 2 $\bar{3}$).

3. c (001), f (112), p (111), m (110) and w (11 $\bar{1}$). Symbol of the zone ($\bar{1}$ 1 0).

4. m (110), k ($\bar{1}\bar{0}$ ·32·21), w ($\bar{1}$ 11), j ($\bar{7}$ 56), and N ($\bar{2}$ 01). Symbol of the zone (1 $\bar{1}$ 2).

5. M ($\bar{1}$ 01), g (4·7·10), p (111) and ρ (44·21· $\bar{2}$). Symbol of the zone (1 $\bar{2}$ 1).

6. m (110), n (11·14·10) and g (4·7·10). Symbol of the zone (10· $\bar{1}\bar{0}$ ·3).

7. m (110), o (13·22·10), v (2·11·10) and M_1 ($\bar{9}$ ·0·10). Symbol of the zone (10· $\bar{1}\bar{0}$ ·9).

8. B (801), q (11·29·5), σ (2·10· $\bar{1}$)? and m ($\bar{1}$ 10). Symbol of the zone (11 $\bar{8}$).

9. B_1 (17·0·2), s (11·62·6̄) and m ($\bar{1}$ 10). Symbol of the zone (2·2·17̄).

10. B_2 (901), p (111) and v (2·11·10). Symbol of the zone (18 $\bar{9}$).

11. b (010), s ($\bar{1}\bar{1}$ ·62·6), x ($\bar{1}\bar{1}$ ·20·6) and N_1 ($\bar{1}\bar{1}$ ·0·6). This is the only case where two pyramidal forms have been observed in a zone between b and a form in the striated zone. Furthermore it is exceptional to find forms in the striated zone having the same vertical circle angles as the pyramids.

In addition to the foregoing there are a number of very close approximations to zones, some of which are indicated by dashed great circles in figure 30. These are drawn from (901) and ($\bar{1}$ ·0·4), and although probable zonal relations seem to be indicated by the projection, the symbols assigned to the forms do not quite satisfy the zonal equations, and possible changes, indicating greater simplicity of the symbols, do not suggest themselves.

Chemical relations of Sylvaniaite and Calaverite.—Both minerals conform to the general formula $[\text{Au,Ag}]\text{Te}_2$, silver being regarded as isomorphous with gold. In sylvaniaite the proportion of gold to silver is near 1:1, so that the formula may be written AuAgTe_2 . The percentage of silver

demanded by the formula is 13.4, whereas the published analyses show from 11.50 to 13.86 per cent. An analysis of sylvanite from Cripple Creek by Palache* yielded 12.49 per cent of silver and a ratio of $Au : Ag = 1 : 0.87$. As most analyses of sylvanite indicate less than 12 per cent of silver, their agreement with the formula $AuAgTe_4$ is only approximate. Calaverite, on the other hand, is a nearly pure gold telluride, conforming closely to the formula $AuTe_2$, though always containing some silver, and at times, as indicated by the analyses, as high as 3.5 per cent. Although chemically there is not a very great difference between calaverite containing 3.5 per cent of silver and sylvanite containing 11.5 per cent, still there is evidently a tendency for sylvanite to conform closely to the formula $AuAgTe_4$ and calaverite to the formula $AuTe_2$. Thus from a chemical standpoint alone calaverite may well be regarded as a distinct mineral species. The relation between the two minerals is analogous to that existing between calcite and dolomite, and as the latter are closely related crystallographically, so calaverite and sylvanite are closely related as indicated by their similarity in axial ratios and twinning.

In order to distinguish between sylvanite and calaverite, the following method of testing, which has been applied to all of the occurrences examined by us, may be recommended: The powdered mineral when boiled in a test-tube with concentrated nitric acid is quickly oxidized, the silver and tellurium going into solution, gold being left. The clear solution, decanted into another test tube, diluted, and tested with hydrochloric acid, gives a precipitate of silver chloride, which is considerable if the mineral is sylvanite, but is slight, or amounts perhaps only to a turbidity, if the mineral is calaverite. After washing the gold by decantation it may be dissolved in a few drops of aqua-regia, indicating a complete separation of gold and silver.

Specific gravity determinations and quantitative estimations of gold and silver have been made on specimens from the Monument Mine and from the unknown Cripple Creek Mine designated as Occurrence No. 2. Of material from the first source a single fragment weighing 0.7729 grams was employed, while from the second source a number of fragments weighing 1.2532 grams were available. The specific gravity determinations were taken with much care on a chemical balance. The results by Penfield are as follows:

* This Journal (4), x, p. 422, 1900.

Sp. Gr. . . .	Monument Mine.		Occurrence No. 2.		Theory.
		Ratio		Ratio	AuTe ₂
Au	40.99	.209	42.77	.217	44.03
Ag	1.74	.016	0.40	.004	-----
Te	[57.25]	.458	[56.75]	.455	55.97
Gangue	0.02		0.08		-----
	<hr/>		<hr/>		100.00
	100.00		100.00		

The ratio of Au+Ag : Te in both analyses is 0.98 : 2.00, or very nearly 1 : 2. The second occurrence approaches very near to a simple gold telluride, the per cent of silver, 0.40, being the smallest thus far recorded in any published analysis of calaverite. The specific gravity determinations are a few tenths higher than generally given; from the nature of the material, however, and the care exercised in taking them they must be very exact. Of the other occurrences examined crystallographically by us, No. 5, from the Prince Albert Mine, contains 3.23 per cent of silver, as determined by Hillebrand, and the others, occurrences 3 and 4, are probably about like the material from the Monument Mine, judging from qualitative tests.

In all of his publications on calaverite Genth describes the mineral as having a bronze-yellow color. This seems to us misleading, for, although the crystals have at times a yellowish cast, the brightest and best of them are silver-white. Some of the dull crystals examined by us have a gray color, very like that of tarnished silver.

It is interesting to note the production of gold from the Cripple Creek region, as communicated to us by Mr. T. A. Rickard of Denver. During 1900 the production amounted to 877,972 ounces, valued at \$18,147,681, and it is probable that the most of this vast amount was derived from calaverite. It was practically all derived from telluride ores, as very little free gold is found in the district, and that only in the uppermost portions of the veins, near the surface.

Sheffield Laboratory of Mineralogy and Petrography,
Yale University, New Haven, July, 1901.

SCIENTIFIC INTELLIGENCE.

1. *On Temporary Set*; by C. BARUS.—Following the suggestions of my last paper* I have since been able to map out the occurrence of what I shall call temporary set, distinguished from permanent set inasmuch as the former may be shaken out of a metal by molecular agitation (without heat, as for instance by magnetization of iron). The latter cannot, of course, be shaken out of the metal. Temporary set ($d\theta$) is instantaneously imparted; it begins with the zero of twist (θ), increasing at an initial rate $d\theta/\theta = .004$, the rate gradually diminishing to zero when the (elastic) obliquity of the external fibre of the twisted wire exceeds .002 radians, after this temporary set becomes unstable, passing into permanent set. The maximum amount of temporary set may be estimated as .0015 of the maximum twist within the elastic limits. Its variation depends not on the impressed strain but on the *antecedent* strain, i. e., the strain between two successive molecular agitations and which may lie on both sides of zero.

2. *Some new rock-types*.—KENYTE. This name has been applied by J. W. Gregory to "liparitic representatives of an olivine-bearing nepheline syenite, consisting of anorthoclase phenocrysts with or without some augite and olivine phenocrysts and a glassy or hyalopilitic groundmass which varies in color from grayish green to a deep sepia-brown. Aegyrine, if present, occurs in small granules; ænigmatite and quartz are absent." The rocks occur as surface lava flows on Mount Kenya in East Africa. They are supposed to be closely related to pantellarites but no analyses are given of them, and as the glassy base is stated to gelatinize with acid and to contain abundant soda, it is difficult to see why they are not glassy phonolites especially as they are held to be surface representatives of the nephelite syenite of the central core.—*Q. J. Geol. Soc.*, lvi, p. 211, 1900.

KEDABEKITE. E. von Federov has given this name to a rock occurring in dike form in the vicinity of the Kedabek mines in the Government Elisabethpol, Transcaucasia. It is very fine granular, of a dark gray with a tone of green. It consists of basic plagioclase, a lime-iron garnet ("aplome") and a strongly pleochroic pyroxene called *violaitite* (conf. p. 86 of this volume). The type is held to be remarkable in that it unites such different kinds as augite-garnet rock and diabase. The occurrence is in close relation with an augite-garnet rock and is held to be a local facies of a neighboring diabase. The analysis by A. Kupffer gave:

	SiO ₂	Al ₂ O ₃	Fe ₂ O ₃	FeO	MnO	CaO	MgO	Na ₂ O	K ₂ O	Ign.
1	44.64	18.54	6.63	4.65	.09	22.17	2.52	.80	.05	.18=100.27
2	44.11	19.38	5.17	5.44	—	21.98	2.90	.50	.13	.26=99.87

The type is mentioned as also occurring in the mining district of Bogoslowk.—*Separate*; conf. also *Annuaire geol. et min. de la Russie*, iv, Liv. vi, p. 137.

L. V. P.

* This Journal, xi, 1901, p. 97.

OBITUARY.

JOSEPH LECONTE, Professor of Geology and Natural History in the University of California, died on the sixth day of July in the 88th year of his age. His death occurred in the Yosemite Valley, California.

Professor LeConte was a noble example of the type of man, now rare, whose distinction and influence are due to breadth of knowledge in all fields of science and clearness of perception and exposition rather than to that exclusive mastery of the minute details of some one branch of science so essential to the expert specialist.

His originality of thought and powers of research are well expressed in the series of papers finally published in 1880 under the title "Light, an exposition of monocular and binocular vision." In this work the dominant characteristics of his mind are exhibited in the combination of a deep and thorough comprehension of the laws of the visible and measurable phenomena of optics, with a keen appreciation of the subtle and invisible workings of the sensitive eye and perceiving mind by which physical vibrations of light are transmuted into conscious sight. Psychology, in his thought, was intimately associated with physiology and physics.

His "Elements of Geology" (1st edition, 1878) has been used by a generation of students and is distinguished for the clearness of its exposition of the principal facts and laws of the science of geology. The philosophical problem connected with the adaptation of evolution to social life, education and religion deeply interested him: and his books "Religion and Science" (1873) and "Evolution and its relations to religious thought" (1887) opened the truths of modern science to many minds that would have long remained in ignorance except for the keen human sympathy and teaching capacity which were prominent traits of his character. He was a man of charming personality, beloved as well as admired by all who met him.

Of Huguenot ancestry, he was born in Georgia, Feb. 26, 1823. He was educated as a physician, though the greater part of his life was spent as a teacher. He studied with Agassiz at Harvard, taking the degree of B.S. in geology and zoology in 1851. He held several professorships in Georgia and South Carolina colleges before the year 1869, when he was appointed Professor of Geology and Natural History in the new University of California, the position he occupied to the end of his life.

He published numerous papers and books on scientific, philosophical and educational subjects. The degree of LL.D. was conferred by the University of Georgia in 1879. He was a member of the National Academy of Sciences, the American Philosophical Society, the American Academy, the New York Academy, the Geological Society of America, the American Association and other scientific societies. He was acting president of the International Congress of Geologists at its meeting in Washington in 1891.

AMERICAN JOURNAL OF SCIENCE

[FOURTH SERIES.]

ART. XXVII.—*On Galvanometers of High Sensibility*; by
C. E. MENDENHALL and C. W. WAIDNER.

AFTER considerable experience with sensitive galvanometers we have been led to the design and construction of an instrument which, while it is not more sensitive than the best hitherto made, still possesses, we think, advantages as regards convenience and ease of manipulation which make this short account worth while. We also give the results of some experiments with minute magnets which have a bearing upon the general subject of sensitive galvanometry.

The galvanometer is of the ordinary four-coil Thomson type, the materials used being brass and glass, with insulating fiber supports for the coils. The dimensions are in general smaller than is customary, as can be seen from fig. 1, which shows a simplified elevation (details omitted), and which is drawn to scale, so that from the dimensions given a general idea of the proportions of the instrument can be obtained. It should be said that the tube for the quartz fiber is supported from the base independently of the outer cylindrical glass case, but the supporting pillars are omitted from the drawing for the sake of simplicity. Figure 2 shows a plan of the working arrangement of galvanometer, control magnet support, etc., while fig. 3 is a photograph of the instrument mounted for use, showing again the adjustments for control magnets, and the method of viewing the needle-system as it hangs in position.

The two pairs of coils are supported on two sliding carriages (suggested by the instrument of Mr. Abbot's design at the Smithsonian Astrophysical Observatory), but these can be given to-and-fro rectilinear motion by screws from outside the case. The coils have adjustments about vertical and horizontal axes, and vertical and horizontal sliding adjustments, so that they can be centered and placed parallel and vertical.

The glass tube carrying the quartz fiber passes through the top of the instrument nearly down to the top of the coils, and

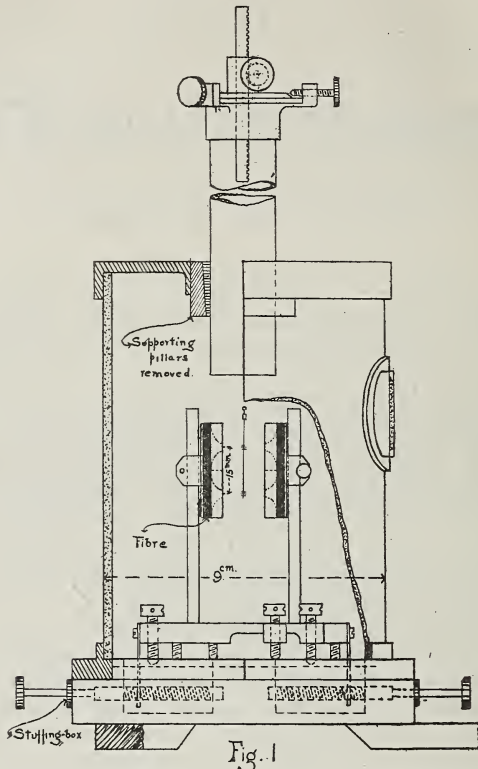

carries at its upper end a rack and pinion motion for raising and lowering the fiber and system. By having the coil sup-

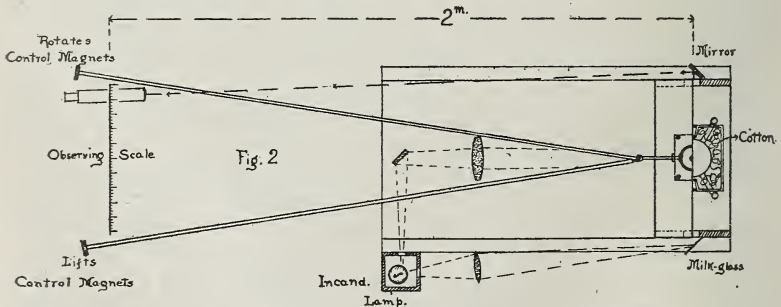

ports slender and out of the way, and the outer case of glass, the space between the coils is well illuminated and easily visible.

The movable coils furnish a quick means of varying the sensibility; and besides, they render the insertion of light and

delicate systems a simple matter. The length of the quartz fiber is so chosen that the entire system can be drawn up into the glass tube; while in this position the tube can be placed in the galvanometer without danger to the fiber or system.

Fig. 3

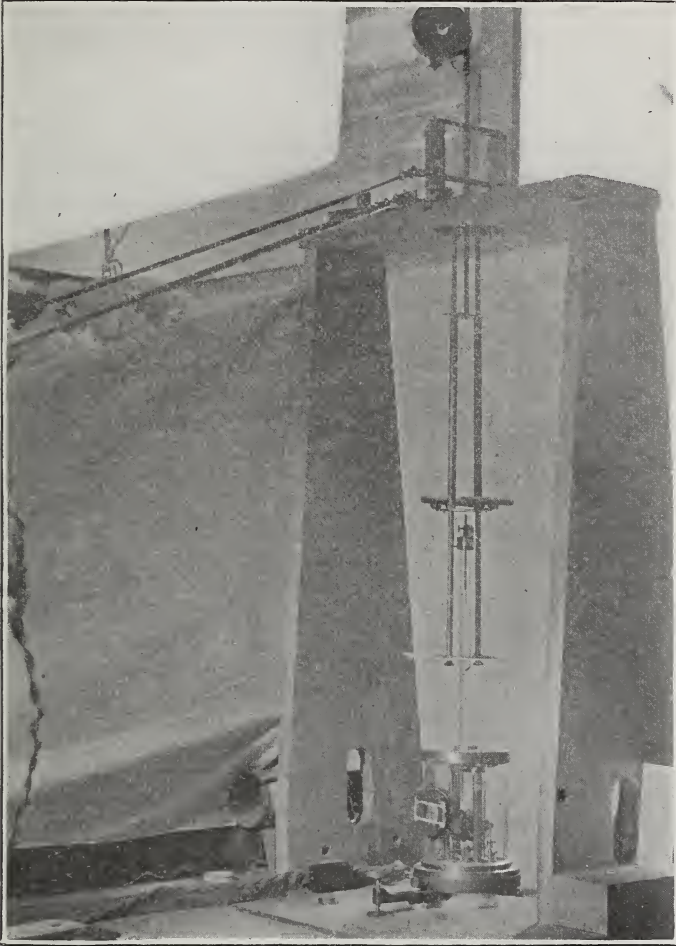

The coils being now pulled apart, the system can be lowered into place, after which the coils can be approached as carefully as is desired. The easy visibility of the system is another important consideration; in particular we have found the arrangement of telescope, mirror and milk-glass screen, as shown in fig. 2 and fig. 3, extremely convenient, as enabling the operator at the scale to know the position of the system independent of the spot of light. The telescope is adjusted so

that the field of view includes the space between the coils, and shows the needle-system clearly defined against the illuminated milk-glass; when the system hangs in the desired position parallel to the coil-faces, the magnets appear end-on, and they are so thin that a very slight departure from this end-on position can be detected. In fact, "finding the spot of light" becomes easy; it can be adjusted to within a few centimeters of its desired position on the scale by adjusting the control magnets until the system-magnets appear end-on, after which the careful adjustment of zero can proceed as usual. The dimensions of the coils being small, very light systems can be used, the control field can be made very nearly equal at the upper and lower coils, and magnetic shielding can be more easily applied. Construction is simplified by the circular form of the case, permitting the extensive use of lathe work.

We would suggest the change of the top of the fiber tube from its present form to that given in fig. 1; the centering screws there shown would allow considerable horizontal adjustment of the fiber, and would clamp it in any desired position. A larger but shorter fiber tube—say 2^{cm} internal diameter, a heavier base, and a method of clamping the outer case above the base, so as to permit free access to the interior, would also be better.

In connection with this instrument we have used a support for control magnets shown in plan in fig. 2, and in perspective in fig. 3; this permits an independent rotation and vertical motion of the symmetrical pair of control magnets, by the observer at the scale, using the long shafts shown in fig. 2. Independent changes in direction and magnitude of the control vector are thus possible.* In our apparatus, one turn of the observer's handle rotates the control magnets through 20°, and this is sufficiently delicate for most circumstances. It is convenient to have the magnetic force due to the control magnets nearly the same at the upper and lower coils, because the behavior of the needle can then be more easily predicted; with our control magnets 35^{cm} above the coils, there is a difference of about 15 per cent, which is ordinarily not enough to confuse matters. For example, if (fig. 4) AO represents in magnitude and direction the earth's magnetic force, AB the direction in which it is desired to have the resultant field, then for a given height of the control magnets there are two positions of the magnets, OC and OD, which give a resultant in the desired direction; one, OC, giving a long period of vibration, the other a short period. These two periods will be obtained provided the force OC due to the control magnets is greater than

*See Waidner, chap. on galvanometers, Ames & Bliss, Laboratory Manual; also, Rogers, in Nichols, "The Galvanometer."

OP and less than OA, and one of the periods increases and the other diminishes as OC approaches AO in magnitude.

Very light systems are of course extremely sensitive to air currents, such as will be produced by very slight inequalities in temperature; it is therefore important that the entire galvanometer be protected somewhat as indicated in fig. 2. The coil faces are covered with gold-leaf—and static charges of electricity upon them have given little or no trouble; but magnetic impurity in the material of the coils is very troublesome, and necessitates a free space of at least a millimeter between the coil faces (see Nichols, "The Galvanometer"). White silk insulation is somewhat better than green, though still very bad; and a part

Fig. 4

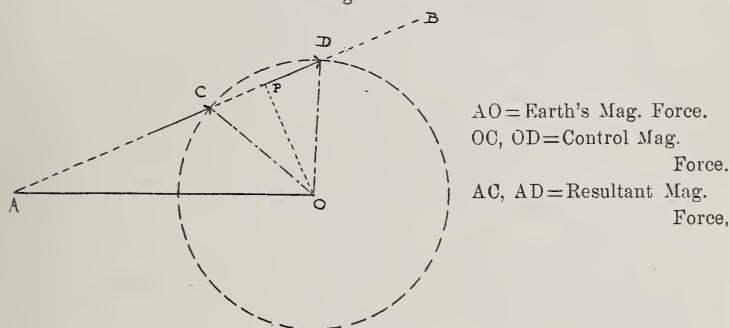

of the difficulty is with the copper itself. The trouble seems to be in part due to a permanent magnetization of the coils, producing sometimes a rather complicated distribution of poles over the coil faces, which can be largely removed by a careful demagnetization of the coils; and in part to the poles induced by the approach of the magnets of the needle system itself—which can only be helped by using purer material.

In winding the coils the ends of all the sections were brought out, and small soldered junctions made on the back of the coil; hence six sizes of wire, viz.—40, 38, 36, 34, 32, 30, could be used without danger of wasting space in junctions. But the gain is probably hardly worth the trouble.

In making very light systems it is convenient to begin by fastening the magnets in the proper relative position, to a piece of plate glass with a solution of sugar or flour paste; after the glass staff and mirror have been fastened on, the system can be loosened with a drop of water. One of our best systems developed after use a second position of equilibrium, which it would assume if given a large deflection; it seemed to be due most probably to a change in strength of the magnets caused by the inductive action of the field, rather than to torsion of the staff of the system—as before suggested.*

* *Astrophys. Journal*, Jan., 1901, p. 47.

Changes of zero, and changes in sensibility.—In general both the zero and the sensibility of a galvanometer will be affected by the changes constantly going on in the direction and magnitude of the earth's horizontal force, and it becomes of interest to know whether there is any position of the galvanometer with respect to the magnetic meridian which will give minimum values for these disturbances. An examination of the magnetic records of the Naval Observatory shows that rather quick changes of H to the amount of nearly 1 per cent may be expected rarely, and to the amount of $\frac{1}{8}$ per cent frequently, while the declination sometimes changes rapidly by $19'$ and frequently by $3'$. A consideration of the vector diagram previously given, involving the earth's horizontal force H , the force due to the control magnet M , and the resultant force R , supposing the above changes to take place in the direction and magnitude of H , and assuming various directions for R , shows that there is no position of the galvanometer for which the resulting changes of zero or sensibility are markedly small. For null methods, however, in which changes of sensibility are of less moment than changes of zero, it would be somewhat advantageous to have the plane of the coils parallel to the magnetic meridian. It is interesting to note the magnitude of the changes produced by the above mentioned changes in H and the declination in the case of two identical systems, both arranged to have a complete period of 10^s in the galvanometer, but one having a period of 1^s in the earth's field, while the other is astaticised to a 4^s period. In the first case the resultant field in the galvanometer would equal $\frac{H}{100}$, in the second case $\frac{H}{6.25}$; and we would have, if the plane of coils is perpendicular to magnetic meridian:—

(a) non-astatic,		
change of zero due to $19'$ change in declination,	=	0°
“ “ “ “ “ “ “ “ H of 1%	=	90°
change of sensibility due to $19'$ change in declination	=	55%
“ “ “ “ “ “ “ “ H of 1%	=	50%
(b) astatic		
change of zero due to $19'$ change in declination	=	0°
“ “ “ “ “ “ “ “ H of 1%	=	$3^\circ 40'$
change of sensibility due to $19'$ change in declination	=	3.5%
“ “ “ “ “ “ “ “ H of 1%	=	$\frac{1}{3}\%$

With the astatic system, but for the smaller changes in H and declination of $\frac{1}{8}$ per cent and $3'$, the change in zero would be less than $30'$ (or 18^m at 1^m distance), and the change of sensibility about 0.6 per cent. This emphasizes the great importance of careful astaticising unless magnetic shielding is available.

Galvanometer Magnets.

The problem usually at hand in the construction of highly sensitive galvanometer systems is to construct a system which shall have the greatest attainable sensibility for a given period of vibration, as it is a great advantage to have a short working period, especially where magnetic disturbances cause constant variations in the zero. If we let

- m_u = magnetic moment of the upper group of magnets,
 m_l = magnetic moment of the lower group of magnets,
 $M = m_u + m_l$
 K = moment of inertia of the system (including also the non-magnetic material),
 H = strength of the resultant controlling field,
 T = time of a complete vibration (undamped),

then we have the following relations

$$T^2 = \frac{4\pi^2 K}{(m_u - m_l) H}$$

But the deflection for a given current and set of coils.

$$d \propto \frac{(m_u + m_l)}{H(m_u - m_l)}$$

or, substituting,

$$d \propto \frac{(m_u + m_l) T^2}{4\pi^2 K}$$

And for a given period this may be written

$$d \propto \frac{M}{K}$$

Consequently the greatest sensibility is attained by building up the system of such magnets that the relation $\frac{M}{K}$ shall be a maximum. It was with this object in view of determining the best dimensions of magnets, quality of steel, the mutual action of magnets on one another when placed near together as they are in galvanometer systems, the effect of boiling, and of mechanical jars, the magnetic moments and inductions attained in these short magnets, etc., that the experiments, recorded in the following tables, were made.

The magnetic moments of these small magnets were studied by mounting a number of them, as nearly alike as possible and whose dimensions had been carefully measured, on small brass discs whose moments of inertia would be accurately computed and were large in comparison with the moment of inertia of the magnets, which entered as a slight correction term. The

magnets were then magnetized in the uniform field of a small electromagnet and vibrated in an exhausted receiver placed at a point where the horizontal intensity of the earth's field had previously been determined. The slight controlling moment of the silk suspension was determined from the time of oscillation of the brass disc without any magnets on it, and allowed for in all the experiments. The results of these experiments are given in the following tables. These magnets were mounted on the face of the disc, side by side, so that they occupied the same relative positions that they would in a galvanometer system.

Designation of Magnet.	Quality of Steel.	Length mm.	Width mm.	Thickness mm.	Volume per Magnet ccn.	Weight per Magnet grms.	Magnetizing Field: C. G. S. Lines.	Magnetic Moment per Magnet.	I Av'ge Intens. of Magnetization.
H ₁	Fine Watch Spring	5.30	0.170	0.061	0.000055	0.00043	3400	0.02580	469
H ₂	"	4.15	0.172	0.060	0.000043	0.000337	"	0.0184	422
H ₃	"	3.16	0.174	0.059	0.000032	0.000251	"	0.0122	382
H ₄	"	1.95	0.175	0.058	0.0000197	0.000155	"	0.00485	246
H ₅	"	1.24	0.175	0.059	0.0000128	0.000100	"	0.00215	168
H ₆	"	1.02	0.173	0.059	0.0000103	0.000081	"	0.00143	139
H ₇	"	0.650	0.170	0.061	0.0000067	0.000053	"	0.000542	81
G ₁	"	3.00	0.197	0.050	0.0000295	0.000232	"	0.0110	372
G ₂	"	1.81	0.197	0.050	0.0000178	0.000140	"	0.00405	228
G ₃	"	0.98	0.210	0.050	0.0000103	0.000081	"	0.00130	127
I ₁	J. and C. Spec. Mag. Steel.	1.12	0.252	0.050	0.0000141	0.000111	"	0.00252	179
I ₂	"	1.15	0.161	0.052	0.0000096	0.000076	"	0.00193	201
B ₁	"	4.12	0.89	0.120	0.00044	0.00345	2200	0.1251	284
"	"						5200	0.1248	283
B ₂	"	1.53	0.79	0.126	0.000152	0.00119	800	0.0102	67
"	"						1300	0.0107	70.5
"	"						3400	0.0107	70.5
B ₃	"	1.09	0.74	0.125	0.000101	0.00079	"	0.0052	51
A ₁	Watch Spring	3.35	0.52	0.115	0.000200	0.00157	3400	0.0407	202
A ₂	"	2.29	0.51	0.115	0.000135	0.00105	"	0.0198	144
A ₃	"	1.67	0.52	0.115	0.000100	0.00078	"	0.0100	99
A ₄	"	0.80	0.50	0.115	0.000046	0.000361	"	0.0031	67
A ₅	"	1.53	0.254	0.114	0.000044	0.000345	"	0.0049	111
C ₁	Boker's Music Wire	3.13	D=	0.22	0.000119	0.00094	"	0.0211	177
C ₂	"	1.14	D=	0.22	0.000043	0.00034	"	0.0024	55
J ₁	Extra fine Steel	2.20	D=	0.078	0.0000105	0.000082	"	0.00284	270
J ₂	"	1.21	D=	0.069	0.0000045	0.000035	"	0.00076	168

Saturation of Magnets.—The experiments with magnet B_1 (see preceding table), magnetized in fields of 2200 and 5200 lines, and with magnet B_2 , magnetized in fields varying from 800 to 3400 lines per sq. cm., show that a limit to the intensity of magnetization attainable is soon reached, practically in a field of 1000 lines of induction per cm². We undoubtedly have the isthmus effect coming in when these small magnets are magnetized by placing them between the faces of an electromagnet; thus in B_1 which was magnetized in a field (undisturbed) of 2200, an average intensity of magnetization of 284 is reached, which must correspond to an average remanent induction of at least 3500.

Effect of Length and Cross Section of Magnets.—The experiments made on the group of fine hair-spring magnets H_1 to H_7 , all taken from one piece tempered glass hard in water, shows the variation of the magnetic moment with the length. These results are plotted in a curve, fig. 6 (p. 260), which shows that, for short magnets, the magnetic moment decreases much more rapidly than in proportion to the length.

The effect of cross section on the intensity of magnetization is shown by comparing, e. g., H_6 and B_3 , the average intensity of magnetization in H_6 (although shorter) being more than 2.7 times that in B_3 . Similarly A_5 (width reduced by grinding), although shorter, has a considerably greater intensity of magnetization than A_3 . This strongly emphasizes the fact that probably the greatest gain in sensibility at present at our disposal is in the use of a number of magnets of small cross section instead of one (or so) of large section, i. e., if you have a given mass of magnetic material (to be made up of magnets of a given length), the system will be considerably more sensitive if you use a number of magnets of small cross section. This brings up at once the question whether, when you divide up the magnetic material into a number of thin magnets, you do not in the end lose what you gained in magnetic moment by subdivision, by the fact that in galvanometer systems the magnets must be placed very near together and so tend by their mutual action to weaken one another.

Mutual Action of Magnets.—This question was investigated for many sizes of magnets and under various conditions; one or two experiments will, however, be sufficient to show that the effect is much smaller than is usually supposed. To study this the magnets B_1 were fastened to one of the brass inertia discs, magnetized, and period determined, in an exhausted receiver, when the distance between the centers of the magnets was 3.3^{mm}; the magnets were then pushed together until the distance between the centers of the magnets was 1.2^{mm}, when the

period was again determined; magnets then pushed apart, etc. The results are shown in the following table:

Distance between Centers of Magnets.	T Time of Vibration of Disc.	M Magnetic Moment C. G. S. Units.
3·2 ^{mm}	2·618 ^{secs}	0·1251
1·2	2·718	·1160
3·2	2·659	·1212
1·2	2·725	·1155
3·2	2·663	·1209
1·2	2·727	·1153
3·2	2·666	·1206

These experiments show that the first near approach of the magnets produced a permanent decrease in the magnetic moment amounting to about 4 per cent (this was to be expected inasmuch as these magnets had not been aged). After that it will be seen that the magnets practically regain their former magnetic moment on separation. The temporary decrease in magnetic moment due to mutual action is less than 5 per cent.

A similar set of experiments with the shorter magnets, B₃, gave a decrease of 5·5 per cent due to mutual action when the center lines of the magnets were 1^{mm} apart. When the magnets were pushed together so that they touched their neighbors throughout their length, the magnetic moment continued to decrease for some minutes until the decrease amounted to 19 per cent, and on separating them they did not recover but were permanently weakened about 10 per cent.

Quality of Steel.—Under similar conditions magnets of Jonas & Colver's special magnet steel* (probably tungsten steel) have moments about 25 per cent greater than those made from watch hair-spring, which is the next best material.

Effect of Jars, etc.—Magnets B₁, 4^{mm} long, dropped twenty times though 30^{cm} on to a glass plate diminished only $\frac{1}{5}$ per cent in magnetic moment; with magnets B₃, 1^{mm} long, the change was less than 1 per cent. Boiling immediately after magnetization reduces the moment by 10 per cent or 15 per cent, and most of the loss occurs during the first few minutes of boiling.

Paschen† has called attention to the fact that to increase the sensibility, for a given period, we must increase the total magnetic moment \bar{M} and decrease the moment of inertia, K . Assuming that the magnetic moment is proportional to the volume, i. e., for a given cross section proportional to the length of the magnet, and that the inertia of the non-magnetic

* From Boker & Co., N. Y.

† Wied. Ann., xlviii, 282.

material could be neglected, Paschen showed that if two systems were made with magnets of the same cross section but of lengths l and $\frac{l}{n}$ respectively, then the second should give a

deflection n^2 times as large as the first system, for if
 the magnetic moment of the first system = M_1
 and the moment of inertia " " " = K_1

then

the magnetic moment of the second system = $\frac{M_1}{n}$

and the mom. of inertia " " " = $\frac{K_1}{n^3}$

The deflection of first system is proportional to

and " " " second " " proportional to $\frac{M_1}{n} \bigg/ \frac{K_1}{n^3}$

i. e., the deflection of the second system is n^2 times that of the first system. The assumption (that $M \propto l$ for given cross section) on which the deduction is based is not even approximately true for short magnets, as the preceding experiments show, but it does at least indicate an advantage in favor of short magnets. This deduction is supported by experiment. Thus Paschen found by testing three similar systems having magnets 4^{mm}, 2^{mm}, and 1.3^{mm} long respectively, made from the same fine hair-spring, that the second gave three times the deflection and the third six times the deflection of the first system.

From curve 1 it will be seen that, if the moment of inertia of the non-magnetic parts of the system can be neglected in comparison with that of the magnetic (a condition which can perhaps be realized even with systems as light as 2 mg. total weight) the sensibilities of two systems having magnets 2^{mm} and 1^{mm} long respectively, of the same material and cross section, would be proportional to

$$\frac{M_1}{K_1} = \frac{5.2}{(2)^3} \quad \text{for system 1}$$

$$\frac{M_2}{K_2} = \frac{1.38}{(1)^3} \quad \text{for system 2}$$

i. e. the second system would be about twice as sensitive as the first, instead of four times as deduced by Paschen on the assumption that $M \propto l$ for given cross section.

If it were always possible to use enough magnets, so that the non-magnetic moment of inertia could be neglected, then the

sensibility would continue to increase as the magnets decreased in length. This not being the case in general, it is possible to use too short magnets. To show this we have calculated the sensibilities to be expected with four systems made of the same material and cross section as magnets I_2 (see table), which showed a greater intensity of magnetization than any others of the same length. Furthermore we assumed that only four such magnets were to be used in each group, to be $.65^{\text{mm}}$ long in the first system, and 1^{mm} , 1.5^{mm} , 2^{mm} in the others; that the mirror weighed $.23$ mg., and was $1^{\text{mm}} \times 1.1^{\text{mm}}$ in area, the staff

Fig. 5

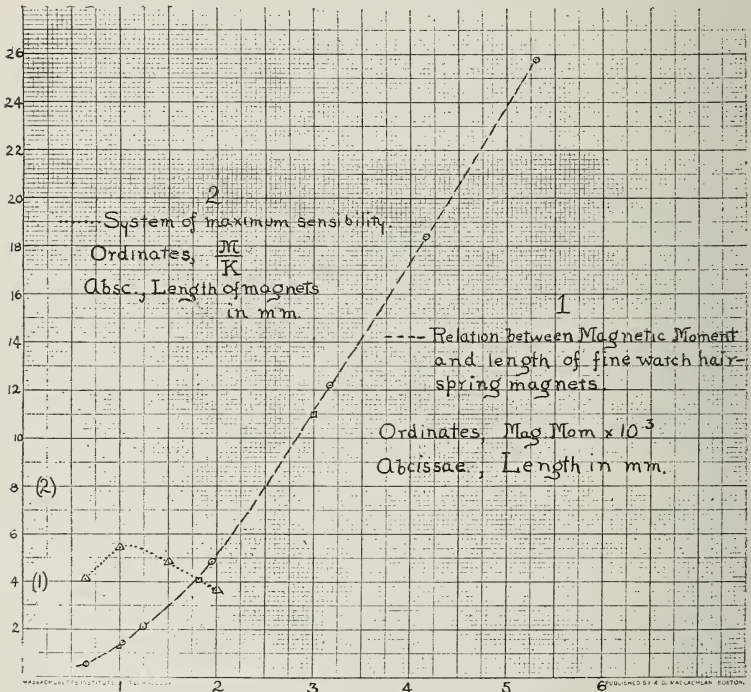

and shellac weighed $.09$ mg., and the hook $.06$ mg.—these values being found by trial. Except for the omission of the hook, which is readily dispensed with, it would be difficult to reduce the non-magnetic mass much below this. The results are shown in curve 2—where ordinates are proportional to sensibility, and abscissæ to length of magnets used. A very decided maximum is shown, for a length of 1.1^{mm} . It must be said, however, that the magnets could be put closer together without undue demagnetization, and that two sets could be

mounted, one on each side of the staff, thus increasing the number from eight to twenty; this would require shorter magnets for maximum sensibility.

We have not yet exactly realized this system in practice, but give the result obtained with a system having only six magnets, of the same material and cross section as I_2 , and an average length of about 1.16^{mm} ; the non-magnetic moment of inertia was probably a little less than that assumed in the above calculation. The sensibility actually obtained, and also the sensibility reduced to the Ayrton-Mather scale, is given in the following table, together with the sensibilities of a few other recent galvanometers, taken from the table of Ayrton and Mather (Phil. Mag., Oct., 1898).

It should be noted that with these very light systems the "period" when it is at all long—say 5° to 10° complete—is very difficult to determine, on account of the great damping. Moreover, it is unfair to compare systems which were tested at considerably different periods, and reduced to the same period by assuming the sensibility $\propto T^2$ —for this is on the basis of a *free* period.* In computing moments of inertia for the above systems, we have assumed that the axis of rotation passed through the center of gravity of the system and was parallel to the staff; if the system is badly constructed so that the axis of rotation departs $.2^{\text{mm}}$ from the staff at its upper extremity, the moment of inertia will of course be increased, and the sensibility (for a given period) decreased by about 25 per cent. The moments of inertia of the four systems computed for use in plotting curve 2 varied between 44×10^{-8} and 529×10^{-8} C. G. S. units.

TABLE.

Galvanometer and Constants when tested.	Suspension System.	Sensibility and conditions of use when tested.	Deflections per micro-ampere when scale dist.=1000 scale divs., complete period = 10 secs. Resistance =1 ohm.
Snow (Wied. Ann. xvii, p. 218; Phys. Rev., i, p. 37). 4 coils, 30mm. ext. and 6mm. int. diam. Each coil wound in 2 sections, with 1800 turns. $R = 140 \text{ ohms}$ (series)	6 small watch-spring magnets in each group, 3 on each side of staff. Magnets 3-4 mm. long. Mirror 5 mm. dia., 0.14mm. thick. Quartz fibre 40cm. long. Wt. of system = 80mg.	$C = 1.5 \times 10^{-11} \text{ amp. per mm.}$ Scale dist. = 300cm. T (complete) = 10 secs. $R = 140 \text{ ohms.}$	470

* See Ayrton and Mather, Phil. Mag., pp. 366, 1898.

Galvanometer and Constants when tested.	Suspension System.	Sensibility and conditions of use when tested.	Deflections per micro-ampere when scale dist.=1000 scale divs. complete period = 10 secs. Resistance =1 ohm.
<p>Wadsworth (Phil. Mag., xxxviii, p. 553). 4 coils, 50mm. ext. diam., 2mm. int. and 40mm. deep. Each coil wound in 5 sections, with 2396 turns. $R=86\text{ ohms}$ (series)</p>	<p>10 small magnets in each group (5 on each side of staff, varying from 2-3mm. in length) made from smallest size sewing needles (untreated). Glass 150 mm. long, weighs 5mg. Mirror (concave) 2.5mm. diam. and weighs 12mg.</p>	<p>$C=4 \times 10^{-11}\text{ amp. per mm.}$ Scale dist.=100cm. T (complete)=20 secs. $R=86\text{ ohms.}$</p>	675
<p>Nichols E. L. and E. F. (Phys. Rev., i, p. 2). $R=9.3\text{ ohms}$ (parallel)</p>	<p>Wt. of system=48mg.</p>	<p>$C=1.3 \times 10^{-10}\text{ amp. per mm.}$ Scale dist =150cm. T (complete) =10 secs. $R=9.3\text{ ohms.}$</p>	2200
<p>Paschen Wied. Ann., xlviii, p. 284). 4 coils, 40mm. external and 5mm. internal diam. Wound with graded wire, about 1200 turns in each coil. $R=60\text{ ohms.}$</p>	<p>Each group has 13 magnets 1 to 1.5 mm. long, on both sides of glass staff 0.3mm. apart; Mirror 2mm. dia. 0.03mm. thick. 5cm. quartz fibre. Wt. of system =5mg.</p>	<p>$C=3.3 \times 10^{-12}\text{ amp. per mm.}$ Scale dist.=300cm. T = 15 secs. (aperiodic, i. e., has only one turning point). $R=60\text{ ohms.}$</p>	5800
<p>Mendenhall and Waidner. 4 coils, ext. diam. =15mm., internal diam. = 2 mm. 6 sizes of wire, 500 turns on each coil. $R=3\text{ ohms}$ (in parallel)</p>	<p>3 magnets in each group. Total wt. 1mg. Wt. of magnetic part of needle =.68mg., length of magnets =1.15mm. Plane mirror, .9mm. x 1mm.</p>	<p>$C=5.6 \times 10^{-11}\text{ amp. per mm. deflection.}$ Scale dist.=200cm. T=9 sec. complete aperiodic (i. e. has only one turning point). Zero stable. $R=3\text{ ohms.}$</p>	6090

*Thompson Physical Laboratory,
Williams College.*

ART. XXVIII.—*On a Method of Locating Nodes and Loops of Sound in the Open Air with Applications*; by BERGEN DAVIS, P.H.D.

THE experiments and determinations given in this article constitute an application of a new phenomenon recently described by the writer in this Journal.* It is now my wish to point out how the device previously described can be used to locate nodes and loops of sound waves outside of organ-pipes, and in general how the mechanical effects produced by sound waves, at a distance from this source, can be studied.

It having been found that a small hollow cylinder which is closed at one end, will move across a stationary sound-wave in a direction perpendicular to the stream-lines, a small mill-like arrangement was constructed by placing four hollow cylinders on the ends of card-board arms, in such a manner that the closed ends pointed in the same angular direction. This mill was provided with a glass pivot at its center, and was supported on the point of a fine needle.

The cylinders were made from No. 00 gelatine capsules, and were each 1.7^{cm} long and .79^{cm} in diameter. This system was mounted in the mouth of a resonator, with the plane of the system parallel to the mouth, and hence perpendicular to the direction of vibration. The aperture of the resonator, with the mill in place, is shown in figure 1. The resonator was in unison with an organ-pipe of considerable power, and when the pipe was blown the mill was found to rotate with a high velocity, and the rate of rotation was different for different positions in the room. By carrying the resonator around a large room, the positions of the nodes and loops could be located with considerable accuracy.

The resonator containing the mill was next carried to another large room, on the floor above that where the pipe was located: there was no opening in the floor or ceiling between the rooms, and the doors of both rooms were tightly closed, but in spite of this, the mill was observed to rotate as before, but not so rapidly. Nodes and loops could be located here also.

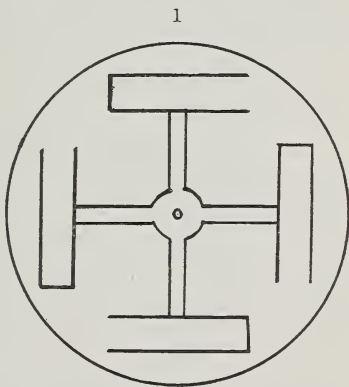

* Bergen Davis, this Journal, Sept., 1901, p. 185.

In order to avoid reflection from walls, and the consequent formation of stationary waves, the pipe was then carried out of doors, and compressed air led to it by a long rubber pipe. Here, in the open air, the mill was found to rotate very rapidly when near the pipe, and the rate decreased with the distance from the pipe, ceasing to rotate at about 60 feet from the pipe. This distance could probably be very much increased by the use of more delicate apparatus, especial care being taken with the pivot and needle point. This furnishes a means of studying the decrease of intensity with distance, and, with the aid of the formula developed by Lord Rayleigh,* of measuring the actual amplitude of the vibration at various points in the open air.

A very sensitive sound detector of this character might be made by suspending a system of very small cylinders in the mouth of the resonator by means of a quartz fiber, and then observing the deflection by a mirror and telescope. Such an instrument ought to be as sensitive as the one constructed by Boys, who used a suspended disc for the same purpose.† An instrument of this kind, perhaps, might be useful in investigating the acoustic properties of buildings, also in the study of the reflection, refraction and absorption of sound.

Physical Laboratory, Columbia University,
June 15, 1901.

* Theory of Sound, II, pp. 195-200.

† Boys, Nature, vol. xlii, p. 604.

ART. XXIX.—*The Anatomy of the Fruit of Cocos nucifera* ;*
by A. L. WINTON.

[Contribution from The Connecticut Agricultural Experiment Station, New Haven, Conn.]

I. MORPHOLOGY AND MACROSCOPIC STRUCTURE.

SINCE the general structure of the cocoanut fruit has been treated by numerous writers on systematic and economic botany, only such facts are here given as are essential for a clear understanding of the relation of the parts and the microscopic structure.

The flowers are arranged in spikes branching from a central axis and inclosed with a tough spathe usually a meter or more in length (fig. 1). A single female flower is borne near the base of each lateral axis, and numerous male flowers are distributed on all sides of the axis between the female flower and the apex. After the male flowers drop, each naked lateral axis persists and is a prominent appendage of the fruit (figs. 2 and 3, *S*). Only one ovule of the three-celled ovary comes to maturity, but the tricarpelary nature of the fruit is indicated by its triangular shape as well as by the longitudinal ridges and the three eyes or germinating hole of the nut.

The epicarp of the fruit (fig. 3, *Epi*) is a smooth tough coat, of a brownish or grayish color.

The mesocarp (fig. 3, *Mes*), consists of a hard outer coat but a few mm. thick and a soft portion usually 3–4^{mm} thick on the sides and much thicker on the base. Imbedded in the mesocarp are numerous longitudinally arranged fibers, varying in size from slender hairs to large, sparingly branching and anastomosing, flattened forms, 2–3^{mm} broad. The large fibers are situated chiefly in the inner layers, with their flat surfaces parallel with the surface of the nut.

Oftentimes the inner layers of the mesocarp become impregnated with a brown fluid, which on drying, gives the thin tissue a mottled brown appearance.

* European microscopists have studied the foods and adulterants which have come under their observation but have overlooked a number of distinctly American products. The writer has undertaken to fill in some of these gaps by a series of papers, of which this is the second. The first paper, on the anatomy of maize cob, was published in the *Oesterreichische Chemiker-Zeitung*, 1900, p. 345, and also in the Conn. Experiment Station Report, 1900, p. 186.

Each paper will describe from the purely scientific standpoint the macroscopic and histological structure of the material investigated, and also in a final chapter point out the application of this knowledge to the detection of adulteration. The last chapter is not strictly suited to the pages of this Journal, but is so dependent on the scientific descriptions which precede it that it would be almost valueless if published separately.



FIG. 1. Inflorescence of the cocoanut showing spathe inclosing the spikes, each with numerous male flowers above and a single female flower near the base. $\times \frac{1}{5}$.



FIG. 2. Half grown cocoanut fruit with calyx, and axis from which the male flowers have fallen. $\times \frac{1}{5}$.



FIG. 4. Inner surface of a cocoanut shell with adhering outer testa. At the left the raphe, from which proceed veins forming a network over the surface. $\times \frac{1}{5}$.

The endocarp, or shell (fig. 3, *End*), consists of a hard, dark brown coat, 2–6^{mm} thick, with numerous fibers adhering to the surface. Three nearly equidistant ridges (often indistinct) pass from base to apex, where they unite to form a blunt point. At the basal end, between the ridges, are the three depressions or eyes, the tissues of which are much softer and thinner than of the rest of the shell (fig. 3, *K*). Through the softest of these eyes the embryo, embedded in the endosperm directly behind it, escapes in sprouting.

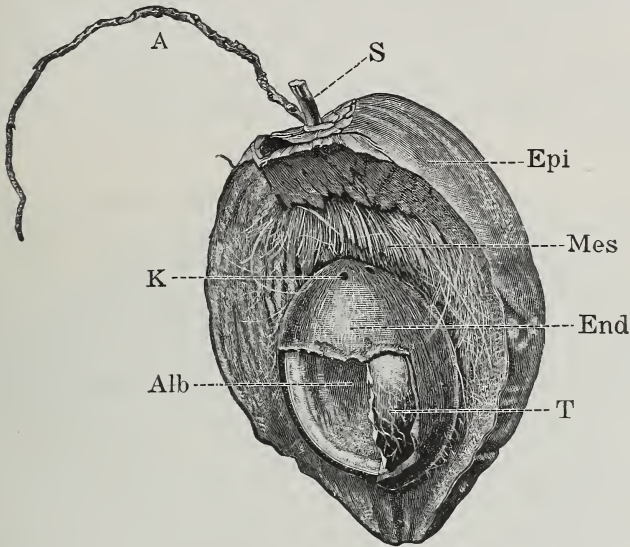

FIG. 3. Ripe coconut fruit. *S*, lower part of axis forming the stem; *A*, upper end of axis with scars of male flowers; *Epi*, epicarp; *Mes*, mesocarp with fibers; *End*, endocarp or hard shell; *T*, portion of testa adhering to endosperm; *Alb*, endosperm surrounding cavity of the nut; *K*, germinating eye. $\times \frac{1}{3}$.

The testa of the anatropous seed (fig. 3, *T*, and fig. 4) is a thin coat of a light brown color, closely united with the endocarp without and the endosperm within. Embedded in the outer portion and extending from the principal eye nearly to the apex is the raphe, consisting of a thin band of vascular tissues about 1^{mm} broad, which sends off branches in all directions, forming a network about the seed. The endosperm with the inner portion of the testa may be separated from the outer testa and endocarp by introducing a knife blade between the layers. By this operation the veins are split, part of the vascular tissue adhering to the convex surface of the inner testa, and the remainder to the concave surface of the outer testa, so that both surfaces are covered with reticulations.

The endosperm or meat of the cocoanut (fig. 3, *Abb.*) is a white, fleshy layer, 1–2^{cm} thick, in which, near the base, is embedded the small embryo. While immature, the nut is filled with a milky liquid and has no solid endosperm, but as the ripening proceeds the endosperm is gradually formed and at the same time the milky liquid diminishes in quantity or entirely disappears.

Cocoanuts yield food for man and cattle, oil, fiber, and other useful products. The epicarp and mesocarp are cut away from nuts designed for export, although invariably a small amount of the mesocarp with its fibers remains attached to the shell. In removing the meat, the outer testa, as has been stated, also adheres to the hard shell, so that cocoanut shells consist not merely of endocarp, but also of a certain amount of mesocarp and testa.

II. HISTOLOGY.

The microscopic structure of the cocoanut seed is described by Hanausek,* Harz,† Moeller,‡ Koenig§ and other authorities on foods and applied microscopy.

Cocoanut fiber (coir), which has long been extensively employed in making mats and cordage, and also cocoanut shell, which has been used for making knobs and other turned articles, were studied by Wiesner|| nearly thirty years ago, but his work was designed chiefly to distinguish the fiber from other commercial fibers and the shell from the similar shell of *Attalea funifera*.

Von Hoehnel¶ describes briefly the histology of coir, but, like Wiesner, does not appear to have understood the true nature of the stigmata.

Weiss,** Engler and Prantl,†† and some other authors refer briefly to the microscopic structure of parts of the cocoanut, but their descriptions are of little value in diagnosis.

1. *Epicarp.*

The epicarp or epidermal layer is about .015^{mm} thick and is made up of tabular cells with dark brown contents. In surface view the cells are usually square, rectangular or tri-

* Die Nahrungs- und Genussmittel aus dem Pflanzenreiche, Kassel, 1884, p. 155.

† Landwirtschaftliche Samenkunde, Berlin, 1885, p. 1120.

‡ Mikroskopie der Nahrungs- und Genussmittel aus dem Pflanzenreiche, Berlin, 1886, p. 241.

§ Die Untersuchung landwirtschaftlich u. gewerblich wichtiger Stoffe, Berlin, 1898, p. 291.

|| Die Rohstoffe des Pflanzen-Reiches, Leipzig, 1873, pp. 436 and 789. (A new edition is being published in parts, but the chapters on the cocoanut have not yet appeared.)

¶ Die Microscopie der technisch verwendeten Faserstoffe, Leipzig, 1887, p. 52.

** Anatomie der Pflanzen, Wien, 1878, 1 Band.

†† Die natürlichen Pflanzenfamilien, II Theil, 3 Abteilung, p. 22.

angular, with double walls about $.005^{\text{mm}}$ thick and are arranged with some regularity in rows.

2. *Mesocarp*.

(a) *Hard ground tissue*.—This tissue consists of thick-walled cells which are often tangentially-transversely elongated. In the first few layers the walls are about the same thickness as in the epidermis, without evident pores, but further inward they are more strongly thickened (double walls often $.015^{\text{mm}}$ thick) and conspicuously porous. Still further inward they pass into the parenchyma of the soft ground tissue.

(b) *Bast-fiber bundles*.—In the hard ground tissue the bundles have no phloem or xylem but are composed entirely of bast-fibers with cell walls often thicker than the lumen. The number of fibers seen in cross section varies from two or three

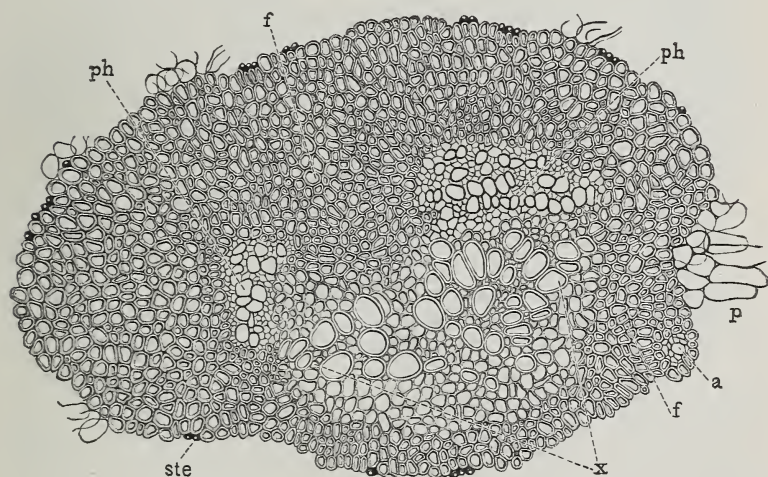

FIG. 5. Transverse section of a large flattened (mesocarp) fiber of the coconut. *ste*, stegmata; *f*, sheath of bast fibers; *ph*, two phloem groups; *x*, xylem; *p*, parenchyma of ground tissue; *a*, rudimentary bundle belonging to small branch. $\times 90$.

up to a hundred or more. Transitional forms between fibrous and fibro-vascular bundles occur further inward.

(c) *Soft ground tissue*.—The thin-walled parenchyma cells of the soft ground tissue are in some parts isodiametric, in other parts longitudinally elongated, and in still other parts transversely-tangentially elongated (fig. 8, *w*). Wherever the brown liquid previously referred to has penetrated the inner layers of the mesocarp, groups of the parenchyma cells here and there, being impregnated with this material, are of a rich brown color and appear thicker-walled than the others (fig. 8,

br.). This brown substance is quickly changed to a reddish color by caustic potash, but is not affected by alcohol, ether or the specific reagents for proteids, fats and resins. No immediate effect is produced by ferric chloride solution, but on long standing the color is changed to olive green.

(d) *Fibers (Coir)*.—These are fibro-vascular bundles with a strongly developed sheath of bast-fibers. Toward the xylem side of the bundle, particularly in the large fibers, the sheath usually diminishes in thickness and the vascular portion, as seen in cross section, is more or less eccentric, surrounded by a crescent-shaped sheath with the horns connected by a narrower strip.

In the smaller fibers there is but one group of phloem elements, but in the larger flattened fibers there are usually two, or occasionally more, groups separated from each other by a continuation of the sheath (fig. 5). Normally the xylem is near the inner flat side and the two phloem groups are approximately symmetrical with reference to the shorter axis of the elliptical cross section; but often the xylem is near one of the narrow sides and the phloem groups are symmetrical with reference to the longer axis, and still more often the arrangement is diagonal or otherwise irregular.

Mohl* in 1831 noted that the phloem in the stem of *Calamus* was normally divided into two distinct groups, and Kny† as well as other authors have since found the same arrangement in a number of palms. By the study of many sections, the writer has demonstrated that a cocoanut fiber with two phloem groups has also a double xylem, although in most sections no separation is evident, and the whole fiber consists of two simple bundles united side by side, which may completely separate further on in their course by the forking of the fiber.

Serial sections cut through such compound fibers show that at the place of forking the phloem groups are still further separated and the xylem also is divided by bast-fibers, thus forming two distinct bundles which pass into the two branches. The phloem in each branch is at first entire, but further on, if the branch is large it usually divides, and still further on the whole bundle may split up, with the formation again of two fibers. Occasionally a fiber which has no evident division of the xylem has four groups indicating that the fiber is composed of four united bundles, which, on branching, form two fibers each with a double bundle.

Large fibers not only fork but also send off small lateral branches. The rudimentary bundles belonging to such

* De Palmarum Structura, Translation in Ray. Soc. Reports and Papers, 1849, p. 29.

† Verhandl. d. Bot. Ver. Prov. Brandenburg, Bd. xxiii, 1881, pp. 94–109.

branches may often be seen in cross sections of the trunk fiber below the place of branching (fig. 5, *a*).

a. Stegmata (figs. 5 and 6, *ste*).—As seen in surface view these are circular or elliptical cells from $\cdot008$ to $\cdot020$ mm in diameter, which extend in longitudinal rows over the surface of the fibers. Longitudinal sections show that the cells are biconvex, fitting into depressions in the bast-fibers, and that the outer walls are exceedingly thin, while the inner and side walls are strongly thickened, thus bringing the cell cavity near the outer surface. Inclosed in each cell and filling it almost completely, is a silicious body, from $\cdot006$ to $\cdot012$ mm in diameter, with wart-like protuberances on the surface which fit into corresponding depressions in the cell walls (fig. 7). That they are composed

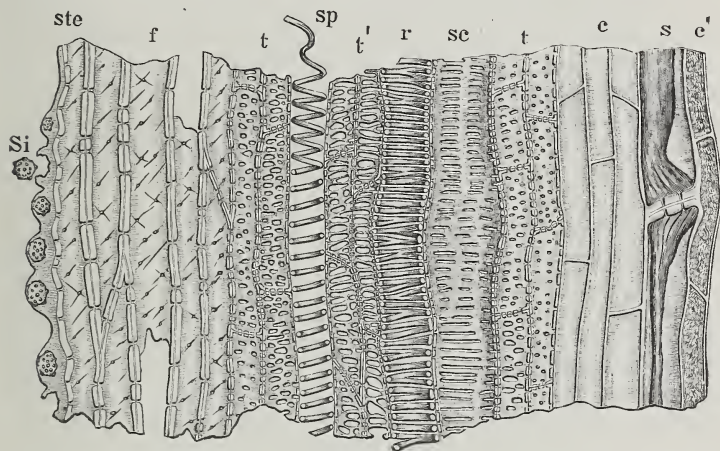

FIG. 6. Longitudinal section of a large (mesocarp) fiber of the cocoanut. *ste*, stegmata; *Si*, silicious body; *f*, bast fibers; *t*, tracheids with small pits; *t'*, tracheids with large pits; *sp*, spiral trachea; *r*, reticulated trachea; *sc*, scalariform trachea; *s*, sieve tube; *c* and *c'*, cambiform cells. $\times 300$.

of silica is demonstrated by their incombustibility, their insolubility in hydrochloric and nitric acids and their complete solubility in hydrofluoric acid. Their appearance is particularly striking in tangential sections which have been heated on a cover glass until thoroughly carbonized and finally treated with hydrochloric acid on the slide. The heating should be performed at dull redness, since at a higher temperature the bodies lose their characteristic appearance.



FIG. 7. Silicious bodies from the stegmata of cocoanut fiber. $\times 1500$.

Wiesner* refers to these stegmata as "bast parenchyma," and from his description it would appear that he considered them

* Loc. cit., pp. 436-438.

silicified cells and did not understand that they are *sclerenchymatized cells* with *silicious contents*. Von Hoehnel,* who uses, however, the term "stegmata," also appears to have fallen into the same error.

Rosanoff† found stegmata in twelve species of palms, and Kohl,‡ who has made an exhaustive study of the subject, in twenty-three additional species. Neither author mentions *Cocos nucifera*, but Kohl found in *C. flexuosa* stegmata with silicious contents which answer the description of those in coir fiber.

β. Bast-fibers (figs. 5 and 6, *f*) completely surround the bundle. They vary in length up to 2^{mm} and in diameter up to .03^{mm}. The double cell walls are from one-half to one-sixth the breadth of the lumina, with conspicuous pores and diagonal markings. In longitudinal section the walls adjoining the stegmata are sinuous in outline, due to the depressions into which the stegmata are fitted. On the edge of the xylem the bast-fibers pass into tracheids (fig. 6, *t*).

γ. Xylem (fig. 5, *x*; fig. 6). The elements are tracheæ, tracheids and various forms intermediate between tracheids and bast-fibers, and tracheids and parenchyma.

The tracheæ range in diameter up to .05^{mm}, the larger (found in large fibers) being reticulated (fig. 6, *r*) or scalariform-reticulated (*sc*), the smaller (found both in large and small fibers) being spiral or reticulated spiral. Among the spiral tracheæ one finds considerable variation both as to their size and the steepness of their spirals. As might be expected, those in the protoxylem often have delicate spirals with turns wide apart. An intermediate form is shown in fig. 6 (*sp*).

The tracheids, distinguished from the tracheæ by the transverse or diagonal partitions and by their smaller size and thinner walls, likewise display an interesting diversity of size and form. Among these are forms with large pits and curious reticulations (fig. 6, *t'*), also transitional forms between tracheids and bast-fibers (*t*) on the one hand, and tracheids and parenchyma on the other.

δ Phloem. Sieve tubes and cambiform cells make up the phloem (fig. 5, *ph*).

Measured in cross sections, the diameters of the sieve tubes vary up to .03^{mm}. In longitudinal sections it may be seen that the sieve plates are either at right angles to the walls or oblique and that oftentimes they are covered with callus through which run a few indistinct pores (fig. 6, *s*).

* Loc. cit., p. 52.

† Bot. Ztg., 1871, p. 749.

‡ Kalksalze und Kieselsäure in der Pflanze, Marburg, 1889, p. 289.

Cambiform cells occur singly, in rows and in groups among the sieve tubes and also at the edges of the phloem. Those among the sieve tubes are for the most part small (about $\cdot 003^{\text{mm}}$ in diameter), prismatic and with abundant protoplasmic contents (fig. 6, *c'*). They correspond to the "*geleitzellen*" of Wilhelm, Tschirch* and other authors except that the walls adjoining the sieve tubes, so far as the writer has observed, are not pitted.

At the edges of the phloem, particularly adjoining the xylem, the cambiform cells are larger (often $\cdot 01^{\text{mm}}$ in diameter) and are often empty. The differences between these forms are, however, so slight and perplexing that the writer, following the example of De Bary and Strassburger, prefers to group them all under the head of Cambiform cells.

(ϵ) Intercellular spaces, such as occur in the protoxylem of many monocotyledinous plants, are seldom, if ever, seen in coir fibers, but oftentimes, although less commonly than in the hard shell, the phloem and part of the xylem are destroyed during growth, leaving a channel in the bundle.

3. *Endocarp*.

This coat, known commonly as the shell (fig. 8, *end*), is a dense aggregation of stone cells, among which run longitudinally partially destroyed bundles.

(a) *The stone cells* with their thick, deep yellow walls, branching pores, and dark brown contents, present a striking and characteristic appearance. They are either isodiametric or strongly elongated, the latter (often $0\cdot 2^{\text{mm}}$ long) being usually spindle or wedge-shaped, although hammer-shaped, hooked and various other curious forms abound.

A study of sections shows that the elongated cells are arranged in groups, commonly with the longer diameters in tangential-transverse directions and are best seen in cross sections of the shell (fig. 8, *gst*), but in some groups, particularly those adjoining the bundles, they pass longitudinally about the shell (fig. 9, *lst*). It is evident from fig. 8 that more than half of all the stone cells are tangentially-transversely elongated. Those which appear isodiametric (*lst*) are partly cells which are isodiametric in three dimensions and partly longitudinally elongated cells in section.

Groups of thinner-walled cells with dark brown contents are occasionally met with.

The brown contents of all the endocarp cells react the same as the brown impregnating material of the mesocarp.

(b) *Vascular bundles* are studied with difficulty in the mature shell. By the rupture of the phloem and part of the

* See Tschirch, *Angewandte Pflanzenanatomie*, Wien, 1889, p. 349.

xylem during growth, passages are formed, which, in shells transversely cut or broken, are evident to the naked eye as

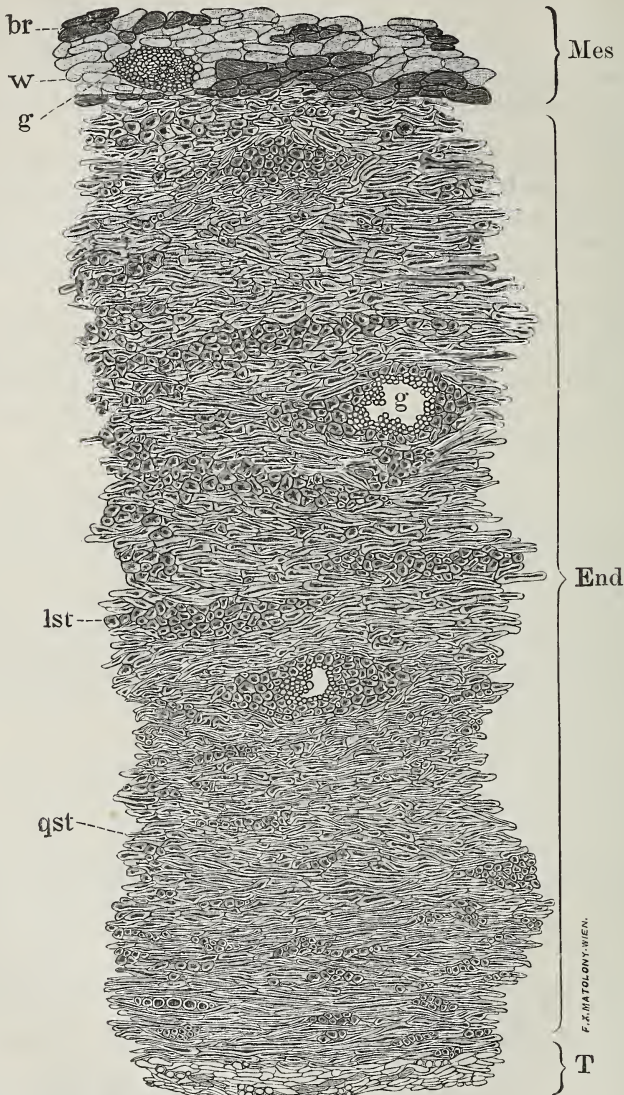

FIG. 8. Transverse section of a cocoanut shell. *End*, endocarp or hard shell; *Mes*, adhering mesocarp; *T*, adhering outer testa; *w*, colorless parenchyma of mesocarp ground tissue; *br*, same as *w* but impregnated with a brown substance; *g*, vascular bundles, in the endocarp with phloem and xylem partially obliterated; *1st*, longitudinally elongated and isodiametric stone cells; *qst*, transversely elongated stone cells. $\times 60$

minute holes. The structure of the bundles is still further obscured by the presence of fungus threads and spores.

In structure the bundles differ from those of the mesocarp fiber, the bast-fibers being replaced by forms intermediate between fibers and tracheids (fig. 9, *f*). The vascular elements are chiefly spiral tracheæ (*sp.*), and pitted tracheæ (*g*), the latter being especially noticeable.

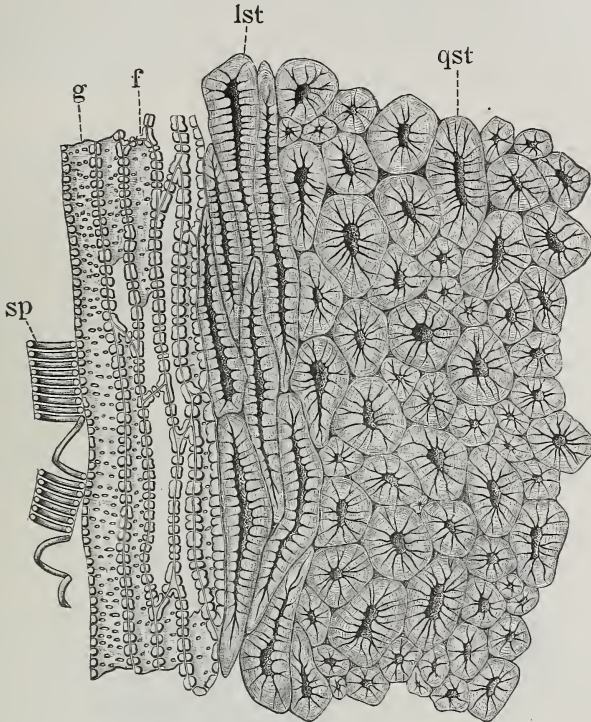

FIG. 9. Longitudinal-radial section of cocoanut endocarp through the stone cells and edge of bundle. *qst*, transversely elongated and isodiametric stone cells; *lst*, longitudinally elongated stone cells; *f*, thick-walled porous cells; *g*, pitted trachea; *sp*, spiral trachea. $\times 306$.

4. Testa.

Several microscopists have studied the testa, but, owing doubtless to differences in the material, hardly two of them agree as to the number of coats or the character of the elements. The description which follows is based on the examination of numerous specimens.

(a) *Outer testa*. This coat consists of a ground tissue of large, variously shaped cells, crossing one another in all directions, (fig. 8, *T*, fig. 10), between which ramify the veins.

Most of the ground tissue cells have colorless double walls, from $\cdot 004$ to $\cdot 010^{\text{mm}}$ thick, with conspicuous (sometimes large) pores, but in the inner layers they often have thinner walls without evident pores and except for their shape bear no resemblance to the other cells.

As a rule, the cells are empty, but some here and there contain a brown substance apparently the same as is contained in the mesocarp and endocarp, which often takes the form of spheres (fig. 10, *k*), disks, or films with circular openings (*v*).

Colorless stone cells (fig. 10, *st*) are present in the outer layers and contrast strikingly with the deep yellow stone cells of the endocarp.

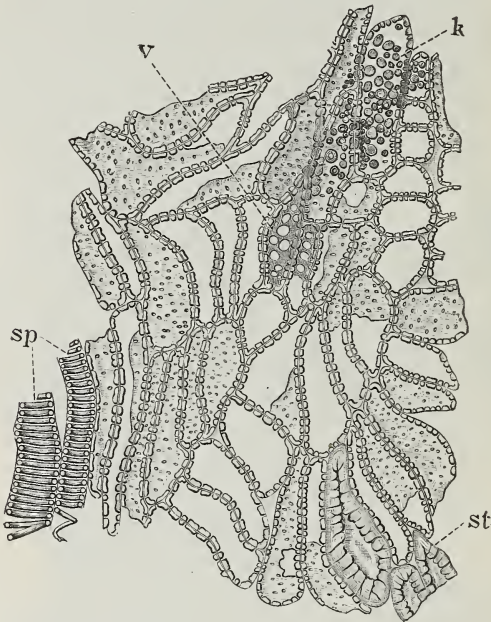

FIG. 10. Tangential section of the outer testa of the cocoanut showing the ground tissue of thick-walled porous cells. Most of these are empty, but a few contain brown contents in the form of globules, (*k*) or films with circular openings (*v*). *st*, colorless stone cell; *sp*, spiral trachea. $\times 300$.

The conspicuous elements of the veins are spiral tracheæ, pitted tracheæ and elongated cells intermediate between pitted tracheæ and the porous cells of the ground tissue, and are not distinguishable from the same elements of the endocarp bundles. (See fig. 9, *sp*, *g* and *f*.)

In breaking away the meat, the separation is through the middle of the veins and the inner layers of the outer testa,

nearly all the ground tissue and about half of the vascular elements remaining on the inner surface of the shell.

(b) *Inner testa*. Firmly attached to the endosperm are from ten to twenty layers of small isodiametric or slightly elongated cells. The double walls are about $\cdot 003^{\text{mm}}$ thick and free from pores. These cells contain a material varying in color from light yellow to dark brown, which either fills them completely or occurs in globules, films, etc., as in some of the cells of the outer tests. In the layer adjoining the endosperm the cells are smaller and have darker brown contents than the cells in the other layers.

5. *Endosperm*.

Although the microscopic character of the endosperm has been fully explained by Harz, Hanausek and Moeller, a brief description is here given to accompany the descriptions of the other parts of the fruit.

In the outer layers the prismatic cells are nearly isodiametric (about $\cdot 05^{\text{mm}}$ in diameter), but further inward they are radially elongated, often reaching a length of $\cdot 3^{\text{mm}}$. Cell partitions are about $\cdot 003^{\text{mm}}$ thick, without pores.

The cells contain bundles of needle-shaped fat crystals and lumps of proteid matter, each lump containing, as a rule, a crystalloid. Ether and alcohol readily dissolve the fat crystals and strong potassium hydrate solution saponifies them. The proteid bodies give the usual color reactions with iodine, Millon's reagent and dyes.

III. THE DETECTION OF POWDERED COCOANUT SHELLS IN GROUND SPICES.

The adulteration of ground spices with powdered cocoanut shells was brought to notice in 1885 by W. H. Ellis,* public analyst, Toronto, Canada, and has since been frequently detected by A. McGill † of Ottawa and food analysts in different parts of the United States.

The extent to which this fraud is practiced is indicated by the following summary of results obtained by the writer during the years 1896-7 in the examination of samples collected in the State of Connecticut.

	Black pepper.	Cloves.	Allspice.
Samples examined	147	37	24
Samples adulterated (total) . .	47	17	11
Samples adulterated with ground cocoanut shells . . .	21	7	6

* Dept. Inland Revenue, Rep. on Adult. of Food for 1885, Ottawa, 1886, pp. 67, 79.

† Laboratory of the Inland Rev. Dept., Bull. No. 20, 1890, pp. 7-11.

It is stated on credible authority that in Philadelphia at the present time about six hundred tons of shells, obtained as a by-product in the preparation of desiccated cocoanut—an article much used in pastries and confectionery—are annually reduced to a powder in mills of peculiar construction and sold to spice grinders. This powder, without further treatment, is mixed with ground allspice, which it closely resembles in appearance. By cautious roasting the color of ground cloves and nutmegs is matched, and by roasting at a higher temperature a charcoal is obtained which, mixed with starchy matter, is a clever imitation of black pepper.

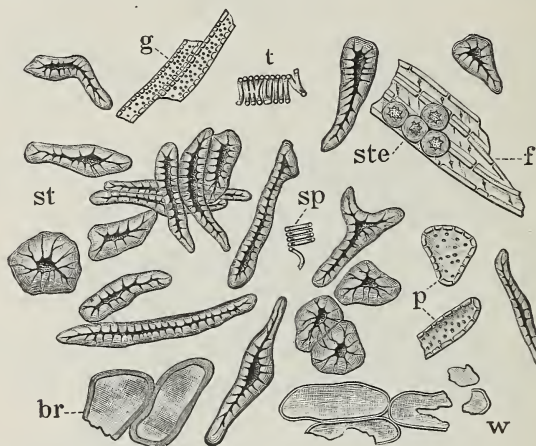

FIG. 11. Cocoanut shell powder. *st*, dark yellow stone cells with brown contents; *t*, reticulated trachea; *sp*, spiral trachea; *g*, pitted trachea; *w*, colorless and *br*, brown parenchyma of mesocarp; *f*, bast-fibers with stegmata (*ste*). $\times 160$.

Powdered cocoanut shells appears to be a distinctively American adulterant. The leading treatises on the microscopy of foods in the German, French and English languages, even those of recent publication, make no mention of it, and a number of prominent European food chemists and microscopists have declared to the writer that they had never heard of its use. On the other hand, cocoanut cake (the residue from the oil presses), which in Europe is commonly employed, both as a cattle food and as an adulterant of human foods, is almost unknown in America.

All the tissue elements of the mesocarp, the endocarp and the outer testa are present in cocoanut shell powder, but the stone cells of the endocarp make up the bulk of the material. (fig. 11, *st*). These cells are characterized by their porous, brown-yellow cell walls, their dark brown contents which

become a reddish brown on treatment with potassium hydrate solution, and the predominance of peculiar elongated forms. They differ in one or more of these characteristics from the stone cells of pepper, allspice, clove stems, walnut shells, almond shells, Brazil-nut shells, hazel-nut shells, peach stones and olive stones.

The outer testa or lining of the shell also forms a considerable part of the powder, the most striking elements being the thick-walled, porous cells (*p*) and the vascular elements.

Colorless cells of the mesocarp ground tissue (*w*) are not distinguishable from the parenchyma of many other plants, but when impregnated with the brown substance which has been described they are striking objects (*br*). Potassium hydrate changes the color of these brown cells to a reddish brown, but ferric chloride does not produce any immediate effect, thus distinguishing them from the brown cells of allspice seed, the color of which potassium hydrate removes and ferric chloride changes at once to a green.

Spiral, reticulated, and pitted tracheæ (*sp*, *t* and *g*), from the mesocarp, endocarp and testa bundles, are also frequently met with in the powder, the pitted trachea being quite unlike any vascular elements of the spices.

The stigmata (*ste*) of the mesocarp fibers with their silicious contents are characteristic, but they are difficult to find owing to the great preponderance of other tissues. Bast-fibers (*f*) are more liable to be encountered than the stigmata, but they furnish less conclusive evidence.

Spices adulterated with charred cocoanut shells show under the microscope black, opaque fragments which are not bleached by aqua regia or nitric acid and potassium chlorate. Except in cases where some of the stone cells or other elements have escaped charring, this material cannot be distinguished from other forms of charcoal.

Chemical analysis is a valuable adjunct to the microscopic examination and often determines approximately the extent of the adulteration, but since other nut shells have a similar composition, the microscope is essential for the identification of the particular adulterant present. As was pointed out by the writer* five years ago, the crude fiber obtained in the process of analysis is particularly suited for the microscopic detection of stone cells and other tissues.

The radical difference in composition between cocoanut shells and the spices to which they are added is shown by the following results by Winton, Ogden and Mitchell.†

* Conn. Agr. Expt. Sta., Rep. 1896, p. 34.

† Ibid., Rep. 1898, pp. 198-211.

	Black pepper. (Av. of 14 analyses.)	Cloves. (Av. of 8 analyses.)	Allspice. (Av. of 3 analyses.)	Nutmeg. (Av. of 3 analyses.)	Cocoanut shells. (1 analysis.)
	%	%	%	%	%
Water	11.96	7.81	9.78	3.63	7.36
Total ash	4.76	5.92	4.47	2.28	0.54
Ash soluble in water	2.54	3.58	2.47	0.86	0.50
Ash insoluble in hydrochloric acid	0.47	0.06	0.03	0.00	0.00
Volatile ether-extract	1.14	19.18	4.05	3.02	0.00
Non-volatile ether extract	8.42	6.49	5.84	36.70	0.25
Alcohol extract	9.62	14.87	11.79	10.77	1.12
Reducing matters by direct inver- sion calc. as starch	38.63	8.99	18.03	25.56	20.88
Starch by diastase method	34.15	2.74	3.04	23.72	0.73
Crude fiber	13.06	8.10	22.39	2.51	56.19
Total nitrogen	2.26	0.99	0.92	1.08	0.18
Oxygen absorbed by aqueous extract	----	2.33	1.24	----	0.23
Quercitannic acid equivalent to O. absorbed	----	18.19	9.71	----	1.82

In conclusion, the author takes this opportunity to thank his highly esteemed instructor, Prof. Dr. Josef Moeller of Graz University, Austria, for kindly assistance in the early part of this investigation. The work was begun in Prof. Moeller's laboratory during the autumn of 1899, but after a year's interruption was finished at this Station.

Acknowledgment is also due Prof. E. Gale of Mangonia, Florida, who generously furnished material for study, and also Herr F. X. Matalony of Vienna, who skillfully reproduced on wood the author's drawings.

ART. XXX.—*Studies of Eocene Mammalia in the Marsh Collection, Peabody Museum*; by J. L. WORTMAN. With Plates I-IV.

[Continued from page 206.]

SUBORDER CREODONTA Cope.

In the first part of this paper, I have given the more important characters by means of which this group of the Carnivora is distinguished from the Carnassidentia. It now seems desirable to enter somewhat more fully into a discussion of these particulars, and I shall therefore consider some of the characters of less importance, from the point of view of classification. The first of these which it is necessary to emphasize as a broadly distinguishing feature is that the Carnassidents have been successful, and have left numerous modified descendants which constitute a large and important part of the living mammalian fauna in almost all regions of the globe; whereas the Creodonts failed, and have completely died out, without possibly the aquatic Pinnipedia represent them in the living Carnivore fauna.

In the organization of the skull, there are a number of characters that are more or less distinctive, among which may be mentioned the large lachrymal spreading out upon the face, as is invariably the case among the carnivorous Marsupials and a number of the Insectivora. This is true of *Mesonyx*, *Dromocyon*, *Harpagolestes*, *Sinopa*, *Proviverra*, *Limnocyon*, *Thereutherium* (?), and very probably also of *Oxyena* and *Patriofelis*. In some species, notably the Mesonychidæ, the nasals are broad posteriorly, as in the Marsupials, and almost exclude the frontals from contact with the maxillaries. The posterior border of the palate is terminated by a thickened ridge, recalling to a certain extent the structure of the marsupial palate. In the posterior part of the palate, moreover, there are very generally a large number of foramina of variable size, but usually minute, situated behind the posterior palatine canals, which undoubtedly represent the remains of the vacuities so common to the marsupial skull. In certain forms, especially *Sinopa*, and in some species of *Hyenodon*, as Scott has shown,* there is an additional foramen in the base of the skull, just in advance of the condyloid, which is also a conspicuous feature of the marsupial skull. The zygomatic arch, with its component bones, is heavy, and the malar usually extends well back toward the glenoid cavity. In the superior molars, if either border is elongated it is always the posterior,

* Jour. Acad. Nat. Sci., 1888, p. 178.

and if any of the molars and premolars are especially enlarged, it is never exclusively the fourth premolar above and the first molar below. The scaphoid, lunar, and centrale are very generally free; but according to Cope,* they are united in some French species of *Hyænodon* from the Miocene. In some forms, such as certain of the *Arctocyonidæ*,† there may also be union of the scaphoid and centrale, as in many carnivorous Marsupials, and the pollex and hallux may be more or less opposable. In some species, the ungual phalanges are relatively broad, flattened, and fissured at their ends, while in others they are laterally compressed, curved, and pointed.

If we now contrast these characters with those of the Carnassidentia, we observe that in them the lachrymal is never spread out on the side of the face, but is confined within the orbit.‡ The nasals are not especially broad posteriorly; the posterior edge of the palate is not thickened; the numerous posterior palatal foramina are absent; there is never a double condyloid foramen, and it is always the anterior border of the superior molars that is elongate, if either.§ If there is enlargement and specialization of any of the teeth it is always the fourth superior premolar above and the first true molar below. From the Upper Eocene stage onward, the scaphoid, lunar, and centrale are always united, and there is never union of scaphoid and centrale alone. The bony claws are always curved, compressed, and pointed.

Present evidence points to the fact that the two groups probably arose side by side from the Mesozoic Marsupials,|| although we do not know any true Carnassidents earlier than the Torrejon, while certain of the Creodonts come from the Puerco.

Quite recently, Matthew¶ has classified the Creodonta as follows:

* Tertiary Vertebrata, p. 256.

† See Matthew, Bull. Amer. Mus., Nat. Hist., Jan., 1901, p. 14.

‡ The only exception to this statement with which I am acquainted is found in the viverrine *Eupleres gondati*, from Madagascar, which otherwise resembles the Insectivores.

§ An apparent exception to this is found in *Palæonictis*, in which the posterior border of the first molar is slightly longer than the anterior.

|| I here use the term Marsupials in its larger sense, or as equivalent to the Metatheria of Huxley. It would appear to be more or less doubtful whether the existing Marsupials furnish a stage of embryonic development immediately antecedent to that of the appearance of a distinct allantoic placenta. Just how far they may have departed from their Mesozoic ancestors in this respect we shall never, perhaps, be able to ascertain, but there cannot be the slightest doubt of the fact that a preplacental stage existed, from which the placental had its origin. While it may not have been exactly like that seen in the living Marsupials, it must have, according to the very nature of the case, resembled it in a great many important particulars.

¶ Loc. cit., p. 7.

- "I. CREODONTA PRIMITIVA. No specialized carnassial; tritubercular upper and lower molars; shear rudimentary or absent. Claws unknown.
Oxyclenidæ. Includes some genera with Lemuroid affinities in the dentition.
- II. CREODONTA ADAPTIVA. Carnassial, when present, on p.⁴ and m._T. Claws, where known, of modern type and carried probably more or less free of the ground. Scapholunar-centrale early uniting (podials tending towards true Carnivore type).
 1. Post-carnassial teeth disappearing *Paleonictidæ*.
 2. Post-carnassial teeth becoming tubercular *Viverravidæ*.
 3. No carnassials; molars becoming flat-crowned; premolars disappearing *Arctocyoniidæ*.
- III. CREODONTA INADAPTIVA. Carnassial, when present, not on p.⁴ and m._T. Claws, where known, blunt, hoof-like, resting on the ground. No tendency of union of the carpals (podials tending toward Ungulate type).
 1. Carnassials m.¹/₂ shearing teeth *Oxyænidæ*.
 2. Carnassials m.²/₃ shearing teeth *Hyænodontidæ*.
 3. No carnassials; teeth with high, round, blunted cusps; upper molars tritubercular; lower molars premolariform *Mesonychidæ*."

This classification is of course based upon the older conceptions of the limitations of the group, and differs materially from that herein proposed. For example, the *Palæonictidæ* and *Viverravidæ* have been removed to the Carnassidentia, the reasons for which have been fully set forth on a preceding page. This leaves only the single family *Arctocyoniidæ* in Matthew's group "Creodonta Adaptiva." This family, as has already been suggested, stands much nearer to the carnivorous Marsupials in the organization of the feet than to any Carnassident. The union of the scaphoid and centrale, the marked tendency to opposability of both pollex and hallux, the character of the fibulo-astragalar articulation, as well as the compressed, curved, and pointed claws, are almost exactly paralleled in the case of the living Dasyures. Moreover, it is highly probable that this family will be found to be further characterized by the extra-orbital extension of the lachrymal and the double condylar foramen. In the light of these facts neither the genus nor the family can be regarded as having any very close affinities with the Carnassidentia.

In this connection, it is important to state that Cope, in his description* of the fragmentary skeletal material of *Clænodon ferox* at his disposal, compared it carefully with the carnivorous Marsupials *Didelphys*, *Sarcophilus*, and *Thylacynus*; he pointed out a number of similarities of structure to these forms

* Tertiary Vertebrata, 1884, p. 330.

and concluded that "its nearest living ally is the *Thylacynus cynocephalus* of Tasmania." In opposition to this view, Matthew observes*—"Clænodon has, however, no marsupial characters except such as may be considered an inheritance from a common stock, which gave rise to both Marsupials and Placentals. Its progressive characters are placental carnivore." Just how this latter author explains the remarkable resemblances of foot structure in the two groups, including the marked tendency towards opposability of pollex and hallux, or what constitutes the so-called progressive characters of which he speaks, other than these same marsupial characters, I am at a loss to imagine. In my judgment Cope's position rests upon very sound anatomical reasoning, the force of which is rendered all the more patent by these later discoveries.

As regards the third group, I am compelled to add that I find myself unable to accept the definition as accurate, or the grouping as natural. If by the term carnassial is meant the *most specialized* cutting teeth of the series, then the definition is fairly satisfactory, but the character would have been much better and more clearly expressed, had it been stated what teeth are sectorial. The character of the unguinal phalanges, and their supposed manner of articulation, I do not regard as of any very great value in the classification of the major divisions of this group, for the reason that within the limits of one of the families, at least, their structure ranges from the compressed, curved, and sharp-pointed variety, to the flattened, depressed, and fissured type.

The statement that the podials are tending toward an "Ungulate type" is such an extraordinary one, and is so at variance with the facts, especially as regards the Oxyænidæ and Hyænodontidæ, that I can hardly believe that the author intended it to apply to these families. It is true that the feet of the Mesonychidæ, in the later members, assumed a more or less "Ungulate type," because of a highly developed running habit, just as, among the living Carnassidents, the limbs of the modern Canidæ have taken on a similar structure from a like cause. But to suppose that there is even the faintest suggestion of anything "Ungulate" in the foot structure of such forms as *Sinopa*, *Limnocyon*, *Oxyæna*, *Patriofelis*, or *Hyænodon*, other than the fissured claws in the last three genera, is certainly quite beyond the facts.

The association, moreover, of the Mesonychidæ with the Oxyænidæ and Hyænodontidæ is not very apt, since in point of structure it is widely separated from these two families, and constitutes one of the most distinct and separate groups of

* Bull. Amer. Mus. Nat. Hist., 1901, p. 12.

the suborder thus far known. I define the five families as follows:

Oxyclænidae. No specialized carnassials; tritubercular upper and lower molars; shear rudimentary or absent (Matthew).

Genera: *Oxyclænus*, *Chriacus*, *Protochriacus*, *Deltatherium*, and *Tricentes*. All from Lower and Middle Eocene.

Arctocyonidae. No carnassials; molars flat-crowned; premolars becoming progressively reduced in size; scaphoid and centrale early united; hallux and pollex more or less opposable; claws compressed, curved, and pointed.

Genera: *Arctocyon*, *Clenodon*, and *Anacodon*. From Lower and Middle Eocene.

Mesonychidae. No carnassials; molars with characteristic, high, bluntly conical cusps, superior tritubercular, inferior becoming premolariform; claws depressed, little curved, and fissured; limbs in later forms becoming much modified in accordance with running habit.

Genera: *Triisodon*, *Goniacodon*, *Sarcothraustes*, *Dissacus*, *Pachycæna*, *Mesonyx*, *Dromocyon*, and *Harpagolestes*. From Lower, Middle, and Upper Eocene.

Oxyenidae. Pm.⁴ and M.^{1,2} carnassial, of which M.^{1,2} are largest and most specialized; claws, as far as known, depressed, little curved, and fissured.

Genera: *Oxyæna*, *Patriofelis*, *Limnocyon*, *Oxyænodon*, and *Thereutherium*. From Middle and Upper Eocene.

Hyænodontidae. Pm.⁴ and M.^{1,2,3} carnassial, of which M.^{2,3} are the most specialized, especially in the later types; claws depressed, little curved, and fissured; or compressed, curved, and pointed; in early types a double condyloid foramen as in Marsupials.

Genera: *Sinopa*, *Proviverra*, *Hyænodon*, *Pterodon*, *Quercytherium*, *Cynohyænodon*, *Pukeosinopa*, and *Didelphodus*. From Middle and Upper Eocene and Oligocene.

Family Mesonychidae Cope.

This family is represented at the very beginning of the Tertiary by the genus *Triisodon*, with three well-marked species from the Puerco of New Mexico. In the succeeding Torrejon beds of the same region, three generic modifications make their appearance; namely, *Sarcothraustes*, *Goniacodon*, and *Dissacus*. The first of these has been properly regarded as the direct descendant of *Triisodon*, while the last represents the beginning of the *Mesonyx* line of succession. The first three of these genera—*Triisodon*, *Sarcothraustes*, and *Goniacodon*—have been considered by Cope and Scott to represent a distinct family, *Triisodontidæ*, but I have shown* that their classification is probably best accomplished by placing

* Bull. Amer. Mus. Nat. Hist., June, 1899, p. 146.

them as a subfamily of the Mesonychidæ. The differences which distinguish them from the Mesonychinae are not great, and consist in the deep, heavy lower jaws, with powerful symphysis, together with the much wider, more typically tritubercular upper molars, as well as the more subequal size and normal arrangement of the cusps of the trigon of the lower molars.

While the Trisodont division became extinct at the close of the Torrejon, in *Dissacus* we have the beginning of the *Mesonyx* line, which continued through the whole of the Eocene, being represented in the several stages by a number of species and genera, and towards the close of its career, as we shall presently see, developed a limb structure almost equaling, if not actually surpassing, that of the modern dogs in point of specialization for a running habit. The connections between these two extremes are close, the interval being completely bridged by the Wasatch *Pachyæna*. In *Dissacus*, the feet are relatively short and stout; they are pentadactyle and the toes were spreading, a condition which was gradually modified into the four-toed, compressed, elongated feet of the cursorial *Mesonyx*. I define the known genera of the Mesonychinae as follows:

- I. Digits, 5-5; humerus with an entepicondylar foramen.
- a. Internal cusps of inferior molars distinct; posterior external cusps of superior molars smaller than anterior; $M. \frac{3}{3}$, $Pm. \frac{4}{4}$ --- *Dissacus*.
 - b. Internal cusps of inferior molars vestigial; external cusps of superior molars equal; $M. \frac{3}{3}$, $Pm. \frac{4}{4}$ ----- *Pachyæna*.
 - c. Internal cusps of inferior molars vestigial; external cusps of superior molars equal; $M. \frac{3}{3}$, $Pm. \frac{3}{4(1)}$ ----- *Harpagolestes*.
- II. Digits 4-4; humerus without entepicondylar foramen.
- a. $M. \frac{3}{3}$ ----- *Dromocyon*.
 - b. $M. \frac{2}{3}$ ----- *Mesonyx*.

Subfamily Mesonichinae.

Harpagolestes macrocephalus gen. et sp. nov.

The remains upon which this genus and species are founded consist of the greater portion of a skull, together with a complete humerus of the right side, a distal end of a femur, and a centrum of an axis, all belonging to one individual. With the exception of considerable vertical crushing, the anterior portion of the skull is well preserved, including most of the teeth. The posterior part of both mandibular rami are present, with

most of the teeth *in situ*. These remains indicate an animal somewhat larger than *Mesonyx uintensis* of the Uppermost Eocene stage, which has hitherto been considered the largest Carnivore of the Eocene. The skull exceeds that of a full-grown Grizzly Bear, but the body was not as large in proportion.

The principal generic characters have already been stated in the foregoing analytical table. Those which distinguish it most sharply from the contemporary *Dromocyon* and *Mesonyx* are seen in the reduced number of superior premolars and the presence of an entepicondylar foramen in the humerus. Additional characters of importance are: The absence of a supertrochlear foramen of the humerus, the lack of complete molariform structure of the fourth superior premolar, together with the absence of the third superior molar. I have provisionally placed this form in the section having five toes on each foot, largely on account of the unspecialized condition of the humerus, which resembles that of *Pachyaena* more closely than *Mesonyx* or *Dromocyon*. The foot structure is unknown, but we can readily believe that the toes were not so much reduced as in the more specialized genera.

The Skull. (Plate I.)—The muzzle appears to be proportionally longer and wider than that of either *Dromocyon* or *Mesonyx*. The nasals spread out posteriorly, as in these genera, leaving only a narrow contact between frontal and maxillary. This condition is associated with the large extra-orbital extent of the lachrymal, which is spread out upon the side of the face, as in all the Mesonychids. The orbit is relatively more posterior than in *Dromocyon* or *Mesonyx*, and the lachrymal canal is single, rather small, and placed within the rim of the orbit. The premaxillæ are of moderate size, articulating freely with the nasals above, but not extending backward to join the frontals; they terminate posteriorly just above the infraorbital foramen, which is relatively large and issues above the middle of the third premolar. The brain-case and posterior frontal region are not well preserved, but there is evidence of a distinct postorbital process and a high sagittal crest. The palate is long and rather narrow; the opening for the posterior nares is placed well behind the posterior termination of the tooth line, at the thickened terminal border of the hard palate. Behind this the nasal groove is narrow and not very deep, the opposite pterygoid plates approaching each other below in such a manner as to leave a rather narrow opening. This is similar to the arrangement seen in the skull of many species of *Hyænodon* and is particularly noticeable in *Mesonyx uintensis*, as figured by Osborn.* The incisive foramina, or anterior

* Bull. Amer. Mus. Nat. Hist., 1894. p. 80.

palatine fossa, is relatively small and situated somewhat in advance of the canine; posteriorly, opposite the interval between the fourth premolar and first molar, are seen the palatal openings of the rather large posterior palatine canals, and behind these occur numerous smaller openings of variable size, which, as in so many other cases among the Creodonts, undoubtedly represent the vacuities of the marsupial palate.

The zygomatics are strong and massive, with considerable outward arching. The malar extends well forward upon the face, furnishing the entire inferior boundary of the orbit, and upon the under side of the arch, at the point of junction with the maxillary, develops a prominent process which doubtless served for the attachment of one of the principal tendinous origins of the masseter muscle. It passes backward in the usual way into the zygomatic process of the squamosal, terminating at a considerable distance in advance of the glenoid cavity. This cavity is large and roomy, and is terminated in front and behind by strong anterior and posterior glenoid processes. There is a small, rugged, slightly inflated, otic bulla, developed apparently from the tympanic, as in *Dromocyon vorax*. The foramen ovale is situated much as in this species, and there is satisfactory evidence of the existence of both an alisphenoid canal and a large postparietal foramen. The posterior region of the skull is otherwise too much broken to admit of a more extended description, further than to add that the occiput was apparently of the same narrow, elevated, overhanging type as that of *Dromocyon vorax*.

The lower jaw is deep posteriorly, the coronoid is comparatively little elevated, and exhibits that characteristic backward shape common to all the members of the family. The masseteric fossa is broad and shallow and the angle is strongly inflected as in the Marsupials. The condyle is broad and heavy, and of a half-cylindrical pattern. The symphyseal region is not preserved.

Dentition.—The dental formula, as far as at present known, is as follows: $I. \frac{3}{1}$, $C. \frac{1}{1}$, $Pm. \frac{3}{4(2)}$, $M. \frac{2}{3}$. Of the superior series, the crowns of the incisors are not preserved, but judging from their alveoli, they were of the pattern and relations common to a large number of the Creodonts. They were arranged in a semicircle in the premaxillæ, the outer pair being considerably larger than the other two, and separated from the canine by a short diastema. The canine is large and powerful; it is sub-round on cross-section at the base of the crown, and is deeply implanted in the maxillæ; there were apparently no anterior or posterior cutting ridges developed. The first premolar is small, with a slightly hook-shaped crown, and is implanted by a single root close to the base of the canine, like the corre-

sponding tooth in the skull of certain species of *Ursus*. The second premolar has completely disappeared, a long diastema intervening between the first and third. The third premolar is implanted by two powerful roots; its crown is composed of a single, large, antero-median conical cusp, with a marked posterior swelling, which in the unworn condition may have borne a more or less distinct basal talon, or heel. The crown of the fourth premolar, like those of the succeeding molars, is much worn and does not display very clearly the arrangement of the cusps; it is supported by three roots, and, in the unworn condition, there were apparently two external and one internal cusps. Of the two external the anterior was evidently much the larger, so that the crown cannot be said to have been fully molariform. The cusps of the molars cannot be determined satisfactorily, but it may be assumed that the first molar had the typical three subequal cusps, and that the crown of the second was more or less degenerate. The crowns of the lower molars are also in a much worn condition; the third is, however, sufficiently unworn to show the simple premolariform arrangement of the cusps, a condition which without much doubt obtained in the teeth in advance. The incisors and anterior premolars of this series are wanting in the specimen.

The humerus, figure 44, is small in comparison with the size of the skull. This proportional disparity between the size of the head and body is true of quite a number of the Creodonts, but not of all of them, as will be shown later. The *caput* has a pyriform outline, well rounded in both directions, and overhangs the shaft posteriorly. The greater tuberosity is large and rises considerably above the level of the head. The

44



FIGURE 44.—Right humerus of *Harpagolestes macrocephalus* Wortman; front view; one-fourth natural size. (Type.)

tendinal impressions for the attachment of the *spinati* and *teres minor* are large, roughened, and very distinct, indicating unusual strength for these muscles. The bicipital groove is wide and is placed well upon the inner side of the bone. The lesser tuberosity is prominent, and there is a large rugose area for the insertion of the subscapular tendon. There is a power-

ful deltoid crest, which extends well down the shaft. As in all the later Mesonychids, the distal extremity has the appearance of being compressed from side to side, resulting from the decrease in size of the supinator ridge and internal condyle, in marked contrast with the broad extremity of this bone in the earlier forms. The internal condyle, while reduced, exhibits an entepicondylar foramen for the passage of the principal vessels and nerves to the forearm, although the bony bridge covering it is small. The condyle is considerably enlarged posteriorly and is separated from the inner edge of the trochlea below, by a deep notch. The anconeal and anticubital fossæ are deep, but there is no supertrochlear foramen. Of the articular surface the *capitellum* is distinct, wedge-shaped, and separated from the trochlear groove by a tolerably distinct ridge. The trochlear groove is wide and moderately deep; the inner edge is unusually prominent and extends considerably below the general level of the articulation.

With the exception of a distal end of a femur, which does not offer any characters of especial interest, no other limb bones are certainly known.

The principal measurements are as follows:

	mm.
Length of superior dental series from incisive border	197·5
Width between outer border of incisors	54·
Antero-posterior diameter of canine at base of crown	31·
Transverse diameter of canine at base of crown	23·
Length of canine including root	135·5
Length of molar and premolar series from posterior border of canine	138·5
Length of diastema between first and third premolars	29·
Length of true molars (antero-posterior)	44·5
Transverse diameter of first molar (posterior border)	26·
Transverse diameter of second molar	21·5
Length of palate from incisive border to posterior narial opening	222·5
Width of palate between the canines	39·5
Width of palate between last molars	65·
Length of humerus	275·
Transverse diameter of head	54·
Width (transverse) of distal end	67·5
Length of lower molar series	83·
Depth of lower jaw at last molar	85·5

The specimen is from the lower part of the Bridger Beds, near the mouth of Smith's Fork, and was found by R. E. Son.

Dromocyon vorax Marsh.

Dromocyon vorax Marsh. This Journal, vol. xii, July, 1876, p. 403.

The second genus of this subfamily to be considered is *Dromocyon*, and fortunately the remains upon which it was founded consist of a nearly complete skeleton of a single individual, in magnificent preservation. In his original description of this genus and species, Professor Marsh states: "A new and remarkable carnivorous mammal about the size of a large wolf is represented in the Yale Museum by a nearly complete skeleton. In the form of the skull, and general character of the jaws and teeth, the genus resembles *Hyenodon*. In the present specimen there were apparently but two lower incisors in each ramus. There are seven lower molar teeth, and the last lower molar is small. The top of the skull supported an enormous sagittal crest. The brain was small and convoluted. The lower jaws are long and slender, and the condyles low. The femur has a small third trochanter, and the astralagus a facet for the cuboid. There were four toes in front, and four behind."

This description, as will be seen from the analytical table given above, does not distinguish the genus sufficiently from *Mesonyx* or other members of the subfamily. Cope recognized two species of *Mesonyx* from the Bridger horizon, *M. obtusidens* and *M. lanius*.* The latter of these was originally described as a separate and distinct genus, *Synoplotherium*, which, however, was afterward abandoned as indistinguishable from *Mesonyx*. The type specimen of *M. lanius* consists of a portion of the skull, together with one fore foot more or less complete, and numerous fragmentary parts of the skeleton of a single individual, from the lower levels of the Washakie Basin.

Of this specimen, which is the only one thus far known, Cope,† in speaking of the incisor region of the lower jaw, says: "The most remarkable feature of the genus is seen in the inferior canines. These are very large teeth, and are directed immediately forwards, as in the cutting teeth of rodents. They work with their extremities against the retrorse crowns of the two external incisors above, and laterally against the superior canine. They are separated by a space about equal to the diameter of one of them. In this space I find no alveoli nor roots of teeth; the outer alveolar wall extends far beyond the inner. The latter terminates opposite the middle of the superior canine. It may be that there are no inferior incisors."

While the structure of the fore foot as well as other comparable parts of the skeleton of *Dromocyon vorax* agree very closely in size and other respects with the description and

* Tertiary Vertebrata, 1884, pp. 348, 362.

† Loc. cit., p. 359

figures of *M. lanius*, as given by Cope, there is no such arrangement of inferior canine and incisors as above described. It may possibly be that the condition of Cope's type of *M. lanius* is abnormal in this respect, and that *Dromocyon vorax* is the same as *M. lanius*; but until this is confirmed or disproved by additional specimens, I feel bound to regard the two forms as distinct. A further reason for such a course lies in the fact that the two specimens are from widely separated localities in different basins, *M. lanius* coming from the Washakie, and *Dromocyon* from the Bridger.

The Skull. (Plates II–IV.)—Like all members of the Mesonychidæ thus far known, the skull is large in proportion to the size of the body; its length is equivalent to that of $15\frac{1}{2}$ vertebræ counting from the first dorsal backward, or it is about one and one-half times the length of the femur. When compared with a large specimen of *Canis familiaris* (Bloodhound), the size of the two skeletons being about equal, the length of the skull is seen to be quite one-half greater. In this specimen of the dog, the length of the skull is equal to that of only 10 vertebræ counting from the first dorsal backward, or is just about equal to that of the femur.

The muzzle is of moderate length and height, slightly constricted behind the canines, and obliquely truncated in front. The anterior narial opening looks forward and a little upward. The premaxillæ exhibit the form and relations usual among the Carnivora; they articulate freely with the nasals above, but do not send up a process to join the frontals behind, as in many Carnivores. The nasals are broad posteriorly, and in connection with the lachrymals almost exclude contact between frontals and maxillæ, as in certain carnivorous Marsupials, notably *Sarcophilus* and *Didelphys*. As in these latter forms, owing to the large size of the lachrymals, the maxillæ are excluded from any share in the boundary of the orbit, whereas in all the Carnassidents, with the exception of *Eupleres*, the posterior edge of the maxillary reaches the anterior rim of the orbit. The infraorbital foramen is large, and has its usual position above the posterior border of the third premolar. The orbit is relatively small, as in *Sarcophilus* and the opossum, in marked contrast with its large size in the great majority of the Carnassidents: its anterior border lies above, and coincides with, the anterior edge of the second molar. As already mentioned, the lachrymal is large and spreads out upon the face to a considerable extent; it carries a very prominent lachrymal tubercle, as in many of the Marsupials, but the lachrymal canal is simple and opens within the rim of the orbit, as in the Carnassidents. There are well-developed postorbital processes of the frontals, and corresponding though less distinct processes

on the malars, marking the posterior boundaries of the orbital cavities below. The zygomatic arches are rather broad and heavy; they are widest a short distance in advance of the glenoid cavity and apparently lack the graceful outward curving so common to the carnassident skull, although it is difficult to say just how much of this appearance is due to post-mortem pressure. In their present form they resemble those of the opossum. The malar has a considerable extension upon the side of the face, and displays a prominent median ridge, which is continued forward to the infraorbital foramen. On the under surface of the arch, at the point of junction of the malar with the maxillary, there is a prominent process for the tendinous origin of the most anterior fibers of the masseter. This process is apparently wanting in the carnassident skull, but is large and prominent in that of the Opossum, *Dasyure*, and to a less extent in *Sarcophilus*.

The postorbital constriction is marked, and as in the Marsupials, the brain cavity is relatively very small. Just posterior to this constriction the diverging branches of the postorbitals unite to form an enormous sagittal crest, which passes back to the high, narrow, overhanging occiput. At the base of the crest, opposite the external auditory meatus, is seen the superficial opening of the unusually large postparietal canal,—a venous foramen which served as a conduit for the venous blood passing to the lateral sinus.

The posterior view of the cranium, Plate III, shows the occiput to be very high and narrow, and at the same time, extending considerably beyond and overhanging the condyles; it exhibits a very rugose surface for the attachment of the nuchal muscles, and near the middle portion there is a localized roughened area for the origin of the nuchal ligament. The lambdoidal crest is broad and laminate above, less distinct and more spreading below, and passes around upon the squamosal in the usual manner, to become continuous with the posterior root of the zygoma. The condyles are large, protuberant, and divergent, and the foramen magnum looks backward and downward. The mastoid has quite an extensive exposure upon the postero-lateral part of the occipital surface, but no greater than that of the opossum or dog; it becomes prominent laterally and forms a moderately large mastoid protuberance, similar to that of the bears and the arctoid Carnassidents in general. Upon the posterior surface of this process is seen the external opening of the large stylomastoid foramen, and in front of and a little below this is a rather deep recess, which probably marks the point of attachment of the hyoid arch, although there is no plug-like tympanohyal present. This posterior position of the stylomastoid foramen appears to be peculiar to certain of the

Creodonts; it has a similar position in *Oxyæna* and *Patriofelis*, and probably also in *Hyænodon*, but of this latter genus I cannot speak with certainty. In the marsupial skull its opening is upon the under and more or less anterior surface of the bone, as it is in Carnassidents. The paroccipital process is rather small and has more of a backward and outward than downward direction. Between the mastoid and exoccipital there is a deep fissure, which at its upper extremity is pierced by a foramen, as in the dog.

Upon the under surface of the skull, Plate IV, the basioccipital is rather narrow and the point at which it articulates with the basisphenoid is much roughened for the attachment of the *recti capiti* muscles. Immediately in advance of the condyles is seen the single pair of large condyloid foramina. The tympanic bullæ are of moderate size, rugose, and apparently developed exclusively from the tympanic, without inflation of any part of the alisphenoid, as in the Marsupials. The external auditory meatus is rather long and tubular and opens between the mastoid and postglenoid. At the postero-internal angle of the bulla is placed the irregular opening of the foramen lacerum posterius, which is probably also the point of entrance of the internal carotid artery, although I am unable to discover any very distinct canal which answers to this foramen in the carnassident skull. At the anterior extremity of the bulla are the openings of the foramen lacerum medius and the eustachian tube, and immediately in advance of these, on the prominent ridge leading forward from the internal edge of the glenoid cavity, are situated the foramen ovale and the posterior opening of the alisphenoid canal.

One of the most conspicuous features of the base of the skull is the very large size and low position of the glenoid fossæ; they are supported upon unusually thick, heavy processes of the squamosals, which project much below the level of the base of the skull. The cavity is relatively deep, and is spout-like and transverse, the depth being considerably augmented by the unusually prominent anterior and posterior glenoid processes. The pterygoids are broad, thin, wing-like, and project considerably below the base of the skull and the level of the palate. The postnarial groove is continued well forward; it is deep, rather narrow, but there is apparently no tendency for its palatine boundaries to arch it over below, as in *Hyænodon*. The optic foramina are distinct from each other and occupy their usual position in the carnivorous skull, just in advance of the sphenoidal fissure. In front of and a little above the optic, near the junction of the frontal with the orbitosphenoid, is a small but distinct opening which corresponds to the anterior ethmoidal foramen of human anatomy, for the passage of the

nasal nerve. The anterior sphenoidal fissure and foramen rotundum are apparently distinct, although a slight crushing of this region of the skull renders this somewhat uncertain; they seem to open externally in a circular depression common to these two and the anterior opening of the alisphenoid canal.

The palate is rather long and narrow. The anterior palatine fossæ have a position well forward and are more or less slit-like. The posterior palatine canals are of moderate size and are placed opposite the fourth premolar, which nearly coincides with the anterior limit of the palatine bones. Posterior to these are some eight or ten minute openings which in all probability are vestiges of the vacuities of the marsupial palate. The posterior edge of the palate is considerably thickened, and between the posterior extremity of the maxillary and the palatine is a deep groove, the function of which is not very clear.

The lower jaw of the individual under consideration is of unusual pathological interest, as showing, among these ancient animals, the result of healing of a fracture. During life the horizontal ramus of the left side had been broken near the middle portion, opposite the second molar, and had completely healed without any apparent shortening. The posterior portion had, nevertheless, been displaced upward, and a large exostosis formed upon the outside, involving at the same time the inferior border of the horizontal ramus.

The right ramus is, however, normal and may be described as long and moderately slender. The symphysis is strong and extends to beneath the anterior border of the third premolar. Anteriorly, upon the side of the horizontal portion, are two mental foramina, the larger of which is situated beneath the first premolar and the smaller beneath the anterior portion of the third premolar. The coronoid is of moderate height and displays the characteristic backward slope, peculiar, as far as I am aware, to all members of the subfamily; it lacks the usual high falcate pattern so common to the Carnivora. The masseteric fossa is broad and shallow and does not exhibit the strong ridges for muscular attachment of the more typical biters. The condyles are heavy, of half-cylindrical pattern, and supported upon rather long, stout necks. The angle is prominent and considerably inflected, as in the Marsupials. Indeed, the posterior region of the mandible exhibits so many striking peculiarities that, in the absence of other parts of the skeleton, it would be quite sufficient to distinguish the subfamily without difficulty.

Dentition.—The teeth are in such a worn condition that they furnish very unsatisfactory information of their structure. They were, however, so nearly like those of *Mesonyx obtusidens*,

fully described by Scott,* that if one can judge from appearances, there will be little difficulty in supplying the deficiencies. The formula of the specimen is $I. \frac{3}{1}$, $C. \frac{1}{1}$, $Pm. \frac{4}{1}$, $M. \frac{3}{3}$, but there is reason to suspect that the senile condition of the individual may be responsible for the presence of so few incisors in the lower jaw. In the superior series there are three incisors indicated upon each side, of which but a single one remains in place in the jaw. The alveoli for the others are shallow and apparently partially closed up, which would indicate that they were to a certain degree caducous. They were, however, implanted in the jaw in the ordinary way, and were very little, if at all, procumbent. The canines are indicated by their large elliptical alveoli, which penetrate deeply into the maxillæ. The first premolar is single rooted and follows immediately behind the canine without diastema. The second is two-rooted and had a crown in the unworn condition, composed evidently of an anterior conical and a posterior basal cusp. The third is likewise two-rooted, with a similarly constituted crown. The fourth is three-rooted, and was therefore, a three-cusped tooth of which there were apparently two subequal external and one internal, being thus fully molariform. The two succeeding molars are of the same size, and, as nearly as can be determined, their crowns have the same composition. The last molar was considerably reduced, but the structure of its crown cannot be made out.

In the inferior series there is but a single pair of incisors, but, as already remarked, the advanced age of the individual at the time of its death may have had something to do with this condition. Such a view is rendered all the more probable by the fact that the tooth pertaining to the right side, which still remains in place, lies close to the canine, while its fellow of the opposite side, or at least what appears to be such, is implanted almost directly in the middle of the alveolar border. The canines, of which the right remains *in situ*, are of large size and upright position. The crown of the one preserved is badly worn, and, in consequence, is very blunt and rounded. The wear resulting from contact with the corresponding tooth in the upper jaw is postero-lateral, and hence normal, so that it can be definitely stated that they had no such position as Cope has described in *Mesonyx lanivus*. With the exception of the single-rooted, simple-cusped first premolar, all the succeeding teeth have the bicuspidate premolariform structure of *Mesonyx*. The last molar is notably smaller than the rest and is implanted well up on the sloping border of the coronoid. This gives a peculiar and characteristic curved line of implantation.

* Jour. Acad. Nat. Sci., Phila.

[To be continued.]

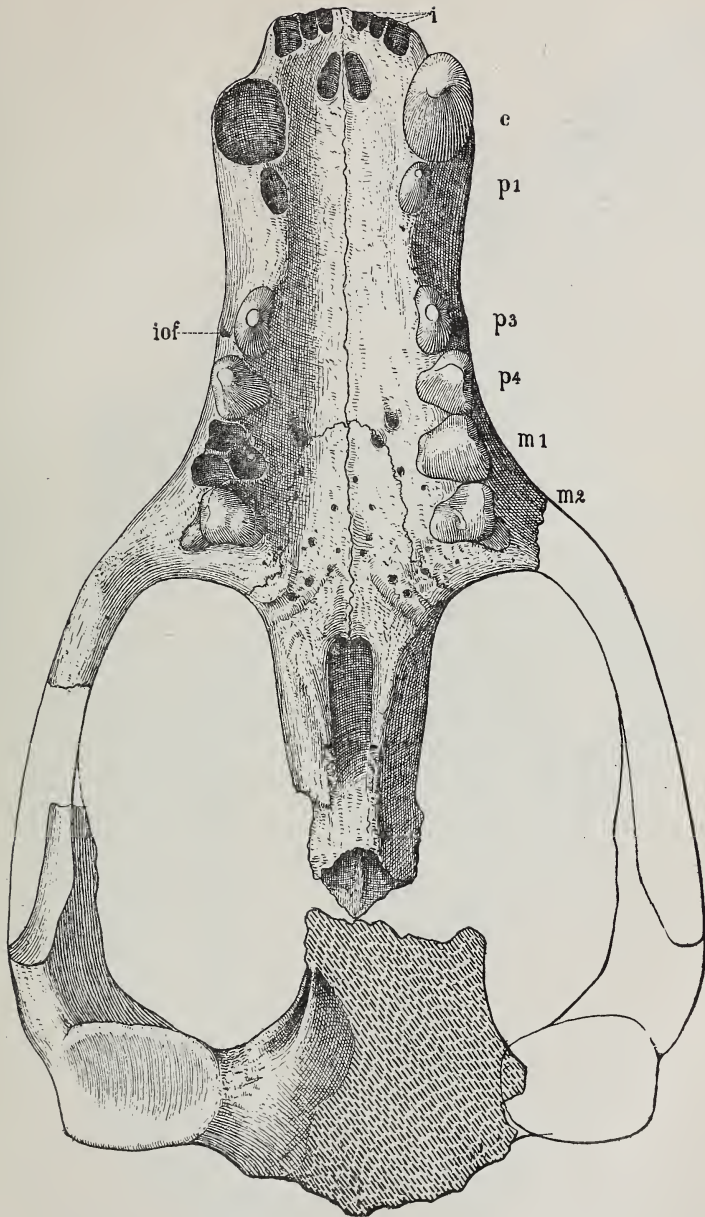

EXPLANATION OF PLATE I.

Skull of *Harpagolestes macrocephalus* Wortman; under view; three-eighths natural size. (Type.)
iof, infraorbital foramen.

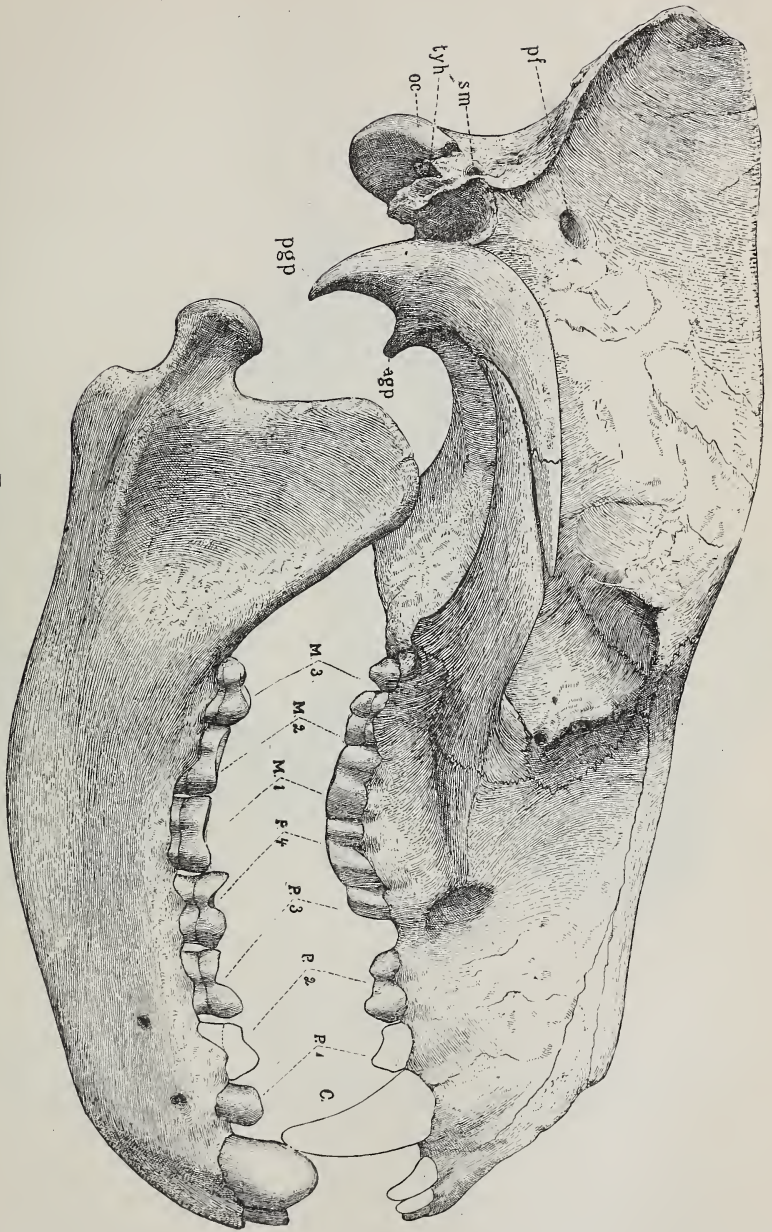

EXPLANATION OF PLATE II.

Side view of the skull of *Dromocyon torax* Marsh; one-half natural size. (Type.)
pf, parietal foramen; *sm*, stylomastoid foramen; *tyh*, point of articulation of the hyoid arch; *oc*, occipital condyle;
pgp, postglenoid process; *agp*, anterior glenoid process.

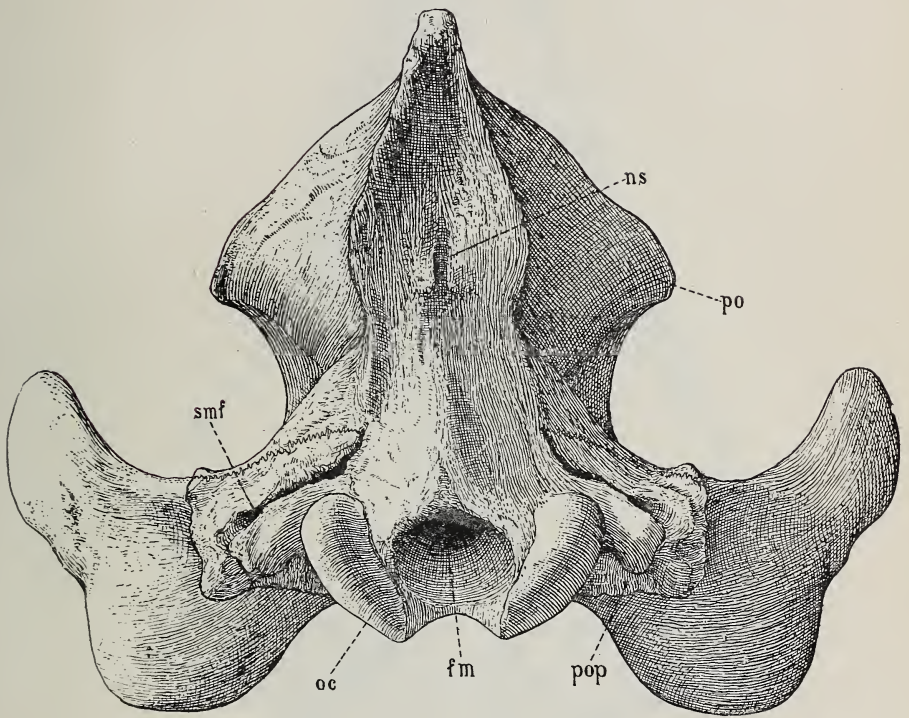

EXPLANATION OF PLATE III.

Skull of *Dromocyon vorax* Marsh; posterior view; three-fourths natural size. (Type.)

ns, nuchal spine; *po*, postorbital process; *pop*, paroccipital process; *fm*, foramen magnum; *oc*, occipital condyle; *smf*, stylomastoid foramen.

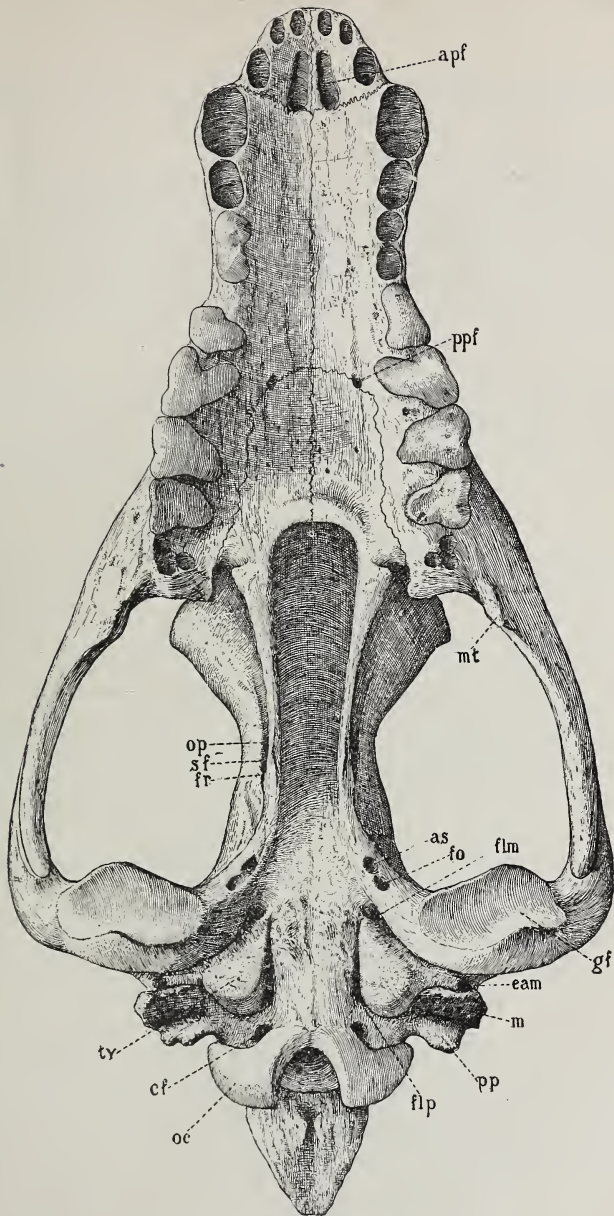

EXPLANATION OF PLATE IV.

Under view of the skull of *Dromocyon vorax* Marsh; one-half natural size. (Type.)

apf, anterior palatine foramen; *ppf*, posterior palatine foramen; *mt*, masticatory tubercle; *as*, alisphenoid canal; *fo*, foramen ovale; *flm*, foramen lacerum medius; *gf*, glenoid fossa; *eam*, external auditory meatus; *m*, mastoid; *pp*, paroccipital process; *flp*, foramen lacerum posterius; *oc*, occipital condyle; *cf*, condyloid foramen; *ty*, tympanic; *fr*, foramen rotundum; *sf*, sphenoidal fissure; *op*, optic foramen.

ART. XXXI.—*A new Crinoid from the Hamilton of Charlestown, Indiana*; by ELVIRA WOOD. With Plate V.

THE following paper was prepared in the laboratory of the Geological Department of the Massachusetts Institute of Technology: the specimen having been furnished for study through the courtesy of that institution. I take pleasure also in expressing my indebtedness to Prof. William H. Niles, head of the Geological Department, for the opportunity thus offered.

The specimen which serves as the type of the species described below, although deprived of the free arms and the column, is exceptionally well preserved, showing the more delicate structural features of the test. It is now in the collection of the Massachusetts Institute of Technology.

Gennæocrinus carinatus, sp. nov.

Calyx sub-globose. Arm regions prominent with deep furrows between them. Surface ornamented by delicate, sharply elevated carinæ and acute spines.

Basals three, pentagonal. The five hexagonal radials followed by 2×5 costals. First and second costals slightly, if at all, smaller than the radials. Distichals 1×10 . Of the primary palmars immediately following the distichals, that nearest the median line of the ray is an axillary plate bearing 3×20 secondary palmars; the outer is followed by two additional primary palmars, making 1×10 on the inner, and 3×10 on the outer side of the ray, or forty primary palmars in all. Interpalmars three, following one another in vertical succession. The third, or most distal, primary and secondary palmar in each row gives rise to an arm making six arm bases in each ray. The free arms are not preserved. First interbrachial plate followed by two in the second and three in the third row. Plates of the fourth row are variable in number. The succeeding plates merge into those of the tegmen.

The heptagonal primary anal of the posterior area is succeeded by three plates and these by four with a minute triangular plate intercalated between the two rows. Beyond this the plates are irregular in shape and difficult to distinguish, but there are probably five plates in the fourth and three in the fifth row, as represented in the diagram (fig. 1).

Tegmen moderately elevated, made up of small irregularly arranged plates. Ambulacral regions convex and separated by deep sulci extending half way to the summit of the tegmen. Just in front of the arms in line with the center of the ray is a strong spine 3 to 4^{mm} long. Immediately surrounding this

spine is a variable number of plates which bear low spines or nodes. Other plates of the tegmen appear to have been smooth. Anus located half way between the summit and the periphery, its plates not preserved.

Base of the calyx flat, a feature due to a thickening of the basals. This thickening extends over about two-thirds of the surface of each basal and is produced in a thin rim whose margin is parallel with that of the plate.

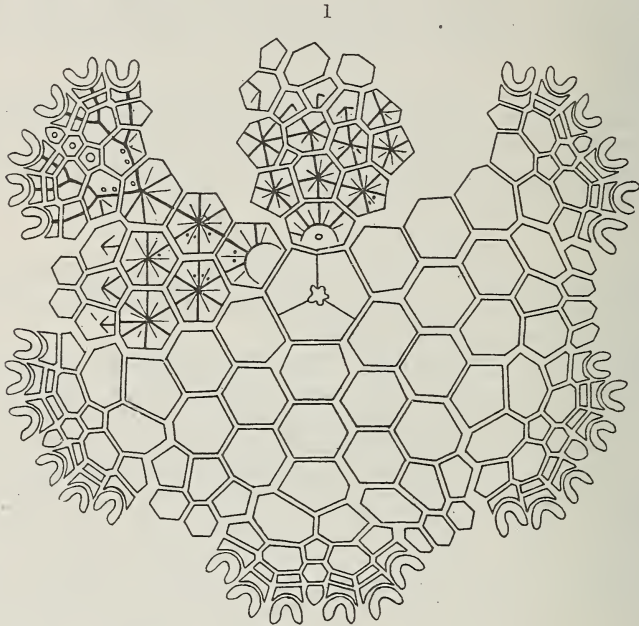

Diagram to show arrangement of calyx plates of *Genneocrinus carinatus*, sp. nov.

The lower half of each radial and the primary anal plate are ornamented by a projecting crescentic ridge thickened at the center and dying out or terminated by a spine at the sides. From the outer curve of this ridge carinæ pass to the upper sides and angles of the radial, where they meet similar carinæ of the higher brachials. The brachials and interbrachials bear strong carinæ which pass from the center to each side of the plate, and others, less prominent, directed toward but not reaching the angles.

Column circular, occupying one-half the area of the basals. Axial canal pentalobate and having a diameter one-third that of the column.

Observations.—This species is remarkable for its elaborate and delicate surface ornamentation, the thin carinæ rising at right angles to the surface and sometimes a millimeter or more in height.

The whorl of crescentic ridges on the radials when viewed from below bears some resemblance to a six-petaled flower. Each of three alternate petals has a small erect spine at the center.

The carina following the median line of the ray and its branches is stronger than the others and increases in prominence from the radials to the arm bases. This carina is straight to a point above the middle of the second costal, where it divides, each branch crossing a distichal and branching again below the upper angle of the plate. A third branching takes place on the inner primary palmar.

Spines are an important feature of the surface ornamentation. In addition to those already mentioned there are often minute spines in the angle formed by the finer and coarser carinae of the brachials and interbrachials. These are sometimes elongated, showing a tendency to form a new carina in this position. The second costal bears a very small spine in the angle formed by the branching of the strong carina, and two similar spines are present on the inner side of the distichal below the branching and in line with the straight portion of the carina. Three much larger spines, decreasing in size upward, are present on the interpalmars, one at the center of each plate.

The upper plates of the calyx are somewhat variable in shape. The second costals of the postero-lateral rays are heptagonal, those of the antero-lateral rays pentagonal and the anterior second costal is hexagonal, having three edges on one side, above the base, and two on the other; that is, one represents the heptagonal and the other the pentagonal type of plate. The distichals also vary in shape in the different rays. Those resting upon heptagonal costals have six and those on pentagonal costals seven sides. The distichal on one side of the anterior ray is thus heptagonal and that on the other side hexagonal, corresponding with the irregularity of the adjacent costal. The primary palmars resting upon the distichals are heptagonal on the inner and pentagonal on the outer side of the ray. The first interpalmar is an inverted pentagonal plate, the second hexagonal and the third obscurely pentagonal.

The first interbrachial is in each case regularly hexagonal, but the interbrachials of the second row are six or seven-sided according to the heptagonal or pentagonal shape of the adjoining second costal. The middle plate of the third row is hexagonal, wider at the lower than at the upper end. The other two plates of this row are hexagonal when the nearest distichal has the same number of sides and five-sided when the latter is a heptagonal plate.

The plates of the posterior area are irregular in shape and have five, six, or seven sides. Of the three plates resting upon the primary anal two are hexagonal and one pentagonal.

The plates of the tegmen do not vary greatly in size, the orals being only slightly larger than the others.

Formation and locality.—This species is found in limestones of the Hamilton Group at Charlestown, Indiana.

The species here described is closely related to *Actinocrinus* (*Gennæocrinus*) *cornigerus* Lyon and Casseday, but it differs from the latter in the presence of three instead of two interpalmar, the absence of a central spine on the tegmen and of crescentic ridges on the radials. According to the original description of *G. cornigerus* the plates of the posterior area resemble those of the Actinocrinidæ, that is one hexagonal primary anal followed by two plates; but this species is regarded by Wachsmuth and Springer as synonymous with *G. kentuckiensis*, in which the primary anal is heptagonal and bears three plates as in *G. carinatus*. *G. kentuckiensis* differs from the latter species in the number of distichals which is 2×10 instead of 1×10 , and in the arrangement of the palmar and interpalmar the axillary distichals supporting 2×4 palmar in each ray, and the three interpalmar being in two rows instead of one. From both *G. kentuckiensis* and *G. eucharis* the present species differs in the nearly equal size of second costals and radials, in the number and arrangement of the higher plates of the posterior area, and in several other important respects.

Actinocrinus asper Lyon bears an angular ridge on the lower portion of the radials which under favorable conditions of preservation might resemble the petal-like ornamentation of the radials in *Gennæocrinus carinatus*, but the basal plates are not thickened as in the latter species, the costals are very small in comparison with the radials, and each plate of the tegmen bears a strong node.

Gennæocrinus carinatus appears, therefore, to possess an association of well marked and peculiar features which entitle it to be considered a distinct species.

Geological Department,
Massachusetts Institute of Technology.

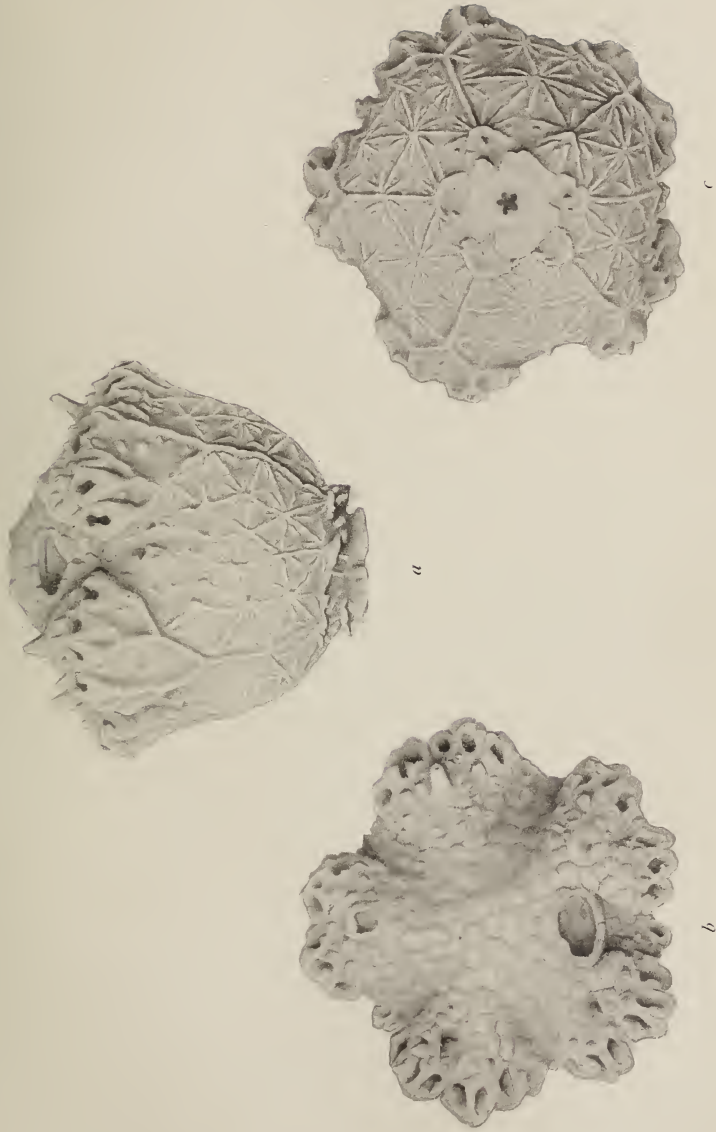

THE HELIOTYPE PRINTING CO., BOSTON.

GENNAEOCRINUS CARINATUS.

a POSTERIOR SIDE. *b* VENTRAL DISK. *c* DORSAL VIEW.

ELVIRA WOOD DEL.

ART. XXXII.—*On the Estimation of Cæsium and Rubidium as the Acid Sulphates, and of Potassium and Sodium as the Pyrosulphates*; by PHILIP E. BROWNING.

[Contributions from the Kent Chemical Laboratory of Yale University—CII.]

BUNSEN* is authority for the statement that the acid sulphate of rubidium does not lose sulphuric acid at a heat approaching redness. It is stated† in the literature that the acid sulphates of cæsium and rubidium when subjected to a low red heat pass into the form of the pyrosulphates. R. Weber‡ found that by treating the dry sulphates of potassium, cæsium, rubidium and thallium with sulphuric anhydride in a closed tube and heating on a water bath two layers separated. In the lower layer he obtained crystalline bodies which proved to have the constitution $R_2O \cdot 8SO_3$. On strong heating he obtained from these substances bodies of the form $R_2O \cdot 2SO_3$ and finally $R_2O \cdot SO_3$. He also notes that in the case of the cæsium salt the removal of the excess of sulphuric anhydride was attended with greater difficulty.

Baum§ states that the pyrosulphates of the alkalies may be obtained by heating the acid sulphates under atmospheric pressure at low redness, or under diminished pressure at a temperature between 260–320° C.

In a recent paper|| from this laboratory I have shown that thallium may be estimated as the acid sulphate by evaporating a thallos salt in solution with an excess of sulphuric acid and bringing the residue to a constant weight at a temperature of about 250° C. The similarity which thallium bears in some of its combinations to the alkaline metals suggested the study of the sulphates of these elements under the same general conditions of procedure.

My first experiments were made with a pure cæsium salt as follows: A weighed amount of the nitrate was placed in a previously weighed platinum crucible and treated with an excess of sulphuric acid. The crucible was then placed upon a steam bath until the water and nitric acid were largely expelled and then removed to a radiator, consisting of a porcelain crucible fitted with a pipe-stem triangle so arranged that the bottom of the platinum crucible would be about midway between the top and bottom of the porcelain crucible. This improvised radiator was set in an iron ring and a thermometer placed so that the mercury bulb would be on a level with the

* Ann. Chem. (Liebig), cxix, 110.

† Graham. Otto Lehrbuch d. Chem., iii, 278, 269.

‡ Ber. Dtsch. Chem. Ges., xvii, 2497.

§ Ber. Dtsch. Chem. Ges., xx, 752.

|| This Journal, ix, 137, 1900.

bottom and close to the side of the platinum crucible. An ordinary Bunsen burner served as the source of heat and the temperature was kept so far as possible between 250° C. and 270° C. After the fuming attending the removal of the large excess of sulphuric acid ceased, the crucible and contents were removed to a desiccator, and after being allowed to cool, weighed. This process of heating was continued for half-hour periods until the weights were constant. The results shown in Table I were obtained by this method of treatment. In experiments (1), (4) and (9) it will be noticed that the weights were constant somewhat above the conditions of the acid sulphate, a fact which would go to show a tendency on the part of the cæsium salt to hold an excess of sulphuric acid over the amount necessary to form the ordinary acid sulphate. The results show that by regulating the heat at a temperature

TABLE I.

	CsNO ₃ taken. grm.	CsHSO ₄ calcu- lated. grm.	1st constant weight. grm.	2d constant weight. grm.	Error on CsHSO ₄ . grm.	Cs ₂ SO ₄ calcu- lated. grm.	Cs ₂ SO ₄ found. grm.	Error on Cs ₂ SO ₄ . grm.
1	0·1706	0·2013	0·2054	0·2020	0·0007 +			
2	0·1706	0·2013	0·2010		0·0003 —			
3	0·1032	0·1217	0·1201		0·0016 —			
4	0·1032	0·1217	0·1252	0·1222	0·0005 +	0·0961	0·0948	0·0013 —
5	0·1218	0·1437	0·1458		0·0021 +	0·1130	0·1118	0·00 —
6	0·1214	0·1435	0·1430		0·0005 —			
7	0·1214	0·1435	0·1422		0·0013 —			
8	0·1150	0·1356	0·1330		0·0026 —			
9	0·1056	0·1245	0·1272	0·1248	0·0003 +			
10	0·1056	0·1245	0·1252		0·0007 +			

between 250° C. and 270° C. cæsium may be brought with a fair degree of certainty to the condition of the acid sulphate. As a check upon the results the acid sulphate was, in a few cases, treated with a little ammonium hydroxide, the excess of this was removed upon a steam bath and the neutral sulphate was obtained by ignition at a red heat to a constant weight. These determinations agreed fairly well with the theory.

The same procedure was followed with rubidium, a pure rubidium chloride having been chosen as the starting point. The results are given in Table II. No tendency was observed on the part of this element to hold sulphuric acid in excess of the amount necessary for the formation of the acid sulphate. When the same method of treatment was applied to the sodium and potassium salts, pure chlorides being used as the starting point, a somewhat different result was obtained, in that the weight of the final product appeared to indicate the formation of the pyrosulphate.

The results given in Tables III and IV, in which the sodium and potassium salts are calculated as pyrosulphates, are sufficiently satisfactory for purposes of quantitative estimation.

As in the case of the caesium and rubidium salts, a number of determinations as the neutral sulphates were made by ignition of the sodium and potassium pyrosulphates with results which are recorded. In Table V two determinations are recorded, in one of which the caesium and rubidium salts were treated together, and in the other the sodium and potassium salts. An application of this same general method

TABLE II.

	RbCl taken. gram.	RbHSO ₄ calcu- lated. gram.	RbHSO ₄ found. gram.	Error. gram.	Rb ₂ SO ₄ calcu- lated. gram.	Rb ₂ SO ₄ found. gram.	Error. gram.
1	0.1252	0.1889	0.1878	0.0011—			
2	0.1212	0.1829	0.1840	0.0011+	0.1460	0.1460	0.0000±
3	0.1230	0.1856	0.1850	0.0006—			
4	0.1230	0.1856	0.1858	0.0002+	0.1357	0.1350	0.0007—
5	0.1610	0.2430	0.2416	0.0014—	0.1777	0.1772	0.0005—
6	0.1360	0.2052	0.2032	0.0020—	0.1501	0.1490	0.0011—

TABLE III.

	KCl taken. gram.	K ₂ S ₂ O ₇ calcu- lated. gram.	K ₂ S ₂ O ₇ found. gram.	Error. gram.	K ₂ SO ₄ calcu- lated. gram.	K ₂ SO ₄ found. gram.	Error. gram.
1	0.2172	0.3704	0.3698	0.0006—			
2	0.1766	0.2909	0.2886	0.0023—	0.1993	0.1972	0.0021—
3	0.1192	0.2032	0.2022	0.0010—	0.1393	0.1381	0.0012—
4	0.1074	0.1830	0.1823	0.0007—			
5	0.1096	0.1868	0.1860	0.0008—			

to a lithium salt gave no evidence of the existence of a stable acid sulphate or pyrosulphate. The results may be summed up as follows: Caesium and rubidium salts of volatile acids when treated with sulphuric acid in excess and brought to a constant weight at a temperature between 250° C. and 270° C. form acid salts of the type RHSO₄ and the neutral salts of the type R₂SO₄ on ignition. Some tendency of the caesium salt to hold more sulphuric acid than corresponds to the formation of the acid sulphate RHSO₄ was apparent at temperatures between 250° C. and 270° C., but upon raising the temperatures above 300° C. the loss was excessive and showed a tendency on the part of the acid sulphate, at this temperature, to pass toward the condition of the pyrosulphate. Sodium and potassium salts when heated under the conditions described give pyrosulphates of the type R₂S₂O₇, which on ignition go into the neutral

sulphates of the form R_2SO_4 . Lithium gives neither salts of the type $RHSO_4$ nor of the type $R_2S_2O_7$ under the conditions of these experiments.

TABLE IV.

	NaCl taken. grm.	$Na_2S_2O_7$ calcu- lated. grm.	$Na_2S_2O_7$ found. grm.	Error. grm.	Na_2SO_4 calcu- lated. grm.	Na_2SO_4 found. grm.	Error. grm.
1	0·1042	0·1978	0·1972	0·0006—	0·1236	0·1254	0·0012—
2	0·1028	0·1952	0·1952	0·0000			
3	0·1093	0·2075	0·2065	0·0010—	0·1328	0·1320	0·0008—
4	0·1402	0·2662	0·2651	0·0011—	0·1703	0·1696	0·0007—

TABLE V.

	RbCl + CsNO ₃ taken. grm.	RbHSO ₄ + CsHSO ₄ calcu- lated. grm.	RbHSO ₄ + CsHSO ₄ found. grm.	Error. grm.	Rb ₂ SO ₄ + Cs ₂ SO ₄ calcu- lated. grm.	Rb ₂ SO ₄ + Cs ₂ SO ₄ found. grm.	Error. grm.
RbCl	0·1428						
(1) CsNO ₃	0·1264	0·3646	0·3666	0·0020 +	0·2749	0·2752	0·0003 +
	NaCl + KCl taken. grm.	$Na_2S_2O_7$ + $K_2S_2O_7$ calcu- lated. grm.	$Na_2S_2O_7$ + $K_2S_2O_7$ found. grm.	Error. grm.	Na_2SO_4 + K_2SO_4 calcu- lated. grm.	Na_2SO_4 + K_2SO_4 found. grm.	Error. grm.
(2) NaCl	0·1233						
KCl	0·1340	0·4627	0·4630	0·0003 +	0·3062	0·3040	0·0022—

March, 1901.

ART. XXXIII.—*Time Values of Provincial Carboniferous Terranes*; by CHARLES R. KEYES.

THERE have recently* been discussed at length certain remarkable features relating to the development of the Carboniferous rocks in the province of the Mississippi valley. The enormous thickness of the Carboniferous of the region—probably upwards of 25,000 feet—and the nicety with which it is separable into serial and minor subdivisions tend to make the general geological section of the Continental Interior basin the standard one for America.

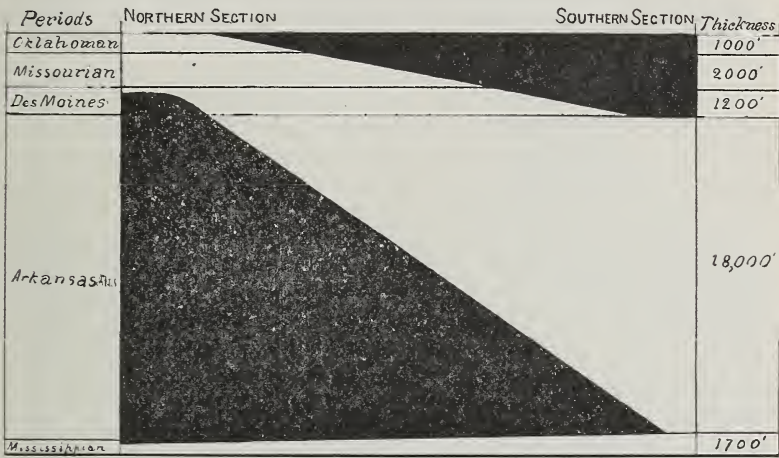

FIG. 1.—Relative Formational Development of the Carboniferous.

In describing the various peculiarities of the formations only the stratigraphical relations and features were considered. The importance attached to the marked inequalities in the development of the five series recognized which was made such a prominent factor and the absence of all reference to the relations of the several series to the time standard, appears to have led to the inference that the time ratios were to be regarded as approximately proportional. It was not the intent to unduly emphasize the stratigraphical disparities at the expense of the time representatives. The latter, for reasons not necessary to specify in detail here, were simply thought to be phases of the subject not to be considered in the article mentioned.

* Bull. Geol. Soc. America, vol. xii, 1901, pp. 173-196.

The stratigraphical features considered are summed up in the diagram above. It represents a meridional ideal section across the Carboniferous basin of the Western Interior region. The north and south ends are drawn to scale. The white represents the relative formation! development; and the black the portions now missing.

The very unequal development of the several series has given rise to a tendency to misconstrue the taxonomic ranks of the formations. For example, the Des Moines series has been sometimes given a rank subordinate to that of series; while in the case of the Oklahoman the suggestion has been made to have its rank that of a system.

If the stratigraphical values of the series be represented according to their relative developments, they appear about as follows:

Cimarron	1
Oklahoman	2
Missourian	4
Des Moines	1
Arkansan	35
Mississippian	5

In the general geological scheme, which is dual in character, the time ratios are as important as those represented by the stratigraphy. Faunal and floral comparisons of the different sections are not possible at this time because exact information is scant. We have, therefore, to rely upon data derived from all the available sources. Assuming that the time occupied in the formation of the Des Moines series, according to the corrected valuation hereafter considered, as unity, the factors tending to modify the accepted values indicated by the thickness of the several series may be briefly enumerated.

The Mississippian series is predominantly a limestone formation. Taken alone, its lithological composition would indicate a long time element. As a matter of fact, its formation was probably much more rapid than is usual among limestones. The major member is made up of a crinoidal and shell breccia. The accumulation of its material would thus take place many times faster than the formation of fine-grained, non-fossiliferous beds through ordinary precipitation. Another feature indicating that the period during which the Mississippian beds were laid down was not so long as might appear at first glance, is the undoubted oscillation of the sea-floor, which grew quite marked towards the close of the period. In these changes of elevation the uprisings at length predominated over the down-sinkings, finally resulting in the complete emergence of a large part of the province above sea-level, and closing the Mississipp-

pian period. Over the entire area now known as the Upper Mississippi valley a prolonged period of subaerial erosion took the place of sedimentation. West of the line now occupied by Mississippi river the land border extended southward beyond the latitude of the present Missouri-Arkansas boundary, as lately clearly shown by Marbut.* The full significance of this position of the old shore-line at the close of the Lower Carboniferous is considered elsewhere.† Taken in all its various aspects, the data at hand indicate that the length of time occupied in the formation of the Mississippian was but little more than that during which the Des Moines series was laid down. Compared with the Des Moines, the Mississippian should probably be placed at about one and one-half.

The enormous development of Coal-measures in central Arkansas has been an anomaly in the stratigraphy of the Carboniferous. The thickness, estimated by Branner‡ to be over 20,000 feet, is much greater than that of the entire Carboniferous elsewhere on the American continent. The conditions permitting this vast accumulation were certainly very local and unusual. They are briefly stated§ as follows: South of the latitude of the Boston mountains in northern Arkansas, Carboniferous sedimentation continued on without interruption from the Mississippian; while in the north erosion took place. The sediments from the northern land area, where erosion was going on vigorously, were carried southward and dumped off the shore, rapidly building the latter outward.

There may have been a great land area in northern Louisiana, and probably was. If so, what is now the Arkansas River valley was a broad deep estuary opening out to the west, and the sediments came in from both sides, as well as from the head towards the east. The conditions were then similar to those presented now by the lower Mississippi plain. Only the great embayment opened to the west instead of to the south.

The present Arkansas valley, however, has probably been formed through erosion largely, if not entirely, since Tertiary times and by a system of drainage in no way dependent upon the Carboniferous drainage. When the great uplift of Missouri and Arkansas rose, the northern part, embracing the so-called Ozark isle, and the southern portion, comprising the Ouachita mountains, were made up of resistant limestones, and yielded less quickly to erosion than the central soft shales; and the Arkansas river, which happened, in the old peneplain, to traverse the central part of the uplifted area, was able to main-

* Missouri Geol. Sur., vol. x, 1896, p. 83.

† Bull. Geol. Soc. America, vol. xii, 1901, p. 173.

‡ This Journal (4), vol. ii, 1896, p. 235.

§ Bull. Geol. Soc. America, vol. xii, 1901, p. 195.

tain its old course. The present uplift, which is due to one general movement, is now apparently divided into two elevated regions separated by a broad valley.

While in the south there is this prodigious record of the strata, in the north there is no record at all in sediments. The period of erosion is represented by only a thin irregular plane of unconformity from which alone no time value can be determined. In spite of the enormous thickness of the Arkansan, the time element must have been very much less than would ordinarily be inferred from the figures relating to the vertical interval occupied. The period might have been as extended as the Mississippian; but, all things considered, it would seem much more likely that it was actually considerably more limited than that of the series immediately below. Probably the time ratio would be very nearly the same as for the Des Moines.

Although the Des Moines series is so thin over such a large part of the area occupied by it, it is actually very much more important as a terrane than its relative thickness would indicate. North of the Boston mountains the formation is perhaps nowhere over 500 feet in thickness. The beds composing the series were laid down along a shore which was on the whole gradually sinking.* Many oscillations permitted sub-aerial erosion to take place time and again, so that the newly formed sediments were frequently removed or worked over almost as fast as they were formed. It was a period when erosion contended against deposition for supremacy, with a result of one making advances at one time and the other at another. The net result was finally a slight gain for sedimentation.† The period was manifestly a long one, for it is believed that in Arkansas no less than 3,500 feet of strata are referable to it. Its time ratio is certainly not very much less than that of the Mississippian.

The Missourian series is essentially a marine formation intercalated between two terranes which were laid down in shallow waters. Its limestones are nowhere the coarse-grained breccias such as occur so frequently in the Mississippian. They are fine-grained and often earthy, and are separated from each other by important beds of shale, which are moreover usually much thicker, reaching measurements of often several hundreds of feet.‡ It is not improbable that part of these beds were laid down while some of the nearer shore sediments of the Des Moines series were being carried into still waters.§

* Iowa Geol. Sur., vol. ii, 1894, p. 113.

† This Journal (3), vol. xh, 1891, p. 273.

‡ American Geologist, vol. xxiii, 1899, p. 298.

§ Iowa Geol. Sur., vol. ii, 1894, p. 162.

In point of the time taken for its formation, the Missourian series may be regarded as ranking with the Mississippian.

The so-called Permian of the Western Interior basin (Oklahoman and Cimarron, the latter generally known as the Red Beds) is composed largely of shales and shaly sandstones. Unusual conditions prevailed during the formation of these beds. In the main, the deposits indicate the presence of shallow waters, in strong contrast to the marine conditions which prevailed previously in the same region. The sediments were laid down largely in more or less closed basins, which may have often had access to the sea, but which finally became altogether dry.

The conditions existing were identical with those under which the original Permian beds of Russia were formed.* Notwithstanding the comparatively great development of the beds of these series, the formation of them was evidently rapid. The time occupied was probably not more than twice as long as that of the Missourian.

Careful comparison of all available data indicates that the actual time ratios for all the series is very nearly equal. All things considered, this appears quite remarkable. The values seem best to accord with the following figures :

Cimarron	1
Oklahoman	1
Missourian	1½
Des Moines	1
Arkansan	1
Mississippian	1½

* *Journal Geology*, vol. vii, 1899, p. 320.

ART. XXXIV.—*The Spectra of Hydrogen and some of its Compounds*; by JOHN TROWBRIDGE. (With Plate VI.)

IN a late paper I expressed the conviction that the so-called line spectrum of hydrogen cannot be considered apart from the spectrum of water vapor; and that one can never be sure that one is observing with a condenser discharge a pure spectrum of hydrogen. I am convinced from further experimentation that this conclusion is correct; and I am also led to the conclusion that a certain amount of water vapor is essential in all electrical discharges through gases. Just as aqueous vapor seems to play an important role in most chemical reactions, so, it seems to me, its presence in rarified gases contained in ordinary glass tubes, enables a dissociation to take place which determines the strength and character of the electrical discharges.

I am led, moreover, to the conclusion that pure hydrogen is a perfect insulator, and that the passage of electricity through a gas depends upon the dissociation of the hydrogen and oxygen, by means of which change in the distribution of energy the gases are made luminous. Before proceeding to an account of my experiments, I will state some of the grounds upon which I base my belief that pure hydrogen is an insulator of electricity.

V. Schumann, in an important paper, has shown that a column of pure hydrogen at atmospheric pressure transmits the ultra-violet rays as well as the most perfect vacuum he has been able to obtain. Now Maxwell's electromagnetic theory of light demands that the space between us and the sun, or in other words the vacuum of space, should be a perfect insulator, otherwise the electromagnetic waves would be completely absorbed and the earth would remain in darkness. This observation of Schumann seems to me one of the most important in physical science, for it proves, I believe incontestably, that hydrogen cannot be a conductor.

Professor Dewar has also shown that liquid hydrogen is an insulator. The experiment sometimes shown, in which a wire, rendered incandescent by a current of electricity and surrounded by an atmosphere of carbonic dioxide, is suddenly diminished in brilliancy by supplanting this atmosphere by one of hydrogen, can be explained, in my opinion, not by the better conductivity of hydrogen for heat, but by the increased resistance of platinum due to the occlusion of this gas by platinum. A

* Ann. d. Physik, No. 3, 1901, p. 642; this Journal, May, 1901, p. 394.

palladium wire increases often as much as fifty per cent. by the occlusion of hydrogen.

The increased length of the electric spark in an atmosphere of hydrogen is not due to an increased conductivity, but to a dissociation of water vapor which is analogous to that which takes place in a voltaic cell.

These are some of the facts which lead me to believe that hydrogen is an insulator and that the water vapor, therefore, plays a controlling part in the passage of electricity through gases. I am conscious that the conclusions in this paper are somewhat radical; and I have, therefore, worked assiduously, during the past three years, to test them in every way which my mind suggested, for it is not probable that many investigators have at present twenty thousand storage cells, which would enable them to repeat my experiments. The strength of currents and the voltage I have employed have certainly reached the limits of glass tubes to withstand such powerful discharges. The form of tube figured in my previous article* is the only one which I have found capable of withstanding steady currents of one-tenth to one-fifth of an ampere, and instantaneous condenser discharges of many hundred amperes.

The great advantage of the use of a storage battery over the employment of a Ruhmkorf coil; in the study of the ionization and molinization of gases, is now generally recognized. This advantage is forcibly seen in the first experiment which I shall bring forward in support of my view of the importance of the rôle played by water vapor in the passage of electricity through gases. A wide tube of the type I have referred to, the narrow portion being approximately one centimeter, was provided with massive copper-ring electrodes, one inch in outside diameter and one-eighth of an inch thick, which were heavily electroplated with copper in order to avoid the impurities of commercial copper. The glass tubes were then exhausted and filled with hydrogen made by the electrolysis of distilled water and phosphoric pentoxide. The gas was sent through tubes filled with caustic potash and many drying tubes filled with phosphoric pentoxide. The gas was kept in the drying tubes many hours; and its flow was delayed by partitions of glass wool. More than a litre of the gas was used in the process of flushing out the spectrum tubes; so that the entire pump and connecting tubes were for several hours presumably filled with hydrogen gas.

When the tubes, having been exhausted to the most luminous stage, were excited by a condenser discharge and were examined by a straight-vision spectroscope, the ordinary four-

* This Journal, x, 222, 1900.

line spectrum of hydrogen alone seemed to be present. When, however, the invisible portion in the violet was photographed, the bands at wave lengths 3900 and 4315 were invariably present, unless the tube had been maintained, during the process of filling, to a temperature of more than 350° C. After such a process of heating the spectrum became that represented in Plate VI, fig. 2, while before heating it was that shown in Plate VI, fig. 1. In both plates the normal spectrum is above the gaseous spectra. Further toward the ultra-violet, under all conditions, there were also nitrogen bands. Long heating diminished the strength of these bands. This process of experimentation shows that mere eye inspection of glass tubes filled with rarified gases is generally fallacious; we might conclude from this eye study that the presence alone of the four lines of hydrogen denoted that we had this gas in a pure state; whereas the photography of the invisible portion would show that this was far from the truth.

When the glass tubes filled with rarified hydrogen were submitted to the influence of a steady current of electricity, it was found that perfectly pure copper was deposited in a lustrous state on the glass walls of the tube which surrounded the negative terminal, while an olive-green oxide of copper covered the walls around the positive terminal. The same tube was excited by a Ruhmkorf coil, and no difference could be detected in the deposits around both terminals; they were both rusty green with here and there, it may be, streaks of pure copper. The mirrors produced by a strong steady current at the negative terminal were very lustrous and showed no trace of an oxide of copper. It was evident that the current had dissociated water vapor in the presence of an excess of hydrogen, and had reduced the copper at the negative pole and had set free oxygen at the positive pole, which had, in turn, combined with copper. The rarified gases thus acted like a voltaic cell.

When we examine the photograph of the discharge represented on Plate VI we see an interesting exhibition of ionization and molinization. The hydrocarbon bands at wave length 4315 show a series gradually decreasing in length of waves, while another band beginning at wave length 3900, due probably to water vapor, shows a series increasing in length of waves. It would seem that the carbon in one case endeavored to throw off the hydrogen from the hydrocarbon molecule; and in the other case the hydrogen became loaded with oxygen molecules. This to and fro ionization and molinization continues until the oxide of copper at the positive terminal has taken up a large share of the oxygen of the water vapor present. There is thus a critical point in the tube at which a sudden increase of resist-

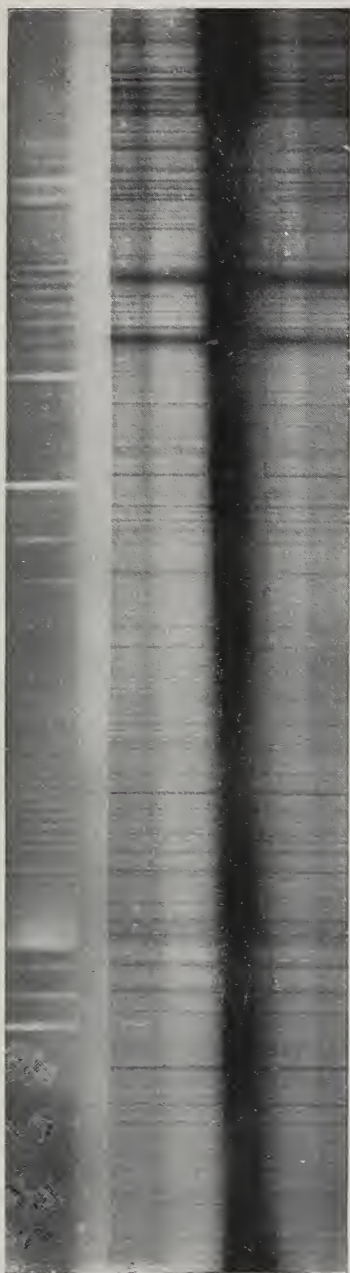

1

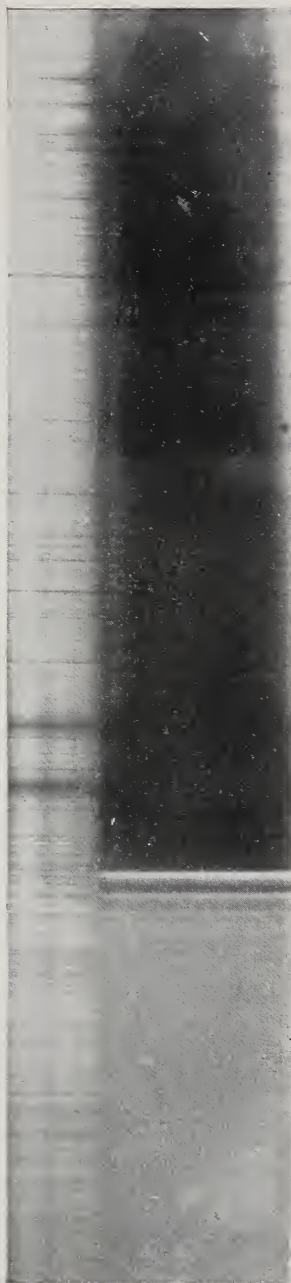

2

ance takes place. It is possible to exhaust glass tubes to such a degree by the mere passage of a strong steady current that X-rays begin to manifest themselves.

When a similar tube, filled with hydrogen with great care and prepared by long heating at a temperature a little below 500° C., is submitted to electrical discharges, the water vapor bands become far less pronounced; and the hydrocarbon band at wave length 4315 entirely disappears, while the light of the tube greatly diminishes in brilliancy. The hydrocarbon or cyanogen band at wave length 3884 is present in all the tubes I have employed; and with whatever gas is submitted to these strong discharges. Strong heating does not cause it to disappear, and it seems to be due to carbonaceous matter introduced into the tubes in the process of blowing for I cannot trace it to impurities coming from the pump. Professor Hartley, in a late communication in *Nature*, has called attention to the constant presence of hydrocarbon spectra in Geissler tubes. At a later point in this paper I shall return to a further study of these spectra, due to the combination of hydrogen and nitrogen with carbon. At present I desire to dwell upon the point I wish to make: that all discharges in rarified gases contained in glass vessels are conditioned by the amount of water vapor present; and that a steady current passes through a gas at comparatively low pressure much in the same manner that it does through an electrolyte.

In an article on the production of the X-rays by a steady battery current, I dwelt upon the phenomena presented in highly rarified tubes which represent, to my mind, the dissociation of water vapor; and I will refer again at this point to the phenomena already described. According to this hypothesis the rarified water vapor is dissociated at the surface of the anticathode, which is thus greatly heated; the occluded hydrogen plays a part in this phenomenon.

The behavior of large aluminum electrodes in glass vessels filled with ammonia gas is also an interesting example of the dissociation of water vapor. The gas was obtained by heating ammonium chloride, passing it over freshly slaked lime and through drying tubes filled with phosphoric pentoxide. A sufficient amount of ammonia gas was thus obtained for the purposes of spectrum analysis.

When a large condenser, charged to a difference of potential of twenty thousand volts, was discharged through the rarified ammonia gas—there being practically no self-induction in the circuit, and the main effect, therefore, was due to the pilot discharge—the light of the tube changed from a brilliant white to a rosy red; and eye inspection with a straight-vision spectro-

scope showed only the line spectrum of hydrogen. One would conclude from this inspection alone that there was pure hydrogen in the tube. One might also surmise that the oxygen of the water vapor always present on the walls of the glass vessel had combined with the aluminum terminals, setting free the hydrogen which then carried the current. The pressure, however, in the tube increased, and therefore gas must have come from the aluminum. In the exhaustion of X-ray tubes provided with aluminum cathodes much time and long treatment with condenser discharges is necessary to drive out the gases from this cathode. The principal gas seems, from the experiment with ammonia gas, to be oxygen. The same phenomenon is seen in tubes supplied with magnesium terminals, but to a much less extent. It is not seen when the terminals are of copper, iron, silver, platinum or carbon. This behavior of aluminum toward oxygen is very suggestive in regard to the ready passage of the X-rays through this metal.

I have been unable, with the conditions under which I have worked, namely, the use of very powerful discharges, to obtain the spectra of hydrogen apart from water vapor and hydrocarbons. The study, therefore, of the spectra of hydrogen compels one to carefully study the spectra of the hydrocarbons and that of cyanogen; for I am forced to the conclusion that the combination of hydrogen with oxygen is a controlling factor in all discharges through rarified gases. The following is a preliminary study of some of these compounds, which is added at this stage of my inquiry to illustrate this theory. When various gases are put in tubes provided with carbon electrodes and these tubes are exhausted to a pressure of from one to two millimeters the resultant spectra are very similar. The following gases have been studied in the neighborhood of the great H H lines of the solar spectrum:

Hydrogen
Oxygen
Nitrogen

In the hydrogen tube the only lines that appeared in the region from 4320 to 3200 were:

4268 very intense
3922 faint.

The tube was very thoroughly heated while it was being exhausted. The above mentioned lines do not generally appear with hydrogen in tubes with metallic electrodes; but with a tube with platinum electrodes, filled with hydrogen, and heated for two hours during exhaustion at a temperature of

350° C., the same two lines appeared, and in addition the following very faint lines :

3871
3886

These same four lines also appear in carbon tubes when filled with oxygen. In addition, the following lines are present :

3936
3971
4077

All these lines appear in the nitrogen tube, and in addition :

3883
3876
3868
3856
3849
3841

None of these lines appear in tubes with metallic electrodes filled with nitrogen; and they are therefore not nitrogen lines. All the lines in the nitrogen tube are more intense than those in the oxygen tube, and it is possible that with a longer exposure these additional lines would come out in the oxygen.

To study the effect of the carbon terminals, the following gaseous compounds were put into wide tubes provided with copper terminals and rendered luminous by condenser discharges :

Cyanogen
Carbon monoxide
Carbon dioxide
Acetylene.

Cyanogen was prepared by heating mercuric cyanide and passing the gas over sulphur to remove any traces of mercury vapor. Carbon monoxide was prepared by heating potassium oxalate with concentrated sulphuric acid and passing the gas over potassium hydroxide, and collecting over water. Carbon dioxide was prepared by treating potassium carbonate with dilute sulphuric acid and collecting over water. All of these gases were allowed to remain in contact with pentoxide before introduction into the tubes.

With acetylene, carbon monoxide, and carbon dioxide, condenser discharges being employed, the results appear to be identical with those obtained with hydrogen in the tube with carbon electrodes. With cyanogen the same lines appear; and in addition, the bands which are characteristic of these gases

with continuous currents, which will be described later. In general, with condenser discharges, all these spectra are the same; the differences which occasionally appear may be due to changes in pressure, time of exposure, etc.

The line 4268 in all these cases is by far the most prominent line present in the region studied, and may be taken as characteristic of hydrogen, oxygen, and nitrogen in tubes with carbon terminals, and of gaseous carbon compounds in tubes with metallic terminals. This line does not usually appear in hydrogen in tubes with metallic terminals; occasionally it appears very faintly. It appears, however, very strongly in a tube provided with platinum terminals which is filled with hydrogen and heated for two hours during exhaustion to a temperature of 350° C. The spectrum, in this case, appears to be identical with the spectrum of hydrogen in a tube provided with carbon terminals. Were it not for this fact, it would seem as if this line were due to carbon in some form; but even with this fact, it is possible that there was enough foreign carbonaceous matter present in the platinum tube to produce the result noted.

Eder and Valenta* find, among others, the following lines in the spectrum of an induction coil between carbon terminals:

4268

3921

Apparently these are the same lines found in the tubes provided with carbon electrodes; and also in tubes with metallic electrodes which are filled with carbon compounds. Observed visually, with a straight-vision spectroscopie, all the above cases appear identical. When, for instance, hydrogen was put into the tube with carbon terminals and submitted to discharges from an induction coil, at first the line spectrum of hydrogen appeared. After the discharge had passed for some time, this gradually changed into the characteristic band spectrum of carbon. To the eye alone the change was equally noticeable; the light being, at first, reddish, and then changing to a white. Similar changes were noticed when nitrogen and oxygen were used in the carbon tube.

It seems to me that the following conclusions can be drawn provisionally from the above: When various elementary gases are introduced into wide tubes with carbon electrodes and exhausted to a pressure of 1–2^{mm}, and submitted to condenser discharges, compounds of carbon with the various gases are formed. With nitrogen this compound is probably cyanogen; with hydrogen acetylene; but when a photograph of the spectrum in each case is taken, we get, not the spectrum of the

* Beiblätter, xviii, 1894, p. 753.

compound, nor that of the elementary gas, but a carbon spectrum. This, however, does not mean that we get the line spectrum of elementary carbon; for it is certain that there is water vapor present in the tubes, notwithstanding the temperature to which it has been subjected. The carbon may then unite with the oxygen of the water vapor, forming either carbon monoxide or dioxide; the hydrogen being occluded by the terminals or the glass walls.

Just as the spectra of gaseous carbon compounds in wide tubes with metallic terminals appear identical with the spectra of elementary gases in tubes with carbon electrodes submitted to condenser discharges, so we should expect that the spectra produced would be the same in the two cases. This is found to be true. The general appearance of the photographs obtained with continuous currents is very different from those obtained with condenser discharges. In the former case there is a marked band appearance in addition to a line spectrum. The most prominent of these bands in the region studied is the one beginning at 3884. With the dispersion used this band consists of five prominent lines crowding together toward the ultra-violet. A somewhat similar band, apparently of six lines, begins at 4216. Another band, rather faint, consisting of a large number of fine lines shading off toward the ultra-violet, begins at 4126. The bands beginning at 4216 and 4884 appear to be the same as the bands which Kayser and Runge* designate respectively as the second and third cyanogen bands in the arc spectrum of carbon in air.

Besides these bands a number of single lines appear which are common to all the gases. Among these, the most prominent are:

3652
4048
4080
4360

In the tube filled with cyanogen many of the same lines that appear in tubes with metallic terminals filled with nitrogen are present besides the above. This is true to a certain extent of the other gases; and it is not surprising, since it is to be expected that some atmospheric air is always present as an impurity.

The conclusions to be drawn from these experiments with steady currents are similar to those we have deduced from condenser discharges. When elementary gases are introduced into tubes with carbon terminals and exhausted to a pressure

* *Abhandlungen der Akademie der Wissensch. zu Berlin*, 1889.

of 1–2^{mm}, and are submitted to continuous currents, we obtain the spectrum of carbon or some compound of carbon. From the above results very little information can be obtained as to what this compound is. The same spectrum is obtained whatever gas is introduced into the tube; and moreover, this is the same spectrum which is given by gaseous carbon compounds in tubes with metallic terminals.

What, then, are the conclusions to be drawn from the present stage of this investigation with gases submitted to powerful electric discharges? It seems to me they are as follows:

1. Hydrogen is an insulator.
2. The passage of electricity through hydrogen, nitrogen, oxygen and their gaseous compounds, is conditioned by the water vapor present.
3. The dissociation of this water vapor in the case of tubes filled apparently with pure hydrogen, under the effect of a strong steady current of electricity, shows an electrolytic action closely analogous to that of the voltaic cell. In the case of electrolytic copper terminals in an atmosphere of hydrogen, pure copper is deposited from the negative terminal; and a suboxide of copper at the positive terminal.
4. Under the effect of powerful condenser discharges oxygen is set free from commercial aluminum and magnesium.
5. Certain carbon bands are always present in glass tubes filled with hydrogen, nitrogen, oxygen and ammonia gas notwithstanding the greatest care which may be taken in submitting them, during the process of exhausting, to a high temperature, when powerful discharges are employed.
6. The brilliancy of the light of tubes filled with hydrogen diminishes as the process of the dissociation of water vapor goes on and the resistance of the tube increases. It is possible to raise such a tube to the X-ray stage from a pressure of 1–2^{mm} merely by the application of a strong steady current.
7. The X-rays excited by the application of a steady current are due to the radiations set up by the dissociation of highly rarified water vapor.

Jefferson Physical Laboratory,
Harvard University.

SCIENTIFIC INTELLIGENCE.

I. CHEMISTRY AND PHYSICS.

1. *Induced Radio-activity produced by Salts of Radium.*—

An interesting series of experiments has been made by P. CURIE and A. DEBIERNE, which shows that radio-activity is transmitted in the air through short distances and induces activity in other substances. This induced activity is much more intense when it is produced in completely closed vessels than when the action takes place in the open air. A radiferous substance was placed in a small open bulb in a closed vessel, and plates of various substances (lead, copper, aluminium, glass, ebonite, card, paraffin, all of which appear to be acted on in about the same manner) were placed in various positions in the vessel, and in all positions, even behind a lead screen, they became active to about the same extent after a day's exposure, provided that the air of the vessel had free access to their surfaces. A plate resting on the bottom of the vessel became active only on its exposed surface. With very active barium chloride (radium), plates exposed for several days in this way attained an activity 8000 times greater than a plate of metallic uranium of the same dimensions. When exposed to the free air, the plates lose the greater part of their activity in a day, but the activity disappears much more slowly when the plates are left in the closed vessel after the active substance has been removed. If the experiment is made with the bulb containing the active substance completely closed, no induced activity is obtained. Other experiments showed that this induction is rapidly carried through capillary tubes connecting small closed spaces. It was found that the action is progressive, finally reaching a limit which depends upon the activity of the active body. The action is more rapid the smaller the vessel containing the bodies. These phenomena have been observed with various salts of active barium, such as the chloride, sulphate, and carbonate. Salts of actinium also produce induced activity, but, on the other hand, salts of polonium, even when very active, produce no such effect. The authors believe that this circumstance may have a connection with the fact that polonium does not emit rays that are deviated by the magnetic field.

In a subsequent communication the same authors state that water can be rendered radio-active either by distilling it from a solution of radium chloride in an air-tight vessel, by placing a dish of water in a closed space containing a solution of a radium salt, or also by enclosing a solution of a radium salt in a hermetically closed celluloid capsule and plunging the latter into distilled water in a closed vessel. In the last case, no trace of the salt passes into the water, but the activity of the solution is to a great extent communicated to it. This induced activity can-

not be transmitted by air through a wall of dry celluloid, but it passes easily if the wall is wet with a drop of water. Water can be rendered very strongly active, but when kept in a sealed tube it loses the greater part of its activity in a few days. When kept in an open vessel the water loses its activity much more rapidly, the loss being the more rapid the greater the surface exposed to the air. Solutions of radium salts in open vessels behave in the same way as the water just mentioned, but in this case the loss of activity is not absolute, for if such a solution is put into a sealed tube it gradually acquires its original activity in the course of ten days or so. The authors look upon radio-activity as being analogous to heat in being dissipated by radiation and by conduction. In the latter case it passes through gases and liquids, but not through solids. If a solid radio-active body is left free to the air, its activity does not diminish sensibly, and the authors have shown that a solution of a salt produces much more intense phenomena of induced radio-activity (twenty times greater) than the solid salt itself. When the salt has been in solution several days, the radio-active energy is divided between the salt and the water, and if the latter be then distilled off, it contains a great part of the activity, while the solid salt is much less active (ten or fifteen times, for example) than before solution. When left to itself the solid salt regains, little by little, its original activity. The communication of the activity of a radium salt to its water of solution is very slow, and equilibrium is obtained only after about ten days.—*Comptes Rendus*, cxxxii, No. 9; cxxxiii, No. 5.

H. L. W.

2. *A New Method of Quantitative Analysis*.—R. W. THATCHER has devised a method for determining the weights of precipitates without separating them from the liquid from which they are precipitated. The proposed method consists in determining the weight of a measured volume of the precipitate and mother-liquor, and then determining the specific gravity of the mother-liquor alone. From these data, if the specific gravity of the precipitate is known, the weight of the latter may be calculated by the formula,

$$x = \frac{d(a - bd')}{d - d'}$$

where a is the total weight, b the total volume, d the specific gravity of the precipitate, and d' the specific gravity of the liquid. In order to apply the method, the author determined the specific gravities of a number of precipitates by using known quantities of soluble compounds of the substances to be determined, precipitating as usual in this process, and determining the specific gravities of the mixture and of the mother-liquor. A modification of the formula that has been given then served to give the required specific gravities. The analytical operations were carried out by the use of two Geissler specific gravity bottles of 100 and 50^{cc} capacity. A precipitation was first made in

a volume less than that of the larger bottle, the whole was transferred to the latter at a temperature below 20°, which was used as the temperature for weighing, and the bottle was filled with water, the contents thoroughly mixed, and the whole finally weighed. To obtain the mother-liquor free from the precipitate, the contents of the bottle were transferred to a test-tube and whirled in a centrifugal machine. For settling most precipitates less than one minute was required, while in no case was it necessary to spin the apparatus more than three minutes. The clear liquid was then drawn off by means of a dry pipette, and its specific gravity was taken in the smaller Geissler bottle. The author has applied the method to the determination of chlorine as silver chloride, sulphur as barium sulphate, calcium as oxalate, phosphoric acid as ammonium phosphomolybdate and invert sugar by means of the cuprous oxide precipitated, with very satisfactory results. The method requires that the composition of the precipitate should be constant, although it need not be exactly known. It was found that the specific gravity of aluminium hydroxide varies with the time that elapses after precipitation, so that the method is not yet applicable to the determination of this substance. It is expected that the method will find considerable application, particularly for rapid work in technical analysis, but it requires very accurate specific gravity determinations where quantities of about one gram are taken, a circumstance which will probably limit its adoption by analytical chemists.—*Jour. Amer. Chem. Soc.*, xxiii, 644. H. L. W.

3. *Europium, a New Element*.—By a long series of fractionations with magnesium nitrate DEMARÇAY has separated an earth, intermediate between gadolinium and samarium oxides, of sufficient purity to show no samarium lines, and only mere traces of gadolinium lines in the spectrum. The solutions give absorption-bands, and when traces of calcium sulphate are added to the oxide a brilliant phosphorescent spectrum is produced. The approximate atomic weight 151 is mentioned, but no details in regard to the determination, nor any account of the chemical properties of the substance are given. Numerous spectrum lines are described, however, and the name given above is proposed for the element.—*Chem. News*, lxxxiv, 1. H. L. W.

4. *Research Papers from the Kent Chemical Laboratory of Yale University*; edited by FRANK AUSTIN GOOCH, Professor of Chemistry in Yale University. In two volumes: Vol. I, pp. xiv, 411; Vol. II, pp. x, 415. New York, 1901 (Charles Scribner's Sons, price \$7.50 net).—This work forms part of the "Yale Bicentennial Publications," a series of volumes prepared by the Professors and Instructors of Yale University and issued in connection with the Bicentennial Anniversary to be held Oct. 20–23 of the present year; the series is designed as "a partial indication of the studies in which the University teachers are engaged."

The Kent Chemical Laboratory established at New Haven

through the liberality of Mr. Albert Emmett Kent, was opened in 1888 under the direction of Professor F. A. Gooch. The original research work accomplished in the laboratory since that time by Professor Gooch and his students is now presented together in these two volumes. One hundred and eight papers are included, the larger part of them upon analytical processes in inorganic chemistry. A critical review of these papers is not called for in this place since almost all of them have been published in the pages of this Journal from vol. xxxix, 1890, to the current volume. This collection of papers speaks most strongly for the large amount of excellent original work which has been accomplished in this laboratory.

5. *Magnetic Effect of Electrical Convection.*—A discussion of the experiments of Rowland and of Cremieu upon this subject is given by H. A. WILSON in the July number (pp. 144–150) of the *Philosophical Magazine*; the object of the paper being to point out that Cremieu's failure to confirm Rowland's results is to be attributed rather to the methods employed than to the non-existence of these effects. The author's conclusions are stated as follows:

“(1) That in Cremieu's attempt to detect the electrostatic effect of a varying magnetic field, the effect of the steady magnetic field on the charging currents was left out of account, and that his latter effect is equal and opposite to the former.

(2) That, consequently, Cremieu's negative result constitutes an indirect proof of the existence of an electrostatic effect of a varying magnetic field, of the amount usually predicted theoretically.

(3) That in Cremieu's attempt to repeat Rowland's experiment, his addition of a metallic screen placed close up to the fixed sectors should cause a current to be produced which should almost entirely compensate the desired effect.

(4) That Cremieu's partial failure without the additional screen, is quite possibly due to defective insulation of his sectors.”

The experiments of H. Pender upon the same subject, briefly stated in the *Johns Hopkins University Bulletin* No. 152 (this *Journal*, xii, p. 173), are discussed at length in the August number of the *Philosophical Magazine*.

✓ 6. *The Effect of Amalgamated Gases on Resistance*; by WILLIAM ROLLINS. (Communicated.)—As the result of experiments with X-light tubes, I concluded that we depend on gases amalgamated with the terminals of a vacuum tube for an efficient cathode stream for producing X-light. It, therefore, seemed desirable to see if the partial removal of these gases would in any way change the resistance of the metal forming the terminals. Spiral terminals were made, the ends of each spiral being brought to the outside of the tube so that a current could be sent through the spirals before the X-light tube was pumped and after as much gas as possible had been removed from the metal by heat, electricity and pumping. Mr. Oelling and Mr. Heinze constructed

the tubes and made the tests during the summer of 1900. They reported that the resistance of a wire was increased by removing the amalgamated gases. In one experiment the resistance of the wire forming a spiral terminal in an X-light tube was .068 of an ohm before and .080 after. The instruments for making the experiments were not of a high grade. On this account the results were not reported, as I hoped to repeat the experiments with better apparatus and with terminals made of all the common metals. As this opportunity has not come, I now report the experiments that some one better equipped may extend them.

II. MISCELLANEOUS SCIENTIFIC INTELLIGENCE.

1. *American Association*.—The fiftieth annual meeting of the American Association for the Advancement of Science was held at Denver, Colorado, during the week beginning August 24th. The President of the meeting was Professor Charles S. Minot of Cambridge. The attendance was larger than might have been anticipated considering the distance of Denver from Eastern centers, the registration reaching 311; nearly one-third of those in attendance came from the Atlantic coast. The interest taken by the citizens in the proceedings and their efforts for the entertainment of the guests contributed essentially to the success of the meeting. About 220 papers were presented for reading at the sessions of the Association and those of the affiliated societies, which were also well attended. The address of the retiring President, Professor R. S. Woodward, was delivered on the evening of August 27 on the subject "The Progress of Science." The address is printed in full in the issue of *Science* for August 30. The following numbers of the same journal, which is now the official organ of the Association, contain a detailed account of the Denver meeting with the addresses of the Vice Presidents before the several sections.

The place selected for the meeting of 1902 is Pittsburg, the officers to embrace the week from June 28 to July 3. The officers elected are as follows:

President, Asaph Hall.

Vice Presidents: Section A, G. W. Hough, Northwestern University; Section B, W. S. Franklin, Lehigh University; Section C, H. A. Weber, Ohio State University; Section D, J. J. Flather, University of Minnesota; Section E, O. A. Derby, São Paulo, Brazil; Section F, C. C. Nutting, Iowa State University; Section G, D. H. Campbell, Leland Stanford University; Section H, Stewart Culin, University of Pennsylvania; Section I, C. D. Wright, Commissioner of Labor, Washington; Section K, W. H. Welch, Johns Hopkins University.

Permanent Secretary, L. O. Howard of Washington; *General Secretary*, D. T. MacDougal, New York Botanical Gardens; *Treasurer*, R. S. Woodward, Columbia University.

A meeting of the Association will also be held in Washington

during "convocation week," that is the week of Jan. 1st, 1903. This mid-winter meeting is a decided change of policy, but it is left for the future to decide whether the time of meeting shall be permanently changed or whether there shall be two meetings annually.

2. *British Association*.—The meeting of the British Association for the Advancement of Science was held in Glasgow, Sept. 11 to 18. The presidential address was delivered by Prof. A. W. Rücker (see *Nature*, Sept. 12).

3. *Catalogue of the African Plants collected by Dr. Friedrich Welwitsch in 1853-61. Vol. II, Part II, Cryptogamia*, British Museum (Natural History), 1901. Pp. 261-565.—The final portion of this work is especially valuable since it contains accounts by no less than ten specialists of all the divisions of cryptogams from a region where the lower plants had been seldom collected. The groups most fully treated are the fresh water algæ by W. & G. S. West and the lichens by E. A. Wainio. It is stated that the earliest collections of algæ made in Africa are more extensive and representative than any hitherto described. Of the orders of fresh water algæ the Desmidiaceæ and Myxophycæ are best represented. It is of interest to note the occurrence of *Nostochopsis lobatus* Wood, first discovered in the United States, and later found in South America. In looking over the list of fresh water species from Africa, one finds a confirmation of the fact that fresh water algæ are more cosmopolitan in their range than any other plants except perhaps the algæ of brackish water. The marine algæ which were worked up by Miss E. S. Barton are, as might have been expected, much less numerously represented, only forty species being enumerated, and some of these were collected at Madeira and the Cape Verde Islands. The lichens include a large number of new species which are described in detail. The fungi were determined by Miss A. L. Smith, and include the species of Welwitsch previously described by Curry and Lagerheim. Of the four Mycetozoa enumerated by Arthur Lister, two were first found in the United States. The mosses by Antony Gepp, and the hepatics by F. Stephani include a number of new species, and the vascular cryptogams are given by W. Carruthers with the description of but one new species. There is also a general index of both volumes of the catalogue.

W. G. F.

4. *Leitfaden der Wetterkunde, gemeinverständlich bearbeitet*; von Dr. R. BÖRNSTEIN. Pp. 181 with 17 plates and numerous text figures. Braunschweig, 1901 (Fr. Vieweg u. Sohn).—The number of those interested in the science of weather predictions and desirous of having an intelligent knowledge of the meteorological principles upon which they are based has increased very largely in recent years in consequence of the admirable work done by the various Government Bureaus. To them, as also indeed to those who have already had a training in this branch of science, the author's concise and systematic treatment of the subject will be of great value. He discusses all the topics

involved with uniform clearness throughout and—so far as space allows—with much thoroughness. At some points the work contains so much that it will call for close study from those not already well grounded in physical science. An interesting chapter is that giving a brief account of the work of the Weather Bureaus of the various governments. The book is well illustrated, the charts at the end including, for example, the representations of the different types of clouds, being particularly good.

5. *Studien über die Narkose*; von DR. E. OVERTON. Pp. 195. Jena, 1901. G. Fischer.—This monograph contains a review and critique of the more prominent theories of the mode of action of narcotics and anaesthetics. The greater part of the book is taken up with a discussion of the theory of narcosis which has recently been advanced by Professor Hans Meyer of Marburg, and advocated independently by the author. Briefly, this theory assumes that all chemically indifferent compounds which are soluble in fats or similar substances act as narcotics on living protoplasm to the extent to which they are distributed therein. This action will obviously be most pronounced on those tissues which are richest in fat-like compounds, viz., the nervous tissues. The comparative efficiency of various substances as narcotics (anaesthetics) must be dependent on their relative affinity for these fat-containing tissues and the tissue fluids respectively. Dr. Overton has attempted to ascertain this relationship—the coefficient of distribution—for a number of organic compounds which act as narcotics. Many experiments on plants and animals—mostly lower forms—are reported in detail by the author, who is an assistant in botany at the University of Zürich. L. B. M.

6. *Ueber Harmonie und Complication*; von Dr. VICTOR GOLDSCHMIDT. Pp. 136, large 8vo. Berlin, 1901 (Julius Springer).—Starting from some of the fundamental principles of crystallography, the author has attempted to show that analogous laws exist both in the harmonic relations and in their combination in other departments of science—as in sound and light. Thus the so-called harmonic series of numbers of which a simple example is given by $0\frac{1}{2}\cdot 1\cdot 2\cdot \infty$, which in crystallography defines the position of the planes in a crystal in terms of the molecular forces, is believed to fix the positions of most of the notes of the musical scale and also those of the chief Fraunhofer lines in the solar spectrum. It would be impossible in a brief space to make clear the methods of the author in arriving at this conclusion, still less to explain his manifold deductions. The reader cannot fail to appreciate the industrious ingenuity exercised even if not convinced as to the correctness of all the views advanced.

7. *Nature's Miracles: Familiar Talks on Science*; by ELISHA GRAY, Ph.D., LL.D. Vol. III. Electricity and Magnetism. Pp. 248, 12mo. New York, 1901 (Fords, Howard and Hulbert).—In this little volume the writer presents some of the important topics in electricity and magnetism in simple language and with familiar illustrations, designed to interest the general reader to whom scientific treatises are closed books.

OBITUARY.

CHARLES ANTHONY SCHOTT, for many years a prominent member of the staff of the United States Coast Survey, died on July 31 at the age of seventy-five years. Born at Mannheim, Germany, in 1826, he came to this country at the age of twenty-two and at once entered the service of the United States Coast Survey, in connection with which he was to do such important work. A man of keen, well-trained and original mind, endowed with unlimited energy and industry, his labors, carried on for half a century, have contributed no small part to the grand total accomplished by this Bureau. He was early attached to the Computing Division and in 1855 he assumed charge of this department, a position which he retained until January, 1900; in 1856 he was advanced to the rank of assistant. He is best known for his numerous and important contributions to Terrestrial Magnetism, frequent references to which will be found in these pages. It was in recognition of his services in this direction that in 1898 he received the Wilde Prize from the French Academy. After being relieved of his duties as Chief of the computing division, early in 1900, he was assigned to the discussion of the arc measurements in the United States; the volume entitled "The Transcontinental Triangulation and American Arc of the Parallel" was prepared by him (see this Journal, vol. xi, p. 172, 1901). This important work and another, "The Eastern Oblique Arc of the United States," now about to be issued, form a fitting close to the labors of a long and most useful career.

The following just tribute, adopted Aug. 1 by the members of the Survey, well expresses the estimate of the man formed by those most closely associated with him: "He was enthusiastic, faithful, and diligent in all duties he was called upon to perform, and through his learning and probity earned a reputation extending over two continents which is most worthy of emulation. Conscientious and expert in his specialties, geodesy and terrestrial magnetism, his labors added immeasurably to the reputation of the Bureau and of his comrades who gathered the material he so ably discussed. The methods of computation now in use in the Bureau are an indelible record of his ability. His high ideals of duty and his tireless and persistent striving for them made him stand forth as a noble example of the best type of public official, and his uniform kindness endeared him to those who knew him as a friend."

BARON ADOLF ERIK NORDENSKIÖLD died at Stockholm on August 12 in his sixty-ninth year. He was alike renowned for his numerous and important contributions to the Mineralogy and Geology of Scandinavia and even more for his intrepid explorations in the far north.

DR. WILHELM SCHUR, Professor of Astronomy at Göttingen, well known both for his researches and his work as a teacher, died the past summer at the age of fifty-five years.

BARON DE LACAZE-DUTHIERS, the celebrated French zoologist, Professor in the Sorbonne, died on July 21 in his eighty-first year.

THE

AMERICAN JOURNAL OF SCIENCE

[FOURTH SERIES.]

ART. XXXV.—*On the Effect of Temperature and of Moisture on the Emanation of Phosphorus, and on a Distinction in the Behavior of Nuclei and of Ions*; by C. BARUS.

Introduction.

1. *Object, etc.*—Endeavoring to differentiate the properties of the nucleus and the ion, it occurred to me that the effects of temperature, when worked out simultaneously by the volumetric and by the electrical methods, would probably present a contrast. If the two functions relating to condensation and to electrical conduction are different, then their thermal variations are not likely to be the same. The temperature which insures the maximum production does not also necessarily insure maximum instability. The results of the following paper bear out this surmise.

Again, if phosphorus is to be used as an ionizer, some definite knowledge as to the cause of its variable intensity is essential from a practical point of view. The substance is so remarkably adapted for the purpose in many ways, that the endeavor to put it in control quantitatively is well worth while. This too, I think, has been accomplished.

Finally I have shown that the low number of ions ($n=2 \times 10^4$ per cubic centimeter) in the saturated phosphorus emanation, found from the experiments with the tubular condenser, is due to non-saturation. I have been able to nearly double this number, putting these results in accord with the data of plate and spherical condensers. Incidentally certain curious conditions under which the emanation produces permanent conduction in the condenser is identified with the occurrence of traces of moisture. This behavior so closely resembles the effects of radio-activity, that the extreme caution needed before such a property can be predicated, becomes apparent.

Volumetric Comparisons.

2. *Apparatus.*—The apparatus to investigate the relation of the emanating activity of phosphorus to temperature is shown in figure 1, the thermal part consisting of a coil of thin lead pipe ($\frac{1}{8}$ inch bore), *L*, submerged in a large water bath of copper, *AB*, 13^{cm} high, 15^{cm} broad, and 20^{cm} long. There were 21 turns of lead pipe, each turn 6^{cm} in diameter. The air coming from the gasometer train by way of a desiccator at *D*, and a stop cock, *F* (fine screw valve), traversed this considerable length of slender tubing, fully taking the temperature of the water bath, thereafter to be discharged into the central straight pipe of brass, *ab*, 1.2^{cm} in diameter, containing the ionizers (not shown). The charged air is finally conveyed into the influx pipe of the color tube, *C*, by the removable short neck, *G*. A thermometer, *t*, is placed in the water bath; another may be inserted into the end, *b*, through a perforated cork, so as to be in contact with the ionizers.

Care was taken that all changes of temperature should be slow. Thus it took 3 hours for the temperature to rise from 5° to 13° in the following experiments, for instance.

The ionizers, as usual, were strips of wire gauze, holding thin pellets of phosphorus between them. They were inserted into, or removed from the tube, *ab* through *b*. If saturation is aimed at, an excess of freshly cut phosphorus surface should

TABLE I.—Effect of the temperature of phosphorus on its emanation. Steam jet method: $p = 4.5^{\text{cm}}$; influx air at 27°–28°.

Color.	$10^2 \times$ dV/dt	θ	Color.	10^2 dV/dt	θ	Color.	$10^2 \times$ dV/dt	θ
Bl*	85	27°	None	----	5°	Bl+	70	12.8°
Bl+	110		None	----	6	Bl	65	12.8
			None	----	7	opaque	80	12.8
			Puffs faint		8.2	Bl	75	13.0
Bl	100	30.8	Puffs strong, }		8.6			
	90	30.7	greenish }		9.0	Bl	85	17.6
Bl	95	28.6	Puffs bluish		9.3	opaque	105	17.6
	100	28.6	Do.		9.8			
Bl	95	25.2	Do. No perma- }		10.2	Bl	90	31.3
	90	25.2	nent color }			Bl+	110	30.8
Bl	80	22.3	Greenish permanent		10.7	Bl	95	30.6
Bl+	90	22.3	Faint yl. }		380	Bl	90	32.6
Bl—	61	18.8	green. }		10.9	Bl+	105	32.4
Bl	90	18.8	Blue gray		280	Bl	100	32.2
Bl	75	18.8	Bl—		350	Bl+	100	35.3
Bl+	115	18.8	All colors came out }		12.8	Bl	110	35.2
Bl+	60	13.2	intensely includ- }			Bl	90	34.9
Bl	60	13.2	ing opaque }					
Bl	70	13.3	.					
opaque	100	13.3	.					

* Bl, blue; Bl+, dark blue; Bl—, light blue; yl, yellow.

be used. This was only done when specially called for in the present work, where the form of the temperature function is the chief consideration.

3. *Method and data.*—The usual method of experiment was adopted, the liters per minute (dV/dt) of saturated phosphorus air necessary to produce the fiducial blue of the color tube, being observed at different temperatures. The data are given in Table I, in the first part of which observations for falling temperature, and in the second for rising temperature, are recorded. The pressure of the steam jet was about $p=4$ to 6^{cm} . The inflowing air showed a temperature of 27° to 28° . The table contains some other colors (including opaque) for orientation.

The chief data of the table are reproduced in the chart figure 3 (p. 334) and show the sudden cessation of reaction at 12° – 13° .

4. *Discussion.*—For the sake of preliminary comparisons with the corresponding electrical charts given below, it is well to lay off $1/(dV/dt)$ in its variation with temperature: for this reciprocal runs parallel to the concentration of the emanation producing the color. The construction is given in figure 4, in which the sudden rise of activity in producing nuclei is apparent at 13° , and the subsequent gradual decline thereafter as far as examined, is again manifest. Anticipating data of subsequent paragraphs, I may add that the maximum ionizing activity is at 20° , showing the two thermal relations to be *non-coincident*.

The charts show in the first place, that as temperature falls from the highest admissible values, say 35° , the emanation of phosphorus actually increases* at a rate of about 2 per cent per fall of 1° C. The maximum activity occurs at about 13° , and is upwards of 25 per cent greater than at 30° . Between 12° and 13° , however, the emanation is quenched at an enormously rapid rate, falling just short of suddenness. Practically, therefore, the reaction begins at about 13° , with full if not greatest intensity.

Below 12° , the emanation is insignificant and the maximum permanent colors obtainable are faint blue grays, even when the gasometer flow is forced to, say 400 liters/minute. There are no opaques. Below 10° there were no permanent colors discernable.

5. Here, however, and slightly above and below this temperature, definite *puffs* of color or of darkness are obtained immediately after opening the faucet suddenly. The phenomenon may be repeated indefinitely by closing the faucet

* This increase may be due to the gradual thorough desiccation of the phosphorus by the dry current of air. These grids were not dried preliminarily over calcium chloride.

for a period of 2–5 seconds (longer at the lower temperatures), and then suddenly opening it again. The puffs are at first vaguely recognized at about 8°, or even below. They become more marked as temperature rises. They are still marked at even 12°, when the fainter colors are beginning to be permanent. They show a maximum degree of darkness depending on temperature, beyond which they do not increase even if the cock is closed indefinitely.

From a theoretical point of view this result is noteworthy. Below the reaction temperature (say 12·5°), what may be called the vapor pressure of the reaction is a definite quantity, but decreases with temperature at an enormously rapid rate; above the reaction temperature, the vapor pressure is relatively constant as temperature increases. All this recalls the well known analogy appropriated by the physical chemist.

Now if we suppose the nuclear velocity to be a relatively constant quantity, within a short range of temperature, while the emanating activity decreases, the density of the emanation formed within the ionizer will clearly diminish as temperature decreases below the reaction temperature, however long the air is in contact with the ionizer. Hence the color of the puffs should gradually become fainter with decreasing temperature, as actually observed. If N nuclei are produced per superficial square centimeter of phosphorus, if k be the corresponding average nuclear velocity and n the number present per cubic centimeter, $N = kn$. Thus n depends on the ratio of N and k . The vapor pressure analogy suggested is not wholly tenable inasmuch as nuclei are actually absorbed at the walls of the vessel (tube *ab*, figure 1), so that N vanishes with n in the lapse of time. Since k is of the order of one unit, N and n may be regarded as about of the same order, roughly speaking. The number of particles generated per square centimeter of the phosphorus will not greatly differ from the number present per cubic centimeter of the emanation.

6. Above the reaction temperature, if the rate of production, N , were regarded as relatively constant, the means of computing the increase of speed of the nucleus with rising temperature would be at hand. If m be the mass of the nucleus and $mk^2/2$ varies as absolute temperature, $k_2/k_1 = \sqrt{(t_2 + 273)/(t_1 + 273)}$. Turning now to the chart, figure 3, let $t_2 = 30^\circ$ and $t_1 = 20^\circ$. Then $k_2/k_1 = 1.02$, whereas the chart gives $k_2/k_1 = 1.25$. These two results being out of keeping with each other, the thermal variation of k is insignificant compared with the corresponding decrease of N .

7. *Data for low temperatures.*—After finishing the electrical investigation presently to be discussed, it seemed desirable

to corroborate the above results with experiments made near the temperature at which phosphorus becomes active. As a whole the new data agreed with the above inferences. It was discovered, however, that permanent though faint colors could be obtained even below the limits stated above (13°), by very gradually increasing the speed of the charged air current from zero until the field showed the limiting coloration for the low temperature selected. When the air current is further increased, however slightly, the field of the color tube at once clears, almost with a flash. It is thus possible to "blow out" the emanating activity of the phosphorus with a current only a trifle faster than the one which produces the corresponding

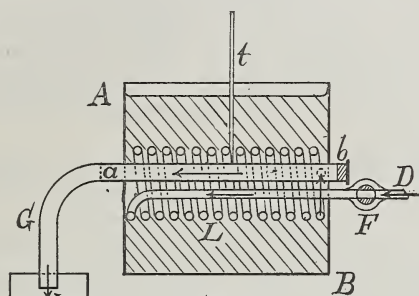

Fig. 1.

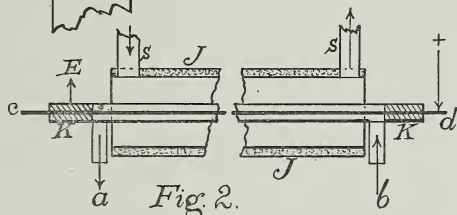

Fig. 2.

color maximum. The puffs of color obtained above are the same phenomenon. Below 13° , opaque did not occur. At 14° the full activity was accentuated.

Electrical Comparisons.

8. *Apparatus.*—It is now desirable to compare these data with the results obtainable in measuring the radial currents when the tubular condenser is made the channel of communication between the pipe, *ab*, of the water bath, figure 1, and the color tube, *C*. In other words, the tubulure, *G*, is now replaced by the condenser, *KK*, figure 2, for discharging ionized air into *C*, by fitting the tubulure *b* to the end *a* of the ionizer, figure 1. Details of adjustment are given in my

earlier papers.* The slender condenser, *KK*, was effectively 50^{cm} long, 32^{cm} in internal, and 60^{cm} in external diameter. The inner face (surface of the rod *cd*) is charged to about 40 volts. The tube *KK*, insulated at the ends from the rod, is put to earth at *E*. The electrical discharge takes place radially from rod to tube, and should occur only when the emanation passes in the cylindrical shell between the faces (14^{cm} thick and 50^{cm} long) entering at *b* and leaving at *a*. It is difficult in so slender an apparatus and in view of the use made of it to avoid conduction through the insulators, altogether, particularly in a damp atmosphere. Hence in the following tables the insulation when the medium is ordinary air, is given; but even if ignored it will not probably affect the relation to temperature. In a warm dry room the insulation is perfect, and advantage was frequently taken of this observation.

A steam or water jacket, *J*, surrounds the condenser for special experiments. § 22. Steam enters and leaves by the tubulures, *s*.

9. *Method.*—The method consisted in reading the efflux volumes, *V*, at the gasometer or aspirator bottle, before and after the series of electrical measurements. As the latter were always duplicated, three volume measurements were made at stated times. From these dV/dt was obtained graphically.

The fall of potential at the electrometer (capacity of the latter 60^{cm}, in parallel with that of the condenser, 39^{cm}) was observed at intervals of 15 seconds apart. Eight readings in two series were made between the volume readings. The initial potential being about 41 volts, and equivalent to 87 or 80 scale parts, respectively, each scale part is equivalent to about half a volt; but the absolute values are without interest. As usual, care was taken to await constancy of temperature in the water bath.

10. *Data.*—In the following Table II, the time of observation in minutes, *t*, the reading of the gasometer, *V*, in liters, the reading of the electrometer in scale parts, *s* (zero at *s*=250), and the temperature, θ , of the water bath are given in successive columns. In the second and third columns, moreover, the rate of efflux of the air, dV/dt , in liters/min., and the initial radial electrical currents ds/dt are tabulated. E_0 is the initial potential difference in volts.

As a rule, two values of dV/dt are entered for each temperature, one for a moderate current of about 50 liter/min. through the condenser and the other for the stronger current of about 1.0 liter/min. From brevity, an example of these data corresponding to a single temperature, $\theta = 15.3^\circ$, will only be given.

* This Journal (4), xi, p. 310, 1901; Phil. Mag. (6), vol. i, p. 572, 1901; *ibid.* (6), ii, p. 40, 1901; and elsewhere.

TABLE II.—Radial currents in the condenser, Phosphorus ionizer at different temperatures. Example of method.

Time, t	$V \times 10^3$	dV/dt (mean) s	ds/dt	θ
7 ^m 30 ^s	70	$\cdot 27 \frac{\text{lit}}{\text{min.}}$		15.3°
9 30	125			
12 30	205			
0 ^s		163	$12 \frac{s}{\text{min.}}$	
15		166		
30		169		
45		172		
13 ^m 30 ^s	280	$\cdot 83 \frac{\text{lit}}{\text{min.}}$		15.3°
15 30	450			
17 30	610			
0 ^s		163	$27 \frac{s}{\text{min.}}$	
15		170		
30		176		
45		183		

II. *Discussion.*—The data of these tables might be constructed without further reduction in a graph where the abscissas are temperatures and the ordinates, ds/dt , proportional to the radial currents. Two curves are suggested, one for the high, and another for the low velocity, dV/dt ; but in view of the slightly different values of dV/dt implied in each, it is better to reduce to two volume standands; $dV/dt = \cdot 45$ liter/min. and 1.00 liter/min. were selected as most nearly coincident with the observations as a whole. The reduction was made compatibly with the results of my earlier paper (l. c.), linearly from two values of dV/dt and ds/dt at each temperature. This linear relation is again incidentally shown in figure 5 at about 19°. The slopes of these lines vary with temperature.

If Q be the charge, s the deflection, C the effective capacity, E the potential difference, A the factor of the electrometer, $Q = CA s$; $i = dQ/dt = CA ds/dt$, where i is the radial current. Thus $i/Q = (ds/dt)/s$.

For the initial currents, as alone measured in this paper, one may always assume the simple exponential relation $Q = Q_0 e^{-x(t-t_0)}$, or $s = s_0 e^{-x(t-t_0)}$, where the subscripts zero refer to the initial charges, deflections, temperatures, etc. Hence, $i_0/Q_0 = (ds/dt)_0/s_0 = -x$, is an appropriate variable for comparing the data. This may also be computed as

$-x = d(\log s)/dt$, but the approximate method of computing ds/dt from observations 15 seconds apart is more convenient.

The corrected values of $-x = (ds/dt)_0/s_0$, when dV/dt is .45 and 1.00 liters per minute, respectively, are given in the graph, figure 6. Different dots correspond to different series. The curves are smoother than the uncorrected results would have been, and the values for low efflux are naturally more certain. For apart from instrumental difficulties, there is at high velocities a danger of interfering with the temperature of the ionizing phosphorus. Swift currents are not so easily cooled in the water bath and intense action of the ionizer contributes its own temperature error. In both curves the conduction of the insulators prevents the curves from actually reaching the abscissa.

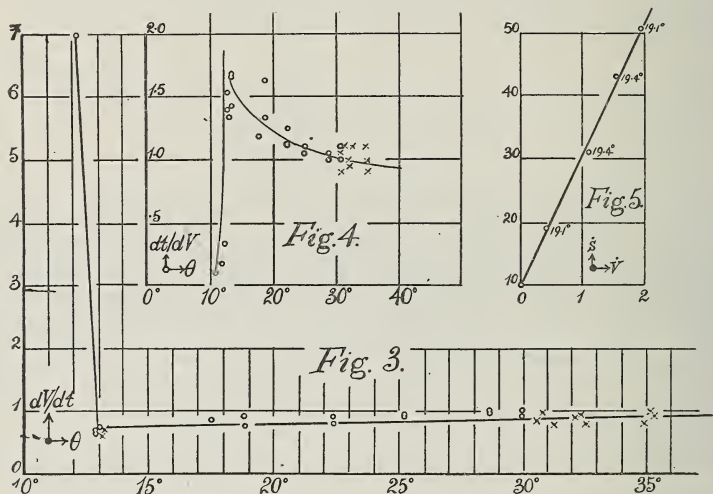

12. *Contrast with the color data.*—The character of these curves may now be examined in comparison with the color data of figures 3 and 4, the latter being specially available. In both there is a rise of activity from about 9° through a maximum, and an eventual less pronounced decline of activity toward 35° ; but in their details, the two sets of curves are very different. The nuclei of figure 3 are suddenly produced in maximum concentration at about 13° C., as suggested by the arrows *c* in figure 6 et seq.; they then decline in number regularly and very gradually as far as observed. In figure 6, however, the ions show a gradual increase of number, even as far as 20° , after which their number also falls off to the limits of observation.

One may argue, therefore, that the nuclei as first produced are but weakly ionized in spite of their maximum condensational activity. As temperature rises, the latter property of the nucleus declines, but the ionization increases as far as about 20° . Thereafter both properties decline. As the number of nuclei decreases from the reaction at 13° onward with increasing temperature, one may infer that the ionization increases with temperature; from another point of view, that the ionization increases as the property of the nucleus to induce condensation diminishes. It is then with the nearly non-ionized nucleus that the maximum of condensational activity resides, just as if ionization were the result of a dissociation or a disaggregation of the nucleus.

13. *Electrical experiments repeated.*—It is doubtful whether the color experiments can be much improved. These results are bound to lack sharpness; but the electrical experiments are open to further development in the first place by retaining a constant velocity dV/dt throughout. This may be done by inserting a second stopcock, F' (not shown), to check the air current to a fixed value, even when F , figure 1, is quite open. In the second place the weakly ionized emanation at low temperatures should be tested directly as to its condensational power. One may inquire whether the reduced condensing power of the positive and the negative ionizations differ; whether at a given temperature definite ionization is obtainable quantitatively, etc.

In Table III results obtained by the same method as above are summarized for brevity. The volumes, dV/dt (liters/min.), of air charged with phosphorus emanation traversing the condenser, are a nearly constant quantity in view of the second stopcock already mentioned. θ is the temperature at which the fall of potential, ds/dt , was observed, s being the deflection in scale parts of the electrometer used above. The condenser was given a positive and a negative charge alternately, with the outer face put to earth. Four readings for the negative charge were included between similar sets for the positive charge. The conduction of the insulators is given. The last column contains the datum $x = -(ds/dt)_0/s_0$.

14. *Discussion.*—The initial currents (x) are shown in the graph, figure 7. As a whole the results are much more definite than in figure 6, seeing that no reduction for volume differences is now needed. Though there is a small difference between the currents corresponding to the positive and the negative charges, this difference lies within a scale part and may be taken as an error of observation. The position of the maximum of nuclei is again shown at c . The range of the new data after deducting the error in insulation is smaller than

TABLE III.—Radial currents in the condenser. Phosphorus ionizer at different temperatures. $E_0 = 41$ volts. $s_0 = 73$.

θ , etc.	dV/dt	ds/dt	s_0/s_0
Insulation	·00	3·6	·05
14·0°	·48	— 5·5	+·07
14·0	·49	— 6·0	—·08
16·4	·48	+13·3	+·18
16·4	·48	—14·0	—·19
19·8	·48	+18·0	+·25
19·8	·48	—18·0	—·25
22·8	·48	+16·5	+·23
22·8	·48	—17·0	—·23
26·6	·48	+15·5	+·21
26·5	·47	—15·0	—·21
30·7	·48	+13·8	+·19
30·7	·47	—14·5	—·20
34·9	·48	+12·8	+·18
34·8	·48	—13·0	—·18

above, a circumstance presently to be considered and attributable to moisture and leakage errors, or in general to the necessarily unsaturated condition of the ionization within the condenser.

Moreover the form of figure 7 differs from figure 6 and has approached more nearly to the color results of figure 4. The maximum, however, is still near 20°, so that the inferences above on the earlier appearance of the nuclei, is sustained.

15. *Permanent conduction produced by the emanation.*—At this stage of my work, I encountered a peculiar and puzzling series of phenomena which were not noticed in my earlier work, probably because the room temperature was purposely kept high and the atmosphere dry. After the air was passed over phosphorus freshly put into the tube *ab*, figure 1, the condenser receiving the emanation was thereafter found to remain *permanently conducting* even with the air current shut off, precisely as though it had itself become radio-active. This conduction was relatively so enormous that the electric currents could not be measured by the same electrometer and the occurrence of an internal metallic contact or break in the insulation was immediately suggested. I, therefore, overhauled the condenser carefully, inserted an internal bushing, replaced the internal rod by a new one, etc., all without effect. The condenser showed good insulation after putting it together, but became a conductor after the passage of the first phos-

phorus emanation. Permanent leakage due to dislocation of the solid parts was thus out of the question.

This conduction vanished over night. It was reproduced as soon as fresh phosphorus air passed through the condenser. It then remained permanent though gradually diminishing for hours, and was nearly gone again next day. Hence two causes are suggested: either a film of residual moisture aspirated off from the phosphorus grid (which however was as usual carefully dried by squeezing in a press between folds of blotting paper, and then exposed to the air, so that only traces of moisture can be in question) was precipitated in the condenser to the detriment of the hard rubber insulation; or else some form of emanation given off from the phosphorus made the condenser radio active. Incidentally I may advert to the extreme caution needed before such radio-activity can be assumed, the behavior in both cases being essentially alike.

Warming the condenser seemed to be useless. Moderate amounts of dry air (say 7 liters flowing out in about 10 minutes) passing over the phosphorus were nearly ineffective. It was no remedy to remove the phosphorus and pass dry air alone in the forward direction. Separating the condenser from the water bath did not change its conduction. Thus I found, for instance, for the condenser alone and free from air current, $ds/dt = 33$; an hour later, $ds/dt = 25$; next day $ds/dt = 7$; good insulation, $ds/dt = 2$.

At $\theta = 30^\circ$ (water bath temperature), the tendency of the condenser to conduct permanently was at first accentuated but soon completely wiped out. The electric current reached a normal value. This appeared so much like a moisture error that I further tested it by passing the air current backwards, through the condenser first and then over the phosphorus into the atmosphere, in this way drying both parts. Insulation of the condenser was thus at once restored. Again on passing a considerable volume of dry air (say 15 liters, slowly) over the phosphorus, this too lost its power to make the condenser permanently conducting. Hence in the experiments of the following table the phosphorus was first dried in this way in a current of dry air. The work then progressed smoothly, showing the relation of the emanating activity of phosphorus to temperature in a new light.

I may add again that in none of my earlier experiments were like discrepancies encountered. Possibly a corroded copper grid may be hygroscopic, something like platinum black.

16. *Specially dried phosphorus grids.*—In Table IV, θ is the temperature of the water bath, dV/dt the volume of dry air in liters passed per minute over the phosphorus: ds/dt is

the corresponding initial radial electric current in the condenser in arbitrary units, when the potential difference, E_0 , is about 40 volts and the initial deflection, s_0 , as stated. In both cases the insulation of the condenser in the absence of the air current, is measured for each temperature. This is then deducted and the corrected electrical currents tabulated. In Table IV, on the left, a channeled hard rubber bushing guards (unnecessarily as it afterwards proved) against metallic contact of the core and envelope. In the data on the right this has been removed. The phosphorus in both cases is dried preliminarily, as stated, by a current of dry air from the desiccator, entering the condenser first and passing thence over the phosphorus grid into the atmosphere. The last columns give the currents $(ds/dt)_0/s_0 = i_0/s_0 = i_0/Q_0$, supposing that initially $Q = Q_0 e^{-\alpha(t-t_0)}$ as stated in §11.

TABLE IV.—Ionizing activity of dried phosphorus. $E_0 = 41$ volts. $s_0 = 73.5$.
 $dV/dt = .52$ liters/min.

θ	ds/dt	\dot{s}_0/s_0	θ	ds/dt	\dot{s}_0/s_0
19.2°	6	.09	25.8°	7	.10
18.0	4	.06	21.2	7	.10
16.5	4	.05	20.0	9	.12
15.0	0	.00	18.8	9	.12
			17.8	8	.12
16.8	6	.08	16.6	8	.11
18.2	11	.15	15.5	6	.08
19.2	13	.18	14.0	2	.03
20.6	13	.18	13.3	1	.91
22.4	12	.16	Color experiments made at 13.5° (here) showed blue equivalent to .8 lit./min. After the color experi- ments, for $dV/dt = .93$ lit/min. results were as follows:		
27.2	10	.14			
33.8	9	.12			
Channeled hard rubber bush- ing in condenser.			14.0	4	.06
			14.0	4	.06
			Bushing removed.		

17. *Discussion.*—The results of Table IV are shown graphically in figures 8 and 9, where the currents $(ds/dt)_0/s_0$ are as usual the ordinates. In a general way the character of figures 6 and 7 has been preserved, inasmuch as there is maximum ionization at about 20°: but the details of behavior are again different. In the first place the scale of the phenomenon is gradually reduced as the emanating body is repeatedly subject to desiccation. This merely means deficient phosphorus surface, as I take it.

There is no certain tendency of the maximum to move into smaller temperatures in the later experiments. Thus when $dV/dt = \cdot 50$, nearly,

Figure 6,	maximum $(ds/dt)_0/s_0 = \cdot 20$ at 20°
Figure 7,	= $\cdot 20$ 19°
Figure 8,	= $\cdot 18$ 20°
Figure 9,	= $\cdot 12$ 19° .

Whether the phosphorus is being actually consumed, or

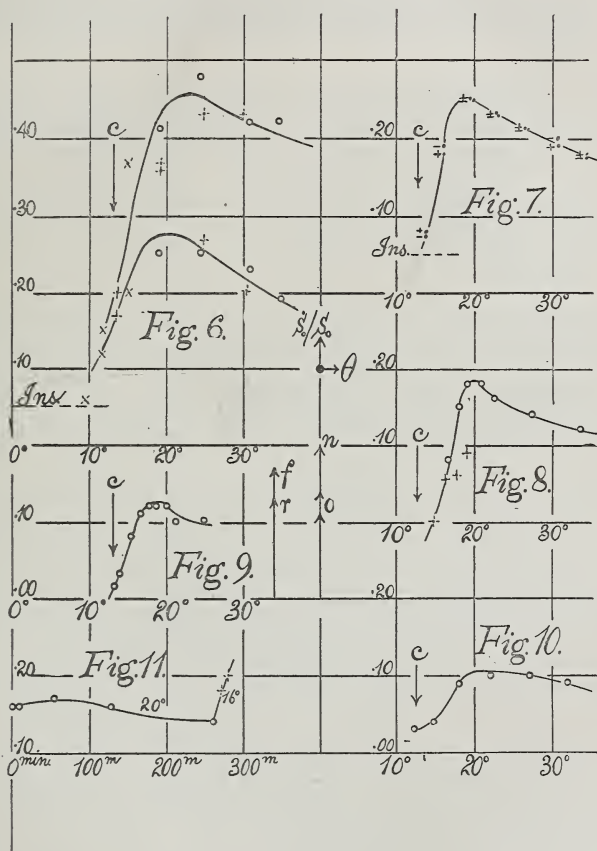

whether merely a superficial change is in question will be investigated below; but the charged air current is gradually further removed from saturation and will continue on the decline in the following experiments. Moreover here is an explanation of the differences of slope shown in the volu-

metric and electrical curves of an earlier paper (l. c.). For the degree of "dryness" reached wholly determines the electrical curve without in the same degree influencing the volume curves, as will presently be further manifest.

In all cases the dependence of the electrical results on temperature remains quite different from the corresponding dependence of the color data on temperature. Special experiments made at the end of Table IV with identical apparatus showed strong color activity at 13.6° , viz: blue corresponding to $.80 \text{ lit/min.}$ while the subsequent electrical measurements at 14° (see Table VI) reproduced the original exceptionally low conductions.

The position of the phosphorus grid in the tube, ab , of the water bath, figure 1, showed an effect insufficient to be of moment in relation to the phenomena under discussion. Thus

Rear position, furthest from end a and condenser, $(ds/dt)_0/s_0 = .13$
(see r , figure 9).

Front position, nearest to condenser, $(ds/dt)_0/s_0 = .17$ (see f , figure 9).

Nevertheless there is nearly one-third more saturation when the phosphorus grid is nearest the condenser than when remote, a circumstance which, as already intimated, makes it difficult to investigate saturation in this way. Any connecting tube between ionizer and condenser is an absorber, particularly if bent.

18. *Corroborative experiments with the color tube.*—A series of experiments were now begun with the steam jet, to ascertain the difference between the character of the emanation immediately after the phosphorus grid has been prepared (without preliminary desiccation) and after a large volume of dry air (20 to 30 liters) has been passed over it. If the relatively enormous currents obtained in the condenser in the first instance are due to nuclei, there must be a corresponding result in the volume per minute of the saturated emanation necessary to produce a fixed color (blue) in the color tube. The reverse is the case, as will be seen in Table V, where nuclei and ion production are in a measure reciprocal occurrences. In other words, the initial enormous conductions are accompanied by an abstraction of nuclei.

Three phosphorus strips were as usual dried in press between folds of bibulous paper and then exposed to air for some time. They were then inserted into the tube, ab , of the water bath, figure 1. The initial (apparent) ionization as tested by the condenser was invariably too intense to be measurable. The condenser was then removed and a short tube, G , added to

obviate excessive absorption before discharging into the color tube.

In Table V, the liters of dry air which have passed over the phosphorus strips are given under *L*. The successive liters of emanation per minute to produce the standard blue are given in the third column (dV/dt); the fourth gives the current (often estimated) when the emanation passes through the condenser at the fixed rate of .5 liter/min., selected for convenience.

TABLE V.—Condensation producing activity of initial “wet” and final “dry” phosphorus emanation. Temperature $\theta = 18^\circ$. $dV/dt = .5$ lit/min., $s_0 = 73$, for condenser.

Color, etc.	<i>L</i>	dV/dt	ds/dt	Remarks.
Insulation	0	0	----	Condenser discharged within 5 ^{sec}
Bl	0	1.70	----	
Bl	6	1.60	----	Condenser discharged within 10 ^{sec}
	13	---	100	Current estimated.
	20	1.43	15	Phosphorus “dry.” Insulation 6
	25	1.40	----	Ionization constant. $\dot{s}_0/s_0 = .21$

Another experiment. Grid scoured. Temperature 21°.

Bl—	0	115	----	Condenser discharged within 7 ^{sec}
	4	---	----	Nuclei insufficient to produce opaque.
Bl	---	100	200	Opaque now attained. Con-
Bl	---	90	----	denser discharged within 20 ^{sec} .
Bl	8	103	----	Current estimated.
Bl	15	90	9	Insulation $ds/dt = 1$, nearly perfect.
Bl	20	90		
Bl	27	100		Ionization constant. $\dot{s}_0/s_0 = .13$

The first part of Table V shows definitely that when the currents are too large to be even estimated, the emanation needed to produce the standard blue is larger than at the end of the experiment, where the radial currents have fallen off to their small fixed value. Thus the high conduction is without nuclear condensing effect.

In the second part of the table the volumes are nearly constant except at the beginning, where it was found impossible to obtain opaque or even full blue, whatever volume is passed through the ionizer. The necessary number of nuclei was not forthcoming. As in the preceding table, however, less than ten liters of air are sufficient to dry the phosphorus into full activity so far as the color is concerned, whereas the conduction still retains abnormally large values.

Another reciprocal relation is shown on the table. dV/dt here happens to be unusually large, so that the phosphorus is

for some reason weak as a nuclei producer. I, therefore, washed and scoured the surface of the grid, obtaining the usual order of values in the second part of the table. On the other hand, the currents in the first part are larger than those of the second part. Here again, therefore, the tendency to produce nuclei reciprocates in intensity with the tendency to produce ions, or better to produce conduction in the condenser. The latter is facilitated by the presence of traces of moisture, but nuclei are not so produced.

19. *Corroborative experiments with damp paper.*—Another method of throwing light on the inquiry will be a comparison of the conduction produced in the condenser by air passing over damp filter paper with the corresponding case of air passing over phosphorus.

The wet paper (omitting the data) behaves in a less intense way something like the phosphorus. The rise of conduction, however, is gradual, the conduction at best moderate and the return of the condenser to the original degree of insulation relatively rapid. With phosphorus, the conduction after the first minute or so has risen to the immeasurably large values and when the air current ceases the condenser shows similar conduction. Much more dry air is needed to dry the condenser and the phosphorus to normal values (fully twice as much as in the preceding case). Eventually the currents also return to the normal, relatively small limit and the insulation of the condenser is nearly perfect again.

Qualitatively the two phenomena run in parallel; quantitatively, they are enormously different. Inasmuch as the paper is obviously wet, whereas the phosphorus grid has been dried short of desiccation, inasmuch as any emanation must behave like a water evaporation, I think that the volatile body is probably of the nature of a hydrophosphide. Some electrically active substance is distilled in the presence of moisture and precipitated in the condenser.

20. *Corroborative experiments with desiccators.*—The final test made to detect the character of the emanation was one of direct desiccation over chloride of calcium, before insertion. The day happened to be damp and the insulation poor. The experiments, however, are none the less definite.

(1) Phosphorus dried in air and inserted into the dried tube of the water bath, *ab*, figure 1; the condenser was at once discharged on passing the air current through it. On removing the phosphorus the condenser showed too large a leakage to admit of the measurement of current. All appurtenances were now dried in a current of dry air and the final insulation determined.

(2) The phosphorus grid having been placed for about 15

minutes in the desiccator was again inserted into the tube, *ab*. The current now obtained was $ds/dt = 37$; the insulation proved to be $ds/dt = 30$. Hence the current due to ionized air was but $ds/dt = 7$, an abnormally small value, indicating the absence of moisture.

The phosphorus grid was once more put in the desiccator for 15 minutes. After replacing it in the water bath the current observed was 40; the insulation 27. Hence the leakage due to ionized air is here $ds/dt = 13$, agreeing with the usual order of ionized values above.

Owing to the unfavorable condition of these experiments, not much definiteness was to be anticipated from them; but they show clearly that the enormous initial emanation from fresh phosphorus is all but wiped out, relatively speaking, after the phosphorus has been dried preliminarily over calcic chloride. Whether in the rigorous absence of all moisture phosphorus would cease to ionize air, remains to be seen. It is also a question whether the desiccation over calcic chloride may not be accompanied by detrimental chemical action, referable to the chloride. At least the following work continues to show that the phosphorus grid repeatedly treated in this way continually loses strength as an ionizer, in spite of the intermediate submersion in water to keep it over night.

21. *Effect of prolonged drying.*—A final attempt was made to see if after continued drying over calcic chloride the ionization would be wiped out altogether. The following table shows this to have been unsuccessful. The room was favorably dry and warm and the leakage errors in the condenser not appreciable. After nearly 5 hours the potency of the ionizer is not diminished (see figure 11). It has rather increased, due possibly to the attraction of traces of moisture even within the permanently dried tube of the apparatus, figure 1. An extra tube of calcic chloride was attached. In a second experiment the temperature effect is tested for this specially dried phosphorus. The corresponding graph is shown in figure 10, and the ionization is weaker than in any earlier experiment. Nevertheless the results show maximum activity in the neighborhood of 20° , though even at 12° the ionization is not quite extinguished. The exceptionally low ionization is not accounted for except as due to deficient phosphorus, the natural result of long continued consumption.

22. *Promiscuous experiments.*—Having investigated the effect of the temperature of the body of phosphorus on its emanation, I next purposed to ascertain the dependence of the emanation itself on temperature. This could be done by surrounding the condenser by a steam jacket (shown in figure 2, *jj*; *s*, *s*, being the influx and efflux pipes) and noting the effect

of the rise of temperature of nearly 100°. After repeated trials, however, I found that the high temperature so far diminished the insulation of the hard rubber bushings of the condenser, that no measurements would be trustworthy. On cooling the condenser, the insulation again became perfect. Quartz insulators suggest themselves as probably alone available.

23. *Comparison of old and new grids.*—Trial was made with freshly cut phosphorus, the grids used in the above work being as much as a year old. The results show a like order of values for both, in spite of the intense fuming of the new grid. Nevertheless the latter is apt to be from two to three times stronger than the old grid. Thus after thoroughly drying the new grid over calcic chloride and testing it at 21.5°, the data were

$$\begin{array}{rcl} dV/dt = & \cdot 42, & (ds/dt)_o/s_o = \cdot 20, \\ & \cdot 43, & = \cdot 20. \end{array}$$

Exposure to the air of the room for about half an hour after desiccation was without effect.

This experiment proves that the air in all the earlier experiments was undersaturated, agreeing with an earlier paper (l. c) from which values are quoted in the next paragraph.

24. *Older data compared with the present data.*—It is finally worth while to adduce the corresponding data, Table VI, of an earlier paper. The equivalent colors of the steam tube are the yellows and crimsons of the second order. The temperatures are 20°–30°.

TABLE VI.—Relevant data from earlier papers, $E_0 = 40$ volts.

Color.	Temperature, θ .	$10^2 \times dV/dt$	$10^2 \times (ds/dt)_o/s_o$
Yellow ₂	30°	50	16
Yellow ₂	30	65	17
Crimson ₂	30	43	11
Yellow-green ₂	21	50	13
Yellow ₂	24	58	22
Crimson ₂	24	42	14

Clearly then, for $dV/dt = \cdot 43$, nearly, the order of values for the currents is the same here (the experiments made over a year ago but with the same grids) as in the above experiments. The room being very hot insured dryness in that work without preliminary desiccation. Large volumes of dry air were passed over the grids, moreover, for colors of the first order were principally observed, requiring even as much as 3 liters/min. per observation.

The arrows (*n*, new and *o*, old) in figure 9 show the relation of the results in the last table to the values for freshly cut phosphorus in excess given at the beginning of paragraph 23.

Since from the old values the number of nuclei was computed as $n = 2 \times 10^4$, the new values would make them approach $n = 4 \times 10^4$, the datum found with plate and with spherical condensers by entirely different methods, remembering that from the occurrence of an absorbing influx pipe, the air within the tubular condenser can nowhere be quite saturated.

Experiments on the maximum number of nuclei per cubic centimeter producible by phosphorus under favorable conditions, were made at some length; but as they yielded no new results beyond those of § 23, they need not be instanced here.

25. *Conclusion and summary.*—The experiments with phosphorus show that nuclei adapted to condense atmospheric moisture are produced most abundantly at about 13°C . Below this, the rate of production decreases with enormous rapidity (just short of suddenness), probably ceasing at about 8° . This holds true for very different velocities of the dry air passing over the phosphorus. Above the reaction temperature, the activity decreases slowly as temperature rises, having not decreased more than 25 per cent at 35° . Since the phosphorus is superficially heated by the reaction, sharp statements are out of the question.

Below 13° , the opaques of the color series are absent and the maximum tints are fainter and of increasingly higher orders. The strongest permanent color may be approached by very gradually increasing the charged air current. A limiting velocity decreasing with temperature may thus be reached, beyond which all colors vanish and the reaction is quite "blown out," as it were. Suddenly opening the stopcock after a period of quiescence shows puffs of color under these conditions, which also vanish as temperature decreases below 13° . Putting $N = kn$, where N is the number of particles generated per second per superficial square centimeter of phosphorus, n the number per cubic centimeter of the ionized medium, k their (average) velocity in any cardinal direction, the variation of N is to be ascribed to n , k being relatively constant.

In contrast with the color data (nuclei), the ionization of air passing over phosphorus increases with temperature to a maximum at about 20° , after which there is a less pronounced decline. This ionization is not an arrival comparable in suddenness with the appearance of nuclei, nor are the maxima identical as to temperature. One may infer that the nuclei as first produced are weak in ionization but of normal strength in condensational activity; that thereafter the latter property declines because (probably) the ionization increases as far as 20° . Finally both properties decline. This reciprocity is accounted for if the ionization is a result of the dissociation of

nuclei. The degree of ionization is here independent of the sign of the charge.

If the phosphorus grid is not preliminarily quite dry, traces of moisture are apt to escape with the emanation and produce permanent conduction in the condenser. Considerable variation of the electrical coefficients may thus ensue, though the color results are, relatively speaking, but slightly affected. As the electrical discrepancy seems to be out of proportion with the quantity of moisture present, it is probable that the emanation escapes in some combination with it. The whole phenomenon vanishes on thorough desiccation both of the phosphorus and the apparatus. Grids frequently treated in this way show a gradually decreasing ionizing intensity, probably due to the continued consumption of phosphorus or to a removal of effective surface. Throughout the experiments the relation of the color curves to the electrical curves remains practically unchanged, in spite of the different degrees of saturation (ionization).

The relatively enormous conductions associated with non-desiccated phosphorus are without a color effect when tried in the steam tube. They rather give evidence of an abstraction of nuclei. Moreover such reciprocal properties are manifest in other instances. § 18. Air passed over damp paper behaves similarly to the emanation from non-desiccated phosphorus, with a difference of intensity in favor of the latter. Desiccation over calcic chloride removes the incidental conduction entirely. The emanation may thus be dried to a limiting degree of ionization which is not then further reduced on drying. In practice all operations should be made with desiccated phosphorus; otherwise the baffling discrepancies encountered in the case of plate and spherical condensers may be anticipated.

By using freshly cut fuming phosphorus in excess in the ionizer, it was possible to increase the radial currents in the condenser to nearly twice their usual value, remembering that the emanation within the condenser is in all parts essentially unsaturated. Hence the low concentrations formerly found for tubular condensers (2×10^4 nuclei per cubic centimeter) is made to approach the value found from plate and spherical condensers (4×10^4), more nearly.

Brown University, Providence, R. I.

ART. XXXVI.—*On the Determination of the Heat of Dissociation and of Combustion of Acetylene, Ethylene and Methane;*
by W. G. MIXTER.

[Contributions from the Sheffield Laboratory of Yale University.]

THE heat of formation of an organic compound is deduced, as is well known, from its heat of combustion and that of its constituents, since it is impossible to form any hydrocarbon under conditions at which the thermal effect may be measured. The determination of the heat evolved when acetylene is

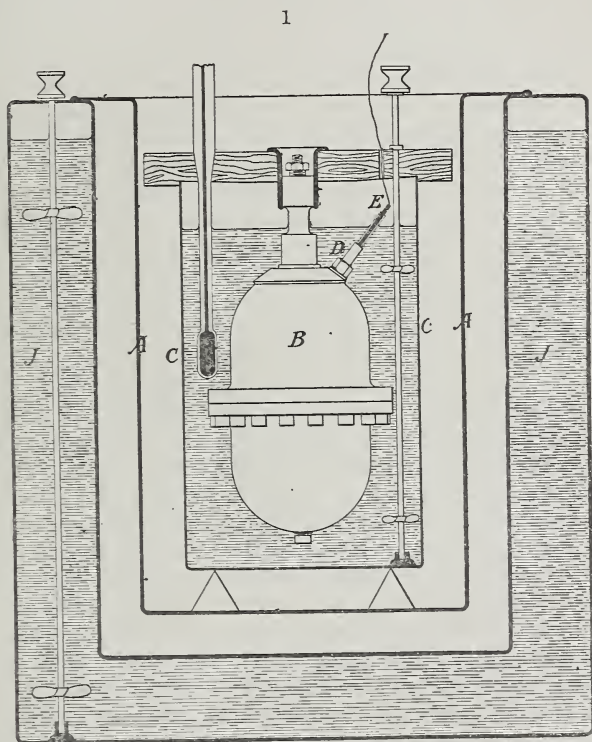

decomposed is, however, one of the easiest of calorimetric experiments, giving at once the heat of combination, as the thermal change of dissociation equals that of combination. Moreover, it is probable that the direct measurement of the change is less liable to error than the indirect method, which involves burning the gas. The thermal effect of the dissociation of other hydrocarbon gases may be found by mixing them

with sufficient acetylene to effect when exploded complete decomposition. The heat found less than due to the acetylene equals the heat of dissociation of the compound. The method is open to the objection that the errors are cumulative.

The apparatus used in the work is shown in fig. 1. The outer double-walled vessel, J, J, called for convenience the jacket, contains 20 liters of water, which may be stirred before an experiment by the screw propellers. The tin vessel, A, A, separates the calorimeter from the jacket by two air spaces. The calorimeter vessel is tinned iron. The top of it was imperfectly covered by a thin sheet of celluloid and was exposed to the air of the room. The steel bomb B has a capacity of 602^{cc}, weighs about 1900 grams, and is supported by a bar of wood resting on the top of the calorimeter case. It was silver-plated to prevent rusting and the silver on the interior surface was covered with a thin plating of gold. After the explosions of acetylene the inside plating showed minute perforations with projecting edges, owing doubtless to enclosed particles of plating solution which gave off steam when heated, as electro-plate is known to shut in minute particles of solution which are not removed by washing or drying. The explosions of a mixture of acetylene or ethylene and oxygen dulled the surface of the gold and gradually removed the metal in the state of fine powder. The explosions of acetylene were noiseless, while those of mixtures of oxygen gave a distinct report, threw the water against the cover and loosened the screws at the top and bottom of the bomb. Ignition was attained by electric sparks between a strip of platinum foil connected with the bomb and a platinum wire, E, insulated by a piece of clay pipe stem projecting into the bomb and a glass tube in the steel tube, D. The foil was commonly melted and the wire, which was 1½^{mm} thick and extended into the bomb several millimeters, was bent by the detonations of acetylene and oxygen. The mean of five accordant calorimetric determinations of the water equivalent of the bomb and calorimeter can was 250 grams. The error is probably too small to affect the results in the fourth figure, since the weight of the apparatus times the specific heat of iron is 262 with no allowance for the small amounts of other metals present. Upon changing a fitting on the bomb the number 252 was adopted. A differential thermometer graduated to hundredths of a degree was used. It was found to agree with a normal thermometer and one graduated to tenths. The zero of the differential thermometer was not changed during the work and corresponded to 16.4° of the normal.

In none of the experiments was any measurable quantity of acetylene found in the gas remaining after an explosion and in

most of them not a trace was detected. The pressures used were higher than those at which the gas was exploded in earlier experiments,* when several per cent of acetylene was found after exploding. Whether the different result in this respect is due solely to pressure or to other causes, the writer has not had time to investigate. In order to find if the acetylene decomposed in the calorimetric bomb without formation of hydrocarbons, the following tests were made. The gas in the bomb after an explosion was passed through a solution of potassium hydroxide to remove hydrocyanic acid and then burned. No carbon dioxide was revealed by lime water. 2.4 grams of carbon from the acetylene exploded in the bomb were heated in a combustion tube through which a current of dry air was passed to remove moisture. The combustion was then made in the ordinary way with oxygen and copper oxide. The result was 0.016 per cent of hydrogen. This amount may be due to the error of the analysis. These results show that in the calorimetric experiments the acetylene decomposed completely into hydrogen and carbon.

The composition of each sample of gas used was determined, and the amount taken was calculated from the capacity of the bomb or was found by weighing the bomb before and after filling: when hydrocyanic acid was estimated in the residual gas an equivalent quantity of acetylene was deducted from that taken. As a rule, the description of the many details involved in finding the amount of gas used for an experiment are omitted. Since the accurate determination of differences in temperature is the most difficult problem in calorimetry, the observations are stated in detail. The water in the calorimeter was stirred by the small screw propellers shown in the figure, driven by a motor. The observations of temperature were recorded at intervals of three minutes, and that noted immediately before explosion is taken for the initial temperature, no correction being made for slight changes preceding. The final temperature assumed is that observed the sixth minute after explosion plus five-sixths the average fall in temperature for a subsequent six minutes. The reason for not allowing for loss of heat during the first minute is this: the water of the calorimeter did not attain the maximum temperature observed until one, two or sometimes three minutes after the explosion, and it is less accurate to consider that as much heat is lost by the calorimeter in the six minutes immediately following explosion as in the next six. It is possible the corrections made are excessive, but any error in this respect is small as the correction in but a few instances amounted to one per cent, and in most of the experiments it was less than half as much.

* This Journal, ix, 1, 1900.

The results are given for gram molecules and 1 and 12 are taken for the atomic weights of hydrogen and carbon respectively. No corrections are made for water vapor or nitric acid remaining after explosion, as these would only change the sixth figure of the results.

Acetylene.

The acetylene gas was made by thrusting lumps of calcium carbide into water in a glass gas holder. By means of ferrous hydroxide it was freed from traces of oxygen. Thus prepared the gas contained from 1 to 3 per cent of nitrogen. It was dried before pumping into the bomb by passing it through a kilo of small sticks of potassium hydroxide. The oxygen used was made from chlorate and was kept over water containing a little sodium hydroxide.

Experiment 1.—Acetylene, 7.24 grams, gave too great a rise of temperature to be measured by the differential thermometer. Accordingly the thermometer graduated to tenths of a degree was used in the calorimeter. The result was 51,900 calories for 26 grams of acetylene.

Experiment 2.—Acetylene, 5.488 grams; temperature of jacket 2.7° by the differential thermometer used in the calorimeter. The residual gas was free from acetylene.

Minutes.	Temperature.	
0	0.285	Water in calorimeter, 3000 grams.
3	0.290	Water equivalent of
6	0.295	calorimeter, 250 "
9	3.740	—————
12	3.730	3250 "
15	3.709	Temperature interval,
18	3.696	$3.73 - 0.295 + 0.027 = 3.462^{\circ}$
21	3.682	

Multiplying this temperature interval by 3,250 and by the ratio of 26 to the mass of the substance taken we deduce for 26 grams of acetylene 53,300°.

Experiment 3.—In this experiment the bomb leaked after charging with acetylene. Hence it is better not to record the calorimetric result although it accorded fairly with the other.

Experiment 4.—Acetylene, 6.493 grams; jacket, 3.4° . The residual gas did not contain acetylene.

Minutes.	Temperature.	
0	0.0	Water and water equivalent of
3	0.01	calorimeter, 3250 grams.
6	0.02	
9	0.027	Temperature interval,
12	4.110	$4.114 - 0.027 + 0.018 = 4.105^{\circ}$
15	4.114	

Minutes.	Temperature.
18	4.100
21	4.090
24	4.080
27	4.070

Reducing as before the resulting value is 53,400°.

Experiment 5.—Acetylene, 5.3829 grams; jacket, 4; room, 4.5°. The residual gas contained too small a quantity of acetylene to measure.

Minutes.	Temperature.	
0	0.45	Water and water equivalent of calorimeter, 3250 grams.
3	0.47	
6	0.49	
9	0.51	
12	3.892	Temperature interval, 3.887 - 0.51 + 0.007 = 3.384°
15	3.887	
18	3.880	
21	3.875	
24	3.875	
27	3.870	
30	3.865	

The resulting value is 53,200°.

Experiment 6.—Acetylene, 4.043 grams; jacket, 3.6°. The residual gas was free from acetylene.

Minutes.	Temperature.	
0	1.05	Water and water equivalent of calorimeter, 3252 grams.
3	1.07	
6	1.083	
9	1.097	Temperature interval, 3.645 - 1.097 + 0.004 = 2.552°
12	3.649	
15	3.645	
18	3.642	
21	3.640	

The resulting value is 53,300°.

Omitting experiments 1 and 3, the following are the results of the determinations of the heat evolved on exploding acetylene:

53,300
53,400
53,200
53,300

The average is 53,300° for 26 grams and 2050° for 1 gram of acetylene.

Experiment 7.—The bomb with a capacity of 602^{cc} was filled with dry gas (97.4 per cent by volume of acetylene) at 20.7° and 756^{mm}. The calculated weight of this volume of acetylene

352 *Mixer—Determination of the Heat of Dissociation.*

is 0.6342 gram. Rather more dry oxygen was added than required for complete combustion.

Minutes.	Temperature.	
0	0.935	Water and water equivalent of calorimeter, 3252 grams.
3	0.948	
6	0.950	
9	3.270	Temperature interval, $3.264 - 0.95 + 0.007 = 2.321^\circ$
12	3.264	
15	3.260	
18	3.254	
21	3.250	

The resulting value is 309,400°.

Experiment 8.—The bomb filled as before contained 0.6527 gram of acetylene. Jacket 1.6°.

Minutes.	Temperature.	
0	0.340	Water and water equivalent of calorimeter, 3252 grams.
3	0.350	
6	0.360	
9	2.750	Temperature interval, $2.762 - 0.36 + 0.007 = 2.409^\circ$
12	2.762	
15	2.760	
18	2.756	
21	2.750	
24	2.743	

The resulting value is 312,100°.

Experiment 9.—The bomb was filled as for experiments 7 and 8 with dry oxygen and acetylene and contained 0.6456 gram of the latter gas. Jacket, 2.6°.

Minutes.	Temperature.	
0	1.109	Water and water equivalent of calorimeter, 3252 grams.
3	1.111	
6	1.113	
9	3.502	Temperature interval, $3.5 - 1.113 + 0.012 = 2.399^\circ$
12	3.500	
15	3.490	
18	3.482	
21	3.476	
24	3.470	

The resulting value is 313,700°.

The mean of the three determinations of the heat of combustion of acetylene is 311,700° and of the last two it is 312,900° at constant volume and 313,800° at constant pressure.

Before discussing the foregoing results reference must be made to the heats of combustion of hydrogen and amorphous

carbon. Thomsen* made three determinations of the heat of combustion of hydrogen in which 18,928 grams of water were produced, and obtained as the mean 68,357°. Berthelot and Matignon† adopt as the results of their experiments the number 69,000. Thomsen‡ used the number 96,960 for CO₂ obtained by Farve and Silbermann,§ and Berthelot|| found 97,650°. Thomsen, and Farve and Silbermann made the combustion slowly at atmospheric pressure, while Berthelot made them almost instantly in his bomb. The former worked with large quantities and the latter with small, in case of hydrogen with about 23 milligrams. Berthelot's results are somewhat higher than the others. The sum of the heats of combustion of the components of acetylene is, according to Thomsen, 262,277°, to Berthelot 264,300°. The former¶ found for the combustion of acetylene 310,050° and the latter** 315,700° at constant pressure. The writer's result is 313,800°. Thomsen made the heat of formation of acetylene -47,770°. If we calculated it from Berthelot's figures it is -51,400°.

Ethylene.

The ethylene gas was prepared by the action of zinc on pure ethylene bromide dissolved in alcohol. It was freed from oxygen by ferrous hydroxide but contained several per cent of hydrogen gas and doubtless a little nitrogen. It was dried by sulphuric acid.

Experiment 10.—Gas containing 93.7 per cent by volume of ethylene, 602° at 18.5° and 748^{mm} pressure equal to 0.655 gram of ethylene; acetylene added 4.828 grams; jacket 1.4°. The gas after explosion was free from hydrocarbons.

Minutes.	Temperature.	
0	1.22	Water and water equivalent of calorimeter, 3252 grams.
3	1.22	
6	1.22	
9	4.329	Temperature interval, 4.362 - 1.22 + 0.026 = 3.168°
12	4.362	
15	4.343	
18	4.330	
21	4.314	
24	4.300	

The thermal result is 10,300°.

The heat of dissociation of 4.828 grams of acetylene is 9,900 calories; subtracting this from 10,300 we have 400 calories

* Thermochemische Untersuchungen, ii, 52. † Ann. Ch. Phys. [6], xxx, 553.

‡ Thermochemische Untersuchungen, ii, 283. § Ann. Ch. Phys. [3], xxxiv, 357.

|| Ann. Ch. Phys. [6], xviii, 89. ¶ Thermochemische Untersuchungen, vi, 74.

** Ann. Ch. Phys. [6], xxx, 556

due to the 0.655 gram of ethylene. These data give 17,000 calories for the heat of dissociation of 28 grams of ethylene.

Experiment 11.—The mixed gases used contained 0.707 gram of ethylene and 4.091 grams of acetylene. The gas after explosion was freed from hydrocarbons. Jacket, 1.6°.

Minutes.	Temperature.	
0	1.88	Water and water equivalent of calorimeter, 3252 grams.
3	1.88	
6	1.88	
9	4.618	Temperature interval, $4.581 - 1.88 + 0.025 = 2.726^\circ$
12	4.581	
15	4.568	
18	4.550	
21	4.534	
24	4.520	

These data give 18,900° for the heat of dissociation of ethylene.

Experiment 12.—The bomb contained 1.952 gram of ethylene and 5.045 grams of acetylene. The gas after explosion was free from hydrocarbons. Jacket, 0°; room, 0.35°.

Minutes.	Temperature.	
0	0.470	Water ----- 3200
3	0.470	Water eq. of calorimeter, 252
6	0.470	-----
9	3.690	3452 grams.
12	3.660	Temperature interval, $3.66 - 0.47 + 0.032 = 3.222^\circ$
14	3.649	
17	3.628	
20	3.604	
23	3.587	
26	3.569	$3452 \cdot 3.222 = 11,122$ calories.
29	3.550	

From these data we deduce for the heat of dissociation of 28 grams of ethylene 11,200° at constant volume and 10,600° at constant pressure. This result is probably the best of the three because about three times as much ethylene was taken as in the two preceding experiments.

Experiment 13.—The gas used contained 93.7 per cent by volume of ethylene. Hydrogen was assumed to constitute the remainder, as it was found after removing ethylene. The bomb contained 602^{cc} of the dry gas at 15.5° and 755.5^{mm} pressure. The calculated amounts are 0.669 gram of ethylene and 0.0032 gram of hydrogen. 3.2 grams of oxygen were added. Jacket, 1.5°.

Minutes.	Temperature.	
0	0.239	Water and water equivalent of calorimeter, 3252 grams.
3	0.240	
6	0.240	
9	2.801	Temperature interval,
12	2.783	$2.783 - 0.24 + 0.024 = 2.567^\circ$
15	2.769	
18	2.753	
21	2.739	
24	2.724	
		$3252 \cdot 2.567 = 8348^\circ$
		Deduct for hydrogen 109°
		8239°

and for 28 grams of ethylene, 344,800°

The bomb leaked at the valve after exploding in 14th experiment. The result was 340,400 calories.

Experiment 15.—602^{cc} of gas (97.2 per cent ethylene) at 21.6° and 762^{mm} pressure, containing 0.685 gram of ethylene, was mixed with the excess of oxygen. Jacket, 3°; room, 5°.

Minutes.	Temperature.	
0	1.813	Water and water equivalent of calorimeter, 3252 grams.
3	1.824	
6	1.835	
9	4.410	Temperature interval,
12	4.410	$4.41 - 1.835 + 0.007 = 2.582^\circ$
15	4.400	
18	4.400	
21	4.394	
24	4.393	

The heat of combustion of 28 grams of ethylene from these data is 343,400°.

Experiment 16.—602^{cc} of gas (97 per cent C₂H₄) saturated with water vapor at 19.4° and 760.4^{mm}, containing 0.67 gram of ethylene, was exploded with an excess of oxygen.

Minutes.	Temperature.	
0	0.857	Water and water equivalent of calorimeter, 3252 grams.
3	0.860	
6	0.860	
9	3.398	Temperature interval,
12	3.394	$3.394 - 0.860 + 0.012 = 2.546^\circ$
15	3.389	
18	3.380	
21	3.388	
24	3.370	
27	3.360	
30	3.351	

From these data we have 345,700°.

The results of the combustion of ethylene, omitting experiment 14, are

Experiment 13	344,800
“ 15	343,400
“ 16	345,700

An average of 344,600 calories at constant volume and 345,800 at constant pressure. Although the results agree well they may be slightly in excess owing to a possible oxidation of the bomb. There was, however, no rust where the steel was exposed and the fine powder washed out of the bomb after an explosion was mostly gold and was nearly free from iron. Thomsen* obtained for the combustion of ethylene 333,350° and Berthelot† 341,100° at constant pressure. In deriving the heat of formation we have the difficulty already mentioned regarding the choice of the numbers to be taken for the heats of combustion of the constituents of ethylene. According to Thomsen (*loc. cit.*) it is -2710°, and using Berthelot's figures we have -7800° for the formation of ethylene from hydrogen and amorphous carbon. If, however, we deduct 341·100 (B) from 330·600, the heat of the combustion of the constituents of ethylene adopted by Thomsen, we have -10,500°. The writer's direct determinations of the heat of dissociation of ethylene vary too widely to have much significance, but they indicate that ethylene may be more endothermic than has been assumed.

Methane.

The methane was made in the usual way by heating a mixture of sodium acetate and soda-lime, and also of the acetate and barium hydroxide, and the two products were united. The gas was purified by passing it slowly through fuming sulphuric acid and then allowing it to stand over water containing ferrous hydroxide. A combustion of the gas gave 0·677 gram of CO₂ and 0·572 gram of water, corresponding to 93·8 volumes of methane and 6·2 volumes of hydrogen. The gas was fairly free from nitrogen.

Experiment 17.—The bomb contained 1·18 gram of methane, 4·765 grams of acetylene and 0·061 gram of hydrogen and nitrogen. Jacket, 1·4°; room, 0°. The gas left after exploding gave no carbon dioxide when burned.

Minutes.	Temperature,	
0	1·034	Water and water equivalent of calorimeter, 3252 grams.
3	1·034	
6	1·034	
9	3·589	Temperature interval,
12	3·578	3·578 - 1·034 + 0·023 = 2·567°

* Thermochemische Untersuchungen, iv, 65. † *Ann. Ch. Phys.* [6], xxx, 557.

Minutes.	Temperature.
16	3·559
19	3·544
22	3·530
28	3·517

The experimental result is 8348°: subtracting this number from the thermal effect of the acetylene taken, which is 9768°, we have 1420° required to dissociate 1·18 gram of methane and for 16 grams 19,300° at constant volume.

Experiment 18.—Methane 1·431 gram, acetylene 5·467 grams and hydrogen and nitrogen 0·063 gram. The gas after the explosion contained no acetylene, but gave a little carbon dioxide when burned. Apparently some methane was not decomposed. The jacket and room were 0·7° according to the differential thermometer.

Minutes.	Temperature.	
0	0·36	Water and water equivalent of calorimeter, 3252 grams.
3	0·36	
6	0·36	Temperature interval, $3·273 - 0·36 + 0·023 = 2·936^\circ$
9	3·28	
12	3·273	
15	3·260	
18	3·245	
21	3·230	

The result calculated as before is 18,700°.

The mean of the two results with methane is 19,000° volume constant and 18,420° pressure constant required to dissociate methane. Thomsen's value of the formation of methane at constant volume is 21,170°. Calculated from Berthelot's data it is 21,500°.

ART. XXXVII.—*The Geological Relations and the Age of the St. Joseph and Potosi Limestones of St. François County, Missouri*; by FRANK S. NASON.

DURING the months of March and April, 1901, the writer was engaged in some engineering work for the Derby Lead Co. of St. François county. The nature of the work necessitated a study of the local geology. Incidentally this led to the exact determinations of the relations existing between the underlying St. Joseph, or Bonne Terre, and the overlying Potosi, as well as the age of the two limestones.

The writer is indebted to Mr. O. M. Bilherz, superintendent of the Doe Run mine at Flat river, for first calling his attention to fossils which he had found, and to Mr. Arthur Thacher and Mr. J. T. Morrell, president and superintendent of the Central Lead Co., for the assistance which they tendered him.

The rocks of St. François county have a general, but very slight, S.W. dip. The country is hilly, the higher points reaching from one hundred to one hundred and fifty feet above the datum level of Big and Flat rivers. The hills and ridges are not due, in general, to either monoclinical or anticlinal folds, but, so far as is now known, to erosion entirely. Both Big and Flat rivers have flood plains a mile or more in width, thus cutting through the overlying measures. Into these rivers on either side flow smaller tributary streams which have cut more or less deeply into the long divides, breaking them up into more or less hill-like domes. The gulches formed by these streams are dry and almost wholly denuded of soil, leaving the nearly horizontally bedded rocks exposed. As the summits of these hills are approached the mantle of residuary clay becomes thicker and on the summits of many of the hills this clay, filled with drusy, cherty quartz, is often fifty to one hundred feet thick. The limestones capping these hills and divides are more or less cherty, having cavities lined with druses of quartz, locally known as mineral blossom. In many places these same limestones have their jointing and bedding planes covered with the same quartz. In one locality the writer found a bed of sandy rock completely honeycombed with their shell-like druses. The bed was at least one foot in thickness. Immediately above and below at least fifty per cent of the rock was also drusy quartz. Underneath these strata the limestone becomes almost entirely free from quartz and in general appearance is hardly to be distinguished from the St. Joseph limestones. The occurrence of cherty or drusy quartz in a limestone has hitherto been the sole means of distinguishing

between the Potosi and the St. Joseph. If the limestone was cherty it has been called Potosi; if not, St. Joseph, or Bonne Terre.









Most of the gulches cut by the streams expose the contacts between the cherty and non-cherty limestones. As the cherty limestones show well up the sides of the hills, it has been assumed that only the summits of the hills and divides were Potosi.

In the geological map of St. François County, Mo. (Bull. U. S. G. S. No. 132, "Diss. Lead Ores of S. E. Mo."), Mr. Arthur Winslow has accepted this erroneous conclusion and further states (*ibid.*, p. 17): "The rocks of this formation [Potosi] are found principally west and north of the area here treated of [St. François Co.] and they occur within it only over the hills. The upper limits of the formation are, therefore, not reached, and it is probable that no sharp line of separation between it and the underlying St. Joseph limestone exists."

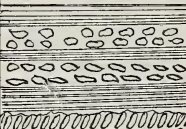
The writer discovered a positive break between the two series in the bed of Flat river about one mile up the river from Elvins, just a little above where the M. R. and B. T. R. R. bridges the stream. Here the river has washed bare a heavy bed of limestone conglomerate. The appearance of the conglomerate is very striking, being composed of flat, rounded, disks of limestone lying edgewise, as is shown in the accompanying geological column. The conglomerate here appears to be about ten feet in thickness and below the layer of disk-like pebbles, five to six inches thick, it is massive.

In the railroad cut above the river exposure, the conglomerate is seen to be overlaid with soft clay slates from a few inches to several feet in thickness. From this up to the chertless Potosi, there is a succession of clay slates interstratified with thin beds of conglomerate. Judging by drill holes and by natural sections, the thickness of the conglomerate series is not less than fifty feet and probably in places it is one hundred and fifty to two hundred feet thick. The conglomerate is not a mere local occurrence. From its outcrop in Flat river the writer traced it continuously for one mile towards the Central Lead Co.'s office; and in isolated exposures for another mile to near the Theodora shaft of the same company. Southeast, it was found on the face of a bluff about two miles from Farmington, about four miles air line from the original outcrop. To the west, near Irondale, a distance of about eight miles, drill cores showed it to be present at a depth of two hundred and sixty-two feet.

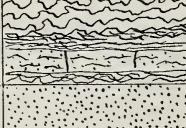
The pebbles of the conglomerate, as far as seen, are all magnesian limestone. The interstitial paste or cement is with-

Middle or Upper Cambrian.	Potosi Residuary.		100'	Residuary Potosi Clay with Drusy Quartz.
	Potosi Limestones.		350'	Cherty Limestone.
		Drusy Quartz.		
Shaly Limestone.				
Potosi Slates and Conglomerates.				100'
Cambrian.	Bonne Terre, or St. Joseph, Limestone.		6 1/2''	Dividing line. Potosi.
			300'	St. Joseph.
				Upper Lead Zone.
S. S. La Motte.		100'	Lower Lead Zone. Lingulella.	
			Sandstone. Lingulella.	
Archean				Granite and Porphyry.

Geological Column near Flat river, St. François county, Missouri.

out exception a crystalline limestone, nearly, if not quite, pure. Accompanying the conglomerate is an oolitic limestone.

Although not traced continuously, to the points noted, the conglomerate is assumed to be identical, for the following reasons: The disk-like conglomerate, the crystalline limestone paste, the oolitic limestone, and finally, the invariable occurrence of fossils, principally trilobites and brachiopods; also beds of interstratified slate.

Fossils are very scarce in rocks of both formations save as here noted: *Lingulella* and *Obolella* in or near the junction between the La Motte sandstone and the St. Joseph; in the bands of lead-bearing clay slate in the lower and upper lead-bearing zones of the St. Joseph limestone (see geological column) and in the slates of the conglomerate series; in the conglomerate paste (trilobites, brachiopods, pteropods).

The writer feels little hesitancy, therefore, in stating positively that the beds of conglomerate mark a break in geological time between the St. Joseph and Potosi limestones. There is no doubt that this division will be found to be widely extended, but at present nothing can be here offered in support outside of St. François county and the eastern edge of Iron county.

The Potosi will henceforth be recognized as including and lying above the slates and conglomerates, and will extend far down many of the streams instead of being referred to the hill tops above.

As to the age, its determination rests on fossils, and these have been submitted to Professor Beecher, who has generously consented to examine them.

ART. XXXVIII. — *Note on the Cambrian Fossils of St. Francois County, Missouri*; by C. E. BEECHER.

THE small collection of fossils submitted to the writer by F. L. Nason, for identification, is interesting, especially as it determines the geological horizon of an extensive series of limestones, sandstones, conglomerates, etc., in southeastern Missouri, the age of which has hitherto been somewhat in doubt. Also, since these strata are intimately associated with the lead-bearing rocks of this region, the identification has considerable economic value.

It is stated by Arthur Winslow, in a paper on "The Disseminated Lead Ores of Southeastern Missouri"* (p. 11), that although these rocks are placed in the Lower Silurian "The possibility still remains that there may be a faunal break which will admit of some of the lower strata being classed as Cambrian, though there is nothing in the stratigraphy to suggest it. This must, therefore, be left to the paleontologists, and owing to the dearth of fossils the problem is not an easy one for them to solve." In Volume IX of the Missouri Geological Survey (Pt. IV, p. 52, Keyes, 1895) the Fredericktown dolomite (= St. Joseph limestone) is referred to the Upper Cambrian on account of the presence of *Lingulella Lamborni* (Meek), but since this species is peculiar to the horizon, and the genus has a much wider range, this correlation is not established. A general statement is made by Keyes regarding this region (*l. c.*, p. 44) that "No strata younger than the Cambrian are believed to be represented. But few fossils have been found in the rocks of the area, so that the faunal evidence as to geological age is somewhat meager." The present collection of fossils, made by Mr. Nason, indicates that the entire series is older than the Lower Silurian (Ordovician) and that at least the upper portion probably belongs to the Upper Cambrian.

All but one species of the fossils were obtained from the lower members of the Potosi limestones, and, since this is the topmost formation of this region, its correlation is of the first importance. The fossils occur abundantly in the limestone and conglomerate beds and more sparsely in the sandstones. They consist chiefly of fragments of trilobites, with a few brachiopods and other forms. Lithologically there is a very close resemblance between these fossil-bearing beds and those of a similar horizon in the Black Hills of South Dakota. Limestones, limestone-conglomerates, and sandstones of the same appearance are found in both sections. Faunally, there

* Bulletin No. 132 of the United States Geological Survey, 1896.

is a suggestion of affinity with the Potsdam fauna of Wisconsin and Texas. A careful comparison, however, reveals that these resemblances are more general than specific and that the species seem to be distinct. Nevertheless, the facies of this fauna seems to indicate Upper Cambrian, though further studies with additional material may show it to belong to the middle member.

Owing to the small number of specimens in the present collection, the number of species is necessarily limited. It will doubtless be considerably increased by future collections. Among the trilobites the genera *Ptychoparia*, *Ptychaspis*, *Chariocephalus*, and *Crepicephalus*, are more or less clearly identifiable. A species of *Chariocephalus* closely agrees with the *C. onustus* of Whitfield.

The species of brachiopods seem to be fairly abundant, especially an orthoid shell resembling in some respects *Bilingsella*. It occurs in the shaly partings between the layers of limestone. A species of *Acrotreta* and a *Lingulella* are common both in the limestones and arenaceous beds.

Hyolithes primordialis Hall and a small species of *Platyceras* also occur in the limestones, together with segments of cystidean or crinoidal columns.

Abundant remains of a linguloid shell are found on the lower, or La Motte, sandstones constituting the basal member of the clastic rocks of the section. Making allowances for different conditions of preservation, this species may be identified with the *Lingulella Lamborni* of Meek, which occurs in some green shales of the same age in Madison County, a little further south. In the absence of other evidence, the diagnostic value of this brachiopod is very slight, and it is impossible to say whether the Bonne Terre, or St. Joseph, limestones and the La Motte sandstones represent Lower Cambrian terranes or whether they with the Potosi all belong to the Middle or Upper Cambrian.

The important point of this correlation is that, upon paleontological evidence which has hitherto been largely wanting, an extensive area and thickness of sedimentary rocks are definitely placed in the Cambrian.

Yale University Museum, New Haven, Conn., June, 1901.

ART. XXXIX.—*Discovery of Eurypterid Remains in the Cambrian of Missouri*; by C. E. BEECHER. (With Plate VII.)

THE wonderful development of merostomes in various parts of the world at about the close of the Silurian has long been recognized, and the suddenness of their appearance out of an apparently clear paleozoic sky has been a matter of considerable speculation. Almost at the same instant of time there appeared on the geologic horizon a marvelous assemblage of these ancient arthropods. A very few scattering forerunners are known from older rocks, but most of them are small and strange creatures, little resembling the characteristic *Eurypterus* and *Pterygotus* of the Upper Silurian, and in fact belonging to other orders of the Merostomata.

In North America the known genera and species of the order Eurypterida belong almost exclusively to the Waterlime group (Rondout) above the Salina beds. Dr. John M. Clarke* has recently announced the discovery, by Mr. C. J. Sarle, of a new Eurypterid fauna at the base of the Salina, which carries this peculiar biologic facies one comparatively brief stage further back. Evidences of still older forms are very meager. A single species of *Eurypterus* (*E. prominens* Hall) is referred to the Clinton beds of the Silurian with considerable doubt. The next indication of a greater antiquity of this order consists of a fragment of an abdominal segment and a single jointed limb, from the Utica slate of New York, described by C. D. Walcott† as *Echinognathus Clevelandi*.

It is therefore of considerable interest and importance that a new and much older horizon for the Eurypterida can now be chronicled.

Mr. Arthur Thacher, President of the Central Lead Company of Missouri, formerly a professor in Washington University, found a nearly entire specimen of a new Eurypterid in the Potosi limestone of St. Francois county, and through his generosity and the kindly interest of Mr. Frank L. Nason, the specimen was transmitted to the Yale University Museum. Owing to the supposed scarcity of fossils in the Potosi and St. Joseph terranes of Missouri, their correlation was long a matter of uncertainty, until Mr. Nason described certain horizons bearing an abundant and characteristic Cambrian fauna.

* Notes on Paleozoic Crustaceans. N. Y. State Museum, Report of the State Paleontologist for 1900. 1901.

† Description of a New Genus of the Order Eurypterida from the Utica Slate. This Journal (3), vol. xxiii, 1882.

The specimen here described at once suggests the familiar and well-known genus *Eurypterus*, and only when its characters are studied in connection with its geological occurrence is it apparent that its differences are of sufficient importance to warrant its generic separation. The specimen represents nearly the entire dorsal test of the animal and consists of the cephalothorax with the abdominal segments, including the telson spine.

The cephalothorax is comparatively shorter and wider than in *Eurypterus*, the eyes are further forward, nearer together, and more oblique, and besides the telson but eleven abdominal somites can be determined on the dorsal side, instead of twelve as in *Eurypterus*. These differences are considered as indicative of a new genus and it is proposed to recognize this type under the name *Strabops* nov. gen., with *Strabops Thacheri* n. sp., as the type species. The generic name is in allusion to the inward turning or squinting of the eyes (*στραβός* squinting, and *ὄψις* face).

Doubtless many generic differences will appear when the appendages of this type are obtained. The differences in the characters available for comparison are quite as great as between *Eurypterus* and *Dolichopterus*, *Stylonurus*, *Anthraconetes*, or *Eusarcus*. This taken with the fact that practically all the Cambrian genera, especially the more highly organized types, became extinct long before the Upper Silurian, lends support to the conclusion that *Strabops* is generically distinct from any hitherto known form.

STRABOPS THACHERI gen. et sp. nov. (Plate VII.)

Body broadly ovate in general outline exclusive of the telson, slightly convex in the specimen, though probably quite arched both transversely and longitudinally in life, as indicated by the outline of the separate segments.

Cephalothorax short and broad, length less than one-half the width, anterior and lateral margins regularly rounded, posterior margin gently curved in the middle and turning obliquely forward toward the genal extremities, which are obtusely angular.

Eyes medium sized, ovate, narrow ends pointing obliquely inward, situated in the middle of the anterior half of the cephalothorax, distant about the length of one eye, connected anteriorly by a distinct arched line or fold. The eye tubercles are mostly exfoliated, and their convexity and surface cannot be determined. *Ocelli* indicated by two spots midway between the eyes.

Abdomen. The dorsal side shows eleven segments exclusive of the telson. The axis in the specimen is slightly convex

and slopes off into the nearly flat pleural region without any line of demarkation. The greatest width is across the third segment. The extremities of the segments are rounded anteriorly and on the sides, and terminate behind as a simple angulation. The first six segments are quite uniform in length, while the three following are somewhat shorter, and the last two are a little longer.

Telson a broad flat spine, obtusely elevated along the middle.

Surface smooth, with an indication of a row of minute crenulations or scale-like markings near the posterior edge of each segment.

Dimensions. Greatest length of specimen 110^{mm}, length exclusive of telson 82^{mm}; greatest width, allowing for compression on left side, 60^{mm}; length of cephalothorax 20^{mm}, width 49^{mm}; greatest width of telson 17^{mm}.

Formation and locality. From the lower members of the Potosi limestone, Flat river, St. François county, Missouri.

The only known genus of merostomes besides *Strabops* occurring in the Cambrian is *Aglaspis* Hall, represented by two species (*A. Barrandi* and *A. Eatoni* Whitf.). But since *Aglaspis* belongs to the order Synxiphosura, it leaves *Strabops* as the present sole representative of the Eurypterida.*

* Although *Aglaspis* was compared with *Limulus* by Professor Hall, and its affinities were distinctly stated as with the Merostomata, yet most subsequent writers have overlooked its true relationships and have included it in their lists of trilobite genera. The family named Aglaspidae was first employed in 1877 by S. A. Miller in "The American Palæozoic Fossils," p. 208, and the restoration of the family to the Merostomata was first made by the writer in a paper entitled "Outline of a Natural Classification of the Trilobites" (this Journal (4), vol. iii, p. 182, 1897).

EXPLANATION OF PLATE VII.

Strabops Thacheri Beecher.—Dorsal side of type specimen $\times 3/2$. Potosi limestone (Cambrian), St. François county, Missouri. Original in Yale University Museum.

Yale University Museum,
New Haven, Conn., June, 1901.



STRABOPS THACHERI Beecher.

ART. XL. — *The Determination of Persulphates*; by
CHARLES A. PETERS and SETH E. MOODY.

[Contributions from the Kent Chemical Laboratory of Yale University—CIII.]

IN a recent article by Namias, of which, however, only the abstract is at our disposal,* it is proposed to substitute for the method of reducing the persulphate by a ferrous salt and estimating the excess of the latter—a method which the author characterizes as inaccurate—the treatment of the persulphate by potassium iodide for a period of ten or twelve hours, and titration by thiosulphate of the iodine set free; and Grützner† has recently stated that a solution of arsenious oxide is well suited for the determination of the oxidizing power of persulphates, the reaction being hastened by heat and the presence of alkaline hydroxide. A test of the processes of Namias and Grützner led us to consider also the method of LeBlanc and Eckardt,‡ as well as the previously proposed method of Mondolfo,§ in order that the indications of all these methods might be brought into comparison.

LeBlanc and Eckardt|| state and bring experimental results to show that when a mixture containing a persulphate, a sufficient excess of ferrous salt, and sulphuric acid, is heated at 60°–80°, or allowed to stand ten or twelve hours, the persulphate is reduced, and the amount of ferrous salt oxidized is the measure of the amount of persulphate originally present in solution. This is the method to which Namias takes exception. Marshall¶ is authority for the statement that persulphates liberate iodine from potassium iodide, and that the action is hastened by heat and affected little by the addition of dilute sulphuric acid. Upon this reaction Mondolfo** has based a method for the estimation of persulphates, which consists in heating a mixture containing the persulphate and potassium iodide in a stoppered bottle for ten minutes at 60°–80°, and titrating by thiosulphate the iodine set free. The process which Namias†† proposes for the estimation of persulphates—without knowledge of Mondolfo's method—differs from the iodometric method of Mondolfo in the point that the interaction between the iodine and the persulphate is carried out at the ordinary atmospheric temperature and prolonged ten or twelve hours, when the estimation is made by thiosulphate of the iodine set free in the action.

* Chem. Centralblatt, 1900, ii, p. 806.

† Zeit. f. Electrochemie, 5, 355–7.

‡ Loc. cit.

** Loc. cit.

† Ibid., 1900, i, p. 835.

§ Chem. Zeitung, 23, p. 699.

¶ Jour. Chem. Soc., 59, 771.

†† Loc. cit.

Method of LeBlanc and Eckardt.

The reagents used in our experiments were a solution of ammonium persulphate, 10 grm. of the salt to the liter; an acidified solution of ammonio-ferrous sulphate, 20 grm. to the liter; an approximately tenth-normal solution of potassium permanganate; and sulphuric acid of half strength. The standard of the potassium permanganate solution was determined by comparison with a solution of arsenious oxide.* The effect upon the reaction of variations in time, temperature, and amount of ferrous salt were tried, and the results given in Table I.

TABLE I.
Volume of liquid 100^{cm}³.

Ammonium persulphate, 10 grm. to liter. ^{cm} ³.	(NH ₄) ₂ Fe(SO ₄) ₂ ·6H ₂ O solution 20 grm. to liter. ^{cm} ³.	KMnO ₄ app. N/10, to oxidize the excess of ferrous salt. ^{cm} ³.	Treatment.	(NH ₄) ₂ S ₂ O ₈ calculated from ferrous salt oxidized. grm.
A				
Heated 10 min.				
12·5	25	2·11	60°–80°	0·1216
12·5	25	2·18	“	0·1209
12·5	25	2·11	“	0·1216
12·5	25	2·11	“	0·1216
12·5	50	15·00	“	0·1218
25·0	50	4·21	“	0·2426
B				
Stood 11 hours.				
12·5	26	1·89	21°–25°	0·1214
12·5	26	1·80	“	0·1224
12·5	40	8·75	“	0·1221
12·5	40	8·75	“	0·1221
C				
Carbon dioxide above the liquid.				
Stood 11 hours.				
12·5	40	8·75	21°–25°	0·1221
12·5	40	8·78	“	0·1218

In section A are given the results of experiments obtained by heating the mixture of persulphate, ammonio-ferrous sulphate, sulphuric acid, and water, on the steam bath for ten minutes, at a temperature of 60°–80°. In section B are recorded the results of experiments in which the same mixture was allowed to stand 11 hours at the ordinary room tempera-

* Gooch and Peters, this Journal, viii, 125.

ture. In the experiments recorded in section C, the air above the liquid was replaced by carbon dioxide. It is seen that the results of the experiments given in the three sections of the table agree quite closely with one another, and the average of these experiments gives a value to the persulphate solution of 0.1217 grm. of the salt in 12.5 cm³.

Experiments were made in blank to discover the amount of ferrous salt oxidized in 11 hours by other agencies than the persulphate. The amount of oxidation in that time, however, was too small to be detected, but, when the solution was allowed to stand 36 hours a slight oxidation was noticed, which if calculated as persulphate, would be equivalent to 0.0006 grm. The correction for 11 hours standing, upon this basis, therefore, would be 0.0002 grm., which is obviously so small that it may be disregarded. This absence of any significant oxidation of the ferrous salt was undoubtedly due to the fact that the solution of ammonio-ferrous sulphate had been standing some time before standardizing and was devoid of any active oxygen.

Method of Grützner.

In testing the value of the persulphate solution according to the method of Grützner,* the mixture containing the persulphate, standard arsenite solution, and sodium hydroxide was raised to the boiling point, cooled, faintly acidified with sulphuric acid, then made alkaline with potassium bicarbonate, and after adding a large excess of the last, the arsenite remaining unoxidized was titrated by iodine. Experiments made in blank, that is experiments in which the mixture of arsenite and alkaline hydroxide was raised to the boiling point, cooled, made acid with sulphuric acid, then alkaline with potassium bicarbonate, and titrated with iodine, showed a deficiency of arsenious acid as compared with the experiments, similarly conducted, in which the mixture was not subjected to heat. The effects of various specimens of sodium and potassium hydroxide were tested in the process—sodium and potassium hydroxide made by the alcohol process, potassium hydroxide by the barium hydroxide process, sodium hydroxide especially prepared from sodium carbonate and calcium hydroxide—as well as a specimen of potassium carbonate. In the case of all but the potassium carbonate, more or less oxidation was observed, sometimes trifling, sometimes considerable. The same specimens of potassium and sodium hydroxides and potassium carbonate were tested in the absence of the arsenite solution, by dissolving them in water, heating the solution to the boiling point, cooling, adding sulphuric acid in faint excess and

* Loc. cit.

then potassium bicarbonate, and titrating with iodine to a color without starch. In all cases, save that of the potassium carbonate, the color of the first drop of iodine solution added was destroyed, and from 0.06–0.19^{cm³} were necessary to bring the permanent iodine color. The results of these experiments are given in Table II.

TABLE II.
Arsenic solution No. 1.

Arsenite solution taken. cm ³ .	NaOH present. gm.	KOH present. gm.	K ₂ CO ₃ present. gm.	Iodine solution required to bring color. cm ³ .	Remarks.
25	--	--	--	25.40	
25	2	--	--	25.36	} NaOH by CaO ₂ H ₂ , average of 4 experiments.
25	--	6	--	25.29	
25	--	5	--	25.07	KOH by BaO ₂ H ₂ .

Arsenic solution No. 2.

25	--	--	--	25.54	
25	--	6	--	25.42	KOH by alcohol.
25	--	6	--	25.30	KOH by BaO ₂ H ₂ .
25	--	--	6	25.56	
--	4	--	--	0.12	NaOH by CaO ₂ H ₂ .
--	6	--	--	0.06	NaOH by alcohol.
--	--	6	--	0.06	KOH by alcohol.
--	--	6	--	0.19	KOH by BaO ₂ H ₂ .
--	--	2	--	0.07	KOH by BaO ₂ H ₂ .
--	--	--	6	0.02	

Potassium carbonate proves to be inefficient as a substitute for an alkaline hydroxide, but by using definite amounts of the hydroxide, and introducing a correction for the oxidation determined by the blank tests, the real oxidizing effect of the persulphate upon the arsenite may be deduced. Table III contains the values found by Grützner's process thus corrected, as well as uncorrected results.

TABLE III.

Ammonium persulphate solution taken. cm ³ .	Arsenite solution. cm ³ .	NaOH by CaO ₂ H ₂ . gm.	Calculated from Iodine actually used. gm.	(NH ₄) ₂ S ₂ O ₈ corrected for oxidation in blank. gm.
12.5	25	2	0.1223	0.1218
12.5	25	2	0.1223	0.1218
12.5	25	2	0.1225	0.1220
12.5	25	2	0.1229	0.1220

The average of the corrected figures gives a value to 12.5 cm³ of the persulphate solution of 0.1219 gm. of the salt.

Method of Mondolfo.

In certain experiments conducted as described by Mondolfo* a mixture, 25 cm³ in volume, containing 12.5 cm³ of the persulphate solution, 1.0 gm. of potassium iodide, was heated in a stoppered bottle 10 minutes on the steam bath, and after cooling, the liberated iodine was titrated by thiosulphate. The readings were made without starch, which, however, was added afterwards to verify the observation. In other experiments, similarly conducted, the volume of the liquid containing the persulphate and the potassium iodide was increased to 100 cm³ and the mixture heated 10 minutes on the steam bath, the temperature being 60°–80°. The repeated return of the iodine color when the volume of the liquid was 100 cm³ showed plainly that only a partial reduction of the persulphate had taken place.

When, however, the mixture at a volume of 100 cm³ was heated on the steam bath for 30 minutes, the results agreed with those obtained by the treatment at a volume of 25 cm³. The results of these two sets of experiments are given in sections A and B of Table IV. After the iodine in the experiments which are recorded in section A of Table IV had been titrated by thiosulphate, sulphuric acid was added to the mixture and a blue color appeared immediately, showing, even in these experiments conducted at a volume of 25 cm³, that the reduction of the persulphate had been incomplete. This fact suggested a study of the effect of the presence of sulphuric acid on the process conducted otherwise as described by Mondolfo. Accordingly experiments were made similar to those already described excepting that a small amount of sulphuric acid was present. The results of these experiments are given in section C of Table IV.

In a blank test made with 1 cm³ of sulphuric acid present, a small amount of iodine was liberated; and when, in a similar experiment the air over the liquid was replaced by carbon dioxide the amount of iodine liberated was less. The results of these experiments in blank are given in section D of Table IV. It is seen from the results of experiments given in sections A and B of the Table that the method as described by Mondolfo gives constant results provided the volume is small and the heating prolonged. The instantaneous appearance of the iodine color upon acidifying with sulphuric acid showed, however, that a very small amount of the persulphate had escaped reduction. Still, the presence of sulphuric acid in the

* Loc. cit.

TABLE IV.

Ammonium persulphate solution. cm ³ .	KI. gm.	H ₂ SO ₄ 1:1. cm ³ .	Volume. cm ³ .	Time of heating. minutes.	Na ₂ S ₂ O ₃ required. app N/10. cm ³ .	(NH ₄) ₂ S ₂ O ₈ calculated from sodium found. gm.
A						
12.5	1.0	----	25	10	10.65	0.1200
12.5	1.0	----	25	10	10.74	0.1210
12.5	1.0	----	25	30	10.73	0.1209
B						
{ 12.5	1.0	----	100	10	9.89*	0.1124 }
{ 12.5	1.0	----	100	10	8.99*	0.1013 }
12.5	1.0	----	100	30	10.70	0.1206
12.5	1.0	----	100	30	10.72	0.1208
12.5	1.0	----	100	30	10.72	0.1208
C						
12.5	1.0	0.05	25	30	10.78	0.1214
12.5	1.0	0.05	100	30	10.81	0.1218
12.5	1.0	1.0	100	30	10.81	0.1218
12.5	1.0	1.0	100	30	10.84	0.1221
D						
----	1.0	----	100	30	0.00	0.0000
----	1.0	1.0	100	30	0.07	0.0008
----	1.0	1.0	100	30	0.10	0.0011
----	1.0	1.0	100	30	0.03†	0.0003

process is hardly to be recommended, because of the sensitiveness of the hydriodic acid set free to the oxygen of the air and the oxygen dissolved in the water. The value of 12.5^{cm³} of the persulphate solution obtained by the method of Mondolfo, found by averaging the results of experiments in sections A and B (omitting the first two experiments under section B) is 0.1207 gm., while that found by averaging the results of experiments in section C and deducting the correction given in the experiments under section D is 0.1208 gm.

Method of Namias.

In the process for the estimation of persulphates carried out as described by Namias,† a mixture containing 12.5^{cm³} of the persulphate solution, 1.0 gm. of potassium iodide, and water sufficient in some experiments to make a volume of 25^{cm³}, and in other experiments 100^{cm³}, was allowed to stand 11 hours in a stoppered bottle and the iodine set free was titrated by thio-sulphate. After the titration by thiosulphate the mixture was allowed to stand still longer, and 16 hours later the blue starch iodide color which had developed in the experiments with the

* Color returned.

† Air over liquid replaced by carbon dioxide.

‡ Loc. cit.

volume of 100^{cm}³ was destroyed by thiosulphate. No more color appeared on standing. The results of these experiments are given in section A of Table V. In section B of Table V are recorded experiments in which the mixtures were allowed to

TABLE V.

Ammonium persulphate solution. cm ³ .	KI. gm.	Volume of liquid. cm ³ .	Time of standing. hrs.	Atmosphere above liquid.	(NH ₄) ₂ S ₂ O ₈ calculated from iodine found 11 hours standing. gm.	After standing the number of hours indicated in the fourth column. gm.
A						
12.5	1.0	25	26	air	0.1203	0.1203
12.5	1.0	25	26	air	0.1196	0.1196
12.5	1.0	100	26	air	0.1191	0.1207
12.5	1.0	100	26	air	0.1190	0.1209
B						
{ 12.5	1.0	25	20	air	----	0.1211
{ 12.5	1.0	25	24	air	----	0.1213
{ 12.5	1.0	100	20	air	----	0.1211
{ 12.5	1.0	100	24	air	----	0.1211
{ ----	1.0	100	24	CO ₂	----	0.0000
{ 12.5	1.0	25	20	CO ₂	----	0.1216
{ 12.5	1.0	25	25	CO ₂	----	0.1214
{ 12.5	1.0	100	20	CO ₂	----	0.1212
{ 12.5	1.0	100	24	CO ₂	----	0.1217
C						
					H ₂ SO ₄ 1:1 cm ³ .	
{ 12.5	1.0	25	25	air	1.0	0.1248
{ 12.5	1.0	100	24	air	1.0	0.1220
{ 12.5	1.0	100	24	air	1.0	0.1226
{ 12.5	1.0	25	17	CO ₂	0.05	0.1217
{ 12.5	1.0	25	24	CO ₂	0.05	0.1212
{ 12.5	1.0	25	17	CO ₂	1.0	0.1222
{ 12.5	1.0	25	23	CO ₂	1.0	0.1223
{ 12.5	1.0	100	17	CO ₂	0.05	0.1214
{ 12.5	1.0	100	24	CO ₂	0.05	0.1214
{ 12.5	1.0	100	17	CO ₂	1.0	0.1214
{ 12.5	1.0	100	24	CO ₂	1.0	0.1219
{ 12.5	1.0	100	23	CO ₂	1.0	0.1220
{ ----	1.0	25	20	air	1.0	0.0014
{ ----	1.0	100	20	air	1.0	0.0006
{ ----	1.0	25	24	CO ₂	1.0	0.0011
{ ----	1.0	100	24	CO ₂	1.0	0.0003

stand 20–25 hours, the air about the liquid in some experiments being replaced by carbon dioxide. Though carbon dioxide shows no tendency to liberate iodine in the blank test, the persulphate appears to liberate in its presence a little more iodine than in its absence. This experience naturally suggests an effect of acidity. The effect of the presence of sulphuric acid in the process otherwise conducted as described by Namias was therefore tried, the air over the liquid being replaced by carbon dioxide. The results of these experiments are recorded in section C of Table V.

It is seen from the experiments conducted as described by Namias that the reduction of the persulphates in the time stated by Namias, 10–12 hours, is plainly incomplete unless the volume of the liquid is small. If the experiments are conducted at the greater dilution the time of standing must be increased in order that subsequent standing may not result in the return of color. In the presence of sulphuric acid more iodine is liberated than in its absence, and the amount is greater when the air above the liquid is not replaced by carbon dioxide, and when the volume is small. The amounts of iodine liberated under similar conditions in blank experiments prove to be appreciable and naturally greater when the atmosphere above the liquid is air. When these amounts, averaging the equivalent of 0.0007 gram. of the persulphate when the atmosphere is carbon dioxide, and about 0.0010 gram when the atmosphere is air, are deducted from the actual indication, the figures agree well with those found for the same amount when sulphuric acid is not present. Plainly, the addition of the acid adds nothing to the regularity and value of the process. The value of 12.5 cm³ of the persulphate solution obtained by the method of Namias is 0.1208 gram.

Arseniate—Iodide Method.

The estimation of chlorates is accomplished according to Gooch and Smith* by allowing a mixture containing the chlorate, a definite amount of standard potassium iodide solution, an arseniate, 20^{cm} of 1:1 sulphuric acid, to boil from a volume of about 100^{cm}³ to 35^{cm}³; the difference between the amount of iodine required to oxidize the arsenious acid produced and the amount of iodine in the potassium iodide originally present being the measure of the chlorate taken. It is interesting to note that persulphates can be estimated in a similar manner. Mixtures containing 12.5^{cm}³ of the persulphate solution, 0.5 gram. of potassium iodide, 2.3 gram. of hydrogen

* This Journal xlii, 220.

potassium arseniate, and 20^{cm}³ of 1:1 sulphuric acid, and water enough to make the total volume about 100^{cm}³, were boiled in a trapped Erlenmeyer beaker until the volume decreased to 35^{cm}³, and the arsenite present after the solution was made alkaline with potassium bicarbonate was estimated with iodine. The results of these experiments are given in Table VII.

TABLE VII.

Ammonium persulphate solution. cm ³ .	KI present. grm.	Iodine required for oxidation of arsenite. grm.	Iodine liberated by persulphate. grm.	(NH ₄) ₂ S ₂ O ₈ equivalent to iodine liberated. grm.
12.5	0.1875	0.0514	0.1361	0.1225
12.5	0.1875	0.0522	0.1352	0.1217
12.5	0.1875	0.0514	0.1361	0.1225
12.5	0.1875	0.0516	0.1359	0.1222

These results agree closely with one another and in the average, 0.1222 grm., accord well with the results of the process of Grützner and of LeBlanc and Eckhardt.

To compare the values obtained for the persulphate solution the averages of the results obtained by the different methods, together with the average of all the experiments, are given in Table VI.

TABLE VI.

Process.	Number of experiments.	Average of results. grm.
Mondolfo	6	0.1207
Namias	8	0.1208
LeBlanc and Eckhardt	12	0.1217
Grützner (corrected)	4	0.1219
Arseniate-iodide method	4	0.1222
Average of whole		0.1213

The results obtained by the process of Mondolfo and the process of Namias, both of which involve the liberation of iodine from potassium iodide and the titration of that iodine by thiosulphate, are practically identical and lower than the results obtained by the other three methods. The results obtained by the process of LeBlanc and Eckardt in which the persulphate is reduced by a ferrous salt, by the process of Grützner in which an arsenite solution is the reducing agent, and the arseniate iodide method in which the persulphate is determined by the difference between the amount of iodine in

an iodide added and the amount necessary to oxidize the arsenite remaining after boiling the solution, are all in quite close agreement and are all higher than those obtained by the processes of Namias or Mondolfo.

It is readily seen that the results of the experiments obtained by the process of LeBlanc and Eckardt are nearer the average of the results of all the methods than those of Namias or the similar process of Mondolfo, and this fact would show that the statements of Namias regarding the inaccuracy of the method of estimating persulphates by the reduction with a ferrous salt is without foundation.

The process of LeBlanc and Eckardt is simple, rapid and convenient. The method of Grützner is advantageous in that the ordinary arsenite solution is the standard for the process, but requires the application of a correction. The method of Mondolfo is simple and fairly rapid, but tends to give low results. The method of Namias is slow because the experiments must stand 10 to 12 hours, and the results of these experiments, like those obtained by the method of Mondolfo, are lower than the results obtained by the other methods. The arseniate-iodide method introduced as a control, is accurate but less simple than the other methods.

We wish to thank Professor F. A. Gooch for help given during the progress of this investigation.

ART. XLI. — *Studies of Eocene Mammalia in the Marsh Collection, Peabody Museum; by J. L. WORTMAN.*

[Continued from p. 296.]

The Vertebrae.—With the exception of the right half of the atlas, and perhaps more than half of the caudals, the vertebral column is present in its entirety; it is preserved, moreover, very nearly in its natural position, with the vertebrae interlocked in such a manner that there can be no doubt whatever of the presacral formula.

The atlas bears a very strong resemblance to that of the felines. The transverse process is proportionally less extended and does not project so far behind the facets for the axis; it is emarginate behind, considerably thickened, and pierced by the canal for the vertebral artery much as in the cats. The anterior margin of the process displays a deep notch, in which the artery winds forward in its course to the *sinus atlantis*. This latter has much the same relative size, position, and relation as in the felines. The cup-shaped articular facets for the condyles are large and roomy, the tubercle for the transverse ligament prominent, and the superior arch is of good breadth.

As Scott has remarked of *Mesonyx*, the axis exhibits some peculiarities, the most conspicuous of which is the very large backwardly projecting spine. The odontoid is rather long and conical, the atlantal facets are large and slightly convex, the body is strongly keeled, and the transverse process long and tapering. The spine rises high above the body; it projects comparatively little forward, reaching only opposite to the root of the odontoid, but posteriorly it is produced into a long tapering process, which overhangs nearly the entire third cervical. The remaining cervicals, like the atlas and axis, are proportionally stout and heavy, evidently in relation with the large size of the head. Their neural spines increase rapidly in height, that of the last almost equaling in length that of the first dorsal. The bodies of all the anterior cervicals have strong inferior keels which bifurcate posteriorly and terminate in two long protuberances. The plan of arrangement of the transverse processes is similar to that of the Carnassidents. The costal processes or inferior lamellæ are small in the anterior vertebrae, but increase rapidly in size to the seventh. The *vertebra prominens* has a simple transverse process, which is not perforated by the vertebrarterial canal.

The dorso-lumbar formula is 19, as in the Marsupials, whereas it is very generally 20 among the Carnassidents. There is reason to believe that all the Creodonts had the marsupial

rather than the carnassident formula.* The dorsals are twelve in number, and of these the neural spine of the first is broad, flat, and greatly elongated; it is the longest of the series, those of the succeeding vertebræ gradually decreasing in height to the eleventh or anticlinal vertebra. The spines have a very backward slope up to this point, where they change abruptly to a forward direction. This, as far as I am aware, is the point at which the anticlinal occurs in most of the Carnassidents. On the eighth dorsal, metapophyses make their appearance and increase in size posteriorly, but there are apparently no representatives of the anapophyses developed.

The lumbar are seven in number; they have short, broad, neural spines and heavy, keeled centra, increasing in size from before backward to the antepenultimate, which is the largest. The transverse processes are long and thin, with a forward and downward direction. The zygapophyses are powerful and, as Cope has observed, are closely interlocking. The articulation is effected by means of the half-cylindrical postzygapophyses fitting into half-cylindrical prezygapophyses. They differ materially from those of some other Creodonts, notably *Patriofelis*, in which they are sigmoid in cross-section.

The sacrum is somewhat damaged, but enough remains to show that the auricular process was large and rugose, that the spines were of moderate size, and that there were very probably three vertebræ entering into its composition. It is relatively very narrow. The caudals are much weathered and many are missing. The proximal ones are short and proportionally but little larger than those of the dog. Those from a more posterior position are long and slender, but not much more so than those of many of the modern Carnassidents. There is no means of judging of the length of the tail, but in comparison with such a type as *Patriofelis*, the tail was reduced and slender. This supposition comports well with the highly-developed cursorial habits of these forms.

Ribs and Sternum.—There are twelve pairs of ribs, and for a member of the Carnivora, the anterior ones are remarkably broad and flat; they are, indeed, much more like those of an Ungulate than a Carnivore. The first is short and stout. The third is the broadest, those posterior to it becoming gradually narrower to the eighth, which is slender and subround in transverse section. All the ribs have a well-developed tuberculum and capitulum, with the exception of the last three, in which the tuberculum is absent. As compared with that of the dog, the capacity of the thoracic cavity was apparently considerably smaller. Some four or five of the sternibræ, figure 45, are

* An exception to this must be made in the case of *Oxyæna lupina*, in which the formula is the same as in the Carnassidentia. It is probably likewise true that its successor *Patriofelis* had the same formula.

preserved with the skeleton, but not being in place, it is not absolutely certain just how they should be arranged. They are so strikingly different from the narrow elongate sternals of any of the modern Carnivora, that, were they found separately, one would scarcely suspect that they belonged to an animal of this order. On comparison with the corresponding bones of the Marsupials, however, especially those of an opossum, figure 46, they are seen to bear a very decided resemblance,—so marked, in fact, that I have no hesitancy in arranging them after this species. The presternal piece is missing as well as

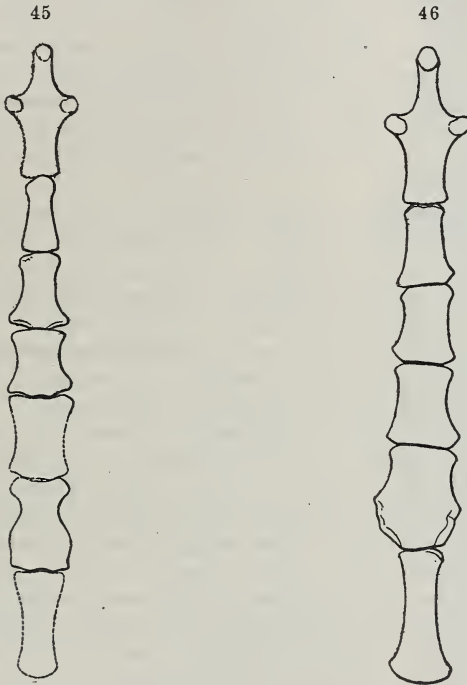

FIGURE 45.—Ventral view of the sternum of *Dromocyon vorax* Marsh; one-fourth natural size. (Type.)

FIGURE 46.—Ventral view of the sternum of an opossum, *Didelphys virginiana*; natural size.

the xiphisternum, but apparently all the mesosternal segments are represented. The anterior one of these is long and narrow, but the succeeding ones widen rapidly and become characteristically broad and flat. There is evidence of five of these pieces, the last being the widest, as in the opossum. This latter segment has a thickened ventral keel which is confined to the posterior end; its truncated extremity furnishes a thickened

base for articulation with the xiphisternum. This decided marsupial aspect of the sternum adds but another character to the already full list of osteological features in which the two groups resemble each other.

Fore Limb.—The scapula bears a general resemblance to that of the felines. A prominent spine divides the external surface into two subsequent fossæ, and terminates proximally in a rather short blunt acromion. The metacromion is not a distinct process, as in the cats, but consists of a more or less distinct lamina overhanging the glenoid border. The neck of the bone is relatively longer than that of either the dog or the cat. The glenoid cavity is oval and rather shallow, and the coracoid is small. The coracoid border is much curved and is interrupted by a very wide supercapular notch. The glenoid border is straight and much thicker than the coracoid border. The area for the origin of the *teres major* is very distinct, being separated by a well-defined ridge from the main part of the posterior fossa.

Lying immediately beneath the glenoid cavity, imbedded in the matrix, was found a small splint-like bone, which without doubt represents the clavicle; it apparently has an articular surface at one end, probably for contact with the acromion. The bone is broken so as not to display its full length, but, judging from its size, it is hardly probable that it reached the manubrium. It appears to resemble the clavicle of the *Dasyure* more than that of any of the living Carnivores.

The humeri are both considerably crushed in the proximal half of their extent, and, on this account, do not display the characters of this region very distinctly. The head is very convex from before backward and somewhat pointed behind. The greater tuberosity is prominent and extends above the level of the head; the postero-external border is drawn out into a broad laminate process, which reaches well backward. The lesser tuberosity is prominent, and there is a broad shallow bicapital groove. The character of the deltoid crest is much obscured on account of the crushing, but it appears to be considerably reduced from the more primitive *Creodont* condition. The distal end resembles that of the dog more closely than that of any other living mammal; it is much compressed from side to side—more so than in the dog,—the external condyle is little protuberant, and the supinator ridge is much reduced. The internal condyle projects behind and slightly below the edge of the trochlea, and is separated from it inferiorly by a deep notch. The anconeal and anticubital fossæ are very deep, and are placed in communication with each other by means of a large supertrochlear foramen. There is no entepicondylar foramen. The distal articular surface is divided by a very distinct rounded ridge into capitular and trochlear portions, both of

which are very concave from side to side, and convex from before backward. In its transverse concavity, the capitulum differs from that of the dog, in which it is nearly flat. The humerus and scapula are of nearly equal length.

The ulna, figure 47, differs from that of the dog in being shorter, heavier, and stouter in every way. The olecranon is of great proportional length, and in this respect, like so many other Creodonts, betrays its marsupial relationship. The proximal end is traversed by a vertical groove, the inner or radial lip of which is unusually prominent. The sigmoid cavity is deep; its posterior wall is hook-shaped, and considerably overhangs the articular surface. The shaft is somewhat flattened from side to side and is traversed by a deep longitudinal groove. The styloid process is rather short and obtuse.

The radius, figure 47, is about equal to that of the dog in size, although somewhat shorter; it is not quite as long as the humerus, and is a little longer than the fore foot. The proximal articular surface is flattened from before backward, and the proximal extremity articulates with the entire distal end of the humerus. This surface may be described as having a central concavity, with a rounded sloping edge internally, and an anteriorly beveled articular face, occupying the antero-external angle. The articular surface for the ulna is much flattened as in the dog, and is confined entirely to the under side, so that the power of pronation and supination was not greater than in the living Canidæ. The tubercle for the insertion of the biceps is placed upon the outside, just below the proximal extremity, as in the dog, and is small. The shaft is oval in transverse section, slightly curved, and has a well-marked ridge upon its



FIGURE 47.—Right ulna and radius of *Dromocyon vorax* Marsh; front view; one-half natural size. (Type.)

The radius is represented as slipped down below its natural position.

inner border. The distal extremity is enlarged, rugose, flattened from before backwards, and presents many sulci for the passage of tendons. The articular surface is concave in both

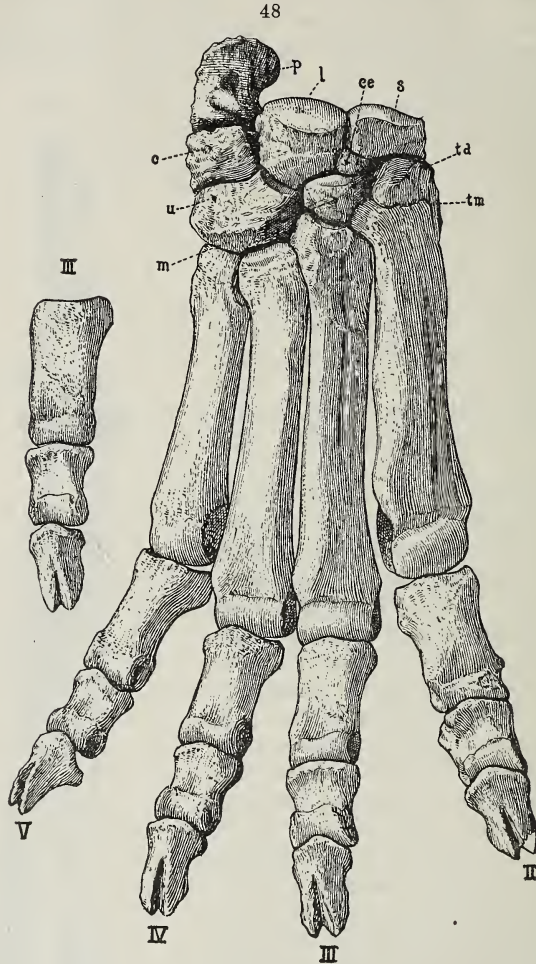

FIGURE 48.—Right manus of *Dromocyon vorax* Marsh; front view; three-fourths natural size. (Type.)

c, cuneiform; *u*, unciform; *m*, magnum; *tm*, trapezium; *td*, trapezoid; *s*, scaphoid; *ce*, centrale; *l*, lunar; *p*, pisiform; III, phalanges of third digit.

directions, and is divided by a distinct fore and aft ridge into an outer and an inner facet for contact with the scaphoid and lunar, respectively.

[To be continued.]

ART. XLII.—*The Carboniferous and Permian Age of the Red Beds of Eastern Oklahoma from Stratigraphic Evidence*; by GEORGE I. ADAMS.

[Published by permission of the Director of the U. S. Geological Survey.]

VARIOUS opinions have been expressed from time to time concerning the age of the Red Beds of Oklahoma. By some they have been called Triassic and by others Permian, but because of the general absence of fossils and the lack of stratigraphic work they have remained an uncertain group. Collections of fossils made by C. N. Gould at White Horse Springs, sixteen miles west of Alva, from the Red Bluff formation of Cragin, situated one hundred feet or more above the gypsum ledges, have been determined by Schuchert and Beede as Upper Permian forms.* Vertebrate remains from Orlando in Logan County and from Hardin in Kay County, although not fully studied, are considered by S. W. Williston as equivalent to Cope's Lower Permian fauna from the Wichita beds of Cummins in northern Texas.† The writer has recently done some stratigraphic work which has a direct bearing on the problem of the Red Beds, and it is believed that it supplies a correct interpretation of the beds and furnishes a basis for future detailed study of them.

In tracing the outcrops of the limestone formations of the Carboniferous of Kansas, the writer observed that in going southward there is a gradual transition in the character of the sediments to those which are more arenaceous, and that there is a thickening of the shales and sandstones and a thinning and final disappearance of some of the limestones. Moreover, in describing the shales of the higher portion of the Carboniferous and the lower portion of the Permian, the occurrence of purplish and maroon-colored shales was noted. The significance of these observations was not fully known, since the work of the Kansas survey was limited by the State line. In studying the oil and gas fields of Kansas and Indian Territory,‡ the writer traced to the southwestward the extension of the outcrop of the Fort Scott limestone from the southern border of Kansas into Indian Territory. It extends from west of Chetopa in Kansas to Chelsea, Claremore and Catoosa, and thence to the Arkansas river west of Weer, when it becomes inconspicuous. The horizon as marked by the associated sandstones was followed to a point between Holdenville and

* Amer. Geologist, vol. xx, No. 1, p. 46.

† Article not yet published.

‡ Forthcoming Bulletin U. S. Geol. Survey.

Wewoka. This made possible the correlation of the Kansas section of the Carboniferous with the Indian Territory section thus far worked out by Mr. Joseph A. Taff and the writer.* It appears that there are in the Choctaw Nation 9,000 feet of shales and sandstones above the lowest productive coal, which are lower than the Fort Scott limestone and its equivalent, while in southeastern Kansas there are but 450 feet of shales and sandstones between the Fort Scott limestone and the Mississippian, or Lower Carboniferous. It will be observed that the line of outcrop of the limestone as above traced diagonals the divisions of the Coal Measures as drawn by N. F. Drake† and the horizon extends into the area which he erroneously called Permian.

The results of tracing this horizon strengthened the writer's conviction that similar work in the higher portion of the section would determine the relation of the Red Beds to known formations in Kansas, and in June a trip was made through the Osage Nation into Oklahoma. The previous geological work which had been done in this locality by Drake and by Gould consisted of sections across the rocks and did not permit of accurate correlations.‡ The formation which was selected to be traced is the limestone described in the writer's field notes as the Elk Falls.§ It occurs about 700 feet below the base of the Permian as determined by Prosser. It was chosen because, from its thickness and its relation to the adjacent formations, it was believed that it would be found persistent for a considerable distance southwestward. The line of its outcrop was followed from near Hewins, Kansas, and it was found to pass just west of Pawhuska, where it is the equivalent of the Pawhuska limestone, named by J. P. Smith,|| and mentioned in the sections by Drake and Gould. In southern Kansas, there are two heavy ledges of limestone separated by shales. In the Osage Nation, although it has not been previously so noted, there are three, all of which are persistent as far as the Arkansas river, although considerably thinner southward. The line of outcrop crosses the Arkansas river at Blackburn and continues to Ingalls, where it is the same as the limestones mentioned by Gould in his section made east of that place. Southwest of Ingalls the limestone becomes thinner. Its strike will carry it across the Cimarron river near Perkins. From Ingalls the route followed by the writer was to Ripley and thence to Chandler. In traveling southward, the shales and

* Coalgate Folio, U. S. Geol. Survey.

† Proc. Amer. Philos. Soc., vol. xxxvi, p. 326.

‡ This Journal, March, 1901, p. 185.

§ Vide vol. iii, Kans. Univ. Geol. Surv.

|| Jour. Geol., vol. ii, p. 199.

sandstones associated with the limestones were seen to become gradually redder in color. South of the Arkansas river they are typical Red Beds, In going from Ingalls to Chandler and

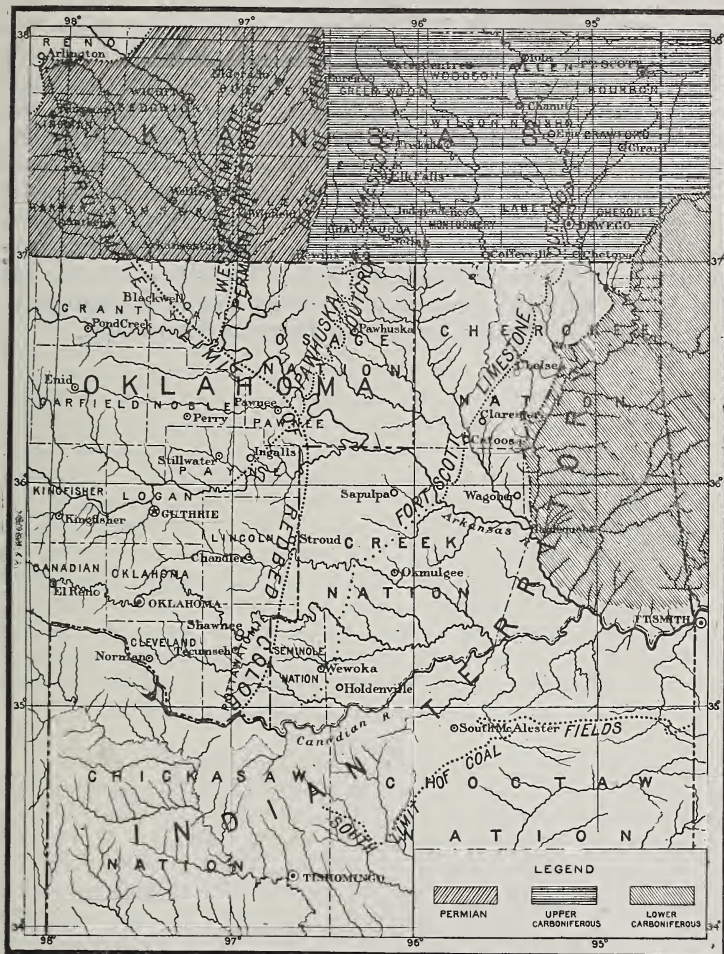

Stroud, one passes over formations which are much lower geologically, and they are likewise red in color.

It appears, therefore, that rocks in Eastern Oklahoma which have been referred to the Red Beds on lithologic grounds, are in part of Upper Carboniferous or Coal Measure age. The sedimentation from the Carboniferous into the Permian is an

unbroken sequence. From what is known of the Permian limestones of Kansas, they will be found, when followed southward, to diminish in thickness, and this change will be accompanied by a transition to more sandy beds. This is in accordance with the observations made by Mr. Gould. The age of that portion of the Red Beds which is in strike with the Permian of Kansas may confidently be expected to be found to be of Permian age. This is in accordance with the evidence already furnished by the vertebrate fossils. Above the Permian limestones in Kansas occur the Wellington shales, which are bluish and greenish gray in color. They are probably represented southwestward by formations which are red. The succeeding formations are typical Red Beds, and have thus far yielded only Permian fossils. Upon the accompanying map (p. 385) the approximate line of transition in color has been drawn with the purpose of showing that it is diagonal to the strike of the Carboniferous and Permian formations.

SCIENTIFIC INTELLIGENCE.

I. CHEMISTRY AND PHYSICS.

1. *A New Method for Producing Aniline and the Analogous Bases.*—It has been found by SABATIER and SENDERENS that free hydrogen, acting at a slightly elevated temperature in the presence of certain finely-divided metals, is capable of attaching itself to the molecules of a number of unsaturated organic compounds, and that this method of hydrogenation is capable of very readily transforming nitro-benzol and analogous nitro-compounds into aniline and the corresponding bases. Copper (prepared by the reduction of its oxide) at a temperature of about 300° to 400° acts rapidly upon a mixture of nitro-benzol and hydrogen, the latter being in excess. The reaction is practically complete, the aniline is almost colorless, and the metal is not altered by continued use. Nickel acts even more readily than copper, and it may be used for this reaction at about 200° ; but it is liable to cause an excessive fixation of hydrogen, for at 250° some ammonia and benzol are formed, while at 300° , with a large excess of hydrogen, methane and ammonia are the chief products. Platinum-black-sponge, and platinized asbestos effect the reduction of nitro-benzol and similar bodies at a temperature of about 230° – 210° . Water-gas or purified illuminating-gas may be substituted for hydrogen in these reductions; in fact, in the case where copper is used, carbon monoxide takes part in the reaction, being oxidized to carbon dioxide to a considerable extent. In view of the cheapness of water-gas, it is expected that this method will find practical application in the manufacture of aniline, in place of the customary reduction in the wet way by means of a metal and an acid.—*Comptes Rendus*, cxxxiii, 321.

H. L. W.

2. *On the Existence of Ammonium.*—An unsuccessful attempt to isolate ammonium has been made by OTTO RUFF. In the first place, potassium iodide was dissolved in liquified ammonia in a cell which branched into two compartments at the bottom, and an electric current was passed through the liquid by means of platinum wires which passed through the bottoms of the two branches, the cell being kept at a temperature of -70° . Under these conditions very small drops of a liquid having a metallic appearance with the color of copper were formed at the negative pole, and these dissolved in the ammonia, giving the intense blue color which potassium-ammonium, KNH_3 , is known to give. Similar experiments were then conducted with ammonium iodide in place of the potassium iodide, but in this case hydrogen was continually given off, and no blue color, nor any other evidence of the formation of ammonium, was observed. The last experiment was repeated with a closed cell so that the evolved hydro-

gen would produce a high pressure; but even at a calculated pressure of 60 atmospheres the appearance of the products did not change. These experiments indicate that free ammonium is incapable of existence even at -70° and at a high pressure.—*Berichte*, xxxiv, 2604.

H. L. W.

3. *A Modified Gooch-Crucible*.—W. C. HERAEUS is manufacturing filtering crucibles, the bottoms of which are made of spongy platinum. This device was suggested to the manufacturer by Dr. Neubauer of Breslau and is called the Neubauer crucible. It is stated that the porous bottom is strong, and that, with reasonable care, precipitates may be scraped off with a spatula. The crucible filters rapidly with a good suction-pump, and yet retains the finest precipitates, such as freshly precipitated barium sulphate and silver chloride. Such exceedingly fine precipitates and gelatinous ones, however, soon form a layer through which the liquid cannot pass, so that this modification has the same limitations in filtering as the ordinary Gooch-crucible where an asbestos filter is used. The Neubauer crucible possesses the disadvantage that it cannot be used for filtering and igniting precipitates which cannot be dissolved out of the porous platinum. It is stated that, on this account, barium sulphate should not be weighed in these crucibles; but, since this substance is readily soluble in hot, concentrated sulphuric acid, there is no doubt that it would present no obstacle to a chemist acquainted with the proper solvent. The advantages of nearly constant weight, and of the possibility of dissolving precipitates in hydrofluoric acid, appear to be the chief reasons for using the new device in preference to the customary one.—*Zeitschr. für angewandte Chemie*, xxxvii, 923.

H. L. W.

4. *Radio-active Lead*.—It has been mentioned previously in this department of the Journal that HOFMANN and STRAUSS have obtained radio-active lead salts from various rare minerals. These authors have recently described further investigations upon the subject, and are still of the opinion that this radio-active substance differs in many respects from ordinary lead in its chemical behavior, but they have not yet obtained it in a pure state. They find that, while the various salts of radio-active lead have nearly the same action upon the electroscope, only the sulphate is capable of acting upon the photographic plate through glass or aluminum; moreover, the sulphate becomes particularly active in the latter respect after having been evaporated with nitric and sulphuric acids, or after having been ignited at 450° for 15 hours with access of air. It appears also, that while radio-active lead sulphate acts more energetically upon the photographic plate than certain polonium (radio-active bismuth) preparations, the latter have a much greater action in discharging the electroscope. The authors believe that it follows from this that the rays detected by photographic means are not identical with those which produce electric discharges.—*Berichte*, xxxiv, 3033.

H. L. W.

5. *A Salt of Quadrivalent Antimony.*—It has been found by WELLS and METZGER that the black, or rather very dark blue, salt, Cs_2SbCl_6 , which was described by Setterberg in 1882 as crystallizing in short prisms, is really octahedral in form, and that it crystallizes isomorphously with Cs_2PbCl_6 , giving crystals of various shades of green when mixed with this yellow salt. The octahedral form is characteristic of a large number of double chlorides of quadrivalent elements, like K_2PtCl_6 ; hence it is probable that Setterberg's salt contains antimony tetrachloride. Attempts were made to prepare SbCl_4 , or to find some evidence of its existence, but without success. It should be black in color, and the oxide corresponding to it should be black also; hence it is probable that the well known oxide SbO_2 , being white, does not correspond to the tetrachloride.—*Amer. Chem. Jour.*, xxvi, 268. H. L. W.

6. *A New Method for the Gravimetric Determination of Tellurium.*—GUTBIER has found that hydrazine hydrate and the salts of this base readily precipitate tellurium quantitatively from solutions of all tellurium compounds, and he highly recommends this method for the determination of this element. The precipitation is made in a nearly neutral or in a hydrochloric acid solution, and the precipitated metal is made flocculent before filtering by boiling the liquid. It is remarkable to notice that the author recommends weighing the tellurium on a paper filter, since the Gooch-filter is far better adapted for the purpose. The test-analyses given are satisfactory.—*Berichte*, xxxiv, 2724. H. E. W.

7. *Diffusion of Hydrogen through Palladium.*—The dependence of this diffusion upon pressure of the diffusing gas is the subject of a study by A. WINKELMANN. It was found that the quantity of hydrogen which diffuses through glowing palladium is not proportional to the pressure of the hydrogen. With diminishing pressure the quantity of gas is greater than this supposition demands. If one supposes that a dissociation of hydrogen occurs, and that the diffusing quantity is proportional to the pressure of the dissociated molecules, then the facts can be sufficiently explained. It is evident on this supposition that only the atom and not the molecule of hydrogen passes through the glowing palladium.—*Ann. der Physik.*, No. 9, 1901, pp. 104–115. J. T.

8. *Cathode Rays.*—The emission theory of these rays appears to be the prevailing one, at least in Germany. W. SEITZ has undertaken a study of the questions, what is the action between the emission particles and the material atoms or molecules in case that the latter can be considered at rest in comparison with the great velocity of the rays, whether one has to deal with frictional forces or conservative forces, and whether attraction or repulsion is exerted. For the study of these questions there appear to be two ways open: the study of reflection and that of the phenomena presented by the passage of the rays through thin membranes. It was found that the cathode rays are dif-

fusively reflected from metal surfaces connected to the earth. With aluminum, zinc, iron, and copper, the maximum of intensity of the reflected rays was displaced toward the mirror. While with platinum, silver, and gold, the reflection was strongest in a direction between that of the incidence ray and the normal to the metal surface. In the case of the first class of metals the reflection increases with the angle of incident; and with the last class diminishes. At perpendicular incidence the reflective power increases with the atomic weight. Zinc departs slightly from this law. The absorption of cathode rays in thin plates is independent of the tension. The absorption-coefficient increases with the thickness of the window through which the rays pass. Lenard's law that thin plates of different metals, having equal masses per unit of surface, absorb the same fraction of the incident rays, is only a first approximation. The increase of the absorption-coefficient, with the thickness of the window, cannot be explained by the assumption that the electrons lose their velocity by friction with the molecules and are then absorbed, for no difference is observed between the magnetic and electric deflection of the rays in the case where they pass direct from the cathode, or in the case where they have passed through an aluminum window. Moreover, the rays emerging obliquely from the window behave in the same manner as those emerging along the normal to the window. The following values were obtained:

$$v = 0.703 \cdot 10^{10}; \quad \frac{e}{m} = 0.645 \cdot 10^7. \text{—} \textit{Ann. der Physik}, \text{ No. 9, 1901,}$$

pp. 1-33.

J. T.

9. *Photography of the Infra-Red Spectra of the Alkali-metals.*

—H. LEHMANN describes the method of sensitizing plates for the red portion of the spectra, and adopted Burbanks' sensitizing bath, which is constituted as follows :

Distilled water	160 ^{cm}
Cyanine solution (Burbanks)	1 ^{cm}
Ammonia (sp. gr. 0.91)	1 ^{cm}
Silver nitrate (1 : 40)	5 drops

This enabled the author to photograph the spectra of glowing metallic paper as far as 1000 $\mu\mu$. The arrangement of spectrum apparatus is fully described. Five new lines of rubidium and nine of caesium were discovered.—*Ann. der Physik*, No. 7, pp. 633-658.

J. T.

10. *Ether and Gravitational Matter through Infinite Space.*—

In the course of an article on this subject, LORD KELVIN thus remarks upon the old hypothesis that if we could see far enough into space the whole sky would be seen occupied with discs of stars all of perhaps the same brightness as our own sun, and that the reason why the whole of the night sky and day sky is not as bright as the sun's disc, is that light suffers absorption in traveling through space.

"Now we have irrefragable dynamics proving that the whole life of our sun as a luminary is a very moderate number of million of years, probably less than 50 million, possibly between 50 and 100 million! To be very liberal, let us give each of our stars a life of a hundred million years as a luminary. Thus the time taken by light to travel from the outlying stars of our sphere to the center would be about three and a quarter million times the life of a star. Hence if all the stars through our vast sphere commenced shining at the same time, three and a quarter million times the life of a star would pass before the commencement of light reaching the earth from the outlying stars, and at no one instant would light be reaching the earth from more than an excessively small proportion of all the stars. To make the whole sky aglow with the light of all the stars at the same time the commencement of the different stars must be timed earlier and earlier for the more and more distant ones so that the time of the arrival of the light of every one of these at the earth may fall within the durations of the lights at the earth of all the others."—*Phil. Mag.*, August, 1901, pp. 161-177. J. T.

11. *Nineteenth Century Cloud over the Dynamical Theory of Heat and Light.*—LORD KELVIN classifies these clouds as follows: Cloud I. Relative motion of ether and ponderable bodies. Lord Kelvin discusses the various theories in regard to the constitution of the ether, and in the course of this discussion remarks upon the suggestion of Fitzgerald and of Lorenz, that the motion of ether through matter may slightly alter its linear dimensions—"according to which if the stone slab, constituting the sole plate of Michelson and Morley's apparatus, had in virtue of its motion through space occupied by the ether, its linear dimensions shortened one one-hundred-millionth in the direction of motion—the result of the experiment would not disprove the free motion of ether through space occupied by the earth." The author still regards cloud I as very dense. Cloud II arises from a proposition first enunciated by Waterston, which is as follows:

"In mixed media the mean square molecular velocity is inversely proportional to the specific weight of the molecule. This is the law of the equilibrium of *vis viva*." Without any knowledge of the paper of Waterston, Maxwell, in 1859, enunciated the following proposition: "Two systems of particles move in the same vessel: to prove that the mean *vis viva* of each particle will become the same in the two systems." This is also Waterston's proposition regarding the law of partition of energy. Lord Kelvin does not regard either the proof of Waterston or that of Maxwell successful. The subsequent theorems of Boltzmann and Maxwell in regard to the equality of mean kinetic energies, are also criticised. Lord Kelvin, after an exhaustive criticism of the Boltzmann and Maxwell law, quotes Lord Rayleigh's remarks on the difficulties connected with the application of the law of equal partition of energy to actual gases (*Phil.*

Mag., Jan., 1900), and remarks upon the sentence, "What would appear to be wanted is some escape from the destructive simplicity of the general conclusions." "The simplest way of arriving at this desired result is to deny the conclusion, and so, in the beginning of the twentieth century, to lose sight of a cloud which has obscured the brilliance of the molecular theory of heat and light during the last quarter of the nineteenth century."—*Phil. Mag.*, July, 1901, pp. 1-40. J. T.

12. *The Resistance and Electromotive forces of the Electric Arc*.—W. DUDELL has carried on a series of experiments having as their object the measurement of the resistance of the electric arc under various conditions, as also of the electromotive forces present. The method adopted involved the use of a steady current to which a testing current of high frequency (120,000 periods per second) was added. The measurements of impedance and the power factor were made by the three voltmeter method, employing (1) an alternator for high frequency; (2) a new, very delicate instrument, called a "thermo-galvanometer," to measure the three voltages and (3) a standard resistance for comparison of the impedance of the arc, having a time constant of only 2.7×10^{-7} second.

Some of the results obtained are as follows. The true resistance of an arc 3^{mm} long between 11^{mm} solid carbons, through which a 9.91 ampere current was flowing, was 3.81 ohms. The whole difference of potential was 49.8 volts, of which 37.8 was accounted for by the ohmic drop, the real E.M.F. opposing the flow of current being 12 volts. With cored carbons the resistance was found to be 2.54 ohms and the back E.M.F. 16.9 volts. With increase of the direct current the back E.M.F. first decreased and then increased, the minimum value being 11.3 volts for 6 amperes. With the direct current constant, increase of arc length increased the resistance. Further the composition of the electrodes was found to have great influence on the resistance and back E.M.F. Thus with direct current and arc length constant, soaking the solid carbons in potassium carbonate reduced the resistance from 3.81 to 2.92 ohms and increased the back E.M.F. from 12 to 15.6 volts. It is suggested that perfectly pure carbons would probably make the resistance so great that the maintenance of the arc would be impossible, traces of impurities being essential.

The author concludes that the arc resistance consists of three parts; thus, for the case above noted, of (1) the resistance at or near the contact of the positive electrode and the vapor column of 1.61 ohms; (2) the resistance of the vapor column of 2.5 ohms; (3) the resistance between the latter and the negative carbon of 1.18 ohms. The back E.M.F. consists of two parts located at or near the contact between the electrodes and the vapor column. That at the positive electrode, about 17 volts, opposes the flow of the direct current, while that at the negative electrode, about 6 volts, helps the flow of the direct current, i. e., is a forward E.M.F.

The greater part of these two E.M.F.'s are considered as due to thermo-electric forces, and special experiments are noted which support this view.—*Proc. Roy. Soc.*, No. 450, p. 512.

13. *Unsolved Problems in Low-Temperature Research.*—An essay by Miss AGNES M. CLERKE, author of "A Popular History of Astronomy during the Nineteenth Century," upon Low-Temperature Research at the Royal Institution of Great Britain, 1893-1900, has recently been issued. It gives an admirably clear and complete summary of this most interesting subject, and closes with the following chapter.

"The development of low-temperature chemistry is one of the most striking features of scientific history during the last decade of the nineteenth century. Many questions of profound interest have been answered through its means, and a partial insight has been gained into some of the most recondite secrets of nature. The unique condition attends it, that the *ne plus ultra* cannot recede as it advances. The absolute zero forms an irremovable landmark, a boundary line that may not be transgressed, an asymptote, as it were, to the curve of future progress. And every step nearer to it is harder to take than the previous one. Among many causes of augmenting difficulty is the circumstance that the molecular latent heats of vaporization diminish with the absolute boiling point. Hence, a continually more lavish expenditure of frigorific material is necessitated, and of material the price of which, in money and labor, rises rapidly with its frigorific efficacy. Still, although the bottom of the temperature-scale may never be actually reached, the intervening space will surely be much abridged. But we shall never, it is safe to predict, assist at the 'death of matter.' At the stage arrived at, there is no sign of its being moribund. Forces still act within and upon it. Gravity and cohesion maintain their normal power. It sensibly impedes the passage of electricity in the purest and most highly conducting metals. Its minute particles can take up and modify luminous vibrations. Only chemical affinity seems to be extinct; the various species of matter cease to react upon each other. The next cryogenic achievement, it is true, may alter the situation as we now see it. Our present standing-ground may be subverted, for the inquiry is just now in a critical phase. The liquefaction of helium, for example, may prove decisive of many things—it may set at rest some doubts, and raise unlooked-for issues.

The conditions for its accomplishment were clearly set forth in the Bakerian Lecture. They may be realized by the use of methods actually available. This last fortress of gaseity cannot be regarded as impregnable, although its capture will be at a high monetary cost. Gaseous helium, to begin with, is of the utmost scarcity; and what is scarce demands outlay to procure. Its condensation can be effected only by subjecting it to the same process that succeeds with hydrogen, substituting, however, liquid hydrogen under exhaustion for liquid air as the pri-

mary cooling agent. As the upshot, a liquid will be at hand, boiling at about 5° absolute, or -268° C., but more expensive than liquid hydrogen, in a much higher ratio than liquid hydrogen is more expensive than liquid air. By comparison, 'potable gold' would be a cheap fluid. Nor could the precious metal, in that, or any other form, be employed for a higher intellectual purpose than in promoting and extending researches of such boundless promise and commanding interest as those conducted at the Royal Institution."

II. GEOLOGY AND MINERALOGY.

1. *Geological Survey of Canada*. G. M. DAWSON, Director. Annual Report (New Series) Vol. XI. Reports A, D, F, G, J, L, M, S, for 1898. Pp. 853, 20 plates and figures in text, 7 maps. Ottawa, 1901.—The first of these, the Summary Report of the Director, has already been mentioned in these pages.

Report D on the Yellowhead Pass Route is by James McEvoy. The region traversed extends from Edmonton and Strathcona on the north, Saskatchewan River westward to the Athabasca River valley, and thence up through the Yellowhead Mountain pass and into the Frazer River valley, ending at Tête Jaune Cache. The formations, their names and correlations, are as follows, viz :

Tertiary	Paskapoo beds	} Laramie.
Cretaceous	{ Edmonton beds	
	{ Pierre and Fox Hill.	
Devono-Carboniferous.		
Cambrian	{ Castle Mountain group.	}
	{ Bow River series.	
Archean	Shuswap series.	

D. B. Dowling, in F and G, reports on the Geology of the West shore and Islands of Lake Winnipeg (F), and on the East shore of Lake Winnipeg and adjacent parts of Manitoba and Keewatin, from personal surveys and supplemented by notes made by his predecessor, J. B. Tyrrell. The formations recognized are compared with those described in the Geology of Minnesota, Vol. III. The correlations are as follows, viz :

? Utica	Stony Mountain formation = Richmond Group.
Trenton	{ Upper Mottled limestone = Maclurea beds.
	{ Cat-head limestone = Fusispira and Nematopora beds.
	{ Lower mottled limestone = Clitambonites beds.
? Black River	Winnipeg sandstone and shales.

Collections of fossils from some of these formations have already been described by J. F. Whiteaves in *Paleozoic Fossils*, Vol. III, Parts II and III.

R. W. Ells contributes report J on the Geology of the Three Rivers Map-Sheet, Quebec. North of the St. Lawrence the Potsdam, Calciferous, Chazy, Black River and Trenton formations are recognized. Lists of the fossils collected from them are reported by H. M. Ami. The "Medina" outlier south of the St. Lawrence is defined.

A. P. Low reports (L) on the South shore of Hudson Strait and Ungava Bay. The rocks there met with are ancient crystallines, igneous intrusions, altered shales and schists, dolomites and iron ores, the latter possibly of Cambrian age.

Robert Bell contributes report M on the topography and geology of the northern side of Hudson Strait. The fossiliferous rocks are of Trenton and Niagara age, and Devonian fossils are reported from the southern side of Southampton island. A remarkable feature in the geology on the north shore of the strait are the twelve bands of white crystalline limestone alternating with bands of gneiss. Dr. Bell estimates the total thickness of these limestones to be not less than 30,000 feet. Lists of the plants of Hudson Strait and of the Lepidoptera of Baffin Land are appended.

The closing reports are R, The Report of the Section of Chemistry and Mineralogy, by G. Christian Hoffmann, and S, The Report of the Section of Mineral Statistics and Mines by E. D. Ingall.

H. S. W.

2. *Geological Survey of Canada.* ROBERT BELL, Acting-Director. *Catalogue of the Marine Invertebrata of Eastern Canada*; by J. F. WHITEAVES; pp. 1-271. Ottawa, 1901.—The Catalogue is a report on the present state of our knowledge of the marine invertebrata of the Bay of Fundy, Atlantic Coast of Nova Scotia, and gulf and mouth of the River St. Lawrence, as far as the Strait of Belle Isle.

H. S. W.

3. *Geological and Natural History Survey of Minnesota, 1900-1901.* Vol. VI of the Final Report. *Geological Atlas with Synoptical descriptions*; by N. H. WINCHELL. 88 geographical and geological plates with accompanying descriptive text.—In this closing volume of the survey, begun twenty-eight years ago, the author offers the following as his final classification of the geological formations of the State of Minnesota:

Cretaceous	{	Ft. Pierre
		Niobrara
		Ft. Benton
		Dakota.
Devonian	{	Hamilton
		Marcellus?
		Corniferous.
Lower Silurian	{	Hudson River
		Galena.
		Trenton.

Upper Cambrian	{ St. Peter Shakopee Richmond Lower Magnesian Jordan St. Lawrence } St. Croix Series. Dresbach } Hinckley sandstone, passing down into	
Taconic	{ Potsdam Red sandstone, interbedded with Manitou Lavas, and Potsdam Quartzite (at New Allen) Middle and the Puckwunge Conglomerate } Cambrian. Cabotian (igneous) Red Rock Apobsidian red granite Gabbro and its varieties and Lavas } Lower Animikie } Cambrian. Slates and Quartzite Taconite and Quartzite	
Archean	{ Granite, Syenite, etc. Laurentian. Crystalline schists and gneiss Couthiching. Various fragmentals } Kawishiwin Greenstone } Keewatin.	

4. *Iowa Geological Survey*. Vol. XI. Administrative Reports. SAMUEL CALVIN, State Geologist. Pp. 1-579. Pls. i-xii, figures 1-43. 9 maps. Des Moines, 1901.—This volume carries forward the detailed Survey of the State of Ohio by the present staff of geologists to cover the counties of Louisa, Marion, Pottawatamie, Cedar, Page, Clay and O'Brien. In the report on Cedar County we note that Professor Norton transfers the Coggan formation from the Silurian, to which it was previously referred, to the Devonian system, with which it is more naturally referred by its few though diagnostic fossils.

H. S. W.

5. *Dragons of the Air, an account of Extinct Flying Reptiles*; by H. G. SEELEY; pp. 1-232, and 80 illustrations. London, 1901 (Methuen & Co.).—The close kinship between a fascinating novel and a well-written popular book of science is illustrated by Professor Seeley's story of the "Dragons of the Air." A thorough grasp of the scientific facts in the case is united with a rare power of imagination and of pictorial description, which would have served the historical novelist as successfully as it has the paleontologist in the present case. The sense of the marvelous is used legitimately at the outset by introducing the mythical dragons and angels, and finding even greater anomalies in the actual wings of fish, frogs, lizards, squirrels and cats, and teeth in birds and beaks in reptiles and mammals.

H. S. W.

The Ornithosaurs, the scientific name of these flying dragons, are not described in order to magnify the oddities of nature, but the author has sought to show the natural affinities of a most

peculiar group of organisms to those living and more familiar types of structure, the reptiles, birds and mammals. Step by step the peculiarities of the structure of the rare bones are compared with known structures in other animals. The reconstructions made become understood and real and reasonable; and the reader, though unfamiliar at the outset with the technical names, leaves the book with a new vocabulary which means something real to him. While extremely skillful in picturing his own conceptions of the animals represented by the fossils studied, the author is also precise and scientifically accurate. Whatever criticism may be made of his classifications or of the affinities assigned, the reasons for them are definitely based upon the observed facts. The Ornithosauria are traced for origin not directly to reptiles or birds, as now known and defined, but rather to unknown ancient stock, in which were combined rudimentary characters which, by elimination of some and modification of others, have resulted in the differentiations represented by the Reptilian, Bird, Ornithosaurian and Mammalian types.

"If we ask," the author writes, "what started the Ornithosaurian into existence, and created the plan of construction of that animal type, I think science is justified in boldly affirming that the initial cause can only be sought under the development of patagial membranes such as have been seen in various animals ministering to flight." But there was "no geological history of the rapid or gradual development of the wing finger, and although the wing membrane may be accepted as its cause of existence, the wing finger is powerfully developed in the oldest known Pterodactyles as in their latest representatives." "Pterodactyles show singularly little variation in structure in their geological history," and what there was has to do chiefly with loss of characters early possessed or variations in size and parts.

Regarding the affinities of the Ornithosaurs the author remarks, "It would therefore appear from the vital community of structures with Birds, that Pterodactyles and Birds are two parallel groups, which may be regarded as ancient divergent forks of the same branch of animal life, which became distinguished from each other by acquiring the different condition of skin, and the structures which were developed in consequence of the bony skeleton ministering to flight in different ways; and with different habit of terrestrial progression this extinct group of animals acquired some modifications of the skeleton which Birds have not shown. There is nothing to suggest that Pterodactyles are a branch from Birds, but their relation to Birds is much closer, so far as the skeleton goes, than is their relation with the flightless Dinosaurs, with which Birds and Pterodactyles have many characters in common." The book will prove as useful to the paleontologist as to the general reader, for it furnishes a brief but clear and systematically arranged compendium of the chief facts known regarding this unique group of extinct animals.

The illustrations are not the least important feature of the

book. They furnish a definite idea of the morphology of these animals, however much of this idea may have been contributed by the author.

H. S. W.

6. *Contributions to Mineralogy and Petrography from the Laboratories of the Sheffield Scientific School of Yale University*; edited by S. L. PENFIELD and L. V. PIRSSON. Pp. 482, 8vo. New York, 1901 (Charles Scribner's Sons).—This volume forms one of the series of Yale Bicentennial publications mentioned in the last number (p. 321). It is devoted to the mineralogical and petrographical work of the University. Part I, edited by Professor Penfield, opens with an interesting summary of the development of mineralogy at New Haven from the appointment of Professor Benjamin Silliman in 1802 to the present time; the record of work accomplished and of the influence thus exerted on the progress of the science in the world is a remarkable one. A bibliography follows including some two hundred and twenty-five titles of papers and books published since 1849. A list is also given of the new species described, thirty-six in number, and of species whose chemical composition or crystallization has been established. The bulk of the volume, pp. 30–377, is given to selected papers reprinted largely from the pages of this Journal. The first of these is the one by Prof. G. J. Brush on American Spodumene; among others are the Branchville papers by Brush and Dana, and numerous important researches chiefly by Penfield and his students.

Following the mineralogical part of the volume is Part II, pp. 381–480, devoted to petrography. This includes a brief history of the department and nine reprinted papers; this portion of the volume has been edited by Professor L. V. Pirsson.

✓ 7. *On a large Phlogopite Crystal*; by W. HARVEY McNAIRN. (Communicated.)—A crystal of phlogopite, of unusual and probably unexampled size, was discovered in a mica mine near Sydenham, Frontenac Co., Ontario, at a depth of about 30^m. The vein, which occurs in pyroxenite, is about 10^m wide and consists of mica imbedded in pyroxene. Next to the hanging wall there is a layer of calcite enclosing and occasionally replaced by apatite. On the other side there occurs a dark green, cleavable pyroxene which gradually changes into the pyroxenite. The crystal traversed the vein from S.W. to N.E. in an approximately horizontal direction. It was a clear, dark colored, amber phlogopite of an excellent quality for electrical purposes. The outline of the cross-section was roughly hexagonal and it had the spindle shape frequently observed in elongated crystals of the micas. At the point measured, which was slightly past the greatest diameter, the cleavage face was 1.5^m × 2^m, and at that time about 5^m of the total length had been removed. As far as one could tell there was a considerable amount still left in the matrix. Sheets of the full size, however, were not available as the crystal was divided longitudinally by a parting which joined two diagonally opposite corners.

University of Toronto.

8. *Handbuch der Mineralogie*; von Dr. CARL HINTZE. Erster Band, sechste Lieferung, pp. 801-960. Leipzig, 1901.—The sixth part of Vol. I of Hintze's Mineralogy (part eighteen of the whole work) has recently been issued. It contains descriptions of the sulphides of the pyrite, marcasite and chalcopyrite groups.

III. MISCELLANEOUS SCIENTIFIC INTELLIGENCE.

1. *Meteorite Swarms*.—The results of an investigation into the probabilities of the existence of meteorite swarms, their petrographic nature, and their relation if any to known star showers, are given in a recent paper* by A. G. HÖGBOM. For this investigation the meteorite falls of known date were plotted according to the day of the month and the petrographical nature of each as given by Wülfing. Some groupings seemingly significant were thus disclosed. Thus of the nine known Howardites, three are found to have fallen during the first days of August and three during the first half of December. The probabilities against such a grouping being a mere coincidence are stated to be several thousand to one.

Of the three known Eukrites two fell June 13-15. According to the author the chances are as 90 to 1 that these had a common origin.

Of the fifteen known "Crystalline Chondrites" four fell March 19-25; three Sept. 16-24, two May 22-27, two Aug. 8-15 and four were variously distributed. Of fifteen "Intermediate Veined Chondrites" three fell April 9-12. These correspond in date with the star shower of the Lyrids.

With respect to other groups of Chondrites, groups depending in Brezina's or Wülfing's classification on the presence or absence of such features as vein structure or brecciated structure, the author states that he regards such characters not suitable for the distinction of meteorite swarms. The same opinion is expressed regarding minor differences of chemical composition, since this may vary in one and the same mass. With the December Howardites meteorites of the types of Bustite, Chladnite and Amphoterite have a common date of fall. A Chladnite, a Howardite and a Howarditic Chondrite have the same date of fall with the June Eukrites. A Chassignite, two Howarditic Chondrites and a Howardite have the first of October as a common date fall. The iron meteorites of known date of fall are also found to have dates approaching those previously traced. Of the eight known, one fell near the time of the August and one that of the December Howardites; one has the same date and is only two years later than the Howardite of July 14, and one (or two) is associated with the Howarditic Chondrite and Chladnite of

* Bulletin of the Geol. Inst. of the University of Upsala, vol. v, Part I, No. 9, pp. 132-143.

the last of March. Also the single known Lodranite which closely resembles an iron meteorite accords in its time of fall with the Howardites and related types of the first of October.

If any ground has thus been established for believing that meteorites of the same approximate date of fall have a common origin, then the constitution indicated for some of the swarms at least is that of a combination of a rock rich in anorthite with one rich in iron. It is suggested that these types have arisen by differentiation of a common magma, such as has occurred in some ultra-basic terrestrial magmas. The regularly varying composition of moldavite is referred to as an illustration of such differentiation.

Lines connecting dates of falls through succeeding years are found for the most part to incline to the left, showing that the swarms are met continually earlier by the earth. This is shown to be what might be expected through the deformation of a swarm by the earth's attraction. Little or no connection of meteorite swarms with known star showers is observed. The meteorite falls reach their maximum in number the middle of June and their minimum the last of October.

On the whole the probability of the existence of meteorite swarms which are met by the earth at recurrent dates in its yearly revolution is shown to be considerable and the careful record of the date of fall of as many meteorites as possible is urged for purposes of further investigation. O. C. F.

2. *The American Philosophical Society.*—The American Philosophical Society of Philadelphia announces, in a circular dated October 16, that it will in future, in addition to its usual semi-monthly meetings, hold at least one general meeting in each year. For 1902 it has been decided that this general meeting shall be held in Easter week. Members desiring to present papers, either for themselves or others, are requested to send to the secretaries at as early a date as practicable and not later than February 15th, 1902, the titles of the papers, accompanied by a brief abstract, so that they may be duly announced on the program which will be issued immediately thereafter and which will give in detail the arrangements for the meeting. The publication committee, under the rules of the Society, will arrange for the immediate publication of the papers presented. A general committee of twenty-six gentleman from different parts of the country has the whole matter in charge. Professor George F. Barker is the Chairman and Mr. I. Minis Hays, Secretary.

The circular, in remarking upon the national character of this venerable Society—founded in 1743—expresses the expectation that this general meeting “from the information to be derived from the papers presented and their discussion by those most competent to add to our knowledge, will attract the members of the Society from all parts of the country to their mutual advantage as well as to that of this, the first and oldest scientific society in America, and one of the oldest in the world.”

THE

AMERICAN JOURNAL OF SCIENCE

[FOURTH SERIES.]

ART. XLIII.—*Geology of the Little Colorado Valley* ;* by
LESTER F. WARD.

THE geology of the Grand Canyon region of northern Arizona has received much attention on the part of geologists and considerable has been written on the higher beds of Mesozoic age that lie to the eastward in Marble Canyon and farther north, but very little study seems to have been made of the Little Colorado Valley above the point at the north end of the Colorado Plateau, where it broadens out into a plain. The strata of the Grand Canyon up to and including the junction of the Little Colorado with the Colorado River, consist, as all know, entirely of Paleozoic and pre-Paleozoic rocks, and it is the Carboniferous limestones, or sometimes sandstones (Upper Aubrey), that occupy the surface of both the Colorado and the Kaibab plateaus. But the entire system dips sensibly to the northeast and at any point some distance back from the canyon remnants of Mesozoic rocks occur for many miles before reaching the bed of the Little Colorado. That river, therefore, practically flows for almost its entire length over Mesozoic strata, but these do not attain their great development except on the northeastern slope of the valley. Here they form several series of terraces, rising one above another as one recedes from the river, and forming at their maximum development lofty and picturesque escarpments, with brilliantly colored stratification, rivaling in many respects the Grand Canyon itself. The broad arid plains that lie to the southwest of these cliffs have received the name of the Painted Desert, from the circumstance that from any point on this desert these painted cliffs are always in full view. From a great distance they may

* Published by permission of the Director of the United States Geological Survey.

under certain conditions appear beautiful and innocent, but any attempt to invade this desert or to scale these cliffs, except by means of the few well known Indian trails, is certain to be met with defeat, and the hardships that have to be endured in striving to traverse this region are of the severest kind. Lieut. Ives described the region in the following language :

“The scene was one of utter desolation. Not a tree nor a shrub broke its monotony. The edges of the mesas were flaming red, and the sand threw back the sun’s rays in a yellow glare. Every object looked hot and dry and dreary. The animals began to give out. We knew that it was desperate to keep on, but felt unwilling to return, and forced the jaded brutes to wade through the powdery impalpable dust for fifteen miles. The country, if possible, grew worse. There was not a spear of grass, and from the porousness of the soil and rocks it was impossible that there should be a drop of water. A point was reached which commanded a view twenty or thirty miles ahead, but the fiery bluffs and yellow sand, paled somewhat by distance, extended to the end of the vista. Even beyond the ordinary limit of vision were other bluffs and sand fields, lifted into view by the mirage, and elongating the hideous picture. The only relief to the eye was a cluster of blue pinnacles far to the east that promised a different character of country. It was useless, however, to take the risk of proceeding directly thither. The experience of the day had demonstrated the hopelessness of trying to drive the mules for any length of time through an untrodden and yielding soil, and it was determined, as a last chance, to go back to Flax River and ascend the bank, at the hazard of having to make a long circuit, till some Indian trail should be encountered leading in the desired direction, and affording a beaten way practicable to be followed.”*

Very little seems to be known of the more detailed nature of these deposits. They are usually spoken of as a single great system of beds, and I am not aware of any serious attempt to subdivide them or arrange them into anything like a successive series of varying deposits. It was my chief object during my entire stay in that country to subject these deposits to a searching analytical study and to work out, if possible, their true succession. I began this study by a reconnaissance of the Little Colorado Valley. After making camp at Tanner’s Crossing, which is only 12 miles above the point where the Little Colorado enters the limestone canyon at the foot of Coconino Point, I set about mastering the details of the stratigraphy of that general region. Later on, and in the

* Report upon the Colorado River of the West, explored in 1857 and 1858 by Lieutenant Joseph C. Ives, Washington, 1861, Part I, p. 117.

light of information thus obtained, I studied the various remnants of the Mesozoic that are scattered over the Colorado Plateau, and especially Red Butte, which is the most conspicuous and best known of these remnants. Finally, as a concluding task, I returned to the upper portion of the valley of the Little Colorado and made a study of the formation there similar to that which I had made below.

I will not introduce here the details of this investigation and shall be obliged to omit a great amount of important data, including many sections recorded in my note-book, but I will merely give the most general and essential results and the general section.

First of all, let me say, that I think I have succeeded in dividing the formation into three entirely distinct series or classes of deposits. One of these, the thickest of them and the one which is best known, has already been named by Major Powell the Shinarump.* This, however, occupies the central portion of the beds in their geological sequence. The other two divisions are, so far as I am aware, unnamed and I have ventured to give names to them. The lower beds I, therefore, designate as the Moencopie beds, from having first found them in their full development at the mouth of the Moencopie Wash. To the other or highest of the series I have thought it appropriate, from the considerations already set forth, to give the name of Painted Desert beds.†

The Moencopie Beds.

These occupy the lowest portion of the formation, having a maximum observed thickness of between 600 and 700 feet. They present several distinct phases, but the greatest part of them consists of dark reddish brown, soft, laminated, argillaceous shales, nearly destitute of silica, highly charged with

* Geology of the Uinta Mountains, etc., 1876, pp. 68-69. See Twentieth Ann. Rep. U. S. Geological Survey, Pt. II, p. 318.

† The name "Painted Desert" occurs, apparently for the first time, in the contents to Chapter IX of Part I of Lieut. Ives's Report upon the Colorado River of the West, pp. 15 and 113, but is not used in the description of the desert on pp. 116-117, from which the above extract is taken. It is used by Dr. Newberry in Part III, on pp. 76-83, and to it he devotes a section. These early uses of the term show that it refers to an area lying opposite to the region between Wolf's Crossing and Winslow, but Dr. Newberry says (p. 76) "that the peculiar physical aspect and geological structure of the Painted Desert prevail over a wide belt of country bordering the Little Colorado on the east, and extending at least as far northward as our Camp 73." This camp appears from the very imperfect map accompanying the report to have been about on the latitude of Tanner's Crossing, but far to the westward. On this map the Painted Desert is represented as occupying all that region lying along the southwestern base of the painted cliffs from the line of their route through the gap at Blue Peaks and Pottery Hill northwestward to an indefinite distance. On the latest Land Office maps, however, it seems to be restricted to that portion of the desert lying north of the Moencopie Wash and along the base of Echo Cliffs. There seems to be no good reason for thus restricting it.

salt* and gypsum, tending on exposure to assume the character of nearly homogeneous marls and to form low ridges, buttresses and even isolated knolls or buttes, at the bases of cliffs and in eroded valleys. The gypsum often forms thin sheets which appear as fine white lines and which do not follow the planes of stratification but cross the beds irregularly and also cross one another, giving the exposures a peculiar striped appearance.

Between these beds of shale there occur, usually at more than one horizon, brown sandstones. These are more or less argillaceous and their exposed faces do not present sharp angles but have rounded forms, due in the main to the influence of winds which wear off the jagged appearance but do not tend to form chimneys or assume fantastic shapes. These sandstone ledges, which are very uniform in composition, sometimes have a thickness of 100 feet or more, though such heavy beds are usually interrupted by several layers of the shale.

Toward the lower part of the Moencopie beds the shales gradually become calcareous and there is in nearly all good exposures a horizon of white impure limestone, well laminated in its central portion, but becoming very thin and hard below and finally passing either into the typical shale or into homogeneous marls. The extreme upper and also the extreme lower portions of the Moencopie beds always consist, so far as observed, of the typical dark brown argillaceous shale, and the whole series, wherever the contact can be found, always rests in marked unconformity upon the underlying Paleozoic rock (Upper Aubrey).

* An artesian well was bored at Adamana on the Santa Fe Pacific railroad, eight miles north of the Petrified Forest and in the valley of the Rio Puerco. At a depth of 305 feet water was struck which had sufficient force to rise 19 feet above the surface and discharge 25 gallons per minute. The water was very salt, reported at 3 per cent.-chloride of sodium, so as to be wholly unfit for any use. Mr. James Swainson, in charge of the work, which was done by the American Well Works of Aurora, Ill., was good enough to send me the "log" (record of boring), which is as follows:

	Feet.
Surface sand and adobe	55
Sandstone	3
Cement gravel	1
Sandstone	29
Water at 88 feet only slightly salt.	
Sandstone	20
Brown shale	43
Red shale	49
Hard brown and blue shale	5
Red shale	70
Sandstone	10
Hard brown shale	20
Intensely salt water at	305

The lower 200 feet of this section clearly belong to the Moencopie beds.

The Shinarump.

This constitutes a vast series with a maximum observed thickness of at least 1600 feet. It presents a number of phases, some of which are so distinct that if studied in only one locality they would naturally be regarded as separate subdivisions, but such a general survey as I have been making points to a certain homogeneity in all these beds, or at least establishes the unmistakable tendency towards the recurrence in any of the phases of features that are prominent in other phases. The Shinarump constitutes the horizon of silicified trunks and there is no part of it in which fossil wood does not occur in great abundance. It also marks the limit of the wood-bearing deposits of this region. For this reason alone, in view of the etymology of the name, I should be justified in extending the Shinarump as far as the fossil trunks occur, and it is obvious from the language used that Major Powell had the upper portions of the formation in view as well as the lower when giving the name, although other geologists in speaking of the Shinarump usually seem to have in mind only those beds which I include under the conglomerate. It is doubtful, however, whether the remainder of the formation has really been studied or carefully observed by others, and I fancy that in dealing with it I am entering upon a sort of geological *terra incognita*.

The Shinarump Conglomerate.—I am using this expression, which is the one most commonly found in works that treat of these beds, in a somewhat comprehensive sense, the necessity for which will be apparent. As thus used this part of the Shinarump occupies the lower half of that series and has a maximum thickness of 800 feet. Although perhaps the most prominent feature of it is the so-called conglomerate, which sometimes is in truth deserving of that name, and contains somewhat large but always well-worn pebbles and cobbles derived from underlying formations, still, it rarely happens that this aspect of the beds constitutes the major portion of them. In the first place the conglomerate tends to shade off into coarse gravels and then into true sandstones. These sandstones are of a light color, contrasting strongly with the dark brown sandstones of the Moencopie beds already described. They are, moreover, always more or less cross-bedded and usually exhibit lines of pebbles running through them in various directions. These are true sandstones, very hard, devoid of alumina, and scarcely affected by the winds, so that their angles are usually sharp and the ledges they form are abrupt and jagged. Although the sandstones proper generally occur lower down, still, there is no uniformity in this arrangement, and sandstones are often found in the middle and con-

glomerates more rarely at the top. But in addition to these the Shinarump Conglomerate embraces other classes of beds. There is a well-stratified layer of thinnish sandstone shales that is often seen immediately under the heavy sandstone cap. Some of these shales have a grayish color and are highly argillaceous. These layers tend to thicken even within the formation itself, but especially farther out, and what is more significant, they often become transformed into a bluish white marl. This condition can be seen between the beds of conglomerate in places where the Shinarump Conglomerate is comparatively thin, as in the lower valley of the Little Colorado, where it is only about 300 feet in thickness. This feature is not very prominent, but at other places, as in the Petrified Forest region where the Shinarump attains its maximum thickness of 700 or 800 feet, this tendency on the part of certain beds to become transformed into marls is the most marked feature of the formation. The marls here occupy much more than half of the beds. They are very varied in color, showing besides the white and blue tints a great variety of darker ones such as pink, purple, and buff. These heavy marl beds, of which there may be several in the same cliff, are interstratified between conglomerates, coarse gravels, and cross-bedded sandstones, all of which taken together form the beautifully banded cliffs that are seen throughout the Petrified Forest, and especially along its northern flank. It thus becomes necessary to include under one designation all of these varying beds, which often change the one into the other even at the same horizon within short distances, and rather than adopt a new name I have preferred to call them all the Shinarump Conglomerate.

It remains to mention certain minor features, which are not universal, but which, nevertheless, have considerable importance. In the lower Little Colorado Valley there occur numerous somewhat calcareous clay lenses, the lime taking the form of bright white stripes, while the clay is usually purple or pink. These are very distinct objects and vary in size from lenses 10 or even 20 feet in length to small lenticular blocks or somewhat oval or even spherical clay balls or pellets. These calcareous clay inclusions are scarcely seen farther to the southeast, but on Red Butte they are well marked and here the clay becomes brilliant red and constitutes a true paint stone. Another fact to be noted in connection with the Shinarump Conglomerate is that at certain localities, and notably on Red Butte, there is at its base a clear indication of a transition to the Moencopie beds. The conglomerates proper are underlain by argillaceous shales closely resembling those of the Moencopie beds, but beneath these is a sandstone ledge which cannot be referred to the lower division, as it is more or less

cross-bedded, possesses considerable grit, and has small clay pellets included in it similar to those of the true conglomerate series, in which I have for this reason included it. This condition of things may be somewhat puzzling from the stratigraphical point of view, but the disadvantage in this respect is much more than compensated for by the evidence that it furnishes in favor of the view that all of these beds really constitute one great system, and as opposed to the view which it may be inferred that certain geologists hold, that the series of beds which I have included under the name of the Moencopie beds belongs to a different system, and are in some way connected with the underlying Paleozoic rocks. This view, in the light of the above mentioned facts is, in my opinion, quite untenable.

The Le Roux Beds.—Under the name of Le Roux beds I include the remainder of the Shinarump, deriving the name from Le Roux Wash,* which enters the Colorado Valley two miles below Holbrook, and on which some 15 miles north of Holbrook this series attains the greatest development that I have observed, probably reaching its maximum of 800 feet. These beds, too, if studied at localities where they are less developed, might be supposed to form several quite distinct subdivisions. Indeed I was of this opinion during most of my stay in the lower Little Colorado Valley, but even before leaving there the proofs of their homogeneity had become abundant.

At least the lower half consists of that remarkable formation in which I found vertebrate bones in 1899 and in which alone thus far vertebrate remains have been observed. I have sometimes designated it as the Variegated Marls, sometimes as the Belodont beds. The distinguishing features of these beds is the presence of great numbers of small buttes, the smaller ones appearing to be blue clay knolls, but the larger ones showing other colors, especially purple, and sometimes several bands of different hues. Almost everywhere at this horizon there exist plains, dotted all over with these remarkable little buttes, varying from 3 or 4 feet to 20 or 30 feet in height, usually isolated from one another and having a form peculiar to them. They are not conical in the true sense of the word, since they do not rise to a point at the summit, but are always rounded off and have the form of a well made haystack, the smaller ones looking like haycocks in a field. These butte-studded plains are of course simply the remains of a plateau or mesa which has

*The name "Leroux's Fork" was given to this wash by Lieut. Whipple's party, who followed it down some distance and encamped at its junction with the Little Colorado on Dec. 5, 1853, this being their Camp 79. See Pacific Railroad Reports, vol. iii, part i, p. 75. The name is written in two words on the Land Office map of Arizona.

been worn away, primarily by the action of water, but for a very long period there can be no doubt that wind has been the more potent agency. There is evidence throughout that entire region that the amount of precipitation was formerly much greater than at present, and in so speaking I do not refer to a very remote date geologically, but to a period which was probably post-Tertiary. Indeed, from the present condition of many of the regions where we know that the early Indians dwelt, and who must necessarily have had access to water, now perfectly dry, with all sources of water so remote that they can no longer be inhabited, it must be inferred that there has been a change in the climate within the period of human occupancy. Certain it is that water is doing very little relatively in this region now, while the agency of wind is conspicuously marked wherever it can produce effects. The peculiar form of these buttes is not such as water could have produced, while it is precisely the form that wind would naturally produce, acting upon the very fine and soft materials, somewhat resembling ashes, that compose these buttes.

Further evidence of this, if any were needed, is found in the fact that in approaching the general escarpment, which bounds these plains, the buttes tend to lose their isolated character and form ridges projecting out from the cliffs. It never happens that an entire valley or plain is covered by a single system of buttes. These systems are separated by wide intervals, often of nearly flat country, but through which it can be easily seen that water once flowed, at least in the form of temporary floods, and in such a manner as to have swept away every vestige of the former plateau, and in crossing which there are encountered one or several wide beds to which the term "wash" is popularly applied. In descending the Little Colorado this condition of things is not met with until within some 8 or 10 miles of the Lee's Ferry road. A large system of buttes is then found extending some 5 or 6 miles down the river and across the plain to the first terrace, a distance of 3 to 5 miles; then occurs the first wash, 2 miles in width, followed by another system of buttes, which is nearly due east of Tanner's Crossing, and in which most of the bones were collected by our party. There is then another wide wash, but the next system of buttes does not reach the river, but trends off in a direction nearly due north. There is still another wash before the great Moencopie Wash is reached, the direction of which is such as to be highly favorable for the preservation of these buttes, and accordingly we find their greatest development, so far as this region is concerned, along the Moencopie Wash. They do not however follow the stream up in the direction of Tuba City, but continue to trend northward along the wide valley that lies to the west of Willow Springs and Echo Cliffs.

The reason why these conditions are not earlier met with in the valley of the river is simply that the river does not follow the line of strike, and these beds, being common to the entire formation, must always occupy the same horizon. Above the point mentioned, therefore, they must be looked for farther in the interior. We found them in fact five miles east of Black Falls, or 25 miles southeast of Tanner's Crossing. The great bend in the river culminating at Winslow keeps these beds constantly so far to the northeast, and in a region where it is so difficult to penetrate, that their exact condition for a distance of over 50 miles is little known. But farther up the river, where they approach somewhat to the region of settlement, they again admit of access, and as already remarked, they appear in great force in the valley of Le Roux Wash. Here they cover an area of nearly 100 square miles and form two great amphitheatres of veritable bad lands, but in which the great variety and symmetry in the form of these buttes and ridges, as well as the variegated and iridescent colors that prevail, render them a magnificent spectacle. They can be seen from the southeast for a distance of 20 miles as a white line. Viewed from the top of the mesa out of which they have been carved, the denudation having been arrested at a particular point, they reveal more completely than at any other place the true character of this formation. In the Petrified Forest the Le Roux beds are also well developed and the variegated marls are found only half a mile east of the Lower Forest. The buttes here are quite large and well developed and bones of the *Belodont* occur in them. In the northern part of the Petrified Forest region the variegated marls lie somewhat farther to the eastward. What is called the Middle Forest lies in the midst of them, and the petrified wood, as everybody has observed, differs here considerably in its constitution and coloration from that of the upper and lower forests, which lie in the horizon of the conglomerate series.

As was remarked when treating of the conglomerates, these variegated marls are actually found stratified between the sandstones by the transformation of certain shales into marls. If these beds are carefully traced a short distance in the direction of the dip, they will be seen to thicken very rapidly and soon to take on the character of the true variegated marls. As they start from underneath a bed of sandstone which caps the conglomerates, and which does not so readily pass into marl, the buttes that are first formed are usually topped out by a block of this sandstone, and it is necessary to proceed some distance farther in the direction of the dip to reach a point where the sandstones disappear. This however ultimately takes place and the marl beds thicken to such an extent

that they have to be regarded as virtually overlying the conglomerates. In fact, in the bed of the Moencopie Wash, on both sides of which these beds are so well developed, the conglomerates can be seen distinctly passing under the marls.

So much for the variegated marls, which, for the purposes of our expedition, constituted the most important subdivision of the entire formation. But as we have seen, their maximum thickness is about 400 feet and there remain still another 400 feet before we reach the base of the painted cliffs. Throughout the whole of this fossil wood is abundant, but the character of the beds as variegated marls no longer continues. In the lower Colorado Valley, where I know it best, the variegated marls are succeeded by a sandstone ledge at least 100 feet in height, yielding black logs of very fine structure. At this point these sandstone beds constitute an escarpment and form a small terrace, the summit of which is a dip plane. Upon this lie the remains of the next set of beds, which are somewhat remarkable, primarily in being essentially limestones, but they consist mainly of loose material somewhat resembling dried mortar, for which reason I have designated them mortar beds. They are, however, very irregular in structure and contain much impure flint and large flinty stones. In the midst of them there occurs a true limestone ledge, well stratified, succeeded by a continuation of the mortar beds. In the region mentioned these beds extend to the limit of what I regard as true Shinarump, and petrified wood was found above the limestone ledge.

A wider acquaintance with this part of the formation shows that the conditions above described do not hold at all points and may even be regarded as exceptional. Nowhere else except at Black Falls did I find the lower sandstone ledge, and at most other points the limestones gradually supervene upon the variegated marls. In fact, it should be remarked, that not only the variegated marls but also the shales of the conglomerate series, which become transformed into marls, are more or less calcareous; and when we find that the entire upper portion of the Shinarump consists mainly of limestones and calcareous materials, we may regard all of this, including the variegated marls, as virtually a calcareous deposit. If we were to look abroad for its homologue in the Trias of the Old World we would find it in the Muschelkalk, while the conglomerate series might well be compared with the Buntersandstein, and the Painted Desert beds with the Keuper, to which the French term *Marnes Irisées* is only locally applicable.

In the extensive exposures on Le Roux Wash these relations are brought out with great force. Overlying the true variegated marls which stretch out for a distance of three miles across the broad eroded valley, the limestone series comes in gradually and scarcely differs except in the degree of calcareousness

from the underlying beds, but the limestone ledge is ultimately reached and is sharp and definite. It has a thickness of about 10 feet. Over it lie very heavy beds of calcareous materials beginning as mortar beds, such as I have described, but soon taking on more symmetrical forms, closely resembling the marl buttes of the valley below. The color also changes, and many of the buttes are, in whole or in part, of a deep blue or a lively purple. These constitute here the highest beds of the Shinarump and fossil wood is abundant throughout. Much the same conditions prevail in the Petrified Forest region, but the development is here much less extensive.

The Painted Desert Beds.

It remains to consider the third and highest series of the Older Mesozoic of Arizona. As already stated, these constitute the elevated cliffs that bound the valley of the Little Colorado on the northeast. Although broken through in many places, and practically wanting for long distances, they still constitute what may be regarded as a great wall separating the valley from the region of high mesas that lie in the Moqui and Navajo country. As these beds seem to contain no fossil remains, and as they are throughout the greater part of their extent practically inaccessible from the absence of water, their detailed study has been neglected, and I was able to acquaint myself with them only imperfectly and at a few points.

There is, however, no place where they are better developed than directly east of Tanner's Crossing, where we remained longest, and on several occasions the attempt was made to reach them from our camp and to examine them closely. Enough was learned to justify the positive statement that they consist almost entirely of sandstones, perfectly stratified, the different layers differing mainly in color, thickness, and fineness of structure. The great central portion constituting the escarpment and having a thickness of about 800 feet is, within these limitations, practically homogeneous. The series begins, however, with a bed of orange red sandstone, highly argillaceous, and soft in structure, easily eroded, and readily yielding to the influence of the wind. It has a thickness of about 100 feet and in the lower Colorado region stretches across the broad valley at the base of the escarpment and lies directly upon the uppermost limestones of the Shinarump. Here it forms picturesque and fantastic buttes and chimneys standing out upon the plain. It occurs in the same position overlying the Shinarump on Le Roux Wash and forming the top of the mesa which overlooks the amphitheatres that I have described. It is also seen above the Shinarump series to the east of the Petrified Forest. It is therefore probably safe to assume that this bed is continuous from Echo Cliffs to the boundary line of New Mexico.

Of the painted cliffs, considering the little that is known of them, there seems to be nothing more to say. In looking at these cliffs from a distance it is seen that they are overlain by a white formation, the nature of which it is important to consider. Before we had visited the region, so as to obtain a close view of them, it was natural to suppose that they might constitute Jurassic limestones and that the Triassic system might terminate at the line which separates them from the variegated sandstones. But upon close examination this was found not to be the case, and these white rocks were found to consist of sandstones often very pure and cross-bedded, with scarcely any admixture of marl. These without question constitute the summit of the Triassic system in this region. They are, however, not always white, or at least in some places, as for example in the vicinity of Tuba City, they are underlain by a still thicker bed of soft brown sandstone, which is somewhat argillaceous and easily worn by the wind, forming chimney buttes and ruins. This bed has a thickness along the headwaters of the Moencopie Wash of about 200 feet and is overlain at the highest points by the white sandstones to a thickness of 100 feet more. These sandstones are very porous and all the waters that fall in that region immediately pass through them, but as they approach the summit of the much harder and firmer beds that constitute the lower portions of the series these waters are arrested and come out in the form of springs, sometimes almost of small rivers, along the crest of the cliffs above the Moencopie Wash. It is on one of these springs that the little Mormon town of Tuba City is located, and this is true also of Moa Ave, Willow Springs, and other settlements in that country. Still farther back the Cretaceous lignites and limestones lie unconformably upon these uppermost sandstones of the Trias, and the Jurassic is wanting altogether.

The following columnar section of the strata of the Little Colorado Valley will make the above descriptions more clear.

DESCRIPTION OF THE SECTION. (See page 413.)

1. Argillaceous shales	Feet	100	6. Shinarump Conglomerate	Feet	800
2. Calcareous shales		100	7. Variegated marls		400
3. Argillaceous shales		200	8. Sandstones		100
4. Sandstones		100	9. Limestone ledge		20
5. Argillaceous shales		200	10. Mortar beds		80
			11. Calcareous marls		200
Total thickness of Moencopie beds		700			
			Total thickness of the Shinarump		1,600
				Feet	
			12. Orange red sandstone		100
			13. Variegated sandstones		800
			14. Brownsand stones		200
			15. White sandstones		100
			Total thickness of Painted Desert beds..		1,200
			Total thickness of Trias.....		3,500

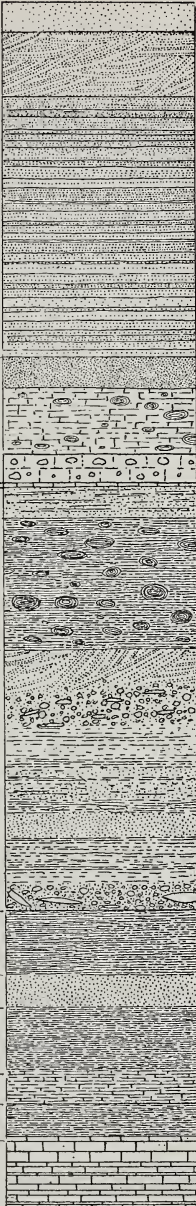
White sandstones.	15		Painted Desert beds.	Shinarump.	
Brown sandstones.	14				
Variegated sandstones, regularly stratified and brilliantly colored; the well-known Painted Cliffs.	13				
Red-orange sandstones.	12				
Calcareous marls sometimes worn into buttes.	11				
Mortar beds, flint stones.	10				
* Sandstone ledge.	9				
Sandstone ledge.	8				Le Roux beds.
Variegated marls argillaceous and calcareous with bones of beldonts, labyrinthodonts, and dinosaurs.	7				
Conglomerates and coarse cross-bedded sandstones with clay lenses interstratified with gray argillaceous shales and variegated marls.	6				Shinarump Conglomerate.
Dark chocolate-brown argillaceous shales; saliferous.	5				
Argill. sandstones, soft, dark brown.	4				
Argillaceous shales, dark brown	3				Moencopie beds.
Calcareous shales, white.	2				
Saliferous shales (=3 and 5).	1				
Unconformable limestone or sandstone.		Carboniferous (Upper Aubrey).			

* 9. Limestone ledge, definitely stratified.

ART. XLIV.—*On Pyrite and Marcasite*; by H. N. STOKES.*

WHILE pyrite and marcasite are usually readily distinguished by their crystalline form, there remains a residuum, consisting of massive or finely-grained concretionary material, in which this is not possible. The light brass color of pyrite and the tin-white of marcasite, which can be seen when the surfaces are freshly cleaned with acid and compared with standard specimens in a good white light, are not always readily made out in concretions where the surface is rough and the mineral frequently contaminated with other substances. The density too may be misleading. According to Rammelsberg and to my own determinations, pure marcasite has a density of about 4.90,† while that of pyrite is 5.00 to 5.04. The density of even well crystallized specimens of pyrite varies very considerably, and as a criterion of the presence or absence of marcasite is practically worthless, especially in massive or concretionary material. A series of crystallized pyrites, which were shown by the method to be described below to be free from marcasite, gave densities varying from 5.04 to 4.82, while a pyrite concretion, also free from marcasite, gave only 4.56. A. A. Julien‡ has employed the density to determine the relative amount of pyrite and marcasite in mixtures, and on this method he has based the hypothesis that most specimens of these minerals, even when well crystallized, are intimate mixtures of the two, passing into complete paramorphs. It will be shown below that this view is untenable.

The greater rapidity of oxidation is sometimes used to distinguish the minerals. While it is unquestionably true, that under precisely similar conditions marcasite vitriolizes more rapidly than pyrite, conclusions based on this fact have usually failed to take into account the important factor of the ratio of surface to mass; a compact, brilliant, marcasite is stable while a porous mass of pyrite vitriolizes readily. Only when we know this factor can we draw any conclusion from the fact of rapid vitriolization.

Penfield has described a method for distinguishing the minerals, based on the fact that boiling nitric acid liberates sulphur from marcasite but not from pyrite, a method which is clearly not adapted to detecting pyrite in the presence of marcasite.

* This paper is a condensation of Bulletin No. 186 of the United States Geological Survey and is published by permission of the Director.

† The density 4.80 given by Julien (*Annals N. Y. Acad. Sci.*, vol. iv, 1887, pp. 177, 210) is certainly too low.

‡ *l. c.* pp. 166, 213.

There is no method hitherto known by which even a qualitative determination of the two is possible in mixtures.

In connection with the study of the action of ferric salts on sulphides, I was struck by the quantitative difference of the behavior of pyrite and marcasite, and out of this has been developed the following method for distinguishing them and for determining them quantitatively in mixtures.

That ferric salts oxidize the sulphur of pyrite to sulphuric acid was observed by de Koninck* and the same has since been noted by other observers, without an attempt having been made to follow the reaction quantitatively. The study which I have made of this reaction shows that under uniform and easily controllable conditions the percentage of the total sulphur oxidized is very constant for each mineral, but differs greatly in the two, and in mixtures is an index of the amount of each constituent present. To avoid tedious gravimetric determinations I employ a standard solution of ferric ammonium alum containing 1 gram Fe''' per liter, with 4 grams free sulphuric acid to prevent the formation of basic salts. An excess of the carefully prepared mineral is boiled with this solution under absolute exclusion of air until the reduction of the ferric salt is practically complete. The reaction may be regarded as taking place in two stages:

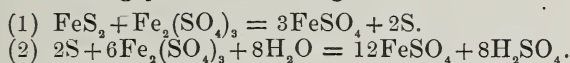

Since the active mass of the solid phase is constant, it matters not how much mineral be taken for a given volume of the solution provided it be in excess, nor is it necessary to know the absolute quantities of iron and sulphur involved in these reactions, or the strength of the permanganate solution. It suffices, in deducing an expression for the oxidized sulphur, to employ symbols expressing the permanganate equivalent of the iron, and the symbols used represent simply the volumes of permanganate consumed by a given volume of the solution.

For a given volume let

$$\begin{aligned} a &= \text{iron in the original solution,} \\ b &= \text{resulting ferrous iron,} \\ c &= \text{resulting total iron.} \end{aligned}$$

Then

$c - a =$ increment of iron resulting from decomposition of FeS_2 ,
and

$$2\left(\frac{31.83}{55.60}\right)(c-a) = \text{total sulphur in decomposed sulphide.} \quad (\text{A})$$

* *Annals Soc. Geol. Belgique*, vol. x, 1883, p. 101; *Zeitschr. anorg. Chem.*, vol. xxvi, 1901, p. 123.

Also,

$$3(c-a) = \text{ferrous iron produced according to equation (1)}$$

and

$$b-3(c-a) = \text{ferrous iron produced by oxidation of sulphur.}$$

According to equation (2), 1 atom of sulphur requires for oxidation 6 atoms of ferric iron, producing 6 atoms of ferrous iron: hence,

$$\frac{1}{6} \cdot \frac{31.83}{55.60} (b-3(c-a)) = \text{sulphur oxidized. (B)}$$

Calling the percentage of sulphur oxidized p , we obtain from (A) and (B)

$$p = \frac{\frac{100}{6} \cdot \frac{31.83}{55.60} (b-3(c-a))}{2 \left(\frac{31.83}{55.60} \right) (c-a)} = \frac{8.333b}{c-a} - 25.$$

It thus appears that three titrations suffice to determine the percentage of sulphur oxidized, and that neither the amount of FeS_2 , the volume of the ferric solution used, nor the absolute titer of the latter or of the permanganate need be known. As, however, the proportion of sulphur oxidized varies with the strength of the ferric solution, the extent of reduction, and the temperature, it is necessary, in order to obtain comparable results, to use a solution of standard composition and a standard temperature, and to continue the action to complete reduction.

The value p , or the percentage of sulphur oxidized, may be called the *oxidation coefficient*. The oxidation coefficient of pyrite, as established by the study of various specimens, varies between 60 and 61 with a mean of 60.4, while that of marcasite varies between 16.5 and 18. In duplicate determinations, properly made, it may differ about one-half unit. It is clear then that in these figures we have perfectly characteristic constants of the two minerals. It may be noted that the figures are independent of any contaminations which do not affect the titer of the solution, or which can be removed by previous treatment.

The explanation of the oxidation coefficient and its difference in the two cases is probably the following: the molecules of FeS_2 are acted on by a reagent which is capable of oxidizing the iron more rapidly than the sulphur. The rate of solution of the pyrite is greater than the oxidation rate of the sulphur, hence a portion of the latter, under the given conditions about 40 per cent, escapes and when once in the free state, as I have found, is scarcely attacked; at the same time the limit of the

oxidation rate of the iron is not reached. Marcasite dissolves much more rapidly, the result being that a still greater portion of the sulphur, about 82 per cent, escapes. The same explanation naturally applies to their different behavior towards nitric acid as observed by Penfield. It is not an indication of the different *chemical* constitution, but of a different solution tension conditioned by different crystalline structure. Doubtless a similar method can be applied in other cases of dimorphism to determining which form is more soluble. I propose to apply the method to distinguishing other dimorphic compounds.

For the details of the operation and apparatus I must refer to the extended article, stating here that the material must be absolutely free from oxidation products, and must therefore be extracted with acid and washed and dried in carbon dioxide, and that air must be rigidly excluded during the operation and complete condensation of the steam provided for. The standard solution oxidizes both pyrite and marcasite much more slowly at 20°, but the per cent of sulphur oxidized is greater, namely about 81 per cent for pyrite and 31 per cent for marcasite.

Doubtless the action of ferric salts plays an important part in nature in the disintegration of pyrite and marcasite, the iron acting as a transferer of oxygen. The conditions under which the sulphur undergoes complete oxidation are as yet not clear, and this subject is now under investigation.

Mixtures of pyrite and marcasite.—It is clear that the oxidation coefficient of any given mixture of pyrite and marcasite cannot be deduced by any simple process from the coefficients of the pure minerals. Each mineral is here decomposing in a solution containing the reaction products of the other, and only an extensive knowledge of the influence of concentration, acidity and dissociation would enable us to deduce theoretically a curve for such mixtures. It has therefore been necessary to construct the curve from data obtained by experiments on artificial mixtures. Since the action is a surface action, the result depends, not on the relative weights, but on the relative surfaces, and uniformity in this respect was obtained by always grinding weighed portions of the minerals together. The results, with different preparations and different samples, show that perfect agreement can be obtained in this way, the results for different samples of a given composition not differing more than one-half unit. The following table gives the mean results obtained:

Per cent pyrite,	0	5	10	20	40	60	80	90	95	100
Value of p ,	18.0	16.0	15.2	17.1	22.3	29.0	40.3	48.9	52.9	60.5

With these data, a curve is drawn on cross section-paper from which it is possible, after finding the oxidation coefficient of the mixture, to read off the relative proportions of pyrite and marcasite to within 1 per cent when the mixture is quite rich in pyrite and to 2 or 3 per cent when it consists mainly of marcasite. The existence of a well marked minimum in mixtures with 10 per cent pyrite is noteworthy. I have detected similar minima and maxima in curves given by mixtures of pyrite with other minerals. The uncertainty of duplicate values for mixtures with less than 25 per cent pyrite, caused by this minimum, is obviated by mixing the specimen with a known quantity of pyrite and determining the oxidation coefficient of the new mixture. If x represents the percentage of pyrite in the original sample, a mixture of 90 parts of this with 10 parts pyrite will give

$$0.9x + 10 = \text{per cent pyrite in new mixture,}$$

whence x , composition of the original material, is easily deduced. Here, as before, the results express simply the percentage composition of the iron disulphide, indifferent substances being without effect.

In regard to the influence of impurities, it may be stated that substances which do not contribute iron to, or effect reduction of, the ferric salt are without influence. Pyrrhotite, limonite, siderite, and other soluble iron compounds and zincblende or galena in small amounts may be extracted by heating with dilute hydrochloric acid; nickel and cobalt and other iron free sulphides not extractable by acid give abnormal results. For details as to the behavior of impurities reference must be made to U. S. Geological Survey Bulletin No. 186. In this connection, it is interesting to note that in a pyrite carrying 3 per cent copper it is possible to ascertain whether the copper be present as chalcopyrite, or as chalcocite or bornite, a determination which could scarcely be made by the usual analytical methods. The values of p^* for a 3 per cent mixture were found to be:

Pyrite-chalcopyrite	62.7
Pyrite-chalcocite	75.9
Pyrite-bornite	76.4

The difference is many times the probable error of a determination.

Small amounts of chalcopyrite mixed with pyrite or marcasite may be readily detected by exposing the sample to bromine

* p is here obtained as before by substituting the permanganate values in the above equation, but in this case it does not represent strictly the percentage of sulphur oxidized.

vapor for half a minute and then to hydrogen sulphide gas; the chalcopyrite is blackened, while the iron sulphide remains bright. I have used the same method to detect and establish the nature of minute grains of chalcopyrite inclosed in rocks.

My examination of various samples of doubtful nature, especially of concretions, shows that the finely fibrous specimens passing as marcasite are very commonly pyrite.

Dr. Julien has very kindly given me a number of the identical specimens of supposed marcasitic pyrite and paramorphs of marcasite after pyrite which were described in his paper.* I have found that those which show regular crystallization are actually pyrite free from marcasite, notwithstanding their density would lead to the conclusion that they were either pure marcasite or a mixture. So far as my results go, there is no evidence for the existence of such mixtures or that the supposed paramorphs sometimes described are anything more than replacement or incrustation pseudomorphs. I have, however, found a few specimens of marcasite which enclose pyrite which cannot be detected by a lens, and which was probably simultaneously deposited.

A. P. Brown's hypothesis.—A. P. Brown† has published experiments which consisted in heating pyrite and marcasite in sealed tubes at 200° with cupric sulphate solution, according to which marcasite gives up its iron wholly in the ferrous form, while pyrite gives a mixture containing one-fifth ferrous and four-fifths ferric iron. From this he concluded that the iron in marcasite is wholly ferrous, while in pyrite it is four-fifths ferric. I have conducted a series of similar experiments with pyrite and marcasite and cupric sulphate, under the same conditions, in which the greatest care was taken to eliminate oxidation and to determine both ferrous and ferric iron in the solution and the precipitate. My results all agree in indicating that the pyrite is more slowly attacked than marcasite, but that the iron is found as ferrous iron only in the solution, and in the precipitate as ferric iron mixed with cuprous oxide and cuprous sulphide. The results are

For pyrite	{ 62.5—	69.9 per cent ferrous iron
	{ 34.8—	30.1 per cent ferric iron.
For marcasite	{ 58.2—	66.6 per cent ferrous iron
	{ 41.8—	33.4 per cent ferric iron.

It appears therefore, that there is no essential difference between the decomposition products of pyrite and marcasite, while Brown's view requires 20 per cent ferrous iron for

* Annals N. Y. Acad. Sci., vol. iv, 1887, pp. 176, 204.

† Proc. Am. Philos. Soc., vol. xxxiii, 1894, p. 225; Chem. News, vol. lxxi, 1895, p. 179.

pyrite and 100 per cent for marcasite. The relative amounts of ferrous and ferric salts depend simply upon the establishment of equilibrium between the solution and the decomposition products of the pyrite and marcasite, not upon any fundamental difference in the minerals themselves, and the hypothesis in question, while possibly true, is thus far devoid of a valid experimental basis.

As part of an investigation of the reactions involved in the secondary deposition of copper by sulphides, it may be mentioned that cupric chloride at 200° decomposes pyrite according to the equation



Sulphuric acid is also formed by the action of cupric chloride on cupric sulphide and apparently from pyrite and cupric sulphate, so that the oxidation of sulphur appears to be a necessary part of the reaction when certain sulphides are acted on by cupric salts. These reactions, with other salts and sulphides, are still under investigation.

ART. XLV.—*Studies of Eocene Mammalia in the Marsh Collection, Peabody Museum*; by J. L. WORTMAN. With Plates VIII and IX.

[Continued from p. 382.]

The Manus. (Figures 48, 49.)—As compared with the pes, the bones of the manus, especially the metacarpals and phalanges, appear shorter, heavier, and more robust. The carpus contains the eight bones common to the Creodonts. The scaphoid is rather flattened from above downwards; its proximal surface is occupied by an anterior convex facet for contact with the radius, posterior to which there is a roughened area for ligamentous attachment, and a large posteriorly projecting process at the inner posterior angle. Externally there is a

49

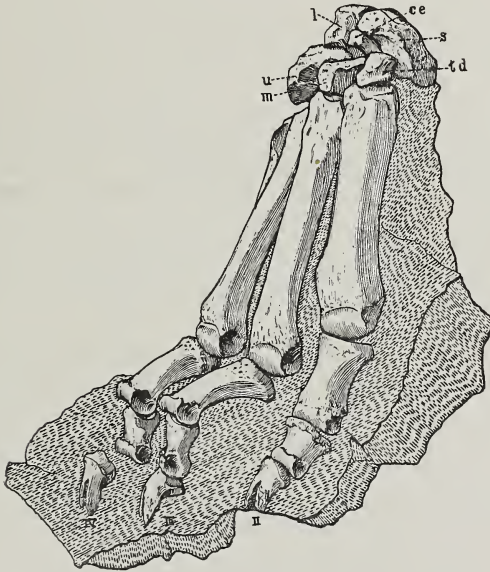

FIGURE 49.—Same foot as in Figure 48, before removal of matrix; side view; one-half natural size.

facet by which it touches the lunar, and inferiorly there are three facets,—an inner lunate, a median rhomboidal, and an outer elongated oval, for articulation with the trapezium, trapezoid, and centrale, respectively.

The lunar is distinct, and of a more or less quadrate form when viewed from in front; superiorly it presents a convex facet for articulation with the radius; internally a flattened

area by which it is closely applied to the scaphoid and centrale; externally a similar area for contact with the cuneiform, and distally a deeply saddle-shaped articular surface, divided by a median antero-posterior ridge into two equal parts, for contact with the unciform and magnum.

The cuneiform is flattened from above downwards and is imperfectly quadrilateral in form, with the postero-external angle much produced, when viewed from above; its anterior and external surfaces are very rugose, presumably for the attachment of ligaments. Superiorly there is a cup-shaped articular depression for contact with the ulna, while behind this is a postero-external facet by which it touches the pisiform. Inferiorly there is an excavated articular surface by means of which it rests on the unciform.

The pisiform, like the other bones, has an unusually rugose surface; it has the usual form and articulation common to the Carnivora, and does not deserve any more extended description.

The unciform is by far the largest bone of the carpus; it rests almost equally upon the fourth and fifth metacarpals, abutting upon the side against the third metacarpal and the magnum, and supports the lunar and cuneiform.

The magnum is relatively small, and is remarkable for its great antero-posterior length as well as the low position of the head,—a form quite unknown elsewhere among the Carnivora. Its articulations are as follows: It rests exclusively upon the third metacarpal; laterally it develops a contact with the head of the second metacarpal and the trapezoid; externally it touches the unciform, and superiorly it supports about equally the lunar and centrale.

The trapezoid is also small in comparison with the other bones of the carpus; it rests upon the second metacarpal, touches the magnum upon its external surface, the centrale and scaphoid above, and upon its internal face exhibits a distinct facet for the trapezium.

The trapezium is a stout ossicle, somewhat larger than in the dog, which articulates with the scaphoid above and the trapezoid and second metacarpal externally. It has an irregular triangular shape, and at its distal extremity bears an oval convex facet for articulation with the metacarpal of the pollex.

The last bone of the carpus which remains to be described is the centrale. This is a small antero-posteriorly elongated ossicle which lies at the junction of the scaphoid and lunar, mainly under the former, and resting about equally upon the trapezoid and magnum. When seen from in front, the bone appears to lie almost exclusively upon the magnum; posteriorly, however, it passes over on the trapezoid to a considerable extent.

The arrangement of the metacarpals, like those of the dog, is on the paraxonic plan; the third projects a trifle beyond the fourth, but the difference is so slight as not to affect materially this order. In like manner, the distal ends of the second and fifth reach about the same level. The actual length of the third is greater than the fourth, in the same way that the second is longer than the fifth, but these differences are counterbalanced by the overlapping of their proximal articular extremities. The overlapping and consequent interlocking of the second with the third, and the third with the fourth, are almost as great as in the metacarpals of the felines and dogs, but the fifth articulates with the fourth by means of a nearly plane, flat face, with little or no interlocking. In size, the second metacarpal is much the largest, having a more or less flattened shaft. The third and fourth have about an equal degree of stoutness, the shaft of the third being a trifle the thicker of the two. The sides of these two bones are considerably flattened laterally, especially in the proximal half of their extent, where they are more closely approximated, but the amount of this compression is much less than in the dog. The fifth is the shortest bone of the four. In the matter of the stoutness of the shaft, however, it is intermediate between the second and third. The distal extremities resemble those of the dog, having well-developed keels confined to the palmar surface. The metacarpal of the pollex is missing and there is no certain means of determining the degree of reduction which it had reached, unless we judge by the size of its articulation with the trapezium. This would seem to indicate that it was small and more or less vestigial, so that the fore foot was essentially tetradactyle.

The phalanges of the proximal row are shorter, broader, and heavier than those of the hind foot. That of the second digit is notably shorter and stouter than the others. The fourth is the most slender, after which follow the third and second. The phalanges of the second row are relatively short and heavy, and exhibit a considerable degree of distal asymmetry. The unguals are rather short and depressed; they are deeply fissured at their extremities and the subungual processes are of moderate size. The unguual foramen is present in all, and is of good size.

Hind Limb.—The pelvis, figure 50, is much damaged and many parts are missing, but enough remains to furnish some of the more important points of its structure. Of the ilium, the region of the sacro-iliac synchondrosis is present with that of the acetabulum. A considerable portion of the ischium, together with important parts of the pubis, sufficient to give a clear idea of the pelvic outlet, are also preserved. From these

fragments it can be determined that the ilium was of good length and considerably expanded anteriorly, as in *Mesonyx*. The tubercle for the tendon of the *rectus* is large and rugose. The acetabulum is large, of moderate depth, and the acetabular notch is deeply incised. The ischial spine is distinct, the obturator foramen long and narrow, and the pubis comparatively short. This latter fact, taken in connection with the narrowness of the sacrum, figure 51, gives a remarkably small outlet to the pelvis. There is, of course, no means of deter-

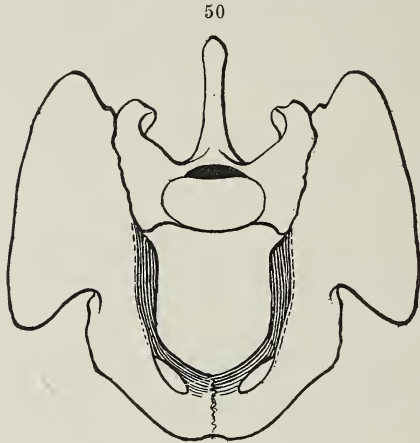
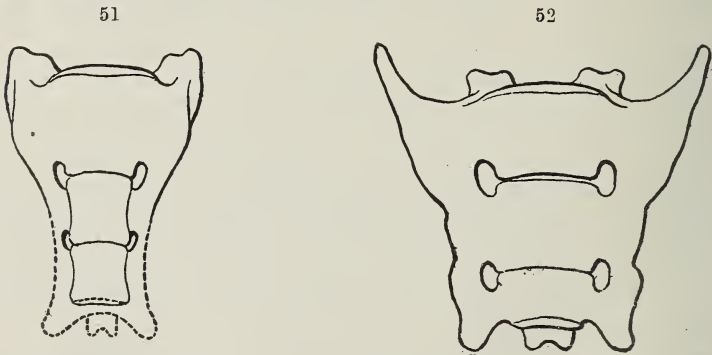

FIGURE 50.—Pelvic outlet of *Dromocyon vorax* Marsh; anterior view; showing dimensions; one-half natural size.



FIGURES 51, 52.—Sacrum of *Dromocyon vorax* Marsh, and of a Newfoundland dog; under view; showing difference in width; one-half natural size.

mining the sex of the fossil; but assuming it to be a male, if the pelvic outlet in the female were as small in proportion, the young must have been very small at birth. For the sake of comparison, I give in figure 53 an outline drawing of the

pelvic outlet of a male Newfoundland dog, and in figure 52 an under view of the sacrum. The bones of this skeleton are but little larger than those of *Dromocyon*. The difference is certainly very great; this is all the more remarkable, when we remember that the skull of *Dromocyon* is proportionally much larger than that in the dog. If, as before remarked, the females had a proportionally small pelvic outlet, there seems to be no escape from the conclusion that the young were born in a very weak and helpless condition, like the Marsupials, a fact which may have had something to do with their extinction, especially when it is remembered that they were exposed

53

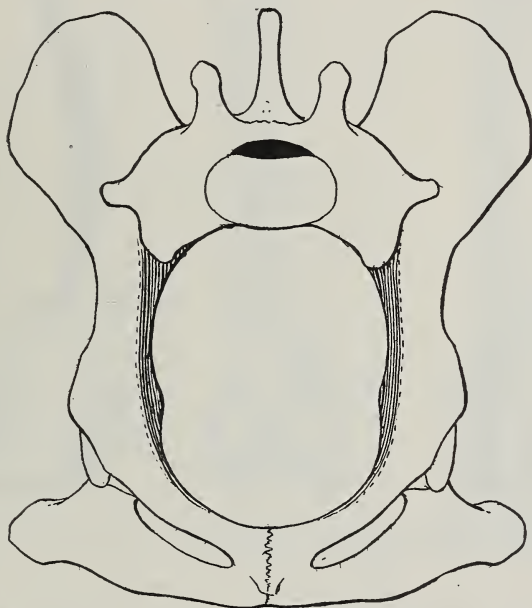

FIGURE 53.—Pelvic outlet of male Newfoundland dog; anterior view; showing dimensions; one-half natural size.

to competition with the rapidly developing contemporary Canids.

The Femur. (Figures 54, 55, 56, 57, 58.)—In all of its essential features, the femur presents a very striking likeness to that of the dog; it is, however, proportionally a little shorter and the shaft has a greater backward curvature. The head is relatively larger, the neck shorter, and the *trochanter major* of greater fore and aft extent. There is a large second trochanter which is placed upon the internal margin of the shaft, and an elongated third trochanter which extends well down upon the outer border. The distal end of the bone is



FIGURES 54, 55, 56.—Femur of *Dromocyon vorax* Marsh; anterior, posterior and side views; one-half natural size. (Type.)



FIGURE 57.—Distal end of femur of *Dromocyon vorax* Marsh; one-half natural size. (Type.)

FIGURE 58.—Head of femur of *Dromocyon vorax* Marsh; end view; one-half natural size. (Type.)

remarkable for the great antero-posterior diameter of the condyles, exceeding the dog in this respect, and quite equaling some of the Artiodactyle Ungulates. There is a distinct popliteal fossa, the inner edge of which is prominent and marked at its lower extremity by an oval facet, for a rather large popliteal fabella. The prominence of this part of the bone indicates unusual strength for the tendinous origin for the outer and inner heads of the *gastrocnemius*, which is well in accord with the cursorial powers of the species. The condyles are subequal in size and the inner projects to a slightly lower level than the outer. There is a deep intercondylar notch leading forward into a well-marked rotular groove.

The patella is relatively larger than that of the dog; it is elongated, narrow from side to side, and rather thick from before backwards. The proximal extremity is truncated and roughened for the attachment of the large quadriceps tendon. It has the typical form of a running animal.

The Tibia and Fibula. (Figures 59, 60).—The tibia, as in the dog, is a trifle shorter than the femur. The head displays two subequal depressions, of which the outer is slightly the larger, to receive the femoral condyles. The spine is bifid, but the separation is not so clearly evident as it is in the dog. The cnemial crest is very large and extends more than half-way down the shaft, whereas in the dog it is limited to the upper third. The upper posterior portion of the shaft is deeply excavated. The inferior extremity exhibits a trochlear surface similar to that of the dog. The internal malleolus is a strong process and the trochlear grooves are pronounced.

The fibula has a relatively stouter shaft than that of the dog, but at the same time is much reduced; it is applied to the lower end of the tibia for a considerable distance. The shaft is triangular above and oval in cross-section below. The distal end is large, and forms a stout external malleolus in the ankle joint; it articulates with the astragalus by means of a lateral facet, and does not touch the calcaneum.



FIGURE 59. — Tibia and fibula of *Dromocyon vorax* Marsh; anterior view; one-half natural size. (Type.)

The Pes. (Plate VIII.)—As a whole, the pes is very dog-like in general appearance; the loss of the hallux, the compressed, elongated, and highly interlocking character of the metatarsals, as well as the distinctive “square-cut” aspect of their distal ends, recalls at once the hind foot of the dog. There are, however, some important differences which will be pointed out in the course of this description. The astragalus, if found dissociated from the other parts of the skeleton, and

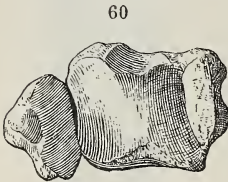

FIGURE 60.—Tibia and fibula of *Dromocyon vorax* Marsh; end view; three-fourths natural size. (Type.)

if the head were not so convex from before backwards, might readily be mistaken for that of a Perissodactyle Ungulate. Indeed, it furnishes just such a transitional stage as we may readily believe to have preceded the peculiarly specialized type of this bone in the Artiodactyla. The trochlear surface is deeply grooved, the head is set rather obliquely upon the body by a moderately elongated neck, and its distal end is divided into two unequal facets. Of these the larger is internal, slightly concave from side to side, and articulates with the navicular; while the outer is narrow, much prolonged upon the posterior surface, and articulates with the cuboid. The calcaneal facet is narrow and deeply concave from above downwards, while the sustentacular facet is broad, slightly convex, and more or less pyriform in outline. There is no astragalar foramen. As compared with the astragalus of the dog, the transverse axis of the head coincides more nearly with the transverse plane of the trochlea; the calcaneal facet is narrower, and the sustentacular facet is broader.

The calcaneum has a relatively longer tuber than that of the dog, but otherwise the two agree very closely. The cuboid is proportionally larger than that of the dog. Proximally there is a distinct facet for the astragalus, but otherwise the articular surfaces are much alike in the two. In the posterior aspect, however, they differ considerably; in the dog the cuboid has a double peroneal tubercle, of which the smaller is external and just above the commencement of the peroneal groove, and the other, larger, is located near the center of the posterior surface. The direction of the peroneal groove, which is large, is downwards and inwards. In *Dromocyon* there is but a single large elongate tubercle, occupying nearly the whole of the posterior surface. Beneath the distal extremity of this tubercle is a notch, which is converted into a distinct groove upon the outer surface of the bone, marking the course of the long peroneal tendon. In the dog the tendon passes obliquely

down to its attachment upon the base of the second metatarsal, and the groove is relatively large; whereas in *Dromocyon* it is small, and the tendon passed down to the outer edge of the tubercle, thence turned abruptly inwards to be inserted in the same place. The relatively large size of the peroneal tubercle, which serves principally for the attachment of the calcaneo-cuboid ligament, may be taken to indicate unusual firmness of the tarsal joint.

The navicular has much the same general shape as in the dog, and differs from it in that it is narrower, and its proximal surface more deeply saddle-shaped; it articulates with the cuboid in quite the same way, and distally exhibits the three usual facets for the cuneiformia. Posteriorly it presents some important differences from that of the dog. In the case of the latter, there are two more or less distinct navicular tubercles, separated by a wide sulcus. In *Dromocyon* there is a single tubercle, which is produced into a long pointed process. The three cuneiformia differ from those of the dog, in that they are decidedly higher and narrower from side to side; their manner of articulation is, however, much the same. The internal cuneiform is large and elongate, bearing upon its distal extremity an articular facet for a rudiment of the first metatarsal.

The metatarsals closely resemble those of the dog, not only in their elongate, compressed, and highly interlocking character, but they show a decided tendency towards lateral flattening of their contiguous surfaces. Their distal ends, moreover, exhibit that characteristic "square-cut" appearance so common to the modern Canidæ. The foot is of the strictly paraxonic type, the third and fourth metapodials being of equal length. While the second and fifth are also of equal length, the second is much the larger and stouter bone, the disparity in size being considerably greater than that seen in the dog, and about equal to that of the fore foot. The distal metapodial keels are present and well developed; they are, however, confined to the plantar surface and do not extend more than half-way around upon the dorsal surface.

The proximal phalanges are proportionately shorter, stouter, and more robust than in the dog, but the articular faces have very much the same disposition and extent. Proximally the plantar notch is not so deeply incised as in the phalanges of the dog, but their dorso-plantar curvature appears to be somewhat greater. The median phalanges, or those of the middle row, are proportionately still shorter than those of the first, as compared with the dog. They exhibit a slight degree of distal asymmetry. The unguals are short, rather broad, and deeply fissured.

The following principal measurements are herewith given :

Length of skull	318·5 ^{mm}
Width of skull at posterior portion of zygomata	160·
Height of anterior nares	54·
Vertical diameter of orbit	43·
Height of occiput above base of condyles	113·5
Width of condyles	54·
Greatest width of occiput	32·
Length of superior tooth line from anterior border of incisors	154·
Length of premolar series	62·
Length of molar series	45·
Antero-posterior diameter of superior canine	20·
Length of lower jaw	248·
Length of inferior dentition	151·
Greatest depth of jaw including coronoid	93·
Depth of jaw opposite first molar	43·
Width of palate between canines	33·5
Width of palate opposite first molar	46·
Transverse diameter between inferior canines (internal)	18·
Transverse diameter between inferior canines (external)	44·
Transverse diameter of inferior canine	13·
Total length of vertebral column, as articulated, including sacrum, exclusive of curves; tail not included	860·
Total length of vertebral column, including curves; tail not included	910·
Length of tail (estimated)	970·
Length of cervicals	230·
Length of dorsals	338·
Length of lumbars	280·
Length of sacrals (estimated)	62·
Length of body of axis, including odontoid	60·
Height of axis at posterior border of centrum	63·
Antero-posterior length of spine of axis	68·
Height of seventh cervical, including spine	113·
Height of first dorsal, including spine	128·
Height of ninth dorsal	64·
Length of body of penultimate lumbar	36·
Width of sacrum	40·
Length of first rib	71·
Length of third rib	132·
Length of seventh rib	169·
Width of third rib	20·
Width of seventh rib	13·
Length of scapula	197·
Antero-posterior diameter of glenoid cavity	38·5

Transverse diameter of glenoid cavity	27 ^{mm}
Length of humerus	210
Transverse diameter of distal end of humerus	35
Antero-posterior diameter of distal end of humerus	36
Length of ulna	230
Length of olecranon of ulna	49.5
Length of radius	174
Transverse diameter of head of radius	26
Antero-posterior diameter of head of radius	17.5
Transverse diameter of distal end of radius	36.5
Antero-posterior diameter of distal end of radius	22
Length of fore foot	152
Width of carpus	40
Length of second metacarpal	65
Length of third metacarpal	75.5
Length of fourth metacarpal	71
Length of fifth metacarpal	56
Length of first phalanx, digit II	28.5
Length of second phalanx, digit II	15
Length of ungual phalanx, digit II	15
Length of first phalanx, digit III	28.5
Length of second phalanx, digit III	15
Length of ungual phalanx, digit III	16
Length of first phalanx, digit V	27
Length of second phalanx, digit V	13.5
Length of ungual phalanx, digit V	15
Length of pelvis (estimated)	240
Depth of pelvis at anterior border of pubic symphysis	64
Vertical diameter of pelvic outlet	58
Transverse diameter of pelvic outlet	42
Antero-posterior diameter of acetabulum	30.5
Length of femur	227
Transverse diameter of proximal end of femur	51
Transverse diameter of distal end of femur	42
Antero-posterior diameter of distal end of femur	49
Length of tibia	217
Transverse diameter of head of tibia	44
Antero-posterior diameter of head of tibia, including cnemial crest	54
Transverse diameter of distal end of tibia and fibula	39
Antero-posterior diameter of distal end of tibia	23
Length of hind foot	235
Length of tarsus, including the <i>tuber calcis</i>	91
Width of tarsus	32.5
Length of calcaneum	66
Length of astragalus	49
Width of astragalus	32
Length of cuboid in front	25

Length of second metatarsal.....	78.5 ^{mm}
Length of third metatarsal.....	87.
Length of fourth metatarsal.....	87.
Length of fifth metatarsal.....	74.5
Length of first phalanx, digit II.....	27.
Length of first phalanx, digit III.....	29.
Length of first phalanx, digit IV.....	29.5
Length of first phalanx, digit V.....	26.
Length of second phalanx, digit III.....	16.
Length of ungual phalanx, digit III.....	15.5

This specimen is from the volcanic-ash bed of Henry's Fork, Bridger Basin, and was found by J. Heisey.

[To be continued.]

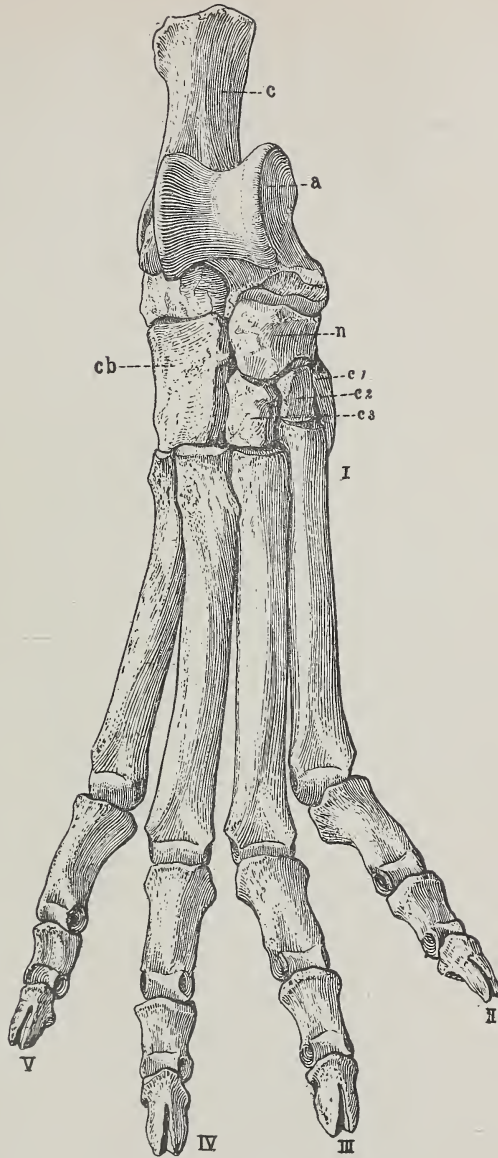

EXPLANATION OF PLATE VIII.

Right hind foot of *Dromocyon vorax* Marsh; anterior view; three-fourths natural size. (Type.)

c, calcaneum; *a*, astragalus; *n*, navicular; *c1*, *c2*, *c3*, internal, middle, and external cuneiformia; *cb*, cuboid.



EXPLANATION OF PLATE IX.

Mounted skeleton of *Dromocyn verax* Marsh; side view; one-twelfth natural size. (Type.)

ART. XLVI.—*Dielectric Constant of Paraffins*; by WILL G. HORMELL.

THE following paper presents some experiments in which by means of a modified form of the Blondlot oscillator the dielectric constants of four commercially different paraffins were obtained for 40, 60, and 80 centimeter waves. The paper also contains an investigation of the relative velocities of 80 centimeter waves along magnetic and non-magnetic wires of different diameters. And finally there is given in the table, by way of comparison, the light index of refraction of the different paraffins for the D_1 line as obtained by means of the Abbe refractometer.

Apparatus.

Figure 1 is a diagram of the connections made to the various pieces of apparatus used in the experiment. The terminals

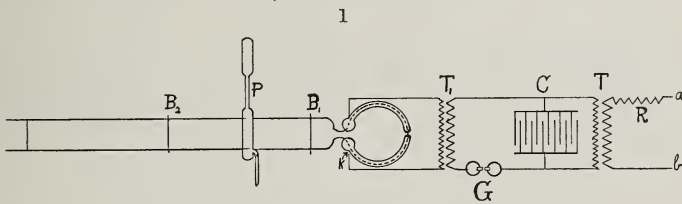

a and b are connected to a commercial line delivering an alternating current with a pressure of 52 volts. The resistance R is used to regulate the quantity of current flowing through the circuit. T is a transformer whose primary of about 200 turns is wound around a core of soft iron wire. The secondary of the coil contains about 2000 turns. C is a battery of four Leyden jars each having a capacity of 5900 electrostatic units. T_1 is a Tesla coil made after the formula given by Tesla and is capable, when fed to its full capacity, of giving a ten-inch spark. In all the following experiments a current of about 7 amperes was taken from the commercial line which would give in the Tesla coil a spark of not more than 3^{cm}. G is a spark gap consisting of two small iridium* cylinders inserted in $\frac{3}{4}$ -in. brass spheres. The length of the spark gap can be nicely adjusted by means of a screw thread on the axle of one of the spheres.

The constancy of the spark at this gap is of the greatest

* G. W. Pierce, this Journal, vol. ix, p. 256, 1900.

importance in securing the best possible results from the oscillator. A rapidly rotating disc presenting projections to the opposite terminal of the gap gave very indifferent results. Zinc balls, polished brass balls, and brass balls with platinum terminals inserted after the fashion of the iridium cylinders, were used, but none of these gave the constancy secured through the use of the iridium. Platinum terminals gave the next best results, but on account of their rapid deterioration they required almost constant attention in order to keep their surfaces well polished. The iridium gap needs no attention except for occasional adjustment of length.

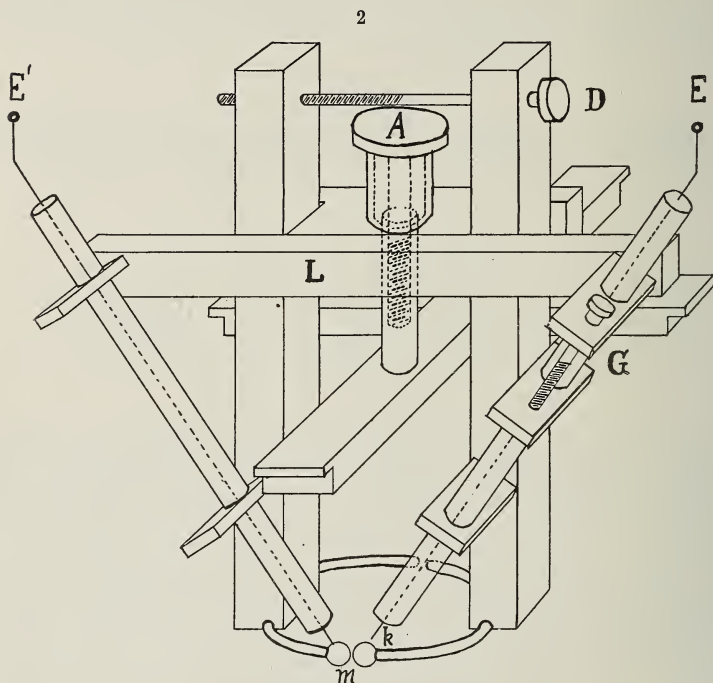

The secondary terminals of the Tesla coil are joined to the primary terminals $E'E$ (figure 2) of the Blondlot oscillator. The remaining portion of figure 1 is shown in detail in figure 3.

The Blondlot oscillator (figure 2) is the modified form used by W. D. Coolidge.* Some additions, however, have been made in order to bring the adjustments more completely under

* *Annalen der Physik*, lxvii, p. 578, 1899.

the control of the observer. The two semicircles comprising the primary coil are firmly fastened to two hard rubber uprights which are pivoted on the crossbar L.

The screw D regulates the spark gap m . A spiral spring, not shown in the figure, wound round D, keeps the two uprights separated. The wire E' is passed through a thick-walled glass tube and is inserted in one of the ball terminals of the primary. The other wire E forms a spark gap at k , which is regulated by the screw G. The glass tubes are held in place by pressure screws not shown in the figure. This framework holding the primary is placed in a 4×5 in. glass jar. Immediately under the primary a secondary of the same

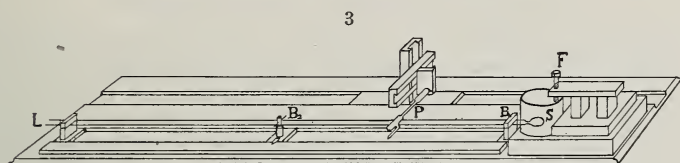

diameter is placed, and its terminals are led out through two corks inserted in the side of the jar (figure 3). This coil is firmly held in position by three rubber posts sent up from a rubber plate placed in the bottom of the jar. A mica plate is placed between the primary and secondary, the distance between which is regulated by the screw A (figure 2). The screw-clamp F (figure 3) holds the framework of the primary rigidly in place. When the coils are in use the jar is filled with kerosene.

The first bridge, B_1 (figure 3), rests in a groove in the rubber support. It is 30^{mm} long, 1^{mm} thick and 3^{mm} wide. It has two holes in which to receive the ends of the secondary, and these when in place are soldered to the bridge. Two grooves symmetrically placed are filed on top of the bridge, 1.8^{cm} apart. The Lecher wires, L, rest in these grooves and are clamped firmly to the bridge by means of the top of the rubber support, which is furnished with two strong brass screws. The other ends of the Lecher wires, 1.8^{cm} apart, are clamped in a second rubber support. The supports, about 150^{cm} apart, are strong enough to allow a tension of several pounds on the wires. Unless otherwise designated, the Lecher wires are made of No. 18 copper wire.

The second and movable bridge, B_2 , is a brass wire 1^{mm} in diameter and 4^{cm} long. The post holding the bridge works in a socket containing a spring which presses the bridge against the two wires. The base of the bridge holder has an index

extending over a meter rod, thus indicating the position of the bridge.

P is a Plücker argon tube mounted in such a way that it may be moved at will along the three mutually perpendicular directions. Tubes filled with other gases were tried but none of these glowed with such brilliancy. Professors John Trowbridge and T. W. Richards* have called attention to the unusual sensitiveness of an argon tube to oscillating discharges. In order to observe the glow of the tube to the best advantage it is necessary to work in a darkened room.

SOME PRELIMINARY EXPERIMENTS.

(a) *Determination of the Line Constants.*

In this adjustment of the oscillator the primary was made of copper wire 2^{mm} in diameter and was furnished with discharging balls 4^{mm} in diameter. The diameter of the coil was 4^{cm} . The total length of the secondary, including the leading out wires to the first bridge, was about 25^{cm} . In every case the secondary is made of number 18 copper wire. The wave length given out by such a combination when the primary was 3^{mm} from the secondary was 61.33^{cm} . In order to determine the exact wave length one may proceed as follows: Place the argon tube under the wires, in contact with them, and about 14^{cm} from the first bridge. Slide the movable bridge along the wires until the first position of maximum glow is reached; this will be 27.80^{cm} from the first bridge. When the bridge is in the proper position, the maximum glow of the tube may be easily noted from the extension of the glow into the sealing off tube.

Coolidge† found it necessary to connect the first bridge with the earth in order to lead off the irregular vibrations of the oscillator, which otherwise masked the position of the node of the fundamental wave.

I have not found this necessary, however, and attribute it largely to the accurately symmetrical arrangement of the primary and secondary.

Table I contains a set of readings which were taken for the determination of the line constants. In this as in all other cases ten readings were taken in locating the position of a node. The average of two or three such groups for the same node never varied beyond a half of one per cent.

The readings for the nodes most distant from the first bridge are not so concordant, but the percentage of error

* This Journal, vol. iii, p. 19, 1897.

† Annalen der Physik, lxxvii, p. 582, 1899.

TABLE I.

1st node.	2d node.	2d node with balance tube.	3d node.	4th node.
27·65 ^{cm}	58·85 ^{cm}	58·15 ^{cm}	89·25 ^{cm}	120·75 ^{cm}
27·65	58·95	58·00	89·55	120·45
27·80	59·15	58·30	89·50	120·65
27·75	58·75	58·00	89·50	120·55
27·80	59·00	58·20	89·25	121·00
27·80	58·80	58·20	89·60	120·80
27·90	59·15	58·35	89·55	120·80
27·70	59·15	58·15	89·40	120·50
28·00	58·60	58·10	89·55	120·30
27·95	59·00	58·00	89·75	120·50
27·80	58·94	58·14	89·49	120·60

is no greater. Generally a careful adjustment of the three spark gaps will lead to a more brilliant and a more constant glow of the tube. Frequently for various reasons the tube will cease to glow in the dark. If on these occasions white light from an incandescent lamp or a lighted match be permitted to fall on the tube, it will instantly begin to glow. This is no doubt "the effect of ultra violet light upon the electric discharge" which Hertz* has so thoroughly investigated.

Positive and negative surgings start at the middle of the first bridge and meet in opposite phases at the middle of the second bridge, thus forming, according to Hertz, potential loops at points midway between the two bridges and potential nodes at the middle of the bridges. The distance between the middle points of the bridges is a half wave length, the value of which can be found by adding the distance between the two wires to the scale reading. It is doubtful just what this bridge correction ought to be, but the determination of the wave length by another method (given later) seems to confirm the above correction.

This half wave is not the length of a free half wave along the wires. The presence of the tube has added capacity to the wires and thereby shortened the wave. The tube correction must therefore be determined. To do this find the position of the second node. The table shows this to be 58·94^{cm}.

Now place a tube, which we shall call the balance tube, in contact with the wires at the middle of the second potential loop. The wave is now shortened by an amount which is equal to the tube effect. The balance tube ought to be of the same diameter as the argon tube, but its length is not essential

* Electric Waves, p. 63.

provided it extends beyond the two wires. The balance tube as well as the argon tube ought to be within at least $1\frac{1}{2}$ cm of the middle loop, otherwise the capacity effect is lessened.

One-half of this last reading (i. e. the distance between the first bridge and the second node) will give what may be called *the half tube wave*, in which one node rests on the wires and the other rests on the center of the bridge. We shall call the former the *wire node*, and the latter the *bridge node*. The balance tube may now be removed and the third and fourth nodes located, leaving the argon tube at the first potential loop, though as far as the position of the nodes is concerned the tube may be placed at any other potential loop. If we add the tube effect to the average reading in the second column, and also the distance between the two wires, we shall get what may be called a *wave length in air*. (To this is added also a scale correction of 3^{mm}.) This is, in fact, the length of a free wave along the wires, but since the experiments of Sarasin and De La Rive* have shown that the velocity of a rapidly oscillating electrical disturbance along a wire is the same as that in air, we have good authority for calling the above the *wave length in air*.

The same quantity may be secured by subtracting the first reading from the third and the second from the fourth.

Summary of the line constants.

(1)	$58.94 - 58.14 = .80^{\text{cm}} = \text{tube effect.}$	
(2)	$\frac{58.14 + .3}{2} = 29.22^{\text{cm}} = \frac{1}{2} \text{ tube wave.}$	
(3)	$58.14 + 3 + .80 + 1.80 = 61.84^{\text{cm}} = \text{wave length in air.}$	
(4)	$89.49 - 27.80 = 61.69 = \text{ " "}$	
(5)	$120.61 - 58.94 = 61.67 = \text{ " "}$	
	<hr style="width: 20%; margin: 0 auto;"/>	
	$61.73 = \text{average wave length in air.}$	

It will be seen that the wave length in air determined by the first method (3) is very approximately the same as that secured by the second method (4) and (5).

(b) *Determination of the Dependence of the Wave Length upon the Distance between the Primary and the Secondary Coils.*

In this experiment the coils were 5^{cm} in diameter. The primary semicircles were made of 3^{mm} wire and had discharging balls 5^{mm} in diameter. The pitch of the screw controlling the primary was 1.27^{mm}. The primary was removed and re-

* Archives des Sciences et Naturelles Geneve, 1890, xxiii, p. 113.

placed a number of times in order to test the accuracy with which the relative positions of the coils could be reproduced.

In all cases the agreement of the wave lengths was very satisfactory.

TABLE II.

Distance between centers of coils.	Wave length.
2·84 ^{mm}	89·80 ^{cm}
3·15	87·25
3·46	84·80
3·77	80·20
4·08	76·10
4·39	73·05
4·69	71·15

Table II shows the results of this experiment. It will be observed that as the distance between the coils increases the wave length decreases, showing that a decrease in the capacity and mutual induction of the system decreases the period of oscillation.

(c) *Determination of the Relative Velocities of Electrical Waves along Magnetic and Non-Magnetic Wires of Different Diameters.*

In this experiment the coils were 5^{cm} in diameter and the length of the secondary was 48·5^{cm}. The coils were kept at the same distance and the Lecher wires were changed.

TABLE III.

Kind of wire.	Diameter of wire.	Corrected wave length.
Copper	1·00 ^{mm}	81·52 ^{cm}
Copper	2·00	80·84
Copper	3·40	80·80
Iron	1·00	81·70
Iron	1·25	81·56
Iron	1·80	80·36
Iron	2·60	80·86
Copper	1·00	81·08
Nickel	·93	80·90
German silver	1·00	80·88
Brass	1·00	81·10
Copper Secondary	1·00	79·26
Iron Secondary	1·00	79·44

Table III shows the final results. The last two sets of readings shows the comparison of waves produced when the Lecher wires were kept constant and the secondary of the Blondlot oscillator changed. In the first case the secondary was made of copper wire and in the second it was of iron. Great care was taken to make the two secondaries of the same size and shape and to keep the primary and secondary the same distance apart in both cases.

Allowing less than one per cent for error of observations, it is readily seen that the wave lengths for different kinds of wires are practically the same. One concludes from these observations that conductors offer no resistance to the passage of short electrical waves, and that the magnetization of iron is not able to follow oscillations as high as 800,000,000 per second. These conclusions agree with those of Hertz* and Lodge.† But St. John‡ found a difference of wave length in iron and copper of from $1\frac{1}{2}$ to 3 per cent. This difference, however, was for oscillations of 115,000,000 reversals per second.

Dielectric Constant of Paraffin.

Maxwell has shown theoretically that the dielectric constant of a substance is equal to the square of the index of refraction. The index of refraction of a given substance for electrical waves as well as for light waves is the ratio of their relative velocities in air and in the given substance. But since the ratio of the velocity is equal to the ratio of the wave lengths we have

$$K = \mu^2 = \left(\frac{\lambda_a}{\lambda_s} \right)^2 \text{ where}$$

λ_a = the wave length of a given electrical disturbance in air.

λ_s = the wave length of the same electrical disturbance in the given substance.

μ = index of refraction.

K = dielectric constant.

The Blondlot oscillator offers a unique and very satisfactory means of measuring the wave length in air and in the given substance. This means is satisfactory because one is able to keep the oscillator in a constant condition, thus making the wave length in air a constant for a given combination. The method of securing the wave length in air has been described, and it now remains to indicate the way in which the wave length in paraffin may be obtained.

* Electric Waves, p. 113.

† Modern Views of Electricity, p. 101, 1889.

‡ Proceedings of American Academy, p. 218, 1894.

Let us suppose that the oscillator is adjusted for a half wave length of about 40^{cm} . Take a block of paraffin 40^{cm} long, 6^{cm} wide and 8^{cm} thick. It can be readily sawed from a commercial cake by means of a table rip-saw. With this same saw make two grooves 1.8^{cm} apart and half way through one side. Bring the block up under the two Lecher wires, making them lie in the grooves and placing the end of the block against the support of the first bridge. Using a hot iron and a piece of paraffin, run the melted wax into the grooves, thus making a solid column around the wires. Place the argon tube between the free end of the column of wax and the movable bridge. When the oscillator is in action and the tube located, it will be noticed that the distance between the end of the column and the bridge is less than the *half tube wave*. The column may now be cut off piece by piece until the *wire node* of the half tube wave rests on the end of the column. The length of the column plus half the distance between the Lecher wires ($.9^{\text{cm}}$) is very approximately the half wave length in paraffin. In the actual experiment the length of this column was 26.4^{cm} . And if to this we add $.9^{\text{cm}}$ we shall get 27.3^{cm} as the approximate wave length. If the base of the apparatus be long enough for three half waves, a column of paraffin 85 or 90^{cm} long ought to be moulded. For this purpose a box was prepared 90^{cm} long, 8^{cm} wide, and 8^{cm} deep, and was lined with tinfoil. It was put together with screws so that it could be easily taken apart. By a suitable contrivance two copper wires 1.8^{cm} apart could be stretched through the middle of the box and made long enough to be fastened in the two supports of the base. The melted paraffin was poured into the box and allowed to cool partially. Then a closely fitting top was placed on the paraffin and the whole subjected to a pressure brought into play by three iron clamps. A gauge inserted in the side of the box recorded the pressure. All this was necessary in order to secure columns uniformly dense and free from air holes. Having a column thus suitably prepared, one must decide two questions before a final determination of the dielectric constant is made.

1st. How much beyond a node may the end of the paraffin column rest without changing the position of the second bridge?

2d. How large in area must the section of the column be in order to include the whole of the effective field surrounding the Lecher wires?

The first question can be quickly answered. Fasten the moulded column between the supports, making one end rest against the first support. It will be about 3^{mm} from the first bridge, since the bridge rests in a groove 3^{mm} from the outer

surface. Putting the argon tube and the movable bridge beyond the column of paraffin, and locating the first external node (the fourth from the first bridge), it will be found that a node (the third) will rest in the column 6 or 8^{cm} from the end. Saw off a 2^{cm} slab from the end of the column and again locate the node. Continue this until the wire node of the half tube wave rests upon the end of the column. Frequent experiments have shown that if the column be as much as 1.5^{cm} too long or too short, the position of the fourth node is not affected. The conclusion, therefore, is that no error will be made if the column of paraffin be 1.5^{cm} too long or too short, or the end be not against the first bridge. This fact makes it very convenient when using the same column for different wave lengths.

This same column of proper length may be used to answer the second question. After the position of the fourth node has been determined, the column may be removed, and by means of the table saw the section reduced to one 6 × 8^{cm}. The process of locating the node and reducing the section may be continued until the column is too thin to allow further reduction.

TABLE IV.

Size of column.	Area of cross section.	Position of node.	Change in position of node.	Effect on one-half wave length.
7 × 8 ^{cm}	56 ^{sq. cm}	120.34 ^{cm}		
6 × 8	48	120.20		
5 × 7	35	120.35		
4 × 6	24	120.28		
3 × 5	15	120.83	.5 ^{cm}	.2 ^{cm}
2 × 4	8	123.60	3.2	1.1
1.5 × 3.5	5.2	126.68	6.4	2.3
1 × 3	3	131.14	11.8	4.4

Table IV shows the result of this experiment. From it we learn that the effective field, so far as it can be determined by means of an argon tube, certainly lies within a column whose cross section is 5 × 7^{cm}. By a comparison of the values in the fifth column with those in the first, we find that the effect on the half wave varies approximately inversely as the square of the distance of the wires from the outer surface.

Four specimens of the paraffin were secured from a wholesale dealer. They were known as numbers 120, 125, 130 and 135, their numbers representing their melting point on the Fahrenheit scale. Two columns of each kind were prepared and the melting point on the centigrade scale noted. The density was

determined from four different specimens of each column. The total pressure to which the paraffin was subjected when in the mould was 2140 lbs., or 7 lbs. per sq. in. Moulding the columns under pressure was the only way in which masses of this size could be secured of anything like uniform density. The dielectric constant of a column moulded without pressure differed as much as 3 per cent from that of a column of the same kind of paraffin moulded under pressure.

In Table VI will be found the dielectric constant of two kinds of oil, a paraffin oil and a "transformer oil." This grade of paraffin oil is sometimes used for transformers, but the so-called "transformer oil" is said by the wholesale dealers to be the best oil procurable for transformer work. In order to make the necessary measurements with these oils a telescoping box was made and lined with tinfoil. The ends were constructed of thin rubber plates and through them the Lecher wires were stretched. When the nodes rested on or near the rubber ends the wave length in air was not changed by the presence of the box. The box was filled with oil and the length adjusted until the outer end rested on the third node. The box was also filled with melted paraffin and the temperature effect on the position of the node was noted.

Table V shows how the index of refraction and therefore the dielectric constant increased as the temperature decreased. It is very probable that the change of the dielectric constant can be accounted for on the ground of the change in density. The densities at 79° C. and at 18° C. are given in the table.

TABLE V.

Temperature.	Index of refraction.	Dielectric constant.	Density.
79° C.	1.44(7)	2.09(5)	.764
71 C.	1.45(6)	2.12(5)	
65 C.	1.46(3)	2.14(0)	
56.5 C.	1.47(1)	2.16(3)	
53.7 C.	1.47(5)	2.17(6)	
18 C.	1.48(2)	2.19(8)	.908

In order to illustrate the method by which the dielectric constant of each column for each wave length was determined, I have selected a set of readings at random. They are the data secured for column I of the number 120 paraffin.

Diameter of primary	5.00 ^{cm}
Length of wave in air	40.85
Length of tube wave	39.24
Length of column	83.00

Position of fourth node.

1st set of readings.	2d set of readings.
121·90	122·10
121·45	121·60
122·05	122·30
122·00	121·70
122·05	122·30
121·65	122·00
122·10	122·05
122·05	122·30
122·40	121·80
122·15	122·50
<hr/>	<hr/>
121·99	122·07
	122·07
	121·99
	<hr/>
	122·03
	39·24
	<hr/>

82·79 = scale reading for position
of node.

82·79 = scale reading for position of node.

·30 = scale correction.

·90 = bridge correction.

$$3) \overline{83\cdot99}$$

27·99 = length of half wave in paraffin.

$$\frac{40\cdot85}{27\cdot99} = \mu = 1\cdot46(1)$$

$$\left[\frac{40\cdot85}{27\cdot99} \right]^2 = K = 2\cdot13(0)$$

By a very simple device the primary of the oscillator was replaced by one 4^{cm} in diameter and under this was placed a secondary of corresponding diameter. With this combination the half wave in air was 30·66^{cm}. With a 3^{cm} primary the half wave in air was 20·85^{cm}. By a happy coincidence which was not altogether fortuitous, the columns were long enough to contain within the limit of error three half waves of the 5^{cm} primary, 4 half waves of the 4^{cm} primary, and 6 half waves of the 3^{cm} primary.

Table VI exhibits a comparison of the melting points, densities, indices of refraction and dielectric constants of the paraffins and the two kinds of oils for the three different wave lengths. The dielectric constant of the oils, however, was determined for only one wave length. In the last two columns will be found the light index of refraction for the D line and the corresponding dielectric constant. A comparison of

TABLE VI.

Kind of paraffin.	Observed melting point.	Density.	$1/2\lambda=40.84\text{cm.}$		$1/2\lambda=30.66\text{cm.}$		$1/2\lambda=20.84\text{cm.}$		$\lambda=.00005896\text{cm.}$	
			μ	K	μ	K	μ	K	μ	K
No. 120	47.6° C.	.894	1.46(2)	2.13(7)	1.47(0)	2.16(1)	1.48(8)	2.21(7)	1.5380	2.3655
No. 125	50.2° C.	.905	1.47(3)	2.18(0)	1.48(9)	2.21(8)	1.50(4)	2.26(2)	1.5430	2.3808
No. 130	53.3° C.	.907	1.48(3)	2.19(8)	1.49(3)	2.22(0)	1.50(2)	2.25(6)	1.5505	2.4044
No. 135	56.2° C.	.897	1.49(0)	2.22(1)	1.50(1)	2.25(4)	1.51(2)	2.28(6)	1.5523	2.4098
Paraffin oil	309° flash	.905	1.54(3)	2.38(1)					1.5050	2.2650
Transformer oil		.823	1.48(7)	2.21(3)					1.4565	2.1711

the dielectric constants for any given substance will reveal the fact that in every case there is a gradual increase as the wave length decreases, even including the light wave. These results certainly indicate the analogous behavior of electrical and light waves. A comparison of the dielectric constants of the different paraffins shows that these constants increase with the melting point. From these experiments it seems necessary, therefore, in tabulating the dielectric constant of paraffin, to give its density, its melting point, and the wave length for which the constant was obtained. The third decimal place is bracketed because the accuracy of measurements does not warrant its unqualified use, and yet the quantities of which the tabulated numbers are the average are of such uniformity that some credence must be given to this third place.

Light Index of Refraction.

The light index of refraction was obtained by means of an Abbe* refractometer. This is constructed upon the principle of total reflection and is graduated to read directly the index of refraction of the D_1 line of any transparent liquid or solid which can be placed between its prisms. Films of paraffin were easily procured by floating bits of wax on hot water and allowing the melted wax to solidify. In order to insure close contact, both the film and the prisms were gently heated before the wax was placed before the prisms. The refractometer gave data also from which by means of a table one could calculate the dispersion factor between the D_1 and the F lines.

Having the index of refraction for two lines in the spectrum,

* Physikalischer Praktikum, Wiedemann-Ebert.

one may apply Cauchy's formula and thus obtain the index for infinitely long waves. When the constants A and B of this formula are eliminated, it takes, according to Gordon,* the following form:—

$$\mu_{\lambda=\infty} = \frac{\mu\lambda^2 - \mu_1\lambda_1^2}{\lambda^2 - \lambda_1^2} \quad \text{where}$$

$\mu_{\lambda=\infty}$ = index of refraction for infinitely long waves

μ = " " " a given long wave

μ_1 = " " " a shorter wave

λ and λ_1 represent the corresponding wave lengths.

TABLE VII.

μ_1 for $\lambda = 81.64\text{cm.}$	μ_2 for $\lambda = 41.64\text{cm.}$	μ_0 for $\lambda = \infty.$	μ'_1 for D ₁ line.	μ'_2 for F line.	μ'_0 for $\lambda = \infty.$
1.46(2)	1.48(8)	1.45(6)	1.5380	1.5567	1.498
1.47(3)	1.50(4)	1.46(2)	1.5430	1.5589	1.509
1.48(3)	1.50(2)	1.47(7)	1.5505	1.5665	1.513
1.49(0)	1.51(2)	1.48(5)	1.5523	1.5684	1.519

Table VII shows the results obtained from the application of this formula to the light indices and also to the electrical indices. The values of the sixth column should agree with those of the third. They should at least be less than the index found for the longest wave. This formula does not appear to fit the experimental facts.

Conclusions.

1. For reversals as high as 800,000,000 per second the velocity of electrical disturbances along magnetic and non-magnetic wires of different diameters is the same, thus showing that the magnetic properties of iron are not able to follow such rapid changes.

2. The effective field around the Lecher wires as far as it can be detected by means of an argon tube, does not extend more than 3^{cm} from the wires, and the effect on the half wave within this region varies approximately inversely as the square of the distance from the wires.

3. The dielectric constant of a given paraffin increases with the density of the paraffin. It increases rapidly from a temperature 20° above the melting point to a temperature 30° below the melting point. Among different paraffins the dielectric constant increases as the melting point of the paraffin increases.

4. The dielectric constant increases as the wave length decreases. It is greater for short light waves than it is for short electrical waves. Cauchy's formula as a means of obtaining the index of refraction for indefinitely long waves does not meet the experimental facts.

Jefferson Physical Laboratory, Harvard University.

* Philosophical Trans., pt. I, p. 441, 1879.

ART. XLVII. — *On Some New Mineral Occurrences in Canada*; by G. CHR. HOFFMANN, of the Geological Survey of Canada. (Communicated by permission of the Director.)

1. *Datolite.*

A specimen of a mineral was recently submitted to the writer for identification, which had been met with by Mr. Bush Winning in some abundance in the workings of the Daisy mica mine on the ninth lot of the first range of the township of Derry, Ottawa County, in the Province of Quebec. This mineral proved, on examination by Mr. R. A. A. Johnston, to be datolite.

Mr. R. L. Broadbent has since visited the mine in question and collected a fine series of specimens which not only fully illustrate its mode of occurrence, but likewise its various mineral associations. On transferring these specimens to me, Mr. Broadbent drew my attention to some small white, occasionally colorless, octahedral crystals which he had observed on some of them. These crystals, more fully referred to further on, were also examined by Mr. Johnston, and identified by him as the somewhat rare mineral, *faujasite*, a species not previously recognized as occurring in Canada.

The datolite occurs in the form of hard, compact, irregularly shaped, at times more or less nodular, masses some of which are of quite small dimensions, while others are of considerable size—one having been found which measures six inches across and weighs thirteen pounds. It has also occasionally been met with in the form of moist, plastic masses, which on exposure to the air become crumbly and ultimately fall to pieces, forming a loose earth. The masses in question occur imbedded in a matrix composed of an association of a light to somewhat dark greenish-gray, more or less weathered, pyroxene, brown phlogopite, light grayish to white cleavable calcite, grayish-white translucent to colorless transparent quartz, and bluish-green, more rarely faint purplish, yellowish and colorless fluorite, with some intermingled pyrite and pyrrhotite, and small quantities of barite, chabazite and *faujasite*.

The mineral is greenish-white to all but white in color; is almost opaque; has a dull luster; is brittle; breaks with an uneven to subconchoidal fracture—the fractured surface resembling that of fine stone-ware (Wedgewood-ware). It has a hardness of 5, and a specific gravity, at 15.5° C., of 2.985. Before the blowpipe, it fuses, with slight intumescence, at about 2 to a clear glass, simultaneously coloring the flame

yellowish-green. In fine powder, it is easily and completely decomposed by hydrochloric acid, with separation of gelatinous silica.

The mean of two very closely concordant analyses, conducted by Mr. Johnston, showed it to have the following composition :

Silica	36.94
Boron trioxide	22.37
Lime	34.90
Alumina	0.12
Ferric oxide	0.02
Magnesia	0.05
Water (direct estimation)	5.68
	100.08

2. *Faujasite.*

This species, which has been briefly alluded to in the preceding note as being one of the mineral associations of the datolite, found at the Daisy mica mine, on lot nine of the first range of the township of Derry, Ottawa County, in the Province of Quebec, is there met with in the form of simple octahedral crystals implanted upon the walls of small cavities in the quartz or intimately associated with the fluorite (in some instances being, indeed, included in crystals of the latter mineral), both of which enter largely into the composition of the matrix of the datolite. The crystals vary in size from such as are of almost microscopic minuteness to others having a diameter of about two millimeters. They are mostly milk-white—with, in some instances, a faint greenish tinge, in color, and opaque, occasionally, however, colorless and translucent, and have a vitreous luster. In the closed tube the mineral yields much water. Before the blowpipe, it intumescs and fuses to a white blebby enamel. It is decomposed by hydrochloric acid without gelatinization. An analysis of the same has been entered upon.

ART. XLVIII.—*The Estimation of Molybdic Acid reduced by Hydriodic Acid*; by F. A. GOOCH and O. S. PULMAN, JR.

[Contributions from the Kent Chemical Laboratory of Yale University—CIV.]

WHILE the determination of molybdic acid by estimating the iodine set free upon boiling a solution of that acid in hydrochloric acid to which potassium iodide has been added, is a possibility, the operation is beset with difficulties. If due attention be paid to the proportion of acid, the excess of potassium iodide over the amount theoretically necessary to produce the ideal reduction, and the final degree of concentration of the liquid, the change of the molybdic acid to the condition of oxidation of the pentoxide, Mo_2O_5 , may, as has been shown in former articles from this laboratory,* be closely realized. Even when the conditions essential to the ideal reduction obtain, however, the possibility of the interaction of atmospheric oxygen with the hydriodic acid produced from the potassium iodide and hydrochloric acid must be guarded against by conducting the operation in an atmosphere of carbon dioxide. Furthermore, the hydrochloric acid employed must be freed, so far as may be, from dissolved oxygen by previous boiling. The operation is capable of yielding accurate indications (unless by a chance combination of opposite errors) only when the precautions mentioned are scrupulously observed.

On the other hand, the essential principles of the reaction admit of very simple application when the residue of the distillation, instead of the iodine distilled, is made the object of the analytical determination. This was the plan of a method formerly proposed.† In this process the mixture of molybdic acid, potassium iodide and hydrochloric acid was boiled between defined limits of volume in an Erlenmeyer flask simply trapped to prevent mechanical loss during the boiling, and the residue, after the removal of all free iodine, was treated with tartaric acid to prevent subsequent precipitation, neutralized with an alkaline bicarbonate, and reoxidized by a measured excess of standard iodine, this excess of iodine being finally determined by titration with a standard arsenite. The difference between the iodine value of the arsenite used and the amount of standard iodine employed measures the molybdic acid. The action of atmospheric or dissolved oxygen obviously plays no important part in the operation providing all uncombined iodine, however produced, is finally boiled out. At the outset iodine is liberated by the air present as well by the intended action of the molybdic acid, but as the boiling continues the hydriodic acid diminishes in strength, the iodine is driven from the flask kept filled with steam, and if the conditions of the operation have been properly adjusted the molyb-

* Gooch and Fairbanks, this Journal, ii, 156; Gooch and Norton, this Journal, vi, 168.

† Gooch and Fairbanks, this Journal, ii, 160.

dic acid undergoes the ideal reduction. When this point is reached dilution with cold water obviates danger of immediate oxidation and gives opportunity for continuing the treatment referred to above. The method yields accurate results, but is tedious on account of the delay of an hour and a half to two hours before the excess of the iodine introduced to reoxidize the molybdic acid can be safely titrated by the arsenite. Taking the matter up again at this point, we find that it is perfectly feasible to obviate the difficulty in question and to secure immediate reoxidation of the molybdic acid by substituting potassium permanganate for iodine as the oxidizer.

When an excess of potassium permanganate is added to a solution containing hydrochloric and hydriodic acids with molybdenum in a condition of oxidation corresponding to the pentoxide, several different effects of oxidation may be expected. There is the immediate liberation of iodine from the hydriodic acid, the production of iodic acid, some slight tendency to liberate chlorine from the hydrochloric acid, the formation of representatives of the higher oxides of manganese, and, lastly the reproduction of the molybdic acid, which is the object of the operation. All other effects than the last must be prevented or recorded in order that the estimation of the molybdic acid may be accomplished. Of the secondary actions, the liberation of chlorine may be prevented by adding a manganous salt, according to the well-known proposals of Kessler* and Zimmerman,† the iodine set free may be converted to hydriodic acid again by the introduction into the acid solution of a sufficient excess of a standard arsenite solution; the iodic acid may be reduced in the acid solution in the same manner, as we have found by experiment, the value obtained for a solution of iodic acid by adding to it in presence of sulphuric acid a measured amount of standard arsenite, making alkaline, and titrating back with iodine, being the same as that found by acting directly upon the iodic acid with an excess of potassium iodide in presence of dilute sulphuric acid and determining by standard arsenite the iodine liberated; and the higher oxides of manganese are likewise reduced in the acid solution by the arsenious acid of the standard arsenite.

Whatever excess of arsenious acid is left over after the reactions described may, obviously, be determined by neutralizing the solution with an alkaline bicarbonate and titrating with iodine.

Every difficulty introduced by the secondary oxidations should, it might be supposed, be overcome by adopting the following procedure: the addition of manganous sulphate to the reduced, diluted, and cooled solution; the introduction of measured standard potassium permanganate until its char-

* Ann. Phys., cxviii, 48; cxix, 225-226.

† Ann. Chem. (Liebig), ccxiii, 302.

aeteristic color is evident ; the treatment of the solution with a measured amount of standard arsenite in known excess ; the neutralization of free acid by potassium bicarbonate, first taking pains to introduce, after the destruction of the permanganate by the arsenite, tartaric acid to prevent precipitation of the molybdenum compound ; and the titration of the excess of arsenite by iodine.

The operation requires the use of a standard solution of arsenite, easily made with accuracy, a solution of iodine in potassium iodide standardized directly against the arsenite in the usual manner, and a solution of potassium permanganate the value of which in terms of the arsenite is found by

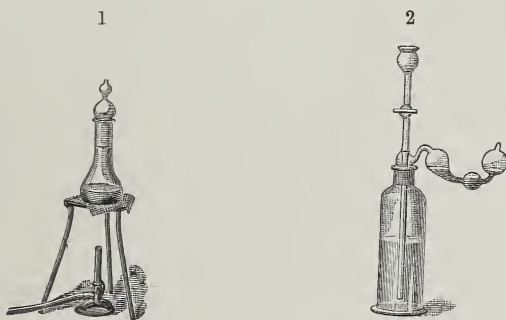

bleaching a measured portion of it with an excess of arsenite and titrating back with iodine the arsenite remaining. The preparation and adjustment of the standard solutions is therefore simple. The theory of the operation is plain, the value (in terms of molybdic acid) of the permanganate used, diminished by that of the arsenite and increased by that of the iodine, giving the amount of molybdic acid present.

In carrying out our tests of the method proposed we used a preparation of ammonium molybdate made by recrystallizing the presumably pure salt. The constitution of this salt was determined by careful ignition, both by itself and with sodium tungstate free from carbonate. It held 81.83 per cent. of MoO_3 .

From 0.3 gram. to 0.5 gram. of the molybdate, at least 20^{cm^3} of hydrochloric acid of sp. gr. 1.20, with from 0.2 gram. to 0.6 gram. of potassium iodide, according to the amount of molybdate used, were put into a 150^{cm^3} flask, trapped loosely by means of a short bulbous tube hung in the neck, as shown in figure 1. The solution was boiled until the original volume of 40 to 60^{cm^3} had been reduced to exactly 25^{cm^3} as determined by a mark upon the flask, the base of which was of a size permitting close reading of the volume of the liquid. The residue was diluted immediately to a volume of 125^{cm^3} and thus cooled, transferred to a Drexel wash-bottle, shown in figure 2, fitted with a ground glass stopper carrying the usual inlet and outlet tubes. To the inlet tube had been sealed a

separating-funnel to serve for the gradual introduction of reagents, and to the outlet tube a Will and Varrentrapp bulb tube charged with a solution of potassium iodide to catch any traces of iodine thrown off mechanically during the process of neutralization to follow. Through the separating funnel were then added 0.5 grm. of manganese sulphate, and from a burette an approximately $\frac{n}{10}$ solution of potassium permanganate of known value until the characteristic color was given to the solution, the amount of permanganate thus added being noted. Then, from a burette, was added enough of a standard arsenite solution to correspond approximately to the value of the permanganate used; experience having shown that this amount of arsenite is sufficient to reduce with readiness in the acid solution the iodic acid, the permanganate, the higher oxides of manganese, and nearly all the free iodine, the remainder of the last being taken up immediately after the subsequent neutralization. The amount of this solution was noted. Next a solution of about 3 grm. of tartaric acid was run in, and the free acid of the solution was neutralized by acid potassium carbonate. This accomplished, the liquid adhering to stopper and tubes was washed off into the bottle, the contents of the trap added, and the residual arsenite was titrated by standard iodine, using the starch indicator.

The results of experiments are given in the following table :

Weight of MoO ₃ taken as ammonium molybdate. gram.	Weight of KI used gram.	Weight of MoO ₃ found. gram.	Error. gram.
0.0423	0.2	0.0430	0.0007 +
0.0429	0.2	0.0435	0.0006 +
0.0420	0.2	0.0427	0.0007 +
0.0827	0.3	0.0829	0.0002 +
0.0837	0.35	0.0838	0.0001 +
0.0826	0.5	0.0832	0.0006 +
0.2465	0.6	0.2460	0.0005—
0.2481	0.6	0.2469	0.0012—
0.2470	0.6	0.2465	0.0005—

It is plain that molybdic acid may be determined with accuracy by reduction under the prescribed conditions with potassium iodide and hydrochloric acid, treatment of the residue with manganous sulphate, standard potassium permanganate, standard arsenic, and, after addition of tartaric acid and neutralization, titration with iodine. When many determinations are to be made the process will yield results with rapidity, because as many operations can be started successively in the Erlenmeyer flasks as an operator can handle with convenience, a simple neutralization bottle serving for the treatment of all the reduced residues as they come along.

ART. XLIX.—*The Veramin Meteorite*; by HENRY A. WARD.

THIS most interesting Oriental meteorite, which fell in northern Persia in 1880, was first made known in Europe by Fred. Dietsch, a German mining engineer, who gave a short account of it on page 100 of vol. xl of the *Berg and Hüttenmännische Zeitung*, March 18, 1881. His notice was based upon information given him personally by the Shah, who handed him, in confirmation of his words, a fragment of the stone weighing 400 grams. Subsequently Baron Emil Gödel-Lannoy, secretary of the Austrian legation of Teheran, brought two small pieces of the stone to Vienna. One piece, weighing 28 grams, he presented to Baron von Braun; the other, weighing 28 grams, he gave to his friend Dr. Aristid Brezina, who incorporated it in the great meteorite and mineral collection of the Royal Museum, of which collection he was then the director. Brezina described this in a paper before the K. Akademie der Wissenschaften in July, 1881, giving in few words the mineral composition of the fragment with its petrographical characters; but the material was too scanty for a full analysis, and nothing was known about the main mass beyond the fact inaccurately reported, that its weight was 45 kilograms, and that it was preserved in the palace of the Shah. So matters remained with Veramin—thus the stone had been called—until the autumn of 1898. At that time I was in Stockholm, where I saw a small fragment of the stone in the hands of Baron Nordenskiöld, who informed me that it had been brought to him from Teheran by a returned Swedish servant (barber) of the Shah. As I had long projected a visit to Persia, and as Veramin had come to have strong attractions for me, I decided that I would at once undertake the long trip. A week later, at St. Petersburg, I obtained through the good offices of our legation an introduction to the Persian ambassador in that capital. That gentleman, Gen. Mirzah Riza Khan, interested himself in my intentions, and gave me several letters to officers of the Shah's court, among them one to Muskah-es-Sultanneh, the Grand Vizier. After first crossing Russia and the Caucasus range to Tiflis in the Transcaucasus, and eastward to Baku on the Caspian, I took steamer down that sea to Enzeli, the port of northern Persia; thence eight days of horseback and two of carriage brought me to Teheran.

After a few days in this city I obtained audience with the Grand Vizier at his private palace. He spoke and understood French, so I told him in simple, unvarnished words the object

of my visit to his country. I had heard in far-distant America of a famous stone which had fallen from heaven many years ago, and was now in the palace of the Shah. That I wished to see it, to examine, weigh and photograph it; and also, if possible, to obtain a piece of it for my collection of these wonderful objects. His excellency informed me that it would be possible to bring about most of my requests as stated, but that he doubted very much my being able to obtain a fragment, even ever so small, of the precious and somewhat celebrated stone. He would, however, at an early day be called to see his Majesty the Shah, and he would then bring up the subject, and ascertain what might be done. In fact, after a few days' delay I received a letter from the Grand Vizier, enclosing word from the Shah inviting him to call on the following day with me and with the American Ambassador, Mr. Arthur Hardy, who had interested himself actively on my behalf. We went promptly the next day. We were joined at the grand outer stairway by the Guardian of the Palace and one or two court attendants, and with them we proceeded at once to the hall of the Peacock Throne, where the audience was to be given. At the further end of the hall, and immediately in front of the throne stood his Imperial Majesty, the Shah, Mozuffer-el-Din (Victorious of the Faith), whom it is proper on such occasions to address as "King of Kings" or "Asylum of the Universe."

I must not dwell upon this interview, interesting as it was in many ways.

The conversation turned chiefly upon meteorites. His Majesty was curious to know more or less about their place of origin, the places in which they had fallen, their general composition, and particularly if any of them contained silver or gold. One point in my conversation with the Shah particularly interested me: This was when, turning to the Guardian of the Palace, who stood at his right, he made some remark illustrated by the fingers of one hand crossing the other, at which the Grand Vizier, interpreting to me, said: "His Majesty says that you may have a piece of the meteorite." This declaration having been made, and I having duly given my thanks, the audience ended.

On our way down the long hall we had our first view of the famous meteorite, which was on a low stand under a window. By its side was a large cardboard label which gave in beautiful Persian characters the short and only preserved account of the fall. I here give the translation, which was kindly made for me by our American Consul, Mr. Edward Tyler.

Translation.

On the 8th of Jamadi-ul-aval A. H. 1298,* at a place called Boogin, the winter quarters of the tribe of Bagadi Shahsevan, about three hours before sunset, there appeared in a clear sky, between Boogin and Eshtahard, a small cloud, followed immediately by an appalling noise. The people were greatly moved, and rushed to their tent doors. While standing there in expectation, they heard nine more terrific explosions, like to the reports of a cannon. Following upon these, something resembling smoke proceeded from the cloud, clearly visible to all the people, descended to the earth and buried itself about seven feet in the ground. A shepherd near the place noticed the exact spot, and with fear and trembling pointed it out to the people. Some of them went and turned up the ground and took out the stone. Hadayat ullah khan, Kajar, the son of the late Eesa Khan Beglerbegee, Governor of the tribe, took possession of the stone, and reported the occurrence to Teheran and sent the stone there.

It will be seen that this label gives the locality of the fall of the meteorite as Boogin. But as no map which I have consulted shows any of these places here mentioned, and as the Palace people called it Veramin, the same name by which Dietsch noted the stone a few months after it fell, it seems proper that his name should be retained. Veramin is a small plain in the District of Karand some fifteen miles eastward of Teheran.

As we descended the staircase, the Guardian of the Palace informed me that his Majesty would soon go to the mountains for a week's hunting, and that then would be a proper time for me to come to the Palace to carry out my work. Accordingly, after two days I returned with a German photographer, whose services I had engaged, and a Persian servant bearing a huge pair of scales, which I had borrowed at the hotel. We put the meteorite on the scales and found that its weight was just $113\frac{1}{2}$ pounds (about $51\frac{2}{5}$ kilograms). The stone was shaped like an oblong loaf, about 16 inches in greatest length, 12 inches wide, and with a varying thickness of 7 to 8 inches. The weight of the mass seemed quite inconsistent with the fact that it seemed exteriorly to be largely stone. Its corners were much rounded, and its surfaces covered with characteristic deep pittings. The largest of these pittings was one inch across and half an inch deep; most of the others about one-half these dimensions. About three-fourths of the surface was

* Although I have sought among members of the Persian Legation in several European capitals, I have been quite unable to ascertain the exact equivalent in our (Christian) Calendar of the Persian date given above. All seem to agree on the month of May, 1880, but hesitate to fix the *day*.—H. A. W.

thus covered; while interspersed were patches with the peculiar tiny vaceolar "goose skin" depressions often seen on the outer rind of iron meteorites, where they seem to be a phenomenon of the cooling of the crust. The lower side of the mass is more irregular and rough, with apparently little crust, but it has a thin coat of mud still adhering to it, acquired doubtless while it lay for several days by a tank in the Palace yard. A fine, thread-like black line, faintly distinguishable,

1



Veramin. About $\frac{1}{3}$ nat. size.

passes obliquely across the face, and is clearly a line of flowing. This is $12\frac{1}{2}$ inches long, and it, with several shorter lines of coinciding direction, shows clearly the direction of the stone in its passage through the air. Certain small areas of the mass are veneered by a flake of thin iron. Some of these appear to enter the mass as thin plates. The crust or rind of the meteorite is of a dull grayish brown color, and is excessively thin, a mere varnish. Through this rind project countless little points of metallic iron, making little burrs or sharp protuberances on the surface, which have often been flattened or blunted. The surface shows also a few little buttons, barely 2^{mm} across, of black, shining iron oxide; with one or more nodules, from 5 to 10^{mm} in diameter, of crystalline honey-yellow olivine. The ends of the stone have been much abraded by

blows given in an effort to break off fragments. The general appearance of these broken parts is a dull, coarse-grained base or cement, with some larger, crystallized, angular grains imbedded. These broken surfaces are very rough and prickly to the touch, and the glass showed sharp points and granules of white iron intimately sprinkled in with a filling of oily green, glassy olivine. M. Tholazan in 1884* described the inner constituents of the stone, giving them as "bronzite"; a green, infusible and almost insoluble silicate, probably peck-

2

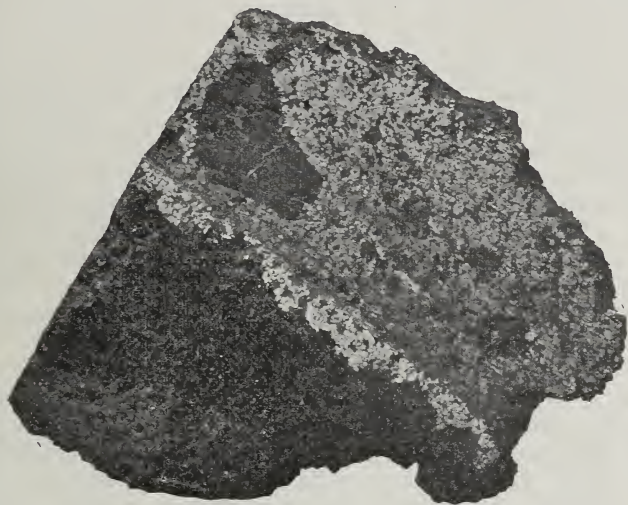

Section of Veramin. $\frac{3}{8}$ nat. size.

hamite; and granules of nickel iron;—all cemented by a fine network of nickel iron. Merrill, after examining a small fragment sent by me to him at Washington, writes me: "I make out the presence of enstatite, olivine; a colorless (in the section) mineral giving an inclined extinction as high as 29° which may be peckhamite: and in addition granules of clear, colorless feldspars, showing distinctly twin striae, and giving an extinction-angle of 30° . This indicates a basic member of the albite-anorthite series, perhaps bytownite or it may be anorthite."

The polished section of the mass, as seen in the enclosed cut, has a very close resemblance to the Miney meteorite from Taney Co., Missouri. There is the same compact base of the fine-grained elements, both stony and metallic, with segregated patches of each of them in which the matrix is at once more homogeneous and of coarser structure. Besides the myriad

* Comptes Rendus, Paris Acad., vol. xcviij, p. 1465.

granular particles of bright nickel iron, there are occasional nodules of the same element of larger size. One of these which I separated from the mass is a perfect sphere, 8^{mm} in diameter, which lay almost free from attachment except that upon one side it is incrustated by a portion of the firm base mass. A section of this shows it to be a solid metal, which, when a polished surface is etched, gives clearly sharp Widmannstätten figures of a clear pattern. Meunier classes Veramin as a member of his type of Logronite, including with it Barea, Sierra de Chaco, Janecera, Estherville, Miney and Hainholz. Of these seven, but two, Estherville and Veramin, have any crust.

Of about twenty-five siderolites now known to science, only four of them have been *seen to fall*. Veramin has an additional interest as being one of these four. The other three are Barea (Spain) 1842, Lodran (India) 1868, and Estherville (Iowa) 1879. It may not be irrelevant here to call attention to the interesting fact that the siderolites, with their special composition and structure, have been as widely distributed both in time of fall and in geographical dispersion on our globe as have either of the other two—alike artificial—groups of meteorites: the siderites and the aerolites. This seems to attest to each group representing a class of rocks, or mineral aggregations, existing abundantly in some of the asteroids or fragmentary bodies circling in the celestial spaces.

In closing, I return to the narrative portion of my paper to notice the extreme difficulty which I had in breaking the Veramin, due to the very intimate mingling of its stony and its metallic parts. Had the mass been a siderite, I might have cut it with my steel saw, or had it been an aerolite I might have broken off a piece with a hammer; but the intimate mingling of its stony and its metallic parts made a compound so tough that separation seemed quite impossible. After working over the mass, which I had taken to the Palace yard, for several hours, and assisted by a native smith with a large, long-handled hammer, we had failed to detach more than a few ounces of the precious material. It then occurred to us that we should take the meteorite to the arsenal and there undertake to cut it by machinery. The fortunate presence there of an old steam planing machine was in our favor. Steam power, however, there was none. In its absence we harnessed ten or twelve men by ropes at either end of the planer. Yet so hard and refractory was the mass that the work of cutting off a piece barely six inches in greatest diameter required two nights and one day. Then I took my piece and hastened back to Europe. This fine mass of this very rarest of siderolites forms one of the choice specimens in the Ward-Coonley collection of

meteorites now on display (on deposit) in the Geological Hall of the American Museum of Natural History in New York.

As to the composition of Veramin I give here the results of a careful analysis made for me by Prof. J. Edward Whitfield of Philadelphia.

The specific gravity of the stone as received was 4.57.

On separation the stone was found to be made up of 42.3 per cent mineral and 57.7 per cent metal, although the portion separated as mineral contains some iron oxide, which originally must have been metal. Of the metallic portion the specific gravity is 5.56, rather a low figure for metal of this composition.

It was extremely difficult to entirely separate the mineral matter from the metal; although the small particles were hammered until about the thickness of tissue paper, there was an amount of insoluble remaining with it amounting to 9.28 per cent, this of course including any silicon of the metal as silica.

The analysis of the metallic portion, excluding all the insoluble as mineral matter, is as follows :

Iron	92.06	per cent
Nickel	6.96	"
Cobalt	0.73	"
Phosphorus.....	0.10	"
Sulphur	0.15	"

It was impossible to obtain even a trace of carbon with the small amount of material at hand, and whether or not the metal contains silicon, I cannot say on account of the difficulty of obtaining the metal free from mineral matter. The analysis was made on an amount approximating four grams, any other determinations being impossible for want of material.

J. E. W.

SCIENTIFIC INTELLIGENCE.

I. CHEMISTRY AND PHYSICS.

1. *Double Compounds of Antimony Pentachloride, etc.*—

ROSENHEIM and STELLMANN have obtained a pyridine-antimonic double chloride having the formula $3C_5H_5NHCl \cdot SbCl_5$, and also analogous quinoline and dimethylaniline double salts. These compounds are interesting, inasmuch as very few double halides of quinquivalent elements are known. These chemists have prepared also a pyridine-antimonic double bromide, $2C_5H_5NHBr \cdot SbBr_5$, which shows for the first time the existence of antimony pentabromide, and they believe that they have isolated the uncombined pentabromide. They have succeeded in preparing also a remarkable series of compounds of antimonic chloride with organic compounds containing oxygen. Such compounds with alcohols and ether were described by Williams many years ago, but the present list shows that antimonic chloride is capable of combining with many classes of compounds. It forms with acetaldehyde $SbCl_5 \cdot CH_3CHO$; with benzaldehyde $SbCl_5 \cdot C_6H_5CHO$; with acetone $SbCl_5 \cdot (CH_3)_2CO$; with ethyl benzoate $SbCl_5 \cdot C_6H_5COOC_2H_5$; with benzoyl chloride $2SbCl_5 \cdot 3C_6H_5COCl$; with acetamide $2SbCl_5 \cdot 3CH_3CONH_2$; with phthalic anhydride $2SbCl_5 \cdot 3C_6H_4C_2O_3$; with succinic acid $2SbCl_5 \cdot C_2H_4(COOH)_2$.—*Berichte*, xxxiv, 3377.

H. L. W.

2. *The Thermochemistry of Alloys.*—In order to determine the heat of combination of a series of copper-zinc alloys, T. J. BAKER has dissolved the finely-divided alloys in a calorimeter by means of solutions of ferric chloride and of cupric chloride. Both of these solutions contained ammonium chloride; they dissolved the metals rapidly without evolution of gas, and the two solutions gave closely agreeing results. The amounts of heat produced by dissolving the alloys were then compared with results obtained by dissolving mixtures of the uncombined, powdered metals, and in every case the alloy gave a smaller amount of heat, the deficiency expressing the heat of combination of the two metals. It was found that the heat of solution of 1 gram of pure copper was 179 cal., while the corresponding value for zinc was 927 cal. When mixtures of the two metals were taken, results were obtained which corresponded to those calculated from the above values. In the alloys the greatest heat of combination, amounting to 52.5 cal. per gram, was found to occur where 32 per cent of copper was present. This corresponds to the formula $CuZn_2$ and indicates the existence of a compound of this composition.—*Zeitschr. physikal. Chem.*, xxxviii, 630.

H. L. W.

3. *Acid Nitrates.*—More than twenty years ago an acid potassium nitrate and two acid ammonium nitrates were described by Ditte. These salts attracted little attention, probably because they were formed at low temperatures and were very unstable, and the opinion seems to have prevailed up to the present time

that nitric acid, being monobasic, is incapable of forming acid salts. WELLS and METZGER have recently found that rubidium and caesium each form two acid nitrates which are comparatively stable, and they have also prepared an acid thalious nitrate. Ditte had made the thalious salt and one of the rubidium salts, but he did not use the proper method for obtaining them in a pure condition, and consequently did not ascertain their true compositions. The recent additions and revisions give the following list of acid nitrates :

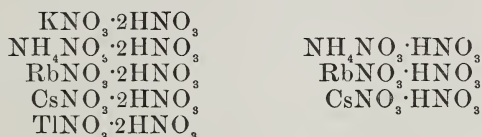

The caesium and rubidium salts form large colorless crystals which, although somewhat unstable, may be readily handled at ordinary temperatures ; in fact, $\text{CsNO}_3 \cdot \text{HNO}_3$ is so stable that it shows a sharp melting-point at 100° . The potassium, ammonium and thallium acid nitrates have low melting-points, varying from -3 to 18° , so that they require low temperatures for their formation. The diacid salts are produced by dissolving the normal nitrates in nitric acid of 1.50 sp. gr. and cooling to crystallization, while the monacid salts are similarly prepared from acid of 1.42 sp. gr.—*Amer. Chem. Jour.*, xxvi, 271. H. L. W.

4. *Methods of Standardizing Acid Solutions.*—CYRIL G. HOPKINS has compared six different methods of standardizing volumetric acid solutions. He finds that the determination of chlorine in hydrochloric acid by weighing silver chloride in a Gooch crucible gives more closely agreeing results than the other methods that he has tried, while neutralizing sulphuric acid with ammonia, evaporizing to dryness, heating the residual ammonium sulphate to 120° , and weighing it (Wenig's method) also gives very satisfactory agreements. The method of Hart and Croasdale, which consists in electrolyzing copper sulphate, weighing the precipitated copper, and using the liberated sulphuric acid as the basis, gave rather poorly agreeing results. Hartly's method of standardizing with metallic sodium was found to be unreliable, apparently on account of impurities in the sodium. Rimbach's method, by use of crystallized borax with methyl-orange as an indicator, was found to be unsatisfactory, because the borax gradually lost water of crystallization in the air. This is contrary to Rimbach's experience, and is probably due to a difference in atmospheric conditions. The method of standardizing oxalic acid by means of potassium permanganate solution, the latter being compared with metallic iron, is stated to give fairly good results. It would be interesting if the author had included several other methods in his comparison ; for instance, Grögger's method, which is based on the liberation of iodine by the action of an acid upon potassium iodate and iodide, and also the very

widely used sodium carbonate method.—*Jour. Amer. Chem. Soc.*, xxxiii, 727.

H. L. W.

5. *New Element Associated with Thorium*.—By treating an ordinary thorium chloride solution with sulphurous acid and boiling, CHARLES BASKERVILLE has found that a precipitate is produced which gives an oxide of lower specific gravity than a part of the earth not precipitated by this means. By other processes of fractionation he has obtained similar results, and he believes that the heavier oxide contains a new element for which he proposes the name Carolinium with the symbol Cn. It is to be hoped that at last a well-characterized new element is to be described in this country, but we must wait for further details before deciding whether this is a new element or a mixture of old ones.—*Jour. Amer. Chem. Soc.*, xxiii, 761.

H. L. W.

6. *A Laboratory Guide to the Study of Qualitative Analysis*, by E. H. S. BAILEY and HAMILTON P. CADY. 8vo, pp. 234. Philadelphia, 1901 (P. Blakiston's Son & Co.).—The importance of teaching the ionic theory to some extent in connection with the facts observed in the study of qualitative analysis is now widely recognized. The book under consideration begins by giving in an introduction an elaborate explanation of electrolytic dissociation and the mass law. If a student could understand this introduction, he would be far beyond the need of a course in qualitative analysis; for here are introduced the equilibrium of "phases" and many quantitative conceptions, including a mathematical treatment of the mass law, which it would be better to present to the student after an extensive course in both qualitative and quantitative analysis, rather than as an introduction to the first of these subjects. The ionic idea is carried to the utmost limit throughout the book, and the language would appear like mere jargon to those who are not versed in the modern theories of solutions. For instance, the usual test for phosphoric acid is described as follows: "The orthophosphate ion forms with the molybdate ion, MoO_4^- , from ammonium molybdate, in nitric acid solution, a phosphomolybdate ion, which combines with the ammonium ions present to form a canary-yellow precipitate of ammonium phosphomolybdate. . . . This precipitate dissolves in ammonium hydroxide because under these conditions the phosphomolybdate ion is changed to the molybdates and orthophosphate ions." (No formula is given either for the phosphomolybdate ion or the yellow salt.) It may be mentioned that the unsightly spelling of certain chemical words, such as "iodin," "sulfid," and "hydroxid," is used in this book. The number of pages gives a wrong idea of the size of the work, for half the pages left blank for notes are counted.

H. L. W.

7. *The Elements of Qualitative Analysis*; by WM. A. NOYES. 8vo, pp. 101. New York, 1901 (Henry Holt and Co.).—This is the fifth edition of this little book, the first of which appeared in 1887. It is evident from the rapidity with which the editions have appeared that the work is extensively used.

The present issue has been revised and the part dealing with the detection of the acids has been made more systematic. The book contains a concise statement of the ionic theory, with illustrations of its application to qualitative analysis. H. L. W.

8. *Die heterogenen Gleichgewichte vom Standpunkte der Phasenlehre*; von Dr. H. W. BAKHUIS ROOZEBOOM. Vol. I, pp. 216, 8vo. Braunschweig. 1901. (Friedrich Vieweg & Sohn.)—The introduction to this volume is devoted to a discussion of the Gibbs' phase rule with a few general applications to cases of equilibrium. Book I deals very systematically and thoroughly with equilibrium in systems containing one component. Volumes II and III are to be devoted to systems of two and three components, respectively.

Roozeboom, in 1887, was the first to apply the phase rule to chemistry and since then he has contributed perhaps more than anyone else to our knowledge of chemical equilibrium. The book can be most heartily recommended as giving a thorough presentation of the subject. H. W. F.

9. *Viscosity of Helium*.—Lord Rayleigh found for the viscosity of pure helium, between 15° and 100° , the value $h = 0.681$ and C (Sutherland) $= 72.2$. H. SCHULTZE, who has also worked on the viscosity of argon, has redetermined the viscosity of helium, but regrets that the helium used by him was not perfectly pure. He, therefore, compares his results with that found by Rayleigh for helium not wholly pure. The latter found in this case $h = 0.96$. Schultze finds $h = 1.086$ at 15° . He calls attention to a new and unexplained phenomenon in the transpiration of gases. He often found a difference of over 1 per cent in the results of the measurement of the viscosity of a mixture of gases—such as helium and neon or argon—and these differences arose from a change in direction of the transpiration of the gases through the capillary tube. The author does not agree with O. E. Meyer in attributing the phenomenon to the character of the capillary tubes.—*Ann. der Physik*, No. 10, 1901, pp. 302–314.

J. T.

10. *Air-tight glass stop-cocks*.—All who have worked in subjects requiring high exhaustions have met with difficulty in obtaining air-tight stop-cocks. The most perfectly ground glass stop-cocks will leak after a few hours. This leaking is hastened by the presence of high tension electrical apparatus, and in this case is apparently due to minute paths formed by electrification on the surface of the stop-cock. HERMANN THIELE and MORITZ ECKARDT describes a mercury seal for a stop-cock which prevents to a high degree the leaking of the cock. They also describe a mercury seal which dispenses with a stop-cock.—*Ann. der Physik*, No. 10, 1901, pp. 428–431.

J. T.

11. *Migration of the ions*.—Hittorf has shown the dependence of this migration upon the concentration and the temperature of the solution of the electrolyte. R. GANS investigates the dependence of this migration upon physical conditions and finds

that the relative change in the velocities u and v of the ions follows in the same sense and amount the changes in the pressure. From the change in conductivity and the number denoting the amount of migration, one can calculate the change in the velocity of the ions.—*Ann. der Physik.*, No. 10, 1901, pp. 315-330.

J. T.

12. *Photometry of the Ultra-Violet rays.*—The great intensity of the light electric effects produced by an electric spark, leads H. KREUSLER to experiment with a view to determining whether the phenomenon might not lead to a method in photometry. The electrodes for the spark consisted of aluminum, zinc, and an alloy of equal parts of zinc and cadmium, with addition of 5 per cent of antimony. No constant light was obtained except in the case of aluminum if both electrodes were of the same metal. This constancy was obtained, however, if the negative pole was made of aluminum. The photo-electric cell was that of Warbury, consisting of suitable electrodes in an atmosphere of rarified hydrogen. The measurements were carried out with the object of determining the absorption coefficients of various gases and of water. Although there were evidences of constant errors the method seems a promising one.—*Ann. der Physik.*, No. 10, 1901, pp. 412-423.

J. T.

II. GEOLOGY AND MINERALOGY.

1. *Glaciation in Tierra del Fuego and in the Antarctic.*—In a very interesting account of the Antarctic voyage of the "Belgica" during the years 1897 to 1899, read before the Royal Geographical Society by HENRY ARROWSKI, of the scientific staff of the expedition, some observations are given in regard to the ancient glaciers of Tierra del Fuego, and also of parts of Graham Land and neighboring islands in the Antarctic directly south of Cape Horn. In respect to Tierra del Fuego, the author remarks that well-preserved traces of the former extension of the glaciers were observed at numerous points. The bay of the great glacier is a fine fiord opening into Darwin channel; this fiord is divided into basins by three large transversal moraines. He adds: "The transversal moraines are not the only indications of the ancient extension of the great glacier. They rather mark with great clearness the stages of a rapid retreat of this immense river of ice at the close of the glacial epoch. The sides of the mountains which border the fiord bear *roches moutonnées* at considerable altitudes, and one of the mountains has the characteristic outline of a huge sheep's back surmounted by a small hillock. This latter has sharp ridges, whilst all the rest of the mountain is polished and planed by the erosive action of the ice. I have no doubt that during the glacial epoch it was a nunatak rising above the surface of the inland ice which covered the Darwin mountains, and which certainly reached to this point. It was not merely, therefore, the head of the fiord which was blocked with

ice, but the whole of this immense valley was buried in this outpouring of the inland ice, until only a few of the mountain summits remained above the surface of the icy mantle." Similar observations were made on the neighboring Staten Island.

The author remarks upon the remarkable character of the present Antarctic glaciers in being usually simply ice-caps, forming convex glaciers covered with heavy snow. There are, however, also both ice rivers and cascades, and forms recalling "corrie glaciers" all alike buried beneath a mantle of perpetual snow, and bare ice is nowhere seen. Numerous evidences were observed of the greater extension of glaciers in former times, in the frequent occurrence of *roches moutonnées*, in the moraines and in the distribution of erratic blocks.

Moraines were observed at various points along Belgica strait between Danco Land and the outlying islands. One of these moraines at Cape Reclus, running from northeast to southwest, had a great extent, and it was concluded that the glacier producing this moraine must have had a breadth of 10 miles and a depth of 342 fathoms. Another moraine on Banck island had a height of 65 feet and ran parallel to the strait. There must have been formerly an immense glacier which flowed westward through Belgica strait toward the Pacific ocean. It is suggested that the facts observed indicate that the existing climate of Antarctic lands in 64° south latitude may be to-day much the same as that which prevailed in Tierra del Fuego (54° S. L.) during the ice-age.—*Geogr. J.*, xviii, 353.

2. *The Glaciers of Switzerland in 1900.*—The Sixth Annual Report of the International Commission of Glaciers, edited by S. FINSTERWALDER and E. MURET, gives a summary of the condition of glaciers over the northern hemisphere during the year 1900. In regard to the glaciers of Switzerland, it states that the phase of retreat, characteristic of the years preceding, has still continued. It may be said that in 1900 all the glaciers of Switzerland, with a single exception, were either at a state of minimum or actually receding. The exception is the small glacier of Boveyre in val d'Entremont (Valais), which attained an elongation of 8 meters in 1900, and of 113 meters between 1892 and 1900. Six other glaciers are mentioned as possibly advancing, though the observations need confirmation, but of the remaining seventy-five examined, sixty-one were certainly and fourteen probably retrograding.—*Bibl. Univ.*, xii, 1901.

3. *United States Geological Survey*: CHARLES D. WALCOTT, Director.—Three volumes of the Twenty-first Annual Report have recently been issued. These include Parts I and VI. The former contains the Director's Report already issued in separate form and noticed on page 468 of Vol. XI. With this are included also appendixes, including triangulation, primary traverse and spirit leveling.

Part VI, devoted to the Mineral Resources of the United States for 1899, prepared by David T. Day, is issued in two volumes, of upwards of 600 pages each. The first includes Metallic Products with Coal and Coke; the second Non-Metallic Products. The separate topics are handled as heretofore by different individuals, and a large amount of information is thus put before the public, with great promptness, in regard to the development of the mineral wealth of the country.

4. *Indiana: Department of Geology and Natural Resources.* 25th Annual Report, 1900. W. S. BLATCHLEY, State Geologist.—In addition to the usual annual reports and statistics on oil, gas, coal and building stone, this volume contains articles on Portland Cement, by W. S. Blatchley, and Hydraulic Limestone of South-eastern Indiana, by C. E. Siebenthal. The paper on The Lakes of Northern Indiana and their associated Marl Deposits, by W. S. Blatchley and Geo. H. Ashley (pp. 31-322), takes up the question of the origin of the lakes and of the marl and gives maps and detailed descriptions with analyses of over 100 occurrences. 'The original source of the marl material is the glacial clay and it is brought into the lakes by subaqueous springs and is deposited because of the loss of carbondioxide. This loss is caused either by increase in temperature or decrease in pressure or by the action of aquatic plants.' This conclusion is not in accord with the results obtained by C. A. Davis from a study of the Michigan lakes (Jour. of Geol., Sept.-Oct., 1900, and Sept.-Oct., 1901), in which plants "alone have produced a very large part of the marl." In this volume (pp. 530-758 + 31 plates) Dr. E. M. Kindle publishes his final paper on the Devonian Fossils and Stratigraphy of Indiana.

H. E. G.

5. *Geological Survey of New Jersey, Annual Report, 1900.* Trenton.—This report shows progress in all divisions of the state work. One-sixth of the field work for the new topographic map (2000 ft. to the inch) is now done; a new series of geological maps is planned; the study of the Paleozoic formation was continued: much new data was collected on artesian wells, forestry, drainage of swamps, etc. The report includes the following papers: A Preliminary Report on the Palaeozoic Formations, by Stuart Weller (pp. 1-8); Report on Portland Cement Industry, by H. B. Kimmel (pp. 9-101); Artesian Wells, by Lewis Woolman (pp. 103-171); Mineralogical Notes, by Albert H. Chester (pp. 173-188); Chlorine in the Natural Waters of the State, by Wm. S. Myers (pp. 189-196); the Mining Industry, by H. B. Kimmel (pp. 197-213).

H. E. G.

6. *Ice Ramparts*; by E. R. BUCKLEY, Ph.D., with a discussion by Professor C. R. Van Hise. Trans. Wis. Acad. of Sciences, Arts and Letters, vol. xiii, pp. 141-162 with 17 plates.—Dr. Buckley has made a study of the behavior of expanding and contracting ice and the resulting deformation of the ice and of the shore. The facts collected are of interest in themselves, but as Professor Van Hise points out, their greatest value lies in the

fact that the phenomena "reproduce on a larger scale than has been possible by experiment in the laboratory, many of the phenomena of crustal deformation." "The analogies are so astonishingly close as to lead to the conclusion that in most cases crustal forces have acted in a similar manner to those in which the forces in the ice have acted."

H. E. G.

7. *Syllabus of a Course of Lectures on Elementary Geology*; by JOHN C. BRANNER, Ph.D. Stanford University Press, 1898. Pp. 301. *Syllabus of a Course of Lectures on Economic Geology*; by JOHN C. BRANNER and JOHN F. NEWSOM. Stanford University, 1900. Pp. 346.—These publications are useful additions to a geologist's teaching outfit, and are adapted to the uses of students while in college and afterward. These books may well be recommended to general readers who wish a guide in geological reading. The outlines are full, the illustrations clear and abundant, and the bibliography is well chosen for the purpose in view.

H. E. G.

8. *The Loess of Iowa City and Vicinity*; by B. SHIMEK, C.E. Bull. Laboratories of Nat. Hist., University of Iowa, vol. v, No. 2, pp. 195-212.—From a study of the fossil shells found in the loess, Mr. Shimek concludes that "bodies of water did not exist where loess is now found." "The molluscan fauna of the loess points to comparatively dry upland terrestrial conditions such as exist over the greater part of Iowa to-day."

H. E. G.

9. *The River System of Connecticut*; by WILLIAM HERBERT HOBBS. Jour. Geol., Sept.-Oct., 1901.—The location of Connecticut rivers is explained by Professor Hobbs as the result of faulting.

H. E. G.

10. *The Sivamalai Series of Eleolite-Syenites and Corundum-Syenites in the Coimbatore Distr., Madras Presidency*; by THOS. H. HOLLAND. Mem. Geol. Surv. India, vol. xxx, pt. 3, pp. 169-220, 1901.—Eleolite-syenite forms the main mass of a large hill in the district mentioned. It is gneissoid, having a well-marked foliation, generally in conformity to the enclosing gneisses. There are several varieties of the rock, the most prevalent being an even gray one consisting of 34 per cent eleolite, 56 of microperthite feldspar, 3.6 of magnetite and 6.4 of biotite, plagioclase, graphite, etc. An analysis by T. L. Walker gave

SiO ₂	Al ₂ O ₃	Fe ₃ O ₄	MgO	CaO	Na ₂ O	K ₂ O	C	Ign.
55.68	23.81	4.84	0.65	1.69	9.23	5.16	0.58	0.34=101.98

The chief point of interest lies in the presence of the graphite, distributed in thin scales. It shows on heating, after treatment with nitric acid, the phenomenon of "sprouting" which has been held by Moissan to be characteristic of graphite crystallized from fusion. Not only is the graphite in the main rock type but also in coarse-grained "contemporaneous veins" and in black basic lenses or dike-like bands.

As the occurrence of graphite as a well-defined constituent of a rock which has been held heretofore to be of purely igneous

origin is a novel phenomenon of great interest, the author has studied with care the field relations of the rock mass. There is, however, no direct evidence to be obtained from the exposures as to its intrusive nature. So far as can be made out, it occurs as lenticular masses in the schists. There are many points, however, to be seen in the field which are characteristic of igneous masses, and balancing all the evidence obtainable the writer feels it to be distinctly in favor of considering the rock masses eruptive in origin. The foliated structure is thought to have been imposed before complete consolidation. Agreeing with this view, we are now forced to recognize graphite as a new and possible constituent of igneous rocks, which may give rise to new types on occasion.

The corundum occurs in a feldspathic rock associated with the eleolite-syenite. Some varieties contain a red garnet, others chrysoberyl. This syenite is found with the eleolite-syenite in such a way that its exact relations cannot be definitely told, but it is held to be a differentiated product of the same magma. There is thus a remarkable analogy with the occurrence in Hastings County, Ontario.*

L. V. P.

11. *On a Peculiar Form of altered Peridotite*; by T. H. HOLLAND. Mem. Geol. Surv. India, vol. xxxiv, pt. 1, pp. 1-9, 1901.—The author describes a rock mass at Huliya, Mysore State, India, consisting of a matrix of interlaced colorless talc and pale green picrolite (columnar serpentine) with numerous granules of a rhombohedral carbonate and magnetite dust in which lie well-formed, porphyritic crystals of dark gray breunnerite, from one-half to one inch across; they form 35 per cent of the rock. From its staining with iron oxide the rock appears like a diabase with porphyritic pyroxenes or hornblendes. The matrix and breunnerites were analyzed separately, and combining the analyses the rock is found to have the composition

SiO ₂	Fe ₂ O ₄	MgO	CO ₂	H ₂ O
27.3	12.7	35.0	20.0	5.0 = 100.0

From this it is assumed that the rock was a dunite which has been changed by the action of water and carbonic acid. L. V. P.

12. *Perknite*.—This name has been proposed by H. W. TURNER for the dark-colored, heavy, basic, holocrystalline igneous rocks composed of monoclinic amphibole or pyroxene or both. In addition to these chief components, rhombic pyroxene, olivine or feldspar may occur as secondary ones and there may be accessory biotite, iron ore, etc. These rocks have hitherto been called pyroxenite or amphibolite or hornblendite, but they have not

*The occurrence of graphite as a well-marked constituent of an igneous rock is a matter of great interest and importance. It will be correlated with the diamonds in the peridotites of South Africa and in certain meteorites and throws new light on its occurrence in pegmatite dikes described from Canada. If it can be definitely shown by sufficient evidence that carbon is a constituent of the deep-seated magmas, certain vexed questions in geology may be susceptible of a better explanation than any yet offered. L. V. P.

been grouped under one name, as here proposed.—*Jour. Geol.*, vol. ix, pp. 507–511, 1901.

L. V. P.

13. *Outline of Elementary Lithology*; by GEO. H. BARTON. Pp. 112, 12mo. (Boston, 1900.)—This little work is a digest of the main features of the subject of Lithology. The important rock-making minerals and their properties, the names, textures, and classification of rocks, are given in synoptical form. It will be found useful by students reviewing a lecture course on this subject.

L. V. P.

14. *Synchisite and Molybdophyllite*.—A recent number (No. 9) of the Bulletin of the Geological Institution of the University of Upsala contains a mineralogical paper by G. Flink with notes on several known species and also descriptions of the new species, synchisite and molybdophyllite.

SYNCHISITE, from Nararsuk in southern Greenland, was earlier described by G. Nordenskiöld as parisite. It is now found, however, to be distinct. The crystallization is rhombohedral instead of hexagonal and it shows no distinct cleavage. Crystals have commonly the form of acute rhombohedrons. The hardness is 4.5; specific gravity 3.902; color wax-yellow. The composition $\text{CeFCaC}_2\text{O}_6$ is deduced from analyses, the most recent of which (by Mauzelius) is as follows:

CO_2	ThO_2	Ce_2O_3	$(\text{LaDi})_2\text{O}_2$	Y_2O_3	Fe_2O_3	CaO	F	H_2O
25.99	0.30	21.98	28.67	1.18	0.11	16.63	5.04	2.10=102.00

MOLYBDOPHYLLITE is a new lead silicate from Långban, Sweden. It occurs in irregular foliated masses, resembling mica, imbedded in granular limestone; crystallization hexagonal; cleavage basal perfect. The hardness is 3 to 4; specific gravity 4.717. It is colorless with pearly luster on the cleavage face, elsewhere glassy. The composition $\text{R}_2\text{SiO}_4 + \text{H}_2\text{O}$ is given by the analysis:

SiO_2	PbO	MgO	Al_2O_3	Na_2O	K_2O	H_2O
18.15	61.09	11.71	0.46	0.82	0.69	6.32=99.24

15. *Crystallization of Stannite*.—L. J. SPENCER shows that stannite crystallizes not in the tetrahedral group of the isometric system as has been assumed, but in the scalenohedral group of the tetragonal system, as early suggested by Haidinger. Crystals from Bolivia are very near chalcopyrite in occurring forms and in angles, and like it are often pseudo-cubic from twinning.—*Min. Mag.*, xiii, 54.

16. *Conchite and Ktypteite*.—H. VATER shows that the supposed new form of calcium carbonate, called conchite (p. 84) by Agnes Kelly, is in fact not distinct from aragonite. The ktypteite of Lacroix is probably also identical with the same mineral.—*Zeitschr. f. Kryst.*, xxxv, 149.

17. *The Meteorite of Felix, Perry County, Alabama*.—An account has recently been given by G. P. MERRILL of the stony meteorite which fell near Felix, Alabama, on May 15, 1900.

The explosion of the original meteor yielded three pieces; of these, the main mass recovered weighed about 7 pounds; a second small piece was found but lost and a third has not been found. The material of the meteorite is soft and friable, resembling somewhat the stones of Warrenton, Missouri, and Lancé, France, though darker than the former and more chondritic than the latter. It consists essentially of the minerals olivine, augite, and enstatite, with troilite and native iron, the silicates occurring in the form of chondrules, or associated more or less fragmental particles, embedded in a dark, opaque, or faintly translucent base, which is irresolvable so far as the microscope is concerned. The non-metallic portion (including troilite and chromite) made up 97 per cent of the whole and nickeliferous iron only 3 per cent. The dark color of the stone is attributed to carbon distributed as minute flakes of graphite.—*Proc. U. S. Nat. Museum*, xxiv, 192.

III. ZOOLOGY.

1. *Note on the Nomenclature of Bermuda Birds*.—Mr. A. HYATT VERRILL published a short paper on the Bermuda avifauna in this Journal for July, 1901 (issued the last of June). He also printed a more detailed article in "The Osprey," v, pp. 83-85, for June, 1901, with figures of the three following species and of the Tropic Bird, photographed from life. In these articles he described the Bermuda Cardinal Bird and the Blue Bird as new sub-species, peculiar to Bermuda. The Cardinal Bird he named *Cardinalis cardinalis Somersii*; the Blue Bird, *Sialia sialis Bermudensis*; the Ground Dove, *Columbigallina passerina Bahamensis*.

Outram Bangs and Thos. S. Bradlee also published a paper on the Birds of Bermuda in "The Auk" for July, 1901, pp. 249-257, in which new names are given to two of these birds and two others, which they call new species.

They name the Ground Dove, *Columbigallina bermudiana*; the White-eyed Vireo, *Vireo bermudianus*; the Catbird, *Galeoscoptes bermudianus*; the Cardinal, *Cardinalis bermudianus*. Mr. Verrill's article in this Journal appears to have been published a few days earlier than the latter.

To me it seems quite useless to regard these very slightly differentiated forms as distinct "species." The differences noted in the Ground Dove, Catbird, and Vireo, are trivial and scarcely sufficient to constitute *varieties*. To consider them as "sub-species" is certainly a sufficient strain on the much-stretched meaning of the term "sub-species." I should at most call these mere local varieties, scarcely differentiated.

In respect to the Ground Dove, there are reasons for believing that it was introduced to Bermuda from the Bahamas, since the settlement of the islands, like many other things. None of the earlier writers mentioned it in the lists of birds that they gave.

This would hardly have been the case had it been present, for it is exceedingly tame and familiar.

Mr. A. K. Fisher, in *Bird Lore*, Oct., 1901, p. 178, states that the original *Motacilla sialis* Linné, ed. x, p. 187, was from Bermuda. This is not correct. Linné gave it as from "Bermudis & America calidore." He also quoted Catesby, *Hist. Carolina*, etc., p. 47, pl. 47, 1731. Catesby says that he had seen it in "Carolina, Virginia, Maryland, and the Bermudas." But he states in his preface that his birds were mostly drawn in Carolina and Georgia, where he spent several years in drawing them. A few were drawn in the Bahamas, where he spent about a year, mostly on the fishes and plants. He does not say that he made *any* drawings in Bermuda, where he probably made a mere passing visit. The Bluebird does not occur in the Bahamas. His figure clearly represents the common North American variety.

A. E. V.

2. *Reports on the Fauna of Porto Rico*.—As a result of the scientific expedition to Porto Rico on the Steamer "Fish Hawk," 1898-99, the United States Fish Commission has published, in its Bulletin for 1900, several valuable reports on the fauna of the island.

The largest and most fully illustrated is the Report on the Fishes and Fisheries, by Everman and Marsh, 1900, (350 pages, 49 colored plates, and a map). In this report 291 species of fishes are included. The plates are excellent. They were drawn and colored from life by A. H. Baldwin and C. B. Hudson. It forms an excellent manual for any part of the West Indian region.

The Report on the Brachyura and Macrura, by Miss M. J. Rathbun (137 pages, 2 colored plates) is also a very complete report on these Crustacea. It contains descriptions of all the genera and species, with analytical tables, and will serve as a standard manual.

The Report on the Anomura, by J. E. Benedict (17 pages, 4 plates) is of the same excellent character.

Mr. R. P. Bigelow has reported on the Stomatopoda (10 pages, with cuts).

Mr. H. F. Moore has prepared the Report on the Isopoda (14 pages, with cuts, and 5 plates), and Mr. M. A. Bigelow, a very short Report on the Cirripedia, which were evidently much neglected.

The Report on the Echinoderms is by Professor H. L. Clark (33 pages, 3 plates). It is fairly complete for the shallow water forms, though many common West Indian starfishes and ophiuroids are lacking.

The Report on the Annelids, by A. L. Treadwell (27 pages, with cuts) contains a considerable number of new species, but is evidently based on a very incomplete collection.

Mr. W. R. Coe has also contributed a short report on the very few nemerteans that were obtained.

J. P. Moore has described two new leeches.

We understand that several other reports, on other groups, are soon to be printed. A. E. V.

3. *Papers from the Alaska Harriman Expedition*.—Several useful and valuable reports on the collections obtained by the Harriman expedition have already been printed by the Washington Academy of Sciences.

The Report on the Nemerteans, by W. R. COE (March, 1901, 84 pages, with cuts and 13 plates, 6 colored), is, perhaps, the most important and complete of those hitherto published. It relates to a group that is very richly developed on the Alaskan coast, and which has hitherto been almost entirely neglected in those waters. It includes 32 species, of which 28 are new. The colored figures are excellent. A. E. V.

4. *Zoölogy: An Elementary Text Book*; by A. E. SHIPLEY and E. W. MACBRIDE. London and New York, 1901 (The Macmillan Co.). 8vo, 632 pages, 347 cuts.—Although called "elementary" this is a rather complete text-book, suitable for the more advanced students in colleges and universities, or for a reference book. The treatment of the subjects is clear and the illustrations are generally excellent. The Vertebrata (or Chordata) occupy an unusually large part (nearly half, or 286 pages) of the book, which will probably be considered an advantage by many instructors. But it compels a severe cutting down of the space for some of the important groups of Invertebrata. Thus the great group of hexapod insects occupies only 23 pages, and the Mollusca 39 pages.

It is an excellent addition to the list of recent text-books and manuals of zoölogy. A. E. V.

5. *An Elementary Course of Practical Zoölogy*; by T. JEFFREY PARKER and W. N. PARKER. London and New York (The Macmillan Co.). Small 8vo, 608 pages, 156 cuts.—This is intended mainly as a laboratory guide for a course in "biology" or comparative anatomy, such as is commonly given in many of our colleges and scientific schools. For this purpose it seems to be admirably adapted, being more up to date than most of the similar works now in use. About one-third the book (215 pages) is devoted to the study of the frog, in detail. The balance is devoted to various other typical forms, such as the amœba, hydra, earthworm, crayfish, mussel, amphioxus, dogfish, rabbit. About 60 pages, at the end, are devoted to cell structure and embryology. A. E. V.

IV. MISCELLANEOUS SCIENTIFIC INTELLIGENCE.

1. *National Academy of Sciences*.—The following is a list of the papers entered to be read before the National Academy at the meeting in Philadelphia, held Nov. 12-14.

GEORGE F. BECKER: Note on linear force exerted by growing crystals. Note on the orogenic theory of tilted blocks.

- HORATIO C. WOOD, JR.: On the vaso-motor supply of the lungs.
- GEORGE F. BARKER: Biographical memoir of Frederick Augustus Genth. The monatomic gases. The newer forms of incandescent electric lamps.
- JAMES M. CRAFTS: On the pseudo-catalytic action of concentrated acids.
- SAMUEL L. PENFIELD: On the use of the stereographic projection in making accurate maps; with criticism of some recent methods of map projection. The tendency of complex chemical radicals to control crystallization because of their mass effect; a study in isomorphism.
- CHARLES S. PEIRCE: On the logic of research into ancient history.
- EDGAR F. SMITH: Observations on tungsten.
- S. WEIR MITCHELL and SIMON FLEXNER: Snake venom in relation to hæmolytic, bacteriolysis and toxicity.
- IRA REMSEN: On the nature of the double halides.
- CYRUS B. COMSTOCK: Biographical memoir of General John Newton.
- HENRY F. OSBORN: Dolichocephaly and Brachycephaly as the dominant factors in cranial evolution. Cranial evolution of Titanotherium II. Latent or potential homology.
- EDWARD W. MORLEY and CHARLES F. BRUSH: A new gauge for the direct measurement of small pressures. Transmission of heat through vapor of water at small pressures.
- CARL BARUS: On quadrant electrometry with a free light needle highly charged through a conductor of ionized air. On nuclear condensation in the vapor of non-electrolytes like benzene; and on graded condensation.
- HENRY L. BOWDITCH: The work of the International Association of Academies.
- CASWELL GRAVE: A method of rearing marine larvæ.

2. *Annual Report of the Board of Regents of the Smithsonian Institution, for the year ending June 30, 1900.* Pp. xlv, 759. Washington, 1901.—The Annual Report of the Smithsonian Institution, recently published, includes in its preliminary part the Report of the Secretary, Professor S. P. Langley, which was issued earlier in separate form, and has been noticed on page 400 of the May number. The remainder of the volume is occupied with the general Appendix, which contains reprints of a well-selected series of papers, on topics ranging from astronomy to medicine, and all calculated to be of great interest to the ordinary reader as well as to the scientist. With its other important functions, the Smithsonian Institution does a valuable work in thus presenting to the public well-digested reviews of the progress of science in its different departments and also in republishing articles which would not otherwise be readily accessible. Of the subjects here included, one of particular interest is an account, liberally illustrated, of the Langley Aërodrome, and another on the Zepelin Air Ship accompanies it. A complete list of the papers printed in the volume would be required to show their range of subject and individual importance.

3. *The Smithsonian Institution: Documents relative to its Origin and History, 1835-1899*; compiled and edited by WILLIAM JONES RHEES, in two volumes. Vol. I, 1835-1887. Twenty-fourth Congress to Forty-ninth Congress. Pp. liii, 1044. Washington, 1901.—The very interesting volumes relating to the history and work of the Smithsonian Institution, presented to the public some years since (1879, 1896) are now followed by the republication in full of all the public documents which relate to

its inception and history. The volume now issued covers the period from 1835 to 1887.

4. *Beiträge zur Chemischen Physiologie und Pathologie*—Zeitschrift für die gesamte Biochemie; herausgegeben von Franz Hofmeister, o. Professor der physiologischen Chemie an der Universität Strassburg. Braunschweig. (Fr. Vieweg und Sohn. Two volumes per year; price 15 marks for each volume of 12 numbers.)—The progress of recent years in various branches of biology and medical science has been particularly characterized by the growing interest in the chemical problems involved, and the increased application of chemical methods for their solution. The rapid development of physiological chemistry is indicated by the beginning of a new journal devoted to original investigations of bio-chemical nature. In addition to the presentation of more exhaustive contributions, it is proposed to afford a medium for the speedy publication of briefer communications regarding new discoveries, etc. Under the editorship of one of the most active workers in this field, a successful future for the new publication is assured; and the scientific papers printed in the three numbers already published give evidence that the "Beiträge" will form a part of the permanent literature of biology.

Contributions may be directed to the editor, Wimpfelingstrasse, 2, Strassburg i. E. L. B. M.

5. *Annals of Harvard College Observatory*.—Recent publications include the following:

Vol. XXVIII, Pt. II; Spectra of Bright Southern Stars; Photographed with a 13-inch Boyden Telescope, as a part of the Henry Draper Memorial, and discussed by ANNIE J. CANNON, under the direction of EDWARD C. PICKERING, Director of the Observatory. Pp. 131-263, with three plates.

Vol. XLI, No. VII. Comparison of Results obtained with different forms of Apparatus in Meridian Observations; by Arthur Searle. Pp. 189-211.

6. *Royal Society of London*.—The Copley Medal has recently been awarded by the Royal Society to Professor J. Willard Gibbs of Yale University, New Haven, for his contributions to mathematical physics.

OBITUARY.

RUDOLPH KOENIG, the well-known investigator in acoustics and skillful maker of acoustical apparatus, died at Paris on October 2, at the age of sixty-eight years.

PROFESSOR A. F. W. SCHIMPFER, the eminent botanist, died on September 9 in his forty-sixth year.

INDEX TO VOLUME XII.*

A

- Academy of Sciences, National, meeting at Philadelphia, 472.
 Adams, E. P., electro-magnetic effects of moving charged spheres, 155.
 Adams, G. I., Carboniferous and Permian age of the Red Beds of Oklahoma, 383.
 Air, separation of least volatile gases in, Liveing and Dewar, 207.
 Air-tight glass stop-cocks, Thiele and Eckardt, 463.
 Alaska, Harriman Expedition, 472.
 Almy, J. E., discharge-current from a surface of large curvature, 175.
 Alternating current discharge, spectrum, Wright and Downs, 66.
 American Philosophical Society, 400.
 Argentine Republic, Meteorological Atlas, Delachaux, 88.
 Argon, viscosity, Schultze, 76.
 Arkansas, Geol. Survey, vol. v, 78.
 Association, American, meeting at Denver, 174, 323.
 — British, meeting at Glasgow, 324.

B

- Bailey, E. H. S., Laboratory Guide to Qualitative Analysis, 462.
 Barton, G. H., Elementary Lithology, 469.
 Barus, C., on temporary set, 247; effect of temperature and moisture on the emanation of phosphorus, 327.
 Beecher, C. E., Cambrian fossils of St. François Co., Missouri, 362; Eurypterid remains in the Cambrian of Missouri, 364.
 Bermuda, additions to the Avifauna, Verrill, 64; nomenclature of birds of, Verrill, 470.
 — death of fishes at, in 1901, Verrill, 88.
 Birds of Bermudas, Verrill, 64; nomenclature, Verrill, 470.

Bolton, H. C., Chemical Bibliography, 89.

BOTANY.

- African plants collected by Dr. Welwitsch in 1853-61, catalogue, 324.
 Cocos nucifera, anatomy of, Winton, 265.
 Milchsaff und Schleimsaff der Pflanzen, Molisch, 87.
 Brazil, manganese deposits of Minas Geraes, Derby, 18.
 British Museum catalogues, 89.
 Browning, P. E., estimation of caesium and rubidium, 301.

C

- Cady, H. P., Laboratory Guide to Qualitative Analysis, 462.
 Canada Geol. Survey, Annual Report, 79, 394.
 Canadian Paleozoic corals, revision of the genera, Lambe, 79.
 Cathode rays, Seitz, 389.
 Chemical Analysis, Qualitative, Perkin, 76; Bailey and Cady, 462.
 Chemischen Physiologie und Pathologie, Beiträge zur, Hofmeister, 474.
 Chemistry, Bibliography of, Bolton, 89.

CHEMISTRY.

- Acetylene, heat of dissociation and combustion of, Mixer, 347.
 Acid nitrates, Wells and Metzger, 460.
 — solutions, methods of standardizing, Hopkins, 461.
 Alloys, Thermochemistry of, Baker, 460.
 Ammonium, existence of, Ruff, 387.
 — cyanate, Walker and Wood, 75.
 Aniline and analogous bases, Sabatier and Senderens, 387.

* This Index contains the general heads, BOTANY, CHEMISTRY (incl. chem. physics), GEOLOGY, MINERALS, OBITUARY, ROCKS, and under each the titles of Articles referring thereto are mentioned.

CHEMISTRY.

- Antimony pentachloride, double compounds of, Rosenheim and Stellman, 460.
 — salt of quadrivalent, Wells and Metzger, 389.
 Cæsium and rubidium, etc., estimation of, Browning, 301.
 — and thorium, double chlorides, Wells and Willis, 191.
 Cæsium-tellurium fluoride, Wells and Willis, 190.
 Calcium, strontium and barium, estimation, Peters, 216.
 Carolinium, a new element, 462.
 Caro's acid, composition of, Baeyer and Villiger, 73.
 Europium, a new element, Demargay, 321.
 Gooch-crucible, modified, Heraeus, 388.
 Hydrogen, see **Hydrogen**.
 Lead, radio-active, Hofmann and Strauss, 388.
 Molybdic acid, estimation of, reduced by hydriodic acid, Gooch and Pulman, 449.
 Persulphates, determination of, Peters and Moody, 367.
 Phosphorus, emanation from, Barus, 327.
 — ignition temperature, Eydman, 73.
 Quantitative analysis, new method of, Thatcher, 320.
 Quartz, vitrified, Shenstone, 74.
 Radium, radio-activity produced by salts of, Curie and Debierne, 319.
 Selenium in sulphuric acid, Jouve, 75.
 Sodium thiosulphate, action on solutions of metallic salts, Norton, 115.
 Supersaturated solutions, influence of magnetism, de Hemptinne, 75.
 Tellurium, gravimetric determination, Gutbier, 389.
 Thorium, new element associated with, Baskerville, 462.
Clerke, A. M., Unsolved Problems of Low Temperature Research, 393.
Colorado Valley, geology of the Little, Ward, 401.
Connecticut, river system of, Hobbs, 467.
Copper voltmeter, new solution for, Shepherd, 49.
Cosmogony, mathematical notes to rival theories of, Fisher, 140.
Cuba, bituminous deposits, Peckham, 33.

D

- Davis, B.**, behavior of small closed cylinders in organ-pipes, 185; locating nodes and loops of sound in the open air, 263.
Davis, J. W., motion of compressible fluids, 107.
Derby, O. A., manganese deposits of Minas Geraes, Brazil, 18.
Dewar, J., the nadir of temperature and allied problems, 168; separation of the least volatile gases of atmospheric air, 207.
Dielectric constant of paraffins, Hormell, 433.
Downs, E. S., spectrum of alternating current discharge, 66.
Duff, A. W., secondary undulations shown by tide-gauges, 123.

E

- Earthquake** investigation committee, publications, 90.
Electric arc, resistance and electromotive force, Duddell, 392.
 — convection, magnetic effect of, Adams, 155; Pender, 173; Wilson, 322.
 — discharge-current from surface of large curvature, Almy, 175.
 — flow in gases, Stark, 77.
 — resistance, experiments on high, Rood, 91.
Electro-Magnetic Phenomena, Treatise, Lyons, 77.
Electromotive force of the Clark and the Weston-cell, Jaeger and Lindeck, 76.
Ether and gravitational matter through infinite space, Kelvin, 390.
Ethnology, publications of Bureau of American, 89.

F

- Fauna** of Porto Rico, reports, 471.
Field Columbian Museum, publications, 89.
Fisher, O., mathematical notes to rival theories of Cosmogony, 140.
Fluids, motion of compressible, Davis, 107.
Ford, W. E., calaverite, 225.

G

- Galvanometers** of high sensibility, Mendenhall and Waidner, 249.
Gases of atmospheric air, separation of the least volatile, Liveing and Dewar, 207.

GEOLOGICAL REPORTS.

- Arkansas, vol. v, 78.
 Canada, 79, 394.
 Indiana, 466.
 Iowa, vol. xi, 396.
 Maryland, 77.
 Minnesota, vol. vi, 395.
 New Jersey, 466.
 United States, 21st Annual Report, 465.

- Geology**, lectures on Economic, Bran-
 ner and Newsom, 467.
 — lectures on Elementary, Bran-
 ner, 467.

GEOLOGY.

- Amygdaloidal melaphyre of the
 Boston Basin, Burr, 79.
 Bituminous deposits of Cuba,
 Peckham, 33.
 Cambrian fossils of Missouri,
 Beecher, 362.
 Carboniferous and Permian age of
 the Red Beds of Oklahoma,
 Adams, 383.
 — terranes, time values of provin-
 cial, Keyes, 305.
 Crinoid from the Hamilton of
 Charlestown, Ind., new, Wood,
 297.
 Dragons of the Air, Seeley, 396.
 Eocene deposits of Maryland, Clark
 and Martin, 77.
 — Mammalia in the Marsh collec-
 tion, studies, Wortman, 143, 193,
 281, 377, 421.
 Etinde, volcano of the Cameroon
 Mts., Africa, Esch, 81.
 Eurypterid remains in the Missouri
 Cambrian, Beecher, 364.
 Glaciers, see **Glaciers**.
 Helgeland, geology, Vogt, 82.
 Ice ramparts, Buckley, 466.
 Igneous rocks, classification, von
 Federov, 83.
 Laccoliths of Highwood Mts. Mon-
 tana, geology of, Weed and Pir-
 sson, 1.
 Limestones of Missouri, age and
 geological relations, Nason, 358.
 Little Colorado valley, geology,
 Ward, 401.
 Loess of Iowa City and vicinity,
 Shimek, 467.
 Manganese deposits of Minas Ge-
 raes, Brazil, Derby, 18.
 Paleozoic corals, Canadian, Lambe,
 79.
 River system of Connecticut,
 Hobbs, 467.

- Vesuvius, explosive activity of,
 during April and May, 1900,
 Matteucci, 81.
Gibbs, J. Willard, receives Copley
 medal, 474.
Glaciers, ancient, in Tierra del Fuego
 and Antarctic, 464.
 — in Switzerland in 1900, 465.
Goldschmidt, V., Harmonie und
 Complication, 325.
Gooch, F. A., Research Papers from
 the Kent Chemical Laboratory,
 Yale Univ., 321; molybdc acid
 reduced by hydriodic acid, 449.
Gooch-crucible, modified, Heraeus,
 388.
Gray, E., Nature's Miracles, 325.

H

- Harmonie und Complication, Gold-
 schmidt, 325.
 Harvard College Observatory, An-
 nals, 474.
 Helgeland, geology, Vogt, 82.
 Helium, viscosity of, Schultze, 463.
Hoffmann, G. C., mineral occur-
 rences in Canada, 447.
Hormell, W. G., dielectric constant
 of paraffins, 433.
Hydrogen, conductivity by nega-
 tively charged ions, Townsend and
 Kirkby, 76.
 — diffusion through palladium, Win-
 kelmann, 389.
 — spectra of, Trowbridge, 310.

I

- Indiana Geol. Survey, 25th Annual
 Report, 466.
Ions, conductivity produced in hy-
 drogen, etc., by the motion of nega-
 tively charged, Townsend and
 Kirkby, 76.
 — migration of, Gans, 463.
 Iowa Geol. Survey, vol. xi, 396.

K

- Kelvin, dynamical theory of light
 and heat, 391; ether and gravita-
 tional matter in space, 390.
 Kent Chemical Laboratory, Research
 papers from, Yale University,
 Gooch, 321.
Keyes, C. R., time values of provin-
 cial Carboniferous terranes, 305.

L

- Light and heat, dynamical theory of,
 Kelvin, 391.

- Lithology, Outline of Elementary, Barton, 469.
 Liveing, G. D., separation of the least volatile gases of atmospheric air, 207.
 Lloyd, M. G., magnetic effects in tellurium, 57.
 Low Temperature Research, Unsolved Problems, Clerke, 393.
 Lyons, T. A., Treatise of Electro-Magnetic Phenomena, 77.

M

- Magnetic effects of moving electric charges, Adams, 155; Pender, 173; Wilson, 322.
 Marine invertebrates of Eastern Canada, Catalogue, Whiteaves, 395.
 Marsh collection, Peabody Museum, Eocene mammalia of, Wortman, 143, 193, 281, 377, 421.
 Maryland, Eocene deposits, Clark and Martin, 77.
 McNairn, W. H., phlogopite crystals from Ontario, 393.
 Mendenhall, C. E., galvanometers of high sensibility, 249.
 Meteorite, the Veramin, Ward, 453.
 — stony, of Perry, Alabama, 469.
 — swarms. Högbom, 399.
 Meteorites, iron, classification, Cohen, 86.
 Meteorological Atlas of Argentine Republic, Delachaux, 88.
 Mexico, Bulletin of the Geol. Institute, Ordeñez, 84.
 Mineralogie, Handbuch der, Hintze, 399.
 Mineralogy and Petrography at Yale University, Penfield and Pirsson, 398.

MINERALS.

- Atacamite crystals, Chili, 100.
 Barite, Kansas City, Mo., 47.
 Brookite, No. Carolina, 180.
 Calaverite, California, 225. Calcite, 42. Caledonite, Montana, 47.
 Celestite, Salina Co., Kan., 48.
 Cerulite, Chili, 85. Chrysoberyl, New York, 104. Conchite, 84, 469. Corundum, in syenite, Madras, 467.
 Datolite, Quebec, 447.
 Eleolite-syenite, Madras, 467.
 Faujasite, Quebec, 448.
 Galena, 45.
 Hussakite, Brazil, 85.
 Ktypteite, 469.
 Lassallite, France, 85. Leadhillite,

- California, 46. Linarite, California, 46.
 Marcasite, 414. Mercuric iodide, New South Wales, 98. Molybdo-phyllite, Sweden, 469.
 Octahedrite, No. Carolina, 180.
 Pectolite, New Jersey, 99. Phlogopite crystal, Ontario, 398.
 Pyrite, New Jersey, 45; 414.
 Pyroxene, Tennessee, 105.
 Quartz, vitrified, Shenstone, 74.
 Realgar, Washington, 103.
 Seligmannite, Switzerland, 85. Sulvanite, So. Australia, 85. Stan-nite, crystallization, 469. Synchisite, Greenland, 469.
 Termierite, France, 85. Torrens-ite, 85.
 Vesuvianite, New Mexico, 104.
 Viellaurite, 85. Violaite, 86.
 Minnesota, Geol. Survey, vol. vi, 395.
 Missouri, Cambrian limestones, Nason, 358; fossils of, Beecher, 362, 364.
 Mixter, W. G., heat of dissociation and combustion of acetylene, etc., 347.
 Montana, laccoliths of Highwood Mts., Weed and Pirsson, 1.
 Moody, S. E., determination of per-sulphates, 367.
 Moses, A. J., mineralogical notes, 98.

N

- Narkose, Studien über die, Overton, 325.
 Nason, F. L., age and geol. relations of the St. Joseph and Potosi lime-stones of Missouri, 359.
 Nature's Miracles, Gray, 325.
 New Jersey, Geol. Survey, 466,
 Nodes and loops of sound in the open air, method of locating, Davis, 263.
 Norton, J. T., Jr., action of sodium thiosulphate on solutions of metal-lic salts, 115.
 Noyes, W. A., Elements of Qualita-tive Analysis, 462.

O

OBITUARY—

- Lacaze Duthiers, Baron de, 326.
 Le Conte, Joseph, 174, 248.
 Nordenskiöld, Adolf Erik, 326.
 Koenig, Rudolph, 474.
 Schimper, A. F. W., 474.
 Schott, Charles Anthony, 326.
 Schur, Dr. Wilhelm, 326.

Oklahoma, Carboniferous and Permian age of the Red Beds of, Adams, 383.

Organ-pipes, behavior of small closed cylinders in, Davis, 185.

P

Paraffins, dielectric constant of, Hormell, 433.

Peckham, H. E., bituminous deposits of Cuba, 33.

Penfield, S. L., calaverite, 225; Contributions to Mineralogy and Petrography from Sheffield Scientific School, 398.

Perkin, F. M., Qualitative Chemical Analysis, 76.

Peters, C. A., calcium, strontium and barium, estimation of, 216; determination of persulphates, 367.

Phasenlehre, die heterogenen Gleichgewichte vom Standpunkte der, Roozeboom, 463.

Phosphorus, effect of temperature and moisture on the emanation of, Barus, 327.

Photometry of the ultra-violet rays, Kreusler, 463.

Pirsson, L. V., geology of laccoliths in Highwood Mts., Montana, 1; Contributions to Mineralogy and Petrography from Sheffield Scientific School, 398.

Porto Rico, reports on Fauna, 471.

Pulman, O. S., Jr., molybdic acid reduced by hydriodic acid, 449.

Q

Qualitative Analysis, Elements, Noyes, 462.

— — Laboratory Guide to, Bailey and Cady, 462.

R

Radio-activity produced by salts of radium, Curie and Debierne, 319.

— of lead, Hofmann and Strauss, 388.

Resistance, effect on, of amalgamated gases, Rollins, 322.

Rhees, W. J., Origin and History of the Smithsonian Institution, 473.

Robinson, H. H., octahedrite and brookite from No. Carolina, 180.

ROCKS.

Corundum-syenite and eleolite-syenite containing graphite, Madras, Holland, 467.

Igneous rocks, classification, von Federov, 83.

— of Cameroon Mts., Esch, 81.

Laccoliths of Highwood Mts., Montana, Weed and Pirsson, 1.

Kedabekite, 247.

Kenyte, 247.

Melaphyre of Boston Basin, Burr, 79.

Peridotite, altered, 468.

Perknite, Turner, 468.

Rogers, A. F., mineralogical notes, 42.

Rollins, W., effect of amalgamated gases on resistance, 322.

Rood, O. N., experiments on high electrical resistance, part II, 91.

Roozeboom, H. W. B., die heterogenen Gleichgewichte vom Standpunkte der Phasenlehre, 463.

Royal Society, Copley medal, 474.

S

Scientia, Bohn, 89.

Secondary undulations shown by tide-gauges, Duff, 123.

Seeley, H. G., Dragons of the Air, 396.

Shepherd, W. K., new solution for copper voltameter, 49.

Smithsonian Institution, Annual Report, 473; Origin and History, 1835-1899, vol. i, Rhees, 473.

Sound, experiments in, Davis, 185, 263.

Spectra, infra-red, of the alkali-metals, photography, Lehman, 390.

Spectrum of the alternating current discharge, Wright and Downs, 66.

Stokes, H. N., pyrite and marcasite, 414.

T

Tellurium, magnetic effects in, Lloyd, 57.

Temperature, the nadir of, and allied problems, Dewar, 168.

— Unsolved Problems of Low, Clerke, 393.

Temporary set, Barus, 247.

Thatcher, R. W., new method of quantitative analysis, 320.

Tide-Gauge observations, Duff, 123.

Trowbridge, J., spectra of hydrogen, 310.

U

United States Geol. Survey, 21st Annual Report, 465.

— — Naval Observatory, publications, 90.

V

- Verrill, A. E., death of fishes at Bermuda in 1901, 88.
 Verrill, A. H., additions to the Avifauna of the Bermudas, 64; nomenclature of Bermuda birds, 470.
 Vesuvius, explosive activity in April, May, 1900, Matteucci, 81.

W

- Waidner, C. W., galvanometers of high sensibility, 249.
 Ward, H. A., Veramin meteorite, 453.
 Ward, L. F., geology of the Little Colorado Valley, 401.
 Weed, W. H., geology of laccoliths in Highwood Mts., Montana, 1
 Wells, H. L., caesium-tellurium fluoride, 190; double chlorides of caesium and thorium, 191.
 Willis, J. M., caesium-tellurium fluoride, 190; double chlorides of caesium and thorium, 191.
 Winton, A. L., anatomy of *Cocos nucifera*, 265.

- Wood, E., new Crinoid from the Hamilton of Charlestown, Ind., 297.
 Wortman, J. L., studies of the Eocene Mammalia in the Marsh collection, 143, 193, 281, 377, 421.
 Wright, A. W., spectrum of alternating current discharge, 66.

Y

- Yale Bicentennial publications, 321, 398.

Z

- Zoologisches Addressbuch, 90.
 Zoology, Shipley and MacBride, 472.
 — Practical, Parker and Parker, 472.

ZOOLOGY.

- Avifauna of the Bermudas, additions to, Verrill, 64; nomenclature of, 470.
 Fauna of Porto Rico, 471.
 Fishes, death of, at Bermuda in 1901, Verrill, 88.

VOL. XII.

JULY, 1901.

Established by BENJAMIN SILLIMAN in 1818.

THE
AMERICAN
JOURNAL OF SCIENCE.

EDITOR: EDWARD S. DANA.

ASSOCIATE EDITORS

PROFESSORS GEO. L. GOODALE, JOHN TROWBRIDGE,
W. G. FARLOW AND WM. M. DAVIS, OF CAMBRIDGE,

PROFESSORS A. E. VERRILL, HENRY S. WILLIAMS AND
L. V. PIRSSON, OF NEW HAVEN.

PROFESSOR GEORGE F. BARKER, OF PHILADELPHIA,
PROFESSOR JOSEPH S. AMES, OF BALTIMORE,
MR. J. S. DILLER, OF WASHINGTON.

FOURTH SERIES.

VOL. XII—[WHOLE NUMBER, CLXII.]

No. 67.—JULY, 1901.

NEW HAVEN, CONNECTICUT.

1901.

THE TUTTLE, MOREHOUSE & TAYLOR CO., PRINTERS, 125 TEMPLE STREET.

Published monthly. Six dollars per year. \$6.40 to countries in the Postal Union. Remittances should be made either by money orders, registered letters, or bank checks (preferably on New York banks).

MONTANA.

Several shipments of interesting minerals from Montana have lately been received, a number of the most notable being reviewed below. The great mineral wealth of this district is well-known, and to its present activity is due the increasing number of mineral species reported.

CRYSTALLIZED RHODOCHROSITE. Characteristic rhombohedrons of a rich pink in aggregates, clean cut and perfect. They lack the translucency of the Colorado find, but in other features closely resemble the material from that state. Crystals vary in size from $\frac{1}{4}$ to an inch and more across with corresponding thickness. Occasionally, groups are coated with a white drusy quartz making an association both interesting and attractive. Prices 50c. to \$2.00. Massive 50c. per lb.

CRYSTALLIZED ENARGITE. A few neat groups of the rare copper sulpharsenate, illustrating habit and modifications. Crystallized metallic minerals find quick sale, and it is confidently expected that at our low scale of prices, the best of the lot will be immediately sold. Prices 50c. to \$3.00. Massive 75c. per lb.

AMETHYST. Our correspondent spent several months at the Amethyst locality, and after much difficulty succeeded in securing what are considered the finest specimens as yet found. The types show parallel growth, interesting capping forms and single doubly terminated crystals. Color is good, generally deepening at the tips. Convenient cabinet sizes—50c. to \$4.00.

TOURMALINITIC QUARTZ.

Two shipments of this odd occurrence permit us to describe its varied habits and strange associations. In appearance the crystals are black, due to the fine network of included Tourmaline hairs, which occasionally are widely separated, reminding one of the more common "fêches d'amour." A peculiar "stem" extends beyond the base of some crystals, around which the Quartz seems to have formed. The Tourmaline is often isolated on the "stem," appearing in bristling tufts and masses. The very fact that these specimens differ widely from the usual Quartz forms, makes them attractive to the collector, but aside from this point they combine such interesting features scientifically, that a steady demand is anticipated. Prices 50c. to \$3.50 in 2 and 4 inch sizes.

COVELLITE, CHALCOCITE and BORNITE in pure massive lumps neatly trimmed to cabinet sizes. 50c. to \$1.00 for a typical specimen. Trial orders solicited. Approval consignments submitted.

FOOTE MINERAL CO.,

FORMERLY DR. A. E. FOOTE,

WARREN M. FOOTE, Manager.

ESTABLISHED 1876.

PHILADELPHIA,
1317 Arch Street.

PARIS,
24 Rue du Champ de Mars.

AN OLD COLLECTION.



We shall offer for sale another lot of miscellaneous specimens from an old collection, besides the several hundred advertised last month, which included Roeperite, Bementite, Pa. Amethyst. French Creek Chalcopyrite, Cubic Spinels, Japan Stibnites, Hungarian Opal, Siberian Emeralds and Beryl, Atlasite, Euchroite, Langite, Lettsonite, Serpierite, Connellite, Libethenite, Manganite, Dawsonite, Partzite and extra fine Cumberland Mimetite and Pyromorphite. (Many of these have been sold.)

EXTRA FINE MOLYBDENITE CRYSTALS !

Choice crystals of molybdenite have always been high priced and not at all common. Of the large lot of unusually well defined crystals offered last month, from a new locality in the far west, we have still a good supply. Well formed crystals, one inch to four inches in diameter, with low pyramids of about 40 and 55 degrees, 10c. to \$1.50.

EXCELLENT FLEXIBLE SANDSTONE.

A stone that will bend! What makes it bend? Buy a specimen and see if you can discover the secret. Splendid specimens, 3 x 1 inches, 5c.; 5 x 2 inches, 10c.; 7 x 2 inches, 20c.; on up to 13 x 2½ inches, 75c.; and even larger specimens. We call your attention to the fact that these prices are unprecedentedly low. Do not lose this opportunity to secure a good specimen if you have not already purchased one.

CROOKESITE.

A few specimens remain in stock. Prices, 50c. to \$20.

OTHER IMPORTANT RECENT ADDITIONS.

Mohawkite, *Stibiodomeykite*, *Domeykite* from the Mohawk Mine, each piece tested.

Povisite, doubly terminated crystals in the matrix.

Australian Atacamite, *Cerussite*, *Anglelite*, *Pyromorphite*, *Iodyrite*, *Embolite*, *Cuprite*, *Marshite*, *Stolzite*, etc.

New and rare species from Greenland.

Iridescent Pyrite from New Jersey, fine *Milky Quartz* crystals from Suttrop, *Lead* from Franklin, showy massive *Bornite*, *Millerite* in radiating crystals from Antwerp, many fine *Barites*, *Calcites*, *Fluorites*, *Hematite* and *Quartz*, *Sphalerites*, etc., from England.

JUST RECEIVED.

Covellite, from Wyoming, a new find.

Wollastonite, *Rhodonite*, *Willemite*, etc., from Franklin.

OUR SPRING BULLETIN.

24 pages, 29 illustrations, will be sent free to anyone desiring it. It describes many other recent additions to our stock and gives a complete list of Mineralogical Books.

124-page *Illustrated Catalogue*, giving Dana Species number, crystal system, hardness, specific gravity, chemical composition and formula of every mineral, 25c. in paper.

44-page *Illustrated Price-Lists*, also *Bulletins and Circulars free*.

GEO. L. ENGLISH & CO., Mineralogists,

Dealers in Scientific Minerals,

3 and 5 West 18th Street (First Door West Fifth Ave.),
New York City.

CONTENTS.

	Page
ART. I.—Geology of the Shonkin Sag and Palisade Butte Laccoliths in the Highwood Mountains of Montana; by W. H. WEED and L. V. PIRSSON	1
II.—Manganese Ore Deposits of the Queluz (Lafayette) District, Minas Geraes, Brazil; by O. A. DERBY	18
III.—Bituminous Deposits situated at the South and East of Cardenas, Cuba; by H. E. PECKHAM	33
IV.—Mineralogical Notes, No. 2; by A. F. ROGERS	42
V.—New Solution for the Copper Voltmeter; by W. K. SHEPARD	49
VI.—Thermo-magnetic and Galvano-magnetic Effects in Tellurium; by M. G. LLOYD	57
VII.—Additions to the Avifauna of the Bermudas with diagnoses of two new Subspecies; by A. H. VERRILL	64
VIII.—Induced Alternating Current Discharge studied with Reference to its Spectrum and especially the Ultra-Violet Spectrum; by A. W. WRIGHT and E. S. DOWNS	66

SCIENTIFIC INTELLIGENCE.

Chemistry and Physics—Ignition temperature of Phosphorus, EYDMAN: Composition of "Caro's Acid," BAEYER and VILIGER, 73.—Vitrified Quartz, SHENSTONE, 74.—Influence of Magnetism upon Supersaturated Solutions, DE HEMPTINNE: Ammonium Cyanate, WALKER and WOOD: Selenium in Sulphuric Acid, JOUVE, 75.—Qualitative Chemical Analysis: Viscosity of Argon, SCHULTZE: Conductivity in Hydrogen and Carbonic Acid Gas, TOWNSEND and KIRKBY: E.M.F. of Clark- and Weston-Cell, JAEGER and LINDECK, 76.—Electrical Flow in Gases, STARK: Treatise on Electro-Magnetic Phenomena, LYONS, 77.

Geology and Natural History—Eocene Deposits of Maryland, and Systematic Paleontology, 77.—Annual Report Geol. Survey Arkansas, 1892, 78.—Summary Report Geol. Survey Canada, 1900: Revision of Genera and Species of Canadian Paleozoic Corals, LAMBE, 79.—Amygdaloidal Melaphyre in Mass., BURR, 80.—Explosive Activity of Vesuvius, MATTEUCCI: Der Vulcan Etinde in Kamerun und seine Gesteine, ESCH, 81.—Söndre Helgeland, VOGT, 82.—Classification of Igneous Rocks, FEDEROW, 83.—Boletin del Instituto Geologico de Mexico: Brief Notices of recently described Minerals, 84.—Iron Meteorites, 86.—Milchsaft und Schleimsaft der Pflanzen, MOLISCH, 87.—Remarkable Instance of Death of Fishes at Bermuda, VERRILL, 88.

Miscellaneous Scientific Intelligence—Atlas Meteorologico de la Republica Argentina, 88.—British Museum Catalogues: Select Bibliography of Chemistry, 1492-1897: Publications Bureau of American Ethnology: Field Columbian Museum: Scientia, 89.—Zoologisches Addressbuch: Publications Earthquake Investigating Committee; Publications U. S. Naval Observatory, 90.

Established by BENJAMIN SILLIMAN in 1818.

THE
AMERICAN
JOURNAL OF SCIENCE.

EDITOR: EDWARD S. DANA.

ASSOCIATE EDITORS.

PROFESSORS GEO. L. GOODALE, JOHN TROWBRIDGE,
W. G. FARLOW AND WM. M. DAVIS, OF CAMBRIDGE,

PROFESSORS A. E. VERRILL, HENRY S. WILLIAMS AND
L. V. PIRSSON, OF NEW HAVEN.

PROFESSOR GEORGE F. BARKER, OF PHILADELPHIA,
PROFESSOR JOSEPH S. AMES, OF BALTIMORE,
MR. J. S. DILLER, OF WASHINGTON.

FOURTH SERIES.

VOL. XII—[WHOLE NUMBER, CLXII.]

No. 68.—AUGUST, 1901.

NEW HAVEN, CONNECTICUT.

1901.

THE TUTTLE, MOREHOUSE & TAYLOR CO., PRINTERS, 125 TEMPLE STREET.

Published monthly. Six dollars per year. \$6.40 to countries in the Postal Union. Remittances should be made either by money orders, registered letters, or bank checks (preferably on New York banks).

MONTANA.

Several shipments of interesting minerals from Montana have lately been received, a number of the most notable being reviewed below. The great mineral wealth of this district is well-known, and to its present activity is due the increasing number of mineral species reported.

CRYSTALLIZED RHODOCHROSITE. Characteristic rhombohedrons of a rich pink in aggregates, clean cut and perfect. They lack the translucency of the Colorado find, but in other features closely resemble the material from that state. Crystals vary in size from $\frac{1}{4}$ to an inch and more across with corresponding thickness. Occasionally, groups are coated with a white drusy quartz making an association both interesting and attractive. Prices 50c. to \$2.00. Massive 50c. per lb.

CRYSTALLIZED ENARGITE. A few neat groups of the rare copper sulpharsenate, illustrating habit and modifications. Crystallized metallic minerals find quick sale, and it is confidently expected that at our low scale of prices, the best of the lot will be immediately sold. Prices 50c. to \$3.00. Massive 75c. per lb.

AMETHYST. Our correspondent spent several months at the Amethyst locality, and after much difficulty succeeded in securing what are considered the finest specimens as yet found. The types show parallel growth, interesting capping forms and single doubly terminated crystals. Color is good, generally deepening at the tips. Convenient cabinet sizes—50c. to \$4.00.

TOURMALINITIC QUARTZ.

Two shipments of this odd occurrence permit us to describe its varied habits and strange associations. In appearance the crystals are black, due to the fine network of included Tourmaline hairs, which occasionally are widely separated, reminding one of the more common "flèches d'amour." A peculiar "stem" extends beyond the base of some crystals, around which the Quartz seems to have formed. The Tourmaline is often isolated on the "stem," appearing in bristling tufts and masses. The very fact that these specimens differ widely from the usual Quartz forms, makes them attractive to the collector, but aside from this point they combine such interesting features scientifically, that a steady demand is anticipated. Prices 50c. to \$3.50 in 2 and 4 inch sizes.

COVELLITE, CHALCOCITE and BORNITE in pure massive lumps neatly trimmed to cabinet sizes. 50c. to \$1.00 for a typical specimen. Trial orders solicited. Approval consignments submitted.

FOOTE MINERAL CO.,

FORMERLY DR. A. E. FOOTE,

WARREN M. FOOTE, Manager.

ESTABLISHED 1876.

PHILADELPHIA,
1317 Arch Street.

PARIS,
24 Rue du Champ de Mars.

SPECIMEN BARGAINS.



We have just priced and now offer for sale another lot of miscellaneous specimens. There are few duplicates and then generally the localities are different. The prices are low, while the quality in many cases is excellent. Some specimens are now difficult to obtain, because the localities have long since been worked out or some similar reason. Such specimens as Pyromorphite, Beryl, Amethysts, etc., from Delaware County, Pa., are examples. Some specimens are valuable for their beauty, while others are valuable because they are rare. Your inspection invited.

IMPORTANT MINERALS.

We still have limited supplies of the following, previously advertised, some of the lots having been replenished, but most of them balance of stock on hand.

Mohawkite, *Stibiodomeykite*, *Domeykite*, from the Mohawk Mine, each piece tested.

Parisite, doubly terminated crystals in the matrix.

Australian Atacamite, *Cerussite*, *Anglesite*, *Pyromorphite*, *Iodyrite*, *Embolite*, *Cuprite*, *Marshite*, *Stolzite*, etc.

New and rare species from Greenland.

Iridescent Pyrite from New Jersey, fine *Milky Quartz* crystals from Suttrop, *Lead* from Franklin, showy massive *Bornite*, *Millerite* in radiating crystals from Antwerp, many fine Barites, Calcites, Fluorites, Hematite and Quartz, Sphalerite, etc., from England.

MOLYBDENITE.

This important mineral is generally found in rounded, ill-defined crystals, when they may be called crystals at all. Choice crystals of Molybdenite have always been high-priced and not at all common. Of the large lot of unusually well defined crystals offered last month from a new locality in the far west, we still have a good supply. Well-formed crystals, one inch to four inches in diameter, with low pyramids of about 40 and 55 degrees, 10c. to \$1.50.

EXCELLENT FLEXIBLE SANDSTONE.

A stone that will bend! What makes it bend? Buy a specimen and see if you can discover the secret. Splendid specimens, 3 x 1 inches, 5c.; 5 x 2 inches, 10c.; 7 x 2 inches, 20c.; on up to 13 x 2½ inches, 75c.; and even larger specimens. We would call your attention to the fact that these prices are unprecedentedly low. Do not lose this opportunity to secure a good specimen if you have not already secured one.

RECENTLY RECEIVED.

Covellite, from Wyoming, a new find.

Wollastonite, *Rhodonite*, *Willemite*, etc., from Franklin.

FREE TO TEACHERS.

On request we will send free to teachers, our pamphlet, "Suggestions to Teachers of Mineralogy." A postal will secure it.

OUR SPRING BULLETIN.

124-page *Illustrated Catalogue*, giving Dana Species number, crystal system, hardness, specific gravity, chemical composition and formula of every mineral, 25c. in paper.

44-page *Illustrated Price-Lists*, also *Bulletins and Circulars*, free.

GEO. L. ENGLISH & CO., Mineralogists,

Dealers in Scientific Minerals,

3 and 5 West 18th Street (First Door West of Fifth Ave.),
New York City.

CONTENTS.

	Page
ART. IX.—Experiments on High Electrical Resistance, Part II; by O. N. ROOD	91
X.—Mineralogical Notes; by A. J. MOSES	98
XI.—Motion of Compressible Fluids; by J. W. DAVIS.....	107
XII.—Action of Sodium Thiosulphate on Solutions of Metallic Salts at High Temperatures and Pressures; by J. T. NORTON, JR.	115
XIII.—Secondary Undulations Shown by Recording Tide-gauges; by A. W. DUFF	123
XIV.—Mathematical Notes to Rival Theories of Cosmogony; by O. FISHER.....	140
XV.—Studies of Eocene Mammalia in the Marsh Collection, Peabody Museum; by J. L. WORTMAN.....	143
XVI.—Electromagnetic Effects of Moving Charged Spheres; by E. P. ADAMS	155
XVII.—The Nadir of Temperature and Allied Problems; by J. DEWAR	168

SCIENTIFIC INTELLIGENCE.

- Miscellaneous Scientific Intelligence*—Magnetic effect of Electrical Convection, H. PENDER, 173.—American Association for the Advancement of Science, 174.
- Obituary*.—DR. JOSEPH LÉCONTE: PROFESSOR PETER GUHTRIE TAIT, 174.

VOL. XII.

SEPTEMBER, 1901.

Established by BENJAMIN SILLIMAN in 1818.

THE
AMERICAN
JOURNAL OF SCIENCE.

EDITOR: EDWARD S. DANA.

ASSOCIATE EDITORS

PROFESSORS GEO. L. GOODALE, JOHN TROWBRIDGE,
W. G. FARLOW AND WM. M. DAVIS, OF CAMBRIDGE,

PROFESSORS A. E. VERRILL, HENRY S. WILLIAMS AND
L. V. PIRSSON, OF NEW HAVEN.

PROFESSOR GEORGE F. BARKER, OF PHILADELPHIA,

PROFESSOR JOSEPH S. AMES, OF BALTIMORE,

MR. J. S. DILLER, OF WASHINGTON.

FOURTH SERIES.

VOL. XII—[WHOLE NUMBER, CLXII.]

No. 69.—SEPTEMBER, 1901.

NEW HAVEN, CONNECTICUT.

1901.

THE TUTTLE, MOREHOUSE & TAYLOR CO., PRINTERS, 125 TEMPLE STREET.

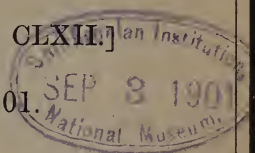

Published monthly. Six dollars per year. \$6.40 to countries in the Postal Union. Remittances should be made either by money orders, registered letters, or bank checks (preferably on New York banks).

MONTANA.

Several shipments of interesting minerals from Montana have lately been received, a number of the most notable being reviewed below. The great mineral wealth of this district is well-known, and to its present activity is due the increasing number of mineral species reported.

CRYSTALLIZED RHODOCHROSITE. Characteristic rhombohedrons of a rich pink in aggregates, clean cut and perfect. They lack the translucency of the Colorado find, but in other features closely resemble the material from that state. Crystals vary in size from $\frac{1}{4}$ to an inch and more across with corresponding thickness. Occasionally, groups are coated with a white drusy quartz making an association both interesting and attractive. Prices 50c. to \$2.00. Massive 50c. per lb.

CRYSTALLIZED ENARGITE. A few neat groups of the rare copper sulpharsenate, illustrating habit and modifications. Crystallized metallic minerals find quick sale, and it is confidently expected that at our low scale of prices, the best of the lot will be immediately sold. Prices 50c. to \$3.00. Massive 75c. per lb.

AMETHYST. Our correspondent spent several months at the Amethyst locality, and after much difficulty succeeded in securing what are considered the finest specimens as yet found. The types show parallel growth, interesting capping forms and single doubly terminated crystals. Color is good, generally deepening at the tips. Convenient cabinet sizes—50c. to \$4.00.

TOURMALINITIC QUARTZ.

Two shipments of this odd occurrence permit us to describe its varied habits and strange associations. In appearance the crystals are black, due to the fine network of included Tourmaline hairs, which occasionally are widely separated, reminding one of the more common "fêches d'amour." A peculiar "stem" extends beyond the base of some crystals, around which the Quartz seems to have formed. The Tourmaline is often isolated on the "stem," appearing in bristling tufts and masses. The very fact that these specimens differ widely from the usual Quartz forms, makes them attractive to the collector, but aside from this point they combine such interesting features scientifically, that a steady demand is anticipated. Prices 50c. to \$3.50 in 2 and 4 inch sizes.

COVELLITE, CHALCOCITE and BORNITE in pure massive lumps neatly trimmed to cabinet sizes. 50c. to \$1.00 for a typical specimen. Trial orders solicited. Approval consignments submitted.

FOOTE MINERAL CO.,

FORMERLY DR. A. E. FOOTE,

WARREN M. FOOTE, Manager.

ESTABLISHED 1876.

PHILADELPHIA,
1317 Arch Street.

PARIS,
24 Rue du Champ de Mars.



328 BEAUTIFULLY CRYSTALLIZED RHODOCHROSITES.

The largest number of Rhodochrosite specimens we have ever secured was recently received from Colorado. The few obtained last spring were quickly sold. The present collection contains an assortment of sizes and prices which enables us to meet the requirements of every collector, 15c. to \$4.00. The association of green fluorite with the pink rhodochrosite forms a most pleasing combination of colors. Such specimens are higher in price, but, nevertheless, cheap at 25c. to \$6.00.

SHOWY COLORADO HÜBNERITE.

60 excellent specimens of the Cement Creek Hübnerite (formerly known as Megabasite) are just being placed on sale. No such lot has ever before been offered for sale. The dark brown, more or less radiating blades of the Hübnerite stand out in bold contrast with the white Quartz matrix, 25c. to \$3.00.

MONTANA VESUVIANITE.

A small lot of the showy Montana Vesuvianites in blue calcite is just in, \$1.00 and \$1.25.

APATITE CRYSTALS.

A large lot of Canadian Apatite crystals arrived during August. Quite a number of them are doubly terminated and of good size, 35c. to \$2.00; others have a single good termination, 10c. to 25c. They are most excellent illustrations not only of the mineral but of the hexagonal system.

RECENT FINDS AT FRANKLIN.

It seems likely that the day will soon be past when specimens of any kind will be obtainable from Franklin Furnace. We have been buying up everything really good (but *no rubbish*) and can offer many attractive specimens of **crystallized Rhodonite**, **pink zinciferous Wollastonite**, **Bementite**, **Caswellite**, **Leucophoenicite**, **Hancockite**, **Polyadelphite Garnets**, etc. Our accessions during August have included many exceptionally desirable specimens—all at most reasonable prices.

AUSTRALIAN MINERALS.

200 **Atacamites** are now on sale at low prices, 25c. to \$2.50. Many choice **Embolites** at 25c. to \$10.00; **Cerussites** at 25c. to \$3.50; **Anglesites** in groups of crystals coating reticulated **Cerussite**, 50c. to \$6.00; **Cuprite**, loose crystals, 5c. to 15c.; matrix groups of **Cobaltite** crystals, \$1.00 to \$2.00; **Pyromorphite**, extra good, \$2.00 to \$3.50. Also many other desirable specimens such as reticulated **Copper**, **Azurite**, **Gold Quartz**, **Molybdenite**, **Cassiterite**, **Iodyrite**, **Stolzite**, **Silver**, crystallized **Smithsonite**, crystallized **Chalcocopyrite**, etc.

We are now selling our sixth hundred of the peerless *Penfield Contact Goniometers*, the cheapest, yet the best ever on sale. No crystallographer can afford to do without them. Two models, 50c. each: \$5.00 per dozen.

124-page *Illustrated Catalogue*, giving Dana Species number, crystal system, specific gravity, chemical composition and formula of every mineral, 25c. in paper. 44-page *Illustrated Price-Lists*, also *Bulletins and Circulars*, free.

GEO. L. ENGLISH & CO., Mineralogists,

Dealers in Scientific Minerals,

3 and 5 West 18th Street (First Door West of Fifth Ave.),
New York City.

CONTENTS.

	Page
ART. XVIII.—Discharge-current from a Surface of large Curvature; by J. E. ALMY	175
XIX.—Octahedrite and Brookite, from Brindletown, North Carolina; by H. H. ROBINSON	180
XX.—Behavior of Small closed Cylinders in Organ-pipes; by B. DAVIS	185
XXI.—Cæsium-Tellurium Fluoride; by H. L. WELLS and J. M. WILLIS	190
XXII.—Double Chlorides of Cæsium and Thorium; by H. L. WELLS and J. M. WILLIS	191
XXIII.—Studies of Eocene Mammalia in the Marsh Collection, Peabody Museum; by J. L. WORTMAN	193
XXIV.—Separation of the Least Volatile Gases of Atmospheric Air, and their Spectra; by G. D. LIVEING and J. DEWAR	207
XXV.—Estimation of Calcium, Strontium, and Barium, as the Oxalates; by C. A. PETERS	216
XXVI.—Calaverite; by S. L. PENFIELD and W. E. FORD	225

SCIENTIFIC INTELLIGENCE.

Miscellaneous Scientific Intelligence—Temporary Set, C. BARUS; Some new rock-types, 247.

Obituary—JOSEPH LÉCONTE, 248.

Established by BENJAMIN SILLIMAN in 1818.

THE
AMERICAN
JOURNAL OF SCIENCE.

EDITOR: EDWARD S. DANA.

ASSOCIATE EDITORS

PROFESSORS GEO. L. GOODALE, JOHN TROWBRIDGE,
W. G. FARLOW AND WM. M. DAVIS, OF CAMBRIDGE,

PROFESSORS A. E. VERRILL, HENRY S. WILLIAMS AND
L. V. PIRSSON, OF NEW HAVEN.

PROFESSOR GEORGE F. BARKER, OF PHILADELPHIA,

PROFESSOR JOSEPH S. AMES, OF BALTIMORE,

MR. J. S. DILLER, OF WASHINGTON.

FOURTH SERIES.

VOL. XII—[WHOLE NUMBER, CLXII.]

No. 70.—OCTOBER, 1901.

WITH PLATES I-VI.



NEW HAVEN, CONNECTICUT.

1901.

THE TUTTLE, MOREHOUSE & TAYLOR CO., PRINTERS, 125 TEMPLE STREET.

Published monthly. Six dollars per year. \$6.40 to countries in the Postal Union. Remittances should be made either by money orders, registered letters, or bank checks (preferably on New York banks).

STANDARD COLLECTION OF ORES

REQUIRED FOR

Osborn's Prospector's Field Book and Guide.

An indispensable aid and guide to users of this book.

The list of 120 specimens includes all important minerals mentioned in the text, besides illustrating the Scale of Hardness and the six systems of Crystallization.

In selecting specimens from our large stock, a collection is secured which represents, in a brief way, the varieties with which the prospector or miner is most likely to meet, and it has, therefore, a thoroughly practical value.

The following sizes are kept in stock ready for shipment. With the neat and durable oak cases they can be kept in small space. Every specimen is accurately labeled with name, composition and locality, and numbered to correspond to list.

No. 23. Prospectors', \$16.00. 120 specimens, averaging $2\frac{1}{2} \times 2$ in. Handsome oak case, three drawers, fitted with pasteboard trays, \$10.25 extra.

No. 24. Prospectors', \$7.00. 120 specimens, averaging $1\frac{1}{2} \times 1\frac{1}{2}$ in. Oak compartment case, \$1.60 extra.

The following special sets of ores are put up to order:

No. 25. Useful Metallic and Non-Metallic Minerals. 300 specimens, averaging $2\frac{1}{2} \times 2$ in., \$125.00. Includes various examples of all important minerals possessing economic value.

No. 27. Metallurgical Collection. 200 specimens, averaging $2\frac{1}{2} \times 2$ in., \$90.00. Embracing all the more important ores of common, rare or precious metals.

No. 29. Metallurgical Collection. 100 specimens, averaging $2\frac{1}{2} \times 2$ in., \$25.00. An abridgement of No. 27.

No. 32. Ore Associations. 60 specimens, averaging $2\frac{1}{2} \times 2$ in., \$12.00. Including all of the minerals most commonly found with valuable ores.

The above are sold in $1\frac{1}{4}$ inch sizes at about half price.

No. 34. Gold ores. 10 specimens, averaging $1\frac{1}{2} \times 1\frac{1}{2}$ in., \$10.00.

No. 35. Silver ores. 15 specimens, averaging $1\frac{1}{2} \times 1\frac{1}{2}$ in., \$7.50.

Also series illustrating occurrence of IRON, LEAD, COPPER, ZINC, NICKEL AND COBALT, AND THE RARE ELEMENTS; ROUGH GEMS AND PRECIOUS STONES.

 Minerals purchased in quantity. Send small mail samples.

FOOTE MINERAL CO.,

FORMERLY DR. A. E. FOOTE,

WARREN M. FOOTE, Manager.

ESTABLISHED 1876.

PHILADELPHIA,

1317 Arch Street.

PARIS,

24 Rue du Champ de Mars.

FINE PENNSYLVANIA GARNETS.



The peculiar excellence of the Garnets from Delaware and Chester Counties, Pennsylvania, is not so well known as might be supposed, largely because local collectors have bought them up with such avidity as not only to absorb the entire supply but also to run the prices up to figures which outside collectors would not pay—\$10.00 to \$35.00 each. We have just obtained 26 specimens from a collector who has held them for many years and finally sold them out cheaply. The best of them are very good, all are above the average, but the prices are only 25c. to \$2.50. They are Spessartites of large sizes, 1 inch to 3 inches, quite perfect, fairly bril-

liant, dark brown or brownish-red and are mostly implanted on a quartz-feldspar matrix.

PENNSYLVANIA BERYLS.

The same collector sold us quite a good lot of Delaware County Beryls, both loose and on the matrix, which we are selling at low prices, 10c. to \$1.00.

RARE SPECIES.

From an old collection we have obtained many species which we are able to offer at much lower prices than usually prevail among European dealers. Among them we would mention Pyrochlore xls on matrix, Polycrase xled, Ludlamite xled, Bergmannite, Sarcolite, Humboldtite xled, Dewalquite, Tritomite, Websterite, Hielmite, Pyrrhite, Ittnerite, Praseolite, Aspasolite, Voigtite, Romanzovite, Breithauptite, Dipyre, Polymignite, Yttrotantalite, Acmite, Tachyphalite, Randidite. There are many other equally desirable species and *all are at low prices.*

BRAZILIAN PYRITE TWINS.

Over 100 *extra large and fine* twinned pyritohedrons of Pyrite from Brazil have just been secured. Though much better than any ever before in stock we can sell them at but 10c. to 35c. each. No lover of crystallography should miss this opportunity.

RICH, POLISHED RUSSIAN MALACHITE.

Russian Malachite is famed the world over. The present consignment consists of 15 specimens, some small pieces at 35c. to 50c. each, a few elegant large pieces at \$10.00, \$12.50 and \$15.00. We also have in stock a few choice polished specimens from Arizona, some of them associated with Azurite.

MONTANA VESUVIANITES.

The second recent collection of the Beautiful Montana Vesuvianites has just arrived. It is but a small lot which will doubtless all be sold quickly, but if your order comes promptly it may secure for you a better specimen than any you have yet seen. 75c. to \$2.00.

COLORADO RHODOCHROSITES AND HÜBNERITES.

The delicate pink rhodochrosites with green fluorite advertised last month are worthy of another and much more extended notice than we can here give them. Never before has so large a lot been offered for sale, nor have the prices been so reasonable, 15c. to \$2.00, with a few extra fine specimens at \$2.50 to \$6.00. The *Hübnerites* are much the best ever on sale, the rich, dark-brown color of the radiating blades contrasting most pleasingly with the white quartz matrix. 25c. to \$3.00.

We are now selling our sixth hundred of the peerless *Penfield Contact Goniometers*, the cheapest, yet the best ever on sale. No crystallographer can afford to do without them. Two models, 50c. each: \$5.00 per dozen.

124-page *Illustrated Catalogue*, giving Dana Species number, crystal system, specific gravity, chemical composition and formula of every mineral, 25c. in paper. 44-page *Illustrated Price-Lists*, also *Bulletins and Circulars*, free.

GEO. L. ENGLISH & CO., Mineralogists,

Dealers in Scientific Minerals,

3 and 5 West 18th Street (First Door West of Fifth Ave.),
New York City.

CONTENTS.

	Page
ART. XXVII.—Galvanometers of High Sensibility; by C. E. MENDENHALL and C. W. WAIDNER	249
XXVIII.—Method of Locating Nodes and Loops of Sound in the Open Air with Applications; by B. DAVIS.	263
XXIX.—Anatomy of the Fruit of <i>Cocos nucifera</i> ; by A. L. WINTON	265
XXX.—Studies of Eocene Mammalia in the Marsh Collection, Peabody Museum; by J. L. WORTMAN. With Plates I-IV	281
XXXI.—Crinoid from the Hamilton of Charlestown, Indiana; by E. WOOD. With Plate V	297
XXXII.—Estimation of Cæsium and Rubidium as the Acid Sulphates, and of Potassium and Sodium as the Pyrosulphates; by P. E. BROWNING	301
XXXIII.—Time Values of Provincial Carboniferous Terranes; by C. R. KEYES	305
XXXIV.—Spectra of Hydrogen and some of its Compounds; by J. TROWBRIDGE. With Plate VI.	310

SCIENTIFIC INTELLIGENCE.

Chemistry and Physics—Induced Radio-activity produced by Salts of Radium, P. CURIE and A. DEBIERNE, 319—New Method of Quantitative Analysis, R. W. THATCHER, 320.—Europium, a New Element, DEMARÇAY: Research Papers from the Kent Chemical Laboratory of Yale University, F. A. GOOCH, 321.—Magnetic Effect of Electrical Convection, H. A. WILSON: Effect of Amalgamated Gases on Resistance, W. ROLLINS, 322.

Miscellaneous Scientific Intelligence—American Association, 323.—British Association: Catalogue of the African Plants collected by Dr. F. Welwitsch in 1853-61: Vol. II, Part II, Cryptogamia; Leitfaden der Wetterkunde, gemeinverständlich bearbeitet, R. BÖRNSTEIN, 324.—Studien über die Narkose, E. OVERTON: Ueber Harmonie und Complication, V. GOLDSCHMIDT: Nature's Miracles, Familiar Talks on Science, E. GRAY, 325.

Obituary—CHARLES ANTHONY SCHOTT: BARON ADOLF ERIK NORDENSKIÖLD: Dr. WILHELM SCHUR: BARON DE LACAZE-DUTHIERS, 326.

Established by BENJAMIN SILLIMAN in 1818.

THE
AMERICAN
JOURNAL OF SCIENCE.

EDITOR: EDWARD S. DANA.

ASSOCIATE EDITORS

PROFESSORS GEO. L. GOODALE, JOHN TROWBRIDGE,
W. G. FARLOW AND WM. M. DAVIS, OF CAMBRIDGE,

PROFESSORS A. E. VERRILL, HENRY S. WILLIAMS AND
L. V. PIRSSON, OF NEW HAVEN.

PROFESSOR GEORGE F. BARKER, OF PHILADELPHIA,

PROFESSOR JOSEPH S. AMES, OF BALTIMORE,

MR. J. S. DILLER, OF WASHINGTON.

FOURTH SERIES.

VOL. XII—[WHOLE NUMBER, CLXII.]

No. 71.—NOVEMBER, 1901.

WITH PLATE VII.

NEW HAVEN, CONNECTICUT.

1901.

THE TUTTLE, MOREHOUSE & TAYLOR CO., PRINTERS, 125 TEMPLE STREET.

Published monthly. Six dollars per year. \$6.40 to countries in the Postal Union. Remittances should be made either by money orders, registered letters, or bank checks (preferably on New York banks).

JUST OUT!

New 64-Page

“Collection Catalog”

Numerous full-page photo-engravings.
Gives prices and descriptions of :
Minerals for Study and Reference arranged in Systematic Collections.
Sets of Ores for Prospectors.
Detached Crystals for Measurement.
Series illustrating Hardness, Color and other Physical Characters.
Laboratory Minerals sold by Weight.
Sundry Supplies, etc.

Mailed Free to any address.

*Sweeping Reductions in Prices of Specimens for Museums,
Private Collectors and Students.*

NEW ACCESSIONS

From European and American localities. Over seventy boxes of fresh stock lately received. A more detailed announcement will shortly appear.

FOOTE MINERAL CO.,

FORMERLY DR. A. E. FOOTE,

The Largest and Best Equipped Mineral Supply-House in the World.

Highest Awards at Nine Great Expositions.

ESTABLISHED 1876.

PHILADELPHIA,
1317 Arch Street.

PARIS,
24 Rue du Champ de Mars.

Our Leaflet "Fall Announcements"



Published during October, will give some idea of the many recent additions to our stock. If you have not yet received a copy, drop us a card and it will be at once mailed to you.

IMPROVED MINERAL COLLECTIONS.

The rapid strides in the science of mineralogy and the many and important new finds, the best of which naturally come to us, make frequent revisions of scientific collections of minerals imperative. It has always been our policy to keep our collections right up to date. Those which we are now putting up are materially better than those which were put up a year ago, and far superior to those put up in 1894 when the last edition of our complete catalogue was published. It is safe to state that *our collections are 25 per cent. better than they were in 1894.*

OUR COLLECTIONS OF LOOSE CRYSTALS

Are not only composed of better crystals, but much more care is exercised in their selection and each collection is accompanied by a catalogue enumerating the forms of the crystals. Prices, \$5.00, \$10.00, \$25.00 and \$50.00.

OUR PHYSICAL COLLECTIONS

Are unapproached by any others in the market.

OUR BLOWPIPE COLLECTIONS

Have just been revised (October, 1901) and any student buying one of them will find it of inestimable assistance in his laboratory work. The leading works on determinative mineralogy have been studied from beginning to end in order to make it certain that everything essential for a student of any one of these books to have is included in our collection of 200 specimens at \$8.00, while the smaller collections, 100 for \$3.50, 50 for \$1.50, 25 for 75c., contain the most important of the species. All of these collections are put up in handsome quartered oak compartment boxes without extra charge.

OUR SYSTEMATIC COLLECTIONS OF MINERALS

Range in price from 75c. to \$1,000, and each collection is so carefully selected that its scientific worth is much more than its price. Our "Dana" Collection, No. 1, 125 specimens averaging 2 x 2 inches, \$10.00, has attained an international reputation, no ten dollar collection ever before on the market being comparable to it. Our "Manhattan" School Collections at \$1.00 and \$2.00 are meeting with success which would be wonderful were it not so well deserved, over 500 of them having been sold to one school. Our 12-page illustrated leaflet, "*Suggestions to Teachers of Mineralogy,*" quite fully describes them.

GEO. L. ENGLISH & CO., Mineralogists,

Dealers in Educational and Scientific Minerals,

3 AND 5 WEST 18th STREET, NEW YORK CITY.

CONTENTS.

	Page
ART. XXXV.—Effect of Temperature and of Moisture on the Emanation of Phosphorus, and on a Distinction in the Behavior of Nuclei and of Ions; by C. BARUS.....	327
XXXVI.—Determination of the Heat of Dissociation and of Combustion of Acetylene, Ethylene and Methane; by W. G. MIXTER.....	347
XXXVII.—Geological Relations and the Age of the St. Joseph and Potosi Limestones of St. François County, Missouri; by F. S. NASON.....	358
XXXVIII.—Cambrian Fossils of St. François County, Missouri; by C. E. BEECHER.....	362
XXXIX.—Discovery of Eurypterid Remains in the Cambrian of Missouri; by C. E. BEECHER. With Plate VII	364
XL.—Determination of Persulphates; by C. A. PETERS and S. E. MOODY.....	367
XLI.—Studies of Eocene Mammalia in the Marsh Collection, Peabody Museum; by J. L. WORTMAN.....	377
XLII.—Carboniferous and Permian Age of the Red Beds of Eastern Oklahoma from Stratigraphic Evidence; by G. I. ADAMS.....	383

SCIENTIFIC INTELLIGENCE.

- Chemistry and Physics*—New Method for Producing Aniline and the Analogous Bases, SABATIER and SENDERENS: Existence of Ammonium, O. RUFF, 387.—Modified Gooch-Crucible, W. C. HERAEUS: Radio-active Lead, HOFMANN and STRAUSS, 388.—Salt of Quadrivalent Antimony, WELLS and METZGER: New Method for the Gravimetric Determination of Tellurium, GUTBIER: Diffusion of Hydrogen through Palladium, A. WINKELMANN: Cathode Rays, W. SEITZ, 389.—Photography of the Infra-Red Spectra of the Alkali-metals, H. LEHMANN: Ether and Gravitational Matter through Infinite Space, LORD KELVIN, 390.—Nineteenth Century Cloud over the Dynamical Theory of Heat and Light, LORD KELVIN, 391.—Resistance and Electromotive forces of the Electric Arc, W. DUDELL, 392.—Unsolved Problems in Low-Temperature Research, A. M. CLERKE, 393.
- Geology and Mineralogy*—Geological Survey of Canada, G. M. DAWSON, 394.—Geological Survey of Canada, R. BELL and J. F. WHITEAVES: Geological and Natural History Survey of Minnesota, 1900-1901, N. H. WINCHELL, 395.—Iowa Geological Survey, S. CALVIN: Dragons of the Air, an account of Extinct Flying Reptiles, H. G. SEELEY, 396.—Contributions to Mineralogy and Petrography from the Laboratories of the Sheffield Scientific School of Yale University, S. L. PENFIELD and L. V. PIRSSON: Large Phlogopite Crystal, W. H. MCNAIRN, 398.—Handbuch der Mineralogie, C. HINTZE, 399.
- Miscellaneous Scientific Intelligence*—Meteorite Swarms, A. G. HÖGBOM, 399.—American Philosophical Society of Philadelphia, 400.

Established by BENJAMIN SILLIMAN in 1818.

THE
AMERICAN
JOURNAL OF SCIENCE.

EDITOR: EDWARD S. DANA.

ASSOCIATE EDITORS

PROFESSORS GEO. L. GOODALE, JOHN TROWBRIDGE,
W. G. FARLOW AND WM. M. DAVIS, OF CAMBRIDGE,

PROFESSORS A. E. VERRILL, HENRY S. WILLIAMS AND
L. V. PIRSSON, OF NEW HAVEN.

PROFESSOR GEORGE F. BARKER, OF PHILADELPHIA,
PROFESSOR JOSEPH S. AMES, OF BALTIMORE,
MR. J. S. DILLER, OF WASHINGTON.

FOURTH SERIES.

VOL. XII—[WHOLE NUMBER, CLXII.]

No. 72.—DECEMBER, 1901.

WITH PLATES VIII-IX.

NEW HAVEN, CONNECTICUT.

1901.

170444

THE TUTTLE, MOREHOUSE & TAYLOR CO., PRINTERS, 125 TEMPLE STREET.

Published monthly. Six dollars per year. \$6.40 to countries in the Postal Union. Remittances should be made either by money orders, registered letters, or bank checks (preferably on New York banks).

POLISHED MINERALS.

Our large stock of polished specimens includes many showy things. They are suitable for the cabinet, being finished on one face, leaving the natural fracture on back and edges. Those who love an odd formation, combined with bright color, will find the following of high decorative value. The crystals possess a natural polish equal to the best lapidary work.

Amazon-stone crystal.	Jasperized Wood.	Rock Crystal.
Amber with insects.	Labradorite.	Rose Quartz.
Amethyst crystals.	Malachite.	Sodalite.
Aventurine (Sunstone).	Meteoric Iron.	Sulphur crystals.
Barite crystal.	Moss Agate.	Turquoise in Matrix.
Fluorite crystals.	Opal in Matrix.	Variscite.
Garnet.	Onyx Marble.	Verd-Antique.
Hematite crystals.	Opalized Wood.	
Iceland Spar.	Pyrite crystals.	

Prices, 50c. to \$3.00 and \$4.00 for the best.

GEMS

The brief list below is but a suggestion of our stock. All are good stones cut for mounting. Prices average one-third less than charged by jewelers.

Almandite.	Olivine.	Spessartite.
Amethyst.	Opal.	Topaz.
Aquamarine.	Peridot.	Tourmaline.
Cairngorm.	Rhodolite.	Turquoise.
Hiddenite.	Rubellite.	

NEW CATALOG

Numerous full-page photo-engravings.
Gives prices and descriptions of :
Minerals for Study and Reference arranged in Systematic Collections.
Sets of Ores for Prospectors.
Detached Crystals for Measurement.
Series illustrating Hardness, Color and other Physical Characters.
Laboratory Minerals sold by Weight.
Sundry Supplies, etc.

Mailed Free to any address.

Sweeping Reductions in Prices of Specimens for Museums, Private Collectors and Students.

NEW ACCESSIONS

From European and American localities. Over seventy boxes of fresh stock lately received. A more detailed announcement will shortly appear.

FOOTE MINERAL CO.,

FORMERLY DR. A. E. FOOTE,

The Largest and Best Equipped Mineral Supply-House in the World.
Highest Awards at Nine Great Expositions.

ESTABLISHED 1876.

PHILADELPHIA,
1317 Arch Street.

PARIS,
24 Rue du Champ de Mars.

MANY RARE AND FINE MINERALS



Have been obtained recently as the result of the purchase of a large collection, the first portion of which (to and including the oxides), embracing some 1,500 specimens, is now on sale. Many specimens from the Spang and Bement collections are included. Among species worthy of special mention are:

Brucite. A score of superb groups from Pa.

Hematite. Many magnificent Swiss groups and "Iron Roses."

Alexandrite. Several large, well formed and gemmy crystals.

Amalgam. Two crystallized specimens.

Acanthite. Several exceedingly good groups.

Argentite. Splendid groups. **Arquerite.** One good specimen.

Proustite. Extra choice loose crystals and groups.

Pyrargyrite, Polybasite and other silver minerals in fine specimens.

Corundum in brilliant, gemmy crystals from North Carolina.

Cassiterite. Exceptionally large twins and most brilliant groups—a truly grand assortment.

Fluorite. Many rare forms and fine specimens, including a three-inch pink octahedron from Switzerland.

Pyrite. Rare forms and combinations including trapezohedrons and diploids.

Chalcocite. Splendid old-time groups from Bristol and Cornwall.

Copper. Groups of remarkably sharp and well-developed crystals.

Silver. Excellent wire and crystallized specimens.

Sulphur. Very perfect loose crystals and beautiful groups.

Platinum. Good-sized nuggets and vials of little grains.

Iridosmine from several localities, some of it in distinct though very minute crystals.

Platiniridium. A very little. **Palladium.** One expensive specimen.

Chilenite. Two specimens. **Argentopyrite.** One fine specimen.

Manganite. Several extra fine groups. **Cobaltite.** Excellent crystals.

Hundreds of other very desirable minerals, of some of which there are twenty or more specimens, of others but one. Among them are fine specimens of Tetrahedrite, Nagyagite, Bournonite, Octahedrite, Aikinite, Binnite, Jordanite, Sartorite, Dufrenoyite, Antimony, Bismuth, Diamonds, Petzite, Hesseite, Dyscrasite, Tetradyrite, Freieslebenite, Matlockite, Rutile, Brookite, many varieties of Quartz and Opal, Ilmenite crystals, Franklinite in rare forms, Magnetite, etc., etc. It is, of course, impossible to do justice in these few words to so important an accession to our stock.

DEKALB DIOPSIDE CRYSTALS.

The season's output includes few large crystals but an unusual number of beautifully transparent and perfect crystals, $\frac{1}{2}$ to $1\frac{1}{4}$ inches in length. The usual unattractive character of pyroxene specimens finds no counterpart in the flashy beauty of these crystals whose popularity is so well deserved.

WONDERFUL TITANITE TWINS.

A new locality in the Province of Quebec has just yielded forty startlingly fine and large Titanite twins. They much resemble the Renfrew County twins, but we have never seen any so good from that old locality.

124-page ILLUSTRATED CATALOGUE, giving Dana Species number, crystal system, hardness, specific gravity, chemical composition and formula of every mineral, 25c. in paper.

44-page ILLUSTRATED PRICE-LISTS, also BULLETINS and CIRCULARS, FREE.

GEO. L. ENGLISH & CO., Mineralogists,

Dealers in Scientific Minerals,

3 AND 5 WEST 18th STREET, NEW YORK CITY.

CONTENTS.

	Page
ART. XLIII.—Geology of the Little Colorado Valley; by L. F. WARD	401
XLIV.—Pyrite and Marcasite; by H. N. STOKES	414
XLV.—Studies of Eocene Mammalia in the Marsh Collection, Peabody Museum; by J. L. WORTMAN. With Plates VIII and IX	421
XLVI.—Dielectric Constant of Paraffins; by W. G. HORMELL	433
XLVII.—New Mineral Occurrences in Canada; by G. C. HOFFMANN	447
XLVIII.—Estimation of Molybdic Acid reduced by Hydriodic Acid; by F. A. GOOCH and O. S. PULMAN, JR.	449
XLIX.—Veramin Meteorite, by H. A. WARD	453

SCIENTIFIC INTELLIGENCE

- Chemistry and Physics*—Double Compounds of Antimony Pentachloride, etc., ROSENHEIM and STELLMANN: Thermochemistry of Alloys, T. J. BAKER: Acid Nitrates, WELLS and METZGER, 460.—Methods of Standardizing Acid Solutions, C. G. HOPKINS, 461.—New Element Associated with Thorium, C. BASKEVILLE: Laboratory Guide to the Study of Qualitative Analysis, E. H. S. BAILEY and H. P. CADY: Elements of Qualitative Analysis, W. A. NOYES, 462.—Heterogene Gleichgewichte von Standpunkte der Phasenlehre, H. W. B. ROOZEBOOM: Viscosity of Helium, H. SCHULTZE: Air-tight glass stop-cocks, H. THIELE and M. ECKARDT: Migration of the ions, R. GANS, 463.—Photometry of the Ultra-Violet rays, H. KREUSLER, 464
- Geology and Mineralogy*—Glaciation in Tierra del Fuego and in the Antarctic, H. ARCTOWSKI, 464.—Glaciers of Switzerland in 1900, S. FINSTERWALDER and E. MURET: United States Geological Survey, C. D. WALCOTT, 465.—Indiana: Department of Geology and Natural Resources, W. S. BLATCHLEY: Geological Survey of New Jersey, Annual Report, 1900: Ice Ramparts, E. R. BUCKLEY, 466.—Syllabus of a Course of Lectures on Elementary and Economic Geology, J. C. BRANNER and J. F. NEWSOM: Loess of Iowa City and Vicinity, B. SHIMEK: River System of Connecticut, W. H. HOBBS: Sivamalai Series of Eleolite-Syenites and Corundum-Syenites in the Coimbatore Distr., Madras Presidency, T. H. HOLLAND, 467.—Peculiar Form of altered Peridotite, T. H. HOLLAND: Perknite, H. W. TURNER, 468.—Outline of Elementary Lithology, G. H. BARTON: Synchronite and Molybdophillite: Crystallization of Stannite, L. J. SPENCER: Conchite and Ktypteite, H. VATER: Meteorite of Felix, Perry County, Alabama, G. P. MERRILL, 469.
- Zoology*—Nomenclature of Bermuda Birds, A. H. VERRILL, 470.—Reports on the Fauna of Porto Rico, 471.—Papers from the Alaska Harriman Expedition, W. R. COE: Zoology: An Elementary Text Book, A. E. SHIPLEY and E. W. MACBRIDE: Elementary Course of Practical Zoology, T. J. PARKER and W. N. PARKER, 472.
- Miscellaneous Scientific Intelligence*—National Academy of Sciences, 472—Annual Report of the Board of Regents of the Smithsonian Institution, for the year ending June 30, 1900: Smithsonian Institution: Documents relative to its Origin and History, 1835–1899, W. J. RHEES, 473.—Beiträge zur chemischen Physiologie und Pathologie: Annals of Harvard College Observatory, E. C. PICKERING: Royal Society of London, Copley Medal, 474.
- Obituary*—RUDOLPH KOENIG: PROFESSOR A. F. W. SCHIMPER, 474.

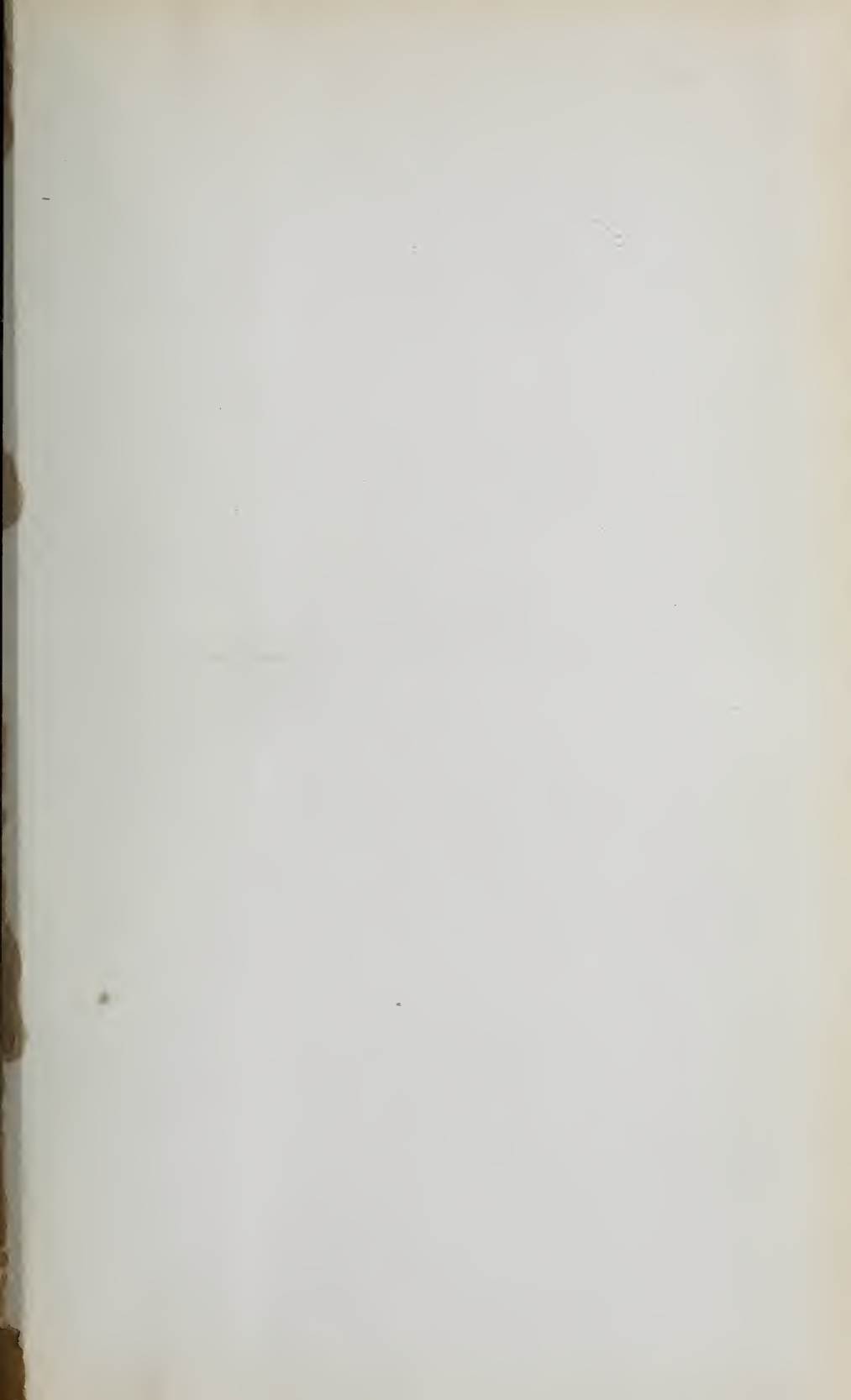



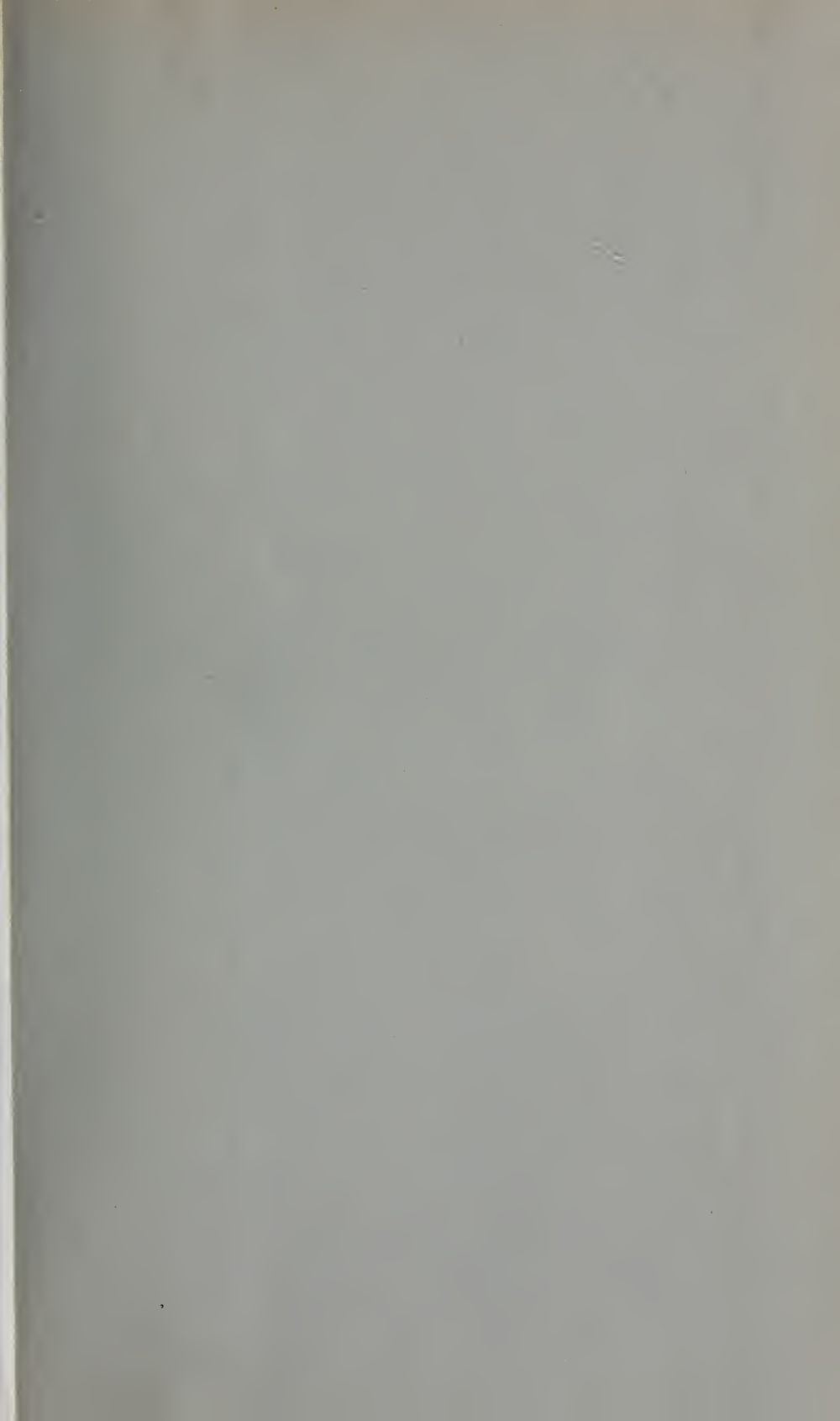

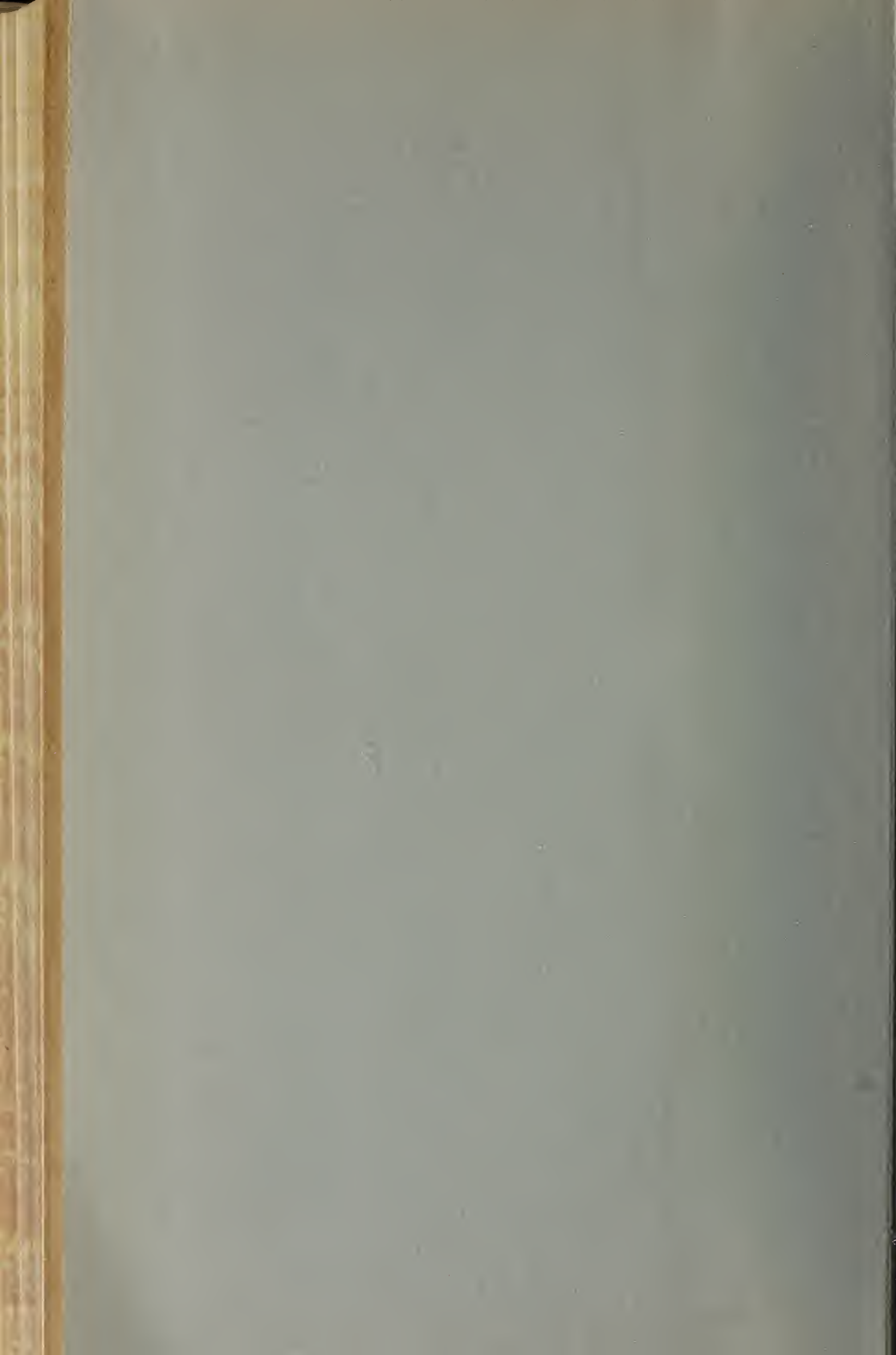

SMITHSONIAN INSTITUTION LIBRARIES



3 9088 01298 5636