



DUDLEY HUGH LITERARY  
NAVAL POSTGRADUATE SCHOOL  
MONTEREY, CA 93940











# NAVAL POSTGRADUATE SCHOOL

## Monterey, California



# THESIS

MEASURES OF PERFORMANCE FOR A  
MECHANIZED INFANTRY PLATOON AND  
SQUAD IN THE ACTIVE DEFENSE

by

Roland Walter Carter

March 1979

Thesis Advisor:  
Second Reader:

R. S. Miller  
S. H. Parry

Approved for public release; distribution unlimited.

T187824





REPORT DOCUMENTATION PAGE		READ INSTRUCTIONS BEFORE COMPLETING FORM
1. REPORT NUMBER	2. GOVT ACCESSION NO.	3. RECIPIENT'S CATALOG NUMBER
4. TITLE (and Subtitle) Measures of Performance for a Mechanized Infantry Platoon and Squad in the Active Defense		5. TYPE OF REPORT & PERIOD COVERED Master's Thesis, March, 1979
7. AUTHOR(s)  Roland Walter Carter		6. PERFORMING ORG. REPORT NUMBER
9. PERFORMING ORGANIZATION NAME AND ADDRESS Naval Postgraduate School Monterey, California 93940		8. CONTRACT OR GRANT NUMBER(s)
11. CONTROLLING OFFICE NAME AND ADDRESS Naval Postgraduate School Monterey, California 93940		10. PROGRAM ELEMENT, PROJECT, TASK AREA & WORK UNIT NUMBERS
14. MONITORING AGENCY NAME & ADDRESS (if different from Controlling Office)		12. REPORT DATE March 1979
		13. NUMBER OF PAGES 91
		15. SECURITY CLASS. (of this report) Unclassified
		15a. DECLASSIFICATION/DOWNGRADING SCHEDULE
16. DISTRIBUTION STATEMENT (of this Report)  Approved for public release; distribution unlimited.		
17. DISTRIBUTION STATEMENT (of the abstract entered in Block 20, if different from Report)		
18. SUPPLEMENTARY NOTES		
19. KEY WORDS (Continue on reverse side if necessary and identify by block number)		
20. ABSTRACT (Continue on reverse side if necessary and identify by block number)  Without a data base, unit commanders and training managers in the U. S. Army are left to plan their training based on what they perceive as their unit's weaknesses while analysis agencies are helpless to assist in providing meaningful direction to training efforts. With a data base drawn from ARTEP or SQT type evaluations, analysis agencies could model both the hardware parameters associated with equipment and		



the human parameters associated with unit or individual performance. Such modelling efforts could provide results which would be helpful in measuring the cost effectiveness trade-offs associated with various levels of unit or individual training.

The purpose of this study is to explore what data should be collected during Army training exercises in order to facilitate analysis through combat models. More specifically, this thesis will examine a Mechanized Infantry Platoon and Squad in the Active Defense and recommend measures of performance which are representative of the various functional areas which make up the Active Defense. Data representative of these measures of performance could then theoretically be used to accomplish analysis of training alternatives as previously discussed.



Approved for public release; distribution unlimited.

Measures of Performance for a  
Mechanized Infantry Platoon and  
Squad in the Active Defense

by

Roland Walter Carter  
Captain, United States Army  
B.S., United States Military Academy, 1970

Submitted in partial fulfillment of the  
requirements for the degree of

MASTER OF SCIENCE IN OPERATIONS RESEARCH

from the  
NAVAL POSTGRADUATE SCHOOL  
March 1979





## ABSTRACT

Without a data base, unit commanders and training managers in the U.S. Army are left to plan their training based on what they perceive as their unit's weaknesses while analysis agencies are helpless to assist in providing meaningful direction to training efforts. With a data base drawn from ARTEP or SQT type evaluations, analysis agencies could model both the hardware parameters associated with equipment and the human parameters associated with unit or individual performance. Such modelling efforts could provide results which would be helpful in measuring the cost effectiveness trade-offs associated with various levels of unit or individual training.

The purpose of this study is to explore what data should be collected during Army training exercises in order to facilitate analysis through combat models. More specifically, this thesis will examine a Mechanized Infantry Platoon and Squad in the Active Defense and recommend measures of performance which are representative of the various functional areas which make up the Active Defense. Data representative of these measures of performance could then theoretically be used to accomplish analysis of training alternatives as previously discussed.



## TABLE OF CONTENTS

I.	BACKGROUND - - - - -	6
II.	CHAPTER I: HOW MECHANIZED INFANTRY FIGHTS IN THE ACTIVE DEFENSE - - - - -	9
	A. INTRODUCTION - - - - -	9
	B. HOW THREAT FORCES ATTACK - - - - -	9
	C. THE ACTIVE DEFENSE - - - - -	12
	D. THE MECHANIZED PLATOON AND SQUAD IN THE ACTIVE DEFENSE - - - - -	15
III.	CHAPTER II: A FLOW CHART MODEL OF MECHANIZED INFANTRY IN THE ACTIVE DEFENSE - - - - -	23
	A. INTRODUCTION - - - - -	23
	B. METHODOLOGY - - - - -	23
	C. ORGANIZATION OF THE FLOW CHART MODEL - - - - -	24
IV.	CHAPTER III: RECOMMENDATIONS AND CONCLUSIONS - - - - -	36
	A. INTRODUCTION - - - - -	36
	B. CRITERIA FOR SELECTION OF MEASURES OF PERFORMANCE - - - - -	36
	C. RECOMMENDED MEASURES OF PERFORMANCE - - - - -	38
	D. CONCLUSIONS - - - - -	53
	APPENDIX A: THE FLOW CHART MODEL - - - - -	58
	BIBLIOGRAPHY - - - - -	90
	INITIAL DISTRIBUTION LIST - - - - -	91



## I. BACKGROUND

Training in the United States Army can be classified as either collective or individual. Collective training in the Army has been based on the Army Training and Evaluation Program (ARTEP) since 1975. On the other hand, individual training has been based on the Skill Qualification Test (SQT) since 1976. Both the ARTEP and SQT are performance oriented evaluations in which standards are set and units or individuals are evaluated on the basis of whether or not the established standards are met. Little, if any, data collection is actually performed in either the ARTEP or SQT and what data are collected is done solely to support the go/no-go evaluation of the unit or individual. Currently, there are no provisions for retaining collected data for future use by unit commanders, training managers or other training analysis activities.

Without a data base, unit commanders and training managers are left to plan their training based on what they perceive as their unit's weaknesses while analysis agencies are helpless to assist in providing meaningful direction to training efforts. With a data base drawn from ARTEP or SQT type evaluations, analysis agencies could model both the hardware parameters associated with equipment and the human parameters associated with unit or individual performance. Such modelling efforts could provide results which would be





helpful in measuring the cost effectiveness trade-offs associated with various levels of unit or individual training. Such analysis would help unit commanders establish their training priorities in a logical and orderly manner, based on analysis rather than perceived requirements. As a result, training assets (men, money, and time) would be used in a more cost effective manner. However, this can only be achieved if a meaningful data base exists for analysis agencies and unit commanders to work with.

The need for a data base developed from Army training evaluations seems clear and indeed has been recommended by a study conducted on the management of Army training.<sup>1</sup> The purpose of this thesis, however, is not to justify the need for data collection in the Army. Rather, the purpose here is to explore what data should be collected during Army training exercises in order to facilitate analysis through combat models. More specifically, this thesis will examine a Mechanized Infantry Platoon and Squad in the Active Defense and recommend measures of performance (MOPs) which are representative of the various functional areas which make up the Active Defense. Data representative of these MOPs could then theoretically be used to accomplish analysis of training alternatives as previously discussed.

---

<sup>1</sup>Gerding, R. L. and George, D. P., An Application of Organizational and Managerial Principles as an Improvement to the Current Army Training and Evaluation Program for the Mechanized Infantry, p. 71, Naval Postgraduate School, December 1978.



Chapter I of this thesis will explain and summarize how Mechanized Infantry fights in the Active Defense and specifically what is expected of a Platoon and Squad. Chapter II will present a Flow Chart model of a Mechanized Infantry Platoon in the Active Defense which identifies the tasks that must be accomplished and the responsible individual(s). Chapter III will, based on analysis of the Flow Chart model, recommend MOPs which, it is felt, accurately reflect the degree to which a Mechanized Infantry Platoon/Squad accomplishes its assigned mission in the Active Defense. In addition, Chapter III will briefly examine the feasibility of collecting data which is representative of the recommended MOPs based on existing training evaluation procedures and the findings of Gerding and George in their analysis of ARTEP management.



## II. CHAPTER I: HOW MECHANIZED INFANTRY FIGHTS IN THE ACTIVE DEFENSE

### A. INTRODUCTION

The defensive doctrine of the U. S. Army has undergone a radical change in the last five years. This change has been prompted by the realization that in all likelihood, U. S. forces in any future conflict will be forced to fight outnumbered. The proliferation of Threat forces, the increased lethality of modern weapons systems, and experience from the 1973 Mid-East War resulted in the adoption in 1976 of the Active Defense to replace the previous static defensive doctrine of the U. S. Army. Before examining the Active Defense more closely and determining what it requires of a Mechanized Infantry Platoon and Squad, an overview of how Threat forces attack will be presented.

### B. HOW THREAT FORCES ATTACK

Threat doctrine stresses the offense as the main element of combat and views the defense as a sometimes necessary but always temporary phase of combat. The concentrations of numerically superior forces and firepower for a combination of frontal attacks, enveloping maneuvers, and deep offensive thrusts into the enemy rear by armor heavy combined arms forces are the conceptual aims of the offense. Threat offensive doctrine is designed to support rapid and





aggressive offensive action that visualizes 30-50 kilometer advances per day in a conventional environment.<sup>2</sup>

Threat forces emphasize two basic forms of maneuver: the frontal attack and the envelopment. Envelopment is the preferred method of maneuver and is often conducted in conjunction with a frontal attack by forces of platoon size and larger. In advancing to contact, Threat forces strive to remain in column formation as long as possible to increase the speed of the advance. If possible, battalions will not deploy into battle formations until they are within 1 kilometer of the objective.<sup>3</sup>

Threat forces recognize three basic forms of offensive action: the meeting engagement, which includes advance to contact and hasty attack; the deliberate attack or breakthrough; and the pursuit. The meeting engagement normally follows an advance to contact and is characterized by actions to seize and maintain the initiative. The attack is carried out immediately from the line of march and may consist of a frontal attack, envelopment maneuver or both. A hasty attack is often an extension of the meeting engagement when prepared positions are encountered and Threat forces have located an assailable flank or gap in the defenses. During a hasty attack, the Threat Motorized Rifle Company attacks in line, usually behind an attached tank platoon and abreast of other motorized elements. Speed is stressed in the attack

---

<sup>2</sup>Department of the Army, FM 7-7, p. 5-3, 1977.

<sup>3</sup>Ibid., p. 5-5 - 5-7.



and riflemen remain mounted, fighting from their carriers, unless absolutely forced to dismount. Defending forces are destroyed or bypassed and mopped up by follow-on forces. If defending forces render a successful hasty attack impossible, Threat forces attempt to fix the defender for deployment of additional forces into a deliberate attack.<sup>4</sup>

The purpose of the deliberate attack or breakthrough is to rupture forward defenses to allow the passage of exploitation forces. The breakthrough operation is a frontal assault against prepared defenses where no gap or assailable flank is available. The breakthrough is characterized by the concentration of forces on a narrow front supported by massive amounts of artillery. A Threat company is assigned an immediate objective with a direction of further attack and has as its mission the destruction of a specific defending unit and/or the seizure of a ground objective.<sup>5</sup>

A Threat pursuit operation is intended to complete the destruction of a defending unit. Instead of following a retreating defender, Threat forces move on routes parallel to his movement attempting to outdistance him, cut the withdrawing column, and destroy the isolated element. Threat forces in the pursuit move in column formation for speed and bypass small pockets of resistance, trying to reach the flanks and rear of the main body, thus cutting off

---

<sup>4</sup> Ibid., p. 5-8.

<sup>5</sup> Ibid., p. 5-10.



the defender's route of withdrawal. The pursuit is initiated at the first opportunity by regiment and higher headquarters and is terminated only on orders from higher commanders.<sup>6</sup>

### C. THE ACTIVE DEFENSE

With Threat forces employing numerically superior forces and emphasizing such rapid, aggressive offensive techniques, the U. S. Army has adopted a defensive doctrine known as the Active Defense to counter the Threat offensive doctrine. The Active Defense requires defending units to engage the enemy at maximum range, withdraw and re-engage the enemy again at maximum range. Units become decisively engaged only when higher commanders perceive that so doing is absolutely critical to the success of the defense. These hit and move tactics are designed to buy time and attrit the enemy, while attempting to establish where the main enemy thrust is going to take place to allow the concentration of forces to block that attack. The battlefield for the Active Defense is organized into three main areas: the Covering Force Area (CFA); the Main Battle Area (MBA); and the Rear Area (RA).

The CFA is located forward of the MBA and has four basic objectives.

- Force the enemy to reveal the strength, location, and general direction of his main attack. To do this,

---

<sup>6</sup>Ibid., p. 5-12.





the Covering Force (CF) seeks contact with the enemy and engages with sufficient intensity to cause the enemy to deploy and reveal his main attack.

- Deceive or prevent the enemy from determining the strength, dispositions, and locations of friendly forces in the MBA.
- Divest the enemy of his air defenses or at least cause him to displace these forces before he attacks the MBA.
- Gain time for the main body to maneuver into and prepare its defenses in the MBA.<sup>7</sup>

Normally, armored cavalry units comprise the bulk of a force in the CFA with attached tank, mechanized infantry, engineers, artillery, and air defense units providing additional support. The CF is structured so as to convince the enemy that it has in fact met the main resistance of the friendly forces. Tank and mechanized infantry units used in the CF will also normally be used later in the MBA. The CF fights an indepth battle in the CFA attempting to achieve the four objectives described earlier, withdrawing to the MBA after a specified time period or on order of the CF commander.

The MBA lies behind the CFA and it is here that the main battle will be fought. The farther forward the fight is initiated in the MBA the better, allowing again for an in-depth fight from a succession of pre-selected battle positions which provide the defender with maximum attainable terrain advantage. The more penetration that the enemy

---

<sup>7</sup>Department of the Army, FM 100-5, p. 5-10.



achieves into the MBA, the more likely a breakthrough will be. However, the nature of the defense in the MBA is elastic by design. The defense is centered around tanks and Anti-Tank Guided Missiles (ATGMs) and relies on their early engagement of as many enemy tanks and personnel carriers as possible over a series of relatively short periods of time. When a commander has a "fire from mission" and perceives that he has inflicted as much damage as possible from his current battle position, he moves his unit (with his commander's permission) to a subsequent battle position to begin the engagement process all over again. Units located in battle positions on extremely critical terrain may receive "retain" missions which imply that they must be prepared to repel an enemy assault against their battle position. Such a mission is the exception rather than the rule because of the "in-elastic" nature of such a mission and the obvious danger of being bypassed.

The RA is the area behind the MBA from which supply and maintenance support are projected forward to the units in the MBA. Administrative echelons and communication centers are also located here. Because the RA is generally out of enemy artillery range, its main threat is from enemy air attack and airborne/air assault attacks. Friendly air defense units, airmobile infantry, and attack helicopter units are employed to protect the RA. Emphasis is also placed in the RA on concealment from air observation. However, large tank and mechanized infantry forces cannot be reserved to



protect the RA. To a large degree, support units in the RA are required to provide their own local security.

Thus, the Active Defense is what its name implies; a highly mobile defense that engages the enemy as soon as and as far forward as possible, followed by maneuvering to subsequent battle positions to start the engagement process over again. As the Active Defense progresses and the battle takes shape, higher commanders maneuver elements to block the enemy's main attack or shore up weaknesses in the MBA. At all costs, penetration of the MBA's rear boundary is prevented to preclude enemy breakthrough and pursuit operations into the RA.

#### D. THE MECHANIZED INFANTRY PLATOON AND SQUAD IN THE ACTIVE DEFENSE

The Mechanized Infantry plays a major role in the Active Defense by contributing to the tank killing potential of the force with their ATGMs and by providing close-in protection for tanks and ATGMs against dismounted infantry assaults by the enemy. While battalions and companies coordinate the Active Defense, it is the platoon and, more precisely, the squad that actually fights the battle. It is for this reason that the platoon and squad will be analyzed for tasks and MOPs in this thesis. Before these tasks can be examined in depth, it is important to understand the organization of the Mechanized Infantry Platoon/Squad and what the Active Defense requires of these units.

A Mechanized Infantry Platoon consists of four personnel carriers; one carrier for the Platoon Leader (PL) and one



carrier for each of the three squads in the platoon. Since the early 1960's, the M113 Armored Personnel Carrier (APC) has been the primary vehicle of the Mechanized Infantry. The APC affords only limited armor protection for the squad and has a .50 Caliber machinegun as its main weapon. It is lacking in mobility and the squad cannot fight from the vehicle with any degree of protection. The APC is soon to be replaced by the Infantry Fighting Vehicle (IFV) which is a dramatic change from the APC. The IFV has increased mobility and mounts a 25mm Bushmaster cannon as its main weapon, along with a TOW missile launcher and a co-axially mounted 7.62mm machinegun. This marked increase in firepower is mounted on a stabilized two man turret which greatly enhances the effectiveness of these weapons. With a total of six firing ports located on the sides and rear of the IFV, the squad can now fight from their vehicle without exposing themselves to the enemy. For the purpose of this thesis, the IFV will be treated as the primary vehicle for the Mechanized Infantry Squad. Figure 1-1 provides a detailed description of the weapons available to a squad mounted on the IFV. Figure 1-2 describes the proposed squad organization for the IFV and interior configuration of the vehicle. This is the organization which will be used for the Mechanized Infantry Squad in this thesis.

Mechanized Infantry Platoons/Squads fight the Active Defense through accomplishment of the following:





WEAPONS AVAILABLE TO THE IFV SQUAD

<u>WEAPON</u>	<u>DESCRIPTION</u>
TOW.....	The TOW is an optically sighted, wire guided anti-tank weapon. The IFV carries a TOW launcher that holds two TOWs for firing. Additionally, up to five more TOWs can be stowed in the carrier itself. The TOW mounted on the IFV can destroy tanks and personnel carriers at ranges beyond 3000 meters. It can be fired by either the IFV Commander (Squad Leader or Platoon Leader) or the Gunner.
Bushmaster.....	The Bushmaster is a 25mm automatic cannon which fires both High Explosive (HE) and Armor Piercing (AP) ammunition. The Bushmaster mounted on the IFV can destroy personnel carriers using AP ammunition at ranges beyond 2000 meters. Using HE ammunition, it can kill or suppress personnel at similar ranges. The Bushmaster has 300 rounds in the "ready" position and 600 rounds in the "stowed" position. The Bushmaster is considered to be the primary weapon on the IFV and like the TOW, it can be fired by the IFV Commander or the Gunner.
COAX MG.....	The COAX is a 7.62mm machinegun which is co-axially mounted with the Bushmaster. Used either as a spotting weapon for the Bushmaster or against personnel in the open, it has 800 rounds in the "ready" position and 1400 rounds in the "stowed" position. It too can be fired by either the IFV Commander or the Gunner.
M60 MG.....	The M60 is a belt-fed, gas operated, automatic machinegun which can be fired from either an attached bipod mount or a separate tripod mount. Effective at ranges up to 600 meters for point targets and 1100 meters for area targets, it is fired by the Machine Gunner while dismounted from the IFV. A total of 2200 7.62mm rounds of ammunition for the M60 MG are carried on the IFV.

Figure 1-1



WEAPONDESCRIPTION

Dragon.....The Dragon is a man-portable, shoulder fired, medium anti-tank weapon. The Dragon consists of two major components: a tracker and a round. The round, consisting of the launcher and missile, is expendable; the tracker is re-usable and designed for fast, easy detachment from the round. The Dragon can destroy tanks and personnel carriers at ranges between 65 meters and 1000 meters. It is fired by the Dragon Gunner while dismounted from the IFV. Up to five Dragon rounds can be stowed on the IFV.

Dual Purpose Weapon...The Dual Purpose Weapon consists of the M203 40mm grenade launcher attached to a M16A1 rifle. The grenade launcher is a single shot, breach loaded weapon which fires a variety of ammunition. It has the ability to penetrate armor plating and bunkers, suppress or kill personnel, illuminate, and signal depending upon the choice of ammunition. Primarily used to neutralize and suppress targets that are in dead spaces of gracing fire weapons, it is effective at ranges up to 350 meters against area targets and 200 meters against point targets. It is fired by the Grenadier while dismounted from the IFV. Information on the M16A1 rifle is presented below.

LAW.....The LAW (Light Anti-Tank Weapon) is a self contained weapon consisting of a 66mm HEAT (High Explosive Anti-Tank) rocket. It weighs only 5.2 lbs. but can defeat more than 20 centimeters of armor plating. Used against tanks, personnel carriers, and bunkers, it is effective at ranges up to 200 meters. The carrying case is disposable and is destroyed after using. There are three LAWs stowed in an IFV. There is no designated gunner for the LAW; rather, all members of the squad are required to be qualified in its use.

Figure 1-1 (continued)



WEAPON

DESCRIPTION

M16A1 Rifle.....The M16A1 rifle is a 5.56mm weapon which is magazine-fed, gas operated and shoulder fired. It can be fired from either the automatic or semi-automatic mode. Both 20 and 30 round magazines are available for the M16A1. It is effective at ranges up to 350 meters. All personnel in the IFV squad (except the M60 Machine Gunner) are armed with the M16A1. A total of 2160 5.56mm rounds are stowed on the IFV.

Firing Port Weapon....The Firing Port Weapon is a 5.56mm rifle mounted inside the IFV. Two are located on either side of the IFV and two are located on the rear of the IFV. Used primarily in offensive action during a mounted assault, the Firing Port Weapon gives the squad the ability to engage targets while protected inside the IFV. All squad members except the Driver, Gunner, and Squad Leader man the Firing Port Weapons. A total of 1800 rounds are in the "ready" position and an additional 2200 rounds are stowed aboard the IFV.

Figure 1-1 (continued)



ORGANIZATION AND CONFIGURATION OF  
A MECHANIZED INFANTRY SQUAD IN AN IFV

<u>POSITION NUMBER</u>	<u>SQUAD MEMBER</u>
1	Driver
2	Gunner
3	Squad Leader
4	Rifleman
5	Rifleman
6	Grenadier
7	Grenadier
8	Machine Gunner
9	Machine Gunner

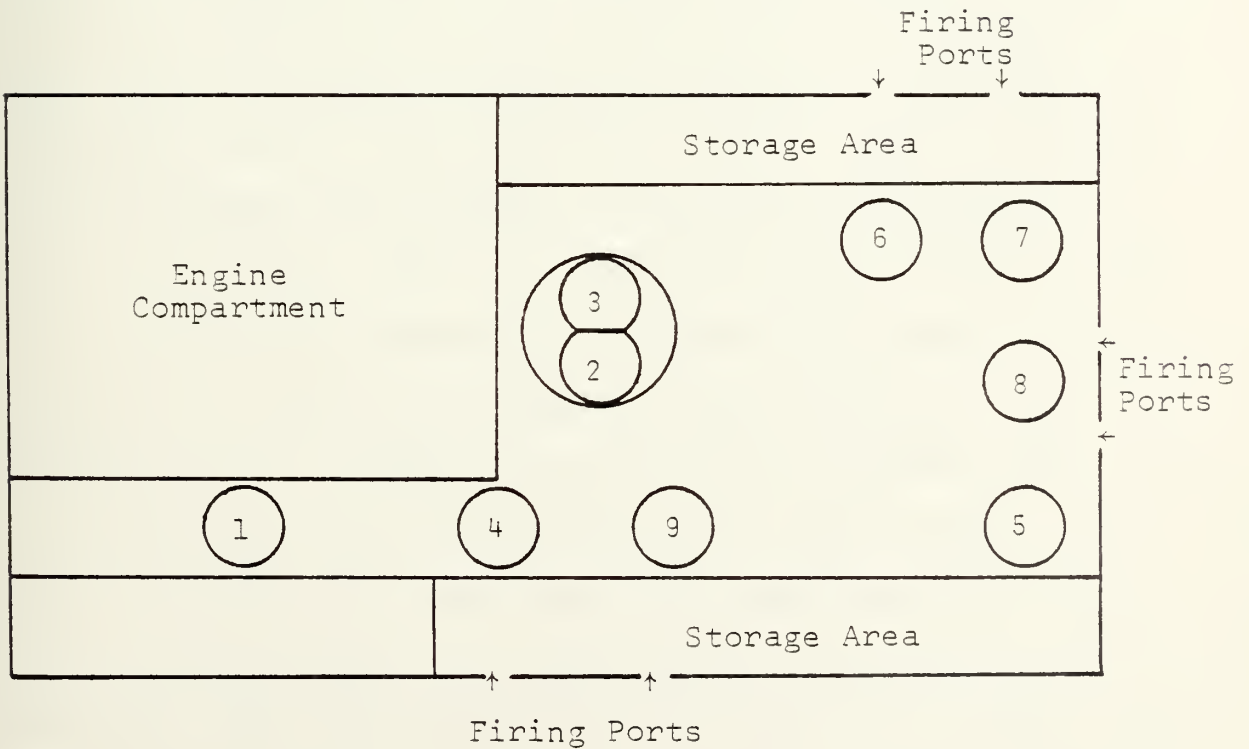

Figure 1-2





- Destroying the enemy in designated sectors of fire with TOW, Bushmaster, Dragon, LAW, and machinegun fire, supplementing the fire of tanks and other ATGMs.
- Repelling mounted attacks on avenues of approach which cannot be adequately covered with ATGM and tank fire.
- Repelling dismounted infantry assaults.
- Protecting ATGMs and tanks from enemy infantry, especially when visibility is limited.
- Constructing obstacles to slow or canalize the enemy.

Within a battle position, the platoon's IFVs are located so as to provide the opportunity to engage the enemy with TOW and Bushmaster at the longest possible range. IFVs are located in either "hull down" firing positions or "hide" positions. Hull down firing positions afford a covered and concealed location from which the IFV can fire its weapons, thus minimizing the exposure of the super structure of the IFV to the enemy. When such a position does not exist, the IFV is placed in a covered and concealed hide position with an observer located in a forward firing position. When the observer spots a target, he calls the IFV forward, the target is engaged, and the IFV returns to its hide position. Dismounted infantry are positioned to provide the best protection for IFVs, tanks, and ATGMs against dismounted infantry assaults. With the Dragon and LAW, dismounted infantry also have the ability to kill enemy tanks and personnel carriers at ranges up to 1 kilometer. This capability is also given



careful consideration when dismounted infantry are positioned. These positioning considerations often require that the dismounted squad and the IFV be in different locations, but not so far apart that rapid movement out of the battle position cannot be accomplished.

There are three basic types of fighting positions in a battle position; primary fighting positions (PFPs), alternate fighting positions (AFPS), and supplemental fighting positions (SFPs). Mounted and dismounted PFPs are located to cover the unit's primary sector of fire. AFPs also cover the unit's primary sector of fire and are occupied when PFPs (or other AFPs) become untenable. SFPs are located to cover a unit's secondary sector of fire. Dismounted infantry will normally have one PFP, one SFP, and at least one AFP. IFVs will normally have one PFP, one SFP, and at least two AFPs. Movement from a PFP to an AFP allows a unit to remain in a battle position and fire into its primary sector of fire even though its PFP may be receiving effective fire from the enemy. Movement to an SFP is made to counter an attack from a direction other than the primary one anticipated when the fighting positions were initially sited.

The aggressive tactics of the enemy, the highly mobile nature of the Active Defense, and the wide variety of weapons available to the Mechanized Infantry Platoon/Squad present a formidable challenge to the Platoon Leader and the Squad Leader, and represent a complex set of tasks which must be accomplished. Precisely what these tasks are and how they fit into the Active Defense is the topic of the next Chapter.



### III. CHAPTER II: A FLOW CHART MODEL OF MECHANIZED INFANTRY IN THE ACTIVE DEFENSE

#### A. INTRODUCTION

As already discussed, the Mechanized Infantry Squad equipped with the IFV in the Active Defense must fight a mobile battle, constantly striving to engage the enemy at as long a range as possible. The purpose of this Chapter is to determine the specific tasks that must be accomplished by a Mechanized Infantry Platoon/Squad during the course of an Active Defense battle. However, before these tasks are delineated, the methodology used to identify them will be explained.

#### B. METHODOLOGY

The methodology used to identify the tasks required of a Mechanized Infantry Platoon/Squad was to flow chart the activities of a Platoon/Squad in the Active Defense. In so doing, it was possible to identify specifically what tasks had to be accomplished and which personnel were responsible for a given task. In flow charting the Active Defense, the intent was to develop a general model which would consider all possible tasks and courses of action. The Flow Chart model was not intended to prioritize tasks nor develop a specific sequence of occurrence for tasks.

Within the flow chart itself, six symbols are used. These symbols and an explanation of their meanings are



presented in Figure 2-1. Figure 2-2 explains the abbreviations that are used throughout the flow chart. The most important symbol used in the flow chart is the square which represents a task. The person(s) responsible for a given task is identified in the lower right hand corner of the respective square. Development of the flow chart was based on current Army doctrine for the Active Defense as described in FM 100-2, FM 71-1, and FM 7-7. An Army Research Institute study [Ref. 9] concerning the tasks required of an IFV crew was also a primary reference for the development of the flow chart.

#### C. THE FLOW CHART MODEL OF THE ACTIVE DEFENSE

The Active Defense can generally be classified into three Phases:

- Occupy Battle Positions
- Engage Enemy
- Consolidate or Move Out of Battle Position

Each of these Phases has a number of Components or functional areas associated with it. These Components are broken out among the three Phases as follows:

##### Occupy Battle Position Phase

- Move to Battle Position
- Move into Battle Position
- Prepare Fighting Positions
- Create Obstacles
- Prepare Fire Plan





## FLOW CHART SYMBOLS

### SYMBOL

### EXPLANATION



Represents a Task



Represents a Component on the Master Chart



Coordination Symbol. All Tasks leaving this symbol occur simultaneously. All Tasks coming into this symbol must be complete before any Task can leave. Some are numbered or lettered for reference purposes.



Task Connectors. Arrows indicate direction to next Task.

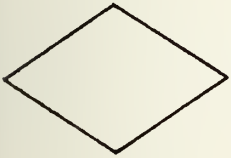

Administrative Symbol. Used to control the flow of Tasks and/or answer questions generated by the Tasks.



Page Connector. Identifies Task Connectors that are split between pages. Lettered for reference purposes.

Figure 2-1



ABBREVIATIONS USED IN THE FLOW CHART MODEL

<u>ABBREVIATION</u>	<u>EXPLANATION</u>
AFP	Alternate Fighting Position
AMMO	Ammunition
AOA	Avenue of Approach
ASEQ	Acquisition Sequence
AVAIL	Available
BDNG	Bounding
BDNG.OW	Bounding Overwatch
BET	Between
BM	Bushmaster
BMSEQ	Bushmaster Sequence
BP	Battle Position
CAMFLGE	Camouflage
CM	Claymore Mine
Co. CDR	Company Commander
COAX SEQ	COAX Machinegun Sequence
Co-LOC	Co-Located
CONT	Continue
CSEQ	Communication Sequence
CP	Command Post
D	Driver
DES	Designate
DEST	Destroyed
DESTN	Destination
DET	Determine

Figure 2-2



ABBREVIATIONEXPLANATION

DF	Direct Fire
DG	Dragon Gunner
DIR	Direct
DIST	Distribute
DMSEQ	Dismounted Movement Sequence
DMTD	Dismount/Dismounted
DPW	Dual Purpose Weapon
DPW SEQ	Dual Purpose Weapon Sequence
DRAGON SEQ	Dragon Sequence
DSM	Designated Squad Member
ELMNT	Element
EMPL	Emplace/Emplaced
ENG	Engage
EQUIP	Equipment
EVAC	Evacuate
FO	Forward Observer
FP	Fighting Position
FPF	Final Protective Fire
FPW	Firing Port Weapon
FPL	Final Protective Line
G	Gunner
GD	Grenadier
HD	Hull Down
HMF	Hasty Minefield
HP	Hide Position

Figure 2-2 (continued)



<u>ABBREVIATION</u>	<u>EXPLANATION</u>
HQs	Headquarters
IDF	Indirect Fire
IDF SEQ	Indirect Fire Sequence
IFV	Infantry Fighting Vehicle
ILLUM	Illumination
INFO	Information
INTEL	Intelligence
LAW	Light Anti-Tank Weapon
LAW SEQ	Light Anti-Tank Weapon Sequence
LG	LAW Gunner
LOS	Line of Sight
MG	M60 Machine Gunner
MMSEQ	Mounted Movement Sequence
MSG	Message
MSGR	Messenger
MTD	Mounted
MVMT	Movement
M60 SEQ	M60 Machinegun Sequence
OB	Observer
OBS	Observation
OBSCUR	Obscure
OHC	Overhead Cover
OP-LP	Observation Post-Listening Post
OPRN	Operation

Figure 2-2 (continued)





<u>ABBREVIATION</u>	<u>EXPLANATION</u>
PFP	Primary Fighting Position
PH	Personal Hygiene
PL	Platoon Leader
PLT	Platoon
POSN	Position
POWs	Prisoners of War
PREP	Prepare
P/S	Primary/Secondary
PSG	Platoon Sergeant
R	Rifleman
REPL	Replace
REPLTS	Replacements
RLS	Radio Listening Silence
SFP	Supplemental Fighting Position
SL	Squad Leader
SM	Squad Member
SOF	Sector of Fire
SQD	Squad
SUP	Suppressed
TECH	Technique
TC	Track Commander
TF	Trip Flare
TGT	Target
TM	Team
TOW SEQ	TOW Sequence

Figure 2-2 (continued)



ABBREVIATIONEXPLANATION

TRP	Target Reference Point
TRVL.OW	Travelling Overwatch
UGS	Unattended Ground Sensors
VS	Visual Signal
WPNS	Weapons

Figure 2-2 (continued)



- Establish Security
- Maintain Security
- Continue to Prepare Fighting Positions
- Prepare Future Battle Positions
- Conduct Sustaining Operations

#### Engage Enemy Phase

- Engage Enemy Long Range (greater than 2500 meters)
- Engage Enemy Mid Range (1000-2500 meters)
- Engage Enemy Short Range (less than 1000 meters)

#### Consolidate or Move Out of Battle Position Phase

- Consolidate
- Move Out of Battle Position

Figure 2-3 is a Master Chart of the three phases of the Active Defense and their associated Components. Each Component represents a separate flow chart which specifically develops the tasks associated with that Component. In addition to these Component flow charts, a number of Sequences were developed separately. These Sequences represent a series of tasks which occur repeatedly throughout the flow charts. These Sequences are presented separately in an attempt to simplify the Component flow charts. These Sequences include:

- Mounted Movement Sequence
- Dismounted Movement Sequence
- Communication Sequence
- Acquisition Sequence
- TOW Sequence
- Bushmaster Sequence
- LAW Sequence



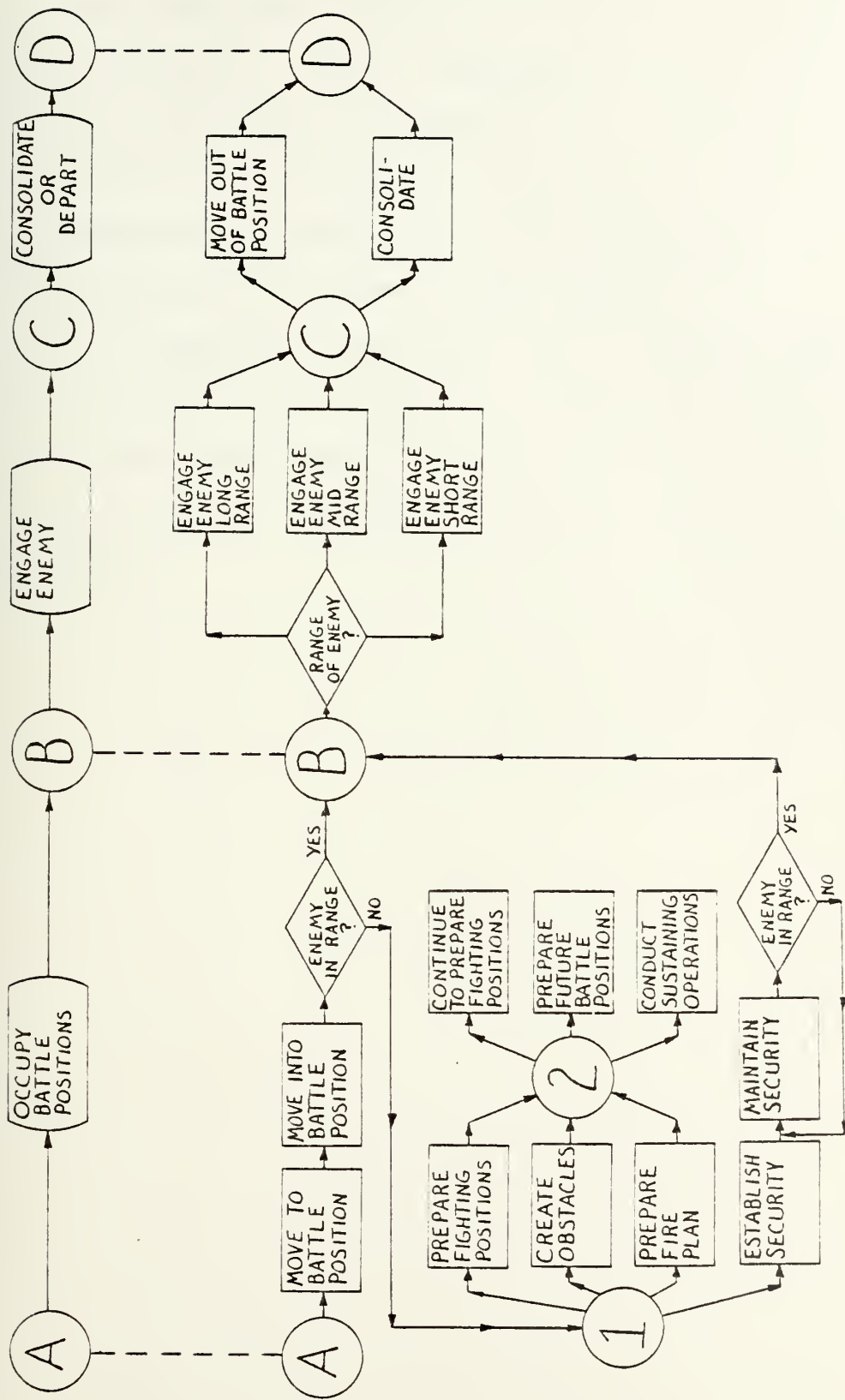

Figure 2-3 (Master Chart)





- Dragon Sequence
- M60 Machinegun Sequence
- Dual Purpose Weapon Sequence
- COAX Machinegun Sequence
- Indirect Fire Sequence
- Movement to Dismounted AFP/SFP Sequence
- Movement to Mounted AFP/SFP Sequence

The 15 Component flow charts and 14 Sequence flow charts which represent the Mechanized Infantry Platoon/Squad in the Active Defense are listed in Appendix A. Figure 2-4 contains an index of Figure numbers for the flow charts contained in Appendix A.



INDEX OF FLOW CHART FIGURE NUMBERS  
IN APPENDIX A

<u>FIGURE NUMBER</u>	<u>COMPONENT</u>
Figure A-1	Move to Battle Position
Figure A-2	Move Into Battle Position
Figure A-3	Prepare Fighting Positions
Figure A-4	Create Obstacles
Figure A-5	Prepare Fire Plan
Figure A-6	Establish Security
Figure A-7	Maintain Security
Figure A-8	Continue to Prepare Fighting Positions
Figure A-9	Prepare Future Battle Positions
Figure A-10	Conduct Sustaining Operations
Figure A-11	Engage Enemy Long Range
Figure A-12	Engage Enemy Mid Range
Figure A-13	Engage Enemy Short Range
Figure A-14	Consolidate
Figure A-15	Move Out of Battle Position

<u>FIGURE NUMBER</u>	<u>SEQUENCE</u>
Figure A-16	Mounted Movement
Figure A-17	Dismounted Movement
Figure A-18	Communication
Figure A-19	Acquisition
Figure A-20	TOW

Figure 2-4



<u>FIGURE NUMBER</u>	<u>SEQUENCE</u>
Figure A-21	Bushmaster
Figure A-22	LAW
Figure A-23	Dragon
Figure A-24	M60 Machinegun
Figure A-25	Dual Purpose Weapon
Figure A-26	COAX Machinegun
Figure A-27	Indirect Fire
Figure A-28	Movement to Dismounted AFP/SFP
Figure A-29	Movement to Mounted AFP/SFP

Figure 2-4 (continued)



#### IV. CHAPTER III: RECOMMENDATIONS AND CONCLUSIONS

##### A. INTRODUCTION

The flow charts presented in Appendix A reveal the relationship of tasks and decisions which, when taken together, comprise the Active Defense. The purpose of the Flow Chart model, as mentioned earlier, was to identify those critical tasks and decisions which significantly influence unit performance in various functional areas (Components and Sequences) so that data could be collected to assist a combat modeller in representing these functional areas. Before reviewing the recommended MOPs, an explanation of the "ground rules" for their selection is appropriate.

##### B. SELECTION CRITERIA FOR MEASURES OF PERFORMANCE

In the context of the Flow Chart model, a measure of performance can best be defined as an indicator which reflects the degree to which prescribed Components and Sequences are accomplished. They are ideally, but not always, quantifiable and they should directly relate to the Component/Sequence in question. The combat modeller is interested in MOPs which can serve as, or support, input parameters to a model. The model produces output in the form of pre-determined measures of effectiveness (MOEs) which enable the modeller and decision maker to make conclusions about the system in question. For the purpose of this thesis, the "system" was a Mechanized





Infantry Platoon/Squad and the MOPs sought were measures which represent this system's performance in the Active Defense.

In analyzing the Components and Sequences of the Flow Chart model for MOPs, the following criteria were used:

- The MOP had to have a significant impact on the Platoon/Squad's ability to accomplish the objective of the Component/Sequence under consideration.

- The MOP had to be of interest to a combat modeller trying to model the Component/Sequence in question.

If a MOP could not meet these two criteria, it was not recommended. It is important to mention that no consideration was given to the "measurability" of the MOP, i.e., could data in fact be gathered which would be representative of the MOP. This topic was beyond the scope of this thesis and should constitute the next step in this research effort. The purpose here was to simply identify those MOPs, within the guidelines mentioned, which represent the performance of a Mechanized Infantry Platoon/Squad in the Active Defense.

The MOPs identified can generally be classified as representing either time, accuracy or decision criteria. Time and accuracy are variables which are generally quantifiable; decision criteria, on the other hand, are not readily quantifiable but of no less importance to the combat modeller. Because of the multitude of decisions required in an Active Defense battle, many of the recommended MOPs fall into this category. Whereas time and accuracy can generally be



represented numerically (time to engage, missed distance, etc.), decision criteria are normally described by a list of factors influencing the decision which, in turn, may be weighted to reflect their relative importance. For example, a decision criteria for route selection could be composed of those factors used in selecting a route (range of enemy, terrain, vegetation, available intelligence, etc.) and their relative importance obtained through sampling of those Platoon/Squad members involved in making such decisions. With this type of information, the combat modeller will be in a much better position to represent the dynamic action inherent in operations such as the Active Defense.

#### C. RECOMMENDED MEASURES OF PERFORMANCE

The recommended MOPs are presented in this section by Component/Sequence category as described in the Flow Chart model. Where appropriate, a brief comment concerning the Component/Sequence or recommended MOP(s) follows the listing of the recommendations. In particular, MOPs which do not fall into one of the three major categories previously mentioned will be discussed.

##### COMPONENT: Move to Battle Position

- Time required for a Squad Leader to issue an order to his Squad.
- Decision criteria for selection of a movement technique.
- Decision criteria for action (seek cover or continue to move) when receiving indirect fire.



The indepth nature of the Active Defense results in the appearance of this Component repeatedly throughout a battle. Although the Sequences referenced in this Component provide additional MOPs, the three listed above should also receive consideration by a combat modeller because of their impact on the overall performance of the Platoon/Squad.

COMPONENT: Move Into Battle Position

- Time required for a Platoon Leader and his Squad Leaders to conduct a dismounted reconnaissance of a battle position.

- Decision criteria for selection of mounted and dismounted primary fighting positions.

- Decision criteria for selection of primary and secondary sectors of fire for the dismounted Squad and the IFV.

- Time required to position a Platoon in a battle position when the enemy is in range and when the enemy is not in range.

The last MOP listed above may be the most significant in this Component. The degree to which a Platoon can or cannot perform in this area will greatly influence its ability to engage the enemy as far forward as possible.

COMPONENT: Prepare Fighting Positions

- Time required for a Squad to dig fighting positions with overhead cover and without overhead cover.

- Percentage of fighting positions in a Platoon size battle position that are visible from various ranges in



front of the battle position and from the air.

- Time required to clear fields of fire.

- Time required to camoflauge mounted and dismounted fighting positions.

- Decision criteria for selection of mounted and dismounted alternate fighting positions and supplemental fighting positions.

The ability of a Platoon to prepare its fighting positions will directly influence its survivability in the battle and, as a result, the eventual outcome of the battle. In particular, the presence of overhead cover has been shown to be of major importance to the survival of dismounted infantry receiving the volume of indirect fire that can be expected from Threat forces.<sup>8</sup> Because of this, these MOPs are seen as critical in any effort to model Mechanized Infantry in the Active Defense.

COMPONENT: Create Obstacles

- Decision criteria for site selection (including size and density) for claymore mines, hasty minefields, and wire obstacles.

- Percentage of claymore mines and hasty minefields visible from inspection of the obstacle site (from enemy's side).

- Distribution of error in recording claymore mine and hasty minefield locations.

---

<sup>8</sup>Chaudrue, R. G. (LTC), "Requiem for the Infantry," Infantry Magazine, p. 29, May-June 1978.





- Decision criteria for employment of claymore mines, hasty minefields, and wire obstacles.

- Time required to camouflauge claymore mines, hasty minefields, and wire obstacles.

COMPONENT: Prepare Fire Plan

- Decision criteria for selection of final protective lines for M16A1 and M60 Machinegun firers.

- Decision criteria for selection of primary and secondary sectors of fire for dismounted weapons.

- Decision criteria for the selection of target reference points.

- Percentage of actual deadspace in a Squad sector that is identified and covered by indirect fire.

Of all the Components in the Flow Chart model, Prepare Fire Plan may be of least interest to a modeller concerned with the Mechanized Infantry Platoon/Squad in the Active Defense because fire planning (especially indirect fire) is normally controlled and organized at Company and higher levels. However, determination of deadspace is of importance to the planning of fires and the Squad and Platoon are the level at which the deadspace is found and reported to Company and higher levels for use in indirect fire planning. Consequently, the combat modeller should not totally ignore this Component of the Active Defense.

COMPONENT: Establish Security

- Decision criteria for employment of unattended ground sensors (UGS), trip flares (TFs), commo wire, and observation



posts - listening posts (OP-LPs).

- Decision criteria for the selection of sites for UGS, TFs, and OP-LPs.

- Time required to camouflauge UGS and TFs.

- Percentage of UGS and TFs visible from inspection of a site (from enemy's side).

- Time required for a Platoon to establish a communications hot loop.

- Time required for a Squad member(s) to emplace UGS and TFs.

- Time required for a Squad to establish an OP-LP.

COMPONENT: Maintain Security

- Percentage of UGS and TF activations that are not detected.

- Distribution of operator error in pinpointing a target location resulting from an UGS activation.

- Time required for a Platoon to man its fighting positions when told to do so.

This Component, as well as its predecessor, is important because it often determines the range at which the enemy is initially engaged. Because of this, unit commanders traditionally emphasize this Component and modellers must be able to represent its affect on the combat outcome.

COMPONENT: Continue to Prepare Fighting Positions

- Decision criteria for digging in wire, providing overhead cover, digging trenches between fighting positions, and digging in IFVs.



- Time required for a Squad to dig trenches between dismounted fighting positions.

- Time required for an IFV to be dug in.

COMPONENT: Prepare Future Battle Positions

- Decision criteria for determining the order of preparation for future battle positions.

Although Platoons and Squads are involved in this Component, the particular MOP listed above is usually a decision which is made at a higher level. Nevertheless, the combat modeller should have access to information influencing this decision during the Active Defense at the Platoon/Squad level.

COMPONENT: Conduct Sustaining Operations

- Time required for a Driver to perform first echelon maintenance on an IFV.

- Time required for a Squad to clean its dismounted weapons.

- Time required for a Gunner to clean a Bushmaster.

- Reliability of weapons and IFVs.

- Percentage of weapons and IFVs that fail to operate because of poor operator maintenance or cleaning.

The fourth MOP concerns the reliability of weapons and the IFV when they are in the hands of troops. The fifth MOP concerns the number of malfunctions of weapons and IFVs that can be attributed to poor operator maintenance or cleaning. These are both very valuable MOPs to a combat modeller but they are also extremely hard to measure. The fifth MOP in particular would require knowing why a vehicle



or weapon failed to operate in order to determine if the operator was responsible.

COMPONENT: Engage Enemy Long/Mid/Short Range

- Decision criteria for the re-call of an OP-LP.
- Decision criteria for moving a Squad to a dismounted supplemental fighting position.
- Decision criteria for moving a Squad to a dismounted alternate fighting position.
- Decision criteria for moving an IFV to a supplemental fighting position.
- Frequency with which an attacker can pinpoint a defender's firing position.
- Distribution of aim error of an attacker given that the defender has been pinpointed.
- Decision criteria for occupying dismounted fighting positions.

The decision criteria for moving an IFV to an alternate fighting position is not mentioned here because it falls under the TOW SEQ and BMSEQ. The fifth and sixth MOPs listed above concern an attacker's ability to pinpoint a defender's position as a result of the defender firing from his position. Combat models usually allow for visual acquisition and "pinpoint" detections. Pinpointing involves the location of a position as a result of muzzle blast, firing signature, noise or any other signature effect produced by the firing of a weapon. This phenomena is particularly important with the TOW and Dragon because of their pronounced firing signatures.





The combat modeller must have some type of information with which to model the pinpoint type of acquisition and these two MOPs are intended to provide that information. The last MOP listed above is not specifically addressed in the Flow Chart model. While doctrine generally states that the Squad will always prepare fighting positions, precisely when, during the course of a battle, the Squad occupies these positions is not clear. Such a decision is likely a function of unit mission, range of the enemy, and the dismounted Squad's ability to contribute to the battle. This MOP is included because of the need to model this aspect of the Active Defense.

COMPONENT: Consolidate

- Time required to redistribute ammunition within a Squad.

COMPONENT: Move Out of Battle Position

- Time required for a dismounted Squad to mount an IFV.
- Miss distance with firing port weapons against moving and stationary targets (IFV moving and stationary).
- Range of the enemy when movement out of a battle position is initiated.

The first MOP listed above includes the time required for the IFV to move to the pick up point where the dismounted Squad will mount. Although not mentioned above, the combat modeller is concerned with the decision criteria for moving out of a battle position. This is largely mission and situation dependent and is a decision made at Company level or higher.



SEQUENCE: Mounted Movement (MMSEQ)

- Time required for an IFV to move to a specific location, a specified distance away.

- Frequency with which a specific destination is not reached by mounted movement due to navigational error (within a prescribed tolerance).

- Decision criteria for the selection of a mounted route.

SEQUENCE: Dismounted Movement (DMSEQ)

- Time required for a Squad member to move to a specific location, a specific distance away.

- Frequency with which a specific destination is not reached by dismounted movement due to navigational error (within a prescribed tolerance).

- Decision criteria for the selection of a dismounted route.

The first MOP listed above would serve to show the driver's contribution to the movement time of a vehicle. Combat models that have movement routines use very detailed data (vehicle specifications, soil trafficability, slope speeds, etc.) to compute movement times. The first MOP would provide a means of determining what the driver does or does not contribute to the movement time of the vehicle.

SEQUENCE: Communication (CSEQ)

- Time required to send a message by wire, radio, messenger, and visual signal.

- Time required for a radio transmission.



- Frequency with which a message is not understood when sent by wire, radio, messenger, and visual signal.

- Frequency with which communication cannot be established by wire, radio, and messenger.

Virtually every Component and Sequence in the Flow Chart model contains at least one CSEQ. If a Platoon/Squad cannot communicate in the Active Defense, its ability to contribute to the battle will be greatly reduced. Little is currently known about the communications process within a Platoon/Squad. A better understanding of the above MOPs and their inter-relationships should lead to more effective unit actions.

SEQUENCE: Acquisition (ASEQ)

- Time required for a Squad member to acquire a target, given that intervisibility exists.

- Percentage of time that a Squad member engages an infeasible target, as described below.

- Time required for a Squad member to identify a target, given acquisition.

- Frequency of search by a Squad member for a given sector.

The MOPs listed above concern all members of a Squad because at one time or another, they all go through this Sequence. For obvious reasons though, these MOPs are more critical for the Squad Leader and Gunner (and Observer in the case of an IFV hide position) because they fire the TOW and Bushmaster, or influence it in the case of an Observer. An infeasible



target is operationally defined to be a target which is thought to be in range for a particular weapon but actually is not. For example, if a Gunner tries to engage an enemy tank at 4000 meters, the tank is considered to be an infeasible target. Although shown in this Sequence within the Flow Chart model, the task concerning target selection when multiple targets are available is discussed under the various weapon Sequences.

SEQUENCE: TOW (TOW SEQ)

- Time required for an Observer to call an IFV forward from a hide position and pass off the target. (This MOP is also applicable to, but not listed under, the Bushmaster Sequence.)

- Decision criteria for target selection when more than one TOW target is available.

- Miss distance of TOW against moving and stationary targets.

- Time required to re-arm the TOW launcher (one and two rounds).

- Number of rounds fired by a TOW before displacement.

- Decision criteria for moving an IFV to an alternate fighting position. (This MOP is also applicable to, but not listed under, the Bushmaster Sequence.)

- Decision criteria for re-engaging a TOW target that has already been missed.

- Sensing error involved in determining if a target has been hit by a TOW firing.





Because of the firing "signature" of a TOW, the MOPs concerning what constitutes an untenable fighting position and multiple engagements are very important to the combat modeller. Sensing error, mentioned in the last MOP, concerns the firer's ability to determine if he has hit a target. This is not peculiar to the firing of a TOW and is mentioned in several other Sequences. The difficulty in making this determination varies from weapon to weapon. This is a very realistic MOP which grows in importance as the number of targets and clutter on the battlefield increase.

SEQUENCE: Bushmaster (BMSEQ)

- Time required to re-load a Bushmaster (BM) with AP and HE ammunition.
- Sensing error involved in determining if a target was hit by a BM firing (with both AP and HE ammunition).
- Miss distance of center of burst for BM firing HE ammunition against moving and stationary targets (IFV moving and stationary).
- Miss distance of BM firing AP ammunition against moving and stationary targets (IFV moving and stationary).
- Number of bursts fired with a BM from a given fighting position before displacement.
- Decision criteria for target selection when both mounted and dismounted BM targets are available.
- Decision criteria for re-engaging a BM target that has already been missed.



SEQUENCE: Light Anti-Tank Weapon (LAW SEQ)

- Time required for a Squad member to place a LAW in operation.
- Miss distance with the LAW against moving and stationary targets.
- Decision criteria for re-engaging a LAW target that has already been missed.
- Decision criteria for target selection when more than one LAW target is available.
- Number of LAWs fired from a specific fighting position before displacement.
- Sensing error involved in determining if a target was hit by a LAW.

SEQUENCE: Dragon (Dragon SEQ)

- Time required for a Dragon Gunner to remove the Dragon tracker from a used missile and place it on a new missile.
- Miss distance with a Dragon against moving and stationary targets.
- Decision criteria for target selection when more than one Dragon target is available.
- Number of Dragon rounds fired before displacement.
- Sensing error involved in determining if a target was hit by a Dragon firing.

SEQUENCE: M60 Machinegun (M60 SEQ)

- Miss distance of a burst from a M60 machinegun against moving and stationary targets.
- Time required for a Machine Gunner to re-load a M60 machinegun.



- Decision criteria for target selection when more than one M60 target is available.

- Number of bursts required to hit a target.

- Time delay between the signal for final protective fire (FPF) and the firing of the M60 FPF.

- Sensing error involved in determining if a target was hit by a M60 machinegun burst.

SEQUENCE: Dual Purpose Weapon (DPW SEQ)

- Miss distance of M203 Grenade Launcher against moving and stationary targets.

- Miss distance of M16A1 against moving and stationary targets.

- Time required to re-load the M203 and the M16A1.

- Time delay between the signal for FPF and the firing of the M16A1 FPF.

- Decision criteria for target selection with both the M203 and M16A1 when more than one target is available.

- Sensing error involved in determining if a target was hit by a M203 firing and a M16A1 firing.

SEQUENCE: COAX Machinegun (COAX SEQ)

- Number of spotting rounds required before Bushmaster is fired.

- Decision criteria for using the COAX as a spotter for the Bushmaster.

- Miss distance of a COAX burst against moving and stationary targets (not as a spotter).

- Sensing error involved in determining if a target was hit by a COAX burst.



SEQUENCE: Indirect Fire (IDF SEQ)

- Number of adjusting rounds required for a Platoon Leader to bring indirect fire on moving and stationary targets.

- Time delay between the initial fire request and the impact of the first round.

- Time delay between impact of the first round and impact of fire for effect.

- Decision criteria for target selection when more than one target is available for indirect fire.

All of the MOPs listed above are not entirely attributable to the Platoon Leader (or person calling in fire). However, the fact that parts of these MOPs involve the performance of the direct support field artillery Battery does not diminish their importance to the combat modeller.

SEQUENCE: Movement to Dismounted Alternate Fighting Position or Supplemental Fighting Position (MVMT TO DMTD AFP/SFP)

- Time required for a dismounted Squad to move to an AFP/SFP (moving together and separately).

- Range of enemy when move to AFP is initiated.

- Decision criteria for determining if a dismounted Squad moves together or separately to an AFP/SFP.

- Time of exposure of a dismounted Squad during a move to an AFP/SFP.

SEQUENCE: Movement to Mounted Alternate Fighting Position or Supplemental Fighting Position (MVMT TO MTD AFP/SFP)

- Time required for an Observer to mount an IFV from his observation point.





- Time required to move an IFV to and position it in an AFP/SFP.

- Range of enemy when move to a mounted AFP is initiated.

#### D. CONCLUSION

In their thesis [Ref. 6] Gerding and George proposed, among other recommendations, an Evaluator/Controller system which was primarily aimed at improving the effectiveness of ARTEP evaluations. However, they also realized an opportunity to gather data at little or no increase in required support resources. The measures of performance which such data should represent are those described in the preceding section. The purpose of this section is to examine the feasibility of gathering this data within the constraints of current and proposed evaluation procedures. For an indepth review of these procedures, the reader is referred to the aforementioned thesis and ARTEP 71-2 [Ref. 2].

Among the recommendations made by Gerding and George was a proposal that ARTEP evaluations be conducted in two phases; an on-line phase and an off-line phase. The off-line phase would consist of various evaluations of small unit elements down to crew level. These evaluations would involve the use of firing ranges, REALTRAIN, and other similar training aids and facilities. The on-line phase of the ARTEP evaluation, separated by three or four days from the off-line phase, would be composed of a scenario sequence which the evaluated unit would be required to accomplish. The off-line/on-line concept of ARTEP evaluation is very adaptable to data collection. As



Gerding and George point out, the off-line phase, by necessity, would have a large number of Evaluators/Controllers per evaluated unit. Considering this high density, it certainly seems reasonable to expect that the Evaluators/Controllers could gather data during the course of their small unit evaluations. In addition, virtually all of the evaluations that would occur in an off-line phase involve elements of Platoon size and smaller...precisely those levels at which much of the data representative of the recommended MOPs would have to be collected. As a result, the off-line phase of an ARTEP evaluation appears to present an excellent opportunity for gathering a considerable amount of data on the recommended MOPs (such as firing of weapons) with little, if any, increase in resource requirements or changes to evaluation procedures.

On the other hand, the scenario nature of the on-line phase of an ARTEP evaluation is such that extensive data collection may not be feasible, as it may unduly burden the Evaluators/Controllers and disrupt the flow of the tactical sequence. However, it may be possible for Evaluators/Controllers to collect data on some selected MOPs, such as those pertaining to Platoon or Squad movement between fighting positions, times required to dig positions, and other similar MOPs which should ideally be measured in the course of a tactical scenario. It should be emphasized that a minimum of data collection should be attempted during the on-line phase of the evaluation to prevent disruption of the scenario.

As for information concerning decision criteria, such data could be collected through several methods. A post-



evaluation questionnaire could be given to selected Platoon/Squad members immediately after the on-line phase while decisions which they made during the tactical exercise are still fresh in their minds. An alternative would be to administer questionnaires or interviews totally separate of any type of tactical evaluation.

There are two problems associated with collecting data from an ARTEP evaluation either as it is currently conducted or as envisioned by Gerding and George. First, some of the recommended MOPs would require instrumented firing ranges which are, in general, not readily available to most units in the Army. Such ranges exist but they are primarily used for experimentation and testing. Indeed, the recommended MOPs in this thesis may assist planners in determining range requirements for the Army's proposed National Training Center. Second, some of the recommended MOPs are derived from tactical operations not represented in the ARTEP 71-2. For example, there is no established evaluation which is conducive to collecting data representative of the MOP concerning a Platoon Leader's ability to call indirect fire. Thus, in some instances, it may be necessary to extend the tactical coverage of the current ARTEP.

SQT evaluations provide another opportunity for data collection. Some of the recommended MOPs concern the ability of a single soldier to perform a certain task (land navigate, emplace trip flares, emplace claymore mines, etc.) that involve no requirement for firing ranges or information



concerning decision criteria. Data representative of such MOPs could conceivably be collected during SQT evaluations without any change to current procedures. Indeed, some of this data is already collected but used only to support the go/no-go evaluation of the given task.

In general, the collection of data representative of the recommended MOPs seems compatible with current SQT and ARTEP evaluation procedures as suggested by Gerding and George. As mentioned, some changes to facilities and tasks to be evaluated would undoubtedly have to be made in order to collect some of the desired data. However, the Evaluator/Controller structure of SQTs and ARTEPs is such that data collection is possible, with little or no increase in required resources.

As stated previously, the purpose of this thesis was to identify certain MOPs and related data which could be collected during Army field training exercises, tests, and evaluations for use in combat and training analysis. Such MOPs for the Mechanized Infantry Platoon/Squad in the Active Defense have been identified and described through the use of the Flow Chart model presented in Chapter II and Appendix A. Based on a review of these selected MOPs, it was concluded that, with few exceptions, the necessary data to describe these MOPs could be collected in conjunction with existing ARTEP and SQT evaluation procedures.

However, this work constitutes only the first of several steps necessary to accomplish the ultimate objective of providing useful data for more effective decision making. What





ultimately is needed is a comprehensive data collection and maintenance plan, which should be the focus of continuing research in this area. Such research should be directed towards the following:

- The systematic identification of MOPs for other tactical ground and air operations of interest.

- The development of specific data collection plans for each of the MOPs identified.

- The establishment of a mechanism for insuring that data describing the selected MOPs are properly collected, maintained, and made available to appropriate agencies on request.



APPENDIX A: THE FLOW CHART MODEL

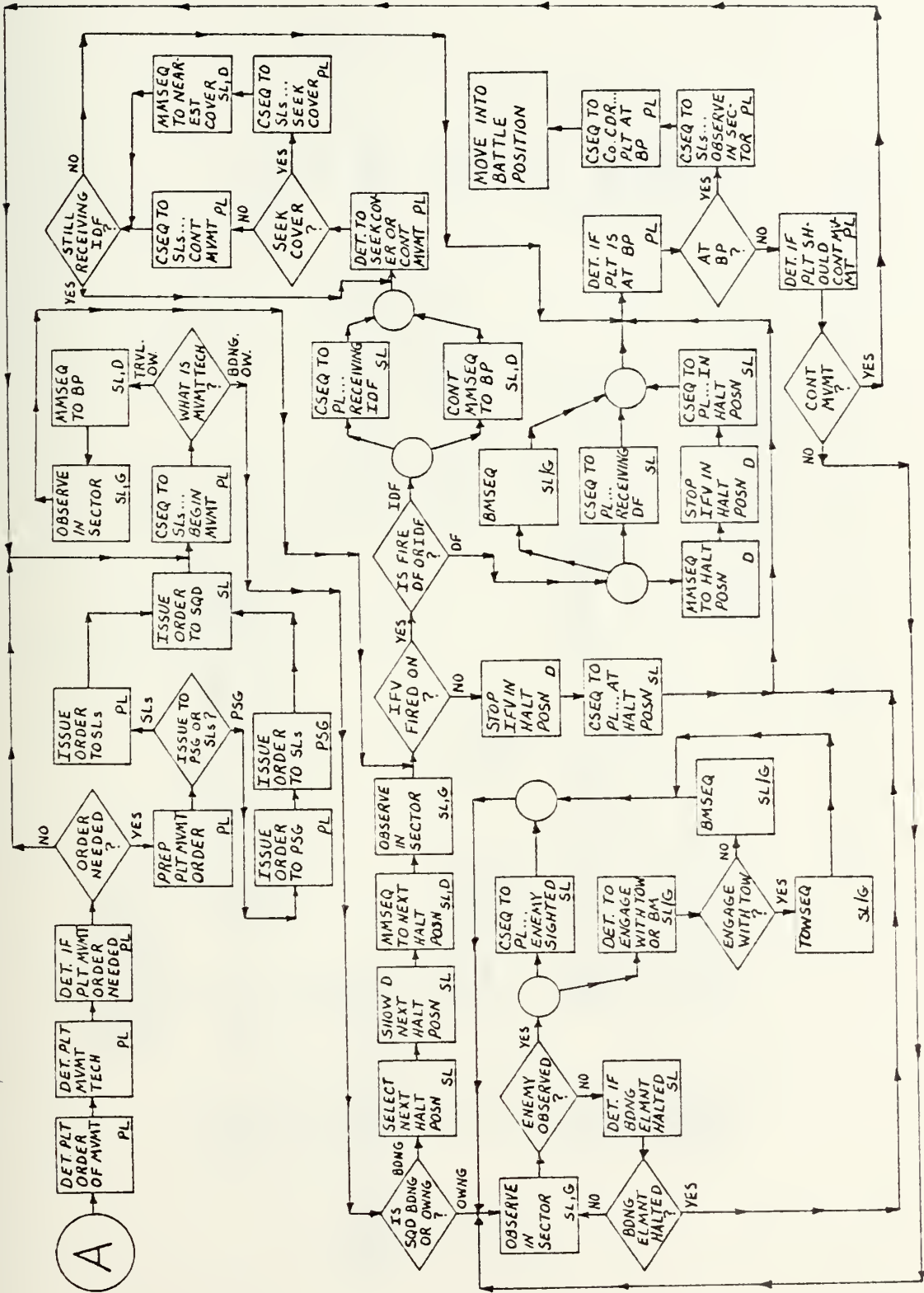

Figure A-1 (Move to Battle Position)













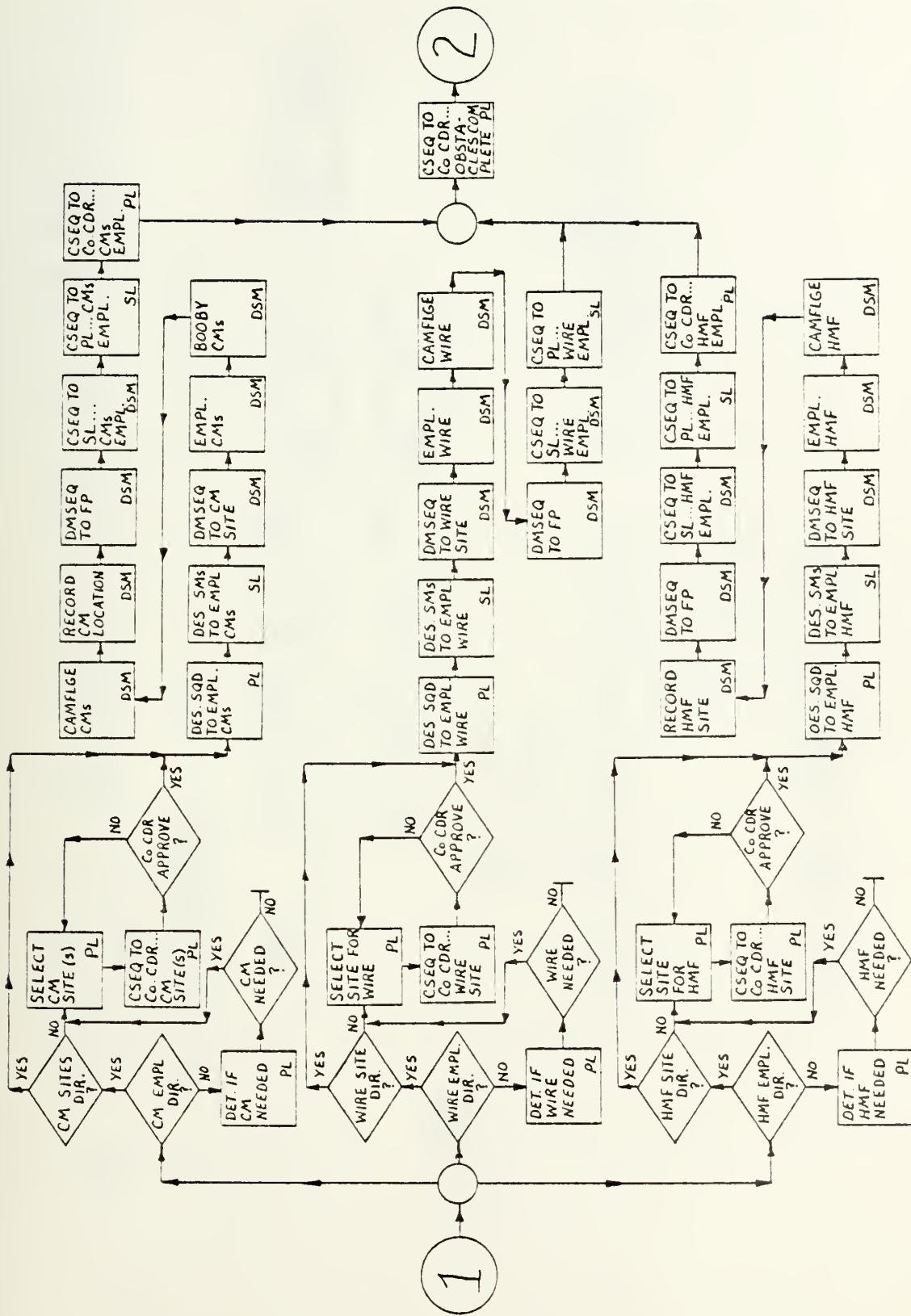

Figure A-4 (Create Obstacles)











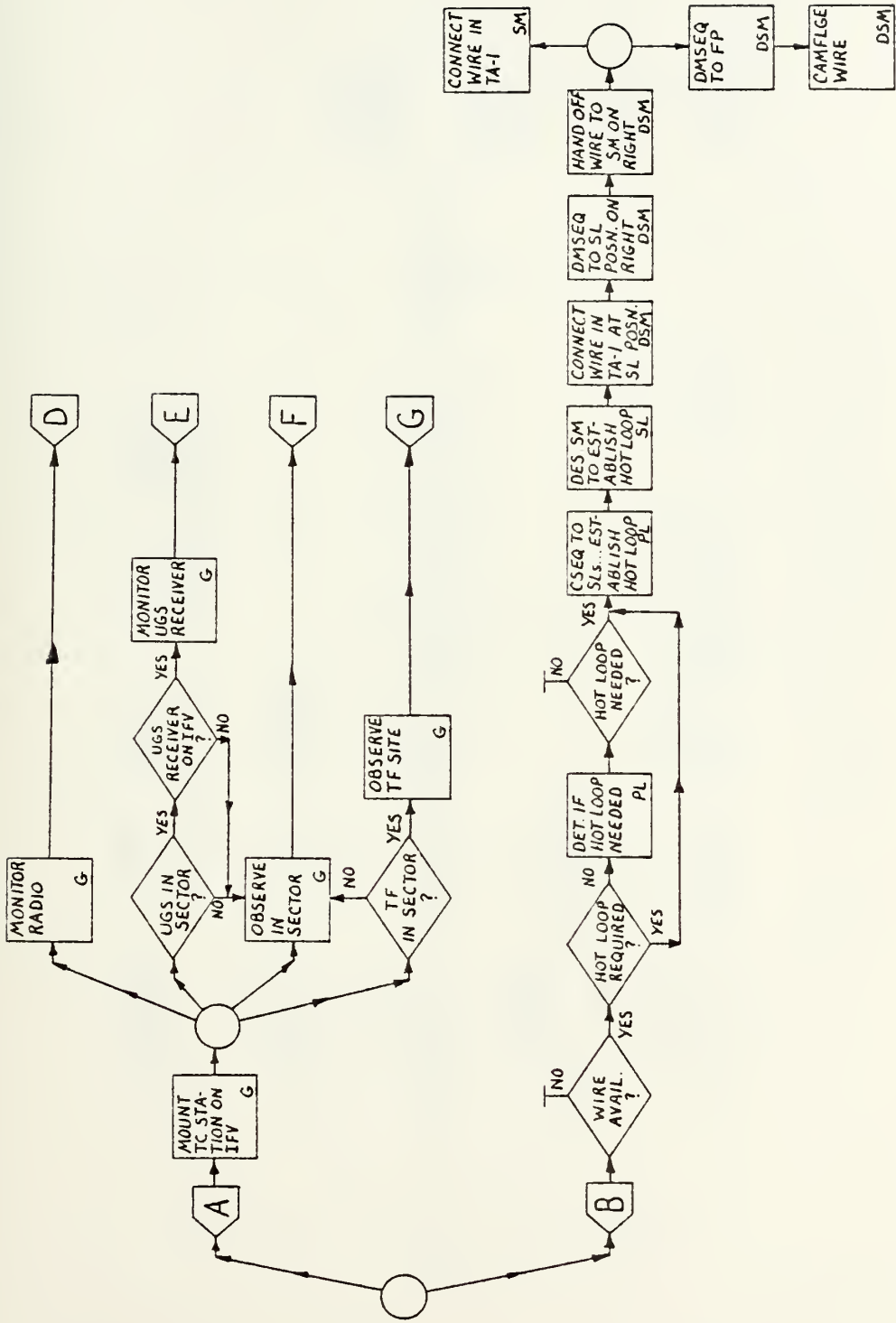

Figure A-6 ... Continued





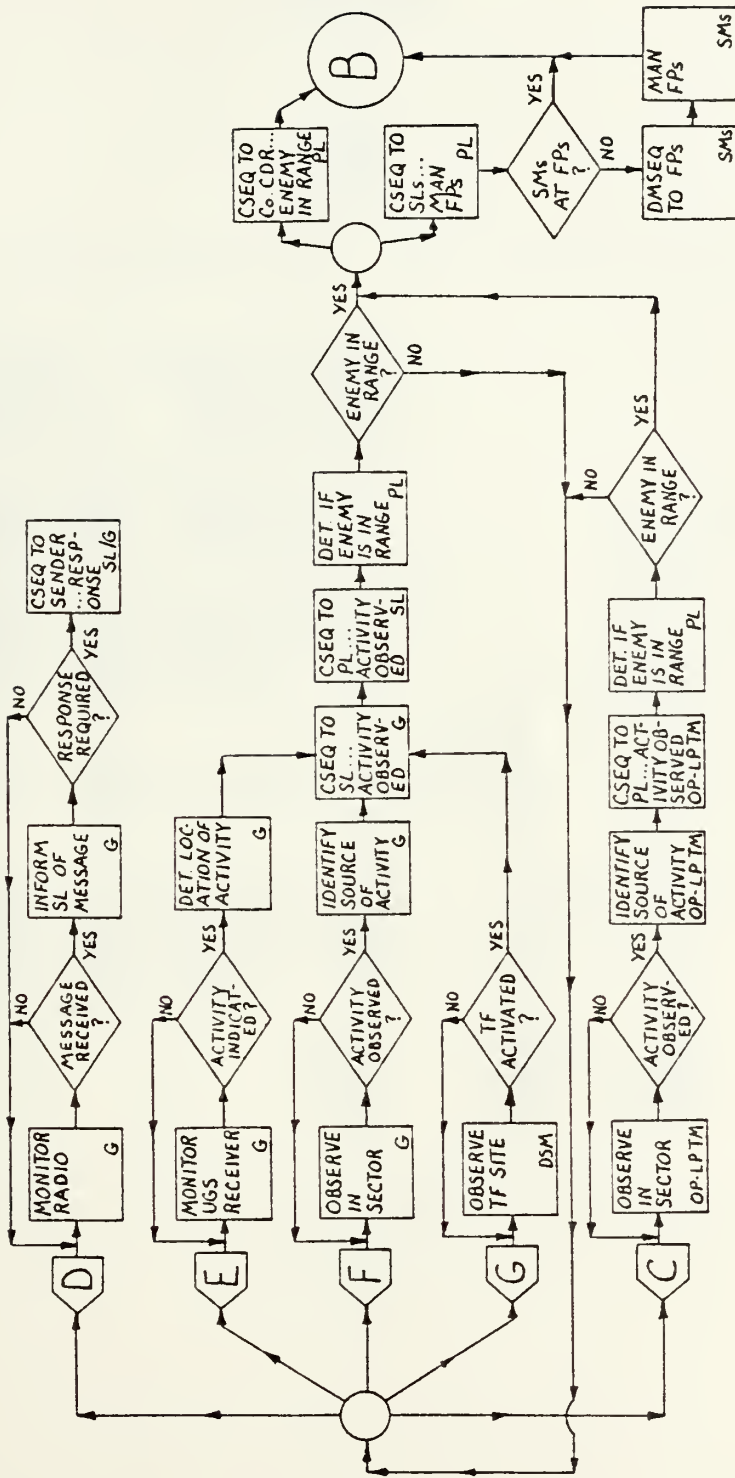

Figure A-7 (Maintain Security)



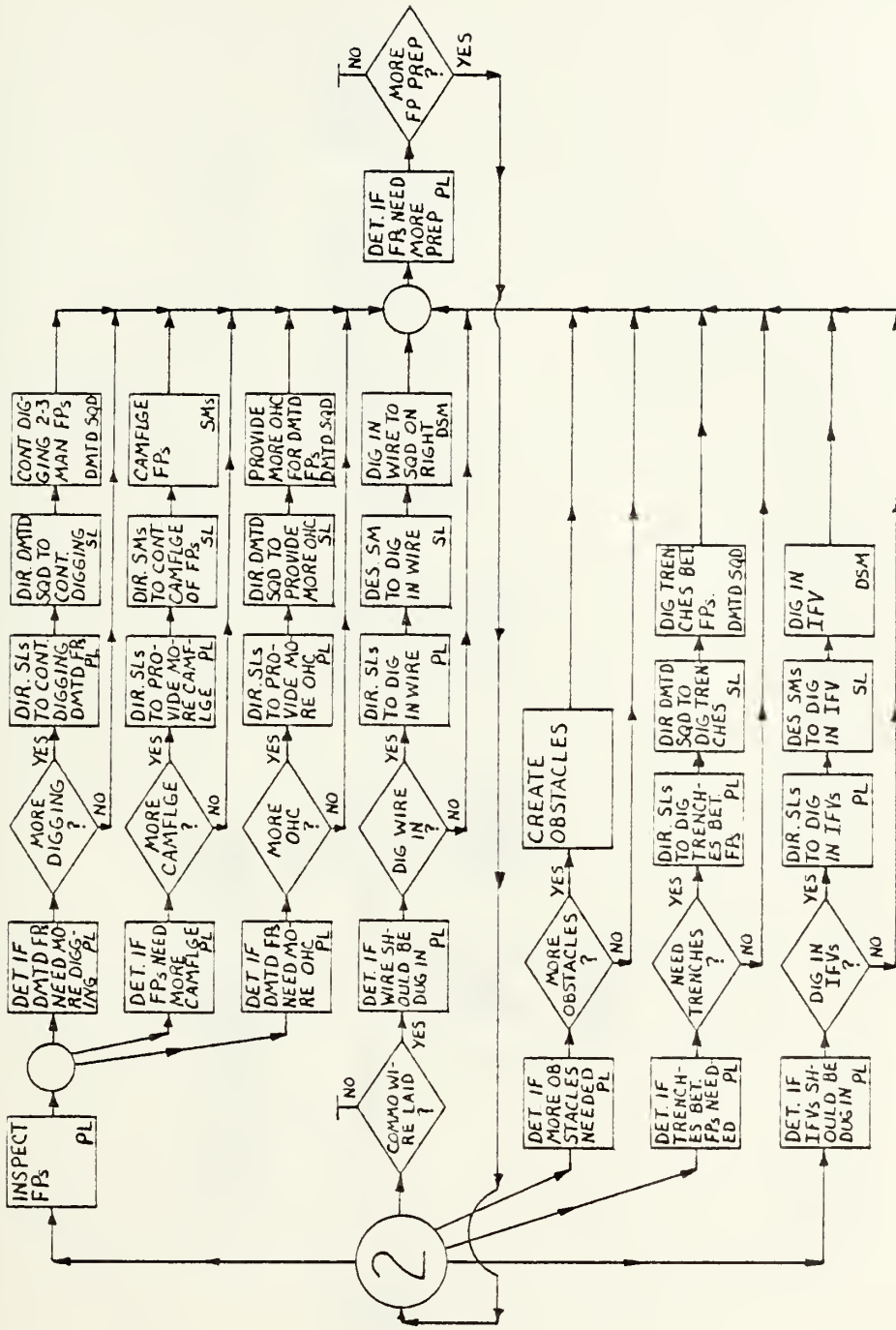

Figure A-8 (Continue to Prepare Fighting Positions)



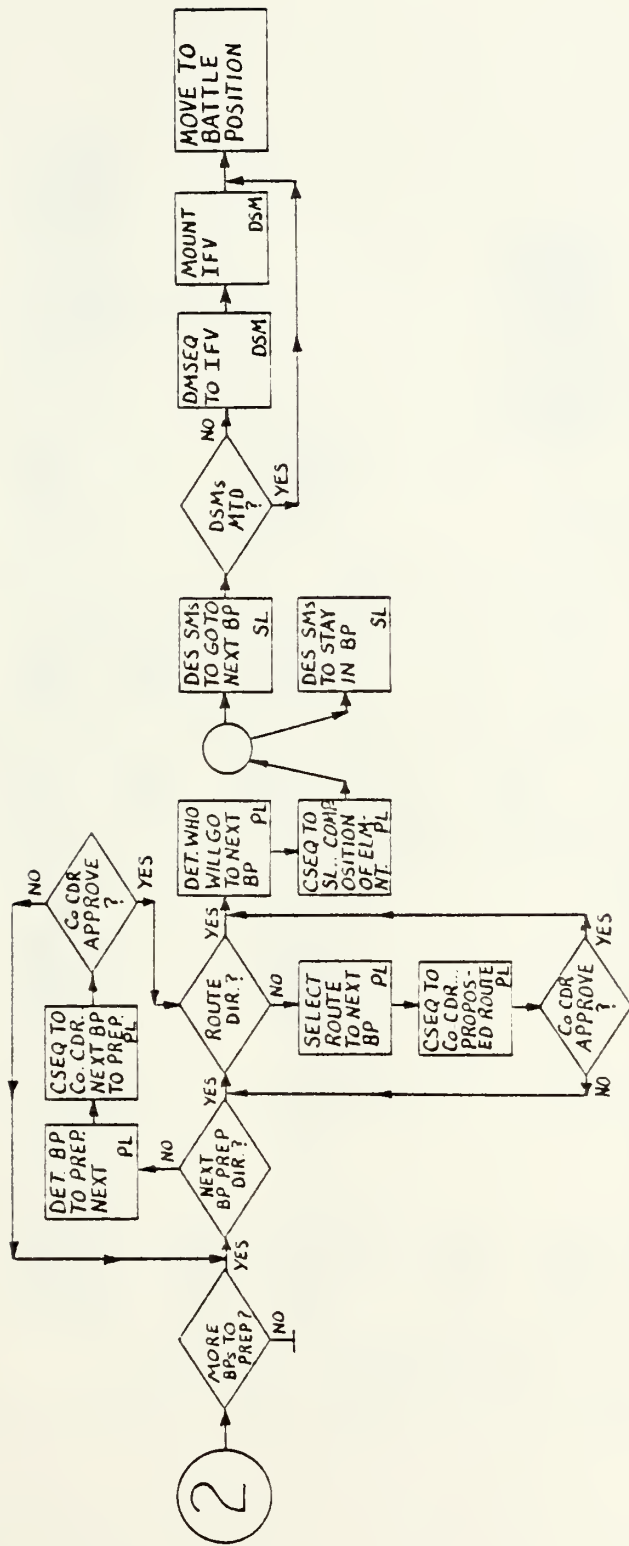

Figure A-9 (Prepare Future Battle Positions)









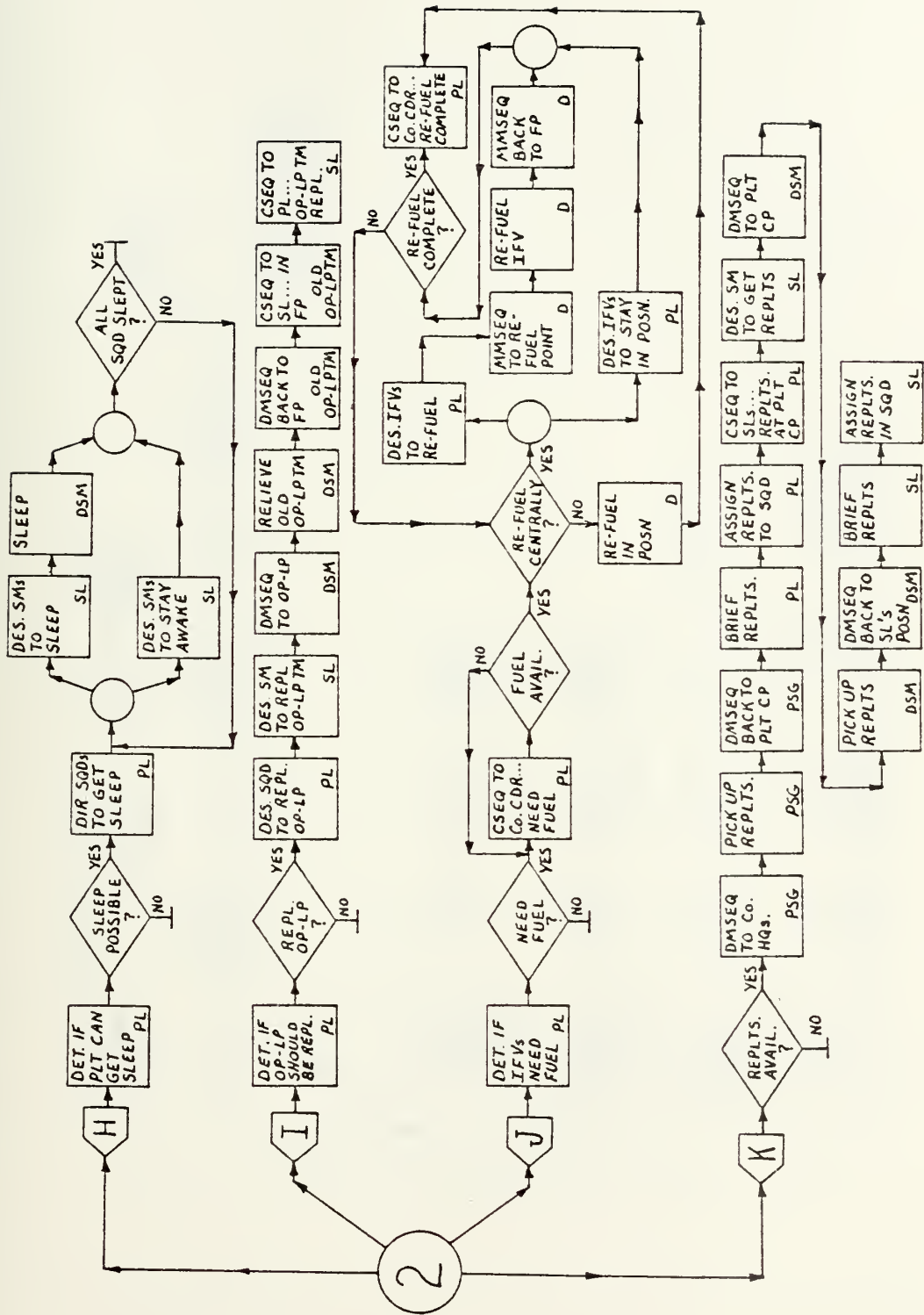

Figure A-10 ... Continued



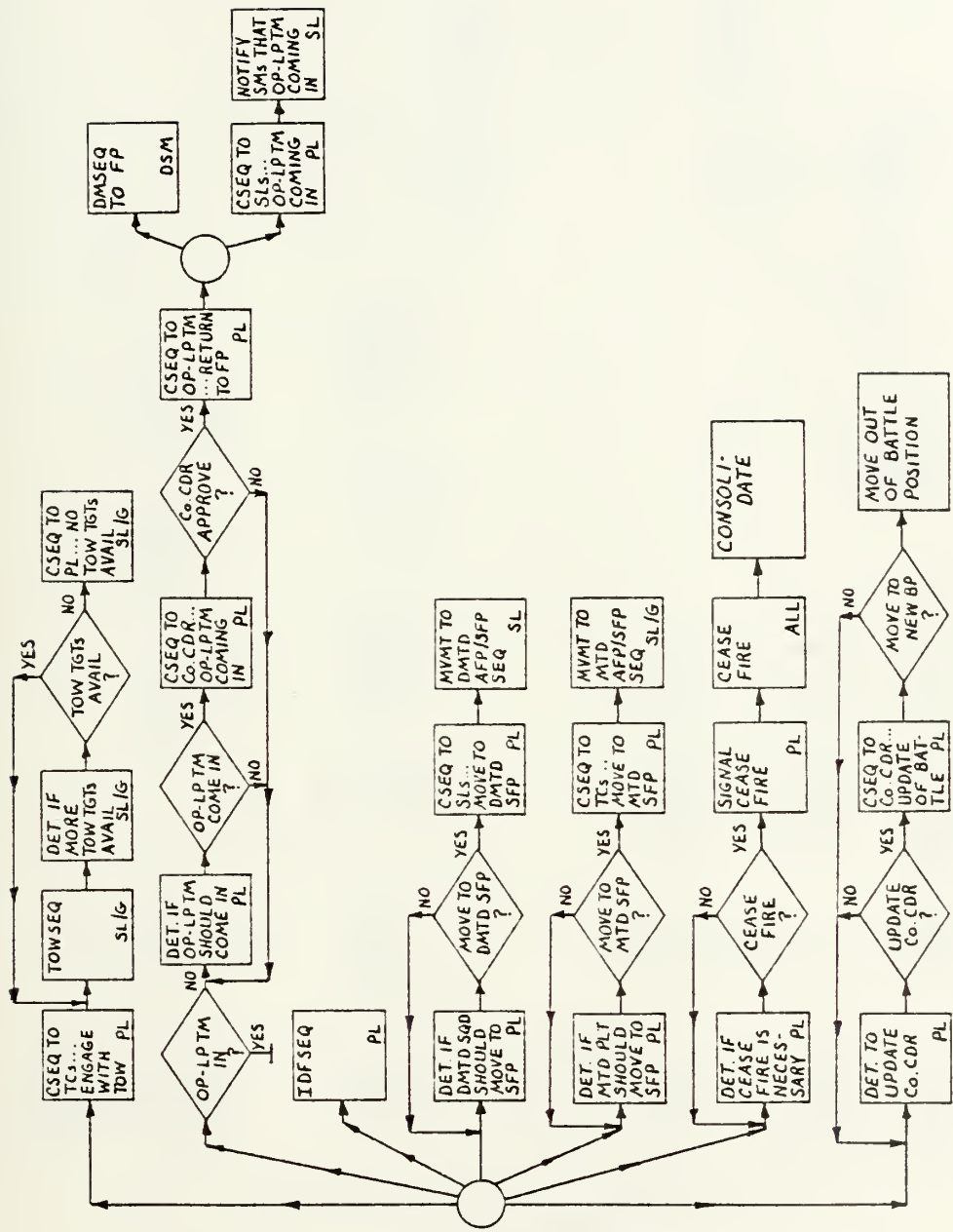

Figure A-11 (Engage Enemy Long Range)



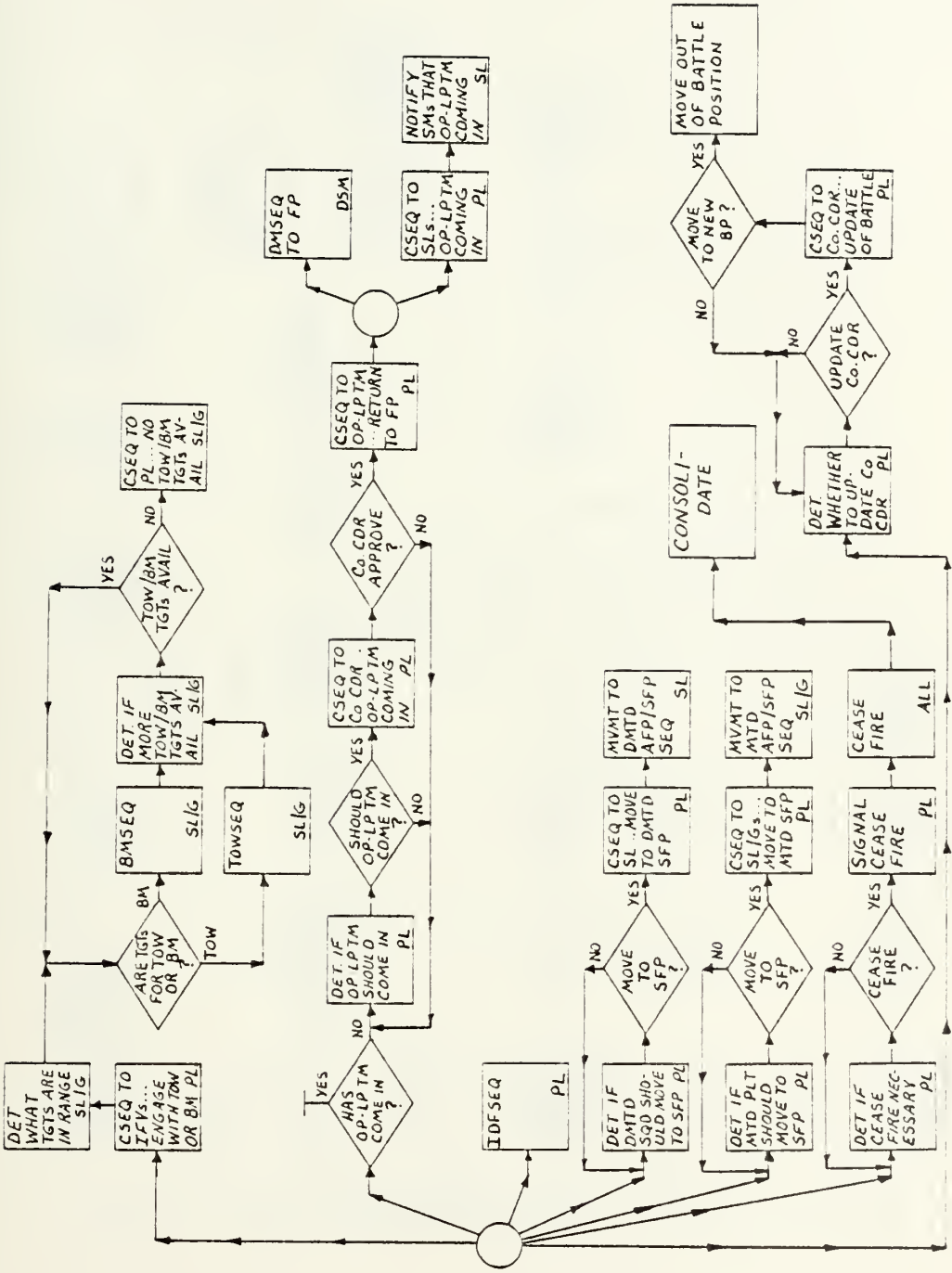

Figure A-12 (Engage Enemy Mid Range)









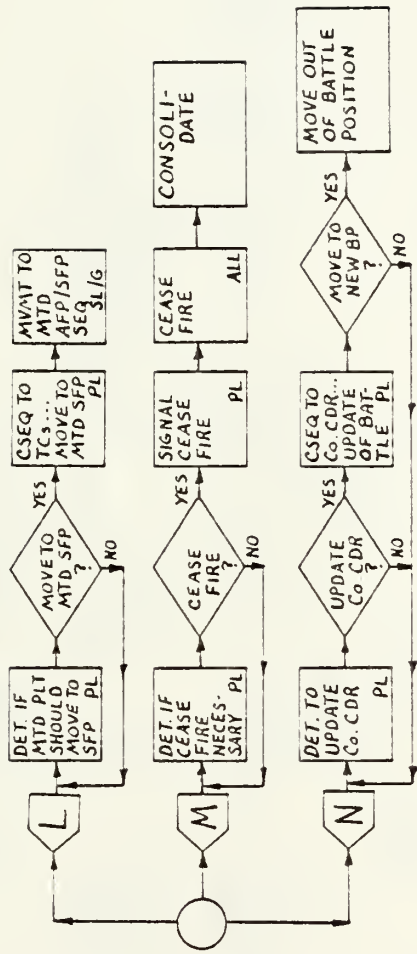

Figure A-13 ... Continued



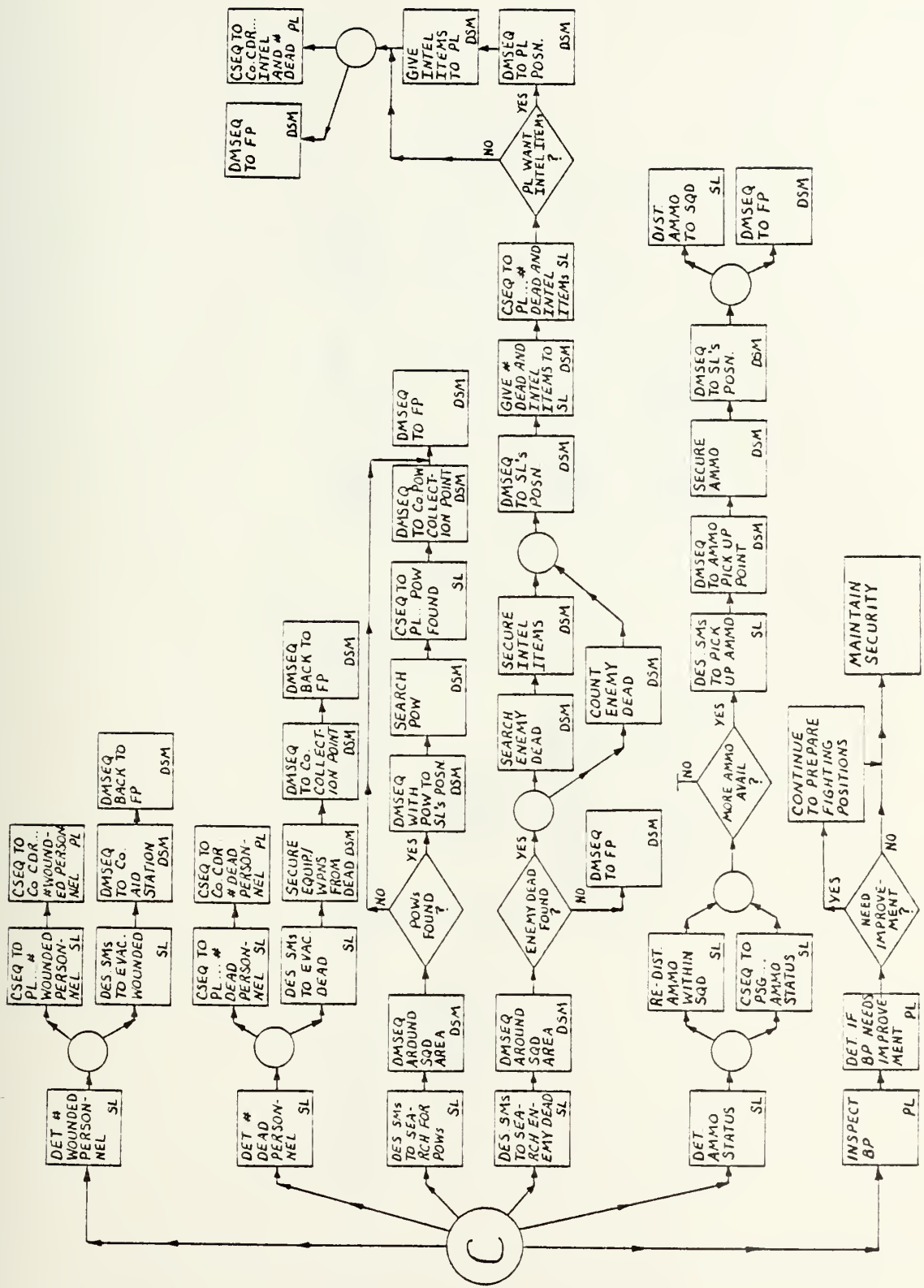

Figure A-14 (Consolidate)



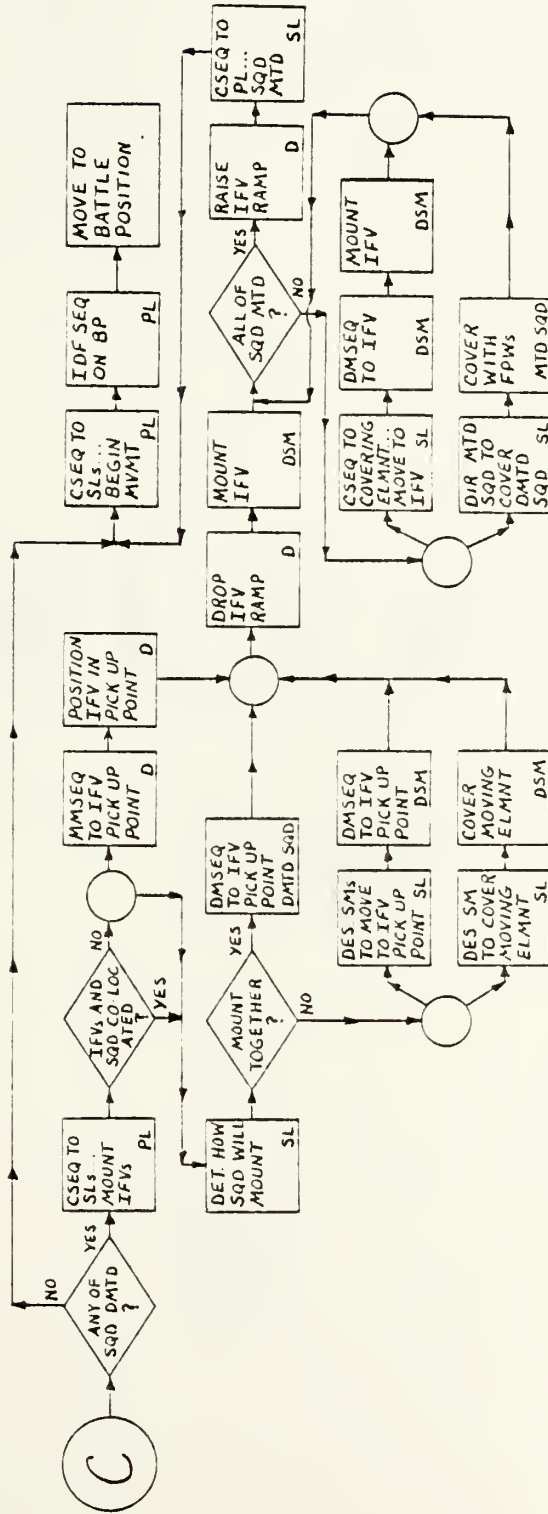

Figure A-15 (Move Out of Battle Position)



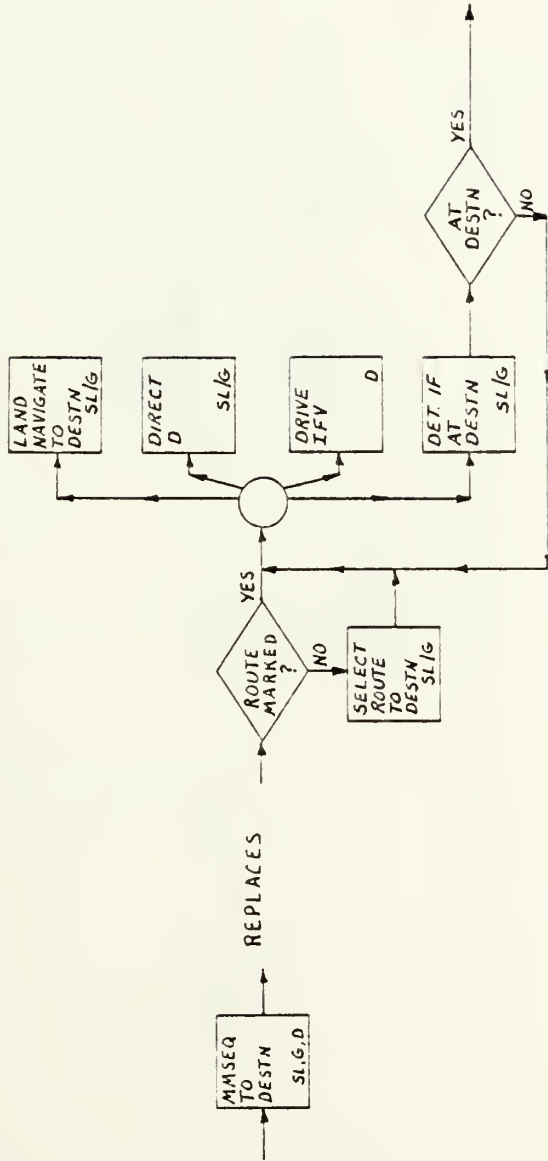

Figure A-16 (Mounted Movement Sequence)





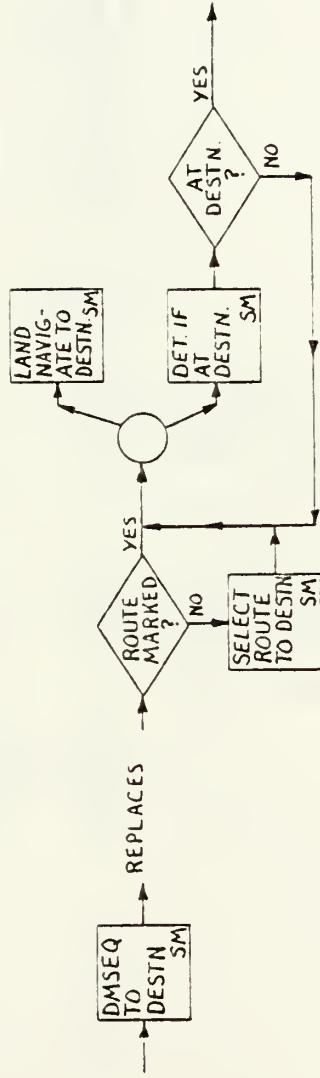

Figure A-17 (Dismounted Movement Sequence)



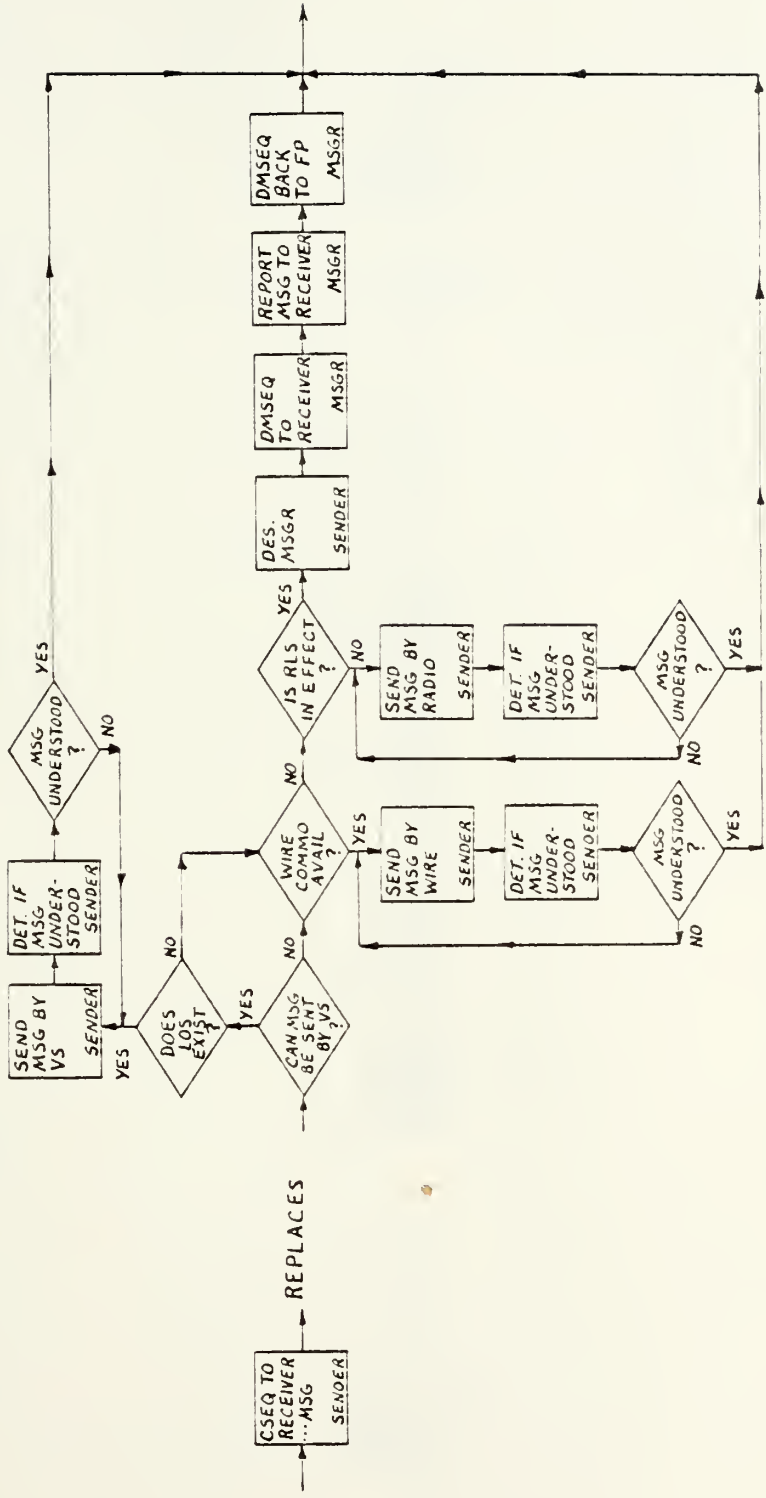

Figure A-18 (Communication Sequence)



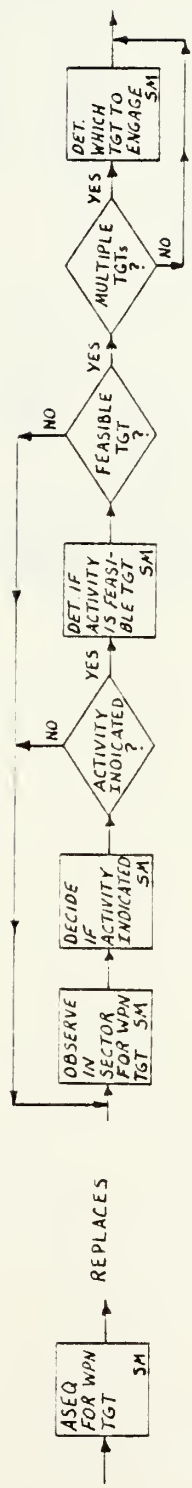

Figure A-19 (Acquisition Sequence)



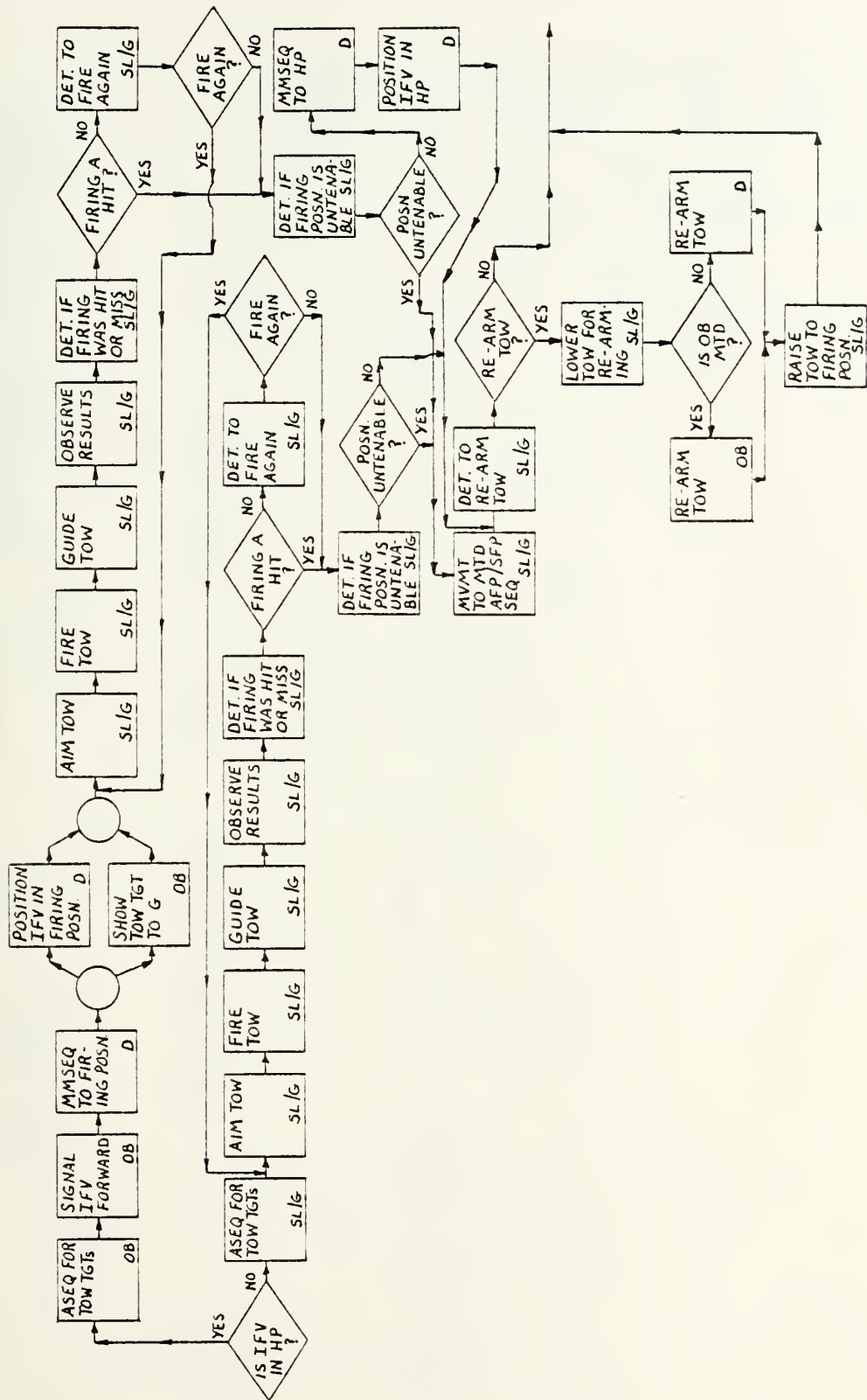

Figure A-20 (TOW Sequence)









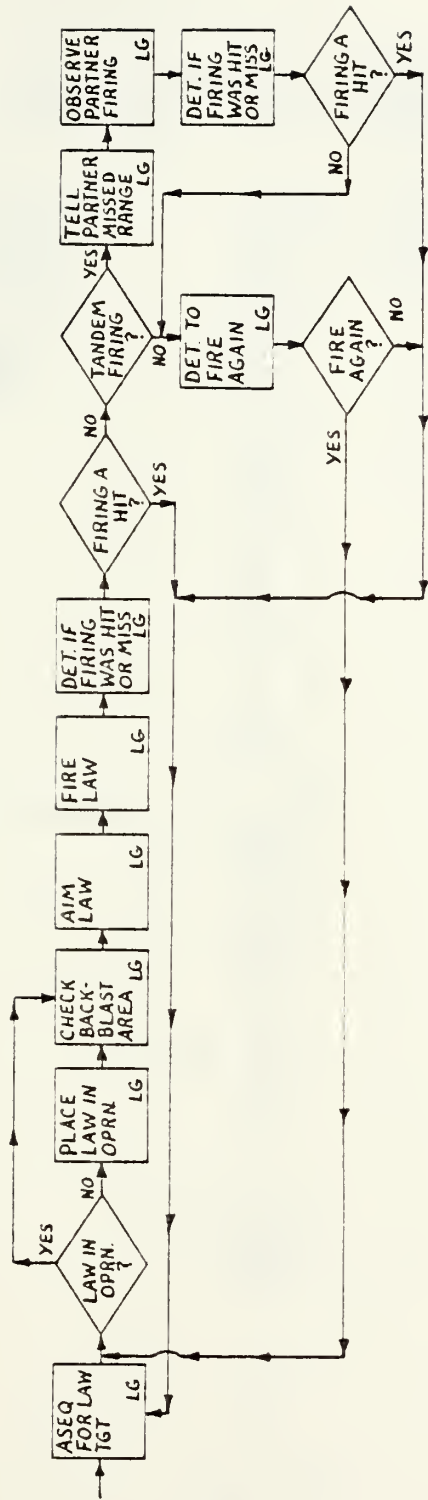

Figure A-22 (LAW Sequence)



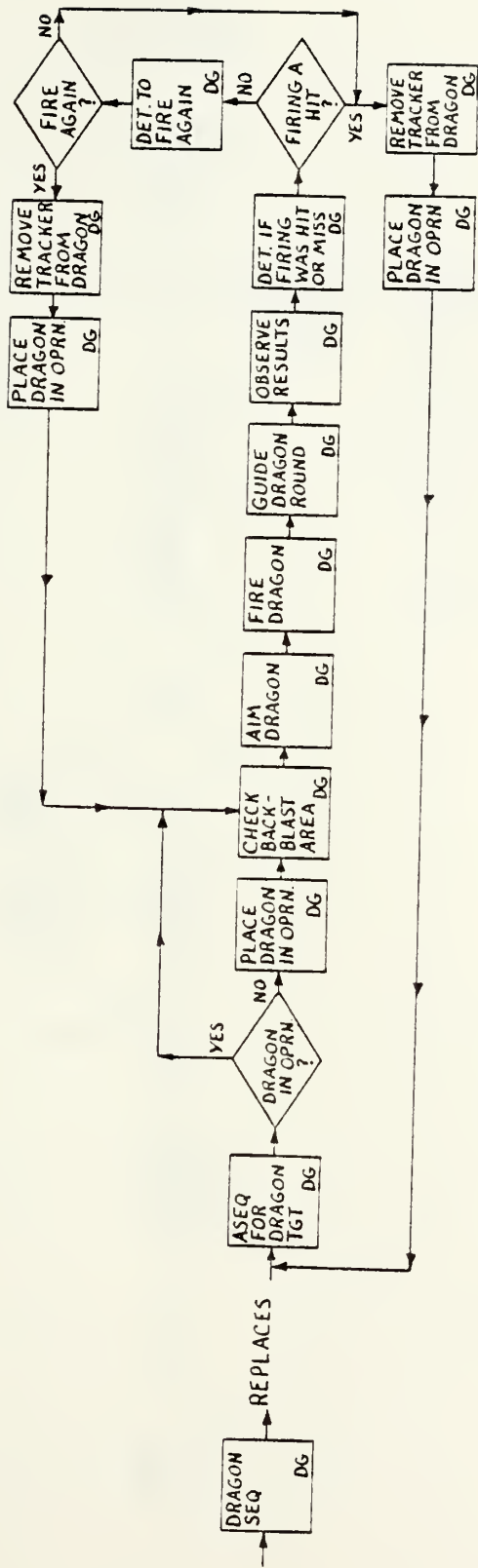

Figure A-23 (Dragon Sequence)



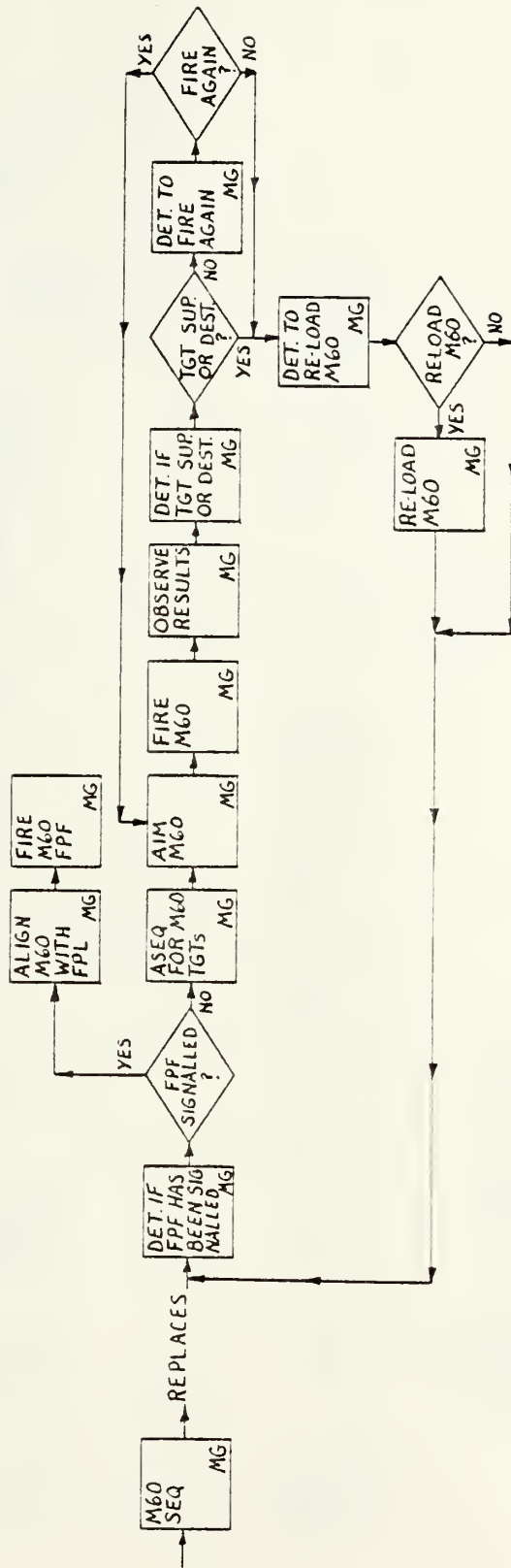

Figure A-24 (M60 Sequence)





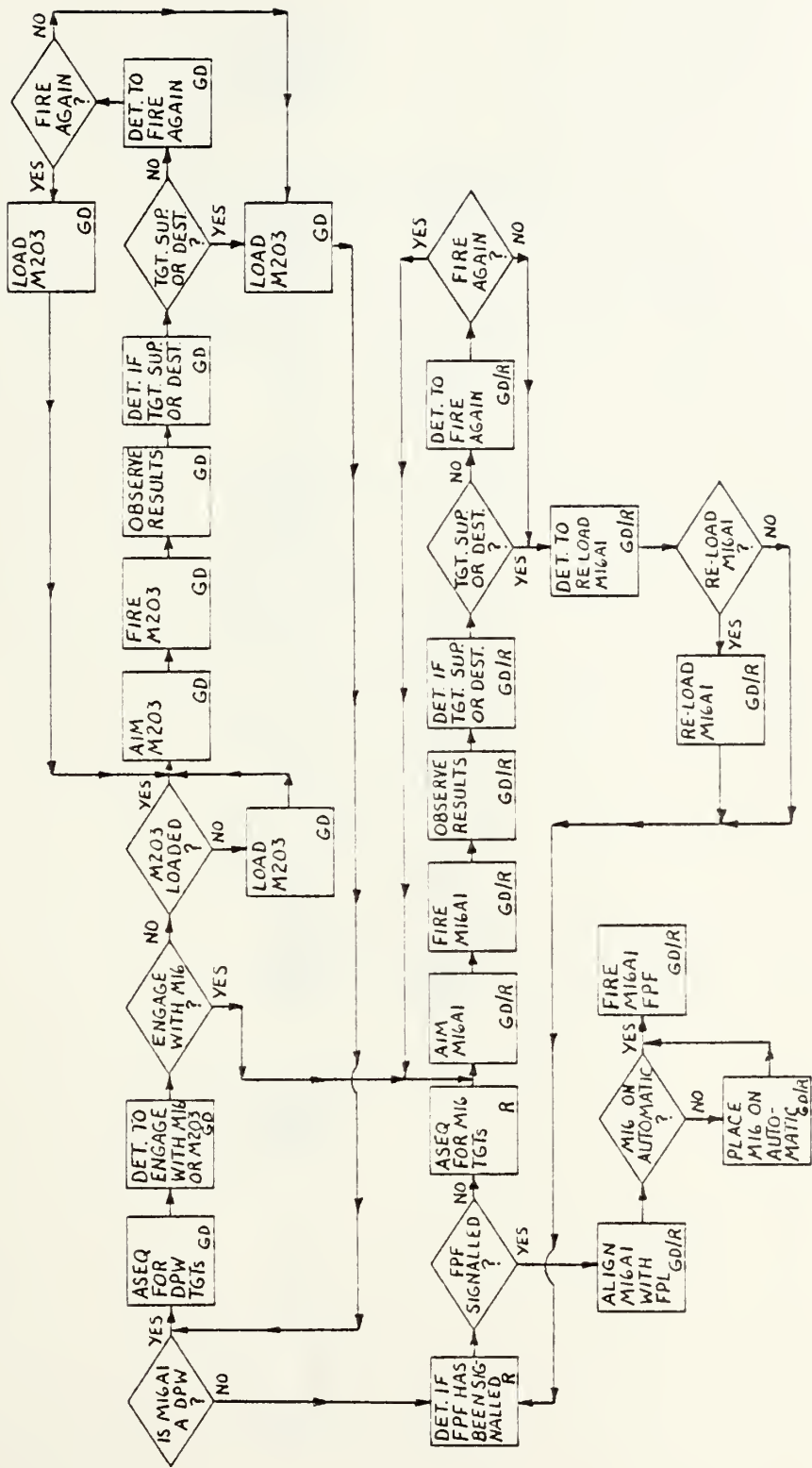

Figure A-25 (Dual Purpose Weapon Sequence)



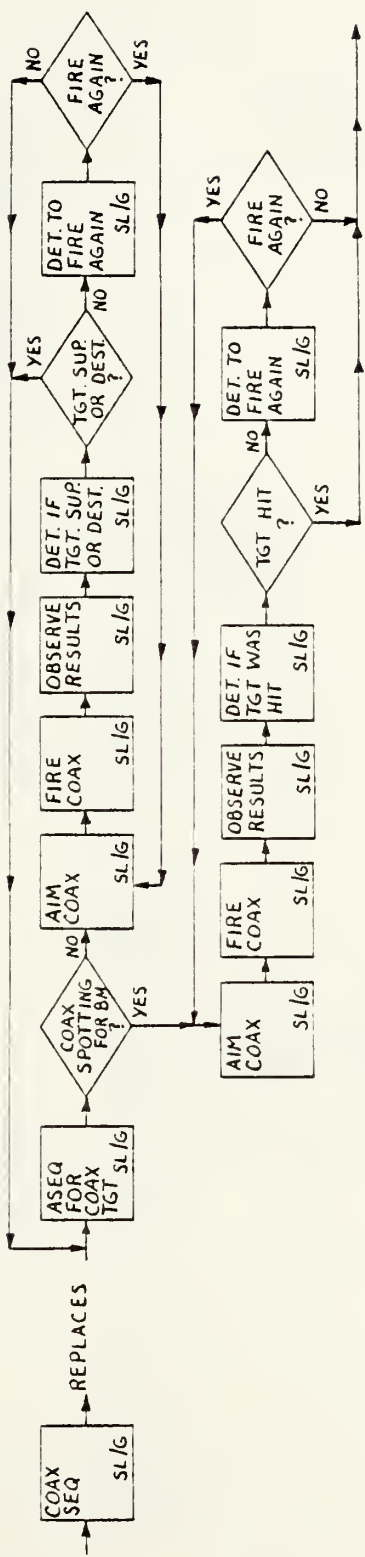

Figure A-26 (COAX Sequence)



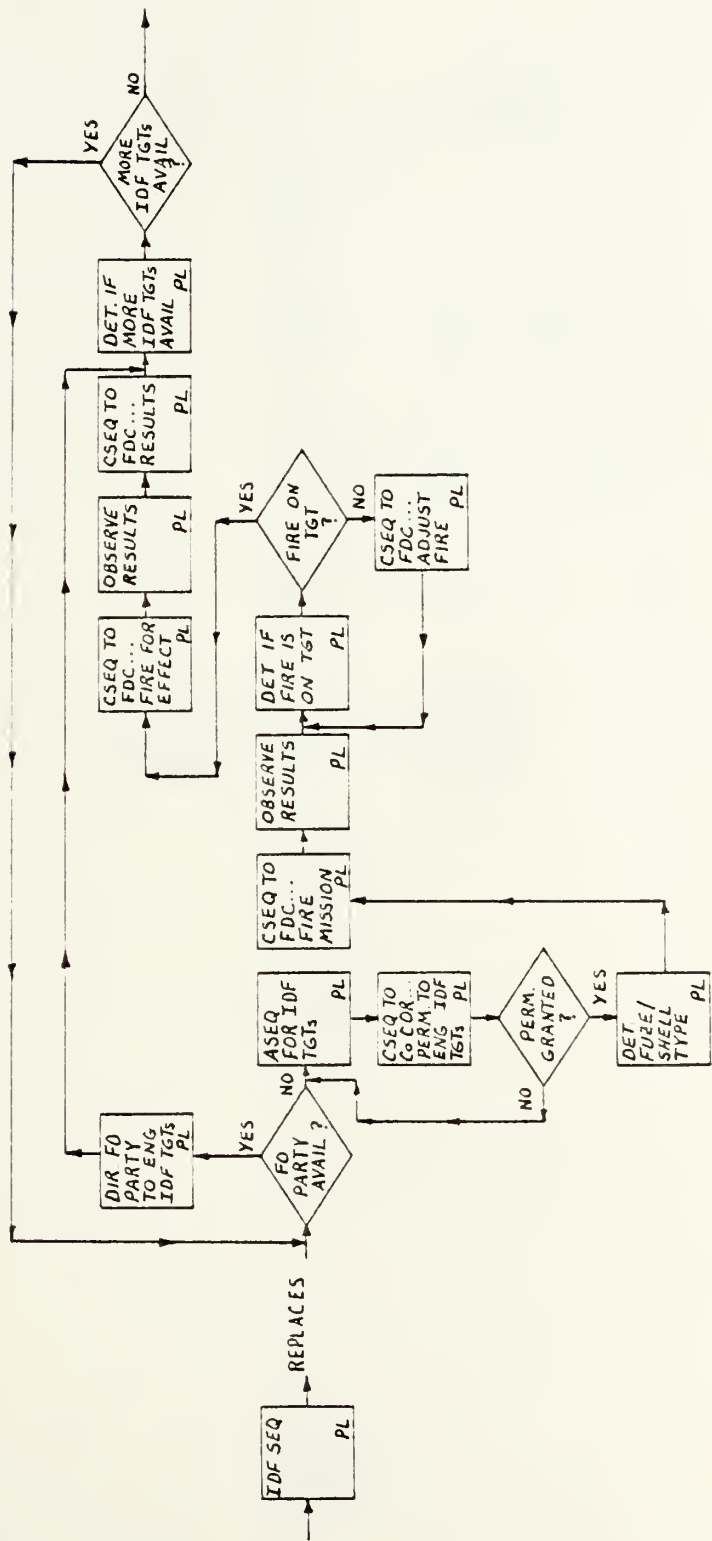

Figure A-27 (Indirect Fire Sequence)



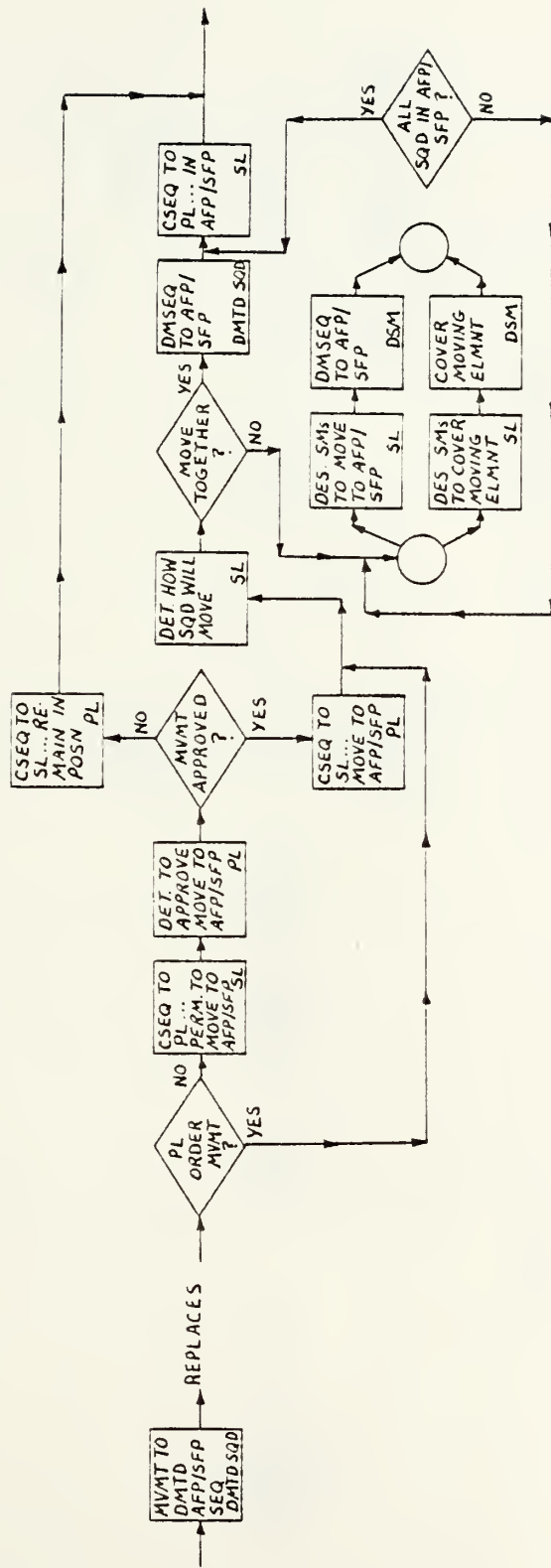

Figure A-28 (Movement to Dismounted AFP/SFP Sequence)





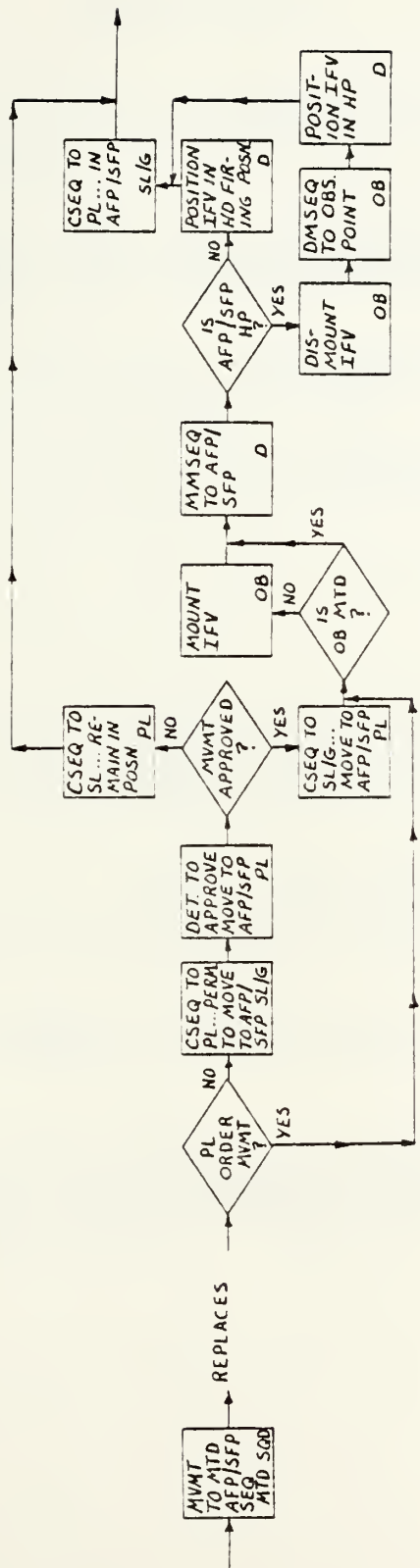

Figure A-29 (Movement to Mounted AFP/SFP Sequence)



## BIBLIOGRAPHY

1. Chaudrue, R. G. (LTC), "Requiem for the Infantry", Infantry Magazine, Vol. 68, Number 3, p. 28-31, May-June 1978.
2. Department of the Army, Army Training and Evaluation Program (ARTEP) 71-2, Mechanized Infantry/Tank Task Force, 17 June 1977.
3. Department of the Army, Field Manual (FM) 71-1, The Tank and Mechanized Infantry Team, 30 June 1977.
4. Department of the Army, Field Manual (FM) 71-2, The Tank and Mechanized Infantry Battalion Task Force, 30 June 1977.
5. Department of the Army, Field Manual (FM) 100-5, Operations, 1 July 1976.
6. Gerding, R. L. and George, D. P., An Application of Organizational and Managerial Principles as an Improvement to the Current Army Training and Evaluation Program for the Mechanized Infantry, M.S. Thesis, Naval Postgraduate School, Monterey, December 1978.
7. Stockfisch, J. A., Models, Data, and War: A Critique of the Study of Conventional Forces, prepared for the United States Air Force Project Rand, March 1975.
8. United States Army Infantry School, Directorate of Combat Developments, Contribution of Infantry to the Battlefield, July 1978.
9. United States Army Research Institute for the Behavioral and Social Sciences, Task Descriptions of Mounted Crew Operations for the MICV/TBAT II IFV, by H. P. Lenzycki, R. J. Eckenrode, and J. W. Hamilton, Vol. I, August 1978.



INITIAL DISTRIBUTION LIST

	No. Copies
1. Defense Documentation Center Cameron Station Alexandria, Virginia 22314	2
2. Library, Code 0142 Naval Postgraduate School Monterey, California 93940	2
3. Lieutenant Colonel Richard S. Miller Code 55Mu Department of Operations Research Naval Postgraduate School Monterey, California 93940	1
4. Professor Sam H. Parry, Code 55Py Department of Operations Research Naval Postgraduate School Monterey, California 93940	1
5. Captain Roland W. Carter 9213 Elizabeth Houston, Texas 77055	1
6. Headquarters U. S. Army Infantry School Directorate of Combat Developments ATTN: Major Graham Ft. Benning, Georgia 31905	1
7. Command and General Staff College ATTN: Education Advisor Room 123, Bell Hall Ft. Leavenworth, Kansas 66027	1
8. Headquarters U. S. Army Training and Doctrine Command Deputy Chief of Staff for Training ATTN: ATTNG-PA-NTC (Maj Fitzgerald) Ft. Monroe, Virginia 23651	3
9. Professor James K. Hartman, Code 55Hh Department of Operations Research Naval Postgraduate School Monterey, California 93940	1
10. Director Army Training Study Bldg. 734 Ft. Belvoir, Virginia 22060	1













15 OCT 79  
12 AUG 80  
20 NOV 81  
21 APR 82

26589  
S11499  
S11499  
26698

Thesis  
C27377  
c.1

Carter

Measures of  
performance for a  
mechanized infantry  
platoon and squad  
in the active  
defense.

180833

15 OCT 79  
12 AUG 80  
20 NOV 81  
21 APR 82

26589  
S11499  
S11499  
26698

The  
C27  
c.

DEC 2 '81

Thesis  
C27377  
c.1

Carter

Measures of  
performance of a  
mechanized infantry  
platoon and squad  
in the active  
defense.

180833

63027377  
Measures of performance for a mechanized

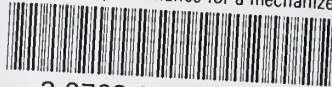

3 2768 001 02238 7

DUDLEY KNOX LIBRARY