

Historic, archived document

Do not assume content reflects current scientific knowledge, policies, or practices.

UNITED STATES DEPARTMENT OF AGRICULTURE



DEPARTMENT BULLETIN No. 1373



Washington, D. C.



Issued February, 1926
Revised March, 1928

DUST CONTROL IN GRAIN ELEVATORS

By

HYLTON R. BROWN and J. O. REED, Associate Engineers
Chemical and Technological Research
Bureau of Chemistry and Soils

CONTENTS

	Page
Introduction	1
Purpose of Investigation	2
Procedure	2
Methods of Dust Control	3
Dust-control Equipment	34
Conclusions	48

UNITED STATES
GOVERNMENT PRINTING OFFICE
WASHINGTON
1928



UNITED STATES DEPARTMENT OF AGRICULTURE



DEPARTMENT BULLETIN No. 1373



Washington, D. C.

Issued February, 1926
Revised March, 1928

DUST CONTROL IN GRAIN ELEVATORS

By HYLTON R. BROWN and J. O. REED, *Associate Engineers,*
Chemical and Technological Research, Bureau of Chemistry and Soils

CONTENTS

	Page		Page
Introduction.....	1	Dust-control equipment.....	34
Purpose of investigation.....	2	Fans.....	34
Procedure.....	2	Piping system.....	34
Methods of dust control.....	3	Dust collectors.....	35
Dust collection.....	4	Grain traps.....	35
Dust removal.....	22	Suction regulators.....	36
Natural ventilation.....	31	Effect on grain weights.....	46
Mechanical ventilation.....	33	Conclusions.....	48

INTRODUCTION

From 1919 to 1925 dust explosions in the United States in plants handling grain and grain products caused the loss of 133 lives, injury to 130 employees, and property damage amounting to more than \$12,000,000. As more than one-fourth of the loss in life and more than one-half of the property damage occurred in grain elevators, special attention has been directed to the elimination of the dust-explosion hazard in the grain elevating industry.

The requirements for a dust explosion are (1) dust in suspension in air in a certain proportion, and (2) some means of igniting this dust and air mixture.¹ Such explosions, then, may be prevented by using equipment which will eliminate all sources of ignition around the plant, or by controlling the dust and air mixture so that no explosive dust clouds can be formed. For some time attention was directed to the elimination of open flames around plants where it was possible for the explosion hazard to exist. When it was found that electric sparks, blown fuses, broken electric lamps, hot bearings, friction fires, metallic sparks, static electricity, and fires caused by spontaneous combustion could ignite the dust, however, attention was turned to the development of equipment for controlling the dust.

More efficient work can be done in a clean, orderly, and well-run plant than in one where dust clouds are permitted to form. Furthermore, dusty atmospheres may affect the health of the workmen. Aside from reducing the dust-explosion hazard, then, the installation of dust-collecting equipment improves the health and efficiency of the workmen.

¹ D. J. Price and H. H. Brown, "Dust Explosions," published by National Fire Protection Association, Boston, Mass., 1922.

ACKNOWLEDGMENT.—All drawings were made by Robert M. Baker.

PURPOSE OF INVESTIGATION

The Bureau of Chemistry learned that many of the dust-collecting systems installed in grain elevators throughout the country could not be used or were dismantled because of the objection of the officials having jurisdiction over the weighing of the grain. The weighing departments stated that grain weights are greatly affected by the action of suction used in the collection of the dust. Reports of tests conducted by a number of elevator operators, however, indicated that the weight of the dust removed is almost negligible. Some men experienced in handling grain have stated that less dust is removed by suction than is lost in handling grain by means of poor machinery, with no dust-collecting equipment.

Confronted with these conflicting statements, the Bureau of Chemistry made a preliminary study of the effect of dust collection on the weight of grain. The results showed that much depended upon the design and installation of the dust-collecting equipment. In many cases the equipment seemed to have been installed with no knowledge of the fundamentals of good design. In some cases the claims of weighing departments that grain had been drawn out by improper application of suction to remove the dust at certain points between the car which was being unloaded and the scales, were probably correct. No information concerning a generally accepted method of applying suction or the proper equipment to use could be obtained. Every elevator seemed to have its own system of dust control and no standards existed. None of the systems were so installed as to permit inspection, nor were they so designed that it would be impossible to lift grain by increasing the speed of the fan, with a corresponding increase of suction.

The results of these preliminary investigations showed the necessity for a detailed study of the problems of controlling the dust conditions in grain elevators.

PROCEDURE

Office studies, field investigations, and laboratory experiments have been conducted.

Office studies.—The reports and recommendations of various regulatory bodies concerning the maintenance of grain weights between the different terminal markets were compiled. Engineering data on fans, air-velocity measurement, ventilation, and grain-elevator equipment were obtained. Patents on dust-collecting equipment and technical articles recommending various dust-control appliances were examined.

Field work.—A survey was made of the dust-control equipment in a number of representative terminal elevators along the Great Lakes, the Atlantic coast, and the Gulf coast, including plants having the greatest variation in type of building and dust-collecting and removal equipment and in grain-handling methods. As a rule, the most modern and largest elevators at each point were visited. A few of the older elevators, where dust-collecting systems had been recently installed according to ideas based on practical experience of the operating officials, were also visited.

The layout of the dust-collecting system was carefully studied in each plant. All the points where suction was applied, floor sweeps installed, or natural ventilation provided were carefully noted. The dust conditions at various points in the grain-handling system were noted, and the causes for those conditions were determined as nearly as possible. A drawing of the dust-collecting systems and detail drawings of all dust-control applications were made. The efficiency of the dust-control equipment and the effect of suction at various points were observed. Other data to assist in determining the proper methods of controlling dust at various points were obtained.

At all suction hoods observations were made to determine whether the air velocity was great enough to lift and carry grain while collecting dust. When a hood apparently was not functioning satisfactorily notation was made of its construction and installation, its distance from the fan, and the number of elbows and suction connections attached to the main duct and branch through which the suction was provided. Tests were made to determine the air velocity at the point of application of suction by means of an anemometer inserted beneath the hood.

Pitot tubes were employed, according to the methods commonly used, for testing the performance of the fans of the dust-collecting system. The fan speed was recorded by a speed counter.

The apparatus developed in the dust-explosion prevention laboratory of the Bureau of Chemistry to determine the quantity of dust present in the air ² was used to determine the density of dust clouds at various points.

In all these surveys an effort was made to improve the equipment found. A public-service patent was granted to the Department of Agriculture for an improved design for a piece of equipment to replace one which was unsatisfactory. Many of the recommendations submitted to the officials of the elevators visited have been adopted.

Laboratory work.—The air velocity which will collect the dust but will not lift the grain was determined in the laboratory. Hoods providing a permanent and assured control of the air velocity at the point of application of suction and an efficient grain trap were designed and tested. All equipment recommended in this bulletin has been tested, so far as possible in the laboratory, under conditions similar to those existing in grain elevators.

METHODS OF DUST CONTROL

The dust conditions in a grain elevator are effectively controlled only when (1) dust clouds are eliminated at their point of origin by the application of suction, (2) dust accumulations are promptly removed from the building, either by a vacuum cleaning system or by a floor-sweep system, and (3) the elevator and equipment are well ventilated.

In this bulletin the mechanical methods of controlling dust conditions have been divided into dust collection and dust removal. Dust collection deals with the methods of removing dust clouds at their source by means of induced air currents, supplied through specially designed hoods connected to a fan system. Dust removal

² L. J. Trostel and H. W. Frevert, "Collection and Examination of Explosive Dusts in Air," published in *Industrial and Engineering Chemistry* (1923), vol. 15, no. 3, p. 232.

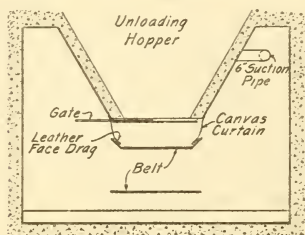
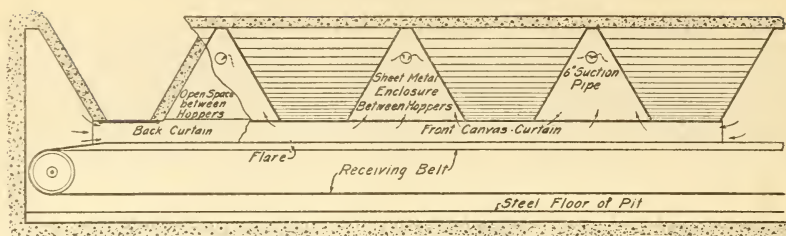

SECTION OF UNLOADING PIT

FIG. 1.—Application of suction system to unloading pits

deals with the methods of removing static dust, that is, dust which has settled and accumulated on the floors, walls, equipment, etc. Ventilation has been divided into natural ventilation and mechanical ventilation.

DUST COLLECTION

Dust clouds rise at all points in the grain-handling system where grain is thrown, agitated, or brought in contact with air currents. If no provisions are made for collecting these dust clouds, dust deposits are formed on the floors and equipment. The proper use of dust-collecting devices and equipment at dust-producing points, therefore, not only eliminates the floating dust but also prevents the formation of dust deposits. As the removal of dust deposits requires labor, the advantage of using well-designed dust-collecting equipment, which automatically removes the dust cloud at its inception, is apparent.

Dust is collected by means of suction produced by a fan. Hoods or suction connections are placed over all the points where dust clouds are created. All these hoods are served by a piping system leading to the eye of a fan, preferably outside the elevator, which exhausts into a cyclone dust collector on the roof of a dust house, 75 to 200 feet from the elevator. In many cases a grain catcher is placed directly ahead of the fan to separate the good grain from the dust.

AT RECEIVING PITS

The dustiest points in an elevator are usually about the discharges of the receiving or unloading pits. As a rule the discharges of these pits are under the track shed, in small inaccessible tunnels, through which the receiving belts run to the workhouse. In many cases no natural ventilation exists, nor can it be provided in this areaway, making dust-collecting equipment necessary to remove the dust which escapes from the grain as it flows out of the pits upon the belts.

The suction system shown in Figure 1 was applied to the receiving belts at the unloading pits in one of the elevators visited. The space between the hoppers is inclosed, and a 6-inch suction connection is made near the apex of each triangular inclosure or near the point where the hoppers join. On each side of the belt, a canvas curtain, which drags on the inside of the upturned trough part of the belt, completely incloses the space above the receiving belts for the entire length of the hoppers. The dust-laden air, which rises from the belt when grain is being discharged from one of the hoppers, is thus confined and exhausted through the three 6-inch suction pipe connections. This application has been very effective in controlling the dust clouds at the receiving pits. As no induced air currents come in contact with the moving grain, only the dust clouds which rise from loading grain on a belt being finally drawn from the inclosure, this installation has had no effect on the grain weights.

An installation (fig. 2) similar to that shown in Figure 1, but much simpler to install, can be adapted to a receiving-pit hopper of almost any type. A canvas curtain hangs down by the sides of the hoppers and drags on the inside of the receiving belt. The open spaces between the hoppers not covered by the belt are inclosed by either sheet metal or canvas, so that all the dust rising from the grain flowing on the belt is confined in the space between the belt and the hoppers. As a stream of air several inches deep follows a loaded conveyor belt at an average velocity of approximately one-fourth the belt speed, the space between the curtains is left open at the end where the belt first runs under the hoppers, making it possible for the air to flow in the direction of the belt and toward the other end of the inclosure. At the other end, however, the space between the curtains is inclosed by sheet metal and a curtain which drags on the grain. A rectangular suction hood of the proportions of the hood shown in Figure 32 is placed over the end curtain about 18 inches above the belt. Suction is supplied through a 7-inch pipe from the main duct of the dust-collecting fan system.

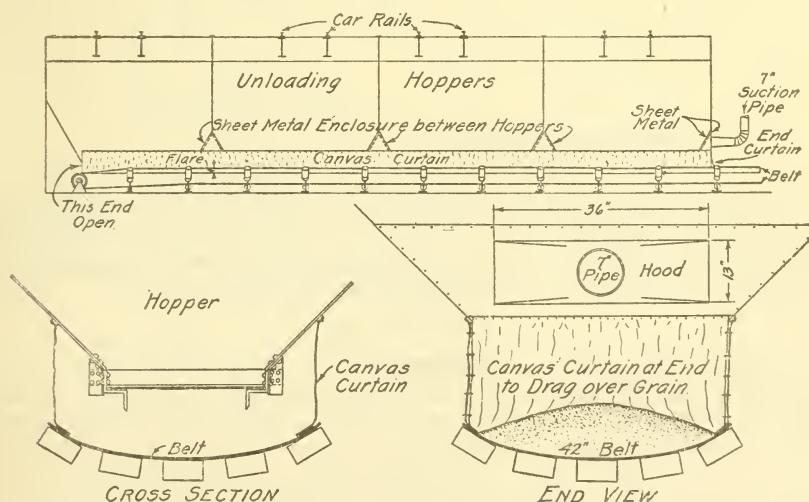

FIG. 2.—Proposed suction system for receiving pits

The hood is designed to exhaust from the inclosure only the dust-laden air, which is brought to it by the belt. It is not meant to induce a flow of air over the grain, so that particles of chaff, etc., may be picked up and interfere with the grain weights. A velocity-control valve and an inspection trap (fig. 29) can be used with this hood if desired.

The main objection to these installations is that the curtain hampers inspection of the gates beneath the hoppers, although many of the receiving pits in elevators are so inaccessible that inspection of the gates is difficult under any circumstances. An interlocking device, such as is used in railroad switch controls, on the receiving pit gates should overcome any objection to the use of the curtain inclosures. One elevator has used the system successfully for several years.

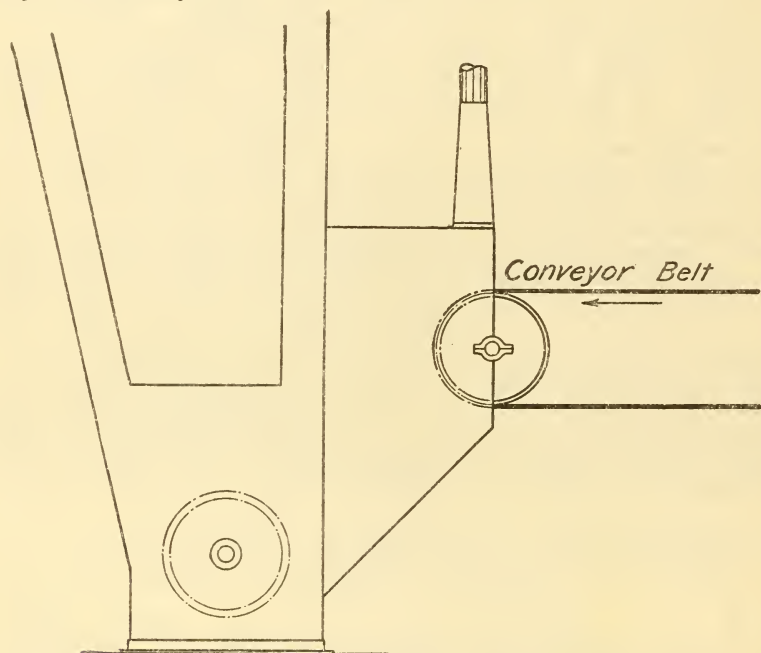

FIG. 3.—Application of suction to elevator boot by vertical hood

As the receiving pits are usually below the level of the basement floor, sweep hoods should be placed in the tunnels or areaways in which the belt runs. The conveying belt should be far enough from the floor to permit easy cleaning beneath the belt.

AT ELEVATOR BOOTS

Feeding grain into an elevator boot, by either a belt or a spout, produces heavy dust clouds. As a large volume of air in the elevator buckets is being displaced by grain there is within the boot a surplus of air, which in coming in contact with the disturbed grain becomes heavily laden with dust. As a result, dust clouds issuing from the elevator boot fill the basement, which is the most difficult floor in an elevator to ventilate and keep clean. The control of this dust

condition about the boot therefore depends upon the removal of the surplus air in the boot, by means of an air suction connection from a fan system or a vent to the outside of the building. It is necessary only to exhaust the air from the boot as fast as it accumulates. No excessive velocities are required to draw out the dust.

It has been found difficult to apply suction to elevator boots in such a manner as to remove all suspicion that the installation may be able to lift grain, chaff, and other light material, thus interfering with the grain weights. In practically every dust-collecting installation at elevator boots, it is necessary to use a hood so designed that the air enters the hood, preferably in the form of a curtain, and is not of sufficient velocity to lift dust particles from the grain stream. The United States Department of Agriculture hood (p. 37) was designed to meet all the requirements for such an installation.

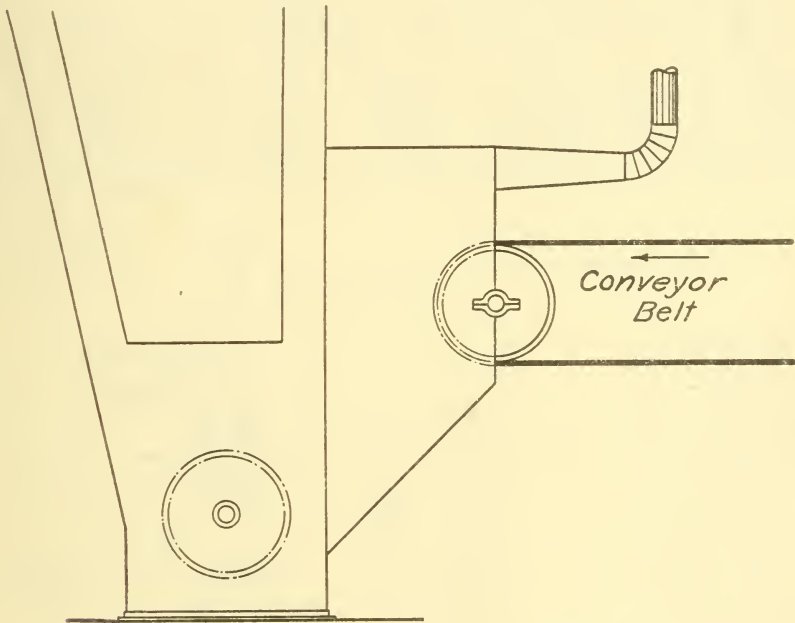

FIG. 4.—Application of suction to elevator boot by horizontal hood

Even a properly designed hood may prove unsatisfactory unless it is at a point where grain cannot be thrown into the hood opening and where there is no possibility that a "choke-up" may back up grain into the hood and give the suction an opportunity to draw out grain. When the suction connection can be made at some distance from the grain, it is sometimes possible, although not advisable, to use a direct pipe connection. When suction is applied to the boots, into which receiving belts discharge grain from cars, it is well to place a trap in the suction line to prove that the installation does not interfere in obtaining the correct grain weight. A velocity control valve (fig. 29), used in conjunction with the trap, makes it possible to regulate the air velocity in the branch line.

Many methods of applying suction to elevator boots are in use. The suction connection may be made on the front leg, on the back

leg, on the side of the boot, on the top of the boot, or on the spout feeding the leg. Not all of these methods, however, are satisfactory.

When a belt discharges directly into a boot, the common practice is to place a dust-collecting hood in a vertical position at the boot opening (fig. 3). In some cases the hood is placed in a horizontal position (fig. 4). Both of these installations have advantages and disadvantages. For equally effective results the vertical hood must be larger and handle more air than the horizontal hood. The horizontal hood, however, is more likely to draw in grain that is thrown into the mouth of the hood. In some cases an elbow at the opening of the vertical hood (fig. 5) gives the good points of both hoods. A vertical hood, having the proportions of the United States Department of Agriculture hood, with the elbow having a radius one and one-half times the width of the hood, is satisfactory.

In the case of a spout feeding into the boot it is sometimes possible to place the hood above the point where the spout enters the boot. If the grain is far enough from the induced air currents, it may be possible to make a direct connection at this point (fig. 6). The application of suction to the front leg or the back leg or on the side of the boot is not satisfactory. When connections are made in the front and back leg, the dust conditions in the boot are not very well controlled. The installation of hoods in the front leg and the side of

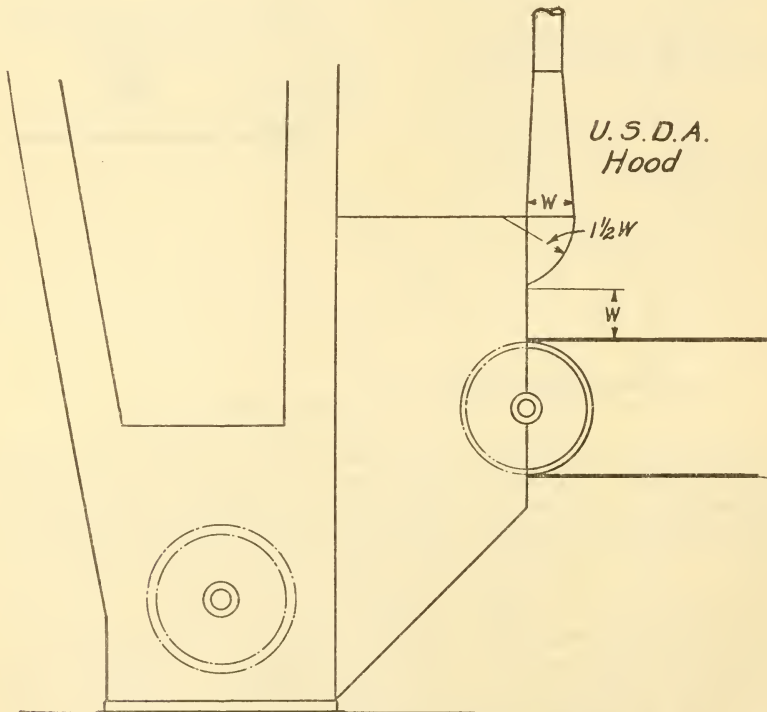

FIG. 5.—Hood equipped with elbow intake for elevator boot

the boot gives too great a chance for the removal by suction of the grain and heavy dust particles. The most satisfactory point is at the boot opening or on the top of the boot.

A satisfactory method of caring for dust within a boot is to place a hood between the legs (fig. 7). This installation removes the air re-

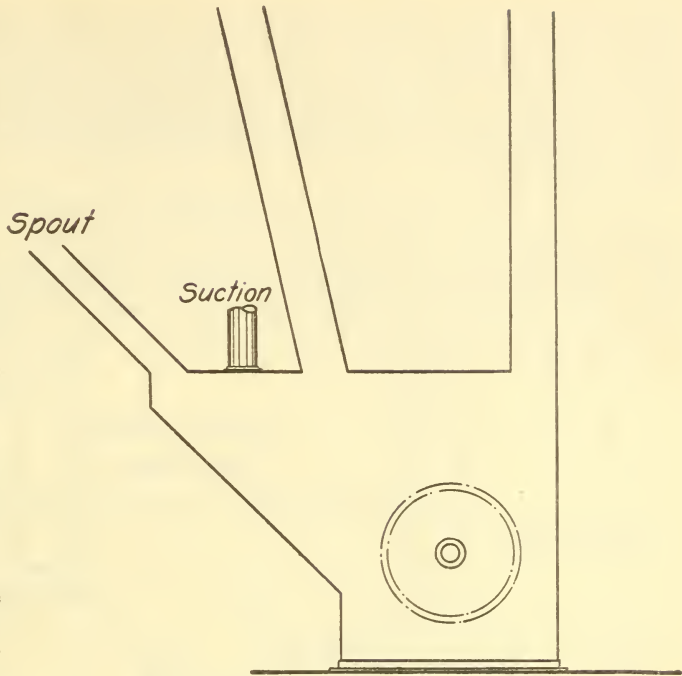

Fig. 6.—Direct suction connection to elevator boot

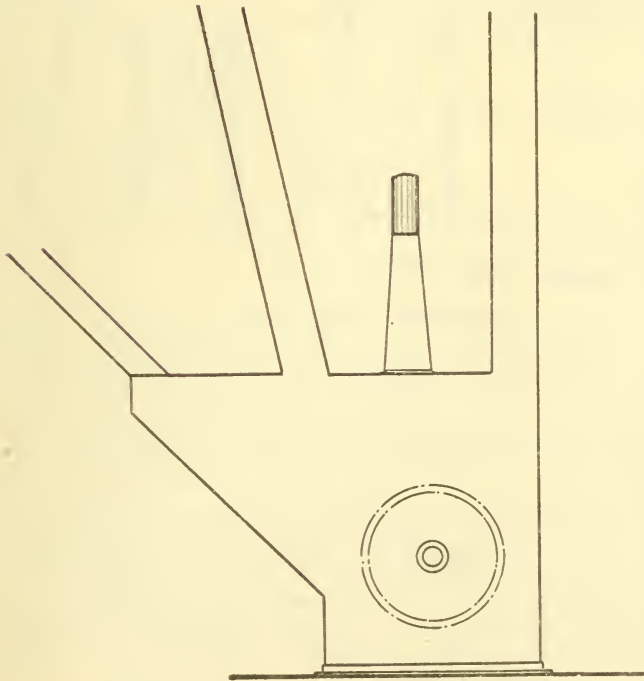

Fig. 7.—Application of suction between legs of elevator

S3278°—28—2

placed by the grain, especially when the grain is being fed into the back leg or side of the boot. For spouting connections to boots, this system is satisfactory. At this point grain can not be lifted, even when there is a choke-up in the boot.

Feeding a boot through a floor grating, by either a tripper or an open spout, presents a difficult problem in controlling the dust cloud

from the boot pit. Hoods connected to large suction pipes have not proved entirely satisfactory. In most cases a fixed hood can not be used. A hood similar to a window awning is sometimes attached to the elevator leg. To be effective, these awning hoods must be close to the grating and attached to a large suction pipe. If properly designed, there seems to be no reason why they can not control the dust at this point.

One elevator has successfully used a hood over the grating to combat the dust conditions at that point. This hood is placed over a section of the grating, and canvas or other heavy cloth is used to cover the rest. This provides a suction on the grain entering the boot pit at any point through the grating, from either spouts or tripper (fig. 8).

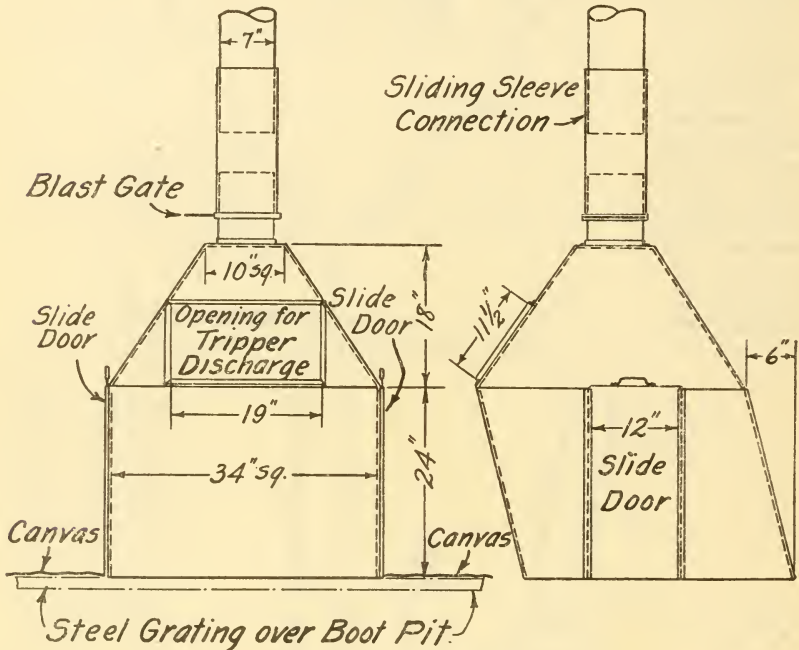

FIG. 8.—Hood for application of suction to boot pits

When grain enters the pit through the grating on the other side of the leg, the opening for the tripper discharge is closed and the dust is drawn up through the section of the grating covered by the hood. Sliding doors are provided on each side of the hood, and a gate valve is placed in the suction line, where it connects with the hood to regulate the suction applied.

In one grain elevator natural vents are used where the belt discharges into the boots. The rectangular vents, more than 12 inches wide, extend over the full width of the belt. Such an installation can seldom be used, but in this particular elevator it was possible to run a vent pipe from a point directly over the belt discharge, vertically through the cement track-shed floor overhead. The duct runs close

to the workhouse wall, to a height of approximately 15 feet, and exhausts above the track shed. This surprisingly effective method is operated by the pressure created by the surplus air in the boot. The duct, however, must offer little friction to the air movement and must be so large that the resistance offered to the upward flow does not exceed the pressure of the air entering the boot with the grain.

IN ELEVATOR HEADS AND LEGS

The most satisfactory and usual method for controlling dust in elevator heads and legs is to run a vent pipe from the elevator head to the outside of the building (fig. 9). Some operators have applied suction to the heads, but most of them have replaced these suction connections by vents. Instead of a connection on the elevator head,

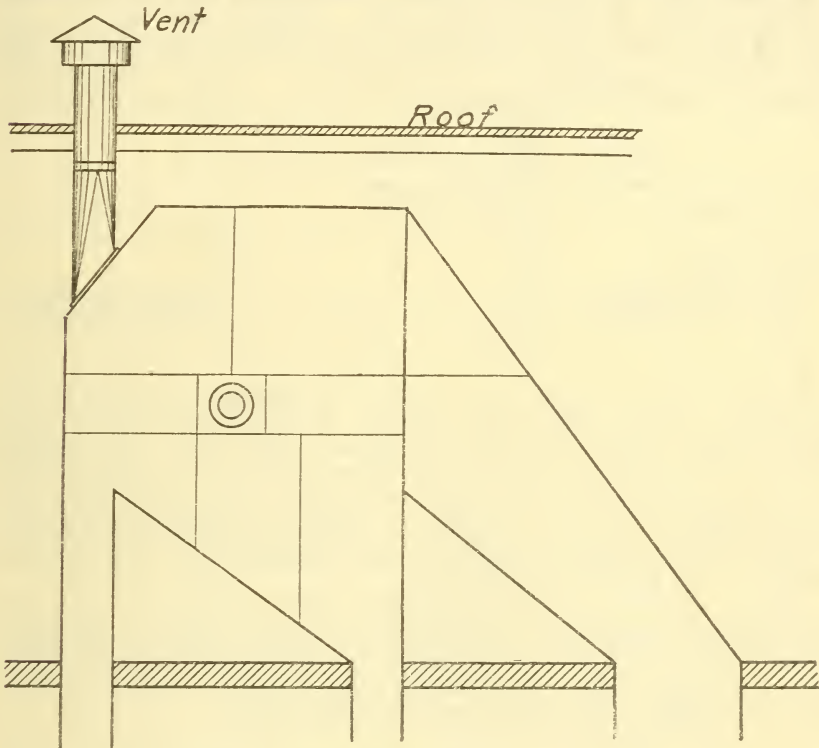

FIG. 9.—Elevator head vent

some installations have a vent pipe leading from the garner to care for the head as well as the garner. In one grain elevator the dust in both the garner and the elevator head is controlled by a vent from the discharge spout near the elevator head (fig. 10).

These many methods of controlling the dust conditions in elevator heads are the result of the difference in opinion concerning the dust and air conditions in an elevator head when grain is being thrown from the elevator buckets into the discharge spout leading into the garner. The prevailing opinion is that a pressure exists within the head and that a vent pipe over the front leg is necessary to relieve this pressure, which is supposed to be produced by the fanning action of the buckets.

Some contend that a vent over the elevator head is unnecessary if the garner is vented. Objection has been made to placing large vent pipes over the elevator heads because of the intimate contact of the grain with humid outside air, which, it is claimed, would change the moisture content of the grain. However, it seems unlikely that the moisture content of grain can be appreciably affected during the short period that the grain is in contact with such air.

Observations were made at three modern elevators having different installations. Air velocity readings were taken under various conditions, by inserting an anemometer in the vent duct and noting the direction of the air flow. The effectiveness of the installation was noted, and observations were made as to whether it tended to draw out grain, chaff, etc., on windy days.

Elevator No. 1.—The anemometer was inserted in a 12-inch vent installed on the elevator head (fig. 9). Readings were taken, on a cold and windy day, when the elevator was not running, when it was running empty, and when it was lifting grain. The air velocity readings and the direction of the air flow in the vent are shown in Table 1.

TABLE 1.—Head vent readings in elevator No. 1

Velocity	Volume	Direction of air flow	Conditions
<i>Ft. per min.</i>	<i>Cu. ft. per min.</i>		
797	627	Updraft.....	Elevator not running.
474	373do.....	Elevator running empty.
531	417	Downdraft.....	Elevator lifting grain.

Elevator No. 2.—In this plant a vent over the discharge end of the head (fig. 10) also served the garner. No velocity readings were taken because the conditions in the garner would affect the readings in the vent. It was observed that, when the vent was placed over the elevator discharge and no garner vent was used, the air flow was outward instead of inward while the elevator leg was lifting grain. A great deal of chaff and dust, escaping through the vent, was deposited on the roof of the building.

Elevator No. 3.—A 24-inch diameter vent was placed over the front leg and capped with a hood similar to those used for ventilating ocean vessels. Velocity readings like those taken in elevator No. 1 and a reading on the corresponding flow of air through the garner vent were taken. The results are shown in Table 2.

TABLE 2.—Head vent and garner vent readings in elevator No. 3

Elevator head vent readings			Garner vent readings			Conditions
Velocity	Volume	Direction of air flow	Velocity	Volume	Direction of air flow	
<i>Ft. per min.</i>	<i>Cu. ft. per min.</i>		<i>Ft. per min.</i>	<i>Cu. ft. per min.</i>		
66	325	Out.....	None.			Elevator not running.
(¹)	(¹)	(¹)	190	596	Out.....	Elevator running empty.
111	545	In.....	435	1,370	Out.....	Elevator lifting grain.

¹ Velocity too low to be recorded.

The results in Tables 1 and 2 show that the air flow up the vent was greatest when the elevator was not running, that this flow was decidedly smaller when the elevator was running empty, and that the flow of air was down, not up, when grain was being elevated. These readings do not bear out the common belief that a pressure exists in the head at all times, and that a vent over the front leg is necessary to relieve this pressure.

To ascertain why the updraft is greatest when the elevator is not running and is reduced when the elevator is running empty, all factors which might tend to produce or change the air movements in the leg when operating were considered. It is logical to conclude that when the elevator is not running, both legs, aided by the ventilating hood on the vent, act as flues for conducting the warmer basement air to the exterior. When the elevator is running empty, however, there is a reduced draft up the vent, because the natural

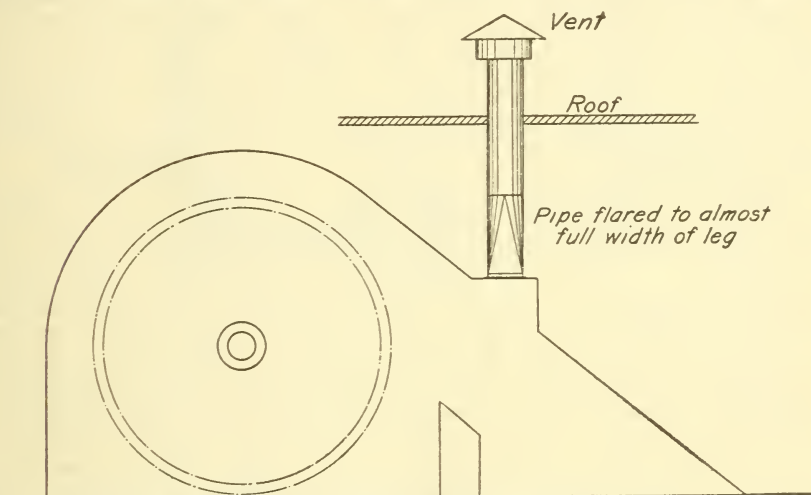

FIG. 10.—Vent on elevator head serving both leg and garner

flow of air up the back leg is disturbed and directed downward and because a large quantity of air from the front leg is recirculated by the fan action of the buckets. Observations have shown also that the fan action of the buckets at the head discharge forces some air down into the garner to escape through the garner vent, thereby reducing the head-vent readings.

A consideration of the air requirements and air supply in the elevator head and legs led to the formulation of a theory which probably accounts for the reversed air currents that are directed down into the head through the vent when grain is being elevated. When the buckets discharge their contents, a certain quantity of air is carried with the grain to the garner through the discharge spout. The space occupied by this air, and also the space occupied by the grain in the buckets, must be filled by the same volume of air. If the garner is vented, the air within the garner which is being replaced by the grain does not satisfy the air requirements of the buckets. Air for these empty buckets must therefore come from some other source.

At first thought the quantity of air required by the discharging buckets may seem negligible, but an elevator handling 15,000 bushels of grain per hour requires 310 cubic feet per minute. Additional air is also carried down the back leg with the buckets. The only natural source of air supply outside the vent is up the front leg. As this leg is partially sealed by grain in the boot, the flow of air up the front leg is somewhat restricted and is insufficient to meet the air needs at the head. To make up this deficiency air enters through the vent. If no vent is provided, a slight negative pressure will exist in the elevator head. Therefore the quantity of air required to replace the grain in the buckets, added to the quantity which goes down the spout into the garner, plus that which goes down the back leg, must equal the quantity which is supplied by the front leg and through the vent to produce an equilibrium.

Where the vent was placed over the discharge, to serve both the head and garner, a great deal of dust, chaff, etc., was discharged through the vent. Such an installation might create a decided shortage in weight because of the large quantity of chaff, dust, etc., exhausted. The reason that so much material is thrown out in this installation is that the air must flow from the garner to the vent through the discharge spout in a direction opposite to the flow of grain and natural flow of the air. Thus dust particles and chaff are picked up from the grain and discharged through the vent.

Although when grain is being lifted the flow of air is inward through the elevator-head vent and outward through the garner vent, the use of an elevator-head vent in conjunction with a garner vent is advisable. A head vent, although not essential as a dust-control measure, serves as a ventilator, which will satisfy the air needs in the elevator head and promote a direct flow of apparently dust-free air with the grain from the elevator head to the garner. It also ventilates the basement when the elevator leg is not in operation. Readings have shown that more than 600 cubic feet of air per minute flows out through a 12-inch head vent over the front leg (Table 1). As a dust-explosion control measure a very large vent is even more valuable in relieving the pressure from an explosion in the leg. Extending the elevator head directly through the roof and capping it with a large ventilator have been suggested as an explosion and dust-control measure. At least two elevators are now equipped in this manner. This method is especially recommended for new grain elevators. The diameter of a vent pipe installed on old equipment should be two-thirds the width of the leg and installed directly over the front leg (fig. 9).

AT GARNERS AND SCALE HOPPERS

The presence of dust on the scale floor is particularly objectionable, because of its effect on the scale mechanism. Grain entering the scale hopper displaces the air already there; and this air, carrying large quantities of dust, will escape into the building unless some provision is made to prevent it. The same conditions exist at the garner.

Many attempts have been made to control the dust so that the weights would not be affected. Air ducts connecting the garner and scale hoppers have been developed to permit the passage of air from the scale hopper being filled into the garner being emptied and vice versa (fig. 11). A more general practice, however, is to inclose the

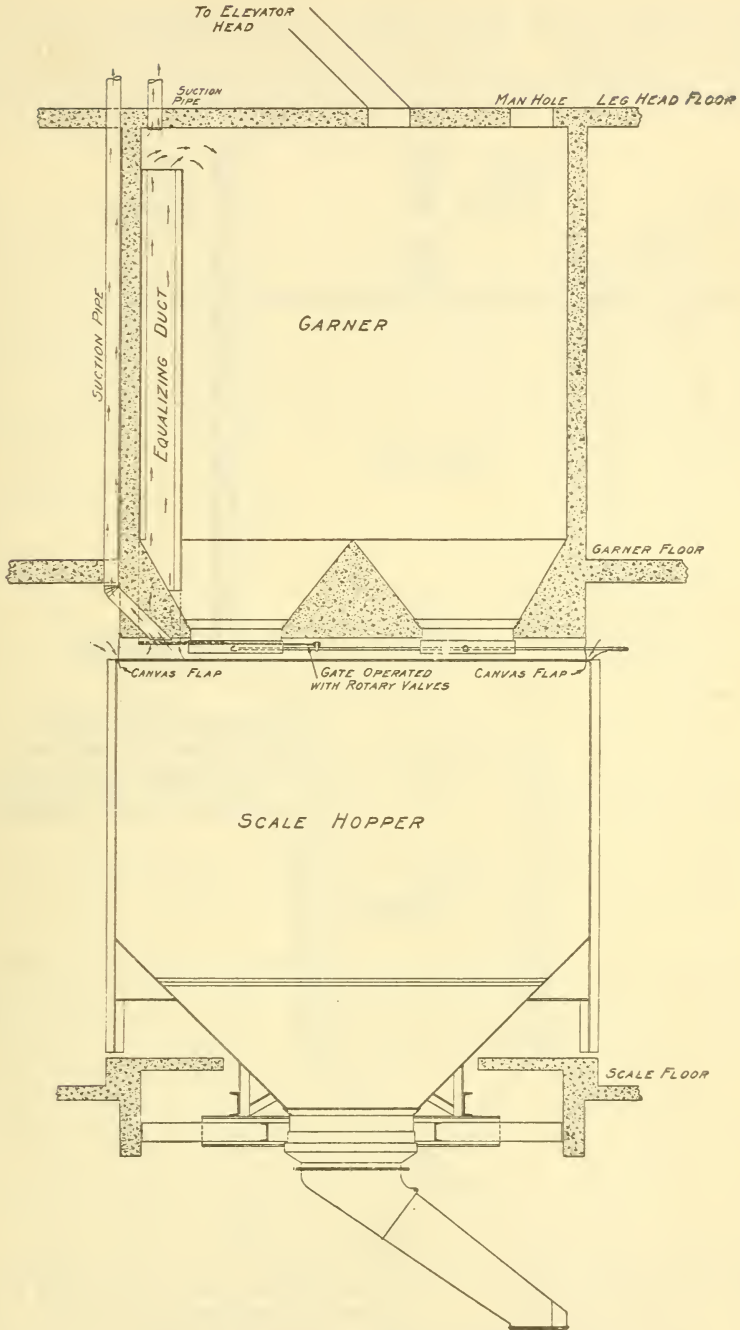

FIG. 11.—Application of suction to scale hopper and garner

space between the garner and the scale hopper with a curtain of cloth, which acts as a filter and permits the air to escape while the dust is retained in the grain. When such curtains are made of loosely-woven cloth, to permit the air to pass through so as not to create a pressure within the scale hopper, the light, fine dust escapes and settles on the

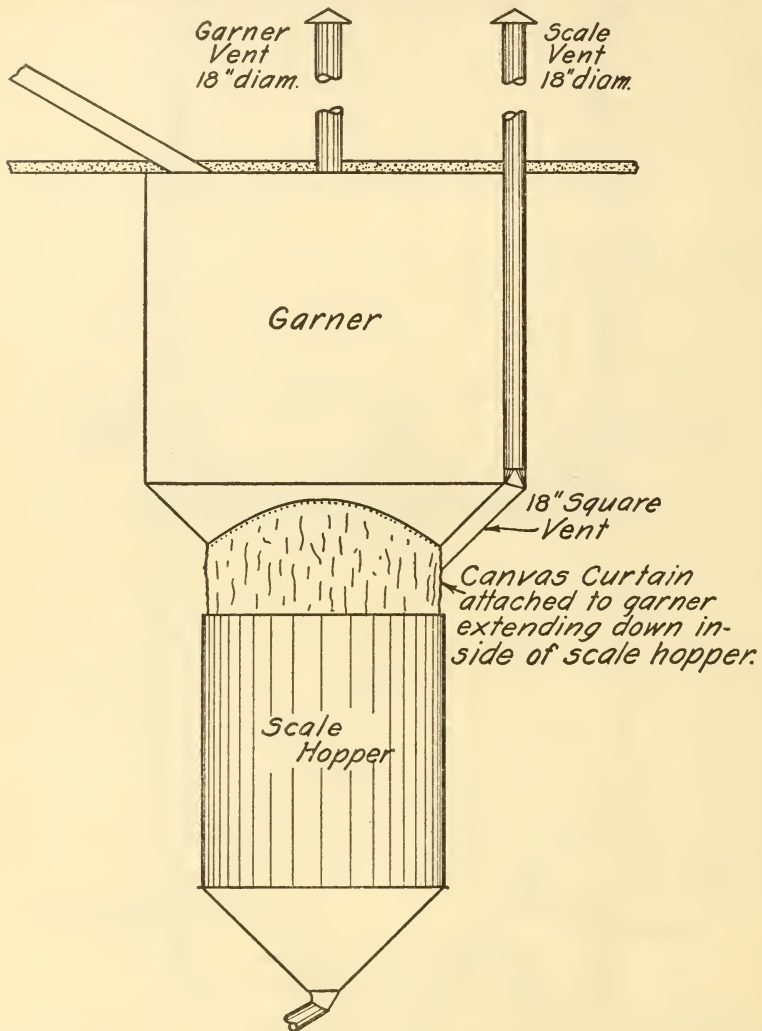

FIG. 12.—Scale and garner vents

scale floor. A curtain of canvas or tightly-woven cloth, inclosing the space between the garner and scale hopper, and a vent pipe leading from this inclosure to the outside of the building, are better. A vertical pipe extending through the roof creates a slight natural draft, so that the light, fine dust which would escape inside the building is drawn outside. This vent pipe should be of sufficient diameter (about

18 inches) to permit the escape of the air without creating an excessive pressure or velocity. On a tightly-covered garner such an installation is very effective in controlling dust clouds. A compact arrangement of vents for both scale and garner, with a canvas curtain inclosing the space between the garner and scale hopper (fig. 12), is an economical way to control the dust.

AT BELT LOADERS

When grain is discharged from a bin hopper or spout onto a moving conveyor belt a cloud of dust is produced by the impact of the grain upon the belt and by the air currents following the belt. Belts are often loaded in a tunnel or basement, places where dust control is particularly important. In most elevators the shipping belts run through tunnels or areaways under the bins and are loaded by fixed spouts. The receiving and transfer belts are usually loaded by fixed spouts, leading from distributing heads or from transfer spouts. Some elevators use movable belt loaders which commonly consist of

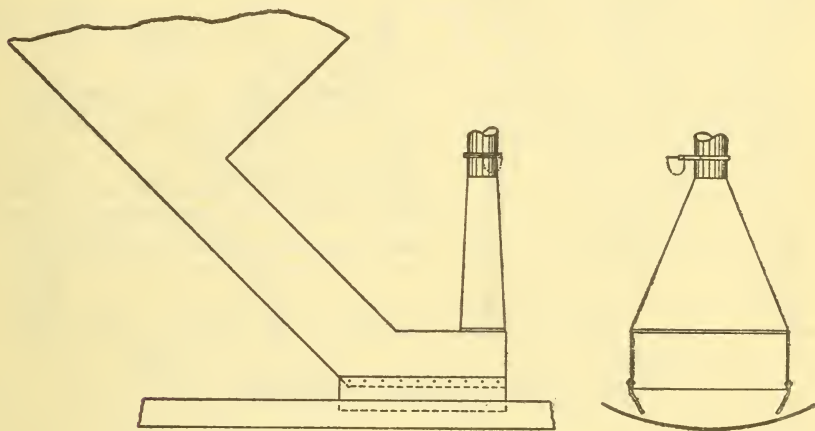

FIG. 13.—Suction hood on belt-loading spout

a covered sheet-iron hopper with a short spout at the bottom extending close to the moving belt. The opening in this spout is controlled by a gate or valve. In operation, the belt loader is placed over the belt in the desired position and grain is fed into the hopper from one or more movable spouts, from other belts, or by hand.

Suction for fixed belt loaders (fig. 13).—A hood at the end of the spout and a pipe connecting it to an overhead trunk line have proved satisfactory. The hood should be flared to the full width of the loading spout and should have the proportions recommended for the United States Department of Agriculture hood (fig. 32). It should be installed so that a choke or spill will not force grain or material into the suction hood. Suction is applied at the belt loaders in only a few elevators, and the installations have not been in use long enough to show all the good and bad features.

Suction for movable belt loaders.—Pipe connections, with a sleeve coupling, can be provided at points where the loader is spotted regularly. The only known method of applying suction at other points

is to provide a hood on the belt loader and connect this hood by means of a flexible hose to the main suction trunk line. Extra time and labor are required to make the connection, and it is generally considered unsatisfactory. A number of manufacturers of mill and elevator equipment are trying to develop a satisfactory method of applying suction to movable equipment. At present the only suggestions that can be made for the control of dust at movable belt loaders are to inclose the loader tight enough to keep the dust from escaping and to provide suction at the discharge spout through flexible couplings.

The choke-feed belt loader is the most satisfactory of all types of belt loaders, because it creates less dust than any other known type. From an operative standpoint it has many advantages, especially in mixing. Very little dust rises from the grain as it is discharged upon the belt, but the little cloud that is formed is cared for by a hood (fig. 14).

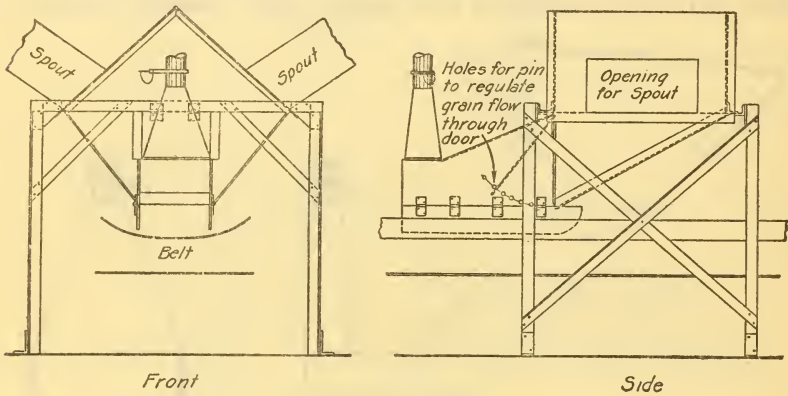

FIG. 14.—Suction hood on choke-feed belt loader

AT TRIPPERS

In a few elevators it is possible to discharge grain direct from the scale hopper or elevator head to the storage bins, but in the larger houses this is generally impossible and conveyor belts with trippers are used. This agitation of the grain while it is being tripped from the belts to the bins stirs up great clouds of dust. It has been difficult to design suitable apparatus to collect the dust at this point. Because the tripper is moved at frequent intervals, a satisfactory connection between the dust-collecting hoods on the tripper and the main suction trunk line is difficult. One method suggested for the solution of this problem provides for the use of specially constructed 7-inch rubber hose to connect the suction line and the movable equipment.

Experiments are now being made with a jointed metal spout, which connects the tripper with a suction trunk line installed directly over the path of travel of the tripper. An automatic means of making the connection between the tripper and the suction line would help to solve the problem. Such an installation must be simple, substantial, and automatic or easily operated.

The individual dust collector has also been suggested. A small fan, mounted on the tripper and operated by the moving belt, produces the suction necessary to collect the dust rising from the grain. The fan discharges into a small cyclone collector, mounted on the tripper, and the cyclone discharges the dust either into the grain entering the bin or into a receptacle, which can be emptied at a floor-sweep opening. The principal objection to this system is the disposition of the exhaust from the small collector. This exhaust air carries with it much light, fine dust, which is difficult to separate from the air and the scattering of which constitutes an explosion hazard. A special collector for this work, which will collect all of the dust, may be developed, but the variation in the volume of dust which it will be necessary to handle at different times makes this difficult. To care for the exhaust of the cyclone it has been suggested that the exhaust pipe be extended into a cupola or monitor running over the path of travel of the tripper. Where closed bins are used it is possible to dispense with the cyclone collector and connect the fans so that they will exhaust into the bin into which the grain is running. In this case it will be necessary to have the bin vented sufficiently to prevent back pressure.

AT BINS

When grain is run into a bin from a spout, conveyor, or belt tripper the air in the bin is displaced and as the air is forced out of the bin it carries with it the dust separated from the grain entering the bin. The filling of a modern grain-storage bin displaces about 40,000 cubic feet of dust-laden air. Exhausting this dust-laden air inside the plant constitutes one of the greatest dust-explosion hazards and makes it almost impossible to keep the elevator properly cleaned. It is difficult to understand why this practice is continued, when the method of controlling the dust is so simple and inexpensive.

To care for the air displaced by the grain entering the bin, a galvanized-iron pipe, 12 inches in diameter, or of such dimensions that the velocity of the air in the pipe will not exceed 500 feet per minute, should lead by the most direct route from the bin to the outside of the building. Where fans installed on trippers exhaust into bins the vent should be larger. Some progressive elevator operators have vented to the outside air every bin in the house. This highly commendable practice is applicable to closed bins only. A hood to exclude rain, snow, etc., should be placed over the end of the vent (fig. 26).

AT DISCHARGES OF CONVEYOR BELTS

When grain is discharged from a conveyor belt, the air traveling on its surface is disturbed and forms a large dust cloud unless some system of controlling it is provided. As conveyor belts may discharge into elevator legs, spouts, or bins, or upon other belts, different methods of dust control may be necessary for the different installations. Equipment designed to collect the dust at points where conveyor belts discharge should collect only the light floating dust and keep the grain from entering the suction hood. When a belt discharges into an elevator boot, a hood at the edge of the receiving hopper of the leg (p. 6) can be used. When the belt discharges into a spout, a hood attached to the side of the spout opening can be used,

although it may be better to inclose both the end of the belt and the spout opening with a hood. Often the discharge end of the belt is just above the floor level, and the hopper or spout into which the grain falls is directly below the floor. In such cases a suction hood (fig. 15) is satisfactory. A similar hood can be used when the belt discharges into a bin, provided the bin opening is small enough to be covered by the hood. If open-top bins are used, such a hood is impractical. A hood installed above and a little ahead of the discharge point of the belt will be valuable in controlling the dust at this point. A feeder is generally used where a belt discharges onto another belt. When this transfer point is fixed, a suction hood can be attached to or installed directly over the hopper.

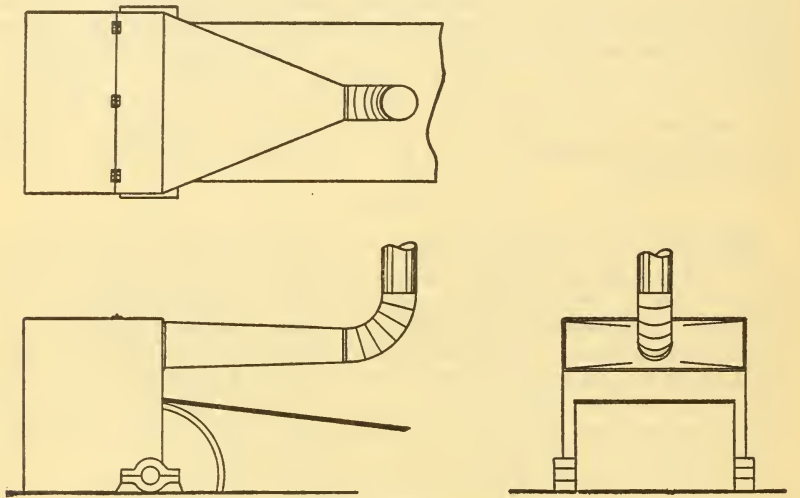

FIG. 15.—Horizontal hood at belt discharge into spout

Natural drafts can be used to control the dust at belt discharges or transfers in only a very few cases. Where a transfer is installed in a tunnel, a vent pipe extending from the hood over the transfer hopper through the roof of the tunnel to the outside air can be used; but it is generally more satisfactory to have the hood at such a point connected to a line in which suction is maintained by a fan.

AT TAILS OF CONVEYOR BELTS

Some chaff and dust always cling to a conveyor belt handling grain after the grain has been discharged. They are deposited at the end of the belt where it passes over the end pulley and some of the light dust is thrown into suspension, unless steps are taken to control it. Some operators consider that the quantity of dust discharged at the end of the belts does not warrant the installation of dust-control apparatus. Others, however, feel that it is more economical to use some mechanical means for removing this material, at the same time collecting the light floating dust, than to have an employee clean it up at intervals. Operators who have taken this view of the matter have developed several hoods for the purpose. One type (fig. 16) consists of a trough-shaped hood at the end of

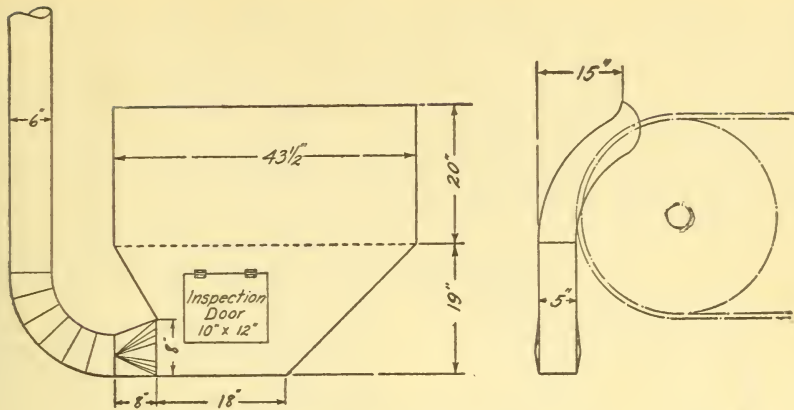

FIG. 16.—Hood at tail of conveyor belt

the belt to catch the chaff and heavy material carried over the tail pulley. This material is carried away through the suction line connected to the hood as fast as it is deposited. Another type (fig. 17) incloses more completely the tail end of the belt and has, in addition to the trough or hopper to catch the heavy material, a slightly flared hood arranged to prevent any light dust from being thrown into suspension at the end of the belt. This hood is especially well adapted for installation at the tail of overhead conveyor belts. Although hoods of these two types may not be adapted to all belt installations, they will serve as a basis for designing others to meet various conditions.

AT MISCELLANEOUS POINTS

It is impossible to enumerate all the places about an elevator where some dust-control measure should be applied, because a dusty point in one elevator may have been eliminated in another elevator

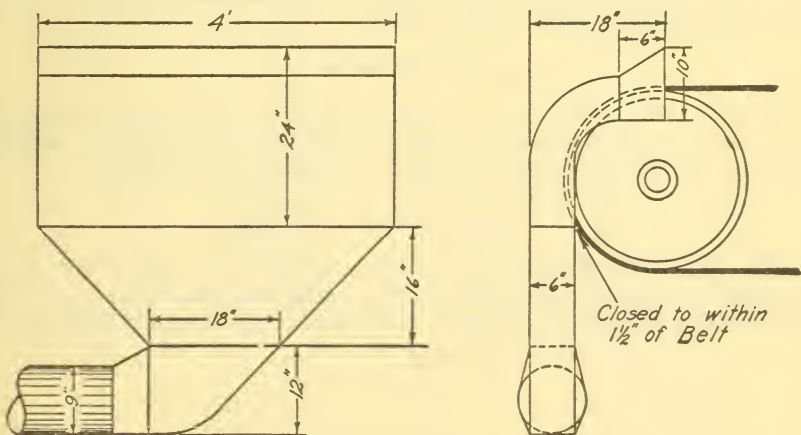

FIG. 17.—Conveyor belt hood

by a difference in construction. The marine tower in elevators where boats are unloaded is usually very dusty, and the control of the dust at this point is given little attention. One elevator superintendent has partially met this situation by installing a vent leading from the garner bin through the roof of the tower (fig. 18). This vent, a 30-inch pipe, capped with a ventilating hood, relieves the pressure created in the bin by the grain discharged from the leg and prevents to some extent the dissemination of dust within the tower. The principle of this installation is the same as that for the installation

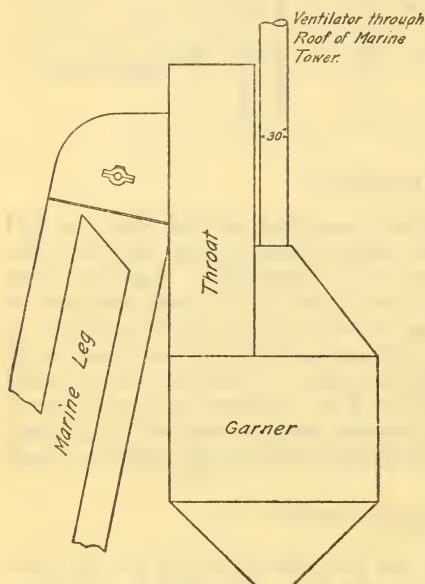

FIG. 18.—Ventilating system in a marine tower

recommended for the control of dust in garner, scale hoppers, and bins. Another point where dust clouds generally prevail is around turn heads or circle spouts on the distributing floor or in the basement, especially where two or more of the spouts are connected or where they enter elevator boots, hoppers, or bins having other spouts leading into them. In such cases the pressure produced by the grain flowing into the boot, hopper, or bin forces dust-laden air out of any open spouts leading from a turn head or circle spout to the same boot, hopper, or bin. A simple way to remedy this condition is to place in each spout a flap valve consisting of a piece of belting, which is so suspended that the spout will always be closed except when grain flows through it. In addition, the boot, hopper, or bin into which the grain is discharged should have dust-control equipment (p. 34).

DUST REMOVAL

Dust accumulations and deposits are removed from the floors, walls, ledges, and equipment of an elevator and conveyed to a central point of deposit outside the plant by a number of methods.

BRUSH-AND-BROOM METHOD

The dust, brushed down from overhead structures by hand brushes, is swept into piles by floor brushes and removed from the building in sacks or baskets or through a chute or spout leading to a

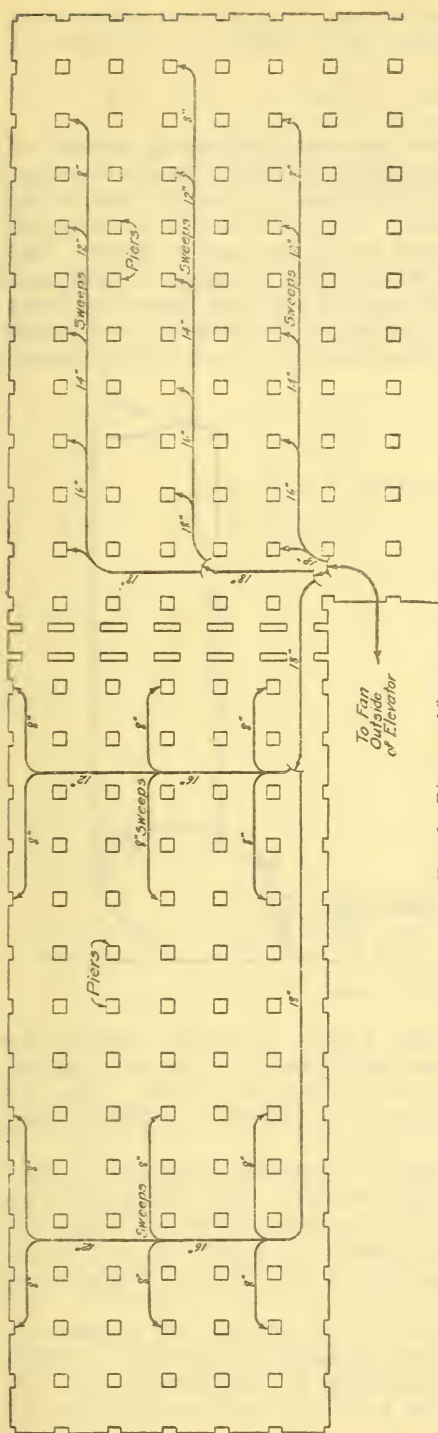

FIG. 10.—Diagram of floor-sweep system
Dust Collector

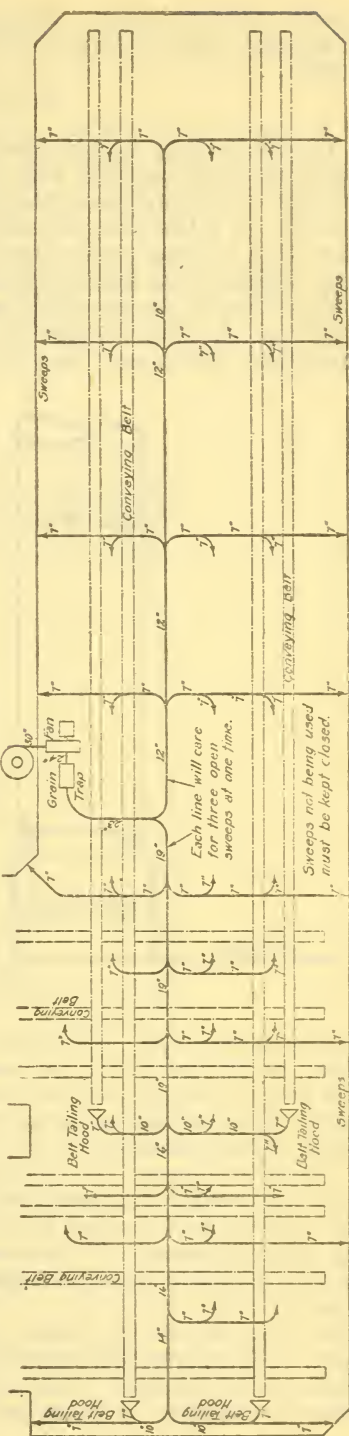

FIG. 20.—Diagram of combined floor-sweep and dust-collecting system

central collecting point. This method not only requires a great deal of manual labor, but it is inefficient and creates a dust-explosion hazard.

FLOOR-SWEEP SYSTEM

The floor-sweep system, the most common mechanical method of removing dust deposits and accumulations from a grain elevator, consists of air trunk lines which lead from fans, preferably outside the elevator, to all sections of the plant. Branch lines run down to the floor level to floor-sweep hoods, into which the dust is swept. The fans exhaust into dust collectors outside the elevator. Sometimes these collectors are mounted on the roof of the dust house, far from the plant. In extensive systems the collectors discharge into a separate fan system, which conveys the collected material to a central collector

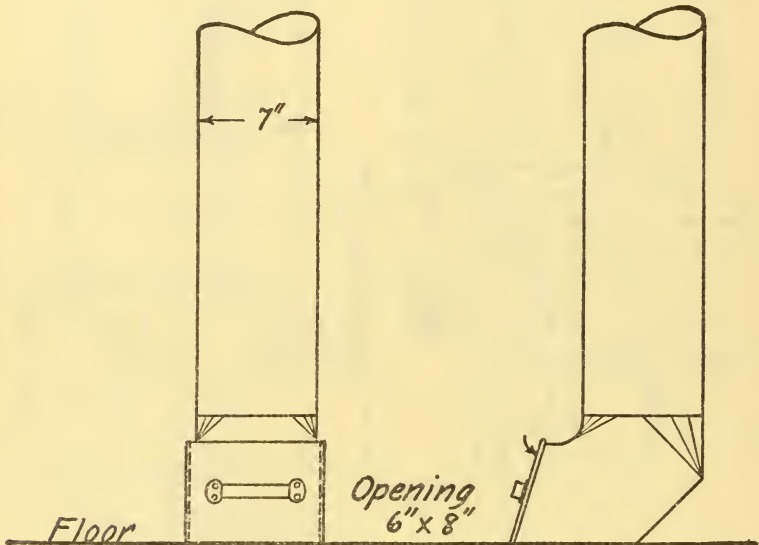

FIG. 21.—Floor sweep

on the dust house. This conveying system is usually outside the plant, for its use within the elevator might result in the propagation of a dust explosion from one section of the plant to another. For the same reason a small separate fan system is desirable to care for each section of the elevator.

The dust is swept, by either brooms or brushes, to the floor-sweep hood, into which air rushes at a high velocity. This air gathers up the material as it is swept into the hood opening and carries it through the piping system. A floor-sweep system is similar to an air-conveying system of the low-pressure type, with the same principles of design.

In the floor-sweep system (fig. 19) the trunk line has a cross-sectional area equal to the combined areas of all the branches in a certain section of the plant. When the cleaning is completed in one section, the suction in the trunk line leading to this section may be

shut off by a swinging valve in the main duct leading from the fan and another trunk line caring for the branches in another section of the plant thrown in, so that the suction of the fan may be concentrated at the point desired.

In some installations a dust-collecting system is incorporated in the floor-sweep system (fig. 20). This is not adapted for applying suction to boots, elevator heads, garners, and scale hoppers; it can be used in caring for the tails of conveyor belts and, in some cases, at belt loaders.

As much grain is handled by a floor-sweep system, grain traps are placed in the main duct ahead of the fan to recover the grain from the dust. In some installations the material from these traps is spouted or elevated to a screening bin, which feeds into a special

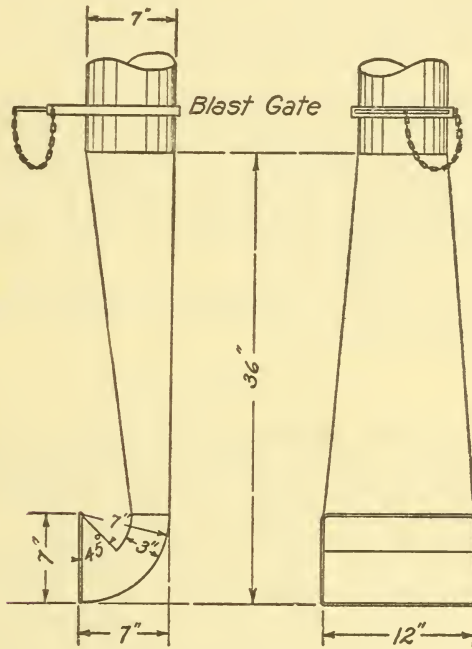

FIG. 22.—Improved floor sweep

grain cleaner, to separate the various grains of value. In most installations, however, the grain falls from the trap upon the floor, where it is bagged at frequent intervals.

Floor-sweep design.—A poorly designed sweep can greatly reduce the efficiency of the floor-sweep system because it can not rapidly gather up the material swept into the hood. In sweeps of the type usually installed (fig. 21) a hinged cover is placed over the end to shut off the suction not in use and a blast gate in the branch line is sometimes used instead of the cover. A sweep designed in the Bureau of Chemistry (fig. 22) to remove material very rapidly without choking operates on the principle of having the air come in more intimate contact with the material than it does in the usual installation.

COMPRESSED AIR

Compressed air is necessary for cleaning certain equipment around an elevator, especially motors, from which it is difficult to remove the dust in any other way. A few operators have adapted the compressed-air system for general cleaning. A long pipe, with an elbow at the upper end, or a compressed-air hose line attached to a pole is used to blow the dust from overhead structures which can not be easily reached with a broom or brush. This method of cleaning, however, creates a dust-explosion hazard and is inefficient. The dust blown from overhead forms in clouds, making it necessary constantly to guard against the ignition of these clouds as the dust settles to the floor. Moreover, the dust must be brushed from the machines or the floor, where it settles after being blown from overhead. Overhead lodging places for dust should be reduced to a minimum and compressed air should be used only for cleaning the motors or other similar surfaces which can not be satisfactorily cleaned in any other way. The elimination of overhead ledges reduces cleaning to a minimum.

Compressed air should be handled carefully when it is used for cleaning in plants where the dust-explosion hazard exists. The cleaning should be done while the plant is not operating and care should be taken to see that the windows and doors are open so that the building is well ventilated. Special care should be taken to eliminate all possible sources of ignition while the cleaning is in progress or while the dust remains in suspension.

The use of steam instead of compressed air, which has been employed in some industries with varying degrees of success, may be adapted to some parts of grain elevators.

VACUUM-CLEANING SYSTEM

The adaptation of the vacuum-cleaning system to grain elevators for dust removal may still be considered in the experimental stage. The general arrangement of such systems, however, is sufficiently well standardized to warrant a general description.

The system must be capable of handling heavier material than the ordinary vacuum-cleaning system can handle, because grain and foreign material must be rapidly picked up with the dust. More rugged fittings are needed in a modern concrete and steel elevator to withstand the extra wear and the rougher treatment. Theoretically, the vacuum-cleaning system is the best for a grain elevator or any other plant where the dust-explosion hazard exists, because it removes the dust without the formation of dust clouds in the building and the dust can be drawn out of cracks and crevices, where it would not otherwise be reached.

In general arrangement a vacuum-cleaning system for a grain elevator resembles the ordinary vacuum system used in hotels and public buildings. The essential parts are a vacuum producer, a network of piping leading to all parts of the building, with suitable inlets or hose connections, hose, nozzles, and a collector or dust separator, installed in the main line to catch the dust before it enters the vacuum producer. All of these parts must be well designed and carefully installed.

The air pressure and velocity needed are important questions. A few tests have shown that ordinarily a vacuum-cleaning system should be operated at a negative pressure sufficient to produce a static pressure or head of at least 2 inches of mercury at the inlet or tap farthest from the vacuum-producing equipment, when this tap and a number of other taps corresponding to the number of hose lines to be operated at one time by the system are open. With a static head of about 2 inches of mercury, the air entering a 2-inch tap opening had a velocity head of 13.5 inches of water, or a velocity of 14,700 feet per minute. Owing to friction, this air velocity is greatly reduced after a hose is attached to the tap. For example, assuming that one velocity head is lost in 50 pipe diameters of hose length, six velocity heads are lost in a 2-inch diameter smooth-interior hose 50 feet long. No tests were made to determine the velocity of air entering the hose; but, with a static pressure of 2 inches of mercury at an open tap, a well-designed cleaning nozzle connected to a 2-inch hose 50 feet long, operated satisfactorily. If a 2-inch static head is maintained at the farthest tap, a higher velocity will advantageously exist at the taps nearer the vacuum-producing equipment.

At least 325 cubic feet of air per minute is required for each 2-inch hose connection used at one time. Based on a velocity of 15,000 feet per minute at the tap openings, this value may appear excessive, but an even higher value may be advisable to compensate for the wearing of the equipment and to permit the cleaning of the piping by the opening of clean-out valves in the main pipe lines.

The working pressure at the vacuum-producing equipment must be the pipe friction losses from the most distant taps to the producer plus the loss in the collector plus the static pressure at the tap. The friction of the air, even in straight pipe, is a source of loss. Since the friction loss varies as the square of the air velocity and the roughness of the pipe and as the length divided by the diameter of pipe, care should be taken to make the main pipe lines of sufficient diameter to give a velocity which does not result in an excessive loss and to have the small-diameter branch lines as short as possible. The main lines should be so designed that the velocity of the air will not drop below 5,000 feet per minute under any possible operating condition. To maintain this minimum velocity and prevent excessively high velocities, it may be necessary to operate the system with one or more taps open or a like number of nozzles always in use. Bends and turns in the pipe line will produce a drop in pressure, and the friction loss caused by them is usually based on the equivalent loss in length of straight pipe. The loss due to a bend with a radius equal to the diameter is equivalent to the loss in about 15 diameters of straight pipe. All fittings should be of the long-radius type, and 45-degree laterals or 90-degree long turn "y" branches should be used wherever possible. It is best to have all fittings of the cast-iron drainage type, with recessed threads providing for the butting of the ends of the pipe against the shoulders of the fittings, thus making a smooth interior with no pockets or obstructions.

Only piping and fittings with smooth interior surfaces should be selected. In making a joint, the pipe should be cut square and carefully reamed, so that no obstruction is offered to the flow of air.

In making a flange joint, the pipe should be flush with the face of the flange and the gaskets should be cut to match the interiors of the two pipes being connected.

The location of taps or inlet valves for the connection of the hose lines deserves consideration. After the main branch lines are planned to reach all sections of the plant, the short leads or taps should be spaced or placed so that the greatest distance from any point on the floors or walls where the cleaning nozzles are to be used to the nearest tap is not greater than the effective working length of the hose to be used with the nozzles. Twenty-five and 50-foot lengths of hose are ordinarily used, although it is advisable to standardize on one length. The shorter hose is preferable, because of its greater portability and the heavy friction losses in hose lines. Care should be taken to place taps so that the hose can be attached for cleaning in pits or on balconies without climbing up or down to make the connection. Taps should also be arranged to eliminate the necessity of running the hose over or under conveyor belts, which may be in operation when the cleaning is being done.

The selection of suitable hose for use with a vacuum-cleaning system depends to a certain extent upon the place where it will be used and the way in which it will be handled. A smooth interior helps to reduce friction losses, but the hose ordinarily used with vacuum-cleaning systems will not withstand the rough treatment received in an elevator or industrial plant. An attempt has been made to use metal hose, because the friction loss would be less than with rubber hose; but it wears out quickly. Moreover, it is heavy and difficult to handle. The spirally reinforced rubber hose stands up best under the rough treatment, but the friction losses with it are high. The development of a hose with a smooth interior, which is also capable of withstanding the rough treatment received around an industrial plant, will add to the general efficiency of the vacuum-cleaning system.

The nozzle is the most important part of a vacuum-cleaning system. Nozzles of many kinds and combinations of brushes and nozzles have been tested. A satisfactory nozzle is one which will operate rapidly on a concrete floor or wall and gather up everything from grain and strings to pieces of concrete and even dust which has adhered to the floor because of dampness. The nozzle should rest on the floor in a natural operating position, so that the workman will not need to hold it at different angles to insure its successful operation. Bristles or a scraper may be necessary on some nozzles to loosen adhering material. A successful vacuum-cleaning nozzle has been designed and patented by the United States Department of Agriculture (fig. 23).³

The collector or separator must be capable of handling large quantities of air and dust and heavier material. In some installations, two separators or a collector and a separator are used.

A partial separation in a collector or trap removes the heavy material, while the lighter dust passes on to a filter, where it is separated from the air, which passes on to the vacuum producer and is exhausted outside the building. Collectors and filters of several types are made. Some have a large expansion chamber, with

³J. O. Reed, "Improved Nozzle for Cleaners," published in *American Elevator and Grain Trade*, (August 15, 1924) vol. 43, no. 2, p. 113.

baffles or a cone-shaped collector, which separates the heavier material by centrifugal action. Screens may be substituted for baffles in the expansion chamber, or a combination centrifugal separator with a cloth filter may be used. Data to indicate which type is preferable are not available. The separator in one system consists of a metal tank divided into compartments, with a hand-operated valve, which diverts the stream of dust-laden air to one compartment as the other is being emptied. The filter consists of a tank, with a number of filtering screens which separate the dust from the air. An automatic device shakes the dust from these screens to the cone-shaped bottom of the tank, where it is discharged through a rotary air lock. This lock, which is simply a paddle wheel

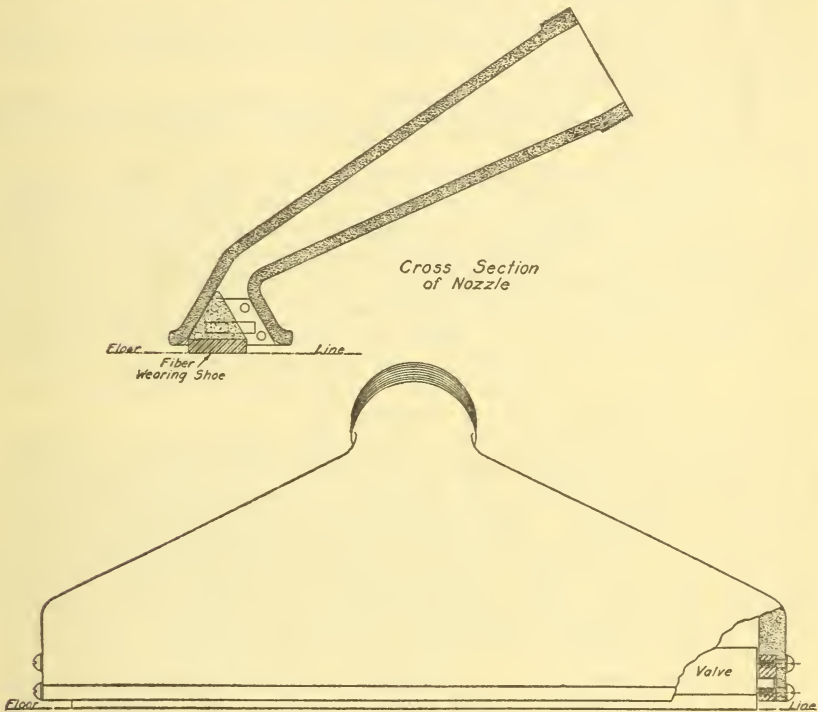

FIG. 23.—Vacuum-cleaning nozzle

revolving in a tight-fitting cylinder, permits the continuous discharge of the dust while a partial vacuum is maintained in the filter.

Dependability is the first consideration in selecting the vacuum-producing equipment to supply the required suction. In a plant operating 24 hours a day most of the equipment is operated intermittently, but the cleaning system must operate continuously. Even on Sundays and holidays and during shutdown periods, attention is given to cleaning. The equipment should operate continuously over long periods with the minimum of attention. Multi-stage vacuum producers of the centrifugal fan type and positive pressure blowers have been used satisfactorily. When the producers are electrically driven, the motors should operate continuously with-

out heating. This part of a vacuum-cleaning system should be arranged in units wherever possible, so that one piece of equipment can be cut out for repairs without impairing the efficiency of the entire system.

ADVANTAGES AND DISADVANTAGES OF DUST-REMOVAL SYSTEMS

The advantages and disadvantages of the cleaning systems here described should be carefully considered before the equipment is installed. Sometimes the cleaning requirements may not justify the expenditure of a large sum of money for an expensive cleaning system; the saving in labor and insurance charges would not be sufficient to provide a fair return on the original investment. To be economical, the installation must reduce the number of men employed to keep the plant clean and also cut down the dust-explosion hazard enough to reduce insurance rates.

In small plants, which are cleaned only periodically by laborers or the regular employees during their spare time, brushes and brooms are generally used.

The advantages of the broom method—low initial cost of equipment, low cost of upkeep, low operating cost, and general adaptability to various conditions—are generally outweighed by its chief disadvantage—that the fire and dust-explosion hazard is greatly increased during sweeping. Moreover, it is difficult to remove the dust from corners, cracks, or crevices with brooms; the collected material may be scattered by drafts over the section already cleaned. The dust thrown into suspension later settles, necessitating a second cleaning. Some method must also be provided for removing the dust from the building after it is swept up.

The greatest advantage of the floor-sweep system over the brush-and-broom method is the facility with which the sweepings are removed from the building and the fact that no additional labor is required for this work. Less sweeping is required because the inlets of the system are at points where the dust generally accumulates, making it unnecessary to push or sweep large quantities of dust for any great distance. The disadvantages of the floor-sweep system are practically the same as those of the broom method. Brooms or brushes must be used to sweep the dust to the inlet of the system. The light dust thus stirred up creates an explosion hazard and dust can not be easily removed from cracks, crevices, and corners. This system is the one generally used.

Although vacuum-cleaning systems have not been entirely satisfactory in the few grain elevators and feed plants where they have been installed, it is generally admitted that their failure has usually been due to defects in design and installation. The indications are that the newer installations in grain elevators will be satisfactory.

The vacuum system is undoubtedly a safe method of cleaning, and it is far more efficient than any other method. The suction lifts the dust out of cracks and pits that brushes pass over, thus making a surface much cleaner than is possible with a brush or broom. The greatest advantage of pneumatic cleaning, however, is the elimination of the hazard of suspended dust. Instead of stirring up the lighter material, it draws the accumulation into the system, thus preventing

the formation of explosive dust clouds at the point of cleaning and the scattering of fine dust to other parts of the plant. On the other hand, the cost, both initial and operating, of a vacuum-cleaning system is high.

The following points should be considered in the adoption of vacuum cleaning for grain elevators: Reduction in fire and dust-explosion risk; reduction in insurance; original cost of the system, including installation charges; cost of operation, including depreciation charges, power, replacements, repairs, and upkeep; cost of transporting collected dust to place of disposal; wages of workmen necessary to keep the house clean; house loss or difference in weights on in and out shipments directly attributable to the cleaning system; health condition of the employees; sanitary condition of the plant; effect on efficiency of the employees.

The relative value of these points will vary with the size of the system and the market for the grain dust collected and whether the cleaning is done by a special force of sweepers or by the regular elevator employees. The advantages of vacuum cleaning will probably give it preference over other systems under consideration, especially where the value of the plant in which it is installed is so great that the protection from fire and explosion afforded by the vacuum-cleaning system justifies the original installation cost. Improvements in equipment and reductions in manufacturing costs will soon make it profitable to install vacuum cleaning in most plants, in many of which the expenditure might not now be justified.

NATURAL VENTILATION

DOORS

Large doors are often desirable, especially on the work floors and track sheds of grain elevators where dust is stirred up during the unloading, loading, cleaning, or conditioning of grain. Rolling curtain doors have been recommended for such places. Wherever possible doors should be arranged on opposite sides of the building in such a way that the greatest possible quantity of air will pass through the building. Such an arrangement not only ventilates the plant but keeps a large section of the floor clean, because of the wind which blows through the building.

WINDOWS

The workhouses in modern plants have many large windows. Windows on opposite sides of the building permit the wind to pass through, thus removing dust from girders, ledges, machines, or overhead structures. Ventilating sash or butterfly windows make ventilation possible during rainy weather.

In some Canadian elevators a number of sashes are connected to a common shaft and opened or closed in unison. A slight pressure upon the sash from within opens any sash up to its maximum of 90°, which permits an employee to obtain additional ventilation at any point. An explosion in an elevator equipped with this device proved that the increased pressure within the building is quickly released by the forcing open of the windows. Once opened, however, the windows can be closed only by operating the control shaft.

LOUVERS

Louvers, either fixed or adjustable, may be used to provide ventilation where doors and windows are impracticable. They prevent any strong direct drafts across the area being ventilated and at the same time provide for the admission of fresh air. Except in places where windows are likely to be frequently broken, louvers are not so desirable as windows.

STATIONARY ROOF VENTILATORS

Ventilation by the use of monitor roofs is an improvement over the ordinary skylight, because windows can be opened on two sides of the monitor, and the wind passing through takes out the warm air which has risen to the top of the building. The fixed-type ventilator for installation on the roof (fig. 24) usually consists simply of a flat metal cone, supported slightly above or within an open metal cylinder somewhat larger than the ventilating pipe to which it is attached. Wind blowing from any direction will operate the ventilators, provided they are properly installed. The tendency of warm air to rise to the top of the building also contributes to their operation. Thus their operation costs very little. With a wind velocity greater than 800 feet per minute, the velocity in the pipe of ventilators of the better class will be more than 50 per cent of the wind velocity.

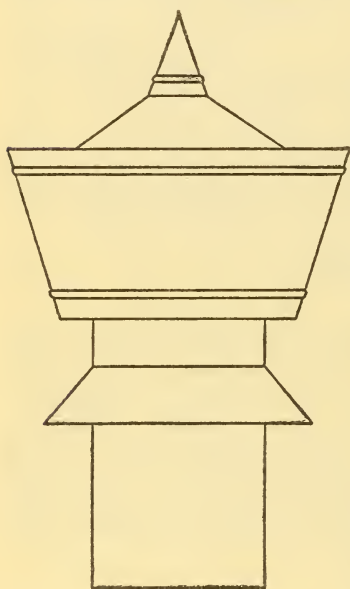

FIG. 24.—Ventilator

REVOLVING ROOF VENTILATORS

The revolving or swinging hood (fig. 25) operates on the same principle as the stationary roof ventilator, but it accomplishes its object in a somewhat different way. In the stationary type the wind currents are deflected past the ventilator opening in such a way that a low-pressure area is created at the outlet and a light suction is created in the ventilator piping. In the revolving

type the action of the wind on a vane attached to the hood turns the ventilator so that the opening is always on the side opposite to that from which the wind is blowing. The wind passing the opening creates a low-pressure area and a light suction in the ventilator pipe.

PRESSURE VENTILATORS

As a rule the ventilators for bins, garner, and equipment (fig. 26) are very simple. The pipe from the bin, garner, or hopper is extended through the roof and curved or formed like a gooseneck to keep out rain, snow, etc. These ventilators depend upon increased pressure within the bin or hopper for their successful operation. Grain entering closed bins, hoppers, or garner displaces the air already there,

and this dust-laden air escapes through the vent to the outside of the building. Ventilators of this type are especially well adapted to closed bins, garners, hoppers, and inclosed equipment; they are sometimes used also at the head of elevator legs or the ends of conveyor belts, where the air currents following the belts create a slight pressure, which is relieved through the vent.

FLOOR VENTILATORS

Floor ventilators are installed only in galleries or passageways where the wind has a chance to blow in several directions beneath the floor. Installing a grating and arranging wind-deflector plates beneath the opening afford a large amount of ventilation when the wind is deflected up through the floor opening. An ordinary ventilator is installed in the roof of the gallery or passageway directly above the floor grating.

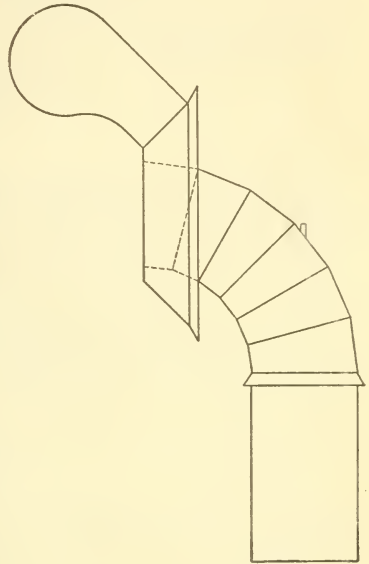

FIG. 25.—Revolving ventilator

INTERSTICE BIN VENTILATION OF BASEMENT

In a modern large elevator, one of the most difficult places to ventilate is the basement of the storage section, especially if it adjoins the workhouse. When the storage section is large, ventilation from the sides is not effective throughout the basement. Two modern elevators use an interstice bin as an airshaft to ventilate the center of the basement, the walls of the bin being extended through the elevator roof and covered with a cone-shaped roof.

In one elevator, three open interstice bins, evenly distributed through the center of the storage section, ventilate the interior of the storage basement. No fans are used to promote the flow of air up through the shafts. The natural draft is considered sufficient.

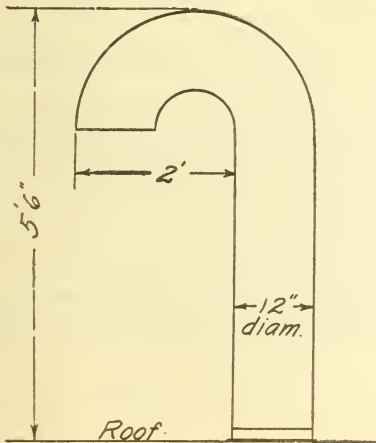

FIG. 26.—Bin vent

MECHANICAL VENTILATION

DISC VENTILATING FANS

Disc fans are well adapted for the ventilation of the basement and other sections of the elevator where natural ventilation methods can not be used. An air inlet or open areaway to the exterior is provided at a point where the air traveling from the opening to the fan passes through the dustiest section of the house. As large quantities of air must be handled, the larger the fan the better.

INTERSTICE BIN FANS

Where only one interstice bin in the center of the storage section is being used as an air shaft, mechanical ventilating equipment has been used to increase the natural ventilation. The air is drawn from the basement and forced outside through this large air shaft by means of a fan large enough to effect at least one air charge per hour. The air forced out of the basement through the air shaft is replaced by fresh air coming in through the windows and doors at the side of the storage section.

DUST-CONTROL EQUIPMENT

FANS

The steel-blade exhauster fan, of the most rigid construction, is generally used. The blades should be so well fixed that they can never work loose to produce a spark. This is best done by fastening the sides of the blades to heavy steel-plate flanges. The blast-wheel should be overhung, so that the material passing through the fan does not come in contact with the ball or roller bearings.

The diameter of the fan inlet should be at least as large as that of the main suction pipe, which should have an area equal to the combined area of the largest number of branches it serves at one time. A fan and a main duct from 10 to 20 per cent oversize will provide for additional branch lines which may be attached to the system.

The speed of the fan depends upon the static or suction pressure required at the fan inlet to overcome the friction losses resulting from the air traveling through the longest pipe line at a velocity of at least 4,000 feet per minute. The speed of the fan and the power requirements must be accurately determined in selecting a motor. The pipe friction losses plus the losses in the collector and grain catcher must be computed to determine the working pressure and speed of the fan. Information concerning the method of calculating the static or suction pressure required at the fan, together with data on the performance of fans, can be obtained from fan catalogues. Fan manufacturers will give advice as to the proper size and type of fan and motor.

PIPING SYSTEM

Short, direct pipe lines, with as few elbows as possible, are most efficient.

The area of the duct at the fan inlet should be equal to the combined areas of the branches served; and, immediately beyond each point where a branch joins it, the area of the duct should be decreased by an area equal to that of the branch line. A main duct with an area from 10 to 20 per cent greater than the sum of branch areas, sometimes recommended, reduces the friction losses in the pipe lines; but it also reduces the velocity in the main duct, so that the dust is not carried through the main duct when only a few of the branches are being used. The dust which settles on the bottom of the main duct is an explosion hazard.

The radius of each elbow in both branch and main pipes should be from one and one-half to two times the diameter of the pipes. In practice the friction of such an elbow is considered equivalent to 10 diameters in length of straight pipe. The friction in an elbow with a short radius may cause a loss as great as that in 60 to 70 diameters of straight pipes. The elbows should be of metal several gauges heavier than that used in the straight pipes. All joints should be soldered to prevent leakage and loss of power.

The piping should be smooth and free from dents. The lap at the joints should be so formed that the flow of air is not obstructed. The piping should be at least 6 inches from the wall, so that the outside of the pipe can easily be kept clean. Handholes should be provided at frequent intervals in the duct, and traps should be placed wherever there is a tendency for material to settle. In vertical lines a trap or boxlike chamber should be placed at the base of the line to catch heavy particles, which can not be lifted by the air. All trunking should be grounded at 50-foot intervals for the removal of static electricity.

The branches should enter the main duct at as small an angle as possible, never more than 45° . The branches should join at the side or the top of the main, never at the bottom. They should never enter the main opposite each other. The branch connection to the main should be as smooth as possible.

DUST COLLECTORS

The metal cyclone dust collector is the most satisfactory type of collector for either a dust-collecting or low-pressure dust-removal system. These collectors separate the dust from the air by means of centrifugal force and air expansion. Baffle plates are usually placed within the collector to control the conditions within the collector necessary to effect a more perfect separation. The most suitable collector makes the best separation with the least back pressure on the fan. The larger the collector, the better will be the separation and the less the back pressure on the fan and the power consumed.

Under no circumstances should a collector be installed inside an elevator. It should be mounted on the roof of the dust house or at some other outside point. Each collector should have its individual exhaust pipe; a common exhaust line permits flame communication from one system to another and so constitutes an explosion hazard.

The exhaust of the collector should be covered with a hood designed to prevent the entrance of sparks. The dust-discharge opening should be large, so that the collector will not choke. A manhole should lead to the interior of a large collector.

GRAIN TRAPS

A grain trap (figs. 27 and 28) is simply an air-expansion chamber in the main duct, so designed that the air velocity through it is too low to carry grain. The grain, stopped by baffles within the trap, falls into the hoppers bottom of the trap. Tandem flap valves covering the bottom permit the continuous discharge of the material without affecting the pressure within the system.

SUCTION REGULATORS

Equipment designed and tested by the Bureau of Chemistry (fig. 29) places a dust-collecting installation under the absolute control of any agency that has supervision over the weighing of grain. The United States Department of Agriculture hood (p. 37) does not pick up grain or light material with a high air velocity in the branch pipe.

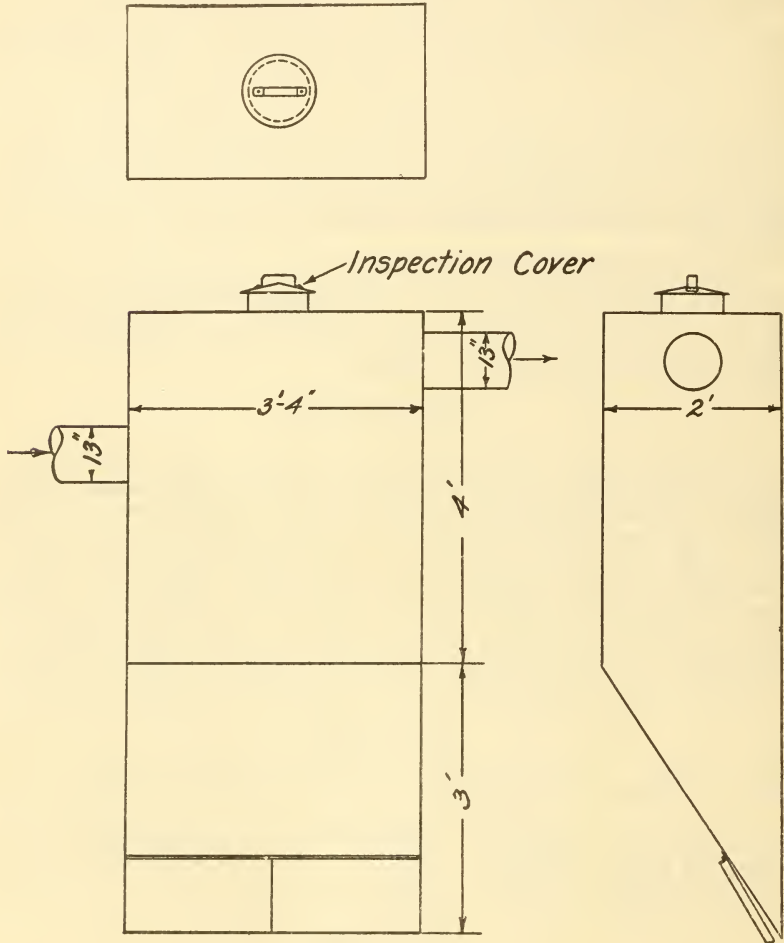

FIG. 27.—Grain trap

The United States Department of Agriculture inspection trap (p. 44) shows the inspector the nature of the dust which is being drawn into the hood. The United States Department of Agriculture air-velocity control valve (p. 45) enables the inspector to control the air velocity in the branch line so that the dust-collecting installation will operate satisfactorily.

UNITED STATES DEPARTMENT OF AGRICULTURE HOOD

The use of a properly designed hood insures a permanent control of the air currents at the point of suction application, because the velocity maintained in the main lines is reduced until the velocity

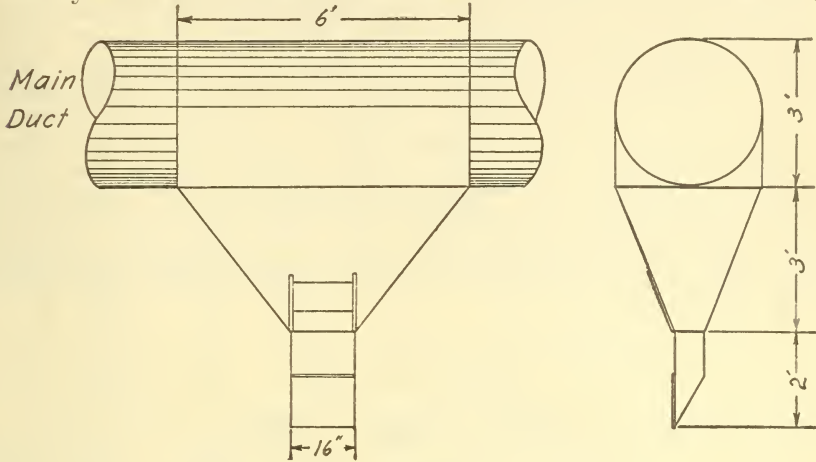

FIG. 28.—Grain trap

at the hood intake is too low to pick up grain, chaff, or other material which might affect the weight.

Experiments to determine the velocities at which various grains are lifted were conducted at the United States Department of Agriculture experimental farm at Arlington Va.

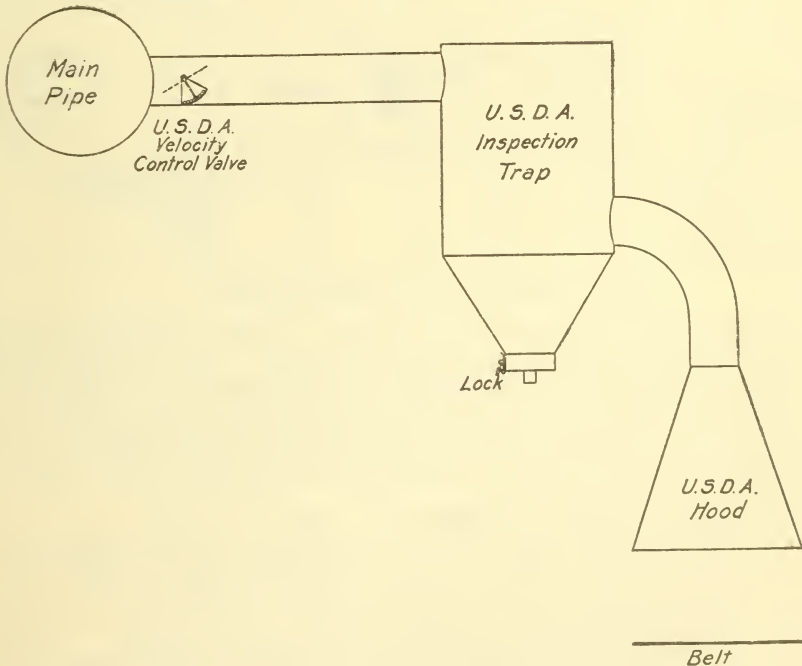

FIG. 29.—Controlled application of suction

The equipment (fig. 30) consisted mainly of a cast-iron exhaust fan with a 9-inch inlet, driven by an electric motor and operated at about 2,700 revolutions per minute. A grain trap, with a cross-sectional area ten times the area of the 9-inch duct, was installed in the pipe line to the fan inlet. To measure the velocities at which the various grains were lifted, a hood, 12 inches in diameter, was placed at the end of a 9-inch pipe leading to the grain trap. The grain was placed upon a tightly drawn No. 14 mesh copper screen 9 inches from the open bottom of the hood. A thin celluloid guide, 6 inches in diameter and 2 inches high, was fastened to the screen to keep the grain on the screen where the air velocity was fairly uniform and where the velocity readings were to be taken by a pitot tube. The guide was divided into four sections to keep the grain evenly distributed over the screen. The pitot tube readings were taken in the center of these four sections, about $2\frac{1}{2}$ inches above the screen.

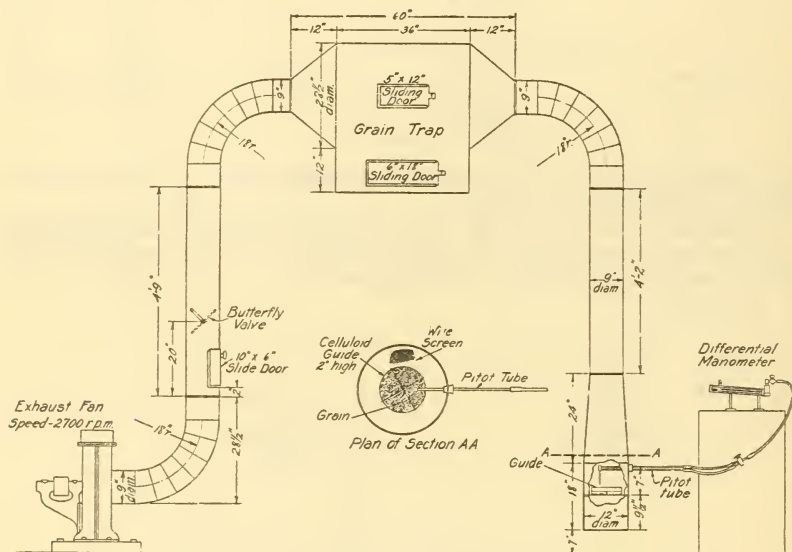

FIG. 30.—Equipment used for air-velocity experiments

Preliminary experiments showed that the air velocity was practically uniform at all points inside the guide. The total and static pressure readings of the pitot tube were taken with a differential manometer, graduated for readings in thousandths of an inch. Oil containing a red dye and having a specific gravity of 0.83 was used instead of water in order to make the manometer more sensitive and more easily read.

One hundred kernels of grain (corn, wheat, or oats) were placed inside the celluloid guide. In the first run the air velocity was regulated by a butterfly valve and slide door near the inlet of the fan, so that all the grain in the guide was just lifted from the screen. Pitot tube readings were taken to determine the velocity. In the next run the grain was replaced in the guide as before and the air

velocity was reduced slightly by opening the slide door near the fan. After the fan had run for about five minutes with the velocity at the hood constant, the air velocity readings were taken and the fan was shut down. Repeatedly, in this manner, the velocity of the air was slightly reduced, and readings were taken until no kernels of grain were lifted from the screen. Particular care was taken to obtain the highest velocity which would not lift the grain. The results of these experiments are given in Tables 3, 4, and 5.

TABLE 3.—Air velocity for lifting oats

Static head	Total head	Velocity head	Velocity	Grain lifted	Remarks
<i>In. water</i>	<i>In. water</i>	<i>In. water</i>	<i>Ft. per min.</i>	<i>Per cent</i>	
-0.135	-0.055	0.080	1,178	100	
-0.120	-0.050	.070	1,102	95	Only heavy grains left.
-0.100	-0.045	.055	978	48	
-0.090	-0.040	.050	932	6	
-0.075	-0.035	.040	834	3	Only very light grains lifted.
-0.070	-0.032	.038	812	1	
-0.058	-0.025	.033	757	0	

Air data.—Dry bulb, 94° F.; wet bulb, 77° F.; barometric pressure, 29.25 inches of mercury; vapor pressure (*e*), 0.732.

Sample calculation of air velocity.— $V=1096.5\sqrt{\frac{h}{w}}$

$$h=0.080$$

$$w=1.3245 \times \frac{(B-0.378e)}{459+t} = 1.3245 \times \frac{29.25-(0.378 \times 0.732)}{459+74} = 0.06932.$$

$$V=1096.5\sqrt{\frac{0.080}{0.06932}}=1178.$$

TABLE 4.—Air velocity for lifting corn

Static head	Total head	Velocity head	Velocity	Grain lifted
<i>In. water</i>	<i>In. water</i>	<i>In. water</i>	<i>Ft. per min.</i>	<i>Per cent</i>
-0.485	-0.190	0.295	2,262	100
-0.420	-0.175	.245	2,062	98
-0.350	-0.140	.210	1,908	92
-0.285	-0.125	.160	1,665	62
-0.245	-0.115	.130	1,503	25
-0.215	-0.100	.115	1,412	5
-0.195	-0.095	.100	1,317	2
-0.170	-0.090	.080	1,178	0

Air data.—Dry bulb, 94° F.; wet bulb, 74° F.; barometric pressure, 29.5 inches of mercury; calculated air weight, 0.06944 pound per cubic foot.

TABLE 5.—Air velocity for lifting wheat

Static head	Total head	Velocity head	Velocity	Grain lifted
<i>In. water</i>	<i>In. water</i>	<i>In. water</i>	<i>Ft. per min.</i>	<i>Per cent</i>
-0.230	-0.095	0.135	1,532	100
-0.205	-0.085	.120	1,443	90
-0.175	-0.075	.100	1,318	16
-0.145	-0.065	.080	1,178	4
-0.130	-0.055	.075	1,142	1
-0.120	-0.052	.068	1,087	0

Air data.—Dry bulb, 94° F.; wet bulb, 78° F.; barometric pressure, 29.25 inches of mercury; calculated air weight, 0.06928 pound per cubic foot.

In calculating the air velocity, the pitot-tube formula, $V = 1096.5 \sqrt{\frac{h}{w}}$, was used, where V is air velocity in feet per minute, h is the velocity head in inches of water pressure, obtained by subtracting the static head from the total head, and w is the weight of air mixture in pounds per cubic foot.

The weight of the air mixture was determined by a formula furnished by the Weather Bureau, of the United States Department of Agriculture, $w = 1.3245 \times \frac{(B - 0.378e)}{459 + t}$, where w is the weight or density of the air mixture in pounds per cubic foot, B is barometric pressure in inches of mercury, e is vapor pressure,⁴ and t is temperature of air in degrees Fahrenheit.

Curves showing the relation between the air velocity in feet per minute and the percentage of the grain lifted from the screen (fig. 31)

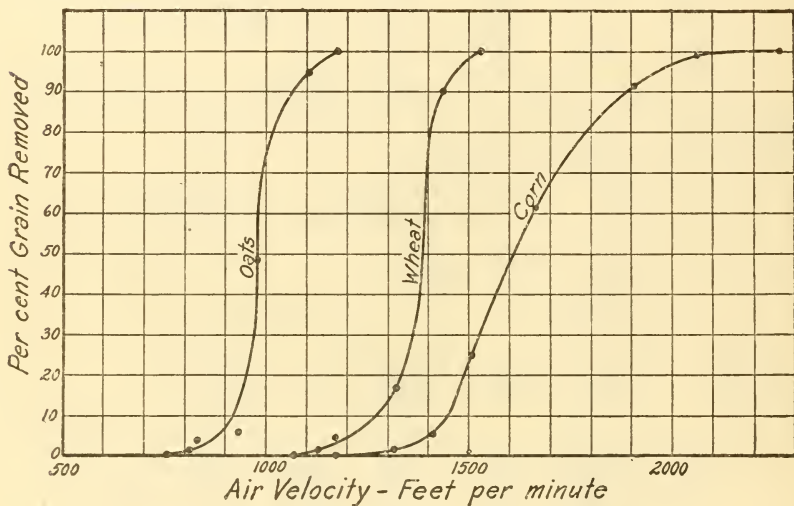

FIG. 31.—Percentage of grain removed at various air velocities

indicate that there is a difference of several hundred feet per minute between the velocities at which the light and heavy kernels of the different grains are carried by the air currents. The data may therefore be of use in designing grain-cleaning equipment. The big variation between the high and low velocities for corn is due to the different sizes and shapes of the kernels. Large, flat grains were picked up at a lower velocity than the medium-sized kernels. The maximum velocity at which corn and wheat were not lifted is very nearly the same, but the velocities at which all the kernels of these two grains were lifted differ greatly. This difference is due to the slight variation in the size and shape of wheat kernels as compared with the large variation in corn.

⁴ These values are taken from Psychrometric Tables for Obtaining the Vapor Pressure, Relative Humidity, and Temperature of the Dew-Point, by C. F. Marvin, U. S. Department of Agriculture, Weather Bureau Bulletin 235 (1910).

The velocity at which oats are not lifted, 757 feet per minute, is of the greatest value in proportioning a dust-collecting hood. Oats is the lightest grain handled in an elevator, and the maximum velocity at which it is not lifted is the determining value in proportioning a hood which will not lift grain.

Experiments had shown that the air velocity at the opening of a satisfactory hood should never exceed 757 feet per minute. Observation had shown that the most satisfactory air velocity for the main pipe lines and branches is about 4,000 feet per minute. The velocity in some of the branches near the fan, however, is often much higher because of the high static pressure in the main pipe. For that reason it was considered that a hood of standard dimensions for general use in grain elevators should be of such proportions that, with an air velocity of approximately 6,000 feet per minute in the pipe line, an air velocity of more than 757 feet per minute can not exist at the hood intake. A hood with an intake area nine times the area of the pipe connection was considered adequate for this purpose; but tests made with such a hood showed that, because of small eddies at the opening, light grains were picked up from a screen inserted in the mouth of the hood when a velocity of only 4,000 feet per minute was maintained at the pipe connection. Further experiments showed that a hood having an intake area equal to 12 times the area of the pipe connection would not pick up the lightest grains placed on a screen and inserted directly in the mouth of the hood at velocities up to 7,275 feet per minute. The intake of the United States Department of Agriculture hood, therefore, has an area equal to 12 times the area of the pipe connection.

The dimensions of the United States Department of Agriculture hood (fig. 32) were calculated in terms of the pipe diameter and some other required dimension of the hood. In establishing dimensions for the length and width of the intake for piping of various diameters, so that the area of the intake is always 12 times the area of the pipe connection, algebraic expressions were used. With D the diameter of the pipe connection, L the length of the rectangular hood opening, and W the width of the rectangular hood opening, then,

$$WL = 12 \frac{\pi D^2}{4}, = 9.425 D^2, \text{ or approximately } L = \frac{9.5 D^2}{W}, \text{ and } W = \frac{9.5 D^2}{L}.$$

The height of the hood was determined in terms of the length of the rectangular opening. Consequently the flare of the hood is a definite angle for openings of all sizes and shapes. The most satisfactory height is one and one-fourth times the length of the hood opening, $H = 1\frac{1}{4}L$, measured from the apex of the extended cone to the mouth of the hood. The angle made by the sides of the hood with the horizontal is an angle whose tangent is 2.5, or an angle of $68^\circ 12'$. Experiments have shown that within reasonable limits a uniform flow of air enters the mouth of a hood having these proportions.

Dimensions for pipe connections of different diameters and for hood openings of various sizes are given in Table 6. When one or two dimensions of the hood are known, the others can easily be calculated. For instance, let it be assumed that a hood with a mouth 30 inches long and a pipe connection as small as is satisfactory is desired for use over a conveyor belt. The length, 30 inches, is given

in the first column in the table. Reading across, the height of the hood (*H*) is 37½ inches to the apex of the cone, and the width (*W*) is 11½ inches for a 6-inch pipe connection. If a larger pipe connection is desired, the width of the hood only need be changed to care for the extra volume of air at a permissible velocity.

TABLE 6.—Dimensions of United States Department of Agriculture hood (fig. 32)

Length of opening (L)	Height (H)	Width (W)							
		Diameter of pipe connection (D)							
		3-inch pipe	4-inch pipe	5-inch pipe	6-inch pipe	7-inch pipe	8-inch pipe	9-inch pipe	10-inch pipe
	<i>Inches</i>	<i>Inches</i>	<i>Inches</i>	<i>Inches</i>	<i>Inches</i>	<i>Inches</i>	<i>Inches</i>	<i>Inches</i>	<i>Inches</i>
10 inches	12½	8½							
11 inches	13¾	7¾							
12 inches	15	7¼							
13 inches	16¼	6¾							
14 inches	17½	6¼	11¾						
15 inches	18¾	5¾	10½						
16 inches	20	5½	9½	15					
17 inches	21¼	5	9	14					
18 inches	22½	4¾	8½	13¼					
19 inches	23¾	4½	8	12½	18				
20 inches	25	7¾	12	17¼					
21 inches	26¼	7¼	11½	16½					
22 inches	27½	7	11	15½	21¼				
23 inches	28¾	6¾	10½	15	20¼				
24 inches	30	6½	10	14¼	19½				
25 inches	31¼	6¼	9½	13¾	18¾	24½			
26 inches	32½		9¼	13¼	18	23½			
27 inches	33¾		9	12¾	17¼	22½			
28 inches	35		8½	12¼	16¾	21¾	27½		
29 inches	36¼		8¼	12	16	21	26½		
30 inches	37½		8	11½	15½	20½	25¾		
31 inches	38¾		7¾	11	15	19¾	25	30¾	
32 inches	40			10¾	14½	19	24¼	29¾	
33 inches	41¼			10½	14¼	18½	23½	28¾	
34 inches	42½			10¼	13¾	18	22¾	28	
35 inches	43¾			9¾	13½	17½	22	27¼	
36 inches	45			9½	13	17	21½	26½	
37 inches	46¼			9¼	12¾	16½	21	25¾	
38 inches	47½				12¼	16	20¾	25	
39 inches	48¾				12	15¾	19¾	24½	
40 inches	50				11¾	15¼	19¼	23¾	
41 inches	51¼				11½	15	19	23¼	
42 inches	52½				11¼	14½	18½	22¾	
43 inches	53¾				11	14¼	18	22¼	
44 inches	55					10¾	17½	21¾	
45 inches	56¼					13½	17¼	21¼	
46 inches	57½					13¼	16¾	20¾	
47 inches	58¾					13	16½	20¼	
48 inches	60					12¾	16	20	
49 inches	61¼					12½	15¾	19½	
50 inches	62½					12¼	15½	19	
51 inches	63¾						15¼	18¾	
52 inches	65						15	18¼	
53 inches	66¼						14¾	18	
54 inches	67½						14¼	17¾	
55 inches	68¾						14	17¼	
56 inches	70						13¾	17	
57 inches	71¼							16¾	
58 inches	72½							16½	
59 inches	73¾							16¼	
60 inches	75							16	

At a velocity of 7,275 feet per minute, the maximum which could be obtained with the United States Department of Agriculture hood in a 7-inch pipe, with the fan equipment shown in Figure 30, fine wheat scourings on a tray were just moved by small eddies when the tray was 12 inches from the face of the hood, and wheat and oat chaff were just picked up from a screen 4½ inches from the face of

the hood. No grain was lifted from the screen when it was placed directly in the hood intake.

At a velocity of 4,975 feet per minute, fine wheat scourings on a tray 12 inches from the hood intake were but slightly disturbed, chaff was picked up from a screen 4 inches from the intake, and the very lightest chaff was picked up from mixed grains and dockage on a screen placed in the mouth of the hood.

At a velocity of 4,000 feet per minute, the air currents were barely able, even with eddies, to move the fine wheat scourings on a tray 12 inches from the face of the hood. Light chaff was picked from a screen $3\frac{1}{2}$ inches from the intake. Only the very lightest chaff and wheat scourings were picked from a screen covered with grains and dockage placed in the mouth of the hood. Grains of oats were not even disturbed on a screen placed in the mouth of the hood.

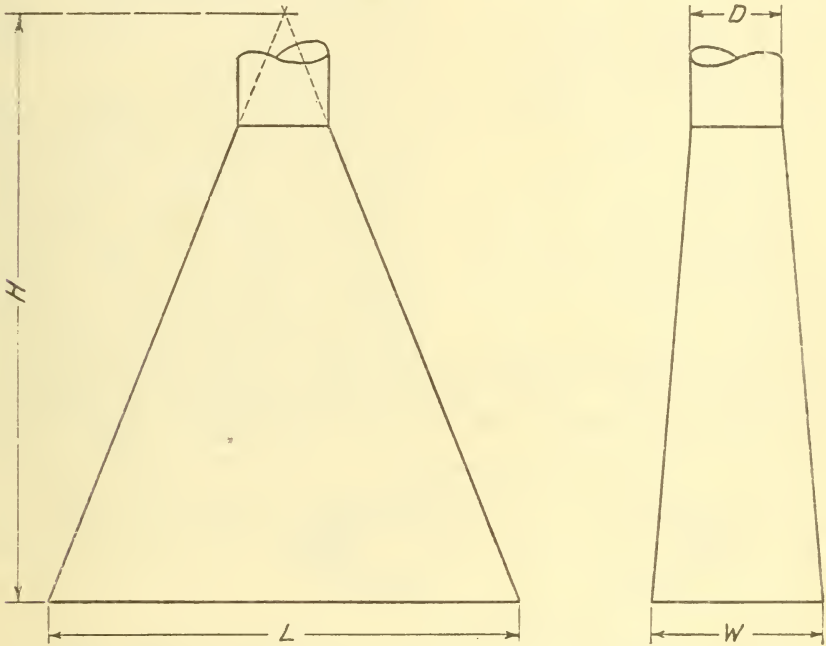

Fig. 32.—United States Department of Agriculture hood. Dimensions are given in Table 6

The intake of the United States Department of Agriculture hood should be from 12 to 18 inches from the grain stream, never closer than 12 inches. When the hood is placed in a horizontal position, the distance between the bottom of the hood and the grain should never be less than the width of the hood. The hood should never be installed at a point where grain can be thrown into it. In all cases it should be placed as close as possible to the point of dust dissemination, within 12 to 18 inches from the grain stream.

Sometimes the space available may not be large enough for a hood of the required proportions. In placing a hood over an extremely wide belt or piece of equipment which requires a long hood opening, the hood must be extremely high in order to function satisfactorily over the entire length of the opening. To apply suction over a wide space, it is well to use two or more hoods fed by branches and

elbows from a common supply branch line (fig. 33). In an installation of this nature, very little overhead space is required to maintain a constant air velocity over the entire area of the hood opening. For a hood opening 42 inches long a single hood would be 42½ inches

high to an 8-inch pipe connection; twin hoods are only 18¾ inches to a 6-inch pipe connection, a reduction in height of 23¾ inches.

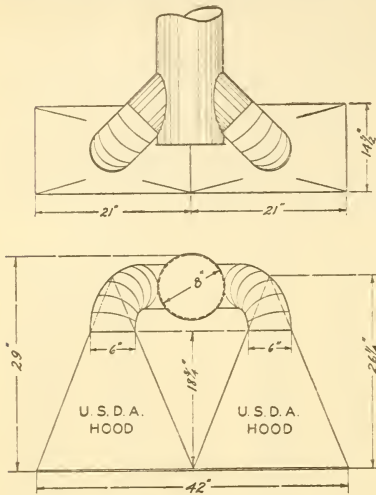

Fig. 33.—Hood suggested for use over a 42-inch belt

INSPECTION TRAPS

Properly designed traps in the branch lines serving dust-collecting hoods place the application of suction under the supervision and control of an inspector, thus removing the suspicions usually encountered in applying suction.

The design of an inspection trap is similar to that of the large grain trap used in the main trunk lines of floor-sweep systems. The cross-sectional area of the expansion chamber should be at least 12 times as great as the area of the branch pipe in order to insure a velocity sufficiently low to permit the heavier

material to fall to the bottom of the trap. The inspection trap, however, does not have a continuous discharge as in the case of the floor-sweep grain trap. The material separated remains on the bottom of the trap to indicate to the inspector the nature of the products

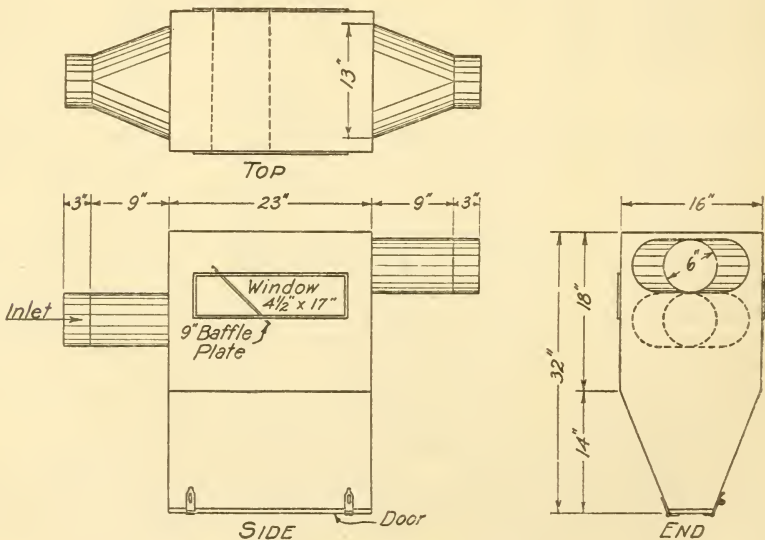

Fig. 34.—Inspection trap designed by the Underwriters Laboratories

gathered up by the suction. Access to the interior of the trap is provided by a door, which can be opened only by the inspector.

A trap designed and used successfully by the Underwriters Laboratories (fig. 34) is usually installed in a horizontal run of the branch pipe to the hood. A baffle assists in making the separation. A trap of simple construction developed by the Bureau of Chemistry (fig. 35) can be installed instead of an elbow connecting horizontal and vertical runs of piping, or it may be placed in a vertical run of piping by the use of another elbow.

AIR-VELOCITY CONTROL VALVES

Valves are necessary for controlling the air velocity in many of the branch pipes of a dust-collecting system, especially near the fan where the static pressure in the main pipe is very high. Valves make it possible for a dust-collecting system to be so balanced that the velocity in all the branches will be uniform. They reduce the power consumption, because less air is handled by the system and a lower static pressure at the fan is required. Of equal importance is the fact that proper valves, placed in the branches, make it possible to control the air velocity in a branch pipe connected to the hood. Such valves should be so designed that they can be locked in position by the inspector who has supervision over the grain weights.

A valve of the blast-gate type (fig. 36) has been used successfully. In one elevator the installation of these gates in the branches made

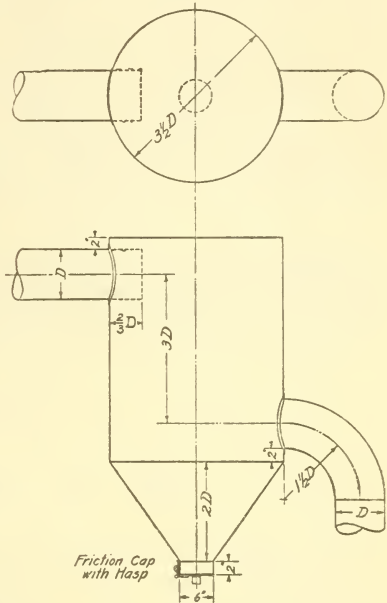

FIG. 35.—United States Department of Agriculture inspection trap

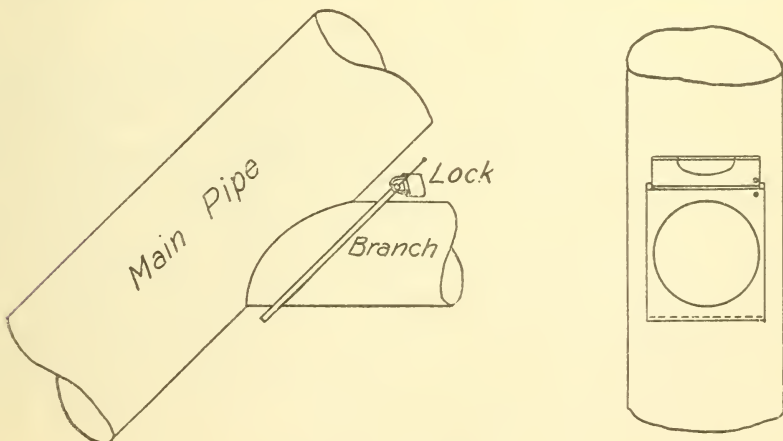

FIG. 36.—Blast gate

the dust-collecting and floor-sweep systems operate satisfactorily; before the valves were installed, the distant floor-sweep hoods did not have enough suction to pick up grain. The gates are placed in the branches as close as possible and parallel to the main pipe. The amount of suction and consequently the amount of air to be handled by the branch line is regulated by the opening of the slide, which fits tight into a groove and remains in any position it is set. By sealing or locking the slide in the desired position an inspector can control the suction and air velocity in a branch supplying a hood.

Another method of controlling the velocity in the branches is by means of a butterfly valve (fig. 37) inserted in the branch, preferably as near as possible to the main pipe. This valve, designated the United States Department of Agriculture velocity control valve, may be locked in the desired position.

EFFECT ON GRAIN WEIGHTS

Observations have been made in various elevators throughout the country to determine what effect the use of suction as applied by modern dust-collecting equipment has on grain weights.

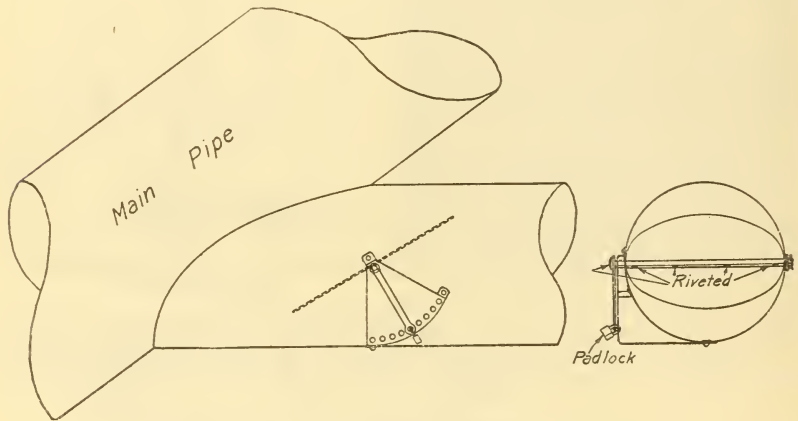

FIG. 37.—United States Department of Agriculture velocity control valve

Tests were conducted by the Bureau of Chemistry in an export elevator equipped with a dust-collecting system that applied suction to the scale hoppers, garners, belt loaders, and boots. One of the scale hoppers was filled with No. 2 hard wheat and weighed. The grain was then dumped and spouted into a storage bin, from which it was later transferred to a shipping belt to be elevated for reweighing. Four runs were made, two with suction and two without suction. The garner bin was swept clean before each weighing, and the first weight of each run was taken under the same conditions as the last weight of the preceding run. Four suction lines not connected to hoods acted directly on the grain: A 3-inch pipe connection at the belt loader, a 3-inch pipe at the elevator boot, a 6-inch line to the garner bin, and a 6-inch connection to the scale hopper. The results of these tests are shown in Table 7.

The shrinkage losses varied whether suction was used or not. On the whole, the shrinkage loss was slightly greater when the fans

were not operating than when they were running. In tests Nos. 1 and 4, when the fans were operating, the total shrinkage loss was 140 pounds for a total weight of 232,600 pounds; in tests Nos. 2 and 3, when the fans were not operating, the loss was 180 pounds in a total weight of 232,700 pounds. The largest shrinkage loss occurred in test No. 2 when the fans were not running. The losses in all cases were low. The results indicate that the effect on grain weights when suction is applied is practically the same as in the normal handling of grain without dust-collecting equipment.

Preliminary investigations were conducted by the Bureau of Chemistry in 1918 in a number of terminal elevators to determine the quantity of dust collected while elevating carlots of grain. The results of tests on 39 cars showed an average of $7\frac{1}{2}$ pounds of dust collected per car. Several cars in this lot contained very dusty oats and several others contained screenings. An average of 19 pounds of dust per car was removed from four cars of No. 3 white oats. In spite of the fact that these tests were made with 1918 equipment, which was not so designed that at all fan speeds it would be impossible to lift heavy particles from the moving grain stream, the quantity of dust gathered by the dust-collecting system probably would not exceed the natural loss incurred without dust-collecting equipment.

TABLE 7.—*Shrinkage when grain is handled with and without suction*

Test No.	First weight	Second weight	Difference in weight	Difference per 1,000 bushels	Shrinkage	Remarks
	<i>Pounds</i>	<i>Pounds</i>	<i>Pounds</i>	<i>Pounds</i>	<i>Per cent</i>	
1.....	116, 440	116, 380	60	30.9	0.052	Fans on.
2.....	116, 420	116, 280	140	72.3	.120	Fans off.
3.....	116, 280	116, 240	40	21.3	.034	Do.
4.....	116, 160	116, 080	80	41.6	.069	Fans on.

Recent tests conducted by the supervisor of the Minnesota Railroad and Warehouse Commission in an elevator equipped with a dust-collecting system, designed and installed so that only the light floating dust is removed, showed the following results:⁵

During the unloading of a car containing 50,000 pounds of flax screenings, $13\frac{1}{2}$ pounds of dirt, refuse, and fibrous material was collected. In the unloading of another car containing 50,000 pounds of No. 2 northern wheat, only $25\frac{1}{2}$ ounces of dust was collected. These two tests were conducted on the extreme grades of material generally handled in a terminal grain elevator.

The quantity of dust removed by a dust-collecting system depends upon the design and upon the control of the air currents. If proper care is taken in installing the equipment, no more dust will be exhausted from the plant by a dust-control system than naturally settles when no dust-control measures are applied. In the one case the explosion hazard is greatly reduced with the removal of the dust to the outside of the plant; in the other case the explosion hazard is increased, with the gradual accumulation of dust within the plant.

⁵ "The Removal of Floating Dust in Grain Elevators," a report prepared by the Underwriters Laboratories and published by The National Safety Council, 1924, p. 31-32.

CONCLUSIONS

Dust collection in grain elevators may not prevent explosions, but it will keep a small dust ignition from developing into a disastrous explosion. As a result of experiments with special laboratory equipment, the Bureau of Chemistry has designed new dust-handling equipment, which should meet all objections to the installation of such systems on the ground that they affect the weight of the grain. Recommendations for the installation of the improved dust-collecting equipment are based on a survey of some of the principal grain elevators of the United States, which indicated that it would be possible to adapt the new equipment to the larger grain-handling plants of all types.

ADDITIONAL COPIES

OF THIS PUBLICATION MAY BE PROCURED FROM
THE SUPERINTENDENT OF DOCUMENTS
U. S. GOVERNMENT PRINTING OFFICE
WASHINGTON, D. C.

AT
15 CENTS PER COPY



**ORGANIZATION OF THE
UNITED STATES DEPARTMENT OF AGRICULTURE**

March 10, 1928

<i>Secretary of Agriculture</i>	W. M. JARDINE.
<i>Assistant Secretary</i>	R. W. DUNLAP.
<i>Director of Scientific Work</i>	A. F. WOODS.
<i>Director of Regulatory Work</i>	WALTER G. CAMPBELL.
<i>Director of Extension</i>	C. W. WARBURTON.
<i>Director of Personnel and Business Administration</i>	W. W. STOCKBERGER.
<i>Director of Information</i>	NELSON ANTRIM CRAWFORD.
<i>Solicitor</i>	R. W. WILLIAMS.
<i>Weather Bureau</i>	CHARLES F. MARVIN, <i>Chief</i> .
<i>Bureau of Animal Industry</i>	JOHN R. MOHLER, <i>Chief</i> .
<i>Bureau of Dairy Industry</i>	L. A. ROGERS, <i>Acting Chief</i> .
<i>Bureau of Plant Industry</i>	WILLIAM A. TAYLOR, <i>Chief</i> .
<i>Forest Service</i>	W. B. GREELEY, <i>Chief</i> .
<i>Bureau of Chemistry and Soils</i>	H. G. KNIGHT, <i>Chief</i> .
<i>Bureau of Entomology</i>	C. L. MARLATT, <i>Chief</i> .
<i>Bureau of Biological Survey</i>	PAUL G. REDINGTON, <i>Chief</i> .
<i>Bureau of Public Roads</i>	THOMAS H. MACDONALD, <i>Chief</i> .
<i>Bureau of Agricultural Economics</i>	LLOYD S. TENNY, <i>Chief</i> .
<i>Bureau of Home Economics</i>	LOUISE STANLEY, <i>Chief</i> .
<i>Federal Horticultural Board</i>	C. L. MARLATT, <i>Chairman</i> .
<i>Grain Futures Administration</i>	J. W. T. DUVEL, <i>Chief</i> .
<i>Food, Drug, and Insecticide Administration</i>	WALTER G. CAMPBELL, <i>Director of Regulatory Work, in Charge</i> .
<i>Office of Experiment Stations</i>	E. W. ALLEN, <i>Chief</i> .
<i>Office of Cooperative Extension Work</i>	C. B. SMITH, <i>Chief</i> .
<i>Library</i>	CLARIBEL R. BARNETT, <i>Librarian</i> .

This bulletin is a contribution from

<i>Bureau of Chemistry and Soils</i>	H. G. KNIGHT, <i>Chief</i> .
<i>Chemical and Technical Research</i>	C. A. BROWNE, <i>Chief</i> .
<i>Chemical Engineering Division</i>	DAVID J. PRICE, <i>Engineer in Charge</i> .

