





Railway Mechanical Engineer

Established 1832

2151

INDEX TO VOLUME XCII
1918

9r625.05

R1574

v. 32

INDEX, 1918

VOLUME XCII

A			
Acme Machine Tool Co., Cincinnati Acme flat turret lathe	633*	Baldwin, G. E., Automatic hard grease cup	288*
Acme Machine Tool Co., Universal flat turret lathe	363*	Balwin & Ohio, Front deck brace	281*
Administration, Railroad (see Railroad Administration)		Barco Mfg. Co., All-metal steam heat connection for cars	176*
Air Brake Association convention proceedings	315*	Barnett Foundry & Machine Co., New idea vice	476*
Air brakes (see Brakes, air)		Beams, The design of offset, by Victor M. Summa	514*
Air compressor, An unusual	582†	Benjamin, C. H., Industrial fellowships	302†
Air compressor lubricating cup, E. F. Glass	477*	Benjamin, C. H., Maintain industrial fellowships	18
Air compressor oiling step	160*	Berter, Capt. O. S., Jr., Intensive locomotive development	131*
Air compressor rating, Definitions of terms used in	164*	Bickett Machine & Mfg. Co., Horizontal bench miller	289*
Air compressor table, by J. H. Hahn	159*	Bill, The poor little rich, by Gladys Schuster	320
Air compressors, Maintenance of cross-compound	471	Blizzards, Are you prepared for?	511‡
Air compressors, Reclaiming top heads of Westinghouse 9½-in., by J. H. Hahn	571*	Blowers, Railway shop fans and, by J. I. Wickman	166
Air hammer attachment for spitting nuts, by J. S. Breyer	519*	Bohan, W. J., The need of a business box car	153
Air pump piston rings, Special tool for turning up, C. B. & O.	170*	Boiler design and combustion	76†
Air pumps, Air valve lift gage for Westinghouse	231*	Boiler, Don't neglect the, by E. W. Young	35
Air pumps, Effect of bushing the high pressure cylinder of 8½-in. cross-compound, by R. M. Durnford	280	Boiler explosion, An unusual	396*
Air, Save fuel by saving	512	Boiler repairs, Electric welding reduces	36
Aishton, R. H., Railroads and their relation to the fuel problem (convention)	354	Boiler scale and water treatment, by George Austin	161*
Amalgamation train for American wounded, British	397*	Boiler scale, Motive power efficiency and	73‡
Ambulance trains for the U. S. army	266†	Boiler shop equipment, Some interesting, by F. W. Severt	167*
American Flexible Bolt Co., Rivets	582*	Boiler stresses, Calculation of, by G. E. Parks	139*
American Tool Works Co., 36-in. high duty lathe	362*	Boiler tools, New designs of, William Kerr	117*
Anderson, J. A., Valve gear	424*	Boilers: Don't reduce washout time too much, by C. E. Brooks	490†
Anthony, J. T., Radiant heat and firebox design	658*	Boilers, Keep from needing repairs, by George Austin	35*
Apprentice training during the war	378‡	Boilers, leaky, Indiscriminate use of the injector causes, by George Austin	284
Apprentices, "Don'ts" for, by Henry Gardner	286	Bolsters, Effect of holes in the sides of box, by L. E. Endsley	507*
Apprenticeship, Improved, methods on the Pennsylvania, by J. H. Yoder	8*	Bolsters, Freight car and tender truck, by G. S. Chiles and R. G. Kelley	211*
Apprenticeship, Practical results from modern, by H. S. Rauch	20	Bolsters, Local stresses in box, by L. E. Endsley	343*
Apprenticeship, Ted Symington—no slacker, by A. J. T. Cate	679	Bolt manufacture in railroad shops, by M. H. Williams	465*
Are Welding Machine Co., Inc., Welding tool with positive electrode clamp	685*	Bonds, Selling, to ready buyers	183‡
Armstrong, Allen, Firing up locomotives	29	Books	
Armstrong, George W., Expedite locomotive repairs	341*	American Railway Tool Foremen's Association 1917 year book, by R. D. Fletcher, secretary and treasurer	380
Ash pan opening, Ample	74‡	Catorific value of fuel, The, by Herman Poole	489
Ash pans in France, Polishing	166*	Comparative tests of six sizes of Illinois coal on a Mikado locomotive, by Edmund C. Rothbart et al.	380
Ashton, Topoka & Santa Fe, 2-8-2 type locomotive	83*	Cost of power, The, by G. B. Gould and Carlton W. Hubbard	435
Ashton, Topoka & Santa Fe 4-8-2 type locomotives	649*	Economical use of fuel in locomotives, University of Illinois	643
Ashton, Topoka & Santa Fe, Machines for milling piston rod keyways	37*	Eye hazards in industrial occupations, by Gordon L. Berry	591
Ashton, Topoka & Santa Fe, Reclamation of axle	451*	Finding and stopping waste in modern rooms	380
Ashton, Topoka & Santa Fe, Standard flue bending tools	217*	Fuel economy in the operation of hand fired power plants, University of Illinois	435
Austin, George, Boiler scale and water treatment	161*	Government Association of Illinois	541
Austin, George, Firebox repairs	217*	Lubricating engineers' handbook, by John Rome Battle	489
Austin, George, Indiscriminate use of the injector causes boilers to leak	284	Modern locomotive valves and valve gears, by C. L. McShane	591
Austin, George, Keep boilers from needing repairs	35*	Proceedings of the Air Brake Association	489
Automatic straight air brake, Road tests of the	453*	Proceedings of the International Railway Fuel Association	75
Axle, Heat treatment of, by Dwight D. Miller	419*	Proceedings of the International Railway General Foremen's Association	435
Axles, Reclamation of car	451*	Shop expense analysis and control, by Nicholas Thiel Yecker	130
Ayers, A. R., Organization maintenance	210	Boring bar cutters, Prolonging the life of, by Charles Trimby	282*
		Boring mill (see Machine tools)	
		Boring tool, Expansion, Davis Boring Tool Co.	66*
		Boring tool holder, Ready Tool Co.	362*
		Borings and turnings, Sale of, by Southern Pacific	216†
		Boston & Maine, A new coal sprinkler arrangement	216*
		Boston & Maine, Billerica reclamation plant	671*
		Boutell, Hugh C., The proper location of locomotive cab fittings	606
		Boyle, O. D., Why don't daddy come home?	517
		Brake, Air, conditions demand attention	377‡
		Brake, air, inspectors, Co-operation of traveling engineers and, Traveling Engineers' Convention	553
		Brakes, Air, maintenance of	568
		Brakes: Air, piston travel and braking power, by H. F. Wood	662
		Brakes, air, Preparing, at terminals (Air Brake convention)	318
		Brake band hanger, A. & Z (L. E. Atwell and C. A. Zwebel)	175*
		Brake beams, Limiting outline for U. S. standard	208*
		Brake hose, The safe life of an air (Air Brake convention)	317
		Brake maintenance, Air, M. C. B., circular on	669
		Brake maintenance, Freight, by F. B. Farmer	406
		Brake maintenance, Improve air	641‡
		Brake pipe leakage	508
		Brake, Road tests of the A. S. A.	453*
		Brake test, Standard	677
		Breyer, J. S., Air hammer attachment	519*
		Britt, Thomas, Suggestions for saving coal (Fuel convention)	354
		Brooks & Co., Inc., E. J., A self-cleaning car seal	532*
		Brooks, C. E., Don't reduce washout time too much	490†
		Brooks & Co., Inc., Making cold chisels	171*
		Brush, Rotary, used for car cleaning, Illinois Central	460*
		Buell, D. C., Selection and training of women workers	23
		Buffalo, Rochester & Pittsburgh, Coal gate holders	450*
		Buffalo, Rochester & Pittsburgh, Shop scheduling on	219*
		Bullard Machine Tool Co., 61-in. Maxi Mill	358*
		C	
		Cain, Paul H., Manufacturing scrap iron into locomotive parts	576*
		Canadian Pacific, Jig for machining nuts	524*
		Campfield, L. T., Draft gears should be maintained	565*
		Carbocool—a new fuel	175
		Carbon monoxide, When, is fatal	426†
		Carolina, Chinchfield & Ohio, Time saved by paint spraying machines	572
		Carter, W. S., The railway industrial army	314
		Car	
		Axles (see Axles)	
		Bad order situation	614
		Betterment work, Keep up	434‡
		Box doors need attention	540‡
		Box, The need of a business, by W. J. Bohan	153
		Building steel passenger, A decade of progress in	334
		Cleaning, Cutting the cost of passenger	460*
		Cleaning, Passenger, by F. Eley	668
		Coal, Limitations to the capacity of, in Condition, Improve the	148
		Deliveries, Standard	656
		Department, Efficiency in the, by W. K. Wilcox	461
		Department of the C. M. & St. P.	615*
		Department orders	620
		Design, Tabular method of calculating moment of inertia, by Wendell Meyer	261
		Drop door latch and lock, N. & W. 100-ton lot	96*
		Ends, Standard reinforcing of house	590‡
		Gun transport, for the Navy	457*
		Hitters, Adapting Baker, to burn soft coal, C. M. & St. P.	661*
		Hopper door operating and locking device, National Railway Appliance Co.	613*
		Interchange: Should a run, repair or transfer rule be adopted	184‡

*Illustrated article; †editorial; ‡short non-illustrated article or note; †communication.

G

Gage, Air valve lift, for locomotive air pumps, Westinghouse, 231*
 Gage, Injector, by E. F. Glass, 410*
 Gages, Ashton master pilot, 120*
 Gardner, Henry, "Don'ts" for apprentices, 286
 Garter, Save the rubber, by J. Rutland, 490*
 General Electric Co., Pressure governor for gas and liquid systems, 477*
 Georgia Railroad, Spring banding machine, 163*
 Germany, Railway construction, 434\$
 Gibbons, J. W., Intelligent buying and intelligent supervision of painting, 40
 Gillilan Bros. Smelting & Refining Co., Portable electric rubber, 232*
 Glass, E. F., Injector gage, 410*
 Glass, E. F., Lubricating cup, 477*
 Goggles with non-breakable lenses, Strauss & Buegeleisen, 120*
 Gold Car Heating & Lighting Co., Inside connected vapor valve, 634*
 Gold Car Heating & Lighting Co., Steam heat end valve with automatic drip, 581*
 Goodwin, E. G., Steel frame refrigerator cars, N. & W., 401*
 Government control, Car retaining order, 127\$
 Governor for gas and liquid systems, Pressure, General Electric Co., 477*
 Grant, James, Wedge block for jacking locomotives, 680*
 Grease, Substitutes for, 495\$
 Greenough, Grafton, Standardization of locomotives (see Machine tools), 248
 Grinder, Portable, Electric, Holpost, Gillilan Bros. Smelting & Refining Co., 232*
 Grinding in locomotive shops, by M. H. Williams, 629*
 Grinding of car wheels, The, 242\$
 Grinding wheels, Glass shields for, N. W., 115*
 Grinding wheels, Soft, by Howard W. Dunbar, 678

H

Hahn, J. H., Air compressor table, 159*
 Hahn, J. H., Gages for driving box table, 164*
 Hahn, J. H., Reclaiming top heads of Westinghouse 9½-in. air pumps, 571*
 Halsey, W. H., Tipping carbon steel tools, Hammer attachment, United Hammer Co., 288*
 Harris Engineering Co., H. E., Angle and lead testing machine for thread gages, 290*
 Harrison, F. J., Method of supervising running repairs, 424*
 Harrison, F. J., Shop scheduling increases output, 33
 Heat in steel treating, Principles of the generation and application of, by A. F. MacFarland, 164
 Heat treatment of axles, by Dwight D. Miller, 419*
 Heaters, Adapting Baker to burn soft coal, by A. Kressin, 661*
 Henderson Electric Co., A portable vise and bench, 17\$
 Henry, J. V., Babbitt separator, 422*
 Henry, J. V., Car wheel drop pit, 356*
 Hofstot, Henry P., Development of the steel car, 147
 Hoist, Enginehouse trolley, 376*
 Honeycomb, 159
 Hose devices, Two valuable, N. Y. C. & St. L., 222*
 Hose mounting and clamping machines, Westinghouse Air Brake Co., 683*
 Hose, Steam heat; Barco all-metal substitute, 176*
 Hose, The safe life of an air brake (Air Brake convention), 617
 Hours of locomotive and repair forces, Working, 656
 Hours, Uniformity of, demands of labor, 300\$
 Huyett, K. B., Cutting tool lubrication, 282
 Hydraulic Press Mfg. Co., Hydraulic bending press, 365*
 Hydraulic ram, An improvised, by C. W. Schane, 682*

I

Illinois Central, Cutting the cost of exterior car cleaning, 460*
 Illinois Central, Something new in reamers, 169*
 Illinois coal tests, University of, 80\$
 Illumination promotes shop efficiency, Good India, Heavy freight cars for a narrow-gauge railway in, by F. C. Coleman, 569*
 Individual is the vital factor, The (engine-house work), by John C. Murdoch, 62*
 Ingersoll-Rand Co., Air drill for light work, 33
 Initiative, Encourage, by J. A. North, 170
 Insurance, Group, by A. J. Schneider, 170
 Interchange inspection, Railroad Administration circular No. 7, 393
 International Fuel Association (see Fuel Association).
 Interstate Commerce Commission safety inspector's report, 17

J

Jack, A new car, Duff Mfg. Co., 531*
 Jack Winzate, secure a raise, How, by Harvey DeWitt Wolcomb, 223
 Johnson, Alba B., Standardization of locomotives, 246
 Johnson, E. D., Welding firebox patches and cracks, 520*
 Johnson, J. O., Labor saving devices on the Southern, 221*
 Journal box packing situation, The, 582*
 Journal box packing situation, The, 567, 589\$, 592\$
 Journal box, System for preparing packing, Milwaukee Tap Works, 423*
 Journal boxes, Hot, on freight cars, by F. W. Schultz, 152

K

Kadel, B. W., 100-ton coal car for the Norfolk & Western, 93*
 Kelley, R. G., and G. S. Chiles, Freight car and tender truck bolsters, 270*
 Kerr, William, New designs of boiler tools, 117*
 Keyways, Device for making, for eccentric arms in crank pins, C. B. & O., 112*
 Koch & Sandige, Jiffy adjusting cutter, 479*
 Kressin, A., Adapting Baker heaters to burn soft coal, 661*

L

Labor compensation, A system of, by M. K. Smogorzewsky, 325*
 Labor, Conservation of, 378\$
 Labor in the paint shop, Conservation of, by J. H. Pitard, 39
 Labor, Railroad Administration Board of, 394
 Labor savers on French railways, Mechanical labor situation, The present, 392\$
 Labor, Uniformity of Hours, demands of, Laboratory, Railroads should make use of locomotive, by Edward C. Schmidt, 19
 Lake, Albert H., Jr., Helical spring calculation, 101*
 Lamert, Margaret, The field for women in railroad shop work, 25
 Lateral motion, 278
 Lathe (see Machine tools).
 Lee, J. H., for machining nuts, 524*
 Lehigh & Hudson, Cutting out side rod straps with oxy-acetylene outfits, 287*
 Lewis-Shepard Co., A high lift industrial Liberty Loan appeal, Fourth, 401
 Liberty Loan campaign, 100 per cent goal in railroad, 254*
 Liberty Loan, Organize the, 660
 Liberty Loan results, Fourth, 592\$
 Liberty Loan, Subscribe in 100 per cent amounts, 539\$
 Lignite, Briquettes of, in Canada, 632\$
 Lister, F. G., Main and side rods, 463*
 Loading of lumber, The improper, 15*

Locomotive

Ash pan (see Ash pan).
 Auxiliaries, The steam consumption of, 435\$
 Axles (see Axles).
 Boiler (see Boiler).
 Cab and cab fittings, 596
 Cab fittings, Proper location of, by Hugh G. Boutell, 606
 Coal sprinkler, A new arrangement, Boston & Maine, 216*
 Crank pin, Ball bearing, by B. P. Flory Crosshead (see Crosshead).
 Cylinder, weld, A difficult, by D. A. Donelson, 277*
 Cylinders, Low pressure, of the Virginian Mallet type locomotives, 603*
 Deck brace, Front, by Joseph Smith, 281
 Deliveries, Improving, 74\$
 Deliveries, Standard, 656
 Design, Dynamic augment problem, by E. W. Strong, 257*
 Development, Intentional, by Frank M. Beyer, Jr., 187
 Diagrams, clearance and weight, Standard, 607*
 Driving box (see Driving box).
 Exhaust tip, Annular ported, 445*
 Exports, 148\$
 Failures, Co-operate to reduce, by F. W. Taylor, 222
 Feedwater heating, 63*
 Feedwater heating, by H. S. Vincent, 645*
 Firebricks (see Firebricks).
 Front end spark arrester, I. A. Seiders Fulcrum brackets, Stresses in bolts in, by Victor M. Summa, 156*
 Handling at terminals, by Frank M. Beyer, 275*
 Maintenance, How can the traveling engineers aid in, by F. P. Roesch, Traveling Engineers' convention, 552
 Maintenance problems, 33
 Maintenance, Relation of, to fuel economy, by Frank McManamy (Fuel convention), 352

Locomotive—(Continued)

Miles, Daily, on English railways, 392\$
 Operating efficiency, increase, by Clement, 5*
 Orders in 1917, New, 58*
 Orders for Government, 292
 Orders for standard, 369
 Plots, Why retain long, 642\$
 Piston and rod, C. P. 2-10-2 type, 324*
 Repair shop, A well organized, N. Y. C. Repairs, Accuracy in, by M. H. Williams, 673*
 Repairs, Don't put emes out until they're right, 22
 Repairs, Expedite, 341*
 Repairs, Foreign, 343\$
 Running repairs, Extend, 22
 Running repairs, Method of supervising, by E. J. Harrison, 52*
 Runs, Doubling the length of, 241\$
 Side play, 278
 Side rods (see Rods).
 Situation, Standard, 243\$
 Situation throughout the world, 670\$
 Specialty orders, Railroad administration, 395, 481, 583
 Specifications, An economy clause in, Standardization, 246
 Steam pipes, Method of applying outside, Locomotive Appliance Co., 119*
 Superheater performance, Traveling Engineers' convention, 652*
 Superheater performance, Watch the high water man, 7
 Tank without underframe, N & W., 445*
 Tender trucks (see Trucks).
 Terminal time, Reducing, by T. T. Ryan, 114
 Terminal time saving, 110
 Tests of N. & W. Mallet, by H. W. Reynolds, 502*
 Tests, Union Pacific 2-10-2 type, 323*
 Tonnage rating charts, Standard, 607*
 Valve chest (see Valve chest).
 Valve gear, redesigner, 424*
 Washout time, Don't reduce, too much, by C. E. Brooks, 490\$

Locomotive Appliance Co., Method of applying outside steam pipes, 119*
 Locomotive, French, 228\$
 Locomotive Superheater Co., Forged superheater return bends, 581*
 Locomotive Superheater Co., Tools for superheater maintenance, 621*

Locomotives

0-6-0 U. S. R. A. standard, 593*
 0-8-0 switcher, First standard, 543\$
 2-8-0 type, French, 228\$
 2-8-2 type, A. T. & S. F., 83*
 2-8-2 type, U. S. standard light, 436*
 2-8-2 type, U. S. standard heavy, 491*
 2-10-2 type, Union Pacific, 323*
 4-8-2 type, A. T. & S. F., 649*
 4-8-2 type freight, New York Central, 77*
 2-8-8-2 type, N. & W., by H. W. Reynolds, 445*
 2-10-2 Virginia, 600*
 Condition of, Report on, 605
 Drafting modern, by H. W. Hodgdon, 439*
 Electric, built in South Namibia, 438\$
 Electric, Pennsylvania Railroad, 87*
 Firing up, by Allen Armer, 29
 French, Yankee's idea of, 249*
 Germany sells, 367\$
 Keep, on the road, by F. W. Taylor, 52
 Rules for the delivery and transfer, Railroad administration, 444
 Standard, Deliveries of, 559, 605
 Standard, Distribution of, the, to the railroads, 386
 Standard, 331*, 387*
 Standard, The government orders, 300\$
 Standard, The question of, 186\$
 Transfer of, 185\$
 Lovejoy Tool Co., Inc., Inserted cutter tools, 479*
 Lubricating cup, E. F. Glass, 410*
 Lubrication, Cutting tool, by R. E. Huyett, 282
 Lubricators, Device for removing gaskets from sight feed, 224*
 Lumber, The improper loading of, 15*

M

MacDonald, J. M., Spring stripping machine MacFarland, A. F., Principles of the generation and application of heat in steel treating, 164
 MacDonald, Hon. William, Director general of railroads (photograph), 2*
 McAdoe resins, Director general, 643\$
 McAdoe, Supply interests, write Mr., 145
 McAuliffe, Eugene, Individual effort toward fuel saving (Fuel convention), 355
 McAuliffe, Eugene, Railway fuel conservation, Traveling Engineers' convention, 550
 McLenahan, W. J., Piece work system, railway, 411*
 McManamy, Frank, Address at Traveling Engineers' convention, 548
 McManamy, Frank, Mechanical department supervision, 597

* Illustrated article; \$editorial; fshort non-illustrated article or note; †communication.

Persons-General

Table listing names and page numbers for the 'Persons-General' section, starting with Hammond, H. on page 428 and ending with Walters, S. on page 387.

Persons—Master Mechanics and Road Foremen of Engines

Table listing names and page numbers for 'Persons—Master Mechanics and Road Foremen of Engines', starting with Adams, J. on page 491 and ending with Walters, S. on page 387.

Persons—Master Mechanics and Road Foremen of Engines

Table listing names and page numbers for 'Persons—Master Mechanics and Road Foremen of Engines', starting with Adams, J. on page 491 and ending with Walters, S. on page 387.

Persons—Car Department

Table listing names and page numbers for the 'Persons—Car Department' section, starting with Adams, J. on page 491 and ending with Walters, S. on page 387.

Persons—Shop and Engine House

Table listing names and page numbers for the 'Persons—Shop and Engine House' section, starting with Adams, J. on page 491 and ending with Walters, S. on page 387.

Persons—Master Mechanics and Road Foremen of Engines

Table listing names and page numbers for 'Persons—Master Mechanics and Road Foremen of Engines', starting with Adams, J. on page 491 and ending with Walters, S. on page 387.

Persons—Master Mechanics and Road Foremen of Engines

Table listing names and page numbers for 'Persons—Master Mechanics and Road Foremen of Engines', starting with Adams, J. on page 491 and ending with Walters, S. on page 387.

Persons—Purchasing and Storekeeping

Table listing names and page numbers for the 'Persons—Purchasing and Storekeeping' section, starting with Adams, J. on page 491 and ending with Walters, S. on page 387.

Personals—Purchasing and Storekeeping—(Continued)

Linn, W. A. 637
McKelligan, A. S. 484, 526
McQuinn, H. P. 489
Moles, M. C. 472
Moore, Ralph F. 484
Pegram, Robert B. 484
Randolph, N. P. 691
Riddings, J. W. 150
Robinson, G. B. 295
Robinson, H. C. 586
Saul, G. W. 586
Seldon, J. 691
Sprar, Thomas 236
Stammers, John 484
Starratt, W. A. 484
Stevens, M. W. 484
Stone, E. T. 637
Taylor, F. W. 70, 586
Velasco, M. 180
Wagner, J. M. 586
Ward, G. C. 586
Whitton, W. C. 484
Williams, C. B. 484
Wood, L. B. 586
Wood, O. H. 637
Wright, W. F. 372
Yeakeme, George C. 372
Young, A. H. 236

Personals—Commission Appointments

Borland, Wilfred P. 494*
Chamberlain, S. A. 681
Hall, John G. 484
Pack, Alonzo M. 484
Patterson, W. J. 536
Robinson, Garland 295
Shirley, John A. 691
Thompson, John R. 691

Personals—Obituary

Ayres, Thomas A. 70
Bean, Stephen L. 373
Belnap, Hiram W. 637*
Billingham, R. A. 637
Boyd, G. A. 586
Eicher, Frank 373
Hills, H. S. 373
Hutchinson, A. E. 373
Kent, William C. 236
Lloyd, Henry R. 373
McManamy, John 691
Orchard, John H. 70
Percy, William 373
Porter, Charles D. 586*
Smith, Robert E. 637
Smith, Roy B. 637
Stewart, C. J. 429*
Taylor, E. W. 245*
Taylor, Joseph W. 586
Van Buren, C. W. 536, 586

Pickard, Frank C., Terminal handling of locomotives 275*
Pierce, Effect of the wage increase on piecework rates being revised 589*
Piecework system in railway shops, by W. J. McCleenan 411*
Pipe hanger, Portable, and E. I. Martin & Sons. 117*
Pipe line traffic in December. 152*
Piston and rod, U. S. standard heavy 2-8 type 491*
Piston rod keys, Machines for milling, A. T. & S. F. 37*
Piston rod packing, Hand power lathes for, M. St. P. & S. M. 627*
Pitard, J. H., Conservation of labor in the paint shop. 37*
Pitard, J. H., Standardizing painting and stenciling 620
Planer (see Machine tools)
Power plant, The losses in a small. 422
Power plants, Railroad. 74*
Pumps, Hydraulic, Hydraulic Press Mfg. Co. 365*
Pullman Co., Night light for sleeping cars. 119*
Pulverized coal tests, M. K. & T. 503
Pyrometers in spring making. 590*

Q

Quayle, Robert, The motive power department and fuel economy (Fuel convention) 352
Quayle, Robert, Responsibilities of railroad men 260

R

Railroad Administration

Appropriations for shops, Large. 349
Brakes, Maintenance of air. 568
Car department orders. 620
Cars, Reports, Instructions relating to. 459
Cars repairs, Limit of cost for freight. 613
Car situation, Bad order. 614
Car, Standard 55-ton hopper (photograph). 462*
Car, Standard steel sheathed body. 267*
Cars, Allocation of 100,000 standard. 512
Cars, Standard. 184*, 189*
Cars, Standard refrigerator. 663*

Railroad Administration—(Continued)

Fuel conservation section activities. 495
Locomotive orders, Standard. 300*, 369
Locomotive situation, Standard. 243*
Locomotives, Descriptions of standard (see Locomotives)
Locomotives, Distribution of the standard, to the railroads. 386
Locomotives, Rules for delivery and transfer of. 444
Locomotive Standardization. 246
Locomotives, Status of standard. 251*
Locomotives, The question of standard. 186*
News. 85, 133, 394, 494, 558, 604, 637
Organization chart, insert opposite page. 655
Paint orders. 517
Piecework rates being revised. 589*
Policy of the. Car and locomotive. 393
Specialty orders. Car and locomotive. 295, 481, 533
Superheaters, Schedule for the application. 444
Wage increases. Locomotive. 311*
Wage increase for mechanical department employees, Another. 470
Wages, Full day's work for a full day's pay, by George N. DeGuire. 681
Wages of shop employees, Interpretation of order increasing. 623
Wages, Shopmen's increase. 625
Wages to mechanical department men, Further increase in. 545
Railroad machinery catalogues wanted. 672*
Railroads and their relation to the fuel problem. The U. S. Locomotive (Fuel convention) 354
Rail stresses, Wheel arrangement and. 379*
Railway Devices Co., Sta-rite uncoupling lever attachment. 426*
Railways. Federal control of the. 4
Rauch, H. S., Practical results from modern apprenticeship. 362*
Ready Tool Co., Boring tool holder. 364*
Reamers, Peerless, Cleveland Twist Drill Co. 364*
Reamers, Something new in, Illinois Central. 219*
Reaming, Device used in, at right angles. 168
Reaming tapered holes to standard size. 285*
Reclaim and conserve material. 333
Reclamation of car axles. 431
Reclamation of high speed steel. 223*
Reclamation of scrap, Prevention of waste versus, by Henry J. Miller. 470
Reclamation on the Southern Pacific, by Frank A. Swearingen. 381, 505*
Reclamation plant, Billicera, Boston & Maine Red Cross Christmas roll call. The. 641*
Regional directors, Orders of. 394, 495, 560, 657
Repair facilities and materials, Co-ordinate, by J. H. Manning. 627
Repair facilities, The railroads lack proper. 185*
Repair problems, Freight car. 242*
Repair work, Do only necessary, by A. M. Reynolds. 33
Repair work, Systematize. 22
Repairs, Accuracy in locomotive, by M. H. Williams. 673*
Repairs, Better supervision of equipment. 379*
Repairs, Car wheels, and its cost. 433*
Repairs, Expedite locomotive, by George W. Armstrong. 341*
Repairs, Extend locomotive running. 23
Repairs, Limit of cost for freight cars. 613
Repairs, Passenger car terminal, by C. V. Fryer. 400
Repairs, Run repair or transfer, by F. W. Trapnell. 155
Report of I. C. C. division of safety. 17
Reports, Uniform engine failure. 642*
Results, The real test is to get, by Harvey DeWitt Wolcomb. 620
Reynolds, N. W. 267*
Locomotive. 405
Reynolds, H. W., Results of road tests of N. & W. Mallet locomotive. 502*
Rivets, Tight, American Flexible Bolt Co. 582*
Road locomotive, by George N. DeGuire. 485*
Rockford Tool Co., Balancing stand. 232*
Rockford Tool Co., Sundstrand tool room lathe. 173*
Rod end Automatic, for hard greases. E. Baldwin. 288*
Rod, Main, U. S. standard heavy 2-8 type Rod straps, Side. 491*
Rods, Main and side, by G. L. Lister. 283*
Roehsch, F. P., Improve the engine terminal facilities. 50
Roehsch, F. P., Traveling engineers and maintenance of locomotives, Traveling Engineers' convention. 552
Rogers, Edwin A., Conservation in fuel oil boiler plants. 599
Roofing for steel passenger cars. Treated cars. 289*
Ross, J. E., Protect equipment but keep it moving. 38
"Roll of honor," The railroad. 462*
Rubber gaskets, Chicago railway. N. W. 120*
Rubber gaskets, Save the, by C. J. Ruhland. 490*
Ruhland, C. J., Save the rubber gaskets. 490*
Rules of interchange, Changes in the M. C. R. 299*
Russian railways. Condition of. 478*

Ryan, T. T., Reducing the time to turn locomotives. 114
Myerson & Son, Joseph T., Seamless hollow staybolt iron. 634

S

Safety appliances, Equipping foreign cars with. 183*
Safety first, and safety last. 377*
Safety first: Why don't daddy come home by O. D. Boyle. 517
Safety inspector's report, I. C. C. 17
Safetyite items, Analyze carefully. 487*
Schane, C. W. An improvised hydraulic ram. 682*
Schaphorst, W. E., Lubricating oil density. 286*
Schenck, F. J., Setting eccentrics before engines are wheeled. 580*
Schmidt, Edward C., Railroads should make use of locomotive laboratory. 19
Schneider, A. J., Group insurance. 170
Schultz, F. W., Hot boxes on freight cars. 152
Schuster, Clays, The poor little rich bill. 320
Scrap, Machine for collecting barbed wire. 520*
Scrap, Manufacturing, into locomotive parts, by Paul H. Lippert. 576*
Scrap material, Utilize, by C. L. Dickler. 34
Scrap reclamation plant, Boston & Maine. 671*
Seal, A self-locking car, E. J. Brooks & Co., Inc. 532*
Seclert, E. W., Miscellaneous equipment at the Shoreham shops. 227*
Seclert, F. W., Some interesting boiler shop equipment. 167*
Seiders, I. A., Locomotive front end spark arrester. 118*
Shears, portable alligator. 103*
Shop equipment, Miscellaneous, at the Shoreham shops. 227*
Shop, A well organized repair, N. Y. C. 303
Shop facilities make for economy, Adequate. 128*

Shop Kinks

Air brake tester, Locomotive. 677
Air compressor table, Norfolk & Western. 159*
Air hammer attachment, Southern Railway. 519*
Alligator shears, Portable, N. Y. C. & St. L. 103*
Babbitt separator, by J. V. Henry. 422
Bench clamp, Pneumatic, Y. & M. V. 279*
Bench drill, Y. & M. V. 283*
Claw bar dies, Oregon Short Line. 116*
Close quarter drive and old man. 218*
Cotter key from old tubes, S. & W. 228*
Line. 228*
Crosshead facing tool, C. & A. 474*
Davis boring bar cutters, Prolonging the life of Missouri Pacific. 282*
Device for clamping air hose to coupling, N. Y. C. & St. L. 222*
Device for milling keys for eccentrics arms in crank pins, C. B. & S. 112*
Device for removing gaskets from sight pins and couplings, N. Y. C. & St. L. 222*
Device for removing boiler tubes, C. & N. W. 115*
Device for removing gaskets from sight feed lubricators. 224*
Drill jig for holding handrail columns, Soo Line. 227*
Drills, Novel method of driving. 624*
Eyebolts, Forming, on the bulldozer, C. M. & St. P. 624*
Fixture for holding eccentric straps, Soo Line. 227*
Form for habituating crosshead, Delaware & Hudson. 576*
Gages for driving box work, N. & W. 164*
Glass shields for grinding wheels, C. & N. W. P. 115*
Hand chisel guard, Erie Railroad. 278*
Hydraulic press for shortening draw-bars, C. & N. W. 681*
Hydraulic ram, by C. L. Dickler. 682*
Hydraulic superheater flue tester, Soo Line. 167*
Injector gage, by C. L. Dickler. 410*
Jack arrangement for use in changing passenger truck wheels, Southern. 221*
Jig for machining nuts, Canadian Pacific. 524*
Jig for reaming top heads of 3/4-in. air pumps, Norfolk & Western. 571*
Lathes for rod packing, Hand power, M. St. P. & S. M. 627*
Machine for finishing crown straps, Pa. Lines West. 519*
Machines for milling piston rod keys, A. T. & S. F. 37*
Mandrels for setting up. 285*
Pipe bender, Home-made, C. & E. T. 280*
Pneumatic riveting and shearing machine for coupler yokes, Soo Line. 227*
Radial staybolt caps, N. Y. C. & St. L. 167*
Rattler for flexible staybolt caps. 580*
Reamer for duplicating tapered holes, C. & A. 285*
Reamers with adjustable cutting edges and high speed blades, Illinois Central. 169*
Sill straightener, Steel car. 452*

*Illustrated article; †editorial; ‡short non-illustrated article or note; §communication.

Shop Kinks—(Continued)

Spring banding machine, Georgia Railroad 163*

Stenciling machine, A convenient, Soo Line 228*

Spring stripping machine, Maine Central 421*

Superheater blower, Soo Line 167*

Superheater beader grinding, C. & N. W. 113*

Turning up on punching rings, Special tool for, C. B. & O. 170*

W-block, A handy swivel, C. B. & O. 103*

Vedlock block for jacking locomotives, James Grant 680*

Yoke for use in removing elliptic truck springs, Southern 221*

Shop machine tool equipment needed, Harrison 209

Shop scheduling increases output, by F. J. 33

Shop scheduling on time, B. R. & O. 219*

Shop story with a moral, A. 112

Shops: Authorizations and expenditures chargeable to capital account (table) 657

Shops: Characteristics of railroad repair 235

Shops, Large appropriations for 349

Shops, Piecework system in railway, by W. McClellan 411*

Shops, Railroad efficiency depends on 242*

Shops, Women fill men's places in 23

Shopmen, Application of wage increases to 301*

Shopmen, Increase in wages for the railway 488*

Shops, Railway, on third efficient 921

Side rods (see Rods)

Skidmore, S., Back up the boys at the front by work 216

Stack action in long passenger trains (A. Brake Convention) 315

Slackers, There is no place for, on railroads 539*

Slowdowns, Time lost in, by Arthur Curran 592*

Slowdowns, The time lost in, by Walter V. Turner 497*

Smith, B. K., The difficulties of welding steel by the oxy-acetylene process 628

Smith, Joseph, Work on deck race 280*

Smolortsevsky, M. K., A system of labor compensation 325*

Snow and ice on the Pennsylvania 143*

Snow plows, Superheaters on rotary 598

Soldiers, Back up the, by work, by Skidmore 216

Soldiers, Magazines for 410*

Soldiers moved by railroads, Million and a 1150

Southern Pacific, Machining locomotive driving boxes 573*

Southern Pacific, Reclamation on the, by Frank A. Stanley 381*

Southern Railway, Air hammer attachment 505*

Southern Railway, Labor saving devices on the 221*

Spangrester, R. M., A. A. Series 118*

Specialty orders, The car and locomotive, 395, 483, 533

Specifications for U. S. standard cars 189*

Specifications, Tentative, of U. S. standard locomotives 251*

Sperl, Henry, Hand chisel guard 278*

Spidy, E. T., A method of regulating shop output 527*

Spring banding machine, Heical, by Albert H. Lake, Jr. 101*

Spring making, Pyrometers in 590*

Spring stripping machine, by J. M. MacDonald 421*

Springfield Machine Tool Co., Motor driven geared head lathe 357*

Standardization: Things fixed, by Millard F. Cox 592*

Stanley, Frank A., Machining locomotive driving boxes 573*

Stanley, Frank A., Milling practice in railroad shops 521*

Stanley, Frank A., Reclamation on the Southern Pacific 381*

Stationary plants, Fuel economy at 556

Statistics of railroad repair shops, Cons 255

Staybolt caps, Rattler for flexible 580*

Stayhold iron, Seamless hollow, Joseph T. Ryerson & Son 634

Steam consumption, by J. M. MacDonald 435*

Steam heat connection for cars, All-metal, Barco Mfg. Co. 176*

Steam heat end valve with automatic drip, Golf Car Heating and Lighting Co. 581*

Steam pipes, Method of applying outside, Locomotive Appliance Co. 119*

Steel, Higher sulphur and phosphorus limit 434*

Steel, Reclaiming high speed 225*

Steel tools, Tipping carbon, by W. H. Hailey 530*

Steel treating, Practice in lighting Co. Farland 164

Stoker locomotives, Watch fuel consumption of 541*

Stokes department, The real test is to get results, by Harvey DeWitt Wolcomb 409

Strauss & Buezelein, Goggles with non-breakable lenses 120*

Street, Clement F., Increase locomotive operating efficiency 5*

Stresses, Calculation of boiler, by G. E. Parks 139*

Stresses in bolts in fulcrum brackets, by Victor M. Summa 156*

Strong, E. W., Dynamic augment problem 257*

Stull, Howard W., Vacuum cleaner 102*

Summa, Victor M., Stresses in bolts in fulcrum brackets 156*

Summa, Victor M., The design of object beams 514*

Superheater beader, Grinding, C. & N. W. 113*

Superheater, Keep, plus performance 36

Superheaters, Scheduling the application, Engineering convention 652*

Superheater maintenance, Locomotive 621*

Superheater maintenance, The importance of, by H. T. Snow 36

Superheater return bends, Forged, Locomotive Superheater Co. 581*

Superheaters on rotary snow plows 598

Superheaters, Scheduling the application of, Railroad Administration 444

Supervision, Competent and adequate shop 184*

Supervision, Increased, necessary 73*

Supervision in the mechanical department, 591*

Supervision, Mechanical department, by Frank McManamy 597

Supervision of equipment repairs, Better 379*

Supervisors, Face Work secured, raise, by Harvey DeWitt Wolcomb 223

Supervision: When the "Old Man" showed his "pep," by Harvey DeWitt Wolcomb 625

Supply in the winter, by McAdoo 145

Suppliment tell of experiences in railway offices 55

Suppliment, Tips from chief clerks to 30

Supply Trade Notes

Abell-Howe Co. 297

Aldrich, E. K. 181

Allied Steel Casting Co. 431

American Abrasive Metals Co. 125

American Arch Co. 237*

American Brake Shoe & Foundry Co. 373, 537*

American Car & Foundry Co. 240*

American Flexible Bolt Co. 597*

American Locomotive Co. 219, 598, 638, 639*

American Rolling Mill Co. 486*

American Steel Foundries 485, 639*

Anchor Packing Co. 181, 629

Appar, J. D. 273

Asbestos Protected Metal Co. 181, 237

Atkinson, Lloyd H. 431, 638

Aubrey, H. M. 638

Auerbach, M. M. 638

Austin Co. 485, 691

Bailliere, M. V. 638

Baker, Richard W. 638

Baker, S. W. 638

Baldwin Locomotive Works 237, 485

Barco Mfg. Co. 181, 486

Barnitz, Harry L. 181, 486

Bartholomew, Frank W. 237, 485

Bartholomew, W. S. 237*

Basford Co. G. M. 537, 588

Baxter, Ernest 239

Beender, George W. 598*

Benning, Clyde P. 296*

Berry Brothers 296

Bettendorf Co. 237, 597

Better, A. J. 239

Biehlmier, G. W. 239

Bird-Archer Co. 485, 537

Bird, F. H. 71

Borowitz, W. M. 237, 430

Boyer, E. R. 537

Brach Supply Co. L. S. 181

Brown, Frank H. 638

Brown Hoisting Machinery Co. 373

Brown, R. S. 537, 588

Buckingham, J. E. 181

Buffalo Brake & Beam Co. 374*

Buker, Edward 638

Bunnell, F. O. 638

Burden Sales Co., Inc. 430

Camel 638

Carnahan, Robert B., Jr. 486*

Carnegie Steel Co. 237, 297

Carri, Robert F. 691

Carroll, C. G. 691

Carr, Edward F. 485

Casey, William 691

Certes Supply Co. 692

Chain Products Co. 692

Chase & Co., J. C. 374

Cheatham, Paul G. 638

Chicago Malleable Casting Co. 431

Chicago Pneumatic Tool Co. 239, 597, 637*, 485, 537, 587, 638, 691

Chicago Railway Equipment Co. 182

Chicolet, H. E. 537, 691

Christie, H. K. 537, 639*

Clark Car Co. 537, 639*

Clark, D. B. 298

Cleveland Milling Machine Co. 373

Cleveland Twist Drill Co. 124, 297*

Clyde, W. G. 431

Cole, A. R. 431

Coleman, W. 639

Colquhoun & Garrison, Co. C. R. 181

Cooper, H. S. 181

Cooper, R. S. 238

Covert, M. F. 638

Crandall Service, Bruce V. 537

Supply Trade Notes—(Continued)

Crawford, D. F. 431*

Crown, E. J. 181

Curtain, Supply Co. 374

Cutler, William F. 373

Damascus Brake Beam Co. 125*, 296

Davis, Ralph C. 125

Dixon Crucible Co., Joseph 374

Dayton Mfg. Co. 71

Dearborn Chemical Co. 538, 537

Delany, A. 537

Dillon, E. P. 587

Dixon, Robert M. 640*

Donne, Charles J. 298*

Doran & Co. 531

DuBois, Charles G. 692

Drake, Lauren J. 639

Durley, W. O. 125

Eades, Charles V. 125

Eckels, W. 538

Edison Storage Battery Co. 126

Edison Storage Battery Supply Co. 537

Edison, Thomas A. 237

Edmonds, John R. 639

Edmunds, Frank W. 431

Eklund, Karl J. 239

Elfhoff, H. J. 538

Ellis, William D. 374

Emery, Rufus F. 296

Emrick, M. 296

Fairbanks, Co. E. & T. 637

Fairbanks, Morse & Co. 181, 692

Finigan, Thomas 373

Flint Varnish & Color Works 373

Foley, Frank J. 126

Forsyth, Holmes 374

Fouse, Frank 126

Foyle, John W. 588

Frank, Robert E. 238

Franklin Railway Supply Co. of Canada, Ltd. 182

Fuller-Lehigh Co. 373

Furry, Frank W. 488

Galena Signal Oil Co. 238

Garratt-Callahon Co. 181

Hazier, Mfg. Co. 71, 588

Gleason, D. 71

Gleason Co. 71*

Globe Seamless Steel Tubes Co. 537, 587*, 691, 885

Goodnow, Charles E. 639

Greaves-Klusman Tool Co. 71

Gruhn, E. O. 588

Grip Nut Co. 239, 296, 691

Gunton, P. C. 124

Gustin-Bacon Mfg. Co. 588

Hall, Frank 125

Halls-Cott Motor 691

Haskell & Barker Car Co. 485

Hasse, Frank C. 485

Hasse, O. A. 71

Henry, J. 181

Helmright, R. J. 237*

Hofas Steel & Equipment Co. 72

Hopewell, Frank 638

Hopkins, J. 638

Hopkins, John P. 640

Horsburgh, R. H. 72*

Horton, W. D. 237

Hurley, Frank 237

Hutchins Car Roofing Co. 238

Hyatt Roller Bearing Co. 72, 124

Independent Pneumatic Tool Co. 692

International 238, 375, 537, 640, 639

International Oxygen Co. 296, 639

International Seal & Lock Co. 691

Irvin, Paul T. 238

Jackson, H. A. 237

Jenks, Charles D. 125

Johns-Manville Co., H. W. 237, 297, 430

Jordan, Francis 691

Jude, A. D. 71

Kauf, John F. 485*

Kansas City Bolt & Nut Co. 239

Keigh, Marshall E. 537

Kennedy Press Co. 374, 538

King, W. 485

Koch & Sandidge 485

Lakonda Mfg. Co. 485, 538

Lamont, Lieut. Col. R. P. 124, 639

Lapierre, G. 639

Larsen, L. A. 181

Leidenger, Peter 71

Lewis, G. R. 239

Liberty Car & Equipment Co. 296

Liberty Steel Products Co. 430, 691

Lima Locomotive Works 181, 239*, 537, 638

Lincoln Twist Drill Co. 124

Locomotive Feed Water Heater Co. 126

Locomotive Lubricator Co. 538

Locomotive Pulverized Fuel Co. 238*, 638

Locomotive Stoker Company 431, 537

Lone, John P. 537

Love, L. S. 71

Lovekin, W. H. Engineering Co. 71, 691

Luber, L. L. Co. 124, 296

Maloney Oil & Mfg. Co. 296

Marsh Refrigerator Service Co. 126

Marshall, Waldo B. 435

Mason, Stephen C. 373, 432

Mathan, C. B. 692

McKenney, L. C. 691

McConway & Torley Co. 437*

McGard & Co. 373

*Illustrated article; †editorial; ‡short non-illustrated article or note; †††communication.

Supply Trade Notes—(Continued)

McCullum, T. 181
 McCune, Charles 430*
 McKen Aerator Car Co. 692
 McNulty, J. A. 181
 Mercury, H. B. 691
 Metal & Thermite Corporation 181, 537
 Midgley, Stanley W. 430*
 Mineral Rubber Products Co. 125
 Mudge & Co. 239*
 Murphy, Charles 485*
 Murrian, W. S. 432
 Musgrave, George H. 538
 National Railway Devices Co. 638
 Norton, C. 638
 Nuttall Co., R. D. 125
 O'Brien, F. J. 587*
 Ohio Brass Co. 296
 Ohio Electric & Chemical Co. 374
 Ohio Injector Co. 638*
 Okalee Co. 587
 Onondaga Steel Co. 124
 Orenstein-Arthur Koppel Co. 239
 Osborne, Loyall A. 588
 Ostby, Oscar E. 72, 588*, 638
 Ostrander, A. E. 240*
 Oxwell Railway Service Co. 124
 Pacific Car & Foundry Co. 374
 Page, P. W. 124
 Pace Steel & Wire Co. 430*
 Parish, Le Grand 639
 Parishburg Iron Works 430
 Patterson, H. S. 374
 Patton, J. C. 237
 Payne, N. B. 72
 Peck, E. C. 238
 Permutit Co. 238
 Perolin Railway Service Co. 71*
 Pettibone-Mulliken Co. 71*
 Pittsburgh Testing Laboratory 374
 Pfeiffer, George C. 373, 431
 Pressed Steel Car Co. 124
 Price, J. L. 238
 Protectus Paint Co. 485
 Pullman Co. 430, 431, 537
 O & C Co. of Canada, Ltd. 691
 Quigley Furnace Specialties Co., Inc. 488
 Raiback Paint Co. 485
 Raiston Steel Car Co. 485
 Reid, W. J. 239
 Riordan, J. M. 374
 Roberts & Schaefer Co. 296, 374
 Roberts, Lieut.-Col. W. R. 375*
 Robinson, G. P. 295, 638
 Rosing, W. L. 240, 637
 Roder, J. H. 239
 Rogers, Ira C. 239
 Rose Iron Mills, Inc. 374
 Roning, W. H. V. 537
 Rupert, Milton 125
 Safety Car Heating & Lighting Co. 587, 639, 640*
 Savage, H. D. 238*
 Schlacks, W. J. 538
 Schomaker, J. 238
 Schroeder Headlight Co. 181, 296
 Schroeder Headlight & Generator Co. 431*
 Sellers Mfg. Co. 639
 Sharp, J. B. 71
 Sherritt & Steer Co. 537, 639
 Simmons, E. A. 181
 Smith, Cameron 125
 Smith & Henway Co. 430
 Southern Locomotive Valve Gear Co. 432
 Southern Railway Supply & Equipment Co. 373
 Southern Wheel Co. 373, 638
 Sprague Electric Works of General Electric Co. 125, 430
 Sprague, L. C. 485, 587, 691
 Standard Car Construction Co. 638
 Standard Coupler Co. 373
 Standard Forgings Co. 239
 Star Brass Mfg. Co. 538
 Stram, A. 691
 Stutsman, R. G. 373
 Superior Side Bearing Co. 181
 Swinerton, T. H. 638
 Tarnburgh, J. N. 239
 Tierney, H. J. 181
 Tiltman, Ralph F. 124
 Trauor, James A. 587*
 Tripp, B. H. 588*
 Trinity City Rubber Co. 125*
 Turner, Walter V. 431
 Tyden, Col. E. 691
 Underfeed Stoker Co. 430
 Union Railway Equipment Co. 72
 Union Steel Casting Co. 124, 181
 Union Supply Co. 72, 124, 485
 United States Metallic Packing Co. 430, 637
 United States Rubber Co. 431
 Van Dorn, William T. 691
 Van Houten, R. A. 125
 Vansinger & Co., Harry 587
 Wagner, W. 538
 Waestaff, P. M. 124
 Walworth Mfg. Co. 374
 Weedon, J. C. W. 587
 Weinland, Joseph W. 430, 691
 Weinskeiner, A. S. 431
 Wendt Co., P. W. 296
 Wesley, Phillips 639
 Western Electric Co. 637, 296*, 486
 Westinghouse Air Brake Co. 237*

Supply Trade Notes—(Continued)

Westinghouse Electric & Mfg. Co. 72, 125*, 181, 431, 538
 White American Locomotive Sander Co. 72
 White, J. W. 72
 Wilkloessen, F. S. 238*
 Wildin, George W. 238*, 486
 Wilson, C. H. 181
 Wilson Welder & Metals Co. 691
 Wilson Railway Apparatus Co. 124
 Winger, S. D. 124
 Wood, E. 537
 Wright, Charles P. 430
 H. D. 638
 Zeller Supply Co. W. A. 181, 639, 587
 Zimmerman, Fred G. 587
 Sweeley, E. A., Should the master car builders' repair card be abolished during the period of the war? 266
 Switching and its effect on car repairs, Careless 433*

T

Taylor, Joseph W., A statement of the purpose of the M. C. B. Association. 398
 Taylor, Joseph W.—In memoriam. 245*
 Taylor, F. W., Build spare fireboxes. 35
 Taylor, F. W., Co-operate to reduce engine failures. 22
 Taylor, E. W., Keep engines on the road. 52
 Test plant, Railroads should make use of, by Edward C. Schmidt. 19
 Tests, M. K. & T. pulverized coal. 503
 Tests of the A. S. A. brake, Road. 453*
 Tests of N. W. Mallet locomotive, Results of road by H. W. Reynolds. 502*
 Tests of oxy-acetylene welded joints in steam plates. 111*
 Tests, Result of road, with Union Pacific 2-10-2 type locomotive. 323*
 Tests, University of Illinois coil. 80*
 Tests, for thrifting for lead, H. E. Harris Engineering Co. 290*
 Thread gages, Angle and lead testing machine for, H. E. Harris Engineering Co. 290*
 Throttle safety appliance, M. K. & T. 228*
 The shortage of wood, mentioned by S. T. Davis, scientific study of, welded, by W. Miller 104*
 Tohensura Weno gives some advice. 490
 Tohensura Weno's spy work comes to naught. Tonnage rating charts for standard locomotives. 764
 Tool lubrication, Cutting, by R. B. Huyett. 282
 Tool room, The railway shop, by M. H. Williams 335*
 Tools, Inserted cutter, Lovejoy Tool Co., Inc. 479*
 Tools, Standard file heading, A. & T. 217*
 Tools, Tipping carbon steel, by W. H. Halstead 530*
 Tractor, Three-wheel, Elwell-Parker Electric Co. 475*
 Train breaks and the coal pile (fuel convention). 353
 Trapnell, F. W., Run repair or transfer. 155
 Traveling engineers and general air brake inspectors, Co-operation of, Traveling Engineers' convention 553
 Traveling Engineers' Association convention report for 1917. 547*
 Traveling engineers' convention, The 540S
 Traveling engineers help win the war, How can 488S
 Trimby, Charles, Prolonging the life of Davis boring bar cutters. 282*
 Truck, A high lift industrial, Lewis Shepard Co. 176*
 Truck, Six-wheel tender, N. & W. 445*
 Truck, U. S. standard 50-ton. 189
 Trucks, Standard flat heading, A. & T. 189
 Trucks, bolsters, Predict car and tender, by G. S. Chiles and R. G. Kelley. 270*
 Truck box lubricator, Locomotive, J. C. Martin 425*
 Trucking for steel passing, cars. 280
 Tubes, Removing boiler, C. & N. W. 115*
 Tubes, Welding, in the firebox. 110
 Tucco Products Corporation, Treated canvas roofing for steel passing, cars. 289*
 Turner, Walter V., The time lost in slow-downs 497*

U

Uncoupling lever attachment, Star-rite, Railway Devices Co. 426*
 Underframe reinforcing for wooden furniture cars 91*
 Union Pacific 2-10-2 type locomotives. 321*
 United Hammer Co., Power hammer attachment 288*
 United States Railroad Administration (see Railroad Administration).
 University of Illinois coil tests. 80*
 Universities and equipment development. 47

V

V-block, A handy swivel, C. B. & Q. 103*
 Valve chest for slide valve cylinders, Inside admission piston, Franklin Railway Supply Co. 684*
 Valve gear, Anderson. 424*
 Valve, inside connects vapor, Call Car Heating & Lighting Co. 634*
 Valve rod packing, Hand power lathes for, M. St. F. & S. S. M. 627*
 Vincent, H. S., Locomotive feedwater heating 645*
 Virginian Railway, 2-10-1-2 locomotives. 600*
 Vise and bench, A portable, Henderson Electric Co. 175*
 Vise, A new milling machine, Cleveland Milling Machine Co. 66*
 Vise, Milling machine, Edlund Machinery Co., Inc. 685*
 Vise, New idea, Barnett Foundry & Machine Co. 476*
 Vise stand and pipe bender, Portable, H. P. Martin & Sons 117*

W

Wage increase and the supervising foreman, The 488S
 Wage increase for mechanical department employees, Another 470
 Wage increases for railway men 311*
 Wage increase on piecwork, Effect of the increases, Application of, to shopmen 488S
 Wages are increased, Shopmen 525
 Wages, Coach cleaners' 564
 Wages for the railway shopmen, Increase in 488S
 Wages of shop employees, Interpretation of order increasing 623
 Wages to mechanical department men, Further increase in 545
 Wages: Full day's work for a full day's pay 642S
 Wages: Full day's work for a full day's pay, by George N. DeGure. 681
 Walk, S. U., Boiler brace coupling. 231*
 Wallace & Co., J. D., New type of machine for woodworking 424*
 War Savings Stamp campaign 221*
 War Savings Stamp nursery rhyme 386
 War Savings Stamps: Every little bit helps do a little bit more 530
 War Savings Stamps, The meaning of, by Jack Cutler 392
 War, The railways in the, by S. O. Dunn, Traveling Engineers' convention. 549
 War, The winning of the depends on output 299S
 Waste, Prevention of, versus reclamation of scrap, by Henry J. Miller. 470
 Water-power, Trains by 450S*
 Water treatment, Boiler scale and, by George Austin 161*
 Way, E. S., The tank car in interchange. 97*
 Wedge bit for jacking locomotives, by James Grant 680*
 Weld, A difficult cylinder, by D. A. Donaldson 277*
 Welds, Metallic electrode arc, by O. S. E. Holz 416*
 Welded tires, Microscopic study of, by S. W. Miller 104*
 Welding, Electric, reduces boiler repairs. 36
 Welding firebox patches and cracks, by E. D. Johnson 520*
 Welding for shipbuilding, Electric. 530*
 Welding methods at Columbus shops. 473*
 Welding, Oxy-acetylene and electric, by A. Dyer 571-
 Welding steel by the oxy-acetylene process, The difficulties of, by B. K. Smith. 628
 Welding: Tests of oxy-acetylene welded joints in steel plates. 111*
 Welding, The cost of oxy-acetylene. 527
 Welding tool, with positive electrode clamp, Arc Welding Machine Co., Inc. 685*
 Welding tubes in the firebox. 110
 Westinghouse Air Brake Co., Air valve lift gage for locomotive air pumps. 231*
 Westinghouse Air Brake Co., Lose mounting and clamping machines. 683*
 Wheel arrangement and rail stresses. 379S
 Wheel drop pit, Car, by J. V. Henry. 356*
 Wheel shop, New devices in Soo Line. 577*
 Wheels, Changing freight car. 378S
 Wheels, The grinding of car. 342S
 Wickman, J. H., Railway shop fans and blowers 166
 Williams, E. V., Train the new men. 34
 Williams, M. H., Accuracy in locomotive repairs 673*
 Williams, M. H., Bolt manufacture in railroad shops 465*
 Williams, M. H., Grinding in locomotive shops 629*
 Williams, M. H., Plain knee type and similar milling machines 41*
 Williams, M. H., The railway shop tool room 335*

*Illustrated article; †editorial; ‡short non-illustrated article or note; §communication.

Widmarth & Morman Co., Drill grinders...	65*	Woman worker in railroad shops, The, by Harvey DeWitt Wolcomb.....	25	Wood, Professor A. J., Co-operative "rail-road-college" course.....	19
Wilmott, W. K., Efficiency in the car department.....	461	Women fill men's places in shops.....	23	Wright, J. D., Paint only for preservation.	38
Winter, Last call to prepare for.....	541§	Women in railroad shop work, The field for, by Margaret Lampert.....	25		
Wolcomb, Harvey DeWitt, How Jack Wingate secured a raise.....	223	Women workers, Selection and training of, by D. C. Buell.....	23		
Wolcomb, Harvey DeWitt, The female worker in railroad shops.....	25	Wood, H. F., Piston travel and braking power.....	662	Yazoo & Mississippi Valley, Bench drill....	283*
Wolcomb, Harvey DeWitt, The real test is to get results.....	409	Wood milling machine, Oliver Machinery Co.....	291*	Yazoo & Mississippi Valley, Pneumatic bench clamp.....	279*
Wolcomb, Harvey DeWitt, When the "Old Man" showed his "pep".....	625	Wood planer, A portable, J. D. Wallace & Co.....	424*	Yoder, J. H., Improved apprenticeship methods on the Pennsylvania.....	8*
				Young, E. W., Don't neglect the boiler....	35

Y

*Illustrated article; §editorial; †short non-illustrated article or note; ‡communication.

Railway Mechanical Engineer

CONTENTS FOR JANUARY, 1918

	Page
Hon. William G. McAdoo.....	2
The Duty of the Railway Man.....	3
Federal Control of the Railways.....	4
Increase Locomotive Operating Efficiency, by Clement F. Street.....	5
Improved Apprenticeship Methods on the Pennsylvania, by J. H. Yoder	8
The Railroad Roll of Honor.....	11
The Improper Loading of Lumber.....	15
Mechanical Department Overlooking a Real Opportunity.....	18
More Service from the Equipment.....	21
Women Fill Men's Places in Shops.....	23
The Mechanical Engineer.....	27
Tips from Chief Clerks to Supplymen.....	30
Locomotive Maintenance Problem.....	33
Painters Must Protect Equipment.....	38
Plain Knee Type and Similar Milling Machines, by M. H. Williams..	41
The Universities and Equipment Development.....	47
Increase Engine Terminal Output.....	50
Repair the Cars and Keep Them Moving.....	53
Supplymen Tell of Experiences in Railway Offices.....	55
New Locomotive Orders in 1917.....	58
The Freight Car Orders in 1917.....	60
New Devices.....	63
News.....	67



Copyright by Harris & Ewing

Hon. William G. McAdoo

Secretary of the Treasury and Now Also Director General of Railroads

THE DUTY OF THE RAILWAY MAN

You Are Now Working for the Government.

You Have Been Drafted Into the Service of Your Country.

By Proclamation, President Wilson Has Taken Over the Railroads that Our Country Might Better Do Its Part in the War.

As You Owe Allegiance to Your Country You Now Owe Allegiance to Your Job.

Your New Chief—Director-General McAdoo—Wants Your Help. He Needs You. Give Him the Best that Is in You. Stick to Your Work and Do It Right. Read His Appeal to You:

“THIS is a time of great stress, and the attitude of every employee should be determined by the supreme need of the hour—duty to his country first of all. I cannot state too strongly the necessity for devoted and loyal service by every man in this emergency. Every railroad employee is now in effect a government employee and as much in duty bound to give his best service to his country as if he wore the uniform of the United States army and occupied the trenches at the front. Every unnecessary delay in a train movement vitally affects our soldiers and sailors and seriously impairs our ability to defend our rights and our liberties. Every man whose neglect or indifference causes such delays may be responsible for the loss of the son of some

noble American mother or father. It is as serious to the country for an employee to be a slacker in his work as for a man to be a slacker in the army.

“The present serious congestion and actual suffering for the want of coal and other supplies will be greatly improved and may be entirely remedied if every employee will do his utmost in his individual task. In the name of patriotism, therefore, for the protection of our sons abroad and for the safety of the nation, I hope that every man, wherever placed, will do his level best. Let us who stay at home be ashamed not to be willing to make sacrifices equally as great as those our gallant sons are already making for us on the bloody fields of France.”

If You Never Appreciated the Importance of Your Position in This World Struggle, You Should at This Time.

You Are the Men Behind the Men Behind the Guns. *Back Them Up.* Show Your Mettle as They Are Showing Theirs.

They Depend Upon You.

The Country Depends Upon You.

The Allies Depend Upon You.

The World Depends Upon You.

DO YOUR BIT AND DO IT WELL!

FEDERAL CONTROL OF THE RAILWAYS

Honorable William G. McAdoo Made Director-General; Requests Full Support of Railway Men

THE past few weeks have been full of interest to all railway men. On December 26 President Wilson issued a proclamation taking over the possession and operation of the railways of the United States—"It is necessary for the complete mobilization of our resources that the transportation systems of the country should be organized and employed under a single authority and a simplified method of co-ordination, which have not been proved possible under private management and control," he said.

Hon. William G. McAdoo, Secretary of the Treasury, was appointed director-general and took control of the roads at noon, December 28. He is to be assisted in his gigantic task by a committee of advisors or cabinet made up of J. S. Williams, controller of the currency and formerly president of the Seaboard Air Line; Hale Holden, president of the Chicago, Burlington & Quincy, and a member of the former Railroads' War Board; Henry Walters, chairman of the Atlantic Coast Line; Edward Chambers, vice-president of the Atchison, Topeka & Santa Fe, and Walker D. Hines, chairman of the executive committee of the Atchison, Topeka & Santa Fe. A. H. Smith, president of the New York Central, was appointed temporary assistant to the director-general.

In his first order Director-General McAdoo outlined the status of the employees and the railroads. He said:

"All officers, agents and employees of transportation systems may continue in the performance of their present regular duties, reporting to the same officers as heretofore and on the same terms of employment.

"Any officer, agent or employee desiring to retire from his employment shall give the usual and reasonable notice to the proper officer, to the end that there may be no interruption or impairment of the transportation service required for the successful conduct of the war and the needs of general commerce.

"All transportation systems covered by proclamation and order shall be operated as a national system of transportation, the common and national needs being in all instances held paramount to any actual or supposed corporate advantage. All terminals, ports, locomotives, rolling stock and other transportation facilities are to be fully utilized to carry out this purpose without regard to ownership."

The railroads will continue to be operated directly by their own officers except and until the director-general shall find occasion to order a change. They will be given "a square deal," he has promised, and every opportunity to make good, with such help as the Government can give them and under the presumption that they will not be disturbed except for good cause. Of course, the director-general's power is paramount, but his authority is superimposed upon that of the existing organizations and not substituted for it. His purpose is to secure the greatest possible efficiency from the use of the existing instrumentalities of the railroads, and he believes that with the individual interests of the railroad companies absolutely submerged by the Government guarantee it will be possible to work out many plans for co-ordinating their facilities which have been impracticable for the railroads under the prohibition of the laws and under the pressure of their individual interests.

On Monday, January 8, the director-general issued the following appeal to all railroad employees with the request that it be posted by all railroads:

"The Government of the United States having assumed possession and control of the railroads for the period of

the present war with Germany, it becomes more than ever obligatory upon every officer and employee of the railroads to apply himself with unreserved energy and unquestioned loyalty to his work.

"The supreme interests of the nation have compelled the drafting of a great army of our best young men and sending them to the bloody fields of France to fight for the lives and liberties of those who stay at home. The sacrifices we are exacting of these noble American boys call to us who stay at home with an irresistible appeal to support them with our most unselfish labor and effort in the work we must do at home, if our armies are to save America from the serious dangers that confront her. Upon the railroads rests a grave responsibility for the success of the war. The railroads cannot be efficiently operated without the whole-hearted and loyal support of every one in the service from the highest to the lowest.

"I earnestly appeal to you to apply yourselves with new devotion and energy to your work, to keep trains moving on schedule time and to meet the demands upon the transportation lines, so that our soldiers and sailors may want for nothing which will enable them to fight the enemy to a standstill and win a glorious victory for united America.

"Every railroad officer and employee is now, in effect, in the service of the United States, and every officer and employee is just as important a factor in winning the war as the men in uniform who are fighting in the trenches.

"I am giving careful consideration to the problems of railroad employees, and every effort will be made to deal with these problems justly and fairly and at the earliest possible moment. There should be a new incentive to every one in railroad service while under government direction to acquit himself with honor and credit to himself and to the country."

CONGESTION INVESTIGATED

On January 1 Commissioner McChord of the Interstate Commerce Commission made an investigation of the congestion of the railways in the east for the director-general. He has received reports from inspectors at the principal terminals which showed that there is a considerable shortage of power on many roads, a shortage of labor and material to repair the cars and locomotives, and that there is a large number of bad order cars. On the lines of the Pennsylvania Lines West at the Conway yard in Pittsburgh, there were reported 1,744 bad order cars out of a total of 6,379 cars on hand. There were 32 locomotives at that terminal, none of which were O. K. for service.

On the Baltimore & Ohio at Philadelphia there were seven B. & O. and one U. S. locomotive frozen, and 15 additional locomotives were out of service for repairs.

The New York, New Haven & Hartford was in the worst condition. On December 31 it was reported that of 1,081 locomotives assigned to various divisions, 303 were in shop for repairs. Power is needed badly. There is a shortage of material for repairs. It was also reported that locomotives were leaving terminals without proper repairs, causing delays en route. Of 60 locomotives assigned to road freight service on the Hartford division, 22 were in shops.

The locomotive situation in the east is relieved somewhat, as now the Russian orders are being held back and 90 to 100 of the Russian engines have been taken for use here as well as about 100 locomotives built for General Pershing's army which could be spared for a time. Also 165 locomotives which were for the western lines are to remain in the east.

INCREASE LOCOMOTIVE OPERATING EFFICIENCY

BY

CLEMENT F. STREET



DURING the past ten years more improvements have been made in the locomotives in use on the railroads of this country than in any other equal period since the first locomotive was built. The most radical have been in the dimensions and power, and to-day there are hundreds of them in service which ten years ago would have been thought entirely impractical, if not impossible, from either standpoint. Many important improvements have also been made in designs as well as in the way of attachments and appliances for increasing their efficiency, and today they are producing a horsepower at the drawbar at a cost in pounds of coal which ten years ago would have been considered impossible of attainment. The end is not yet, and while ten, and even twenty, years ago we would frequently hear that the maximum had been reached in both power and efficiency, today we seldom hear such a remark, and many promising improvements are under way.

We have been reading and hearing much about all of these things, but we read and hear very little about the improvements which have been, and are, being made in the operation of locomotives, with a view of increasing their earnings. It is the purpose of this article to treat with some features of this subject.

A locomotive is the only thing on a railroad which earns money. When the locomotives on a railroad are working to their maximum capacity, both in tonnage hauled and time pulling trains, the earnings of that road are at their maximum. Consequently, the primary efforts of railway operating officers are constantly being directed to the problem of loading locomotives to full capacity and keeping them moving.

THE ENGINE HOUSE

The engine house comes very near being the key to the whole question of locomotive earnings. The best designed, best built and best operated locomotives in existence will not make a good record unless they are backed up by a good engine house, and poor locomotives, with the backing of a good engine house will make a better showing than good locomotives with a poor engine house.

It has, for many years, and in all lines of manufacture, been well understood that it pays to give workmen a comfortable place in which to work, and good tools to work with, and railroad managers recognize the fact that this applies to an engine house. As a result, the design and layout of modern engine houses has been given careful study by competent engineers, and they are just as great an improvement over the old ones as the modern locomotives are over the old locomotives. The question of their location has been given careful study, and they are so placed as to cause the least loss of time in locomotive turnings. They are of concrete, or other fireproof material, with many windows of large dimensions, which give good daylight; they have

TO GET THE BEST efficiency from a locomotive it must be properly maintained. This means that there must be adequate repair facilities at engine houses. This is axiomatic, yet there are many, many cases where the engine house facilities have been almost entirely ignored. Anything *was* good enough for the engine house. Today the railways, through the shortage of power, are finding how necessary well equipped and well organized engine house forces really are. In the future, if the lesson is properly learned, there will be nothing too good for the engine house.

New power has not been obtained on account of the price and the scarcity of materials. The existing power must be worked to the limit of capacity. Improvements that will increase the operating efficiency of locomotives should and must be made. They are necessary in the interests of the welfare of the nation.

well-laid floors, which can be kept dry and clean with little trouble; they have good heating and electric lighting systems, and also equipment for washing out boilers with hot water; they have a machine shop under the same roof—not a half mile away—and this shop has a full equipment of all the tools required for making the regular engine house repairs. A storehouse is also under the same roof, from which all supplies can be drawn for both repairs and running. The

oil house is located just as near as it is safe to locate it, and a regular man in charge saves time and waste in promptly dealing out supplies, and also reduces fire risk. With good equipment, such as this, good results are being obtained.

On the other hand, many old engine houses are still in existence—dismal buildings—where we see men groping around in the dark, without adequate heating, lighting, or ventilating systems, wading through water, mud and ashes, at long distances from machine tools and supplies, and the only wonder is that they do as well as they do. The latter conditions do not exist by choice, but by necessity, and where we do find them, we also find that the road maintaining them does not have the money with which to make necessary improvements. The day in which anything was considered good enough for an engine house has gone.

Engine house supervision is being given attention because it also is of vital importance. In fact, it is fully as important as good buildings and equipment, for the reason that the saying that "a good workman with poor tools will produce better results than will a poor workman with good tools," will apply to an engine house. The job of the engine house foreman is not much sought after, and this is not as it should be, as it affords an unusual opportunity for a man to show his real ability. Any man who can make an unqualified success as an engine-house foreman is fully equipped for the next step in advance to the position of master mechanic.

The customary, but not universal, practice is to take a shop-man for this job, and preferably one who has had experience as a locomotive engineer, which is all right. Men who have both these qualifications are, however, growing more and more difficult to secure, and it might be found advantageous to institute a regular system of training for the position. Very few men go from the shop to the road, or from the road to the shop. If it was more generally understood that men who did do this would be the first to have consideration for advancement, more of them would do it, and the result would be that the railroads would have a larger number of men from which to make selections for this position.

The engine house has much to do with locomotive mileage between shoppings. By "babying" a machine, and giving it an elaborate and expensive supervision, it is possible to bring this up to unusual figures. A sample of what can be done along this line is in the records of the Chicago, Milwaukee & St. Paul. A 16 in. by 24 in. eight-wheel locomotive was built at the West Milwaukee shops, and placed in service in October, 1889. It was not taken in the shops for general repairs until October, 1893, a period of four years, and during this time the engine made an aggregate of 224,907 miles, or an average of nearly 4,700 miles per month. Of course, a great many running repairs were made, such as tire changing, renewal of driving-box brasses, etc., at the engine house. During this period, the locomotive received the best care it was possible to give it. It was on a regular run, in charge of a regular crew on a long run, and was "babied" to an extent which would hardly seem to be practical in regular operation. This is one instance, and is merely an example of what can be done when every possible effort is centered on one locomotive.

LOCOMOTIVE MILEAGE

It used to be quite generally accepted that one hundred miles was a day's run for a locomotive, and that after making this mileage it must go to the engine house. It has, however, for many years been understood that this was not the best practice, and that a greater mileage than this should be made. As far back as 1888, J. H. Setchel, in his presidential address to the Railway Master Mechanics' Association, said: "Locomotives should wear out and not rust out, and when this is properly understood and acted on, loco-

tives will run six and eight thousand miles per month, where they now run three or four at the most." The truth of this statement was generally understood at that time, and has never been challenged. While the subject has been many times discussed, all of the discussion has been regarding the best means for accomplishing an end, the desirability of which was a foregone conclusion.

So far as the locomotive as a machine is concerned, a run of one hundred miles (barring delays) is not much more than a good warming up, and there is no reason why it should not run three hundred or four hundred miles a day. The arrangement of crews is another question, and also that of turning points and terminals. A practical and advantageous solution of both of these is beset with troublesome and annoying problems, but none of them are insurmountable, and they have been, and are being, solved. As a result, we have locomotives regularly assigned to runs aggregating three hundred and four hundred miles per day in freight service. In order to make this mileage, a locomotive cannot be held on side tracks, but must be kept moving. Right here is where another great advance has been made in railroad operation. The stopping and holding of a freight train for trivial reasons used to be a common occurrence, but this is no longer the case. With double tracks, good signal systems and good despatching, it is possible to run an entire division without stopping, except for water. One of the most wasteful and vicious practices ever instituted on our railroads was the stopping of freight trains for orders, and this is being rapidly relegated to the scrap pile, where it belongs.

The stopping of a five or six thousand ton train without good and sufficient reason is a serious offense against good operation, and it is being looked upon as such and treated accordingly.

A number of years ago I was on a locomotive hauling 4,600 tons when a track foreman held a red flag in front of it, until it came to a dead stop, with the train standing on a curve, and then stepped aside and signaled to go ahead. In trying to start, two drawbars were pulled out, and it was two hours before the train was again under way. By this time three or four additional trains were lined up behind it, and one track of the division was tied up. The trackmen were only leveling up the tracks and tamping ties, and the train could just as well have been allowed to keep moving at a low speed, as there was not the slightest danger of a derailment. These things are now being watched more closely, and this could not occur today.

COAL

There has probably been more said and more written about coal than any other subject in connection with the operation of locomotives, and coal saving has been so well thrashed out that there would seem to be little left to say, but, like the poor, this is always with us, and always will be.

While, from some points of view, we have made wonderful progress in coal saving, from others, we have hardly scratched the surface. One of the latter is in regard to the size, or physical condition of the coal. It was formerly believed that the chemical analysis was the only test, and only two grades as to size were generally used, viz.: run-of-mine and slack. On some roads lump was supplied for passenger runs, but, as a rule, run-of-mine was used. It was also generally believed that there were only two grades of coal as to quality, that is, good coal and poor coal.

Both these beliefs are rapidly being changed, and it is becoming recognized that what is good coal for one locomotive might be poor coal for another, and coal which would result in a locomotive failure on one locomotive would give perfect results on another. There are to-day large numbers of locomotives running and giving excellent results with grades of coal, which, five years ago, were considered so poor as to be useless. This has been accomplished by fitting the

locomotives with appliances specially designed to enable them to burn low grade coal.

The question of the size of coal is of such importance that a committee was appointed by the International Railway Fuel Association to conduct a series of tests, the main object of which was to determine the most desirable size of bituminous coal to use on locomotives. A complete and exhaustive series of tests was made by this committee at the University of Illinois, during which six different sizes of coal were tested. The bituminous coal operators have for some time been grading their produce as to size to a limited extent, and, under normal conditions, this practice will be extended more and more, as it has been found advantageous to both the producer and consumer. The probability is that at no very distant day the grading of bituminous coal as to size will, under normal conditions, be just as complete and just as universal as is the grading of anthracite.

Locomotive coaling plants are now being built to provide for the handling of different sizes of coal, and this practice will, under normal conditions, be extended. This necessitates a more careful supervision of these plants, and the men in charge must be of a higher grade of intelligence than formerly.

Some railroads are using a mixture of anthracite and bituminous coal and formerly they were put on the tanks in alternate layers and the fireman depended upon to see that the mixing was properly completed. This practice is being improved on by the installation of mechanical mixing plants in which the two coals are thoroughly and mechanically mixed in the coaling station and before being put on the tender of the locomotive. The results from this practice have been found to be of sufficient advantage to more than compensate for the slight additional expense.

In fact, it is now well recognized that it is a good investment to go to almost any trouble and expense to see that the coal placed on the tank of a locomotive is of such a character as to preclude any danger of a locomotive derailing or failure which the crew could claim was due to the coal.

THE FIREMAN

The instruction of firemen is being given more attention than formerly, as it is well understood that with improper firing, twenty to thirty per cent of the coal is wasted. There are to-day more traveling firemen employed than ever before, and the practice of employing them is being extended, as they are found a good investment, not only because of the saving they make in the coal burned, but also in the reduction in train delays owing to failures for steam due to bad firing. Furthermore, correct firing is essential to a locomotive hauling full tonnage and being worked to full capacity, and a good fireman can be depended on to take 10 to 15 per cent more tons over a division than a poor one.

Correct firing was a hobby of the late C. W. Hayes, superintendent locomotive operation of the Erie Railroad, and while this was pretty generally known, I doubt if the results he obtained from riding this hobby were as well known. From what I saw of the locomotives under his supervision, and from what I learned regarding them from experts in my employ, I formed the opinion that the average of the firing done on them was better than any other I know anything about. As a result of the careful and persistent following up which Mr. Hayes gave this subject, I know that these locomotives were worked more nearly to their full capacity than is usual with hand firing, and I have every reason to believe they were burning less coal in relation to the work done. I have looked in the fireboxes of many locomotives on that road and found many fires which showed clearly that the fireman had been doing a good job. On the other hand I have looked in the fireboxes of locomotives on other roads, some of the officials of which roads were in the habit of using their most patronizing tone of voice when

speaking of "The Poor Old Erie," and have found many of them so full of coal and ashes that they would fall out of the fire door when it was opened.

There is probably no other line of work of equal importance where men have the proposition put up to them with as little instruction and preparation as they have when they tackle the job of firing a locomotive, and I doubt if there is any other place on a railroad where more effectual safeguards can be erected against possible waste than can be done by a well organized force of firemen instructors.

SUMMARY

The railroads of this country have for several years past been showing an increase in net earnings in the face of reductions in rates and increases in operating expenses, and they have been doing this with a regularity and to an extent which has resulted in the belief in many minds that the rates which they have been receiving were too high, and should be even further reduced. If the foregoing statements of what has been, and is being done, are given careful consideration, it will be seen that the good showings which have been made, are the result of the outlay of large sums of money in a carefully analyzed system of improvements for increasing efficiency. The railroads have been buying locomotives of the greatest hauling capacity ever known, and also the most efficient in operation. They have also been furnishing better engine house supervision, increasing locomotive mileage, reducing train delays, using better coal, and giving better supervision to the burning of coal. This is not the entire list by any means, but as a result of these and other things, all with the same object in view, the railroads of the United States have been for many years and are to-day, hauling a ton of freight one mile at a less cost than it ever has been or is being done in any other country in the world, and are carrying passengers at a less cost and in greater comfort than they think of expecting elsewhere.

WATCH THE HIGH WATER MAN

Some locomotive engineers seem possessed to carry the water too high in the boiler. It is a practice that wastes coal and interferes with the proper performance of the locomotive. High water restricts the steam space and gives the steam a much too high degree of priming. It is particularly objectionable on superheater locomotives. If the water level is kept at such a point that water is carried over through the throttle and dry pipe into the superheater, the latter has to turn this water into steam, thus giving up part of its surface for evaporative purposes, and there is a consequent reduction in the amount of superheat obtained and a falling off in the locomotive's performance. The superheater is placed in a locomotive for the purpose of superheating steam, not for evaporating water. The so-called "high water man" should be carefully watched and instructed in carrying the water level at a point as low as possible, consistent with safety. This is a point which should be the subject of constant care and attention on the part of the enginemen and road foremen. If given the attention it deserves, it will bring results which will pay for the time and energy taken to watch it.

PENNSYLVANIA HOLDS FAST TRAIN FOR SICK WATCHMAN.—The Pennsylvania Railroad company showed the human side of the corporation one morning recently when it held up one of its through passenger trains, running as an extra with first class privileges, for half an hour to get a doctor on board who would carry relief to a lone watchman in a little box six miles west of Lewistown Junction, Pa., suffering from an acute attack of cramps. After the doctor had administered first aid to the sick watchman, both were brought to a local hospital in the caboose of a freight train.

IMPROVED APPRENTICESHIP METHODS ON THE PENNSYLVANIA

BY J. H. YODER
SUPERVISOR
OF
APPRENTICES

THE OCCUPATIONS of machinist, boilermaker, blacksmith, etc., which require a high degree of mechanical skill and are necessary in time of peace, become a national asset in time of war. The importance of railway workers trained in these trades, during periods of national emergency, has been demonstrated during the past few months. A statement has been issued by the national government calling attention to the necessity of developing a body of highly trained industrial workers, so that the war may be pushed to a successful conclusion. It is, therefore, imperative that those in charge of training mechanics do not grow lax in their efforts and that the number of apprentices learning trades be kept to the highest possible point consistent with the shop efficiency.

Owing to the scarcity of skilled men at this time there is ample opportunity to place the more advanced apprentices on productive work. This will help the apprentice to develop confidence in himself, and in the meantime increase shop output. Present conditions again demonstrate the lack of a sufficient number of thoroughly trained mechanics.

It is unfortunate that it takes times like the present to wake us up to the fact that skilled men are an absolute necessity. Those concerns which have well-established apprenticeship systems have not fared as badly as those which are not so fortunate. However, it is also a fact with those concerns

that have a well-established system that apprentices have not always been hired with a definite degree of regularity. In order that apprenticeship be successful and supply the ever-increasing needs for skilled men it is imperative that

a definite minimum number of apprentices be hired every month, irrespective of industrial conditions for the time being. In many cases where too few apprentices were hired in the past the result was that at times like the present an insufficient number of graduates are forthcoming.

Much has already been written about apprenticeship but present conditions, due to the war, demand with increasing importance that the mechanical department of the railroad have a well-established apprenticeship system which provides:

First—The training of competent skilled and intelligent mechanics.

Second—The training of men for minor executive positions.

Third—The training of men, who are college graduates, for executive positions requiring an engineering education.

Fourth—School instruction co-incident with the work be-

THE PENNSYLVANIA Railroad has always given much attention to the training of its employees in the mechanical department. There has possibly been, however, too great an emphasis placed on the training of college men for the more important positions and too large a gap between the regular and the special apprentices. Mr. Yoder sketches the latest developments in the apprenticeship course from which it appears that this gap has been filled and that it is now possible for the regular apprentice to go as high as his abilities and energy will permit. Indeed, regular apprentices are encouraged to qualify for the more important positions.

The wisdom of modern apprenticeship methods advocated by such men as Basford, Cross and Thomas is being emphasized in the present emergency and it is to be hoped that the railroads will awaken to the absolute necessity of adopting such methods.

ing done by the apprentices in the shop.

With the above objects in view, there are established on the Pennsylvania Railroad three grades of apprentices; namely, *Regular*, *First-class* and *Special*. The regular apprentices comprise the major part of the apprentices em-

ployed. These graduate as mechanics and are given employment in the shops and engine houses. It is toward this class that the main effort is directed. The training is such as to embody every phase of shop work encountered in building or repairing railway equipment. At the end of the

condition makes it imperative that the standard of the other grades be raised to fill this gap. It is encouraging to note too that the first-class apprentices are being used in many cases where special apprentices were formerly employed.

APPRENTICE SCHOOL

Perhaps no other factor has had a greater influence in improving the apprenticeship system than the establishment, by the company, of its apprentice schools. An experimental school was established in February, 1910, by having two instructors from the Pennsylvania State College conduct a class consisting of thirty selected apprentices. This class met twice a week for two hours each period and proved to be such a success that in the following September two instructors were employed by the company and placed on the rolls of the superintendent of motive power, Eastern Pennsylvania division.

The enrollment at the beginning of the first school year was 180 while in July of the following year this number had increased to 277. The development has since been rapid and within the last two years the instruction system has been extended to include all shops on the Lines East. There are now eleven schools, and apprentices at all shops receive practically the same training. The largest school is at Altoona, where 235 apprentices are now enrolled. In these schools apprentices are given a thorough training in the underlying physical and mathematical principles of their respective trades. The object is to give regular and first-class apprentices the benefit of education and thereby make them of more value to themselves and more efficient workmen.

The subjects taught unfold reasons for things done in the shops, the school and shop work being closely coordinated. Problems are given which require shop experience to be answered intelligently. In this way habits of observation are early acquired and the apprentice learns to analyze difficult situations and arrive at a proper solution of his problems. In addition a thorough grounding in practical mathematics and mechanics is included in the school course. The problems given are practical, and whenever possible are made



Third Year Apprentice Turning Tires in the Wheel Shop

four-year training they are highly skilled mechanics and can follow successfully any one of a number of activities.

First-class apprentices are appointed from regular apprentices after serving three years. They win this recognition through diligent application in both the shops and school and after having demonstrated their fitness to be advanced to the highest standing. Apprentices from all shops have opportunity to become first-class apprentices. If appointed to this advanced standing they must be transferred to Altoona, since all first-class apprentices are trained at these shops. The schedule embodies a wide range of all phases of railroad work which fits the first-class apprentice to occupy positions of minor responsibility and leadership upon the completion of his course. Many are appointed to important positions after proving themselves worthy and competent, and are in line for further advancement. *As a prize to the best and most capable, one first-class apprentice each year is advanced to the grade of motive power inspector and placed on the same standing as graduate special apprentices.* This means that if those so appointed continue to develop, they will be in line for promotion to the higher positions the same as graduate special apprentices.

Special apprentices are graduates of recognized technical colleges or universities who serve three years at the Altoona shops. The greater part of the time is devoted to intensive training in all phases of shop work, including car building and repairing, enginehouse work, and locomotive firing. The aim is not to develop skill and mechanical dexterity, but to give a general insight into shop conditions, locomotive operation, etc., so that as higher officials these men will be able to make judicious decisions on important work that may come before them as executives. It is unfortunate though that there are so few special apprentices at this time due to the unprecedented demand for college trained men. This



Third Year Apprentice Working in Link Gang

to apply to some phase of work which may come under the immediate observation of the apprentice. The texts used are especially adapted for instruction in Pennsylvania Railroad standards and methods. The instruction given covers

problems dealing with locomotives, cars, machine tools, screw jacks, blocks and tackle, thread cutting, gears, belts and pulleys, cutting speeds of tools, etc.

The apprentices who are more proficient and advanced in their studies are given courses in locomotive valves and valve gears, valve setting, materials of construction, strength of materials, locomotive boiler construction and operation, and in many cases applied elementary electricity. This work is arranged so that apprentices who have had a good schooling and those with initiative can advance to the higher sections early in their apprenticeship, and thereby obtain more of the advanced subjects and have greater opportunities to earn recognition as first-class apprentices. With this course of instruction apprentices become familiar with the underlying principles of their trade and receive the mental training to develop right methods of thinking. The apprentice school is making it possible for graduate first-class apprentices to be used to good advantage where formerly only special ap-

proper lines. Standardized shop schedules are furnished to shop officials for guidance in training apprentices in the various trades, so that all apprentices, no matter where they serve their time, will receive practically the same training. As an aid in a closer supervision of the work pertaining to apprentices, all shop schedules, together with rules and regulations, etc., have been issued by the general superintendent of motive power in the form of standard instructions No. A-1, "Organization and Rules Governing Employment and Training of Apprentices." These instructions tell definitely what each apprentice is to receive, while at the same time they set forth in a concise way what is expected of the individual apprentice.

With the new organization for training apprentices in both the school and the shop, boys entering the shops to learn a trade no longer find themselves part of a vast organization in which they have that feeling of being lost. They are being respected by the shop officials and the men employed and



Advanced Section Receiving Instructions in Mechanical Drawing, Shop Sketching, etc.

prentices were employed. It also enables graduate regular apprentices to qualify for important positions in time to come.

SHOP FOREMAN OF APPRENTICES

The successful operation of any apprentice system depends on the apprentice being given the right kind of instruction in the shop. In order to see that apprentices follow definite shop schedules and are given the right kind of work, the position of shop foreman of apprentices was established. This official is responsible for the proper observance of the shop schedules. He reports to the supervisor of apprentices, co-operates with the shop officials and sees that the proper instruction is given apprentices in the shop. He assists in placing the apprentice, after graduation, on work suitable to his ability. At Altoona shops he is assisted by the shop instructor. Many difficulties which the new boy assigned to a machine meets with are thus smoothed out and the output is kept at the highest point from the very beginning. The work of these men has increased materially the general interest and enthusiasm of the apprentice during the short time the plan has been in operation.

Since the establishment of the apprentice schools and closer supervision of the shop work, a decided increase in the interest toward apprenticeship has been shown by the shop officials and the men in the shop. Instead of apprentices being left to drift aimlessly about the shop and pick up a trade as best they can, their energies are now directed along

find all amiable and ready to assist them in every way possible. From the fact that apprentices are followed closely in their work, they early realize the advantages of putting forth their best efforts. With the added advantages of winning promotion from regular apprentices to first class, and from first-class apprentices to that of motive power inspector, there is increased incentive to strive for advanced standing. At the same time regular apprentices who have later developed exceptional ability along special lines have been placed in important positions, so that the new apprentice sees a definite future ahead and apprenticeship has become more attractive. As a whole an apprentice finds his four years spent in the shops a source of pleasure, and in years to come will look back to his apprenticeship with a great amount of pride. Apprenticeship has been the making of many a man, and, since the advent of the apprentice school and special shop supervision and instruction, it is believed that, next to a college education, it is the best preparation for a life vocation.

[Mr. Yoder's mention of the co-operation received from Pennsylvania State College is of special interest in conjunction with the article by Professor Arthur J. Wood of that institution, which will be found elsewhere in this issue. Active co-operation of this sort between our railroads and the colleges and universities is to be commended. A most remarkable demonstration of what can be done in this way is the work done by the co-operative engineering courses of the University of Cincinnati under the direction of Dean Schneider. —Editor.]

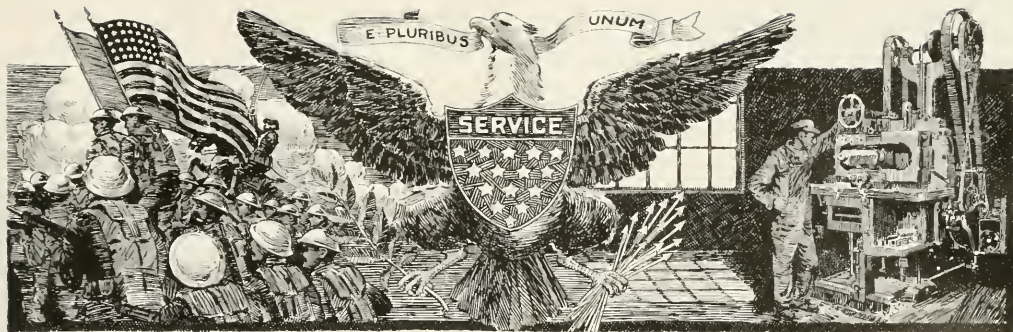

THE RAILROAD "ROLL OF HONOR"

Seventy Thousand Men Have Entered Government Service—20,000 From the Mechanical Department

NEARLY five per cent of all the employees of the railroads in the United States are now in some branch of the army or navy, according to information furnished by the carriers, in answer to inquiries made by the Railway Age. Replies were received from 118 railroads, operating a total of 200,744 miles of line, or about 77 per cent of the entire mileage of the country.

These roads reported that 54,375 officers and employees had left their service since the declaration of war to join the military or naval forces of the United States. If the number of men which the remaining railroads of the country have furnished to the government bears the same relation to their mileage as for the roads from which reports were received, the total number of railway men in army and navy is approximately 70,000 or nearly five per cent of all the employees. About 1,800 railroad men have received commissions as officers. More than one-fourth of the total number of men in government service are former employees of the mechanical department. The total number of men from the mechanical department is probably about 20,000.

Railroad men have been called on by the government for special service as have no other classes. Soon after the declaration of war nine railway regiments were organized for service on the roads supplying the American forces in France. Two additional regiments, the 21st Engineers, for light railway construction, and the 35th Engineers, a shop regiment, have been organized at Camp Grant, Rockford, Ill., during the past three months. Still another special military organization recruited from the ranks of the railway employees is the Russian Railway

Corps, consisting of 200 officers chosen from the railroads of the Northwest which sailed for Russia this fall, where they were expected to engage in the rehabilitation of the Trans-Siberian railway.

The organization of the railway regiments for service in France and also the Russian

Railway Corps, was carried on under the direction of S. M. Felton, president of the Chicago Great Western, who is now director general of railroads, with headquarters at Washington. The men chosen for the heads of both these organizations are former officers of the mechanical department.

The highest commission accorded to any railroad man in the government service is held by W. W. Atterbury, vice president of the Pennsylvania Railroad, now Brigadier-General and Director General of American Railways in France. Gen. Atterbury entered railway service in 1886 as an apprentice in the Altoona shops of the Pennsylvania Railroad. He rose to the position of general superintendent of motive power in 1901, was made general manager in 1903 and in 1909 became vice president. Prior to his appointment as the director of the American railways in France, Gen. Atterbury had been active in the work of recruiting the first nine railway regiments.

H. H. Maxfield, superintendent of motive power of the Western Pennsylvania division of the Pennsylvania Railroad, is a lieutenant-colonel with the American Railway forces in France. In addition to these officers, the mechanical department of this road has furnished the military forces of the United States 2 majors and 13 captains.

The railroads of this country have without exception will-

THE AMERICAN RAILROADS may justly feel proud of their record since this country entered the war. Even with the enormous burden placed upon them since war was declared, the carriers have not asked for exemption for their employees, except in special cases, and have performed splendid service for the government. The remarkable work of the engineer regiments recruited from the railroads, is known to all who have read the despatches from the front. It is not unreasonable to expect that many of the railroad men in other branches of the service will make equally brilliant records. Their fellow employees who are left to do their part in winning the war at their regular posts will follow the activities of their companions across the seas with keen interest. The list of mechanical department men who have received commissions, given in the accompanying article, will, therefore, be of special interest.

ingly furnished their full quota of men to the government. Some of the large railroad systems have not been able to furnish statistics showing the number of employees in the government service. The list below gives as complete data as it was possible to secure concerning the men from the mechanical department of the railroads of this country who have received commissions as officers and also the total number of men from all departments who have joined the colors.

Arizona Eastern

MECHANICAL DEPARTMENT EMPLOYEES WHO RECEIVED COMMISSIONS				
Name	Railroad Position	Military Rank	Branch of Service	
Worcester, H. W.	Draftsman	1st Lieut.		
Employees who received commissions..... 8				
Total number of employees in government service..... 87				

Achison, Topeka & Santa Fe

MECHANICAL DEPARTMENT EMPLOYEES WHO RECEIVED COMMISSIONS				
Name	Railroad Position	Military Rank	Branch of Service	
Chapman, E. A.	Asst. Engr. Tests.	Captain	Ord. Dept.	
Grover, C. A.	Mech. Insp.	Captain	Depot Brigade	
Jackson, J. R.	Asst. Engr. Tests.	Captain	Ord. Dept.	
Peck, H. M.	Machinist	Captain	Infantry	
Schuster, G.	Asst. Engr. Tests.	Captain	Ord. Dept.	
Bohnstengel, Walter.	Asst. Engr. Tests.	1st Lieut.	Ord. Dept.	
Hill, W. J.	Master Mechanic.	1st Lieut.	Ry. Engrs.	
Miller, H. R.	Mach. Helper	1st Lieut.	National Guard	
Reed, D. R.	Material Insp.	1st Lieut.	Ord. Dept.	
Robinson, A. W.	Asst. Test Dept.	1st Lieut.	Ord. Dept.	
Richter, J. P.	Asst. Test Dept.	1st Lieut.	Aviation Corps	
Sanders, E. C.	Test Dept.	1st Lieut.	Ord. Dept.	
Van Blucher, L. F.	R. H. Foreman.	1st Lieut.	Ry. Engrs.	
Wheeler, G. O.	Fireman	1st Lieut.	Aviation Corps	
Employees who received commissions..... 97				
Total number of employees in government service..... 3,000				

Atlantic Coast Line

MECHANICAL DEPARTMENT EMPLOYEES WHO RECEIVED COMMISSIONS				
Name	Railroad Position	Military Rank	Branch of Service	
Mapother, Jr., H. H.	Inspector	2nd Lieut.	305th Engrs.	
Sanders, W. C.	Draftsman	2nd Lieut.	C. A. C.	
Employees who received commissions..... 37				
Total number of employees in government service..... 760				

Baltimore & Ohio

MECHANICAL DEPARTMENT EMPLOYEES WHO RECEIVED COMMISSIONS				
Name	Railroad Position	Military Rank	Branch of Service	
McDonough, J. J.	Asst. Supt. Shops.	Captain	E. O. R. C.	
Gaither, H. B.	Gen. Fc. Wk. Insp.	1st Lieut.	Engr. R. C.	
McGuire, J. J.	Master Mechanic.	2nd Lieut.	Engr. Corps	
Mellon, F. C.	Inspector	2nd Lieut.	Infantry	
Offutt, R. J.	Machinist	2nd Lieut.	Engr. Corps	
Employees who received commissions..... 69				
Total number of employees in government service..... 1,760				

Bangor & Aroostook

Total number of employees in government service..... 75

Bessemer & Lake Erie

Total number of employees in government service..... 222

Boston & Albany

MECHANICAL DEPARTMENT EMPLOYEES WHO RECEIVED COMMISSIONS				
Name	Railroad Position	Military Rank	Branch of Service	
Smith, E. H.	Master Mechanic.	1st Lieut.	Ry. Engrs.	
Employees who received commissions..... 6				
Total number of employees in government service..... 295				

Boston & Maine

MECHANICAL DEPARTMENT EMPLOYEES WHO RECEIVED COMMISSIONS				
Name	Railroad Position	Military Rank	Branch of Service	
Bradley, Ralph.	Insp. Fuel Serv.	Captain	14th Engrs.	
Employees who received commissions..... 18				
Total number of employees in government service..... 1,201				

Buffalo, Rochester & Pittsburgh

Employees who received commissions..... 3

Total number of employees in government service..... 370

Central of Georgia

Total number of employees in government service..... 341

Central of New Jersey

Employees who received commissions..... 5

Total number of employees in government service..... 652

Central Vermont

MECHANICAL DEPARTMENT EMPLOYEES WHO RECEIVED COMMISSIONS				
Name	Railroad Position	Military Rank	Branch of Service	
Lampman, L. H.	Machinist	1st Lieut.	Infantry	
Employees who received commissions..... 6				
Total number of employees in government service..... 70				

Chesapeake & Ohio

MECHANICAL DEPARTMENT EMPLOYEES WHO RECEIVED COMMISSIONS				
Name	Railroad Position	Military Rank	Branch of Service	
Bills, A. C.	Machinist	2nd Lieut.		
Employees who received commissions..... 23				
Total number of employees in government service..... 575				

Chicago & Alton

MECHANICAL DEPARTMENT EMPLOYEES WHO RECEIVED COMMISSIONS				
Name	Railroad Position	Military Rank	Branch of Service	
Helwig, A. A.	Trav. Car. For.	1st Lieut.	Engrs. Corps	
Employees who received commissions..... 12				
Total number of employees in government service..... 195				

Chicago & Eastern Illinois

Employees who received commissions..... 7

Total number of employees in government service..... 274

Chicago & North Western

MECHANICAL DEPARTMENT EMPLOYEES WHO RECEIVED COMMISSIONS				
Name	Railroad Position	Military Rank	Branch of Service	
Brandt, J. E.	Rd. For. of Ebr.	Colonel	126th F. A.	
Jensen, G. B.	Fireman	Captain	Truck Co.	
Luth, F. L.	Trav. Car. For.	Captain	126th F. A.	
McMahan, Ray.	Fireman	Captain	Field Artillery	
La Bru, H.	R. H. For.	1st Lieut.	Russ. Ry. Corps	
Lowry, F. H.	Traveling Engr.	1st Lieut.	Russ. Ry. Corps	
Miller, F. C.	Trav. Car. For.	1st Lieut.	Russ. Ry. Corps	
Sanborn, J.	Engr.	1st Lieut.	108th Engrs.	
Schultz, E.	Master Mechanic.	1st Lieut.	Ry. Engrs.	
Cooley, E. M.	Engr.	2nd Lieut.	Nat'l Guard	
Holt, W. A.	Foreman	2nd Lieut.	Russ. Ry. Corps	
James, W. H.	R. H. For.	2nd Lieut.	Russ. Ry. Corps	
Stewart, E. L.	Inspector	2nd Lieut.	Russ. Ry. Corps	
Employees who received commissions..... 47				
Total number of employees in government service..... 1,573				

Chicago, Burlington & Quincy

MECHANICAL DEPARTMENT EMPLOYEES WHO RECEIVED COMMISSIONS				
Name	Railroad Position	Military Rank	Branch of Service	
Climo, J. C.	Master Mechanic.	Captain	Russ. Ry. Corps	
Roach, J. B.	Master Mechanic.	Captain	Russ. Ry. Corps	
Woody, A. E.	Test Car. For.	Captain	Ord. Dept.	
Law, George	Safety Insp.	1st Lieut.	Russ. Ry. Corps	
Swartzcoe, F. W.	R. H. For.	2nd Lieut.	Russ. Ry. Corps	
Waldhaus, A. S.	Engr.	2nd Lieut.	Russ. Ry. Corps	
Employees who received commissions..... 32				
Total number of employees in government service..... 1,486				

Chicago Great Western

MECHANICAL DEPARTMENT EMPLOYEES WHO RECEIVED COMMISSIONS				
Name	Railroad Position	Military Rank	Branch of Service	
Brunner, E. F.	Machinist	2nd Lieut.	Russ. Ry. Corps	
Jones, A. E.	R. H. Foreman.	2nd Lieut.	Russ. Ry. Corps	
Employees who received commissions..... 12				
Total number of employees in government service..... 306				

Chicago, Indianapolis & Louisville

Employees who received commissions..... 4

Total number of employees in government service..... 123

Chicago, Milwaukee & St. Paul

MECHANICAL DEPARTMENT EMPLOYEES WHO RECEIVED COMMISSIONS				
Name	Railroad Position	Military Rank	Branch of Service	
Buchanan, F.	Trav. Engr.	Captain	Russ. Ry. Corps	
Young, A.	Master Mechanic.	Captain	Ry. Engrs.	
Lusk, George.	Engr.	Lieut.	Russ. Ry. Corps	
Merz, A. S.	Engr.	Lieut.	Russ. Ry. Corps	
Employees who received commissions..... 34				
Total number of employees in government service..... 1,645				

Chicago, Rock Island & Pacific

MECHANICAL DEPARTMENT EMPLOYEES WHO RECEIVED COMMISSIONS				
Name	Railroad Position	Military Rank	Branch of Service	
Eck, P.	Boiler For.	1st Lieut.	Russ. Ry. Corps	
Mueller, R.	Foreman	1st Lieut.	Engrs. Corps	
Phelan, T. F.	Rd. For. Equip.	1st Lieut.	Russ. Ry. Corps	
Reed, C. W.	Rd. For. Equip.	1st Lieut.	Ry. Engineers	
Schlemmer, H.	Loco. Engr.	1st Lieut.	National Army	
Jones, J. R.	Engr.	2nd Lieut.	Russ. Ry. Corps	
Roberts, J. G.	Fuel Inspector.	2nd Lieut.	National Army	
Tatum, H.	Gen. For.	2nd Lieut.	Russ. Ry. Corps	
Employees who received commissions..... 26				
Total number of employees in government service..... 1,457				

Chicago, St. Paul, Minneapolis & Omaha

MECHANICAL DEPARTMENT EMPLOYEES WHO RECEIVED COMMISSIONS				
Name	Railroad Position	Military Rank	Branch of Service	
Burton, W. Y.	Shst. For.	Lieut. Col.	Infantry	
Enockson, H. A.	R. H. Foreman.	Captain	Russ. Ry. Corps	
Lystad, A.	Timber	Captain	Infantry	
Bronson, H. S.	Draftsman	Lieut.	E. O. R. C.	
Copeland, Peter.	Engr.	Lieut.	Russ. Ry. Corps	
Kuhfeld, W. G.	R. H. Foreman	Lieut.	National Army	
Larson, Chas.	Trav. Engr.	Lieut.	Russ. Ry. Corps	
Lyksett, A. J.	Painter	Lieut.	Infantry	
Mathews, J. V.	Asst. B. M. For.	Lieut.	Russ. Ry. Corps	
Mattison, C. J.	Loco. Engr.	Lieut.	Russ. Ry. Corps	
Peters, E. S.	Asst. B. M. For.	Lieut.	Russ. Ry. Corps	
Sorenson, C. H.	Machinist	Lieut.	Russ. Ry. Corps	
Van Dresser, M. S.	Boilermaker	Lieut.	Russ. Ry. Corps	
Employees who received commissions..... 32				
Total number of employees in government service..... 371				

Cincinnati, Indianapolis & Western

Employees who received commissions.....	1
Total number of employees in government service.....	52

Cincinnati Northern

MECHANICAL DEPARTMENT EMPLOYEES WHO RECEIVED COMMISSIONS

Name	Railroad Position	Military Rank	Branch of Service
Berthold, A.....	Roundhouse Man.	1st Lieut.	
Employees who received commissions.....			1
Total number of employees in government service.....			30

Cleveland, Cincinnati, Chicago & St. Louis

Employees who received commissions.....	9
Total number of employees in government service.....	699

Colorado & Southern

Employees who received commissions.....	2
Total number of employees in government service.....	83

Cumberland Valley

Employees who received commissions.....	5
Total number of employees in government service.....	70

Delaware & Hudson

Employees who received commissions.....	10
Total number of employees in government service.....	454

Delaware, Lackawanna & Western

Employees who received commissions.....	2
Total number of employees in government service.....	88

Denver & Rio Grande

Total number of employees in government service.....	249
--	-----

Elgin, Joliet & Eastern

Total number of employees in government service.....	319
--	-----

El Paso & Southwestern

Employees who received commissions.....	4
Total number of employees in government service.....	151

Erie

MECHANICAL DEPARTMENT EMPLOYEES WHO RECEIVED COMMISSIONS

Name	Railroad Position	Military Rank	Branch of Service
Thorpe, John.....	Engr. Tests	Captain	Aviation Corps
Employees who received commissions.....			26
Total number of employees in government service.....			1,375

Great Northern

MECHANICAL DEPARTMENT EMPLOYEES WHO RECEIVED COMMISSIONS

Name	Railroad Position	Military Rank	Branch of Service
Emerson, G. H.....	Gen. Mgr.	Colonel	Russ. Ry. Corps
Hawkins, R. B.....	Supt. of M. P.	Lieut. Colonel	Russ. Ry. Corps
Benson, J. C.....	Mast. Mech.	Captain	Russ. Ry. Corps
Boynton, Robert.....	Draftsman	2nd Lieut.	Infantry
Kellerman, R. C.....	Draftsman	2nd Lieut.	Q. M. Corps
Upton, Wm. B.....	Inspector	2nd Lieut.	U. S. R. Corps
Employees who received commissions.....			23

Gulf, Mobile & Northern

Total number of employees in government service.....	67
--	----

Illinois Central

MECHANICAL DEPARTMENT EMPLOYEES WHO RECEIVED COMMISSIONS

Name	Railroad Position	Military Rank	Branch of Service
Nash, F. P.....	Gen. Foreman	1st Lieut.	Ry. Engrs.
Donker, J. E.....	Car Repairer	2nd Lieut.	
Hutton, J. A.....	Engine For.	2nd Lieut.	
Kern, J. W., Jr.....	Gen. Foreman	2nd Lieut.	
Employees who received commissions.....			57
Total number of employees in government service.....			1,916

International & Great Northern

MECHANICAL DEPARTMENT EMPLOYEES WHO RECEIVED COMMISSIONS

Name	Railroad Position	Military Rank	Branch of Service
Flemer, H.....	Draftsman	1st Lieut.	
Employees who received commissions.....			9
Total number of employees in government service.....			162

Kansas City Southern

Total number of employees in government service.....	135
--	-----

Lake Erie & Western

Employees who received commissions.....	4
Total number of employees in government service.....	133

Long Island

MECHANICAL DEPARTMENT EMPLOYEES WHO RECEIVED COMMISSIONS

Name	Railroad Position	Military Rank	Branch of Service
Foster, F. H.....	Gen. Foreman	Captain	National Army
Mack, J. W.....	Supt. of M. P.	1st Lieut.	Navy
Best, H. S.....	Gen. Foreman	Captain	National Army
Dempsey, J. M.....	Draftsman	1st Lieut.	Navy
Kiely, E. J., Jr.....	Elec. Inspector	1st Lieut.	Natl Army
Employees who received commissions.....			7
Total number of employees in government service.....			279

Los Angeles & Salt Lake

Employees who received commissions.....	8
Total number of employees in government service.....	116

Louisiana Railway & Navigation Company

Total number of employees in government service.....	60
--	----

Louisville & Nashville

MECHANICAL DEPARTMENT EMPLOYEES WHO RECEIVED COMMISSIONS

Name	Railroad Position	Military Rank	Branch of Service
Finley, G. S.....	Machinist	2nd Lieut.	
Employees who received commissions.....			30
Total number of employees in government service.....			1,410

Maine Central

MECHANICAL DEPARTMENT EMPLOYEES WHO RECEIVED COMMISSIONS

Name	Railroad Position	Military Rank	Branch of Service
Sturgeon, R.....	Loco. Engr.	1st Lieut.	Engr. Corps
Employees who received commissions.....			10
Total number of employees in government service.....			252

Michigan Central

Employees who received commissions.....	6
Total number of employees in government service.....	551

Minneapolis & St. Louis

MECHANICAL DEPARTMENT EMPLOYEES WHO RECEIVED COMMISSIONS

Name	Railroad Position	Military Rank	Branch of Service
Rogers, C. B.....	R'd Fm. of Eng.	Lieut.	Russ. Ry. Corps

Minneapolis, St. Paul & Sault Ste. Marie

MECHANICAL DEPARTMENT EMPLOYEES WHO RECEIVED COMMISSIONS

Name	Railroad Position	Military Rank	Branch of Service
Casey, J.....	Master Mechanic	Captain	
Roberts, F. M.....	Trav. Engr.	1st Lieut.	
Baers, C. A.....	R. H. For.	2nd Lieut.	
Greeneth, A. G.....	R. H. For.	2nd Lieut.	
Patton, P. S.....	Machinist	2nd Lieut.	
Praiss, W. C.....	Engineer	2nd Lieut.	
Employees who received commissions.....			14
Total number of employees in government service.....			474

Missouri, Kansas & Texas

Employees who received commissions.....	4
Total number of employees in government service.....	80

Mobile & Ohio

Employees who received commissions.....	10
Total number of employees in government service.....	150

Nashville, Chattanooga & St. Louis

MECHANICAL DEPARTMENT EMPLOYEES WHO RECEIVED COMMISSIONS

Name	Railroad Position	Military Rank	Branch of Service
Law, A. J.....	Master Mechanic	Captain	O. R. C.

New York Central

Employees who received commissions.....	6
Total number of employees in government service.....	4,978

New York, Chicago & St. Louis

Employees who received commissions.....	5
Total number of employees in government service.....	176

New York, New Haven & Hartford

MECHANICAL DEPARTMENT EMPLOYEES WHO RECEIVED COMMISSIONS

Name	Railroad Position	Military Rank	Branch of Service
Kearny, P. J.....	Elec. Engr.	Captain	Ordnance Dept.
Cole, A. B.....	Inspector	1st Lieut.	Army
Burr, C. M.....	Road Foreman	2nd Lieut.	
Fleming, J.....	Asst. For. Shops	2nd Lieut.	14th Engrs.
Employees who received commissions.....			26
Total number of employees in government service.....			1,446

New York, Ontario & Western

Employees who received commissions.....	2
Total number of employees in government service.....	128

Norfolk & Western

MECHANICAL DEPARTMENT EMPLOYEES WHO RECEIVED COMMISSIONS

Name	Railroad Position	Military Rank	Branch of Service
Davant, E. T.....	Elec. Engr.	Captain	Infantry
Lewis, F. B.....	Engr. Tests	Captain	Artillery
White, G. J.....	Furnace Rm.	Captain	Infantry
Bohwell, W.....	Foreman	1st Lieut.	35th Engrs.
Joines, M.....	Engineer	2nd Lieut.	Cavalry
Employees who received commissions.....			49
Total number of employees in government service.....			865

Northern Pacific

MECHANICAL DEPARTMENT EMPLOYEES WHO RECEIVED COMMISSIONS

Name	Railroad Position	Military Rank	Branch of Service
Egbers, G. F.....	M. M.	Captain	Russ. Ry. Corps
King, B. C.....	Boiler Foreman	1st Lieut.	Russ. Ry. Corps
Montgomery, M. S.....	Traveling Engr.	1st Lieut.	Russ. Ry. Corps
Brown, J. J.....	Machinist	2nd Lieut.	Russ. Ry. Corps
Hazzard, G. H.....	R. H. Foreman	2nd Lieut.	Russ. Ry. Corps
Nakern, F. M.....	R. H. Foreman	2nd Lieut.	Russ. Ry. Corps

Name	Railroad Position	Military Rank	Branch of Service
Panton, L. A.	R. H. Foreman	2nd Lieut.	Russ. Ry. Corps
Terry, C. L.	Machinist	2nd Lieut.	Russ. Ry. Corps
Vickers, F.	Machinist	2nd Lieut.	Russ. Ry. Corps
Employees who received commissions..... 61			
Total number of employees in government service..... 1,638			

Northwestern Pacific

Employees who received commissions.....	3
Total number of employees in government service.....	56

Oregon Short Line

Employees who received commissions.....	9
Total number of employees in government service.....	474

Oregon, Washington R. R. & Navigation Co.

Name	Railroad Position	Military Rank	Branch of Service
Hess, A. E.	Car Rep.	Helper, 1st Lieut.	
Employees who received commissions..... 17			
Total number of employees in government service..... 294			

Pennsylvania System

LINE WEST OF PITTSBURGH.

Name	Railroad Position	Military Rank	Branch of Service
Haubrick, R.	Machinist	Captain	Infantry
Brandt, O. H.	Foreman	1st Lieut.	Infantry
Mercer, J. B.	Mach. Helper	1st Lieut.	10th Ohio
Munro, H. H.	Clerk	1st Lieut.	Synk. Corps
Wood, L. F.	Frat. Engineman	1st Lieut.	Field Artillery
Bridges, P. E.	Repairman	2nd Lieut.	Machine Gun Co.
Minick, D. C.	Gang Foreman	2nd Lieut.	19th Engrs.
Total number of employees in government service..... 3,229			

PENNSYLVANIA RAILROAD

Name	Railroad Position	Military Rank	Branch of Service
Atterbury, W. W.	Vice-Pres.	Brigadier Gen.	D-G. Engrs. F.
Maxfield, H. H.	Asst. Insp.	Power Lieut. Col.	19th Ry. Engrs.
Barrett, C. D.	Master Mech.	Major	19th Ry. Engrs.
Gaskill, C. S.	Master Mech.	Major	19th Ry. Engrs.
Byron, A. W.	Master Mech.	Captain	Off. Dir. Gen. Ry.
Dunkel, J. R.	B. M. Helper	Captain	Infantry
Harris, R. H.	Car Repairman	Captain	Cavalry
Hatfield, C. H.	Car Repairman	Captain	Infantry
Huff, G. F.	Asst. Rd. F. of En.	Captain	19th Ry. Engrs.
Klone, B. W.	Electrician	Captain	19th Ry. Engrs.
Lindner, W. C.	Gen. Forman	Captain	35th Ry. Engrs.
MacKendrick, R. G.	Draftsman	Captain	108th U. S. F. A.
Moore, J. F.	Fireman	Captain	101st U. S. Cav.
Reynolds, R. H.	Power Plant Engr.	Captain	Infantry
Robbins, F. S.	Asst. Mast. Mech.	Captain	19th Ry. Engrs.
Roberts, C. H.	Asst. F. of E.	Captain	21st Ry. Engrs.
Salter, D. M.	Shop Hand	Captain	110th M. G. Bat.
Smith, R. M.	Asst. R. F. of E.	Captain	35th Ry. Engrs.
Whitman, E. B.	Asst. R. F. of E.	Captain	19th Ry. Engrs.
Darr, P. W.	Inspector	1st Lieut.	Ord. Dept.
Boffenmeyer, C. G.	Inspector	1st Lieut.	19th Ry. Engrs.
Diekson, Jr., O. S.	Chief Inspector	1st Lieut.	35th Ry. Engrs.
Diehl, J. C.	Safety Draftsman	1st Lieut.	Engrs. O. R. C.
Riesel, J. H.	Inspector	1st Lieut.	21st Ry. Engrs.
Maitan, T. M.	Foreman	1st Lieut.	19th Ry. Engrs.
Morris, J. M.	Asst. Mast. Mech.	1st Lieut.	21st Ry. Engrs.
Richers, G. L.	Asst. Mast. Mech.	1st Lieut.	15th Ry. Engrs.
Rowan, C. R.	Inspector	1st Lieut.	3rd U. S. Inf.
Rudd, W. B.	Asst. R. F. of E.	1st Lieut.	19th Ry. Engrs.
Steins, C. K.	Spec. App.	1st Lieut.	19th Ry. Engrs.
Welch, W.	Foreman	1st Lieut.	19th Ry. Engrs.
Wightman, F. A.	Motive Pow. Insp.	1st Lieut.	11th U. S. Inf.
Woodcock, R.	Asst. Supervisor	1st Lieut.	11th U. S. Inf.
Bartlett, M. W.	Usher	2nd Lieut.	Off. Res. Corps
Bixler, D. S.	Asst. Inspector	2nd Lieut.	413th Teleg. Bat.
Brewer, P. C.	Asst. Supervisor	2nd Lieut.	Engrs. O. R. C.
Brown, C. G.	Spec. Apprentice	2nd Lieut.	19th Ry. Engrs.
Byron, R. G.	Foreman	2nd Lieut.	35th Ry. Engrs.
Corbin, W. M.	Car Repairman	2nd Lieut.	112th U. S. Inf.
Davis, K. N.	M. P. Inspector	2nd Lieut.	Off. Res. Corps
Fahnestock, M. M.	M. P. Inspector	2nd Lieut.	19th Ry. Engrs.
Greely, C. M.	Special App.	2nd Lieut.	21st Ry. Engrs.
Hawkins, A. C.	Apprentice	2nd Lieut.	U. S. Coast Art.
Murray, J. V.	Mach. Helper	2nd Lieut.	Off. Res. Corps
Northrup, C. D.	Fireman	2nd Lieut.	114th U. S. Inf.
Richards, J. S.	Apprentice	2nd Lieut.	311th U. S. Inf.
Schmitt, F. S.	B. S. H. Att'd.	2nd Lieut.	61st U. S. Inf.
Shenck, H. R. D.	Car Repairer	2nd Lieut.	314th U. S. Inf.
Sheaffer, J. G.	Spec. Apprentice	2nd Lieut.	19th Ry. Engrs.
Spencer, F. W.	M. P. Inspector	Ensign	U. S. Navy
Spenser, Jr., W.	Inspector	Ensign	U. S. Navy
Employees who received commissions..... 199			
Total number of employees in government service..... 5,441			

Pere Marquette

Employees who received commissions.....	6
Total number of employees in government service.....	152

Philadelphia & Reading

Employees who received commissions.....	12
Total number of employees in government service.....	1,283

Pittsburgh & Lake Erie

Name	Railroad Position	Military Rank	Branch of Service
Watson, J. R.	Inspection	Engr. 1st Lieut.	Engrs. O. R. C.
Employees who received commissions..... 22			
Total number of employees in government service..... 423			

Pittsburgh & Shawmut

Name	Railroad Position	Military Rank	Branch of Service
Morgan, Jr., D. C.	Mech. Engr.		Av. Sig. O. R. C.
Employees who received commissions..... 4			
Total number of employees in government service..... 23			

St. Louis-San Francisco

Name	Railroad Position	Military Rank	Branch of Service
Sharpe, S. B.	Hostler	1st Lieut.	Field Artillery
Snow, W. W.	Hostler	2nd Lieut.	Infantry
Employees who received commissions..... 26			
Total number of employees in government service..... 744			

St. Louis-Southwestern

Employees who received commissions.....	8
Total number of employees in government service.....	251

San Antonio & Aransas Pass

Employees who received commissions.....	8
Total number of employees in government service.....	101

Southern

Name	Railroad Position	Military Rank	Branch of Service
Caye, W. C., Jr.	Inspector	Captain	Engr. Corps
Bowling, J. D.	Chemist	2nd Lieut.	Marine Corps
Employees who received commissions..... 53			
Total number of employees in government service..... 1,500			

Southern Pacific Lines (Texas & Louisiana)

Name	Railroad Position	Military Rank	Branch of Service
Janes, S. H.	Fireman	1st Lieut.	U. S. Army
Employees who received commissions..... 19			
Total number of employees in government service..... 311			

Southern Pacific (Pacific System)

Name	Railroad Position	Military Rank	Branch of Service
Babeock, A. H.	Elec. Engr.	Major	U. S. Reserves
Williams, W. O.	Master Mech.	Captain	Russ. Ry. Corps
Cirby, A. A.	Loco. Engr.	1st Lieut.	Russ. Ry. Corps
Rutherford, D. J.	Elec. Engr.	1st Lieut.	Russ. Ry. Corps
Waddell, H. C.	Loco. Engr.	1st Lieut.	Russ. Ry. Corps
Jones, A. E.	R. H. Foreman	2nd Lieut.	Russ. Ry. Corps
Wright, G. I.	Elec. Eng.	Lieutenant	U. S. Navy
Houghton, J. W.	Ch. Eng. Pow. Plt.	Lieutenant	U. S. Navy
Hart, J. P.	Elec. Eng.	Ensign	U. S. Navy
Employees who received commissions..... 66			
Total number of employees in government service..... 1,874			

Spokane, Portland & Seattle

Name	Railroad Position	Military Rank	Branch of Service
Bornick, H. A.	Trav. Engr.	Lieutenant	Russ. Ry. Corps
West, B. F.	Boiler For.	Lieutenant	Russ. Ry. Corps
Fischer, J.	Engineman		Russ. Ry. Corps
Employees who received commissions..... 8			
Total number of employees in government service..... 101			

Tennessee Central

Total number of employees in government service.....	73
--	----

Toledo, St. Louis & Western

Employees who received commissions.....	2
Total number of employees in government service.....	60

Union Pacific

Name	Railroad Position	Military Rank	Branch of Service
McClintock, H. E.	Draftsman	Captain	Engineer Corps
McCabe, A. R.	Foreman	1st Lieut.	Russ. Ry. Corps
Reid, M. B.	Motorman	1st Lieut.	Engr. Corps
Employees who received commissions..... 22			
Total number of employees in government service..... 1,240			

Wabash

Name	Railroad Position	Military Rank	Branch of Service
Bennett, H. M.	Loco. Fireman	Captain	
Dixon, E. A.	Asst. Boiler For.	1st Lieut.	Russ. Ry. Corps
Sullivan, J. J.	Machinist	2nd Lieut.	335th Infantry
Employees who received commissions..... 12			
Total number of employees in government service..... 460			

Western Maryland

Total number of employees in government service.....	108
--	-----

Western Pacific

Total number of employees in government service.....	143
--	-----

Wheeling & Lake Erie

Total number of employees in government service.....	138
--	-----

THE IMPROPER LOADING OF LUMBER

Where Open Top Cars are Used for This Purpose
Care Must be Taken to Prevent Lading from Shifting

THE unprecedented measures restricting the use of open cars which have been taken by Judge Lovett, director of priority, show the importance of securing the maximum service from this class of equipment. The tonnage of coal that will have to be moved this winter will break all records and the demand for cars will be greater than

between the lading and not more than 30 in. apart vertically. If the shipper so desires strips may be placed crosswise between each layer of dressed lumber. These rules have been in effect for many years. The revisions which have been made from time to time have been of a minor character.

It will be noted that the rules governing the loading of lumber in open cars are based on the assumption that friction will be sufficient to prevent lateral shifting of the load. The adoption of heavier motive power and the increase in the length of trains in recent years has increased the severity



Good Judgment or Good Luck in Making Up the Train

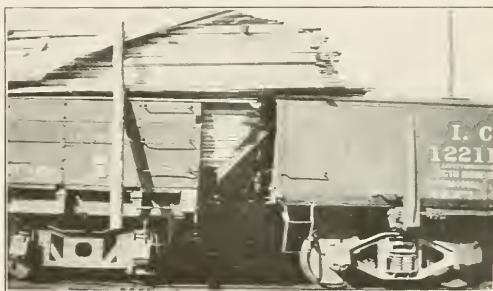

Damaged Equipment Contributes to the High Cost of Transporting Lumber

the supply. Gondola cars will, therefore, be urgently needed for carrying coal. On the back haul to the coal mining regions gondolas are used for many commodities, one of the most important being lumber. It is the purpose of this article to show how greater service can be secured from open cars by better methods of loading lumber, when transported in that class of equipment.

The loading rules of the M. C. B. Association, in brief,

of shocks in starting, stopping and switching. The result has been that the transportation of lumber loaded in open cars has in recent years been a source of considerable trouble and expense to the carriers. The shocks encountered in ordinary service often cause lumber to shift. If any portion of the load slides beyond the end of the car or comes within 6 in. of the brake wheel the car must be taken out of the train and the lading reshaped to conform with the loading



The Transfer Track is a Busy Place

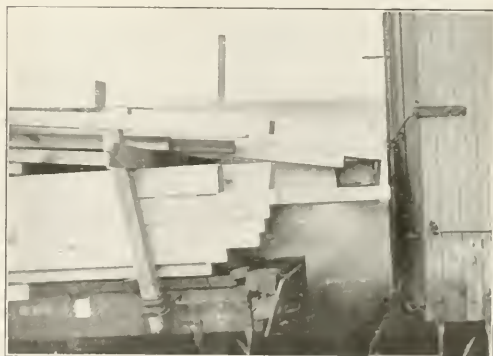

A Load That Will Probably Check Short at Its Destination

provide that lumber loaded in open top cars must not extend beyond the end sill of the car unless protected by an idler, nor within 6 in. of the brake wheel. If the load extends above the side of the car, stakes must be provided to hold the lading at the side. The number and size of the stakes depend on the height of the car side, the height of the load, the number of piles making up the load and the method of loading. The tops of opposite stakes must be fastened together with boards or with wire. Lumber of equal thickness must either be lapped or have strips placed transversely

rules before it proceeds to its destination. The tonnage of lumber shipped in open top cars is large and the loss involved in this switching and reshaping of loads is a considerable item. Some idea of the trouble experienced in hauling lumber in open top cars can be gained by examining the illustrations which accompany this article. All the photo-

graphs of shifted loads which are shown were taken at one yard in a single week.

The Illinois Central a short time ago conducted a special investigation in order to determine the loss of service from cars due to the reshaping of loads which had shifted in transit. During a period of three months this road handled 7,926 cars loaded with dressed lumber. The total car days' delay on these shipments amounted to 17,778, an average of 2.24 days per car. Had it been possible for the Illinois Central to avoid the delays to cars loaded with dressed lumber during the three months referred to above, the road would have had 194 more cars available for service. It is estimated

about 160,000,000 tons. Of this amount about 65 per cent or 104,000,000 tons consisted of lumber wholly or partly dressed, which causes trouble by shifting. Open cars are used to handle probably 25 per cent of the dressed lumber shipped, or 26,000,000 tons. Assuming an average load of 50 tons per car this amounts to 520,000 carloads. As each shipment would require under normal conditions about 18

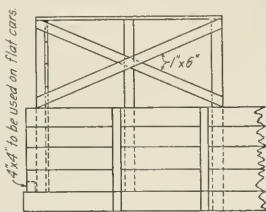
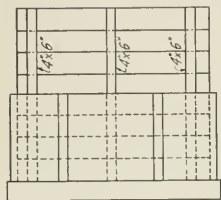
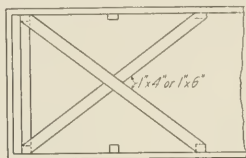

Type of Bulkhead Used on the Illinois Central

that it would have secured increased revenues amounting to about \$85,000. In addition to this there would have been a considerable saving due to the elimination of the expense of switching cars and adjusting loads, and claims for damage to lading. The cost of switching was probably about 50 cents a car and the cost of reshaping the load considerably greater. In the month of May alone the cost of transferring and reshaping loads of lumber at Memphis amounted to



Bulkheads on Lumber Cars Keep the Load Where It Belongs

days from origin to destination, the average number of open cars used in the lumber traffic is 25,600. If an average saving of two days per trip could be secured by bulkheading the cars the number required to handle the traffic could be reduced to 22,800, thus effecting a saving of 2,800 cars. In addition to the saving in equipment there would be further economies due to the reduction of charges for switching and reshaping of loads and also to the elimination of claims for damage to lading.

While the Illinois Central was investigating the delays due to the shifting of loads, a special messenger accompanied one shipment of 50 cars of lumber from a single company. Of these 50 cars 22 were delayed three or four days on account of the necessity of reshaping the load. The railroad had experimented with bulkheads placed in the ends of the cars to keep the lumber in place and had found the results

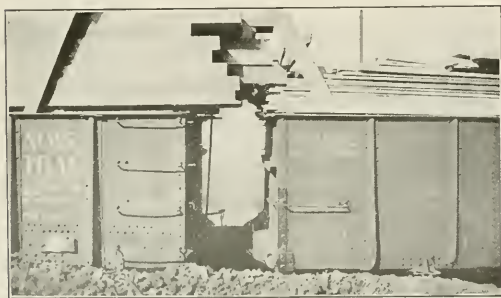

Shifting is Not Confined to the Smaller Sizes of Lumber

\$39,308. Probably one half of this expense was chargeable to loads on open cars.

While accurate data concerning the amount of dressed lumber shipped in open cars on the railroads of this country are not available, an estimate of the saving of cars that would be effected if the practice of bulkheading was generally adopted will show the importance of the subject. The total lumber traffic of the country in the year 1917 was probably

of this practice very satisfactory. It was so evident in this case that the delay was due to improper loading that the company from which the shipment in question was received was persuaded to bulkhead their cars. They have continued to follow this practice and delivery of shipments from this company are now made without the delay formerly experienced. Trains of 50 cars have been brought to their destination without a car removed or sidetracked for reshaping.

The method of bulkheading which has been in use on the Illinois Central for loads on gondolas or flat cars is shown in the illustration. The end is made up of three upright posts, 4 in. by 6 in., to which are fastened 2 in. by 12 in. boards. The corner post is fastened to the third side post by diagonal strips of 1 in. by 6 in. lumber and similar bracing connects the tops of the posts. In case the bulkhead is used on flat cars, a 4 in. by 4 in. timber is placed crosswise at the end of the car to hold the lower ends of the posts in place.

That shippers are willing to co-operate with the railroads in this matter of bulkheading cars is shown by the fact that one large producer of lumber has adopted the practice while the Southern Pine Association has urged its members to con-

I. C. C. SAFETY INSPECTOR'S REPORT

During the calendar year ended December 31, 1916, 136 employees were killed and 2,440 injured in coupling and uncoupling cars; casualties resulting from employees coming in contact with overhead and side obstructions and from falling from and getting on and off cars occasioned 564 deaths and 15,937 injuries. This represents an increase of 13 in the number killed and 246 in the number injured in the former class of accidents, and 59 in the number of killed and 2,126 in the number injured in the latter class of accidents, as compared with the fiscal year ended June 30, 1916.

During that fiscal year, 187 cases, involving an aggregate of 542 violations of the law, were transmitted to the several



Typical Examples of Shifted Loads

sider the advisability of bulkheading their shipments. The main obstacle to the adoption of the practice is the fact that the shippers object to using so much lumber to secure the load unless the roads make a corresponding increase in the dunnage allowance. The present rules of the three principal freight classifications provide that an allowance not to exceed 500 lb. will be made for temporary stakes, dunnage or supports when required to protect and make secure for shipment property on flat or gondola cars upon which carload rates are applied. It has been urged by the shippers that the

United States district attorneys for prosecution. Cases comprising 127 counts were tried, of which 88 counts were decided in favor of and 37 counts adversely to the government; 2 counts are still pending decision. Cases involving 478 counts were confessed, and 10 counts were dismissed.

During the past fiscal year there were transmitted to the several United States district attorneys for prosecution 113 cases, involving 1,197 counts, of violations of the hours of service act. Cases involving 811 counts were confessed and 444 counts were tried, of which 125 were decided in favor

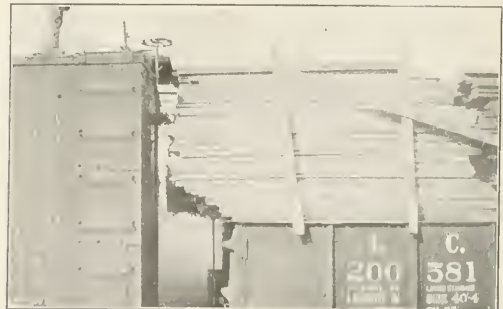

Loads of Lumber Going Out "Over the Top"

practice of bulkheading be made mandatory and the dunnage allowance increased to 1,000 or 1,500 lb. The carriers claim that the lumber used in bulkheading has some commercial value and that the shippers should be able to sell it to the consignee. The shippers on the other hand contend that the lumber used for securing loads has no market value and if additional dunnage is required the allowance provided in the tariffs should be increased.

Both the shippers and the railroads would benefit by bulkheading open cars loaded with lumber.

of the government and 198 in favor of the carriers. The remaining 121 counts are still pending decision. Cases involving 878 counts were dismissed, 841 of which were based upon the carriers' failure to report all instances of excess service, as required by an order of the commission. Two cases were decided by the Supreme Court, one against and one in favor of the government. In the circuit courts of appeal 8 cases were decided in favor of the government, and 3 cases were decided in favor of the carriers. Other cases are still pending.

MECHANICAL DEPARTMENT OVERLOOKING A REAL OPPORTUNITY

Why Not Take Advantage of College and University Facilities?

Engineering Building, Pennsylvania State College.

MAINTAIN INDUSTRIAL FELLOWSHIPS!

BY C. H. BENJAMIN

Dean of the School of Engineering, Purdue University, Lafayette, Ind.

RAILWAY problems are peculiarly attractive to the scientific investigator because they are so definite and so well developed. The railroad man usually knows just what he wants and why he wants it. Furthermore, the investigator knows that immediate practical use will be made of the data which he accumulates or the principles which he proves.

Purdue University was one of the first technical schools to take up railway work, and it has consistently carried out the policies thus inaugurated. The principal credit for the development of railway testing and investigation may safely be given to W. F. M. Goss, and it was through his efforts that Purdue University came to be recognized as the leading authority on railroad mechanical problems.

Beginning with the installation of the Purdue locomotive Schenectady in a separate building in 1895, the organization of a railway laboratory was continued from year to year. In 1898 the Master Car Builders' Association provided a brake shoe machine and an air brake rack, thus inaugurating the official laboratory of the association. Subsequently, a drop press and other apparatus were added. In 1909-1910 the air brake rack was entirely rebuilt and located in a building provided for the purpose. In 1912-1913 a machine for testing eccentric or flat wheels was installed, with the assistance and co-operation of the New York Central.

The various pieces of railway apparatus have served not only for purposes of investigation, but as efficient aids in the education of students.

WORK ACCOMPLISHED AT PURDUE

But a brief synopsis can be given to indicate the work accomplished in the railway laboratories. The locomotive Schenectady, becoming successively Schenectady No. 2 and No. 3, as its design was modified to keep up with the times, served first as a medium for Dean Goss' experiments on high steam pressure and on superheat. These experiments

form the basis of his various publications on "Locomotive Performance," "High Steam Pressures in Locomotive Service" and "Superheated Steam in Locomotive Service."

The work on superheated steam was continued by Professor Endsley, and formed the subject of a paper presented to the American Railway Master Mechanics' Association by the writer at the 1912 meeting.

Other experiments on this locomotive have concerned the performance of various front ends, stacks and exhaust nozzles, spark arresting devices and superheaters.

The brake shoe machine has served its purpose in establishing the loss of friction and wear for different types of shoe. The work done on this machine has furnished the basis for the standards now in use by the M. C. B. Association. A résumé of these tests is given in the proceedings of the Association for 1915, Vol. 49, p. 59.

In a similar manner, the work done on the air brake rack and the drop press has furnished data for the standard specifications now in use by the railways.

The laboratory for testing materials has had an important part in railroad work. Among the more recent investigations carried on in this laboratory are detailed studies of side frames and of brake beams where, by the use of a strain

THE UNIVERSITIES can do much for the railroads in the way of making special investigations and tests, but the latter must do their part in providing the funds. Dean Benjamin, of Purdue, suggests that one way of doing this would be to maintain industrial fellowships.

Professor Schmidt, of Illinois, suggests that the railroads contribute to keep the locomotive laboratory in continuous operation. It seems a shame that the roads do not take advantage of this opportunity, particularly since so many profitable fields of investigation are still unexplored.

Professor Wood, of Pennsylvania State College, makes some splendid concrete suggestions for a practical "railroad-college" course. Surely it is time that the leading railway mechanical associations made some progress in solving the big task of really training men for the important work of the mechanical department.

gage, local deformations and stresses were analyzed and accounted for.

CO-OPERATION—A PRESSING NEED

As long as new standards are adopted and new designs originated by the railroads, the co-operation of the university will be demanded. He would be a rash man who would predict that improvement in railway design should in the next twenty-five years be any less marked than in the twenty-five just passed.

One way in which the railroad may co-operate with the university to their mutual advantage is by *maintaining an industrial fellowship, the incumbent of which shall devote the whole or a part of his time to investigating railroad problems. Such assistance is a pressing need at the present writing.*

RAILROADS SHOULD MAKE USE OF LOCOMOTIVE LABORATORY

BY EDWARD C. SCHMIDT

Professor of Railway Engineering, University of Illinois, Urbana, Ill.

The University of Illinois has for years co-operated with the railways in research, and it conceives such co-operation to be one of its duties. It has frequently received assistance from the railroads in prosecuting its own problems, and it has, on the other hand, given assistance to many roads in problems initiated by them. In co-operation with the railroads it has carried on, during the last fifteen years, a *good deal of research in such fields as train resistance, tonnage rating, car truck design, coupler design, the design and performance of water columns, stresses in car wheels, stresses in railway track, the performance of different kinds of coals, brake shoe performance, etc.*

Whenever the investigation proposed seems likely to produce results of scientific quality and of general interest the university stands ready to contribute the use of its equipment and the services of its staff. In special cases it has contributed also a portion of the funds needed for such investigations; although it has never seemed to us that we should be expected to go that far.

Our locomotive laboratory is as well equipped as any in this country to test modern locomotives. While we have been able thus far to carry on enough laboratory work to serve our own purposes and to justify the installation of the plant, it has not been in constant operation, nor have we ourselves the funds to keep it constantly at work. *We should be glad to enter into co-operation with any railroad or with any group of railroads looking toward the fuller use of the laboratory, either in the study of a particular problem or in varied investigations extending over a term of years.* We have already made to certain roads proposals to this end and we stand ready to renew them at any time. Four or five thousand dollars contributed by each of a half dozen roads would suffice to keep the plant in continuous operation for a year. We should be willing to contribute to such a purpose the use of the plant and the services of members of our staff without charge. Whether we should be willing or able to offer any larger measure of co-operation would have to be determined in the particular instance; but even this contribution on our part offers to the railroads what has always seemed to me an exceptional opportunity for the solution of the numerous problems which present themselves to railway officials.

ADVANTAGES OF LABORATORY TESTS

The advantages of laboratory tests over road tests probably need no further defense. Most of us who have had experience in both are willing, I think, to concede that even where the problems can be worked out with equal accuracy in the laboratory or on the road, the laboratory procedure is likely to be very much less expensive; and there remain, of course,

many problems in locomotive performance and design which cannot be attacked by road tests with any prospect of success. Neither will any one deny the great need for further research in railway problems. There are numerous questions to be solved and new ones continually present themselves. The demand for their solution is all the more urgent at such a time of emergency as the present; and the prevailing tendency to make the emergency an excuse for deferring all such work seems to me short-sighted and unwise.

One of the chief functions of the Engineering Experiment Station of the University of Illinois is to do whatever it can to promote such co-operation between the universities and the industries as is under discussion, and we may be relied upon here always to do our share in any such enterprise.

CO-OPERATIVE "RAILROAD-COLLEGE" COURSE

BY PROF. ARTHUR J. GOOD

The Pennsylvania State College, State College, Pa.

Who is to train the future railroad mechanical engineers? The question cannot be evaded. It means much more to-day than it did even a year ago, and no railroad official can fairly answer, "That is not *our* job. The engineering schools must speed up." My aim is to point to a better way than suggested by this reply, and to indicate how co-operation may become effective. Col. H. G. Prout, when general manager of the Union Switch and Signal Co., once remarked, "The spirit and the temperament which make co-operation not only possible, but natural, are essential to any success in any great enterprise. I am not speaking of perfunctory or official co-operation, but of the spirit which makes folks work together to a common end, by instinct and inclination."

The railroads do not have in training a sufficient number of men of the right stuff. Here is a typical example: Of last year's graduates of the Pennsylvania State College, two-thirds of those in railway mechanical engineering are now in France with Company E, 19th Engineers, and not one of those in mechanical engineering is in railroad work.

RAILROADS AND COLLEGES SHORT-SIGHTED

Most of the mechanical engineering graduates who enter railroad engineering departments and rise to places of influence have become attracted to the work before leaving college. Aside from possible home influences, they are not usually drawn in that direction, partly because mechanical engineering is many sided and in most colleges the student receives instruction in the various mechanical lines—*except in railroad engineering.* Again, not more than about one out of ten teachers of mechanical engineering is familiar with the transportation problem, and naturally this line of service has not been given its due weight. On the other hand, the railroads as a whole expect a certain product, but have not studied the question thoroughly, and have placed a load on the colleges which they themselves should share in carrying. This condition has been apparent for years, and both the railroads and colleges have been short-sighted.

The point at issue should be kept clear. I am not urging specialization. The college, first and last, must teach fundamentals, and teach these thoroughly; but every college is a profit-sharing enterprise and must balance its account with those who supply the funds. In all this work, the college is the specialist aiming to render efficient service. The student is being fitted to be of real value in the world, and he should have a touch of active engineering work to help in a wise choice of vocation. It is the business of the college to help him to find himself.

GOOD EXAMPLE OF CO-OPERATION

The Pennsylvania State College is located fifty miles from one of the best engineering laboratories in the country.

I refer to the Altoona shops of the Pennsylvania Railroad. Co-operation has been made effective along the following lines: Six years ago the college organized an apprentice school at the Altoona shops, which has since been doing good work under a joint agreement; engineering problems have been worked over together; lectures have been given by engineers of the company; investigation work has been carried on at the college at the instance of the railroad; frequent inspection trips to the shops have added interest, and the company has donated a dynamometer car, a locomotive and other equipment.

Of more direct value in the training of college men is the work at the locomotive testing plant. To better appreciate this aid, reference may be made to one of our recent trips to Altoona. Twenty-six senior mechanical students spent two days at the shops. The party was divided into two sections or groups, one of these went through the shops and laboratories under the guidance of an engineer especially qualified to make the inspection of value, while the other group was at the testing plant. This group was shown the layout, method of conducting the tests and the main-line purpose of the testing plant. Each student then put on his overalls and, being assigned to take certain readings, filled out the log sheets, being guided by the trained employees of the company. The data, with a sample of coal, were taken back to the college, the results worked up independently and a careful report was made of the test. This study presents to the student the locomotive as a power plant, gives a tie-up to theory and practice and makes for a better prepared graduate. J. T. Wallis, general superintendent of motive power, and the engineers of his staff have generously co-operated, and many colleges have been benefited by studying the methods used jointly by the Pennsylvania Railroad and the Pennsylvania State College.

For years the students have made test runs with the college dynamometer car and locomotive over the lines of the Bellefonte Central Railroad. Recently, the Westinghouse Air Brake Company presented to the college a compound air compressor with testing equipment, and in return the Engineering Experiment Station submitted a careful report of special tests on the compressor.

CONCRETE SUGGESTIONS

While each case calls for its own solution, the writer urges careful consideration of the following suggestions:

(1) Special courses should be given to a limited number of men in the engineering departments of the railroads who have not had a college education. Two leading qualifications should enter into the selection, (a) fitness, and (b) probable permanence as an employee of the company.

(2) As an emergency measure, cut down the special apprenticeship time to a minimum, making the training more intensive.

(3) Let each railroad have one of its men make frequent trips to a university, become acquainted with the faculty and the courses and encourage undergraduates to work during vacations in the shops and laboratories. Having tested out a young man, make him feel that there is a place in the organization which can be won by hard work.

(4) Railroads should be on the lookout for bright fellows in regular apprenticeship courses and encourage such to take a college course, keeping in close touch with their work while away from the shop.

(5) The college should look into more of the live problems of the railroad mechanical engineer.

(6) The American Railway Master Mechanics' Association should have an active committee working on the question. Each railroad and at least one college in every state should lay out a clean-cut policy and should co-operate with such a committee. Let this committee propose a general policy for a co-operative "railroad-college" course.

PRACTICAL RESULTS FROM MODERN APPRENTICESHIP

BY H. S. RAUCH*

General Foreman, New York Central, Avis, Pa.

At this time, when the need for trained mechanics is so great and the supply so limited, modern apprenticeship methods can play a large part in overcoming the difficulty.

With the aid of properly applied apprenticeship methods, modeled on the lines of the New York Central or Santa Fe and supervised by competent instructors in class room and shop, young men can be made proficient from an output standpoint in a very brief period of time and in addition accumulate a mechanical education that will be invaluable to themselves and their employers.

Take a specific case: a young man 17 years of age, physically strong and mentally equipped with a good common school education, is placed in a shop under the tutelage of a competent instructor; one who is in sympathy with him and qualified to bring out the best there is in him. He is put to work on a lathe on which the more simple classes of work are done and in ten days or two weeks will produce the capacity of the machine. Leave him there three months and then move him to a more important lathe, giving him careful attention, and he will soon be producing to the capacity of this new machine, and so on, through his four years' course. In all this, the apprentice school is playing an important part, as he learns from the first to make sketches, read blue prints, and to supplement his mathematical education and apply it to mechanics. His education in the class room is dovetailing into the shop education and producing efficiency in months which would take years under the old method of letting him shift for himself, with an occasional call down from the "boss" because he did or did not do something he should or should not have done.

It is a duty which the railroads owe to posterity, properly to train young men to fill the places of the older ones, who will not always stay at their posts.

Railroads have outgrown themselves, have outgrown the number of available workmen, and the only way to anywhere near meet the situation is to train the boys who are under the military age. Give them an intensive training such as our government is doing with the men in the National Army.

Let it not be understood that the writer desires to convey the idea that a shop can be run wholly by apprentices, but rather that the gap can be filled to a very large extent by a modern and intensive apprenticeship system.

A word about the apprentice instructors: These men must be carefully selected and must be men who are in sympathy with the boys; men who understand human nature in the making, and who are capable of getting the best efforts from the boys; men of high integrity and honesty who can be looked up to by these embryo mechanics and who in that way will raise the boys to their level.

It should also be understood that all does not rest with the instructors. Shop officials must interest themselves in the welfare of the boys, giving them a word of encouragement occasionally, and dropping into the class room and becoming acquainted with the boys and the character of their work as much as their time will permit.

When the apprentice graduates are assigned to work as mechanics, the chief officer of the plant should have a short talk with them, endeavoring to draw them out as to their desires and aspirations. This will aid in placing them to better advantage and at the same time will make them feel that their existence is known to those in charge and that their efforts will be watched.

* Mr. Rauch was formerly an apprentice instructor, and has a close interest in and sympathy for the apprentice.



MORE SERVICE FROM THE EQUIPMENT

Railroads and the Different Departments Must Co-operate for Maximum Service from the Facilities

BRIEF SUGGESTIONS from various men in charge of mechanical departments of railroads in both the East and the West for improving the general equipment situation are given below. Some of these are quite original and all of them are pertinent to the prevailing conditions. They are constructive and show that the mechanical departments of our railroads are alert and seeking to successfully meet the extreme demands for power and equipment.

CO-ORDINATE REPAIR FACILITIES AND MATERIALS

BY J. H. MANNING
Superintendent Motive Power,
Delaware & Hudson

I know of no better way of increasing the activity of the power than by fully maintaining it; what the future will bring forth is too indefinite to defer maintenance, and risk semi- or complete breakdowns which would affect so widely the entire transportation problem. It has been demonstrated that power can be properly maintained with no more than eight per cent, or better, of a total locomotive equipment out of service. This should be done even if it is necessary to increase the activity of the shop by establishing a night force with skilled help and by promoting competent helpers or handy men in case regular mechanics cannot be obtained.

There should be closer co-operation between the different railroads in regard to the general repair of locomotives with a view of having those roads which can repair locomotives for such roads whose shops and facilities are taxed beyond their capacity. There is no question but that parts of the country will have more and better labor than other parts.

It would not be feasible to transfer the workmen, but it would seem entirely practical to move the power requiring attention to the point where assistance can be given.

A committee could be appointed by the railroads to

canvass the entire power situation of the country with a view of determining, first, what locomotives are awaiting repairs and the possibility of their being taken care of by the owners, and second, the reason for their being held for repairs, such as for want of material and the kind of material lacking; for the want of help and the character of the help, and for want of proper shop facilities and the character of these facilities. It is entirely possible that other railroads might have a surplus of material or that they could spare some of the particular material which a certain road lacks and in this case a transfer could be made. If it is due to insufficient or defective labor, probably something could be done in this direction. If it was due to inadequate facilities it is entirely possible that another railroad might have sufficient capacity to take care of those roads in difficulty. This committee could further assist the railroads

THE important problem confronting the mechanical department is keeping the equipment in condition for active service. This can only be accomplished by hard and conscientious work. No short-cut or temporary practices can successfully be followed. The equipment must be maintained, improved and loaded to capacity. Repair work must be done right and made to last. As Mr. Manning says: "What the future will bring forth is too indefinite to defer maintenance and risk semi- or complete breakdowns."

Every minute a car or locomotive is out of service for repairs should be made to count. All departments must co-operate with each other. Every railroad must be willing to assist its neighbor. Every employee must keep his country's need constantly before him. Organization, co-operation, industry and intelligent use of one's resources are necessary for success.

by anticipating the requirements of the badly pressed roads along the above lines and thereby reduce the time it is necessary to hold the locomotives out of service.

By putting such information in the hands of this committee it would bring under one head the needs of the railroads in the mechanical department and would give it concrete information which it could lay before the proper representatives of the government in Washington and urge upon them the necessity of promptly delivering material to suc-

cessfully meet these conditions. The same co-operation could also apply to cars.

ENCOURAGE THE EMPLOYEES

BY GEORGE DURHAM

Superintendent of Motive Power and Cars, Wheeling & Lake Erie

There is a very great deal that might very properly be said on the subject of what can be done to increase the efficiency of the mechanical department at this particular time, but without attempting to say all there is to it, I suggest that one of the most important things in connection with the whole situation is the necessity for courage and cheerfulness on the part of supervising officers which *must* be transmitted to the forces by *personal* contact.

The superintendent of motive power, master car builder, master mechanic, road foreman of engines, roundhouse foremen and gang foremen will all have to get closer to the job that they may *know* (not guess) what is required, and encourage the forces under their direction by personal example and precept (not by abuse) in the important matters that are before us, and *must* be taken care of.

EXTEND LOCOMOTIVE RUNNING REPAIRS AND ADOPT A DEFINITE CAR SHOPPING PROGRAM

BY A MECHANICAL SUPERINTENDENT

Of course, the way to get the greatest possible use out of equipment insofar as the mechanical department is responsible, is to have the largest amount of equipment possible ready for service. In other words, to have out of service only such equipment as is absolutely necessary for a reasonable shopping margin.

With regard to locomotives, it is my opinion the thing to do is to have a program of assigned mileage for all classes of locomotives, which mileage they must make before they pass through the back shop for general repairs. When general repairs are given to locomotives the work should be of such a thorough character that maximum mileage can be obtained before they are again returned to the back shop. We have made quite a study of this matter and have accomplished considerable along these lines. It is particularly important to exercise great care and judgment in repairs to the boilers. Tight boilers mean that the locomotives can run longer before they are obliged to return to the shop for general repairs. Roundhouse forces can be encouraged to repair the machinery and run it along for a great length of time, but when the boiler begins to weaken, it is a very difficult matter to do much to the locomotive, except send it to the back shop for general repairs. We have been very careful with our boiler repairs in the back shops. We are welding the flues of all locomotives to the back flue sheet electrically. We also have our back shops piped with gas, as we find that each method of welding has its own field. We are satisfied that making proper boiler repairs has been a big help to us and it has enabled us to increase the mileage between shoppings. We are averaging a little less than 7 per cent of our locomotives in the back shops.

We have a definite program for back shop repairs to freight cars. By so doing we not only reduce the maintenance cost of freight cars, but reduce the number of bad orders. At the time that back shop repairs are made to freight cars, all necessary repairs should be made. If the design is inadequate to meet present conditions, the weak parts should be reinforced. If it is not practical to do this, the car should be destroyed and written out of service. Another very decided advantage of this method of handling freight car repairs is that you can notify the supply department and purchasing department a year in advance, if necessary, what the repair program is going to be, and thereby enable them to line up the necessary material for carrying

out such a program. Of course, the material situation is a serious one in this country now, and in many instances it controls the kind and the extent of repairs to be made. Fortunately we have been able to overcome this trouble by outlining our program far in advance. As an illustration; for our 1918 freight car repair program we now have practically all the manufactured material lined up. With such a program for the last year we have averaged each week about 3 per cent of our freight cars in bad order.

SYSTEMATIZE REPAIR WORK

BY F. J. HARRISON

Superintendent of Motive Power, Buffalo, Rochester & Pittsburgh

At the present time the Buffalo, Rochester & Pittsburgh is doing an enormous amount of business and everybody connected with the railroad is extremely busy. We have found that by scheduling engines through our shops that the output of the shops has been materially increased. We are also following the practice of holding out of service at engine terminals only those locomotives which can be given prompt attention and returned to service with a minimum delay. The workmen in the engine houses are organized under gang leaders which has been found particularly helpful. The supervision of repairs to the locomotives has been tightened up, which insures better work being performed. The locomotives in all services are assigned to regular crews which we believe will be of great assistance. The mechanical department officers have frequent staff meetings at which important problems are discussed.

CO-OPERATE TO REDUCE ENGINE FAILURES

BY F. W. TAYLOR

Superintendent of Motive Power, Missouri, Kansas and Texas

To get the greatest possible use out of the equipment in charge of mechanical officers is the problem that is uppermost in their minds and receiving their best thought and action. Particular attention must be given to putting the locomotives through the shops promptly and making the repairs thoroughly. After a locomotive has been turned over to the transportation department everybody should co-operate to increase the service life of the locomotive and make it produce the greatest possible mileage. Every effort should be made to reduce and eliminate the engine failures. The locomotive should be passed through the engine terminals in the shortest possible time. It is important that a good grade of coal be provided, as with poor coal the proper service cannot be obtained from the locomotives and engine failures will occur. The water supply is another very important thing. Bad water materially shortens the life of the boiler, which is the backbone of the locomotive. The kind of water used should be given careful consideration and the best methods of treating it determined.

DON'T PUT ENGINES OUT UNTIL THEY'RE RIGHT

BY GENERAL MECHANICAL SUPERINTENDENT

The mechanical department, to get the greatest possible use out of the equipment in its charge, must always aim to keep the power in condition to give maximum efficiency, and to keep the bad order cars down to a reasonable figure. Do not send locomotives out unless work has been done which will allow them to go over a division without delay or failure. In times of stress it is a common error to neglect the work, but it is far better to hold a locomotive for needed repairs than to send it out in a condition which will almost insure a failure. It has been our practice for years to do the work required, and the answer has been found in the prompt movement of trains.

Hysterical calls for locomotives that have not yet arrived do not move freight. Have the work done in so far as possible, if maximum tonnage is to be moved.

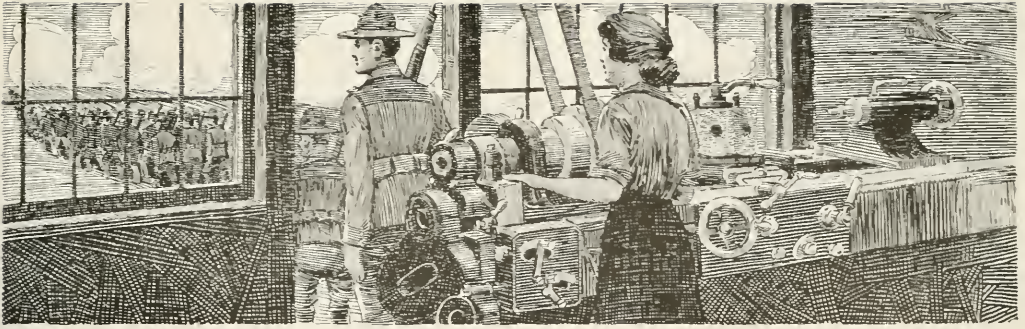

WOMEN FILL MEN'S PLACES IN SHOPS

Roads Employing Women Find Results Satisfactory.
Suggestions for Their Employment and Training

THE MEN in the mechanical departments need a spirit of patriotic service to carry on their work during the present crisis. The foremen must impress on the men that they are "in the trenches," that they are doing as much for their country as if they were wearing uniforms at the battle front rather than overalls in, perhaps, the dingy shop.

In spite of the large numbers of men in this country who are skilled in the shop trades there is already a serious shortage of mechanics. When more are taken away, energetic measures will be required to cope with the situation. The government will demand large forces of skilled mechanics as the number of men in the army increases. The technical branches of the army comprise about half the entire armed forces. It will be necessary for the United States to manufacture enormous quantities of munitions which will also require the services of many skilled mechanics.

This country has as yet adopted no definite method of handling the labor problems caused by the war, and some industries, by offering higher wages than the railroads can pay, have drawn large numbers of men from the shops. In many cases it is very difficult to fill the places thus made vacant. With the marked shortage of labor one of the principal incentives for maximum production has been lost. Men have formed the habit of "laying off" more frequently and some shops report that it now takes three men to do the work that two formerly did.

Instilling a spirit of patriotic service in the men will help

the situation but this will not fully overcome the difficulty. The railroads will undoubtedly find it necessary to put into practice the "dilution of labor," which has produced such wonderful results in Great Britain. In the British shops, women or unskilled men are brought into the plant to do unskilled work, and the workers whose places they take are put

on some of the simplest jobs. The men who have been performing simple operations are put on work requiring more skill. This grading up process is continued throughout the ranks and thus the shortage of skilled help is overcome. Another method adopted has been to confine the best mechanics to those operations where their skill was necessary. These measures have made it possible to use women on a great variety of work. There is one shell shop in England which has but one skilled mechanic for every fifty women and in point of output it ranks among the first in the country.

SELECTION AND TRAINING OF WOMEN WORKERS

BY D. C. BUELL.

The experience of England, France and Germany under the most trying war conditions has demonstrated the fact that women can be used to replace men in practically every

branch of industrial activity. The question is not *can* they be used, but *how*, when and where *should* they be used?

There is nothing particularly difficult in either the selection or the training of women to take the places made vacant by men in many branches of railroad work. In fact, the apparent ease with which women can be substituted

"IN NINETEEN FIFTEEN all our employers regarded the introduction of a woman into a machine shop as one of the horrors of war, about on a par with Zeppelin bombing and the shortage of sugar," said one of the officers of the labor supply department of the British Ministry of Munitions, speaking of the part women have taken in the industries of Great Britain. "But," he added, "the woman has been found to be a better and more conscientious worker than the unskilled man."

The labor problems of the railroads are daily becoming more serious. Increased output is demanded, yet the supply of men is constantly decreasing. Everything indicates that this country, like Great Britain, will find it necessary to employ women in large numbers. The experience of the roads that have employed women labor has been very satisfactory. Those who have not yet adopted this measure should consider it.

for men is apt to be misleading. The real problem in connection with the employment and use of women in railroad service is two-fold. First, the analysis of practical conditions to make sure that women can be properly and efficiently substituted for men; and, second, the supervision of women as they are employed to make sure that they are properly instructed in their duties and are let alone so that they will have an opportunity to "make good."

In foreign countries where large numbers of women have been employed, there has never been any question as to women being able to do things—even unusual things. The failures have been due to the use of poor judgment in selecting work for them, and in the failure to place them in surroundings where their health would be conserved. The most serious phase of the problem has been in allowing women to work in surroundings or under conditions where it was hard to maintain standards of morality. In fact, reports indicate that in many sections of Germany, and in some sections of other countries, where women have been thrown indiscriminately with men, the standard of morality has fallen to such an extent that conditions are almost indescribable.

No country has higher ideals of womanhood than America. These ideals must be maintained in spite of the tragedy of war, and they can be maintained even though large numbers of women are employed in varied industries, if those responsible for their employment give the subject the careful study and attention which it requires.

Where conditions indicate the necessity of employing any considerable number of women in railroad service, the preliminary step, before the plan is undertaken, should be the making of a careful survey of the entire situation to find out in what places and in what numbers women can be economically and practically substituted for men. This survey may include only one department, but to be most effective should include every department of the railroad. In making such a survey, due consideration should be given to the hours-of-service laws regulating the employment of women in the various states; to the customary working hours in different offices and departments; to the question of whether additional facilities, such as toilet rooms, dressing rooms, rest rooms, separate lunch rooms, etc., would be required, and the expense involved; and to the conditions under which the women would have to work and still be properly supervised and safeguarded, to make sure that the sexes would not be brought into undesirable association. The question of fatigue should also be considered; in other words, consideration should be given to the amount of nervous strain under which the work would have to be done, to the question whether the work would require the employees to stand all day or not, to the amount of physical exertion required to do the work, etc. Such a survey would disclose many positions where women could be readily used, and many other positions where they could be used if conditions became acute, with a readjustment of working hours or working conditions.

The employment of women in any considerable numbers immediately brings up the problem of the training of women to fill efficiently positions to which they may be assigned. In a large number of cases, women can be put to work immediately without any special preliminary training, by having skilled workmen assigned to show them what they are to do and to instruct them in the way to do it. In Great Britain probably twenty times as many women have been trained in the plants as in the schools. Only by the co-operation of the skilled men who have willingly trained women in the shops has the British Government been able to obtain the present enormous output of munitions.

On the other hand, it is, no doubt, desirable in many cases to give preliminary training to prospective women employees when it is practicable to do so. Shop surroundings are

entirely strange to the great majority of women. Not only must they become accustomed to the noise and confusion of the shop; but, in addition, they must learn the intricacies of the particular machines or work to which they are assigned. If they could be given a brief preliminary training, to accustom them to at least a part of the new work ahead of them, it would undoubtedly enable them to fit into their new work more readily, and be a considerable factor in reducing the number of minor injuries to which women are now subject in starting work in shops.

One plan for giving preliminary training to women who are to be employed in railway shop work, which would seem entirely practical, would be to arrange with public school and university authorities at various points where these institutions have manual training departments or shop facilities, so that night classes could be formed, under the direction of competent instructors or foremen, to familiarize women with the fundamental principles of machine-tool operation. In such night classes, machines, machine operation, and machine shop methods could be explained. The women could be given actual experience in setting up work in machines and in some of the more common machine operations. They could be taught the different classes of tools used and the proper methods of setting tools for different classes of work. The uniform that was to be adopted in the shop could be furnished, and the women accustomed to wearing this uniform before actually entering the shop. Two or three weeks of such preliminary training, under proper direction, would be sufficient to take away much of that strangeness which a woman who enters the shop for the first time to go to work now feels. In view of the hearty co-operation which would be given to a plan of this kind by schools and universities, it would seem that it was worth more than passing consideration.

If it were not possible to arrange for training school facilities outside of the railroad shop, there is no reason why a night training class could not be formed right at the shop, and a similar course of instruction given four or five evenings a week during a period of several weeks, to acquaint prospective employees with the work before them.

Such a scheme of night training would permit many women who were employed during the day, to take advantage of the preliminary training during the evening, without loss of time or money. Such a training class would permit the foreman or instructor in charge to weed out undesirable or inept applicants, and the plan could be flexible enough so that just as soon as the instructor considered a student competent, arrangements could be made for her immediate employment. Such a scheme would also provide a supply of applicants from whom to draw to meet the fluctuating demands of the shop for additional help, while the expense would be negligible.

One general complaint about the employment of women in railroad work that is usually done by men is that women lack initiative. However, it must be remembered that a woman in most cases is absolutely ignorant of the nature of the new work assigned her. In the majority of cases, a woman entering a railroad shop has only a vague idea of what a locomotive is. She naturally knows what it is for and what it does, but she has no knowledge of either the names or the functions of its various parts. A part of the training of women for railway shop work should consist of lectures and explanations not only of the tools used in the shops, but of the machines which are being made or repaired, in order to give these women as broad a point of view of their work as possible.

The people of this country are rapidly gaining a clearer realization of the magnitude of the task of winning this war and the important part that women must play in helping to win it. There will naturally be some doubt as to the ability of women to "make good" in different branches of shop

work; some inconvenience may be caused during the time work is being rearranged so that women can be used effectively; but the patriotic co-operation of foremen and men in instructing and helping those women who are brave enough and patriotic enough to undertake strange work in new surroundings will insure success.

THE FEMALE WORKER IN RAILROAD SHOPS

BY HARVEY DEWITT WOLCOMB

"Are you hiring any experienced milling machine hands?" The questioner was a pretty young lady, dressed in the height of fashion and very much out of keeping with the dusty and grimy shop office. She addressed this inquiry to the general foreman on one of the large eastern roads.

The foreman displayed no surprise at seeing a young woman in such discordant surroundings. This particular company was in need of milling machine hands and by closely questioning the fair applicant, he soon proved to his own satisfaction that the girl—for she acknowledged she was only 19 years old—had a good knowledge of machine work and was competent to handle regular milling machine operations. She was employed on the conditions, to which she gladly consented, that she wear bloomers or overalls, tie her hair up in a tight fitting cap or net, wear safety goggles when operating any machine, remove all jewelry from fingers and hands and last, but not least, wear no gloves when operating a machine.

Six months' actual experience has proved that, if these precautions are observed, the female worker is less liable to accidents than a male workman. This is probably due to the fact the female worker is more careful. In a railroad shop employing women machine operators, for six months a careful record was maintained of 15 new female employees and the same number of new male employees. During this period only one injury occurred to a female employee as against many to the men. It is worthy of mention that the accident which the female worker suffered was of a very trivial nature and was caused by breaking one of the rules of employment noted above.

The safety of male workmen in shops has been neglected and this is one of the very good reasons why the more extensive employment of the female worker should be advocated. The average railroad shop buildings are so situated that the men in charge feel that there is no safe way for women to reach them. If such dangerous conditions exist immediate steps should be taken to correct them. The benefits of the movement to introduce female workers will then react on the entire force employed.

In questioning women applicants for employment, it is surprising to note how many have had factory experience of some nature so that to a greater or less degree, they are familiar with the shifting of belts and realize the danger of coming in contact with moving machinery. This previous experience may be one of the principal reasons why women learn so readily to handle the machines to which they are assigned. At one large shop it was found that after less than one day's time spent in learning how to operate a sensitive drill press a new girl produced as much work as a boy with considerable experience on that machine.

The experience of the large systems that are hiring women in large numbers and placing them in the shops proves that the claims made by some who have not as yet tried this class of help, are groundless. It has been predicted that the discipline of a shop would be lowered, but this has not been found to be the case. In the first place, the female worker should be classed and handled as a "working unit." That is, she should be given to understand she is employed to produce a day's work, and just because she is a woman is no reason why she should be allowed to disregard the rules of the shop. The railroad officer who feels that it is wrong

to treat a female worker as a "unit" should visit some of the large factories employing many women where special systems have been worked out to suit the conditions to the workers. As a concrete example, take the question of providing stools to allow the women to sit down while operating machines. The average shop foreman will claim this is unnecessary, for railroad shops have been run for fifty years with every workman standing up, but on the other hand, it has been found that on some jobs the sitting position actually results in an increased output. Some shops have made special efforts to develop, along scientific lines, a stool that will permit the operator to produce the most work with the least fatigue. Much actual shop production has been lost because the traditions of the shop were "to stand up."

Another tradition has been to hire a man and put him to work on his own merit. If he spoiled a job, he was fired, but if he "got away with it," that is, could handle the work fairly well, he was retained. This resulted in keeping the class of workmanship at nearly an equal level, for personal incentive was eliminated; in fact, personal endeavor was not sought. In recent years it has been found that with good instruction, the average workman can improve and increase his production with no extra effort. In placing a female worker in the shop, this should be borne in mind and instruction provided at the start. As a rule, the female, working at a disadvantage will at first endeavor to do too much, and if her efforts are not directed along the right lines, she will soon become discouraged and leave thus making it necessary to break in another employee. The choice of a position for the female worker should be handled with the same common sense as the placing of male workmen.

While the employment of female help has not been as general as it should be, only the largest systems taking up the movement to any great extent, the success of women in shops has been proved and it will only be a short time until all the roads are forced to protect themselves from the shortage of labor caused by men leaving to take up employment elsewhere, or entering the government service. Many of the medium sized railroad shops claim they have no openings where a woman can be used to advantage. In England war necessities have given the government authority to handle labor matters, and the labor bureau has greatly increased production by demonstrating to the manufacturers that by making certain changes it is possible to advance workmen and introduce female workers and so secure the desired production. As yet we have not reached this stage in America.

We have been a peaceful nation so long that it is difficult for us to change our practices quickly to conform with the present needs. The making of the change is an educational process in which the railroads, as centers of influence, can play a very important part, for few industries have entered more whole heartedly into the win-the-war spirit. Railroad labor is scarce, but by a proper rearrangement of workers and the introduction of women, the roads can protect their own interests as well as help out the present critical labor shortage in the industrial field.

THE FIELD FOR WOMEN IN RAILROAD SHOP WORK

BY MISS MARGARET LAMPERT*

It is interesting to observe the manner in which women are meeting the new situation confronting them in the industrial world. They are being given an unusual opportunity to help themselves and their fellowmen to better things industrially than they have dared hope would ever be their fortune. Not only are they given the opportunity to prove their loyalty to their country by stepping into the places so recently made vacant by those who have joined the army or navy, but they are also permitted to prove to the

*Miss Lampert is a former high school teacher who has worked as a lathe operator in the machine shop of a western railroad.

world their ability to cope with the problem so long cherished by man as his peculiar task.

They are already proving their patriotism, for many women are now employed in the railroad shops. Those who have entered the field have shown ability, with eagerness to master the problems met. They receive the inheritance of the same parentage and some of them must therefore possess the same talents as their brothers. The same environment or training added to this same inheritance must of necessity show some women to be as capable as some men in mechanical labors. Prejudice has heretofore prevented their entrance into what has been regarded as man's domain. Now that women are needed in the mechanical world we are learning that they have the powers latent which man has been exercising and developing for centuries. Indications are strongly in favor of their success in coping with man's mechanical problems.

The women who have responded to the call for aid in the shops have come from all walks of life. There are milliners, dress-makers, nurses, teachers, clerks, housewives, hired girls, factory girls, and girls who have never before earned money. Naturally, they come from all classes, from the ignorant to the college graduate, just as do the men beside whom they work. The shop superintendents, however, exercise care in the selection of women for shop work in order to prevent the introduction of the rough element.

The motives inducing women to come to the shops are as varied as are their stations in life. One came because it gives such freedom from the "double standard" of pay that she has met in cafe and factory. Another has come to aid her husband in paying off a doctor bill contracted in his long illness. Still another saw the opportunity to gain practical experience to enable her to teach physics from a broader viewpoint. The chance to serve the country appealed to another. But that none came for the sake of being conspicuous was shown when a local paper wished to take a photograph of the group in unionalls for publication. Without exception these women shrank from such publicity. As one woman put it, "We're not here for exhibition."

Women have met unusual difficulties in deciding to enter shop work. The requirement that they wear unionalls as a matter of safety has kept many women from taking up the work. The men of the families have been most averse to seeing women don "men's clothes" and work amongst the men. As to the disgrace of wearing unionalls, those women in the shops cannot see that it is any more shameful to leave off hampering skirts while about machines than to leave off frills when going to the kitchen. Women wore aprons before the days of butchers and bakers and the latter are not regarded as any less manly because they wear clothing befitting the nature of their work. Articles of clothing were not created with sex, but they were devised as necessity demanded their use.

That the men in the shops do not consider the women beside them disgraced is shown by their respectful attitude toward them in the shops and on the streets. Not only do the men refrain from disrespectful remarks and actions in the presence of women, but they also give friendly and generous assistance when approached by them with inquiries about the work which is so foreign to their past experience. The fact that women begin with the same pay as do men and receive increases as they master the work has been an incentive to a better spirit between men and women. Many men who had objections to the introduction of women because they feared that it would lower their wages have withdrawn them since they find that these newcomers do not desire to under wage them. The presence of women has had a refining influence on the shop men. They are more careful of the language they use. The men working near a woman are always careful to take their bites of tobacco when her back is toward them.

Adequate provisions have been made for the comfort of the women workers. Even before stools were made for them one woman was permitted to use a box as a seat. Another was told by her foreman to sit on the end of her lathe bed whenever possible. A retiring room has been well furnished for their convenience and comfort. They are not, however, permitted to wear gloves to protect their hands for these are regarded as cumbersome and dangerous.

The women have proved that their talents are as varied as are the demands on their resources. One began work on the grinder and was soon transferred to the electric welding room where she is learning this type of work. Another commenced work on the grinder and is now doing piece work on the drill press. Still another was passed from grinding drills to running a shaper and later a lathe and has made a success of each. Two women are successfully operating milling machines, one is threading bolts, still another is working on a planer, and several are engaged in running cranes. So we see that woman's ability is not confined to operating any one type of machine, but she is able to adapt herself to the demands of the situation.

In quantity of work turned out the women are not yet equal to the men. Several have been put on piece-work, but, while they are making more money than they did on day work, none is as yet making as much as the man beside her. This delayed progress is in part due to reluctance to ask assistance in heavy lifting, which is generously given. The lesser quantity of work is to be expected, for until they entered the shops a few months ago women have been discouraged whenever they have shown any interest in things mechanical. Not many men are given the opportunity to try piece-work until they have had considerable more mechanical experience than the women have thus far had, so a comparison of output can not yet be made on a fair basis. In accuracy of work the women are pronounced easily equal or superior to the men. About the second week one woman was working on the lathe her foreman pronounced a dowel-pin she had made to be accurate within a half thousandth of an inch.

As one would expect, women have not yet shown any startling degree of ingenuity. They have been too busy mastering the problems so new to them to give much thought to improvements. That this power is latent is indicated nevertheless by a few cases, for instance, her reticence about asking to have her heavy chuck lifted for her caused one woman to ask for a board that she might lay from the lathe bed to the tool rack so that she might roll the chuck back and forth. As women become more familiar with the work they will doubtless show more ingenuity.

Lack of experience in men's way of working is women's chief obstacle now. The dismissal of two women who were irregular in attendance procured the desired result in added diligence on the part of a few others who were inclined to absent themselves from work frequently. They have learned to begin and close working hours promptly. There is every evidence to lead one to conclude that the women in the shops will unite with the men for the improvement of conditions. They will learn to discriminate between vital and insignificant details.

Women need no longer hesitate to enter the shops because of fear of inability. Nor need they hesitate to train themselves in this field. The foremen agree that "education counts," whether the laborer be man or woman. The woman with ability is placed in an unusually advantageous position. Her recent entrance into the field and the small percentage of women in the shop force make her conspicuous. The men give her all the respect she shows herself worthy of receiving. The nation needs the assistance of women in the shops. Even after the war closes there will be an increasing demand for woman's service to replace the man power rebuilding the war tattered fields of Europe.

THE MECHANICAL ENGINEER

GENERAL
MANAGER

"If the men bearing this title have not that kind of stuff in them then the railroads employing them need other men for their positions"



THE following brief articles were contributed by a number of mechanical engineers in response to the inquiry: "How can the mechanical engineer make his efforts of the greatest possible value to his road in the present emergency?" They present a number of interesting comments on the problems the mechanical engineer has to face, and in them is the suggestion of an ideal conception of the functions of the mechanical engineer in the railway organization which is worthy of the thoughtful consideration of all railway officers.

Although it must be admitted that this ideal has seldom been attained, there is no real cause for discouragement in that fact. If these men will but preserve it and keep it ever uppermost in their own consciousness—then conduct themselves as if its attainment were an everyday occurrence—the time will come when it will be a fact. It must be remembered that organizations shape themselves more or less in conformity with the human material of which they are made.

DON'T BE LIMITED BY A LABEL

Emergency is the parent of opportunity. There was never a time when the opportunities of mechanical engineers were greater or more numerous.

This is an age of engineering, and there is hardly any line of business, to say nothing of technical engineering, that is not to a very large extent mechanical engineering. Unfortunately employers have been too prone to look upon their mechanical engineers as special machines designed for special purposes, rarely thinking they were good for anything else, and more unfortunately, mechanical engineers have let employers "slip it over" on them.

These are critical times of great stress, both moral and physical, and we all hope that they presage the dawn of a new era, an era when men will go forward on broad lines instead of in grooves, when employers and employees will give more attention to analysis of the work at hand, themselves and each other, than to the titles which they bear.

Getting the most value from mechanical engineers is a matter of fullest co-operation of mechanical engineers and their employers. The business at hand at the present time is big and it must be handled in a big way.

Mechanical engineers, equipped as they should be with an analytical training, experience, loyalty and steadfastness of purpose, must eliminate personality and prejudice, do their work and carefully assert themselves with all their might. They must make their employers understand that they are willing to tackle anything and make good, and that their sphere of usefulness is not confined to the limits commonly associated with the label that has been applied to them.

The employers, to a greater extent than heretofore, must co-operate by broader recognition and selection of their mechanical engineers to fill positions of trust and responsibility in any of their departments.

If they will make a start in this direction, they will obtain results that will surprise them and will open the way for the advancement of a large class of most deserving and patient men.

The government moulds generals out of ribbon counter clerks. Railroads mould mechanical superintendents out of cinder pit laborers and engine wipers, presidents and general

GENERALLY speaking the railroads are getting far less than the highest services obtainable from the mechanical engineers and their organizations.

The reason for this is two-fold:

First.—Lack of vision on the part of the railway managements, of the possibilities of real engineering methods applied to the problems of equipment design, construction and maintenance.

Second.—Too much emphasis on the *Mechanical* and not enough emphasis on the *Engineer*, on the part of the mechanical engineers themselves.

If the mechanical engineer will but clear his own view of his job and its possibilities, then attack the problem with determination, who is better fitted to broaden the vision of the management than he?

The managements are "from Missouri"; engineers are by training especially fitted to do the "showing."

managers out of water boys. Why not presidents and general managers out of mechanical engineers, men who are especially trained to analyze; and after all, analysis is what "does the trick." If the men bearing the title of mechanical engineers have not that kind of stuff in them, then the railroads employing them need other men for their positions.

Summing all this up in a sentence: Mechanical engineers can do the most in this crisis by broadening their fields and by receiving full co-operation in that direction from their employers.

HONESTY, THOROUGHNESS AND DETERMINATION

In order to be of the greatest value to his company, the railroad mechanical engineer should bear in mind the following conditions:

First.—In the highest sense his department is purely one of service. He should form the connecting link between the manufacturer and his company, the purchaser. This implies a spirit of absolute fairness supported by strict honesty of opinion.

Second.—Certainly he should be most careful in making recommendations to see that they are backed up by convincing evidence, both as to operating results and the engineering fundamentals, so that there may be no recourse but to adopt a program once suggested by him. This involves a sound knowledge of economics and requires earnest and untiring effort.

Third.—He should be most determined and he should co-operate with every department concerned in any matter under consideration, representing the best opinion of the mechanical department based on the experience of all its members.

If the mechanical engineer is strong, earnest and clear thinking, his department will be respected and his judgment will inspire the confidence of those who are not engineers. His especial purpose should be to convince, not only his immediate superior, but the executives as a whole that the truth is being sought in every field and that special effort is being put forth, not only to take into account the mechanical limitations, but also the broader questions of cost of operation and capital expenditure.

GIVE THE MECHANICAL ENGINEER UNQUALIFIED SUPPORT

There are well defined laws of science and applied mechanics that have not been followed in building equipment, of which our repair tracks and repair shops hold an abundance of proof. This did not seriously hamper railroads as long as they had a surplus of equipment but since the supreme test of a war involving the civilized world has come, creating demands on our equipment greatly in excess of anything in the history of railroading, these conditions stand out much more sharply, especially so because the railroads cannot purchase new equipment or sufficient material to provide themselves with a comfortable margin in excess of the demands.

The mechanical engineer must therefore face the problem of bringing old equipment up to the highest possible state of efficiency at a minimum of expense and at the same time must plan for future equipment that will *stay in service* and involve a minimum of expenditure for repairs.

The present condition of equipment has been brought about by:

1. The large number of appliances which have come upon the market with good talking points but without the ability to hold out in actual service.

2. The narrow policy of roads in designing and purchasing equipment to meet only the service conditions of their own roads, and in some instances not even that, without taking into consideration that their equipment must go where much heavier service is required.

3. The pressure of a fixed limit of first cost brought to bear on the consideration of many points in construction and in the selection of appliances.

These are conditions that we cannot escape. How, in the face of them, can the mechanical engineer make his efforts of the greatest possible value to his road in the present emergency?

The mechanical engineer must be given the unqualified support of his superiors on all recommendations in which he is right. He should not be over-ruled in his decisions on construction and the worth of appurtenances unless he can be given a clean-cut and valid reason that such action is for the best interests of the road. When he is over-ruled he should always be given the opportunity to verify the decision against him and a right to appeal if he can show that he is right.

Specifications and plans should not be changed without his knowledge or consent. Changing specifications and plans to reduce the first cost should never be resorted to if it weakens the construction to a point below the recommended practices of the M. M. and M. C. B. Association. Such errors have been one of the chief factors in excessive repair costs and loss of service.

He should be conversant with all the rules and regulations that affect equipment, and should work with other mechanical engineers to bring about the best standards possible. He should take an active part on the floor of the M. M. and M. C. B. conventions.

In altering designs to cure failures he should make it his business to get all the facts as to the cause of the failures. It often happens that he is called upon to make unnecessary changes as the failure has resulted from some outside cause having nothing to do with the design.

In designing new equipment he should make every pound of material perform the greatest possible service, owing to its excessive cost and the difficulty with which it is obtained. One of the most noticeable failures in this connection is seen in the design of heavy freight locomotives, carrying 15 to 25 tons of metal around in the shape of trailing trucks that is contributing nothing to the adhesive weight; an exception is seen in the decapod locomotive recently built by the Pennsylvania Railroad. Another item that should have special attention is the center and draft sills of freight cars to see that the construction is as heavy or heavier than that which has been recommended by the Master Car Builders' Association.

In these two items alone there is an unlimited field for improvement. He should spend considerable time on the road, in the shops and on the repair tracks to learn first hand how designs and specifications can be changed to reduce repairs and all unnecessary labor expended in making them. This practice should extend occasionally to foreign roads and manufacturing shops.

Every man on the staff should be a mechanical engineer in the process of making and if possible a mechanic. They should be sent out on the road at least once a month to keep them from becoming machines that will eventually become a liability instead of an asset. They should be encouraged to take the initiative, talk to enginemen, trainmen and repairmen to obtain ideas for the betterment of the equipment. Getting out on the road means more than riding on trains; it is to enable them to relieve the mechanical engineer of many petty decisions that they ought to make for themselves.

The greatest asset the mechanical engineer can have is a determination to conquer and a cheerful disposition that never accepts defeat.

MAKE ALTERATIONS ONLY FOR IMMEDIATE UTILITY

The mechanical engineer's chief concern at the present time is to keep his organization intact, and thereby efficient. Various influences, including the draft, voluntary enlist-

ments, and the sudden increase in the wage scale of draftsmen due to competition from outside sources, has made it very difficult, indeed, to keep our good men with us. Owing to such conditions, the writer has lost a large proportion of his original force, making it necessary to rebuild it at the expense of great effort.

During the present emergency the mechanical engineer should refrain as largely as possible from instituting extensive tests of equipment or materials, as this class of work at this time would tend to interfere with the maximum output of transportation effort.

At the present time the mechanical engineer should keep in close touch with the shopping of equipment, particularly locomotives, making all possible effort toward introducing the small correctives in poor designs, which will not delay the output of the shops, but tend to keep engines and other equipment in service longer after they are out. He should hesitate to introduce any changes in design, unless they are very carefully considered from the standpoint of immediate and necessary utility.

REHABILITATE THE OLD EQUIPMENT

The mechanical engineer's efforts, in order to be thorough and comprehensive, must be continuous. His work, when rightly handled, is less of the routine type and more of the constructive kind. If he is really to be successful in his efforts, he must continue them over long periods of time and not over years or months only. He has duties, which, if properly discharged, must be performed under continuous heavy pressure. These, in a measure, are the reasons why I often wonder that railroad managers fail to recognize the importance of their mechanical engineers.

They are also the reasons why railroad mechanical engineers seldom perform spectacular feats or develop exceptional ideas that bring them into public prominence. Their best work is a gradual constructive piling up of idea on idea, plan on plan, to ultimate completion. Many of the best mechanical accomplishments in the railroad field are the result of this gradual development.

The mechanical engineer must by all means, even more than heretofore, assist his superior officer in solving difficult problems. He must help to make the burden lighter that railroad officers are carrying in keeping trains moving and shops producing increased outputs. He must assist in working out plans for quicker and shorter methods of making repairs for car and engine repairmen. He must seek to obtain stronger castings and better forgings on rolling stock, which may have been overlooked, underestimated or passed over in less serious times. He must, in addition to constructive thought of future equipment, concentrate more strenuously on present failures and weak spots than has ever been done before and eliminate every one of them that possibly can be eliminated. He must locate all types of material that are being purchased in the rough which can readily be furnished fabricated ready to apply; undoubtedly in times such as the present, the railroads should relieve themselves of every possible item of manufacturing work in order to increase their repair output. He must search carefully for any useless or unnecessary stock on fabricated material purchased by the railroad and see that it is removed on future orders.

He should concentrate more closely on what his railroad has, with which it is trying to operate, and not be concerned too deeply with future developments for equipment that is to be purchased after this great emergency has passed. Unquestionably the present time requires the operation of much equipment that would not be repaired in closely competitive years when operating costs are of serious consideration, and therefore the question of proper repairs and reinforcements to this type of equipment should be the mechanical engineer's most serious duty today.

He understands his old equipment and has the best op-

portunity to recommend betterments. His is the half way station between the shop men, possessed of good ideas, and the head of the department who wants these new ideas. A car or a locomotive that will haul or pull a load if properly reinforced or improved is a valuable piece of rolling stock today and, when we consider the present emergency condition, is so valuable that the mechanical engineer can well afford to assist in keeping every piece in service. The mechanical engineer truly can help and is helping and I am sure his efforts are being felt wherever they are thoroughly understood.

FIRING UP LOCOMOTIVES*

BY ALLEN ARMER
General Foreman, Big Four, Columbus, Ohio

The coal that is used in this locality is bituminous, coming from the fields of West Virginia, Indiana and Illinois. From the results of the laboratory tests these coals are found to be very high in volatile matter, or excessive smoke producers. Harrisburg run of mine coal is used by our company at this time. The proximate analysis is as follows: Moisture, 4.85 per cent; fixed carbon, 50.50 per cent; volatile, 37.80 per cent, and ash, 6.85 per cent.

Anthracite or semi-smokeless coal is not available in this locality, and in order to minimize the smoke problem, it becomes necessary to direct our efforts toward the manner of building and handling the fire. Due to the different weather conditions from day to day, the smoke generated in building fires in the roundhouse is variable. The application of the brick arch has proved to be of great assistance in smoke elimination.

From a roundhouse foreman's standpoint, the largest and most important factor is the method of handling the operation. The operator must be thoroughly familiar with the results desired and should know how to handle the fire to obtain them. The fuel must be properly placed to allow the correct amount of air to pass through the grates and the bed of the fire. If there is not enough air introduced into the firebox the gases are driven off the coal containing a high percentage of carbon, thus causing dense smoke. If the supply of air is too great, the gases pass into the stack before combustion takes place.

We have tried various methods of building fires in locomotives to eliminate smoke as far as possible. The following method is the most successful.

The grates are covered with coal banked along the side sheets to a depth of approximately 15 in., and 20 in. at the door sheet, allowing the fuel to slope gradually toward the center. This leaves a light bed of fuel in the center for the proper admission of air. Dry shavings are then placed on top of the coal, and enough more coal added to keep the shavings in place when the blower is applied.

It is important to start the fire at the rear of the firebox, as the action of the blower will draw it ahead. To light the fire oily waste is dropped inside the door, and a light blower is at once used. The fire is allowed to burn until it is well started, and the draft is then gradually increased. In a short time, under ordinary conditions, the coal is ignited, and there is a good fire over the entire grate area. A strong blower is an important factor in reducing smoke.

If the coal is properly placed and of sufficient amount it will not be necessary to add more until the engine leaves the roundhouse, unless the boiler has been filled with cold water. This will give approximately 100 lb. steam with a boiler full of cold water in one hour and forty minutes. With the boiler full of hot water and no steam pressure, the engine can leave the house in one hour. With this manner of firing we do not get over a No. 2 smoke at any time if the blower is properly used.

*From a paper read before the annual convention of the Smoke Prevention Association.

TIPS FROM CHIEF CLERKS TO SUPPLYMEN



Help the Railroad Officer—
He Needs You,
But Conserve His Time

THE EDITOR received in the morning mail a few weeks ago a letter from the chief clerk to a master mechanic telling of the mistaken idea one supplyman had of how to do business in a railway office. The first impression was that the experience was an unusual one; the next thought that it might be well to check it up with the experience of other chief clerks. A dozen chief clerks to mechanical department officers were therefore asked for frank expressions as to their experiences. The letter which caused the discussion follows, as well as abstracts from several letters which were received from other chief clerks.

A BAD START

BY A MASTER MECHANIC'S
CHIEF CLERK

Recently a gentleman, well-dressed, entered a master mechanic's office in a more or less excited state, approached the chief clerk's desk, making inquiry for the master mechanic in the following manner: "I would like to see Mr. Jones."

The chief clerk, after realizing that he had a very excited mentality and uneducated mind to deal with, calmly replied by saying, "Mr. Jones is out in the plant and will probably return to the office about eleven o'clock."

The impatient reply was, "I can't wait until eleven o'clock, as I have got to see Mr. Jones right away. What kind of looking man is he, and I will go out to find him? Where had I better go to find him?"

The chief clerk had no idea of permitting him to go anywhere in the plant until he made himself known and the nature of his business. With the idea of allaying the man's impatience, and playing for time, the chief clerk remarked

that he would probably want a pass to go through the shop. "Oh, no, I don't need a pass, as I am an old railroad man and was once a master mechanic. I know all about a shop."

The chief clerk replied by saying that recent instructions had been issued not to permit any one in the shops without a pass, and, of course, a pass could not be furnished unless the visitor would give his name and state his business.

The reply came quickly, "My name is Jacobson, I was for a long time master mechanic of the Sussex division of the A X P Railway."

The chief clerk replied by saying, "I presume, Mr. Jacobson, you are not now employed by that railway."

"No, no, I am now with the Ozark Tool Co., and want to see the master mechanic, also to see your general foreman and tool room foreman, as we have a number of our tools on your road."

This was all the information the chief clerk needed to issue the pass, but it took digging to find out from the man his name and the nature of his business, without appearing abrupt or discourteous, because it was absolutely necessary to obtain the information before the man could be permitted to enter the plant. By having to dig this information out of the traveling man it took up practically thirty minutes of the chief clerk's time and delayed Mr. Jacobson in obtaining an interview with the proper officials.

The traveling man can save himself and chief clerks, or other clerks, when desiring permission to see railroad officers, a lot of trouble and time by the simple little method of presenting their cards or explaining their business immediately on entering offices.

A WISE railway supplyman studies to get the good will of the secretary, chief clerk or clerk whom he must first approach in asking for an interview. These men are usually in the confidence of their superiors and it is part of their duty to help conserve the time of these men and protect them from needless interruption. Courtesy and tact are, therefore, essential in dealing with the chief clerks.

In these days of heavy traffic and extraordinary demands on the motive power and car department officers it is more than ever necessary to conserve their time. The late L. R. Pomeroy used to say that he never visited a railway office unless he was "dead sure" he could leave something in the way of data or suggestion that would be of a distinct help to the officer. Supplymen should get the spirit of this and be as thoughtful and considerate as possible of the officers with whom they have to deal.

"OLD HEADS" TOO MUCH AT HOME

BY A MECHANICAL ENGINEER'S CHIEF CLERK

As a rule, I do not consider the railway supplymen thoughtless or inconsiderate. There are, of course, exceptions to all rules, but, taken as a whole, I doubt if any fair-minded jury would find the supplyman guilty on very many counts. This is not snap judgment, but an opinion based on an experience of eight years. I have noticed the exceptions are usually made up of "old heads" in the game; those who have been making the "rounds" for years and feel that a certain privilege should be accorded them in railway offices by reason of their seniority and long association.

The young, inexperienced man very seldom makes a break of this kind. He is careful as to his movements and only anxious to learn the "ropes" so that he may abide by the requirements of the individual offices he visits.

WHY NOT CULTIVATE CHIEF CLERKS?

But why shouldn't the supplyman be courteous, considerate and continually making an effort to cultivate the good will of chief clerks and others about the office? It is surely a part of his job; and in a way an investment for him. While being courteous to some lowly railroad clerk by a supplyman does not indicate that a lengthy order is forthcoming or that a seed has been sown by which one might sprout, the way is paved for smoother travel on his later trips.

CHIEF CLERK NOT AN ENTERTAINER

The traveling man should not consider it the duty of any chief clerk to entertain him while waiting his turn to be called into the private office. The clerk's duty ends when he has seen to it that the caller's card has been presented to the superior officer and an answer returned. The "peddler" should not insist on discussing yesterday's score, the Italians' successful stand against the German attack or other interesting subjects.

On the other hand, it is up to the chief clerk to see that any caller entering the office is given attention, whether he be a "peddler," book agent, life insurance agent, or what not. No one should be allowed to "cool his heels" until some self-important clerk stops his blatant dictation long enough to find what is wanted. It has been my observation that the more harmony you can create, the bigger your caliber. Such treatment by a clerk certainly does not improve his stock with the caller, or increase his popularity in any way.

VALUE OF SUPPLYMAN TO COME

BY A S. M. P.'S. CHIEF CLERK

So far as my knowledge goes, the relations between this office and the supply fraternity have always apparently been of the pleasantest. This, no doubt, comes about by the fact that in my early experience with the supply fraternity, our office organization was instructed very thoroughly as to the value to the railroad company of visits by supplymen; that to a great degree, the time they spent with us was not wholly of value to them, but to the railroad company; and that to a great degree, supply men were serving the railroad company as they were serving their employers. Therefore, they should be treated with the same courtesy that would be extended to railroad associates. We have found, naturally enough, that supplymen would at least meet us half way so far as courtesy and service are concerned, and in some cases, the benefits derived through their assistance, I am frank to say, have been not only desirable to the railroad, but beneficial as well.

It has always been our motto, that "More flies are caught with molasses than with vinegar," and it is my experience that similar sentiment prevails throughout the supply fraternity. If this condition were made a practice, there seems

to be no reason why it should not work out to the mutual benefit of the railroads and supply men.

THE BOTHERSOME SUPPLYMAN

BY A MECHANICAL DEPARTMENT CHIEF CLERK

The supplyman who does annoy me, is the one who comes into the office and stands around ostentatiously until waited upon, no matter how I may be occupied. Many times, while I am talking on the 'phone or have a stenographer sitting at my desk taking dictation, or perhaps while in conference with some one at my desk, a supplyman will walk into the office and, instead of sitting in the place provided for them, will stand conspicuously until waited upon. Some of them will stand, and wait, and wait.

I often feel like telling them, rather sharply, to sit down and wait a few minutes; but I have never had any words with them about it. It seems to me that all supplymen should understand, when they call at an office, that if the chief clerk is busy they should be seated and wait a few minutes until they can be waited upon.

However, I really do not have any criticisms to make, and as a rule I receive fairly good treatment from all supplymen; and, in return, I endeavor to treat them as I would like to be treated.

SHORT AND TO THE POINT

FROM AN EASTERN CHIEF CLERK

From my observation, courteous treatment from either side produces a like feeling on the opposite side.

MR. SUPPLYMAN, WHICH SYSTEM DO YOU FOLLOW?

BY THE BOSS'S SECRETARY

Which system do you use and what success do you have? "Here is my card. Shoot it in to the boss. Smoke this after lunch—my favorite brand. I'm in a hurry, so help me out, old sport!"

Or—

"I have something of interest for Mr. Blank, the superintendent of rolling stock, and I am very anxious to see him and will appreciate your assistance. Would you mind taking my card in to him?"

DON'T GET IN WRONG WITH THE SECRETARY

It is probable that the method of approach to the secretary is more responsible for the success or failure of the traveling salesman than any other one thing. You must first get by the secretary or your ability to sell your goods will be of no avail, for you must get an audience with the man who buys.

As a secretary to a mechanical department official on a large trunk line, I have given this problem more or less thought, and with the feeling that I may be able to bring about a better understanding between supplyman and secretary, I will offer my conclusions.

The successful salesman is reputed to be a "hale fellow well met," and the first instance mentioned above covers an individual who is all of that, plus. It is an exaggeration in every respect, and there are two great qualities (in my opinion, two very necessary ones) that are entirely missing: Courtesy and tact. If you had called a number of times before and had learned the characteristics of Mr. Secretary you would probably feel justified in addressing him in this way. It has been my experience that by way of introduction to the secretary, a great many salesmen use expressions similar to the first mentioned.

The secretary may not be an "old sport," and it is possible that he does not smoke, and isn't interested in your favorite brand. Speaking about smokes, let me tell you the way one leading mechanical department official looks upon the proffer of a cigar. I will use his own words: "These peddlers that try to get by through the offer of a cigar are

certainly following the wrong system." Until the cigar was offered the caller was a supplyman and not a peddler. Last, but not least, the secretary is human, and the first thought that strikes him is "I wonder who this guy thinks he is, and if he feels he can put it over me as easy as that?"

Now, take the business-like, courteous method employed by the second man. You immediately get the impression of a quiet, determined business man, one who you know if passed in will briefly offer his proposition, won't be "running off at the mouth," and will not take a minute more of the boss's time than is absolutely necessary. And further, he has placed himself on an equal footing with the secretary, which is of importance when considering the "human interest" feature.

Just place yourself in the secretary's position. The boss is very busy, and does not want to be interrupted very much this morning, and any interviews would have to be short ones. Two supplymen come in at the same moment, one being of the effervescent kind, and the second, of the solid, sincere kind: The boss has just said, "short interviews." Which one would you send in, and to which one would you suggest, "Try it again some day and I'll see what I can do for you."

Another instance: Mr. Secretary looks at his appointment sheet for the day and finds an interval of twenty or thirty minutes with nothing booked. The "talkative" one comes in and wants to "Go over the top." Mr. Secretary says to himself, "If I let this fellow in he will take up too much time, and will upset the program for the day"; and again, a suggestion to the supplyman to try again.

The foregoing refers to the supplyman who is making his first call.

AFTER THE FIRST CALL

If I were a supplyman and wanted to make a subsequent call, I should resort to the telephone and endeavor to make an engagement through the medium of the secretary, or better still would respectfully request the secretary to let me converse with the officer and try and make my own engagement (the personal or human contact again). I would briefly state my purpose for wanting to see him and assure him that I would only take up a few minutes of his time.

I should also endeavor to learn if the officer had just returned from an absence from the office or was contemplating going out on the road, as I would not press for an interview the day before nor the day after. (The officer is as anxious to keep up his work and must find time to carry it on.) Neither would I call on Saturday or Monday. Saturday is a short day and Monday one must get rid of Sunday's accumulations and get the program started for the week.

When dealing with the secretary, do not doubt him and figure that for personal reasons he won't pass you in. If you are suspicious of getting a "raw deal," and he learns of your suspicions, and finds you are trying to get by without him "fixing" it for you, you are liable to a little sharp practice.

"A BAD BREAK"

It is only last week that I received instructions early in the day that for the morning, at least, there were to be no interruptions, the previous day being given up largely to supplymen. My instructions covered phone conversations also, and only on company business was I to put the boss on the wire. He was checking over specifications on new equipment—a big as well as a tedious job.

I received a phone call about 8:45 A. M. from a representative of a large supply house. He first wanted to talk to the superintendent of rolling stock, and I courteously informed him this was impossible because of a conference. His second request was for an appointment that morning, to which I was forced to reply in the negative. Then he wanted to come in for an interview in the afternoon, and I told him that he might come down, but I could make no promise as to getting him in for the afternoon program had not yet been laid out. He hung up in a "huff," but between then and

noon called four times, making exactly the same requests and getting the same answers each time.

About 1:30 he came in and very gruffly requested an interview with the superintendent of car department, and I promptly passed him in, as that official was "entertaining" that afternoon. He lost not a moment to complain that I was indulging in sharp practice, and I am glad to say that I was immediately given an opportunity to repudiate his statement, as the superintendent of car department immediately called me in. Suffice to say, he didn't get in to see the superintendent of rolling stock, not because of his actions, but merely because it was impossible. He left a "sadder but wiser" man.

Now, if you were the secretary and this same party later on endeavored to get an interview, would you give him the benefit of the doubt?

DEALING WITH THE BIG BOSS

Well, anyway, you finally get by the bodyguard (secretary) and he is holding the door open for you to go in.

I believe you should be even more careful of your approach to the boss than to the secretary. You are now before the railroad representative that has the voice in the matter of accepting or rejecting your proposition.

By all means use courtesy and tact.

Greet him courteously, but not effusively.

Don't slap him on the back and tell him his old friend, so-and-so, was telling you what a good scout he was. (He might have been a good scout to his friend who was not trying to sell him something.)

Don't wait for the first opening to say, "That reminds me of a story I heard a few days ago." (The boss might have heard the story, or it might be too putrid for him; besides, stories require time in the telling.)

In other words, get right down to the purpose of your visit. Tell him in as few words as possible just what you have, its purpose, saving, etc. Be protected by models, prints and photos. Don't be too technical, as oftentimes the man you are talking to is a practical man without a technical education, and you will lose his interest by going "too deep."

Above all, be thoroughly familiar with your product. Don't let him ask a question you cannot answer. Your cock-sureness will be communicated to him, and your uncertainty will likewise be communicated to him.

Meet his arguments by going him one better, always remembering that you are talking to a man who has reached the apex in the mechanical profession on his road, and that you can't put over him any "wild-cat" statements or figures. As he would doubt you, so will he doubt your goods.

One of the most successful salesmen I know of has for his motto, "Don't knock the other fellow or his goods." He says, "I have something here as good as the other fellows, can give it to you just as cheap, and all I want is a share of the business," and he usually gets it. He is sure of himself in the first place, and sure of his product in the second.

Read the daily papers and keep up-to-date: The boss may feel in a mood to visit, and naturally the conversation will drift to current topics.

You want to leave some impression of yourself behind you; something that will instantly bring you to mind at a subsequent visit; something of your character. You want to be welcome on your next entrance, and the impression you make on your first visit will govern your future intercourse.

YES, BE PERSISTENT

I assume that supplymen reading this will come to the conclusion that they couldn't make a sale if they followed my suggestions, as I have not mentioned "persistence," the greatest factor in making a sale. In my estimation, a successful salesman is one who is chuck-full of persistence. Persistence, however, is truly a virtue until through persistence one becomes obnoxious.



LOCOMOTIVE MAINTENANCE PROBLEMS

THE exceptional conditions under which the railroads have been operating since the United States has been at war, have created new problems in every department. The special problems of locomotive maintenance which have thus been created have to do with the necessity for increasing the number of locomotives available for service, without the ability to supply the increased demand by purchasing new ones, and the obvious requirement that these locomotives be supplied in shape to develop their full capacity in the movement of tonnage. The special nature of the problems lies in the fact that these increasing demands must be met with depleted forces and in the face of a most difficult material market.

In the following paragraphs, contributed by a number of officers who have been dealing at first hand with these problems, are set forth some excellent ideas as to effective means of overcoming the handicaps under which maintenance work must be conducted.

SHOP SCHEDULING INCREASES OUTPUT

BY F. J. HARRISON

Superintendent Motive Power, Buffalo, Rochester & Pittsburgh, Du Bois, Pa.

The scheduling of engines through our shops is working a remarkable and wonderful change. During the month of November we put 23 engines through our Du Bois shop after receiving heavy repairs, and on Thanksgiving Day the shops were closed tight all day. We are endeavoring to build this output up to an engine a day or 26 engines for the 26 working days of the month. The November output is an increase of three or

four engines a month over previous output. It can readily be seen that the stores department is kept busy getting the material for the increased output and until such time as we have the use of two new shops we are erecting, one at East Salamanca and one at Rikers,

we will have to continue to give special attention to our organization, our engines and cars. The desired result can only be accomplished by close supervision and harmony among our officers.

We have been welding in flues for the past several years and are running them the full three-year limit. We have three engines in service that have fireboxes welded in, no rivets at all being used on the sheets, with which we have had wonderful success, and from December 1, 1917, will weld in all of our fire-boxes.

We are also assigning our engines, passenger, freight and switch, and are satisfied that this is going to make another big improvement. Some days we are dispatching 10 and 12 more engines than are owned by the company, on account quick service at our shops.

DO ONLY NECESSARY WORK

BY A. M. DARLOW
Assistant to President, Buffalo & Susquehanna, Buffalo, N. Y.

The number of locomotives in the shop can be reduced effectively by not tearing down and doing unnecessary work on locomotives. Every motive power man knows that when a locomotive is taken into the "back shop" for general repairs a lot of extra and perhaps unnecessary work is done to relieve the shop superintendent of any criticism.

It would be better to reduce the number of engines held in

HOW CAN locomotive shop output be increased and the time out of service for repairs be decreased when labor is scarce and material hard to get?

Shop scheduling has helped materially; so has the right kind of training of the unskilled men who replace some of the many skilled men lost by the railroads. Spare fireboxes have cut down the time of heavy back shop repairs.

The extensive use of scrap in many cases has saved the material situation, and also much money.

Welding in tubes and firebox seams has done much to eliminate boiler repairs and keep engines in service.

There is evidence that superheater repairs are being neglected. This leads to loss of capacity and waste of coal. It destroys the investment value of the superheater and should not be tolerated.

the shop for general repairs by not doing so much heavy work on all the locomotives that come into the shop, and the work could be done with the smaller forces available. In large shops where a traveling crane is available, it would be better to remove wheels, turn tires, crown out the driving boxes, apply new rod bushings, and a partial set of tubes. In small shops where only a drop pit is available, the main wheels should be dropped, the tires shifted or renewed, the rod bushings renewed, a partial set of flues renewed, that is, the engine should be given a roundhouse overhauling. This should be of such a nature that the locomotive may be kept in service for from three to six months longer.

At some terminals locomotives are awaiting shopping for necessary heavy repairs. Make room for them by keeping out of the shop engines that can be kept in service by giving them light shop or round house repairs. In this way more engines may be repaired and kept in service.

ENCOURAGE INITIATIVE

BY L. A. NORTH

Shop Superintendent, Illinois Central, Burnside, Ill.

One of the first requisites of the maintenance of equipment in such a condition that it can be worked to the very limit of its capacity is the use of material possessing strength and wearing qualities suitable to the demands that will be made upon it. Then secure good reliable workmanship in the erection of this material. Patch work is only a makeshift at any time and will be costly if practiced for any length of time.

We have found that by encouraging the employes of the different departments that the productive capacity of the shop has been increased. It is the practice to personally interview the various employes and encourage them to develop tools which will assist them in the performance of their duties. Some of the ideas developed by them have been a means of reducing their manual labor to a great extent, as well as a great benefit to the company.

It has been our practice where an employ makes a suggestion of this kind, to allow him to build and develop his idea, where possible to do so, furnishing him such assistance from the other departments as is necessary.

The foremen have also been encouraged to make suggestions for the re-locating of shop tools, in order to avoid any back handling or congestion in the movement of the work through the shop.

Shop tools have been re-located, new tools of greater capacity purchased, and new crane facilities installed. Furnaces, steam hammers and other equipment which made possible a quicker handling of work have been added. We have taken advantage of the oxy acetylene cutting and welding process as well as the electric and Thermit welding processes.

TRAIN THE NEW MEN

BY E. V. WILLIAMS

Superintendent Shops, Buffalo, Rochester & Pittsburg, Dubois, Pa.

Increasing productive capacity in the maintenance of equipment while not a particularly new subject even at this time, is still a matter requiring vastly more attention from supervising officers than ever before. We have lost a number of skilled men through the army draft and the allurements of manufacturing plants, and, in order to replace them, have had to take unskilled laborers and train them in the various departments. To do this we have enlisted the services of our apprentice instructor and the various foremen, with such gratifying results that, while not having been able wholly to make up the losses, we have so far been able to hold our own and in some cases to effect a slight increase in production.

We have impressed on the minds of our foremen and sub-

foremen the necessity of giving close attention to the conservation of material, with the result that many items which had always been made of new material are now made of second-hand or scrap material, or are fashioned out of an article discarded from some other job.

A close check on all requisitions for new material, to learn the reason for ordering it and the condition of the part to be replaced, and an effort to have a less costly material used when consistent with specifications, frequently results in the cancelling of requisitions.

The introduction of a system of scheduling engines through the shops, limiting the number of engines in the shop for repairs at one time, and an intelligent report to the shops of the work required on each engine before it is placed on the pit, has resulted in an increased output and has reduced the time that engines are out of service fifty per cent. The engines are delivered for service regularly throughout the month instead of being turned over for service in bunches.

The number of devices and tools for increasing production and decreasing costs, as well as simplifying operations, has increased wonderfully as a result of constant co-operation of the foremen and men. The creation of a new position, that of supervisor of tools and machinery, who devotes his entire time to the working out of such devices and the economical placing of machine tools to minimize cost of handling, is one of the most valuable moves that could be made.

The placing of miniature or sub-storerooms in various departments, where a stock of much used small articles is kept, reduces the time the men are away from their work; and the practice of the stores department of collecting all material orders and delivering material to selected central stations is another powerful factor in increasing production.

Last but not least, the bi-monthly staff meetings where a full and free discussion is had concerning all things connected with the shops, bringing to the attention of all the costs of various operations and interchanging views on each subject, taking up engine failure reports in detail, the causes, delays, costs of failures and results of investigations, reports of train movements, loading and tonnage, and all matters relating to the service in all branches, loading and unloading and prompt release of cars at company's terminals, not confining any subject to any particular department, and interesting all in the value of "head work" has wonderfully stimulated the entire organization with very gratifying results.

UTILIZE SCRAP MATERIAL

BY C. L. DICKERT

Superintendent Shops, Central of Georgia, Macon, Ga.

We did not realize fully what economy meant until we were forced to it through necessity, brought about by high price and scarcity of material. In normal times before the war, material prices were low and material plentiful and could be gotten from the manufacturers in thirty days or less after being ordered. Now deliveries, if promised at all, are from 12 to 24 months, with prices almost prohibitive. But the railroads must run; therefore it is necessary that they have material to keep their power in good condition to handle the business.

To meet these conditions, we are utilizing every piece of scrap material wherever it can be used, reclaiming worn and broken parts of locomotives and cars by acetylene and electric welding and rolling scrap material into round bars for bolts, reinforced concrete bars and other stock where round iron is required. All scrap car axles are drawn out in the smith shop for making coupler yokes, truck arch bars, draft keys, etc., no new material being purchased for these items. All carry irons and straps for draft gears are made from scrap coupler yokes. Old yokes are removed from couplers,

straightened out, cut to length and formed under a hydraulic press in the smith shop.

We have just completed building 100 40-ton, 40-ft. wooden stock cars at Macon shop. Second hand material or material developed from scrap was used for the couplers, coupler yokes, draft bolts, carry irons, straps, striking plates, brake cylinders, brake cylinder brackets, washers, brake beam safety bars, pull down rods, brake rods, push rods, pipe clamps and release rods. The axles, trucks, truck bolsters and couplers were taken from an accumulation caused by the destruction of condemned equipment for some time past. The collars on the axle journals were built up with the oxy-acetylene torch and then turned to M. C. B. standard.

Parts developed from scrap material and second-hand material used in connection with freight car repairs are numerous, and the locomotive department comes in for much reclaimed and second-hand material.

Piston rods are made from scrap car axles, where the make of the material is known; crank pins from scrap driving axles and knuckle and wrist pins from scrap piston rods and axles. Side rod bushings removed on account of wear where pins are worn are used when new pins are applied. All globe valves are sent in from the system to the Macon shop for repairs. Scrap brass, such as injector steam rams, dowel plugs removed from driving box brasses, etc., are used in making small brass parts. Scrap boiler tubes are used for making locomotive pilots, coal gates, punching cut washers and bracing steel coal car sides. Scrap boiler plate is used for rod liners, shoe and wedge liners and cut washers. All oil cans, hand lanterns, caboose lamps, engine water coolers, switch lamps, semaphore lamps, markers, etc., are sent to the tin shop, repaired and reissued. Old I-beam car body bolsters removed from condemned equipment are cut up with the acetylene torch; the center is used for striking plates on cars; the flanges are used for stiffening strips on steel dump car doors. All nuts are assorted from scrap, retapped and used on freight cars. All brake beams are straightened and new fittings applied where needed. Where brake beam or T- or I-beam shapes are too light for further-service, they are split in shears and used for brake beam safety bars. Cotton waste used for wiping coaches, shop machinery and locomotives, is washed and used over again, effecting a great saving. Frogs and switches are repaired and made new at a great saving, using new and relay rail. The packing for frogs is made from scrap, drop forged to shape for the different sections of rail. Clay and tamping picks have new ends put on and brought up to standard size. Spike mauls, cleavers and spike bars are reworked. All track wrenches are drop forged from old driving tires. Switch lugs are made from scrap boiler plate.

Locomotives for all classes of service—passenger, freight and switching—are being superheated and equipped with power reverse gears.

BUILD SPARE FIREBOXES

BY E. W. TAYLOR

Superintendent Motive Power, Missouri, Kansas & Texas, Denison, Texas

In the locomotive department the general repair shop should be organized to co-operate with the supply department in such a way that the locomotives receive repairs in the shortest time possible. The men should be encouraged to do good work and machine tools speeded up to their full capacities; labor saving devices should also be installed. It would seem that to expedite engines requiring new fireboxes, an extra gang of boilermakers be put on to build new back ends complete, so that when engines arrive at the shops, the old back end may be disconnected from the barrel at the throat and the new back end applied. Ordinarily the application of a new firebox requires holding an engine about six weeks, but by having back ends ready ahead this

work can be accomplished while the machinery is being overhauled, which takes about two weeks. By this method the railroads have about one month additional service from the engine.

Money spent for back shop facilities and for kinks developed in the shop is a good investment and should be encouraged by the officers.

The routing of work plays an important part in expediting repairs, and this should receive thought and action.

DON'T NEGLECT THE BOILER

BY E. W. YOUNG

General Boiler Inspector, Chicago, Milwaukee & St. Paul, Dubuque, Iowa

For keeping the locomotive boilers in the best of order with the least expense in these days of scarcity of the most necessary materials and labor, frequent and painstaking inspections, coupled with the old grandmother's proverb, "A stitch in time saves nine," comes as near to a satisfactory solution as anything that can be done.

A thorough and careful inspection at frequent intervals will lead to the discovery of slight defects which can be repaired at slight expense and be the means of avoiding heavy repairs later on. A patch on the boiler will save many dollars for new material that will have to be bought later if the trouble is not immediately attended to. Looking for and finding the little faults, and never overlooking them because they are too insignificant to justify remedying them, is a sure means of avoiding big troubles.

Inspect often, find and remedy the little irregularities as soon as they make their first appearance. Then large repairs will rarely be necessary. This will work for the greatest economy and give the most satisfactory service from the power.

KEEP BOILERS FROM NEEDING REPAIRS

BY GEORGE AUSTIN

General Boiler Inspector, Atchison, Topeka & Santa Fe, Topeka, Kans.

The sketch shows an experiment that so far shows very favorable results. It was tried as a means of reducing the accumulation of clinkers or honeycomb on the flues, which on some divisions is very troublesome. The engine on which this was tried has been in service since last July and reports are very favorable.

In this case an old tube sheet was used, that is, it was pretty well worn at the holes before the counter boring

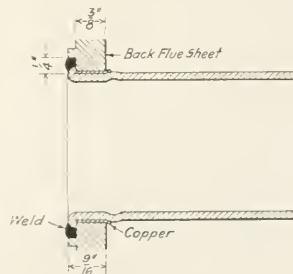

Method of Welding Tubes in the Firebox to Prevent Honeycombing

was done, it was then bored to 3 7/8 in. thick, copper ferrules were applied, and tubes swedged and expanded with a sectional expander for a 3 3/8 in. sheet. The tubes were then beaded and welded as shown.

In my judgment more good can be accomplished by educating the engine crews and engine handlers to prevent the necessity for repairs and by improvements in feed water

conditions and eliminating corrosion than by considering short cuts in making repairs.

I would rather find one way that will reduce or prevent the necessity for repairs than a dozen ways of improving the methods of making repairs.

ELECTRIC WELDING REDUCES BOILER REPAIRS

The Norfolk & Western for several years has been developing the use of electric welding in its boiler shop work. In 1914 a locomotive was placed in service with a welded firebox. The wrapper sheet was continuous and the flue sheet, door sheet and firedoor opening were all welded. No rivets were used except through the mud ring. The firebox corners were welded to the mud ring for a distance of about six inches around each corner and both the tubes and superheater flues were welded to the back tube sheet.

This locomotive has been in service for over three years, and during that time has not had a boiler failure. During the first year of this period the total cost of boiler maintenance was \$2.93.

All tubes on the Norfolk & Western are being safe-ended by electric butt welding, three machines doing all the work for the system, which operates nearly 1,000 locomotives. The work now done on one of these machines formerly required four coke fires and as many welders. In addition to the reduction in the cost of safe-ending, about two-thirds of the shop space formerly taken up by the four coke fires has been released for other use.

KEEP SUPERHEATER FLUES OPEN

In order that a locomotive boiler may evaporate water, it must be so constructed and maintained that the heat liberated in burning the fuel on the grates can be transmitted, with as little loss as possible, to the water in the boiler. The tubes are provided in the boiler for the purpose of carrying the hot gases given off from the fire, in the closest possible proximity to the water, so that rapid evaporation will take place. If the boiler tubes become stopped up from any cause, gases cannot pass through them. The result is, of course, a poor steaming engine which is unable effectively to haul its tonnage and causes delays, not only to its own train but to others, by stalling and having to double grades. In the case of the locomotive using saturated steam, plugged flues are bad enough, but in the superheater locomotive the conditions are aggravated because, not only does the lack of the necessary heat in the tubes cause a falling off in the amount of water evaporated into steam, but the steam itself, in passing through the superheater pipes, does not receive its share of the heat from the gases and consequently does not become superheated.

The superheater, as applied to a locomotive, materially increases the drawbar pull for each pound of coal burned. It follows, therefore, that if the superheater is shut off from the action of the hot gases by the large flues being plugged with cinders and soot, the locomotive is not going to show the performance which it should.

With the shortage of help in shops and roundhouses so acute as it is under present conditions, there is a tendency to let get by without attention those matters of maintenance and repairs which may seem the least important; but flue cleaning should not be classed among these. A locomotive may not be in the best condition as regards its machinery, and still it will give a good account of itself in getting the tonnage over the road if the boiler work is properly done, and particularly if the flues are thoroughly cleaned out and kept clean at all times. If the flues are kept clean in superheater locomotives the superheater can be depended on to live up to its effectiveness under the most severe conditions. In cleaning flues, it is not satisfactory to shove in a rod for two or three feet from the firebox end. The flues should be blown out thoroughly with compressed air, preferably at

a pressure of about 100 lb. per sq. in. If this work is done at the end of every trip, it will require a minimum amount of labor and will insure the flues remaining clean and the locomotive will always develop its maximum power.

THE IMPORTANCE OF SUPERHEATER MAINTENANCE

BY H. T. NOWELL

Assistant Superintendent Shops, Boston & Maine, North Billerica, Mass.

Many articles have been written on what should be done to properly maintain our locomotive superheaters and there probably is not a railroad man, in the mechanical department at least, who has not had the subject thoroughly drilled into him and has passed it on to the next in line. But do we maintain the superheater properly today with the excessive business that has been forced upon the locomotives? On many railroads, certainly not. Still we continue to expend thousands of dollars on new installations to old power and not a cent for the proper organization for supervision to see that those already installed are properly maintained.

The repair shops have certain well defined rules for the overhauling of the equipments, carried out while the locomotives are undergoing general repairs, that put the equipments in as good condition as when new. The engine houses also have rules which have been formulated from experience and careful tests that will give the best locomotive performance, but these are often neglected under the present severe operating requirements.

In talking recently with a man who has just completed a tour of many of the eastern roads, investigating the general superheater conditions, he said that the practices in the engine houses were not as good as they were three years ago, citing cases of plugged flues, locomotives fired with dampers tied up, and the general indifference to the importance of the whole subject, causing poor locomotive performance and damage to the equipments.

Conditions were better in the past when the superheaters were new. Engine house foremen were interested as it was a new subject; officers higher up kept it "alive," and employees having the direct care of the superheater engines gave them the necessary attention because they had been properly instructed. Since that time, these employees have gone "over there," or passed to other duties and the men filling their places have gradually drifted into wrong or indifferent practices.

Mechanical department officers are allowed thousands of dollars by their managements for new superheaters, as the argument is advanced to them that these equipments pay for themselves in a short time in the saving of fuel and increased hauling capacity, and this they do on the basis of the first few weeks' performance or when they are properly maintained. How much money are the mechanical department officers allowed per year to efficiently supervise the proper maintenance of these equipments?

We all know that the superheater locomotive boiler in poor condition is not as efficient as a saturated steam boiler that is in good condition, so it is doubtful if anywhere near the savings are made that are promised. Here is the condition of many superheater locomotives as they arrive at the shops for repairs:

1. Superheater damper wired up or fastened open. When put on the test rack, they are found to be working properly in nearly all cases.
2. Brick arch loaded with ashes and slag, plugging the lower flues. Appearances indicate that they have not been down for at least a month.
3. Half the superheater flues plugged solid so that flame from an open torch will not draw into the flue with the blower on. The result is that the ends of the nuts are badly burnt, also that the locomotive has not been getting the superheated steam, to secure which the management has invested \$2,000.

Complete instructions are issued with the superheater for its care and maintenance, but the problem will never be solved until the railroad managements put on enough supervision to see that these instructions are carried out to the

letter, along the same lines that they did when the Interstate Commerce Commission rules for the care and maintenance of locomotive boilers went into effect.

The most that the superheater company's inspectors can be expected to do is to report conditions as they find them. They certainly have not the time or the authority to investigate the causes of the intractions of the rules; neither do most of the engine house foremen have time with all their other duties to see that their instructions are carried out. In addition to this, the proper attention to the superheater sometimes prevents just what the engine house foreman is endeavoring to do—turn his locomotives in the least possible time. This he will do regardless of the superheater equipment unless there is a check placed upon him.

So, in these strenuous war times when everyone, even to householders, are endeavoring to save coal, we would urge the railroad managements to provide the necessary additional money to protect their investments and to carry out to a greater degree the purpose for which the superheater was designed.

MACHINES FOR MILLING PISTON RODS KEYWAYS

It is the practice in many shops to use end mills for cutting the slots for cross-head keys in piston rods. Since such tools cannot take a heavy cut this method is rather slow. To secure better output on this work a helical milling cutter is used at the Topeka shops of the Atchison, Topeka & Santa



Milling Slots for Crosshead Keys in Special Machine

Fe, and a special machine has also been developed recently which makes it possible to perform the entire operation at one setting.

The machine consists of a rigid base on which is mounted a standard for supporting the cutter and the air motor which drives it, and a carriage for feeding the work. The carriage, as shown in the drawing below, has a dovetailed slot to fit

the table and two V-blocks for holding the rods. The stand consists of two vertical rods, securely braced, with two cross pieces at the bottom for supporting the cutter and another near the top fitted with a feed screw and hand wheel for supporting the air motor. The spindle for the cutter carries a pulley which is belted to a larger pulley on a ver-

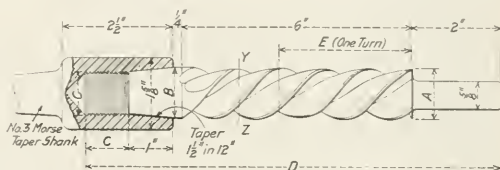

Size	A	B	C	D	E
3/8"	2 1/2"	3/2"	8"	2"	2 1/2"
1/2"	3 1/2"	3 3/4"	8"	2 1/2"	2 1/2"
5/8"	4 1/2"	4 3/4"	8"	3"	2 1/2"
7/8"	5 1/2"	5 3/4"	8"	3 1/2"	2 1/2"
1"	6 1/2"	6 3/4"	8"	4"	2 1/2"

Size	A	B	C	D	E
1"	7 1/2"	7 3/4"	8"	4 1/2"	3"
1 1/8"	8 1/2"	8 3/4"	8"	5 1/2"	3"
1 1/4"	9 1/2"	9 3/4"	8"	6 1/2"	3"
1 1/2"	10 1/2"	10 3/4"	8"	7 1/2"	3"
1 3/4"	11 1/2"	11 3/4"	8"	8 1/2"	3"



Milling Cutter Used for Milling Piston Rod Keyways

tical shaft, this shaft driving the feed screw through a worm and wheel.

In operating the machine the piston rod is first clamped in the V-block and a drill of a size equal to the width of the keyway to be cut, is placed through the bearing in the cross seat, a bushing being provided to hold it central. The air motor is then attached and the hole is drilled through the rod at the end of the keyway. The bearings for the cutter must be in line with the centers of the V-blocks to insure

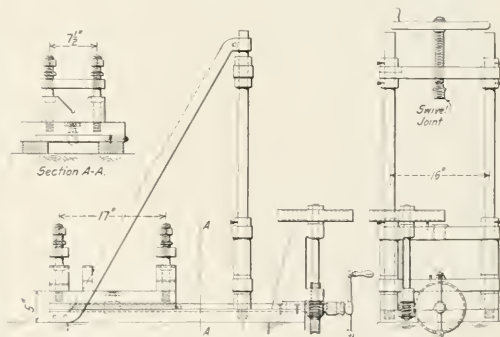

General Arrangement of Keyway Milling Machine

that the keyway will be in the exact center of the rod. After the rod has been drilled a milling cutter is inserted in the hole, the pulley and spindle are put in place and the remainder of the keyway is milled out. A helical cutter of the type illustrated is essential for rapid work in the milling of these slots.

RAILROAD CONSCRIPT.—The New York Sun in a despatch from Oklahoma City tells of the first United States railroad conscript. Gibson Carson, a Grady county school teacher, who is of draft age, asked the local exemption board to be assigned to work which would aid the government and by which he could better support his wife and child, saying that he would be willing to fire a locomotive on the Frisco. Mr. Carson's plea was honored by the board, and he started in firing "Ole Betsey," claimed to be the crankiest locomotive on the Frisco at that point. The exemption board says it has authority to assign a draftee to this form of national service, as the railroads now are in charge of the government.

PAINTERS MUST PROTECT EQUIPMENT

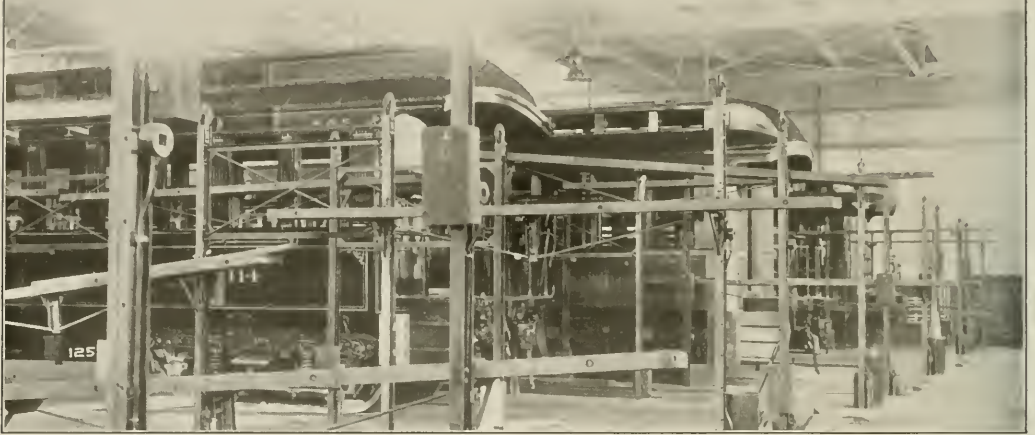

THE PROBLEMS of the railway equipment painters are no less serious than those of other craftsmen in the mechanical department. Their duty is to protect the equipment and still keep it out of service as little time as possible. The following suggestions for conserving material, labor and time were received from prominent men in this particular field:

PAINT ONLY FOR PRESERVATION

BY J. D. WRIGHT
General Foreman Painter, Baltimore & Ohio, Baltimore, Md.

One of the biggest problems confronting the railway painters under present conditions is to get hold of the equipment to paint, as it is in such great demand. And when it is laid up for repairs on account of accident, unsafe condition, or being unfit for service for other reasons, it is hard to get sufficient time in which to paint it properly on account of the unusual demands. The equipment is wanted in service, paint or no paint.

The painting problems are insignificant when compared with the big problem confronting not only the railroad companies and their employees, but the entire country as well,—that of bringing the war to a successful conclusion. And we appear to have already almost reached the point when everything which does not contribute to this end will be considered a secondary matter.

With this in mind it seems reasonable to expect that the painting of railroad equipment will suffer, temporarily at least, while practically all our energies are directed towards

winning the war. During this period, which we hope will be short, safety and movement of equipment are more essential than anything contributing only to their appearance, so it seems desirable to get down to the most practical methods of painting and do that which is absolutely necessary.

Under present conditions, the painting should be done mainly for preservation, especially on steel equipment, and as rapidly as consistent, with a view to keeping the cars and locomotives in service as much as possible whenever they are needed. This will conserve both labor and material and in this way contribute to the success of the railroads and also the country at large during these unusual times.

PROTECT EQUIPMENT BUT KEEP IT MOVING

BY J. E. ROSS
Master Painter, Gull, Mobile & Northern, Mobile, Ala

The three great problems confronting the master painter today are the almost prohibitive cost of materials, the scarcity of skilled labor and the need of equipment in service. In seeking means to adjust to and minimize these conditions, more than the ordinary amount of care and study should be given to the economical handling of all

work coming under the jurisdiction of the painter, and close judgment with a leaning toward the radical should be exercised in determining the amount of work that should be done and arranging the work schedule, for here the foundation is laid on which depends whether the saving desired in material, time and effort is real or just imaginary.

PRESERVATION—not appearance—is the watchword of the railway painter today. With a shortage of labor and materials and a material increase in the price of both, coupled with the extreme demand for the equipment in active service, the painter is “between the devil and the deep sea.” He must, however, protect the cars and locomotives from rust and decay. He knows better than anyone else what the lack of proper protection means in the deterioration of the equipment and should not permit its being overlooked. His part in the maintenance of equipment, and particularly the steel equipment, is a most important one. With a shortage of labor and the lack of time, the past practices of painting will of necessity be changed. The various writers on this subject give suggestions as to what can be done. The use of enamel colors and paint sprayers are particularly mentioned as methods that save considerable time.

A reduction of the amount of material used by cutting down the number of coats, thus saving both material and labor and giving a shorter shop schedule is to my mind the only means of solving the problems if equipment is to be shopped at all. Cutting the number of coats means a revision of shop standards, of methods and quality where the latter means an extra coat or an extra rub to further improve a surface already sufficiently good to clean and wipe down which is the real essential.

All exterior decoration should be discontinued by not re-decorating or striping when necessary to cover up or remove old surface as must be done in extreme cases. The old surfaces should be patched with primer and putty. The removal of old paint by burning or by the use of solvents should be an extreme exception, as, beside the additional labor involved in either case, in the latter, potash and acetone are among the most needed war materials.

The master painter must remember that equipment must be kept moving and not allowed to deteriorate or depreciate for the need of minor repairs and protection from the elements. The maximum of service with a minimum of effort and material costs is the result required and which should be sought. Trade precedents and customs, trade rules and ethics must all give way to the new system during the present need.

CONSERVATION OF LABOR IN THE PAINT SHOP

BY J. H. PITARD

Master Painter, Mobile & Ohio, Whistler, Ala.

The shortage of labor has not seriously affected the paint department yet, due to the fact that in some cases the unusual demand for freight and passenger equipment has drained the shops of cars and thereby caused a scarcity of work. However, it is obvious that equipment, if held in service beyond the usual shopping period will require more extensive repairs when it returns. To the paint department, this means that more passenger cars must undergo the burning off process, which is the heaviest class of paint repairs, and of course requires the maximum of labor to handle it.

The problem of devising means for maintaining the painting of equipment in an unimpaired condition will cause much concern for every master painter. Many roads have previously adopted enamel colors in lieu of varnish for the exterior finish of passenger cars, and also to a limited extent for the interior, using enamel colors also for lettering and striping. By this method the two coats of flat color is eliminated, thus effecting a saving of several dollars on each car, and also effecting a saving of one or two days of the time that a car is usually detained in the shop. This method produces fairly good results when the highest grade enamels are used, and for those shops that are still using the flat color and varnish method, it doubtless offers to some extent a solution of the labor shortage problem when that time arrives.

This method also applies in the painting of locomotives. When the surfacing is completed and the job is ready for the color coats, a space large enough to receive the lettering is painted with flat color, and the lettering is applied and when dry the letters and entire space is varnished, and then the remaining surface is coated with varnish color. This method expedites the work, and if handled properly, makes a satisfactory job. The methods mentioned above have been found quite satisfactory in short cutting the work and also in reducing the cost. But so far as the finished appearance of the work is concerned, it does not quite compare with the flat color and varnish method.

In painting freight equipment, the solution of the problem of labor shortage is the paint sprayer. With a good sprayer, an operator and a helper should paint from 15 to 20 cars per day of eight hours. The sprayer consists of a portable tank holding about 30 gallons, a single hose, 60 feet long,

to the end of which is attached a seven foot $\frac{3}{4}$ -in. pipe with a nozzle and cut off valve. With this outfit, the largest car can be coated in from 15 to 20 minutes.

POSSIBILITIES FOR REDUCING PAINTING COSTS

BY B. E. MILLER

Master Painter, Delaware, Lackawanna & Western, Kingsland, N. J.

The following are my views as to possible curtailment in the expense of painting cars and locomotives:

Passenger Cars.—A reasonable amount of surfacing or smoothing-up should be done on passenger cars as otherwise cleaning and wiping cannot be carried on successfully. Where appearances are to be disregarded entirely, but little money need be spent for puttying and levelling up uneven or defective parts.

Most railroads have already dispensed with all striping and decorations on the exterior of passenger cars. On a number of railroads the use of varnish on exteriors of passenger cars has been discontinued and varnish colors or so-called enamels are being applied. This means a considerable saving as to both time and material. The surface produced is not equal in appearance and lustre to one which has been varnished, but is a fair substitute. It may be cleaned up acceptably at terminals and wearing properties are about equal to a varnished job.

Little may be expected in the way of additional economy on interiors of passenger cars. Most of these are now finished in natural wood or grained to imitate the wood and in some instances the surfaces are enameled, suitable combinations of colors being employed. It is quite unlikely that the discriminating taste of the public would for a while at least be disregarded by substituting something inferior and less pleasing. Sanitary conditions, too, have to be reckoned with and cleaning must be made comparatively easy and economical. Plain painting with oil colors could, of course, be substituted for the varnished or enameled finish should such a step in the direction of economy become unavoidable; for sanitary reasons, however, we would consider this impractical.

Locomotives.—On most railroads, it would appear, that the limit of plainness and economy has about been reached in painting locomotives. Striping and other gold-leaf ornamentations have been discontinued, the Lackawanna having received orders to that effect only a few weeks ago. The use of varnish may be dispensed with and replaced by varnish colors or locomotive finish black. On a great many roads this has already been done for a number of years. Cheaper materials such as are used on freight cars cannot very well be substituted as these cannot be cleaned and wiped successfully.

Freight Cars.—Very little may be said in the way of recommending a less expensive method to be followed, as the cheapest labor and the most economical materials are, generally speaking, employed for freight car painting. The use of special colors—reds, greens, etc., on special service cars, such as cabooses, refrigerators, line cars, etc., may be discontinued and ordinary freight car paint applied. The use of badges, trade-marks or other stenciling on freight cars, of a purely advertising nature, might be dispensed with if deemed advisable. Except for appearances as to wooden cars and the necessity of protecting steel equipment against corrosion, the painting of freight cars might be discontinued entirely for a period of time if appearances may be disregarded. All stenciling and necessary marking would naturally always have to be applied.

The conservation of labor in the paint department must be accomplished by the substitution of cheaper methods and the discontinuance of unnecessary operations or those not absolutely essential to safety. Among the latter may be classed the cleaning of cars, exterior and interior, or such portions thereof as will not conflict with sanitary regulations

and endanger the health of patrons, as well as the cleaning of locomotives.

Many paint shop operations could be taken care of by women and eventually it may become necessary to make use of them where practical.

CUTTING DOWN THE PAINTING EXPENSE

BY CHARLES E. COPP
Foreman Painter, Boston & Maine, Billerica, Mass.

The high cost of living has hit everybody and has found in the railroads a shining mark, and the end evidently is not yet. We must all say and *do* all we can to help the struggling roads over and through this hard epoch in their history.

The painting departments of most roads, and the Master Car and Locomotive Painters' Association in particular, has done its part toward the reduction of the cost of painting cars and locomotives. In 1875, Robert McKeon, secretary of the above association at that time, said: "A first-class day railway coach on any of our main roads costs, when complete, about \$6,000. To protect this work the painter expends from \$300 to \$600. Twelve weeks should be the time allowed to paint a car." Mr. McKeon gave some good advice here, but if he had lived to see this day in some, if not most of our shops, he would have seen the time required to paint a passenger coach cut down seventy-five per cent below those figures, if not more, and *still going down!* And still the cost of the railway coach has greatly increased over those figures. However, I am not here citing the increased cost of the building of the car of today as any reason why we may not look for ways to even further reduce the cost of finishing them in the paint shop, if possible, and I have little doubt but that this can be done without serious detriment to the equipment of some roads.

Whatever is plain, whether inside or out, can be repainted and varnished oftener and, therefore, the general appearance is much better. Some roads are still without justifiable reason painting their car exteriors with all the striping, etc., just as they did 30 or 40 years ago. Material is constantly being piled up on cars that can be reduced in quantity by reducing coatings that can be abolished. Passenger car floors are being loaded down with two coats or more of paint annually, which is worn off only in the aisles and between the seats, when one coat of flat-drying material, to give an even appearance to the floor, and sweeten up its sanitary condition to start it off in service, is all that is needed. The floor that will not wear off quickly is one made of cement with a trowel, instead of paint with a brush. Half as much or less interior varnishing as some are doing will load up the finish less with grime and material to crack. Rubbing up after washing with a suitable non-drying renovator oil is enough for many cars that have been varnished the previous year or two.

Less gold-leaf and more gold-colored paint letters should be used. The Boston & Maine made the latter the standard years ago for all baggage, mail, milk and express cars and is extending its use largely on second-class passenger carrying cars. Much needless sandpapering can be omitted on luggage carrying cars without detriment to equipment. One coat of body color and one coat of varnish can be dispensed with on all painted cars by uniting the second coat of color and the first coat of varnish in a durable body enamel for all cars where the paint letters are to be applied. This has been practiced by the Boston & Maine with good results for several years.

Probably much car washing can be omitted by painting some "storage" equipment little used without washing, including inside of baggage and similar cars that are in suitable condition. And doubtless many other ways can be devised to save labor and material, but each road with its own peculiar service and needs has to be its own judge in

these matters, and if they will look around sharply with the disposition to save if they can, they will find plenty of opportunities.

INTELLIGENT BUYING AND INTELLIGENT SUPERVISION

BY J. W. GIBBONS
Atchison, Topeka & Santa Fe, Topeka, Kan.

It is a well known fact that on very few railroads are the foremen painters consulted upon the purchase of materials used to protect the equipment. In other words, he is held responsible for results without a chance to demonstrate his ability to give results. If he is brave enough to suggest a certain grade of material, which he knows by experience would give satisfactory service, he is very liable to be suspected of having ulterior motives. The result has been that men higher up, who knew nothing about paint materials, have had control in the choice of materials, and have been easily imposed upon.

The unscrupulous manufacturer has been enabled to sell his worse than worthless materials to the railroads, because the only man who could check him up was afraid to do so. Is a painter less reliable than a machinist, a carpenter, or a clerk? Would anyone employ an editor or a lawyer to perform an operation for appendicitis?

Every man who has studied the question knows that improper cleaning of cars and locomotives has destroyed more paint and varnish than all other agencies combined. Now, that the very life of our country is at stake, are we going to continue in the same old rut and make the same old blunders?

I know that thousands of dollars can be saved in the painting and cleaning of cars and locomotives, and at the same time the general appearance of this class of equipment will be greatly improved if the work of painting and cleaning of paint and varnish of each railroad be placed under the supervision of a man who understands not only the proper methods to use in applying paint and varnish, but who also knows something of the nature of the materials of which they are composed, and the best methods of preserving them.

Books of Rules, outlining methods to be used, are good things, but unless followed up by a competent supervisor, very little attention is given them, and high grade cleaning materials are often worse than wasted because they were not properly handled.

The primary object in painting cars and locomotives is to protect them from rust and decay. In selecting paints to protect railroad equipment, the nature of the material to be painted and the service it is expected to render should be considered, and it should be thoroughly impressed upon the minds of the purchasing powers, that the substitution of cheap oils and pigments is wilful waste of both labor and material. The constant demand for man power is very apt to bring into vogue practices that have heretofore been considered too wasteful of material to warrant their general use on cars or locomotives. I speak now more particularly of devices to spray paint or varnish. It is an acknowledged fact that with a spray it requires from five to twenty per cent more material to secure the same thickness of paint film that can be obtained with the brush. It should also be borne in mind that, in the light of the information furnished by the Government itself, as to the injurious effects of the mist and fumes which arise from the materials when sprayed, their use would be unpatriotic, if not criminal, unless the shop was equipped to protect the operator from the poison vapors.

Intelligent supervision of the paint department, which should include the cleaning of equipment as well as the painting of it, can and will save thousands of dollars.

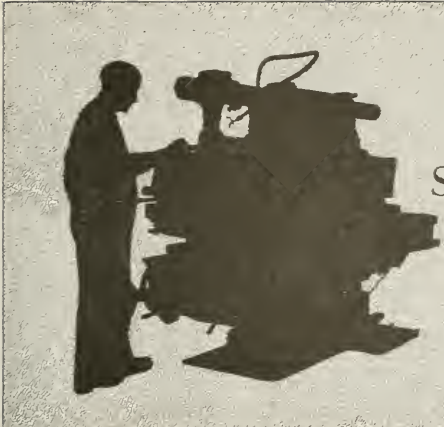

PLAIN KNEE TYPE AND SIMILAR MILLING MACHINES

Their Uses and Possibilities
in Railway Shops

BY M. H. WILLIAMS

SHOPS manufacturing machine tools, automobiles and various appliances for the market are going more and more into the use of milling machines. These machines are to some extent taking the place of planers, slotters and shapers. This change has been brought about by the increased economy and high grade of work possible with modern milling machines, and especially those of the knee type.

In machining locomotive parts such as rod keys, wedges and brasses, pedestal shoes and articles of a similar nature, the knee type of milling machine will prove a very economical machine tool, experience having shown that parts like those mentioned above can be made much quicker on the milling machine than on any other. There is, however, a limit for milling, and for light running repairs where only one piece is to be machined at a time, the milling machine cannot be recommended. The universal type of milling machine is now quite extensively employed in railway tool rooms and has proved very satisfactory for the smaller work. But as a rule it does not have sufficient strength and pulling power to quickly mill locomotive parts, where it is a question of removing metal at a rapid rate.

For the economical manufacture of locomotive and car parts, the largest types of plain milling machines will be found none too large for the first installation. As the work grows, smaller machines can often be used to good advantage in conjunction with the larger ones. With these larger knee type machines, a number of milling jobs now done on the planer type slab miller, can be finished very much quicker on account of greater ease of manipulation. This will relieve the more costly slab millers and in turn allow the planers to be employed on other work.

IMPROVEMENTS IN MILLING MACHINES

In the last few years a number of improvements have been made in the plain milling machine that have added to its adaptability for railway work, and the two more important of these are, greater power to drive cutters to the limit and quicker methods for changing speeds and feed, so that either can be readily adjusted for any particular article to be machined. This second improvement is especially valuable in railway work where a long run on one job cannot be expected on account of the comparatively few parts to be made at one time. The later machines are provided with necessary pumps for supplying a liberal amount of cooling compound, which insures keeping cutters and

work cool and adds very materially to the life of the cutters and the speed of production. The above and other improvements put the plain milling machine in a class that should receive careful consideration for future installations of machine tool equipment.

Cutting Speeds and Feeds.—With the slow speeds common on milling machines a few years ago, the time required to finish a given surface did not compare very favorably with the planer, but with the speeds now available, the milling machine has outclassed the planer for a large number of jobs. Present cutting speeds and feeds would have been considered out of the question a few years ago.

The following are illustrations of what has been done and what can be duplicated or exceeded in any railway shop having proper machines, cutters and methods:—the flat surfaces of rod keys made from .40 per cent carbon steel, 1 in. to 1½ in. wide, can be milled at cutting speeds of 40 ft. to 80 ft. per minute and feeds of 3 in. to 6 in. per minute; the rounded corners of rod keys are cut at feeds of 3 in. to 5 in. per minute, using concave cutters of suitable radius; flat surfaces like driving box wedges 6 in. wide, are cut about 3 16 in. deep at feeds of 2½ in. to 5 in. per minute; the flat surfaces of a rod key 12 in. long are milled in two to three minutes actual cutting time. This should be compared with the time required to finish similar articles on a planer or shaper on which these parts are now mostly finished.

With the speeds and feeds as mentioned above, it will be necessary to grind the cutter one or two times a day, the time required depending very largely on the amount of slag or seams in the steel or wrought iron being milled. Iron castings can generally be milled at greater speed than mentioned above but much will depend on the hardness of the iron and the smoothness of the surface demanded. Steel castings can be milled at about the same speed as low carbon steel forgings. However, the amount of sand burned into the casting will largely limit the speeds and life of the cutters.

Holding on Machine.—High speed milling makes it necessary to very securely hold the article to be milled, but the vise furnished as part of the machine is usually strong enough. The question of special holding fixtures would have to be worked out to suit local conditions, which would be governed largely by the number of articles to be made at one time. Articles to be machined can be clamped on the milling machine as quickly as on the planer or slotter,

and ordinarily the cost of holding fixtures for either class of tool would be about the same.

MILLING CUTTER IMPROVEMENTS

The improvements in milling cutters adapted for railway and other work have been quite remarkable in the last few years and have contributed greatly to the present success of milling. A description of what is now the most desirable cutter as compared with the older forms will be of interest, especially to those who have not given this question careful consideration.

The cutters of a few years ago had teeth spaced from $\frac{1}{4}$ to $\frac{3}{8}$ in. and many are in use today, the faces of the teeth being cut radial from the center. The teeth were generally cut straight or only slightly spiral and except on form cutters or gear cutters they were rarely ground on the cutting face. The belief was prevalent that fine teeth were necessary in order to obtain smooth surfaces but later investigations have shown, and it can be proved by an examination of milled surfaces, that there will be one depression



Fig. 1.

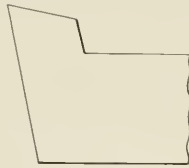

Fig. 2.

for each revolution of the cutter. If feeding 1/16 in. per revolution of cutter, the depressions will be 1/16 in. apart; $\frac{1}{8}$ in. feed, $\frac{1}{8}$ in. apart, etc., this showing that depressions are revolution marks and have no reference to the number of teeth in the cutter. Or in other words, a cutter of one tooth, 10 teeth or 40 teeth will cut practically to the same degree of smoothness when employing the same number of revolutions per minute and feeds, and worked within practical limits of milling.

The cutter now largely employed for flat surface milling, and which can be obtained from a number of concerns, has teeth spaced from 1 in. to $1\frac{1}{4}$ in. and cut on a spiral of about 25 deg., the face of the tooth being undercut or given a rake of from 7 to 10 deg., the cutting face and top of the teeth being ground after hardening. All sharp corners at the bottom of the tool are avoided. The above mentioned features are worthy of careful study, the object aimed at having been to design a cutter that will produce a satisfactory finish and have the maximum strength to cut and remove metal quickly with the least consumption of power.

In many respects what has been followed to be good practice with lathe tools has been followed in the design of cutter teeth. Generally speaking, a milling cutter may be likened to a number of lathe tools clamped in a circular holder and revolved. As a matter of fact some of the larger slabbing face mills are made up of a number of tools similar to lathe tools set and clamped into recesses in steel disks.

Let us compare the tooth of a modern milling cutter and a lathe tool.

Fig. 1 shows the form of tooth of a modern milling cutter and Fig. 2 shows a lathe tool ground according to modern practice for light cutting of wrought iron or steel. The similarity of the two is at once apparent. Note that the cutting face of the cutter tooth shows about 10 deg. rake, in order to properly curl or clear the chip, and follows lathe practice. The form of tooth is designed for strength and all sharp fillets are avoided to reduce the possibility of cracks when hardening. The face of the tooth is ground

after hardening to remove the chip without friction and for the same reason that the top of a lathe tool is ground. It would be considered very poor practice not to grind the top face of a lathe tool after hardening and the same applies to milling cutters. The question of grinding will be considered later. The spiral form of cutter, as well understood, has many advantages and it is a question just how great the spiral should be. Twenty-five degrees appears to be a happy medium. The effect of this spiral is that chips are peeled from end to end, and on wide surfaces two or more teeth are cutting at one time, and as a result the cutting is continuous. This reduces the chatter of the cutter and the hammering of the gears of the machine. Objection has been raised to this high degree of spiral on account of end thrust on machine spindle, but with reasonable limits, say 25 deg., the end thrust will not seriously affect the power consumption or wear of the machine.

Experience has shown that the coarse tooth cutters will mill a greater number of similar articles between grinding than the older form and admit of doing the work much quicker. This is accounted for largely by the design of the tooth, which peels off the metal in the form of a good husky chip in place of chips resembling iron filings, as generally follow with old cutters and methods. Compare the thickness of chip of two cutters of the same diameter, one having 10 teeth and one 40 teeth, and feeding, say 1/16 in. per revolution. Theoretically the 10-tooth cutter will remove chips .006 in. thick and the 40-tooth cutter one-fourth as thick, or .0015 in., the latter only amounting to a scrape. In actual practice when feeding this small amount per tooth, several teeth will glide over the work without cutting and the theory is advanced, which appears to be borne out in practice, that the teeth of cutters are dulled fully as much in glazing over the work as in cutting a reasonably large chip. Also the horsepower hours required to remove metal will be much greater where light chips are taken. Referring to Fig. 1, attention is called to the fact that the form of tooth has been designed for great strength, the removal of heavy chips and to withstand an accidental "hook in" to the metal being milled.

From all data available these coarse tooth, 25-deg. spiral, undercut, ground face cutters will remove the same amount of metal as the older form, with 25 per cent less power, and when properly used with a large supply of cooling compound, milling is now done at from two to six times the old rate.

Diameter of Slabbing Cutters.—Small diameter cutters are generally recommended for the average railway work

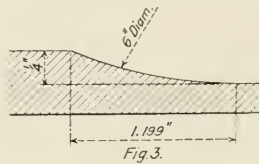

Fig. 3.

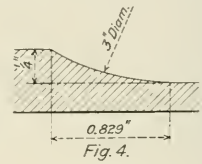

Fig. 4.

as they have little drag on the milled surface, that is, they will remove a short chip. Too small a cutter, however, limits the size of the arbor and a happy medium must be struck. Figs. 3 and 4 show graphically a cut $\frac{1}{4}$ in. deep taken by two cutters 6 in. and 3 in. in diameter. The 3-in. cutter will be in contact .829 in. and the 6-in. cutter 1.199 in., or approximately 14 per cent longer. As a result, the larger cutter takes a longer chip than the smaller one, which is objectionable on account of extra wear on the cutting edges. The inserted tooth cutter cannot well be made small and have the necessary strength of body to properly support the blades, and while they are cheaper at the present abnormal

price of high speed steel, they cannot be recommended where the smaller solid cutter can be used; this applying particularly to plain flat surface milling.

The nature of the work must naturally govern the cutter diameter and no hard and fast rule can be laid down to govern all cases. As a general proposition, however, for the facing of articles as mentioned above, cutters $4\frac{1}{2}$ in. in diameter, with a 2-in. arbor hole answer the requirements very well. With a 2-in. arbor, the use of the arbor supports, supplied as part of the machine, will prevent objectionable chatter under heavy cuts, but this size of cutter will admit of only about two redressings which makes an expensive cutter at the present price of high speed steel. However, it will be found cheaper than carbon cutters per 100 pieces milled, to say nothing of the saving on account of higher speeds. Solid cutters of $4\frac{1}{2}$ in. diameter, 3 in. to 6 in. long, with a 2-in. hole are very useful tools on these machines. Where cutters must be larger than $4\frac{1}{2}$ in. the inserted tooth is generally used. For heavy and fast



Fig. 5.

milling the blades should not be less than $\frac{1}{2}$ in. thick and they should have all the spiral the design will permit. Many an inserted tooth cutter has failed on account of too thin blades that would not stand the strain and carry away the heat from the cutting edge. The objections to inserted tooth cutters are the difficulty of obtaining sufficient spiral, lack of chip space and liability of breaking the teeth.

Face Mills.—For railway work face mills are useful and work equally well if made solid or with inserted teeth, the latter being generally used except in the smaller diameters on account of lower cost. In face milling, practically all the cutting is done by the periphery of the cutter, as is the case with a slab mill. Therefore, the teeth should have the same degree of rake and angle as the slab mill. For rapid cutting, the blades must be thick and heavy to stand the strain of heavy cutting. At least $\frac{1}{2}$ -in. blades are desirable and several good makes of cutters suitable for railway work are now on the market. Face mills are useful for milling driving box cellars and a number of castings used on the locomotive and tender, as well as steel passenger car parts requiring finish.

Formed Cutters.—For certain work, such as the rounded edges of rod keys, concave cutters can be used to good advantage and these may be purchased with practically any radius demanded, and can be ground without change of contour. The time required to mill a rounded corner or a half round is very much less than planing with a concave planer tool and also the surface will be much more accurate. A good illustration of the possibilities of form milling can be found in the transmission gear shafts of automobiles, where the shafts are milled to fit the broached holes in sliding gears. This calls for a class of milling nearly perfect and is probably a better grade of work than demanded for locomotive or car construction, or repairs.

GRADE OF FINISH

Locomotive and car parts coming within the range of the machines in question rarely require a "dead" smooth finish and generally where the machines and cutters are kept in good condition, the work as it leaves the machine is smooth enough to meet all the requirements without additional work except the removal of burrs.

Where milling at a rapid rate of feed, say six inches per minute or more, the surface will show decided revolution marks resembling humps and hollows that may appear a

great objection at first glance. Figuring shows that with a 4-in. cutter and feed of $\frac{1}{8}$ in. per revolution, the hollows will be .00097 in. deep; and with 1,16-in. feed, the hollows will be .00024 in. deep, or an amount so small that it cannot readily be measured on a flat surface. It would be difficult to find a place on a locomotive or car where a surface as smooth as this would not meet the requirements, as far as wear or fitting are concerned. Should a very smooth finish be demanded, such as the surfaces of rod keys bearing on wedges, either of two methods can be followed. One is to speed up the cutter to possibly 60 ft. cutting speed and feed at a rate that will produce a satisfactory finish, say at three inches per minute. The other method is to take a rough and a finishing cut; the rough cut at 40-ft. to 60-ft. cutting speed and feeds of 6 in. to 10 in. per minute, and afterwards a finishing cut at the same setting by raising the machine table from .005 to .010 inch, the finishing cut being made at the same cutting speeds, but slower feeds. The first method is quicker and generally satisfactory where the article to be milled can be clamped to prevent springing. For a frail article that is liable to spring under a heavy cut, the second method will produce more accurate results.

Face milling with well ground cutters will present a smoother surface than slab milling. However, a face mill requires more time to take a cut as the cutter must feed the length of the piece plus the diameter of the cutter. Unless cutters are very carefully ground, one or two teeth are liable to project more than others and produce a rough finish; also, the milling machine must be in a good state of repair and the spindle at exact right angles to the ways to prevent cutting hollow.

MILLING LOCOMOTIVE PARTS

A brief description of methods of milling a few locomotive parts may be of interest.

Piston Valve Bushings—Ports.—These ports can be very quickly machined on the plain knee type milling machine, and for this work the so-called end mill is used. It should preferably be spiral with but few teeth and of a diameter as large as the design of the port opening will admit. For holding the bushing, a rotary table that can be obtained with the milling machine can be used to good advantage and it is desirable to provide a disk of boiler steel about $\frac{1}{2}$ in. thick and accurately center it on the table. This disk should fit the bore at the end of the bushing which will center the bushing on the table, the bushing to be held down by clamp bolts inside. The revolving table should be rigid as with some designs of valve bushings the port holes will be some distance from the table, which will put considerable strain on the same when taking heavy cuts at a rapid rate. The port holes should be marked on the bushings and the machine operator can then revolve the table and raise or lower it to follow the lines marked on the bushing. With proper appliances, the admission ports in bushings, cast from moderately soft cast iron, can be milled in one hour and insure accuracy to a few thousandths of an inch in width. High speed steel mills should be used for this purpose.

Link Motion Levers.—These are milled in a very satisfactory manner and in much less time than is possible by slotting or planing. There are so many designs that no hard and fast rule can be given to meet all conditions; also, for plain milling machines the length is limited to cuts of about 45 in. One method of milling is to first mill the flat sides at the ends of the levers, this being done when holding the levers in a vise supplied with machine. For the longer levers two vises are employed and plain slab milling cutters are used for the purpose. With a good grade of forgings the milling can be taken at cutting speeds of 40 to 80 ft. per minute and feeds of 3 in. to 6 in. per

minute and produce a finish generally meeting all requirements; this being a job where the ability to hold the piece on the machine, rather than the cutter capacity, governs the speed of milling. The flat milled surface is very desirable for drilling the holes for motion pins and also where the design admits, a large hole can be drilled at the bottom of the jaw and the metal up to the hole cut away with a cold saw. It is best to operate two saw blades at one time, properly spaced to cut out the entire block at one travel of the saw. Where cold saws are not available, these blocks may be removed by sawing on the milling machine. This requires a large saw, probably 10 in. to 12 in. diameter, and a saw of this diameter cannot well be driven by the usual method of collars and key or spline, on account of shearing the latter. One method followed to overcome this difficulty is to order saws having four holes drilled in them, about 2 in. radius and make a pair of collars properly drilled to register with holes in the saw, and bolt through the saw and collars, a keyway being cut in the collars and saw. This will allow ample driving power.

For the remaining milling it is desirable to make a holding or milling fixture and a simple design for this purpose can be made from steel about $1\frac{1}{2}$ in. thick and about 6 in. longer than the piece to be milled and 1 in. or 2 in. wider than the lever. This bar is milled to fit grooves in the milling machine table and pins should be located in the fixture, spaced exactly the same as the holes in the lever to be milled. When milling, the lever is to be clamped onto this fixture by the usual method followed on planer work.

A fixture of this nature has advantages over holding in a vise, as the piece can be held more securely and avoids possibility of shifting when milling. Also, as the lever will be located in exact reference to the table, the throw-off stops for the milling machine table can be properly set to mill each piece alike. This is an advantage when milling to a fillet. By a careful setting of the machine, any number of parts can be milled without the necessity of laying off, as is generally the practice where the articles are machined on planers or slotters.

For milling the inside of jaws it is customary to employ a cutter about $\frac{1}{4}$ in. smaller in diameter than the opening and this cutter should preferably have an outer support in the arm support supplied with the machine. This can be arranged for by making the outer end of the cutter of a diameter about equal to the bottom of the teeth, or to the nearest standard size of arm brace bushing. Fig. 5 illustrates the cutter.

It is generally desirable to mill on the bottom jaw and turn over for milling the opposite side. By this method the cutter can be fed to the large hole drilled at the bottom of the jaw. Conditions arise where this cannot be done on account of the holes in each side of the jaw not being alike and where the jaw must be milled from one setting. In this event, after milling the lower surface, the table can be lowered for milling the upper jaw. To mill the upper jaw it will be necessary to clamp the upper jaw to prevent it from springing. Surfaces other than the round ends are very readily milled on the fixture mentioned. The rounded ends of these levers cannot well be milled on the plain horizontal milling machine without the use of a vertical milling attachment and circular table and if large vertical milling machines are available, they should be used. The levers can readily be held by a center bolt secured to the revolving table.

When milling these levers it is very essential that the operator make use of the micrometer dials on the table, especially when facing the surfaces between the ends where it is necessary to raise the table to a predetermined distance, in order to obtain the correct thickness of the lever. Where this is insisted on, the operators soon become accustomed to

making several different cuts on one piece without measuring with a rule or calipers.

It would be difficult to give an exact comparison of time for milling as compared with slotting or planing, as much depends on the design of the lever and the operators. The time for setting up should be about the same for either operation. Milling should eliminate laying out the lever, where advantage is taken of the table stops and micrometer dials. The finish by milling will be generally smoother than slotting, and unless a high polish is demanded, the pieces can be milled smooth enough for use without other finish than removing burrs. The time of actual milling should not average over 50 per cent of the slotting time, so that the milling should result in considerable economy.

Driving Box Shoes and Wedges.—If a dead smooth finish is not considered essential the milling cuts on driving box shoes and wedges can be taken at the fastest speed the cutter will stand. With fairly good forgings and removing not over $\frac{1}{4}$ inch depth of cut, a cutter speed of 60 ft. per minute and feeds of 3 in. to 6 in. per minute can be obtained, the rate of feed being largely governed by ability to hold the wedge on the holding fixture. It should be borne in mind that the thrust from the milling cutters on the wedge is quite heavy as from 15 to 20 hp. will be consumed when milling to the limit of modern cutters on a surface of this kind. All the thrust of the cutter must be taken up by the wedge, and unless the piece is well secured, it is liable to shift or slip and damage the cutter.

On account of the taper generally given these wedges, it is advisable to make a holding fixture for the milling. This can be made cheaply from cast iron or a forging of the same width and 2 in. or 3 in. longer than the wedge, the extra length being necessary for bolt holes for clamping. This block should be about 2 in. thick at one end and tapered like the wedge and it is advisable to place a tongue or spline in the bottom surface to fit grooves in the machine table. A substantial stop should be bolted to the thicker end of this block to take up the thrust when milling. For holding the wedge on the block, the customary planer practice of pointed screws pointing slightly downward, or pointed pins pressed onto the wedge from cup pointed screws answers very well. The customary form of blocks used for the screws can be held from grooves in the table, as in planer practice. The thick end of the wedge should point towards the cutter.

When setting up a long piece of this nature it is often necessary to drive thin wedges under the high places which will prevent the piece from springing. This applies especially on the first side milled and the second side can be milled without wedges. One cut over each of the flat surfaces will produce a smooth surface that should meet all requirements. The sides of the wedges can be milled two or four at a time when held in the milling machine vises, the wedges being turned end for end for parallel holding. The rounded corners can be milled with concave cutters and it is advisable to use two and space them so as to mill both sides at one time. For this operation the wedge is held on the holding down block. The ends of the wedges can be readily machined by face mills while holding the wedge in the machine vise. The actual time of milling would be approximately as follows for wedges 18 in. long:

2 Flat surfaces, 4-in. feed per min.....	9.00 min.
2 Edged (two milled at a time), 6-in. feed per min.....	3.00 min.
Rounding corners, 8-in. feed per min.....	2.25 min.
Ends (assuming 8-in. wide wedge), 4-in. feed per min.....	4.00 min.
Total	18.25 min.

To this must be added the time required for cutters to enter and leave work. However, 20 min. can be considered a fair approximation of the total time required and the speed of milling quoted above can be lived up to in every day practice. Some milling machine makers will advocate

greater speeds, but too great a speed can only be obtained by sacrificing the life between grinding of cutters. The time required to set up work was not considered in the above result because it should be about the same for millers or planers but any fair trial will prove the superiority of the former.

Driving Box Cellars.—Where the design calls for finished surfaces next to the driving box they can be milled to good advantage on the knee type of machine and a very satisfactory method is to clamp to the table as many cellars as the travel of table will admit, the surface to be milled being set to extend over the side of the table about $\frac{1}{2}$ in. This method of setting admits of using face mills which are preferable to slab mills on frail surfaces like these cellars. The diameter of the face mill will be governed largely by the width of the surface to be machined, too large a mill being difficult to grind and insure each tooth cutting an equal amount. Ten in. mills for this and general work appear to be a good compromise. Should the surface to be milled exceed the limit of the 10-in. cutter it is advisable after taking one cut to raise or lower the table for a second cut rather than use too large a cutter. Cast iron cellars should be milled dry, or possibly the surface washed with kerosene oil to prevent dust, but steel cellars should be milled using a cutting compound.

Steel Castings.—On account of the surfaces of steel castings being full of sand and grit, they do not at first glance look promising for milling, but as a matter of fact, they can very readily be milled with only average grinding of the cutters. Where possible the use of the face mill is preferable on account of cutting under the scale. It is very important that the cutters be flooded with cooling compound, both to keep them cool and to wash away the sand that is loosened by the mill. The speed of milling steel castings can be about the same as for carbon steel forgings.

Rod Brasses.—With proper care rod brasses can be milled to fit the jaws of main rods without other fitting or filing than that of removing burrs. While very careful attention to measurements and fixtures is necessary, the work can be performed by workmen not having any great amount of experience in shop work or on milling machines. The varying sizes of rod jaws makes it necessary to fit practically each set of brass to a particular rod, which in turn necessitates measuring each rod separately and fitting each brass individually. A very satisfactory method of handling this work is to make a revolving holder for the brasses with four point index plate divided very accurately for insuring the sides of the brasses being square, the distance between the flanges being taken care of by raising or lowering the table. End shell mills of about 3 in. diameter are well adapted for this purpose.

A very satisfactory method for fitting these brasses without filing is to measure each rod, preferably with micrometer calipers, and also measure the various surfaces of the brasses as each surface is milled and adjusted, to obtain the required sizes. That is, if the first or trial cut shows say .015 in. over size, the table can be adjusted that amount as indicated by micrometer dials on the different table adjusting screws, and a second cut taken. This method is not difficult after a little practice and, of course, requires care on the part of the operator, but no great skill. Fitting rod brasses by any method requires care and where milled, the surface will be more accurate than the average filing, and in shops where a number of rods are fitted, the milling process will be found the more accurate and economical.

COOLING COMPOUND

The value of having an ample supply of cooling compound flowing over the tool to properly carry away the heat generated by the cutter is hard to estimate, and without it the present high speed of milling would not be possible. Looking

backwards at old practices with milling and other machines makes one wonder why we didn't flood the cutters at an earlier date. For years it had been the practice to flood the chasers of bolt cutters and taps in nut tapping machines and we all knew the value of the same. Probably the fact that the old style milling machine was equipped with a can from which some 10 to 40 drops of oil per minute could be fed to the cutter prevented experiments of flooding cutters.

With the advent of high speed steel cutters and the increase of speeds it was found that the limit of speeds was reached when the chips removed showed the effect of heat by discoloration, this being an indication of dull cutting edges. Flooding the cutters with cooling compound has the effect of cooling each cutting edge of the cutter after taking a chip so that when coming into play again the edge is cool, and the work is also kept cool. An article milled at high speed and also the chips show no indication of heat when handled directly after milling with a flooded cutter, but if the cooling compound is shut off the chips will discolor at once.

Many old milling machines of the planer type used largely on rod work, also the upright type and the tool room millers as well as the plain knee type, have been speeded up above their original rate of milling as a result of the application of a more liberal supply of cooling compound. This has generally required larger pumps and piping and where used has at times resulted in overflowing the tables, making it necessary to increase the passages from table to tank and to place extra guards around the table to prevent flooding the floor. However, where the machines have been equipped for greater supply of cooling compound, the results have well justified the cost on account of a greater output from the machines. It is cheaper to speed up machines than to buy new ones.

It is not advisable to direct the compound on the cutter with great force on account of sparking, but it is desirable to have a large stream at low pressure and for the average machine, pumps to supply 10 to 15 gallons per minute, answer very well.

Several forms of nozzles are used and for plain slab milling, some prefer a sheet metal or cast hood, covering about half the top of the cutter, the cutting compound being fed to the top of the hood. This floods the cutter in a very satisfactory manner and is also to a certain extent a safety measure. For some work a flattened nozzle about the same width as the cutter is long is used, delivering compound as near as possible to the point of cutting.

For face mills a pipe directed onto the face of mill near the entering side of the cutter answers very well. Where milling jaws like the ends of link motion rods, the compound can be directed into the jaws and onto the cutter by two pipes bent like the letter C. For vertical mills such as used on side rod ends a plain pipe pointing towards the point of contact of cutter and work is used. Experience will soon dictate satisfactory forms of nozzles for various kinds of milling.

Most any good cutting compound answers fully as well as oil, the object of the compound being to conduct the heat away from the cutters. Oil cannot be recommended on account of excessive cost. Cooling compound is of no value for ordinary brass castings or cast iron.

The output of most old style milling machines can be about doubled by following the plan of keeping the cutters cool as outlined above and this applies to the smaller tool room machines as well as to the larger millers. Where machines are not so equipped it would undoubtedly pay to apply a cooling compound system.

GRINDING CUTTERS.

The use of properly ground cutters is especially essential in order to obtain the maximum output of milling

machines, and unless this is attended to, high rates of speeds and feeds cannot be expected. Considering for the present the outside of the tooth, it is very necessary that it be ground to give the correct amount of back clearance. Too sharp an angle will cause the cutter to chatter, hook in and produce rough surfaces. Too little clearance will cause the cutter to drag and prevent proper cutting. Many a cutter has been condemned on account of too sharp teeth or angle where a slight removal of the keen edge either by grinding or wear would have remedied the trouble. No hard and fast rule can be given governing the amount of clearance, as different metals will require different degrees. For steel such as used largely in locomotive construction, a back clearance of about three degrees appears to be satisfactory for a 4½-in. cutter. It is a good plan to occasionally measure this back clearance which can readily be done by a bevel protractor. The data obtained will be available for grinding future cutters. Sheet steel gages made to the proper angle for testing cutters after being ground will be a great help. When a happy medium has been arrived at for grinding the back angle, it will be found that cutters as they come from the grinding machine will go off at once without nursing as is often the case with improperly ground cutters. Some of the cutter grinding machines are arranged so that the amount of back clearance can be adjusted and machines having this attachment should be carefully studied and set to give a properly ground cutter.

To grind the front rake of a tooth or the undercut surface is somewhat difficult on the average universal grinding machine, but it can be performed in a fairly satisfactory manner by setting the grinding spindle at right angles to the groove in the cutter and using a cup grinding wheel. The cutter must be passed back and forth holding its face against the wheel. Some of the later grinding machines are equipped with spiral grinding attachment that will grind this surface nearly perfect. Even with the hand method, however, the results obtained in the way of longer life between grindings, fully justifies the additional expense of this one grinding. As pointed out before, this grinding of the face of a tooth may be likened to the grinding of the top face of a lathe tool, and who would think of making use of a lathe tool that had not been ground on the face after hardening. A smooth surface is absolutely necessary to prevent the chip dragging on the lathe tool or the cutter tooth face. The question as to how often a cutter should be ground may be answered by observing the chips. When these show a discoloration in spite of a liberal supply of compound it usually indicates that the cutter teeth are either dull or broken.

MANUFACTURE OF CUTTERS

The cutters principally referred to above are the coarse tooth, the undercut spiral, the face mill and the end mill, and these are now regularly supplied by several tool manufacturers. These concerns make cutters by the hundreds with up-to-date appliances for milling, drilling, grinding, hardening, etc., and can, without a doubt, produce cutters cheaper than railway shops. The manufacturers generally replace any cutter developing flaws either in hardening or in use and in view of the fact that railway toolrooms are generally crowded with work, the question of the purchase of all standard cutters should be favorably considered.

Railway shops, like a number of manufacturing concerns, generally have a large number of old fine tooth carbon steel cutters on hand and it looks like a crime to scrap them. However, in light of what is being done every day in way of high speed milling, and where the labor cost is very much less than with the older cutters, there can be no question of the economy in providing new equipment of up-to-date high speed cutters for milling the parts entering into locomotive and car construction. We eliminated the carbon steel lathe

tools and should do the same with carbon milling machine tools.

POWER REQUIRED

For the same conditions and machine the power required will depend largely on the design of the cutter, and its sharpness and good cutters having undercut teeth and milling $\frac{1}{8}$ in. to 3 16 in. deep will require 3½ hp. for each cubic inch of soft steel removed per minute. A large No. 5 knee type milling machine on heavy work will consume from 15 to 20 hp. However, it should be borne in mind that the actual cutting is only going on a small per cent of the time with the modern milling machine as the cuts are taken very quickly and the actual horsepower hours consumed per day will not be excessive. As a rule it will be found that the time of setting the pieces in the machine will generally equal the time of actual milling.

ARBOR AND ARM SUPPORTS

It would be quite difficult to give any definite rule governing the size of the arbor to be used, but most railway shops call for heavy cutting, and to accomplish this large arbors are necessary. On the other hand, large arbors require large cutters which are more expensive than smaller ones. The chattering of a cutter which is very objectionable, on account of rough work and dulling the cutter edges is often the result of using too small an arbor or improper arm support. For general work the 2-in. arbor, use must be recommended. However, with this large arbor, use must be made of as many arm braces as possible. A good rule is to use all the braces that are possible, as there is no danger of using too many.

In this article which has only mentioned a very small per cent of the jobs that can be done on milling machines, cutting speeds and feeds have been given that may appear high when compared to practices of a few years ago. They are really conservative, however, and can readily be duplicated in every day practice. A number of concerns are now milling at speeds very much faster than what has been mentioned. Of course, in order to obtain high speeds it is necessary to keep cutters and machines in good condition. The question of holding the work is about as difficult as any that will be encountered, as high speed milling exerts a very heavy thrust on the article to be milled.

Attention has been called to the large No. 5 milling machine. It may be argued that smaller and cheaper machines are strong enough for railway work and this is true for a large number of parts, but experience with wheel lathes, center lathes, turret lathes and boring mills as well as milling machines has demonstrated that a strong and heavy machine tool will turn out more work per day and with less grinding of tools than a lighter machine.

TRAVELING IN MODERN RUSSIA.—A most entertaining picture of present-day railway travel in Russia was recently contributed to the Daily Mail (London), by Alexander M. Thompson, a well-known writer on labor matters. Mr. Thompson desired to travel from Petrograd to Moscow, and was "enviously congratulated" by his Russian friends when he succeeded, through a friendly commissionaire, in booking a sleeping berth at less than four times the official price. Mr. Thompson's train, the last of the day, was due to start at 10 o'clock on a Tuesday. When he arrived at the station, in very good time, he was informed that the train had started three hours earlier. "When I told my Russian friends who had congratulated me on my extraordinary good fortune in securing the ticket," continued Mr. Thompson, "they merely shrugged their shoulders comfortably and murmured the magic word, Nitchevo (never mind), and assured me 'That's Russia.' Meanwhile I wonder when I shall reach Moscow, Nitchevo."

THE UNIVERSITIES AND EQUIPMENT DEVELOPMENT

Many Problems Can Only
Be Solved by the Designer
on the Basis of Facts Obtained
by Scientific Investigation

The University of Illinois Test Plant in Action



THERE are many problems arising in the design of cars and locomotives, in his efforts to solve which the designer is forced to depend largely upon more or less unsupported opinions. Many of these questions would be susceptible of a precise settlement were the necessary data at hand. More particularly in the case of locomotives, this applies both to the proper proportioning of various parts of the design for the most economical performance and to the design of many of the details from the standpoint of strength and ease of maintenance. Our methods of improving design, based largely upon a superficial observation of performance in service, have too often led to a local treatment of the symptoms, rather than the location of the cause of the disease which is essential before the proper remedy can be applied.

The solution of many of these problems requires a thorough, scientific investigation with the accumulation of much data, the prosecution of which few railroads have either the facilities, the organization, or the money to undertake independently.

There are several universities equipped with laboratory and test plant facilities which are ideal for use in the study of many of these problems. Of course it must not be forgotten that the primary purpose of these facilities is the preparatory training of men in the engineering profession. But they are kept busy only a small part of the time in purely educational work. Why can they not be devoted to the study of practical problems to the great advantage not only of the transportation industry, but of the men who are receiving their training in these institutions?

THE FIELD FOR TEST PLANT STUDIES

Inquiry as to the practicability and desirability of such a course was made among a number of engineers who are interested directly in the design of equipment. The way in which they responded to this inquiry indicates a very deep interest in the subject. This was especially true on the part of locomotive designers.

Suggestions as to subjects suitable for this kind of investigation were made by a number of the best known engineers in the field of railway equipment design. While the test plant is of value only in dealing with locomotive problems, there still are possibilities for the employment of impartial investigations for the development of data much needed by the car designer.

As will be evident from a study of the following paragraphs, the extent of the field outlined by these suggestions presents great possibilities for practical usefulness for the available university locomotive testing plants, as well as other laboratory facilities.

In order to define clearly the scope of the field in which such investigations are practicable it must be borne in mind that there are two kinds of development in equipment design—improvements by invention and improvements resulting from the gradual evolution

IN many respects our methods of locomotive design have hardly advanced beyond the "rule-of-thumb" stage.

There is need for accurate data on which to base a logical proportioning of boilers.

Our knowledge of the comparative value of a great variety of locomotive fuels, and of the conditions under which they may best be burned, is extremely limited.

The available knowledge on the subject of locomotive drafting is very crude.

There are parts of the running gear for which the present methods of designing for strength are not wholly satisfactory.

There is a real need for a well-planned and painstaking study of these subjects.

Why not utilize the test plant and laboratory facilities of universities equipped for teaching railway mechanical engineering, in the investigation of these subjects?

The universities and the railroads, both, would benefit from such a course.

of existing things. Inventions frequently require years of preliminary work and trial before reaching a practical stage of development. Such improvements may be quite revolutionary in their application as compared with existing designs. The highest development of existing types of design requires patient investigation and testing in order to establish their limitations, and rules and formulas for their use.

Obviously the first class does not lend itself to co-ordinated efforts and it is in the second class that the co-operation of the universities should be enlisted, since organization and laboratory facilities lend themselves more readily to such tests and investigations. The investigations to which our educational institutions lend themselves, must, of course, be of a strictly impartial nature and the results made available to all designers.

BOILER AND FIRE BOX DESIGN

The need for a more scientific knowledge of the conditions affecting the many phases of the problem of proportioning locomotive boilers and fireboxes is very generally felt. Here is a list of pertinent subjects for investigation:

1. The effect of grate area upon firebox evaporation.
2. The effect of firebox volume upon firebox evaporation.
3. The combined effect of grate area and volume upon firebox evaporation.

The firebox receives practically all of its heat by radiation from the fuel bed and flames, and the amount of heat radiated depends upon the temperature and area of these heating surfaces; but there is no method of approximating them. Does the heat from the fuel bed pass through the flames above, or is it absorbed by the flames and radiated by them to the firebox heating surfaces? In other words, knowing the temperature of the flames and the incandescent fuel on the grates, can the firebox evaporation be calculated by adding the area of fuel bed radiating surfaces to the area of the flames; or must flame area alone be considered?

The information needed to answer these questions could be secured by running a series of tests with fuel of different characteristics. For instance, coke (which burns without any flame) could be used in a series of tests to determine the firebox evaporation, followed by another similar series of tests using medium or low volatile coal, and a third series of tests using high volatile coal.

Such a program would, no doubt, present many difficulties; but a university equipped with a modern testing plant, and with sufficient funds provided for this work could overcome the difficulties, and information could be made available which would be of vital importance for a correct understanding of the fundamentals of firebox design.

4. The length and volume of combustion chambers required for the complete combustion of various kinds of coal.

At present there is no definite knowledge as to the value of combustion chamber space. How far should we go in installing combustion chambers? What should the length be for a specific grade of high volatile, low volatile, or anthracite coal?

5. The relation of tube length to diameter necessary for the highest combined capacity and efficiency.

This should be worked out in conjunction with combustion chambers, as the lengthening of combustion chambers necessarily shortens the tubes. Some work on this subject has been done by the Pennsylvania Railroad at its Altoona testing plant, and by the Babcock & Wilcox Company. The work which has been done, however, has not covered a sufficiently wide range of conditions and the conclusions reached are not definite enough to be wholly satisfactory.

Many roads have been experiencing trouble with locomotives of the 2-10-2 type because of their poor steaming qualities. This is due primarily to their long tubes and the inadequacy of the front end arrangement. Boiler capacity and efficiency cannot be secured by merely increasing the boiler heating surface. Indeed, there are probably many locomotives in service the boilers of which have more heating surface than they need.

No attempt has recently been made to use a tube in the locomotive boiler smaller than two inches in diameter. To do so has seemed impracticable because of the impossibility of keeping small tubes open.

But are the troubles arising from the accumulation of solid

matter and the plugging of tubes, due primarily to the size of the tubes? Is not the real cause to be found in the conditions leading to imperfect combustion in the firebox? With a firebox having sufficient grate area, combustion chamber space and flamework, a means for thoroughly mixing the gases and an air supply sufficient to approximate perfect combustion, could not the plugging of tubes be eliminated, or so greatly reduced as to make the use of tubes smaller than two inches in diameter entirely practicable? It is known that the efficiency of the tubes increases as the diameter decreases, and the successful use of long combustion chambers with short tubes depends upon the possibility of using tubes smaller than the present diameters.

6. Boiler tube performance.

As a part of other investigations already outlined or as a separate study, it might be of value to determine the evaporation of boiler tubes for different portions of their length, giving more information as to the curve of temperature drop between the firebox and the smokebox than is now available. In this connection, a study of the smokebox vacuum necessary to pull the gases through tubes of varying length and inside diameter would be of value.

It might be possible to arrive at satisfactory conclusions in such a study by experimenting with single units. For instance, a boiler tube 2 in., $2\frac{1}{4}$ in. or $2\frac{1}{2}$ in. in diameter could be enclosed in one of sufficiently larger diameter to contain about the same amount of water as is actually heated by a single tube in a locomotive boiler. These units could be made up in different lengths and the necessary temperature and draft readings determined with a considerable degree of accuracy. The hot gases should be supplied from a furnace or some other source giving a uniform flow and controllable temperature.

FUELS AND COMBUSTION

The whole subject of the relative value of a wide range of fuels is awaiting the kind of attention which can be given to it only where test plant facilities are available. Invaluable data might be secured from a series of comparative tests of oil fired and coal fired boilers, and pulverized fuel combustion offers a virgin field for investigation.

Tests to determine the most efficient rate of combustion, with due consideration of the proper balance of fuel efficiency, over-all efficiency and locomotive capacity would undoubtedly lead to better firebox design.

DRAFTING

So far as is known, there have never been any reliable tests made to determine the effects of air openings through the grate upon firebox temperatures and the completeness of combustion. Firebox temperatures, proper length of flamework, and combustion chamber space depend upon the air supply. There are many railroads in this country using grates entirely unsuited to the character of the coal that is being burned. Probably most of them could use grates with more air openings to considerable advantage. In a general survey of locomotive drafting there is much to be learned from a careful study of ash pan and grate design.

The so-called "Master Mechanic's front end" has never been adopted by all the railroads in this country, possibly for the reason that it has not given satisfaction under all conditions. There can be no doubt but that there is ample room for improvement in front end arrangement, particularly as to the exhaust pipe and nozzle.

If the efficiency of the exhaust depends upon the entraining action of the steam, there is no logical reason why the present form cannot be improved upon by increasing the entraining surface of the jet. Recent tests show that irregular shaped nozzles, such as those of the rectangular, dumb-bell or internal projection form possess some advantages over the ordinary circular type. The theory of the entraining

action of the jet accounts for this, but how far this theory holds true in practice has not yet been definitely fixed.

There is still room for further investigation to determine the most efficient diameter and shape of smoke stack.

Considerable development work on the application of mechanical draft to locomotives has been done by H. B. MacFarland, engineer of tests of the Atchison, Topeka & Santa Fe. The results obtained, however, have not been conclusive as to the extent to which increased efficiency in the production of the draft may be obtained by the substitution of an adequate mechanical draft system for the present exhaust jet.

SUPERHEATING

Investigation might possibly be made of the over-all efficiency obtained with the superheater, considering the drop in pressure through the superheater units. In this connection a study might be made of the design to minimize the pressure drop through the superheater.

FEEDWATER HEATING

In an investigation of this subject, a determination of the per cent of the weight of steam used which can be diverted without detriment to the draft, would be of interest.

STEAM DISTRIBUTION AND ECONOMY

From the throttle valve to the exhaust pipe there are many features of the steam conveying and distribution system, the design of which is based very largely upon tradition. In many cases material improvement might be effected if accurate data as to the effect of varying proportions, sizes, etc., based upon a thorough investigation, were available for the designer. Some of the questions involved are:

What is the effect of varying sizes and proportions of throttle, dry pipe and steam pipe upon the pressure drop between the boiler and steam chest?

What is the best diameter of piston valves and the proper shape of steam ports from the standpoint of efficient steam distribution?

What is the most efficient clearance for locomotive cylinders and what valve setting should be used to provide the greatest steam economy for the starting, accelerating and speed requirements of different classes of service?

An investigation of uniflow cylinders.

The determination of leakage past piston and piston valve packing rings.

MECHANICAL INVESTIGATIONS

In the past few years the use of main rods with solid back ends forged integral with the rod has greatly increased. There have been numerous failures around the opening of this type of rod. The only remedy so far applied has been to add more and more metal to the section, making it larger and heavier, but with no accurate data upon which to base calculations for strength. In other words, the design of this detail has been developed by "cut and try" methods.

There is comparatively little data on the strength of main rod sections, considered as columns. It has been suggested that there is a possibility of increasing the working stresses now used, particularly when certain high grade steels are utilized. The determination of a satisfactory answer to this question would involve tests of the column action of full size main rod sections.

For many years past locomotives have constantly been growing larger and the same principle of equalization has been maintained that was used upon the smaller and lighter locomotives built for rough track conditions no longer commonly existing in this country. There has recently been a tendency to depart from these established methods of equalization and to make a partial approach to what may be termed the European method of spring suspension. This is a problem about which we know very little and the importance

of which is gradually becoming realized by railroad men.

The investigations at the time of the Woodlawn wreck on the electrified division of the New York Central developed the fact that there was practically no experimental data as to flange pressures and tracking of rigid wheel bases such as are used on locomotives, when operating around curves. Since that time some theoretical studies of this question and a few actual tests have been made. The extent of the work so far done, however, has not led to results which are generally considered conclusive. This is one of the most important questions confronting the designer and one which is very well suited to more extensive experimental work. A study of the resistance of various types of engine truck centering devices would also be of value in a general study of the tracking of locomotives. These investigations would require road tests.

For many years locomotives have not only been constantly increasing in size and capacity through the development of new types, but axle loads have been very materially increased on all types. As a result axles have increased in diameter until now it is not unusual to find them with journals as large as 18 in. in diameter. An investigation of the limiting peripheral speed of bearings in relation to the unit bearing pressure would furnish the designer with some much needed data. Closely related to this subject is the question of the most efficient shape of crown bearings from the standpoint of lubrication and freedom from heat. The two would require co-ordinate investigation.

This is only one of the investigations which would be required in a thorough general survey of the internal resistance of the locomotive and tender, the results of which might be the basis for refinements in running gear design.

CAR DESIGN

Formulae for the design of the various members of cars, both passenger and freight, are based upon theoretical analysis of the stresses involved. Would not a series of tests laid out to prove the correctness of these formulae, and especially to establish correct design of connections, lead to much greater certainty in securing well balanced designs? The growing weight of equipment is getting to be a matter for serious consideration. In a design not perfectly balanced, where the strength of many details is in excess of the strength of the weakest points of the design, it is obvious that unnecessary weight is being included.

No doubt there may be differences of opinion among engineers as to the advisability of attempting to solve some of the problems mentioned by impartial technical investigations, as suggested. On the other hand, no doubt, other subjects suitable for study in the laboratory or on the testing plant will suggest themselves to each individual who is thoroughly conversant with the many difficult problems confronting the locomotive designer. In the list of subjects mentioned here alone, there are enough that are beyond controversy to indicate very clearly the possibilities for the more intensive utilization of the facilities of the universities equipped for teaching railway mechanical engineering.

It is hardly necessary to call attention to the fact that in the conduct of such investigations some concessions might often be necessary from the purely academic point of view, in order that the results obtained might square with economic conditions and the many limitations within which the designer must work. In meeting these conditions, however, it would probably not be necessary entirely to divorce these practical studies from the purely educational utilization of the laboratory and test plant facilities. Would not the practical study of such problems in the university laboratory and testing plant afford the engineering student an opportunity to acquire a conception of the practical limitations under which he must apply his theoretical training, which so many college graduates lack today?

INCREASE ENGINE TERMINAL OUTPUT



ONE OF THE GREAT strategic points in the railway battle front is the engine house. It is the work of the men at this point that has contributed largely to the success with which the railways have been able to meet the greatest demands for transportation in history. It is a point that must be reinforced both by men and by facilities. On some roads it is the neck of the bottle on which concentrated effort must be placed. The suggestions given in the following communications will help to solve some of the problems:

IMPROVE THE ENGINE TERMINAL FACILITIES

BY F. P. ROESCH

Master Mechanic, El Paso & Southwestern

When power is in demand, requiring a quick turn, the critical point is outside, and not inside, of the roundhouse. No doubt many will take exception to this statement, but I believe afterthought will prove to them that this is correct.

The number of men, mechanical facilities, tools, etc., inside of the roundhouse are usually adjusted to meet the demand. Conditions are so variable at different terminals that no hard and fast rule, in so far as organization is concerned, can be laid down. However, regardless of the character and efficiency of this organization, it is axiomatic that until there is something to work on the organization may as well be non-existent. In other words, the inside facilities are valueless until the engines requiring them get into the roundhouses. Therefore, the critical point is outside.

Visit the average terminal and see how they are fixed for track room, tracks to and from the turntable, cinder and inspection pits, coal, water, supply and sand facilities, and the point at once becomes clear. When we realize that results

cannot be obtained with poorly arranged, inadequate or congested terminals, and these matters are corrected, a long step will be taken toward the conservation or full utilization of motive power.

The matter of roundhouse organization has repeatedly been well covered by other writers and as in this matter local conditions must govern no reference will be made herein covering this feature, except a passing reference to outside inspectors, as these can be utilized to good advantage in all cases, regardless of inside organization.

An analysis of the terminal movement would, therefore, indicate the following:

Inspection Pit.—The first requisite, regardless of whether the power is pooled or assigned, is a proper inspection pit with competent inspectors and helpers. In organizing this force, use men as helpers who can make repairs that do not require a machinist, such as setting up wedges, keying

rods, tightening loose nuts, applying split and cotter keys, etc., the helper to follow the inspector and look after these details as directed. Such matters can be handled on the inspection pit in this manner in less time than it would take the inspector to write out or report the defects. The object in doing this work on the inspection pit is to have wedges set up while boxes and journals are warm and ex-

THE RAILWAYS of this country need locomotives. The demands of our Allies make it impossible for us to buy what is needed to replace those that are obsolete and which are no longer fit to run. We must get more service from our existing power. One way is to handle the locomotives more rapidly at the engine terminals. This requires a good roundhouse organization and adequate terminal facilities.

F. P. Roesch of the El Paso & Southwestern tells how these facilities may be improved on any railroad at the present time. F. J. Harrison mentions improvements in enginehouse organization on the B. R. & P.

All of the articles in this series contain concrete suggestions which will lead to decreasing the time a locomotive spends in the terminal. Above all things, the locomotive must be sent out of the terminal fit to do its full work. Adequate supervision and inspection are absolutely necessary.

panded and to have injectors, air-pumps, etc., tested under full steam pressure.

Cinder Pit.—The next move is to the cinder pit. The capacity and length required depend on the cinder handling facilities. But in every case too much pit for average business is far better than too little or just enough, as the cinder and engine capacity of this pit governs the time required for knocking fires and cleaning ash pans.

Turntables.—The next move is on to the turntable. This is a weak point in the average terminal—often too short, requiring slow movement, extreme care and nice adjustment for spotting of the locomotive to balance, and, also, too frequently, hand operated. Labor is too scarce today and time too valuable to put up with the short hand-operated turntable. Motors should be used, either air, gasoline or electric. If air, it should preferably be furnished from the shop compressor.

Roundhouse.—The next move is into the roundhouse and here, aside from the force employed, three distinct items enter largely into the time element, namely, boiler wash-

roundhouse doors, or to cause personal injury to the men as they may trip over it while climbing on or off the locomotive. A bucket full of sawdust or mill shavings saturated with one-half gallon of fuel oil spread evenly on a 4-in. bed of coal will cost less, will kindle a fire more evenly and quickly, will eliminate all possibility of nails, spikes, etc., getting into the grates and will leave the fire in much better condition than any scrap wood kindled fire. The scrap wood can be used to much better advantage elsewhere.

Roundhouse Blower.—In order to stimulate the fire, forced draft is necessary. This means a blower line of sufficient capacity to carry a pressure of not less than 50 lb. Too frequently do we see roundhouses with a small exposed blower line of a capacity so restricted that if three or more blowers are hooked to it at the same time no blower receives sufficient steam to create the required draft, with the result that either some or all of the engines are delayed.

Storage Tracks.—When the roundhouse forces are through with a locomotive, if roundhouse room is required, it should be moved out; and this again means storage tracks on which locomotives can be stored until they are called, so as not to interfere with in- or out-bound power. On the outbound movement sand, water, coal and engine supplies should be taken, the facilities for taking on these supplies to be so located as to cause no delay.

The above refers to the usual daily movement of all locomotives requiring boilers washed or water changed and

HOT WATER SYSTEM.

Class Eng.	To Empty Boiler	Time used			Get 100 lb. Steam	Coal (lb.)	Water
		Washing	Filling				
F 8 S40 min.	1 hr. 40 min.	18 min.	41 min.	1,212	
G 145 min.	1 hr. 10 min.	20 min.	45 min.	1,318	
F 3 S50 min.	1 hr. 25 min.	25 min.	47 min.	1,152	
F 6 S30 min.	1 hr. 10 min.	18½ min.	39½ min.	1,201	

COLD WATER WASHOUT SYSTEM.

Class Eng.	To Cool	To Empty	Total	Washing	Filling	Get 100 lb. Steam	Coal (lb.)	Water Est'd (Gal.)
G 12 hr. 5 min.	1 hr. 15 min.	3 hr. 20 min.	1 hr. 10 min.	55 min.	2 hr. 10 min.	2,110	3,500
F 8 S2 hr. 20 min.	1 hr. 20 min.	3 hr. 40 min.	1 hr. 30 min.	60 min.	2 hr.	1,896	3,500
F 6 S2 hr. 18 min.	1 hr.	3 hr. 18 min.	1 hr. 13 min.	55 min.	2 hr. 7 min.	2,014	3,500

SAVING IN FAVOR OF HOT WATER WASHOUT SYSTEM.

Class Eng.	Time	Water (Gal.)	Coal (lb.)
F 6 S4 hr. 55 min.	3,500	813 plus 30 equals 843
F 8 S4 hr. 51 min.	3,500	684 plus 30 equals 714
G 14 hr. 25 min.	3,500	792 plus 30 equals 822

AVERAGE FOR ALL FREIGHT SERVICE.

Time	Water	Coal
4 hr. 55 min.	3,500 Gal.	759 lb.

SAVING FOR TEN ENGINES WASHED OR WATER CHANGED DAILY.

47½ engine hours @ \$50 per day.....	\$100.00
3,500 gallons of water @ 6 cents per 1,000 gal.....	2.15
7,590 lbs. of coal @ \$6.91 per ton.....	26.10
Total	\$128.15
Less interest and depreciation on \$10,000 investment.....	7.56
	\$120.59

ing facilities, firing up methods and steam pressure on roundhouse blower line. For washing the boiler effectively, quickly and without damage, the use of a hot water system is imperative. To illustrate the possible saving in time, a table is shown covering actual results daily obtained, as compared with the previous system of cold water washing.

With the hot water system the boilers are washed with water at pressure of 125 lb. and at a temperature of 150 deg., and are filled with water at a temperature of from 212 deg. to 215 deg. Consequently, when the boilers are filled the water is already beginning to make steam. Another item to be considered is that during the blowing off and filling periods the roundhouse is not full of steam and noise, which enables men to work about the locomotive in comfort and safety.

Firing up.—After the boiler is washed and filled, the proposition is to get steam as rapidly as possible. Loading a tank with scrap wood is expensive, time wasting and dangerous. Expensive, in that, even though the wood used is scrap, much better results can be obtained otherwise. Time wasting, in that it takes time to throw it on and interferes with the hostler, or others, getting on or off the engine. Dangerous, in that it is liable to fall off, catch on

the facilities named can, and should be, installed in every terminal where 25 or more locomotives per day are washed and turned. Only those who have been "up against it," as the saying is, realize the enormous loss of time due to poor outside facilities and old fashioned low pressure cold water boiler washing methods.

LOCOMOTIVE TERMINAL DELAY

There are terminals where locomotives stand from six to ten hours waiting their turn on the cinder pit, all of which time could be conserved and utilized to handle trains over the road. An increased force under such conditions would necessitate sufficient men to handle the peak load and, consequently, entail a loss during slack hours, even if men were available. At the present time, however, when labor is at a premium, facilities—under which term can be included everything such as machinery, tracks, pits, etc.—must take the place of hand labor if results are wanted.

In a paper* read by G. S. Goodwin before the Western Railway Club in February, 1915, on "The Value of a Locomotive," he gives the average roundhouse detention as 6 hr. 49 min. At a terminal the writer has in mind where the facilities named above obtain, the average time locomotives are held at terminals, including those receiving the monthly, quarterly and annual Federal test, runs from 4 hr. to 5 hr. 15 min., figuring from the time the locomotives reach the terminal until again set out ready for service. This shows a saving over Mr. Goodwin's figures of not less than 1 hr. 30 min. per locomotive, taking the longest detention into consideration. Another means for decreasing terminal engine hours is by turning the engines promptly at intermediate terminals and send them back with fresh crews.

In justice to those who do their railroading in cold countries, it should be stated that the figures herein shown apply where weather conditions are ideal, in that, at no time, is the weather so inclement that the inspection and other details mentioned cannot be handled outside.

* See Railway Age Gazette, Mechanical Edition, March, 1915, page 118

METHOD OF SUPERVISING RUNNING REPAIRS

BY E. J. HARRISON

Superintendent of Motive Power, Buffalo, Rochester & Pittsburgh

We have organized gangs in our engine houses under a gang leader, which consist of from two to six men—that is, we will have a gang handling driving box work, one shoe and wedge work, one crosshead and piston work, one spring rigging, one firebox and flue work, one tender work, etc.—and it is working out very successfully. We have also placed at roundhouses a man that we call "final inspector." When a locomotive arrives at the cinder pit it is inspected by a man who reports the repairs needed on Form 829-A (Fig. 1)

KEEP ENGINES ON THE ROAD

BY F. W. TAYLOR

Superintendent of Motive Power, Missouri, Kansas & Texas

The "slogan" at roundhouses or terminals should be, "Keep engines on the road and stop failures," and no locomotive should be despatched unless the foreman is reasonably sure it is in condition to make a successful round trip.

The cleaning of fires and coaling should be done in the shortest possible time. The filling of sand boxes should be done at the same time the tank is filled with water.

Hot-water washing out and filling up plants will increase the life of the boiler, reduce boiler repairs and shorten the time to raise steam and should be in every terminal.

Locomotives should be turned on power driven turntables.

Each terminal should be equipped with either oxy-acetylene or electric welding and cutting outfits, with a competent man to operate them.

Labor saving devices should form a part of every roundhouse equipment.

The firing up of locomotives should be handled with despatch, and for this there should be an efficient blower line.

The enginemen can materially assist in the quick turning of locomotives at terminals by making clear work reports.

The little repair jobs on locomotives should receive prompt attention, so that they will not grow and multiply until they become big enough to hold the locomotives out of service.

Last but not least, a thoroughly competent and resourceful foreman should be placed in complete charge of all roundhouse work.

THE INDIVIDUAL IS THE VITAL FACTOR

BY JOHN C. MURDOCK

Allston, Mass.

The most important and patriotic duty a man can perform for this country at this time is to work just as hard and as steady as he possibly can, and at the same time keep in good spirits with the thought of having applied himself to something worthy of a supreme effort.

My experience with enginehouse work has been, that many things are done to satisfy the particular whims of some people. For instance, in ordinary times valve gears have been taken down and a small amount of slack taken up, and main rod and side rod brasses have been reduced and renewed, when they both may have gone longer, etc., because some person wanted his engine fixed up.

In extraordinary times supervision is the mainstay and the job should be run from the top down instead of from the bottom up. In making a supreme effort the persons in charge must be immune to criticism and work along with confidence and feel that every knock is a boost. The different members of the organization must get close together and pare down the individual wants and hobbies.

The engine despatcher should make a personal effort to so switch the locomotives that those will get inside first which are wanted first and in this manner keep the repair force working the locomotives out in rotation, thereby saving time lost in shifting from one locomotive to another.

The present situation calls for special exertion of the individual; each and every man concerned must make himself a committee of one to see that this is done. Everyone from the top down to the bottom should have this in mind and in running against "knocks" they should not let anything get in under the skin.

The railroads are the arteries of this country, transporting the potential power of its natural resources to the place where it will do the most good, and every individual should see to it, insofar as he is able, that he assists.

The slogan of today on the railways should be: "Work hard and everything else will take care of itself." This will be particularly true where there is plenty of supervision. Also—"Have confidence in your superior officers."

INSPECTION AND WORK REPORT, LOCOMOTIVE

INSTRUCTIONS: Each locomotive and tender must be inspected after each stop at any point and reports made on this form, whether or not the engine is out of service. Proper explanation must be made herein for failure to make any defects reported, and the form approved by locomotive inspector and superintendent for service. If there is not sufficient room on the back fill out the next one for the location.

INSPECTED BY ENGINEER AT	DISPOSITION OF EACH ITEM OF WORK REPORTED		
	DEFECT NOT REPAIRED	DEFECT REPAIRED	DEFECT REPAIRED BY OTHER PERSONS
REPAIRS NEEDED			

Condition of injectors, right _____ left _____ Water Gauge _____ Gauge Glass _____

Piston Ring Packing _____ Valve Stem Packing _____ Brakes, Engine _____ Tender _____

Main Pressure Pressure _____ Piston, Crank and _____ Piston, Safety Appliances _____

Safe Valve Lifts at _____ Pounds, Safety Appliances _____ Head Light _____

Bell Signal _____ Sounding _____

Inspector _____ Terminal _____ Date _____

Fig. 1.—Inspectors Repair Report.

and this form is then sent to the roundhouse clerk by a boy whom we call a "runner." The clerk then copies the work in the work report book that is reported by both the engineer and the inspector. Each individual item of repairs is made out on a work order, Form 830 (Fig. 2), which the boy takes to the roundhouse foreman who distributes the work to

WORK ORDER No. _____ LOCOMOTIVE No. _____ PAGE _____ IN BOOK FORM 829

ENGINEER OR INSPECTOR _____ TERMINAL _____ DATE _____

THIS WORK DONE BY _____ DATE _____

WHY NOT DONE FOREMAN _____ DATE _____

Fig. 2.—Work Order for Engine Repairs.

the gang leaders. After the work is done the slip is given to the "final inspector" who determines whether it is properly done or not, and he does not "O. K." it unless it is properly done. If it is improperly done he calls the roundhouse foreman's attention to it, and he gives it immediate attention. After the work is "O. K." and the slip is signed by the "final inspector," it is then delivered to the roundhouse foreman. This gives him an opportunity to see the slip before the work is distributed and after the work is completed. He then notifies the train despatcher that the engine is ready for service. At the end of the day these slips are laid on the general foreman's desk.



REPAIR THE CARS AND KEEP THEM MOVING

THE SUCCESS with which the railroads will meet the demand for freight cars during the remainder of the winter depends to a very large extent upon the despatch and thoroughness with which the cars are repaired and put through the terminals. During the past year only about 80,000 freight cars have been ordered for use in the United States and Canada. This is the smallest number ordered during one year since 1908. The situation is serious and demands that the greatest efforts be made to keep what cars there are in service and to keep them moving. With governmental control of the railways help is expected and without doubt before this article is read by many positive steps will have been taken to increase the freight car supply. Whatever assistance is given will not be felt for a few months at least and in the interim the car supply must be maintained at a maximum. The car repair and inspection forces can contribute very materially to this end.

REPAIR CARS PROPERLY AND PROMPTLY

Late in the spring the Executive Committee of the Special Committee on National Defense of the American Railway Association, about one month after its formation, issued an appeal to the railroads requesting that the number of freight cars under repair be reduced. This had its effect and an improvement was shown in the following months. With the tremendous business, however, and the shortage of labor there have been tendencies for the roads to neglect the smaller defects. Com-

menting on this fact J. C. Fritts, master car builder of the Delaware, Lackawanna & Western, says:

"One of the most important thoughts is that conveyed by the old saying we have all heard: 'A stitch in time saves

nine.' At this time, when cars are so badly needed, along with the scarcity of labor and material, the general tendency, no doubt, will be to load cars, if they are able to handle the lading with any degree of safety, without making the small, minor repairs. This is a very serious mistake and will eventually result in the cars being taken in requiring heavy repairs. In reviewing my 29 years' experience in car maintenance, there is nothing so detrimental to the maintenance of equipment as to neglect the making of light or minor repairs in time to save a greater expense a little later on, as well as the loss of the use of the car."

Speaking further on the general subject of car conservation, he says:

"All railroads should endeavor to keep at the work of reinforcing some of their older types of cars by applying steel underframes and such reinforcements as in their judgment might be economical. I

realize, of course, that in many instances it is hard to obtain material, as well as labor, but if every railroad throughout the country would do as much of this as it is possible for them to do, the general effect would, no doubt, be felt, as every time a weak car is made strong it increases the efficiency as a whole just that much.

"The railroad companies should put their oldest and weak-

"ALL transportation systems . . . shall be operated as a national system of transportation, the common and national needs being in all instances held paramount to any actual or supposed corporate advantage. All . . . rolling stock and other transportation facilities are to be fully utilized to carry out this purpose without regard to ownership."

This is an extract from the first order issued by Director-General McAdoo. It will solve many problems for the car department forces. It is a command that many will be glad to obey. It should eliminate many misunderstandings regarding repairs to foreign cars. It makes it possible to settle many controversies promptly. There is now no "foreign car" except in name. The sole problem is to use the rolling stock to the fullest extent, holding the national needs "paramount to any actual or supposed corporate advantage."

est cars in special service, wherever there is an opportunity to do so. In making this statement, I have in mind observing on a certain road new cars, of the strongest construction, being used in ash-pit service, while the older and weaker cars were being handled in the heavy trains. In this instance, I believe very much better results could be obtained if the older equipment had been used for this special service and the strong, sturdy cars used in the regular coal traffic."

T. J. O'Donnell, arbitrator of the Niagara Frontier Car Inspection Association, calls attention to the necessity of making permanent repairs:

"We should all realize the necessity of making permanent repairs, especially to the body of the car when conditions and circumstances will permit, rather than 'toggle' the car up for the load that is in it at the time. This would apply mostly to sills, ends, door posts and other items where the load seems to catch the car more particularly. We should give particular attention to the defects on the wheels and all do our share of this work so that it will not all fall on a certain few repair points.

"The upkeep and maintenance of air brake equipment is very important and should be kept in our minds at all times. They should be given best of attention, especially on high-class freight such as stock, refrigeration and cars that are run for long distances."

DESTROYING CARS

Another master car builder tells of the extent to which his road is going in the matter of demolishing old cars. A short time ago the following instructions were issued:

"On account of the high prices and the inability to receive new equipment or material to rebuild cars, it is necessary that the practice of destroying cars badly damaged in wrecks (which was good practice in normal times) be changed until the end of the war or until conditions are more nearly normal.

"Any wood, composite or steel cars (except a few low side steel gondola or cinder cars) which are damaged in wrecks must not be burned, but must be brought into the shops and repaired. If all of the wood work is broken and destroyed, the metal parts must be loaded up and brought into the shops without dismantling, and the car rebuilt using the old metal parts.

"If the body of the car has been burned, the metal parts must be brought to the shop without dismantling and used to rebuild the car.

"The above includes box, coal, gondola, flat, stock, produce and refrigerator cars and all work and service cars, snow plows, etc."

DELAY TO FOREIGN CAR REPAIRS

On August 17, a circular was issued by the executive committee of the A. R. A. Committee on National Defense calling attention to the large amount of unnecessary delay in repairing foreign cars. When a railroad car shop repairs a freight car belonging to another road, and has to send to that other road for material, it has to bear not only the cost of the per diem charge on the car while it is waiting, but also the loss of the car in service; and in the present scarcity of cars this is a serious item. One large railroad found that there was an average delay of 14 days, from the date of its orders for material from owners, to be used on foreign cars, to the date the material was shipped; and a further delay of 31 days (average) from the time the material was shipped until it was received. These figures, very likely, may show the general average throughout the country.

Attention was called to the fact that the Master Car Builders' rules permit the use of unstandard parts under certain conditions, provided the car can be made safe and serviceable; and the association has recommended and urged

members to take advantage of this provision of the rules.

A. M. Darlow, assistant to the president of the Buffalo & Susquehanna, referring to this same thing, says:

"Cars are held at repair yards for long periods awaiting the receipt from the owners of manufactured and special articles standard to those cars. These cars might be repaired and made safe to run without such delays by the use of such material and parts as are available. The American Railway Association recommended this practice but it is not being followed in some cases."

A superintendent of motive power of a road in the West finds occasion to make a similar criticism. He says:

"Further, car equipment should not be held by foreign lines for the owners to send repair parts. Any amount of equipment is tied up on foreign lines for weeks and months waiting, possibly, for some small repair part that could have been made and applied to the car and the car put in service with a minimum delay, were it not for the fact that there is a rule that says wrong repairs shall not be made to your neighbor's car without your neighbor being reimbursed for the cost of correcting such wrong repairs."

RUN, REPAIR OR TRANSFER

The transferring of loads has become a very live issue at many interchange points. One superintendent of motive power suggests that—"The ancient rule of 'Run, Repair or Transfer' should be adopted, it being understood that the receiving road, if it decides a transfer should be made, should make it at its own expense. If this were done much less transferring and holding of equipment would obtain."

Mr. O'Donnell says that one of the greatest improvements in the car situation could be made by selecting more carefully the equipment for loads at the original loading points. This would eliminate the transferring of load en route, which with the present labor shortage causes a serious delay. He speaks particularly of the manner in which lumber and heavy timber is loaded onto open cars such as those of the flat and gondola types: "A great deal of delay and expense could be overcome by a little more care exercised at the original point of loading by using the long timbers as the base of the load when possible to do so and putting the shorter timbers on the top, rather than throwing the timbers in the car promiscuously, which causes extensive shifting and weakens the side stakes and in many instances causes the transfer of the entire load."

In speaking at a recent meeting of the Niagara Frontier Car Men's Association, he said that the number of loads transferred in all yards in the Buffalo territory averages about thirty a day or 900 a month. Every means is being taken to reduce this number and get the car through the terminal without disturbing the lading. Many roads are splicing center sills, rather than attempt to hold up the freight and lading.

Other members of that association speaking on this subject called attention to the fact that as the cars were being much more heavily loaded at the present time that considerable more time was taken to transfer the loads. Some suggested that an examination be made by the immediate superior of the inspector to determine whether or not it is absolutely necessary to transfer the loads the inspectors mark for transfer.

The entire matter of interchange is one requiring the exercise of a great deal of common sense particularly at this time. The roads at the interchange points must co-operate and do everything in their power to forward the loaded cars onward in their journey. So absolutely necessary is this that the Commission on Car Service, which is a sub-committee of the Railroads' War Board, printed in bold face type at the bottom of its first general order:

In all cases, keep the cars moving and settle differences of opinion afterwards.

SUPPLYMEN TELL OF EXPERIENCES IN RAILWAY OFFICES

How to Reach the Big Boss and make a Favorable Impression upon him



IN ANOTHER ARTICLE in this issue chief clerks in the railway mechanical department tell of their experiences with supplymen and make suggestions looking toward closer co-operation between, as well as conservation of, the time and energy of both the supplyman and the railway officer. Supplymen sometimes feel hurt because of their reception in railway offices—and not always without cause.

At our suggestion a dozen or more successful supplymen have given frank expression concerning their experiences in railway offices. The following extracts from these expressions may be studied with profit by supplymen and railway officers:

I GET DOWN TO BUSINESS

Since real business men evade the habit of taking their business affairs home, the same should apply to the supplyman who takes baseball, golf and other diversions into his customer's office; if he will be more prompt in getting to the business in hand, it will work out greatly to his advantage, as well as to that of the officials on whom he calls. For instance, the peddler enters, is seated, and occupies the first ten minutes in discussing the weather. If a few railroad officials would answer to, "Isn't this a wonderful day?" by "I have heard it so spoken of," several minutes of this discussion would be eliminated; but good nature is always penalized, and the official resolves that next time he will either be out or in conference.

II

DAY OF DISAGREEABLE RAILWAY OFFICER PASSING

I recall but one instance where I received a report from any of our representatives in regard to any but the most cor-

dial receptions they have received from purchasing agents and other railway officials upon whom they are calling continually.

I think the day of the disagreeable railway official is passing and the railway men who receive the representa-

RAILROAD OFFICERS and foremen are always busy. In these days they are driven to the very limit to keep things going. Supplymen should remember this.

On the other hand, the railroads were never so greatly in need of labor-saving and capacity-increasing devices and equipment, or never so hard pushed for material and labor.

The interests of railway officers and supplymen are identical—to increase railway efficiency and capacity and keep the transportation machine going.

To get ideal results, therefore, each side must have a real regard for the interests of the other. Common courtesy and good judgment must be exercised by both parties. Both the sales managers of railway supply companies and the railroad officers should emphasize this to their subordinates.

tives of the large industrial concerns are business men with the full sense and realization of their problems and understand that it is to their own best interest, and the interests of the railroad companies which they represent, to cut out the high-handed important way which some of them have had in the past to their own disadvantage.

III

TROUBLE GETTING THE ORDER

It has seemed to me that the supplyman's reception in the railroad man's office has usually been based on courtesy and an endeavor to conserve the supplyman's time as much as the railroad man's. The very few deviations from this which I have heard of are of such small consequence that they do not need to be considered. In other words, I do not think the supplyman's position is difficult as far as his reception and use of his time is concerned; the only difficulty I

have found is "getting the order."

IV

"HOT ALL OVER"

There are a few officials who evidently feel that supplymen enjoy "warming their heels" in the outer office and proceed to let them wait there until they are "hot all over." There is no question in my mind but that the most satisfactory arrangement is the setting aside of certain hours for the reception of visitors, and to see, except in extreme in-

stances, that supplymen are promptly received during such hours.

I have in mind one railway mechanical department official who has a card in his outer office announcing that visitors will be received during certain hours. It is seldom possible for an interview during this reception period owing to committee meetings, dictation and other matters which, it would appear, could just as well be taken care of at other than the time set aside for supplymen.

I am not losing sight of the fact that a few of the supply fraternity feel that as long as they are cordially received, it is necessary to talk on every conceivable topic and to continue until the subject shows signs of uneasiness. This practice tends to keep others waiting unnecessarily, and should be discouraged.

V

REMEMBER RAILROAD OFFICERS ARE BUSY MEN

I feel that the blame for what might be considered improper treatment of the supplyman lies almost always entirely with the supplymen. Where this condition does not apply directly, it does indirectly; that is, discourteous treatment may sometimes be meted out where it is undeserved by reason of familiarity with and impositions that have been made upon a railway man by some other untactful supplyman.

I have never experienced any difficulty in obtaining an audience with any railway man with whom I have had any business to transact, nor have I experienced any difficulty in transacting business with the man after I obtained the audience. I have had difficulty, and could have imagined myself discourteously treated, when I have attempted to take up a busy railroad man's time with discussions of the weather and the war.

Further, I have always found when I had any business to transact in any of the railroad offices, that the man upon whom I was calling gave me the impression that he had business to transact with me, and we were able to arrive at a fair settlement of the question without difficulty. A fair settlement does not mean that it was always settled entirely my way, but that concessions were often made on both sides.

VI

CHIEF CLERKS AT FAULT

First, I believe a great deal of delay is caused to supplymen by chief clerks and their assistants not promptly advising the railway official of the supplyman's presence and desire to see him. I have often noticed a supplyman who is not so well acquainted, go into an office, and the chief clerk will say, "How do you do?" take his card and continue dictating letters or continue other matters for thirty minutes, or even longer, before taking his card in to the official. I have seen this done when I knew the official would have seen the man immediately upon receipt of his card.

Second: Another cause of delay is that some railroad officials do not seem to realize that a supplyman usually has a great many calls to make in a day, and after making an appointment with a supplyman, he does not make a memorandum of it or make any effort to be prompt, although they expect a supplyman to be "Johnny on the spot."

There is no doubt but that railroad officials have to look over a great many devices and hear a great many talks which are not and cannot be interesting to them; I believe this occasions their getting into the habit of listening with their mind on other matters and not giving the supplyman's talk the attention and consideration deserved. This results in reducing the efficiency of the supplyman, and when he sees he is not being given the proper attention he wastes a great deal of additional time in going over the matter the second time, trying to get his attention.

A great many offices have certain hours for visitors. While

this works out very nicely for the railroad men you will readily appreciate that if every railroad official, for instance, set the hours from 10 to 3 for calls, the supplyman would only have a three- or four-hour day at the most.

VII

SUPPLYMAN, STUDY YOURSELF!

I firmly believe that I hit the nail on the head when I state that the criticism mentioned in your letter is very largely due to salesmen who are not temperamentally fit for the position of salesmen; and, secondly, salesmen offering for sale to the railroads a product which in actual practice has not the real merit which the salesman has convinced himself it has.

In all lines of trade you will find men in various capacities who are unsuited for the particular jobs they fill. In all lines of trade you will also find the disgruntled man who has not made a success of anything he has undertaken. And, generally speaking, the reason for his non-success is that he does not sufficiently understand his own temperament or the work that he has undertaken.

This type of man does not lay the blame on himself, where it should rest, but, on the other hand, blames other factors which he imagines are working against him, and which factors generally are entirely of his own making, although he does not recognize his own responsibility in working against himself, the psychology of the human mind being very largely responsible for his imaginary troubles.

If my diagnosis is correct, in order to reach a solution of the question referred to in your letter should not the matter be approached from a different angle? For the salesman to look within himself and endeavor to correct what is wrong there, would be more to the point than to try to correct a practice that may not exist. The salesman should then be certain that his material is mechanically correct and that it answers a demand.

VIII

AUTOCRATIC OFFICE BOYS

Assuming that the supplyman is a competent, experienced person, selected on account of his qualifications and experience, it should be conceded that he will appreciate the fact that the railway officer is a busy man and is often called away from his office to attend to the administrative features of his position, which would indicate that many important matters await his attention when he arrives at his office after a trip, and it is, therefore, not desirable to be interrupted by callers. The experienced supplyman will make due allowance for these conditions and conduct himself accordingly. However, inasmuch as the supplyman represents a company handling materials, the use of which is beneficial to the railroad company, he should be given opportunities for inspection and observation of his materials in use in a manner that will be beneficial to the railroad.

Considerable improvement could be made if there was a more prompt response to his approach by the use of his calling card. In many instances the chief clerk to the railway officer, if he has the authority and support of his chief, could arrange for this courtesy to the supplyman, thus giving him the opportunities he requires without any appreciable delay. In cases where it is necessary for the supply men to have a personal interview with the officer in charge a considerable saving in time for the supplyman could be effected by giving him an opportunity for a few minutes' conversation, during which he would present his case as quickly as possible.

Doubtless, there are some instances where the supply man is given a reasonably early opportunity to make a prompt and graphic presentation of his subject, but in the majority of cases he is compelled to wait a considerable

length of time at the mercy of the autocratic office boy before he is admitted to the office, which causes him serious inconvenience and delay in covering the territory contemplated by his company. In some cases the railroad officer does not give consideration to the delay and expense incident to the supplyman being compelled to wait over another day for an appointment.

IX

EXPERIENCE IN PURCHASING DEPARTMENT

When one considers the immense amount of work that goes through the purchasing department, in some instances consisting of a vast amount of detail which requires constant supervision and watchfulness, one cannot help but feel that he is receiving quite a little consideration to be given a hearing, even allowing that the calls are made during the specified hours set aside for the reception of visitors.

You will appreciate the fact that where there are several callers in the reception room, all waiting to see the purchasing agent, it might appear a long time until the turn for the seventh man came around. No doubt when the victim happens to be No. 7 or No. 8, as the case may be, in successive calls on the same day or week in different places, the time lost is considerable, but if one will note the time given to each individual one cannot help but arrive at the conclusion that the purchasing department is handling the visitors, on their individual calls, as expeditiously as possible. My remarks are based on my experience in the position of No. 7, and sometimes No. 10 or No. 11, and so rarely have I had reason to find fault with the lack of courtesy or consideration, that I feel as though it is a negligible quantity.

X

DON'T BE OVERBEARING

In our line of work, my duties require me to visit perhaps all of the mechanical officials on all of the Eastern railroads, also a large number of transportation officials, and, in a large number of instances, I regard these officials, not only as business acquaintances, but as personal friends, and am so regarded by them. I find that by adapting myself to circumstances which present themselves on each individual railroad which I visit, using patience, and not being overbearing, but courteous, that I am treated in about the same manner by the other fellow.

XI

OBJECTS TO WARMING A CHAIR

As a salesman, I believe in my product, and having made a study of its application, I start out to introduce it where I know it can be used to advantage and where I would adopt it myself, if I were the official in authority. I may have become over-enthusiastic regarding my own devices; but I am the average railway supplyman, and would not be handling them unless I were sure of their merits.

Frank and open discussion will bring out the merits or demerits not only of my own, but of my competitors' products. I may not be able to convince the railroad man and land an order; but if we are the right kind of humans, we both profit by such discussion. To be turned down without an opportunity of fairly presenting the proposition on its merits is unfair to all concerned. I realize, of course, that it takes time to see the supplymen as they come, and that there are many important things to be done; but how better can a man improve his time than by familiarizing himself with worth-while devices which will tend to increase efficiency and economy?

Could we properly conduct our business by correspondence, the frequent calls of the supplymen would not be necessary, and the time of both railroad and supplyman would be conserved. It is a fact, however, that the supply-

man must go out and carry his own message; because letters and literature do not bring about the desired results. Selling letters containing most interesting and valuable information usually remain unanswered, and it is very seldom that any serious attempt is made by the railroad man to come back with a letter, discussing the various points or giving real reasons for not being interested. The railroad man makes it necessary for the supplyman to call on him, and should grant an audience. If the railroad man is busy, and it is not convenient for an immediate interview, let him say so and make an appointment for some other time. He should not keep the supplyman warming a chair outside for an indefinite period, and then tell him he is not interested and too busy to discuss the subject.

XII

"BULLDOZING" THE SUPPLYMAN

Our experience has been that it depends considerably on the calibre of the railway officer as to how supplymen are received in railway offices. There are many small calibre men filling big men's shoes. As an experience of this, we might mention an incident with a man in charge of the purchasing for one of the largest railroad systems in the country, formerly, until recent years, noted for its efficiency through the management at that time in charge of the system.

We received the usual form of inquiry for certain products such as we manufacture, and quoted price on our machines with a delivery which, at that time, was practically from stock. We followed it up, and a short time after called on the individual referred to, after seeing those in charge of the mechanical department who had approved our equipment and advised that our machines had been specified by their shop superintendents.

The reception we received from the individual was a very disagreeable one, and of a bulldozing nature, the whole trend of the conversation and abuse being the question of price. I listened until he finished with telling me that he had already placed the order with another manufacturer at a very much cheaper figure. We were positive the construction of the competitive machine was of a design which we had made many years before, and abandoned after experiment as being unmechanical, and we readily convinced their engineering and efficiency departments of this.

After the individual referred to had finished his tirade, we asked him if the business of that railroad was conducted on the basis of price, and if every one in his organization was hired because he was cheap, regardless of whether he had any ability or qualities that justified paying more to get results. I asked if he had investigated our machines, relative to the difference in price, and he said that he had not, that our price was higher than the other people's, and that he did not care to discuss the proposition further.

XIII

SUPPLYMEN AT FAULT

Based on personal observation, I know that there are railway supplymen who do not fully recognize the fact that the railway man's time is valuable, and who believe that the proper attitude toward the average railway man is one of patronizing interest. I do not say that there is not room for improvement in the way the railway officers receive railway supplymen. I believe, however, that there is greater room for improvement on the part of the railway supplymen than there is for improvement on the part of the railway officers.

XIV

SORE, BECAUSE OF LOST ORDER

We hear complaints from supplymen as to how they are handled by railway men whom they are attempting to sell, but we believe if you trace this down you will find in 99 per cent of the cases the supplyman criticises the railway man who does not purchase his article.

NEW LOCOMOTIVE ORDERS IN 1917

A Total of 7,642 for Both Domestic and Foreign Deliveries—The Largest Number in Seventeen Years



THE number of locomotives ordered in 1917, according to the figures compiled by the Railway Age, was the largest for the last 17 years. The orders totalled 7,642 locomotives, including foreign and domestic, large and small locomotives of all kinds. The output of locomotives as distinguished from orders placed during the same period was 5,446. This was not the largest production in the last 17 years but it has been exceeded only three times in that period, namely, in 1905, in 1906 and in 1907.

Table I, giving the orders for the year in detail, shows

Domestic—Including railroads and industrials in the United States and Canada:	
From builders	2,056
From company shops	648
Total domestic	2,704
United States Government:	
For service overseas	2,057
England	273
France	140
Russia	2,196*
Other foreign	270
Total foreign	2,881*
Total of all orders	7,642*

*Including the Russian orders for 1,500 locomotives now held in abeyance.

that they were divided as follows: Domestic, 2,704; for the United States Government for service with the American troops in France 2,057, and for foreign countries 2,881.

The domestic total, as will be seen from Table II, was

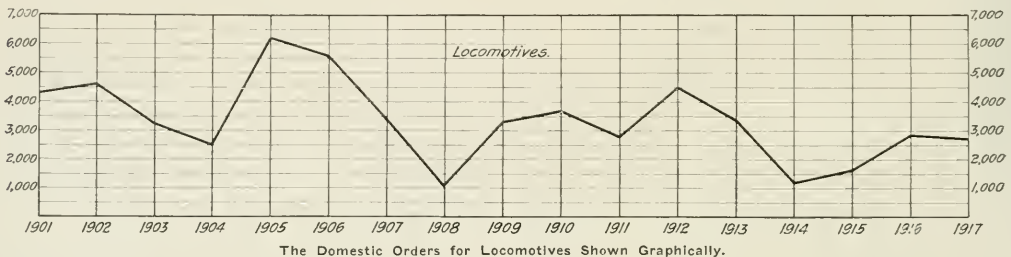

The Domestic Orders for Locomotives Shown Graphically.

considerably below the average for the last 16 years. For a time during the early months of 1917 it seemed as if the orders might exceed those for 1916, but our going into the war, the difficulty of getting material, the high prices and

the delays in deliveries resulting from the priority given to orders for the United States Government locomotives and those for our allies, served as a decisive check on the domestic market. The outstanding development during the year, says the Railway Age, was the government orders placed by the department of which Samuel M. Felton, director general of

TABLE II—DOMESTIC ORDERS FOR LOCOMOTIVES SINCE 1901

Year	Locomotives	Year	Locomotives
1901	4,340	1910	3,787
1902	4,665	1911	2,850
1903	3,283	1912	4,515
1904	2,538	1913	3,467
1905	6,265	1914	1,265
1906	5,642	1915	1,612
1907	4,482	1916	2,910
1908	1,182	1917	2,704
1909	3,350		

the American railways in France, is the head. These orders totaled 2,057, including 980 locomotives, weighing from 60 to 63 tons, a number of smaller and in most cases narrow gage steam locomotives and a very large number of narrow gage gasoline locomotives ranging from 4 to 23 tons in weight.

The foreign orders for locomotives totaled 2,881 as compared with 2,983 in 1916. The 1916 figures did, it is true, include 350 seven-ton gasoline locomotives for the Russian government which brought the 1916 orders on a tonnage basis down considerably. The 1917 figures, however, as will be noted from Table I, include the 1,500 Russian Decapod locomotives which have been held in abeyance.

These orders were distributed last November, 750 to the American Locomotive Company and 750 to the Baldwin Locomotive Works.

Orders were not definitely signed but arrangements were

made on the shop schedule to take care of the locomotives, and priority was given for them over locomotives ordered by American railways last May or March. They have now been put back on the shop programs but they have not been canceled and may yet be built.

These Russian orders, as a whole, comments the Railway Age, have proved at once a blessing and a curse for the American railway supply field and through it for the railways. The first Russian order for locomotives placed in June, 1915, when orders were scarcer than they had been at any time for the preceding six or seven years, was received

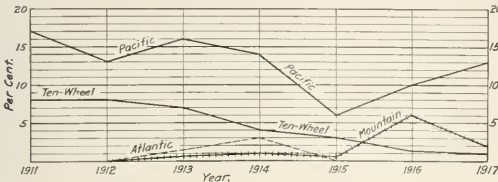

The Pacific, Mountain, Atlantic and Ten-Wheel Locomotives Shown in Per Cents of the Total Domestic Locomotives Ordered.

with something closely akin to joyfulness, and so were the others immediately following. The last two orders, that for 500 placed last July and that for 1,500 mentioned in the preceding paragraph, have simply had to be looked upon as an unwelcome duty, as something that America as one of the opponents of Kaiserism has been properly called upon to do for one of its brother opponents. But it is still true that these Russian orders were given priority over engines urgently needed for transportation requirements at home and with all the English, French, Russian and American government engines which were placed, the American orders were pretty well down on the builders' lists.

The locomotive situation since the holding up of the Russian orders has accordingly taken on a brighter aspect. The

TABLE III—CLASSIFICATION OF DOMESTIC LOCOMOTIVES ORDERED 1911-1917

	1917	1916	1915	1914	1913	1912	1911
Mikado	834	754	562	333	796	1,309	590
Switching							
Eight-wheel	110						
Six-wheel	282	730	221	201	638	821	443
Four-wheel	47						
Consolidation	60	63	194	166	833	858	577
Mallet	175	218	120	59	72	168	112
Pacific	342	278	102	174	566	594	486
Santa Fe	370	325	75	63
Ten-wheel	28	40	39	48	255	364	238
Mogul	13	28	12	24	42	61	127
Mountain or Mohawk	55	182	9	12	24	...	2
Atlantic	...	2	1	34	46	5	9
American	1	19	8	27
Electric	43	32	69	59	94	75	133
Other	188	238	168	73	103	252	406
Total	2,704	2,891	1,573	1,265	3,467	4,515	2,850

Russian order for 500 locomotives placed in July, 1917, is now almost completed, some of the locomotives having been shipped and others which were prepared for shipment are being stored. In fact, arrangements have recently been made whereby 200 of the Russian locomotives will be remodeled and leased temporarily to a number of American roads at a rental of \$50 a day. With the other 1,500 locomotives being held in abeyance, the American railroads can now look forward to receiving in the near future the power they put on order six months or a year ago, and specialty manufacturers have already received notification to ship the specialties for these orders.

The situation as to the orders placed by the United States government for service with the American troops in France has had much more to commend it than the Russian orders. Deliveries on the War Department orders have been better spaced, with regard, of course, to the shipping situation.

But even some of these locomotives will also be made available. Thirty have recently been loaned to the Pennsylvania, the Lehigh Valley, the Philadelphia & Reading and the Baltimore & Ohio, and arrangements are being made for the use of about 100 in all. But what has counted most on these orders has been the standardization and the fact that standardization began at the first stage of the game. Railway and supply men alike, reading the accounts of the delays over the standardization of the Liberty motor, the Liberty truck, the Enfield rifle, the Browning gun, the ships, have expressed their relief that in one industry at least the War Department was represented by a man who could take an instrument of warfare, in this case, a locomotive, and have it turned out, ready for shipment and a stand-

TABLE IV—THE LOCOMOTIVES BUILT

1917		IN PREVIOUS YEARS	
Domestic	2,385	Year	Locomotives
Foreign	2,861	1899	2,475
Total	5,446	1900	3,153
		1901	3,384
		1902	4,070
		1903	5,152
		1904	3,441
		1905	5,491
		1906	6,952
		1907	7,362
		1908*	2,342
		1909*	2,887
		1910*	4,755
		1911*	3,530
		1912*	4,915
		1913*	5,332
		1914*	2,235
		1915*	2,085
		1916*	4,075

*Includes Canadian output.

†Includes Canadian output and equipment built in railroad shops.

ard for a year's future production in 20 working days. As a result these U. S. A. Consolidation locomotives are keeping out of the way in the builders' plants and locomotives for American roads now have a clear path to completion and shipment.

THE DOMESTIC ORDERS

When the extraordinary conditions of the locomotive market, both as to prices and deliveries, existing during the greater part of 1917 are considered, there is nothing unexpected in a falling off in the number of orders placed for locomotives for domestic use during 1917 as compared

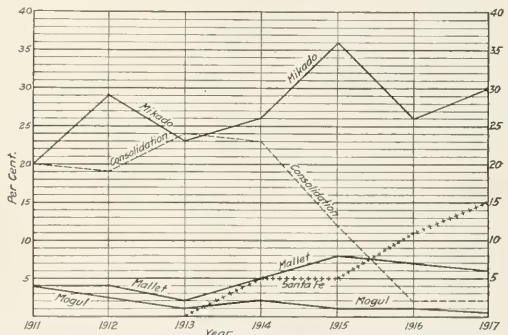

The Mikado, Santa Fe, Mallet, Consolidation and Mogul Type Locomotives Shown Graphically in Per Cents of the Total Domestic Locomotives Ordered.

with 1916. The significance of this reduction so far as it applies to the railroads, however, is more apparent than real. The reduction has taken place largely in the number of locomotives ordered for industrial use and the lighter types for railroad service. There is an actual increase in the number of locomotives of several of the heavier types for which orders have been placed. The falling off of available tractive

effort is, therefore, much less real than the figures for the total number of locomotives ordered would indicate.

Enough has been said, however, to indicate that the situation as to domestic orders during the past year has been bad. Builders and specialty manufacturers alike have been postponing orders periodically and railway men have had to be pacified with the information that deliveries have been held up for them on account of more urgent war orders. This situation is now being remedied, so that the outlook both for deliveries and production in 1918 looks exceedingly favorable. Whether additional orders will be placed in the next few months is a question. The fact that the government has taken over the railroads is looked upon favorably, and with the easing up in prices and the improved deliveries, the supply field is confidently expecting a large buying movement. Upholding this belief is the fact that many railroads have reserved space for the coming year. The Norfolk & Western's order for the Mallet locomotives reported this week in part takes advantage of such a reservation and the New York Central has had a reservation of space for 250 locomotives with the American Locomotive Company since last September.

In the detailed lists of orders given in the Railway Age will be found many orders of more than ordinary importance, very large orders having been placed by a considerable number of roads. Companies which placed orders for 40 or more locomotives were as follows:

Atchison, Topeka & Santa Fe, 130; Buffalo, Rochester & Pittsburgh, 55; Canadian Government Railways, 120; Chicago & North Western, 70; Chicago, Burlington & Quincy, 65; Great Northern, 90; Illinois Central, 154; Lehigh Valley, 61; Louisville & Nashville, 48; New York, New Haven & Hartford, 61; New York Central and associated lines,

150; Norfolk & Western, 51 (all of which were heavy Mallets); Northern Pacific, 65; the Pennsylvania Railroad, Lines East, 503; Pennsylvania Lines West, 100; Philadelphia & Reading, 65; South Pacific System, 130, and Union Pacific System, 100.

As far as the domestic orders are concerned it will be noted from Table III and the diagrams that there have been, even with the smaller total of orders placed, increases in the number of Mikado, Pacific and Santa Fe locomotives. The Decapod, a new development in domestic locomotive design, has increased in favor as indicated by its adoption by the Canadian Pacific and the Pennsylvania for heavy freight service. The number of Mallet locomotives shows, on the other hand, a decrease. There is also a considerable drop in the number of Mountain and Mohawk locomotives ordered, but this is merely the result of the New York Central's not having ordered any additional engines of this type since its big contracts for these locomotives last year. The most noticeable decrease in any one kind of locomotives was in switching locomotives; indeed the larger part of the decrease in the total is to be found in the light locomotives for railroads and industrial companies.

Of the steam locomotives ordered for railroad service in this country, that is excluding locomotives ordered for industrial or logging purposes, about 94 per cent were specified to be equipped with superheaters and approximately 80 per cent to be equipped with brick arches.

Special valve gears have been specified on 422 locomotives including 327 Baker, 90 Southern, and 5 Young. Mechanical stokers have been specified for 615 locomotives, including 133 Street, 337 Duplex, 100 Crawford, 30 Standard and 15 Elvin. The last is a new stoker which has just been put on the market this year.

THE FREIGHT CAR ORDERS IN 1917

The Total of 164,058 Compares With 205,368 in 1916—Domestic Orders Reached New Low Level

THE orders for freight cars in 1917, according to the annual statistical tabulations of the Railway Age, totaled 164,058, including 79,367 for domestic use; 18,844 for the United States war department for the American forces in France; 180 other cars for the United States government and 64,667 for export to France, Russia and other foreign countries. These figures are a considerable reduction from the totals for 1916 when 205,368 cars were ordered. The decrease is all to be found in the orders for domestic use, there having been an increase from 35,314 in 1916 to 64,667 in the foreign orders and the entirely new factor of orders for our own government. In fact, the domestic orders for 79,367 in 1917 compare with 170,054 in 1916 and are the lowest since the Railway Age began its compilations in 1901, with the exception of one year, 1908, when only 62,669 cars were ordered. The foreign figures, however, must not be taken at their full face value because they include 30,500 Russian cars, orders for which have been held in abeyance.

The passenger cars ordered total 1,167, including 1,124 for domestic uses, this figure also being one of the smallest since the Railway Age began its compilations in 1901.

Of freight cars ordered in 1917 about 43 per cent were for foreign delivery either for the United States Government or for its Allies. Of the orders for 79,367 cars placed by the railways in this country for domestic use about 21,000, or 27 per cent, were ordered to be built by the railways themselves. In number this slightly exceeds those ordered

to be built in company shops last year, but in percentage of total cars ordered, the ratio is about double that of last year.

The shop orders were placed during the early part of the year when the prices and deliveries of the builders were at their worst. Even with this large number of shop cars and the shortage of steel there were a much smaller number of the all-wood construction cars ordered than would be expected.

Of the nearly 80,000 cars ordered only about 5,000, or 6.2 per cent, were all-wood cars. This is in about the same proportion as last year and the figures for both years are of course much larger than the immediate previous years. As steel for the underframes became more available during the year less all-wood cars were ordered.

Of all the cars ordered there was a proportionate decrease in box and hopper cars and a proportionate increase in refrigerator, gondola, flat and tank cars over the preceding years. The proportion of all-steel, steel underframes and other kinds of equipment remained practically the same.

The freight car situation during the year has not been exactly favorable either with the railways or the builders, the prices having been so high that the railways have not dared to come into the markets. As a result the builders have been operating in some cases at as low as 50 or even 25 per cent of capacity and as one manufacturer has put it, "when there were orders there was a shortage of labor and material, or when there was material, a shortage of labor."

The United States Government orders for the forces in France have helped the situation considerably and it is to the credit of the authorities at Washington that the deliveries on these cars have been called for with full regard to both the shipping situation and to the situation in car builders' establishments.

The Russian orders for cars have not had anything like the effect on the car market that the Russian locomotives orders have had. There have not been large car orders

This would assist materially in relieving the car shortage. They have been handicapped throughout the year by the scarcity of labor and the delayed receipt of material. Even now if a large number of cars was ordered for immediate delivery, it might be necessary for the Government to assist in the matter of materials. A shortage of material not only delays the delivery of the cars but disrupts the shop organization and greatly increases the cost of the cars. In other words, the conditions must be stabilized if the car produc-

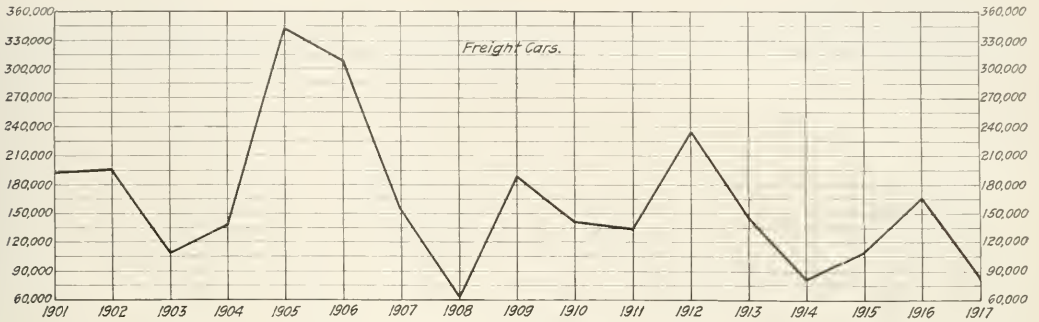

The Domestic Freight Car Orders Shown Graphically.

placed and there were not sufficient domestic orders to establish a conflict between deliveries on domestic and on Russian requirements, as was the case for locomotives, as mentioned elsewhere in this issue.

While 1917 may not have been exceedingly bright from the standpoint of freight car orders, the situation as to the

tion is to be sufficient to meet the needs of the country for new freight cars.

And this still omits from consideration the new developments at Washington, which, as noted editorially, have been received on the whole with favor in the supply field.

There were 151,401 freight cars built during the year, of

TABLE A—CLASSIFICATION OF FREIGHT CARS ORDERED DURING 1917

	All-steel	Steel frame and St. U. F.	Steel underframe	Steel center sills	Wood	Not Specified	Total
Box	3,253	9,300	3,634	7,902	518	652	25,259
Refrigerator	400	6,889	100	351	7,740
Hopper, including ore	9,737	1,100	86	50	300	11,273
Condola	5,597	3,925	2,864	2,702	13	104	15,205
Coal (not otherwise specified)	1,095	1	1,096
Stock	1,650	1,100	1,711	4,462
Flat	749	142	754	373	128	2,146
Tank	7,842	6	230	8,078
Caboose	217	9	300	50	70	820
Miscellaneous or not specified	1,284	666	100	1,096	142	3,288
Total	28,679	14,734	17,332	12,758	4,433	1,431	79,367

immediate future is exactly the opposite. The opportunities for the railways to obtain cars were never better than at present. With the material situation much better than it was last year at this time and with a smaller number of orders on their books, the car builders are in a position to give from three to four months' delivery, which is the condition

which 119,363 were for domestic use and 32,038 for foreign delivery. Of the 119,363 for domestic use, 12,273, or over 10 per cent, were of wood and over 11 per cent, or 13,488, were built by the railroads themselves. The total number built is a material increase over 1916 and 1915.

The fact that the domestic orders for freight cars were

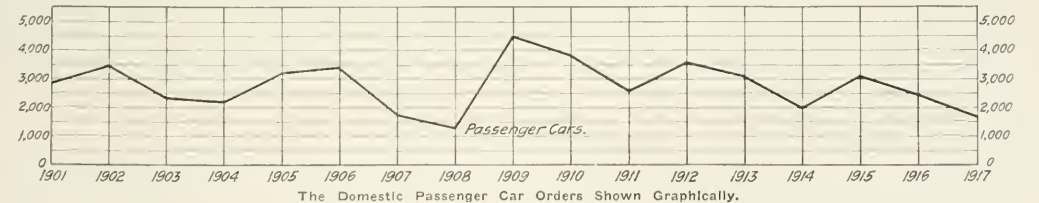

The Domestic Passenger Car Orders Shown Graphically.

in normal times. With a plant capacity of about 25,000 cars per month and with current orders to absorb this capacity for the next three months, one-fourth of which is for foreign delivery, the car companies could, if sufficient orders were placed, organize their forces for maximum full production and provide over 100,000 cars within the next six months.

so low, means that there were not many large or important individual orders. Orders for over 2,000 cars were placed by the following roads: Atchison, Topeka & Santa Fe, 2,450; Baltimore & Ohio, 2,450; Canadian Government Railways, 5,870; Chicago & North Western, 2,050; Chicago, Milwaukee & St. Paul 4,130 (nearly all in company

shops); Illinois Central, 2,575; Northern Pacific, 2,000; Pacific Fruit Express, 2,700; Pennsylvania Lines East, 4,329; Philadelphia and Reading, 2,230; Southern Pacific System, 5,443; Union Pacific System, 3,594, and the Union Tank Line, 2,200. The Western Maryland placed orders for 1,900 cars.

With all the decrease in car production and orders, the

TABLE I—THE FREIGHT CAR ORDERS IN 1917

Domestic—Including railroads and private car lines in the United States and Canada:	
From builders	58,443
From company shops	20,924
Total domestic	79,367
United States Government:	
For service overseas	18,844
For use in this country	180
Total United States Government	19,024
France	21,700
Russia	42,500*
Other foreign	1,467
Total foreign	64,667*
Total of all orders	164,058*

*Including the 30,500 Russian cars, orders for which are held in abeyance.

types of cars built during the year were not devoid of interesting features in their design. There has been produced an all-steel refrigerator car, and 85-ton capacity car with five hoppers, a 120-ton capacity coal car, a new type of self-propelled motor car and notable examples of steel passenger cars.

The all-steel refrigerator car was built by the Pennsylvania and is particularly interesting. The superstructure is virtually a shell within a shell, the inner lining being self-

TABLE II—THE PASSENGER CAR ORDERS IN 1917.

Domestic:	
From builders	1,005
From company shops	119
Total domestic	1,124
U. S. Government	6
Foreign	37
	1,167

sustaining and separated from the outside lining by four continuous layers of insulation extending from side sill to side sill over the top of the inner steel wall in one continuous piece. The cars are provided with basket bunkers, an insulated solid bulkhead and the space between the bulkheads is divided into three compartments. The Baltimore and Ohio and the Michigan Central have built refrigerator cars which are particularly well insulated, the insulation

TABLE III—DOMESTIC ORDERS FOR CARS SINCE 1901

	Freight Cars.	Passenger Cars.		Freight Cars.	Passenger Cars.
1901	193,439	2,879	1909	189,360	4,514
1902	195,248	3,459	1910	141,024	3,881
1903	108,936	2,310	1911	133,117	2,623
1904	136,561	2,213	1912	234,758	3,642
1905	341,315	3,289	1913	146,732	3,179
1906	310,317	3,402	1914	80,264	2,002
1907	151,711	1,791	1915	109,792	3,101
1908	62,669	1,319	1916	170,054	2,544
1917				79,367	1,167

being applied solid instead of with the usual intervening air spaces. These cars have the basket ice bunker with the solid bulkhead.

The Virginian 120-ton capacity coal car marks a most important step in the construction of this type of equipment. It is provided with the Lewis articulated six-wheel truck having a wheel base of 9 ft. The car weighs 73,900 lb. and with 10 per cent overload has a ratio of revenue load to total load of 76.4 per cent. It represents a design which has been given the most careful study, and contains many interesting features. The Pennsylvania 85-ton capacity hop-

per car, with five hoppers, has a light weight of 60,000 lb. and a gross cubical capacity of 3,228 cu. ft. as against 4,422 cu. ft., the maximum cubical capacity of the Virginian car is also noteworthy.

Among the passenger cars those built for the Delaware & Hudson and for the Erie represent real progress in the design of all-steel passenger equipment. The Delaware & Hudson cars are 72 ft. 8 $\frac{1}{4}$ in. long over body end sills, they weigh 138,700 lb. and have a seating capacity for 90 passengers. The Erie cars are interesting on account of the ingenious construction of the superstructure. The distribution of metal is such that a stiff construction has been obtained with a saving in weight. These cars are 70 ft. long over the body end sills; they weigh 110,900 lb. and have a

TABLE IV—THE FREIGHT AND PASSENGER CARS BUILT IN 1917.

	Freight cars	Passenger cars
Domestic	119,363	1,969
Foreign	32,038	31
Total	151,401	2,000
All-steel	61,115	1,874
Steel frame	29,310
Steel underframe	162,599	1,948
Steel center sills	153,195	2,007
Wood	8,317
	12,273	33
	151,401	2,000

COMPARISON WITH PREVIOUS YEARS

Year	Freight cars	Passenger cars
1899	119,886	1,305
1900	115,631	1,636
1901	136,950	2,055
1902	162,599	1,948
1903	153,195	2,007
1904	60,206	2,144
1905*	165,155	2,551
1906*	240,503	3,167
1907*	284,388	5,457
1908*	76,555	1,716
1909*	93,570	2,849
1910*	180,945	4,412
1911*	72,161	4,246
1912*	152,439	3,060
1913*	207,684	3,296
1914*	104,541	3,691
1915*	74,192	1,949
1916*	135,001	1,839

*Includes Canadian output.

*Includes Canadian output and equipment built in railroad shops.

seating capacity for 76 people, including 12 seats in a smoking compartment.

The prospects for improvements in design during the coming year are promising, particularly in freight cars. With the heavy demand for freight equipment new cars will be built and every means will be taken to get them promptly. With private and corporate interests being held subordinate to the nation's needs, the "standard car" will receive more serious consideration. A committee of the American Railway Association has been working on this problem for some time. Sample cars have been built and much study has been given the question. The committee has been unable as yet to come to an agreement. It is extremely desirable that the matter be settled as promptly as possible so that the designs can be used for the large amount of new equipment which must be constructed in record time during the current year.

ELECTRIC SOLDERING IRON.—A new type of soldering iron consists essentially of two high-resistance heating points, or electrodes, that become incandescent when the current passes through them. As the circuit is closed as soon as the points come into contact with the metal to be heated, the iron is said to become heated to the required degree the moment it touches the work. Besides, the heat is generated at the point of contact and at the spot where the heat is needed when soldering, brazing, or annealing. The iron operates at from six to sixteen volts and the points are made to carry current according to ratings of 150, 250, and 500 watts.—*Machinery.*

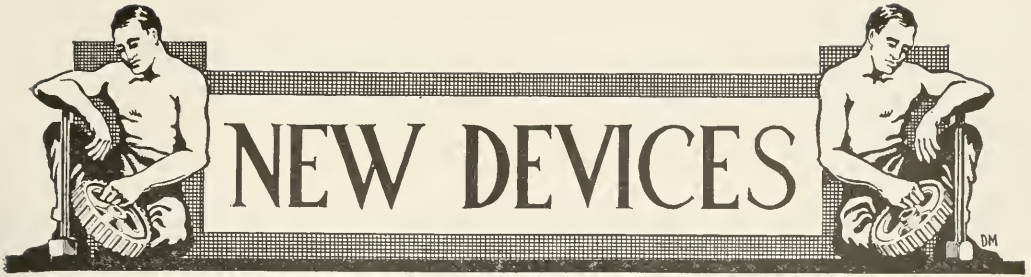

NEW DEVICES

LOCOMOTIVE FEEDWATER HEATING

There are probably but few roads in this country that have not experimented to a greater or lesser degree with some form of locomotive feedwater heater in an endeavor to reclaim some of the vast amount of heat that is liberated from a locomotive. One of the most tried methods is that of condensing the exhaust steam from the air compressor

have been made with various types of smokebox or waste gas heaters, but none have yet been developed to any great degree of success. One great disadvantage of the smokebox or waste gas feedwater heater is the large amount of heating surface required to raise the temperature of the feedwater any appreciable amount. This complicates the front end design and materially increases maintenance problems.

Of the waste heat passing out of the stack, that contained

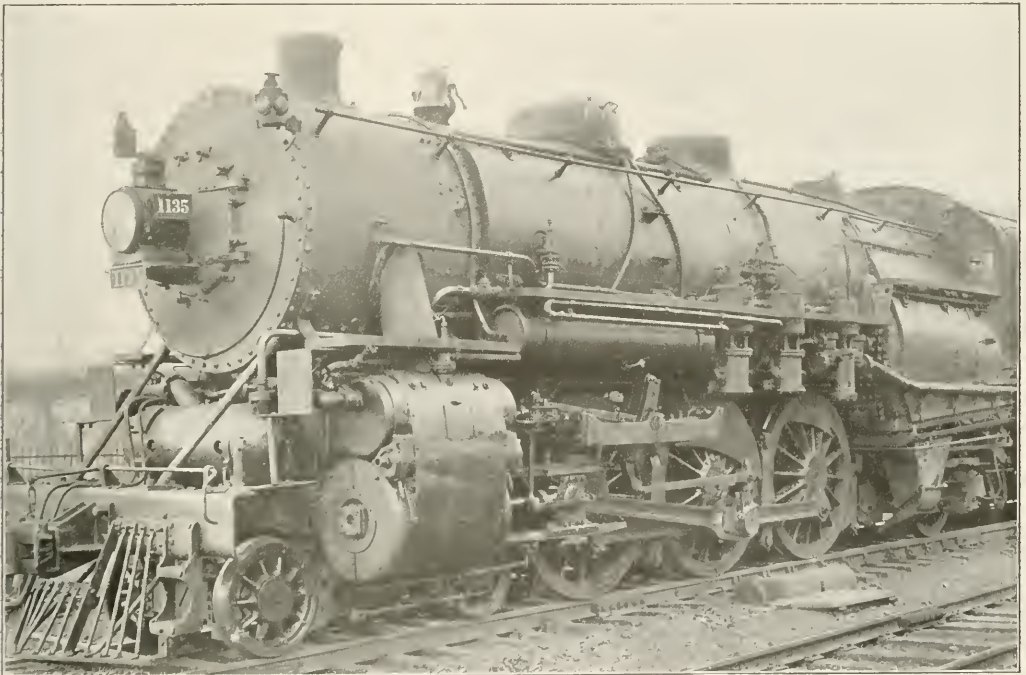

Application of Feedwater Heater and Steam Pump to a Locomotive

in a coil in the tank. This has been successful only as the engine crew has been able to keep the temperature of the tank water below the point at which it can be lifted by the suction of the injector. Obviously greater difficulty is experienced with this method of feedwater heating in the warm weather and the economies gained are much less than in the cold weather. When the water becomes too hot to be lifted by the injector, the difficulties are readily appreciated.

Other methods that have been tried consist of utilizing and conserving the hot gases in the smokebox. Experiments

in the steam exhausted from the cylinders is three times that contained in the exhaust gases. Furthermore, much more heat per unit of volume is contained in the exhaust steam than in the exhaust gases, which makes the exhaust steam the more desirable, as a smaller amount of heating surface will be required for the same temperature rise in the feedwater than were the exhaust gases used.

The system developed by the Locomotive Feed Water Heater Company, New York, uses the exhaust steam method of heating the water, the steam being taken directly from

the steam chest or the exhaust passage in the cylinder saddle, as shown in the illustrations. The amount of exhaust steam taken is not sufficient to interfere materially with the drafting of the locomotive, but a sufficient amount is taken to raise the feedwater temperature from 150 to 180 deg. The heater is located somewhere near the cylinders in order to reduce the length of passages between the cylinders and the heater. In the particular case illustrated, it is located

of the pump is regulated by a valve at that point. The exhaust steam from the pump passes into the heater to give up its waste heat to the feed water. The exhaust steam condensed in the heater passes through an opening in the bottom of the heater to a drain pipe that carries it to a point near the ash pan where it is drained to the track.

The pump was modeled after a Westinghouse compressor. The steam end is that used on a standard $9\frac{1}{2}$ -in. com-

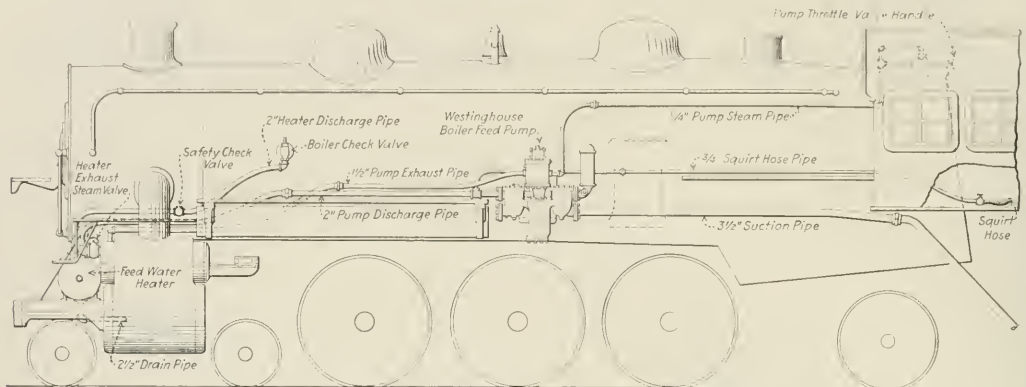

General Arrangement of An Exhaust Steam System of Feedwater Heating

directly in front of the cylinders. Pipes extend from each steam chest to the inlet connections of the heater. With this system the injector is replaced by an entirely new water pump which was developed for this particular work by the Westinghouse Air Brake Company. It may be located on either side of the locomotive, being applied in a manner similar to the application of an air compressor.

The diagrammatic view of the arrangement of the feedwater heating equipment applied to a locomotive well illustrates the system. The pump draws the water from the tank

pressor. The water cylinder is $6\frac{1}{2}$ in. in diameter and is double acting. When running at 80 strokes a minute the pump will deliver 6,500 gals. per hour. There are ten valves, five suction and five discharge, located in the chambers on each side of the pump. Each set of five valves is included in a valve deck which may be easily removed. Tests made with this pump have shown that 50 lb. of water and over are pumped per pound of steam used for operating the pump.

A sectional view of the heater is shown among the illus-

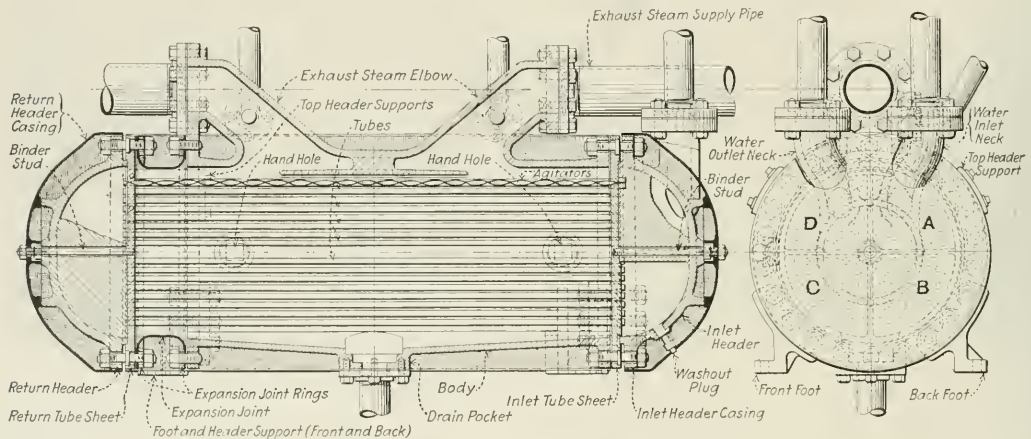

Section Through the Locomotive Feedwater Heater

through a $3\frac{1}{2}$ -in. suction pipe and delivers it to the heater through a 2-in. pipe. From the heater the water passes through a 2-in. pipe with a check valve to the boiler check. A $\frac{3}{4}$ -in. connection is made in the pump discharge pipe for the squirt hose, thus providing cold water for that purpose. The pump takes steam from the cab turret and the speed

trations. As indicated by the notations, the exhaust steam from the steam chests is admitted at the top, allowed to circulate around the tubes which contain the feed water, and passes out through the drain at the bottom. The water from the pump passes through the heater four times before it is delivered to the boiler. This is accomplished by

means of walls in the headers at the ends of the heater. The header at the right has three chambers formed by a wall extending horizontally across the header at the center and a vertical wall extending up from this wall. The header at the left has one vertical wall dividing it into two parts. The water enters the header at the right in the upper right hand chamber. It passes through the tubes in quadrant *A* to the header at the left. From there it returns through the tubes marked *B*, then back through the tubes marked *C* to the header at the left, thence through tubes *D* to the water outlet. By thus passing the water through the heater four times an equivalent length of pipe of 16 ft. is obtained from which the water will absorb heat.

One of the most important features of this heater are the agitators contained in each of the tubes in the heater. These are shown in the top row of tubes in the heater illustrated. They consist of a thin brass corrugated and spiraled strip of metal and their function is to so agitate the water as it passes through the tubes that every particle of it will come in contact with the hot tubes and absorb all the heat possible from the exhaust steam on the outside of the tubes. This agitation also serves to keep the tubes clean and free from scale. The higher the velocity of the cold water passing through the tubes the more violent the agitation and the greater the amount of heat absorbed by the water.

Two types of heater bodies are being used, one cast iron and the other steel plate. When a cast iron body is used the difference in expansion of brass and iron is taken up in a copper expansion joint forming one end of the body. When steel plate is used the difference is taken up by a flexible form of joint formed at either end of the body where it connects to the tube sheet.

DRILL GRINDERS

The importance of the correct grinding of drills cannot well be overestimated, especially at the present time when the price of drills is so high, and it is a patriotic duty to economize in the use of everything made of steel. A large

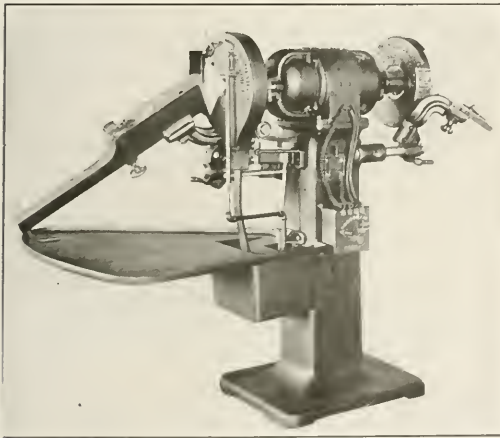

Motor Driven Drill Grinder

percentage of drill breakage and wear may be charged directly to imperfect grinding, and this detail of shop operation should not be neglected because it is apparently a minor one.

The illustration shows a W. N. L. New Yankee drill grinder made by the Wilmarth & Morman Company, Grand

Rapids, Mich., and it has several features which make it of interest to large users of drills. The grinder is motor driven, having a 1-hp. General Electric motor built into the head, and is particularly adapted to railroad work because all sizes of drills may be ground on the same machine. Drills up to 1/2 in. are ground dry on a fine grained wheel on one side of the machine, and drills from 1/2 in. up to 3 1/2 in., are ground wet on a coarser wheel located at the other side. No calipering is necessary with this type of grinder. Both lips of the drill are automatically ground to the same length, angle and clearance, and the only adjustment necessary is for the length of the drill.

MORRIS PLAIN RADIAL DRILL

A new 4 ft. plain radial drill has been placed on the market by the Morris Machine Tool Co., Cincinnati, Ohio. The machine will drill to the center of an 8 ft. 6 in. circle. The maximum distance between the spindle and the base is 5 ft. and the maximum distance between the spindle and the table 3 ft. 3 in.

The base of the machine is deep and well ribbed and provides a working surface 3 ft. by 4 ft. 3 in. There is a lubricating channel around the base which is so arranged that an oil pump can be attached if desired. The stump, which

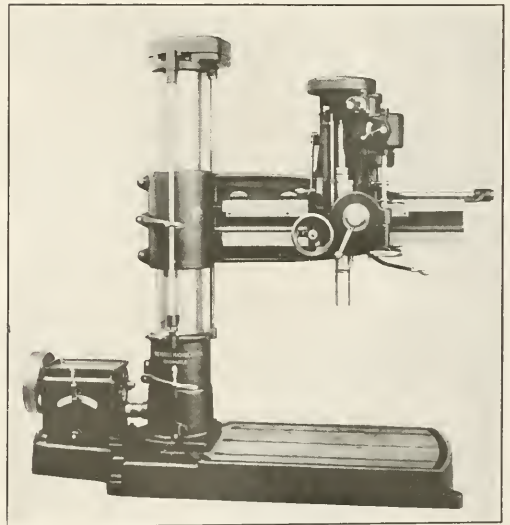

Morris Plain Radial Drill

is securely mounted on the base, runs through to the top of the column. At the top of the stump a combination annular and thrust ball bearing is mounted, which carries the entire weight of the column and the arm. At the bottom of the column there is a plain bearing on the stump. This construction permits the arm and column to swing about the stump with ease.

The arm is moved up and down on the column by power and has safety stops at the extreme positions. The head is heavily constructed with long bearings for the spindle. It travels on the arm on wide bearings and is driven by means of a hand wheel through reduction gears to a rack and pinion. The spindle is 1 15/16 in. in diameter above the sleeve and is equipped with a ball thrust bearing. The spindle speeds range from 19 to 350 r. p. m. Through a feed gear box mounted on the head 6 speeds are obtainable. A direct read-

ing depth gage is provided, arranged to throw the speed out. A safety feed throw-out is also arranged at the end of the spindle travel.

The speed box is fully enclosed and the gear runs in heavy oil. A tool tray is mounted on top of the box. A speed plate is furnished giving the operator all spindle speeds at the various positions of the lever. The lever at the bottom of the stump, standing in a vertical position, controls the friction clutches on the pulley shaft in the speed box. This lever, which is convenient for the operator, in neutral position stops every gear on the machine and in connection with the double back lever on the head, the operator can secure six spindle speeds instantly. With the speed box 18 spindle speeds are available and on the cone pulley drive there are 15 spindle speeds. The double back gear is mounted on the back of the head and is fully enclosed.

All gears are of steel except the spindle gear, which is semi-steel. The back gear clutches and clash gears are made of nickel steel heat treated and hardened. The tapping attachment miter gears are enclosed in an oil-tight case and run in oil. The frictions are of the expanding ring type capable of pulling the maximum capacity of the drill and controlled from the front of the machine. The friction rings are adjustable. The bearings throughout the head are of bronze with felt wipers and a recess around the bearing to act as an oil reservoir.

The machine is regularly furnished with a tight and loose pulley for belt drive, but can also be arranged for drive by cone pulleys and a constant speed motor in connection with a speed box, or for variable speed motor drive.

AIR DRILL FOR LIGHT WORK

The Ingersoll-Rand Company, New York, has recently developed a new light weight high power pneumatic non-reversible drill, especially adapted to drilling holes up to 9/16 in. in diameter and reaming holes up to 5/16 in. in diameter. This new drill has been designated as No. 5 "Little David." It weighs 15 lb. and has a free spindle speed of 1,000 r.p.m. With a drill chuck its over-all length

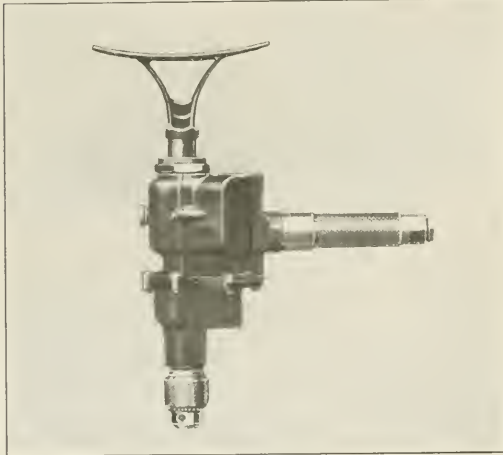

"Little Giant" Air Drill for Light Work

is 14 $\frac{5}{8}$ in. and the distance from the side of the drill to center of spindle is but 1 $\frac{1}{2}$ in., which facilitates its operation in unhandy places. The spindle is threaded to accommodate either a No. 1 M.T. socket or drill chuck and these may be readily interchanged as desired.

The four-piston motor is simple in construction and the accessibility of the reciprocating parts is of particular advantage. The removal of five cap screws permits the crank shaft assembly to be withdrawn in its entirety. The valve is of the rotary type and is gear driven. Roller bearings are used on the connecting rods and ball bearings on the crankshaft. This drill can be furnished with either a breast plate spade handle or a telescoping feed screw. In the latter case the length of feed measures 2 $\frac{1}{2}$ in.

A NEW MILLING MACHINE VISE

Milling machine vises can be used in many cases instead of jigs or fixtures and become an efficient addition to the machines, especially when used in pairs. In this way one vise can be loaded or unloaded while the cutters are still working on a job in the other vise. The Cleveland Milling Machine Company, Cleveland, Ohio, has made interchangeable vises, one of which is shown in the illustration, with the tongue slot an exact distance from the face of the solid jaw.

The steel jaws of the vise are as low as is consistent with

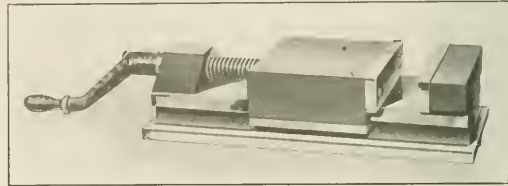

Vise for Milling Machine

strength and may be replaced by special jaws for increasing the range or holding work of irregular shape. Tongue slots are at right angles to each other, so the vise can be held parallel, or at right angles to the spindle, and the screw diameter is made as large as the height of the jaws will allow.

The solid jaw of this vise is made with a special arrangement of cores to prevent it from breaking diagonally from the corner of the solid jaw to the base, due to unequal contraction of the iron in cooling.

DAVIS EXPANSION BORING TOOL

The important part played by boring machines in present railroad shop practice is well known and has resulted in a big demand for boring tools, which are suited to many different kinds of work. The production of turret lathes, boring mills and drill presses will be increased by the use of ex-



Style E Expansion Tool for Turret Lathes

pansion boring tools which are accurate and will stand up under the work. The Davis Boring Tool Company, St. Louis, Mo., has devoted 13 years to the manufacture of this type of tool. The one shown in the illustration is made for turret lathes. The important feature of this tool is the micrometer adjustment for controlling the cutter expansion. This device permits the accurate maintenance of any size within range of expansion, and by compensating for wear, fast feeds and speeds may be used. The pilot is hardened and ground and has oil grooves.

Railway Mechanical Engineer

(Formerly the RAILWAY AGE GAZETTE, MECHANICAL EDITION
with which the AMERICAN ENGINEER was incorporated)

PUBLISHED ON THE FIRST THURSDAY OF EVERY MONTH BY THE
SIMMONS BOARDMAN PUBLISHING COMPANY

EDWARD A. SIMMONS, *President* L. B. SHERMAN, *Vice-President*
HENRY LEE, *Vice-President and Treasurer* M. H. WIUM, *Secretary*
WOOLWORTH BUILDING, NEW YORK, N. Y.
F. H. THOMPSON, *Business Manager*, CHICAGO.

Chicago: Transportation Bldg. Cleveland: Citizens' Bldg.
Washington: Home Life Bldg.
London: Queen Anne's Chambers, Westminster.

ROY V. WRIGHT, *Editor*

R. E. THAYER, *Managing Editor* A. F. STUEBING, *Associate Editor*
C. B. PECK, *Associate Editor* E. L. WOODWARD, *Associate Editor*

Entered at the Post Office at New York, N. Y., as mail matter of the second class.

Subscriptions, including the eight daily editions of the *Railway Age* published in June in connection with the annual conventions of the Master Car Builders' and American Railway Master Mechanics' Associations, payable in advance and postage free: United States, Canada and Mexico, \$2.00 a year; Foreign Countries (excepting daily editions), \$3.00 a year; Single Copy, 20 cents.

WE GUARANTEE, that of this issue 8,700 copies were printed; that of these 8,700 copies 7,380 were mailed to regular paid subscribers, 107 were provided for counter and news companies' sales, 324 were mailed to advertisers, 221 were mailed to exchanges and correspondents, and 668 were provided for new subscriptions, samples, copies lost in the mail and office use; that the total copies printed this year to date were 8,700, an average of 8,700 copies a month.

THE RAILWAY MECHANICAL ENGINEER is a member of the Associated Business Papers (A. B. P.) and the Audit Bureau of Circulations (A. B. C.).

Following the severe winter weather of last month, the Pennsylvania Railroad sent from its shops at Altoona, to different division points on the road, about 300 men, to repair locomotives.

Thirty locomotives built at the Baldwin Locomotive Works, Philadelphia, for military railroads in France have been ordered by the Government to be put in use on the Philadelphia & Reading, the Pennsylvania, the Baltimore & Ohio, and the Lehigh Valley.

The Atchison, Topeka & Santa Fe, which recently announced that it had granted a 10 per cent bonus for the six months' period just ended to unorganized employees, will pay the bonus in regular monthly installments in the coming year with the regular salaries of the men.

The Chicago, Burlington & Quincy has granted an increase in pay to employees in its car department, effective since December 1. Those paid on a straight hourly basis were granted an advance of 2 cents an hour and men on piece work were given a 5 per cent increase.

The War Department announces that volunteers are now being accepted for a provisional reinforcement railway regiment, for the National army, which is being organized at Camp Grant, Rockford, Ill. Men are wanted who have qualifications in railway construction, operation and maintenance; shop work and transportation. Applications are received at all of the principal recruiting stations.

The car repair shed of the Baltimore & Ohio at Storrs Station, Cincinnati, Ohio, was destroyed by fire on November 27, together with 21 freight cars, eight of them loaded. The structure was of frame construction, 48 ft. by 445 ft., open on the sides and with three tracks running the length of the shed. The fire was discovered in the vicinity of the lockers where the men kept their tools and working clothes. Estimated loss on structure, cars, tools and supplies, \$37,000.

The Pennsylvania Railroad has completed arrangements for placing on sale the new war savings stamps and thrift stamps at ticket offices and in its shops, freight stations and in the various departments on the Lines East and West of Pittsburgh. Every ticket agent on the entire system, except those in the immediate vicinity of a post office, will have the stamps for sale. As in the case of the campaign for the two Liberty Loans, special efforts will be made to encourage investment in the savings and thrift stamps on the part of

employees. It having been found impracticable to place the stamps on sale directly in the pay cars, arrangements will be made wherever possible to have them on sale near the pay cars when employees are being paid.

The President has approved the recommendation of the War Industries Board that the maximum prices heretofore fixed by the President upon ore, coke, pig iron, steel and steel products, subject to revision on January 1, 1918, be continued in effect until March 31, 1918. New contracts calling for delivery on or after April 1, 1918, must be subject to revision by any authorized United States Government agency, so that deliveries after that date shall not exceed the maximum price then in force, although ordered or contracted for in the meantime.

The western lines, at the request of the Railroads' War Board, agreed to furnish 102 locomotives to the eastern roads. On December 21, 39 had been delivered at Chicago and seven at St. Louis, while 26 were en route at that time and 30 had not yet started for their destination. It was expected that all the engines would be delivered by December 25, except a few which were being transformed from coal to oil burners. The following pro rata plan for providing the locomotives was decided upon at a meeting in Chicago: Atchison, Topeka & Santa Fe, nine; Northwestern, seven; Burlington, seven; Great Western, one; Chicago, Milwaukee & St. Paul, eight; Rock Island, six; Chicago, St. Paul, Minneapolis & Omaha, two; Duluth & Iron Range, ten; Duluth, Missabe & Northern, twelve; Great Northern, five; Illinois Central, six; Kansas City Southern, one; Minneapolis & St. Louis, one; Minneapolis, St. Paul & Sault Ste. Marie, two; Missouri, Kansas & Texas, two; Missouri Pacific, four; Northern Pacific, five; St. Louis-San Francisco, three; Cotton Belt, one; Southern Pacific, six; Union Pacific, four.

Tank Car Tests and Safety Appliances

The executive committee of the Master Car Builders' Association has issued a circular regarding the hydrostatic tests of tanks of tank cars, stating: "That part of section 23 of the standard specifications for tank cars, classes I, II, III and IV, which requires that the tanks be retested hydraulically at stated intervals, is hereby suspended as to tanks for which such tests shall become due prior to January 1, 1920, except when the cars are shopped for repairs. The

requirements of section 23 of each of the specifications named, that new tanks shall be tested before being put into service, and that tanks damaged to the extent of requiring patching or renewal of one or more sheets, or extensive riveting or recalking of seams, shall be retested before being returned to service, are not suspended."

A circular was also issued regarding safety appliances, stating: "The date effective of rule 3, paragraph (m) of the rules of interchange, regarding the interchange of cars not equipped with United States safety appliances or United States safety appliances, standard, is hereby extended from January 1, 1918, to March 1, 1918.

Headlight Order Modified

In view of the pressure upon the railroads for cars and engines to move war materials, the Interstate Commerce Commission has postponed the effective date of its order requiring locomotives to be equipped with high power headlights from January 1 to July 1 as to all new locomotives placed in service. For locomotives in service prior to that date the changes required are to be made the first time locomotives are shopped for general or heavy repairs after July 1, 1918, and all locomotives must be so equipped before July 1, 1920.

Grand Trunk Safety Bulletin

The safety engineer of the Grand Trunk, in his December bulletin (No. 15), illustrates one of his chief points by a picture of a barrel tipping over the brink of Niagara Falls. In this connection he says:

"Would you go over Niagara Falls in a barrel? *I should say not.* That's a funny question to put into a safety bulletin. What are you driving at anyway? *Just this:* Scores of you men every day are taking chances that are just as unnecessary, just as foolish and just about as risky as going over Niagara Falls in a barrel, and if you could read the reports in my office showing how Grand Trunk men get injured and killed, you would agree with me."

The safety engineer finds that three causes alone are responsible for more deaths to Grand Trunk men than all other causes combined: (1) Run over by cars or engines; (2) Falling from cars or engines; (3) Train or yard men working on cars which are moved by another engine working on the same track.

Railway Regiments' Tobacco Fund

Interest in the Railway Regiments' Tobacco Fund has extended to several associations during the past month, the Railway Business Association announcing that it will donate \$1,000 to the fund from the proceeds of its annual dinner. On the motion of Daniel A. Brady, the New York Railroad Club voted to give \$250 to the fund, \$250 to the Y. M. C. A., \$250 to the Red Cross and \$250 to the Knights of Columbus. The Machinery Club of New York City at a recent board meeting approved a resolution that appropriated one-third of the profits of the cigar department for the month of

December for soldiers' smokes, one-half of this amount to be sent to the New York Sun Tobacco Fund and the other half to the Railway Regiments' Tobacco Fund. A contribution of \$17 was also received from the Signal Appliance Association.

Since the last report in the December number of the *Railway Mechanical Engineer*, contributions have been received from the following supply companies:

American Car & Foundry Company, New York (contribution).....	\$50
Robert H. Backall, Pittsburgh, Pa.....	10 a month for 12 months
J. Alexander Brown, New York.....	10 a month
Bridgport Machine Tool Co., Rochester, N. Y.....	10 a month for 12 months
Corning Glass Works, Corning, N. Y. (contribution).....	120
Damascus Brake Beam Company, Cleveland, Ohio (contribution).....	25
Dayton Malleable Iron Company, Dayton, Ohio.....	10 a month
Dayton Malleable Iron Works, Dayton, Ind.....	10 a month
Railroad Water & Coal Handling Company, Chicago.....	5 a month for 12 months
Rodger Ballast Car Company, Chicago.....	10 a month
Standard Safety Nut Corporation, New York.....	25 to cover six months

It is expected that the second shipment of tobacco will go forward about January 15.

MEETINGS AND CONVENTIONS

No June Mechanical Conventions.—At the meeting of the executive committees of the Master Car Builders and the American Railway Master Mechanics' Associations in New York December 20, it was decided in view of the present state of affairs to hold no convention in June, 1918. If conditions warrant, however, a business meeting may be held in Chicago sometime during the year.

The following list gives names of secretaries, dates of next or regular meetings and places of meeting of mechanical associations:

AIR BRAKE ASSOCIATION.—F. M. Nellis, Room 3014, 165 Broadway, New York City.
AMERICAN RAILWAY MASTER TINNERS', COPPERSMITHS' AND PIPEFITTERS' ASSOCIATION.—O. E. Schlink, 485 W. Fifth St., Peru, Ind. Convention postponed.
AMERICAN RAILWAY MASTER MECHANICS' ASSOCIATION.—J. W. Taylor, Karpen Bldg., Chicago. Convention postponed.
AMERICAN RAILWAY TOOL FOREMEN'S ASSOCIATION.—R. D. Fletcher, Bell Railway, Chicago. Convention postponed.
AMERICAN SOCIETY FOR TESTING MATERIALS.—Prof. E. Marburg, University of Pennsylvania, Philadelphia, Pa.
AMERICAN SOCIETY OF MECHANICAL ENGINEERS.—Calvin W. Rice, 29 W. Thirty-ninth St., New York.
ASSOCIATION OF RAILWAY ELECTRICAL ENGINEERS.—Joseph A. Andreucetti, C. & N. W., Room 411, C. & N. W. Station, Chicago.
CAR FOREMEN'S ASSOCIATION OF CHICAGO.—Aaron Kline, 841 Lawlor Ave., Chicago. Second Monday in month, except June, July and August, Hotel Morrison, Chicago.
CHIEF INTERCHANGE CAR INSPECTORS' AND CAR FOREMEN'S ASSOCIATION.—W. R. McMunn, New York Central, Albany, N. Y. Convention postponed.
INTERNATIONAL RAILROAD MASTER BLACKSMITHS' ASSOCIATION.—A. L. Woodworth, C. H. & D., Lima, Ohio. Convention postponed.
INTERNATIONAL RAILWAY FUEL ASSOCIATION.—J. G. Crawford, 547 W. Jackson Blvd., Chicago.
INTERNATIONAL RAILWAY GENERAL FOREMEN'S ASSOCIATION.—William Hall, 1126 W. Broadway, Winona, Minn. Convention postponed.
MASTER BOILERMAKERS' ASSOCIATION.—Harry D. Vought, 95 Liberty St., New York. Convention postponed.
MASTER CAR BUILDERS' ASSOCIATION.—J. W. Taylor, Karpen Bldg., Chicago. Convention postponed.
MASTER CAR AND LOCOMOTIVE PAINTERS' ASSOCIATION OF U. S. AND CANADA.—A. P. Dane, B. & M., Reading, Mass. Convention postponed.
NIAGARA FRONTIER RAILWAY MEN'S ASSOCIATION.—E. N. Frankenberg, 623 Brisbane Bldg., Buffalo, N. Y. Meetings, third Wednesday in month, New York Telephone Bldg., Buffalo, N. Y.
RAILWAY STOREKEEPERS' ASSOCIATION.—J. P. Murphy, Box C, Collinwood, Ohio. Convention postponed.
TRAVELING ENGINEERS' ASSOCIATION.—W. O. Thompson, N. Y. C. R. R., Cleveland, Ohio. Next meeting, September 10, 1918, Chicago.

RAILROAD CLUB MEETINGS

Club	Next Meeting	Title of Paper	Author	Secretary	Address
Canadian	Jan. 8, 1918	Methods of Conserving Fuel.....	T. Britt	James Powell ...	P. O. Box 7, St. Lambert, Que.
Central	Jan. 10 1918	What Constitutes the Equipment Department and Advantages Offered Young Men for Advancement; Annual Meeting, Election of Officers, Etc.....	F. W. Brazier.....	Harry D. Vought, H. Boutet	95 Liberty St., New York, 101 Carew Bldg., Cincinnati, Ohio, 683 Atlantic Ave., Boston, Mass.
Cincinnati	Feb. 12, 1918	Internal Strains on Steel Rails.....	James Howard	W. E. Cade, Jr.....	
New England	Jan. 8, 1918	Activities of the National Association of Corporation Schools	F. C. Henderschott.....	Harry D. Vought, J. B. Anderson.....	95 Liberty St., New York, 207 Penn. Station, Pittsburgh, Pa., Union Station, St. Louis, Mo.
New York	Jan. 18, 1918	Organization Maintenance	A. R. Ayers.....	Joseph W. Taylor.....	1112 Karpen Building, Chicago.
Pittsburgh	Jan. 25, 1918				
St. Louis	Jan. 11, 1918				
Western	Jan. 21, 1918				

PERSONAL MENTION

GENERAL

R. C. BEAVER has been appointed assistant mechanical engineer of the Bessemer & Lake Erie, with office at Greenville, Pa.

JOHN BENZIES, road foreman of equipment of the Chicago, Rock Island & Pacific, at Trenton, Mo., has been appointed supervisor of fuel economy of the Chicago Terminal, Illinois, and Missouri divisions, with headquarters at Rock Island, Ill.

W. H. BOOTH, road foreman of equipment of the Chicago, Rock Island & Pacific, at El Dorado, Ark., has been appointed supervisor of fuel of the Louisiana, Arkansas and Indian Territory divisions, with headquarters at Little Rock, Ark.

H. CLEWER, master mechanic of the Chicago, Rock Island & Pacific at Trenton, Mo., has been appointed superintendent of fuel economy, with headquarters at Chicago. His duties in this position include the supervision of the use of fuel, locomotive supplies, lubricating materials and general features in connection with the efficiency of locomotive operation.

F. CONNOLLY, road foreman of equipment of the Chicago, Rock Island & Pacific at Herington, Kan., has been appointed supervisor of fuel economy of the St. Louis, the Kansas City Terminal, the Kansas and the El Paso divisions, with headquarters at Herington, Kan.

J. L. CURRY, road foreman of equipment of the Chicago, Rock Island & Pacific, at El Reno, Okla., has been appointed supervisor of fuel economy on the Oklahoma and Pan Handle divisions of the Chicago, Rock Island & Pacific, and also of the Southern and Amarillo divisions of the Chicago, Rock Island & Gulf, with headquarters at El Reno, Okla.

J. H. EDWARDS, electrical foreman of the Chicago, Rock Island & Pacific, has been appointed supervisor of stationary plants, with headquarters at Chicago, with supervision over stationary plants and pumping stations.

J. R. JACKSON, assistant engineer of tests of the Atchison, Topeka & Santa Fe, Chicago, has received a commission as captain in the ordnance department of the United States Army.

C. F. LUDINGTON, superintendent of the fuel department of the Missouri, Kansas & Texas, has been appointed fuel supervisor of the Chicago, Milwaukee & St. Paul, with office in Chicago.

F. MEREDITH, road foreman of equipment of the Chicago, Rock Island & Pacific, at Silvis, Ill., has been appointed supervisor of fuel economy of the Iowa, Nebraska and Colorado divisions, with headquarters at Fairbury, Neb.

EDWARD S. PEARCE, whose appointment as mechanical engineer of the Cleveland, Cincinnati, Chicago & St. Louis, with office at Beech Grove, Ind., was announced in the December *Railway Mechanical Engineer*, graduated from the mechanical engineering course at Purdue University and was first employed in the maintenance of way and mechanical departments of the Norfolk & Western. From June, 1913, to January, 1914, he was employed in the machinery department of Joseph T. Ryerson & Sons, Chicago. On the latter date he entered the service of the New York Central Lines West as a special engineer in the office of the chief mechanical engineer at Chicago, where he re-

mained until June, 1914, when he was transferred in the same capacity to the office of the superintendent of motive power of the Cleveland, Cincinnati, Chicago & St. Louis. In April, 1916, he was promoted to assistant mechanical engineer and in January, 1917, he was again promoted to special engineer in the office of the general superintendent of the transportation department, which position he held until December 1, when his appointment as mechanical engineer became effective.

C. C. RICHARDSON has been appointed assistant to the superintendent of motive power of the Bessemer & Lake Erie, having supervision of the office, accounting and stores departments. His office is at Greenville, Pa.

H. R. WARNOCK, superintendent of motive power of the Western Maryland at Hagerstown, Md., has been appointed general superintendent of motive power of the Chicago, Mil-



H. R. Warnock

waukee & St. Paul, with headquarters at Chicago, succeeding A. E. Manchester, deceased. Mr. Warnock was born at Newcastle, Pa., on July 16, 1870. He began railway work as a freight brakeman with the Pennsylvania Lines West of Pittsburgh in June, 1889, and later in the same year went to the Pittsburgh & Lake Erie as a brakeman. In September, 1891, he was promoted to locomotive fireman and later was locomotive engineer, which position he

held until May, 1900. From that date until July, 1904, he served consecutively as engine dispatcher, roundhouse foreman, and general foreman, resigning on the latter date to become master mechanic of the West Side Belt, Pittsburgh, Pa., where he remained until October, 1905, when he became master mechanic of the Monongahela Railroad. He remained in this position until September, 1913, when he was appointed superintendent of motive power of the Western Maryland, which position he held until his appointment as noted above, which became effective on December 15.

W. E. RICKETSON, mechanical engineer of the Cleveland, Cincinnati, Chicago & St. Louis, with headquarters at Beech Grove, Ind., has been appointed chief of the equipment divisions, valuation department of the New York Central Lines, with headquarters at New York, taking the place made vacant by the death of Mr. Buchanan last February. Mr. Ricketson was graduated from Cornell University in 1907, with degree of M. E. and began railway work in 1903 with the Delaware & Hudson Company, for which company he worked during his summer vacations while attending college. From 1907 to 1910 he was special apprentice with the Lake Shore & Michigan Southern, and the following two years successively was roundhouse foreman of the Lake Erie, Alliance & Wheeling at Alliance, Ohio, and the Lake Shore & Michigan Southern at Ashtabula. He was then general foreman of the latter road at Youngstown, Ohio, until September, 1913, when he was appointed assistant mechanical engineer of the Cleveland, Cincinnati, Chicago & St. Louis. On March 1, 1914, he was promoted to mechanical engineer, which position he held until his recent appointment as chief of the equipment division, valuation department, of the New York Central Lines, as above noted.

P. SMITH, assistant engineer of fuel economy of the Chicago, Rock Island & Pacific, has been appointed supervisor of fuel economy on the Cedar Rapids, Minnesota, Dakota and Des Moines divisions, with headquarters at Cedar Rapids, Iowa.

C. L. TUTTLE has been appointed mechanical engineer of the Bessemer & Lake Erie, with headquarters at Greenville, Pa.

H. D. WEBSTER, mechanical engineer of the Bessemer & Lake Erie, has been appointed engineer of motive power, with headquarters at Greenville, Pa. The organization of the maintenance of equipment department of the Bessemer & Lake Erie was subdivided on January 1, the locomotive department being under the direct supervision of Mr. Webster.

G. F. WIESECKEL, master mechanic of the Western Maryland, with office at Hagerstown, Md., has been appointed superintendent of motive power, with headquarters at Hagerstown, succeeding H. R. Warnock, resigned to go to another company.

F. W. WILSON, engineer of fuel economy of the Chicago, Rock Island & Pacific, has been appointed chief fuel inspector, reporting to the fuel agent.

MASTER MECHANICS AND ROAD FOREMEN OF ENGINES

THOMAS ALLISON has been appointed road foreman of engines on the Pasco division, of the Northern Pacific, with headquarters at Pasco, Wash., succeeding C. A. Wirth, promoted.

J. K. BOOTH, general foreman of the Bessemer & Lake Erie, with office at Greenville, Pa., has been appointed master mechanic, with supervision over the locomotive department shops at Greenville.

ALBERT J. DAVIS, assistant to the master mechanic of the Erie at Hornell, N. Y., has been appointed master mechanic of the Allegheny and Bradford divisions, with headquarters at Hornell.

L. E. DIX, master mechanic of the Trans-Mississippi terminal, a subsidiary of the Texas & Pacific, has had his jurisdiction extended over the Louisiana division of the Texas & Pacific, from New Orleans, La., to Boyce, with headquarters at Gouldboro, La. J. A. Delaney, whose transfer to Big Springs, Tex., was mentioned in these columns last month, was master mechanic of this division.

W. J. EDDY, superintendent of fuel economy of the Chicago, Rock Island & Pacific, with headquarters at Chicago, has been appointed master mechanic at El Dorado, Ark.

HARRY J. FREUND has been appointed traveling fireman of the Central Railroad of New Jersey.

TIMOTHY F. GORMAN, formerly general foreman of the Erie at Brier Hill, Youngstown, Ohio, has been appointed master mechanic of the Meadville division, with office at Meadville, Pa.

W. D. HITCHCOCK has been appointed master mechanic of the Albuquerque division of the Atchison, Topeka & Santa Fe, with headquarters at Winslow, Ariz., succeeding M. Weber, transferred.

J. S. MOTHERWELL, master mechanic of the Louisiana & North West, with office at Homer, La., has been appointed master mechanic of the Oklahoma, New Mexico & Pacific, with office at Ardmore, Okla.

R. H. NICHOLAS, general foreman of the Central of New Jersey at Communipaw (N. J.) engine terminal, has been appointed assistant master mechanic.

CHARLES T. SUGARS has been appointed master mechanic of the Louisiana & North West, with office at Homer, La., succeeding J. S. Motherwell, resigned.

JOHN R. TUNISON has been appointed traveling fireman of the Central Railroad of New Jersey.

J. H. WESTON has been appointed road foreman of engines on the Minnesota division of the Northern Pacific, with headquarters at Staples, Minn., succeeding M. S. Montgomery, resigned.

SHOP AND ENGINEHOUSE

THOMAS J. COLE, master mechanic of the Erie at Meadville, Pa., has been appointed shop superintendent at Meadville.

J. S. HARDWICK, boiler foreman of the Gulf, Colorado & Santa Fe at Galveston, Tex., resigned that position to become a boilermaker at the United States navy yard at Norfolk, Va., and was promoted soon after to chief planner of the boiler construction progress department.

W. E. HARDY, foreman of the Central Railroad of New Jersey, at East Twenty-second street, Bayonne, N. J., has been promoted to general foreman of the engine terminal at Communipaw, N. J., succeeding R. H. Nicholas.

LEE R. LAIZURE, master mechanic of the Erie at Hornell, N. Y., has been appointed shop superintendent at Hornell.

CAR DEPARTMENT

J. B. CONERLY has been appointed master car builder of the Missouri, Kansas & Texas with office at Denison, Tex.

R. D. WILSON has been appointed assistant chief car inspector of the Central Railroad of New Jersey, with office at Jersey City, N. J.

PAUL S. WINTER has been appointed general car foreman of the Bessemer & Lake Erie, with supervision over the car department shops at Greenville, Pa. Mr. Winter was born on April 15, 1884, at Denver, Colo. He attended a manual training school in Denver and secured his first railroad position on June 6, 1901, with the Denver & Rio Grande. He entered the service of the Bessemer & Lake Erie in June, 1903, as a machinist, was transferred to the drafting room in February, 1908, and to the car department in July, 1913.

PURCHASING AND STOREKEEPING

F. W. TAYLOR has been appointed purchasing agent of the Southern Pacific, with headquarters at San Francisco, Cal., to succeed I. O. Rhoades, retired. Mr. Taylor was born at Campo Bello, New Brunswick, on August 5, 1867. He entered the service of the Union Pacific in December 1885, as clerk in the store department at Laramie, Wyo., where he remained until July, 1889, when he was transferred in the same capacity to Pocatello, Idaho, with the division storekeeper of the Union Pacific, the Oregon Short Line and the Southern Pacific lines east of Sparks, Nev., remaining until January, 1911, when he was appointed general purchasing agent of the Pacific Electric, the Peninsula, Stockholm Electric, the Fresno Traction and the Visalia Electric at Los Angeles, Cal., which position he held until the time of his appointment noted above.

OBITUARY

THOMAS A. AYRES, assistant purchasing agent of the Erie with office at New York, died on December 9, at his home in Ridgewood, N. J., at the age of 38.

JOHN H. ORCHARD, foreman car repairs of the Delaware & Hudson at Carbondale, Pa., died on December 5, 1917. He was 62 years old, and from early boyhood was connected with the car repair shops of the Delaware & Hudson.

SUPPLY TRADE NOTES

H. G. Doran & Co., Chicago, has been appointed agent for the Rivet Cutting Gun Company, Cincinnati, Ohio.

J. H. Sharp has been appointed western representative of the Glazier Manufacturing Company, with headquarters at the McCormick building, Chicago.

A. A. Strom, vice-president of the Pettibone-Mulliken Company and president of the U. S. Ball Bearing Company, died in New York on November 29. Mr. Strom was born in Sweden in 1855. He came to this country at the age of 14 and worked in the foundries of N. S. Bouton & Co. at Chicago. He started a small forge shop in Chicago in 1880 with P. A. Godey, at first working at the forge himself. The business increased rapidly and in 1885 it was incorporated under the name of Strom Manufacturing Company. This business was later incorporated with Pettibone-Mulliken Company, with which Mr.



A. A. Strom

Strom had been associated ever since. At his death he was a director and vice-president of that corporation and also president of the U. S. Ball Bearing Manufacturing Company.

F. S. Wilcoxon, who for the past nine years has been mechanical representative for the Perolin Company, New York, has resigned and has accepted a position with the Perolin



F. S. Wilcoxon

Railway Service Company as special representative. Mr. Wilcoxon commenced his mechanical career with the Pennsylvania Company at Wellsville, Ohio. He has served as locomotive fireman and engineer on the C. C. and S. Ry. (now a part of the Wheeling & Lake Erie), also as locomotive engineer and roundhouse foreman on the Alabama Great Southern Railway at Birmingham, Ala., and with the Toledo, St. Louis & Western Railway as locomotive engineer, road foreman of engines, general foreman and division master mechanic. He assumes his duties as special representative of the Perolin Railway Service Company on January 15.

L. S. Love has resigned as sales manager of the Sherritt & Foster Company, Philadelphia, to become general manager of the Machine Tool Engineering Company, Singer building, New York.

The Greaves-Klusman Tool Company, Cincinnati, Ohio, has purchased the building formerly occupied by the Champion Tool Works and will use it as an erecting plant in addition to its present works.

F. H. Bird, traveling engineer of the American Steel Foundries, Chicago, has received a commission as first lieutenant in the ordnance department of the United States army, and is now stationed at Dayton, Ohio.

Peter Leidenger, western sales manager of the Dayton Manufacturing Company, Dayton, Ohio, died suddenly of pneumonia at the Buckingham Hotel, St. Louis, Mo., on December 28. Mr. Leidenger was born at Ironton, Ohio, in 1862, and had been with the Dayton Manufacturing Company for the past 30 years.

New Glidden Company Formed

One of the most important transactions in the annals of the paint and varnish trade of this country has just been concluded by the outright purchase of the Glidden Varnish Company, of Cleveland, Ohio, and its subsidiary, the Glidden Varnish Company, Ltd., of Toronto, Canada, by a newly formed corporation headed by Adrian D. Joyce, who was until recently director and general manager of sales and distribution of the Sherwin-Williams Company. The new company will be known as the Glidden Company, and is capitalized at \$2,500,000, fully paid in.



A. D. Joyce

Associated with Mr. Joyce are O. A. Hasse, formerly manager of paint and varnish sales for the Sherwin-Williams Company, and R. H. Horsburgh, controller of the same company. They will assume the positions of vice-president and secretary-treasurer, respectively, in the new corporation. All three have resigned their connections with the Sherwin-Williams Company, and it is positively stated that the new company is not in any way connected with other paint and varnish interests.



O. A. Hasse

Members of the Glidden family, including F. A. Glidden, heretofore president of the company, will retire from the new corporation, but the balance of the organization will remain intact and will be enlarged as necessity demands.

The present Glidden plant, occupying nearly 17 acres, is a model in completeness of equipment and modern arrangement. With present extension plans completed the company will be the largest varnish plant in the country.

The Glidden Varnish Company has been in business nearly

50 years. Railroad and steamship companies are among the largest Glidden customers. Many large government contracts will be executed by the new company.

Adrian D. Joyce has been 20 years in the paint and varnish business, mostly with the Sherwin-Williams Company. He was for several years a traveling salesman, later special representative for the Industrial Trade, then sales manager of the Kansas City district and finally assistant sales manager of the company in Cleveland. He was then advanced to general manager of sales and distribution. He has had a broad sales and executive experience, and had charge of all sales and warehouse direction. He has been closely identified with national and international affairs in the paint and varnish trade, and is experienced in manufacturing. He has paid particular attention to raw materials and studied specially the new uses of paint and varnish materials. He was a director of the Sherwin-Williams Company.

O. A. Hasse's entire experience has been in the paint and varnish business. He started in the advertising department, then served as secretary and finally was transferred to sales department in charge of sales, serving consecutively in the following departments: insecticides, insulating varnish, railroad, street railroad and marine finishes, also general manufacturing sales, and then for several years he was manager of paint and varnish sales. He has had experience as a traveling salesman, and is familiar with the sales and manufacturing problems, having had at one time entire charge of the development of railway sales. He has also made a deep study of raw materials.

R. H. Horsburgh was with the Sherwin-Williams Company for 18 years, starting as office boy and working up to controller. In this latter position he was in charge of credits, accounts, taxes and insurance. He was in close touch with the financing of the company, was a credit specialist and has spent his entire career in this industry.

The Union Railway Equipment Company, Chicago, has purchased the exclusive rights to manufacture and sell the Bourell brine valve or retainer formerly handled by the Western Sales Company, Chicago.

J. E. Buckingham, formerly northwestern representative of the Standard Steel Works Company with offices in the Northwest Bank building, Portland, Ore., is now assistant general manager of the Hofius Steel & Equipment Company, Seattle.

The Union Supply Company, Chicago, Ill., has opened a branch office in the Call building, San Francisco, Cal., in charge of A. A. Dawley, western representative. Mr. Dawley was formerly purchasing agent of the Denver & Salt Lake at Denver, Colo.

Oscar F. Ostby, 2736 Grand Central Terminal, New York, has been appointed sales representative for the White American Locomotive Sander Company, Roanoke, Va., for territory from Baltimore north to the Canadian border, and west as far as Pittsburgh and Cleveland.

N. B. Payne has opened an office in the Havenmeyer building, 25 Church street, New York, as an electric crane special-

ist dealing in new and used traveling cranes. Mr. Payne was formerly associated with Manning, Maxwell & Moore, Inc., New York, and has an extensive experience in this kind of work.

J. M. Hopkins, president of the Camel Company of Chicago, became chairman of the board of directors on January 1, and was succeeded as president by P. M. Elliott, formerly vice-president. W. W. Darrow, formerly general manager, is now vice-president, and A. B. Wegener, general manager of sales, has been made secretary.

D. Gleisen has been appointed manager of the industrial bearings division of the Hyatt Roller Bearing Company, Newark, N. J. Mr. Gleisen is a mechanical engineer, a graduate of Stevens Institute, and has been connected with the Hyatt Roller Bearing Company for the past six years. He was formerly assistant manager of the Hyatt Company in charge of the bushings sales.

J. W. White has been appointed manager of the power and railway division of the Detroit office of the Westinghouse Electric & Manufacturing Company. Mr. White was formerly connected with the Pittsburgh office of the company, subsequently becoming associated with the Allis Chalmers Company, and has now returned to the Westinghouse Company, assuming the position above noted.

CATALOGUES

RECLAIMED MACHINERY.—The Prest-O-Lite Company, Inc., Indianapolis, Ind., has issued a pamphlet entitled "Turning Waste Into Profit." It contains 82 illustrations and shows the possibilities of reclaiming broken and worn machinery by the oxy-acetylene process.

GAS FURNACES.—Tate-Jones & Co., Inc., Pittsburgh, Pa., has issued Bulletin No. 160 describing its recuperative gas oven furnaces. A series of exhaustive tests show an important saving in fuel of as high as 50 per cent, due to the recuperative feature. Twenty per cent saving over the old type of furnace is guaranteed, a fact which is of importance with the present high price of fuel.

DU PONT PRODUCTS.—There has just been issued a handy little booklet which contains a list of all the products manufactured by the E. I. du Pont de Nemours and Associated Companies, namely, Du Pont Chemical Works, Du Pont Fabrikoid Company, The Arlington Company, and Harrisons, Inc.

JOURNAL BOXES.—The National Malleable Castings Company, Cleveland, Ohio, has issued circular No. 69 describing the National coiled spring journal box. The two features of this box are a positive coil spring action to close the cover, and steel inserts in the pedestal guides to improve wearing qualities. Circular No. 70 by the same company describes an ingenious and simple train pipe hanger and clamp.

PRESSED STEEL TRUCKS.—The Pressed Steel Truck Company of Pittsburgh, Pa., has recently issued folders describing the Atlas two-wheel and four-wheel trucks. These folders are well illustrated and show in some detail the interesting features of construction and describe the various uses to which these trucks may be put. They are constructed with a one-piece frame, without bolts or rivets. They weigh less than wooden trucks and have greater strength. The axles are supported on flexible hardened steel bearings.

NEW SHOPS

SANTA FE LINES.—The Atchison, Topeka & Santa Fe is building additional repair shops at Ottawa, Kan., at a cost of about \$60,000. Swanson Brothers Contracting Company, Topeka, Kan., has the contract for the work.



R. H. Horsburgh

Railway Mechanical Engineer

Volume 92

February, 1918

No. 2

CONTENTS

EDITORIALS:

Motive Power Efficiency and Boiler Scale.....	73
Increased Supervision Necessary.....	73
Ample Ash Pan Opening.....	74
Improved Locomotive Deliveries.....	74
Railroad Power Plants.....	74
High Capacity Hopper Cars.....	75
New Books.....	75

COMMUNICATIONS:

The Railway Employees' "Bit".....	76
T. W.'s Spy Work Comes to Naught.....	76
*Boiler Design—Combustion.....	76

GENERAL:

N. Y. C. 4-8-2 Type Freight Locomotives.....	77
University of Illinois Coal Tests.....	80
Santa Fe 2-8-2 Type Locomotive.....	83
One Month of Federal Control.....	85
Pennsylvania Electric Locomotive.....	87

CAR DEPARTMENT:

Reinforcing Wooden Furniture Cars.....	91
A 100-Ton Coal Car for the N. & W.....	93
The Tank Car in Interchange.....	97
C. M. & St. P. Fifty-ton Gondolas.....	99
Helical Spring Calculation.....	101
Vacuum Cleaner.....	102

SHOP PRACTICE:

Portable Alligator Shears.....	103
A Handy Swivel "V" Block.....	103
Microscopic Study of Worn Tires.....	104
Welding Tubes in the Firebox.....	110
Terminal Time Saving.....	110
Tests of Oxy-Acetylene Welded Joints in Steel Plates.....	111
Device for Milling Keyways for Eccentric Arms in Crank Pins.....	112
A Shop Story with a Moral.....	112
Grinding Superheater Header.....	113
Reducing the Time to Turn Locomotives.....	114
Glass Shields for Grinding Wheels.....	115
Removing Boiler Tubes with an Air Motor.....	115
Claw Bar Dies.....	116

NEW DEVICES:

New Designs of Boiler Tools.....	117
Portable Vise Stand and Pipe Bender.....	117
Locomotive Front End Spark Arrester.....	118
Method of Applying Outside Steam Pipes.....	119
Night Lights for Pullman Cars.....	119
Goggles with Non-Breakable Lenses.....	120
Ashton Master Pilot Gages.....	120

GENERAL NEWS:

Notes.....	121
Meetings and Conventions.....	122
Personal Mention.....	123
Supply Trade Notes.....	124
Catalogues.....	126

Motive Power Efficiency and Boiler Scale

There are many roads that could increase the service secured from locomotives by taking some measures to prevent the formation of scale in the boilers. It is surprising that more is not done to prevent the formation of scale or to remove scale already formed even in districts where the water carries a great deal of incrusting matter. The condition of the boiler is often the most important of the factors which determine when locomotives must be shopped for heavy repairs. There are but few defects of the machinery which cannot be remedied in the enginehouse, but when the boiler requires extensive repairs it is usually necessary to put the locomotive in the shop.

It is hardly necessary to say that anything that will increase the period during which locomotives can be kept in service is important at this time. Motive power is in great demand and railroad shops report a serious shortage of skilled labor. The prices of boiler sheets and boiler tubes are extremely high. The records of roads that have adopted the practice of fighting boiler scale show that there is a marked reduction in the amount of boiler work required and that the service secured from firebox sheets and tubes is increased. There is another advantage to be gained by such treatments. If the sheets and tubes are clean, they conduct heat much more readily than if the surfaces are covered with scale. At present, when the saving of fuel is of such great importance, the opportunity for conservation by this method should not be overlooked.

It requires but a comparatively slight investment to install an anti-scale forming system. The supervision required to keep it operating satisfactorily is likewise small. The advantages to be gained are great, particularly under

the present circumstances, and roads that are troubled with bad water conditions should give thorough consideration to the results that can be secured by adopting a method of preventing scale.

Increased Supervision Necessary

Regardless of the number of men working in either the shops or engine houses, there is at this time a most decided demand for competent and adequate supervision. The labor turnover has been so great even among the old employees that unless the new men coming into the shops are carefully instructed, the work will not be properly done and a great deal of time will be wasted. In the past the railroads have had plenty of "railroad" mechanics to whom specific jobs could be intrusted with no more than passing supervision and inspection. These men were assigned to particular work and kept constantly on that work, becoming proficient in it. They had been with the railroads for a long time—in most cases they were brought up in railroad shops; but now the industries have taken a large number of these men away. Their places have been filled by the uninitiated—men who are unfamiliar with railroad shop practice. It is these men that must be educated to the peculiarities of railroad repair work. Adequate supervision is the answer. The railroad shops must have it and the railroads must make it worth while for experienced railroad mechanics to stay with them.

The depletion of the forces has not been restricted to the mechanics alone. Many foremen have been tempted away by better conditions and more pay. These men must be taken care of as well as the mechanics. Some roads have

done this admirably and have had little disturbance to their organization. Other roads have lost many able men. The need for locomotives and cars was never greater than it is at the present time. Every means must be taken to keep them in repair. The mechanical department officers should not allow their forces to become disorganized. The living conditions must be met. The only way to hold the men is to make the work attractive to them.

Ample Ash Pan Opening

Club. He told of a case where it was desired to burn high volatile coal in some new stoker locomotives, but that only one engineman was able to do it successfully, the others finding it necessary to use coal having lower volatile matter. This engineman would not give up his secret. By watching him carefully it was found that he opened the ash pan slide, permitting more air to get in under the grate. This circumstance clearly shows how important it is to have proper ash pan opening.

There are many locomotives operating today which are handicapped by this very thing. Not only is the capacity of the locomotive limited, but coal is wasted, the gases passing off through the stack unburned. The best accepted practice requires that the total free air opening in an ash pan be 14 per cent of the grate area. Where these openings are covered by netting, the restrictions caused by the netting must be considered. It is the customary practice to provide these openings at the sides. Investigations are being made, however, to determine whether or not part of the air might be admitted to the ash pan advantageously at the front and back. In any case it is essential that enough air be admitted and that the volume of the ash pan be sufficiently large.

Improved Locomotive Deliveries

In the article on the locomotive orders in 1917 in last month's *Railway Mechanical Engineer* the statement was made as to the locomotive situation that "the outlook both for deliveries and production in 1918 looks exceedingly favorable," and it was further added that "the supply field is confidently expecting a large buying movement." Although less than a month has passed since that time, these prophecies, if such they may be called, are already being borne out. In the month of January, to take new orders first, 197 locomotives were ordered, including 29 for export and 168 for domestic roads,—not a record breaking figure by any means, but a considerable increase over the totals for the months immediately preceding. Nearly all of the domestic orders were for eastern lines and the major part of them were large sized engines. The situation as to deliveries of locomotives now on order is improving from day to day. The American Locomotive Company has on its February schedule about 200 locomotives, nearly all of which are large units. The Richmond and Montreal plants are now being made over for locomotive instead of shell production, which will mean in the near future, a further increase of about 25 or 30 locomotives a month.

The Baldwin Locomotive Works is now approaching a capacity output of 100 large locomotives a week and with new facilities nearing completion and expected improvements in the labor and material situation, should soon reach that figure. The eastern roads will, of course, secure the benefit of the increases in output, Director-General McAdoo having ordered that all locomotives for domestic railroads produced in January, February and March, amounting to 150, 250 and 250 respectively, be turned over to specified eastern roads, regardless of who contracted for them. The swinging

of 165 locomotives now in service from western to eastern roads; the putting in service on the rails here of 100 locomotives intended for the American forces in France; the contemplated conversion of 200 Russian locomotives, and the new deliveries will help the motive power situation tremendously. In short, the motive power officer can now see ahead of him the opportunity to overcome the serious shortage of motive power that is driving all railway men to distraction. The new orders, further, will guarantee that future production will be kept up. It was natural that there should have been few orders for new locomotives in the fall of last year when priority was given to Russian and other orders. Now that every possible step is being taken to increase the production of locomotives for domestic use, and a railway can look forward to receiving its locomotives before the war is over, increased orders for locomotives for domestic roads can confidently be expected. It is fortunate that at last extraordinary efforts are being taken to relieve a very bad condition.

Railroad Power Plants

Railroad power plants consume a large amount of fuel, but as a rule they receive very little notice. The fuel consumption of locomotives is watched closely to insure economy, but the consumption of the power plant is relatively small and for that reason escapes attention. On a number of roads the amount spent for fuel for power plants amounts to half a million dollars a year, and a considerable expenditure for supervision is justified if it will result in a reduction of this large item of expense.

It is surprising to note how many roads have retained at their shops the system of providing separate power plants for each building or department. This inevitably requires the services of a considerable number of men, making the cost of wages excessive. The equipment of such small plants is usually inefficient, radiation losses are high, combustion is poor and the handling of coal and ashes crude and uneconomical. With fuel so expensive and labor so hard to get, such conditions should not be allowed to exist. The investment required to replace small units with a single well-designed and well-equipped plant will yield big returns.

In centralized plants the most serious waste usually results from improper operation rather than from poor design. Engines and generators are ordinarily kept in good condition, but the boilers and their appurtenances, though even more important, are often neglected. In most plants the exhaust from the auxiliaries can be used to heat the feed water. If the water contains considerable amounts of impurities it should be treated. The factors effecting combustion should be given close attention. The draft should be suited for the kind of fuel used and should be strong enough to insure complete combustion. Where economizers are used special attention must be paid to the matter of securing sufficient draft. Boiler settings and stacks should be kept free from leaks.

In the distribution of power constant attention is necessary to prevent waste. A 1/16-in. hole in a steam line carrying 150-lb. pressure will waste 26 lb. of steam an hour, which is nearly a boiler horsepower. A hole of the same size in an air line carrying a pressure of 100 lb. will waste more than a horsepower. In electric circuits there is danger of power being wasted by keeping lights burning when they are not needed and by running shafting when none of the machines it drives is in use. There are countless other things that often result in inefficient operation in power plants, some of the most important being the practice of operating too many boilers at low capacity and failure to give proper attention to the removal of scale and soot from boilers.

Frequent and regular inspection with prompt attention to cleaning and repairs when needed will do a great deal toward

keeping the efficiency of the power plant at a high level, but inspection will not always show up the losses that occur, and for that reason it is advisable to run frequent tests, or better still, keep continuous records to determine whether the maximum economy is being secured from the plant. In a small plant elaborate apparatus is not required. Every power-house should keep a record of the water and coal consumption and the draft on the boilers and should have periodic analyses made of the coal and ash. Larger plants should be equipped with flow meters, temperature recorders and apparatus for making flue gas analysis.

Railroad power plants as a rule are given very little supervision. To operate a power plant successfully requires special training. Very few master mechanics or general foremen have sufficient knowledge of power plants to manage them efficiently. The best way to overcome this difficulty is to have a special organization to supervise the operation of all the power plants on the system. By having a special organization in charge of the power plants it is possible to insure that every plant will have expert supervision. It is by no means easy to secure competent engineers to operate power plants. If the plants are under the jurisdiction of the master mechanic or general foreman, the engineer has few opportunities to secure promotion. Where all the power plants are under one head the matter of advancement can be handled much more satisfactorily. This is one of the important advantages in having a special organization in charge of power plants.

High Capacity Hopper Cars

One feature in the design of the so-called 100-ton coal car, recently built by the Norfolk & Western, not brought out in the description of the car which appears elsewhere in this issue, is the remarkably light weight of the car in relation to the capacity. The cars as shown are nominally rated at 90 tons which provides a maximum carrying capacity with 10 per cent overload of practically 100 tons, and the light weight of the car is 60,000 lb. The ratio of revenue load to the gross weight of the loaded car is 77 per cent, a ratio which, so far as is known, has not successfully been exceeded. This is the more remarkable when it is considered that the cars are carried on six-wheel trucks which hardly weigh less than 15,000 lb. apiece. What this means may be well brought out by a comparison with the similar ratio for the average 50-ton coal car. There are thousands of these cars in service, the light weight of which varies little from 42,000 lb. There are probably more instances in which this weight is exceeded than there are in which the weight is less. With a light weight of 42,000 lb. and allowing for a 10 per cent overload, the ratio of revenue load to the total gross weight of the car is 72 per cent. There are few cases in which this ratio has exceeded or even reached 73 per cent for cars of 50 tons capacity.

The new car is the second of similar capacity which has been designed by the Norfolk & Western, the first having been a 90-ton gondola car for coal service, and of practically the same light weight. A large number of the former type have now been in service for several years and it is evident that there is no inherent difficulty in securing this high proportion of paying load in cars of this capacity. To do so, however, requires a thoroughness and care in the design and construction which few railroads apparently have the foresight to insist on.

The extent to which cars of capacities greater than 50 tons are being built raises the question as to how far this increase in car capacity may be expected to go. The increases in capacity have led to the development of a 6-in. by 11-in. M. C. B. axle and the Pennsylvania Railroad on its 85-ton hopper car, which is carried on four-wheel trucks, is using axles with 6½-in. by 12-in. journals. In

the case of the average 50-ton cars, allowing for a 10 per cent overload, the axle loads with four-wheel trucks are well within the allowable limits for the 5½-in. by 10-in. M. C. B. axle. In fact, a few cars of 55 and 57½ tons rated capacity have been built in which the axle loads have been within or but slightly exceeding the allowable load for this size of axle, which is in the neighborhood of 41,000 lb. at the rail.

The 6-in. by 11-in. axle, which is the largest M. C. B. standard, will provide for cars with four-wheel trucks having a capacity of about 70 tons, the axle load at the rail not exceeding about 53,000 lb. It is questionable whether it is desirable to increase the axle load materially beyond this point when the small arc of contact between the 53-in. wheel and the rail is considered. The use of the six-wheel truck again extends the possibility of increased capacity, but for the standard 6-in. by 11-in. axle, the limit has already been reached in the case of the Virginian 120-ton cars which are designed to have an axle loading of over 52,000 lb.

While few cars of 50 tons capacity have been built having a revenue load ratio exceeding 72 per cent, there are several instances of cars of 55 and 57½ tons capacity in which this ratio has been brought up to 75 per cent. By intensive design there should be possibilities of further increasing this ratio without increasing the size of the car beyond the capacity of four-wheel trucks. There is undoubtedly an advantage in increasing the capacity of coal cars up to the point where maximum loading for a four-wheel truck is reached, aside from the increased paying load ratio which usually follows. This is incident to the reduction in the number of axles and therefore the frictional resistance per ton of train. Beyond this limit, however, when the six-wheel truck is adopted this advantage is immediately lost. It may therefore be questioned just what advantage is obtained by the increase in car capacity beyond a load which may practically be carried on four-wheel trucks. It would seem that a carefully designed 70-ton car, which does not exceed the capacity of four 6-in. by 11-in. axles, offers practically all of the advantages of cars of higher capacity without exceeding a reasonable wheel load and the additional advantage of avoiding the use of six-wheel trucks.

NEW BOOKS

Proceedings of the International Railway Fuel Association. 416 pages, illustrated, 6 in. by 9 in. Published by the association, J. G. Crawford, secretary, 702 East Fifty-first street, Chicago, Ill. Price, leather bound, \$1.50; paper bound, \$1.

This is the official proceedings of the ninth annual convention of the Railway Fuel Association, which was held in Chicago, May 14 to 17, 1917. It contains papers with complete discussions on the following subjects: Powdered Coal; Storage Coal; Locomotive Feedwater Heating; Front Ends, Grates and Ash Pans; Car Shortage and Coal Shortage; Conservation Appeal; Council of National Defense; Fuel Economy in Relation to Reducing the Cost of Kindling Fires in Locomotives; Fuel for Small Furnaces; Graphical Daily Records of Performances of Engines and Locomotives; Soot; Tests of Six Grades of Coal from a Franklin County (Illinois) Mine, and Theory, Practice and Results of Fuel Economy. Of particular interest are the papers and discussion on locomotive feedwater heating and the tests made by the University of Illinois for the association on Illinois coal. Unlike the majority of the organizations of railroad officers, this association did not cancel the annual convention of the past year. Instead it endeavored to make the meeting helpful to the members in handling the new problems caused by the war.

The appeal for conservation of fuel, which was given wide publicity at the time of the convention, deserves more than passing attention.

COMMUNICATIONS

THE RAILWAY EMPLOYEES' "BIT"

KANSAS CITY, MO.

TO THE EDITOR:

So much has been said lately about the efficiency of machinery and methods needed to win the war, that I feel impelled to call attention to the importance of the personal equation and our attitude.

Among the supervisors of departments and shop foremen we find a few who are living in the wrong age. They do not seem to realize that trying to drive men is long since out of date and much better results are obtained by treating an employee like a man and rewarding faithful effort with a generous word, if nothing more. Do you think that the foreman who always wears a frown, reprimands a man in the presence of fellow workers and gives his orders in a domineering, slurring manner, is working for the best interests of his employer and of his country? Certainly not. Such men are impeding our progress and interfering with the successful prosecution of the war.

If the browbeating foreman is hurting our cause, so also is the workman who continually picks the easiest job he can find and then does as little at it as possible.

Since our country entered the war some remarkable achievements have been attained by the great army of railroad workers. So let us continue the good work and cooperate in every way for the solution of our common problem.

All unnecessary work must take second place and attention be concentrated on matters of vital interest. Paint and polish will never carry our grain from the middle west to the boys in France. We must watch our scrap piles and prove the fallacy of that old proverb as to the extravagance and improvidence of American methods. The welding process has made possible the reclamation of many articles. Use it to the fullest extent. Keep the drop pit busy so that locomotives with light mileage will not block the back shop, and above all, let every one of us be awake to his job, and wear a smile if it hurts.

M. C. WHELAN.

T. W.'S SPY WORK COMES TO NAUGHT

(With apologies to Wallace Irwin)

CHICAGO, ILL.

DEAR EDITOR:

Sherman were correct; however, illustrious warrior receive greater acclaim if he had assume job of I. C. C. detector for few month or spend six weeks in easy chair absorbing duty of rr general manager which deal with brotherhood bolshevik. The object of these reflection are the following to wit: For four year, I have collect with elaborate finesse complete data to erect Locomotive Rogue Gallery. This are divided by railroad and state and are across file to select any number if so desire. I have perform this secret service unknown to U. S. government and rr official.

This tickle system show me at glance date when penalty due on flues not remove, jacket remove for examination, flexible staybolt cap ready to come off. It also record worst tire, date of hydro-elastic test also any little defect which afford ground for Form 5 invitation on mm. Whenever I make journey on particular rr, this index are consult for possible offender. I have scheme fix so I can take list of engine due and be ready to issue card on sight if she are working overdue. Old locomotive are choice game on account of safety factor get tighter each year and it are difficult job to change staybolt spaces, thickness of sheet, ancient method of rivets to comply with efficiency of joint.

However this are same as inquest now. Just as elaborate case are complete and victory within grasp, just as game are ready to fall in bag. Big Chief at Washington announce oxygen treatment for patient which is same as calling armistice on Bug river to panting Red Guard of Petrograd. Announcement say flue are good for duration of war, jacket can stay on added period equal to length of war, staybolt caps examination are extend six months, electric headlight capacity to see normal man on normal track in normal weather with normal visage 800 feet away are postpone nine month—other penalty defect are to be dealt on with same lenience. My overtime now do not bring emolument of one half instead of time and a half. I are complete discouragement. Since RR men also work for U.S. gov't, it maybe constitute treason or less majesty at least to issue Form 5 invitation on soldier of U.S.A. formerly common rr master mechanic.

It are of course impossible, however, I yearn to converse a few sentences with honorable general mention in prelude.

Yours truly,

TOBESURA WENO.

BOILER DESIGN—COMBUSTION

NEW YORK.

TO THE EDITOR:

Your article in the January number on the advantages to be derived from the utilization of the university test plants in the investigation of problems of locomotive design calls attention to our limited and hazy knowledge concerning many factors that enter into locomotive design.

A correct determination of the relations between grate area, firebox volume, length of combustion chambers and length and diameter of flues means much—not only from the theoretical standpoint of generation and transfer of heat, but from the practical standpoint of boiler maintenance and repair.

Insofar as the boiler is concerned, the problem is not only to get a design that will give the maximum capacity with high efficiency, but also to get a design that will give maximum service with a minimum amount of attention and repairs. Cracked flue sheets, leaky flues, and flues plugged with cinders and slag are sources of constant trouble; and a large part of locomotive failures and terminal delays are directly traceable to these causes. Anything that will eliminate or reduce these troubles will increase the efficiency of our railroads.

The experience of some railroads owning locomotives equipped with barrel combustion chambers of generous length and flues of moderate length, indicates that such an arrangement is not only conducive to higher boiler capacity and efficiency, but also reduces the troubles mentioned above. It is obvious that what might be termed a "floating" flue sheet (such as used in a barrel combustion chamber) should give less trouble than the comparatively "rigid" flue sheet as used in the ordinary firebox. The use of flexible staybolts and welded seams has eliminated the most objectionable features of the combustion chamber; and the designs at present used permit a freedom of movement that cannot be had with the straight flue sheet rigidly secured to the mud ring.

Moving the flue sheet forward with the installation of a combustion chamber also reduces the temperatures to which it is subject, and reduces the wide variations in temperature which are constantly occurring in the ordinary firebox, and which are the source of most of our flue troubles.

The plugging of flues is due to imperfect firebox conditions—and anything that can be done to increase the thoroughness of combustion will reduce these troubles. Combustion chambers do increase the effectiveness of combustion and reduce the trouble due to flues honeycombing.

Entirely apart from all theoretical considerations, the questions which you have raised point the way to developments that will make the locomotive not only a more efficient machine in service, but one that is more practical and economical from a maintenance standpoint.

J. T. ANTHONY.

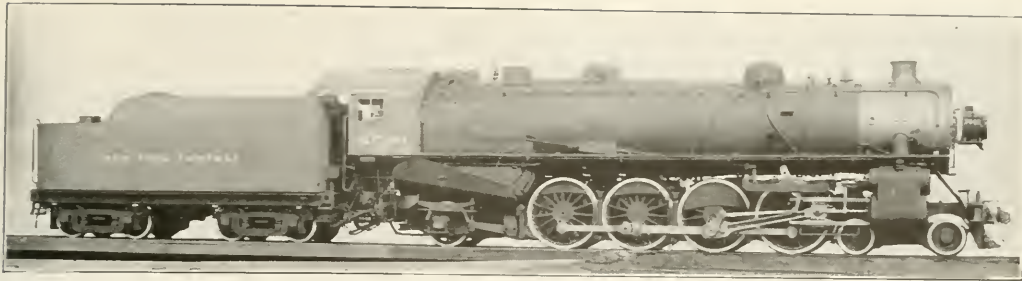

N. Y. C. 4-8-2 TYPE FREIGHT LOCOMOTIVES

Over 2,600 Drawbar Horsepower Has Been Developed; Capacity at High Speeds Is Well Sustained

CONSIDERABLY more than a year ago the New York Central received from the American Locomotive Company its first order of 30 locomotives of the 4-8-2 type, which in several respects are the most notable locomotives of this type yet built. Since that time orders have been placed for more of these locomotives until at present there are nearly two hundred of them either in service or on order.

Heretofore locomotives of this wheel arrangement invariably have been built to handle heavy passenger trains over mountain grades under conditions making difficult the maintenance of schedules with Pacific type locomotives. Locomotives of this wheel arrangement have therefore come to be known as the Mountain type. On the New York Central, however, the 4-8-2 type locomotives have been built for freight service on a line with comparatively few grades, on which, to an unusual extent, car limits determined by operating conditions and facilities other than motive power are the determining factors in the length of trains. The type name generally applied to these locomotives is obviously a misnomer in this case and these locomotives have therefore been styled the "Mohawk" type on the New York Central, after the name of the division upon which they were first placed in service.

It will be noted that the average load per pair of driving wheels in the case of the 4-8-2 engines has been kept well within 60,000 lb., and they have been designed to take curves up to 19 deg. With their well designed reciprocating parts they should cause little difficulty in the maintenance of track.

Tractive efforts developed at the various speeds and the corresponding drawbar horsepowers are exhibited by the drawbar pull-speed chart, plotted from results obtained in dynamometer car tests with a steam pressure of 200 lb. per sq. in. It will be noted that the tractive effort of the locomotive is well sustained at the higher speeds.

On the basis of Cole's ratios, these locomotives should develop a maximum cylinder horsepower of 2,683 at a piston speed of 1,000 ft. per minute. In determining the ratio of boiler capacity to maximum cylinder demand, Cole's ratios are based on a steam consumption of 20.8 lb. per indicated horsepower-hour for superheater engines, and the grate is proportioned to burn four pounds of coal per indicated horsepower-hour at a rate not to exceed 120 lb. per square foot of grate area per hour. On this basis of comparison, the evaporative capacity of the boiler is equal to 98 per cent of the maximum cylinder demand, while the grate area is proportionately slightly smaller.

The boiler is of the conical type with an outside diameter of 81 7/16 in. at the first ring. The engines as originally built carried 185 lb. but the boilers were designed to carry a working pressure of 200 lb. and the pressure has been raised to 190 lb. per square inch since the engines went into service.

It will be seen that instead of the usual type of rod braces at the front and back heads, the heads of the boiler of the

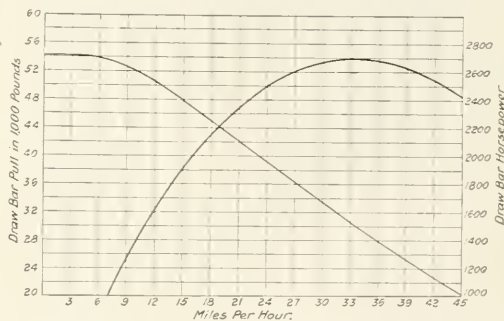

Drawbar Pull and Drawbar Horsepower Characteristics of the New York Central 4-8-2 Type Locomotive with Boiler Pressure at 200 lb. per Sq. In.

"Mohawk" type locomotives are braced with gusset sheets, the ends of which are bolted between angle bars forming the flanges for attachment to the boiler head. Where attached to the roof sheet the back head braces are flanged to conform to the curve of the sheet, while each front gusset sheet is bolted to the radial leg of an angle bar. The other leg of this angle bar forms the flange for securing the brace to the boiler shell.

The longitudinal seam of the dome course is on the top center line. It is of the butt joint type with inside and outside welt strips and the butt joint is welded throughout the length of the seam. The dome is of pressed steel formed in one piece and the flanges are extended in strips 13 1/2 in. and 14 in. wide respectively, in front of and back of the dome, to form the outside welt strip of the barrel seam. The inside welt strip is bifurcated at the dome and forms the reinforcing pad under the dome flange.

There are no unusual features in the firebox construction. It is fitted with a Security brick arch carried on four tubes three inches in diameter and has a barrel combustion chamber

which extends forward into the barrel of the boiler 40⁷/₈ in. beyond the firebox throat sheet. The tubes and flues are 21 ft. 6 in. long, measured over the tube sheets. As built, the locomotives are hand-fired through two firedoor openings which are closed with air-operated firedoors.

The front end arrangement includes a 6³/₄-in. exhaust nozzle and a 19-in. stack extension which extends down to a point 33.4 in. above the center line of the smokebox.

The main frames and the single front rails under the cylinders are cast in one piece on each side. The top rail over the pedestals has a section 6 in. wide by 7 in. deep. The lower rails are 4¹/₂ in. deep at the smallest section, increasing to a depth of 5¹/₄ in. over the ends of the pedestal binders. The rear frame and back deck plate are an integral steel casting, the forward ends of which are bolted to the rear ends of the main frames. The radius bar fulcrum, the pockets for the rear ends of the trailer springs and the trailer equalizer bar fulcrums are all an integral part of this casting.

With the exception of those for the main pair of drivers, the driving journals are 11 in. in diameter by 13 in. long.

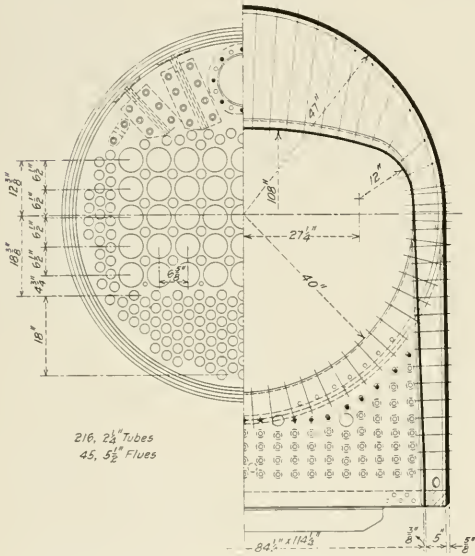

The Tube Sheet Layout and Section Through the Firebox

The journals of the main drivers are 11¹/₂ in. in diameter and 18 in. long. Except for their length, the driving boxes used on this axle are similar in construction to those ordinarily used where the center line of the driving box and the center line of the frame coincide. The main jaws are widened by the use of steel castings which are bolted against the inside face of the pedestals. These castings also perform the function of frame crossies. By the introduction of offset cross equalizers in the spring hanger system at either end of the main driving springs, the position of the main springs has been moved in so that they are located directly over the longitudinal center line of the driving boxes. Each spring rests in a saddle of the usual type designed to clear the offset position of the frame rail relative to the center line of the box.

Steam is admitted to the valve chambers through an outside dome connection type of throttle valve and distributed by 14-in. piston valves having a travel of 7 in. The valves are operated by the Walschaert valve gear, fitted with the Ragonnet power reverse gear.

The engines are fitted with Woodward engine trucks and

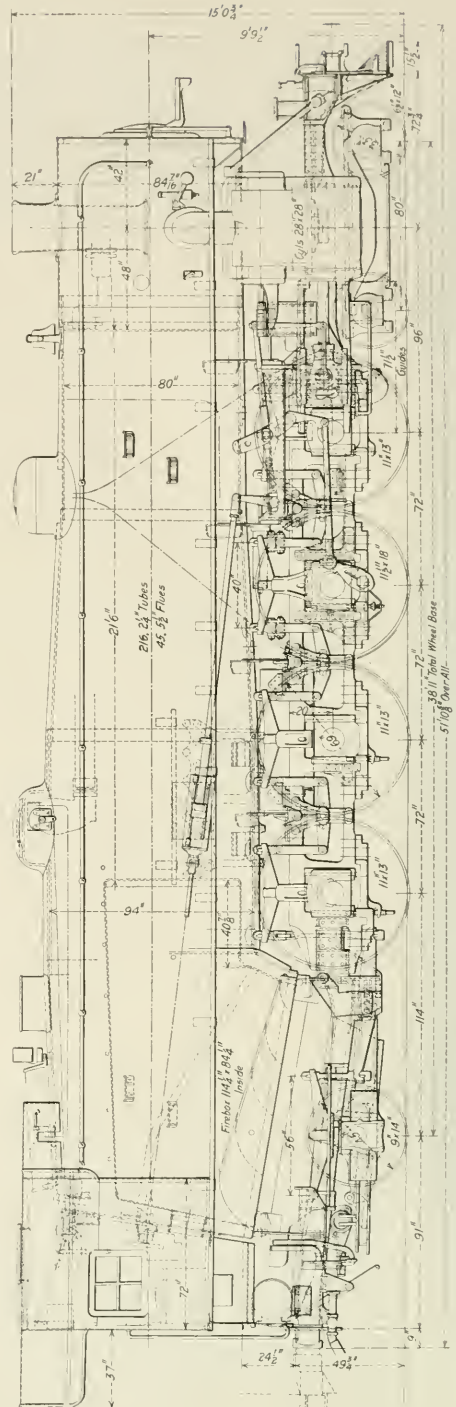

Elevation Showing the General Arrangement of the New York Central 4-8-2 Type Freight Locomotive

Cole radial trailing trucks. The engine truck has a swing of 4 1/4 in. on each side, and the swing of the trailing truck is 5 1/4 in. on each side.

It is evident that the development of the full capacity of a locomotive capable of delivering 2,600 indicated horsepower with a coal consumption of approximately three pounds per horsepower-hour, thus requiring the combustion of about 7,800 lb. of coal per hour, is beyond the possibility of attainment by hand firing. As the locomotives are hand fired, they

Traction effort	31,400 lb.
Weight in working order	343,000 lb.
Weight on drivers	234,000 lb.
Weight on leading truck	52,500 lb.
Weight on trailing truck	56,500 lb.
Weight of engine and tender in working order	509,500 lb.
Wheel base, driving	38 ft. 11 in.
Wheel base, engine and tender	72 ft. 9 in.

<i>Rates</i>	
Weight on drivers ÷ traction effort	4.6
Total weight ÷ traction effort	6.7
Traction effort × diam. drivers ÷ equivalent heating surface	567.6

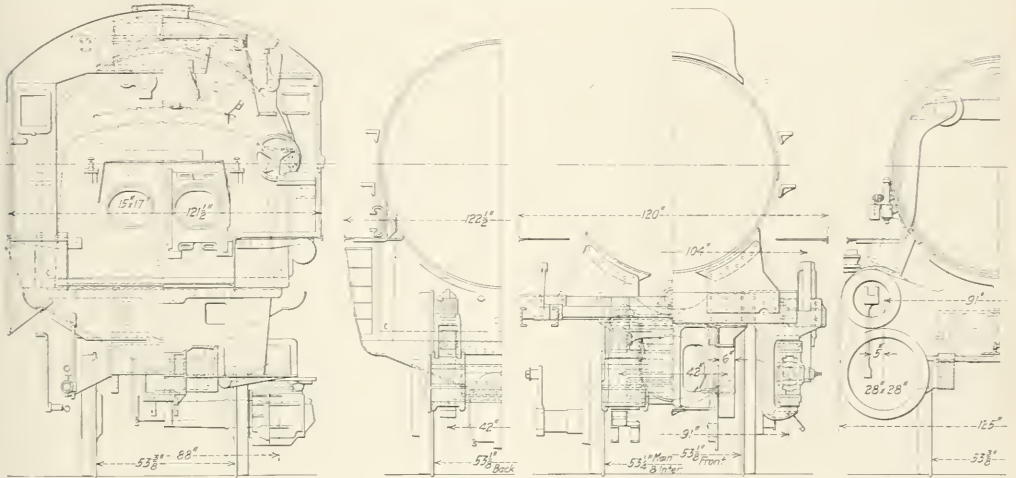

Cross Sections of the New York Central Locomotive

have never developed their full capacity in regular road service. They have been able to decrease the time required to handle tonnage trains over the division, and in fast freight service they handle actual tonnage of from 2,500 to 3,500 tons, in adjusted tonnage trains of 75 to 95 cars, over a division 139 miles long in from five to eight hours' total time on the road. The engines have been built so that stokers may

Equivalent heating surface ÷ grate area	93.5
Firebox heating surface ÷ equivalent heating surface, per cent.	5.1
Weight on drivers ÷ equivalent heating surface	37.5
Total weight ÷ equivalent heating surface	55
Volume both cylinders	20 cu. ft.
Equivalent heating surface ÷ vol. cylinders	312.4
Grate area ÷ vol. cylinders	3.3
<i>Cylinders</i>	
Kind	Simple
Diameter and stroke	28 in. by 28 in.

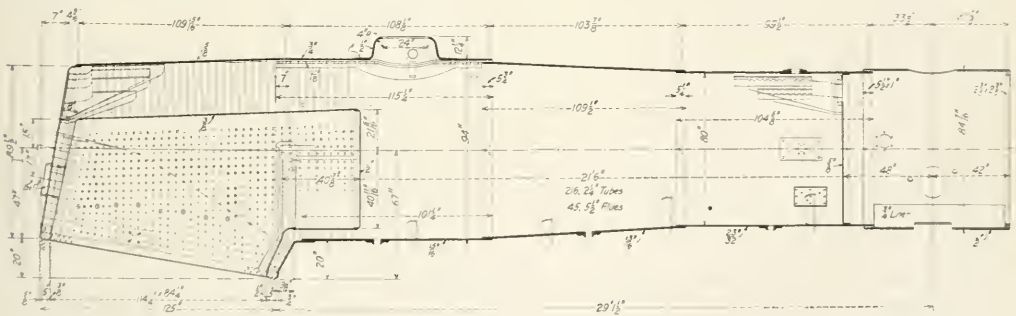

Sectional Elevation of the Boiler

readily be applied whenever traffic conditions require the use of their total horsepower capacity. In the meantime advantage is being taken of the more efficient combustion obtained under the conditions of hand firing.

The principal dimensions and data are given in the following table:

<i>General Data</i>	
Gauge	4 ft. 8 1/2 in.
Service Fuel	Freight Bit coal

<i>Valves</i>	
Kind	Piston
Diameter	14 in.
Greatest travel	7 in.
Outside lap	1 in.
Inside clearance	0 in.
Lead	1/8 in.
<i>Wheels</i>	
Driving diameter over tires	69 in.
Driving thickness of tires	3 1/2 in.
Driving journals, main, diameter and length	1 1/2 in. by 18 in.
Driving journals, others, diameter and length	1 1/2 in. by 13 in.
Engine truck wheels, diameter	33 in.

Engine truck, journals.....	6½ in. by 12 in.
Trailing truck wheels, diameter.....	45 in.
Trailing truck, journals.....	9 in. by 14 in.
<i>Boiler</i>	
Style.....	Coneical
Working pressure.....	190 lb. per sq. in.
Outside diameter of first ring.....	81 7/16 in.
Firebox length and width.....	114½ in. by 84½ in.
Firebox plates, thickness.....	Crown, sides and back, ¾ in.; tube, ½ in.
Firebox, water space.....	5 in.
Tubes, number and outside diameter.....	216—2¼ in.
Flues, number and outside diameter.....	45—5½ in.
Tubes and flues, length.....	21 ft. 6 in.
Heating surface, tubes.....	4,110 sq. ft.

Heating surface, firebox, including arch tubes.....	320 sq. ft.
Heating surface, total.....	4,430 sq. ft.
Superheater heating surface.....	1,212 sq. ft.
Equivalent heating surface.....	6,248 sq. ft.
Grate area.....	668 sq. ft.
<i>Tender</i>	
Tank.....	Water bottom
Frame.....	Cast steel
Wheels, diameter.....	166,500 lb.
Journals, diameter and length.....	36 in.
Water capacity.....	5½ in. by 10 in.
Coal capacity.....	8,000 gal.
	14 tons

* Equivalent heating surface = total evaporative heating surface + 1.5 times the superheating surface.

UNIVERSITY OF ILLINOIS COAL TESTS*

Comparative High and Medium Capacity Performance of Various Grades in Locomotive Service

THE tests, the results of which are here set forth, were made by the Railway Engineering department of the University of Illinois in co-operation with the committee on Fuel Tests of the International Railway Fuel Association and the United States Bureau of Mines. Their general purpose was to determine the relative value in locomotive service of various grades of coal.

For this purpose six sizes of coal chosen by the International Railway Fuel Association committee were tested in the locomotive laboratory, on a Mikado type locomotive loaned by the Baltimore & Ohio. These grades were mine run, 2-in. by 3-in. nut, 3-in. by 6-in. egg, 2-in. lump, 2-in. screenings, and 1¼-in. screenings, all from United Coal Mining Company's Mine No. 1 at Christopher, Franklin County, Illinois.

The general test program involved for each grade of coal six tests, three of which were made at a medium rate of evaporation, and the remaining three at a high rate. The medium rate was chosen to represent an average rate of working the locomotive, in so far as it is possible to define

ity of the analyses and of the heating values make it clear that such differences in performance as developed between the various grades are due chiefly to differences in their mechanical makeup, and only in small measure to differences in their chemical composition.

Due to differences in the nature of the coal, in mining methods, and in methods of preparation, there is frequently much uncertainty about the meaning of such terms as "mine run," "lump," etc. The laboratory has devised a method of screening samples of the coals used during tests for the purpose of separating them into their size elements.

Three carloads each of mine run and lump, and two carloads of each of the other four grades were received at the laboratory. Samples were screened by means of a specially designed shaker screen operated by pulley-driven eccentrics running at a speed of 80 revolutions per minute. Five screens were used perforated respectively with 4-in., 2-in., 1-in., ½-in. and ¼-in. holes. In this way the sample was divided into six parts whose size limits were as designated by the headings of columns 2 to 7 in Table II. These parts

TABLE I—THE CHEMICAL ANALYSIS AND HEATING VALUE OF THE COALS

Grade of coal	Proximate analysis, coal as fired					Calorific values			Ultimate analysis, coal as fired				Moisture in coal determined from sample taken at mine, per cent
	Moisture, per cent	Volatile matter, per cent	Fixed carbon, per cent	Ash, per cent	Sulphur separately determined, per cent	Per lb. of coal as fired, B.t.u.	Per lb. of dry coal, B.t.u.	Per lb. of combustible, B.t.u.	Carbon, per cent	Hydrogen, per cent	Nitrogen, per cent	Oxygen, per cent	
Mine run.....	8.14	34.18	47.92	9.76	0.95	11,873	12,926	14,463	66.63	4.28	1.55	8.69	7.82
2-in. by 3-in. nut.....	8.60	34.83	47.70	8.87	0.88	11,957	13,082	14,487	67.50	4.36	1.38	8.42	8.48
3-in. by 6-in. egg.....	8.82	34.57	48.56	8.06	0.94	12,071	13,239	14,523	68.19	4.50	1.51	7.99
2-in. lump.....	9.27	34.46	47.49	9.07	0.88	11,817	13,023	14,469	66.34	4.23	1.49	8.73
2-in. screenings.....	9.25	32.05	48.12	10.59	0.85	11,550	12,727	14,408	65.74	4.43	1.48	7.66
1¼-in. screenings..	9.09	32.34	48.01	10.57	0.97	11,557	12,711	14,385	65.49	4.35	1.43	8.10	9.07

such an average. During tests run at this medium rate about 23,000 lb. of water were evaporated an hour under the prevailing conditions, from 3,100 to 4,300 lb. of coal were fired per hour, and the engine was worked at 33 per cent cut-off and at about 19 miles an hour, developing approximately 1,300 indicated horse power and about 22,500 lb. drawbar pull. During tests when the engine was worked at the high rate of evaporation, about 43,000 lb. of water were evaporated an hour, the hourly coal consumption varied from about 7,000 to 9,300 lb., the cut-off and speed were respectively 55 per cent and 26 miles per hour, while the horse power was about 2,200, and the drawbar pull about 28,500 lb.

THE COAL USED

The averages of the coal analyses for all tests made with each grade of coal are presented in Table I. The uniform-

were then weighed and the ratios of their weights to that of the original sample were calculated.

All grades except the mine run and lump were fired in exactly the condition in which they arrived at the laboratory, except for the breakage incident to unloading and the insignificant breakage due to shoveling into the charging wagons. Since, however, the mine run and the lump coals contained as usual a considerable proportion of lumps too large for proper firing, the attempt was made to break these two grades down to the extent to which, in the judgment of those in charge of the tests, these grades are generally broken down at the coal chute. These two coals as fired contain, therefore, a smaller proportion of large lumps than when they were received.

THE TESTS

The locomotive used during the tests was loaned for the purpose by the Baltimore & Ohio. It is of the Mikado type developing 54,587 lb. tractive effort and was built by the

*From the report of the committee on fuel tests of the International Railway Fuel Association, presented at the 1917 convention.

Baldwin Locomotive Works during the summer of 1916. It arrived at the laboratory in excellent condition.

The boiler was of the wagon-top type with radial stays, carrying 190 lb. pressure and having 3,630 sq. ft. of heating surface. It was equipped with a Schmidt 34-element superheater, having a heating surface of 1,030 sq. ft., a Street stoker, and a Security brick arch carried on four tubes. The front end was self-cleaning and was equipped

and each rate of combustion. In view of this uniformity we are entirely warranted in using the average values for the various groups and in basing conclusions upon them. These averages of equivalent evaporation per pound of dry coal are therefore assembled in Table III together with the averages of the rate of evaporation per square foot of heating surface per hour.

The relations shown in Table III stand out more clearly

TABLE II—SIZE ELEMENTS OF THE COALS AS RECEIVED AT THE LABORATORY

Grade of coal	Per cent over 4-in. screen	Per cent through 4-in., over 2-in. screen	Per cent through 2-in., over 1-in. screen	Per cent through 1 in., over ½-in. screen	Per cent through ½-in., over ¼-in. screen	Per cent through ¼-in. screen	Total
Mine run	29.6	22.3	16.8	11.4	7.4	12.5	100.0
2-in. by 3-in. nut	...	63.9	30.3	2.8	1.1	1.9	100.0
3-in. by 6-in. egg	41.0	48.3	5.3	2.0	1.1	2.3	100.0
2-in. lump	61.6	26.4	7.5	1.9	.9	1.7	100.0
2-in. screenings	33.2	25.7	14.2	26.9	100.0
1½-in. screenings	4.5	37.9	20.0	37.6	100.0

with a plain 6-in. round nozzle-tip without bridge or split, which was used throughout all tests. The total air opening through the grates amounted to 17 sq. ft. or 24.4 per cent of the 69.8 sq. ft. of grate area. The area of the air inlet

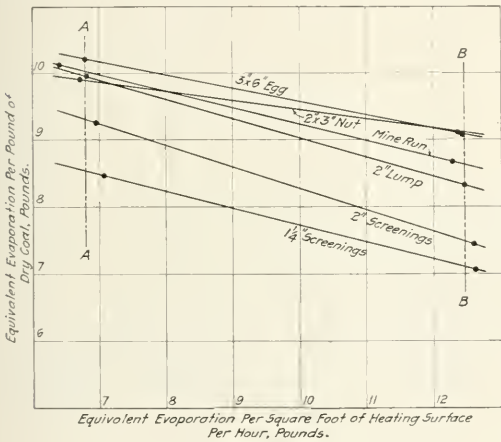

Fig. 1—The Relation Between Equivalent Evaporation Per Pound of Dry Coal and the Rate of Evaporation

to the ash pan amounted to 8.3 sq. ft. or 49 per cent of the air opening through the grates. A Franklin pneumatic door of the butterfly type was used during all tests except those

in Fig. 1. Inspection of Fig. 1 reveals, as usual, for all grades a sharp decrease in evaporation as the rate of evaporation increases. The rate of this decrease is nearly alike for all grades except the 2-in. by 3-in. nut, for which it is roughly one-half of that for the other grades. This change in evaporation with rate of evaporation makes it necessary to reduce the values of evaporation to a common rate before drawing final comparisons between the various grades. To effect this reduction the rates of evaporation for the medium rate tests have been averaged and this average—6.70 lb. per sq. ft. of heating surface per hour—has been represented by the vertical line *AA* in Fig. 1. Similarly the average high rate—12.46 lb. per sq. ft. of heating surface per hour—is defined by the line *BB*. If we measure off the vertical distances on *AA* at the points where this line is intersected by the performance lines for the various grades we obtain six

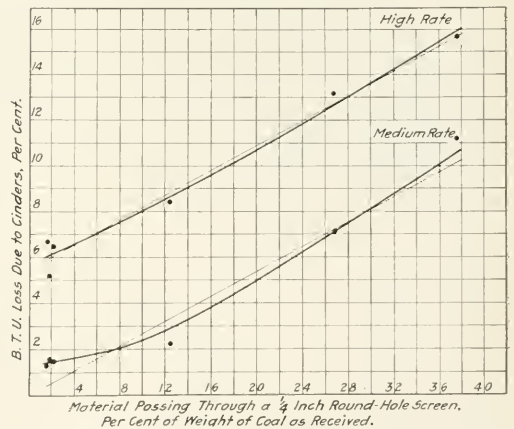

Fig. 2—The Cinder Loss in Relation to the Fine Material in the Coal

TABLE III—EQUIVALENT EVAPORATION PER POUND OF DRY COAL

Grade of coal	For the medium rate tests		For the high rate tests	
	Equivalent evaporation per lb. of dry coal, lb.	Equivalent evaporation per hour per sq. ft. of heating surface, lb.	Equivalent evaporation per lb. of dry coal, lb.	Equivalent evaporation per hour per sq. ft. of heating surface, lb.
3-in. by 6-in. egg	16.21	6.78	9.09	12.42
Mine run	10.12	6.40	8.66	12.28
2-in. lump	9.95	6.82	8.32	12.46
2-in. by 3-in. nut	9.96	6.72	9.11	13.39
2-in. screenings	9.25	6.95	7.43	12.59
1½-in. screenings	8.47	7.07	7.06	12.61

with the two sizes of screenings, which were fired by means of the Street stoker.

An inspection of the values of equivalent evaporation per pound of dry coal as obtained from each test disclosed great uniformity among the values applying to each grade of coal

values of equivalent evaporation per pound of dry coal, one for each grade, which are rigidly comparable; in like manner the evaporation values defined by the intersections with the line *BB* are comparable.

At the medium rate the four larger grades gave nearly the same performance, the maximum difference among them being but four per cent. The steam production per pound of egg coal was two per cent greater than with the mine run, while with the lump and the nut it was respectively one per cent and two per cent less than with mine run. The performance with 2-in. screenings was seven per cent less

and with 1¼-in. screenings 15 per cent less than with mine run. If we assume that mine run coal on the tender is worth \$2 per ton the relative worth on the tender of the other grades during the medium rate tests was:

3-in. by 6-in. egg.....	\$2.04
2-in. lump.....	1.98
2-in. by 3-in. nut.....	1.96
2-in. screenings.....	1.86
1¼-in. screenings.....	1.70

At the high rate the 2-in. by 3-in. nut coal gave the best performance, producing six per cent more steam than the mine run; the 3-in. by 6-in. egg comes next with an evaporation 5 per cent more than that of the mine run; while the 2-in. lump evaporated three per cent less. At this rate of evaporation the 2-in. screenings and the 1¼-in. screenings produced per lb. respectively 13 per cent and 18 per cent less steam than the mine run. If we again assume that mine run is worth on the tender \$2 per ton, the relative worth of the other grades during the high rate tests was as follows:

2-in. by 3-in. nut.....	\$2.12
2-in. lump.....	2.10
2-in. by 3-in. nut.....	1.94
2-in. screenings.....	1.74
1¼-in. screenings.....	1.64

In considering the cinder losses as here presented it should be borne in mind that all of the coal tested was of one kind, that is, it came from one mine. Coals possessing other physical characteristics might show somewhat different results as to cinder losses under the conditions of the tests here considered. It should also be remembered that for a given rate, medium or high, the draft was, for all grades of coal, practically constant.

The average heating value of the stack cinders for all medium rate tests was 8,635 B. t. u. and the average value for all high rate tests was 10,854 B. t. u. The heating values of the cinders from the medium rate tests with screenings were higher than corresponding values from other grades of coal. When the losses are expressed as B. t. u. percentages, the average loss from the screenings was roughly five times as great as the average loss from the larger coals during the medium rate tests. For the high rate tests the average loss from screenings was more than twice as great as the average loss from the larger coals.

The data indicates that with very fine coals such as screenings the cinder loss is large even at medium rates of combustion and with comparatively low front-end draft; but that under these conditions the cinder loss is not serious for the larger coals even when they contain a considerable amount of fine material, as in mine run coal. For conditions involving high rates of combustion and strong drafts, the stack cinder loss is a serious one for all grades of coal.

Fig. 2 shows the relation existing between the loss due to stack cinders and the amount of ¼-in. or smaller material in the coal as received. The light straight lines show for both rates, a uniform increase of one per cent in cinder loss for each 3.7 per cent increase in the ¼-in. material in the coal. The straight line represents the plotted points of the high rate tests closely but does not so well represent the points plotted for the medium rate tests.

Generally speaking, the relations between the various elements of the heat balance for the different grades are nearly the same for the medium rate tests as for the high rate tests. All losses except those due to stack cinders are fairly constant for all grades of coal and the differences in the amount of heat absorbed by the boiler are accounted for, almost entirely, by the variations in the losses due to stack cinders.

CONCLUSIONS

Comparing mine run with 3-in. by 6-in. egg, we find the egg was 2 per cent better at the low rate and 5 per cent better at the high rate. The B. t. u. value of the egg was 2 per cent more than that of the mine run. This accounts

for the difference at low rate and brings the high rate difference to 3 per cent, but when it is considered that the stack cinders were 2.2 per cent of the egg fired at low rate and 3.1 per cent of the mine run fired at low rate and 7.2 per cent of the egg fired at high rate and 9.0 per cent of the mine run fired at high rate, it is evident that the increased cinder loss of mine run coal over 3-in. by 6-in. egg is in part offset by the better combustion of the smaller particles of coal which exist in greater percentage in the mine run.

The higher standing of 2-in. by 3-in. nut than mine run at high rate is due to the lesser cinder loss and to the even and uniform condition in which it is possible to keep a fire using 2-in. by 3-in. nut. At the medium rate we believe the lower standing of the 2-in. by 3-in. nut in comparison with mine run was due to the necessity of carrying too thin a fire with the nut. At the low rate the 2-in. lump is one per cent below the mine run and three per cent at the high rate. When firing 2-in. lump it was reduced to such size that about 74 per cent would pass through a 5-in. round opening, whereas all of the mine run as fired would pass through that size opening. The 2-in. lump was cracked to about the same size as it would be at a coal chute where the coal is cracked and passes through breaker bars spaced 5-in. in the clear. There were consequently not the large pieces in the mine run that there were in the lump and the committee concludes that cracking coal so it will pass through a 5-in. round or 6-in. round opening is worth more than it costs.

Under ordinary circumstances mine run coal from this district can be purchased at from 15 cents to 25 cents less per ton than 2-in. lump, and 2-in. by 6-in. egg or 3-in. by 6-in. egg, and the egg and lump are often considered more economical and satisfactory than Mine Run. Where this price differential exists, it would pay to increase supervision to the point where mine run can be handled as satisfactorily by all firemen as the lump and egg.

At the low rate the 2-in. screenings were 9.2 per cent better than the 1¼-in. screenings, and at the high rate 5.2 per cent better than the 1¼-in. screenings. At medium rate the cinder losses are not serious for the four hand-fired grades, but at high rate they are greater than is desirable. At both medium and high rates with the stoker fired grades these losses are very high though not enough to wipe out the ordinary price differential existing between the hand fired and stoker fired grades. This shows the importance of using on stoker engines as large screenings as the price differential will permit.

One of the problems which is beginning to confront railroads using stokers is what fuel efficiency will be obtained when using mine run hand fired in comparison with screening this mine run into 2-in. lump for hand fired engines and 2-in. screenings for stoker fired engines. Assuming that the mine run splits into 52 per cent of lump and 48 per cent of screenings, we find that using mine run as 100 per cent the lump and screenings give 96 per cent of the efficiency of mine run at the low rate and 92 per cent at the high rate. This of course applies to both lump and mine run as cracked on these tests.

We recommend that all tests and data covering locomotive tests and boiler design be accompanied by a complete description of the character and size of the coal, also that the coal fired is of an average grade.

The difference between mine run, 2-in. lump, 3-in. by 6-in. egg, and 2-in. by 3-in. nut are such that they could not have been determined by the ordinary road tests where only two or three round trips using each grade of coal would have been made, and the committee wishes to call attention to the fact that a very large number of road tests must be made to get a reliable average.

The report was signed by J. G. Crawford, chairman, H. B. Brown, W. P. Hawkins, O. P. Hood, L. R. Pyle, W. L. Robinson and E. C. Schmidt.

SANTA FE 2-8-2 TYPE LOCOMOTIVE

Same Tractive Effort but Increased Power Capacity,
as Compared with an Earlier Class of the Same Type

AN order of heavy Mikado type locomotives, built by the Baldwin Locomotive Works, has recently been placed in service by the Atchison, Topeka and Santa Fe. These engines are coal burners and were developed from the design of a lighter Mikado type locomotive, a number of which were built in 1916. The new design was worked out conjointly by the railway company and the builders, and existing Santa Fe standards were used generally throughout the construction. The character of the change in the design is shown by the following comparison of the leading dimensions of the new locomotives with those of the previous engines:

Date built	Cylinders, dia. and stroke, in.	Diameter drivers, in.	Steam pressure, lb.	Grate area, sq. ft.	Water heating surface, sq. ft.	Superheating surface, sq. ft.	Weight on drivers, lb.	Weight, total engine, lb.	Tractive effort, lb.
1916.....	25 by 32	57	200	58.5	4,111	880	228,000	292,400	59,600
1917.....	27 by 32	63	196	66.5	4,614	1,086	228,900	314,900	59,800

Wheel load limitations prohibited a material increase in the weight on drivers, as compared with the design of 1916; and while the new engines are heavier, the additional weight

seam, which is placed on the right hand side of the center line.

The boiler accessories include a power-operated fire-door and grate shaker. The minimum air opening specified for the ash-pan is 15 per cent of the grate area. The throttle valve is fitted with an auxiliary drifting valve.

The cylinders are designed with direct exhaust passages of ample area, free from abrupt bends. Gun iron is used for the cylinder and steam chest bushings, piston and valve bull and packing rings, and crosshead shoes. The piston heads are of rolled steel, and the crosshead bodies of .40 carbon cast steel of the Laird design. Special steels are used for the piston rods, valve stems, main and side rods and main crank pins. The Baker valve motion is applied, and is controlled by the type "B" Raggonnet power reverse gear. Fifty per cent of the weight of the reciprocating parts is balanced.

The frames are of substantial design, the main sections having a width of $5\frac{1}{2}$ in., while the depth over the front driving pedestals is $8\frac{1}{2}$ in., and over the remaining pedestals $7\frac{1}{2}$ in. The top and bottom rails are tied together between adjacent pairs of pedestals, by strong vertical ribs of I-section. These ribs carry the equalizing beam fulcrum

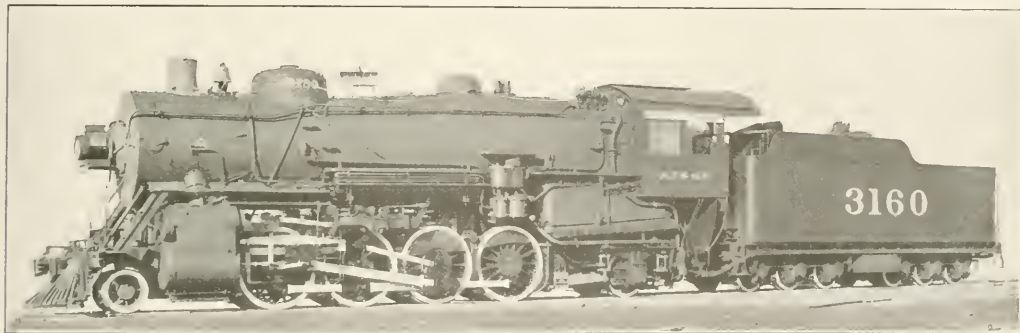

Mikado Type Locomotive Recently Built for the A. T. & S. F.

is carried on the front and rear trucks. The principal advantage derived from this greater weight is the increased steaming capacity of the enlarged boiler. With this additional steam supply the larger cylinder horse-power incident to the use of driving-wheels of greater diameter can be developed. For an increase in total weight of not quite eight per cent there has been an increase in water heating surface of over 11 per cent. The starting tractive efforts, with steam pressures giving approximately the same ratio of adhesion, are practically the same for both locomotives, but the larger cylinders, wheels and boilers of the new engines give them greater horse-power capacity. This additional power will be utilized in maintaining higher speed with the same or possibly a little greater tonnage.

The boiler is of the extended wagon top type, designed for a pressure of 225 lb. per sq. in., but in service carrying 190 lb. It contains a 43-element superheater, and the firebox is equipped with a brick arch supported on four tubes. An auxiliary dome, mounted over an opening in the shell of sufficient size for inspection purposes, is placed back of the main dome and on the same course with it. A single liner is placed under both domes; it also covers the longitudinal

pins, which are fitted into case-hardened bushings. Transverse braces are applied at each pair of driving pedestals. Three of these braces—two at the second pair of pedestals and one at the fourth pair—not only brace the pedestals through their entire depth, but are also extended to form long braces for the top rails. They support, respectively, the guide yoke, the valve motion bearer, and a boiler waist sheet.

The shoes and wedges are of cast steel, and the driving boxes are of the same material, with brass hub faces. Long main driving boxes are used. The tires are all flanged, and flange oilers are applied to the leading drivers.

The leading truck is of the Economy constant resistance type, and the trailing truck is of the Hodges type. Each truck is equalized with two pairs of driving-wheels. The arrangement of cross equalization frequently applied by the builders, consisting of two transverse beams connected by a central, vertical link, is used between the rear drivers and trailing truck.

The cab is placed well back, thus providing ample deck space. Special attention has been paid to the location of the cab fittings, in order to place all levers, valves, etc., with-

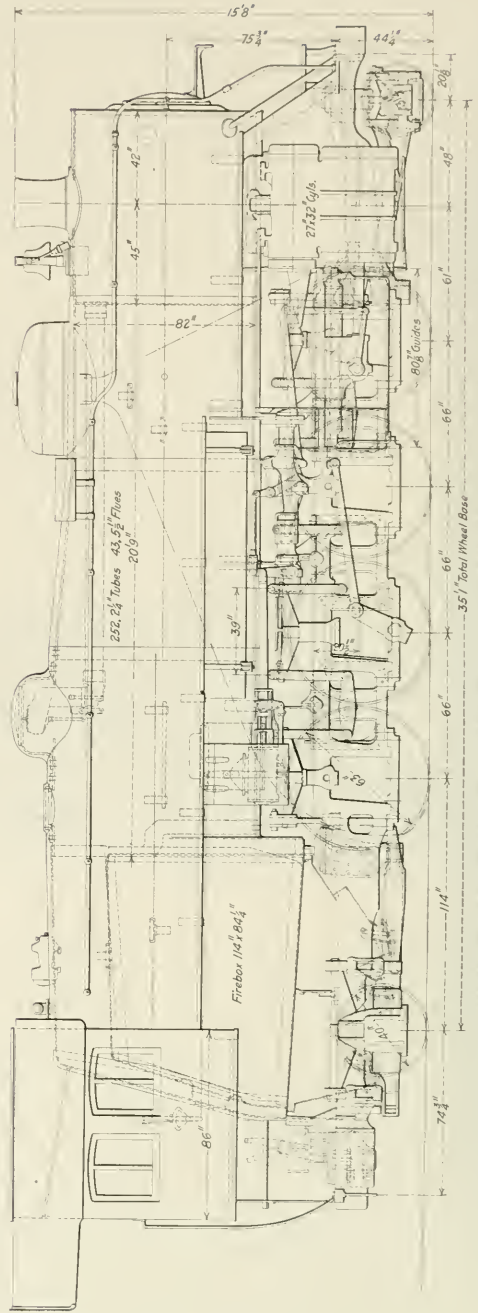
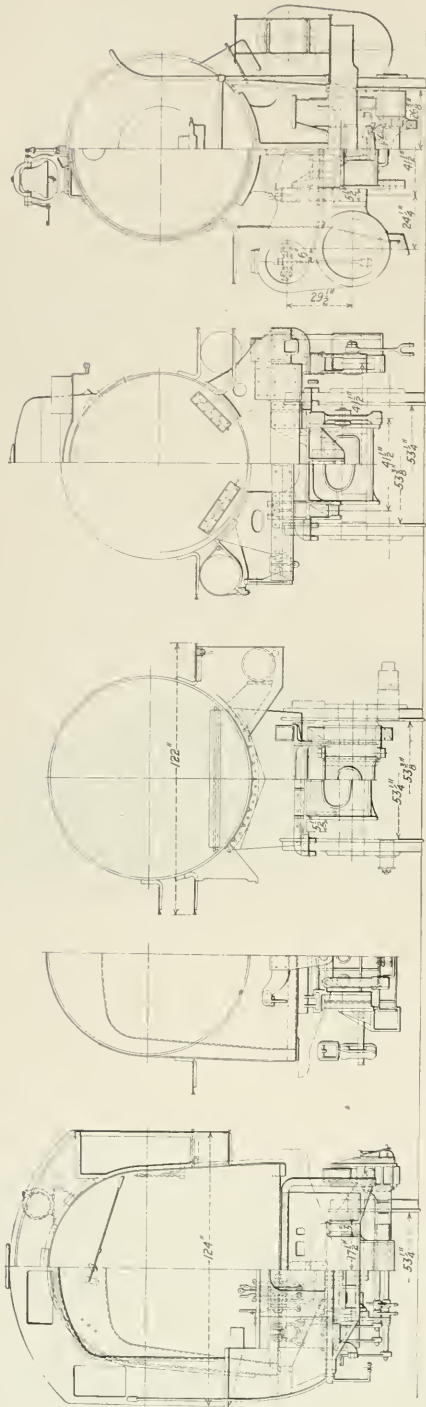

General Arrangement and Sections of the Atchafon, Topeka & Santa Fe Mikado Type Locomotive

in easy reach of the crew, and to locate the steam, air and water gauges where they can easily be read.

In accordance with Santa Fe practice, these locomotives are fitted with steam heat equipment so that they can, in cases of emergency, be used on passenger trains.

The tender is carried on two six-wheeled trucks, which are equipped with clasp brakes and Standard rolled steel wheels. The tender frame is of cast steel, in one piece. The buffer between the engine and tender is of the radial type. The Locomotive Stoker Company's slope sheet type of coal pusher is applied.

The leading dimensions are given in the table:

General Data	
Gage	4 ft. 8 1/2 in.
Service	Freight
Fuel	Bit. coal
Tractive effort	59,800 lb.
Weight in working order	314,900 lb.
Weight on drivers	228,900 lb.
Weight on leading truck	31,000 lb.
Weight on trailing truck	55,000 lb.
Weight of engine and tender in working order	563,900 lb.
Wheel base, driving	16 ft. 6 in.
Wheel base, total	35 ft. 1 in.
Wheel base, engine and tender	71 ft. 8 1/2 in.
Ratios	
Weight on drivers ÷ tractive effort	3.8
Total weight ÷ tractive effort	5.3
Tractive effort × diam. drivers ÷ equiv. heating surface*	603.4
Equivalent heating surface* ÷ grate area	93.5
Firebox heating surface ÷ equiv. heating surface,* per cent.	4.3
Weight on drivers ÷ equivalent heating surface*	36.7
Total weight ÷ equivalent heating surface*	50.4
Volume both cylinders	21.2 cu. ft.
Equivalent heating surface* ÷ vol. cylinders	291.7
Grate area ÷ vol. cylinders	3.2

Kind		Simple
Diameter and stroke		27 in. by 32 in.
Valves		
Kind		Piston
Diameter		15 in.
Wheels		
Driving, diameter over tires		63 in.
Driving, thickness of tires		3 1/2 in.
Driving journals, main, diameter and length		12 in. by 20 in.
Driving journals, others, diameter and length		11 in. by 12 in.
Engine truck wheels, diameter		31 1/2 in.
Engine truck journals		7 in. by 12 in.
Trailing truck wheels, diameter		40 in.
Trailing truck journals		9 in. by 14 in.
Boiler		
Style		Wagon top
Working pressure		190 lb. per sq. in.
Outside diameter of first ring		82 in.
Firebox, length and width		114 in. by 84 1/2 in.
Firebox plates, thickness		Tube, 1/2 in.; others, 3/8 in.
Firebox, water space		Front, 6 in.; sides, 5 in.; back, 4 1/2 in.
Tubes, number and outside diameter		252-2 1/2 in.
Flues, number and outside diameter		43-5 1/2 in.
Tubes and flues, length		20 ft. 9 in.
Heating surface, tubes and flues		4,348 sq. ft.
Heating surface, firebox, including arch tubes		266 sq. ft.
Heating surface, total		4,614 sq. ft.
Superheater heating surface		1,086 sq. ft.
Equivalent heating surface*		6,243 sq. ft.
Grate area		66.8 sq. ft.
Tender		
Tank		Water bottom
Frame		Cast steel
Weight		249,000 lb.
Wheels, diameter		33 in.
Journals, diameter and length		5 1/2 in. by 10 in.
Water capacity		12,000 gal.
Coal capacity		16 tons

* Equivalent heating surface = total evaporative heating surface + 1.5 times the superheating surface.

ONE MONTH OF FEDERAL CONTROL

The Director General Appoints Three Regional Directors, a Wage Commission and Other Assistants

DIRECTOR GENERAL OF RAILWAYS, Wm. G. McAdoo, has spent the month of January in perfecting his organization and in doing his best to help the country's railways in fighting some of the worst weather from the transportation standpoint known for any January in the last 50 years.

THREE DIVISIONAL DIRECTORS APPOINTED

The director general on January 18 issued General Order No. 4 announcing that for purposes of operation the railroads of the United States will be classified as Eastern, Southern and Western Railroads.

A. H. Smith, president of the New York Central, has been appointed regional director, with office at New York, in charge of the operation of Eastern railroads.

C. H. Markham, president of the Illinois Central, has been appointed regional director, with office at Atlanta, in charge of the operation of Southern railroads.

R. H. Aishton, president of the Chicago & North Western, has been appointed regional director, with office at Chicago, in charge of the operation of Western railroads.

Orders issued by the gentlemen named in their capacity as regional directors will be issued by authority of the director general and will be respected accordingly.

RAILROAD WAGE COMMISSION

In his next order, General Order No. 5, Mr. McAdoo announced the appointment of a Railroad Wage Commission to make a general investigation of the subject of railroad wages in the United States. The members of the commission are Franklin K. Lane, Secretary of the Interior, Charles C. McChord, member of the Interstate Commerce

Commission, J. Harry Covington, chief justice of the supreme court of the district of Columbia, and William R. Wilcox of New York. The members of this commission are all men who have had experience in dealing with problems like that referred to it.

The commission held its first meeting at Washington on January 21 and organized by electing Secretary Lane as chairman. W. A. Ryan was appointed secretary of the commission. It was decided to appoint a board of four examiners and a statistical board of three members. Public hearings will be held at Washington and it was stated that some results could be expected in about 60 days.

The commission has established itself in offices in the Department of the Interior building. F. W. Lehmann has been appointed general counsel and a board of statisticians has been appointed consisting of Charles P. Neill, manager of the Bureau of Information of the Southeastern Railroads and formerly United States Commissioner of Labor; F. A. Burgess, assistant grand chief of the Brotherhood of Locomotive Engineers; and A. O. Wharton, who is president of the Railroad Department of the American Federation of Labor.

A tentative program of hearings has been outlined, at which the following labor leaders will be heard: T. H. Garvey, representing maintenance of way employees; E. H. Norton, representing the Order of Railway Station Agents; W. G. Lee, president of the Brotherhood of Railroad Trainmen; A. B. Garretson, president of the Order of Railway Conductors; S. E. Heberling, president of the Switchmen's Union; W. S. Carter, representing the Brotherhood of Locomotive Firemen and Enginemen; and A. O. Wharton, representing the mechanical employees, helpers and apprentices

and railway clerks. It is understood that railroad officers will also be heard.

The commission is acting under the authority of General Order No. 5, issued by the Director General, which provides that:

"The commission shall make a general investigation of the compensation of persons in the railroad service, the relation of railroad wages to wages in other industries, the conditions respecting wages in different parts of the country, the special emergency respecting wages which exists at this time owing to war conditions and the high cost of living, as well as the relation between different classes of railroad labor.

"The commission shall begin its labors at once, and make report to the Director General, giving its recommendations in general terms as to changes in existing compensations that should be made.

"Officers, agents and employees of the railroads are directed to furnish to the Railroad Wage Commission upon request all information it may require in the course of its investigations."

ECONOMY IN EXPENDITURES

The director general on January 28 issued his first order looking toward economy in the expenditure of railroad operating revenues during the period of the war. This was General Order No. 6, issued to officers and directors of railroad companies, as follows:

"During the period of possession, operation, and government control of railroads, it is necessary that officers, directors, and agents of railroad companies be very careful in the handling of moneys and in the dealing with transportation matters. Without attempting at this time to give general directions, there are a few matters involving the expenditure of moneys for purposes having no direct relation to transportation, which should receive immediate attention: as well as the issuance of free transportation.

"It is therefore ordered that the carriers' operating revenues shall not be expended:

"1. For the payment of agents or other persons who are employed in any way to affect legislation.

"2. For the employment of attorneys who are not actually engaged in the performance of necessary legal work for the company.

"3. For the payment of the expenses of persons or agencies constituting associations of carriers unless such association is approved in advance by the Director General.

"4. For any political purpose or to directly or indirectly influence the election of any person or an election affecting any public measure.

"No passes or free transportation shall be issued by any carrier under federal control or any official of such carrier unless the issuance of such free transportation is expressly authorized by the Act of Congress entitled 'An Act to Regulate Commerce, approved February 4, 1887, and Amendments thereto'; and any such passes or free transportation heretofore issued not in conformity with said act must be recalled.

"This order applies to all carriers under federal control, whether inter-state or intra-state."

The order as it applies to passes simply extends the provisions of the federal law to cover intra-state as well as inter-state transportation. Some states have no anti-pass laws and the laws in many states are more liberal than the federal law, many of them allowing or even requiring railroads to give free transportation to public officials.

ALL NEW LOCOMOTIVES FOR EASTERN LINES

One of the most important matters that has come before the director general has been that of motive power. The eastern roads are now using some 100 Consolidation loco-

motives built for the American railway lines in France; during the last few weeks the larger part of the 165 locomotives on western roads ordered sent to the more congested eastern roads have been so diverted; steps are being taken to secure some 200 locomotives intended for Russia, but most important of all is the order of the director general that the locomotive builders should deliver to specified eastern lines all the locomotives turned out in January, February and March, regardless of the roads that ordered them. About 150 are to be delivered in January, about 250 in February and 250 in March.

Mr. McAdoo has been in conference with officers of the locomotive companies in the effort to secure early delivery of engines which have been ordered and in making arrangements for obtaining the use of locomotives ordered by the Russian government. As one of the great sources of difficulty has been the shortage of labor for repairing locomotives, efforts have been made to transfer men from the western and southern lines to the eastern lines.

Bearing upon this locomotive situation and upon the weather conditions is the statement issued by Commissioner McChord on January 29 summarizing reports of the Interstate Commerce Commission's inspectors relative to the congestion of freight traffic on the Pennsylvania Railroad:

"A condition of serious congestion exists on the Pennsylvania Railroad in the Philadelphia district and in the Pittsburgh district and the line between is practically blocked with cars destined for those two points and beyond.

"In the Philadelphia yards the normal daily movement of cars is 2,925. The reports covering the period from January 14 to January 25, inclusive, except for January 19 for which no report was furnished, show that the maximum daily movement was 2,210 cars, and the average was less than 2,000. And on these same dates there were from 54 to 61 trains left over in the Philadelphia yards ready for movement but for which no locomotives were available. The number of cars left in the yards varied from 3,825 to 5,750. During this entire period there were from 1,400 to 2,200 empty coal cars in the yard for movement westward, and the number actually forwarded westward varied from 119 to 585 per day.

"On the Middle division, for movement in both directions, there were approximately 11,000 cars left over each day. While at times the business accepted by the Philadelphia and the Pittsburgh divisions was restricted, the traffic handled when not restricted by connecting divisions frequently did not exceed 50 or 60 per cent of the normal business.

"In the Pittsburgh district, the average number of trains for which no locomotives were available in Pitcairn and Conway yards was more than 100 trains daily, and there were approximately 10,000 cars left over in those two yards each day.

"For four days on which the information was furnished, coal mines in the Pitcairn district were supplied with a very small percentage of empties required, in one instance 324 cars being required and only 24 furnished on account of no other empties being available.

"The principal cause assigned for the serious congestion on this railroad is shortage of motive power, but it is clearly apparent that the real cause is the impaired condition of motive power available, as well as the lack of adequate facilities for properly maintaining it, and excessive terminal delays. For example, the inspector reports that the facilities for maintaining the 149 locomotives assigned to Pitcairn are entirely inadequate, and only such repairs as are absolutely required are made, the demand for power being so great that minor repairs and other work which would greatly increase efficiency of locomotives are left undone; further, that even if more locomotives were assigned there, it is doubtful if they could be properly maintained or promptly handled. And at Altoona, on January 23, the report for that

date being typical, all of the 50 stalls of the engine-house were occupied by locomotives undergoing repairs, 190 of the 230 locomotives despatched were repaired on inspection pit and storage tracks where there was no shelter or protection from snow and weather. Under such conditions, and in the crowded and unheated enginehouses existing at many points, some of which are too small to accommodate the large locomotives in use today, it is not reasonable to expect that necessary work can be promptly and efficiently performed. Vigorous action must be taken to improve the condition of motive power before relief can be expected."

BLIZZARDS HANDICAP RAILROADS

Storms and continued cold weather together have made the month just past the worst January from the railroad standpoint in 50 years. The weather has prevented the realization of the relief that was hoped from the five-day closing down of industry and because of it "freight moving week" was far below expectations. Serious storms were met both in New York and Chicago; and along the Ohio river and in eastern Kentucky floods, floating ice and wash-outs are causing considerable damage.

The succession of blizzards and low temperatures has made it impossible to raise the embargo against general freight ordered on January 23 on the Pennsylvania, Baltimore & Ohio and Philadelphia & Reading, which it was expected would be in force but a few days. While one of the most serious conditions, the inability of ships to embark, because of the delay in obtaining bunker coal, has been remedied, many of the eastern roads have been unable to handle much new freight except food, fuel and necessary government freight for several days and most of the reports received at Mr. McAdoo's office have been discouraging,

while the daily reports of the Interstate Commerce Commission's inspectors from various terminal points, received by Commissioner McChord, continue to show conditions approaching a paralysis of transportation at many points, due to weather conditions, congestion in yards, shortage of crews, and engines and cars in bad order with a shortage of labor to repair them.

A. H. Smith, regional director in charge of the eastern lines, reported on January 26 that it had been necessary to suspend operations in Northern New York on account of a heavy snow storm and that on account of a very severe snow storm at Chicago all belt roads had discontinued accepting cars. Assurances that an adequate supply of cars will be furnished for the transportation of food supplies for export to the allies was given by Director General McAdoo at a conference with commissioners representing the British, French and Italian governments on Saturday and some discussion was given to the question of diverting more export freight to gulf ports.

Director General McAdoo has instructed, in the matter of embargo on the Pennsylvania Lines east of Pittsburgh, Baltimore & Ohio east of the Ohio River, and Philadelphia & Reading, that the following exceptions be made:

- (a) Food for animals.
- (b) Material used in the operation and upkeep of coal mines.

To provide for the rail movement of food and supplies consigned to the French, British and Italian governments, for ports on the North Atlantic seaboard, already accepted or under permit, arrangements have been made to consolidate these shipments and move them in solid trains, or groups of cars, east from Chicago, St. Louis and intermediate terminals.

PENNSYLVANIA ELECTRIC LOCOMOTIVE

A Description of Interesting Details in the Running Gear Construction and in the Electrical Equipment

TESTS have recently been made on the Philadelphia-Paoli electrified section of the main line of the Pennsylvania Railroad, of the experimental electric locomotive which has been built for main line freight service by the Pennsylvania Railroad and the Westinghouse Electric & Manufacturing Company. A brief description of this loco-

effort of approximately 87,000 lb. The continuous rating is 4,000 hp. or 72,000 lb. tractive effort at a speed of 20.85 miles an hour, with the motors connected in parallel. For starting and slow speed operation, a "cascade" connection of the two motors on each truck unit is provided. When regenerating at continuous capacity, the locomotive is capable

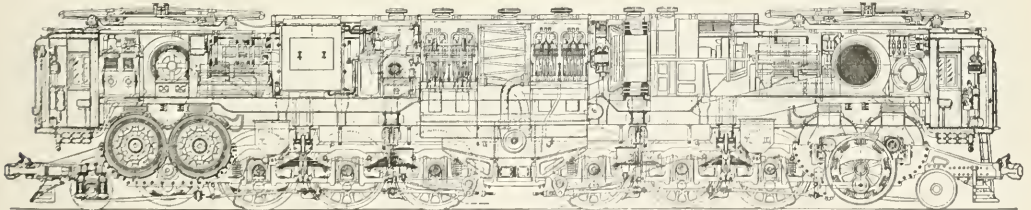

Longitudinal Section of the Pennsylvania Electric Locomotive

motive, including the principal dimensions, was published in the July issue of the *Railway Mechanical Engineer*, page 379. It is the largest electric locomotive which has so far been built, having a starting tractive effort of 130,000 lb. and a total weight of 240 tons, of which 198 tons is carried on the drivers.

The locomotive has a nominal one hour rating of 4,800 hp. at 20.8 miles an hour, which is equivalent to a tractive

effort of returning to the trolley system 4,400 hp. at a speed of 21 miles an hour.

In service between Altoona and Johnstown, where it is the intention eventually to use locomotives of this type, it is proposed to operate trains with one locomotive at the head end and one pushing. The continuous capacity at a speed of 20.85 miles an hour enables a trailing load of 2,300 tons to be hauled up a one per cent grade, 4,100 tons up a .5 per

cent grade, or 11,000 tons on level track. Two locomotives operating under the proposed plan are expected to handle 3,900 tons westbound, where the ruling grade is 2 per cent, and to handle 6,300 tons eastbound over a ruling grade of 1.33 per cent. The speed chosen is considered to be about the maximum desirable for the operation contemplated and is governed by the size of trains as well as the characteristics of profile and alinement.

In the previous article was given a general description of the construction of the locomotive, but there are a number of features of the locomotive, both mechanical and electrical, which are worthy of more detailed consideration.

The method of securing a rigidly maintained gear center distance may be seen in the illustration showing the flexible jack shaft gear and motor pinions with the casing removed. The jack shaft bearing brass consists of a solid bronze bushing pressed into an eye in the side frame. The removal of this brass involves the removal of the main gear center from the jack shaft. The armature bearings are contained in housings which are fitted into pockets 27 in. wide by 14 $\frac{3}{8}$ in. deep in the top of the frame casting. These pockets depart from the rectangular in that the sides are tapered 1 in. in 16 in., the housing being forced into the pockets under a pressure sufficient to produce local stresses in excess of any that will be imposed in service. The housings are then bolted in place both horizontally and vertically. The center distances between the gear and the motor pinions are, therefore, as securely fixed as if all three bearings were in an integral casting.

The active iron of both motor stators on each truck is mounted in a unit motor frame and locomotive cross-tie casting, which also surrounds the jack shaft. The armature bearings are arranged for oil ring lubrication, while the jack shaft is fitted with oil and waste lubrication, a large

which is located in a counterbore in the outer face of the gear center. A heavy key in the taper fit insures the proper quarter of the crank pin. The crank pin is 8 $\frac{1}{4}$ in. in diameter and has a throw of 30 in. Opposite its center is a lead filled counterbalance with proper angular offset to compensate for transverse unbalance. A complete counterbalance is thus secured for all operating speeds.

The flexible gear is of the Westinghouse type which was

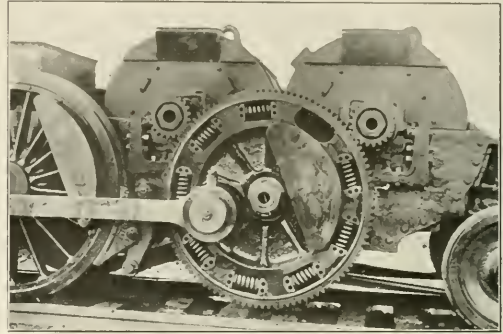

Motor and Jack Shaft Mounting

developed for railroad service and has previously received wide application both on cars and locomotives. This, however, is the first commercial application in connection with rod drive and no other railroad application approaches it in the amount of power transmitted. The gear has a face 10 in. in width which is a radical departure from previous



Pennsylvania Electric Locomotive Hauling an Idle Steam Locomotive and Freight Train

waste cavity being provided in the side frame casting above the jack shaft bearing.

The body of the jack shaft is 11 $\frac{7}{8}$ in. in diameter with a long taper on each end to receive the gear center. The shaft is hollow, a hole 3 in. in diameter extending through from end to end. The gear center is of cast steel with a long hub which extends through the bearing brass and forms the running surface of the journal. The bore of the gear is tapered throughout its length and fits the taper on the end of the jack shaft. The gear center is pulled home to its seat on the shaft by a heavy nut on the end of the shaft,

railroad practice with overhung gearing. This width is made practicable by dividing the gear rim at its midwidth into two rings, independent flexibility being provided for each ring relative to the gear center. The gear pinions are integral and each meshes with both rings, the independent flexibility of which insures an approximately equal division of the maximum load. The pinions and gear rims were manufactured by the R. D. Nuttall Company and are of heat treated steel.

The foundation of the cab structure consists of two built-up Z-shaped girders 26 in. deep, which are spaced 6 ft. 1 $\frac{1}{2}$

in. apart. To the top of these girders is riveted a cover plate upon which the electrical apparatus is secured. At the mid-length of the cab is a built-in well 15 in. deep by about 3 ft. in width, containing the electrolyte supply from the liquid rheostat, the sides of which are supported from the center girder. To the bottom of this tank is secured the articulating device, which is of unique construction; in effect it is a link by means of which the inner bumper beams of the two truck units are held in contact, and by means of which all

detail the arrangement of the apparatus in the cab. Single-phase current at a potential of 11,000 volts is collected by a pantagraph trolley, thence following a path through an oil circuit breaker to the primary of the transformer from which it is led to the framework of the locomotive, the circuit being completed through the rails to the substation. The secondary of the transformer supplies power to the phase converter, which may be considered as a combined motor generator, transposing a portion of the power to a phase displacement of 90 deg. from that of the transformer secondary voltage. This, together with the direct supply from the secondary of the transformer, forms a two-phase source of power which is combined by means of a Scott connection to give virtually three-phase energy.

A small single-phase motor which is mounted on the shaft of the phase converter is used in starting to bring the phase converter up to synchronous speed. It is then automatically cut out and used as a direct current generator to excite a winding on the rotor of the phase converter, to obtain a power factor of unity.

A series of taps is used on the main transformer partly to regulate the drop in the secondary voltage of the phase converter through its impedance when operating under heavy loads, and the rise in voltage when regenerating; also to correct the distortion of the phase of the secondary voltage under varying loads. Electro-pneumatically operated unit switches are used to change the various taps on the transformer in such a way as to enable the change to be made from one tap to another without disconnecting the phase converter from the secondary of the transformer, or momentarily short circuiting the transformer coils.

Three-phase power is supplied to each of the four motors through a set of five electro-pneumatically operated unit switches. These motor primary switches are also used as reversing switches. One is used commonly for both forward and reverse operation, and the other four switches are used in

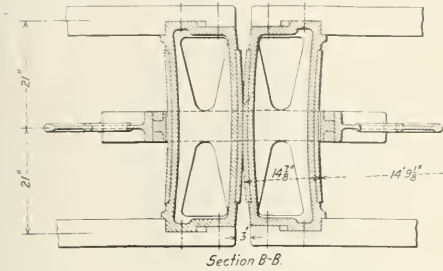

Section Plan of the Curved Bumper Castings and Articulating Link

traction stresses are transmitted from the frames of one truck unit to those of the other through the bumper beams, without imposing any stresses upon the cab structure other than those due to its own inertia.

The inner bumper beam of each truck unit is a steel casting of box section, the vertical faces of which are circular arcs with radii equal to the distances from the center of the cab center pin bearing. The two castings are thus in rolling contact with each other as the angularity of the center lines of the two trucks changes, due to track curvature. Sup-

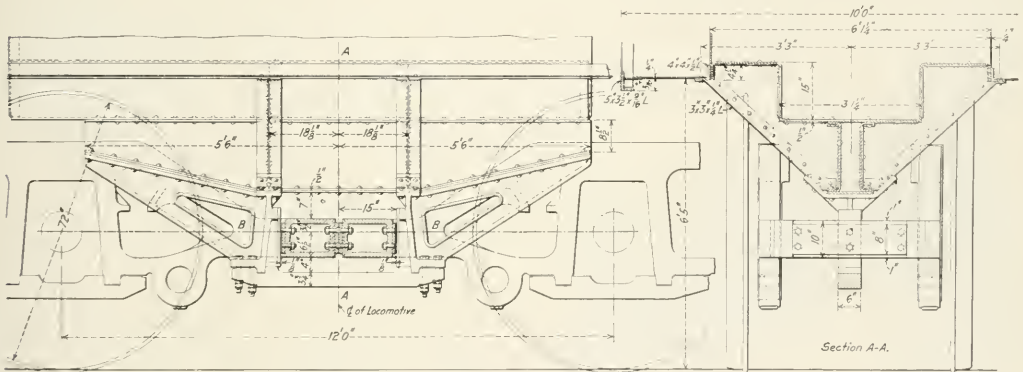

The Articulating Device—Pennsylvania Electric Locomotive

ported from the bottom of the electrolyte well by means of pressed steel channels are two steel castings, each of which forms one jaw of a longitudinal pedestal spanning the two bumper beams. This pedestal is closed by a binder generally similar to the usual type of locomotive driving box pedestal binder. The faces of the cast steel jaws are tapered and are covered by long vertical extensions on the binder to which are bolted steel wearing plates. When the locomotive is in operation the inner face of each bumper beam is in sliding contact with one of these plates. Both the inner and outer surfaces of the steel bumper beams are protected by steel wearing plates one inch thick, and held in place by countersunk bolts.

The liquid rheostats, which govern the acceleration of the pairs to interchange the connection of two of the phases for obtaining forward or reverse rotation of the motors.

The motors are arranged for two-speed combinations, or normal regenerating positions, corresponding to approximately 10 and 20 miles per hour. On the low speed, each pair of motors is connected in cascade; on the high speed, the motor primaries are connected to the three-phase supply in parallel, each secondary being connected to a regulating liquid rheostat. The control is arranged so that the change from one speed to another is made without losing more than half the accelerating or regenerating torque, this being accomplished by a progressive transition of the pairs of motors.

The liquid rheostats, which govern the acceleration of the

driving motors, are located in two separate tanks, the castings of which are built as a part of the cab frame. Each tank contains two sets of electrodes. The liquid is circulated continuously through each of the tanks by centrifugal pumps. The level of the liquid in each tank may be varied independently by means of tubular overflow valves, which are controlled by differential air engines of the Westinghouse PK type. The rheostats are located in the center of the locomotive, one pair at each end of a cooling tower compartment containing two cooling towers. A small percentage of the liquid is by-passed to the top of the cooling towers and flows over the surface of the cooling trays back into the main tank. Air is blown over the trays in a direction opposite to that of the liquid. In this way the body of the electrolyte in the main supply tank is sufficiently cooled by the expenditure of a relatively small amount of energy for pump operation, and the sacrifice of but a small quantity of electrolyte through evaporation.

When the liquid level in the rheostats has reached its maximum height, which occurs when the overflow valves occupy their uppermost position, a set of switches is automatically closed to short circuit the secondary motor winding and cut out the rheostats. A small motor generator set, the motor of which is of the three-phase induction type, provides a source of direct current for energizing the field of the phase-converter motor when it is operating as a direct-current generator to excite the phase converter motor winding. Power to operate the control circuits and marker lights is also obtained from this set.

One of the illustrations shows the master controller with the case removed. The upper handle, which is designated the "speed" handle, has three positions, one each for the 10 and 20 mile per hour combinations, and one midway between these two which is used as the transition position to enable one pair of motors to be changed over to a new combination without losing the accelerating or regenerating torque of the other pair. The center handle on the master controller controls the acceleration of the locomotive. It has three positions, marked "raise," "hold" and "lower." A movement of the handle to the "raise" position and then

each other by means of levers located in an auxiliary controller. This provides a means of equalizing the load on the different pairs of motors and of reducing the current supply to one pair, without affecting the other pair. Other levers are provided in the auxiliary controller for raising and lowering the trolley, starting and cutting out the phase converter, and operating the phase converter voltage and phase balancing switches.

Due to the inherent characteristics of the induction motor regeneration requires no extra control equipment. Manipulation of the master controller is exactly the same for re-

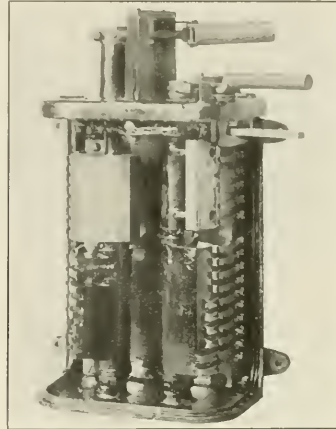

Master Controller with Case Removed

generation as it is for running. The manipulation of this type of locomotive is extremely simple for both running and braking, requiring no special knowledge other than the manipulation of the air brakes when handling heavy trains.

There are two compressor sets on the locomotive, each a four-cylinder, two-stage balanced compressor having a capacity of 150 cu. ft. These are manufactured by the Westinghouse Air Brake Company. The armature of the motor is fitted on the overhung shaft of the compressor. The motor is a Westinghouse four-pole commutator type for alternating current, and at 150 volts on each circuit develops 35 hp. continuous rating at 1,200 r. p. m. By making use of a single-phase commutator motor, the compressor set can be operated independently of the phase converter, the only other apparatus needed being the transformer. This motor has characteristics similar to a series motor and gives a high torque at starting. The compressor sets are controlled automatically by electro-pneumatic governors.

There are two sets of motor driven blowers on the locomotive. These blowers force air through ducts to the main motors, phase converter and main transformer. They are mounted one at each end of the cab. In the event of failure of one set, the air ducts and dampers are so arranged as to supply air to all the apparatus in the cab from the other set.

This feature also makes it possible to shut down one blower set while switching, and also to reduce stand-by losses. Although normally operating three-phase, the blower motor will run single-phase and act as a phase converter for the circulating pump motors. After a run, the phase converter may therefore be shut down and the blower motors will continue to run on single phase after having been brought up to speed on three-phase while the phase converter was in operation. This makes possible a further reduction in stand-by losses.

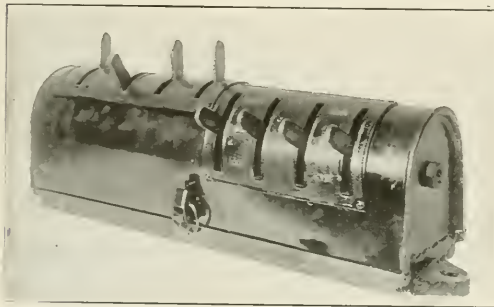

The Auxiliary Controller

back to the "hold" position gives a positive increment of rise in the liquid level of the rheostats. Moving the lever to the lower position and then back to the hold position results in a lowering of the level of the liquid in the rheostats. In this way the speed of the locomotive is controlled during either the cascade or parallel connections.

Overload protection is obtained by a current limit relay. This has the advantage of not opening the circuit, but operates first to arrest the rise of the liquid level in the rheostats and then to lower the level if the accelerating current goes beyond a certain fixed maximum value.

The liquid rheostats may be operated independently of



REINFORCING WOODEN FURNITURE CARS

At the time when the wooden car represented the standard type of construction, many railroads had built a large number of furniture cars and vehicle cars which were designed to give the greatest cubical capacity which the clearance limits would permit. In order to bring the floor to the lowest possible level, special types of bolsters were used and the sills were brought down in line with the couplers. There are many cars of this type still in use and even though their construction is such that the cost of maintenance is

for the draft gear and would be capable of withstanding severe shocks. Three types of reinforcing were considered:

(1) A complete steel underframe carrying the vertical load due to the weight of the car and the lading, as well as the buffing and pulling stresses.

(2) A steel draft member extending the full length of the car designed only to take the buffing and pulling stresses, the vertical load being carried on truss rods.

(3) Steel draft members extending from the end sill to the bolster, or a short distance beyond, and secured to the bolsters and also to the center sill.

The application of a complete underframe would have

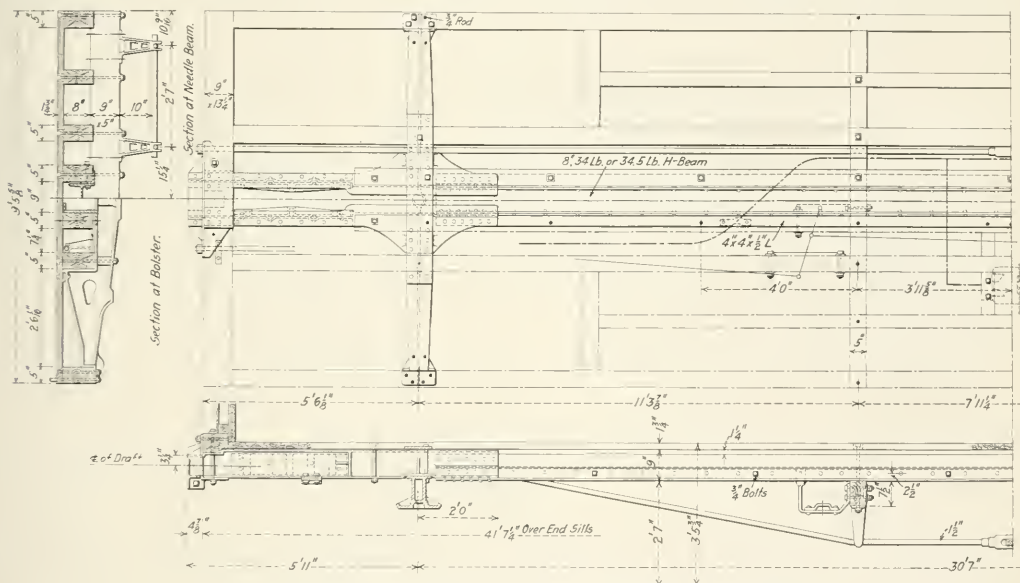

Underframe Reinforcing for Wooden Furniture Cars With Sills on the Line of Draft
As Used on the Chicago, Rock Island & Pacific

abnormally high, under the present conditions the cars must be kept in service. Many roads are therefore considering methods of reinforcing such cars to make them fit to stand hard service.

The Chicago, Rock Island & Pacific has recently applied underframe reinforcing to a large number of furniture cars of this type. Since the design presents certain problems not encountered in designing reinforcing for cars having the line of draft below the sills a description of the method used may be of interest.

It was evident that the prime requisite of the reinforcing was a construction that would provide a proper attachment

made it necessary to raise the floor level to an unusual height and the short steel draft arm would have been difficult to attach to the bolster in the proper manner. For that reason it was decided to use a design of the second type.

It was necessary to have the main member placed between the two center sills, which were 9 in. apart. The construction finally chosen consisted of an 8-in. 34-lb. H-beam, with the flanges vertical, reinforced at the lower edges by two 4-in. by 4-in. by 1/2-in. angles. The rivets joining the angles and the H-beam were countersunk in the flanges of the angles so that the assembled member would fit between the sills. The sills rest on the angles when the underframe

is in position and are fastened to it by bolts placed both vertically and horizontally.

A cast steel draft member extends from the bolster to the end of the car. It is fastened to the center member by rivets through both the vertical and horizontal flanges and



Draft Arm and Bolster Used With Girder Beam Underframe

is also riveted to the top flanges of the bolster. The drawings show clearly how well this arrangement adapts itself to the reinforcing of cars having the cut-out tie-plate type

This type of center sill member has been found to meet all requirements on cars in regular freight service and the cost of construction and application has proven much lower than other types which have been tried. A similar design has been used on cars having the sills above the line of draft, which involves the use of a draft plate below the H-beam, instead of cast steel end members, for the attachment of the draft gear. Both designs are covered by patents issued to E. G. Chenoweth, J. J. Acker and G. A. Hull, all of the Rock Island.

SIBERIAN RAILROAD ONE-THIRD EFFICIENT.—Inefficient transportation service by the Trans-Siberian Railroad is responsible for an immense congestion of traffic at Vladivostok, was the statement of S. R. Bertron, a member of the American Commission to Russia, at the second conference of the Russian-American Chamber of Commerce held recently in New York. "The Trans-Siberian Railroad is only giving about thirty per cent efficiency," Mr. Bertron said. "On the books of the line are double the number of locomotives the Pennsylvania Railroad has per mile. There are three times as many men employed on the Trans-Siberian Railroad as the Pennsylvania has, and yet the efficiency is only thirty per cent. It is expected that our government will be able to introduce a total of 75 locomotives and 1,000 cars in Russia during the present year, but this is only a small fraction

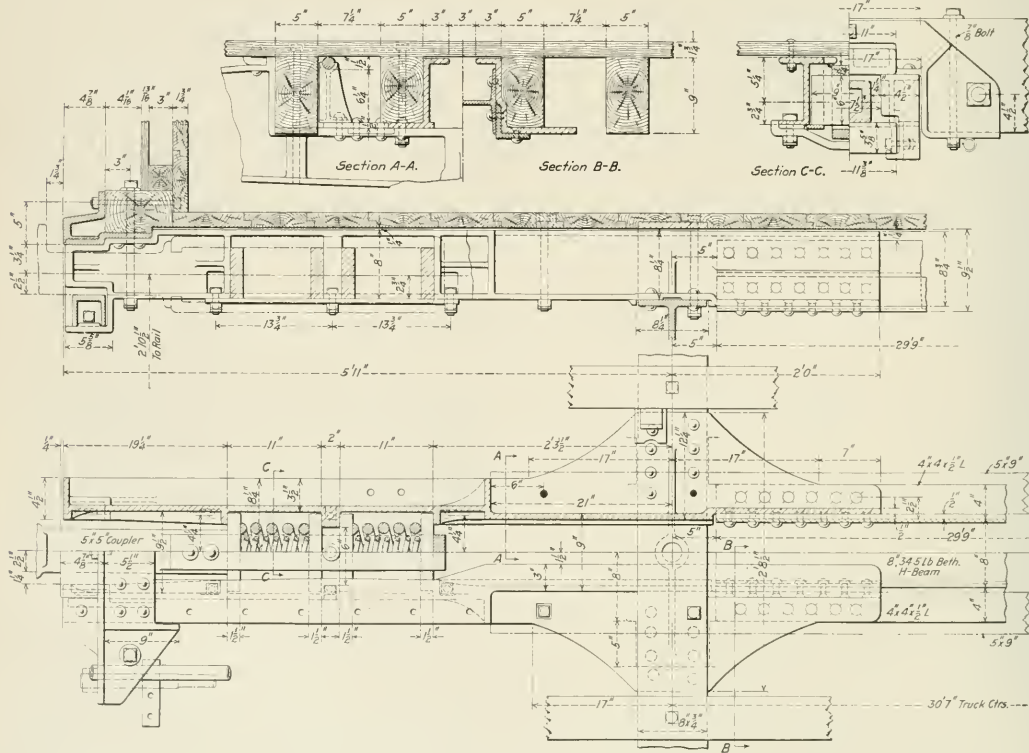

Details of Draft Arm and Bolster

of bolster and sills on the line of draft. The building of the reinforcing requires a comparatively small amount of labor and the application is very easy as the main member can be jacked directly into position between the sills.

of what Russia requires in the way of railroad equipment. [Press despatches October 16 said that the Stevens Commission had improved the situation at Vladivostok, increasing the efficiency of the railroad 25 per cent.]

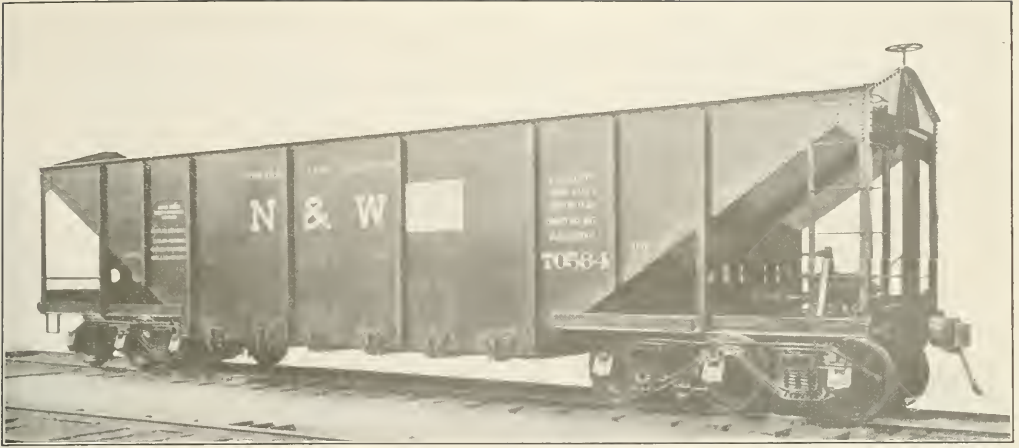

A 100-TON COAL CAR FOR THE N. & W.

Single Member H-Section Center Sills; Load Carried to Car Sides by Transverse Plate Girders

BY B. W. KADEL

THE Norfolk & Western recently built at its Roanoke Shops and put into service a 100-ton self-cleaning hopper car, of all-steel construction, using six-wheel trucks. This car, known as the class HR, has been built as a sample car the service results of which will determine the advisability

arranged in pairs extending across the car from side to side. Six pairs of doors are used, giving a door opening approximately 19 ft. 6 in. long. Each pair of doors may be dropped independently of the others.

The center sill of the car is composed of a Bethlehem

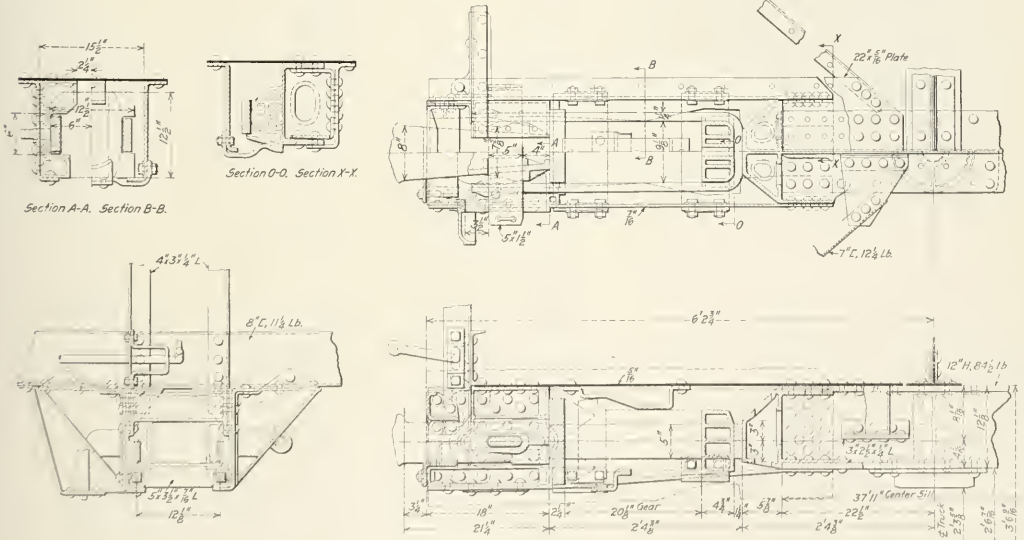

of providing larger quantities of this type for this service. The design of the car follows previous designs of Norfolk & Western hopper-bottom cars in that the drop doors are

12-in., 84½-lb. H-section and extends slightly beyond the bolsters at each end of the car, where it is milled off to exact length and a true surface. Pressed-steel draft sills are

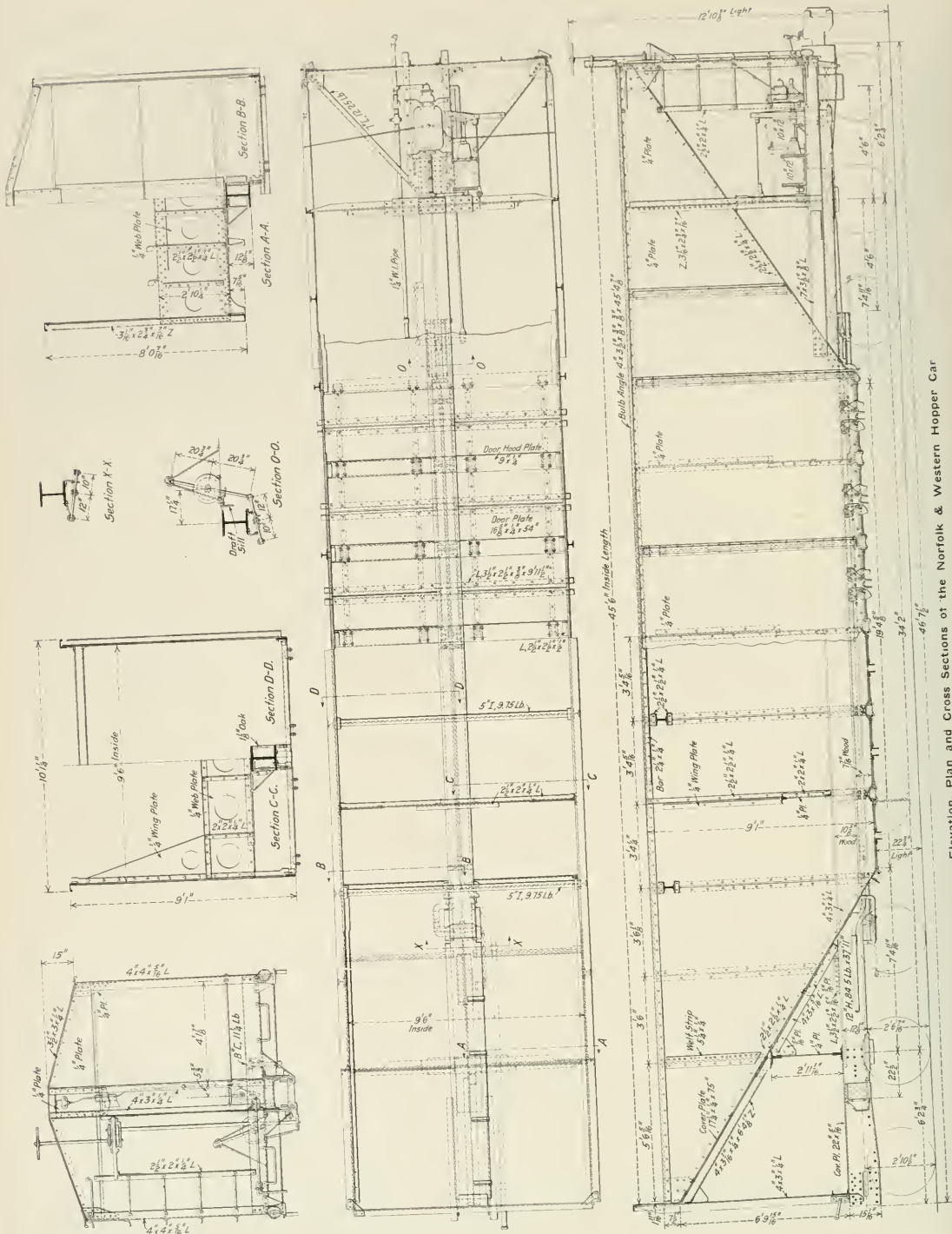

Elevation, Plan and Cross Sections of the Norfolk & Western Hopper Car

splined to the center sill by means of a steel back-stop casting and top and bottom cover plates. The draft gear stops against this casting in buffing and the back stop casting is arranged to directly abut the end metal of the H-section, so that all the buffing load is delivered to the center sill without depending on rivets for this purpose.

The draft sills are made of 7/16-in. steel plates, flanged, and are tapered from 12-in. in depth at the rear to 15-in. in

connecting the coupler to the yoke, and it will be seen from the draft gear layout that an exceptionally large bearing surface has been provided between the key and the yoke and between the key and the coupler. The key has been relieved of all bending stresses by allowing the outward extensions of the back key bearing on the coupler to overlap the inside extensions of the front yoke bearing.

The car is equipped with Sessions-type "K" friction draft gear, and the coupler used is the M. C. B. 6-in. by 8-in., type "D," with a shank 21 1/2-in. long. For a carrier iron a 5-in. by 3 1/2-in. by 7 10-in. angle is used. This is supported upon flanges cast from the cheek plates and is held in place by two bolts through the vertical flange of the angle. The weight of the coupler is carried directly on the cheek plate shelves, upon which rests the horizontal flange of the carrier, and the bolts merely keep it in place. The coupler limit stops are formed by turning up the horizontal leg of the angle iron at the ends. By this arrangement removing the

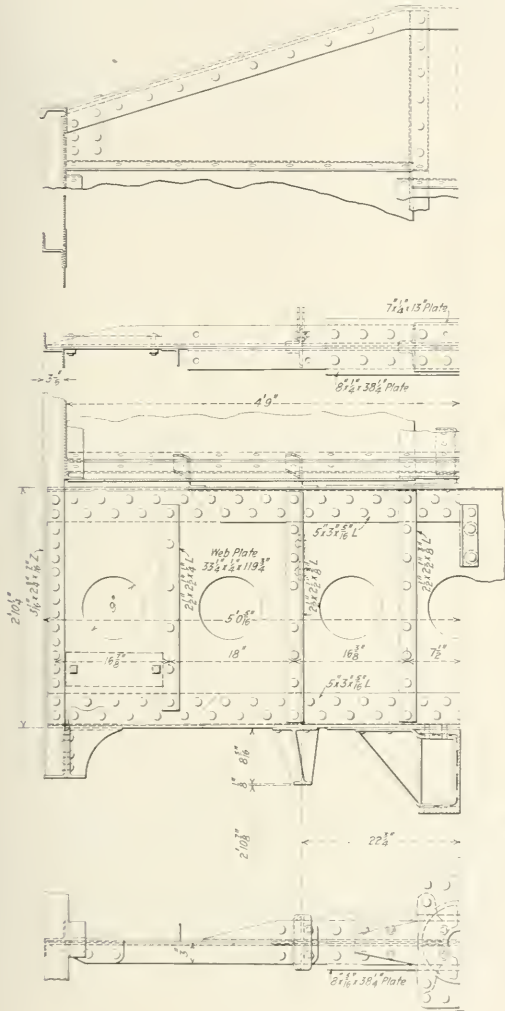

Details of the Bolster and Elevation of the Hopper End of the Norfolk & Western Hopper Car

depth at the front end and are spaced 15 1/2 in. between the webs.

The Farlow one-key draft attachments are used. The cheek plates are riveted to the inside faces of the draft sills and form the stops for the front follower in pulling. The yoke is laid horizontally and is continuous. The buffing load is transmitted through the rear end of the yoke directly to the back stop casting. A 1 1/2-in. by 5-in. key is used for

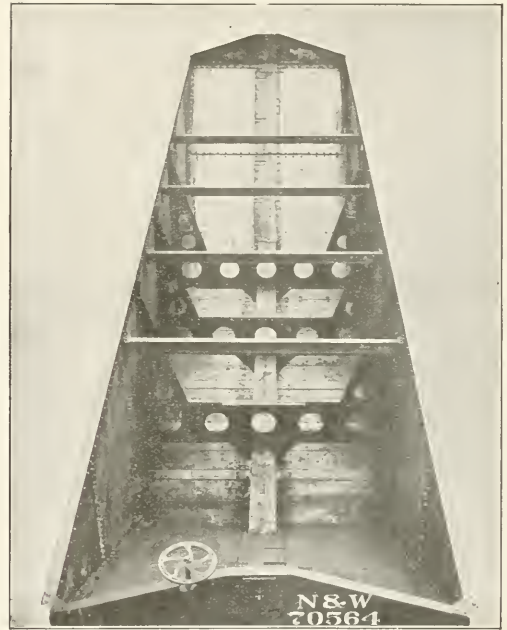

A View of the Interior of the Car Body

carrier iron also removes the limit stops and the yoke can then be drawn out of the end of the coupler pocket.

The car is built up of plates and structural shapes, the minimum plate thickness being 1/4 in. Three diaphragms or transverse plate girders are placed across the car to support the center sill and transfer the weight of the lading to the sides of the car. At these diaphragms are placed inside side stakes and wing plates are also carried up from the diaphragms to a point near the top coping angle to stiffen the sides of the car. Midway between the diaphragms are placed outside side stakes of Carnegie M-24 cross-tie section. The splines in the side sheets are made at these stakes. Cross-ties of 5-in. I-beam section are placed across the coal-space near the top of the car in the same transverse planes as the side stakes. The side stakes support the car against the cradle of the car dumper, over which the car must be handled at times.

The top coping angle is a Carnegie bull angle of 4 in. by

3 1/2-in. by 3/8-in. section, which extends the full length of the car. For a bottom flange member a 5-in. by 5/8-in. flat bar is used; this member is in tension only. Where the load requires it, near the center of the car, this bar is reinforced with 5-in. by 5/16-in. flat bar.

The slope of the hopper is 33 deg. and between each pair of doors is a small hood to make the car entirely self-cleaning. These hoods are likewise constructed to have slope angles of 33 deg.

The ends of the car are formed into plate girders and are carried up to form end coal boards, thus encouraging filling out the ends of the car at the tipples and insuring a good heap. The outer ends of the draft sills are supported from these end plate girders by two 4-in. by 3-in. by 1/4-in. vertical angles. Care has been taken to properly attach the end plates to the corners of the car so that the downward forces from the coupler may be properly transmitted to the sides of the car.

The end sill is an 8-in., 11 1/4-lb. channel, which is framed

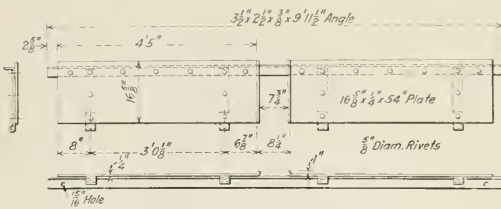

Construction of the Drop Doors

at the corners to 7-in. by 3 1/2-in. by 3/8-in. angles forming short side sills under the slope of the hopper.

Diagonal braces of 7-in., 12-lb. channels are used, extending from the corners of the car to the back end of the draft sill corner plates, to which they are riveted.

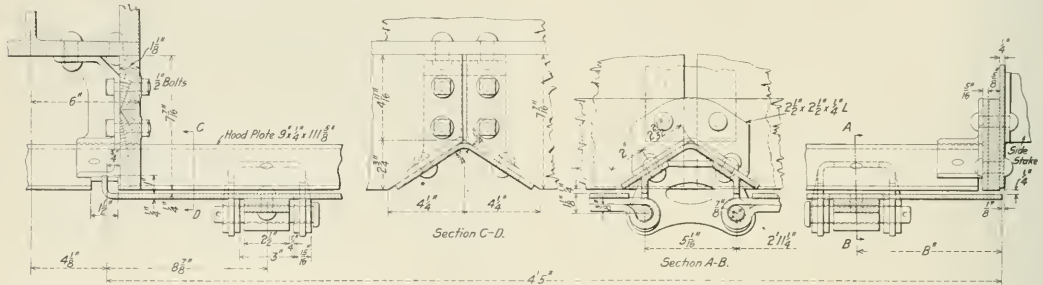

Cross Sections Showing the Details of the Doors for the Norfolk & Western 100-Ton Coal Car With Their Attachments to the Car

At each corner is a push-pole pocket which also includes a jacking pad beneath the corner construction. The design of the corner has been so worked out that, either in poling or jacking, the end metal of the structural sections come into bearing, and the load is transmitted to them without depending upon the rivets. Special provision has been made at the top of the 4-in. by 4-in. by 5/16-in. corner angles to take care of the loads at this point when the car is stooled under the corner jacking pads.

The bolsters consist of plate girders which are located above the center sill and beneath the hopper chute. These are constructed of 1/4-in. web plates with top and bottom flange angles on both sides of the plate, and cover plates. The angles on the inside of the web plate and the cover plates are stopped off where the reduction in stress permits. For a side stake at

each end of the bolster a 3 1/16-in. by 2 3/4-in. by 7/16-in. Z-bar is used. The web plate of the bolster is carried out and riveted directly to the web of this Z-bar, thus avoiding a duplication of rivets and framing angles at this point. Jacking pads are provided at the ends of each bolster so that the car may be jacked at one point and stooled at the other.

The doors are supported by a simple door hook arrangement manufactured by the Wine Railway Appliance Company. No winding shafts are used, the doors being raised by

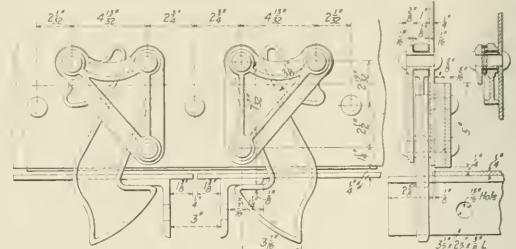

The Drop Door Latch and Lock

hand. This arrangement is shown in detail in one of the drawings.

The center sill where it passes through the coal space of the car is faced between the flanges with 1 1/8-in. oak boards so as to present smooth sides for the coal when dumping from the bottom or in the dumping machine.

The car is equipped with the Lewis articulated six-wheel trucks as manufactured by the American Steel Foundries. It is fitted with Westinghouse 10-in. by 12-in. air brake equipment. The hand brake is of the customary pattern, except that the brake staff is made in two pieces with reduction gears placed between them in order to give the necessary

braking power without having an excessive amount of chain to wrap.

During the several months that this car has now been in service its performance has been entirely satisfactory. The general dimensions are as follows:

Inside length	45 ft. 6 in.
Coupled length	49 ft. 2 in.
Length over striking faces	46 ft. 7 1/2 in.
Truck centers	34 ft. 2 in.
Inside width	9 ft. 6 in.
Extreme width	10 ft. 1 1/4 in.
Height to top of sides	11 ft.
Extreme height	12 ft. 10 3/4 in.
Volume, level fill	2,828 cu. ft.
Volume, 30-deg. heap	552 cu. ft.
Volume, total	3,380 cu. ft.
Capacity	100 tons
Light weight	60,000 lb.

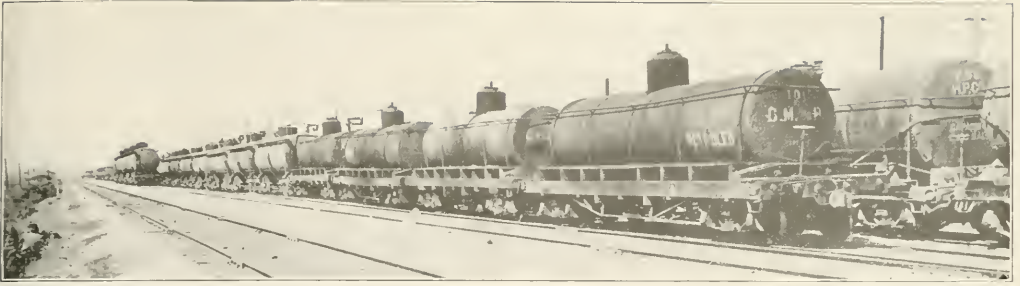

Copyright by Underwood & Underwood, N. Y.

THE TANK CAR IN INTERCHANGE

Characteristics of the Different Types Under M. C. B. Specifications; Important Points for Car Inspectors

BY E. S. WAY

Superintendent of Equipment, General American Tank Car Corporation

IN 1916 the M. C. B. Tank Car Committee went into the question of the construction of tank cars more thoroughly than ever before and new specifications were adopted. In addition definite classifications were given as follows:

Class I.—Tank cars for general service, with wooden or steel underframes, or without underframes, built prior to 1903.

Provision was also made limiting the use after January 1, 1918, of Classes I and II cars, where the tanks have been tested to only 40 lb. per sq. in., to the transportation of products whose vapor pressure at a temperature of 100 deg. F. does not exceed 10 lb. per sq. in., and which do not give off inflammable vapors at or below a temperature of 80 deg. F. In addition,

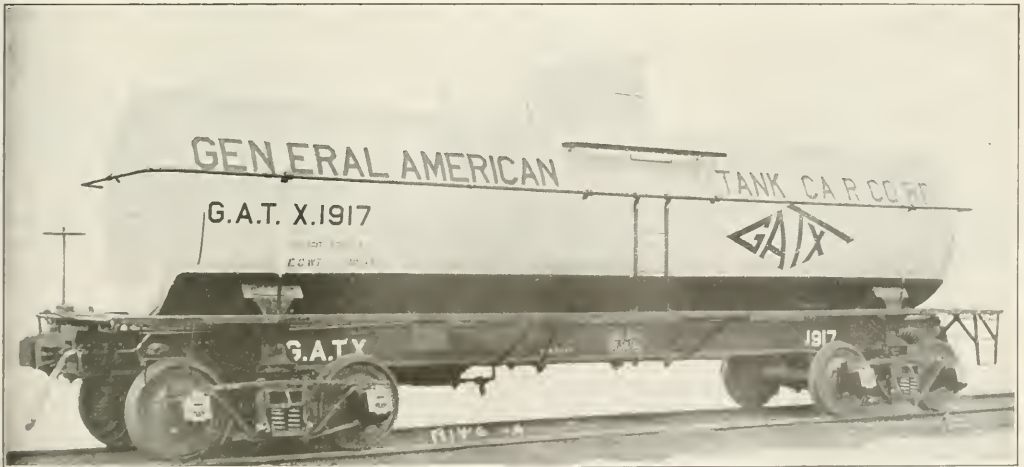

Class III—Tank Car Built According to MCB 1917 Specifications

Class II.—Tank cars for general service, with steel underframes or without underframes, built between 1903 and May 1, 1917.

Class III.—Tank cars for general service built after May 1, 1917.

Class IV.—Tank cars for the transportation of volatile inflammable products whose vapor pressure at a temperature of 100 deg. F. exceeds 10 lb. per sq. in., built after May 1, 1917.

In 1917 some minor changes were made in the specifica-

tions for Classes III and IV. Provision was also made limiting the use after January 1, 1918, of Classes I and II cars, where the tanks have been tested to only 40 lb. per sq. in., to the transportation of products whose vapor pressure at a temperature of 100 deg. F. does not exceed 10 lb. per sq. in., and which do not give off inflammable vapors at or below a temperature of 80 deg. F. In addition,

detailed specifications were adopted under the following head:

Class V.—Insulated tank cars of especially heavy construction, built after January 1, 1918, for the transportation of liquid products whose properties are such as to involve danger of loss of life in the event of any leakage or rupture of the tank. Liquid products of this description whose shipment has been authorized are: chlorine and sulphur dioxide.

The third paragraph of the Preface of the M. C. B. Code of Interchange Rules reads:

"Inspection of freight cars for interchange and method of

*From a paper presented before the Car Foremen's Association of Chicago.

loading will be in accordance with this Code or Rules, the Specifications for Tank Cars, and the Loading Rules, issued by this Association."

Thus it will be seen that the tank car specifications practically become a part of the interchange rules, and it therefore devolves upon the car inspector to utilize his leisure moments in familiarizing himself with these requirements.

To assist those not already familiar with the requirements, to differentiate between the different classes of cars, the following points will probably be of assistance:

The tank car specifications define a tank car as follows:

"Any car to which one or more metal tanks, used for the transportation of liquids or compressed gases, are permanently attached.

"Note—These specifications do not apply to cars having wooden or glass lined tanks; nor to tanks enclosed in box or other house cars.

"Sec. 23, 'Test of tanks, does not apply to cars specially designed for the transportation of solids, such as lime nitrogen.

"To indicate to inspectors and others handling cars with wooden or glass lined tanks or cars specially designed for the transportation of solids that such cars do not come under

words, it must be secured to the underframe by some means other than by the use of head blocks.

(c) Safety appliances must conform to the arrangements shown in Fig. No. 7 of the specifications for tank cars revised 1917, the principal points of which are that the running boards must have a maximum height not to exceed 50 in. above the top of the rail, and the tank must be provided with dome ladder, dome platform and hand holds.

The Class IV car is constructed practically the same as the Class III car, the idea being to make it possible to convert the Class III into a Class IV car if desired. The principal difference between the two is that the Class IV car must be insulated by the use of insulating materials and, in addition, the entire tank covered by a metal jacket. Further, these tanks must be tested with cold water at a pressure of not less than 75 lb. per sq. in. and so stenciled, although in some instances they may be found to be stenciled as tested at 100 lb., which was required prior to May 1, 1917.

The Class V car is insulated and in general appearance resembles the Class IV car. It can be distinguished, however, from the latter by the test stenciling, which will show a pressure of 300 lb. per sq. in. Further, the safety valve and other dome fixtures, which are especially designed, are en-

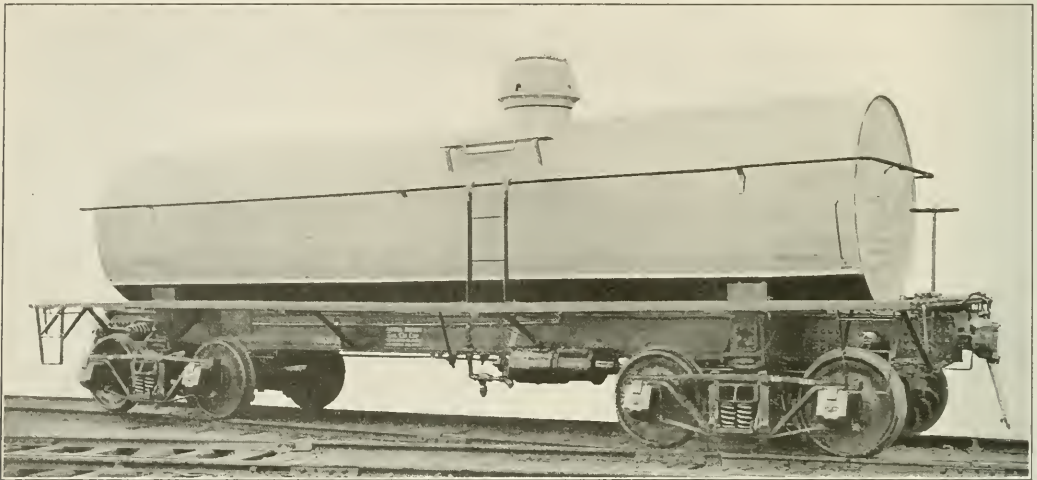

Class V—Insulated Tank Car for the Transportation of Liquefied Chlorine

the provisions on the tank car specifications, the words 'Wooden-lined Tank—Pressure Test not Required,' or 'For Solids Only—Pressure Test not Required,' as the case may be, should be stenciled on the tank in place of the record of test of tank."

Generally speaking, the "Date Built" as stenciled on both the tank and underframe will serve as a guide to inspectors.

The majority of wooden underframe cars will be found to be Class I cars and built prior to 1903, although there were some steel underframe tank cars built prior to this date which would be subject to Class I requirements.

All tanks having single riveted seams and mounted on steel underframes or without underframes, built subsequent to 1903, will be subject to Class II specifications. However, there were tanks built with double-riveted seams prior to May 1, 1917, which would likewise be Class II cars.

The outstanding features of Class III tank cars are:

(a) The tanks are double riveted throughout with the exception of the dome head seam, which may be single riveted.

(b) Tank secured to underframe by anchorage at the bolsters or at some point or points between bolsters. In other

tirely covered by a metal casing, the object of this being to prevent damage to the valves and consequent escape of the contents in case of wreck or accident. This latter feature is very important by reason of the deadly fumes given off by either chlorine or sulphur dioxide.

Care will of course have to be exercised to distinguish the Class IV and Class V cars, both of which are insulated, from other insulated cars that are used for the transportation of water, wine, hot pitch, etc., the test pressure of which will not exceed 60 lb. per sq. in.

The specifications as revised in 1916 and 1917 also refer to the tank car that is rebuilt either by the application of a new tank or a new underframe. Such cars, if rebuilt after May 1, 1917, must have the tanks secured to the underframe by some means other than headblocks and must have the safety appliances standardized to meet the requirements for new cars. There are of course additional requirements, but the two just referred to are perhaps the most prominent.

Let us now consider briefly the various interchange rules relating specifically to tank cars:

Rule 2, Section B, second paragraph—"Cars containing

inflammable liquid which is leaking must be repaired or transferred without any unnecessary movement or at nearest available point."

The proper application of this provision necessitates inspectors being familiar with the facilities, at or nearest to their respective districts, for either repairing such car or for the transfer of lading, as the case may require.

Rule 3, Section E—"Tank cars (empty or loaded) will not be accepted in interchange unless they comply with the M. C. B. Tank Car Specifications."

This is a rule which, like some other rules in the interchange code, if applied literally and without the exercise of good judgment, will work hardships on the delivering line as well as on the shipper. A thorough knowledge of the specifications is therefore necessary in order that the purpose of this rule may be intelligently served. To be more explicit, there may be certain conditions found on a tank car that do not fully comply with the detailed requirements, but which would not interfere with the safe movement of the car or contents. The rejection of a tank car because of such conditions would in most cases serve no good purpose, but on the contrary may, from a carrier's viewpoint, result in unnecessary and undesirable movements, as well as delays that would be serious and expensive to the car owner or shipper. Obviously, the proper procedure in such cases would be to report the objectionable features to the car owner who could have them corrected at the first opportunity.

Rule 3, Section (g)—regarding stenciling date built on cars provides that in the case of tank cars the body and tank should bear distinctive dates unless constructed at the same time. This rule became necessary on account of the large numbers of wooden underframe tank cars being rebuilt with steel underframes, the stenciling of the date built on both tank and underframe serving as a basis for depreciating the

value of tank and underframe separately in cases of destroyed cars and also serving as a guide to inspectors in checking up rebuilt tank cars with the specifications for the reason that tank cars rebuilt after May 1, 1917, are subject to 1917 revised specifications.

On pages 17, 19 and 21 of the interchange code will be found a number of interpretations relating to tank cars. These interpretations are self-explanatory. There is one point, however, which it might be well to mention, viz., the requirements relating to test of tanks and safety valves. There appears to be some misunderstanding on the part of the railroads as to their responsibility in the matter of testing tanks and safety valves where the test periods expire while cars are in their possession. In a number of such instances, certain railroads have taken the question up with the car owners asking disposition of the cars whereas they should make the necessary tests at the nearest point where they have facilities for handling this work, which they are obliged to do under the M. C. B. rules. In other words, these tests should be treated the same as any ordinary repairs to freight cars.

Rule No. 9, last paragraph, states: "When tank or safety valve of tank cars is tested in accordance with the M. C. B. Specifications for Tank Cars, the certificate of test, as required by the Interstate Commerce Commission Regulations, must accompany the billing repair card."

The certificate of test is a form prescribed by the Bureau of Explosives, and it is very important that it be properly executed as required. When tests are made by parties other than the owners, the certificate of test should be made out in triplicate, one copy to be retained and two sent to car owner.

There are a number of rules contained in the Bureau of Explosives Pamphlet No. 9 which should be carefully studied in connection with this subject.

C. M. & ST. P. FIFTY-TON GONDOLAS

Steel Center Sill Designed to Resist Buffing Stresses Only; The Load Is Supported by Six 1½ in. Truss Rods

THE Chicago, Milwaukee & St. Paul is now building at its shops at Milwaukee and Taccma 1,500 50-ton gondola cars. A composite design has been adopted for this equipment, principally on account of the difficulty of securing prompt deliveries of steel at this time. Although heavy

In the design of the car the principal aim was to use wood as extensively as possible and yet provide a car that would give good service and insure economy from the standpoint of maintenance. With this thought in view, a heavy steel center sill has been provided to take care of the buffing and pulling stresses, while the weight of the body and lading is carried on wooden sills and truss rods. The length of the car over

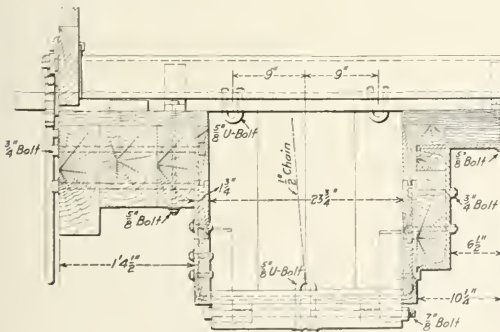

Cross Section of Car at Hopper



Hopper Car for the C. M. & St. P.

sills are used, the ratio of light weight to capacity has been kept reasonably low, the average light weight being 42,100 lb. It will be seen, therefore, that the ratio of the revenue load to the maximum total weight of these cars is 72.3 per cent.

the end sills is 42 ft., the maximum width, 10 ft. 1½ in., and the maximum height from the top of the rail, 8 ft. 6¾ in. The body of the car is 39 ft. 11½ in. long, 8 ft. 7 in. wide, and 4 ft. 3¾ in. deep. The cubical capacity of the car, with the load heaped 2 ft. above the sides, is 2,000 cu. ft.

In the construction of the car body the metal parts have

HELICAL SPRING CALCULATION

BY ALBERT H. LAKE, JR.

been confined almost wholly to the center sill members. Two channels, of 15-in. 37-lb. section, extend from end to end of the car and are reinforced for the entire length by 1 3/4-in. by 20-in. cover plate. Under the center sills two truss rods, 1 1/2 in. in diameter with 1 3/4 in. upset ends are provided to carry the weight of the lading. The body bolsters are built up of rolled sections and filler castings. The tension member, which passes through the neutral axis of the center sills, is 3 1/4 in. by 12 in., while the compression member is 1 1/8 in. by 12 in.

The sides of the car body are supported by two wooden sills, the outer 5 in. by 13 1/2 in., and the inner 4 1/2 in. by 10 in. These sills are also reinforced with two 1 1/2-in. truss rods.

The four hoppers, 23 3/4 in. wide and 8 ft. long are placed between the center sills and side sills, the centers being 12 ft. 3 in. from the ends of the car. Short intermediate sills extend from the ends of the car to the hoppers and between the hoppers, being supported by the end sills, body bolsters

Where the end for a helical compression spring as shown in Fig. 1 is not formed by grinding, but is forged and drawn out, the bar that the spring is made from is some shorter than the bar in the finished spring.

Fig. 2 shows an improper form of end for a compression spring. The end of the tapered part should not come in contact with the adjacent coil as that would make this coil non-effective from the point of contact to where the taper starts, which would be one-quarter of a coil.

Fig. 3 shows a correctly tapered end before coiling.

In the following formulas:

- d = diameter of bar from which spring is made
- D = mean diameter of coil
- h = solid height of spring
- L = blunt length or length that bar is cut from stock
- L₁ = length of tapered part on each end of bar
- L₂ = total length after tapering
- N₁ = number of effective coils
- N₂ = total number of coils

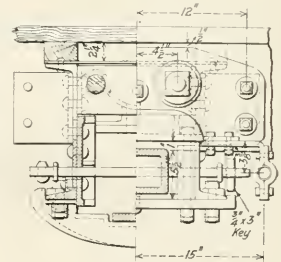
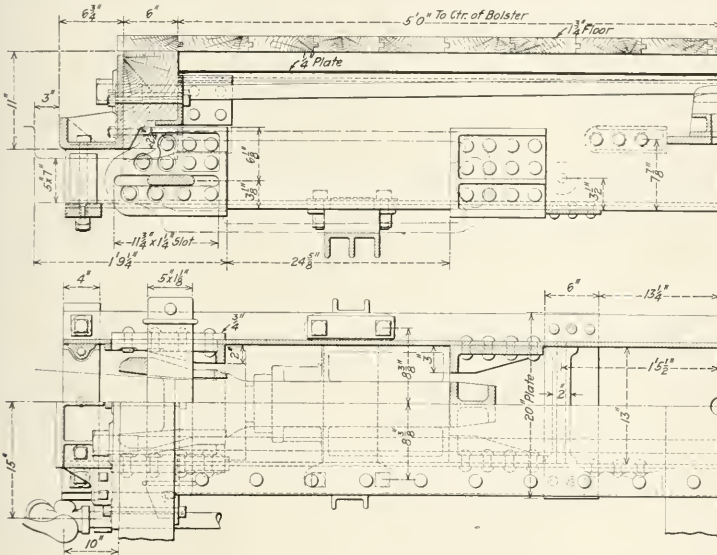

Details of Center Sills and Draft Attachments

and needle beams. The side stakes are 3 3/8 in. by 5 1/2 in. Every third pair of stakes is tied together with a 3/4 in. rod extending under the center sill. The sides of the car body are 2 1/2 in. thick and the floor is 1 1/2 in. thick.

The hoppers are reinforced on the sides and the ends by metal strips bolted on the inner side to the center sill channel and on the outer side to the two side sills. The dumping mechanism consists of 2 1/4-in. shafts extending across the car above the deck, with chains to raise the hopper doors. A 5-in. by 5-in. angle iron is placed over each shaft to protect it from the lading.

The details of construction of the hoppers are shown in one of the illustrations.

On account of the difficulty of securing clearance between the brake wheel and the end of the car, special types of ratchet brakes have been applied.

Among the specialties used on these cars are Bettendorf truck side frames, Bettendorf and Buckeye cast steel truck bolsters, Barber lateral rollers, Ajax brake beams, Major couplers with Buckeye cast steel yokes and the Miner friction draft gears.

The length of the tapered part on each end should be three-fourths of one coil or $L_1 = \frac{3 \times D \times 3.1416}{4}$

The thickness A, Figs. 1 and 3, at the end of the tapered part should be equal to one-fourth of the diameter of the bar or $\frac{d}{4}$, as this will bring all of the coils in contact at the same time when the spring is compressed solid.

The familiar formula $N = \frac{h}{d}$ where N = the number of coils, can only be used to find L, as it gives neither the total number or effective number of coils.

The length of bar required, that is, the blunt length to be ordered or cut from stock, is found by the formula

$$L = \frac{3.1416 \times D \times h}{d}$$

This is true only when the tapered part is made as shown

in Fig. 3 where L = blunt length, L_1 length of tapered part, X = one-half of one coil, y = one-fourth of one coil, and

$$A = \frac{d}{4}$$

The number of effective coils is found by the formula

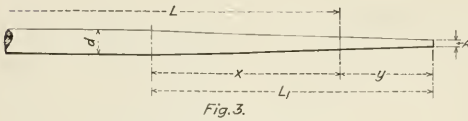
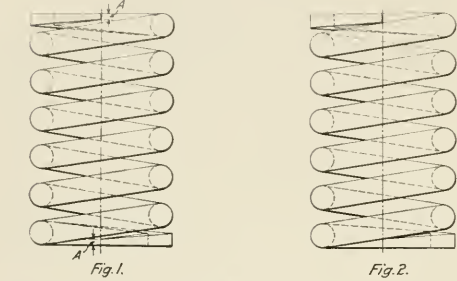

Taper End Helical Springs

$$N_1 = \frac{h}{d} - 1 \text{ and the total number of coils by the formula}$$

$$N_2 = \frac{h}{d} + 0.5$$

of the following dimensions: $d = 1$ in., $D = 5$ in., $h = 6.5$ in., then:

$$L_1 = \frac{3.1416 \times 5 \text{ in.} \times 0.5 \text{ in.}}{1 \text{ in.}} = 102.1 \text{ in.}$$

$$L_2 = \frac{3 \times 5 \times 3.1416}{4} = \frac{47.124}{4} = 11.78 \text{ in.}$$

$$L_2 = \frac{3.1416 \times 5 \times 6.5}{1} + \frac{3.1416 \times 5}{2} = 102.1 + \frac{15.708}{2} = 109.95 \text{ in.}$$

$$N_1 = \frac{6.5}{1} - 1 = 5.5$$

$$N_2 = \frac{6.5}{1} + 0.5 = 7$$

VACUUM CLEANER

BY HOWARD W. STULL
Machine Shop Foreman, Philadelphia, & Reading, Reading, Pa.

A vacuum cleaner is shown in the drawing which was developed on the Philadelphia & Reading. It has been in successful use on that road for about a year in cleaning passenger cars and offices at points where compressed air is available. The device is intended to be left on the platforms of cars and in the hall outside of office doors while in operation, a 50-ft. length of four-ply water hose being used to make this possible.

One of the difficulties which is experienced with many

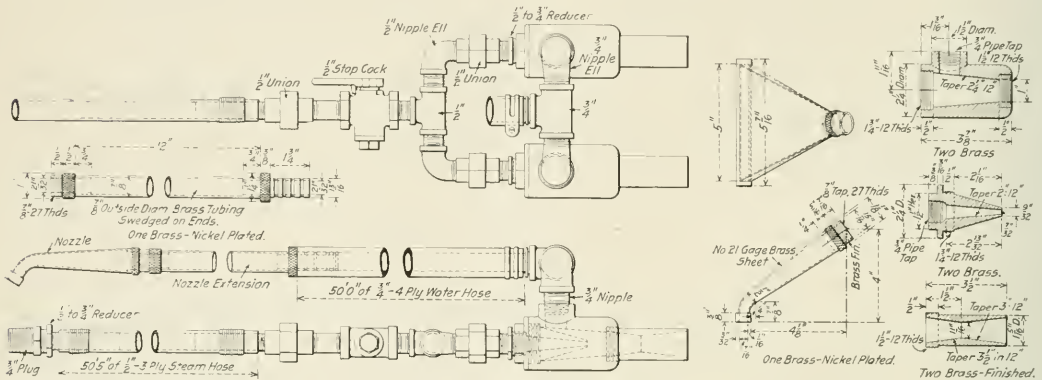

A Simple Shop-Made Vacuum Cleaner

On drawings of helical springs the length of bar is generally given thus:

One Bar 1 3/16 in. diameter, 73 3/4 in. long, tapered to 80 3/8 in.

The 73 3/4 in. would be found by the formula:

$$L = \frac{3.1416 \times D \times h}{d}$$

And the 80 3/8 in. by the formula:

$$L_2 = \frac{3.1416 \times D \times h}{d} + \frac{3.1416 \times D}{2}$$

To illustrate the use of the above formulas assume a spring

vacuum cleaners is that they become stopped up, especially in very damp weather, and are not easily cleaned out. It will be noticed that with this cleaner the vacuum chambers may be cleaned out very readily by removing the combining nozzles and turning on the compressed air. The vacuum gage registers about 18 in. when using the cleaner with air pressure at 100 lb. per square inch. Of course, a higher vacuum may be produced if higher air pressure is available.

Little need be said relative to the construction of the device, as the drawing clearly shows all the details. As developed on the Philadelphia & Reading, the parts are made of Brass, but there is no logical reason why cast iron can not be used if desired.

SHOP PRACTICE

PORTABLE ALLIGATOR SHEARS

BY E. S. NORTON

The portable alligator shears illustrated were made at Conneaut, Ohio, by the New York, Chicago & St. Louis for cutting up scrap iron rods, and they have proved a valuable asset to the reclamation and scrap handling department. Power is readily obtained from the shop air line and as the shears are portable they may be placed wherever is most convenient, thus reducing to a minimum the cost of handling tangled masses of scrap iron rods and bars. Eighty pounds air pressure will give sufficient shearing power to cut 1½-in. round iron or iron bars up to 1-in. by 3-in.

The machine is constructed entirely of second hand material and consists, as indicated, of two 12-in. brake cylinders bolted to a framework of 13-in. channel iron which is mounted on a portable truck. The shears are of the general dimensions shown, the lower shear being stationary and bolted firmly to the inside of the channel its entire length. The movable shear is supported by a 3-in. fulcrum pin at A, and from B is connected to the brake cylinders by a 2-in. rod and cross equalizer. It will be noted that ball joint washers are used in the construction and there is enough lateral play to prevent the rod bending should one piston start ahead of the other.

When the brake cylinder pistons are forced up by the air pressure, the motion is transmitted through connecting levers and operates the shear blades. The supply of air to the brake

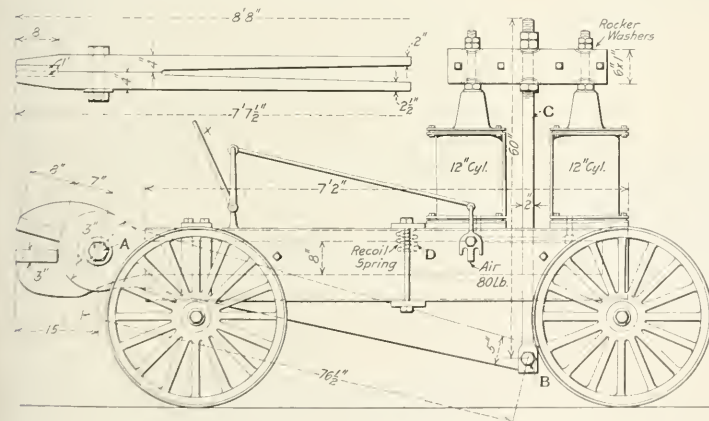

Portable Alligator Shears for Cutting Scrap

cylinders is controlled by a three-way valve, which in turn is operated by a handle X near the shears. In this way one man can hold on light work with one hand and operate the shears at the same time with the other. The recoil spring D is to take up vibration and shock due to the upward

plunge of the pistons after the bar has been cut through. This machine has been in successful operation for some time.

A HANDY SWIVEL "V" BLOCK

In making milling cutters or reamers with inserted teeth, considerable difficulty is often experienced in holding the work while performing operations on shapers or drill presses.

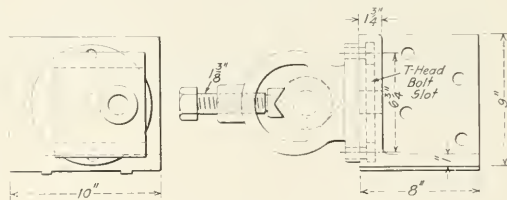

V-Block for Special Drill Press or Shaper Work.

To facilitate work of this sort the West Burlington shops of the Chicago, Burlington & Quincy have made a special chuck which has also been found handy for doing many other jobs.

The chuck consists of a V-block large enough to take

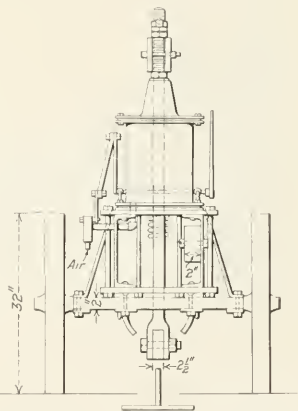

pieces not more than 5 in. in diameter, with a screw for holding the work. The base of the V-block fits on an angle plate which is held in place by two T-head bolts in a circular slot. When in use the angle plate is bolted to the table of the machine on which the chuck is to be used.

MICROSCOPIC STUDY OF WELDED TIRES

BY S. W. MILLER

SOME time ago, the writer's attention was drawn to the fact that it was rather common practice to fill up slid flat spots on steel tires, and to make other repairs of a similar nature, by fusion welding methods, with a view to saving the metal of the tire which would have to be turned off to remove the flat spot. This practice was started because of the apparent resultant saving, not only in tire metal, but in repair cost and time, and if the method was successful it is obvious that this saving would be very great. But there

the room temperature it was marked off in sections beginning at the center of the weld, and extending beyond its end, as shown in Figs. 2 and 3. The sections were then cut off in a power hacksaw, polished, etched and photographed.

The etching showed that it was advisable to use three test pieces per section, and these were marked off, as shown on

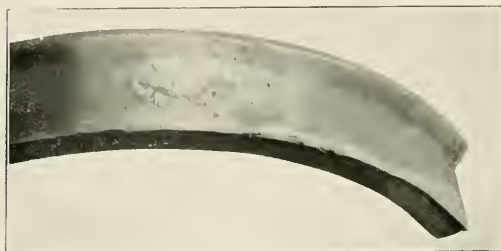

Fig. 1—Section of Tire Showing Welded Flat Spot.

was the possibility, and a very strong one, that such a method was in reality unsatisfactory, and even dangerous, because of the changes produced in the structure of the metal by the heat, which would change its physical properties.

As the writer knew of no tests showing what had occurred during and after the welding, he decided to make some for his own information, and the results so strongly confirmed his beliefs that they are here presented in the hope that those who may take the trouble to study the matter will see the danger of the practice. Fusion welding processes are capable of wide application, but they are not a panacea and should be used with discretion.

For the purpose of test a scrap tire from a switch engine, shown in Figs. 1 and 2, was selected and the physical and chemical properties were obtained from the manufacturers. A comparison of these properties with the A. S. T. M. specifications for standard switch engine tires is made in the accompanying table and shows that the tire selected for test met all the requirements.

The weld was made by the oxy-acetylene process, about $\frac{1}{4}$ in. of metal being added at the thickest part of the weld, and low carbon steel wire of about .08 per cent carbon content was used as a filler. After allowing the tire to cool to

	Tire to be tested	A. S. T. M. specifications
Tensile strength.....	141,200 lb.	125,000 lb.
Elongation in 2 in....	11.1 per cent	8.0 per cent
Reduction of area.....	29.1 per cent	12.0 per cent
Carbon content.....	.765 per cent	.70-.85 per cent
Manganese707 per cent	Not over .75 per cent
Phosphorus047 per cent	Not over .05 per cent
Sulphur037 per cent	Not over .05 per cent
Silicon239 per cent	.15-.35 per cent

the lines on Fig. 4, which also shows the location, marking and hardness numbers obtained from Brinell and scleroscope tests.

These test pieces were marked to include, as far as could



Fig. 2—Tire Marked off in Sections.

be seen, the same structure as shown by the coloration produced by the etching in Fig. 5, it being desired to obtain a number of test pieces from each type of zone. For example, it was thought that test pieces 4, 7, 10, 13 and 15 (Fig. 3) would probably give nearly the same results, but quite different from test pieces 6, 9, 12 and 14, which were in an entirely different zone, as shown by the etching.

The numbers in Fig. 2 were the ones for the original test pieces, and may be partly seen in Fig. 3, stamped into the sections. The white numbers in Fig. 4 are the ones later decided on, and which are used throughout this article.

It appears from Fig. 5 that the changes of structure indi-

cated may be divided into four principal zones. These are zone *A*, the added material; zone *B*, the darkest one which has the finest grain, having been heated above the critical range and rapidly cooled by conduction of the heat to the rest of the tire; zone *C*, the lightest one which has been heated

It is important to remember that, while the zones appear to be rather sharply defined, the temperature was not uniform in any one zone and gradations within each zone may be observed, except in zone *D*, which has been subjected only to a strong drawing heat, such as occurs some distance back of the

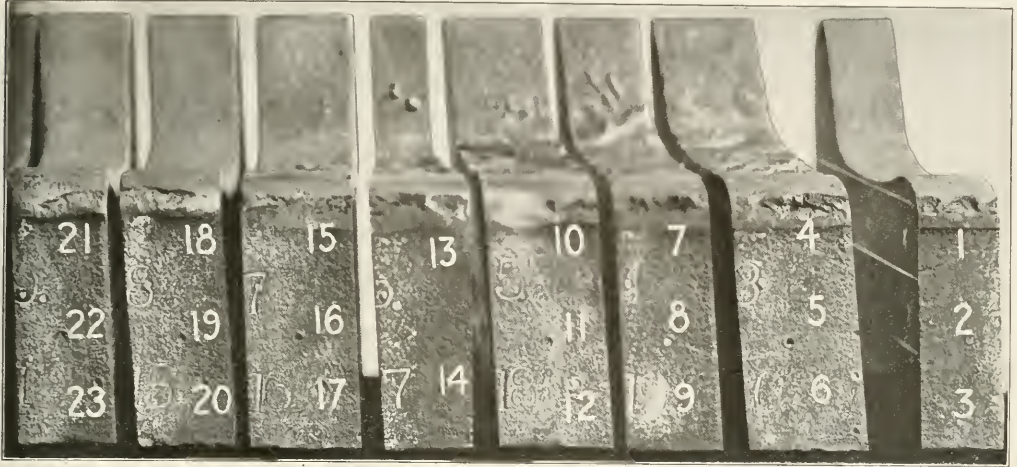

Fig. 3.—Sections Cut From the Tire for Test.

within the critical range, and, therefore, softened, and zone *D*, intermediate in color, which has been heated below the critical range and, therefore, is not changed from the original with regard to grain size. This last represents, as nearly as

point when a cold chisel is tempered after hardening. This heat has altered the physical properties, although it was not high enough to affect the grain size.

The light section of zone *C*, at the left of Fig. 5, is caused by the material in that vicinity having been heated twice. The added material was here first applied lengthwise near the flange, and later the welder returned along the outside of the tire, resulting in the second heating. Such an appearance is always noticeable when the material is so added.

The microscope is necessary to show the changes in the

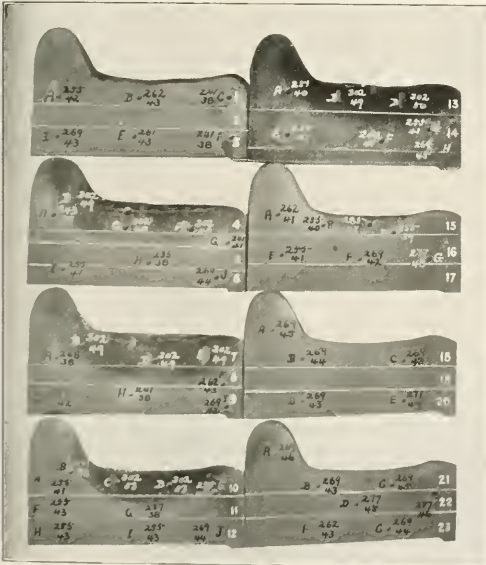

Fig. 4.—Sections Polished and Etched Showing the Hardness Numbers

possible, the original condition of the metal before the welding was done. There are also narrow transition zones between *A* and *B*, *B* and *C*, and *C* and *D*, which will be considered later.

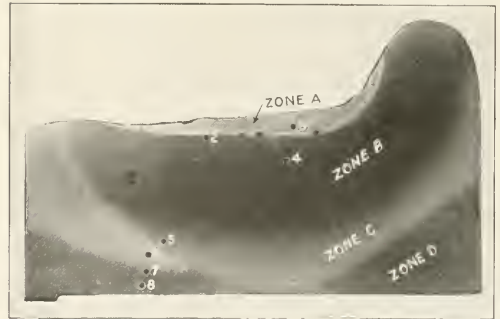

Fig. 5.—Etched Section Showing Different Zones and Location of Photomicrographs

transition zones and the most important of these is the one between *A* and *B*. Here the steel has been decarbonized by the heat, and contains probably about an average of .4 per cent carbon. The width of this zone is from .05 in. to .08 in., and will vary with the temperature and its duration.

The zones between *B* and *C*, and *C* and *D* are wider, although it is hard to give the dimensions. And while there are considerable differences in the structure of the pearlite in any one zone, and while the difference between what might

be called a maximum condition in one zone and a minimum condition in another zone may be small, yet the *average* condition in one zone is very different from that in the other

may be raised to their not being taken parallel with the rolling, yet as the object was to see if any difference existed between the physical properties of the different structures, and as they are all taken in the same direction, it is believed that the results are comparative. A Berry strain gage was used to obtain the elongation.

It should be remembered that it was impossible to get the test pieces exactly from the places desired, and as the structure throughout any zone is not absolutely uniform, it could not be expected that the results of the physical tests would be exactly, or even very closely, the same for what appear to be the same zones. But, from appearance, test pieces 1 and 23 would be in the same zone—both of unaltered material; 4, 7, 13 and 15 would belong together, and so would 6, 9 and 14. No. 5 would seem to be in a class by itself. (These are the only test pieces from which accurate results were obtained.) It is rather noticeable that the stress-strain diagrams confirm these conclusions, as shown in Figs. 6, 7 and 8.

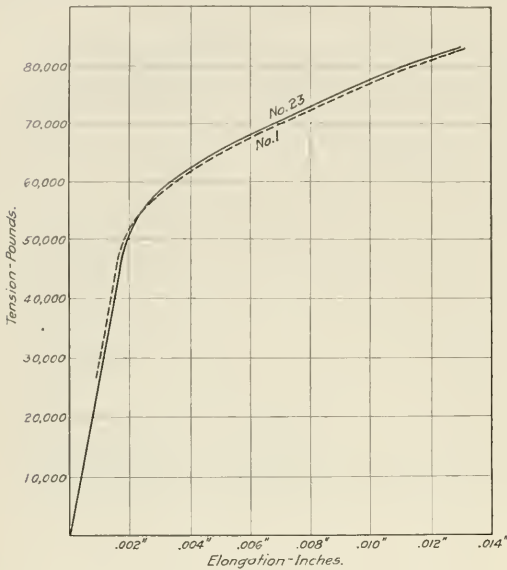

Fig. 6—Stress-Strain Curves For Original Material.

zone. A moderate magnification is best for locating such differences.

Tensile test pieces were cut from each section, so as to in-

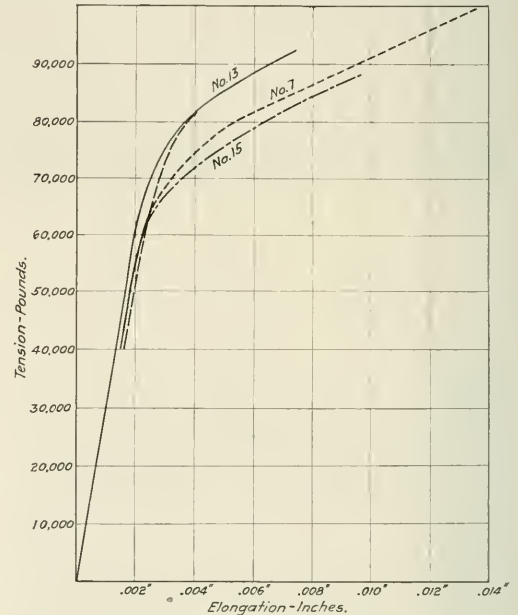

Fig. 8—Stress-Strain Curves For Zone B.

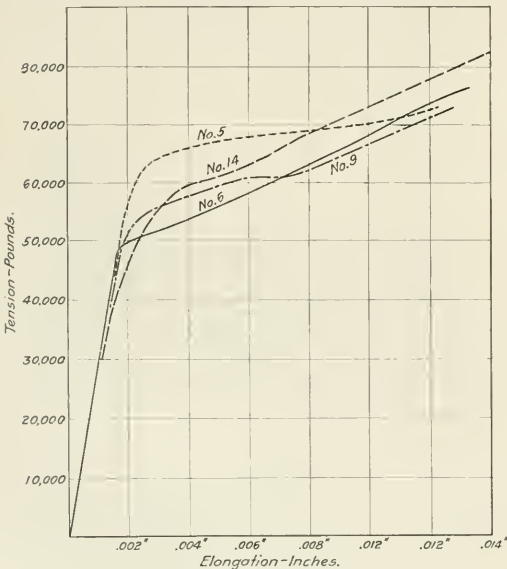

Fig. 7—Stress-Strain Curves For Zones C and D.

The curves for test pieces 1 and 23 are of the same type, and lie remarkably close together. Those for 4, 7, 13 and 15 are of a much different type, the elastic limit being noticeably higher, and the material being much more brittle. Those for 6, 9 and 14 show a still different type, of a characteristic general shape, with a much lower tensile strength, but with the elastic limit nearly the same as 1 and 23. No. 5 is somewhat different from the other three types, but approaches 6, 9 and 14 most closely, and so is shown on that diagram.

The average physical properties of the different zones are shown in the table on the following page.

Almost a casual glance at this table will show the great changes that have taken place in the tire due to the heat. In all cases, the tensile strength is lowered. In the darkened section, zone B, which, in places, occupies about half the area, the elastic limit has been raised over 25 per cent, and the elongation and reduction of area decreased over 50 per cent. Certainly if the physical qualities shown by the original material are within reasonable distance of what is correct

clude the different structures as nearly as possible and these were taken as shown by the white figures in Fig. 4. It was necessary to take them across the tire, and while objection

for tire steel, those in zone B should not be tolerated, and the 11 per cent decrease in tensile strength of zones C and D should at least be looked on with suspicion.

The Brinell and scleroscope figures are given in Figs. 4 and 9. Both of them indicate in a very striking way the differences in the zones, and the scleroscope figures in Fig. 9 show clearly the gradations in the zones before referred to. Both appear to be more nearly related to the elastic limit than to the tensile strength. It will be noted that the metal in the zones as laid out shows to be fairly uniform in any one zone, but that the zones differ quite widely from each other.

Zone A is very soft as it is composed of low carbon material, and no readings are given as they would not bear on the subject.

The metal in zone B is quite uniform, and is in harder condition than the rest of the tire metal. This is as would be expected, as the metal in this zone received a virtual quench.

The metal in zone C is necessarily less uniform than in zone B, as the condition of the metal in this zone varies somewhat from one side of the critical range (within which this metal was heated) to the other. This zone has the softest

The average hardness of the different zones may be given as:

Zone	Brinell	Scleroscope
Zone B.....	300	49
Zone C.....	248	39
Zone D.....	263	42
Original.....	265	44

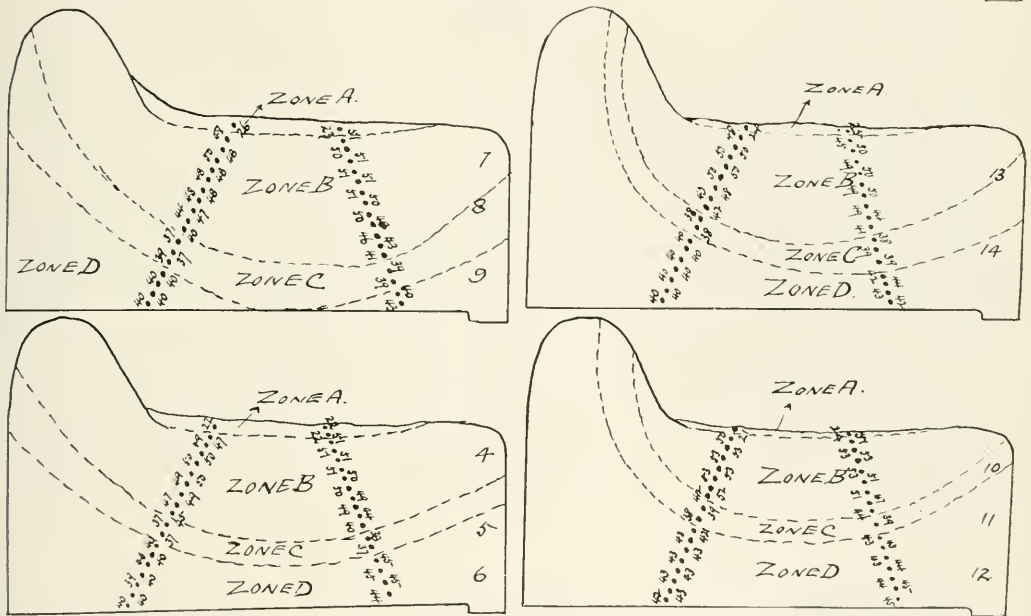

Fig. 9—Limits of Zones Determined by Hardness Tests.

metal of any zone throughout the tire, as would be expected.

The metal in zone D shows the effect of the heating of the tire during welding and it has an effect of a more or less severe "draw" (by "draw" is meant a heating to and cooling from a temperature which is below the critical range). This

MACRO- AND MICRO-STRUCTURE

Photomicrographs, Figs 10 to 30, show the structure of the test pieces 3-16 in. from the fracture, and of several spots located and numbered in Fig. 5. One series was taken at 430 diameters and another at 1,200 diameters. It is difficult,

Zone	Test pieces	Tensile strength	Elastic limit	Elongation in 2 in.	Reduction of area	Hardness		Modulus of Elasticity	Modulus of Resilience
						Brinell	Scleroscope		
Original.....	1, 23	125,250	45,750	3.25 per cent	2.97 per cent	263	43	28,950,000	36.1
B.....	4, 7, 13, 15	120,900	57,700	1.50 per cent	1.45 per cent	298	49	29,950,000	53.9
C & D.....	5, 6, 9, 14	110,860	45,500	3.88 per cent	3.07 per cent	245	40	29,950,000	34.4

metal may, therefore, be expected to show some lack of uniformity in hardness. If, however, the metal at approximately equal distances from the line of the critical range be compared, it will be seen that the hardness is as uniform as might be expected.

in some cases, at either of these powers, especially the higher one, to select a representative field, because of the great variation in even a short distance; but an endeavor was made to come as close to the desired result as possible, a number of photomicrographs being made from each test piece, and

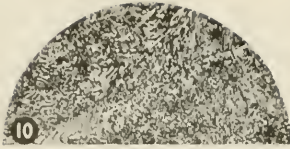

Fig. 10—Test Piece 1—430 Dia.



Fig. 11—Test Piece 1—1200 Dia.

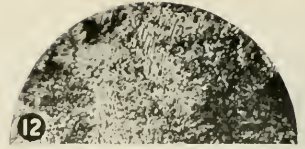

Fig. 12—Test Piece 23—430 Dia.

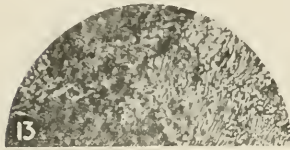

Fig. 13—Test Piece 23—1200 Dia.

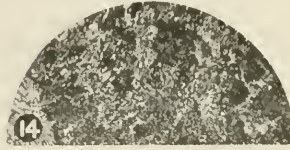

Fig. 14—Test Piece 15—430 Dia.

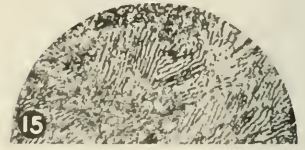

Fig. 15—Test Piece 15—1200 Dia.

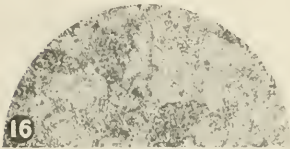

Fig. 16—Test Piece 5—430 Dia.

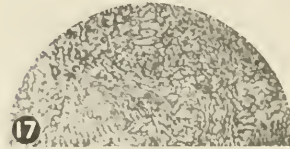

Fig. 17—Test Piece 5—1200 Dia.

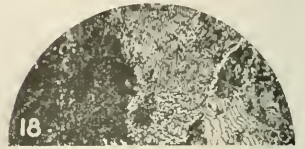

Fig. 18—Test Piece 6—430 Dia.

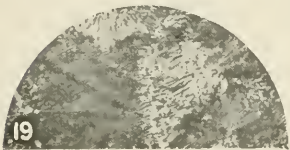

Fig. 19—Test Piece 6—1200 Dia.

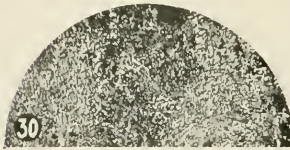

Fig. 20—Test Piece 9—430 Dia.

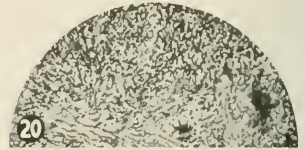

Fig. 21—Test Piece 9—1200 Dia.

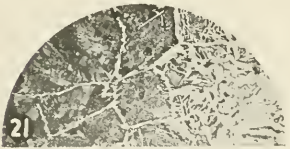

Fig. 22—Spot 2, Fig. 5—50 Dia.

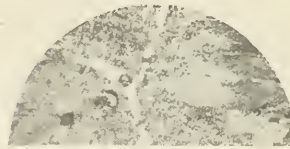

Fig. 23—Spot 4, Fig. 5—430 Dia.

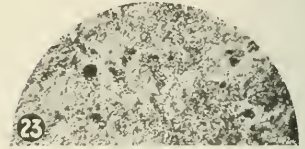

Fig. 24—Spot 5, Fig. 5—430 Dia.

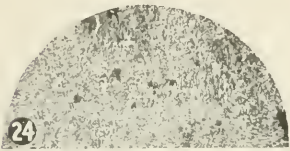

Fig. 25—Spot 6, Fig. 5—430 Dia.

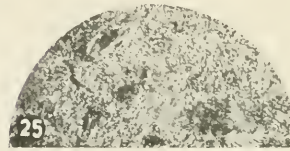

Fig. 26—Spot 7, Fig. 5—430 Dia.

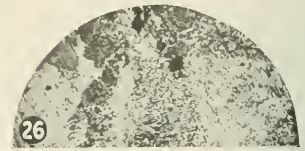

Fig. 27—Spot 8, Fig. 5—430 Dia.



Fig. 28—Spot 10, Fig. 31—50 Dia.

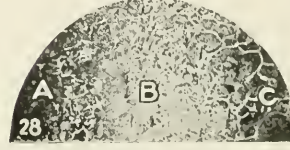

Fig. 29—Spot 11, Fig. 31—50 Dia.

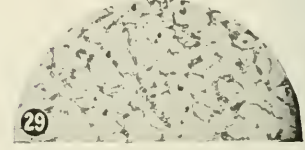

Fig. 30—Spot 12, Fig. 31—200 Dia.

Photomicrographs Showing Changes in Structure of Welded Steel Tires Due to Overheating.

the one appearing closest to the average being selected as representative. It was the aim to correlate, if possible, the physical properties and the microstructure, and although this can be done only in a general way, there seems to be a fair degree of correspondence.

The following table, using the nomenclature of Howe and Levy for the different varieties of pearlite,* gives a fair idea of the essential differences in the zones, and should be compared with Figs. 10 to 30.

Zone	430 diameters	1,200 diameters	Tensile strength	Elastic limit
B.	Sorbite, sublamellar pearlite, ferrite.	Very fine lamellar pearlite, sorbite, ferrite.	120,900 lb.	57,700 lb.
C.	Sublamellar pearlite, sorbite.	Sublamellar pearlite.	110,800 lb.	45,400 lb.
D.	Sublamellar pearlite, sorbite.	Fine lamellar pearlite.	110,800 lb.	45,400 lb.
Original.	Lamellar pearlite, sorbite.	Very fine lamellar pearlite.	125,250 lb.	45,750 lb.

It is interesting to note that the elastic limit in zones C and D varies but little from that of the original, while the tensile strength is much less. Howe and Levy† discovered that, under certain conditions of heating and cooling, steel

Under higher magnification (1,200 diameters) the sorbitic parts shown in Figs. 23 and 27 usually resolve into lamellar pearlite, those in Fig. 27 being coarser than in Fig. 23. This can also be seen by comparing Figs. 10 and 12 with Figs. 11 and 13.

Zone C, Fig. 25, is practically free from lamellar pearlite and sorbite, and is composed almost entirely of what Howe and Levy call sub-lamellar and granular pearlites. It is very similar to Fig. 20. The intermediate zone, between zones C and D, consists of a mixture of the elements of the two zones, and is shown in Fig. 26, which shows both lamellar and sub-lamellar pearlites.

The transition zone between zones B and C as shown in Fig. 24, consists of a mixture of sorbite and sub-lamellar pearlite.

Fig. 28 shows the effect of simply heating the tire to the melting point, and Fig. 30 shows the change at a higher magnification, from which it would appear that the carbon has been reduced, at least in places, to about .4 per cent.

Fig. 22 shows the transition zone between zones A and B. The decarbonization of the original material is clearly shown



Fig. 31—Structure of Test Piece After Being Heated to the Melting Point—3.5 Diameter

of .92 per cent carbon loses much of its tensile strength, while the elastic limit is but little affected. It may be considered that the above figures tend to confirm this, although the temperatures and rates of cooling are not accurately known; also, the test pieces were taken crosswise of the tire, so that actual comparisons cannot be made. But it appears that breaking up of the cementite in the pearlite, or, in other words, deviating from normal lamellar pearlite, decreases the tensile strength materially, though it may not affect the elastic limit.

The change in structure is well shown in Figs. 23, 25 and 27, at a magnification of 430 diameters, and should be compared with Figs. 10 and 12. They are taken from the section shown in Fig. 5, at the points marked 4, 6 and 8. At this magnification, the structure in Fig. 23 is much more sorbitic and also finer grained than that in either Figs. 25 or 27, and it would be expected that such material would be stronger, but more brittle, than materials typified by the other photographs.

It should be noted that, in zone B, there are frequent plates of free ferrite, which are rarely seen in zones C and D.

by the white ferrite films around the grains in the left half of the photograph. The right half shows the added material.

This is another matter that militates against the use of any welding process in connection with tires. The heat, combined with the oxygen in the air, will certainly remove from the steel some of its carbon, thus making it unsuitable for tires. It might be thought that such a loss could be counterbalanced by using a higher carbon steel for the added material. But this is not possible entirely, and even then not beyond a certain limit, which limit is too low. For example, the simple melting of a piece of tire steel, before adding any material, produces a structure as shown in Fig. 31 at the right; while the use of drill rod containing about .9 per cent carbon results as shown in the same figure at the left.

It also appears that the higher the carbon, the greater the proportionate amount burnt out in a given time; i. e., if a .9 per cent carbon rod is used, the carbon will probably be reduced, as shown roughly by the microscope, to between .5 per cent and .6 per cent, or a reduction of about 40 per cent. There is certainly no such reduction in the case of .08 per cent to .10 per cent carbon steel.

Again, Fig. 29 shows clearly that, in melting the tire steel,

*Journal of the Iron and Steel Institute, 1916, No. 11, page 220.
 †Journal of the Iron and Steel Institute, 1916, Vol. II, page 333

and adding .9 per cent carbon material, there are four zones; the original metal A, with its carbon content unchanged; the original material partly decarbonized by the heat, but not melted B; the original metal, melted and further decarbonized C, and the added material, partly decarbonized (not shown).

It is evidently not possible to change any of the last three zones to the same condition as the original tire metal, either with regard to grain size, carbon content, character of pearlite or physical characteristics. Therefore, it appears to the writer futile to experiment with different added materials, even if no damage of other kinds were done to the tire.

It is not believed necessary to elaborate other objections; but one point should be spoken of. While the writer is not familiar with all the torches on the market, yet none of those he knows of has sufficient capacity to make a sound weld in a tire $3\frac{1}{2}$ in. thick without preheating the tire; and, of course, such treatment would have as bad, if not worse results, as the welding.

The following objections to fusion welding, as applied to tires, are the principal ones:

First: The physical properties of the tire are seriously altered by the heat applied.

Second: It is impossible that the added metal be of the same quality as the original.

Of course, the former is the more important.

Now it may be urged that the fusion welding of tires is a justifiable emergency measure under present war conditions. While the writer believes it a dangerous practice, it might be permissible in certain cases where danger would be a minimum, say in the case of switching engines in light service. But in times of stress in railroad service, temporary repairs are less useful than during periods of light traffic, because any accident causes worse congestion. And there is much more chance of loss of life when large numbers of people are being transported, as at present, than under normal conditions, from any kind of accident. So it appears that any practice carrying with it an element of danger, should not be permitted, especially during periods of stress and hard service.

Of course, it would be entirely possible to restore the condition of the heat changed parts of the tire to their normal state by proper heat treatment. There can be no objection to this, provided it is properly done. Practically no railroad shop has facilities for this work, although they could be readily provided. On the other hand, it is a question if the number of slid flat tires is sufficient to justify the installing of the apparatus necessary, and, under proper conditions of brake equipment, etc., there should be little of this trouble.

So that, everything considered, it is seriously a question if a practice attended with such possibilities of danger should be followed unless the heat treatment referred to can be accurately carried out.

WELDING TUBES IN THE FIREBOX

On page 35 of the January, 1918, issue of the *Railway Mechanical Engineer* appeared a sketch and a brief description of a method of welding tubes in the firebox tube sheets, which has proved successful in preventing trouble from honeycombing. Since the publication of the article referred to, our attention has been called to the fact that this method of welding in tubes was developed on the Chicago & North Western, and an application for a patent on the method was filed early in 1916.

THE TOTAL EXPORTS TO U. S. FROM ENGLAND IN 1917 had an aggregate value of \$262,891,937, against \$303,414,269 in 1916, according to a cable from the American Consul General at London under date of January 2.

TERMINAL TIME SAVING*

BY M. F. C.

Saving time is equivalent to conserving energy provided there is a storage capacity. To save two or three hours at a terminal by some adroit movement and then fail to turn the gain to a profitable account is like putting good money into a bad pocket. A device that really performs and actually reduces the cost beyond the peradventure of a doubt is the thing sought and we must take it into account. It at least deserves notice if not analysis. At this critical juncture when men and machinery are at a tremendous premium, an hour a day per locomotive is a big item and per car yet more. It represents 11 per cent of man's energy and a proportionate percentage of revenue to the railroad, for locomotives and cars are only earning money for the roads when actively engaged in service. Turning a locomotive, therefore from inactivity quickly to activity is doing a big bit toward production. The main money maker—the biggest single factor—the locomotive must be kept going in order to bring home results. For this main reason and obvious others, its every move should be studied.

Winter is a strenuous season for those at the terminals—a very decided taste of trench life. With congested engine houses and facilities generally inadequate, the outlook is anything but inviting. What can be done to improve these conditions and force our equipment into quicker service? About all that anyone can do is to prepare to take care of as many locomotives on the outside as it is possible to do. Extra inspection pits, invaluable things, an auxiliary steam line, air line and portable tools with work sheds here and there will add greatly to the convenience of the men from whom we reluctantly accept excuses. Pits are necessary adjuncts to an engine terminal and locomotives must be placed over them in order that the inspection and repairs be made properly. Sheds should be constructed to shelter the locomotives and repair crews. No mechanic can do justice to a job in a cold sleety rain with snow and slush up to his ankles. Pits of concrete and wood construction can be built rapidly and second-hand piping may be used for steam, water and air lines in emergency. By putting enough men on the job, shelters may be erected in a short time. Some large buildings have been built and made habitable at government camps in 3 to 4 days.

A locomotive coming in from its run should go first to the ash pit; from there it should go into the house and over the pit. After inspection the boiler should be blown out, washed and filled, and the necessary repairs made to the locomotive. There should be no interruption to these operations—if there is, the system is not working as it should. The coal and water should be taken after the locomotive has been repaired. There is no economy in taking coal and water sooner as the tank requires careful inspection as well as the engine. Caring for locomotives in the open at best is a questionable practice. It is altogether impracticable in extremely cold climates. It can be done in an emergency. It is greatly to be regretted that many engine houses and their adjacent track connections are so awkward and clumsy. Having to pass locomotives over the turn table to coal, ash or water is a sure indication that the layout is faulty. The shortest possible distance for accomplishing this turn around is the correct distance to be allowed. Much valuable time is lost due to the fact that locomotive movements are too roundabout.

I am fully aware that many of our engine houses are the products of engineers of the old school. I mean no disrespect to them—they wrought well with the problems of their day, but that day has departed, it is gone forever and we are face to face with the indisputable facts, powerful locomotives, abnormal labor conditions and business heaped

*Entered in the engine terminal competition.

up, and running over with antiquated facilities to contend with at many points. We want no more round houses, it is a modern round shop we require. To overcome these handicaps it is now necessary to study closely side stepping and backward engine movements of every kind and plan to move them in and out in as straight a line as possible touching the various points of contact indicated. It is entirely feasible to do this with wide awake energetic supervision; many miles may be eliminated by avoiding false moves.

The very practical question which is now before every motive power and transportation department is, how quickly can we return our locomotives to service upon arrival and what is the least time consumed for needed repairs. A boiler washing system in full operation will reduce the time as effectively as any single feature I know of. We cannot redesign the engine houses quickly and satisfactorily, but boiler washing systems may be put in on short notice. This will reduce the time from 2 to 2½ hours over the old hand method and cut down the boiler repairs enormously. While doing this by all means install a good big boiler so that there will be an abundance of steam for blower purposes. Much time may be consumed waiting on a weak steam pressure line. Have these boilers carry at least 125 lb. pressure. We have recently taken out a large healthy boiler in order to install one of a better sustaining capacity and high pressure. We are also putting in a number of additional washout systems at the extra busy points, each of which carries with it a 150 h.p. locomotive type boiler. By this method for example we are able to take care of 170 to 180 locomotives with a twenty stall engine house. It is nevertheless, a "nip and tuck," day, night and holiday proposition under ideal weather conditions.

A boiler washing system, locomotive cleaning device, inspection pits, a portable welding and cutting outfit, an abundance of steam and air, a well equipped tool room centrally located so that a tool may be had upon a moment's notice day or night, conveniently located grinders, drills and other machine shop tools will work wonders even at an old fashioned terminal. It has been stated by able men who have studied the matter that locomotives are in the hands of the mechanical department, being prepared to move tonnage 53.9 per cent of the time, therefore offer a bonus for a 15 per cent reduction of this and note the results for the next six months. If this does not revolutionize the old terminal, nothing will.

TESTS OF OXY-ACETYLENE WELDED JOINTS IN STEEL PLATES

In view of the big increase in the use of welding processes in firebox construction, recent tests on the strength and efficiency of oxy-acetylene welded joints in steel plates conducted by the Engineering Experiment Station of the University of Illinois and published in Bulletin 95 are of interest and value. The joints were welded by skilled workmen in a plant especially equipped for oxy-acetylene welding and the results are probably a little better than could be obtained under common shop conditions.

Laboratory tests were made under three conditions of loading: (a) Static load in tension; (b) repeated loads (bending) and (c) impact in tension.

The static tension tests give an index of the resistance of the welded joints to loads applied only a few times and without heavy impact. The repeated stress tests give an indication of the resisting power of the welded joints to loads repeatedly applied, such as loads carried by springs and axles. The impact tests give an index of the ability of the welded joints to resist sudden heavy shocks without complete rupture and high resistance to rupture under impact represents insurance against the sudden and complete failure of a part subjected to severe bending or stretching.

This quality is of great importance in material for machine parts or for railway service.

The plates in which the test joints were made were steel with a carbon content of about .16 per cent and the following thicknesses of plate were used: No. 10 gage, ¼ in., ½ in., ¾ in. and 1 in. After welding, the plates were cut into test pieces and tested under the three conditions of loading as mentioned above.

Some of the comparative efficiencies are shown in the table, and the variations in yield point are shown in the chart.

A summary of the results is as follows: The tests were made on joints welded by skilled workmen and should not be considered as indicative of the strength of welds made in repair shops, or of welds made by workmen without special training in the use of the oxy-acetylene torch. For joints made with no subsequent treatment after welding, the joint efficiency for static tension was found to be about 100 per cent for plates ½ in. thick or less, and to decrease for thicker plates. For static tension tests, the efficiency of the

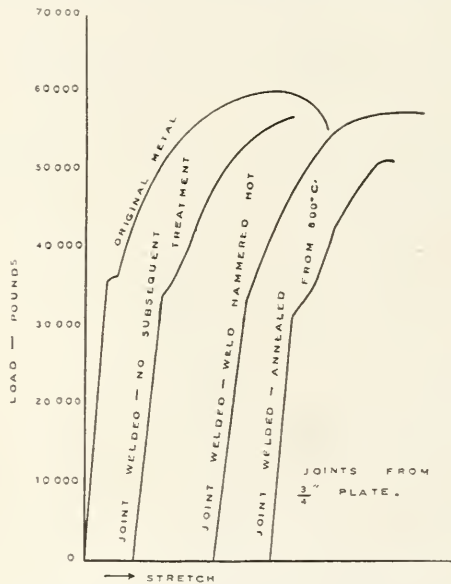

Stress-Strain Curves for Oxy-Acetylene Welded Joints.

material in the joints welded with no subsequent treatment is not greater than 75 per cent. The joints were strengthened by working the metal after welding, and were weakened by annealing at 800 deg. C.

The results of the repeated stress tests give an index of the inherent qualities of the joints and they follow in a general way the results of the static tests. For repeated stress tests the joint efficiency seems to be about 100 per cent for plates ½ in. or less in thickness, while the efficiency of the material in the joint is somewhat less. Hammering or drawing the welds while hot increases the strength and annealing from 800 deg. C. lowers it.

For static tests and for repeated stress the joint efficiency sometimes reaches 100 per cent, but the efficiency of the material in the joint is always less. This indicates the necessity of building up the weld to a thickness greater than that of the plate.

The impact tests show that oxy-acetylene welded joints are decidedly weaker under shock than is the original material; for joints welded with no subsequent treatment, the

strength under impact seems to be about one-half that of the material.

If the welded joint is worked while hot, the impact resisting qualities are slightly improved, although this does not make the joint equal to the original material in impact resisting qualities. Annealing from 800 deg. C. seems to have very little effect on the impact resisting qualities.

In general the test results tend to increase confidence in the static strength and in the strength under repeated stress of carefully made oxy-acetylene welded joints in mild steel plate.

EFFICIENCIES OF OXY-ACETYLENE WELDED JOINTS IN PER CENT

	Joint Efficiency		
	Static stress	Repeated stress	Impact
Thickness of plate.....	1/2 in.	1/2 in.	1 in.
Original material.....	100	100	100
Material of plate, annealed from 800° C.....	89	84	89
Joint welded, no subsequent treatment.....	100	100	53
Joint welded, annealed from 800° C.....	92	93	35
Joint welded, quenched, annealed from 800° C.....	92	94	32
Joint welded, hammered while hot.....	101	107	58
Joint welded, hammered, annealed from 800° C.....	95	102	53

DEVICE FOR MILLING KEYWAYS FOR ECCENTRIC ARMS IN CRANK PINS

It is difficult to secure the correct alignment of the keyways in crank pins and eccentric cranks if they are laid off before the crank pin is pressed in the wheel center. Many roads follow this practice, however, because of the difficulty of cutting the keyway after the pin is in place. The drawing

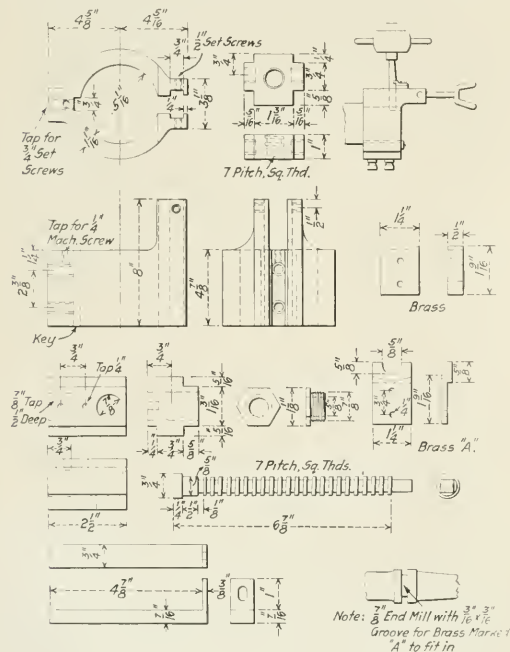

Details of Keyway Milling Attachment

below shows the details of a device that is used at the West Burlington shop of the Chicago, Burlington & Quincy for doing this work. It consists of a guide which fits over the end of the crank pin and is held in place by a key and two set screws. On the side of the guide opposite the key is a slot, at the end of which is a nut through which the feed

screw passes. The outer end of the feed screw has a handle while the inner end fits in a bearing for the cutter. This bearing rests in the slot and can be moved back and forth by the feed screw. On the upper side of the bearing is a lug which fits in a groove in the milling cutter and regulates the depth of the keyway. The cutter is driven by an air motor as shown in the sketch of the assembled device.

A SHOP STORY WITH A MORAL

BY A TRAVELING AUDITOR

I recently had occasion to check a statement covering repairs to a locomotive, which included the application of a superheater, and I soon discovered that the distinction as drawn between additions and betterments and the operating charge was at too great a variance and that the figures would have to be rechecked and adjusted in order to satisfy the Interstate Commerce Commission.

Investigation of the method of determining the amounts developed that the shop employee at the close of his day's work made out a time slip on which he endeavored to show the hours put in on the various jobs during the day. He relied entirely on recollection. This system, I knew, would not come up to I. C. C. requirements as something more definite was needed.

On putting it up to the shop management to devise some other system whereby the figures would be more accurate, we were informed that there was only one way in which this could be accomplished and that was through the employment of a staff of clerks whose duties would be to follow through all operations wherein the additions and betterment charges were concerned. This proposed plan was put up to me for approval and I promptly vetoed it as I knew it could be worked out with the present organization and I made the statement that any additional men would mean money wasted.

My suggestion was to have the gang foreman in charge of the work keep track of the time of such of his men as were working on the addition and betterment job and to support my contention I offered the following argument:

The gang foreman knows just where to draw the line as between the addition and betterment and the operation charge. He is the man who orders the material and shows on the material ticket the proper charge; he is the man who lays out the work, that is, tells this or that man just what to do and he, therefore, would be in a better position to keep the time and distribution of the men than they would be, and if he would devote 10 or 15 minutes of each hour to this clerical work we could get a very accurate account of the charges.

Very plausible, indeed! In fact, so plausible and simple that I was immediately sent to the shop to organize for this work, and I will confess I was more or less conceited by the fact that my solution of the problem had been so readily accepted.

On arriving at the shop I found that the master mechanic was absent, so I went to the "next best," the general foreman of the locomotive department, with whom I was intimately acquainted. He proved to be a very respectful listener. I explicitly laid my program before him, explaining its advantages, the necessity for it, the expected result, etc.

I was ready to call the shop organization together and line them up, when the general foreman stopped me by saying, "I have listened with interest to this splendid theory of yours and I am going to ask one favor of you before you put it into effect. I want you to come to the plant at 7:00 a. m. tomorrow prepared to spend the day with us and follow just one suggestion of mine. It may be that the experience you get will cause you to slightly change your plans;

in fact, I want to put to test a theory of mine and that is that the average clerk is prone to inaugurate systems in shops without knowing the inside workings and if he were intimate with shop conditions he might hesitate."

I could see no harm in the suggestion and very promptly agreed, and was at the shop the next morning at the appointed hour.

"Here is my suggestion," said the general foreman. "As you know, we have 42 pits in the machine shop, divided into seven gangs of six pits each; one gang foreman to each gang. I want you to choose one of the seven gang foremen, report to him immediately, and follow him every minute of the day. Report to me your conclusions at the close of the day."

I followed this suggestion and incidentally followed the gang foreman of my choice for nine long hours. Between laying out the work for 53 men, including mechanics, helpers, handymen and apprentices, on six locomotives, making out requisitions for necessary material, going to the blacksmith, boiler and tin shop to rush material, following up an engine just off one of his pits, which was being completed in the roundhouse, answering questions of his and other men, signing up time sheets, approving distribution slips, keeping a record of the work going on so he could make a report in detail when the locomotives were repaired and making up two reports of this kind for locomotives recently completed, this gang foreman did not have a minute to spare in any one hour. He even lacked the opportunity to study his work, to plan what to do next and the most practical way of doing it, and as to squeezing in 10 or 15 minutes additional clerical work an hour—well, I very soon appreciated that a nine-hour day was altogether too short a time for the work already allotted to him.

At the expiration of the ninth hour, mentally and physically wearied, I reported to the general foreman by simply saying "You win."

He responded: "Mr. Blank, I knew I would, and I want to say to you, a representative of the general officers, that if any more clerical duties are put on my gang foremen, it will mean they will have to shirk one of two duties—that of repairing locomotives or that of clerical work."

Again I agreed with him as I had satisfied myself that he was absolutely correct. What I had set me to thinking. I began to ask myself several questions:

1. To what extent were we paying high salaries to men who put in a portion of their time performing minor clerical duties?

2. To what extent was the output from these men being hampered by the trifling duties constantly being saddled on them?

3. How many of the statements they were required to prepare were necessary and could not a number be eliminated; was the time put in on them worth while?

4. If the mechanical department supervisors were suffering from this, how about the transportation department, road department and others?

My little adventure at the shops bore fruit, however, as the report of my conclusions resulted in a vigorous campaign throughout the entire railroad, with a view of eliminating or reducing, so far as possible, the clerical duties of lead men, as well as reducing or eliminating statements and reports from all departments regardless of the duties of the men making them.

The first step in this campaign was the appointment of three senior clerks in each department—three men from the traffic department, three from the mechanical department, three from the transportation department, etc., who were thoroughly familiar with the various needs of their department, insofar as reports and statements were concerned.

After the committees of three had concluded their department investigations, which resulted in many reports being

entirely eliminated, a number of others reduced and in all possible cases the duty of making reports placed on non-productive labor, namely clerks, the several committees got together to investigate the necessity of certain reports made by one department to another. This resulted in a further elimination.

The reduction in work of this nature was astonishing and one wondered what conditions brought about so much unnecessary data. The committee with which I was connected concluded that in the majority of cases this condition was brought about by transfer of a department head to some other point or department. In his last position he was receiving a certain statement, drawn up in a certain manner and it was very natural that he should want similar information—but never a thought would be given to statements regularly coming in for which he in his new position had no use.

Another contributing factor was discovered. A statement would be inaugurated to cover a change in standard and a monthly report would be requested in order to keep a line on the change; the change would be brought about, but for months and even years the same statement would be furnished, with nothing to report. The information required was an absolute necessity at the time the report was inaugurated, but although this necessity had long since ceased to exist, there was a hesitancy to discontinue the statement "for fear someone would some day want it."

Another benefit of our campaign, which is not to be scoffed at in these days of high prices, is the saving in stationery. A sheet of paper saved here and there, in the aggregate most certainly effected a decided economy.

The campaign apparently has had a lasting effect, because to this date the evil of unnecessary statements and reports has failed to crop out.

This subject should be food for thought to all who have overlooked this important feature of non-productive effort, common to all railroads.

As to the moral—well, there are several.

GRINDING SUPERHEATER HEADER

The work of grinding the steam pipe joint rings on superheater headers is usually done by hand and is a slow and tedious job. The device illustrated below was developed

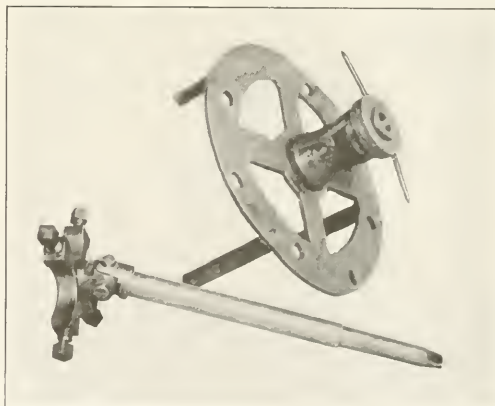

Device for Grinding Superheater Joint Rings

in the Clinton, Iowa, shops of the Chicago & North Western to make it possible to grind these joints with an air motor. The ring is held by set screws on the chuck which is attached to the spindle by a universal joint. The frame

is arranged so that it can be bolted to the flange of the header and has an eccentric bushing through which the spindle passes. In operating the device the spindle and frame are placed in position and an air motor is attached to the spindle. Then by revolving the eccentric bushing by means of the short handles in the outer collar while the spindle is driven by the motor, the ring is moved over all parts of the joint on the header, producing a smooth, true surface.

REDUCING THE TIME TO TURN LOCOMOTIVES*

BY T. T. RYAN

General Foreman, Atchison, Topeka & Santa Fe, Las Vegas, N. M.

To get a locomotive over the road promptly, to get the crew off and the engine house crew on it promptly, to handle it in modern time across the cinder pit, past the coal dock, have it cleaned and inspected and put in the engine house and then to have it promptly and properly cared for, got hot and started back on another trip constitutes the sole reason for building expensive terminals or engine houses.

Careful handling of trains by the dispatcher which results in a train getting over the road does as much toward keeping locomotives in shape to turn promptly as any other one thing. If we follow the dispatcher and trainmaster closely and get them to understand how by avoiding side track delays they may help and explain to them the damage caused by thus holding trains, we will find that they will do all they can to help. We are prone to criticize these men too much anyhow; it would be vastly more to the point if we would spend some time with them and help them to construct a better policy than to continually criticize them. If it is necessary to criticize let it be constructive.

The time at terminals may be reduced by greater effort on the part of employees to make the best use of the available facilities and it may also be reduced by providing modern facilities to take the place of those that are out of date.

The first method is immediately available at all places regardless of whether the facilities for turning engines are modern or not. It only requires the right kind of supervision and enough of it. Railroads are about the only concerns that have been inclined to work with a minimum of supervision and it is likely that this is a relic of the time when all the workers were more skillful, more versatile, and approached their tasks in a different frame of mind than they do nowadays.

There are today many modern terminals for turning locomotives that leave little if anything to be desired in the way of facilities. With these there is nothing needed except to systematize and speed up the work. There are many though, and often ones of importance that have badly arranged tracks, poor coaling stations, hand operated cinder pits and cold water washing plants, together with utterly inadequate tools for doing the mechanical work required.

LOCATION OF TRACKS

The tracks should be so located that the method of approach or routing will be direct and continuous past the cinder pit, the coal chute, the water cranes, the cleaning shed, the turntable to the house.

When in the course of the performance of these operations it is necessary to shift the locomotive from one track to another or around other locomotives or to delay the inbound locomotives on account of outbound locomotives valuable time is lost that cannot be regained. It is not uncommon to find locomotives standing outside the terminal for hours after their arrival at a terminal on account of lack of room. A terminal that handles thirty locomotives per day and loses

only an hour on each has lost one locomotive for three ten-hour days or at fifteen miles per hour has lost the movement of a tonnage train four hundred fifty miles. Multiply this by the terminals in the United States and see what the figure leads to. Or put it another way. There are approximately 70,000 locomotives in the United States; let each locomotive lose an average of two hours out of the twenty-four and note the result. At ten miles per hour each locomotive has lost twenty miles or a total loss of 1,400,000 engine miles per day.

CINDER PIT

The next point of consideration should be the cinder pit. We have at many places, in fact in the majority of places, hand operated cinder pits. There is no question that these pits cost a great deal in time lost and in money expended for labor. Take a point turning 1,200 to 1,500 locomotives per month. It is certain to take at least two shifts of four men each to handle the cinders. This will figure at the very least at the present time \$16 per day to handle the cinders without allowing anything for the extra hostler force necessary to handle the locomotives on account of the fact that the locomotives cannot be moved quickly.

Cars are difficult to secure for the cinder pit and too often we find locomotives delayed because cars cannot be obtained. Still more often we find that locomotives are not being gotten in the house for repair because the force on the cinder pit is down to one man. Who has not been a night engine-house foreman and on coming to work at seven p. m. been greeted with the information by his hostlers that the cinder pit was full and the night men had not shown up for work. Then he has had to go and take the wipers or laborers out of the enginehouse and send them to the pit with the result that important other work had to be left undone.

There is another way that this causes the loss of not only time but money as well; locomotives are delayed at the cinder pit and on this account it is often necessary to call day men back at night paying them extra money for a poorer grade of work than would have been done in the day time. I think that every man who has run an enginehouse will agree that overtime work is undesirable from every point of view. The workman who has performed a hard day's labor is in no shape to come back at night and do good work and still less is he able to come to work again the following morning and do good work throughout the day. The vast majority of mechanics do not want to work overtime.

It is a refreshing fact, however, that our progressive general managers and mechanical superintendents today are seeking and installing the best there is to be found in the way of mechanically operated pits that do away with the trials of a hand operated pit.

COAL CHUTE

The next step in natural order is the coal chute. It should be also of modern type to avoid delay and it is well to operate the coal chute and the sandhouse in combination with each other. Any of the modern plants are good and all of the old type pocket chutes are bad; they consume unnecessary time and time is the greatest asset that we have at the present.

That the modern coaling systems are necessary is so well recognized that a discussion of them would seem superfluous.

The water cranes should be installed to avoid any delay in taking water due either to capacity or to having to shift the locomotive from one track to another. The writer has seen a plant with the coal dock on one track, the cinder pit on another and the water crane on still another, making three tracks that the hostler had to put the locomotive on before it finally arrived at the enginehouse.

CLEANING

During recent years since the advent of modern power, locomotives have been wiped; they have not been cleaned.

*Entered in the engine terminal competition.

Mechanical cleaning is coming and it is coming to stay. Mechanical men are recognizing that locomotives to be kept in first class condition must be clean so that they can be inspected and so that the men can work on them. In addition to this, labor is becoming so scarce and costly that we cannot afford to tie up a large number of men to wipe locomotives which may and should be cleaned by one-twentieth of the present number.

It would seem that the proper place to clean a locomotive would be outside the enginehouse and it should not consume over twenty minutes. Why should we take a locomotive in the house and clean it and then hire men to haul the dirt out? Would it not be vastly better to clean the locomotive outside and avoid this extra expense and at the same time eliminate that curse of every enginehouse foreman namely, wet and dirty pits.

WASHING BOILERS

Every point that washes a boiler should have hot water to wash with. Cracked sheets, leaky flues, delayed traffic, broken staybolts, are only a few of the evils attendant on a cold water washing system. Properly handled with a cold water plant we may not expect to cool a large modern locomotive, wash it, fill, fire and get it hot in less than eight to ten hours' time. Properly handled or not, we will not beat this, for if we do not handle it properly we will damage it so that in the end we will hold it out of service long enough to make repairs to bring the average up to this figure.

With a proper hot water washing plant the boiler should be washed and made hot in four hours. To figure the saving is a simple mathematical proposition.

REPAIR GANGS

The work of the repair gangs is a matter of organization, and so handling the work that it will proceed in a regular and orderly fashion; so well systematized that each necessary repair will follow in its proper place with a minimum of delay to the others. Each regular and standard operation should be assigned to some one assigned to that particular duty who will be held responsible for its performance.

Proper tools to do the work should be provided and the work should be done in the quickest and least expensive way. The tools should be cared for and be kept available at all times.

In conclusion: We may reduce the time that is being taken to turn locomotives now by a large per cent without the outlay of money and at the same time increasing the output simply by re-organizing the forces where necessary and by finding a way to inspire the workmen with the zeal. Having done this, having cut out all lost motion, the rest we gain must be done by adopting improved methods. This calls for an initial outlay of money but the saving to be effected will more than justify it.

MILLION AND A HALF SOLDIERS MOVED BY RAILROADS.

Figures compiled by the Railroads' War Board indicate that the railroads of this country have safely transported approximately 1,500,000 soldiers to training camps and embarkation points since August 1. One-third of these men have made journeys necessitating overnight travel and have been moved in tourist or standard sleepers. On one of the long hauls 8,000 men were moved from a training camp on the western coast to a point on the eastern coast—a distance of 3,700 miles—in a little less than a week. The men traveled in 16 sections, each section comprising 12 tourist cars and 2 baggage cars. As a result of co-operation between the government, the railroads and the Pullman Company, 500,000 soldiers have been spared the discomforts of making long trips in day coaches. To assure the safety of the men in transit, the railroads have adopted an average speed of 25 m. p. h. for all troop trains except when freight cars are included in trains. The speed is then reduced to 20 m. p. h.

GLASS SHIELDS FOR GRINDING WHEELS

The practice of supplying goggles for the use of workmen while grinding tools is followed by many roads. It has certain disadvantages, however, as the expense of furnishing goggles to all employees who grind tools is a considerable item and men are apt occasionally to neglect to use them. For these reasons some roads prefer to protect the men using grinding wheels by a shield on the machine itself. An ef-

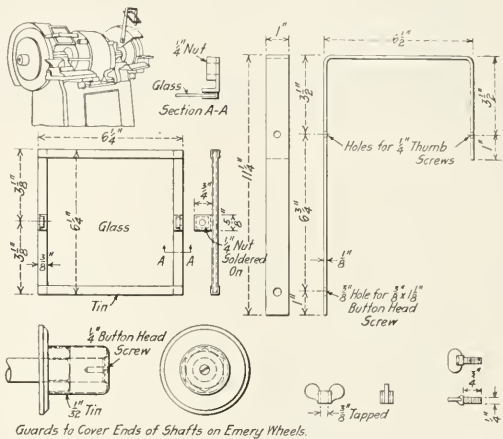

Safety Devices for Grinding Wheels Used on the North Western

fective device for this purpose, which is in use on the Chicago & North Western, is shown in the illustration. It consists of a movable arm attached to the grinding wheel shield carrying a frame which holds a piece of glass 6 in. square. The glass can be set at any angle desired, which makes it possible to bring it in a position where it will afford protection without interfering with the view of the piece being ground.

REMOVING BOILER TUBES

The appliance illustrated below, which is used at the Clinton shop of the Chicago & North Western, has been

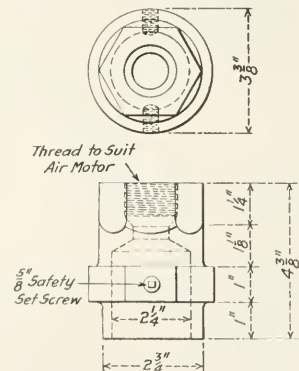

Socket Used with Air Motor for Removing Boiler Tubes

found effective for removing boiler tubes when they cannot be passed through an enlarged hole in the tube sheet. It can be attached to an air motor of either the standard or close-quarter type. When the tube has been cut off it is driven a short distance through the front tube sheet, the

socket is placed over it and the set screws are tightened. The tube can then be revolved by the air motor, thus readily removing the scale as the tube is drawn out.

CLAW BAR DIES

BY F. B. NIELSEN

Blacksmith Foreman, Oregon Short Line, Pocatello, Idaho

The set of dies illustrated below for the making of claw bars of material from the scrap pile.

By the use of these dies, considerable saving is being effected in the Pocatello shops. The claw bar, which is shown in Figure 3, has a machine steel shaft with a crucible tool steel claw, and was formerly purchased at a cost of \$1.95. Our claw bars are now made with the dies at a cost of 70 cents each, utilizing scrap tire steel for the claws to which are welded handles from the discarded claw bars.

A large number of scrap tire steel claw bars were fur-

3 1/2 in. by 11 in. Heat and place one end on the tip of die No. 1 and hammer down until it takes the shape shown in Fig. 1. Note that die No. 1 is roughened for a distance of 3 in. from the tip which prevents the bar from slipping.

Operation 2.—After heating, place the material in die No. 2 which rounds off the end as shown in Fig. No. 2. Then, while the bar is hot, draw out the foot to take the shape shown in Fig. 2. The two 1 1/4-in. plates riveted on the sides of die No. 2 and extending above the tip 1 1/16 in. prevents injury to the die during the cutting off operation.

Operation 3.—Again heat and place the material in die No. 3, which, with the use of the flatter shown in Fig. 4, gives the 5 1/2-in. radius to the claw shown in Fig. 3.

Operation 4.—After heating, place the bar in die No. 4 and strike the countersunk punch which swings on the 1-in. bolt. This countersinks the claw for the spike head.

Operation 5.—Again heat and place the bar in die No. 5, which, with the punch, forms the 3/4-in. slot in Fig. 3.

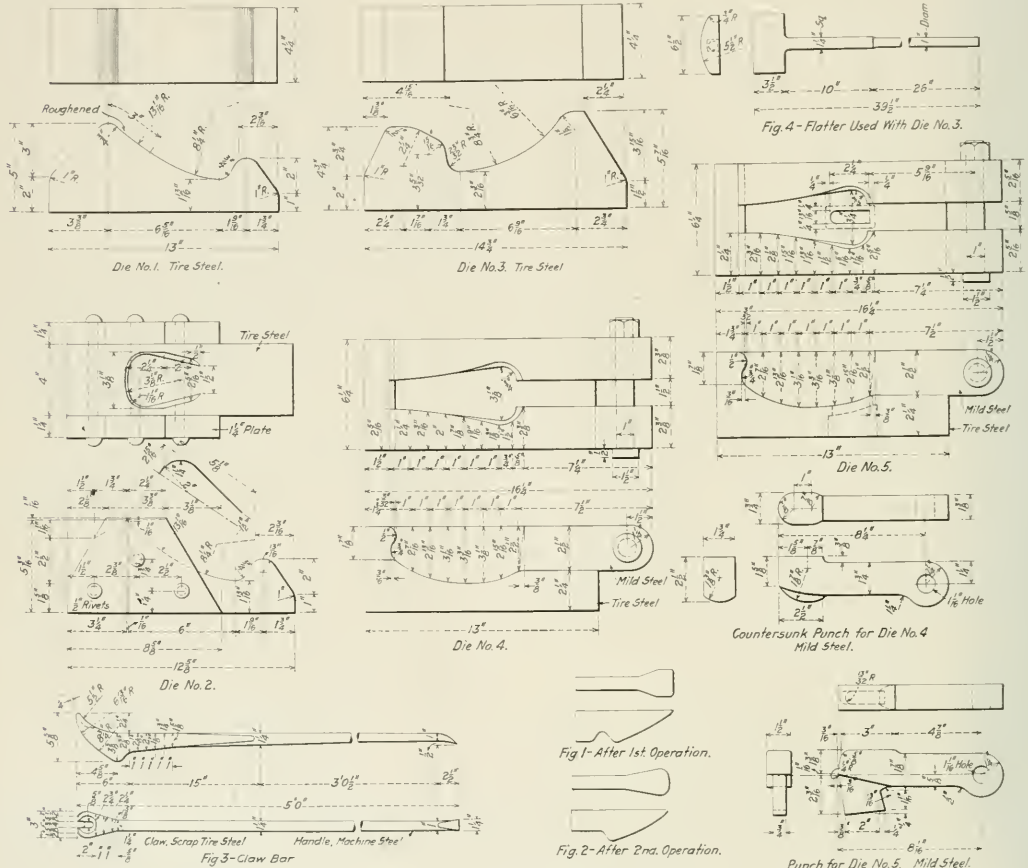

Dies Used In Making Claw Bars

nished the trackmen without informing them as to the change in material and our observations, covering a considerable period of time, have indicated very conclusively that the reclaimed bars are proving satisfactory in every respect.

The operation of making these bars, which are all formed under steam hammer, is as follows:

Operation 1.—Obtain a bar of scrap tire steel 1 1/2 in. by

Operations No. 4 and No. 5 can be performed in one heat, but it is not recommended as it is liable to injure the punches. The claw and the old handle from the discarded claw bar are then scarfed and welded together.

The dies themselves were made from scrap tire steel, except the top part of dies No. 4 and No. 5 and the punches which were made of mild steel.

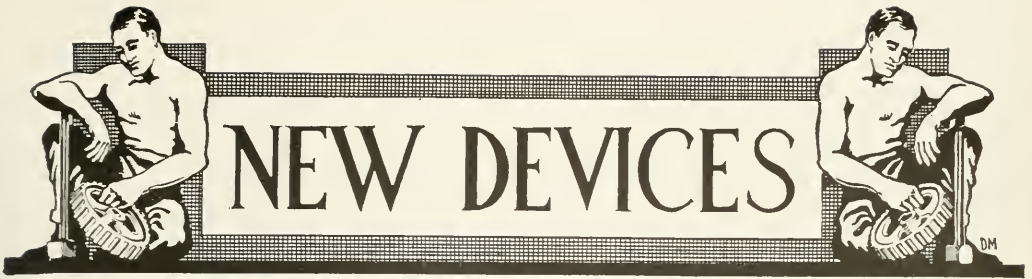

NEW DESIGNS OF BOILER TOOLS

A beading tool which differs radically from the type ordinarily used has been developed by William Kerr, boiler foreman of the Chicago & North Western, at Clinton, Ia. This device, an illustration of which appears below, has two blades with shoulders shaped to the outline of the bead on the tube. These blades are held in the body of the tool by a

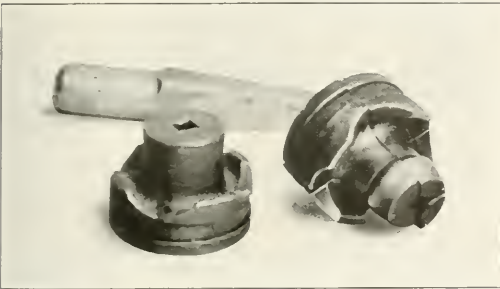

Projections on the Expander Sections Prevent Injury to the Tubes

rubber band and are separated slightly by a rubber block placed between them. The shank, which fits the air hammer, is made separate from the body. In operating the tool it is held in line with the tube and revolves while the air hammer is operating. It is claimed that tubes can be beaded in from 15 to 20 seconds with this device. The tool cannot be held at such an angle that the blades will injure the tube

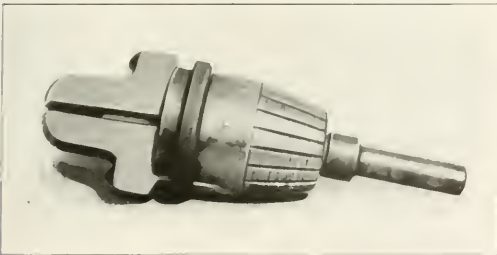

A Self-Aligning Beading Tool

sheets, as is often done with the common type of beading tool. By providing bodies of different sizes the same blades can be used for both the small tubes or for the larger superheater flues.

Another tool designed by Mr. Kerr is a new type of sectional expander. The straight expander is shown at the

right in the illustration and the Prosser expander at the left. It will be noted that both styles have projections at the outer edges of the sections. These bear against the flue sheet when the expander is in use so that the shoulder of the expander will not be forced against the projecting end of the tube when the pin is driven in. This prevents the weakening of the flue at this point and forcing the bead away from the sheet when the expander is used repeatedly. Both of these devices are handled by the Collis Company, Clinton, Iowa.

PORTABLE VISE STAND AND PIPE BENDER

A vise stand and pipe bender which is portable and can be used without being fastened in place has been put on the market by H. P. Martin & Sons, Owensboro, Ky. It is adapted for use wherever a stand is required on which pipes or conduits may be bent, threaded or cut.

The stand is made of No. 16 iron reinforced with mal-

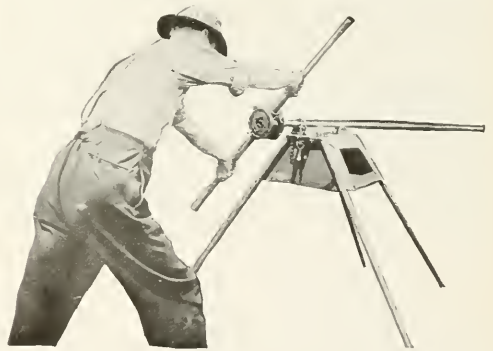

Martin Portable Vise in Use

leable castings. The legs are pieces of $\frac{3}{4}$ in. pipe and fit into pockets in the stand. Either a hinged pipe vise or a vise of the chain type can be furnished with the stand. On the side opposite the vise there is a special patented pipe bending fixture which also serves as a support for the pipes placed in the vise. The side braces provide a convenient place for tools.

The stand can be disassembled quickly and makes a compact bundle. It weighs only 45 lb. and can readily be moved from place to place. Though light in weight it is rigid and does not require fastening to the floor as do most vises of this type. The legs are arranged so that they are not in the way when short nipples are being threaded. Pipes of all sizes up to 2 in. can be handled on this stand. If

desired, any part of the complete outfit can be supplied separately. This device is now in use on several railroads.

LOCOMOTIVE FRONT END SPARK ARRESTER

A new type of locomotive spark arrester has been developed and patented for both anthracite and bituminous coal burning locomotives by I. A. Seiders, superintendent of motive power and rolling stock of the Philadelphia & Reading. During the past two and one-half years it has been applied to 474 locomotives, 390 of which have wide fireboxes and burn anthracite coal, and the remainder have narrow fireboxes and burn bituminous coal. It is claimed that this spark arrester will not appreciably reduce the steaming qualities of the locomotive and a statement has been made that by its use the fire claims have been reduced 40 per cent.

The sectional photograph shows the device applied to a locomotive with a superheater, and the drawing illustrates the application to a saturated steam locomotive. The principal features of this spark arrester consist of a "breaker plate" made up of a slotted plate fitted with deflecting veins, which is applied in line of the flue gases ahead of the front flue sheet. This breaker plate tends to break up the largest sparks before they strike the netting. The horizontal diaphragm table plate is perforated with 7/32-in. holes and the side sections are inclined, being attached to the sides of the smokebox. This type of diaphragm reduces the amount of resistance to the draft and adds to the self-cleaning characteristics of the front end. The horizontal table is made up of 1/8-in. material, being 26 in. square. It is perforated to permit of better entrainment of the gases without decreasing the size of the exhaust nozzle and rests on a flange at the top of the nozzle tip. The blower pipe is fitted into the exhaust nozzle below the table line.

exhaust. The plate around the steam pipes is so secured that it will not vibrate, opening up holes for sparks to pass through.

The joints in the netting are so made that no openings

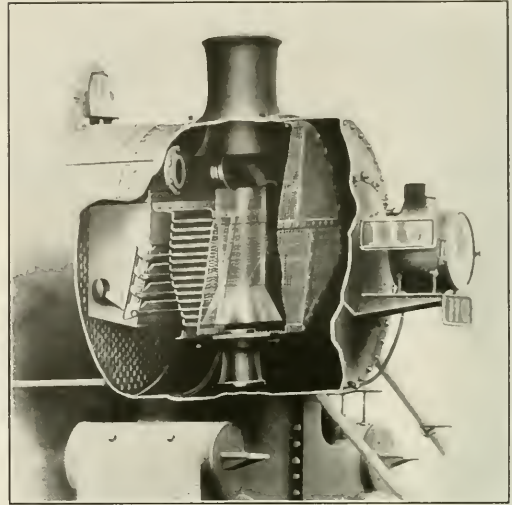

Application of Spark Arrester to a Superheater Locomotive

can occur to permit the passing of unduly large sparks. All nettings and plates are bolted at the side to a 2-in. angle iron which is riveted to the smokebox.

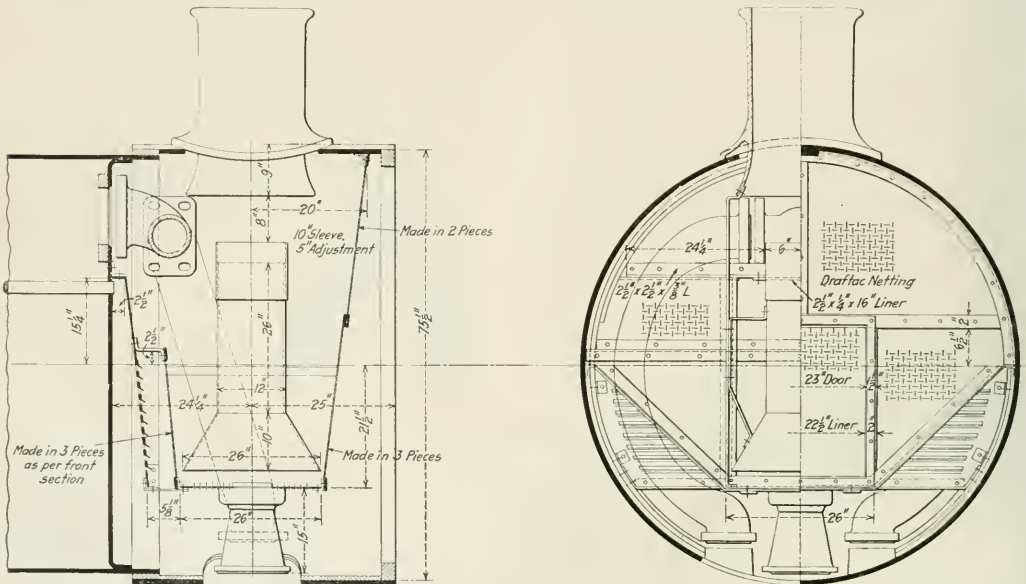

Arrangement of the Spark Arrester for Non-Superheater Locomotives

The side table plates are inclined, as shown in the illustration, to prevent the collection of cinders. The fine particles fall to the bottom of these plates on top of the perforated horizontal table and are carried out of the stack by the

The front netting and plates are arranged in separate parts with ample support at their intersections, as shown in the illustration. The center plates may be easily removed when it is necessary to work on the flues, making it un-

necessary to remove the entire front end netting or the table.

The spark breaker plate, located directly in front of the tube sheet and back of the front end netting, is secured to the flue sheet over the top row of flues under the T-pipe. It has 16 pressed steel openings 1 in. wide and pressed out 1/2 in. away from the plate for the full length of the plate. Its purpose is to break up the sparks, permitting only the finer particles to pass through the netting in front of it. The larger particles will travel to the front of the smokebox and in their passage be reduced sufficiently to pass through the netting.

The netting used with this device has an oblong opening 3 1/16 in. by 3 1/4 in. In the front end, shown in the drawing, the open area of the breaker plate is 462 sq. in. and the entire netting area has an opening of 1,607 sq. in. or 11.17 sq. ft.

Due to the large opening it will not be necessary to reduce the size of the nozzle to provide the proper draft. In this way it will provide greater economy in fuel.

This front end arrangement has reduced shop maintenance costs due to its self-cleaning qualities. It is simple in construction, strong and durable, and reduces the number of leaky joints in the netting commonly found on locomotives.

METHOD OF APPLYING OUTSIDE STEAM PIPES

An arrangement for applying outside steam pipes to locomotives with inside steam pipes and piston valves has been patented by the Locomotive Appliance Company, Chicago. The device is designed to overcome troubles due to leaky steam pipes and cracked cylinders. The parts required for its installation are now being sold by the company to railroads.

The device consists of a yoke casting for the valve chest

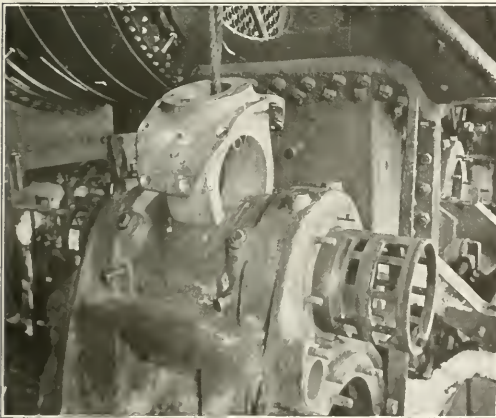

Fitting Yoke Casting to Steam Chest

pressure at that point. After the yoke and the valve chamber bushings have been applied it is the usual practice to fill the live steam passages in the cylinders with a mixture of cement and iron turnings. The outside steam pipes are applied in the usual manner, a gland being used where they pass through the smoke box, in order to secure a tight joint.

This device is used not only to reclaim cylinders but also to substitute outside for inside steam pipes. Some roads consider that the advantages to be derived from the change fully justify the cost on account of the large amount of trouble experienced due to leaks at the bottom joint on inside steam pipes, resulting in a waste of steam, inefficient combustion and loss of service from locomotives. One road that is now applying outside steam pipes to large numbers of engines found by testing inside steam pipes on locomotives in service that 90 per cent of them showed leaks at the bottom joints.

NIGHT LIGHTS FOR PULLMAN CARS

The Pullman Company has been experimenting for some time with various lighting arrangements designed to provide suitable illumination for the aisles of sleeping cars after the passengers have retired. A satisfactory installation has recently been developed and is now being applied to all new cars built and also to cars which pass through the shops for repairs.

It may be of interest to give a few details of the numerous installations which were tried before a method of lighting

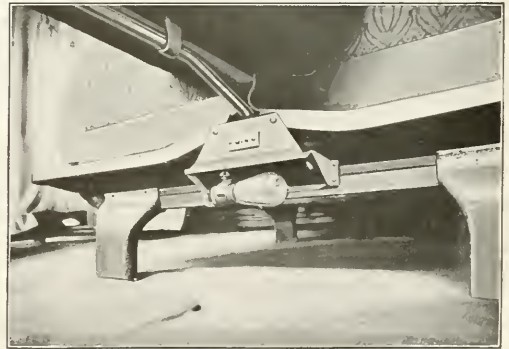

Arrangement of Aisle Light Under the Berth

was evolved that would fulfill all the requirements. In one of the experiments a light was placed at the bulkheads at the ends of the aisles and shaded with an amber glass, with a view to providing a non-glaring light to illuminate the aisle at night. This was found to be unsatisfactory as it lighted the end sections to some extent. An attempt to secure the same results by dimming the ceiling lights also proved a failure. An installation with lights under the seat ends was tried, but the light was found to be annoying to the occupants of the lower berths opposite the fixtures. This objection has now been overcome by shading the light with a green glass.

The lighting arrangement which has been adopted for illuminating the aisles consists of 15 watt, 32 volt, type S tungsten lamps in receptacles placed under the ends of alternate seats. As the ends of the aisle are illuminated by the lights at the bulkheads it is not necessary to provide lights under the single seats in the end sections. Every second seat end on each side of the car carries one of the lighting fixtures, which are placed alternately on opposite sides of the

and flanges to fit around the steam pipes where they pass through the smoke box. It is also necessary to provide steam pipes which will fit the outside connection on the steam chest, and valve chamber bushings long enough to extend into the yoke. In applying the device it is first necessary to cut the steam chest to receive the yoke. When placed in position the horizontal passage through this casting is directly in line with the valve chamber bushings. The yoke is then bored out and the bushings pressed in from both sides to make steam tight joints. It is not necessary to have the joint between the yoke and the steam chest tight as there is no

car. Thus a 12 compartment car has 5 aisle lights and a 16 compartment car has 7.

The aisle lights are connected to one side of the circuit which carries the current for the reading lights. By using a common return for these circuits there is a considerable saving in wire and still both sets of lights can be controlled independently at the main switchboard. Separate switches are used for the lights on the right and left sides of the car. The wires for the aisle lights are run between the inner and outer panels of the car side. Junction boxes are placed in the conduit at the seats carrying the aisle lights and short conduits are run under the seat rails to the aisle seat ends.

The fixture, which is attached to the aisle seat end and the seat rail, is pressed out of sheet steel. The base carries a small switch of the push button type which makes it possible to control each light individually. The lamp is placed in the fixture in a horizontal position, being held in place by a



Location of Aisle Light for Pullman Cars

plain Edison type socket secured by a spring clip. The casing around the light, like the base, is of pressed steel. In one side it carries a green glass which throws a subdued light over the floor. The connections are dust tight and with the exception of the green glass, which can readily be reached from the aisle, the parts will require cleaning at infrequent intervals. As will be seen from the illustrations all parts of the fixtures are easily accessible when the seats are removed and in case it becomes necessary to replace a lamp or any other part it can be done with little difficulty.

The Pullman Company is now planning to install fixtures similar to those used on the berths at the steps, to provide illumination for the treads. Clear glass, instead of green glass, will be used in these fixtures. Applications have been made by the Pullman Company for patents to cover the principal features of this system of lighting.

GOGGLES WITH NON-BREAKABLE LENSES

Safety goggles with lenses made of a new type of non-breakable glass, known as Resistal, are now being made by Strauss & Buegeleisen, 37 Warren St., New York. These goggles are adapted for use in shops and also by engineers and firemen.

The unusual properties of Resistal glass, which can be cracked but not actually broken, even by a heavy blow, are due to its unique construction. It is made up of two layers of optical glass with a layer of celluloid between, the three parts being welded into a solid mass. Even if the glass is cracked there is no tendency for it to splinter off. Unlike celluloid, Resistal cannot be scratched and is not inflam-

mable. It is not affected by water or temperature changes. Moisture will not condense on the surfaces of these lenses and cause them to cloud up.

Goggles with the Resistal crystals can be furnished with



A New Type of Lens With Many Points of Excellence

either flat or curved lenses and in plain, amber or euphos colors. This type of glass has been used in goggles for aviators and also for military gas masks.

ASHTON MASTER PILOT GAGES

A new pressure gage of especial interest to power plant owners is being introduced, by the Ashton Valve Company, Boston, Mass.

It is designed to be hung in the center of the room, and an unusual feature is the double dial arrangement, illumi-

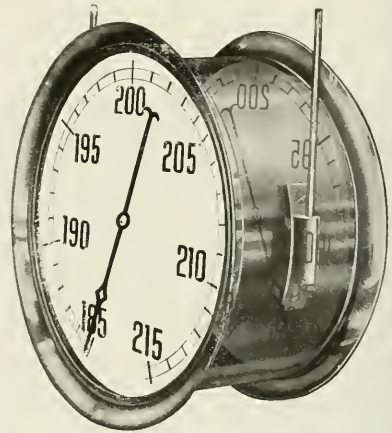

Double Dial Illuminated Gage

nated from the inside, which allows the pressure to be noted from a distance in either direction.

The dials, being graduated to show only 15 lb. above and below the working pressure, admit of wide divisions and large figures, so the slightest variation of pressure is noticeable and this insures close firing and economy of fuel.

NEW ROLLING STOCK FOR PANAMA RAILWAY.—By proclamation dated September 27, 1907, the President of Chile has set aside for the use of the Antofagasta-La Paz Railway the sum of 1,200,000 pesos (2,400,000). This fund is to be used in the purchase of 100 freight cars of 25-tons capacity, and 3 Mallet locomotives. Persons interested may secure further information from the Ministry of Railways, Santiago, Chile.—*Commercial Report.*

Railway Mechanical Engineer

(Formerly the RAILWAY AGE GAZETTE, MECHANICAL EDITION
with which the AMERICAN ENGINEER was incorporated)

PUBLISHED ON THE FIRST THURSDAY OF EVERY MONTH BY THE
SIMMONS-BOARDMAN PUBLISHING COMPANY

EDWARD A. SIMMONS, *President* L. B. SHERMAN, *Vice-President*
HENRY LEE, *Vice-President and Treasurer* M. H. WIUM, *Secretary*
WOOLWORTH BUILDING, NEW YORK, N. Y.
F. H. THOMPSON, *Business Manager, Chicago.*

Chicago: Transportation Bldg. Cleveland: Citizens' Bldg.
Washington: Home Life Bldg.
London: Queen Anne's Chambers, Westminster.

ROY V. WRIGHT, *Editor*

R. E. THAYER, *Managing Editor*

C. B. PECK, *Associate Editor* E. L. WOODWARD, *Associate Editor*
A. F. STUEBING, *Associate Editor* C. W. FOSS, *Associate Editor*

Entered at the Post Office at New York, N. Y., as mail matter of the second class.

Repeat of the Valuation Act, under which the Interstate Commerce Commission is making a valuation of railway property, is the object of a bill which has been introduced in Congress by Senator King of Utah. It is Senate bill No. 3530.

By a fire in the yards of the Boston & Maine at Boston, Mass., on January 6, 50 passenger cars, three mail cars, six freight cars and four small shops were destroyed, together with the North-Station power-plant; the estimated loss is \$200,000.

The shopmen of 29 roads west of Chicago have laid before the director-general of railroads a request for better pay and for an eight-hour day; also for overtime rates for work done on Sundays and holidays. They want a maximum rate of \$6 a day and a minimum of \$3.50 for all shopmen, except carmen. The carmen want a maximum of \$5 a day.

"The International Car and Locomotive Workers and Railway Mechanics," also called the Brotherhood of Railway Mechanics, is an organization, real or imaginary, which the Merchants' Association of New York City has investigated and has not been able to locate. Members of the association are cautioned to be certain of the facts before contributing to solicitors representing these "mechanics."

Government to Mobilize Labor

The United States Department of Labor has recently reorganized its employment service for the purpose of conducting a campaign for the mobilization of labor. This is to meet the greatly increased demand of war industries and one of the announced objects is to furnish 250,000 men for transportation service. The employment office formerly under the jurisdiction of the commissioner-general of immigration has been turned over to the United States employment service under the direction of John B. Densmore; and the Secretary of Labor has appointed a special advisory council, including representatives both of employers and of employees, with John Lind, former governor of Minnesota, as chairman. This advisory council is to direct the campaign for co-ordinating the supply and the demand of all labor.

"The labor administrator and his advisory council," says Mr. Wilson, "will at once take in hand the questions of

Subscriptions, including the eight daily editions of the *Railway Age* published in June in connection with the annual conventions of the Master Car Builders' and American Railway Master Mechanics' Associations, payable in advance and postage free: United States, Canada and Mexico, \$2.00 a year; Foreign Countries (excepting daily editions), \$3.00 a year; Single Copy, 20 cents.

WE GUARANTEE, that of this issue 8,100 copies were printed; that of these 8,100 copies 7,152 were mailed to regular paid subscribers, 108 were provided for counter and news companies' sales, 323 were mailed to advertisers, 162 were mailed to exchanges and correspondents, and 355 were provided for new subscriptions, samples, copies lost in the mail and office use; that the total copies printed this year to date were 16,800, an average of 8,400 copies a month.

The RAILWAY MECHANICAL ENGINEER is a member of the Associated Business Papers (A. B. P.) and the Audit Bureau of Circulations (A. B. C.).

standardization of labor policies; will consider labor dilution and training; priority demands; the adjustment of disputes and the safeguarding of employment. The advisory council will study all phases of the problem, make recommendation and plans for additional machinery and supervise their execution."

Arrangements are being made for the early transportation of 50,000 common laborers to the United States from Porto Rico. As soon as vessels are available 60,000 others will be brought from Porto Rico and the Virgin Islands, sufficient, it is hoped, to take care of the shortage in the domestic supply of railroad and agricultural workers. Director-General McAdoo has asked the employment service to assist in supplying the railroads with labor for maintenance of way and for shop work.

More Railway Honor Men

Additional data concerning the number of railroad men now with the colors have come to hand since the publication of the Railroad "Roll of Honor" appearing on page 11 of the *Railway Mechanical Engineer* for January. Returns have been received from 126 roads representing 209,463 operated miles. The number of railway officers and employees of these lines now holding commissions in the army or navy number 1,482. Of the mechanical department, W. B. Blanchford, machinist of the Baltimore & Ohio, has received a commission as captain in the regular army, and E. H. Sheeran, general foreman of the Florida East Coast, is a captain of the Railway Engineers.

Malicious Misrepresentation

Many railroad men were much surprised at a statement which was widely printed in newspapers, and which was attributed to Commissioner C. C. McChord, that: "Gross negligence of railroads under private management in giving proper care to locomotives is a principal cause of the present freight congestion." Commissioner McChord was quoted as announcing that "hundreds of locomotives which are sorely needed in the present emergency are idle in shops and round-houses, frozen through neglect or lacking repairs which might have been made if proper forethought had been given by local railway officials."

Mr. McChord did not make such a statement. A Wash-

ington newspaper correspondent apparently drew the inference after looking over a copy of Commissioner McChord's daily congestion statement.

Buy Thrift Stamps with Liberty Bond Interest

"Apply the interest from your Liberty bonds to the purchase of government Thrift stamps." This suggestion has been advanced by President William Sproule to all officers and employees of the Southern Pacific's Pacific System. The suggestion came in the form of a circular which is to be widely distributed. Announcement is made that the company will offer the security of its own vaults to all employees who desire to protect their Liberty bonds and will collect in their behalf the interest as it accrues and either remit same or invest it in government savings stamps as the owner desires.

Locomotive and Freight Car Orders in January

The past two or three weeks have seen a sharp revival in the locomotive market but with little or no improvement in the case of freight cars.

During the month of January orders were reported for the following equipment:

	Locomotives	Freight Cars	Passenger Cars
Domestic	168	468	10
Foreign	29	7	7
Total	197	474	17

The important locomotive orders included in the 197 mentioned were as follows:

Chesapeake & Ohio.....	15	2-6-2	American
	10	0-10-0	American
Chilean State Rys.....	20	Mikado	American
Delaware & Hudson.....	20	Consolidation	American
Delaware, Lackawanna & Western.....	15	Mikado	American
Hocking Valley.....	20	2-6-6-2	American
Maine Central.....	8	Ten-wheel	American
Minneapolis & St. Louis.....	15	Mikado	American
Missouri, Kansas & Texas.....	25	Mikado	American
Philadelphia & Reading.....	15	Company shops
Rhodesian Rys.....	0	Mountain	American

Railway Regiments' Tobacco Fund

Contributors to the Railway Regiments' Tobacco Fund will be interested in a letter from Fred A. Preston, secretary and treasurer of the P. & M. Company, Chicago, now a captain in the regular army in France. He was in a hospital for a month with the measles, and after he came out he wrote a letter to Fred A. Poor, president of the P. & M. Company, in which he said:

"I had occasion while at the hospital to see what sending tobacco to the soldiers means. There were sixty privates with the measles quarantined in a separate building and they were the most cheerless lot of men I ever saw, with no clothes of their own and nothing to smoke. They were actually sick, not from measles but from pure lonesomeness. After they had been there six days the Y. M. C. A. brought around about 500 bags of Bull Durham and the whole character of the place changed in a flash. I have never seen anything which gave so much pleasure and those boys were well in an hour, and left the hospital the next day!

"There is nothing so welcome as Bull Durham with plenty of papers and matches. The latter are especially scarce. Send the tobacco in the large size bags. Before long I shall have the chance to see some of the soldiers who are receiving your tobacco. I will write you what they say; but I know now what it will be."

Further contributions have been received from the following companies:

Detroit Graphite Company, Detroit, Mich.....	\$3 a month for 12 months
Mt. Vernon B-Edge Company, Mt. Vernon, Ohio.....	10 a month for 12 months
Ohio Steel Foundry, Lima, Ohio.....	10 a month for 12 months

A check for \$295.94 has been received from E. A. Stillman, acting chairman of the House Committee of the Machinery Club of New York, as the Railway Regiments' Tobacco Fund proportion of one-third of the net profits of the cigar department of the club, for the month of December.

MEETINGS AND CONVENTIONS

Canadian Railway Club.—A special smoker and concert will be held by the Canadian Railway Club on February 22 in the Windsor Hotel, Montreal, Que.

Air Brake Association.—The executive committee of the Air Brake Association at a recent meeting decided to hold the 1918 annual convention, the announcement stating that "Existing war conditions were finally believed by your executive committee to be a compelling force to hold a convention." The meeting will be held in Cleveland on May 7 to 10.

The following list gives names of secretaries, dates of next or regular meetings and places of meeting of mechanical associations:

- AIR BRAKE ASSOCIATION.—F. M. Nellis, Room 3014, 165 Broadway, New York City. Convention May 7 to 10, Cleveland, Ohio.
- AMERICAN RAILWAY MASTER TINNERS', COFFERSMITHS' AND PIPEFITTERS' ASSOCIATION.—O. E. Schlink, 485 W. Fifth St., Peru, Ind. Convention postponed.
- AMERICAN RAILWAY MASTER MECHANICS' ASSOCIATION.—J. W. Taylor, Karpen Bldg., Chicago. Convention postponed.
- AMERICAN RAILWAY TOOL FOREMEN'S ASSOCIATION.—R. D. Fletcher, Belt Railway, Chicago. Convention postponed.
- AMERICAN SOCIETY FOR TESTING MATERIALS.—Prof. E. Marburg, University of Pennsylvania, Philadelphia, Pa.
- AMERICAN SOCIETY OF MECHANICAL ENGINEERS.—Calvin W. Rice, 29 W. Thirty-ninth St., New York.
- ASSOCIATION OF RAILWAY ELECTRICAL ENGINEERS.—Joseph A. Andreuccetti, C. & N. W., Room 411, C. & N. W. Station, Chicago.
- CAR FOREMEN'S ASSOCIATION OF CHICAGO.—Vator Kline, 841 Lawlor Ave., Chicago. Second Monday in month, except June, July and August, Hotel Mottison, Chicago.
- CHIEF INTERCHANGE CAR INSPECTORS' AND CAR FOREMEN'S ASSOCIATION.—W. R. McMunn, New York Central, Albany, N. Y. Convention postponed.
- INTERNATIONAL RAILROAD MASTER BLACKSMITHS' ASSOCIATION.—A. L. Woodworth, C. H. & D., Lima, Ohio. Convention postponed.
- INTERNATIONAL RAILWAY FUEL ASSOCIATION.—J. G. Crawford, 547 W. Jackson Blvd., Chicago.
- INTERNATIONAL RAILWAY GENERAL FOREMEN'S ASSOCIATION.—William Hall, 1126 W. Broadway, Winona, Minn. Convention postponed.
- MASTER POLEMAKERS' ASSOCIATION.—Harty D. Vought, 95 Liberty St., New York. Convention postponed.
- MASTER CAR BUILDEES' ASSOCIATION.—J. W. Taylor, Karpen Bldg., Chicago. Convention postponed.
- MASTER CAR AND LOCOMOTIVE PAINTERS' ASSOCIATION OF U. S. AND CANADA.—A. P. Dabe, P. & M., Reading, Mass. Convention postponed.
- NIAGARA FRONTIER CAR MEN'S ASSOCIATION.—E. N. Frankenberger, 623 Brisbane Bldg., Buffalo, N. Y. Meetings, first Wednesday in month, New York Telephone Bldg., Buffalo, N. Y.
- RAILWAY STOREKEEPERS' ASSOCIATION.—J. P. Murphy, Box C, Collinwood, Ohio. Convention postponed.
- TRAVELING ENGINEERS' ASSOCIATION.—W. O. Thompson, N. Y. C. R. R., Cleveland, Ohio. Next meeting, September 16, 1918, Chicago.

RAILROAD CLUB MEETINGS

Club	Next Meeting	Title of Paper	Author	Secretary	Address
Canadian	Feb. 12, 1918	Architecture and Building as Applied to Railway Work	C. Gordon Mitchell..	James Powell....	P. O. Box 7, St. Lambert, Que.
Central	Mar. 8, 1918	Terminal Handling of Locomotives; Annual Report of Committee on Interchange Rules	Frank C. Pickard...	Harry D. Vought...	95 Liberty St., New York.
Cincinnati	Feb. 12, 1918	Talk on Duties of Railway Employees.....	Hon. Judson Harmon..	H. Bouet	101 Carew Bldg., Cincinnati, Ohio.
New England.....	Feb. 12, 1918	Chilled Iron Wheels.....	F. K. Vial.....	W. E. Cade, Jr....	683 Atlantic Ave., Boston, Mass.
New York.....	Feb. 15, 1918	Possibilities of Reducing Effect of Moving Parts of Locomotives on Engines and Tracks	E. W. Strong.....	Harry D. Vought...	95 Liberty St., New York.
Pittsburgh	Feb. 22, 1918	J. B. Anderson.....	307 Penn. Station, Pittsburgh, Pa.
St. Louis.....	Feb. 8, 1918	B. W. Franchenthal..	Union Station, St. Louis, Mo.
Western.....	Feb. 18, 1918	Joseph W. Taylor...	1112 Karpen Building, Chicago.

PERSONAL MENTION

GENERAL

JOSEPH OPLA, general foreman of the Chicago, Milwaukee & St. Paul at Austin, Minn., has been appointed general inspector, with the same headquarters.

CHARLES C. RICHARDSON, whose appointment as assistant to the superintendent of motive power of the Bessemer & Lake Erie was announced in the January issue of the *Railway Mechanical Engineer*, was born at Junction City, Kansas, on September 18, 1873.



C. C. Richardson

After graduating from the Greenville (Pa.) High School he became a painter's helper in May, 1890, with the Pittsburgh, Shenango & Lake Erie, now a part of the Bessemer & Lake Erie. In July, 1890, he was made a locomotive fireman, and in December, 1892, storekeeper. In January, 1893, he became a clerk, later in the same year timekeeper, and in August, 1894, chief

clerk. He held this position until he was recently given charge of the office, accounting and stores department with the title of assistant to the superintendent of motive power.

DANIEL SINCLAIR, road foreman of engines of the Northern Pacific, with office at Glendive, Mont., has been appointed fuel supervisor, with headquarters at Glendive.

J. E. BJORKHOLM, traveling engineer of the Chicago, Milwaukee & St. Paul, with headquarters at Milwaukee, Wis., has been appointed division master mechanic of the Chicago terminal, with office at Chicago.

JOSEPH BODENBERGER, traveling engineer of the Chicago, Milwaukee & St. Paul, with headquarters at Aberdeen, S. D., has been appointed division master mechanic of the Hastings and Dakota division, with the same headquarters.

L. F. COUCH has been appointed master mechanic of the Memphis, Dallas & Gulf with office at Nashville, Ark., succeeding F. J. Sears.

ALBERT J. DAVIS, whose appointment as master mechanic of the Allegheny and Bradford divisions of the Erie Railroad, with headquarters at Hornell, N. Y., was noted in these columns last month, was born at Meadville, Pa., in 1876. After leaving high school he entered the employ of the Erie Railroad as an engine wiper in 1896, subsequently serving a machinist apprenticeship. He was afterwards a machinist, erecting gang foreman and general foreman at Salamanca, N. Y., being later transferred to Hornell, N. Y., as general foreman. He was subsequently promoted to assistant master mechanic, so continuing until he was recently appointed master mechanic.

H. G. DIMMITT, district master mechanic on the River and Iowa Minnesota divisions of the Chicago, Milwaukee & St. Paul, has been appointed division master mechanic of the same divisions.

A. H. HACKFIELD has been appointed master mechanic and roadmaster of the Southwestern Railway with office at Archer City, Texas.

W. H. HART, assistant district master mechanic on the Superior division of the Chicago, Milwaukee & St. Paul, with office at Green Bay, Wis., has been promoted to division master mechanic with the same headquarters.

E. W. HARVEY has been appointed division master mechanic of the Illinois, and Racine and Southwestern division of the Chicago, Milwaukee & St. Paul, and the Rochelle & Southern line, with office at Savanna, Ill.

WILLIAM JOOST, roundhouse foreman at the Milwaukee shops of the Chicago, Milwaukee & St. Paul, has been promoted to master mechanic of the Milwaukee terminal and the Chicago and Milwaukee division, with office at Milwaukee shops, Wis.

G. P. KEMPF, district master mechanic on the Dubuque division of the Chicago, Milwaukee & St. Paul, with office at Dubuque, Iowa, has been appointed division master mechanic of the same division.

A. J. KLUMB, assistant district master mechanic of the Chicago, Milwaukee & St. Paul, with office at Milwaukee shops, has been appointed division master mechanic of the Prairie du Chien and Mineral Point division, with office at Madison, Wis.

T. S. MANCHESTER, general foreman of the Chicago, Milwaukee & St. Paul at Aberdeen, S. D., has been appointed traveling engineer, with the same headquarters.

G. J. MESSER, general car and locomotive foreman of the Chicago, Milwaukee & St. Paul, with headquarters at Minneapolis, Minn., has been appointed division master mechanic of the Sioux City and Dakota division, with headquarters at Sioux City, Iowa.

P. L. MULLEN, roundhouse foreman of the Chicago, Milwaukee & St. Paul at Sioux City, Iowa, has been appointed division master mechanic of the Southern Minnesota division, with office at Austin, Minn.

S. J. O'GAR, general car and locomotive foreman of the Chicago, Milwaukee & St. Paul, with headquarters at Ottumwa Junction, Iowa, has been appointed division master mechanic of the Kansas City division, with the same headquarters.

B. J. PEASLEY has been appointed mechanical superintendent of the St. Louis-Southwestern of Texas with office at Tyler, Tex.

M. F. SMITH, division master mechanic of the La Crosse and Wisconsin Valley division of the Chicago, Milwaukee & St. Paul, with office at Milwaukee shops, has been promoted to district master mechanic, with the same headquarters.

JOHN TURNER, assistant district master mechanic of the Twin City terminals of the Chicago, Milwaukee & St. Paul, with office at Minneapolis, Minn., has been appointed division master mechanic of the same division.

CAR DEPARTMENT

JOSEPH BENZINGER, for many years foreman for the Chicago, Milwaukee & St. Paul at the Milwaukee shops, has retired from railroad service.

OSCAR HANDLEY, formerly with the Vandalia Railroad at Vandalia, Ill., has been transferred to East St. Louis, Ill., as car inspector for the Pennsylvania Railroad.

R. A. KLEIST has been appointed car foreman of the Baltimore & Ohio at South Chicago, Ill., succeeding E. H. Mattingly assigned to other duties.

L. K. SILLCOX, mechanical engineer of the Illinois Central in charge of car work, has been appointed master car builder of the Chicago, Milwaukee & St. Paul, with headquarters at Milwaukee, Wis. He was born at Germantown, Pa., on April 30, 1886, and was educated at Trinity School, New York, and the Mechanical and Electrical Institute of Brussels. He entered railway service in 1903 as an apprentice in the High Bridge shops of the New York Central, leaving there in 1906 to go with the McSherry Manufacturing Company at Middletown, Ohio. He resigned from that company as assistant shop superintendent in 1909 to become shop engineer of the Canadian Car & Foundry Company at Montreal. He left his position with the latter company in 1912 to become chief draftsman of the Canadian Northern. In 1916 he was appointed mechanical engineer of the Illinois Central in charge of car work, from which position he resigned to accept the appointment noted above.



L. K. Sillcox

WILLIAM SNELL, district general car foreman of the Chicago, Milwaukee & St. Paul, with headquarters at Minneapolis, Minn., has been transferred to the newly created position of the same rank at the Chicago terminal.

T. TRACEY has been appointed foreman of car repairs at the East Buffalo car shops of the Erie Railroad.

SHOP AND ENGINEHOUSE

F. ARMSTRONG has been appointed foreman of the machine shop of the Wabash at Decatur, Ill., to succeed E. J. Hausbach.

H. EISELE, general foreman of the Wabash Railway at Decatur, Ill., has been appointed shop superintendent at Decatur, succeeding William Canavan, resigned to engage in other business.

W. H. FOSTER, engine despatcher of the Erie Railroad at Buffalo, N. Y., has been appointed roundhouse foreman.

E. J. HAUSBACH, machine shop foreman of the Wabash at Decatur, Ill., has been appointed general foreman, succeeding H. Eisele.

H. KOPPER, roundhouse foreman of the Erie Railroad at Buffalo, N. Y., has been appointed general foreman of the night force.

H. T. NOWELL, assistant superintendent of the Billerica (Mass.) shops of the Boston & Maine, has resigned to accept a position with the New York Air Brake Company at Watertown, N. Y., as superintendent of the shell department.

PURCHASING AND STOREKEEPING

N. B. COGGINS has been appointed division storekeeper of the Alabama Great Southern with office at Birmingham, Ala., succeeding D. A. Hickman, resigned to enter service of the United States Army.

A. GERRARD has been appointed material agent and assistant purchasing agent of the Missouri, Oklahoma & Gulf with office at Muskogee, Okla.

SUPPLY TRADE NOTES

P. M. Wagstaff has been appointed railroad representative for the Onondaga Steel Company, Inc., Syracuse, N. Y.

Peter L. Maher, business manager of the Eastern Car Company, Ltd., New Glasgow, Nova Scotia, has resigned his position and has returned to the United States.

S. D. Winger, formerly associated with the Prest-O-Lite Company, in charge of railroad sales, has been appointed general manager of the compressed acetylene department of the Oxweld Railway Service Company. He will be located at Chicago.

H. M. Aubrey, who has served in various capacities with the Quaker City Rubber Company and the H. W. Johns-Manville Company, has been appointed special packing representative of the Union Supply Company with headquarters at Chicago.

R. P. Lamont, president of the American Steel Foundries, with office at Chicago, has been commissioned a lieutenant-colonel by the War Department and appointed assistant chief of the procurement division of the ordnance department. He has reported to Washington for duty.

Frank Bartholomew, who has been erecting engineer for the Shaw Electric Crane Company for the past 20 years and who resigned his position with that company in December, 1917, has become associated with N. B. Payne in the Havemeyer building, 25 Church street, New York, specialist in electric cranes.

P. C. Gunion has been made advertising manager of the industrial bearings division of the Hyatt Roller Bearing Company, Newark, N. J. Mr. Gunion has been in the sales department of the Hyatt Company for two years. Just previous to his recent appointment he was manager of the Pittsburgh office.

Ralph F. Tillman has been elected vice-president of the Wine Railway Appliance Company, Toledo, Ohio, in charge of western sales with headquarters in Chicago, and W. F. Creman has been appointed assistant to the president of the company in charge of eastern sales with headquarters in Wilkes-Barre, Pa.

P. W. Page, formerly representative for the B. F. Goodrich Rubber Company, Akron, Ohio, in western Massachusetts and southern Vermont and more recently an ensign in the United States navy, was drowned recently off the coast of England when his seaplane became unmanageable and plunged into the sea.

At the meeting of the board of directors of the Union Steel Casting Company, Pittsburgh, Pa., C. C. Smith, formerly president of the company, was elected chairman of the board of directors. J. P. Allen, formerly vice-president, was elected president. The remaining officers of the company were re-elected as follows: S. H. Church, vice-president; G. W. Eisenbeis, treasurer; W. C. Eichenlaub, secretary, and J. B. Henry, general superintendent.

Recent promotions in the Pressed Steel Car Company's organization in the Pittsburgh district made J. H. Hackenburg purchasing agent, succeeding the late H. J. Gearhart. Mr. Hackenburg was formerly the assistant purchasing agent. H. B. Fisher and C. C. Clark have been appointed assistant purchasing agents of the company. W. C. Howe, formerly in charge of the Allegheny plant, becomes assistant to the vice-president. J. C. Ritchey has been appointed electrical engineer.

R. A. Van Houten, works manager of the Sellers Manufacturing Company, Chicago, has been appointed vice-president and general manager with the same headquarters. George M. Hogan, sales agent has also been appointed assistant secretary and W. H. Seigmund, cashier, has been appointed assistant treasurer. E. M. Kerwin, secretary-treasurer, has been granted a leave of absence to enter military service, having been commissioned a captain in the ordnance department and stationed at Washington, D. C.

Charles D. Jenks, who has been the active business executive of Edwin S. Woods & Co., Chicago, has severed his connection with that concern, having been elected president and

a director of the Damascus Brake Beam Company, with headquarters in Cleveland, Ohio. He was formerly in the operating and sales department of the Pressed Steel Car Company at Pittsburgh, Pa., and Chicago, and western sales manager for the Standard Coupler Company, leaving the latter concern in 1912 to go with Edwin S. Woods & Co. In his new position as president of the Damascus Brake Beam Company he will assume the active management of the operation and sales department.

Ralph C. Davison, for the past six years associated with the American Mason Safety Tread Company, New York, in a selling and engineering capacity, has resigned his position and directorship with the above company to engage in a broader and more active field with the American Abrasive Metals Company, makers of Feralun safety treads and anti-slip surfaces. Mr. Davison, through his connection with the Concrete Association of America, has a large acquaintance among architects and contractors.

Frank W. Hall has been appointed commercial manager of the Sprague Electric Works of the General Electric Company. With the exception of a short period, Mr. Hall has been connected with the Sprague Works continuously for 22 years in various engineering and sales capacities, and for the three years prior to his present appointment occupied the position of sales manager. D. C. Durland, former executive head of the Sprague Electric Works, has resigned to become president of the Mitchell Motors Co., Inc.

Waldo H. Marshall, formerly president of the American Locomotive Company, and now associated with J. P. Morgan & Co., has been appointed assistant chief of the Division of Production of the Ordnance Department. Mr. Marshall was on the staff of Edward R. Stettinius (now surveyor general of supplies in the War Department) in the munitions department of J. P. Morgan & Co. Born in 1864, Mr. Marshall began his business life as a railroad man. He became assistant superintendent of motive power for the Chicago & North Western in 1897; was appointed superintendent of motive power for the Lake Shore & Michigan Southern in 1899; was made general superintendent of that road in 1902, and general manager in 1903, his jurisdiction extending also over the Lake Erie & Western and the Indiana, Illinois & Iowa. In 1906, he was elected president of the American Locomotive Company.

Milton Rupert was recently elected vice-president and assistant treasurer of the R. D. Nuttall Company, of Pittsburgh, Pa., manufacturers of gears, pinions and trolleys. Mr. Rupert has been with the Nuttall Company since March 4, 1893, holding various positions. In 1903 he was appointed head of the general offices, being directly in touch with all office matters and also manufacturing operations. During the latter part of this period Mr. Rupert was assistant to president and general manager. In his new position, Mr. Rupert will have charge of sales and manufacturing activities.

Charles V. Eades, who recently resigned as sales manager and engineer of the asphalt product department of the Standard Asphalt & Rubber Company, Chicago, announces the establishment of the Mineral Rubber Products Company, with offices at 280 Madison avenue, New York City. The company will handle materials and will contract for floors, waterproofing, insulation, expansion specialties, protective coatings, etc., as well as represent other well-known manufacturers. One of the special products which this company has put on the market is a moisture-proof concrete block, designed by Mr. Eades.

Guy E. Tripp, of New York, heretofore chairman of the Westinghouse Electric & Manufacturing Company, has been appointed by the War Department, with the rank of colonel,

as chief of the production division of the ordnance department entrusted with the task of supervising and stimulating the production of all ordnance supplies.

The appointment of Mr. Tripp is one of the important steps in the reorganization of the ordnance bureau, announced recently by its chief, General Crozier.

Mr. Tripp was selected because of his experience in the manufacture of munitions of all kinds, the Westinghouse company having obtained large contracts

from the British and Russian governments immediately on the outbreak of the European war. Mr. Tripp is credited with bringing to the department the highest obtainable type of experience and ability to insure speedy and careful production of munitions. The board of directors of the Westinghouse company has given him a leave of absence for the duration of the war.

Cameron C. Smith, chairman of the board of the Union Steel Casting Company, Pittsburgh, Pa., was on January 15 appointed Major Ordnance Reserve Corps, and has been assigned to the Production Department, Carriage Division of the Ordnance Department of the U. S. Army, with headquarters in Washington. Mr. Smith was born in Clinton township, Butler county, Pa., April 2, 1861. His first position was as stenographer in the office of Wilson Walker & Co., iron and steel manufacturers of Pittsburgh, Pa. He was with them ten years, during which time it was merged into the Carnegie, Phipps & Co., and then into the Carnegie Steel Company. He left the employ of the Carnegie Steel Company in 1893, and accepted a position with the Reliance Steel Casting Co., of Pittsburgh, being with them six years, when in 1899 he withdrew to organize the Union Steel Casting Company, of Pittsburgh, Pa. He was secretary and gen-



C. D. Jenks



Guy E. Tripp

eral manager during the first year of the existence of the Union Steel Casting Company, and in 1900 was elected president, which position he has held until January 26, 1918, when he was elected chairman of the board of directors.

Frank J. Foley, formerly manager of the mining department of the Westinghouse Electric & Manufacturing Company, on January 1, became connected with the Edison Storage Battery Company, Orange, N. J., as manager of the mining and traction department, with headquarters at the main office in Orange. During the two years Mr. Foley was connected with the New York City service department of the Westinghouse Electric & Manufacturing Company, he helped install the original multiple unit control on the Brooklyn Rapid Transit system, helped install the switchboards and turbines in the Kent avenue power station of the Brooklyn Rapid Transit, and the turbo-generator unit at the Waterside station of the Consolidated Gas Company, New York. He then became connected with the East Pittsburgh plant of the Westinghouse Electric & Manufacturing Company, and after attending that company's engineering sales school for a year, was associated with the industrial sales department, going into the mining section in 1910, in which position he had occasion to handle electrical equipment for mines, including storage battery and trolley locomotives. In 1915 Mr. Foley was promoted to manager of the mining section.

W. H. Lovekin has been appointed assistant to the president of the Locomotive Feed Water Heater Company. Mr. Lovekin has been with the company since June, 1916. He was born in Philadelphia, Pa., and received his education in the public schools of that place, Haverford Preparatory School and Princeton University. He started his business career in the banking house of the Logan Trust Company, of Philadelphia. Later he accepted a position on the staff of the Bureau of Municipal Research of Philadelphia. On leaving the Bureau of Municipal Research he entered the sales department of R. J. Crozier & Co., of Philadelphia, where, because of special qualifications, he was shortly assigned to the railroad field. This position as sales representative in the railroad field brought him into intimate contact with railroad men. On June 1, 1916, he entered the service of the Locomotive Feed Water Heater Company as special representative. In this capacity he was intimately connected with the development of feed water heaters for locomotives and ships. In April of this year he was made assistant to vice-president, from which position he is now promoted.

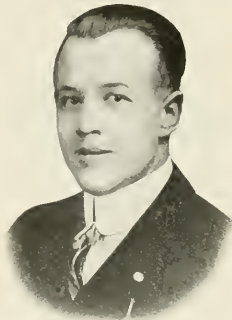

W. H. Lovekin

Frank Fouse has been appointed works manager of the Marsh Refrigerator Service Company with office at Milwaukee, Wis. He entered the service of the Pennsylvania in 1888. From 1896 to 1901 he was with the Pressed Steel Car Company at Pittsburgh, Pa.; from 1901 to 1908 with the Pittsburgh Testing Laboratory, and in the latter year he entered the service of the United Fruit Company as general foreman of the car department at Costa Rica.

CATALOGUES

BELT PULLEYS.—The American Pulley Company, Philadelphia, Pa., has recently published an instructive booklet on "Getting Maximum Pulley Efficiency." It contains an explanation of the power losses due to belt slip and a comparison of various pulley tests. The advantages of split steel pulley construction are plainly indicated.

SMOOTH-ON SPECIALTIES.—A new edition of the instruction book published by the Smooth-On Manufacturing Company, Jersey City, N. J., has recently been issued for free distribution. In addition to information regarding the use of Smooth-On iron cement, the booklet contains a list of the standard sizes of Smooth-On coated corrugated gaskets for flanged pipes of sizes from 2 in. to 26 in.

LATHE AND DRILL CHUCKS.—The Skinner Chuck Company, New Britain, Conn., has issued a very complete catalogue and price list of their products. All kinds of independent, universal and combination chucks are illustrated and the price for each different size is given. Planer chucks with either a square or swivel base and several different styles of drill chucks are also shown.

DIRECT CURRENT DYNAMOS.—The second of a series of catalogues of industrial motors has just been distributed by the Westinghouse Electric and Manufacturing Company of East Pittsburgh, Pa. This is known as Catalogue 30 and covers the company's complete line of direct current motors and generators for industrial service. After giving considerable general information regarding the ordering, classification and selection of direct current motors the catalogue shows the rating and dimensions of different types of motors used in reversing planer equipment, machine head stock equipment and arc welding motor generator sets.

ELECTRIC WELDING OUTFITS.—An interesting booklet on Electric Welding has been recently issued by the Wilson Welder & Metals Company, New York City. It is carefully arranged and contains in detail the development of the Wilson system in the electric welding field. A complete illustration and description of the apparatus is given and the advantages of independent control and constant temperatures are pointed out. Emphasis is also laid on the importance of the metal used in welding, and the claim is made that tests on electric welded joints in boiler steel plate show an efficiency of 100 per cent. The back of the book contains some useful tables and information and is valuable for reference.

BAKELITE MICARTA-D GEARS AND PINIONS.—The Westinghouse Electric & Manufacturing Company, East Pittsburgh, Pa., has recently issued a booklet describing the material and the methods of using Bakelite Micarta-D gears and pinions. Bakelite Micarta-D is a non-metallic material made up of a special heavy duck of uniform weave, thickness and tensile strength, bonded together with Bakelite by heating under very heavy pressure. The material is developed for use where silent operation is desirable and it is especially valuable because of the fact that it is not affected by water or oil, or by most acid or alkali solutions. The booklet gives a complete description of the properties of the material, the methods of working it, a complete outline of the methods of designing the gears and considerable data for the use of gear designers. The booklet is thoroughly illustrated with drawings and photographs and copies may be obtained upon request to the company's nearest branch office.

Railway Mechanical Engineer

Volume 92

March, 1918

No. 3

CONTENTS

EDITORIALS:

Car Repairs Under Government Control.....	127
Keeping Engines Off the Drop Pit.....	127
The Present Labor Situation.....	128
Adequate Facilities Make for Economy.....	128
The Standard Car.....	129
The Standardization of Locomotives.....	129
New Tools.....	130

GENERAL:

Intensive Locomotive Development.....	131
Activities of the Director-General.....	133
Locomotives for French Railways.....	136
Calculation of Boiler Stresses.....	139
Snow and Ice on the Pennsylvania.....	143
Supply Interests Write Mr. McAdoo.....	145
Honeycomb.....	146

CAR DEPARTMENT:

Development of the Steel Car.....	147
Improve the Condition of Cars.....	148
Michigan Central Refrigerator Car.....	149
Hot Boxes on Freight Cars.....	152
The Need of a Business Box Car.....	153
Run Repair or Transfer.....	155
Stresses in Bolts in Fulcrum Brackets.....	156

SHOP PRACTICE:

Air Compressor Table.....	159
Safety Air Compressor Oiling Step.....	160
Boiler Scale and Water Treatment.....	161
Spring Banding Machine.....	163
Gages for Driving Box Work.....	164
Principles of the Generation and Application of Heat in Steel Treating.....	164
Railway Shop Fans and Blowers.....	166
Polishing Ash Pans in France.....	166
Some Interesting Boiler Shop Equipment.....	167
Something New in Reamers.....	169
Group Insurance.....	170
Special Tool for Turning Up Air Pump Piston Rings.....	170
Making Cold Chisels.....	171

NEW DEVICES:

Sundstrand Tool Room Lathes.....	173
Paint Spraying System.....	174
A Portable Vise and Bench.....	175
A & Z Brake Beam Hanger.....	175
Carbocool—A New Fuel.....	175
A High Lift Industrial Truck.....	176
All Metal Steam Heat Connection for Cars.....	176

GENERAL NEWS:

Notes.....	177
Meetings and Conventions.....	178
Personal Mention.....	179
Supply Trade Notes.....	181

Car Repairing Under Government Control

The first order issued by Mr. McAdoo as Director General of Railroads contained the following instructions: "All transportation systems covered by procurement shall be operated as a national system of transportation, the common and national needs being in all instances held paramount to any actual or supposed corporate advantage." In order that the railroads might speed up their work, the government has guaranteed them a net income based on their incomes during the past three years.

Director General McAdoo's order and the provision of the railroad bill to guarantee the net income of the carriers have a very important bearing on the application of the M. C. B. rules. So far as the ultimate financial result is concerned, it would be the same if no repair cards were written. However, it would be inadvisable to stop this practice as the records will be needed and it will be difficult to put the rules into effect again when the government turns the roads back to their owners if no records are kept during the war.

The object of the M. C. B. rules is to place the charges for repairing cars where they rightly belong and this idea runs through all the work on foreign cars. Under the present circumstances the thought uppermost in the minds of those who repair the cars should be to secure the maximum of transportation efficiency, and to provide the greatest possible number of cars to handle the enormous traffic of war time.

There are various ways in which the car department can reduce the number of cars held for repairs. The M. C. B. Association has urged all the roads to repair cars whenever possible without holding them to secure material from

the owners. If by making wrong repairs a car can be put into serviceable condition this course should be followed. It is often possible to use some non-standard part and get the car back into service. One shop reports that it repaired 12,049 cars and ordered materials from the owners for only 11. It is important that minor repairs to cars be made as soon as they are required in order to prevent the development of more serious defects. There is a tendency to neglect minor repairs at this time. If the force of inspectors in the yards could be increased so that it would be possible for them to devote more time to making repairs, it would probably keep a great many cars off the repair track.

The object which should be foremost in the minds of the men in the car department should be to secure the maximum of transportation efficiency. The only way to do this is to repair both home and foreign cars with the least possible delay. It is to be hoped that the car situation will soon be improved by the delivery to the roads of large numbers of new cars. For the present it is important that the car men keep all the equipment they can in condition to do its part for the government.

Keeping Engines Off the Drop Pit

One of the large middle-west roads recently put two locomotives in the back shop for the first time in five years. These engines had not had the driving wheels removed during the period between shoppings. The fires had been taken off the wheel centers and turned to the proper contour and the driving box crown brasses and hub plates had been renewed without dropping the wheels.

When a locomotive is placed on the drop pit to have work

done on the driving boxes it is usually kept out of service for a considerable time. The heavy locomotives now in use require considerable work on the driving boxes. A pound in the crown brass is so serious a defect that it cannot be allowed to go without repairs, and the Federal locomotive inspection rules place rigid limits on the amount of lateral motion which is permissible. Under these conditions it is desirable to have crown brasses and hub plates which can be renewed without dropping the wheels.

Several roads are using removable crown brasses and hub plates, of various designs, with very satisfactory results. Judging from the reports of the performance of these devices they are not expensive to install, are reliable, cost little to maintain and effect large savings in the cost of making renewals. They have proven their worth and deserve the attention of mechanical department officers who are looking for means of securing more service from locomotives and reducing the cost of repairs.

The Present Labor Situation

The condition of power at the present time may be attributed, particularly in the east, to the severely cold weather and heavy snows that have been experienced this winter and to the general inefficiency of labor due to the cold weather and to the great number of changes in the shop forces. With the severe winter back of us, the main problem now is to increase the efficiency of the shop organizations. Never before has there been such a great need for efficient and adequate supervision. The railroads need foremen of strong executive ability to organize and in many cases, to reorganize the shop forces, that efficient work may be done.

The labor turnover during the past few months has been tremendous. New men are constantly coming to the railroads who are unfamiliar with the work. They must be taught and this requires supervision. They must be made to realize the importance of their work. This requires tact and diplomacy. The absentees from the shops must be brought to a minimum. Wages have been increased so that many workmen are satisfied to work but part time. Inducements must be made to keep the men on the job. A particularly good plan which has worked successfully at one point was recently brought to our attention. The day roundhouse men are given a bonus of 15 per cent at the end of the month if they have not been absent from work more than four days during the month without a sufficiently good excuse. The night men are granted a 20 per cent bonus if they meet the same conditions. While this plan has not been in effect for any great length of time, the short time it has been in use has shown a decrease of absentees to about eight per cent, which for this division point is a particularly good record.

It will be necessary to work overtime in order to recover the ground lost during the past two months. D. R. MacBain, of the New York Central Lines, testified before the Railroad Wage Commission that nine- and ten-hour shifts of the workers had been the salvation of his road during the winter. Other roads were not permitted to do this on account of the rigid restrictions placed on them by union labor. In the case of the Rock Island, existing schedules demand time and a half for the ninth hour and five hours pay for the tenth hour. In time of war, with the demand for power so great as it is now, labor unions can show their patriotism in no better way than by permitting any such absurd arrangement to be canceled. The railway shops must be operated to full capacity. They must be adequately supervised and controlled by men of strong executive ability. There is no excuse for such conditions to exist that it is possible for competent foremen to give up their jobs and return to subordinate positions in the shops because they can

make more money. Those roads that have permitted their forces to become thus disorganized have followed a short-sighted policy. The increased living expenses and the law of supply and demand have got to be met. Labor must have at its head competent leaders. They are worth their price.

Adequate Facilities Make for Economy

There is a road in the northern section of the United States that has an enviable reputation for good maintenance of brake cylinders, a part of the car equipment that too often is sadly neglected. Some time ago an officer of this road told how the equipment was maintained in such good condition. There was nothing startling about the methods employed; the proper facilities were furnished to the men and they were given comfortable quarters in which to work in cold or rainy weather. The disagreeable features of the work were eliminated and a great increase in the output of the men resulted. No doubt many who read the report regarded it as commonplace and failed to get the big lesson it contained: the economic value of comfortable working conditions.

The present labor situation furnishes the strongest argument that could be advanced for providing good facilities for the workers. The railroads a few years ago were able to get men to work under circumstances that were far from what might have been desired. Many of the men in authority realized that the conditions lowered the efficiency of the workers, but it was so hard to get the money required for improvements that were absolutely necessary, that they could not hope to be able to get capital to devote to furthering the welfare of the employees. The result is that in many places the recent congestion has made the working conditions such that few men will put up with them if they can find employment elsewhere.

The conditions in the average roundhouse make efficient work practically impossible, especially in cold weather. Very few roundhouses have an adequate heating system, or doors that will shut tightly and retain the heat. It is the rule rather than the exception to find pools of water standing on the floor and in the pits. Roundhouse work is hard and dirty at the best. In cold weather with the house full of steam, cold and dirty, no man can do even a fair amount of work. When the number of stalls is inadequate and locomotives must be repaired outside, as has been the case in many places during the past winter, the work that a man can do is reduced still more. Car repairing is done under conditions that are almost as bad as roundhouse work. When car men work under an open shed or with no protection from the cold or rain their production is sure to be low. Even where shops are provided the heating system is often so inadequate or the construction so poor, that in cold weather the men cannot work continuously but must stand around the stoves or radiators from time to time to get warm. Another feature that receives too little attention, is the lighting system. Unshaded lamps hung within the field of vision and often directly in front of the work furnish poor light and by fatiguing the eye reduce the output just as surely as does muscular fatigue. The dirt which settles on electric light globes in a short time reduces their illuminating efficiency more than 50 per cent; therefore frequent cleaning is necessary. In roundhouses cluster lights placed on movable stands are a great improvement over the ordinary extension light.

The conditions existing during the past winter could hardly have been foreseen, consequently allowances have been made for failure to maintain full production. Next winter the government will demand adequate transportation facilities. The railroads cannot furnish them without men to repair the locomotives and cars. If they hope to secure labor in competition with other industries they must see that they

provide decent working conditions. Larger and better equipped roundhouses and shops are urgently needed. The government will undertake to provide capital for the needs of the roads. In planning for the extensions necessary to meet the demands that will be made on them next winter the railroads should not neglect to take into account the fact that failure to provide comfortable working conditions is one of the biggest factors in reducing the efficiency of workers.

The Standard Car

The American roads are about to receive what they have long discussed, but never could agree on—a standard car. As indicated elsewhere in this issue, the Director-General has formed a committee with instructions to produce a standard car. The committee has been working industriously and it is believed that designs will soon be submitted. In contrast to the Director-General's committee appointed to investigate the feasibility of designing standard locomotives, the work of the car committee should be easy. A sub-committee of the American Railway Association has been working on the designs for standard cars for over three years. This sub-committee has gone over the situation thoroughly with the car builders and its deliberations and findings should be of material assistance to the government's car committee. It is sincerely to be hoped that it will avail itself to the fullest extent of the work of this sub-committee, as it is highly important that the operating and maintenance features be considered as well as the construction features.

There are differences in opinion as to how far the standardization should be carried. In this regard it is well to consider the reasons for designing standard equipment. Standardization is desirable from the standpoint of cheapness in first cost, adequate strength, interchangeability of parts, reduction of material to be carried in stock and the ease with which repairs may be made. All of these items have considerable weight on account of the number of cars built per year and the extent to which cars are interchanged from one road to another all over the country. These items considered alone, however, are liable to result in overstandardization, which, in a nation so progressive as ours, would be a short-sighted policy. Operating conditions the country over are changing from year to year and we have no assurance that they have yet become fixed. Vast changes have taken place in car construction during the past ten years, all of which have meant a saving in operating costs. There is no reason to believe that we have at the present time reached the height of perfection in car design. In fact, experimental equipment is now in operation which contains many features that will be of value to designers in the future.

The car building industry in the United States is peculiar to the extent that several manufacturers concentrate on building many of the detail parts going on to the car which are commonly known as specialties. These manufacturers have specialized on these particular parts, and due to competition have been forced to develop their products to the highest degree. The well-built modern car today is due largely to the progressiveness of these companies. None of them claim to have reached the zenith of perfection in their products and they are constantly seeking to still further improve them. Now, if by a too rigid program of standardization, these companies are forced to discontinue the manufacture of their products or have the incentive for still further improving them removed, there can be no question but that future development in car construction will be seriously handicapped. Furthermore, and particularly at this time, if these manufacturers of different appliances find it necessary on account of complete standardization of the car to discontinue business, the output of cars would be restricted.

At the present time the builders are equipped primarily to erect or assemble cars. They are not equipped to build the entire car. To provide them with the necessary facilities would take time. Either the capacity of their plants would have to be restricted in order to make these parts, or the size of the plants would have to be increased. Even then they would not have the highly specialized organizations for making such parts as is now found in the manufacturers of the special devices which concentrate on each individual part. Furthermore, the specialty manufacturers have provided themselves with materials for their particular devices and have a stock on hand which is available for immediate use and which would do much to speed up the production of cars now.

The most logical course to pursue in the formulation of standards appears, therefore, to be along the lines of standard dimensions and standard strength. By standard dimensions the makers of specialties will be forced to provide equipment interchangeable with that of their competitors and thereby increase the facility with which repairs may be made. By specifying standard strength, a car will be obtained which will meet better the operating conditions throughout the country and as the standards become more generally adopted, will keep many cars off the repair tracks. It will mean the elimination of the poorly designed, cheap car which some roads still persist in building. Such a program of standardization will be welcomed by everyone, both the railroads and public alike.

The Standardization of Locomotives

Reports from Washington indicate that the possibility of the adoption of several types of standard locomotives is receiving considerable attention. The problems of generally adopting standard types of locomotives is one which requires the most careful consideration from many different angles. Under the present conditions the question of paramount importance, however, is—will it materially increase the effectiveness of our prosecution of the war? As a permanent national policy, it may or may not be advisable, but unless it offers the immediate prospect of materially increasing the capacity of our transportation system, beyond what may be done without the introduction of so great an innovation, we are not justified in giving the plan serious consideration at the present time. We now have no permanent national railroad policy. What that policy shall be eventually no one now may definitely predict. The question of the permanent introduction of standard types of locomotives should be left to be carefully weighed as a part of the broader question of our general railroad policy.

At the present time, therefore, we must confine ourselves to the consideration of this matter *purely as an emergency war measure*. There are several apparent advantages, both to the purchaser and the builder which justify careful consideration from this standpoint. If a small number of standard types can be settled upon, there may be an advantage in first cost. The ability to build many locomotives of stock designs gives the builder the advantage in the material market of anticipating the requirements of his customers, without tying up capital in material only suitable for the locomotives of one design and likely to be ordered by one railroad only. Furthermore, it reduces the burden which must be borne by each order of locomotives of a new design incident to the providing of new dies, forms, patterns, templates, etc.

Under present conditions, however, questions of financial economy are of much less importance than increasing transportation capacity. A standard locomotive must of necessity be a compromise designed to meet the average of many varying sets of conditions. Its general use must therefore re-

sult in a loss of transportation efficiency in many cases, due to the necessity for reducing trainloads, and under other conditions where trainloads are determined to some extent by the nature of the traffic and by other facilities, it may even result in a waste of locomotive capacity which cannot fully be utilized. It is therefore evident that the advantages of first cost offered by the plan of standardization must inevitably be obtained at the expense of operating economy and what is of greater importance, transportation capacity.

To the builder the standard locomotive provides the advantages of quantity production and, to a limited extent, continuous operation of his plant at full capacity in anticipation of future orders. It might, therefore, ultimately result in an increased output of locomotives, provided again that the number of standard designs be kept small. A general standardization, however, must provide a multiplicity of designs to meet the requirements for different types and for even a minimum number of sizes of each type. The practical attainment of this apparent advantage is therefore very doubtful and its immediate attainment in time to be a real factor in improving the existing shortage of power is still less probable. The builders' shop programs are practically all laid out for months to come with domestic orders for which material is now on hand or already ordered, and all the preliminary work which is completed for these orders would have to be done before standard locomotives could be built. Equal or better immediate results can be obtained by building duplicate orders of designs already in service.

One of the suggested advantages of the adoption of standard locomotives is the increased facility with which reserve motive power may be mobilized wherever occasion requires. The transfer of standard locomotives, some of which are in service on all railroads, from one railroad to another may be expected to be followed with much less difficulty both in maintenance and operation than a transfer of locomotives standard only on the owning road. To be of greatest advantage in this respect, however, such locomotives must be made quickly available. As the operation of the railroads under government control continues, the general co-ordination of railroad facilities will result in a better control of traffic distribution to prevent local congestions, rather than a shifting of facilities to relieve local congestions. Attention should be directed to building up the power supply where the greatest shortage exists; then keep the power at home. Even the transfer of locomotives from one division to another of the same system, where water and fuel conditions differ, is always attended with many difficulties which take time for straightening out before smooth operation is resumed.

It is, therefore, evident that there are no real advantages of standardization as a war measure. What will it cost in increased operating and maintenance difficulties? Not all of our transportation difficulties have been due to lack of motive power. If the adoption of standard types of locomotives decreases the operating efficiency on some roads by reducing trainloads and hence increasing train movements, the capacity of terminal facilities will still further be overtaxed. Transportation yards are usually rated by their car capacity, but their working capacity is also a function of the number of train movements. The effect of increased train movements upon locomotive terminal facilities already overtaxed, will not result in relieving congestion and delays at this critical point in the transportation machine. Even if train loads are maintained by double-heading the difficulty of keeping up the power and turning it without delay will be increased, and operating costs will go up.

Many roads have been developing their own standards of locomotive construction, in order to secure interchangeability of details. The purpose has been to reduce the amount of stock of renewal parts which must be carried to a minimum and to make possible the making and finishing of these parts on a manufacturing basis. After much effort

in many cases it has been possible to carry out these plans to the point where a large amount of special shop equipment has been provided to make possible the economical manufacture of parts. Patterns for many castings are applicable to several classes of locomotives, special turret lathe equipment has been established for the quantity manufacture of motion work pins, many jigs and templates have been provided for performing standard operations, bolt sizes and tapers have been standardized in order that standard drills and reamers may be supplied to all shops and the repair practices for the system retained under effective control. No doubt the seriously disturbing influence which the imposition of a set of universally standard classes of locomotives would have on the organization and efficiency of operation of shops on such roads could in time be overcome, but the wisdom of throwing the burden of such disorganization upon the maintenance departments in a time of national crisis is very doubtful.

Another matter which should be given careful consideration is the difficulty, generally accompanying the introduction of a new design on any railroad, of effecting the numerous changes in the design necessary before the best service can be obtained from the locomotives. Better results in this respect would be obtained if each railroad were to be permitted to duplicate orders of existing designs which have been thoroughly tried out in service. Following the introduction of standard locomotives it can hardly be expected that any two railroads will find exactly the same changes necessary to best meet their individual requirements. In order to maintain the standards it would therefore be necessary to place rather rigid restrictions on local authorities in the matter of alterations. This would tend to make the locomotives generally unpopular in service and in the shops, and it would be a point of friction which should be avoided at the present time. The fact must not be overlooked that the whole status of our railroad industry was suddenly changed over night and the change is such as to require a complete alteration of the mental attitude of railroad officers and employees generally. Mental habits are strong; they cannot be changed over night and during the period of transition it is highly important to avoid every possible point of friction. Nothing should be done which will tend to discourage men who now are and have been honestly doing their utmost to keep the transportation machine operating smoothly under an exceedingly heavy overload. Nothing is more discouraging than the curtailment of the exercise of local initiative and resource.

If standard locomotives are adopted there is no question but that every railroad man will do his utmost to adapt himself to them. They possess such positive disadvantages, however, that the plan should be dismissed as a war emergency measure.

NEW BOOKS

Shop Expense Analysis and Control, By Nicholas Thiel Ficker, consulting engineer and lecturer on factory engineering and cost production, New York University, 229 pages, 6 in. by 9 in., illustrated, bound in cloth. Published by the Engineering Magazine Company, New York. Price \$3.

This book was published to meet the demand of manufacturers and accountants to have in a concise form material on the subject of shop expense which has previously been published by the author in the *Engineering Magazine*. Eight of the twelve chapters of this book were run as a series of articles in that publication, four chapters having been added to show a more definite application of the subject. The purpose of this book is to provide a means for accurately treating the question of shop expense, subdividing it among the proper items in the cost of manufacture and production of work. While it applies particularly to industrial plants, it has many thoughts which will be of assistance in operation and accounting in railway shops.

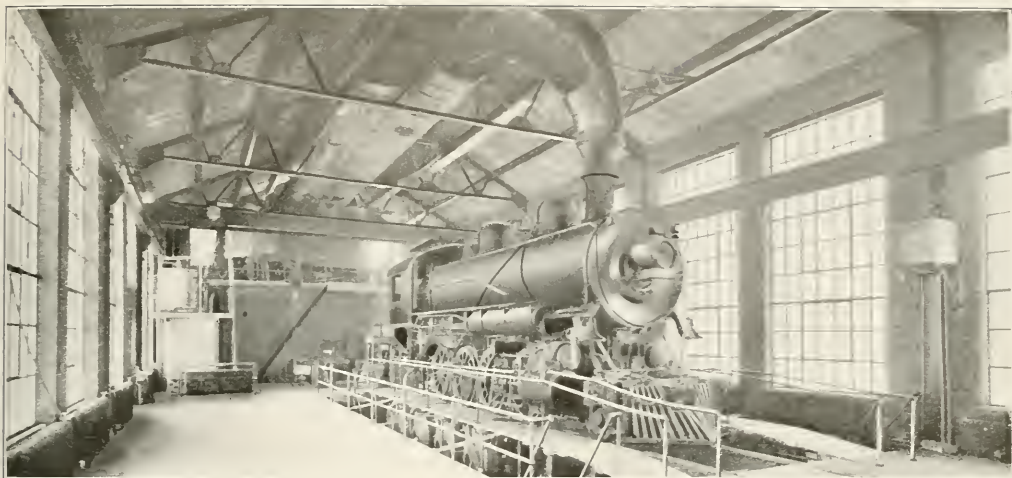

Interior of the University of Illinois Testing Plant.

INTENSIVE LOCOMOTIVE DEVELOPMENT

The Possibilities of Increased Economy of Operation from More Accurate Knowledge of Principles

BY O. S. BEYER, Jr.

PART I

IT is a significant fact that many of the improvements and economies in operation which railways have been able to effect in the last ten years under the stress of adverse conditions have centered very largely around the locomotive. Previous to this, extensive curvature elimination and grade reduction had received chief attention, involving very large expenditures, justified by the financial conditions which then existed. But with the increasing difficulty of securing ample funds attention to opportunities for further economies was forced into directions requiring less initial expenditure. Quite naturally then the steam locomotive was subjected to scrutiny.

Since the most readily appreciated remedy for the evil of increasing operating expenses has always been the reduction of train mileage by increasing the train load, the first step was to enlarge the hauling capacity of the locomotive. But the limits of this process soon began to manifest themselves. The larger locomotive required more coal and coal was becoming more expensive. Its train grew longer, heavier, more difficult to handle and furnished the train crew with arguments for higher wages. Attention, however, was devoted to these problems with the result that the stoker, brick arch, superheater, reverse gear and other fuel and labor-saving devices were perfected and introduced. Details of construction and operation of the machine itself were improved. As far as the general process has gone, it has developed the modern locomotive, which is accomplishing with a pound of coal and no more operators than the first locomotive ever built, almost twice as much work as the standard product of ten years ago.

The successes thus far attained ought surely to give sufficient inspiration and courage to proceed most aggressively with the further improvement of the locomotive. The extreme necessities created by the present economic situation,

aggravated so seriously by the war and bound to continue after the war, make it imperative that the steam locomotive as the principal unit employed in the conduct of the railroad industry be more intensely studied and more thoroughly perfected than has so far been done. Hence it is of interest at this time to present at least some of the most important subjects for investigation vitally concerning the locomotive and to suggest them for immediate consideration and action.

The locomotive problems requiring attention may be classified under the following general heads: (1) Fuel; (2) combustion and steam formation; (3) steam utilization; (4) design and construction, and (5) general performance.

FUEL

Investigations falling under this head are perhaps among the most important of all on account of the great economic importance of fuel in the railway industry. At this critical time particularly, complete or even partial results would be of incalculable benefit. These investigations should primarily contemplate securing data on the relative steaming values of the fuels used in railway service as determined from a complete series of boiler performances, as well as maximum evaporative capacity tests. The data should also include information on the spark and smoke production of the various coals and their clinking and honeycombing qualities, in order, if possible, to tie up practical performances of coals with the characteristics indicated by proximate and ultimate analyses and other laboratory tests of selected samples. The fuels which should thus be investigated are: (a) Typical coals from all the important mining districts; (b) various commercially sized and some specially sized coals; (c) land-stored, water-stored and freshly mined coal; (d) powdered bituminous, anthracite, lignite coals and peat, and combinations thereof; (e) oil, lignite, anthracite and bituminous

coals, coke, peat, briquets and possible mixtures of these fuels.

Complete information as outlined would enable the railroads more clearly to specify desirable and necessary characteristics of fuel and to select fuels with far more intelligence than can now be done. It would enable them to determine with much greater accuracy the actual value of the various fuels available instead of solving this vital question by the unscientific methods now employed of "collective bargaining" between coal salesman and purchasing or fuel agent.

Such information would also make it possible better to judge the desirability of introducing new methods of combustion, with the object of utilizing fuels not ordinarily burned. It would furnish new information and experience for combustion engineers and other students of locomotive design and operation and in consequence better ways of generating steam by new combustion methods would be suggested and developed. It would serve as a foundation for a more intelligent preparation and subdivision of the ordinary mine run coals into the sizes best suited for locomotive use.

The work already done along this line is lamentably inadequate as compared with the extent of the problem. What is actually known today is but hazy in nature and certainly can not be very scientifically applied. Some tests have been made to determine the relative steaming value of and the maximum capacity obtainable of certain typical locomotive coals and a limited number of different sized coals. One railroad which has developed this data for coal used on its lines has effected economies which have been far-reaching.

The importance of these problems to the stationary power plants throughout the country has been better recognized, and the United States Government, through the Bureau of Mines, has for many years been conducting extensive experiments to help solve them. Several large power producers, prominent among them the Commonwealth Edison Company of Chicago, know exactly what they should pay for each ton of fuel from any mine within the limits of the district supplying them.

It is entirely possible, mechanically, to prepare fuel in a highly pulverized form and burn it in the locomotive furnace. The machinery for doing this has been developed and is in successful operation. The next logical step is to determine accurately just what is the complete economic value of the utilization of pulverized fuel. The many general advantages which are bound to follow its use are, of course, recognized. But it is not known how much, for instance, the evaporation per pound of coal is increased at different rates of combustion. The heat balances over the complete range of boiler capacities of a few typical boilers fired with pulverized fuel have yet to be compared with the balances of these same boilers fired with ordinary fuel. And lastly values as exact as possible of the increase in capacity of the pulverized fuel fired boiler should be established. It is not yet possible completely and finally to judge the wisdom of widely introducing this system of combustion.

COMBUSTION AND STEAM GENERATION

The next group of problems presenting itself has to do with the conversion of the energy in the fuel into that of the steam. Here also are many opportunities for scientific research. A few of the important ones will be considered.

The Chemistry of Combustion.—A detailed study should be made of the chemical reactions taking place during the process of combustion under varying conditions in the different parts of the locomotive furnace, principally throughout the fuel bed. The theory of combustion as it exists to-day applied to the burning of locomotive fuel, is incomplete, and fails to explain the occurrence of some very important phenomena, especially with reference to fires of varying thickness, clinkering, coking, the nature of the higher hydrocarbon products of combustion, etc.

The United States Bureau of Mines has done and is still doing some work in this field, using a model furnace. It

might well be extended to a model or actual locomotive furnace, working under locomotive combustion conditions.

Firing Practices.—A far more extensive investigation than thus far attempted should be made of locomotive firing practices, both with and without the assistance of devices for conserving the energy of the fireman, such as automatic fire doors, pneumatic grate shakers and mechanical stokers. The purpose of this should be to determine the most economical combination of practice, devices, and kinds of fuel possible. Maximum boiler capacities resulting from the combinations as well as relative smoke production should be determined.

Heat Absorption.—A detailed experimental as well as mathematical study of the process of heat transfer in the locomotive boiler should be made, especially with reference to the distribution of the heating surfaces between tubes, flues, combustion chamber and firebox. Such a study involves an investigation of gas temperatures throughout the entire boiler from the time the gases leave the fuel bed until they enter the stack. The results would greatly increase the existing knowledge of the proper relation between tube length, diameter, and thickness of wall, particularly as affected by varying initial gas temperatures. A series of tests has been made along this line which indicates that the relation between tube length and diameter for most economical steaming purposes is confined within rather narrow limits. Very much more, however, needs to be done.

Chemical and Physical Nature of Exhaust Gases.—The student of the complicated reactions going on within the locomotive furnace and boiler is immediately confronted by a lack of information needed to assist in explaining some of these reactions. A splendid opportunity exists to investigate the products of combustion as they appear in the locomotive front end, after they have done their work. The results might go a long way toward explaining the mysterious "unaccounted for" losses in the heat balance.

Accurate Smoke Measuring and Indicating Device.—Jointly with the foregoing investigation, attempts should be made to develop accurate locomotive smoke measuring and indicating devices. This can be done in all probability by static-electrical precipitating methods. The ordinary Ringelmann charts frequently used employ arbitrary standards of blackness and are entirely unsatisfactory, as indeed any such method is bound to be when used on a stack where the smoke is quite frequently obscured by the presence of condensing exhaust steam.

The Drafting System.—Tests already made have indicated the great influence of the so-called spark losses on the performance of the locomotive boiler. Some of the factors affecting spark losses are known and others are suspected. Principal among these are draft conditions. An investigation of the entire drafting system of the modern locomotive can not be made too soon. The proportioning of ash pan opening, grate opening, gas areas between the end of the arch and the door sheet, of flues, tubes, the superheater damper, the space under smoke box diaphragm and of the smokestack should all be carefully determined and general values for them expressed in empirical formulae having a wide range of application. This is far from accomplished to-day. Consideration of the relation of these areas is but incidental.

The status of the front end arrangement is in a similar situation. The best that can be said for it as adopted to-day is that a locomotive will steam with it. But that is not sufficient. Aside from the free production of steam, the front end should insure this production with the least waste possible. There are no guarantees that this is actually the case. The front end in the modern locomotive, in the greatest number of cases, is simply a series of adjustments made in a space previously limited, but now further crowded by the introduction of the superheater header. This crowding is only partly relieved by resorting to outside steam pipes. The comprehensive front end tests on the small saturated

steam locomotive conducted jointly by Purdue University and the American Engineer have furnished most of the fundamental data used. However, in view of the vast increase in boiler sizes, accompanied by the further limitation of space in the front end, it is most desirable that these historical tests be repeated on modern power.

The Laws of Resistance to Flow of Gases.—Concurrent with the preceding investigations of the entire drafting system, information should be developed which will establish the laws of resistance to the flow of the gases employed in steam generation through the fire bed, over the brick arch and firebox heating surfaces, through the tubes and over the superheater tubes. Just as careful observations of the flow of air around aerofoils, stream line bodies and other bodies, by means of wind tunnel experiments, have resulted in the important information without which the modern airplane would be an impossibility, so will a similar detailed study of the flow of gases through the locomotive boiler reveal possibilities for reducing their resistance to flow, and perhaps at the same time suggest ways for effecting greater interchange of heat between these gases and the heating surfaces.

Radiation Losses.—Another detail of boiler performance which needs light is that of radiation. Very little is known about this important item, and in consequence losses resulting therefrom are thrown in with those considered as "unaccounted for." It is entirely possible to develop data on this

point, especially with the perfected methods of pyrometry now in existence.

Locomotive Feed Water Heating.—After a long period of development the locomotive feed water heater is at last becoming available. As it stands to-day, it is perhaps one of the finest examples of the results of scientific experimentation applied to the solution of locomotive problems. The good work, however, should not stop. As long as feed water can be heated to still higher temperatures, as long as there are heat units still going up the stack which might be saved, the feed water heater investigation should continue.

Locomotive Boiler Performance.—Lastly the whole general subject of locomotive boiler performance needs more study. But unfortunately the available reliable test data covering a sufficient range of performance is entirely too limited for this purpose. Consequently little opportunity exists for developing an extensive and well founded theory of locomotive boiler design. This manifests itself in the wide variation of boiler proportions chosen by different railway companies. It is entirely reasonable that one combination of the many variables entering into boiler construction as applied to each of the general types of boilers, is bound to be better than the present condition of many different combinations, due allowance being made of course for local conditions.

(To be continued.)

ACTIVITIES OF THE DIRECTOR-GENERAL

New Appointments Announced; Standard Car and Locomotive Committees; Order Governing Labor

DIRECTOR GENERAL of Railroads William G. McAdoo announced the permanent organization of his railroad staff on February 6 as follows:

Assistant to the Director General, Walker D. Hines, chairman of the executive committee and general counsel of the Atchison, Topeka & Santa Fe.

General counsel, John Barton Payne.

Director, division of transportation, Carl R. Gray, president, Western Maryland.

Director, Division of Traffic, Edward Chambers, vice-of the Atchison, Topeka & Santa Fe.

Director, Division of Finance and Purchases, John Skelton Williams.

Director, Division of Labor, W. S. Carter, president, Brotherhood of Locomotive Firemen and Enginemen.

Director, Division of Public Service and Accounting, Charles A. Prouty, director Bureau of Valuation, Interstate Commerce Commission.

Additional divisions will be created from time to time as conditions justify. The Director General has in contemplation a division on capital expenditures and improvements.

Frank McManamy, chief inspector of locomotive boilers of the Interstate Commerce Commission, has been appointed manager of the locomotive section and is attached to the division of transportation.

The manager of the locomotive section will supervise the condition of, and repairs to, locomotives at all railway shops and roundhouses and at outside shops, in addition to his present duties for the Interstate Commerce Commission as its Chief Inspector of Locomotives.

Henry Walters, chairman of the Atlantic Coast Line and of the Louisville & Nashville, a member of Mr. McAdoo's temporary staff, will continue to act in an advisory capacity.

W. T. Tyler, assistant to the vice-president of the Northern Pacific, and H. T. Bentley, superintendent of motive power and machinery of the Chicago North Western, are

acting temporarily as assistants to Mr. Gray in the transportation division. The Commission on Car Service and the Bureau of Car Service of the Interstate Commerce Commission have been merged and are attached to the transportation division.

EQUIPMENT NEEDS

On February 2 the Director General addressed a circular letter calling for complete information as to new equipment, additions, betterments, extensions, etc., already contracted for or which are considered necessary for 1918. The roads are asked to send one copy of the answers with all possible despatch to their respective Regional Directors and the other to the Interstate Commerce Commission.

In determining what additions and betterments, including equipment, and what road extensions should be treated as necessary, and what work already entered upon should be suspended, the roads are asked to be guided by the following general principles:

"From the financial standpoint it is highly important to avoid the necessity for raising any new capital which is not absolutely necessary for the protection and development of the required transportation facilities to meet the present and prospective needs of the country's business under war conditions. From the standpoint of the available supply of labor and material, it is likewise highly important that this supply shall not be absorbed except for the necessary purposes mentioned in the preceding sentence.

"Please also bear in mind that it may frequently happen that projects which might be regarded as highly meritorious and necessary when viewed from the separate standpoint of a particular company, may not be equally meritorious or necessary under existing conditions when the government has possession and control of railroads generally and therefore when facilities heretofore subject to the exclusive control of the separate companies are now available for com-

mon use whenever such common use will promote the movement of traffic.

"While the questions and blanks group together additions and betterments designed to improve capacity, efficiency and economy, this is done because of the difficulty of drawing sharp lines between these objects. It is important to emphasize, however, that under existing conditions the primary thing to accomplish is increased capacity to handle the traffic of the country."

Among the information asked for was the following:

"Submit statement of equipment authorized or contracted for, or the contracting for which during the calendar year 1918 is believed by the management to be necessary for the proper conduct of the business.

"Show the number of units, listing separately locomotives, cars, and other equipment in accordance with the descriptions relating to type and design carried on the blank form; where and by whom constructed; probable time of delivery; estimated probable cost of each unit; and estimated probable cost of aggregate.

"Show in corresponding detail units of equipment which it is anticipated will be retired from service during the calendar year 1918, with the ledger value thereof, and approximately the way in which such ledger value will be disposed of in the accounts."

STANDARDIZATION OF PURCHASES

John Skelton Williams, director of the divisions of finance and of purchases, is to organize a staff of assistants which will be in the nature of a central purchasing board for the railway administration. Samuel Porcher, purchasing agent of the Pennsylvania Railroad, has been temporarily assigned as assistant to Mr. Williams to conduct a general investigation of the general subject of handling railroad purchases with a view to working out a plan, and other railroad officers will be called in to assist from time to time as occasion may require. It is understood that the administration intends to take charge of the purchase of cars, locomotives, rails, oil and other important items of railway supplies which are to be standardized, but it is not the present intention to take over all railway purchases and undoubtedly most kinds of supplies will continue to be purchased by individual railways as at present. The extent to which the administration will take charge of railway purchases will depend largely on the result of the investigation.

STANDARD CARS AND LOCOMOTIVES

Henry Walters, chairman of the Atlantic Coast Line and the Louisville & Nashville, who is acting as special adviser to Director General McAdoo, is in charge of the studies being made for the purpose of establishing standard designs of cars and locomotives to be adopted by the railway administration. Mr. Walters has held numerous conferences with car and locomotive builders on the subject and expects to have several more before anything has been decided.

The committee on cars appointed last summer by the Council of National Defense, at the time when it was proposed to have the government buy freight cars for the railroads, has been delegated to investigate the question of freight car standards. The car committee consists of S. M. Vauclain, vice-president of the Baldwin Locomotive Works; W. H. Woodin, president of the American Car & Foundry Company; J. M. Hansen, president of the Standard Steel Car Company; N. S. Reeder, vice-president of the Pressed Steel Car Company and Clive Runnels, vice-president of the Pullman Company.

The committee on locomotives appointed last summer by the Council of National Defense, of which S. M. Vauclain, vice-president of the Baldwin Locomotive Works, is chairman, has also made a report recommending several standard types of locomotives to Mr. Walters. The recommended standards were then referred to a committee of railroad mo-

tive power officers, consisting of three appointed by each regional director, for their consideration and report. The railroad committee has been holding conferences on the subject since February 22 and will report back to Mr. Walters.

H. T. Bentley, superintendent of motive power and machinery of the Chicago & North Western, now acting as assistant to C. R. Gray, director of the division of transportation in the Railroad Administration, has been appointed chairman of the committee and the other members are as follows: Eastern district, H. Bartlett, chief mechanical engineer, Boston & Maine; William Schlafge, general mechanical superintendent, Erie; and H. L. Ingersoll, assistant to the president, New York Central; Southern district, R. W. Bell, general superintendent of motive power, Illinois Central; W. H. Lewis, superintendent of motive power, Norfolk & Western, and J. Hainen, assistant to vice-president, Southern Railway; Western district, Robert Quayle, superintendent of motive power and car department, Chicago & North Western; W. H. Wilson, assistant to first vice-president, Northern Pacific; and John Purcell, assistant to vice-president, Atchison, Topeka & Santa Fe. J. T. Wallis, general superintendent of motive power, Pennsylvania Railroad has also taken part in the conferences.

The locomotive builders' committee, besides Mr. Vauclain, includes Andrew Fletcher, president of the American Locomotive Company, and H. P. Ayres, vice-president of the H. K. Porter Company.

POLICY AS TO LABOR

In a letter to the Regional Directors on February 4 the Director General outlined the labor policy as follows:

"As to labor, you have been advised of the appointment of the Railroad Wage Commission. The general policy as to all labor is that there shall be no interruption of work because of any controversies between employers and employees. All matters relating to wages and living conditions will have the consideration of the Railroad Wage Commission.

"Pending action by me upon the report of that commission there ought not to be any radical change in existing practices without submitting the matter to me for approval. But it should be understood that the usual methods of settling by agreement ordinary grievances and complaints shall continue as heretofore and that the companies are free to negotiate as heretofore with their employees and are expected to observe faithfully existing agreements with their employees. In cases of doubt about new negotiations with employees, the advice of the Director General should be sought.

"You should bear in mind that labor has the very natural feeling that railroad managers, although now working for the government and on government account, necessarily continue the same conception of and attitude towards labor problems that they had when acting under private management. I am told that labor will have a natural suspicion that any unfavorable action taken by railroad managers indicates a purpose on their part to make governmental control a failure and to use it for promotion or vindication of their own theories. For these reasons, great care should be taken to avoid anything having even the appearance of arbitrary action, and it will be expedient, at least at the outset and until the matter shall take more definite shape, not to dispose, unless by mutual agreement, of any labor claims involving large questions of policy without first submitting the matter to me.

"In the central organization in Washington I propose to have a labor man as a member of my staff who will give his special attention to labor problems, not only to the problems of wages and conditions but also to the problem of aiding the railroads in obtaining sufficient labor and of bringing about a better understanding between officers and em-

ployees. The morale and esprit de corps of officers and men should be brought to the highest standards."

GENERAL ORDER NO. 8, GOVERNING LABOR CONDITIONS

To correct numerous misunderstandings that have arisen as to the relations between railroads and their employees, Director General McAdoo has issued in General Order No. 8 a statement outlining his desires as to labor conditions.

The order directs that:

(1) All acts of Congress to promote the safety of employees and travelers upon the railroads, including acts requiring investigation of accidents on railroads, and orders of the Interstate Commerce Commission made in accordance therewith, must be fully complied with. These acts and orders refer to hours of service, safety appliances and inspection. Now that the railroads are in the possession and control of the government, the statement says, it would be futile to impose fines for violations of said laws and orders upon the government; therefore it will become the duty of the Director General in the enforcement of said laws and orders to impose punishments for wilful and inexcusable violations thereof upon the person or persons responsible therefor, such punishment to be determined by the facts in each case.

(2) When the exigencies of the service require it, or when a sufficient number of employees in any department are not available to render the public prompt transportation service, employees will be required to work a reasonable amount of overtime. So far as efficient and economic operation will permit, excessive hours of employment will not be required of employees.

(3) The broad question of wages and hours will be passed upon and reported to the Director General as promptly as possible by the present Railroad Wage Commission. Pending a disposition of these matters by the Director General, all requests of employees involving revisions of schedules or general changes in conditions affecting wages and hours, will be held in abeyance by both the managers and employees. Wages, when determined upon, will be made retroactive to January 1, 1918, and adjusted accordingly. Matters of controversy arising under interpretations of existing wage agreements and other matters not relating to wages and hours will take their usual course, and in the event of inability to reach a settlement will be referred to the Director General.

(4) In order No. 1, issued December 29, 1917, the following appeared:

"All officers, agents and employees of such transportation system may continue in the performance of their present regular duties, reporting to the same officers as heretofore and on the same terms of employment."

The impression seems to exist on some railroads, the order says, that the said order was intended to prevent any change in the terms of employment during governmental operation. The purpose of the order was to confirm all terms of employment existing upon that date, but subject to subsequent modifications deemed advisable for the requirements of the service. Any contrary impression or construction is erroneous. Officers and employees will be governed by the construction here given.

(5) No discrimination will be made in the employment, retention, or conditions of employment of the employees because of membership or non-membership in labor organizations.

The order concludes with the following:

"The government now being in control of the railroads, the officers and employees of the various companies no longer serve a private interest. All now serve the government and the public interest only. I want the officers and employees to get the spirit of this new era. Supreme devotion to country, an invincible determination to perform the imperative duties of the hour while the life of the nation is im-

perilled by war, must obliterate old enmities and make friends and comrades of us all. There must be co-operation, not antagonism; confidence, not suspicion; mutual helpfulness, not grudging performance; just consideration, not arbitrary disregard of each other's rights and feelings; a fine discipline based on mutual respect and sympathy; and an earnest desire to serve the great public faithfully and efficiently. This is the new spirit and purpose that must pervade every part and branch of the National Railroad Service.

"America's safety, America's ideals, America's rights are at stake. Democracy and liberty throughout the world depend upon America's valor, America's strength, America's fighting power. We can win and save the world from despotism and bondage only if we pull together. We cannot pull apart without ditching the train. Let us go forward with unshakable purpose to do our part superlatively. Then we shall save America, restore peace to a distracted world and gain for ourselves the coveted distinction and just reward of patriotic service nobly done."

RAILWAY SHOP EMPLOYEES

Director General McAdoo also announced that the railroad shop employees, realizing the necessity of assisting the government in the operating of the railroads on a more efficient basis and to meet the present emergency in the repairing of locomotives, acting through A. O. Wharton, president, railway employees' department, American Federation of Labor, and the international officers representing the machinists, boilermakers, blacksmiths, carmen, sheet-metal workers, electrical workers, and apprentices and helpers, have agreed to these changes in working conditions:

(1) The hours of labor in shops and roundhouses to be governed by the necessities as indicated by the general condition of equipment. At shops and roundhouses now working one shift which totals less than 70 hours per week, an increase, preferably on a seven-day basis, may be made. Where desired, working hours may be so arranged that men will be released at 4 p. m. on one day each week. Existing working agreements to govern the rate, subject to the action of the Railroad Wage Commission.

(2) All apprentices who have served three years may be promoted to mechanics and paid the going rate of wages for that position. Such promoted apprentices to be given the right of practical experience on work of their respective trades to which they had not been advanced during the three-year period.

(3) Helpers in their respective trades who have had five or more years' experience may be promoted to classification of mechanics; they to receive mechanics' rate and be given an opportunity to learn all branches of the trade. The duly authorized committeeman of each trade in each shop covered by agreement shall be consulted, and mutual understanding arrived at in promoting helpers; and the ratio of helpers to be promoted, to the number of mechanics, in any one trade in any one shop, shall not exceed 20 per cent. The international officers and general chairmen of each trade on each road covered by agreements shall be furnished a complete record of the men promoted.

(4) Mechanics applying for employment will not be denied such employment for any cause other than inability to perform the work; this preference rule to be in effect as long as three-year apprentices or promoted helpers are employed at mechanics' rates.

(5) Where a reduction is made in the force of mechanics, promoted helpers in accordance with their seniority shall be set back first; then advanced apprentices; no mechanics to be laid off until all such promoted helpers and apprentices have been set back.

(6) The promotions above referred to are to meet an emergency caused by the war, and shall cease at the close of the war.



Consolidation Type Locomotive.

LOCOMOTIVES FOR FRENCH RAILWAYS

Consolidation Type Engines for Freight Service
Built in America from Basic American Designs

TWO orders of consolidated locomotives, aggregating 140 engines, have recently been completed by the American Locomotive Company for France. The Chemins de Fer du Midi received 40 and the French State Railway 100 locomotives, the design being the same in both cases with the exception of the diameter of the driving wheels and some other minor differences.

The engines are of basic American design modified in fittings and fixtures to suit French practice. They were designed by the builder, and each drawing was approved by a representative of the railway. The dimensions are in

sign in general follows American practice, a good grate area being obtained by the use of a short, wide firebox. The firebox is fitted with a brick arch and the boiler includes a 26-element superheater. Handholes are used instead of washout plugs to give greater accessibility for washing out. A dump grate in the front of firebox is operated from the cab by a screw, and the outside end of the blowoff cock has a special thread for connection to the fire hydrants of the city of Paris. In order to quickly free the stack of smoke, the blower is fitted with a quick-opening valve operated from either side of the cab. Lagging on the boiler is omitted; the

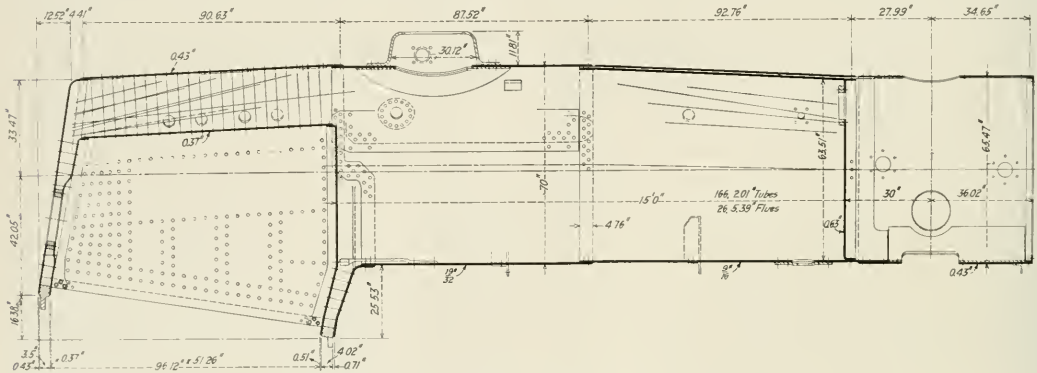

Longitudinal Section of the Boiler for the French Locomotives

the metric system, the International system of screw threads, and the French-Westinghouse system of pipe threads.

The locomotives all have cylinders 23 in. by 26 in., and carry 170.6 lb. boiler pressure. Owing to the slight difference in the diameter of the drivers there is a difference of 1,000 lb. in the tractive effort of the two orders, the locomotives for the French State Railway developing a tractive effort of 35,200 lb., while those for the Midi develop 36,200 lb. While the boiler capacity is low in relation to the cylinder capacity, it compares very favorably with recently built locomotives of the same type for use on American railroads.

The dimensions of both boilers are identical. The de-

jacket is supported on a crinoline frame leaving an air space which acts as a non-conductor.

The firebox is fitted with an inside opening firedoor to meet the requirements of a French law. The door is hinged at the top and is opened by means of a lever extending upward at one side of the door frame. This lever is fitted with a latch, which operates in a quadrant provided with notches permitting the door to be fastened in wide open, partially open and closed positions. The door opens inward and upward, and when closed hangs at an angle of about 25 deg. from the vertical.

Among the points of general interest in the design, it will be noted that the locomotives for both railroads are

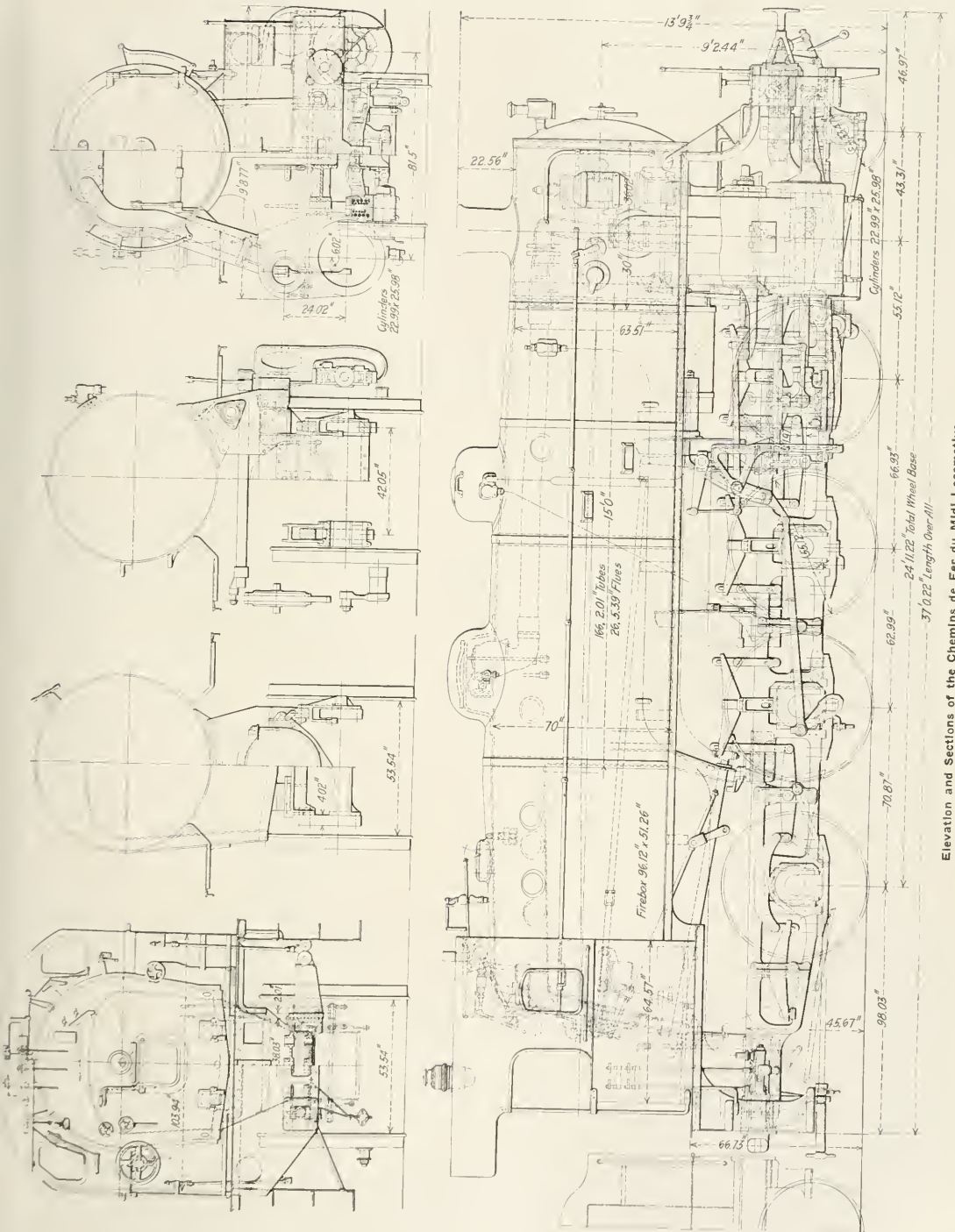

Elevation and Sections of the Chemins de Fer du Midi Locomotive

controlled from the left side, contrary to American practice. The steam is distributed by 10¼-in. piston valves, which are controlled by the Walschaert valve gear. The cylinders are fitted with by-pass valves operated by air cylinders, and with muffled cylinder cocks.

All the engines have a variable exhaust operated from the cab by a screw which passes through one of the hand-rails, and the front ends are fitted with spark arresters.

While the running gear in general is designed along the lines commonly followed in this country, the cross-balancing of the driving wheels is contrary to American practice for two-cylinder locomotives. The effect of this practice on the angularity of the counterbalances is clearly indicated in the illustration of the French State Railway locomotive.

A pneumatic sander is combined with a screw conveyor which extends through the sandbox and is operated from the cab.

Roy buffers are applied between the engine and tender

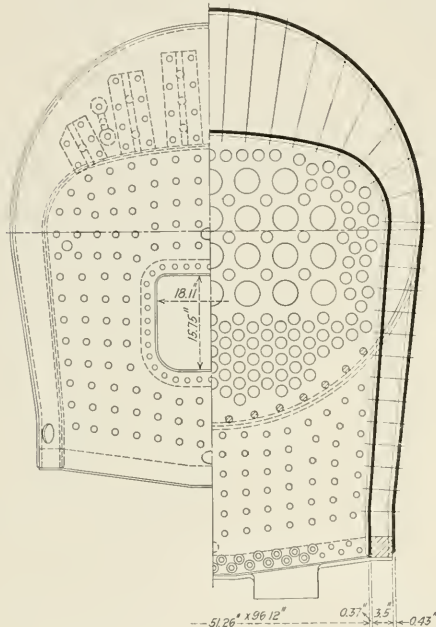

Back Head and Section Through the Firebox

on both orders. The general arrangement of these buffers, together with other details of the engine and tender connections, is shown on one of the drawings. Instead of using one buffer directly over the center line of the drawbar, two buffers are placed one on either side of the center of the locomotive, the angle of the bearing surfaces in each case being arranged so that angular movement between the locomotive and tender causes a sliding movement of the buffers. The center lines of the engine buffers intersect the center line of the locomotive at the center of the drawbar pin hole. The engine and tender drawbar is of the same type that is generally used between cars in Europe. The ends containing the holes for the drawbar pins are threaded to take a right and left hand screw, by means of which the slack between the engine and tender may be taken up.

Other special types of equipment include French Westinghouse air brakes, French standard buffers and couplers and a water brake.

The general dimensions and data for the two locomotives are given in the table:

General Data		French State	Midi
Gage	4 ft. 8½ in.	
Service	Freight	
Fuel	Bit. coal	

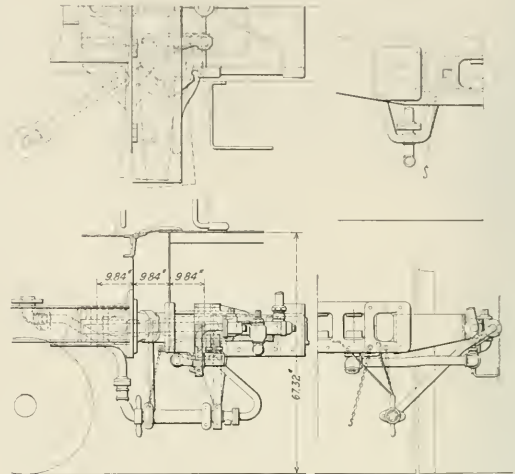

Details of the Engine and Tender Connection.

Tractive effort	35,200 lb.	36,200 lb.
Weight in working order	160,000 lb.	159,500 lb.
Weight on drivers	139,000 lb.	138,500 lb.
Weight on leading truck	21,000 lb.	
Weight of engine and tender in working order	266,400 lb.	264,500 lb.

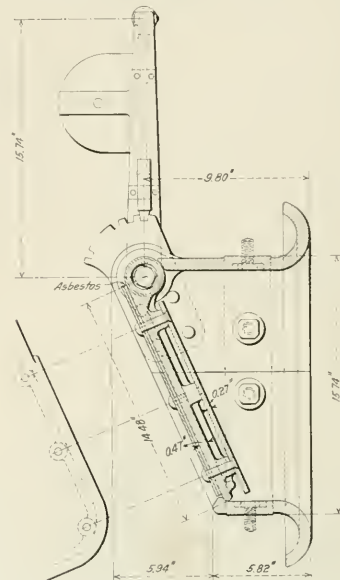

Inside—Opening Fire Door for the French Locomotives.

Wheel base, driving	16 ft. 9 in.	
Wheel base, total	24 ft. 11¼ in.	
Wheel base, engine and tender	53 ft. ¾ in.	

Ratios			
Weight on drivers ÷ tractive effort	4.0	3.9
Total weight ÷ tractive effort	4.6	4.4

Tractive effort × diam. drivers ÷ equivalent heating surface*	748.6	748.5		
Equivalent heating surface* ÷ grate area		76.2		
Firebox heating surface ÷ equivalent heating surface, per cent.		5.3		
Weight on drivers ÷ equivalent heating surface*	52.1		52.0	
Total weight ÷ equivalent heating surface*	60.0		59.8	
Volume both cylinders, cu. ft.		12.5	cu. ft.	
Equivalent heating surface* ÷ vol. cylinders		213.2		
Grate area ÷ vol. cylinders		2.7		
<i>Cylinders</i>				
Kind		Simple		
Diameter and stroke		23 in. by 26 in.		
<i>Valves</i>				
Kind		Piston		
Diameter		10½ in.		
Greatest travel		6 in.		
Outside lap		1 in.		
Inside clearance		Line and line		
Lead in full gear		¼ in.		
<i>Wheels</i>				
Driving, diameter over tires	56¾ in.		55½ in.	
Driving, thickness of tires		2¾ in.		
Driving journals, main, diameter and length		9 in. by 10 in.		
Driving journals, others, diameters and length		8 in. by 10 in.		
Engine truck wheels, diameter		33¾ in.		
Engine truck, journals		5½ in. by 10 in.		
<i>Boiler</i>				
Style		E. W. T.		
Working pressure		170.6 lb. per sq. in.		
Outside diameter of first ring		64½ in.		
Firebox, length and width		96¼ in. by 51¼ in.		
Firebox plates, thickness		Crown, sides and back, ¾ in.; tube, ½ in.		
Firebox, water space		Sides and back, 3½ in.; front, 4 in.		
Tubes, number and outside diameter		166—2 in.		
Flues, number and outside diameter		26—5¾ in.		
Tubes and flues, length		15 ft.		
Heating surface, tubes and flues		1,840 sq. ft.		
Heating surface, firebox		142 sq. ft.		
Heating surface, total		1,982 sq. ft.		
Superheater heating surface		436 sq. ft.		
Equivalent heating surface*		2,666 sq. ft.		
Grate area		34.2 sq. ft.		
<i>Tender</i>				
Tank		Water bottom		
Frame		Channel		
Weight		106,400 lb.		105,000 lb.
Wheels, diameter		37¾ in.		
Journals, diameter and length		5 in. by 9½ in.		
Water capacity		4,756 gal.		
Coal capacity		5 metric tons		

*Equivalent heating surface = total evaporative heating surface ÷ 1.5 times the superheating surface.

CALCULATION OF BOILER STRESSES

A Series of Diagrams Which Will Save Time and Labor in Figuring Strength and Efficiency of Seams

BY G. E. PARKS

Mechanical Engineer, Michigan Central

IN boiler design and the calculation of boiler stresses, systems of curves like those illustrated below have proved of material value in Michigan Central practice. They are not only a great labor saver and aid in checking boiler specification cards, but they will often show at a glance the best possible arrangement of detail or size of part. Their accuracy will depend upon the scale employed.

Fig. 1 shows the relation between the efficiency of the boiler seam and the tensile strength of the plate for various thicknesses of plate and as two systems of curves are represented on a single co-ordinate field, care should be exercised in using the respective scales. The curved lines on the co-ordinate field represent the efficiency of the American Locomotive Company's seam, drawings 142-S-30,080-81-90 (known as seam No. 1), for different tensile strengths of plates. The dimensions of this seam are given in Fig. 2 and the curves are plotted from the equation

$$T = \frac{SA}{E \left(\frac{p}{100} - c \right)}$$

where:

- T = Tensile strength of plate in pounds per square inch.
- S = Shearing strength of rivets in pounds per square inch, taken as 44,000 lb.
- A = Area of rivet hole in square inches.
- t = Thickness of sheet in inches.
- p = Pitch of outside row of rivets in inches.
- E = Efficiency of seam in per cent.
- C = The pitch, minus twice the diameter of rivet hole (p-2d), or the length of metal between alternate rivets in the second row.

The straight lines on the co-ordinate field represent the relation between the efficiency of seam No. 1 and the efficiency of the various other seams as plotted. If we assume that the tensile strengths and thickness of plate is the same in each case, the equation for the straight lines becomes

$$E_2 = 100 \left\{ \frac{A_2 p_1}{A_1 p_2} E_1 + \frac{A_1 C_2 - A_2 C_1}{A p_2} \right\}$$

In this equation the letters represent the values as given above, the subscript figure "1" representing values in seam No. 1 and the subscript figure "2" representing values in the seam under investigation.

The points marked "X" at the lower end of the straight lines representing seams 15 and 57, also seam 64, indicate the position of the curve at which the efficiency of the seam for shearing all of the rivets and the efficiency of the seam when tearing through the second row of rivets and shearing the rivets in the outside row are equal. Therefore, if the thickness and tensile strength of plate in seams 15, 57 and 64 are such that the point of intersection between the curved line representing the thickness of plate, and the horizontal line representing the tensile strength of plate falls at the left of the point "X," the seam will fail by the shearing of all of the rivets. The efficiency is determined as follows:

From the point of intersection between the curved line representing the thickness of the sheet and the horizontal line representing the tensile strength of the sheet, project a line in a vertical direction until it comes in contact with the straight line, marked "Actual Shearing Efficiency." Opposite this point of intersection, read on the vertical scale the shearing efficiency of the seam. The co-ordinate field as plotted does not show the points where the shear of all of the rivets is equal to the efficiency of seam through the second row of rivets, for seams Nos. 2, 3, 14 and 55, therefore, these seams would not fail due to shear of all of the rivets for any thickness of plate or tensile strength of plate, which is given on the drawing.

The equation of the straight line marked "Actual Shearing Efficiency" is:

$$E_{s_2} = \frac{A_2 N_2}{A_1 P_2} (P_1 E_1 - C_1)$$

where:

- E_{s2} = Efficiency due to shear of all of the rivets in seam under investigation represented by the straight line.
- A₂ = Area of rivet hole in seam under investigation.
- A₁ = Area of rivet hole in seam No. 1, represented by the curved lines.
- N₂ = Number of rivet shearing planes of seam under investigation. In all seams plotted on this sheet, N₂ equals 9.
- P₂ = Pitch of rivets in outside row of seam under investigation.
- P₁ = Pitch of rivets in outside row of seam, No. 1.
- E₁ = Efficiency of seam, No. 1.
- C₁ = Pitch minus twice diameter of rivet hole in the seam, No. 1.

At a point representing 85.52 per cent efficiency for seam No. 1 is a vertical dotted line which is the efficiency of the

seam through the first row of rivets. If the thickness and tensile strength of plate are such that the efficiency for seam

No. 1 is higher than 85.52 per cent and is shown on the right of the dotted line, the higher efficiency should not be considered as the seam would fail through the first row of rivets which has an efficiency of 85.52 per cent. At the right end of the straight lines representing seams No. 2, 3 and 14 are the points where failure will occur in the first row of rivets and these points represent the maximum efficiency of the seams. The co-ordinate field is not large enough to show similar points for seams No. 15, 57 and 64.

Problem 1.—To find the efficiency of boiler seam No. 1 having 1½-in. plate, the tensile strength of which is 58,000 lb.

From the point of intersection of the 58,000 lb. line on the horizontal scale and the curve representing a 1½-in. plate, project a line vertically either to the top or bottom axis and read off the efficiency, which is 81.6 per cent.

Problem 2.—To find the efficiency of boiler seam No. 2 having 1½-in. plate, the tensile strength of which is 58,000 lb.

First find the efficiency that seam No. 1 would have under the same conditions, which is 81.6 per cent. Then from the point where the vertical line representing 81.6 per cent intersects the straight line representing seam No. 2 find the efficiency corresponding to this point on the vertical scale, which is 81 per cent.

This system of curves may be used to determine the value of any of the factors in the general equation when the other factors are known.

Problem 3.—To find the tensile strength required for:

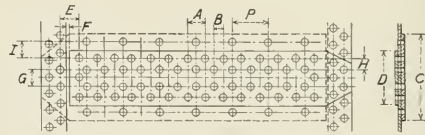

Longitudinal Seam

Seam	Dimensions of Seams											
	Diarm. Rivet	P	A	B	C	D	E	F	G	H	I	
1425300020190 Seam No. 1	1 1/8"	1 3/8"	9 1/2"	4 3/8"	2 3/8"	19 3/8"	12 3/8"	4 3/8"	3 3/8"	3 3/8"	2 3/8"	3 3/8"
143A 3004 Seam No. 2	1 1/4"	1 5/8"	9	4 1/2"	2 1/2"	18 1/2"	11 1/2"	4 1/2"	3 3/8"	3 1/2"	2 1/2"	3 1/2"
1435 3943 Seam No. 3	1 1/8"	1 3/8"	8	4	2	17	10 1/2"	4	3 1/2"	3 1/2"	2	3 1/2"
14	1 1/8"	1 1/8"	7 1/2"	3 3/8"	2 3/8"	16 1/4"	10	3 3/8"	3 3/8"	2 3/8"	2	3 1/2"
15 8.57	1 5/16"	1	7	3 1/2"	2 1/2"	14 1/4"	8 3/8"	3 1/2"	3 3/8"	2 1/2"	1 3/4"	2 3/8"
55	1 5/16"	1	6 1/2"	3 1/2"	2 1/2"	14 1/4"	8 3/8"	3 1/2"	3 3/8"	2 1/2"	1 3/4"	2 3/8"
64	1	1 1/8"	7 3/4"	3 3/8"	2 3/8"	16 3/8"	10 1/8"	3 3/8"	3 3/8"	3 1/2"	2 1/2"	3 1/2"

Fig. 2—Dimensions of Standard Boiler Seams

15/16-in. plate to give an efficiency of 80.5 per cent, using seam No. 14 as an example.

On the vertical scale of efficiency find 80.5 per cent, and project a line in a horizontal direction until it intersects the line representing seam 14. From this point project vertically to the 15/16-in. line, and this intersection projected to the vertical axis gives a tensile strength of 57,000 lb. per sq. in.

Problem 4.—If seam No. 14 has an efficiency of 80.0 per cent what will be the efficiency of seam No. 2, providing that the thickness of plate, tensile strength of plate and shearing stress of rivets are alike for both seams?

From the point where the 80.0 per cent line from the vertical scale intersects the line of seam No. 14, project a line vertically to the line of seam No. 2 and from this point project a line horizontally and find the efficiency, which is 82.7 per cent.

Fig. 3 shows the stress on several sizes of stay bolts, under conditions varying from supporting 13 sq. in. to 22 sq. in.

Fig. 1—Seam Efficiency for Varying Tensile Strength and Thickness of Plate

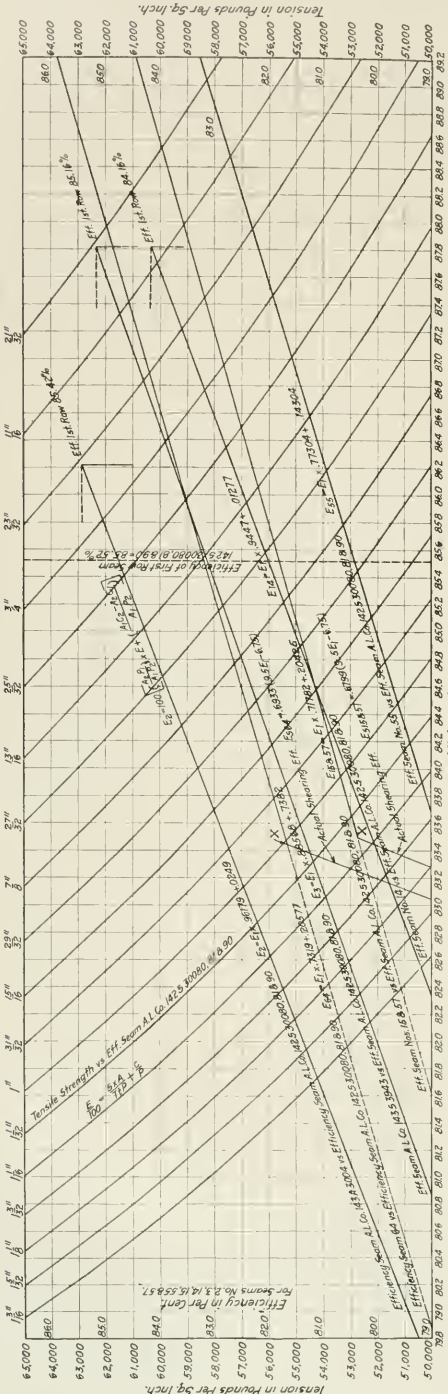

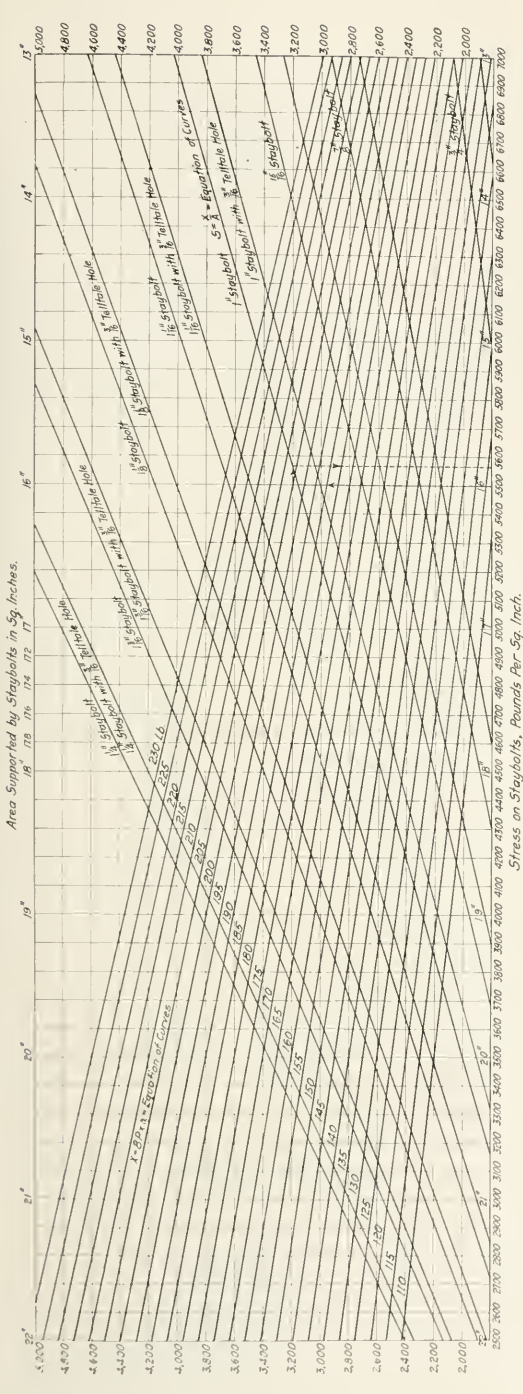

Fig. 3—Staybolt Stress for Varying Boiler Pressure and Supported Area

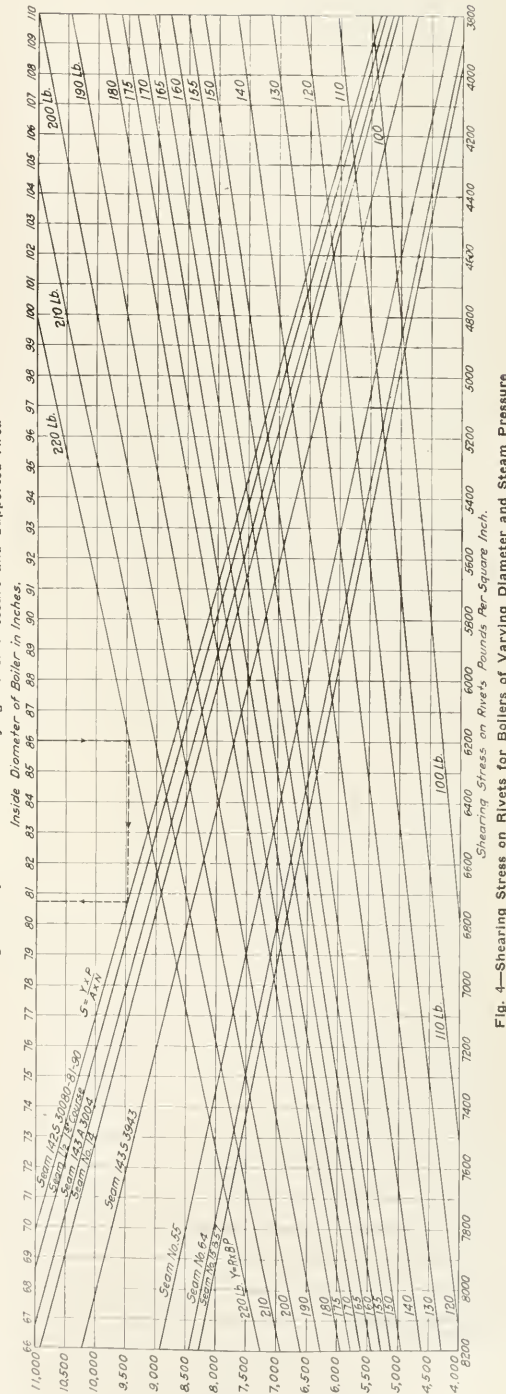

Fig. 4—Shearing Stress on Rivets for Boilers of Varying Diameter and Steam Pressure

of area with boiler pressures varying from 110 lb. to 230 lb. gage, advancing by five pounds each.

The general equation is

$$S = \frac{BP \times a}{A}$$

where:

- S = Stress on stay bolt in pounds per square inch.
- BP = Boiler pressure in pounds per square inch as shown by gage.
- a = Area in square inches supported by stay bolt.
- A = Area of stay bolt in square inches.

There are two systems of curves on the co-ordinate field, and care should be exercised in using the respective scales. The lines marked with the boiler pressure show the relation between the boiler pressure and the area supported by the stay bolts and the lines marked with the various sizes of stay bolts show the relation between the product of boiler pressure times area supported and the stress on stay bolts as illustrated. The area for the stay bolts is taken at the root of the thread, for a 1" thread, 12 threads per in., and there are also lines for stay-bolts which have 3/16-in. telltale holes.

To use the curve it is first necessary to determine the number of square inches of flat surface that is to be supported.

Problem 5.—What is the stress on a 1-in. solid stay bolt with 1" thread, 12 threads per inch when supporting 16 sq. in. at 200 lb. pressure?

On the horizontal axis, either at the top or bottom, find the area supported, in this case 16 sq. in., and project a line vertically until it intersects the 200 lb. line. From this point project a line horizontally to the right until it intersects the 1-in. stay bolt line. This intersection projected vertically either to the top or bottom axis gives the stress on the stay bolt, which in this case is 5,560 lb. per sq. in.

Fig. 4. Shows the shearing stress on rivets for such seams as outlined for boilers varying from 66 in. to 110 in. in diameter, and for steam pressures between the limits of 100 lb. and 220 lb. gage pressure.

The general equation for shearing stress on rivets is

$$S = \frac{R \times P \times BP}{A \times N}$$

where:

- S = Shearing stress on rivets in pounds per square inch.
- R = Radius in inches of inside of boiler shell.
- P = Pitch in inches of rivets in the outside row of seam.
- BP = Boiler pressure in pounds per square inch as shown by gage.
- A = Area in square inches of rivet hole.
- N = Number of rivet shearing planes in pitch length taken.

The system of straight lines marked with the boiler pressure, represent the relation between the radius of the boiler and the boiler pressure. These lines are expressed by the equation $R \times BP = Y$, Y representing the figures given on the Y-axis. The second system of straight lines represents the relation of the characteristics of each individual seam, so far as shearing stress on the rivets is concerned, to the radius of inside of boiler and boiler pressure.

Problem 6.—What is the shearing stress on the rivets of seam No. 1 when used on a boiler 86-in. inside diameter and carrying 220 lb. pressure?

On the top horizontal axis find the diameter of the inside of the boiler, in this case 86 in., and project a line vertically until it intersects the line marked 220 lb. From this point project a line in a horizontal direction until it intersects the line marked with the seam number, in this case seam 142-S-30,080. This intersection projected vertically to the bottom horizontal axis gives the shearing stress on rivets which is 6,730 lb. per sq. in.

Fig. 5 shows the tension on net section for various thicknesses of plate, boiler pressures, efficiency of seams and diameters of boilers.

The general equation is

$$T = \frac{D}{t \times E} \times BP$$

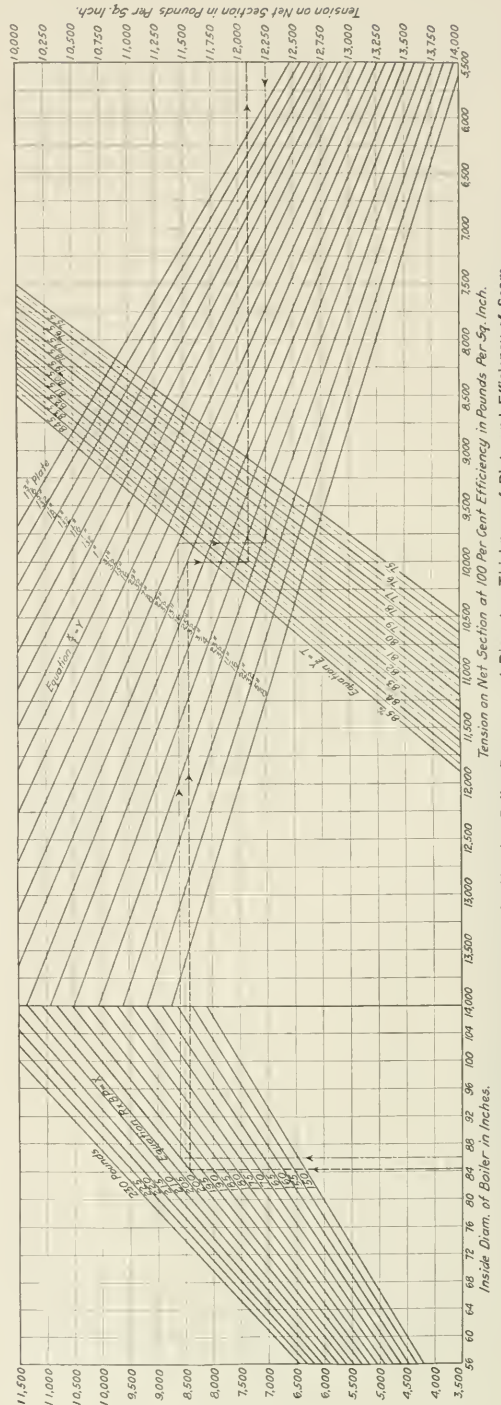

Fig. 5—Tension on Net Section for Varying Boiler Pressure and Diameter, Thickness of Plate and Efficiency of Seam

where:

T = Tension on net section in pounds per square inch.
 $\frac{D}{2}$ = Radius in inches of inside of boiler.

BP = Boiler pressure in pounds per square inch as shown on the gage.
 t = Thickness of plate in inches.
 E = Efficiency of the boiler seam in per cent.

There are two co-ordinate fields shown on the sheet, both of which are used in determining the tension on a net section. One field consists of a series of straight lines showing the relation between boiler pressure and the inside diameter of the boiler. The equation for these lines is

$$X = \frac{D}{2} \times BP$$

where X is equal to the product of boiler pressure and the radius of the inside of the boiler. This is transferred to the second field in obtaining the tension on a net section.

The second field consists of two series of straight lines crossing each other. The series of lines upon which are marked the thicknesses of plate are plotted from the equation

$$Y = \frac{X}{t}$$

where:

Y = Tension on net section at 100 per cent efficiency
 t = Thickness of plate in inches.

X = Value of $\frac{D}{2} \times BP$ as explained above.

The other series of straight lines upon which are marked the different efficiencies, show the relation between the tension on a net section at 100 per cent efficiency and on a net section for the various other efficiencies of seams as noted.

These lines have been plotted from the following equation:

$$T = \frac{Y}{E}$$

where:

T = Tension on net section at the desired efficiency.
 E = Efficiency in per cent.

Y = Value of $\frac{X}{t}$ as explained above.

Problem 7.—To find the tension on a net section of a boiler of 84 5/16-in. diameter, 27/32-in. thickness of plate, 200 lb. boiler pressure and 82.75 per cent efficiency of seam.

From the point representing 84 5/16-in. diameter on the horizontal axis of field No. 1, project a line vertically until it intersects the 200 lb. line and from this point project a line horizontally into field No. 2 until it intersects the 27/32-in. line. Project this point vertically until it intersects the line representing 82.5 per cent, where it will be necessary to interpolate to reach an imaginary line representing 82.75 per cent. This point projected horizontally to the vertical axis gives the desired tension on net section as 12,100 lb. per sq. in.

Problem 8.—What efficiency must a boiler seam have when the tension on a net section is 12,250 lb. per sq. in. with inside diameter of the boiler 86 in., boiler pressure 200 lb. and thickness of plate 7/8 in.

From the point representing 86 in. on the horizontal axis of field No. 1, project a line vertically until it intersects the 200 lb. line, and from this point project a line horizontally into field No. 2, until it intersects the 7/8 -in. line. The projection of this point on the horizontal line showing 12,250 lb. tension on a net section gives the required efficiency which is by interpolation 80.2 per cent.

SNOW AND ICE ON THE PENNSYLVANIA

A Story of a Seven Weeks' Struggle During the Worst Winter the Eastern Railroads Ever Experienced

THE months of December, January and February have been truly characterized as the "worst winter" in the history of railroading in the Eastern United States. Seven weeks of arctic weather with fifteen-foot drifts on tracks, below-zero temperatures, and blinding gales that made regular running of trains impossible and at times stopped movement altogether. The experiences of the Pennsylvania Railroad in this seven weeks' struggle with the forces of nature have been brought together in a report by Elisha Lee, acting vice-president in charge of operation, an abstract of which is presented herewith.

Surveying all divisions of the lines east of Pittsburgh the features of the weather during the period covered by the report, were not only the record-breaking cold, the heavy snowfalls and high winds, but the unprecedented length of the frigid spells, which gave no breathing time to recover and prepare for the next emergency. In the mountain regions traversed by the Pennsylvania these conditions were practically unbroken throughout the entire time from mid-December until the beginning of February.

The shompen stood the acid test of fidelity by shoveling snow, breaking ice and clearing switches, often under weather conditions involving severe hardship. The withdrawal of these men from the shops had a serious effect on repairs and construction, but there was no alternative, as without their aid it would have been impossible to open the lines and restore traffic.

The Altoona shops reported that between December 20 and January 21, their men spent 9,225 ten-hour days in

snow-shoveling and switch-clearing. This resulted in the loss to the shops of class repairs to 19 engines, the building of 39 steel freight cars, the strengthening of 33 cars, heavy repairs to 25 others, light repairs to 45 passenger cars and the manufacture of 350 car wheels. In addition, the operation of the shops in general was unavoidably slowed up by the temporary disruption of the forces.

On the Bellwood division, with a shop force of only 259 men, the shompen spent 11,000 hours in shoveling snow during the same period. This is given in the report as the principal reason for an accumulation of 540 cars awaiting repairs on January 30, the normal capacity of the Bellwood division shops being 150 cars. The Pittsburgh division, for the same reason, reported an accumulation of 2,357 cars awaiting repairs, or 100 per cent above normal.

Showing the disastrous results of a minor accident during severe weather, the Sunbury division reported that during zero weather a truck broke on a freight car east of Boyd, Pa., on the single-track portion of the division. By the time this wreck was cleared, seven following freight trains had frozen up, the crews had to be relieved for rest under the sixteen-hour law, and the cars were stored and the engines towed to the terminal.

Among miscellaneous results reported from the severe cold on all divisions, were air-hose freezing, trains stalling, trains parting due to broken couplings, hot boxes dues to journal boxes being stripped off by snow and ice, broken rails, frozen signals and signal wires, and failure of interlocking plants. Much trouble was experienced with water-

scoops on engines freezing up so that they could not be used. It was frequently necessary to maintain large forces of men at each track tank to remove the accumulation of ice caused by the flying water freezing on the rails and roadway.

The report deals in detail with the effect of extreme cold in lowering the efficiency of unskilled and semi-skilled labor, and in making it impossible in many cases to hold men in the service. On the Cresson division, where conditions were unusually severe, in order to maintain an engine-house force of 149 men, it was necessary to hire 171 new men in four months, making a turnover for that period of nearly

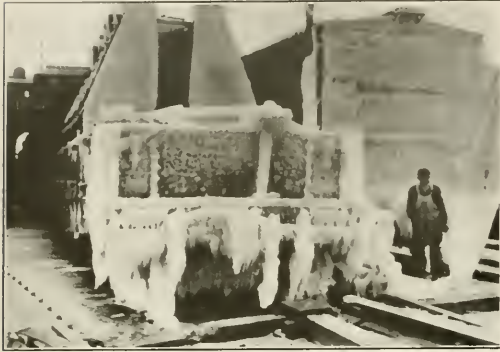

On a Car-float—After a Trip from Norfolk to Cape Charles

115 per cent or at the rate of 344 per cent for the year. The turnover for the entire force of 495 men directly connected with train operations was at the rate of 218 per cent per year.

In the Pittsburgh district the turnover of engine-house

the Pittsburgh division have been in the service less than six months.

The effect of the weather in reducing the average tonnage carried per freight train was, on the Maryland division, 36 per cent; Philadelphia division, 25 per cent; Middle division, 17 per cent; Pittsburgh division, 38 per cent.

Frozen ash-pans in engines caused thousands of delays

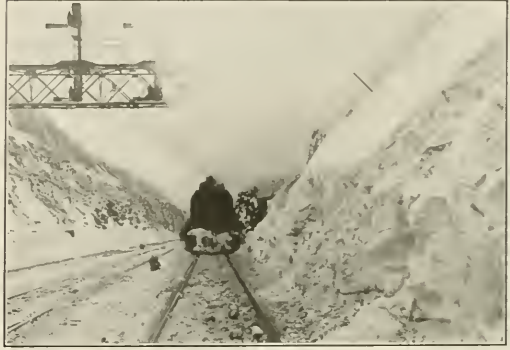

Cut Approaching the Westbound Tunnel near Gallitzin—Drifts 15 ft. Deep

over all portions of the system. Reports on the Cresson and Williamsport divisions show that during zero weather from three to four hours were required to clean one ash-pan, which normally would take from 25 to 40 minutes. The Conemaugh division reported delays due to frozen ash-pans totalling 8,392 hours, which was equivalent to the loss of the services of 35 engines for a month of 30 eight-hour days.

Frozen ash-pans are caused by flying snow, and water

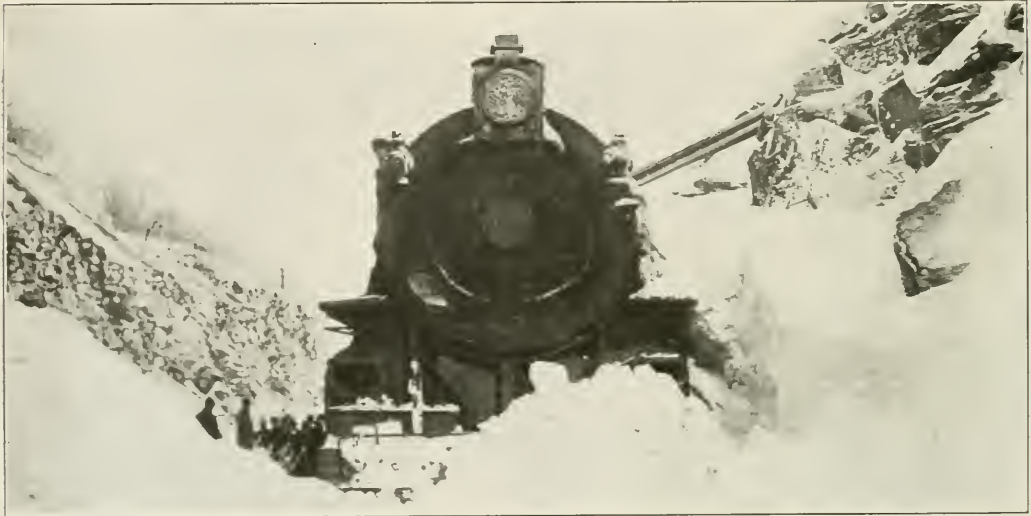

Shop Men Digging Out a Train Stalled on a Branch Line Near Altoona, Pa.

forces was at the rate of 192 per cent per year; for firemen and trainmen 120 per cent and for track forces 351 per cent. Furthermore, 55 per cent of the entire force of freight brakemen and 44 per cent of the entire force of firemen on

dripping from boiler appliances, forming a solid frozen mass with the ashes. Condensed moisture and steam coats the mechanism of the ash-pan so that much time is lost in clearing the working parts, while it is necessary to break

up the solid frozen masses with steam jets and iron bars. Thousands of delays in the very cold weather were due to the lubrication in the journal boxes of cars freezing, especially where the cars were standing in classification yards. In such cases hot oil had to be used before it was possible to move the cars over the hump. It was often found necessary to push cars down the hump grades because the oil in the axle boxes was so stiffened that they would not run by gravity.

The solidly frozen roadbed, which for weeks at a time was as hard and unyielding as a cement pavement, greatly increased the wear and tear on engines and the amount of repairs required. At the Meadows shop, near Jersey City, from December 30 to January 31, 20 engines arrived at the enginehouse with broken frames, which is a greater number of this class of failures than ordinarily occur in a whole year. Many main and side rods of engines were also broken in the efforts to move cars which had frozen to the rails. The Pittsburgh division reported 576 engine failures in January, 1918, as compared with 398 in January of last year, an increase of 45 per cent. The Conemaugh division reported engines out of service for a total of 4,400 hours in making running repairs, which is equivalent to a loss of 18 engines for a month of 30 eight-hour days.

Much trouble with boilers, especially of engines running in the mountain divisions, was reported from the unavoidable use of water of poor quality, due to the low supply streams, some of which were frozen almost solidly for weeks.

This resulted in the failure of thousands of flues and many leaky boilers.

On the night of January 27, when a half dozen through express trains were stalled on the top of the Allegheny mountains near Gallitzin, with the temperature at zero, the wind blowing a gale and the snow drifts in the cuts 12 to 15 feet deep. Train No. 9, the Western Express, with three engines, reached a point half a mile west of Gallitzin, when it was stopped by the snow. The seven rear cars were uncoupled and another engine sent to pull them back, but by the time the tunnel was reached the west portal had drifted shut and it was impossible to go any further. The passengers were taken out of the train and sent to a hotel. It was impossible to move these cars until five o'clock the next afternoon, and then five heavy freight engines were required to pull the seven empty coaches.

Meanwhile the other three cars, together with the three engines which were pulling the train when it stalled, remained a mile and a quarter further on in the drift. Five hundred men worked all the night of January 27 and until the next afternoon, before these three cars and engines were dug out and the track cleared for them to move.

These results, in the face of unprecedented difficulties, were only accomplished by the self-sacrifice, loyalty and devotion to duty of many thousands of officers and employees who cheerfully performed unaccustomed and arduous work and repeatedly faced hardship, danger and real suffering, in the struggle to keep the lines open so that the public and the government might be served.

SUPPLY INTERESTS WRITE MR. MCADOO

An Open Letter to the Director General from the Railway Business Association on Standardization

GEORGE A. POST, president of the Railway Business Association, under date of February 25, sent the following communication to Director General of Railroads McAdoo:

Manufacturers of railway necessities respectfully invite you to study certain considerations bearing upon mechanical design and practice in the field of rolling stock construction, purchase and maintenance.

The Railway Business Association, of which I have the honor to be president, is a national organization of manufacturers, merchants and engineers dealing with steam railroads. What we have to say from our own experience accurately portrays the problems of the whole railway appliance industry.

It appears from your official announcement that you have delegated to technical committees the work of recommending to you a detailed plan of procedure for the acquirement of new rolling stock by the railroad systems. The phases upon which we desire to address you are those which involve the peculiar interest of makers of appliances or parts as distinguished from assemblers of locomotives and cars.

In the field of transportation inventors and developers of special appliances embody the spirit and function of progress. Our interest and the national interest in this respect are identical. What the manufacturers of railway appliances cherish and what the public as a whole is interested in preserving is that flexibility which leaves the way open to mechanical advance. Always we have before us two antagonistic requirements which must be compromised—improvement through change and stability through standardization.

To a certain extent standardization is essential. As transportation became national and interchange of cars among the

several roads became common, convenience and economy in repairs required a tendency toward interchangeability of parts. With the organization of the Railroads' War Board last April came for the first time to any extent use of engines on the rails of roads other than the owner. What has long applied to cars affecting repairs now applies in some degree to engines. The drift, as with cars, is toward interchangeability of parts. The method by which inter-line use of cars was made possible was, to be sure, standardization, but it was a standardization of dimensions. If the car frame were uniform a device of any patent could be used upon it. Thus we attained practical current convenience while preserving variety of design and material, of terms, delivery and dealings, and hence reasonable expedition in the demonstration and introduction of improvements.

We earnestly commend to your favorable consideration the fullest adherence to this method consistent with the most effective rehabilitation and maintenance of transportation facilities in face of the enemy. We are ready for any sacrifice essential to winning the war. We would deplore as disastrous to the nation's business any departure, not clearly necessary for national defense, from competition between patented railway appliances.

Manufacturers of railway goods have borne an honorable part in promoting the progress of transportation science. What they have achieved for the public in safety, comfort, speed and economy of railway operation has been accomplished in an atmosphere of keenest competition. We could try persuasion upon one independent railway manager after another until the test was made and a demonstration afforded. Our work has been marked by variety, elasticity, development. The inventor, the executive and the salesman have been in-

spired by the hope of excelling, roused to effort by the exertions of rivals. Under such conditions our industries and the country with them have progressed and thriven. The man with whom we have hitherto dealt has had a definite responsibility for affording his company the benefit of the latest scientific discoveries.

We believe that the preservation of decentralization in our dealings is not only important for the immediate present, but vital as a precedent for the ultimate adjustment after the war.

Looking especially to the present, many of those engaged in the railway supply industry are profoundly anxious concerning the policy which you will adopt as it may affect them and the scores of thousands of workers whom they employ.

Unofficial statements and rumors have hinted at the possibility of far-reaching standardization, under which large numbers of plants would be swept out of existence or forced to reorganize for some other type of service. A maker produces, let us say, a device which is part of a car. He is one of several who manufacture competing appliances that perform the same function. Will some one of us, he has been asking, be declared standard and all the others thrown into the discard? If so, the conclusion of peace would find the unfortunates whose products had been discarded under the edict of standardization for the period of the war deprived of a large part of the value of their patents through disuse and their business paralyzed through discontinuance of the mechanical and commercial processes which keep any business a progressive living organism.

Established commercial processes are the result of experience and of scrutiny under government regulation, federal and state. We are confident that you will be alert to the desirability of performing your difficult and vital function as Director General of Railroads with the least possible disturbance to those processes. We believe that you will find it practicable to preserve the business and the individuality of the several makers of rolling stock appliances. Cars have now been so far standardized in dimensions that they can travel over any railroad in the United States, as anyone can see who observes upon a freight train the multiplicity of ownership insignia. So far as speed of production is concerned little or no delay is occasioned in changing from one patent to another and substituting on each lot the appliances which have been designated by the particular buyer.

We can see no obstacle to the adoption of a plan under which, whatever the design of the car as a whole, every reputable established appliance for each function would be sanctioned and the several roads directed to exercise, as in the past, their judgment in specifying devices.

What applies to construction of new rolling stock is of more importance in the field of maintaining rolling stock that exists. The largest number of locomotives ever ordered for domestic account in any one year was 6,265. The number of locomotives in use and under maintenance according to the last report was 63,862. The largest number of freight cars ever ordered in any one year was 341,315. The number of freight cars in existence and requiring upkeep as last reported was 2,326,987. Obviously the big end of the rolling stock task and the preponderant consumption of engine and car parts is not in new construction but in maintenance. Apart from repairs made by one railroad upon cars found out of order on its rails a highly important proportion of such work is the thorough overhauling of cars by the road that owns them in its own shops. For replacement of parts broken or worn out each road orders from the makers quantities of whatever appliances are standard upon that road. Stability in the industry during the war will be promoted by permitting in general each road to determine as in the past which of the competing appliances it will use in repairs.

Such a policy, affecting both construction and repair upkeep, will not only give rapidity and certainty to the exigent performance in war and preserve for the time of peace the

commercial organizations which have carried on mechanical progress, but it will involve the minimum readjustment of shop operation and production quotas, thus keeping these enterprises in a strong position as payers of war taxes and subscribers to war bonds—these and the tradesmen and the people of the communities wherein their plants are located who draw sustenance primarily from the industrial pay roll.

Please permit me personally, and I believe I may say the same thing in my representative capacity, to felicitate you, Sir, upon your manifest determination to form judgments based upon knowledge and upon the opinion of those whose vocation fits them to serve the country through you at this crisis.

HONEYCOMB

Honeycomb, or flue sheet clinker, is due primarily to the presence in the coal of iron and sulphur impurities known as iron pyrites, or brasses. Contributing causes are lack of air in the firebox and insufficient time for the complete burning or oxidation of these impurities.

Eastern coal contains from 1 to 3 per cent, and Western coal as much as 10 to 12 per cent of this iron and sulphur mixture. Screenings and the finer parts of run-of-mine coal contain more of this substance than lump coal, and honeycomb trouble is most prolific when firing finely crushed coal.

When coal is thrown into the firebox the draft catches up the finer particles, and, if burned at all, they are burned in suspension while whirling through the firebox. If iron pyrites is present, it is decomposed by the heat at a temperature of 900 deg. F., giving off part of its sulphur and leaving a residue known as ferrous sulphide.

If this ferrous sulphide is brought into contact with sufficient oxygen and has time to burn completely, an infusible ash results; but if the oxygen supply is deficient, or the time available is not sufficient, a highly fusible substance known as ferrous oxide is formed. This is driven against the flue sheet in a pasty condition and sticks there. The building up of a slag on the flue sheet is accelerated by the fine particles of cinder and ash, which strike the sticky mass and adhere. It is then only a question of time until the clinker covers sufficient flues to cause a steam failure.

When the clinker first forms, it still contains some sulphur. Under the influence of the high firebox temperature, this sulphur volatilizes and, bubbling out as a gas, causes the "honeycomb" appearance which is responsible for its name.

It is impossible for most railroads to pick and choose coal that does not contain clinker-forming impurities. They must use the coal that is on or adjacent to their lines, regardless of its defects. If it contains honeycomb-forming impurities, it must be burned in such a manner as to overcome this difficulty.

Ample air supply must be maintained in the firebox. Large grate area is needed in order that the rate of combustion be kept low and the draft light. Thin fires and large nozzles should be used. All of the coal possible should be burned on the grates. Large air openings should be provided through the ashpan and grates.

Arches should be used to hold down and deflect the fine particles of coal and dust until they ignite and burn. These particles of coal and clinker-forming impurities must be thoroughly mixed with air and given time to burn. The arch forces this mixing to take place and gives a longer flamework and higher temperature to facilitate the burning. Combustion chambers are also necessary; and when used with the arch and sufficient air supply, will do much to eliminate honeycomb troubles.—*J. T. Anthony in the Erie Railroad Magazine.*



DEVELOPMENT OF THE STEEL CAR*

BY HENRY P. HOFFSTOT

Manager of Sales, Central District, Pressed Steel Car Company

A good many years ago some few all-steel cars were built and placed in operation by some of the steel companies and these cars are, I believe, still in service. The change from the use of wood to steel in the construction of coal cars in America was not brought about at one time but was extremely gradual in its development. In the early 90's C. T. Schoen commenced making pressed steel car shapes in his little plant in lower Allegheny and for years supplied the railroads with pressed steel center plates, side bearings, stake pockets, push pole pockets, etc., for use in connection with the construction of wooden cars. During the same time the Fox plant out on Penn avenue was furnishing pressed steel trucks and truck specialties to railroads for use on wooden equipment.

About 1895 Mr. Schoen conceived the idea of building steel cars on a large scale. The following year the first steel cars were ordered by the Pittsburgh, Bessemer & Lake Erie, and shortly after by the Pittsburgh & Western, and the Pittsburgh & Lake Erie. It is therefore to the foresight of the officers of these three companies that a great deal of the credit for the bringing about of the change from wood, or wooden cars with steel trucks and a few steel specialties to the all-steel car must be given. Mr. Schoen conceived the plan but in order to show the public it was necessary to find a buyer on whose railroad a demonstration of the cars in actual operation could be made. The heads of these three companies took the chance, and that they made no mistake in their judgment is now well recognized. The demand for this type of car grew rapidly. Its construction virtually revolutionized railroad traffic of this country. The first hopper cars were built to carry coal, and while stenciled 50-ton were hardly of 40-ton capacity so far as present M. C. B. requirements are concerned. Probably 85 to 90 per cent of these cars are still running after 20 years of service in and out of the Pittsburgh district, which with its bituminous coal and ore gives the car as severe service as could be received by them anywhere in this country. Since that time there has been an evolution in the construction of cars as great as that which took place in 1896 and 1897.

The railroads are continually demanding cars of heavier capacity so that the increasing volume of tonnage offered can more economically be handled on our congested railroads. Early in this century the combination of pressed steel and structural steel was used in car construction, and this is the type of construction most commonly used today. I am not here to discuss the benefits to be derived from the use of pressed steel over structural steel, or vice versa. Car companies are in the business of supplying a commodity to railroads and industrial concerns the same as a tailor is in the business to sell clothes to his customer. We sell what the customer wants.

There are steel cars and steel cars—some no better than wooden cars which will last under the treatment now given

to cars hardly as long as would good wooden cars—and there are steel cars the life of which as yet cannot be computed. Often an additional ton of steel carefully applied in the designing of the steel car will make the car so much stronger and better able to withhold the shocks and wear and tear received in unfair treatment to which we must expect a car to be subjected in the ordinary course of its life that by the end of 12 to 15 years it can be renovated at a comparatively small expense, while the car of poor design has long since undergone heavy repairs and may again be ready for more. In making this comparison it must be assumed that each type of car has undergone the same general treatment and been kept up in the way of painting and minor repairs in about an equal way. I make mention of this comparison not with the idea of passing along the blame for the failure of a particular type of car to the superintendent of motive power or mechanical engineer of the railroad involved who may have originally designed it, for I realize that in all probability it was the financial limitations of the railroad which limited him in the amount to be expended and that it was to keep within such limitations that he failed to authorize the use of the ton of additional steel which if put into the car at the beginning at an additional initial cost of possibly \$40 per car might have saved \$400 in rehabilitating the car later on.

100-TON CARS

Now the 70-ton car has come into general use, and several thousand 90-ton cars are in operation on at least one well known railroad which is also experimenting with a 100-ton car. The carrying of this huge tonnage has been made possible only through the use of steel in car construction. Heavier bridges, heavier rails, and heavier locomotives, etc., have all been required and are being put in to enable all roads to carry these heavier cars which have done so much toward reducing the cost per ton mile for handling materials and eliminating more or less of the congestion in our large terminals, for if the 30 and 40-ton cars of 20 years were still in operation, it would be necessary in order to carry the same tonnage to have trains anywhere from 20 to 30 per cent greater in length.

Many 100-ton coal cars are now in operation on short lines about the steel mills, and recently one of the railroads became interested in a 120-ton car. Its officers felt that the concentration of a 120-ton load in one car would not only shorten up the trains, thereby making a less number of units for a given train, but also a less number of operations in the dumping machines at the terminals, and would also reduce the number of wearing parts to be maintained as well as eliminate to a great extent the extra long sidings which would otherwise be required to handle the same tonnage in cars of lighter capacity. In other words, some of the general reasons which brought about the change from the 30 to 40-ton capacity wooden cars to 40 and 50-ton steel cars are now tending to bring about the use of very much heavier capacity steel cars. The officers of this particular railroad, fearful lest a mistake might be made in the ordering at the present time of a large number of cars in

*Presented before the Traffic Club of Pittsburgh.

which such a radical change would be made, elected to have four of the large car companies each build a sample car. The engineers of the railroad at that time supplied the car companies with the maximum height and width and approximate length which they felt would carry the required tonnage and left the details of the design of the cars to each of the car companies, their idea being to get these sample cars into actual service, and if experience showed that cars of 120-ton capacity could be more economically used than 50 or 70-ton cars, they would undoubtedly pick out the superior qualities from each of the four sample cars and design a car which in the opinion of their engineers would show as nearly as possible 100 per cent efficiency. These four cars have all been delivered, and are now receiving their trial, and it will be interesting to know the results. I believe that you will agree that this is a good way to get results.

THE STANDARD CAR

All of the car companies employ designing engineers who are at the top of their profession, and while I cannot speak for all of the companies, I can at least speak for the company which I represent and say that we at all times solicit an opportunity to help in the designing of steel and composite cars with a view not of exploiting any particular specialty or type of car, but solely with the view of bettering the steel car, always having in mind that the adoption of a car of standard design for the different classes will mean millions of dollars saved annually in the money expended by the railroads and indirectly by the American public in the first cost of cars and their maintenance. Certain rulings of the M. C. B. Association in the construction of all cars make it necessary to comply with certain regulations so far as clearances, strength, etc., are concerned. These rulings, however, do not go very far toward bringing about standard designs of cars. For many years this question has received more or less attention, and three or four years ago a committee of five builders was appointed by the railroad presidents representing the American Railway Association to go into the matter very carefully. Later ten or twelve railroad representatives were placed on this committee. After three years of labor they made their report and submitted specifications and blueprints covering box cars and gondola cars of several capacities. Shortly after this the committee was dissolved and the work I believe is now being continued in the hands of another committee appointed by the railroad presidents consisting entirely of railroad engineers. It will be interesting to watch the developments along this line, for it is the opinion of many that the greatest advance that can be made in steel car construction at this time will come with the adoption of cars of standard design for use all over the country.

No further progress along these lines can, however, be expected until Congress decides whether the railroads after the war are to remain the property of and be operated by their real owners under the control of an Interstate Commerce Commission, more liberal than heretofore in its views as to rates, or whether permanent government ownership and operation is to prevail.

Car companies are now in position to take orders and commence delivering cars within three months. If the conditions of this winter are not to be repeated next winter, hundreds of locomotives and thousands of cars must be ordered by some one for use on our American railroads to take care of replacements if nothing else. Let Congress act, then watch the 70-ton steel car develop.

STEAM LOCOMOTIVE EXPORTS.—During the month of December, 1917, says a recently issued bulletin of the National City Bank, locomotives were exported from the port of New York having a value of \$873,377.

IMPROVE THE CONDITION OF CARS

BY A SUPERINTENDENT OF MOTIVE POWER

There are thousands of cars built in the last few years which are of adequate strength and on which the appliances, such as truck frames, release riggings, draft gears, doors, roofs and ends are designed to meet present day requirements. Such cars are very seldom found on the repair tracks, and are giving excellent service. Freight car interchange will never reach the proper efficiency until minimum standards, covering these items, are prescribed and enforced, to prevent any railroads from building equipment which does not measure up to present day standards. I do not refer to detailed standards, but to standards of strength or operation. All of the above is but working for the protection of the future.

For the present, the following are some of the things which can be done:

One: Apply steel draft arms or steel underframes to wooden underframe cars when they receive general overhauling.

Two: Discontinue the maintenance of short door hasp fasteners, because these are a constant cause of tearing off the front edge of the door, and sending the car to the repair track. This has been known for years, and yet railroads keep right on applying the short fasteners.

Three: Sheathing is frequently re-nailed to decayed sills, which is a waste of time, and if a flat strip of iron or a light angle is applied outside of the sheathing and bolted through the sill, the repairs will be permanent. It is a general practice to use 2 1/2-in. nails for nailing sheathing to side sills, and I believe much better results would be obtained by using 3-in. nails.

Four: There are thousands of cars running with bottom door guides which lap the door only about 1 in. and without any metal protection on the bottom edge of the door. Such doors are a constant source of trouble, on account of coming out of the guides, and such cars should have deeper guides, and a metal edge on the bottom of the door.

Five: Frequently new box car doors are applied, which either rub against the end of the floor boards, or against the track, or hang down on the bottom guides, so that it is impossible to move the doors without the use of a bar. It is a waste of time to do such work, as the new door will simply be torn to pieces by the efforts to move it.

Six: Draft timbers and sill splices are applied which do not abut tightly at the ends.

Seven: End posts are applied which have the bottom corners chamfered off to get them into the pockets, and when the load goes up hard against the end of the car, these posts jump out of the pockets.

The above are only a few samples of poor work which is being done apparently at many of the car repair points in this country, and I doubt whether any railroad has a clean bill of health.

This is done in the effort to get the cars in service, but in my opinion, the ultimate purpose would be better served, by general effort to eliminate the above poor practices, and I think in a very few months the effect would be felt.

Each road dislikes to be the only road to start such a practice, as in some cases it means to hold a car longer to do a good job than it would be necessary to cobble it up, but in the first case the repairs are permanent, and in the second case, the car goes a few miles and then goes on the repair track again, often times on the same road which made the defective repairs in the first place.

Outside of a better quality of work, in order to make the repairs more permanent, the only other thing that I know of is, for the owning roads to strengthen the weak parts of their cars systematically whenever they have opportunity.

MICHIGAN CENTRAL REFRIGERATOR CAR

Particular Attention Has Been Given the Insulation; Free Circulation of Air in the Bunkers and Floor Permitted

A SHORT time ago the Michigan Central received 250 refrigerator cars which represent the latest development in the construction of this class of equipment. These cars were built by the Merchants Despatch Transportation Company at East Rochester, N. Y. They are 41 feet long and weigh 51,500 pounds, having a rated capacity of 70,000 pounds.

These cars are particularly well insulated, slab cork being used in the floors and below the sub-belt rail on the sides and ends. The sides are insulated with four layers of $\frac{1}{2}$ -in. insulation and the ceiling has five layers, the layers being applied with no air space between them. The method of insulating these cars was adopted after making extensive tests with the different methods of application. It was applied so as to eliminate as much as possible all dead air spaces. It has been found difficult to maintain a tight car with the courses of insulation separated, as the constant weaving of the car causes a circulation of air in the supposed

4's in. thick, and they extend from inside to inside of the side plates. Both the side and end plates and the side and end sills are mortised to receive the side posts and carlines.

The siding and the inside lining are 1 $\frac{1}{2}$ in. thick, and the flooring is 1 $\frac{3}{4}$ in. thick. Before applying the floor, the side framing is lined with a special waterproofing which extends from the inside face of the corner post to the door post and over the side sills at the door opening. This extends 16 in. up on the side framing. A layer of burlap plastic is then laid over the sills of the car and extends up 6 in. on the sides. Another layer of burlap plastic is laid over the 1 $\frac{3}{4}$ -in. flooring, extending up 6 in. on the car framing, and on top of this is placed the top course of flooring which is 13-16 in. thick.

The carlines are mortised into the side plates and are held in position by $\frac{1}{2}$ -in. tie rods, extending between the side plates and set flush with the face of the carline. The XLA outside metal roof, made by the Standard Railway Equip-

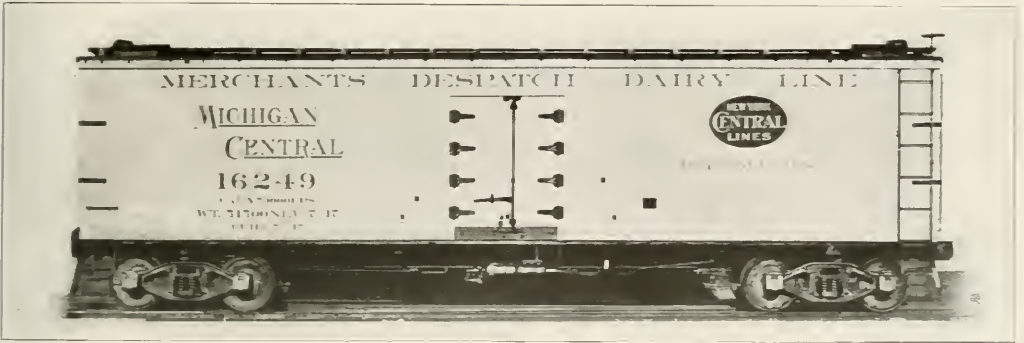

Refrigerator Car for the Michigan Central

dead air space. By placing the various courses of insulation close together, the construction of the car is simplified and the insulation can be supported better. The ice tanks are of M. D. T. standard construction, which was adopted a few years ago. The ice is held in wire screens in the inside of the tank. An air space of 2 in. is left between this screen and the walls of the tank on all sides, which permits free circulation of air around the ice and through the tanks to the base. An insulated bulkhead is used to prevent cooling of the perishable freight near the bulkhead to a lower temperature than is obtained in other parts of the car. Floor racks are provided to allow free circulation of the air under the lading.

UNDERFRAME AND SIDE FRAMING

These cars are provided with the Betendorf steel underframe, which is 41 ft. 4 $\frac{3}{4}$ in. over end sills. This underframe supports two side sills and six intermediate sills 5 $\frac{1}{2}$ in. wide by 4 in. thick. The end sills are of oak, being 6 in. wide by 4 in. thick. The side posts, end posts and diagonal braces are all 4 $\frac{1}{4}$ in. by 2 in. Three-quarter inch diagonal rods cross-cross the diagonal braces, as indicated in the drawings. The belt rails and cripples are made of the same material as the posts and braces. The side plates are 6 $\frac{1}{2}$ in. wide by 4 $\frac{1}{2}$ in. thick. The end plates are 12 $\frac{1}{2}$ in. wide by

4 $\frac{1}{2}$ in. thick, and they extend from inside to inside of the side plates. Both the side and end plates and the side and end sills are mortised to receive the side posts and carlines.

INSULATION

The insulation in the floor is made up of 2-in. corkboard laid on a 13-16-in. false floor between the sills. The cork is held in place by 1-in. nailing strips. Zero compound is then placed over the cork, making a perfect seal.

The outside of the car framing is covered with a layer of $\frac{3}{8}$ -in. shiplap pine. Over this is applied a layer of three-ply 90-lb. waterproof paper extending from side sill to side plate. Sub-belt rails 2 $\frac{1}{2}$ in. by 1 $\frac{3}{4}$ in. are then applied over the belt rails. Between the lower sub-belt rail and the side sill 2-in. corkboard is applied, the faces of the board being dipped in hot Hydrex compound before being applied. The four-ply, $\frac{1}{2}$ -in. insulation is applied en masse between the belt rails and the side plates. The insulation is held in place by $\frac{1}{4}$ -in. round nailing strips. Battens are placed at each intermediate post, corner post, door post and belt rails and an additional batten is applied in each panel formed by the vertical battens, belt rails and side plate filler to more securely support the insulation. Two-ply wool felt is applied immediately on top of the battens, and on top of this is applied a layer of three-ply, 90-lb. waterproof paper extending from the top of the side plate to the bottom of the side

sill and from door post to door post around the ends of the car. The siding is applied on top of this.

The roof of the car is insulated with five layers of 1/2-in. insulation applied to a 3/8-in. false ceiling, separated from the ceiling by 1-in. by 1-in. nailing strips. This insulation

rear and the malleable iron casting at the front. The ice grates are 2 3/4 in. by 2 3/4 in. by 1/4 in. galvanized angles set with the corner up, as indicated in the drawings. The bulkhead is supported on a galvanized 5-in. by 3 1/2-in. by 3/8-in. angle, which is bolted to the malleable base casting. There

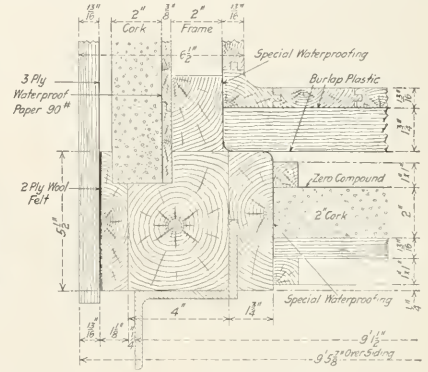
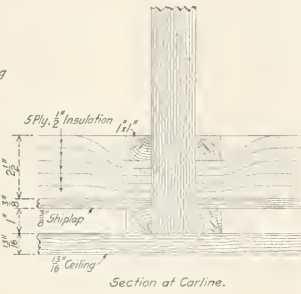
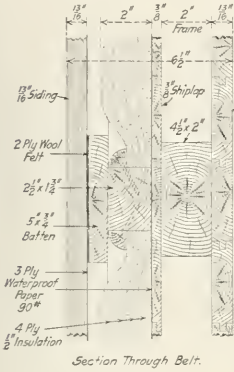

Various Sections Showing Application of Insulation

is held in place by 1-in. by 1-in. nailing strips, as indicated in the illustrations. A layer of burlap plastic is applied between the metal roof and the roof boards.

ICE COMPARTMENTS

The ice compartments are 3 ft. long by 7 ft. 11 in. wide. The sides and ends of the car are lined with No. 24 gal-

vanized iron to a height of 2-in. by 2-in. by 1/4-in. galvanized angles, which are riveted to the bulkhead base at the bottom and bolted to a reinforcing angle through the ceiling at the top. To the intermediate bulkhead posts are bolted 2-in. by 2 1/4-in. furring strips, on which is laid a 13-16-in. bulkhead lining. Four layers of 1/2-in. insulation protect the lading next the bulkhead from too low temperature.

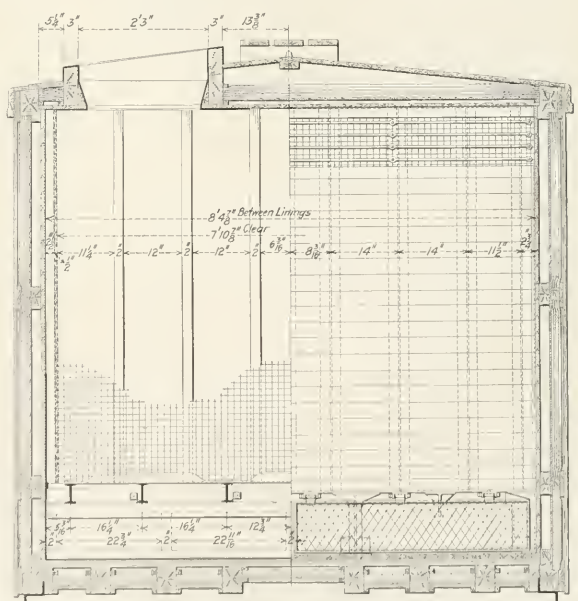
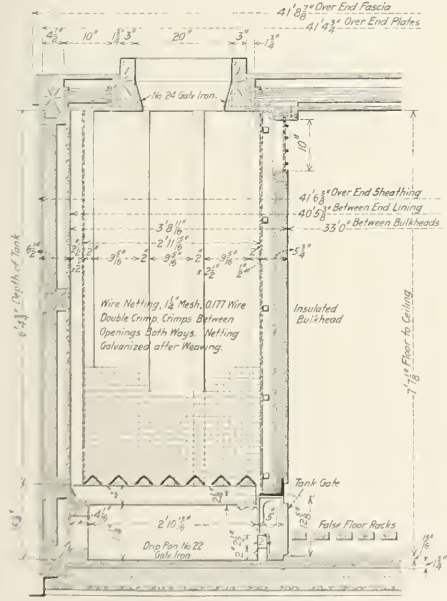

Arrangement and Design of Ice Compartments, Michigan Central Refrigerator Car

vanized iron to a height of 30 in. The ice grate frame is made up of malleable iron and commercial shapes. There are six 4-in., 7.5-lb., galvanized I-beam supports for the grate bars which rest on a 1 1-16-in., 10 3-10-lb. Z-bar at the

The bulkhead top rail is 2 in. by 2 in., extending the full width of the bulkhead, being nailed to the bulkhead post furring strips. The outside lining is 13/16 in., which is nailed to 2-in. by 2-in. furring strips in the bulkhead. An

opening 10 in. wide is provided at the top and an opening 12 5/8 in. wide is provided at the bottom of the bulkhead.

The tank screen is made up of 0.177 wire with a 1/4-in. mesh. The netting on the side and rear of the tank is fastened to oak furring strips and at the front it is secured to the bulkhead post furring strips. The tank covers are insulated with four layers of 1/2-in. insulation. The openings in the roof are 20 in. by 27 in.

The opening at the bottom of the bulkhead is covered with a gate of 1 1/2-in. diamond mesh made up of 0.177 wire, which is mounted on a frame of 7/8-in. by 7/16-in. channels. These gates are fastened to the angle bulkhead support by

HOT BOXES ON FREIGHT CARS

BY F. W. SCHULTZ

District Foreman, Union Pacific, Grand Island, Neb.

The first and most conspicuous cause of hot boxes is inattention. It is too bad there is so much waste of oil on a poor bearing. If a bearing has been overheated all the oil in the country will not save it. It is then significant that a little mechanical ingenuity is necessary. It sometimes does not require a great deal of mechanical ingenuity to put a bearing in the proper condition. The fact that a bearing has been running in good condition indicates the mechanical construction is all right. If it is then not given attention and there is any lack of lubrication, the bearing will soon be destroyed. I venture to say inattention is practically the first and only cause of a bearing being heated, and is mostly the cause out and out of hot boxes on freight cars, or any other equipment. There is no question but what a large amount of oil is wasted; therefore the handling of packing and inspection of boxes on freight cars should be systematic.

There should be no reason why a card case could not be applied to a box car in a conspicuous place, and made uniform throughout the country, to carry a card showing the last time boxes were inspected, packed, or oiled. This is equally as important as the stenciling of a triple. If cards are applied in this case and were uniform throughout the country the same as other M. C. B. cards, there is no reason why journal box lubrication would not be given the same attention. Oil would be saved, as there is no doubt but that many times oil is applied when it is not necessary, also boxes would then be systematically inspected, packed and oiled.

It is commonly known that cars have been taken from industrial tracks where they have stood for several months; likewise cars that have been stored which have had all packing robbed from boxes, and put in trains without any attention. There has been no packing to burn, or smoke, and journals have burnt off, where if cards in card cases were noted by trainmen, or inspectors, the journal boxes, no doubt, would be given attention. It is easier to look at one card than eight journal boxes. The same car on an industrial track without an air hose would be immediately supplied, and a car would not be taken, either empty or under load, without an air hose. Usually this car is put on the head end of a train account of making time in switching, which is in the most dangerous place in the event a journal is burnt off.

To prevent journal failures no journal should be allowed to run if it has been red hot, as this journal when car is stopped is usually sprung. Many cars have been set out of trains along the road with a red hot bearing with a journal sprung, and car men will be sent to rebrass and repack, or apply a journal box and a water cooler. This same journal, no doubt, has never been reported as being red hot, and has not been noticed until it has gone to the lathe.

If this journal, regardless of how badly it has been sprung, will true up within the limit, it is usually put in service again. Fractures will invariably occur, and many times never discovered. This is why there are so many smooth journal ends setting in laboratories to be analyzed, and many trainmen have lost their jobs because a journal has been found in the end of a box which showed no heating except the heating from the stub end of the axle, which carried the journal box. This caused the burning of packing and the grinding up of the brass, the only thing left being a good smooth end of the journal in the journal box.

The necessary attention will undoubtedly eliminate hot boxes.

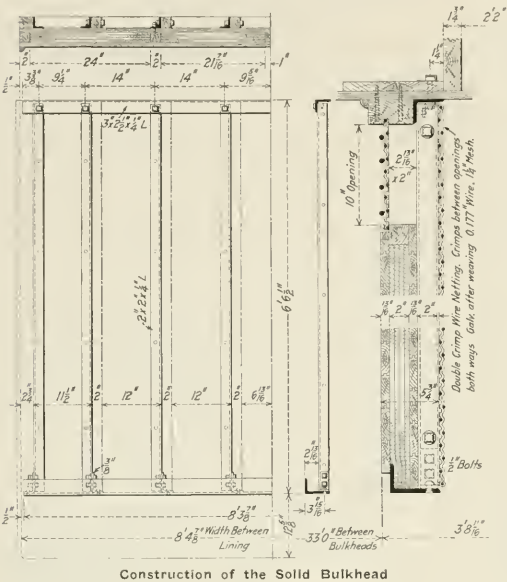

hinges. At the top a similar netting is used with four 1/2-in. rods applied as indicated in the drawings.

Among the specialties used on this car may be mentioned Miner roller side bearings, Western angle cock holder and card holder, Bettendorf trucks and Virginia dust guards.

The following are the general dimensions of this car:

Length over end sills	41 ft. 4 3/4 in.
Length inside of lining	40 ft. 5 3/8 in.
Distance between ice tanks	9 ft. 3 3/8 in.
Width over outside sheathing	9 ft. 5 7/8 in.
Width inside of lining	8 ft. 4 7/8 in.
Width over side fascia	9 ft. 9 1/8 in.
Width of door opening	5 ft. 5 in.
Height from rail to eaves	12 ft. 2 1/2 in.
Height from rail to over all	13 ft. 8 5/8 in.
Height from top of floor to ceiling	7 ft. 7 1/2 in.
Cubic feet capacity	2,026

PIPE LINE TRAFFIC IN DECEMBER.—The United States Geological Survey has issued a statement compiled from data received from 180 pipe line and refining companies that handle or receive oil direct from the productive fields east of the Rocky Mountains, showing that in December 1917, 19,867,143 barrels of crude petroleum were moved from field sources. The stocks of crude petroleum on hand at the end of December were 129,232,811 barrels. Statistics of petroleum movement in California are not included because of delays incident to procuring first-hand data. Except in the Oklahoma-Kansas field, the surface reserve of crude oil at the end of 1917 was appreciably less than at the end of 1916.

THE NEED OF A BUSINESS BOX CAR*

Commercial Functions Should Be Considered with
Mechanical Details. Better Designs Are Necessary

BY W. J. BOHAN

Mechanical Engineer, Northern Pacific

IT is my intention to offer a few remarks on the business of a box car and the relation of its construction thereto. I am taking the box car, as that type appears most frequently in interchange, and is probably receiving the greatest attention at the present time. An impression of the importance of box cars as they affect dividends can be gained from the following facts:

A total of 261,100 box cars were owned and operated by eight leading western and northwestern railroads during the last year, or an average per road of approximately 32,600. The total number of box cars represents 50.7 per cent of the total freight cars owned by these roads. These box cars may fairly be said to represent an original investment of \$210,000,000.

The average total cost of repairs per road per year for a four-year period for all classes of cars was \$3,481,000. The average cost of repairs per car per year was \$64. The minimum cost per car per year for one of the roads was \$41. The maximum cost per car per year was \$110, a difference between minimum and maximum cost per car per year of \$69, or \$5 more than the average cost of repairs per car per year for all the roads mentioned.

The character of transportation on each of these roads is the same and the ratio of the number of box cars to the total number of freight cars of all classes is very nearly the same. It is fair to assume for the purpose of this paper that the above repair cost ratios for the different roads would obtain for box cars.

The claims paid for losses due to grain leakage by a large grain carrying line of the same group of roads for four years ending in 1917, averaged \$80,000 per year, grain being carried in both owned and foreign cars. The average damage claims paid per year on account of defective equipment on all commodities other than grain for the same period was \$17,000.

A stockholder of an inquiring turn of mind, or the president of one of these railroads, in view of the high loss and damage costs and wide difference in repair figures, would be justified in asking, "What is the matter?" Several things are the matter, and one of them is undoubtedly lack of business balance in car construction—box car construction—that being the type of car under consideration.

IMPROVED BOX CAR DESIGN NEEDED

For years mental and physical energy have been spent on box car design by the best and most loyal of men both technical and practical, and a generally satisfactory box car is not yet with us.

Have we kept it back by a flux of figures on stresses and strains lacking the leaven of sound engineering judgment? Have we delayed its coming by building upon too narrow conceptions of the problem? Have we co-operated with each other sufficiently in treating a large subject in a large way, by exerting our energies toward a broad and careful analysis of the subject, with a full realization that box cars are business agents of the railroads that own them, and that their dividend earning capacity depends upon their commercial efficiency as well as upon their mechanical details, and have we realized that the two qualifications are correlated? The

fact that we haven't the generally satisfactory box car indicates at least that the progress of its development has been slow. The time has arrived when we must develop an efficient box car in its fullest sense. The unusual volume of business, the shortage of equipment, the scarcity of labor and material with the constantly upward trend in the prices of both, demand it. What have we got to offer in the way of a business box car?

The business box car must be free from leakage of lading, it must be weather-proof and practically fire-proof, it must have a so-called non-sweating interior free from projections and pockets, it must have properly dimensioned door openings and substantial free positive functioning doors and fastenings, and be so constructed as to lend itself to diversified lading with the incidental supplementary doors, blocking, etc. In short, it must be a car popular with the shipper—a dividend earning unit having a maximum demand.

It must, in addition to these qualities, have a minimum light weight, a maximum utility and carrying capacity per unit of weight, reasonable first cost, and freedom from mechanical defects. Two principal elements enter into the design and construction of such a car. First, accurate technical engineering information, and second sound, practical business judgment based upon experience, the latter largely predominating for the reason that evidence is lacking that anyone ever reduced the things that happen to a box car to conclusive figures.

In a recent article in one of the railway magazines a statement was made that in train service the car body has three movements, all of which absorb a part of the force applied at the couplers. This is true as far as it goes, and if this were all, figuring would be comparatively easy. It, however, stops where the real trouble begins. The fact of the matter is that the box car is subject not only to these three forces, but the resultant of their combined action and many others of such varying direction, intensity and rapidity of occurrence that their accurate mathematical determination is out of the question. Among these forces may be mentioned those due to poorly balanced designs, unevenness of track, curvature, centrifugal force, train handling, draft action, irregular lading, the shifting of lading, varying atmospheric conditions, etc.

Briefly, all of these forces combine in what may be called "team work" against the life of the box car. Close observation and experience with a large number of different types of box cars indicates that the general and greatest result of this team work manifests itself in twisting the car. Such being the case, then team work in an opposing direction by the various members of the car must be the natural antidote.

I believe the most economically efficient box car to be one in which every detail, even the grab iron, is made to do its fair share in assisting the natural functions of the car and resisting the stress and abuse to which it is exposed. The body of such a car should not be built around any one member, but all of its members should form a unit having maximum inherent strength and resilience and acting as a unit in dissipating all reasonable strain action. It should have the fewest possible primary and special parts in that joints, gussets, rivets, bolts and fastenings which work and

*Abstract of a paper presented at the Western Railway Club.

wear to the detriment of the car, increase its cost of up-keep and cause a considerable loss of time on repair tracks.

GENERAL SPECIFICATIONS

A general specification for a car that would meet the requirements outlined would be briefly as follows:

The weight for a 40-ft. 40-ton box car should be between 45 and 50 per cent of the stenciled capacity. I should say it should not exceed 48 per cent. This weight can be obtained without sacrifice of strength.

The body should be steel framed throughout, preferably of pressed steel of resilient quality. The underframe, sides, ends and roof should be diagonally braced throughout. There is no question about the efficiency of diagonal bracing. Its value has been many times demonstrated in the reclamation of thousands of old cars. As the diagonal bracing of the entire construction will distribute the strains due to the live load and shocks to all members of the car, the fish belly type of center construction is not necessary. Center sills ten inches deep and of ordinary cross section are sufficient.

The side and end posts and braces, at the points of attachment with sills and plates, underframe bracing at the points of attachment with center and side sills, and roof bracing at the points of attachment with ridge pole and plates, should be directly connected, that is, the usual construction using gusset plates or other secondary members should be eliminated as the strength and efficiency of the car can be materially increased by so doing, and unnecessary parts eliminated. Autogenous welding may be used to material advantage in such a construction.

The diagonal underframe bracing at the ends should be securely tied to both the center and end sills at their junction, and extend continuously around the ends of the body bolster and cross ties, with alternate connections to the center and side sills. The same general construction may be followed in the roof for the attachments of the diagonal bracing and plates, ridge pole and door carlines. At the door openings the underframe should be substantially reinforced by supplementary diagonal bracing. The plate may be similarly reinforced above the door, or the door track constructed to form the reinforcement. The roof reinforcement at the door openings may be made by the use of carlines at the door posts. The end construction with its attachment to end sills and plates should be similar to the side construction.

The corner posts should be formed by directly connecting the end side post and side end post members throughout their entire length. This will not only tie the car together securely but it materially assists in forming an integral construction. The corners may be further reinforced by continuous corner and end grab irons. The side and end sheathing should be constructed of two sections of sheet steel, their junction reinforced by plates, and all securely riveted together forming side and end girths, the girth reinforcing plate extending continuously from side door post to side door post around the end of the car. The end and side lining should be of matched lumber, the sides $\frac{3}{4}$ in. or $1\frac{1}{16}$ in. thick, the ends $1\frac{3}{4}$ in. thick, the lining extending from floor to plates. The floor may be of the usual $1\frac{3}{4}$ in. matched stock secured to furring strips on the underframe, using standard grain strips at the intersections of the floor and the sheathing.

The roof should be of the circular type and may be constructed of two sheets of No. 16 steel running lengthwise of the car, with a joint at the ridge pole, the two roof sheets being securely riveted between the ridge-pole and a weather proof ridge-pole cap. The roof sheets should also be securely riveted to the diagonal braces, end and side plates, thus forming an integral member of the car capable of sustaining its share of the load. It is necessary that the

inside of the roof be what is commonly called "non-sweating." This can be taken care of by the application of a heavy coat of ground cork and red lead or mineral paint applied to the exposed metal surfaces.

The door should be of steel, framed and sheathed similar to the body of the car, and mounted with weather-proof shields at the posts and plates.

The truck should, like the body, have as few parts as possible and be preferably of the cast steel type. Particular attention should be given the brake beam mounting to insure even brake shoe wear and proper alinement of levers and rods. All of these points are of extreme importance not only in that they may perform their special functions properly, but that irregular transmission of stresses to the car itself be avoided as far as possible. Brake equipment of standard makes is quite satisfactory. Special attention, usually lacking, to secure proper application and alinement of parts, is absolutely necessary to obtain safe and efficient results.

The draft gear should be of the friction type having a minimum recoil action, which should be just sufficient to readjust the parts in release. The travel should be approximately four inches. The shock dissipating capacity should be the maximum obtainable with prescribed travel and standard clearance conditions. The draft lug fastenings should approach strength sufficient to resist the maximum shocks regardless of draft gear capacity.

The holes in the framing should be die punched to temp-lets. All rivets and bolts should be of the best quality obtainable and of dull cross section. Bolts should have properly proportioned heads and clean cut and accurate threads to provide for wrench fit of nuts. Nuts should also be of the best quality and manufacture. The application of both rivets and bolts should be made without drifting, rivets having full and concentric heads and driven at the proper temperature.

Double nuts, lock nuts, cotters and split keys where used should be given special attention. I consider a good design of nut lock superior to a cotter or split key on account of the extreme difficulty in getting proper application of cotters or split keys. No one little thing is a source of more trouble on a car than loose nuts.

Too much stress cannot be placed upon the importance of more careful practical engineering study of both general and detail design to secure a well balanced, resilient car unit. Some manufacturers have done a great deal of excellent work in this direction on underframes, but have not in my opinion extended the resilient features far enough, as there is no reason why it should not extend to the entire superstructure. Particular attention should also be given to the selection and assembly of the best material that can be obtained.

In conclusion, it must always be borne in mind that the most efficient business box car is one so constructed and assembled that it will afford a maximum resistance to the development of chronic conditions arising from general and not maximum service stress. Such a car, reasonably maintained, will have the physical strength to take care of reasonable maximum stresses and at the same time represent a minimum first cost and up-keep, and be commercially efficient.

DISCUSSION

W. G. Wallace (American Steel Foundries): The M. C. B. couplers provide for angling of 15 deg. with a total side clearance of couplers of $2\frac{1}{2}$ in., giving $1\frac{1}{4}$ in. on either side of the coupler shank between the legs of the striking casting. With the coupler yoke and draft gear attachments when the overhang or the distance between the center line of bolster and pulling face of the coupler is of such length that the length of car and the curvature of track will bring

the couplers so far from the center of the track that the present angling will not permit of free movement, but binds the couplers, distorting guard arms, split faces and exerts a pressure between the sills tending to spread them apart and in some cases breaking the striking castings by reason of the pressure applied sideways. This puts a strain on the center sills, increases the pressure of the flanges against the rails, also the train resistance and in a measure increases the liability of derailment. If you will observe some of the cars of recent construction, you will find many of them have the striking castings with the lugs projecting on either side of the coupling, you will find them all split and distorted and broken and it looks to me that when you do not provide that proper angle, with your heavy tonnage train and motive power, that you are putting the stress in that car that, if it could be reasonably avoided, it would be advantageous to do so.

G. S. Goodwin (C., R. I. & P. Ry.): I notice the author says, "The body should be steel frame throughout. . . . The underframe, sides, ends and roof should be diagonally braced throughout. There is no question about the efficiency of diagonal bracing."

I agree with the author on the efficiency of diagonal bracing, but I want to recall a little experience I had several years ago with a 50-ft. steel frame furniture car. The car had fish-belly sills designed to carry the entire load, so that the steel side frame had only to prevent the sides bulging. The car was 10 ft. high inside, and the roof was diagonally braced. The cars derailed in the yard, and in going into the matter we found, due to the extreme distance between the trucks, that on a curve one truck might be elevated on one side considerably more than the other. This brought the diagonal side bearings into contact, and since the body of the car could not twist on account of the diagonal bracing in the roof, and the truck was stiff, the car derailed. We proved the tendency of the body of the car to twist by cutting one of the braces when the car stood on a curve. It opened up about 1½ in. Since that experience I try to analyze the effect of the diagonal bracing before I use it. The distance between side bearing centers on this car was 60 in., center to center.

Mr. Bohan: I consider 60 in. too much. I do not believe that a car having a free working truck of reasonably good design can be derailed under ordinary conditions if the load remains on the center plate. I have recently seen some new refrigerator cars equipped with roller side bearings spaced 60 in. center derailed on rough straight track or on curves improperly elevated, as fast as they could be rerailed. In all cases the load was lifted from the center plates and transferred to diagonally opposite side bearings, unloading the wheels on the opposite sides of the trucks. The trouble was corrected in the particular case in mind by increasing the side bearing clearance to compensate for the irregular track or improperly elevated curves. I have until recently considered 56 in. between side bearings sufficient, but I am now convinced that 48 to 54 in. would be better.

E. G. Chenoweth (C., R. I. & P.): I want to add a word relative to the car that Mr. Goodwin spoke of, especially in reference to the location of side bearings of the car that derailed. This car, in order to ascertain just what was the cause of the derailment, had its side bearings applied very close to the center plate, as close as possible, then it was moved out toward the end of the bolster a few inches at a time and tested each time to see if it would derail. No location of side bearing stopped the derailing. The side bearing clearance was changed and it still derailed. After that we took the side bearings off entirely and the car still derailed. Therefore it is my belief that in some equipment the side bearing has nothing whatever to do with the derailment. It is due to something else entirely.

Robert Quayle (C. & N. W.): There is a suggestion in

the paper as to the relative cost of maintenance of cars. I think it is hardly fair to assume that you can have an equal cost on all roads, even though the cars may be of the same design and construction. Here is a railroad that will not change its trains for perhaps 500 miles or more, and some other railroad will have to change that train every 30 or 40 miles. The effect of the switching is magnified and the effect on the framing is intensified. The results you know. If you can get along with very little switching, you are going to get along with very little cost of maintenance. The topography of the road has much to do with the maintenance of cars and equipment.

I think it would be a good thing for us to have a standard car and I am willing to vote for something of that kind. I am willing to throw away a good many of my notions, they may be old foggy, some of them are. I will exchange my views with yours and I will swap something with you and then the East and West, North and South, can get a car that will answer our purposes very well and give the service required. I am willing to do it and we ought to be patriotic along that line, just the same as we now cover all sectional divisions and we are all Americans, fighting for one thing, democracy and the liberty of humanity.

RUN REPAIR OR TRANSFER*

BY F. W. TRAPNELL

Chief Interchange Inspector, Kansas City, Mo.

Having been asked to write a paper on some live topic, I chose the above after I read the article under the above caption in the *Railway Mechanical Engineer* of January issue which reads:

"The transfer of loaded cars in large terminals has become a live issue in these times of shortage of equipment, and some advocate the ancient custom of Run Repair or Transfer, at receiving line expense."

The above would be all right if all equipment were in equal condition, but we do not find that to be the case and to go back to that old obsolete rule would cause a great deal more transferring than is done now, as the originating line would not pay any attention to the vehicle that is loaded because the receiving line would have to assume all the expense even with the penalty attached of paying for the transfer. Some roads are not giving any attention to the condition of the car that is set for loading and then complain of the number of transfers allowed against them, where if the proper care had been given the cars before loading, the transfers would be cut down 80 per cent. A great many cars are repaired, splicing draft sills and putting on end sills, etc., in loaded cars, that can be done where the car is loaded so that such repairs can be made, but there is a vast number of cars that the commodity has to be one-third to one-half unloaded to get at the work, in that case it would be expediting the freight to transfer it. The receiving line not being responsible for the condition of the car, they should not be held responsible for the transfer, or in other words, penalized for the carelessness of the originating line in not loading a good order car. M. C. B. Rule No. 2 is really a run repair or transfer rule, it outlining the defects that must be repaired while car is loaded and moved forward. Should the line receiving not wish to repair these defects, they do the transferring at their own expense.

The best way to economize is to see that the vehicle is in proper shape before loading and if not repair it. This will eliminate many load transfers and save considerable time. As it is, any car that happens to be handy is usually sent

*From a paper presented before the Southwestern Carmen's Club of Kansas City.

to a plant for a load and no attention is paid to its physical condition.

Proper supervision is not given to the loading of cars; they are loaded without door protection, allowing doors to bulge out and get off the track or out of the guides. Gondolas are not properly loaded, the load being allowed to shift to one side, contributing to the derailment of cars. Loads on other cars are not properly staked or blocked, or the bearing piece is improperly applied. The shippers should be furnished with a book of the loading rules and made to comply with them. This would be a good investment to the railroad company.

And where any transfer order is issued a statement should be made showing where the car was billed from and where to, with such other information as would help the general officers to get after the point of origin and get the agent lined up on the loading so as to save the expense of transfer or adjustment.

STRESSES IN BOLTS IN FULCRUM BRACKETS

BY VICTOR M. SUMMA

The design of bolted fastenings subject to heavy stresses, such as the fulcrum brackets for brake bell cranks and similar parts, at first sight seems to present little difficulty. In certain types of brackets, however, there are combinations of stresses, the resultant of which is by no means easy to determine. Designers sometimes fail to take account of the secondary stresses in such members, with the result that the bolts are stressed beyond the elastic limit, making it necessary to replace them at frequent intervals.

The general principles involved in the design of brake

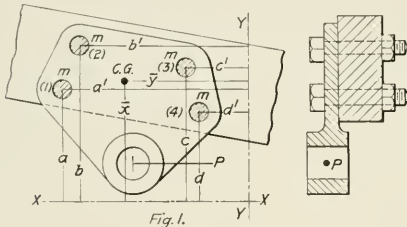

fulcrum brackets are of such wide application that it may be of interest to analyze a few typical cases. The fastening of the bracket shown in Fig. 1 is one of the simplest forms. The bolts are all in one plane and there is no shoulder to assist in holding the part in position. A bracket held in this way will tend to revolve about the center of gravity of the bolts and in calculating the stresses, this point must first be found. This can readily be done by taking two axes at right angles. The distance from each axis to the center of each bolt is measured and multiplied by the area of the bolt. The sum of the products is then divided by the total area of the bolts, which will give the distance of the center of gravity from the axis. Thus in Fig. 1 if the area of each bolt is M and the distance from the axis respectively a, b, c and d , the distance of the center of gravity, from the axis xx will be

$$\frac{am + bm + cm + dm}{4m}$$

In the same way the distance of the center of gravity from the axis yy can be found.

This relation can be expressed by the general formulæ

$$x = \frac{\sum mx}{\sum m} \text{ and } y = \frac{\sum my}{\sum m}$$

in which x and y are the respective distances of the center of gravity from the two co-ordinate axes, $\sum mx$ and $\sum my$ are the products of the areas of the bolts by the distances from the axes and $\sum m$ is the total area of the sections of the bolts.

The condition of equilibrium under the force P , acting at the center of the hub, is shown in Fig. 2, in which the individual resistances of the bolts are marked p and $Q1, Q2, Q3$ and $Q4$. The reaction p for each bolt must be parallel to P and equal to $\frac{P}{n}$, where n is the number of

bolts in the flange. The forces $Q1, Q2$, etc., which counteract the moments of the force P , about the center of gravity

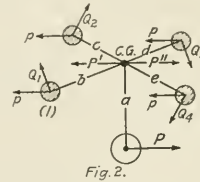

(Pa) act at right angles to the arms b, c, d and e , as indicated in the diagram. It will also be readily seen that if $Q1$ is the resistance offered by the bolt farthest from the center of gravity, the resistance offered by the other bolts will be smaller in proportion to their respective distances from the origin, or center of gravity. In other words, if Q represents the resistance at unit distance, the actual resistance of the bolts at distances b, c, d and e will be Qb, Qc, Qd and Qe .

Equating the moments of these forces about the center of gravity to the amount of the force Q , we have

$$Pa = Qb^2 + Qc^2 + Qd^2 + Qe^2 = Q(b^2 + c^2 + d^2 + e^2)$$

or,

$$Q = \frac{Pa}{b^2 + c^2 + d^2 + e^2}$$

From this we can derive the formulæ for the secondary resistance of the bolts.

$$Qb = \frac{Pa \times b}{b^2 + c^2 + d^2 + e^2}$$

$$Qc = \frac{Pa \times c}{b^2 + c^2 + d^2 + e^2}, \text{ etc.}$$

The principle illustrated by these formulæ may be stated in the following general rule: To find the total secondary

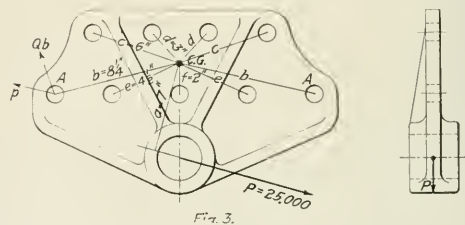

stress of each bolt or rivet divide the moment of the given force P about the center of rotation (in this case the center of gravity of the bolts) by the sum of the squares of the distances of the bolts from the center of rotation, and multiply the result by the distance of the bolt under investigation from the center of rotation.

By the composition of forces the resultant of each of the secondary resistances and the direct resistance, p , can be

found, which will give the resultant load to be carried by the bolts.

A few examples taken from actual practice will give an idea of the value of the principles just discussed to the designing engineer.

Example 1.—It is required to find the unit stress in the most strained bolt in the fulcrum bracket for locomotive

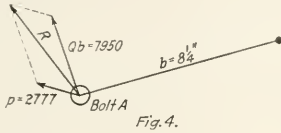

driver brakes shown in the sketch (Fig. 3). The bolts are all 3/4 in. in diameter and the force *P* at the hub is 25,000 lb.

The greatest stress will obviously occur in bolts *A*. Then: Direct resistance ==

$$p = \frac{P}{n} = \frac{25,000}{9} = 2,777 \text{ lb.}$$

Secondary resistance ==

$$Qb = \frac{Pa \times b}{2b^2 + 2c^2 + 2d^2 + 2e^2 + 2f^2}$$

The distance from the center of gravity of the bolts to the line of action of the force *P* is found to be 7 inches. Then,

$$Qb = \frac{25,000 \times 7 \times 8.25}{2 \times 8.25^2 + 2 \times 6^2 + 2 \times 3^2 + 2 \times 4.5^2 + 2^2} = \frac{25,000 \times 7 \times 8.25}{182.31} = 7,950 \text{ lb.}$$

By graphics, as indicated in Fig. 4, the resultant, *R*, is found to be 8,740 lb., from which the shearing unit-stress is

$$v = \frac{8740}{0.44} = 19,800 \text{ lb. per sq. in.}$$

Example 2.—In Fig. 5 is shown a familiar design of corner connections. A force *P* (9,000 lb.) is transmitted

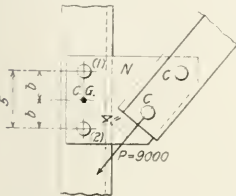

Fig. 5.

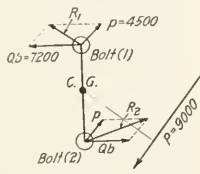

Fig. 6.

to plate *N* through the rivets *C*. Find the stresses in rivets (1) and (2), their diameter being 7/8 in.

The center of gravity of rivets (1) and (2) is, of course, the middle point of their pitch-distance, i.e. 2 1/2 in. from each rivet. The arm of the moment *P* about the center of gravity is 4 in. Then, as before—

Direct resistance ==

$$p = \frac{P}{n} = \frac{9,000}{2} = 4,500 \text{ lb.}$$

Secondary resistance (alike in both rivets) ==

$$Qb = \frac{Pa \times b}{2 \times b^2} = \frac{9000 \times 4 \times 2.5}{2 \times 2.5^2}$$

and their two resultants (see Fig. 6) are—

$$R1 = 5,270 \text{ lb.; } R2 = 10,560 \text{ lb.}$$

or unit stress in rivet

$$f = \frac{5270}{0.6} = 8,700 \text{ lb. per sq. in.}$$

unit stress in rivet

$$(2) = \frac{10,900}{0.6} = 18,200 \text{ lb. per sq. in.}$$

In the solution of such problems as these the mistake is often made of assuming the wrong direction for the force *p* or *Qb*. It should be borne in mind that the resistances offered by the bolts, being reactions of the force *P* and the couple *Pa*, always act in the direction opposite to the action of these forces.

In Fig. 7 is shown one type of bracket extensively used on locomotives as a shaft support in the brake rigging. The fulcrum of the cylinder lever is at the point *M* and in this case the reaction, *P*, of the air pressure and the pull at the connection rod is 50,000 lb. Under the action of the force *P* the bracket tends to slide along the frame and also to turn about the line *OO*. It is obvious that the force *P* has also a tendency to turn the bracket about the line *KK* which

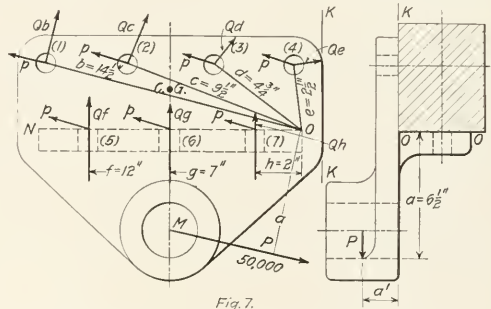

Fig. 7.

must be considered. It is required to find the intensity of the stresses in the bolts due to this force, *P*.

The direct resistance of each bolt to the force *P* is evidently

$$\frac{50,000}{7} = 7,140 \text{ lb.}$$

indicated in the sketch by the letter *p*. The forces produced in the bolts by the turning moments of the couple *Pa* about *OO*, will oppose to *Pa*, not their moments about the center of the gravity of the bolts, but their moments about the edge *OO*, around which the casting is bound to revolve. Also, if *Q* is the resistance to unit distance, and *b, c, h*, the corresponding distances of each bolt from *O-O*, the actual resistances offered by the bolts will be *Qb, Qc, Qd, etc.*, and their moments, *Qb², Qc², Qd², etc.* The condition, then, which must be satisfied for equilibrium of rotation is given by the equation

$$Pa = Q(b^2 + c^2 + d^2 + e^2 + f^2 + g^2 + h^2);$$

as before.

Hence the secondary resistance of bolt (1)

$$Qb = \frac{Pa \times b}{b^2 + c^2 + d^2 + e^2 + f^2 + g^2 + h^2},$$

Secondary resistance of bolt (2)

$$Qc = \frac{Pa \times c}{b^2 + c^2 + d^2 + e^2 + f^2 + g^2 + h^2}$$

and so forth for the result of the bolts.

Hence, substituting for *a, b, c, etc.*, their values given in the sketch, we have for the resistance of bolt (1)

$$Qb = \frac{50,000 \times 6.5 \times 14.5}{14.5^2 + 9.5^2 + 4.75^2 + 2.5^2 + 1.2^2 + 7^2 + 2^2} = \frac{50,000 \times 6.5 \times 14.5}{526} = 9,000 \text{ lb.}$$

Since the force *P* acts at considerable distance from the plane of the vertical flange there is also a turning moment about the line *KK* which is too great to be neglected. (In case the forces from the inner and outer sides of the

hub do not act in the same direction, the moments caused by their combined action should also be considered.) In this case the moment is equal to Pa' , and causes tension in the bolts in the vertical flange and shearing stresses in those in the horizontal flange.

From the formula

$$Q1b1 = \frac{Pa \times b1}{b^2 + e^2 + d^2 + e^2 + f^2 + g^2 + h^2}$$

Substituting the proper values, see Fig. 8, we have for the resistance of bolt (1)

$$Q1b1 = \frac{48,750 \times 2.5 \times 16}{16^2 + 11^2 + 6^2 + 1^2 + 13^2 + 8^2 + 3^2} = \frac{48,750 \times 2.5 \times 16}{656} = 2,970 \text{ lb.}$$

Tensile unit stress =

$$p = \frac{2970}{0.994} = 2,990 \text{ lb. per sq. in.}$$

The resultant, R , of the direct resistance p and of Ob is found graphically to be 11,000 lb. (See diagram Fig. 9). The shearing unit stress in the bolt =

$$v = \frac{11,000}{0.994} = 11,080 \text{ lb. per sq. in.}$$

Since the bolt (1) is subjected to a shearing stress as well as a tensile stress it is necessary to find the maximum combined stresses. This can readily be done by using the formulae

$$T = \frac{1}{2} p + \sqrt{v^2 + \frac{1}{4} p^2} \quad (1), \text{ and,}$$

$$S = \sqrt{v^2 + \frac{1}{4} p^2} \quad (2)$$

Where T = maximum tensile unit stress
 S = maximum shearing unit stress
 p = applied tensile unit stress
 v = applied shearing unit stress

Substituting the values already given for p and s we find:

$$T = \frac{2,990}{2} + \sqrt{(11,080)^2 + \frac{(2,990)^2}{4}} = 12,660 \text{ lb. per sq. in.}$$

$$S = \sqrt{(11,080)^2 + \frac{2,990^2}{4}} = 11,170 \text{ lb. per sq. in.}$$

Let us now investigate the nature and intensity of the stresses in one of the bolts in the horizontal flange $O-N$. The

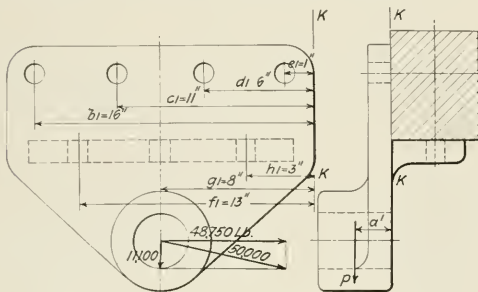

Fig. 8.

worst case is obviously that of bolt (5). Here we have—
 Secondary resistance =

$$Qf = \frac{50,000 \times 6.5 \times 12}{526} = 7,400 \text{ lb.}$$

which is in the nature of a pull.

The moments of the component of P about KK also causes a shearing stress in this bolt.

$$Qf = \frac{48,750 \times 2.5 \times 13}{656} = 2,420 \text{ lb.}$$

Shearing unit stress =

$$\frac{2,420}{0.994} = 2,430 \text{ lb. per sq. in.}$$

There is also the direct resistance p which was already found to be 7,140 lb. As this force p is inclined to the axis

of the bolt it is necessary to resolve it into its component in the direction of Qf and of its normal. These are shown in the adjacent sketch Fig. 10, where p' represents an additional pull of 1,000 lb. and p'' a shear of 6,700 lb. Then, tensile unit-stress,

$$p = \frac{7,400 + 1,000}{0.994} = 8,400 \text{ lb. per sq. in. ;}$$

shearing unit-stress =

$$v = \frac{6,700}{0.994} = 6,730 \text{ lb. per sq. in.}$$

combining this with the shearing stress of 2,430 lb. per sq. in. due to the moment Qd' , we find the combined shear to be 7,170 lb. per sq. in. The solution of the problem would be incomplete if we did not ascertain whether bolt (5) is

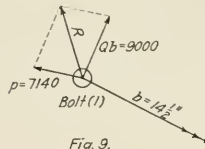

Fig. 9.

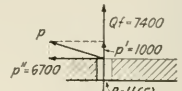

Fig. 10.

capable of withstanding the combined effect of the shearing and tensile stresses.

Substituting for p and v , in formulae (1) and (2), their values found above, we have

$$T = \frac{8,460}{2} + \sqrt{(7,170)^2 + \frac{(8,460)^2}{4}} = 12,550 \text{ lb. per sq. in.}$$

$$S = \sqrt{(7,170)^2 + \frac{(8,460)^2}{4}} = 8,320 \text{ lb. per sq. in.}$$

In the same way the stresses in the other bolts may be determined, although it is clear that these stresses can not be higher than those just found. While there are certain approximations involved in this method of calculating the stresses in bolts, the slight errors which they might cause are negligible as compared with the variations due to inaccuracies of workmanship. The stresses in bolts as determined by this method are well within the limit of accuracy required in the ordinary problems of design.

SMOKELESS FUEL FROM WOOD WASTE.—A process for making smokeless fuel from wood waste is in course of development at Nanaimo, British Columbia, according to a report from American Consul R. D. Mosher, stationed at Victoria, B. C. It is estimated that 15,000 cords of wood waste are now destroyed daily in the province. By the new process this material would make 10,000 tons of smokeless fuel. It is said that this fuel can be produced at the factory for \$2.50 a ton. The fuel is made by a progressive distillation process, carried on entirely by means of heated and cold gas, and no foreign substance enters into it.—*Weekly Telegraph*.

MAIL TO BE SENT BY AIRPLANE.—The postmaster general proposes to establish aerial transportation for letters, on one route, as soon as practicable, and has asked for bids for the construction of five airplanes for an aerial route for the delivery of first-class mail between Washington, Philadelphia, and New York, making one round trip per day. The contract will be awarded to the bidder whose airplanes have stood satisfactory service test in the war and navy departments. It is the purpose of the postoffice department to make this a permanent service. An appropriation of \$100,000 is available. The intention is, as soon as the authority of Congress is received, to establish a through aerial route to Philadelphia and New York, carrying 300 pounds of first-class mail, for the transmission of which a special postage rate will be charged, not exceeding 25 cents an ounce.



SHOP PRACTICE



AIR COMPRESSOR TABLE

BY J. H. HAHN

A particularly substantial and useful table for the support of all sizes of air compressors while being repaired, has been designed by F. P. Brotherton and the writer and tried out with good results in the Norfolk & Western shops at Bluefield, W. Va.

This device is made up, as shown in the illustrations, of a hinged table mounted on the upper end of a piston rod, the piston and cylinder of which are beneath the floor. A

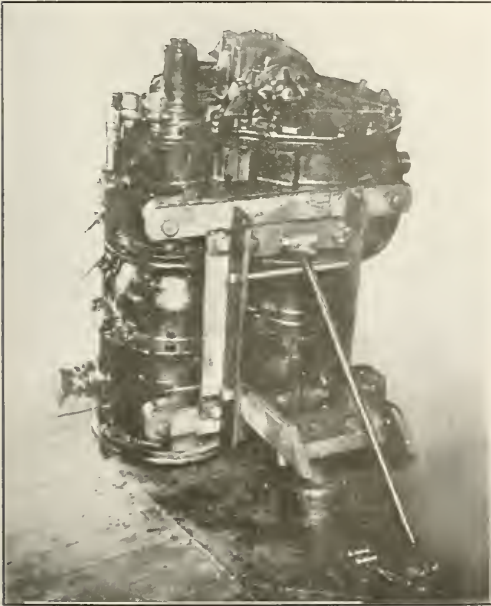

Fig. 1—Air Compressor Bolted to the Table and Ready to be Lifted

movable arm, connected at one end to the floor and at the other end to the free side of the table, causes it to change from a vertical to a horizontal position when the piston rises.

In operation the compressor is up-ended and bolted to the table as shown in Fig. 1, the air being released from the cylinder. When it is desired to raise the compressor, the air is turned on and the piston begins to rise. This lifts the lower end of the table, but the upper end is restrained by the movable arm so that it gradually tips until with the piston in its extreme upper position, the table and compressor rest horizontally as shown in Fig. 3. The table is then locked by means of a long pin extending through the frame at the

top of the plunger. The arm is removed so it will be out of the way of the repair man. Before going ahead with the repair work, a sheet iron sleeve is put around the piston rod,

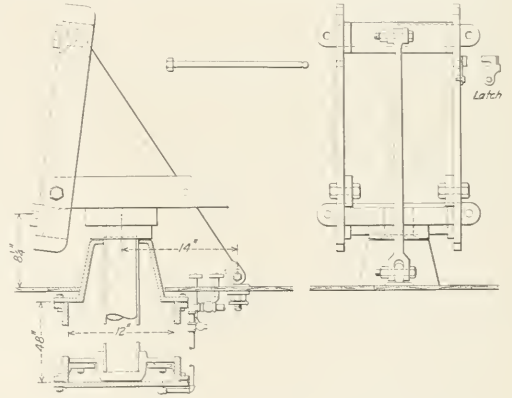

Fig. 2—Air Compressor Table Assembled

and the cylinder air pressure released. The sleeve then holds the pump at the required height and prevents waste

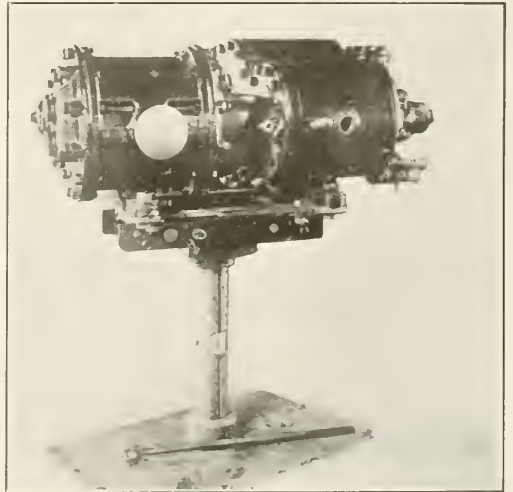

Fig. 3—Air Compressor Lifted and Ready to be Overhauled

due to air leakage by the cylinder packing leather. If more convenient for the workman, sleeves of different lengths may

be provided, which with the arm attached will hold the compressor at any required angle desired. By providing auxiliary brackets which may be applied to the table, it may be used for making repairs to all sizes of compressors.

Details of the arrangement, shown in Fig. 4, give the dimensions used in this particular case, but they are subject to change as occasion may require. The piston rod is turned to a loose fit in the cylinder sleeve and has a shoulder on the upper end. The yoke or part that fits on the upper end of the rod is forged in one piece and this insures the necessary strength and stiffness. The hinged table is built up of 2½-in. by ¾-in. stock, strongly braced and riveted together. The auxiliary bracket shown in the lower left corner of Fig. 4 is of the right dimensions to support a 10½-in. Westinghouse cross compound compressor, but it may be made to suit any size or type of compressor. The cylinder used was an engine truck pit jack cylinder 12 in. in diameter, having a 48-in. stroke. But here again the selection is an arbitrary matter and any available cylinder large enough to handle the work may be used.

Many air brake foremen have felt the need of a substantial and durable compressor repair table and these qualities are possessed by the one just described. In addition, it does away with the necessity for air hoists, runways, chain falls or blocking. There are no legs to get in the way of the repair man and the compressor may be adjusted to any height or angle required. Also on account of the whole arrangement

AIR COMPRESSOR OILING STEP

On many locomotives the running board comes either on a level with or above the air compressor, and for proper inspection and oiling it is necessary to stoop down and reach

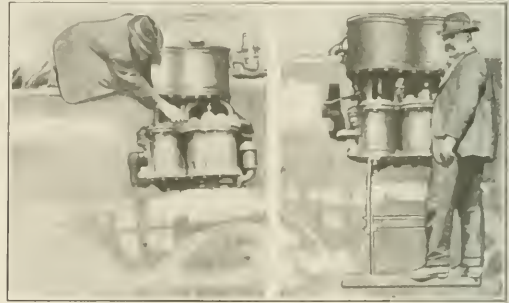

The Danger in Oiling a Pump by the Old Method is Avoided by a Safety Step

around the pump as shown in the left of the illustration. This is not only an awkward position to be in, but dangerous as well, due to the chance of slipping. Greasy hands, icy

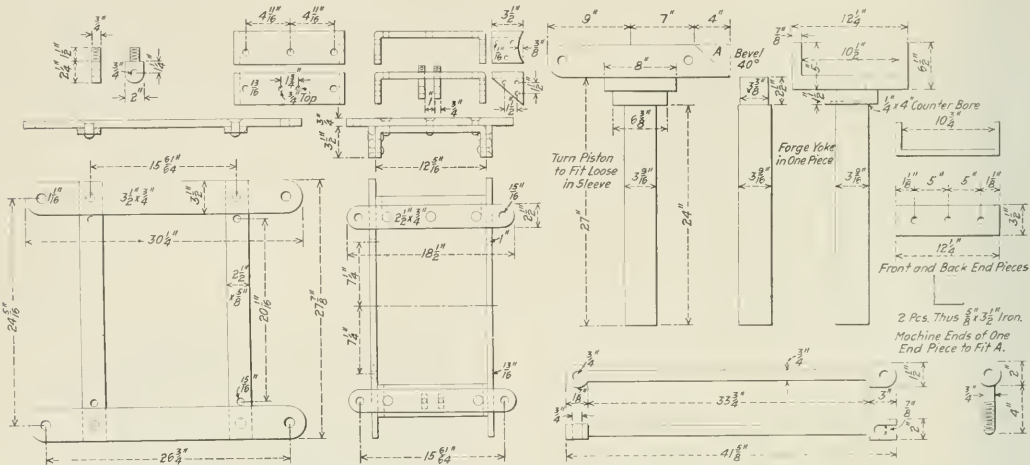

Fig. 4—Details of Universal Air Compressor Table

being rigid, it is easy to tighten cap screws, air cages, piston rod nuts, etc. All of these advantages and good features combine to make a repair table which has given good satisfaction at Bluefield shops and in fact, actually increased the output or number of compressors which are repaired per month.

handholds, or a sudden bump may result in a serious, or perhaps fatal fall.

The safety step shown in the right of the illustration was devised by S. M. Dickerson, an engineman on the Missouri, Kansas & Texas, at Ft. Worth, Texas, and it has been used successfully on a number of locomotives belonging to that road.

The step shown is of a hinge type and may be folded up under the compressor when not in use. The sides are made of ½-in. by 2-in. wrought iron, securely bolted to the bottom of the pump. The rounds are of ⅝-in. round iron with the ends turned down to ½ in. where they go through the side frames. They are left long enough so that they may be headed over.

The estimated cost of manufacture of this safety step is \$6.50, which figure could be materially reduced if large numbers of steps were made.

EQUIPMENT NECESSARY FOR ENGINEERING REGIMENTS.—The scope of the work of equipping the regiments of railway engineers now in France is indicated by the cost of materials ordered up to date, which approximates \$70,000,000. The equipment so far ordered includes several hundred locomotives, more than 100,000 tons of rails, more than 3,000 complete turnouts, 500,000 ties, 12,000 freight cars, 600 ballast cars and 600 miles of telephone wire and apparatus, as well as large quantities of construction and repair equipment.

BOILER SCALE AND WATER TREATMENT*

Mechanical and Chemical Methods of Preventing
Scale Formation and Corrosion from Bad Water

BY GEORGE AUSTIN

General Inspector Boilers, Atchison, Topeka & Santa Fe

FORMATION of mud or salts or both on the water side of the tube sheet of a locomotive boiler covering the copper flue ferrules, a film of slime between the firebox plates and the water, or water in the boiler heavily charged with suspended matter, or scale formation, causes overheating and leaking. It may as well be said at the start that overheating is the principal agent, and other causes are accessory. The first indications of flues and some times other parts being near the leaking point are small light colored beads of sodium salts, mixed with other solids, adhering to the edge of the flue beads. Although flues are tight in the holes, there are small crevices through which the slime works its way and the moisture quickly evaporates on the hot plate, leaving a dry hard deposit, that temporarily plugs up the hole it leaked from. In most cases

clean when they leave the terminal, perhaps freer from mud and scale than boilers on other districts, which give much better performance. The salts from the water being evaporated, precipitate at the points at which evaporation is accomplished. This being nearest to the heating surface, a film of slime grows between the plates and the water causing overheating. That may not be just the right explanation, but, it is not far from it. This slime making water as well as the scale forming water, just spoken of, will always give trouble as long as we let it get into the boilers. Neither case is subject to mechanical improvement, except, so far as adequate facilities may be provided for washing boilers and changing water.

The fillet of scale which forms over the copper ferrule, regardless of its composition, reduces the power of the copper ferrule as a conductor to keep the end of the flue from getting hotter than the flue sheet. It has been suggested that a wider ferrule than is commonly used will require heavier incrustation to impair its efficiency as a conductor and widen the interval between leaks, which reasoning is very plausible.

Scale formation in arch tubes and firebox sheets is indicated first by a sand paper roughness of the parts which are becoming affected, and later by clinker, or as it is sometimes called honeycomb clinging to it. It actually seems as if it was trying to defend itself from injury by establishing a non-conductor of honeycomb on one side to offset the scale formation on the other. The smooth, slightly rounded flatter or bobbing tool in a No. 3 air hammer is effective in most cases in removing this scale. By working on the fire side the jar seems to cause it to flake off. Boilers should be warm when such work is done. There is little danger of cracking the plate by using the methods here mentioned to remove the scale and there is great danger of developing cracks if it is not removed. On some divisions we rattle our fireboxes nearly every month, which is our term for the operation.

We must keep fireboxes clean if we are to get service from them. Clean fireboxes and boilers cut down repairs. Some roads have adopted the system of giving the flues a periodical expanding and claim good results; although we wait for the leaking indications, the same thing is accomplished. The expanding removes the scale and maintains the copper ferrule as a conductor.

SIMMERING LEAKS

By simmering leaks, is meant small leaks in fireboxes that leak continually, but not enough to form a stream and run down the plate and give trouble. These should not be permitted, especially where the water in the boiler is heavily charged with suspended solids. These small simmering leaks are just big enough to let the water through and fine enough to keep back the mud and build up a mud fillet around the flue or staybolt. Overheating is frequently so severe that the flues and staybolts affected become loose in the holes. Many engine failures are due to permitting simmering leaks, especially among the flues. The above class of failure most frequently occurs during seasons when the water is muddy.

Flue performance may be accepted as a barometer indicating firebox performance. If you have no flue troubles,

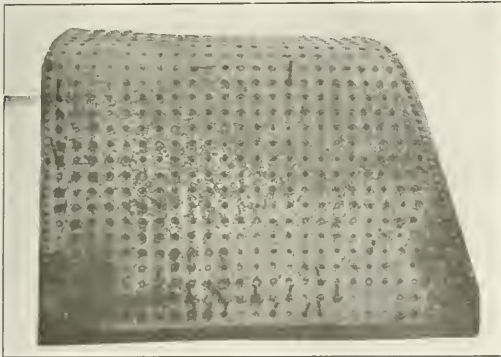

Side Sheet Corroded by Bad Water

the engine will make another trip; in some districts it will not do so, without leaking pretty badly or failing. A knowledge of local conditions should and usually does govern the kind of work, if any, to be done on flues, showing those pre-leaking indications. The remedy, of course, is to remove the scale which has formed on the water side. To wait until a leak starts is to wait until some damage is done. Leaks caused by overheating damage the parts affected, nor can repairs be made without further injury, that is, nearly every time flues are worked, their life is shortened. Therefore, on account of overheating causing the necessity for repairs, our energies should be directed to keeping the boiler clean and preventing overheating.

Feed waters heavily charged with incrusting solids will form scale among the flues and staybolts where we cannot get at it to wash it off. We couldn't wash it off if we did get at it; it must be knocked off. Scale forms mostly while the engine is working and at those parts which attain the highest temperatures, probably, because they evaporate more water and a larger quantity of solids are precipitated.

In the case of waters heavily charged with alkalis, the injunction to keep the boilers clean will create a strong sense of the futility of such a remark. Those boilers are

*From a paper presented before the Western Railway Club.

you have no other boiler trouble. If you have small flue mileage, you have small firebox mileage. If you help the flues, you help the firebox.

KEEPING BOILERS CLEAN

The wash-out appliances including scrapers and search lights used on the Santa Fe were illustrated in the 1915 proceedings of the Master Mechanics Association on pages 398 and 399. (See also Daily Railway Age Gazette, June 12, 1915, page 1296.) We use all the good ideas we can get both as to systems and appliances, which fit our conditions, including hot water boiler washing plants. We wash out locomotive boilers as often as any large railroad in this country, and everything practicable is done to keep boilers clean. Boiler cleaning is a roundhouse job. Dirty, poorly cared for, boilers coming in for general repairs, generally need considerable firebox and boiler repairs, indicating poor looking after in the roundhouse.

TREATING FEED WATER

So far we have dealt with mechanical means of keeping boilers clean, which in certain territories will be found efficient, that is, where the average hardness of the feed water does not exceed six grains per gallon, or road service is not too severe. Excepting perhaps Lake Michigan water I do not know of any water on the Santa Fe, so low in incrusting matter unless accompanied with foaming solids.

Any water treatment that will dissipate the fillets of scale from the flue ferrules or other parts to prevent its formation, is far and away ahead of any mechanical treatment, for the reason that chemical action anticipates and prevents possible damage and affects all parts, while mechanical treatment is deferred and local only, and follows possible damage and fuel losses. It is therefore, evident that we may look for the greatest improvement through water purification or treatment, either by treating the water before it is delivered to the locomotive or in the tank and boiler. If the volume of business on a district is small or the water is not bad enough to justify the expense of water treating plants, during these times it may be very profitable to treat the water in the engine tank. Increases in the demands for power, and cost of labor and material and the greater value of the locomotive, have changed and are still changing values; what would have been considered extravagance yesterday may be good business today. The Santa Fe has road side water treating plants, 125 of them; they use anti-foaming boiler compound, and also, a compound to prevent incrustation and foaming as well. We also use soda ash applied to the locomotive tanks. All water treatment is under the direction of the chief chemist. On some districts the water treatment is supplemented to a limited extent by mechanical means, that is, it is found profitable to a limited extent on some districts to use both chemical and mechanical means. For example, if the staybolts show leakage and inspection shows scale forming, a light pneumatic hammer and bobbing tool are used on bolts and plates in the leaking zone and scale knocked or jarred off. When water treatment creates too much foaming, we may obtain better results by allowing a little scale forming, which may be taken care of by mechanical means. Water treatment may be brought to a point where it is better to allow a little scale than have excessive foaming.

PITTING FLUES AND OTHER CORROSION

The Santa Fe like other roads in bad water districts has to contend with pitting and corrosion. While corrosion of firebox plates has resulted in short life of many fireboxes, flue pitting causes frequent failures and is most annoying on that account. Just what causes pitting and corrosion is not altogether clear. One may advance a theory for a given case and be forced to admit that it does not fit some other. The

electrolytic theory seems to be most reasonable when applied to flue pitting, which assumes that there is a positive and negative pole, with an electrolyte or carrier. In proportion as the water increases its soluble salts the efficiency of the carrier or electrolyte increases, therefore, anything tending to diminish the power of either pole, or the carrier between them, will weaken the corrosive action.

The company which furnishes the treatment we use to overcome foaming, claims that it prevents foaming by changing the nature of the soluble salts, and that this change also overcomes the tendency to cause corrosion, by making the salts a less active electrolyte. This claim seems to be borne out by the fact that we have had more trouble from corrosion since



Effect of Corrosion Around Staybolts

adopting superheater engines, which require a smaller quantity of treatment to overcome foaming, or that part of foaming which formerly annoyed the engineer. This is on account of the tendency of the superheater to dry up the water that is carried over. We have had cases where by washing and changing the water frequently engineers have been able to run in bad foaming districts without the use of this treatment. While they considered this a saving to the company, it developed that there was damage from corrosion. We are now using this treatment in sufficient quantities to overcome the foaming tendencies of the water, whether the engineers consider it necessary or not, and find that our trouble from corrosion is diminishing.

It has been observed that passenger engines using anti-foaming compound, pitted more than freight engines on the same district; that superheater passenger engines, in the same service pitted more than saturated engines, and it has been found that when a small quantity of boiler compound is applied when the boiler is washed, or has water changed, and also applied in the engine tanks wherever water is taken, thus keeping the water in the boiler slightly treated at all times, flue pitting has been reduced. We have not had this continuous treatment in operation long enough to know just how much it is helping us, but reports received from points where the system has been carried out, are all favorable.

Referring to corrosion of firebox sheets, two illustrations are shown of fireboxes that have been removed on account of internal corrosion. These pictures were taken about five

years ago and were not uncommon cases at that time. These seem to be plain cases of allowing scale to form at the junction of the stays with the firebox sheets; just a dirty boiler, that's all. If we feel that it is not practical to try and improve these conditions, the conditions have us beaten. If on the other hand, we call to our assistance the chemist and help him to help us, we will without a doubt beat the condition, which was done in these cases.

BLOWING OFF HELPS BOILER CONDITIONS

Any method of water treatment is benefited by the judicious use of the blow off. Short frequent openings, a short time after the locomotive comes to a stop, or just after starting, give the best results. Starting with the beginning of the trip frequently blowing a small quantity of water out at convenient times, when it can be just as well done as not, will keep down the concentration of foaming solids and allow greater mileage between washouts. There are occasionally times when it is necessary to practically change the water in the boiler, but these occasions are usually due to failure to anticipate that condition, or in other words, the blow off was not used soon enough to prevent the water becoming heavily charged with foaming matter. When the water in a boiler becomes so bad as to practically need changing and the engineer wants to give it a good blowing out, do not fill up and then blow out; blow out all that can safely be done first, and then regain the usual supply slowly; if necessary, repeat the operation. Filling up before the blow off is opened simply dilutes the foul water we want to get rid of and wastes the fresh water.

With muddy or roily water not accompanied by foaming, the boiler is greatly benefited by frequent short blow offs, and the possibilities of mud burning and flue and staybolt

leakage, cracking and patching on the right than on the left sheet. While it must be admitted, there is a point at which blowing out begins to be a waste of effort; water and fuel, and different districts require different treatment, a generally good rule is to use the blow off freely in all districts where bad water prevails. This brings the engine to the terminal in the best possible condition to be turned. If boiler compound is used, the water should be kept saturated with it, thus reducing pitting and foaming and the liability of running short of water on account of working it out through the cylinders and stack. Foaming will lose more water than need be blown out in a trip to prevent foaming.

Water treatment should be installed wherever practical. Stopping leaks is a poor substitute. The cost of water treatment can be determined, but who can say what its absence may cost in the way of deterioration of boilers and failures and delays of power, incident to poor water conditions? If it seems too expensive to install road side treatment, try treating in the boiler or tender. Encourage the chemists to experiment, stimulate them to develop treatment suited to the conditions. Chemical experiments promise results along the lines of conserving steam boilers which can be expected from no other source.

• SPRING BANDING MACHINE

BY J. H. CHANCY

The spring shop of the Georgia Railroad at Augusta, Ga. is equipped with a spring banding machine which has given satisfactory service since its installation and may offer a suggestion to spring shop foremen who are in need of such a device. The illustration shows in plan and elevation

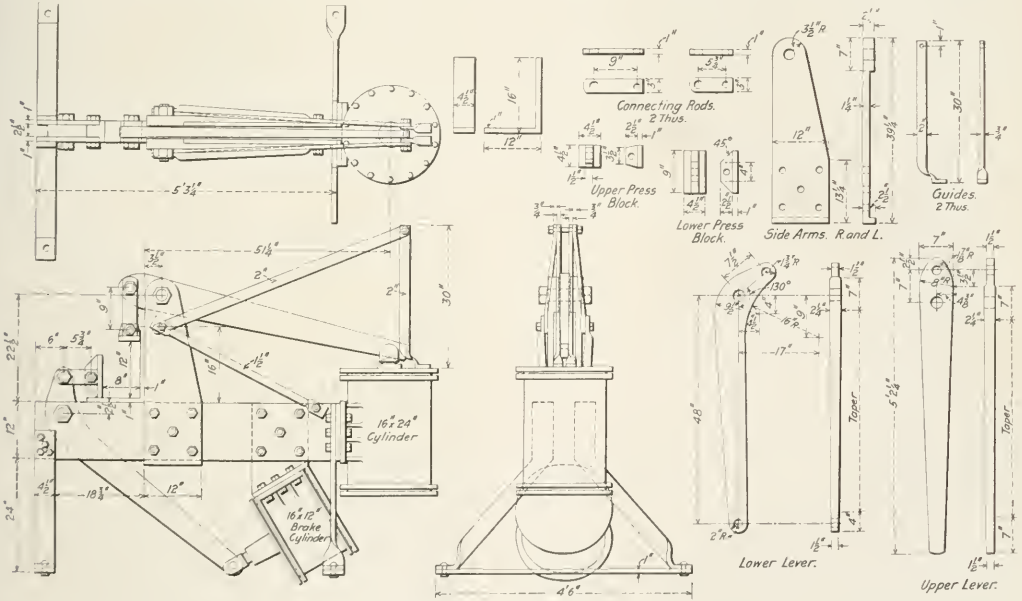

A Machine for Applying Bands to Locomotive Springs

leakage are reduced. The water in the boiler is free from suspended matter, and better circulation and steaming is assured. Blowing out from both sides, should be the rule. When, as is often the case, more blowing is done from the left than the right side, the effects are shown by more staybolt

how the spring bander is constructed. The machine was made from scrap and second hand material found around the shop and the total cost was \$216 including labor and what little material had to be obtained from the storeroom.

As shown, the two cylinders are firmly bolted to a rigid

frame which is supported by braces from the floor. The fulcrum pins are large and case-hardened to give greater wearing qualities. The ratio of the long to the short lever arm is such that with 90 lb. air pressure in the cylinders, a powerful leverage is secured.

The operation of the machine, as will be readily understood from the drawing, consists in placing the spring sheaves encircled by a red hot spring band, between the jaws and turning on the air pressure to the vertical cylinder. This operates through the fulcrum and lever to compress the sheaves and when air pressure is applied to the other cylinder, the spring band is compressed and upset, so that when it cools, the band contracts and holds the sheaves firmly in place.

On account of the big leverage available in this machine, it is also adaptable to doing many other jobs which occur in blacksmith shop practice.

GAGES FOR DRIVING BOX WORK

BY J. H. HAHN

In a locomotive repair shop where large numbers of new driving boxes are laid out at a time preparatory to being machined, the combination square and centering gage shown in the illustration will be found a convenient tool. It is made of $\frac{1}{4}$ -in. by 2-in. stock, cut and bent to the shape shown. The 6-in. arm is at right angles to the long arm and the extension that bears on the shoe and wedge face of the driving box has been lengthened so as to maintain the gage at right angles with the center line of the box. With the gage in place a line scribed on the left side of the 6-in. arm will reproduce the shoe and wedge face on the face of the box. It is then easy to lay out the driving box for slotting, or to center a bar for the boring out of the crown bars.

A 2-ft. square and a centering gage would ordinarily be

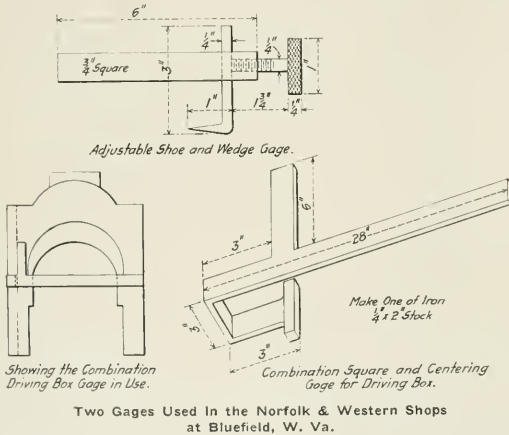

necessary in laying out a driving box and the combination of these two tools in one eliminates many false moves and results in a considerable saving of time. The tool has proved its value in the Norfolk & Western shops at Bluefield, W. Va., where it was first introduced.

ADJUSTABLE SHOE AND WEDGE GAGE

The adjustable shoe and wedge gage illustrated, while comparatively simple in construction, has been a good time saver in laying out driving box shoes and wedges preparatory

to lining the engine. Very often one engine frame will be a little ahead of the other, due to contraction of frame welds or other causes, and in that case it often becomes necessary to machine the shoes and wedges either over or under the standard thickness (1 in.). The adjustable gage then comes in very handy for checking up the work and proving that the shoe or wedge has been accurately planed down to the marks.

As illustrated, the gage is made of a piece of $\frac{3}{4}$ -in. square stock, 6 in. long, drilled and tapped at one end to take a $\frac{1}{4}$ -in. knurled thumb screw. This thumb screw holds the scriber which is bent, hardened and ground to a point at one end and is adjustable in or out.

PRINCIPLES OF THE GENERATION AND APPLICATION OF HEAT IN STEEL TREATING*

BY A. F. MAC FARLAND†

The primary considerations in the heat treatment of steel are the generation of heat and its subsequent application to the metal undergoing treatment. Discussion of such a large subject is something of a problem because so many important points have to be considered and it has been deemed expedient to deal only with the fundamental principles involved, as exemplified in some of the methods in use at the present time.

Ideal heat treating conditions would be realized if we were able to transmit simultaneously to each molecule of steel a certain given amount of heat in a certain given time. This, however, in practice is not attainable for reasons that appear obvious upon consideration of the inherent properties of steel, particularly its specific conductivity. As an illustration of the ideal situation, assuming that we have a solid sphere of steel suspended by some means in a hollow spherical muffle which is heated uniformly all over, the ideal is approached, obviously, as the size of the steel sphere decreases. In an effort to approach as nearly as possible to the ideal in heat treating, fuel and furnace engineers have brought out a vast number of burners and furnaces of various types and designs, many of which are on the market at the present time.

In industrial heating there is no general agreement as to what to use as a heating element and what sort of furnace to use it in. No single type of furnace, fuel or system is applicable to all problems. Quality of product and cost of manufacture are the basis on which the selection of the method of heat treatment should be determined. Obviously, it would not be feasible from a practical standpoint to treat 18-lb. high explosive shells in small electric furnaces, nor would it be advisable to treat small steel balls in a gas furnace with a 6-ft. by 4-ft. hearth. Each class of work calls for its own special arrangement for heat treating, hence we have such a great variety in furnace design and methods of heat generation.

A table of fuels commonly used for heat treating, with their relative heating values and costs, is given below. Electricity has been classed here as a fuel, inasmuch as this paper deals with it primarily as a means of heat generation. The figures for fuel oil, city gas and electricity are based on recent prices; however, it is not desired that any of these computations be taken authoritatively, for in these days of fluctuating prices the computations of today are entirely upset by tomorrow's quotations.

A great many mistakes have been made in selecting a fuel from a table of this nature. It is true that these figures

*Abstract of a paper read before the Chicago Section of the Steel Treating Research Society, January 14, 1918, by A. F. MacFarland, metallurgist, U. S. Ball Bearing Manufacturing Company.

†Metallurgist, United States Ball Bearing Manufacturing Company.

represent accurately the calorific value of fuels, determined by careful experiment in the laboratory. However, the actual calorific power obtained in practice depends entirely upon the method of burning the fuel. For example, the old style oil burner of the forge shop will not give the calorific value from one gallon of oil that the recently perfected

comparatively recent years that furnace men have been awakened to the crying need of better furnaces. With this awakening has come the electric furnace, new systems for burning oil, gas and coal and the basing of recent furnace design on sound scientific principles.

Electric furnaces used in commercial heat treating may be roughly classed under two heads:

1. Wire-wound furnaces, where the resistance material consists of wire, usually composed of an alloy of nickel and chromium, and useful for temperatures up to about 1,800 deg. F. These furnaces range in size from small laboratory furnaces to muffle furnaces with chamber dimensions of 24 in. by 24 in. by 48 in.

2. Carbon resistance furnaces where the resistance material is carbon. Small furnaces of this type may be used for relatively high temperatures and are suitable for treating high speed steel and even for melting a quantity of brass. The construction of wire-wound furnaces, is very simple if the necessary materials are at hand, and they afford the nearest approach to ideal heating conditions. This is especially true where the work is suspended, and receives heat from all sides, both by radiation and by conduction through the atmosphere.

Gas and oil furnaces are, perhaps, the most widely used for commercial heat treating, and on account of lack of time only a few of the many possible designs will be commented upon.

In the case of the simple underfired furnace which is being used at the present time for a large number of heat-treating operations, the combustion takes place below the hearth and the hot gases pass around the sides of the hearth into the heating chamber. Obviously, the edges of the hearth will heat first, and any stock placed in the furnace near the edge of the hearth will heat locally in the place which is nearest the edge. This can be overcome to some extent by building up the sides of the hearth. This arrangement also stops any overloading at the sides of the furnace and tends to prevent cutting action of the gases near the hearth line. There is no need to build these sides beyond a certain height, for once properly guided, the hot gases by nature will continue in an upward direction to the roof of the furnace. The location of the vents in a furnace is important and they should not be put in the roof, where they will allow the hot gases to escape and be wasted. Certain efficient types of furnaces are designed to use the exhaust gases in preheating the air before it goes to the combustion chamber.

In connection with furnace design, mention of furnace capacity and overloading is opportune. In no case should a furnace be loaded full with carbonizing boxes, for instance, that rest directly on the hearth and are closely packed together. It is necessary that space be left for the free circulation of the hot gases or the charge will not be uniformly heated.

Over-fired furnaces have many adherents, but as a rule they are adaptable only to low charges. When the charges are high there is a tendency to overheat the top, and this feature, combined with a cold hearth, make uniform heating practically impossible. The advantage of this type of furnace is the ease with which the material to be heated may be handled.

It is unnecessary to go into the design of coal-fired furnaces because of the fact that they are being rapidly replaced by equipment using oil or gas. However, powdered coal could probably be used to distinct advantage in some heat-treating operations, and the field for the use of this fuel is being rapidly extended, due to its decreasing cost.

In regard to forging furnaces, it seems to be a prevalent idea that any manner of heating device will suffice to bring steel to the proper temperature for forging, but on the contrary too much care cannot be taken in the furnace design. "Dipping" heats as well as "soaking" heats are equally to be

THE RELATIVE HEATING VALUES, COSTS AND BUYING POWER OF ONE CENT IN B.T.U. FOR FUELS USED IN HEAT TREATING, INCLUDING ELECTRICITY.

	Price basis	B.t.u. basis	Number of B.t.u. for one cent
Electricity	.01 per kw. hr.	3,412	3,412
Gas—			
City gas	.75 per 1,000 cu. ft.	660	8,000
Natural gas	.50 per 1,000 cu. ft.	950	19,000
Producer gas	.10 per 1,000 cu. ft.	145	14,500
Oil—			
Crude	.075 per gal.	146,000	19,466
Kerosene	.140 per gal.	132,000	9,420
Coal—			
Bituminous	9.50 per ton	14,000	20,473

vaporizing system for burning oil will give. Oil bills have been cut in half by replacing the old style burners with this improved system.

The means used for the generation of heat also bears an important relation to the quality of the product. A fuel which carries a considerable percentage of sulphur has a deleterious effect on steel when the products of combustion come in contact with the metal. Oxidizing atmospheres in the furnace cause excessive scaling and sometimes troublesome decarburization of steel surfaces. The ease with which furnace atmospheres are able to be maintained depends largely upon the flexibility of the medium of heat generation. By flexibility is meant the ease with which the fuel lends itself to producing either oxidizing or reducing atmospheres in the furnace. Gas and oil are more easily controlled in this respect than coal or coke, depending somewhat on the facilities for burning them, while electricity is an ideal heating medium for producing neutral atmospheres. In hardening a number of small parts a short time ago in an electric furnace and quenching them from 1,500 deg. F., not one showed the least sign of scale or oxidation. An investigation of the matter showed that a new piece of insulating brick placed in the furnace was responsible for the phenomenon as it contained a substance which produced a strongly reducing atmosphere in the furnace. This phenomenon should prove of interest to a manufacturer who is treating parts where even the thinnest scale is undesirable.

The cheapest fuel, on a strictly B.t.u. or calorific basis, is not often the cheapest fuel for heat treating steel, when all the factors which have a distinct influence on the subject are taken into consideration. There is always a right fuel for the particular heat treating operation at hand, and each problem should be thoroughly studied and understood if the best solution is to be had. In heat generation and application, the human element plays a very important part. The manufacturer who invests in expensive furnaces and fuel equipment makes a grave mistake if he fails at the same time to invest in a suitable amount of brains to operate this equipment for him efficiently. Fool-proof heat-treating equipment is still a thing of the future, although considerable progress along the lines of automatic temperature control has been made, resulting in various appliances which tend to minimize the difficulties encountered, especially on very large installations, where uniformity is as important as the enormous production.

Furnace builders up to the past few years, with a few possible exceptions, seem to have been in a dormant state. While pyrometry, metallography and other related branches of steel treatment were making rapid progress, it is not until

avoided, and the furnaces must be designed to give a uniform heat throughout the stock.

In conclusion it is perhaps wise to re-emphasize the importance of heat treatment of steel and to urge a continual study of the subject.

RAILWAY SHOP FANS AND BLOWERS

BY J. H. WICKMAN

The increasing use of blower and suction fans for different classes of work around railway repair shops, makes it imperative that there should be a better understanding of the requirements for a successful blower installation. Too often, although the purchaser knows exactly what work he wants the blower to do, he has not the engineering knowledge necessary to figure out what size of machine will be required to do it and how much power it will take. In this case the specifications are usually left to the manufacturer, who guarantees to supply a certain amount of air at a specified pressure, and is not so much interested in the efficiency of the installation as a whole.

There are a number of items to consider before ordering a new blower, and, as stated before, it is usually better, on account of a more intimate knowledge of what is needed for the purchaser to solve his own problem. The purchaser should consider in detail the requirements of the service the fan is to perform, and in making his order be able to specify the size of fan, rating of the motor, the amount of air pressure and the volume required, the speed, pulley sizes, etc.

As to determining just what the specifications shall be in a particular case, undoubtedly the best method is to study an existing installation with similar characteristics. As an example, suppose a new blower installation is to be put in for the purpose of conveying shavings away from the mill room machinery. What size of motor, fan, pulleys, etc., will be required? What is the requisite speed and air pressure? A careful study and possibly a test of a blower already in operation under similar conditions and working satisfactorily will give the data on which to base specifications. Speeds may be taken by speed indicators or revolution counters, and the pulley diameters may be measured. Air pressures may be taken by means of the familiar U tube, and power intake may be measured by electric meters. In case the existing installation was not entirely satisfactory and did not produce enough pressure to carry off the shavings and refuse, it would be advisable to speed it up and take data when it was operating satisfactorily. This can always be done by changing the size of pulleys for a short period of time while taking the readings.

The air pressure will be found to vary as the square of the velocity; that is, if the pressure is to be doubled, the velocity must be increased four times. In order to illustrate, consider the following simple problem: If a fan produces one ounce air pressure at 2,800 r.p.m., what pressure will be obtained by speeding up the blower to 4,000 r.p.m.? When stated in the form of a proportion the rule set forth becomes:

$$1 : X :: 2,800^2 : 4,000^2$$

$$X = \frac{4,000^2}{2,800^2} = \frac{100}{49}$$

X = 2.04 ounces of air pressure at a speed of 4,000 r.p.m.

In regard to the power required to drive the fan or blower when speeded up, it will be found to vary as the cube of the velocity—that is, if the velocity is doubled the power required will be increased eight times. This rule may be illustrated by the following problem: If a blower revolving at 2,800 r.p.m. requires 35 hp. to drive it, how much would be required

at 4,000 r.p.m. Let X equal the required power and express the above rule in the form of a proportion:

$$35 : X :: 2,800^3 : 4,000^3$$

$$X = 35 \times \frac{4,000^3}{2,800^3}$$

$$= \frac{35 \times 1,000}{1} = 35$$

$$= 102 \text{ hp.}$$

In conclusion it may be stated that while the above method of figuring on a blower installation may not be strictly scientific and according to the best engineering standards, it will give quick and reasonably accurate results.

POLISHING ASH PANS IN FRANCE

FROM A LIEUTENANT OF THE SHOP REGIMENTS

I have just been reading the August number of the *Railway Mechanical Engineer* and have showed it to the French railroad officers. They were particularly interested, but their point of view is so different from ours that it is almost impossible to make any comparisons of work or methods in the shop. While they do waste a lot of energy in polishing up the ashpan and putting "inlaid patching" on the bumper beam, they finally end up by turning out a locomotive that is right and will stay right for a long time.

The French workmen start work at 6:00 a. m. or rather about 6:15 and do about three hours' work between 6 and 12. At 12 they start to go home, or rather they start to go home at 11:45, and do not return until 2:00 p. m. Work starts at 2:10 p. m. and continues until about 7 p. m. Altogether about five hours of work in a really good shop is all they do in the entire day, but they do it right. The ashpan is just as carefully fitted up as the valves.

At first I could not understand how they set the valves, but finally discovered that the valve motion was so carefully fitted up in the machine shop that it was not necessary to make adjustments after it was applied to the locomotive.

The adjustable type of wedge which we use in America made quite a hit with the French officers, but many of the large engines here do not have wedges—the box is pretty tight fit in the jaw and they claim there is only one millimetre wear in the jaw each year. It sounds a bit fishy to me, but I am no longer surprised at anything.

These locomotives are in splendid condition—they run as smooth as an eight-cylinder automobile—not a pound anywhere.

The title "engineer" over here covers a multitude of sins—an engineer wanders about and looks wise, if possible—so far as I can discover, he never by any chance does any work except to discuss technical subjects from the purely scientific standpoint without arriving at any conclusion. Perhaps I shall revise all my opinions next week, so I'll go no farther with them now.

I can now speak very much better French than when I first arrived and hope to be proficient in a couple of months. The French people are very much pleased because our boys all started in at once to learn French. The British make very little effort in that direction, and the French have noticed it.

From all indications the railroad shops are to all effects and purposes strongly unionized. I am amazed that the French army, which is a very efficient machine, has not taken over the railroads also. The French workmen go at exactly the same pace as in peace time and they spend just as much time in polishing the ashpan and putting inlaid patches on the bumper beam as they ever did. In this little shop there is enough copper and brass to supply a whole railroad.

SOME INTERESTING BOILER SHOP EQUIPMENT

BY F. W. SEELERT

The machines illustrated in this article were built several years ago at the Shoreham shops of the Soo Line and have proved to be entirely practicable and economical, both in operation and in upkeep. The hydraulic superheater flue tester, Figs. 1, 2 and 3, was designed by

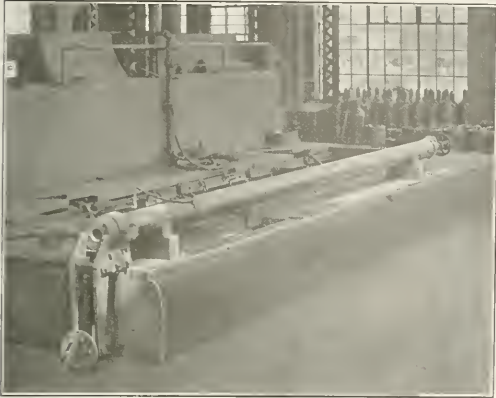

Fig. 1—Hydraulic Superheater Flue Tester

the boiler shop foreman, Martin Sobraske, who has a patent pending on it. The outstanding feature of this machine is the testing of flues under actual working conditions by hav-

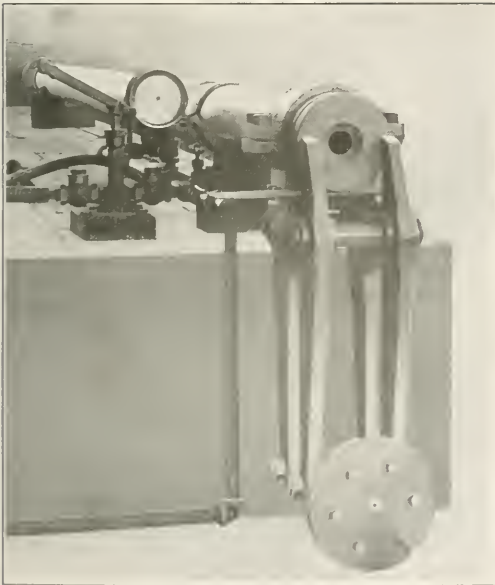

Fig. 2—Showing Front End of Flue Tester

ing the pressure applied from the outside. Fig. 1 shows the general appearance of the tester, which is mounted on the concrete retaining wall of the flue ratter. The front end

from which the flues are entered is shown more in detail in Fig. 2, and Fig. 3 shows the rear or piston end of the machine with the adjusting screw and wheel.

The cylinder is a 7-in. double extra heavy pipe 23 ft. 6 in. long, the inside of which is bored out to 7¼ in. diameter for a length of about 12 ft. from the back end toward the center, in order to provide a good finished surface for the hydraulic leather packed piston. The front end of the cylinder is closed by a removable cap, which is tightened by a substantial clamp arrangement operated by a screw and hand-wheel. The details of this design are shown in Fig. 2. The piston in the back end of the cylinder can be fitted to extension pipes of suitable lengths, so as to take care of flues from 12 ft. to 23 ft. in length. The ends of the flue and also the front end of the cylinder are sealed watertight by means of hard rubber rings inserted in the cylinder cap and the piston respectively.

In operating the machine a flue is placed in the cylinder and properly tightened up, the space around it being filled with water by simply opening the cock shown on top of the cylinder in Fig. 2. After the cylinder is filled, the pressure is raised by the little hand pump shown at the left in Fig. 2. A few strokes are sufficient to give a pressure of 450 lb. or 500 lb. and the flues are then inspected through the opening in the front cylinder cap. An electric light bulb,

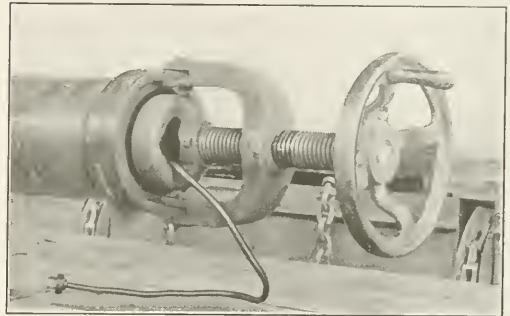

Fig. 3—Back End of Flue Tester

fastened in a similar opening in the piston on the other end of the flue, provides proper illumination for the inspection and any leak will be readily detected. This machine gives an accurate test for flue defects due to unsound welds, pit marks, etc., and it paid for itself in a short time. A set of flues when put into a boiler without being tested usually contains one or more that leak due to defective welds and the cost of removing and replacing one leaky flue in a boiler is greater than the cost of testing the whole set in the machine described.

SUPERHEATER FLUE SWAGER

A very compact and well designed pneumatic swager for superheater flues is illustrated in Figs. 4 and 5. The frame of this machine is built up of two 10-in. channels connected by suitable angle irons and straps, the upper part containing an 8-in. freight car brake cylinder. The cylinder is fitted with a piston whose stem, 2½-in. in diameter, passes downward through the lower head. Around the stem there is a heavy compression spring acting on the lower face of the piston and the lower end of the piston rod carries a follower for the upper die. This acts as a ram for the swaging process. The dies are forged solid from steel locomotive axles. As originally designed, it was necessary for the operator to step on a foot treadle for every stroke of the piston, and to eliminate this, the swager was equipped with the automatic valve shown in Fig. 5. A 1½-in. three-way

cock carrying a two-arm tappet is cut into the feed pipe and this tappet is acted upon to operate the valve by an arm pivoted on the frame and connected with the upper die. As the latter rises and falls, the outer end of the arm is rocked slightly in the opposite direction and operates the three-way cock. The points of contact of the end of the arm and the tappet consist of hardened steel spring plungers to eliminate wear. The machine operates at about 300 strokes per minute and has given hardly any trouble since its installation about three years ago.

RADIAL STAYBOLT CUTTER

The special bolt cutter illustrated in Fig. 6 was designed for turning and cutting the taper thread under the button head of a radial staybolt. This machine was originally a 1½-in. double head bolt cutter of standard design and was rebuilt by the writer for the purpose mentioned. As can be

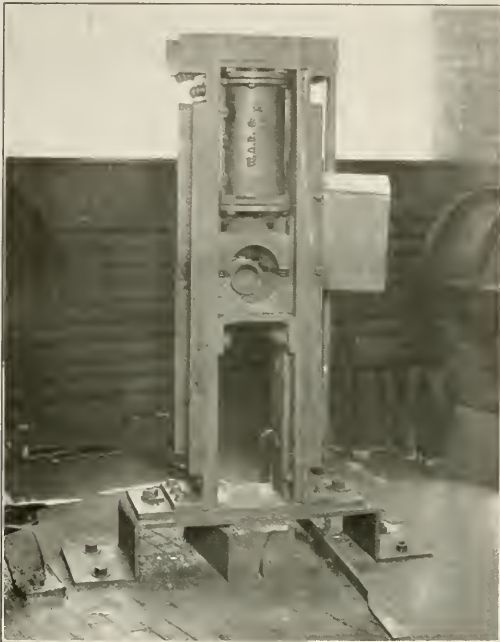

Fig. 4—Superheater Flue Swager

seen from the illustration, each spindle is provided with a reversible gear and a clutch drive mounted on a steel plate superstructure. The die heads are arranged to be opened by hand by the lever at the side of each head. The top end of the staybolt is guided by an interchangeable sleeve in the spindle. Four of these sleeves are provided to take care of all sizes of staybolts from 1¼-in. to 1¾-in. and of any length. One end of the sleeve has a plain hole and the other end a threaded hole of the respective size of the bolt to be guided. The die heads used are known as the Cook die head, manufactured by the Detrick & Harvey Company, Baltimore, Md. This type of head is particularly adapted for the work. The left hand head is equipped with plain cutters which convert it practically into a hollow mill or box tool. The right hand head contains the threading dies. The automatic knock off on the die heads is not used, because the recess under the button head of the bolt is cup shaped and would not permit opening the ties before

the bolt is backed out a little distance. This is the reason for the reversible drive.

In operating the machine the bolt is placed in the floating holder shown in the left hand vise in Fig. 6. The top end of the rough bolt, Fig. 7 is entered in the guide sleeve in the spindle; the die head is closed and the bolt is fed

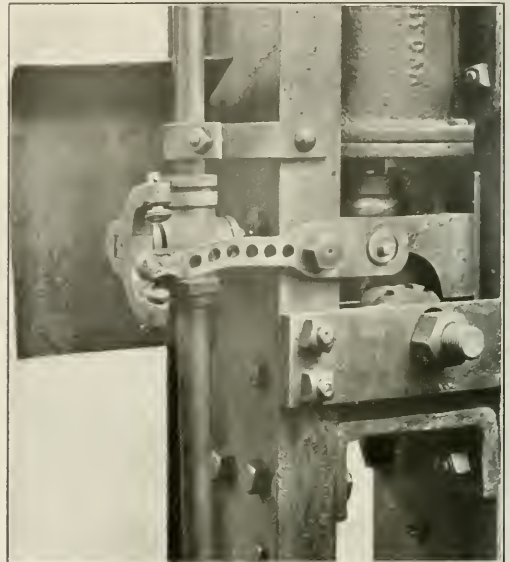

Fig. 5—Automatic Valve Used with Flue Swager

into the proper depth by hand. After this operation, the bolt looks like *B*, Fig. 7. Next the bolt is placed in the right hand head in the same manner. The guide sleeve in this spindle is threaded and can be adjusted so as to bring the threads on both ends of the bolt in correct lead. The

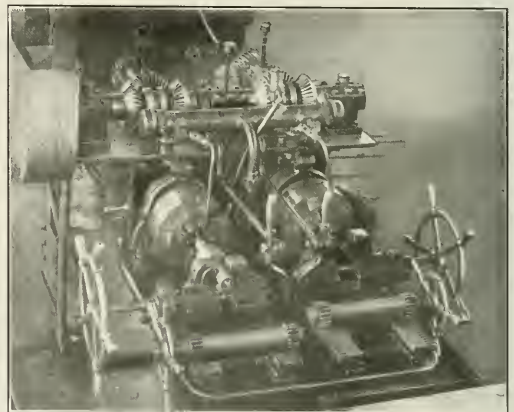

Fig. 6—Radial Staybolt Cutter

clutch on the right hand die head is adjusted to slip before any damage can be done to the threading dies, in case the operator should run the die up against the shoulder of the bolt head. Before opening the die head the machine

is reversed for about 1/4 in. so the dies clear the cupped shoulder of the button head. After this the bolt appears as shown at C, Fig. 7.

Originally these bolts were turned and threaded entirely on the engine lathe. Sometimes, on rush jobs, four or five

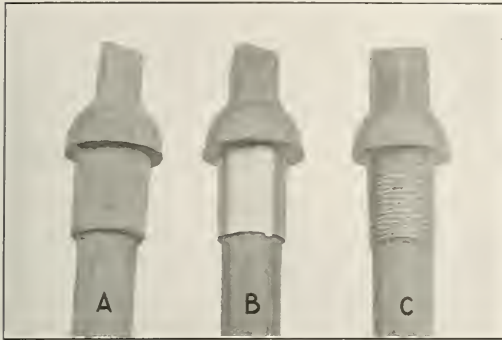

Fig. 7—Radial Staybolts Before and After Machining

lathes were working on radial staybolts, and with this method of manufacture they cost about 15 cents each. With this bolt cutter the cost per bolt has been reduced to about two cents per bolt. Furthermore, the work on the bolts is now done entirely in the boiler shop under the supervision of the boiler shop foreman and a lot of unnecessary handling has been eliminated. This machine is convenient to operate and has given excellent service for over three years.

SOMETHING NEW IN REAMERS

A new method of making inserted-tooth, high-speed steel reamers and milling cutters was described by T. O. Martin, blacksmith foreman, Illinois Central, Jackson, Tenn., in a recent issue of Reactions, and it is very timely on account of the present prices of high-speed steel. The helical reamer described in this article, and illustrated in Fig. 1, was made of high-speed steel blades welded into a Thermit steel body, and the cost was \$15.25 as against \$68.45, the lowest quotation of a machine tool manufacturer for a reamer of the

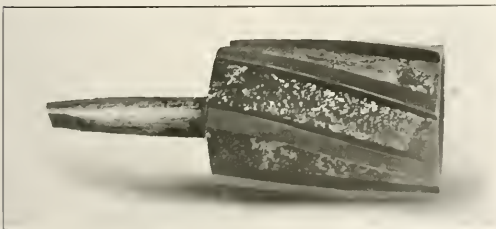

Fig. 1—A Helical Reamer Made of Thermit Steel and High Speed Blades

same size and kind. This reamer has been in service at the Jackson shops for about a year, and so far has proved an efficient tool.

In making a reamer by the Thermit steel process, first make the blades from high-speed steel of helical shape to conform to the required length and pitch of the reamer. Then bore out a cylinder with the same size and taper of reamer which it is desired to reproduce. Set the blades up in this cylinder, spacing them properly, with the cutting edges firmly

against the cylinder wall and leaving sufficient clearance behind the cutting edges of the blades. Then place a carbon steel core in the center. The carbon steel core is machined at one end to fit a Morse taper socket. Fill the space between the core and the cylinder with molten beeswax and allow it to cool. Then remove the contents of the cylinder intact; that is, the beeswax body, iron core and cutter blades. This can be accomplished very easily by heating the outside of the cylinder, thus expanding it and melting the outside surface of the wax so that it can be slipped out without



Fig. 2—Reamer Blades Inserted in Wax and Ready for the Mould

trouble. The next step in the operation is to trim the wax between the blades as shown in Fig. 2. This matrix is then ready to be placed in a regular mould for Thermit welding, as shown in Fig. 3.

In moulding, the reamer is placed upside down in the

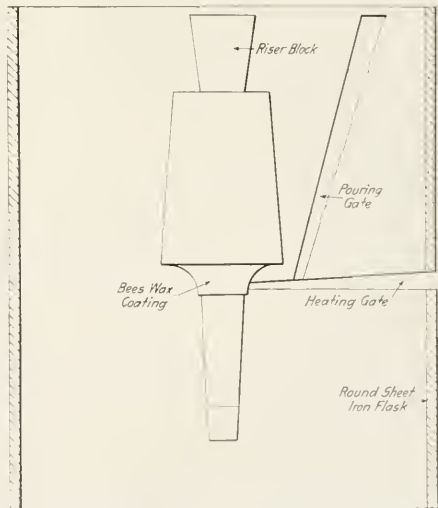

Fig. 3—Set Up of Mould Before Pouring

box and the moulding material is rammed to within about 1 1/2 in. of the blades. At this point the heating gate is directed against the carbon steel core, with the pouring gate left about 3 in. away from the side of the core, as shown.

The mould is then rammed up, the same as in the case of a broken locomotive frame. When the mould is filled up to the top of the reamer, a wooden riser is put in place, which will permit of a free flow of the molten Thermit steel into the mould.

Heat up the mould with a preheater to a good white heat (this also melts out the wax), and plug up the heating gate. Then ignite the Thermit, and, after the reaction has taken place, tap the crucible. It is usually safe to knock down the mould in about one-half hour, and cut off the riser with an oxy-acetylene cutting torch.

Contrary to expectations, it has been found that the intense heat of the Thermit reaction actually improves the quality of the inserted blades, and no subsequent heat treatment is necessary. This may not appear reasonable, but it is perhaps explained by the fact that all air is excluded from the mould.

The reamer shown in Fig. 1 was made in practically the same time as would be required to weld a locomotive frame, and, as stated before, has given good service for a considerable time. In addition to reducing the cost, the above method of making high-speed steel tools possesses the added advantage that it is possible to obtain them at any time when desired.

GROUP INSURANCE

BY A. J. SCHNEIDER

The ever-growing serious problem of labor turnover is caused largely by the high prices which munition concerns are able to pay for all kinds of work. But whatever the cause of the problem, its solution is equally necessary to railroads, supply firms and all old-established companies. Something must be done to hold the older employees on the job.

Of the methods by which it is proposed to decrease the labor turnover, one of the most promising is group insurance, and this plan is being tried out by the Cincinnati Planer Company. This plan was put into effect on October 4, 1917, and while it is too soon to prophesy its success or failure, certain results are already noticeable. There is a considerable increase in the applications to the employment department. Group insurance affords a good talking point for the employment manager, the superintendent, the foreman, etc.

The actual insurance, of course, is provided by insurance companies, and the average cost is \$4 per year per employee (less than two cents per day), depending on age and length of service. In view of the small cost, the plan is almost sure to pay for itself.

In placing the plan before the employees, a letter typewritten on the regular company letterhead and made as short and plain as possible was sent directly from the manager to the home. It was hoped in this way to cause a wider discussion and make the employee feel that the company had a personal interest in him.

The letter pointed out that employees needed insurance for the protection of their dependents and went on to say that those who had been in the constant employ of the company for three months were to be insured by the company for \$500, six months for \$600, one year \$700, and \$100 additional insurance each year until a maximum amount of \$1,500 had been reached. The insurance was made retroactive, and employees were credited with the amount of insurance to which they were entitled by the above plan. The letter stated that the action was entirely voluntary, and that it constituted no contract to the employee and conferred no legal right on him. In other words, it did not change the employee's right to leave, nor the employer's right to dismiss him from the service of the company.

All of these benefits were provided at the expense of the

Cincinnati Planer Company, no deductions from wages or contributions of any kind being required from the employees, and all rights or benefits ceased whenever the employee left or was dismissed from the service. In addition to offering life insurance protection, the contract provided an income in case of permanent disability, whether resulting from disease or accident.

One part of the proposition which received considerable study was the question of whether the insurance should be based on wages or length of service. It was decided that the latter plan was the simpler and more efficient for several reasons. In the first place, it was felt that group insurance would be adopted by many employers in the near future, and if the plan was based on wages there would be nothing to hold the employees. In other words, if two shops in the same locality both had insurance based on income, an employee insured for \$1,000 would have no incentive for remaining with the old organization if he could get the same or better wages in the new shop. Therefore, it was considered best to base the insurance on length of service, which has the additional advantage of being very simple and reduces the mechanical work involved.

The work required in connection with the plan of group insurance requires very little time, and consists of a record card giving the name of the company, employee, birthday, address, beneficiary, etc. After this card is filled out, no work is required unless the employee leaves the service or dies, except an occasional checking of invoices and making an occasional report.

SPECIAL TOOL FOR TURNING UP AIR PUMP PISTON RINGS

The tool illustrated below is used in the West Burlington (Iowa) shop of the Chicago, Burlington & Quincy for cutting off and facing air pump piston packing rings. Two sizes are in use, one for 9½-in. and the other for 11-in. rings. The tools are attached to the upper head of a 36-in. vertical turret lathe, the relative position of the work and the tools being as shown in the illustration.

The thickness of the rings can be varied by changing the adjustment of the facing tool. By raising or lowering the sides of the holder the upper cutting edges of the inner

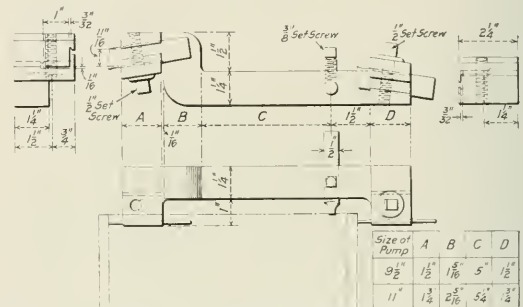

Tool Which Cuts Off and Faces Piston Rings.

and outer cutting-off tools can be brought in line. Any variation in the thickness of these tools is taken care of by the light cuts taken across the top with the facing tool. By decreasing the depth of the cut which it is necessary to take with the parting tool, thinner tools can be used, thus reducing the amount of metal wasted. In addition to this, there is a considerable saving in the time required to make the rings.

MAKING COLD CHISELS

BY G. J. BRUNELLE

Assistant Blacksmith Foreman, Boston & Maine, North Billerica, Mass.

There should be no more guesswork in the making of good chisels than in the making of good taps, reamers, milling cutters, etc. In the first place, a suitable steel must be procured, and manufacturers usually carry on hand a special S5 to 95-point carbon steel for this purpose. It is rather coarse grained in the annealed bar, yet capable of refining at the critical point when forged and hardened at the proper heat, and is very tough. It is important to know that carbon, while imparting hardness to steel, also increases its brittleness, and a chisel made of steel with too high a percentage of carbon is dangerous to use.

Should one of the alloy or high-speed steels be selected,



Fig. 1—A 5/16-in. Cape Chisel Driven Through 3/4-in. Stock

it must be plainly marked, for the method of treatment is entirely different from that of carbon steel, and the toolmaker should be able to tell at a glance with just what kind of steel he is working.

After securing a good steel, the next requisite is a good toolmaker, and it is a mistake to give the work to a cheap man, novice or apprentice. The excuse is generally made that the job is good practice for beginners, as the chisel is one of the cheapest tools. This is true enough if the chisels are being made to give a man experience, but if they are required for use they should be made by the most experienced workman available, because a man can employ with profit as much skill in making a good chisel as in making a good lathe tool. Good chisels, like those illustrated in Figs. 1 and 2, do not break with fair usage nor require frequent grinding, and are highly prized by good mechanics.

Uniform practice in working the steel is to be desired, and for this purpose printed instructions should be issued. Manufacturers generally are glad to furnish special instructions with each kind of steel, but these neatly printed booklets are too often allowed to lay in the office of the man responsible for the purchase, only to be consulted after a lot of tools have proved defective.

In case no special instructions are given, it is good practice to find, either by heat measuring instruments or by tests, at just what temperature the steel refines in hardening and retains its greatest toughness. This is commonly done by drawing out a test piece to about 1/2 in. square, making a number of deep cuts 1/2 in. apart, as shown in Fig. 3. Allow the test piece to cool and reheat to a tapering heat; that is, with section 1 white hot and section 7 a low red. It should then be quenched in oil or water, as the case may be, at a rising heat. Do not heat the test piece higher than is wanted and allow it to cool to the desired temperature. If the heat is unsatisfactory, allow the test piece to cool and try again. When it is heated to the correct temperature, cool suddenly, as described above, and dry. Then break off the sections at

the cuts, beginning at section 1, noting at the same time how much pressure is required to break off each section. The first section will break off easily and show a coarse fracture. The next will require more pressure and show a finer grain, and so on, until a section is found that breaks off with difficulty and has very fine grain. This is the model fracture for the hardener to work to on that particular steel. The heat may not be remembered, but the grain of fracture is there to make comparisons by and let the hardener know if he is heating too high or too low.

The general rule is that steel gives best results when hardened at the lowest heat at which it will harden. Referring back to the test piece, it will be found that back of the section showing the finest grain is another that breaks off with great difficulty and yet shows a coarse grain similar to the annealed bar. This section will be found to be soft, showing that the part was not heated to the point of recalcence; that is, the temperature at which steel hardens. Now it often happens that, while trying to keep as near to that low heat as possible, which is absolutely necessary to get good results, a hardener allows his furnace to get just below this point. The result is a lot of soft tools, for which he will be more severely criticised than if he had been careless and had kept his furnace well above the required heat.

The best way to cut the stock for chisels is at the shears, and neither the knives nor the steel will be injured if the bars are first annealed by drawing the material through a furnace or over a fire at about 200 to 250 deg. F. Should this annealing be omitted, the ends are liable to be shattered while being cut and develop flaws.

In forging, a furnace is more to be preferred than an open fire, and the steel should not be held at a high heat too long. On the other hand, the steel must not be worked too cold, for the closer packed the grain of the steel the stronger and tougher it will be. Enough material should be trimmed from the end of the chisel to get rid of any fire or water checks, like those shown in Fig. 4.

The shaping of a chisel is important and certain general



Fig. 2—A One-Inch Flat Chisel Driven Through 1 1/4-in. Stock

rules apply to all kinds. Each should be forged so that the flat surfaces of the blade are a continuation of the flat surfaces of the stock, and if the chisel is to stand up under hard usage, the cutting edge must be in the center line of the body of the chisel. It is also a mistake to forge a chisel too blunt, as a long tapered chisel having a certain amount of spring will absorb many a shock that would break a thick, blunt cutting edge.

The flat chisel shown in Fig. 4, when made of 7/8-in. octagon stock, should be tapered back about 3 1/2 to 4 in., making an angle of approximately 12 deg. and should flare out slightly at the point, so that the cutting edge will be about

one inch wide. Fig. 5 shows two extra good chisels of this kind (for chipping only), which are made by drawing out the blades about $\frac{1}{4}$ in. thick and $3\frac{1}{2}$ in. long. To give them the proper stiffness and durability they should be hardened and tempered the whole length of the blade. This permits the use of many short chisels that would otherwise be scrapped.

In making the round nose and cape chisels, illustrated in Fig. 6, two points are to be remembered. It is important to give the cutting edge clearness and to temper the blade at least two inches back from the point.

These are three of the more common shapes, but the same intelligent care required for success with these will produce good results when applied to making larger tools of the same type, such as handle chisels, chisel bars, etc. All chisels, after being forged to shape, should be cooled and ground before hardening, and a clearance angle of about 30 deg. for flat and cape chisels has proved to be satisfactory.

Heating chisels properly for hardening in an ordinary

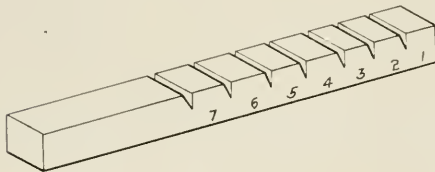

Fig. 3—Test Piece

furnace is not as simple as commonly supposed. Care should be taken to heat the heavier part of the chisel first, allowing the thin edge to come to the required temperature last. This prevents "soaking" the very part of the chisel that should be the strongest, and soaking at a low heat is nearly as bad as overheating. The quenching should be done in brine and at the lowest heat at which the steel will retain its full hardness, which is generally about 1350 deg. F.

To find out whether the heat is too high or too low, test the tool with a file or chip off a little piece from a chisel occasionally and compare the fracture with that of the test piece showing the best grain. Whether the chisels are to be tempered in oil or run down to color, quench far back from the edge, at least $2\frac{1}{2}$ in., and stir up and down while cooling to avoid making a sharp line of demarcation between the hot and cold portions, thus forming a water crack like that shown in Fig. 4. It is a very common and grave fault

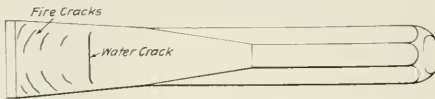

Fig. 4—Flat Chisel

to quench a chisel only about $\frac{3}{8}$ or $\frac{1}{2}$ in. from the edge, because at that point the section is thin enough to produce a water crack readily, and these rarely appear on the surface until the tool is in use.

By far the best mode of tempering is in the oil bath, and for ordinary hand chisels the writer's experience has been that the best results are obtained at temperatures of about 570 deg. F. This leaves the chisel hard enough for ordinary chipping and reduces the liability of a broken tool when splitting a nut or wedging off a patch. Chisels used exclusively for chipping and air hammer tools should be made considerably harder.

The redressing of chisels requires more care than when new chisels are being made. A piece of hardened steel is in some respects like a piece of glass. When heated at a rate

that is faster than that at which the heat can be absorbed, the hotter parts expand beyond the elastic limit and break away from the cooler parts. Of course the elastic limit of steel is much higher than that of glass, but the number of chisels returned full of fire cracks is abundant proof that it is frequently exceeded. Fig. 4 is a good illustration of a chisel having both fire and water cracks.

A chisel may be shaped right and hardened right and like any other tool may be spoiled in the grinding, so it is important not to overheat the cutting edge while grinding. It is also true that each time a tool is redressed it becomes more

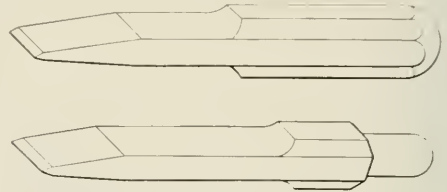

Fig. 5—Chisels Drawn From Short and Scrap Pieces

difficult to make it stand up, because something has been taken out of the steel which can never be replaced.

For general purposes chisels should be ground to an angle of about 30 deg., but this may not be the best angle for a special case. If a machinist grinds his lathe tools blunt to cut cast iron and thin to cut soft steel, why not apply the same rule to cold chisels? Some men seem to think that if a chisel is tempered right it can be neither bent nor broken, but these are generally the kind that will try to take off a $\frac{1}{2}$ -in. chip of Thermitic metal with a chisel $\frac{1}{8}$ in. thick at the point. A common method of breaking the corners of a chisel is to drive it under a rivet head, and this may be

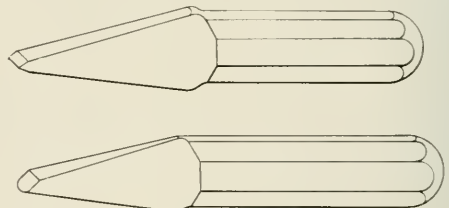

Fig. 6—Cape And Round Nose Chisels Showing Clearance

prevented by starting the cut about $\frac{1}{16}$ in. above the bottom of the head. Connecting two cuts not in the same line, or cutting to a curved line with a wide chisel is also bad practice, and of course there are many other ways of abusing chisels. Yet mechanics will continue to break good tools time and again in the same way without ever looking for the cause.

No one ever seems to take any account of these faults, because chisels are so cheap and easily obtainable, but if everything were taken into consideration—the cost of the steel, the time lost by the mechanic and helper and the time of the toolmaker and helper—it would be found to be expensive carelessness.

SAFETY AND SANITATION WORK SHOWS RESULTS.—The Industrial Commission of Wisconsin reported on December 22 that during the last half of 1917, industrial accidents in Wisconsin workshops and factories showed a reduction of 14 per cent from the corresponding period of 1916. This is due to the special effort made by the commission to interest foremen and superintendents in safety and sanitation work.



SUNDSTRAND TOOL ROOM LATHE

The new 16-in. quick change lathe known as the Sundstrand and illustrated below was recently developed by the Rockford Tool Company, Rockford, Ill., and extra heavy construction combined with maximum convenience of operation make it especially adaptable to railway tool room service. The lathe is built to stand heavy cuts and another feature is the use of both speeds of the countershaft to drive the spindle

is graduated for convenience in drilling. The lead screw is not splined and being used for thread cutting only, should retain its accuracy a long time. Any number of threads from $1\frac{1}{2}$ to 80 per inch, including the $11\frac{1}{2}$ -in. standard pipe thread, can be cut.

The apron is of double construction, all gears and studs being supported at both ends. It is securely fastened to the carriage and is designed to withstand heavy stresses. A positive lock is provided in the apron to make it impossible

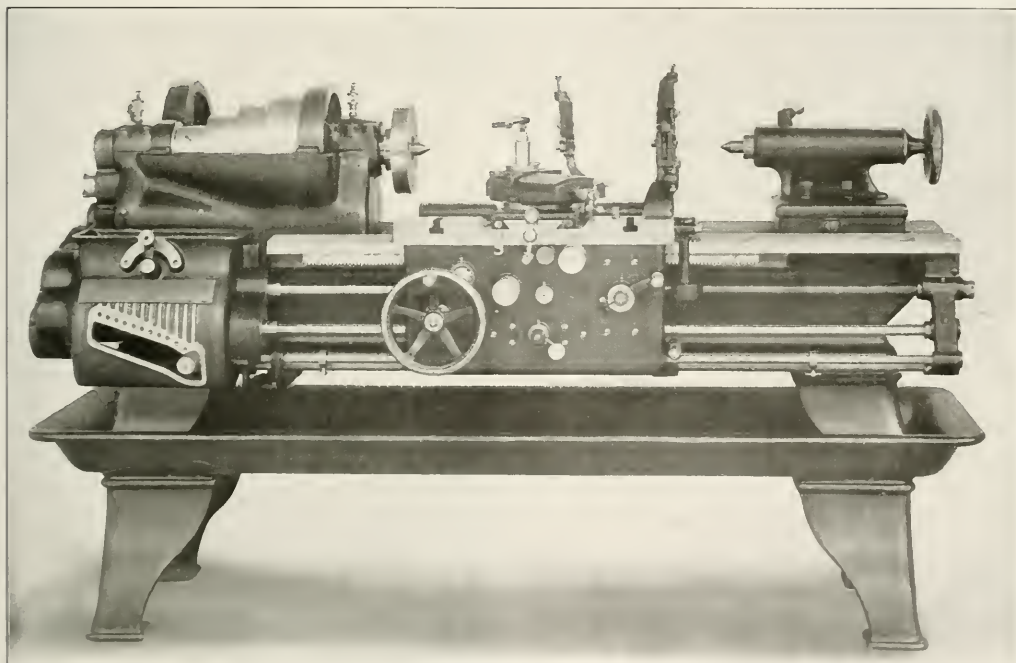

A Quick Change Lathe for Tool Room Work

in the same direction, which doubles the number of available speeds and prolongs the life of the belt.

The bed of the lathe is heavy and strongly braced. The headstock is ribbed and securely clamped to the bed to prevent chatter. There is a single back gear and a four step cone pulley is regularly furnished. The bearings for the spindle are phosphor bronze of generous proportions and are provided with sight feed self-oilers. The end thrust on the rear bearings is taken by a large ball thrust bearing. The tail stock is of the cut away type and the tail spindle

for the lead screw and the feed rod to be engaged at the same time.

The reverse mechanism is mounted in large bearings in the headstock and an independent feed rod is provided which may be reversed by a lever shown on the right side of the apron.

A well designed, quick change gear box is mounted on the front of the bed and by the use of two handles it is possible to quickly obtain any one of 36 different speeds.

Considerable attention has been given to the design of a

suitable taper attachment and all carriages are drilled to take the attachment in case it is needed later on.

There is also a special relieving attachment for accurately backing off or relieving the teeth of hobs, cutters, taps, etc. It is driven from the back gear through a quadrant firmly clamped on the lathe bed in the rear of the headstock.

The regular equipment furnished with this lathe includes a special gear for cutting the 11½-in. thread, large and small face plates, a double friction countershaft, oil pans and suitable wrenches. Following is a list of important dimensions of the lathe:

Swing over bed.....	163¼ in.
Swing over carriage.....	97¼ in.
Distance between centers.....	32 in.
Length of bed.....	6 ft.
Width of bed.....	15 in.
Width of belt.....	23¼ in.
Tool post takes ⅝ in. by 1¼ in. tool.	
Revs.....	from 6 to 320 per in.
Net weight, approximately.....	2,800 lb.

PAINT SPRAYING SYSTEM

Many methods of applying paint in the form of a spray by means of compressed air have been suggested, and one that is used successfully is the Aeron system developed by the De Vilbiss Manufacturing Company, Toledo, Ohio. This system is used extensively in the industrial field and has wide possibilities in the railroad field. It is now used

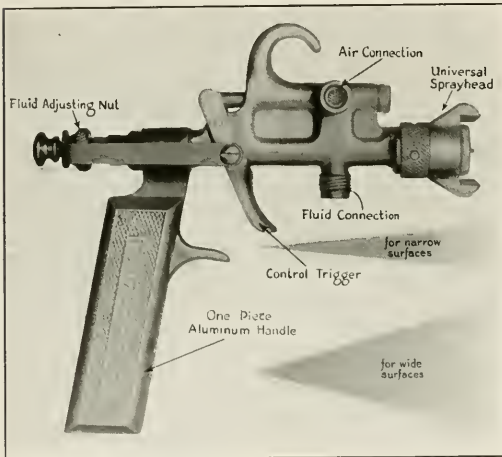

Fig. 1—Paint Spraying Nozzle.

by some roads for painting equipment and buildings. It is a great time and labor saver and as such should be seriously considered by railway men. The Aeron system is so designed that it may be operated without materially wasting paint.

The nozzle is in the form of a pistol with the control trigger always under the operator's finger and within four inches of the spray head. This allows the paint to be applied exactly where it is needed and reduces to a minimum any loss in paint. An adjustable nozzle is provided which governs the width of the spray. All kinds of varnishes, enamels, lacquers and oil paints may be used with the Aeron system, which is easy to install and operate and does a uniformly high grade of work. It may be used to good advantage in the painting of car bodies, trucks, stencils, locomotives, car interiors and exteriors. Among the advantages of paint spraying as compared with the old hand brush method, may be mentioned the following: Much greater speed, less paint

used, less wasted, rough and inaccessible surfaces covered more uniformly and the possibility of cleaner and better working conditions. A portable painting equipment has been developed which consists of a suitable air compressor,



Fig. 2—A Difficult Painting Job Made Easy.

belt driven from a small gasoline engine and mounted on a portable truck. A paint tank and regulating head, together with an air receiver are also mounted on the truck. Suitable hose and connections are provided for use with the



Fig. 3—Paint Sprayer Used for Stenciling.

nozzle. Where compressed air is available the air compressor and gas engine would be unnecessary.

The really vital part of the Aeron equipment is the nozzle, which is shown in Fig. 1 with the connections and attachments plainly indicated. The flow of air and paint is under the instantaneous control of the operator by means of the

trigger and the universal spray head produces a flat spray which may be adjusted horizontally or vertically, or for wide or narrow surfaces. Wide surfaces may be covered with rapidity and uniformity.

In operation, the paint tank regulating head inlet is connected by 1/2-in. air hose to the compressor air system. One or more nozzles are then connected by 3/8-in. air hose and 1/2-in. fluid hose to the regulating head outlet. The paint is put into the tank through a filler plug hole. With the regulator shown in Fig. 2 and the fluid adjusting nut on the nozzle, the air pressure is controlled to meet varying conditions of size of nozzle, viscosity of paint, height of nozzle above tank, etc. Special extension nozzles are provided for use in unusually difficult places.

Painting car trucks is a slow, troublesome job by the old paint brush method and Fig. 2 shows how the work may be done by use of the Aeron system. Fig. 3 shows it used in stenciling a car body. In fact, the system is very flexible and may be easily adapted to the varying conditions that have to be met in railway practice.

A PORTABLE VISE AND BENCH

Strength and maximum convenience in handling are the points especially emphasized in a new portable vise which is manufactured by the Henderson Electric Company, Ampere, N. J.

The vise is made in two patterns, the larger of which is shown in the illustration and weighs 225 lb. The table is 30 in. by 36 in. by 2 in. and the legs are made of 2-in.

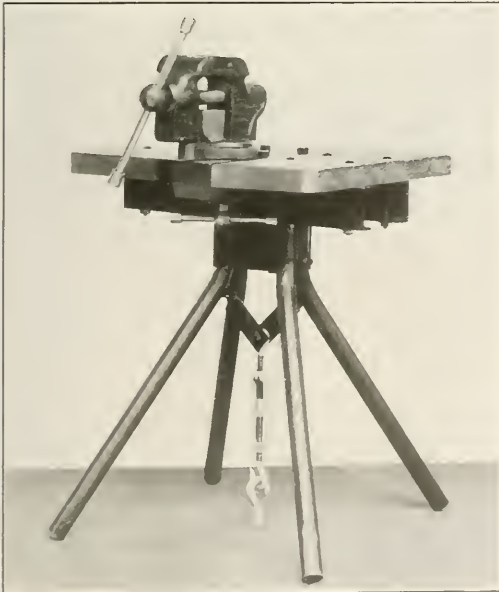

A Convenient Portable Vise

pipe. To insure solidity, the table is fastened to the floor by means of a turnbuckle and lag screw which is clearly shown in the illustration.

A portable vise of this kind should be of value in shops and roundhouses where it could readily be placed near the location of the work and thus result in the saving of many steps.

A. & Z. BRAKE BEAM HANGER

A new brake beam hanger recently devised by L. E. Atwell, roundhouse foreman, and C. A. Zweibel, supervisor of car repairs, of the Atlantic Coast Line, is of especial interest. Simplicity, ease in application, durability and cheapness are among the advantages claimed for the A. & Z. hanger, as it is known, and it is being used successfully on the tenders of several Atlantic Coast Line locomotives. The hanger is composed of two forged wrought iron pieces which are interchangeable.

In order to apply the hanger, which may be done easily from the outside, it is simply necessary to remove the brake key and shoe, and lower the brake beam. The two sections of the hanger are then suspended from the hanger bracket and allowed to come together at the center which automatically locks them in place. To complete the job, it is only necessary to raise the brake beam, hook the bottom of

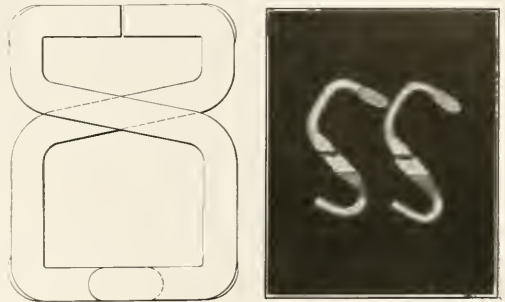

A. & Z. Brake Beam Hanger

the hanger into the slotted hole in the brake head and apply the brake shoe and key. The corners are reinforced and stiffened by extra ribs and the lap joint in the bottom of the hanger increases its stiffness. Obviously, there are no nuts or cotters to work loose and the hanger should prove durable as well as cheap.

CARBOCOAL—A NEW FUEL

A new commercial process for converting bituminous coal into a fuel which is smokeless and has the characteristics of anthracite coal, has been invented and perfected by C. H. Smith, who has been working on this new process for some time in conjunction with Blair & Company, of New York. The bituminous coal is taken in its raw state and subjected to a distillation process at relatively low temperatures, which distills off vapors and permanent gases, leaving what is called Carbocoal to be made into briquettes. An important feature is that valuable by-products are obtained from the gases, the revenue from the sale of which largely compensates for the cost of the process.

The residue from the distillation is pressed into hard and durable briquettes. These briquettes are practically pure carbon, having only one to four per cent volatile matter. They provide an intense fire and are adaptable for use on locomotives where high steaming rates are required. The adaptability of this fuel for locomotive use has been determined by actual locomotive tests, at which high rates of combustion were obtained with practically no smoke. It has been found particularly suitable for use where limited grate area is obtained and restricted boiler capacity requires an efficient fuel. It is easily handled; the briquettes do not readily disintegrate.

The accompanying table shows the products obtained from

the raw bituminous coal by the distillation process. The coal tar products are recovered in their primary stage, there being available some 20 gallons of tar oils for the market as compared with four or five gallons from the same grades of coal in the ordinary carbonization process. Many of the

Raw Bituminous Coal—2,000 lb.
Carbocoal Briquettes—1,440 lb.
Gases and Vapors—560 lb.
Vapors—360 lb.
Tar Oils—Benzol, Toluol, Naphthalas, Motor Spirit, Cresosote, Oils, Tar Acids, Lubricating and Fuel Oils, Anthracene, Pitch and other tar oil products.
Ammonical Liquor—Ammonia (Concentrated), Sulphate of Ammonia, Cyanogen, Pyridene bases and other nitrogen compounds.
Permanent Gases—200 lb.
These are used to provide heat for the distillation process, or may be used for commercial purposes.

by-products which are obtained by this process are in great demand for use in the manufacture of explosives.

Such a fuel will find a field on railroads, for domestic use, in stationary and marine plants where smokeless operation is desired, and for kilns and gas producers. This process is being handled by the International Coal Products Corporation, of which Mr. Smith, the inventor of the process, is president. An experimental plant has been in operation at Irvington, N. J., and plans are now under way for the construction of new plants.

A HIGH LIFT INDUSTRIAL TRUCK

In the efficient handling of freight and stock from platform to storeroom, different forms of industrial lift trucks are becoming more and more important factors and their use has spread to railroad repair shops and freight houses. One of these trucks, recently developed by the Lewis



Model 10 W S B Jacklift Master Truck

Shepard Company, Boston, Mass., intended especially for railroad work, is shown in the illustration.

With a capacity of 3,500 lb. and large rear wheels to insure easy rolling, it combines the added advantage of a universal joint which permits the load to be raised with the handle in any position. In this way it is possible to use the truck in freight cars and other cramped quarters hitherto inaccessible, and a total lift of $2\frac{1}{2}$ in. allows the wooden

platforms to be pulled over inclines and other irregularities in the floor.

The load is elevated by a combination of levers requiring from four to six short strokes of the handle and a ratio of 40 to 1 gives a powerful purchase. In lowering, a release check permits the load to descend slowly to the floor and eliminates the possibility of spills.

At one freight depot where this truck is in use, all incoming freight is unloaded directly onto small platforms made for the purpose. Platform and freight are then moved by the aid of a truck to their destination without rehandling.

ALL METAL STEAM HEAT CONNECTION FOR CARS

With a view to providing a connection for the steam lines for passenger cars that would reduce the trouble and expense incident to the use of rubber hose, the Barco Manufacturing Company, Chicago, has developed a connection in which no rubber is used. This device has recently been placed upon the market after it had been in use for four years.

The Barco car steam heat connection is made up of two Barco joints of a special type and two sections of extra heavy steel pipe. Any standard steam-heat coupler head can be used on it. A locking clamp secures the upper flexible joint to the train line end valve, making it impossible for the connection to fall to the track. If desired lagging can be applied to the connection, but in most of the installations this has

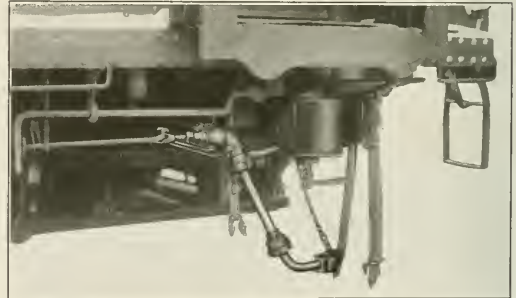

Passenger Car Equipped with Barco Steam Heat Connection

not been done. It is desirable to have a flexible bracket at the end of the train line of a type similar to that shown in the illustration.

No special tools are required to apply or remove these connectors. They will couple to cars equipped with rubber hose as well as to those having the Barco connection. The joints are more flexible than rubber hose, which makes them easier to couple. They will stand the full boiler pressure of the locomotive without leaking or bursting. The steel pipe gives a larger opening for the passage of the steam than rubber hose and eliminates the trouble due to the rubber lining becoming loose and stopping the pipe or catching in the valves. The all-metal connections remain serviceable for a long time and do away with frequent renewals.

EXPORTATION OF SCRAP IRON OR STEEL.—The War Trade Board calls attention to the fact that the exportation of scrap iron or steel requires an export license, and that any shipper who exports under any different classification (such as second-hand rails, car wheels, etc.) any articles manufactured of iron or steel which are exported for the purpose of being scrapped at destination is guilty of false declaration and is subject to such penalties therefor as the law provides.

Railway Mechanical Engineer

(Formerly the RAILWAY AGE GAZETTE, MECHANICAL EDITION
with which the AMERICAN ENGINEER was incorporated)

PUBLISHED ON THE FIRST THURSDAY OF EVERY MONTH BY THE
SIMMONS-BOARDMAN PUBLISHING COMPANY

EDWARD A. SIMMONS, *President* L. B. SHERMAN, *Vice-President*
HENRY LEE, *Vice-President and Treasurer* M. H. WILSON, *Secretary*
WOOLWORTH BUILDING, NEW YORK, N. Y.
F. H. THOMPSON, *Business Manager*, CHICAGO.

Chicago: Transportation Bldg. Cleveland: Citizens' Bldg.
Washington: Home Life Bldg.
London: Queen Anne's Chambers, Westminster.

ROY V. WRIGHT, *Editor*
R. E. THAYER, *Managing Editor*

C. B. PECK, *Associate Editor* E. L. WOODWARD, *Associate Editor*
A. F. STEUBING, *Associate Editor* C. W. FOSS, *Associate Editor*

Entered at the Post Office at New York, N. Y., as mail matter of the second class.

Subscriptions, including the eight daily editions of the *Railway Age* published in June in connection with the annual convention of the Master Car Builders' and American Railway Master Mechanics' Association, payable in advance and postage free: United States, Canada and Mexico, \$2.00 a year; Foreign Countries (excepting daily editions), \$3.00 a year; Single Copy, 20 cents.

WE GUARANTEE, that of this issue 8,100 copies were printed; that of these 8,100 copies 6,955 were mailed to regular paid subscribers, 115 were provided for counter and news companies' sales, 330 were mailed to advertisers, 162 were mailed to exchanges and correspondents, and 538 were provided for new subscriptions, samples, copies lost in the mail and office use; that the total copies printed this year to date were 24,900, an average of 8,300 copies a month.

The RAILWAY MECHANICAL ENGINEER is a member of the Associated Business Papers (A. B. P.) and of the Audit Bureau of Circulations (A. B. C.).

The shops of the Pennsylvania at Blairsville, Pa., on the Conemaugh division—a machine shop, a blacksmith shop and a boiler house—were destroyed by fire on February 5. Estimated loss, \$15,000. The fire occurred at 3 a. m. when the temperature was 10 deg. below zero.

The executive committee of the Master Car Builders' Association has issued Circular No. 26 announcing that the Interstate Commerce Commission has extended the date effective for the application of safety appliances to cars to September 1, 1919. To conform thereto, paragraph (m) of Rule 3 should read: "After September 1, 1919, no car will be accepted in interchange unless properly equipped with United States safety appliances or United States safety appliances, standard."

The shopmen of the Grand Trunk are to have a general increase in pay, aggregating, it is said, more than \$500,000, on all of the company's lines. The advance is in accordance with the decision of a board of conciliation which has recently made a unanimous report. The men affected are the machinists, the boilermakers and the blacksmiths, said to be about 1,300 men in all. The report also provides that grievance committees shall be established in the shops; the working day is to be nine hours and the rate of pay is to be advanced 50 per cent for overtime and for work done on holidays. The agreement runs one year from March 1.

A pledge to save fuel oil is called for by Albert E. Swabacher, United States fuel administrator for California, who has sent a letter to all locomotive enginemen in that state. The Southern Pacific is the greatest consumer of fuel oil in that state and the co-operation of its employees is expected to mean in the aggregate a great saving for other industries. Mr. Swabacher's letter says that the storage supply of fuel oil in California is decreasing at the alarming rate of 1,100,000 barrels a month. The abnormal demands of the last three years have decreased the available storage supply by one-half. The pledge cards, sent to the firemen of all California roads, are being signed and returned to the fuel administrator.

Conference on Conservation of Railway Fuel

A conference recently was held in Chicago between Major E. C. Schmidt, representing the Fuel Administration, and a number of representatives of the railways regarding methods

which should be adopted to promote greater conservation of fuel by the railways. Major Schmidt, who was formerly professor of railway mechanical engineering in the University of Illinois, has been assigned by the War Department to the Fuel Administration, and the conference was called by him. Almost a year ago the International Railway Fuel Association appointed a committee which tendered its services to the government for the purpose of bringing about co-operation regarding the use of fuel by railways. The members of this committee participated in the conference with Major Schmidt. They include Eugene McAuliffe, chairman, formerly general coal agent of the Frisco system, who is now in the coal business; W. L. Robinson, Baltimore & Ohio; E. W. Pratt, Chicago & North Western; L. R. Pyle, Soo Line, and D. C. Buell, Railway Educational Bureau. Others who participated in the conference were M. K. Barnum, Baltimore & Ohio; John Crawford and A. W. Wilson, Burlington, and Charles Hall, Indiana Coal Operators' Association. It is an unsettled question whether the matter of fuel conservation on the railways will be handled by the Fuel Administration or under the Director General of Railroads.

Following the Chicago conference, the Executive Committee of the International Railway Fuel Association telegraphed the Fuel Administrator, tendering the services of the association, its members and its executive committee, to the conservation division of the Fuel Administration.

Second Tobacco Shipment to Railway Regiments

On February 23 the committee in charge of the Railway Regiments' Tobacco Fund forwarded its second shipment to the railroad regiments in France. The shipment consisted of 10 cases of 12 packages each. Each package contained 240 bags of Bull Durham smoking tobacco and 80 hags of Tuxedo pipe tobacco.

The tobacco is bought at wholesale prices and is not subject to revenue charges because it is consigned to government forces. It is delivered in bond to the Quartermaster's Department of the Army in this country, which takes care of its transportation without expense to the donors. The members of the committee in charge of the Tobacco Fund, of which F. A. Poor, president of the P. & M. Company, is chairman, themselves pay all of the office expenditures.

A letter received by Mr. Poor from Fred A. Preston, secretary and treasurer of the P. & M. Company, and now a

captain in the regular army in France, indicates to what an extent "smokes" are appreciated by the boys in France:

"The cigarettes arrived and I am the most grateful person in the world. Today for the first time in weeks I am having a real smoke. As I have told you before, I simply can't tell you how much smoking means to every one of us. There is something about the climate or the work that makes smoking absolutely indispensable. Whereas I formerly consumed about five a day, I now smoke 25, sometimes more, and because good cigarettes are not obtainable we smoke any d— thing."

Although a large number of supply companies have responded generously to the appeal for subscriptions, there is still a need for additional funds and contributions from other companies are solicited.

One contribution to the Railway Regiments' Tobacco Fund was received during the past month from the Empire Steel & Iron Company of Catasauqua, Pa., for \$20.

Backing Up the Boys at the Front

The following letter, which is self-explanatory, has been sent out to each of the more than seventy employes of the Seaboard Air Line shops and offices at Portsmouth, Va., who have joined the colors:

We, your fellow workers who are left behind, thinking you would like to hear from others than "Homefolks" back home, wishing to encourage you and at the same time to impress the fact that we are back of you to a man, have decided on what we think to be the most all around effective method. The Seaboard Air Line shop employes have gone together, as one man, in a society called the "Portsmouth Patriotic Society of Seaboard Shops."

The objects of this society are: To keep in touch with each of you who have enlisted in the nation's service, sending you periodically each month while the war lasts a shop letter telling you all the happenings of interest in Portsmouth, and following this, a small token of remembrance, such as tobacco, cigarettes, etc.; to keep in touch with your relatives back home, so that if ever at any time they are in need of any kind of help there will always be a willing helping hand to respond.

Now, this is our part—you will also have some duties to perform in connection with this society: Keep us posted as to your whereabouts as near as you possibly can. . . . as sometimes there may be some real good news to impart, and you will get it much quicker if we know exactly where to address you.

Your second duty is that, if there is ever anything we can do for you here, not to hesitate to call on us. Maybe there is something we can do in the way of keeping in touch with your relatives, and if so, the society, as one stanch friend, will consider it a privilege to help you.

Attached to this letter you will find a membership card, and you will note that your name is entered thereon as honorary member. Each one of us appreciates what you are doing, and considers this a privilege.

We have placed an honor board under "Old Glory" near entrance to the shops, and the name of each of you who have responded so readily to the call of our country is printed on it. We add new ones now and then, and the board is filling very quickly.

In closing we want to remind you to be on the lookout for a package which will follow the letter you receive from us each month. Hoping you will get encouragement and pleasure from being an honorary member of the Portsmouth Patriotic Society of Seaboard Shops, and wishing you lots of luck, we remain,
Your friends back home,
PORTSMOUTH PATRIOTIC SOCIETY.

MEETINGS AND CONVENTIONS

American Society for Testing Materials.—The twenty-first annual meeting of the American Society for Testing Materials will be held at the Hotel Traymore, Atlantic City, N. J., on June 25 to 28, 1918. Atlantic City was selected as the place for this meeting on the basis of the information received a year ago in reply to a detailed inquiry addressed to the membership which showed a decided preference for this city over others suggested. The annual meetings of this society have been held at Atlantic City for the past 16 years, with the single exception of that in 1903.

New York Railroad Club.—The next meeting, on March 15, 1918, will be the annual Electrical Night. The following is the program for the occasion, the subject being "Recent Electric Locomotives."

- The New York, New Haven & Hartford new 180-ton passenger locomotive, which will be presented by E. R. Hill.
- The Chicago, Milwaukee & St. Paul new gearless, bi-polar passenger locomotive under construction by the General Electric Company, which will be described by A. H. Armstrong, illustrated by lantern slides from photographs of the general drawings.
- The Chicago, Milwaukee & St. Paul new quill geared locomotive under construction by the Westinghouse Electric & Manufacturing Company, which will be described by F. H. Shepard of the Westinghouse Company and illustrated by lantern slides.
- The New York Central latest electric passenger locomotive which will be briefly described by Mr. Katté and illustrated with lantern slides.

The following list gives names of secretaries, dates of next or regular meetings and places of meeting of mechanical associations:

- AIR BRAKE ASSOCIATION.—F. M. Nellis, Room 3014, 165 Broadway, New York City. Convention May 7 to 10, 1918, Cleveland Ohio.
- AMERICAN RAILROAD MASTER TINNERS', COPPERSMITHS' AND PIPEFITTERS' ASSOCIATION.—O. E. Schlink, 485 W. Fifth St., Peru, Ind.
- AMERICAN RAILWAY MASTER MECHANICS' ASSOCIATION.—J. W. Taylor, Karpen Bldg., Chicago.
- AMERICAN RAILWAY TOOL FOREMEN'S ASSOCIATION.—R. D. Fletcher, Belt Railway, Chicago.
- AMERICAN SOCIETY FOR TESTING MATERIALS.—Prof. E. Marburg, University of Pennsylvania, Philadelphia, Pa. Annual meeting June 25-28, 1918, Hotel Traymore, Atlantic City, N. J.
- AMERICAN SOCIETY OF MECHANICAL ENGINEERS.—Calvin W. Rice, 29 W. Thirty-ninth St., New York.
- ASSOCIATION OF RAILWAY ELECTRICAL ENGINEERS.—Joseph A. Andreucetti, C. & N. W., Room 413, C. & N. W. Station, Chicago.
- CAR FOREMEN'S ASSOCIATION OF CHICAGO.—Arton Kline, 841 Lawlor Ave., Chicago. Second Monday in month, except June, July and August, Hotel Morrison, Chicago.
- CHIEF INTERCHANGE CAR INSPECTORS' AND CAR FOREMEN'S ASSOCIATION.—W. R. McMurry, New York Central, Albany, N. Y.
- INTERNATIONAL RAILROAD MASTER BLACKSMITHS' ASSOCIATION.—A. L. Woodworth, C. H. & D., Lima, Ohio.
- INTERNATIONAL RAILWAY FUEL ASSOCIATION.—J. G. Crawford, 547 W. Jackson Blvd., Chicago.
- INTERNATIONAL RAILWAY GENERAL FOREMEN'S ASSOCIATION.—William Hall, 1126 W. Broadway, Winona, Minn.
- MASTER BOILERMAKERS' ASSOCIATION.—Harry D. Vought, 95 Liberty St., New York.
- MASTER CAR BUILDERS' ASSOCIATION.—J. W. Taylor, Karpen Bldg., Chicago.
- MASTER CAR AND LOCOMOTIVE PAINTERS' ASSOCIATION OF U. S. AND CANADA.—A. P. Dane, B. & M., Reading, Mass.
- NIAGARA FRONTIER CAR MEN'S ASSOCIATION.—George A. J. Hochgrebe, 623 Eriehouse Bldg., Buffalo, N. Y. Meetings, third Wednesday in month, Statler Hotel, Buffalo, N. Y.
- RAILWAY STOREKEEPERS' ASSOCIATION.—J. P. Murphy, Box C, Collinwood, Ohio.
- TRAVELING ENGINEERS' ASSOCIATION.—W. O. Thompson, N. Y. C. R. R., Cleveland, Ohio. Next meeting, September 10, 1918, Chicago.

RAILROAD CLUB MEETINGS

Club	Next Meeting	Title of Paper	Author	Secretary	Address
Canadian	Mar. 12, 1918	Locomotive Repairs	E. R. Bately	James Powell	P. O. Box 7, St. Lambert, Que.
Central	Mar. 8, 1918	Terminal Handling of Locomotives; Annual Report of Committee on Interchange Rules	Frank C. Pickard	Harry D. Vought, H. Boutet	95 Liberty St., New York. 101 Carew Bldg., Cincinnati, Ohio.
Cincinnati	May 12, 1918	Reports, and Talk on War Conditions		W. E. Cade, Jr.	683 Atlantic Ave., Boston, Mass.
New England	Mar. 12, 1918	Annual Meeting, Election of Officers and Rules		Harry D. Vought	95 Liberty St., New York.
New York	Mar. 15, 1918	Annual Electrical Night		R. L. Kline	102 Penn. Station, Pittsburgh, Pa.
Pittsburgh	Mar. 22, 1918	Revision of M. C. B. Rules of Interchange		H. J. Pfeifer	102 Penn. Station, Pittsburgh, Pa.
St. Louis	Mar. 8, 1918	The St. Louis Terminals		Prof. G. A. Young	Union Station, St. Louis, Mo.
Western	Mar. 18, 1918	Ry. Problems Investigated at Purdue Univ.		Joseph W. Taylor	1112 Karpen Bldg., Chicago.

PERSONAL MENTION

GENERAL

H. T. BENTLEY, superintendent of motive power and machinery of the Chicago & North Western at Chicago, has been called to Washington, D. C., for an indefinite period to join the staff of the director-general of railroads.

F. F. GAINES, formerly superintendent motive power of the Central of Georgia, has been made a member of the staff of Regional Railroad Director C. H. Markham, at Atlanta, Georgia.

N. C. KIEFFER has been appointed fuel agent of the Southern Railway, lines west, with office at Cincinnati, Ohio, succeeding R. D. Quickel, entered military service.

T. D. SEDWICK, acting engineer of tests of the Chicago, Rock Island & Pacific, with headquarters at Chicago, Ill., was appointed engineer of tests, with the same headquarters.

F. O. WALSH, superintendent of motive power of the Georgia Railroad, has also been appointed superintendent of motive power and equipment of the Atlanta & West Point and the Western Railway of Alabama, at Montgomery, Ala.

MASTER MECHANICS AND ROAD FOREMEN OF ENGINES

FRANK AITKEN, master mechanic of the Pere Marquette at Wyoming (Grand Rapids), Mich., has been appointed master mechanic of the Chicago Great Western at Des Moines, Iowa, to succeed W. H. Erskine.

RAY AUSTIN, heretofore a locomotive engineman of the Chicago, Milwaukee & St. Paul, has been appointed traveling engineer of the Illinois division.

H. H. CARRICK, assistant master mechanic of the Southern Pacific at San Francisco, Cal., has been appointed master mechanic of the Stockton division, with headquarters at Stockton, Cal., succeeding F. P. McDonald, transferred.

W. C. DAVIS has been appointed road foreman of engines of the Shasta division of the Southern Pacific, with headquarters at Dunsmuir, Cal., succeeding R. W. CUVELLIER, assigned to other duties.

W. H. DEMPSEY, formerly a locomotive engineman of the Chicago, Milwaukee & St. Paul, has been made traveling engineer of the Chicago and Milwaukee division.

HENRY DERSCH, an engineman of the Chicago, Milwaukee & St. Paul, has been promoted to the position of traveling engineer of the Prairie du Chien and Mineral Point divisions.

W. H. ERSKINE, master mechanic of the Chicago Great Western, at Des Moines, Iowa, has been appointed master mechanic of the Virginian Railway.

J. F. GILDEA, division master mechanic of the Canadian Pacific, with office at Montreal, Que., has been appointed master mechanic of the Pennsylvania division of the Delaware & Hudson, with headquarters at Carlondale, Pa., succeeding J. J. Reid, resigned.

RALPH E. GRAVES, a locomotive engineman of the Chicago, Milwaukee & St. Paul, has been made traveling engineer of the Superior division.

F. B. HIGBEE, a locomotive engineman of the Chicago, Milwaukee & St. Paul, has been appointed traveling engineer of the Southern Minnesota division.

G. P. HODGES, general car and locomotive foreman of the Chicago, Milwaukee & St. Paul, with headquarters at Ma-

son City, Iowa, has been appointed division master mechanic of the Iowa and Dakota division, at the same point.

J. M. KERWIN, master mechanic of the Chicago, Rock Island & Pacific, with headquarters at Estherville, Iowa, has been transferred to newly opened headquarters at Silvis, Ill.

EDWARD M. LAKE has been appointed master mechanic of the Meridian & Memphis, with office at Meridian, Miss. He was born at Mobile, Ala., in 1870, and his first railroad experience was as a machinist apprentice with the Louisville & Nashville. He was afterward employed by the New Orleans & North Eastern as a machinist, and was subsequently appointed roadhouse foreman. He later went with the Gulf & Ship Island as master mechanic, and was latterly foreman of the New Orleans, Mobile & Chicago at Laurel, Miss.

B. A. LEMBEKE, formerly a locomotive engineman, has been promoted to traveling engineer of the Wisconsin Valley division of the Chicago, Milwaukee & St. Paul.

GEORGE H. LUSK, formerly a locomotive engineman of the Chicago, Milwaukee & St. Paul, has been appointed traveling engineer of the Iowa West and Des Moines division.

JOHN P. LUTZE, a locomotive engineman of the Chicago, Milwaukee & St. Paul, has been appointed traveling engineer of the Iowa East and Middle division.

A. M. MARTINSON, formerly a locomotive engineman of the Chicago, Milwaukee & St. Paul, has been appointed traveling engineer of the Racine & Southwestern, and Rochelle & Southern line.

C. H. McCURUM has been appointed traveling engineman of the Kansas City division of the Chicago, Milwaukee & St. Paul. He was formerly a locomotive engineman.

H. C. McCULLOUGH has been appointed road foreman of equipment of the Chicago, Rock Island & Pacific, with headquarters at El Reno, Okla.

R. J. McQUADE, general foreman of the locomotive department of the Chicago, Rock Island & Pacific at Chicago, has been appointed master mechanic to succeed J. M. Kerwin, with headquarters at Estherville, Iowa.

F. P. MILLER, general car and locomotive foreman of the Chicago, Milwaukee & St. Paul, at Marion, Iowa, has been appointed division master mechanic of the Iowa division, with the same headquarters.

W. P. MURPHY has been appointed road foreman of equipment of the Chicago, Rock Island & Pacific, with headquarters at El Reno, Okla.

GEORGE E. PASSAGE, a locomotive engineman of the Chicago, Milwaukee & St. Paul, has been promoted to traveling engineer of the Chicago terminals.

J. H. PHILLIPS, traveling engineer of the Chicago, Milwaukee & St. Paul, has been appointed division master mechanic of the Northern division, at Horicon, Wis.

CHARLES RAITT, general foreman of the car department of the Atchison, Topeka & Santa Fe, at Richmond, Cal., has been appointed master mechanic of the Arizona division, at Needles, Cal., succeeding L. A. Mattimore, deceased.

H. S. ROWLAND, formerly a locomotive engineman of the Chicago, Milwaukee & St. Paul, has been appointed traveling engineer of the Sioux City and Dakota division.

J. T. SLAVIN has been appointed assistant master mechanic of the Coast division of the Southern Pacific, with headquarters at San Francisco, Cal., succeeding H. H. Carrick.

W. B. STEEVES, locomotive foreman of the Canadian Northern, with headquarters at Saskatoon, Sask., has been promoted to assistant master mechanic of the western district, with headquarters at Edmonton, Alta.

R. R. STOCKWELL, formerly a locomotive engineman, has been appointed traveling engineer of the Dubuque division of the Chicago, Milwaukee & St. Paul.

E. M. SWEETMAN, master mechanic of the Southern Railway, with office at Spencer, N. C., has been transferred to the Coster shop, Knoxville, Tenn., as master mechanic, succeeding N. N. Boyden, resigned to go into other business.

J. C. WOODS has been appointed acting master mechanic of the Quincy, Omaha & Kansas City and the Iowa & St. Louis, with office at Milan, Mo., succeeding C. H. Montague, master mechanic, who has resigned.

CAR DEPARTMENT

E. B. COLTON, assistant car foreman of the Chicago & Eastern Illinois at Danville, Ill., has been appointed car foreman, succeeding C. E. Bumpus, promoted.

JOHN L. CONERLY, whose appointment as master car builder of the Missouri, Kansas & Texas, with headquarters at Denison, Texas, was announced in the January issue, was born in Pike county, Miss., on November 22, 1869. He entered the service of the Illinois Central in December, 1890, as car repairer at McComb, Miss., and was later promoted to inspector. On December 31, 1900, he was promoted to car foreman and transferred to Jackson, Miss., where he remained until June, 1903, when he was transferred to New Orleans, La. He remained at New Orleans until June, 1910, when he was promoted to general car foreman and transferred to Memphis, Tenn. He left the Illinois Central in February, 1914, to take a similar position with the Missouri, Kansas & Texas, at Denison, Texas, and in September, 1914, he was promoted to general car inspector. He was with the Ft. Worth & Denver City and the Midland Valley from September, 1915, to February 15, 1917. He returned to the Missouri, Kansas & Texas as general car inspector on February 15, 1917, and from this position was promoted to master car builder, effective January 1, 1918, succeeding H. J. Tierney, resigned.

E. H. MATINGLY, formerly car foreman of the Baltimore & Ohio at South Chicago, Ill., has been appointed joint general car foreman of the Chicago district of the Baltimore & Ohio and the Baltimore & Ohio Chicago Terminal Railroad.

F. C. RUDLOFF has been appointed foreman of the car department of the Missouri, Kansas & Texas at Denison, Texas, succeeding W. H. Macen, transferred.

A. G. SAUNDERS has been appointed master car repairer of the Tucson division of the Southern Pacific, with headquarters at Tucson, Ariz., succeeding E. M. Dickerman, resigned.

O. E. SHAW, general car foreman of the Chicago & Eastern Illinois at Danville, Ill., has resigned to take a position as master car builder of the Wilson Car Lines at Chicago.

J. M. WOOD has been appointed foreman of freight car repairs of the Georgia Southern & Florida at Macon, Ga., succeeding C. F. Roberts, resigned.

SHOP AND ENGINEHOUSE

H. W. BURKHEIMER, formerly assistant foreman of the roundhouse of the Southern Railway at Knoxville, Tenn., has been appointed night foreman of the roundhouse.

C. F. KARNS, a boilermaker in the Coster shops of the Southern Railway, at Knoxville, Tenn., has been appointed assistant boilermaker foreman.

J. A. MURRIAN has been made assistant foreman of the roundhouse of the Southern Railway at Knoxville, Tenn.

V. N. Potts has been appointed general foreman of the

locomotive department of the Chicago, Rock Island & Pacific, with headquarters at Liberal, Kan.

J. P. SPEARS, formerly night roundhouse foreman of the Southern Railway at Knoxville, Tenn., has been appointed general roundhouse foreman.

PURCHASING AND STOREKEEPING

W. E. ALLEN has been appointed purchasing agent of the Gulf, Florida & Alabama, with office at Pensacola, Fla.

J. A. BRACKETT, division storekeeper of the Atchison, Topeka & Santa Fe at Calwa, Cal., has been transferred to Bakersfield, Cal., succeeding W. H. Bunch, who has entered the National Army.

J. L. DISSL, division storekeeper of the Atchison, Topeka & Santa Fe, at Riverbank, Cal., has been transferred to Calwa, Cal., succeeding J. A. Brackett, transferred.

JAMES E. GARNETT, division storekeeper of the Southern Railway at Memphis, Tenn., has been appointed division storekeeper, with office at Sheffield, Ala., succeeding H. H. Delony, resigned to accept service elsewhere.

J. W. RIDDINGS has been appointed storekeeper of the Atchison, Topeka & Santa Fe at Richmond, Cal., succeeding H. I. Heath, who has entered the National Army.

M. VELASCO has been appointed local purchasing agent of the Constitutionalist Railways of Mexico, with office at New York, succeeding F. E. Carrero, resigned.

COMMISSION APPOINTMENT

HIRAM W. BELNAP has been appointed manager of the Safety Section of the Division of Transportation of the United States Railroad Administration. Mr. Belnap has



H. W. Belnap

been with the Interstate Commerce Commission for 15 years, for the past seven years as chief of the Bureau of Safety, and for the preceding eight years as inspector of safety appliances. Previous to that he had had 14 years' experience in various capacities in train operation. It is announced that, as manager of the Safety Section, "he will deal directly with each railroad, supervising such organizations for safety as are already available, bringing about

such uniformity in practice as is deemed necessary, and suggesting such additional organizations and such modifications of practice as are desired. . . . The director general feels strongly that there should be no abatement whatever in the safety work on the railroads, but that there should be centralized supervision, not only to insure proper practices, but also in order that each railroad may promptly secure the advantage of experience which other roads have had in the development of safety work." Mr. Belnap will continue to exercise his usual functions under the Interstate Commerce Commission.

OBITUARY

WILLIAM PERCY, for several years chief joint inspector at Los Angeles, Cal., died at Long Beach, Cal., on January 8, 1918.

SUPPLY TRADE NOTES

A. E. Crone has been elected vice-president and general manager of the Buffalo Brake Beam Company, New York.

The Schroeder Headlight Company, Inc., Evansville, Ind., has changed its name to the Schroeder Headlight & Generator Company.

L. A. Larsen, assistant to the president of the Lima Locomotive Works, Inc., has since February 13 also been secretary-treasurer, succeeding Mr. Cloos, resigned.

The Asbestos Protected Metal Company, Pittsburgh, Pa., announces the removal of its Boston office to the State Mutual building. The office will be in charge of W. H. Cummings.

C. H. Wilson, southwestern railroad representative for Fairbanks, Morse & Co., has been appointed first lieutenant in the Engineers' Reserve Corps and has been assigned to active duty.

J. A. McNulty, roundhouse foreman of the Chicago & North Western, at Chicago, has entered the railway sales department of the Anchor Packing Company, with headquarters at Chicago.

The Barco Manufacturing Company, successors to the Barco Brass & Joint Company, Chicago, has recently appointed the Holden Company, Ltd., of Montreal, as its exclusive Canadian agents.

The Westinghouse Electric & Manufacturing Company announces the removal of its office from Phoenix, Ariz., to Tucson, Ariz. Its representatives, J. H. Knost and W. G. Willson, will have headquarters in the Immigration building at the latter point.

W. S. King, formerly general superintendent of the Illinois Central, has entered the supply field, with offices in the McCormick building, 352 South Michigan avenue, Chicago. He will represent the Damascus Brake Beam Company and the Frost Railway Supply Company, and will also handle general railway supplies.

P. K. Aldrich, formerly with Edwin S. Woods & Co., Chicago, has formed the Superior Side Bearing Company, with offices at 922 Webster building, Chicago. Mr. Aldrich is president and general manager of the new company, which will manufacture side bearings with an intermediate support, and other railroad specialties.

J. B. Henry, general superintendent of the Union Steel Casting Company, Pittsburgh, has been elected vice-president, to succeed J. P. Allen, recently elected president of the company. Mr. Henry will continue to discharge the duties of general superintendent, as heretofore. W. C. Eichenlaub, secretary, has also been appointed manager of sales.

The L. S. Brach Supply Company, Newark, N. J., announces the following appointments: as superintendent, Henry Keohler, formerly of the Crucible Steel Company; as production engineers, Louis Rist, formerly with the Crocker-Wheeler Company, Ampere, N. J., and Herman Rose, formerly a foreman with the L. S. Brach Supply Company.

E. A. Simmons, president of the Simmons-Boardman Publishing Company, publishers of the *Railway Age*, *Railway Mechanical Engineer*, and other railway periodicals, and also president of the American Saw Mill Machinery Company, the American Tool Company and the American Saw Works, all of Hackettstown, N. J., has been commissioned a major in the Quartermaster Corps, National Army, reporting to the cantonment division at Washington.

The Walter A. Zelnicker Supply Company, St. Louis, has established permanent offices at Minneapolis, Minn., 627 Plymouth building, to serve the north central and Canadian trade. Richard K. Papin, formerly St. Louis and southwestern representative of the Davenport Locomotive Works and for ten years manager of the Zelnicker Company's equipment department, is in charge.

W. N. Thornburgh, vice-president and general manager of the Harrison Railway Specialties Company, Sandusky, O., will devote his entire time to his duties as president and treasurer of the William N. Thornburgh Company, manufacturers of the "National" steel and wood dust guard, and purchasers and sellers of used rails, cars and locomotives. He will have headquarters in Chicago, as heretofore.

B. S. Smith has been appointed circulation manager of the Simmons-Boardman Publishing Company, succeeding W. D. Horton, who has resigned to enter the sales department of the Patton Paint Company, Milwaukee, Wis. Mr. Smith has been employed as a subscription solicitor for the Railway Age, the *Railway Mechanical Engineer* and other Simmons-Boardman publications since October 1914. He enters upon his new duties, effective March 1.

H. S. Cooper, vice-president of the Independent Pneumatic Tool Company, manufacturers of pneumatic tools and electric drills, who for many years was the manager of the company's eastern branch in New York City, on February 1 assumed the duties of general sales manager as well as those of vice-president. His headquarters are at the general offices of the company, Thor building, Chicago. R. T. Scott, the former Pittsburgh branch office manager, has been promoted to the office of eastern manager, with headquarters at 170 Broadway, New York. H. F. Finney, who formerly traveled the Chicago and St. Louis territories, has been placed in charge of the company's branch office at Pittsburgh, Pa.

T. McCullum, formerly roundhouse foreman for the Duluth, Missabe & Northern, has been appointed railway representative for the Garratt-Callahan Company, Chicago, in charge of the northwest territory, with headquarters in Minneapolis, Minn. William Rollinson, foreman in the mechanical department of the Minneapolis, St. Paul & Sault Ste. Marie, has been appointed railroad representative in the states of Ohio, Indiana and Illinois, with headquarters at Indianapolis, Ind. George DuR. Fairleigh, formerly in the sales department of the U. S. East Iron Pipe Company, has been appointed railroad representative in the southwestern territory, with headquarters at Dallas, Tex. G. E. Wilson, formerly master mechanic for the Nevada Consolidated Copper Company, operating the Nevada Northern, has been appointed railway representative for the Pacific Coast territory, and will have his headquarters at San Francisco, Cal.

Goldschmidt Metal and Chemical Interests Combine

The business of both the Goldschmidt Detinning Company and the Goldschmidt Thermit Company will hereafter be conducted by the Metal & Thermit Corporation, with general offices at 120 Broadway, New York. These two concerns have been practically combined for the last two years and have occupied joint offices at the above address. The combination, which is controlled exclusively by Americans, has now been put in more permanent form, as it is felt that this will tend toward greater efficiency and co-ordination of effort.

The detinning department of the Metal & Thermit Corporation will carry on one of the largest industries of its kind in the world, i. e., the recovering of tin from tin scrap. Approximately 100,000 tons of tin scrap is treated yearly by this department and the recovery approximates the equivalent of 2,000 gross tons of metallic tin. The output of this branch

of the corporation consists of pig tin of a quality equalling Straits tin, tetrachloride of tin and detinned billets, the latter being the iron scrap after the tin is removed, which is compressed into billets and is used by iron and steel plants for remelting.

The Thermit welding process is used by practically all the railroads in the United States and Canada for welding broken locomotive frames and other heavy sections. It is also used very extensively by steel mills for welding broken equipment. Over 1,000,000 lb. of Thermit is used annually by these two industries alone. The Metal & Thermit Corporation operates four different plants, located respectively in Jersey City, Chrome, N. J.; Wyandotte, Mich., and East Chicago, Ind. The Chrome and East Chicago plants are devoted to the detinning industry; the Wyandotte plant to the production of liquid chlorine and the Jersey City plant to the Thermit products, including welding materials, carbon-free metals and alloys and pure Tungsten powder. The corporation operates branch offices and welding shops in Pittsburgh, Chicago, San Francisco and Toronto.

Chicago Railway Equipment Company Celebrates Its Twenty-fifth Anniversary

The Chicago Railway Equipment Company celebrated its "Silver" anniversary on the evening of February 5 at the Union League Club, Chicago. It was the twenty-fifth consecutive annual dinner held around the same table and in the same room. The participants included members of the organization, directors, shareholders and guests.

President E. B. Leigh, reviewing the progress of the company, said that in the quarter century the floor space devoted to the business of the company had increased from 30,000 sq. ft. to over 800,000 sq. ft., the total land owned to about 60 acres and the number of plants from one to five, located at Chicago, Detroit, Grand Rapids, Mich., Monon, Ind., and Franklin, Pa. Founded originally upon its brake beam business, the company had so far diversified its products that now about 70 per cent is sold to customers other than the railroads.

Mr. Leigh also told how the company had started with the original "Hein" (National Hollow) brake beam, and how at the expiration of the foundation patents fifteen years later it had in turn brought on the market the "Creco" brake beam. How effectively this worked out, he added, was "evidenced by the fact that so far as known not a single National Hollow brake beam has ever been manufactured or sold by any other than your own company."

The matter of standardization was commented on by Frank W. Noxon, secretary of the Railway Business Association, one of the guests.

In his remarks Mr. Noxon said:

"We have before us, when peace shall come, the project of reconstituting our whole railway system, in some way yet to be thought out, and to be debated out. We have a very animated, a very active, thorough-going propaganda, which has for its purpose to place all of the transportation agencies in the hands of the government. Of course, one of the first things that would result from that would be that the provision of appliances, the provision of rolling stock, and of tracks, of signals, and all those things would be centralized in the hands of some governmental agency.

"I have been wondering how, under such a system, it would be possible for a series of events to occur, such as we heard recorded to-night in these reports; how the event, which I noticed particularly, when at one stage a patent was about to run out, and when the inventive geniuses of the institution were set to work to provide an improvement over the old device—how such an event could come about.

"Naturally, if the government were to have in its hands

the matter of developing the equipment, the men who now and in years past have devoted themselves to improvements in competition one with another, first asking the consideration of one railroad, and then finding that railroad indifferent, going to another, and so on until some hospitable mind was found—instead of that the purveyor or developer or inventor goes to some central board not composed of men who have direct personal interest at stake in proving their hospitality toward the new, but men perhaps overburdened with detail, tempted to standardize and overstandardize—and a deaf ear is turned, perhaps. Suppose it is—there is no recourse, there is no appeal. The improvement projected in the mind of the inventive genius is stopped, then and there.

"I question if men of the calibre of the men who have made this company what it is would be attracted to go in or stay in a business where the opportunity was in the hands, as it would be, of a government board.

"I just want to ask you to think of the great advantages, if we can have it, of maintaining some degree of decentralization, in the future, in the development of railway equipment.

"I think we all feel quite open-minded toward substantial changes from what has been in the past. We expect that what we have learned in the war will teach us things that we must apply and embody in a new system; and the question is whether or not we may have, when it is all over, sufficient decentralization so that the plans and schemes for the improvement of railroads may proceed from below, from the railroad managers themselves, and not from some bureau, static and stagnant, so that business men and inventors, men of imagination, will be attracted into that business, and the American people and the whole world have the benefit of rapid rather than slow progress."

Franklin Railway Supply Company of Canada, Ltd.

The Franklin Railway Supply Company of Canada, Limited, has taken over the business formerly handled by the Montreal branch of the Franklin Railway Supply Company, Inc. The new company will have exclusive rights in Canada to all the products of its parent company and will continue the same policies and business methods that have governed the Franklin Railway Supply Company, Inc., since its formation. The officers of the new company are: J. S. Coffin, chairman of the board; Joel S. Coffin, Jr., president, and Leland Brooks, vice-president. The company's headquarters will be at Montreal.

Joel S. Coffin, Jr., who has been elected president of the new company, brings to this new organization a wide experience in both the railroad supply business and locomotive building. He was born at Waukesha, Wis., and received his education at the public schools in Franklin, Pa., and Stevens Institute. After leaving Stevens he entered the service of the Venango Manufacturing Company at Franklin, Pa., and later served the American Locomotive Company in the erecting shop and as locomotive inspector. In 1912 he entered the employ of the Franklin Railway Supply Company as a service representative. He later went into the sales department and in 1915 was appointed Canadian sales manager which position he held up to the time of his recent election to the presidency of the Canadian corporation.

Leland Brooks, who has been elected vice-president of the Franklin Railway Supply Company of Canada, Ltd., was born at New York City and received his education in the public schools of that city and Stevens Institute. Upon leaving Stevens he entered the employ of the New York Central, serving seven years in the engineering department. Leaving the New York Central he took a position with the Franklin Railway Supply Company, Inc. For the past year he has been connected with its Canadian branch as assistant manager, which position he held up to the time of his recent election.

Railway Mechanical Engineer

Volume 92

April, 1918

No. 4

CONTENTS

EDITORIALS:

Selling Bonds to Ready Buyers.....	183
Equipping Foreign Cars with Safety Appliances.....	183
Competent and Adequate Shop Supervision.....	184
An Economy Clause in Locomotive Specifications.....	184
Should a "Run, Repair or Transfer" Rule Be Adopted?.....	184
United States Standard Cars.....	184
The Transfer of Locomotives.....	185
The Railways Lack Proper Repair Facilities.....	185
The Question of Standard Locomotives.....	186

GENERAL:

Intensive Locomotive Development.....	187
The United States Standard Cars.....	189
Machine Tool Equipment Needed.....	209
Organization Maintenance.....	210
Freight Car and Tender Truck Bolsters.....	211
A New Sprinkler Arrangement.....	216
Back Up the Boys at the Front by Work.....	216

SHOP PRACTICE:

Firbox Repairs.....	217
Close Quarter Drive and Old Man.....	218

Shop Scheduling on the B. R. & P.....	219
Labor Saving Devices on the Southern.....	221
Two Valuable Hoist Devices.....	222
How Jack Wingate Secured a Raise.....	223
Device for Removing Gaskets from Sight Feed Lubricators.....	224
Reclaiming High Speed Steel.....	225
Miscellaneous Equipment at the Shoreham Shops.....	227
Throttle Safety Appliance.....	228

NEW DEVICES:

A New Axle Lathe.....	229
Feedwater Treatment.....	230
Boiler Brace Coupling.....	231
Air Valve Lift Gage for Cross Compound and Single Stage Steam Driven Air Compressors.....	231
Portable Electric Drill and Grinder.....	232
Balancing Stand.....	232

GENERAL NEWS:

Notes.....	233
Meetings and Conventions.....	235
Personal Mention.....	235
Supply Trade Notes.....	237
Catalogues.....	240

**Selling
Bonds to
Ready Buyers**

By the time this will have appeared in print the Third Liberty Loan Campaign will be well under way, following its auspicious launching Saturday, April 6, on the anniversary of the entrance of the United States into the great world war. In this campaign the railwaymen who subscribed for 20 million in bonds in the first campaign and 36 million in the second are expected quickly to exceed their former total. Three committees of railroad presidents have been formed—one for each regional district—and every railroad man from the head office down is expected to do his share. The mechanical department officers, particularly, have a clearly defined work to do in the campaign, and in many ways they have a compensating advantage that officers in some of the other departments do not have, for their men are together and can be easily reached. What is this work that every mechanical department officer should take advantage of this opportunity to do? (1) To subscribe himself until it hurts; (2) to hold shop meetings to advertise to the men the necessity of subscribing; (3) to solicit the men personally in so far as possible to get their names on the subscription blank dotted line and (4) to lose no chance to push home the seriousness of the war to the remaining few who do not understand what America stands for in this conflict. It is somewhat difficult to believe that there are any Americans left who do not realize what our being in the war means and it is equally hard to believe that there are still Americans who do not understand the sterling worth of Liberty Bonds or realize the unsurpassed opportunity they offer to save money for oneself and help the gov-

ernment. In short, in most cases, it is only a case of clinching the selling argument. Let us see now what success the mechanical department will have in helping railroad men beat easily their totals in the other two campaigns!

**Equipping Foreign
Cars With Safety
Appliances**

The date set for the completion of the work of equipping cars with safety appliances, as required by law, has recently been extended to September 1, 1919. Energetic measures will be needed to finish the work within the time allowed. Reports recently submitted by the railroads show that on October 1, 1917, out of 2,572,363 cars owned by the roads, there remained to be equipped 181,611 cars, or more than 7 per cent of the total number owned. On some roads more than 60 per cent of the cars are still without the required safety appliances; on other roads less than 1 per cent require this work to be done.

The experience of the roads has shown that as the percentage of cars equipped increased it became difficult to find cars without safety appliances that could be brought to the repair track, and consequently toward the end the work progressed quite slowly. The roads have almost without exception equipped only their own cars. The removal of the restrictions regarding the movement of cars has resulted in a much smaller proportion of equipment remaining on the home lines than was formerly the case, and has also increased the length of time the equipment stays off the home road. It is evident that the work cannot be completed within the time allowed unless it is done on foreign lines as well as on the home road.

The roads should make arrangements at all repair points to take care of any cars requiring safety appliances that come on the repair track, whether home or foreign. As practically all the cars built before the safety appliance law went into effect were wooden cars, the work can usually

be done even where the facilities for steel car work are poor. In applying the grab irons and sill steps, any arrangement that meets the requirements of the Interstate Commerce Commission may be applied.

Competent and Adequate Shop Supervision Statements have been made to the effect that it is exceedingly difficult to retain or obtain men in the capacity of foremen. With the increase in the labor turnover and the decrease in the efficiency of labor, a sufficient number of competent foremen is more than ordinarily necessary at this time. In most such cases much sympathy cannot be given to the complaining roads. The salaries of the supervising officers and foremen have in a large number of cases not kept pace with the increases in wages to the workmen. When a man in the capacity of a foreman gets less than some of the men under him, it is but natural that he should complain and accept positions paying more or even prefer to return to the ranks. It is a serious problem and should be given careful consideration by every mechanical department organization. The railroads need now as never before competent and active foremen if shop production is to be maintained and brought up to a point which will bring the locomotives back into proper condition. It is expected that such conditions will be improved with the report of the Railroad Wage Commission and those foremen who are dissatisfied with their existing conditions should wait for this report before making any changes.

An Economy Clause in Locomotive Specifications In the concluding part of the article on Intensive Locomotive Development, which will be found on another page of this issue, the author says: "It is an astonishing situation that the railway industry has not long ago established the practice of calling for certain guaranteed economical performances of new locomotives or even locomotive devices and of running a series of performances or acceptance tests to see whether or not these guarantees are being met." While we cannot altogether agree with the author that the failure to demand guaranteed economy of performance is to be wondered at, we do heartily agree that such a practice is highly desirable and that this is a good time to begin to prepare for its ultimate establishment.

That the economy of motive power performance has not been given the attention in the railroad field which it has received in other industries is probably owing to the fact that motive power development has been in the direction of constantly increasing capacity, because train loading has a more direct and more tangible bearing on ton-mile costs than the horsepower-hour economy of the locomotive. Then there are other conditions, such as the extent of the standby losses, which have an important bearing on the cost of coal on a ton-mile basis and that are beyond the control of the locomotive designer. With the rising cost of coal and, what is of greater importance, the growing economic value of coal, the need of highly economical performance is becoming so great that it must receive much more attention than has been given to it in the past. At present it is doubtful if there is a builder in the country, perhaps not even a designer, who could intelligently meet a coal economy guarantee if one were inserted in the specifications. There is available too little exact knowledge of the effect on economy of variations in locomotive proportions.

It is becoming evident that limits of size and weight are rapidly being reached which preclude further extensive capacity increases in that direction. Further development must, therefore, be along the lines of increased economy of operation, both for its own sake and for the sake of increases in capacity. So surer foundation for the structure of such improvements can be provided than that suggested by the author of the article referred to above.

Should a "Run, Repair or Transfer" Rule Be Adopted?

Since the railroads have been under Government control it has been suggested repeatedly that the adoption of a rule requiring the receiving line to run, repair or transfer, at its own expense, cars offered to it by connecting lines, would expedite the movement of cars and have a favorable effect on operating conditions. The principal advantage which those who advocate the adoption of this rule claim for it, is a marked reduction in the number of cars transferred at interchange points.

Years ago, before the interchange of cars had been developed to the point it has now reached, the "run, repair or transfer" rule was in effect. It became apparent that this rule worked a hardship on the lines with heavy motive power and favored those with light equipment. In order to overcome this, the delivering line has been made responsible for the cost of transfer when necessary on account of defective equipment or improper loading, according to A. R. A. car service rule 15. The defects which must be repaired while the car is under load are specified in M. C. B. Rule 2, so the receiving line cannot transfer the load unless it is necessary. If cars are being transferred unnecessarily, the remedy lies not in changed rules, but in closer supervision.

There are numerous disadvantages that would result from the adoption of the run, repair or transfer rule at this time. The most important is that it would tend to make the originating line indifferent as to the condition of the equipment loaded. A large amount of freight originates on branch lines, where the trains are short and the motive power is light. A car with part of the draft bolts broken or missing may not cause trouble on such a road. To try to operate such a car in a long train would probably cause a break-in-two. If the delivering line is not held responsible for the cost of transferring the lading, it will merely maintain the cars in such condition that they will be fit to pass over its own lines, and the receiving roads, if their operating conditions require better equipment, will have to transfer far more cars than they do under the present arrangement. The effect that this would have on the already overburdened trunk lines can readily be seen. The roads are having trouble now because the shippers load equipment that is not fit to operate.

United States Standard Cars

The Railroad Administration has during the past month issued specifications and drawings showing the designs of the standard cars on which a committee has been working during the past two months. Designs have been made for the bodies of a 40- and 50-ton steel frame, single sheathed box car; a 40-ton steel underframe, double sheathed box car; a 50-ton high side steel gondola, a 50-ton high side composite gondola; a 70-ton low side steel gondola; a 55-ton hopper car and a 70-ton hopper car. Three designs of trucks having capacities of 40 tons, 50 tons and 70 tons have been provided to use on the standard car bodies. These cars have been designed to have adequate strength and sufficient interchangeability, so that repairs may be easily made and the amount of material to be carried in stock at both the builders' plants and on the railroads may be kept to a minimum. A study of the drawings, which are shown elsewhere in this issue, will show the extent to which the material of which these cars are made is interchangeable. Of special interest is the extent to which pressed steel parts have been used in an endeavor to reduce the requirements of the structural steel shapes. While structural steel shapes have been used, the number of sections involved in the designs is small. This will permit of buying such material in large quantities for the various designs on which it is to be used.

The Railroad Administration has been broad in the matter of the specialties to be used. The draft sills have

been arranged to take the Cardwell, Murray, Sessions type "K," Westinghouse and Miner draft gears, provided they come within the limiting dimensions specified in the specifications. An outside all-steel roof is to be used, either of the Murphy, Hutchins or Chicago-Cleveland type. Steel ends are specified of either the Murphy, vertical corrugated or plain steel ends. The M. C. B. standards have been used to a large extent, including the type "D" coupler and the No. 2 and No. 3 brake beams. The truck sides permit of using the arch bar for the 40- and 50-ton and cast steel for all truck capacities. The latter, however, must be of U-section and meet certain specifications for strength. In all cases limiting dimensions are provided, so that where specialties are used, they must be made to fit these dimensions. This simplifies the repair problem to a large extent. Inquiries for 100,000 of these cars have been made by the Government, and the prices of the builders have, it is understood, been submitted. The supply men have also been interviewed by the purchasing department of the Railroad Administration and bids asked for the various parts which they are able to furnish.

The Transfer of Locomotives

The extraordinary traffic congestion which began seriously to cripple several of the eastern roads at the beginning of last winter, made it essential that more motive power be obtained from any available source for use on these lines. The borrowing of locomotives from some of the less congested western lines was resorted to in the emergency and the practice has been extended until at the present time there are probably at least 600 foreign locomotives in operation on various railroads in the eastern and southeastern sections of the country. These locomotives were obtained partly from other railroads, partly by diverting new locomotives as they were delivered from the builders, and partly by the use of United States Army and Russian Decapod locomotives made available by the United States government. While this method of relieving a very serious situation was wholly justified, there is now evident a tendency to carry the practice of shifting locomotives from road to road to extremes which must result in considerable confusion and loss of efficient service. Locomotives of one road are being scattered about among several other railroads, and on the other hand the roads borrowing locomotives, instead of receiving all of their power from one or two lending roads, are getting a miscellaneous collection of one or two locomotives each from several different lines. This situation no doubt has been the result of a lack of competent supervision of the details of the practice, if indeed any attempt has been made at co-ordination.

There are at least three fundamental considerations which should receive attention when such transfer is contemplated. First, the locomotives should be kept as near the owning road as possible, preferably on a division of a connecting line adjoining the owning road. Second, all of the locomotives borrowed from any one railroad should be kept together if the exigencies of the demand for power will permit, and each borrowing road should be furnished with the locomotives from as few other lines as possible. Third, more careful attention should be given to clearance limitations than apparently has been done in some of the transfers which have been made. Attention to the first two considerations will materially reduce the confusion and delays arising in the effort to secure a reasonable stock of repair parts for the borrowed locomotives. It will be much simpler for a railroad to protect its borrowed locomotives if they are all of one class, or at least all have come from one line, than if each one is different from the others. Furthermore, the drain upon the store stock of the loaning railroad will be re-

duced and its locomotives will be better maintained if they are kept together when away from home.

If these fundamentals are to receive the consideration which they deserve the whole practice of transferring locomotives must be placed under the supervision of one central agency. The agency to which it most logically belongs is the Locomotive Section of the Federal Railroad Administration. In the office of the manager of this section is available much of the information required for a co-ordinated handling of the transfers and his organization is in a position to secure such other information as may be necessary. Only through such handling of the matter can the present confusing situation be straightened out and worse confusion avoided in the future. At most the practice of shifting locomotives from one road to another is but an emergency measure and it is highly desirable that the locomotives be returned to the owning roads at the earliest possible moment.

The Railways Lack Proper Repair Facilities

One of the contributing causes to the great lack of sufficient motive power during the past winter was the inadequate and insufficient repair facilities. Locomotives cannot be expected to run indefinitely without repairs and repairs cannot be made without proper repair facilities. There is not a motive power officer in the country but will say, "Give me better and more shops in which to repair my locomotives and you will not need to buy so many new ones." One road owning over 2,000 locomotives estimates that over \$10,000,000 should be spent to bring its repair facilities up to the point where it can properly maintain them. Another road owning about 1,500 locomotives has a capacity for repairing only 750. Some of the best roads in the country are crying for additional shop capacity. It is the question of the hour in both the mechanical and engineering departments of the railroads. The need for new and improved shops should be driven home to the director general with sledge hammer blows. The Railroad Administration must be made to realize that with all the cars and locomotives it is considering purchasing, it must provide means for properly maintaining them.

It has been said that Mr. McManamy as manager of the Locomotive Section, in charge of locomotive repairs, has one of the biggest jobs on the Railroad Administration Board, but he says, "We have the biggest job to do"—and "We" it is, for he can not get results without the hearty co-operation from every mechanical department man in the country. The output of the shops must be increased by working longer hours, and in some cases roads have brought their hours up to 70 per week, in accordance with the suggestion of Mr. McManamy. That the output of shops has materially increased is shown from a report of 101 of the principal roads of the country, which in February, 1917, repaired 6,824 locomotives. In February of this year 8,390 locomotives were repaired, or an increase of 1,566. While this does not accurately represent the increase in production because of the different classifications used in the different shops, it does represent the actual increase of locomotives which were repaired and put in service.

Upon the shop forces rests to a very large extent the responsibility of adequate locomotive equipment for the railways this year and particularly for next winter. A road which is perhaps very well equipped with shop facilities must not ease up on locomotive repairs simply because its power is in good shape. It must be willing and ready, by working longer hours,—and it is here that labor can show its patriotism—to assist other roads which are not in such good condition to repair their locomotives until their facilities have been improved so they can handle their own work. Transferring locomotives to other shops for re-

pairs has been done to some extent since the government took control of the railroads. About 300 have been thus transferred of which about 60 have been handled by the locomotive builders.

This practice can only be considered as a temporary expedient, to be followed until such time as those roads with the poorer shop facilities get their power into such shape and their facilities so improved that they are able to handle their locomotives in their own shops. The transferring of locomotives from one road to the shop of another road not only takes time in making the transfer, but also increases the time in which the repairs are made and the cost of the repairs. It is the plan of Mr. McManamy to so assign locomotives to foreign roads for repairs that they will not have to be sent too far away from their home lines and to concentrate the repairs of a road at one shop so that the men becoming familiar with the locomotives may repair them more promptly. Where locomotives are being sent away for repairs, it is very necessary that a careful inspection be made before they are sent. Instances have been found where repairs other than those reported were necessary and the material for which had not been forwarded with the locomotive, causing a delay of some 10 days or two weeks.

being of a new design, will not be common to any road and will cause considerable trouble when repairs are to be made.

There are two sides from which such a problem as this should be considered, the railroads' side and the builders' side. The effect the introduction of the standard locomotive would have on any road is fully appreciated by the readers of this paper. It will be unnecessary to enumerate in detail just what the difficulties will be, as they are fully understood by the practical railroad men. Suffice it to say, however, the standard locomotives being of a compromise design and not being adapted to any one particular set of conditions, the efficiency of train operation will be reduced. There are so many conditions, such as grades, curvature, class of traffic handled, the coal used, water conditions, etc., that enter into the problem of locomotive design, that where these are all averaged in a compromise design, as good results cannot be obtained as where locomotives are constructed specifically to meet these conditions.

The question of the difficulty of making repairs to the standard locomotives will be appreciated by our readers. New patterns, dies, templates, etc., will be required with which to make the repair parts. There will be many details in the construction of the standard locomotives which will be entirely different from those in vogue on the roads on which these locomotives will be used. This will create confusion, and make the repairs more costly both in money and in time. New facilities will have to be created for making the repairs to heavier locomotives than the roads, in many cases, have been accustomed to handling in their repair shops. The repair situation is extremely critical as it is, and it would be inexpedient further to complicate it.

From the builders' standpoint it has been argued by some that the locomotives can be built cheaper and more rapidly if they are standardized. The saving in first cost is open to serious question. For instance, take the Mikado type locomotives purchased during the past year. Three hundred and sixty-seven were of weights lower than the weight of the standard Mikado being considered. By adding to the weight of these 367 locomotives, it has been found that about 10,000,000 more pounds of iron and steel will be required to meet these requirements with the standard locomotives. At 15 cents per pound for locomotives, this means an increase in the first cost for these 367 locomotives of \$1,500,000. The same argument will apply to all of the other types and it is safe to say that many thousand tons of metal will be used unnecessarily and that the locomotives will cost many millions of dollars more than if they were built to meet the specific requirements of the roads. Thus the saving in first cost is open to serious question, no matter how far the government may force down the prices of both the locomotives and the specialties used on them.

In regard to the increased output, it has been stated by those who are in a position to know, that after the first of April every day's delay in ordering locomotives will mean that the country will lose ten locomotives in production. This is caused by the fact that some of the locomotive builders have open space in June and July, which it will be impossible to fill, even if orders are placed at this time. The delay, therefore, occasioned by the development of standards for the locomotives is causing a decrease in our yearly production. It cannot be said at the same time that this delay is unnecessary. It is impossible to perform successfully such a gigantic task as the Railroad Administration has set for the Locomotive Standards Committee in the space of one month, or even two months. The question is of such vital importance to all the railroads of this country that a much longer time should be taken.

If the roads were permitted to buy locomotives which suit their needs and which they are organized to repair, far better results will be obtained and locomotives could be produced without delay.

The Question of Standard Locomotives

The work being done by the Railroad Administration's committee on the development of standard locomotives is of vital importance to every railway mechanical department officer and foreman. A careful study of the situation indicates that there is no justification for the railroads of this country being asked to operate locomotives which at best can be only of a compromise design and which in the long run will be unsuited to the peculiar operating conditions of each road; moreover the roads will not be properly equipped to repair them. There is no class of railroad men that knows better the impracticability of such a scheme than the men in the mechanical department. It is the duty of every such man to thoroughly consider the situation and present his arguments to his immediate superiors. It is also the duty of the head of every mechanical department to advise his Regional Director exactly what the standard locomotives will mean to him on his road. We must all be patriotic citizens and do our utmost to help this country win the war. Every man must be a "good soldier" and do as he is told, but a man would be derelict in his duty if he did not do his utmost to prevent our country from making a mistake which would interfere with the rapid and successful prosecution of the war. It is up to every railroad mechanical man in the country to give his honest and unbiased opinion through the proper sources and in the most direct channel in order to reach the Director General.

From what is known of the Railroad Administration's plans, standard locomotives are being considered of the Mikado, Pacific, Mountain, Santa Fe, Switcher and Mallet types. Two designs of the first four types are to be built, each having 55,000 and 60,000-lb. axle load. It is believed that an 0-6-0 switcher and an 0-8-0 switcher, a 2-6-6-2 and a 2-8-8-2 type of Mallet, all with 55,000-lb. axle load, are being considered. The Mikado, Pacific and Mountain types will have the following dimensions:

Type	Cylinders	Weight on drivers	tractive effort
Mikado	26 in. by 30 in.	220,000 lb.	54,600 lb.
Mikado	27 in. by 32 in.	240,000 lb.	60,000 lb.
Pacific	25 in. by 28 in.	165,000 lb.	40,700 lb.
Pacific	27 in. by 28 in.	180,000 lb.	43,800 lb.
Mountain	27 in. by 30 in.	240,000 lb.	57,000 lb.
Mountain	27 in. by 30 in.	220,000 lb.	53,900 lb.

While it is undoubtedly possible to use these locomotives economically on some roads of the country, it is an indisputable fact that there are many requirements which will not be met by them. In addition to this, these locomotives

INTENSIVE LOCOMOTIVE DEVELOPMENT

Why Not Require Guaranteed Minimum Economy of Performance and Check with Acceptance Tests?

BY CAPT. O. S. BEYER, JR.*

PART II

STEAM UTILIZATION

UNDER this heading there are several problems which deserve attention. It is perhaps in this department more than in any other that most has been accomplished in recent years. This has resulted from the perfection of the superheater. But the field is by no means exhausted.

Further Study of the Superheater.—In the first place, the superheater itself deserves further investigation. The work done at Purdue, and especially that at Altoona with varying numbers, lengths and diameters of superheater units has certainly contributed most valuable knowledge to this subject. As a continuation of this work, the correlation between degree of superheat and boiler pressure as reflected in the steam economy of the engines should be worked out over wider ranges and mathematical determinations verified.

Another very important question coming within this field is the effect of varying degrees of moisture in steam on superheat. Some recent tests have confirmed the fact that, when the large modern locomotive boiler works at high capacities, the steam entering the throttle contains much more moisture than when working at light capacities. Apparently a distinct relation exists between rate of evaporation and dryness of steam in the dome. This condition has its own distinct effects on the performance of the superheater. Hence it becomes very desirable to investigate this matter thoroughly. How best to deal with this condition, whether by means of a special type of separator, modified dome construction and throttle valve, or other means, will then follow logically.

Compounding of Steam Cylinders.—The possibilities of compounding the steam cylinders jointly with the use of superheated steam deserves more attention from the investigator's standpoint than it seems to be getting. The improvements in the manufacture and handling of heat treated and alloy steels, together with the increasing construction difficulties arising in the counterbalancing of heavy locomotives, to say nothing about the dawning knowledge of the extent of stresses in rails for which certain features of the steam locomotive are responsible, all make this problem one of the most important awaiting comprehensive illumination.

Valve Gears.—There are today at least five distinct types of locomotive valve gears available. Some of them claim to be steam and fuel savers or capacity increasers. To be sure, they all have certain maintenance features which warrant consideration. But when it comes down to their relative economies, no scientific data are available for comparing one with the other. When the costs involved are considered together with the far-reaching claims which are made, it is a wonder that a way has not yet been found to secure the steam distributing characteristics of each gear. It would be a service well worth rendering.

Cylinder Proportions.—Locomotive cylinders so proportioned and valve gears so arranged that the maximum cut-off possible ranges from 60 to 70 per cent deserve considerable investigation. Fortunately this is now under way. Results are eagerly awaited.

Piston and Valve Rings, Piston Head and Valve Bull

*Capt. Beyer, now in the Ordnance Reserve Corps, was until recently first assistant in the engineering experiment station, department of railway engineering, University of Illinois.

Rings and Their Wear Limits.—The design, material, number and wear limits of cylinder and valve packing rings, valve bushings, piston heads and bull rings are a continual source of argument and variation in practice. There is no doubt that these small items are of a great deal of importance in the economical performance of the locomotive. What is needed is more definite and extensive data concerning the effect on the steam requirements of the engines equipped with different numbers and different kinds of rings and rings in various conditions of wear. Such tests can easily be made in the locomotive test laboratory. Similar tests can be run with piston heads and valve bull rings of various diameters (such as result from wear) smaller than the cylinders or valve chambers.

The Locomotive Valve.—The diameter, length, weight, speed and stroke of the valve at varying cut-offs have characteristic influences on the indicator card of the cylinders. This should be more completely worked out. Different types, designs, and shapes of valves as a whole might be profitably investigated together with valve bushings and sizes and shapes of port openings.

DESIGN AND CONSTRUCTION

There are investigations which can profitably be made relating to some of the practices employed in locomotive design and construction. A few of these are as follows:

Relative Movement of Boiler Parts.—The systematic study of the movements of various parts of the locomotive boiler when hot, under pressure and working, together with attempts to determine accurately the actual stresses developed, should be continued. As far as carried, this work has revealed that reactions take place which, were they entirely understood, could be controlled or eliminated and the boiler troubles usually experienced thus largely reduced.

Water Circulation in Boilers.—The matter of water circulation in the boiler is very important and little understood, especially as it exists in the big locomotive boiler of today. It probably has a good deal to do with the annoying and treacherous differences in gauge and water glass indications which come into existence when these large boilers are worked at high rates of evaporation. And possibly faulty or limited circulation may have a good deal to do with the varying quality of the steam at the various rates of evaporation, to say nothing about the probable effect of such conditions on the stresses developed in different parts of the boiler. At all events profit is bound to follow a thorough investigation of this subject.

Stress Distribution Throughout the Structure of the Locomotive.—A field of technical study almost entirely untouched is that of the distribution of stresses throughout the structure of the locomotive, as determined experimentally. The mathematical and empirical formulas of the designers based on different kinds of assumptions, can be checked experimentally in a very reliable and thorough manner, with the result, no doubt, that many sources of failure in structure under service conditions can be remedied.

Similarly the question of stresses developed in frames, firebox sheets and other parts of the locomotive by various methods of welding, i. e., thermit, oil, oxy-acetylene, and electric, should be investigated. An entirely new light would

be thrown on the relative merits of these repair processes to say nothing about learning more concerning improved ways for applying them.

Heat Treated and Alloy Steels.—The use of heat treated and alloy steels in locomotive construction deserves a great deal of investigation. The real possibilities along this line will only be appreciated when the use of special steels in the development of the airplane motor is considered. There is, of course, a vast difference between the airplane motor and the steam locomotive, but the one thing that has made the very light, high powered aeromotor possible has been the ingenious use of alloy and heat treated steels. No better object lesson of the possibilities of systematic experimentation in engineering exists to-day than the development of the airplane and its motor. There is no reason why equally gratifying results could not be obtained by a similar intensive application of this method to the locomotive.

GENERAL PERFORMANCE

Considered in its broadest aspect, the locomotive is a combination of materials of engineering which, when operated as a unit will perform more or less economically, exactly in accordance with the ingenuity displayed in selecting, distributing and proportioning these materials. The ultimate purpose of making the many investigations already mentioned is to secure additional data and experience in order to enable the designer, builder and operator of the locomotive to improve its performance in specific directions. But it is also important to know what the sum totals of all these improvements amount to, and compare these totals with other totals so as to effect an intelligent and accurate evaluation of these improvements. Such information is secured by what may be called general performance tests.

Just as with locomotive boilers, so with the locomotive as a whole, but too few overall or general performance tests are available for close performance studies and comparisons of various types. What constitutes the data necessary to determine the entire performance and economy of the locomotive has been standardized to a certain extent by the American Railway Master Mechanics' Association and the American Society of Mechanical Engineers. It is not out of place here to say that this work of code standardization might well continue, especially with the idea in view of establishing as standard at least some of the principal locomotive performance curves, which might be termed, as in the test nomenclature of electrical machinery, characteristic curves. The gradual accumulation of such curves from different locomotives would serve as an increasingly valuable fund of information for all those interested in the development of the locomotive.

Over-All Tests on Locomotives Purchased to Specification.—It is an astonishing situation that the railway industry has not long ago established the practice of calling for certain guaranteed economical performances of new locomotives or even locomotive devices and of running a series of performance or acceptance tests to see whether or not these guarantees have been met. This is a custom pursued by industrial engineers, by marine engineers, and by a large group of other purchasers of machinery and equipment. This situation is increasingly difficult to understand when the initial expenditure as well as the subsequent operating costs of a consignment of new locomotives are compared with the erection and operation of a new power house. No alert industrial engineer would undertake the installation of a steam or hydro-electric power plant without first specifying the limits for performance costs and then, after the plant had been placed in operation, running a complete performance test to check the guarantees. There is no reason why the same system can not be adopted for the steam locomotive. Out of a lot built to certain specifications and guarantees, one might easily be taken and subjected to a complete laboratory performance test, and its entire economy accurately

determined. Such a test would be relatively insignificant in cost, including all overhead charges, when compared to similar tests made on power plants, warships, or merchant ships, and when compared with the cost of the locomotives in one order. Indeed, such a test would hardly add \$50 to the cost of one locomotive of a consignment of one hundred, which would be about 1/10 of 1 per cent of the price of modern locomotives. The incidental modifications and adjustments suggested by the experiment for not only the one locomotive tested, but of all the others secured on the same order would more than justify the expense of the test.

Modernizing Devices.—What has just been stated concerning the locomotive as a whole applies quite as well to such specific parts as the so-called modernizing devices. The lengths to which it is advisable to go in the application of any one or of any combination of these devices depends almost entirely upon the net economies which will be effected by their introduction. The exact effect on operating costs by partially or entirely altering and modernizing old locomotives should be determined by complete performance tests rather than by some of the dubious methods now used.

Determination of Locomotive Characteristics for Use in Scientific Train Loading and Operation.—Complete locomotive performance records as determined from the laboratory tests for securing the objects indicated above, as well as similar tests on other important types of locomotives already in service might well be employed in connection with the establishment of a much more scientific and economically reliable train loading and scheduling system than is now in use. In addition to our present knowledge of the characteristics of train resistance, labor costs, profile, etc., we would also know accurately the drawbar pull and the fuel and water consumption of the locomotive as based on its speed and boiler capacity. The careful application of these characteristics for each class of locomotives in the working out of train schedules and the operating of locomotives and trains in conformance therewith, the establishing of definite standards and the rigid checking of locomotive and train crews on water, fuel and time consumption will effect far-reaching economies, and create much more definite standards of operating costs than are now in existence.

CONCLUSION

Such possibilities as just indicated may perhaps appear rather far-fetched. They would, however, follow from the application of the complete scientific data secured by a careful analysis of the performance of the locomotive in the locomotive laboratory.

Other investigations, both laboratory and statistical, also might have been emphasized above. For instance, relatively little is known about the difference in economy between a locomotive just completely overhauled and one which, according to present day standards, is just ready for general repairs. More light on this point, determined from laboratory tests, might have a decided effect on the shopping policy of many railroads. Little reliable knowledge exists as to the comparative maintenance costs, item by item, of the many distinct types and sizes of locomotives now in service. A thorough statistical investigation on this point would be invaluable. The same is true of the life, service and maintenance costs of specific locomotive parts and devices. There are still other problems which could be mentioned, but it will be quite sufficient for the advance of present day locomotive efficiency if work is started and systematically pursued within the next few years on some of the problems.

The railroads of the United States have been fortunate in having extensive facilities for carrying on the investigations indicated above, but they have remained for the most part indifferent to their opportunities. The time is at hand, however, when this attitude must change. They must resort to more scientific methods to solve the problems now being faced.

THE UNITED STATES STANDARD CARS

Specifications and Principal Drawings of the New Freight Cars to Be Purchased by the Government

ON Monday, March 25, the Director General issued the drawings and specifications for the standard cars recently designed by the government's car committee. These specifications cover designs for bodies of a 40-ton steel underframe, double sheathed box car; a 40 and 50-ton steel frame, single sheathed box car; a 50-ton steel high side gondola car; a 50-ton composite high side gondola car; a 70-ton low side steel gondola car with drop ends, a 55-ton hopper car, and a 70-ton hopper car. There are only three designs of trucks for these cars. They are of 40, 50 and 70 tons capacity. The principal drawings of these cars and trucks have been reproduced and are shown in the following pages. In addition to these specifications will be issued for a 50-ton steel box car, a 30-ton refrigerator and a 50-ton general service car. From a study of these drawings in connection with the specifications, it is quite apparent that the government's standardization committee has provided some cars which no railroad need fear to operate.

Every attempt has been made to make as many parts as possible adaptable to more than one design, in order to reduce the number of dies, patterns, etc., the builders must make in constructing the cars. It is noteworthy the amount of pressed steel shapes that have been used in the designs and the small amount of commercial shapes. Where commercial shapes have been used, however, a strenuous attempt has been made to use the same shapes. For instance, the 12-in., 35-lb. channels are used to a large extent

all three. The limiting dimensions for brake beams is also the same.

The general dimensions of these cars are shown in the table.

The friction type of draft gear has been specified on all cars and the following five types may be used: Cardwell, Murray, Sessions type "K," Westinghouse and Miner. The M. C. B. Type D standard coupler with the 6-in. by 8-in. shank is specified on all cars. M. C. B. specifications have been followed to a large extent and a complete specification for paint is included to be used for all cars. Following is a list of the specifications that are common to the bodies of all of the cars:

Center Sill Requirements.—The center sill construction is designed to meet the M. C. B. requirements, having an area of not less than 24 sq. in. in cross section and a ratio of stress to end load not exceeding .06.

Safety Appliances.—To be applied in accordance with United States safety appliances standard.

Material Options.—Wherever more than one kind of material or construction is shown on drawing or mentioned in specification, it is understood that either may be furnished by the builder unless otherwise specified. Specialties to be as covered in contract.

Bolts and Nuts.—All bolts to have square head and nut unless otherwise specified. All bolts for securing steel against steel to have cotters, lock washers or lock nuts, in

GENERAL DIMENSIONS OF THE UNITED STATES STANDARD FREIGHT CARS

	40-Ton Double Sheathed Box		40 and 50-Ton Steel Frame Single Sheathed Box		50-Ton Steel Gondola	50-Ton Composite Gondola	70-Ton Steel Gondola	55-Ton Hopper	70-Ton Hopper
	40 ft. 6 in.	40 ft. 6 in.	40 ft. 6 in.	40 ft. 6 in.	41 ft. 6 in.	41 ft. 6 in.	46 ft. 6 in.	36 ft. 6 in.	39 ft. 6 in.
Length, inside	40 ft. 6 in.	40 ft. 6 in.	40 ft. 6 in.	40 ft. 6 in.	41 ft. 6 in.	41 ft. 6 in.	46 ft. 6 in.	36 ft. 6 in.	39 ft. 6 in.
Width, inside	8 ft. 6 in.	8 ft. 6 in.	8 ft. 6 in.	8 ft. 6 in.	9 ft. 4 7/8 in.	9 ft. 1 3/8 in.	9 ft. 6 in.	9 ft. 5 1/2 in.	9 ft. 5 1/2 in.
Height, inside	9 ft. 0 in.	9 ft. 0 in.	9 ft. 0 in.	9 ft. 0 in.	4 ft. 8 in.	4 ft. 8 in.	3 ft. 0 in.	3 ft. 0 in.	3 ft. 0 in.
Length over striking plates	42 ft. 1 1/2 in.	42 ft. 1 1/2 in.	42 ft. 1 1/2 in.	42 ft. 1 1/2 in.	42 ft. 10 1/2 in.	42 ft. 10 1/2 in.	48 ft. 7 in.	31 ft. 11 in.	40 ft. 5 in.
Width over eaves	9 ft. 4 in.	9 ft. 4 in.	9 ft. 4 in.	9 ft. 4 in.	10 ft. 2 7/8 in.	10 ft. 2 7/8 in.	10 ft. 3 3/4 in.	10 ft. 2 3/4 in.	10 ft. 2 3/4 in.
Width over all	10 ft. 2 3/4 in.	10 ft. 2 3/4 in.	10 ft. 2 3/4 in.	10 ft. 2 3/4 in.	8 ft. 3/4 in.	8 ft. 3/4 in.	6 ft. 4 3/4 in.	10 ft. 8 in.	10 ft. 8 in.
Height from rail to top of car body	12 ft. 10 1/2 in.	12 ft. 10 1/2 in.	12 ft. 10 1/2 in.	12 ft. 10 1/2 in.	8 ft. 7/8 in.	8 ft. 10 1/4 in.	7 ft. 1 1/8 in.	11 ft. 2 3/4 in.	11 ft. 2 1/4 in.
Height from rail to top of brake mast	14 ft. 1 1/4 in.	14 ft. 1 1/4 in.	14 ft. 1 1/4 in.	14 ft. 1 1/4 in.	8 ft. 7/8 in.	8 ft. 10 1/4 in.	7 ft. 1 1/8 in.	11 ft. 2 3/4 in.	11 ft. 2 1/4 in.
Height from rail to top of running board	13 ft. 6 7/8 in.	13 ft. 6 7/8 in.	13 ft. 6 7/8 in.	13 ft. 6 7/8 in.	31 ft. 10 1/2 in.	31 ft. 10 1/2 in.	37 ft. 7 in.	21 ft. 11 in.	30 ft. 5 in.
Distance center to center of trucks	31 ft. 1 1/2 in.	31 ft. 1 1/2 in.	31 ft. 1 1/2 in.	31 ft. 1 1/2 in.	2 ft. 10 1/2 in.	2 ft. 10 1/2 in.	2 ft. 10 1/2 in.	2 ft. 10 1/2 in.	2 ft. 10 1/2 in.
Height from rail to center of coupler	2 ft. 10 1/2 in.	2 ft. 10 1/2 in.	2 ft. 10 1/2 in.	2 ft. 10 1/2 in.	2 ft. 4 1/2 in.	2 ft. 4 1/2 in.	2 ft. 4 1/2 in.	2 ft. 4 1/2 in.	2 ft. 4 1/2 in.
Height from rail to bottom of center sill	2 ft. 4 1/2 in.	2 ft. 4 1/2 in.	2 ft. 4 1/2 in.	2 ft. 4 1/2 in.	1,820 cu. ft.	1,770 cu. ft.	1,880 cu. ft.	2,508 cu. ft.	2,508 cu. ft.
Cubic capacity—level full	2,310 cu. ft.	2,230 cu. ft.	2,310 cu. ft.	2,230 cu. ft.	42,600 lb.	40,000 lb.	49,500 lb.	40,000 lb.	49,500 lb.
Cubic capacity—with 30 deg. heaped	44,000 lb.	44,000 lb.	44,000 lb.	44,000 lb.					
Estimated weight									

for the center sills. The end sills, and in some cases side sills, are made up of 9-in., 17.44-lb. shipbuilding channels. In the open-top cars a 13.2-lb. bulb angle is used on practically all the designs. The draft sill arrangement is identical, with the exception of some details, to all cars, and a standard distance of 12 7/8 in. is maintained between the center sills.

CAR BODY SPECIFICATIONS

In addition to this, detail parts have been made of the same designs where it has been possible to do so, among which may be mentioned the body center plate, body side bearing, front draft lug, striking plate, coupler yoke key and cotter, coupler carrying iron and ladder rounds and grab irons. These are common to all of the designs. There are also other parts which are common to more than one design. For instance, one design of body bolster, center brace, rear draft lug and draft sill is used for the 40- and 50-ton single sheathed box cars, the 50-ton steel gondola and the 50-ton composite gondola. The trucks are similar in construction and have a center plate and center plate support common to

addition to common nut, and all bolts for securing wood against steel to be riveted over nuts.

Brakes.—Cars to be equipped with Westinghouse KD-10-12 type (the box cars are to be equipped with the KC-10-12 type) of air brakes of either Westinghouse or New York Air Brake Company's manufacture. Hose and gaskets to meet M. C. B. specifications. Brakes to be applied to all wheels and also arranged to be operated from one end of the car by hand. Braking power to be about 60 per cent of light weight of car based on 50-lb. cylinder pressure. Piston travel to be between 5 and 7 in. Hand brake power to be approximately the same as the air brake power. All piping to be black steel, merchantable, standard weight, and fittings to be malleable iron.

Draft Gear.—To be of the friction type, having a minimum capacity of 150,000 lb. and a maximum travel of 2 3/4 in., designed so as to fit into the space provided by the drawings. Clearance between coupler horn and striking plate to be 3 in. The following types may be used: Cardwell, Murray, Sessions type "K," Westinghouse, Miner.

Drawbar Yoke.—To be of the vertical plane type of an

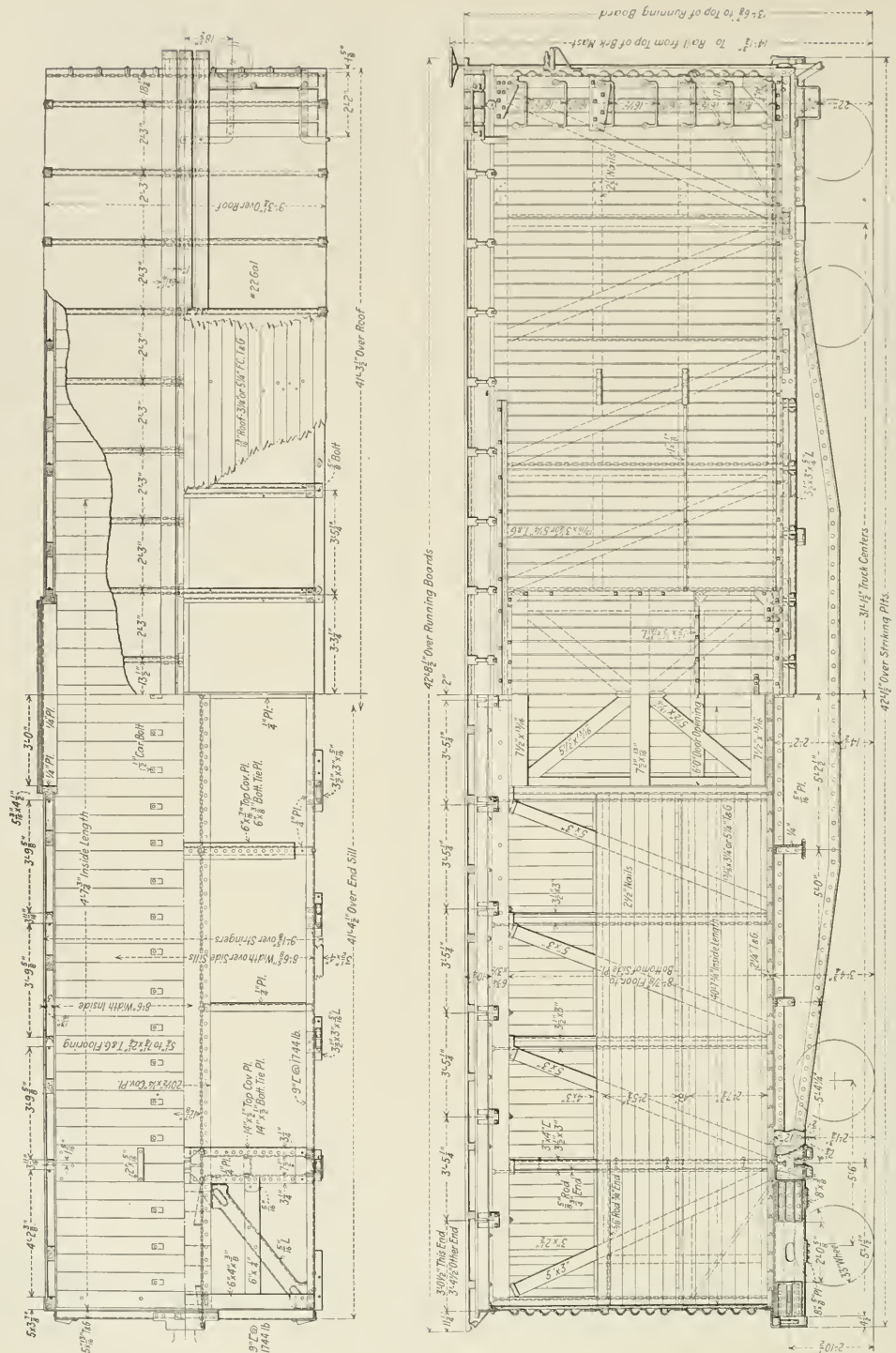

Fig. 1—General Plan for the Standard 40-Ton Double Sheathed Box Car

approved design, arranged to take the key shown on drawing.

Coupler.—To be cast steel, in accordance with M. C. B. contour and specification, having 6-in. by 8-in. shank, 21¼ in. long, as shown on coupler condition drawing, and slotted tail of proper depth to suit draft gear.

Coupler Operating Device.—To be of the top operating type without the use of clevises, links and pins; that is, to be direct connected to the locking block. Apparatus to be in accordance with condition drawings.

Center Plate.—To be, first, drop forged, or second, cast steel.

Side Bearing.—To be, first, frictionless, or second, plain. Frictionless side bearings to be of approved type to meet conditions shown on drawing. Drawings are arranged so that plain side bearing can be used in repairs.

Material Specifications.—The following M. C. B. specifications for materials are to apply.

Air brake hose.	Mild steel bars.
Air brake hose gaskets.	Steel castings.
Air brake hose label.	Pipe unions.
Boiled linseed oil.	Raw linseed oil.
Bolts and nuts.	Red lead.
Carbon steel bars for railway springs.	Rivet steel and rivets.
Cbains.	Structural steel, steel plate and steel sheets for freight equipment cars.
Couplers.	Turpentine.
Helical springs.	Welded pipe.
Japan drier.	White lead for lettering.
Malleable iron castings.	Wrought iron bars.

FREIGHT CAR PAINT SPECIFICATIONS

For Use on All Cars

Freight Car Color. I. This material will be bought in the paste form, and the paste must contain nothing but oil, pigment and moisture.

of any of these, sulphate of lime and silica preferred. The pigment should have the following composition:

Sesquioxide of iron.....	25	per cent by weight
Inert material.....	71½	per cent by weight
Carbonate of lime.....	3½	per cent by weight

V. Material must conform to shade furnished and in fineness of grinding meet test in accordance with approved method of Standard Railway laboratories.

VI. Shipments will not be accepted which:

1. Contain less than 23 per cent or more than 27 per cent of oil.
2. Contain more than 2 per cent volatile matter, including the moisture, the oil being dried to 250 degrees Fahrenheit, and the pigment dried in air which has been passed through oil of vitriol, at from 60 degrees to 90 degrees Fahrenheit.
3. Contain impure or boiled linseed oil.
4. Contain in the pigment sulphate of lime not fully hydrated, less than 20 per cent of sesquioxide of iron, less than 2 per cent or more than 5 per cent of carbonates, calculated as carbonate of lime, or have present any barytes, carbonates of alkalis, aniline colors, lakes or any other organic coloring matter, or any soaps or other emulsifying material.
5. Vary from shade.
6. Do not pass fineness of test.
7. Are a liver or so stiff when received that they will not readily mix for spreading.

Carbon Black. I. This material must be furnished in paste form.

II. The material desired under this specification is a paste, made on the following formula:

Pigment.....	65	per cent by weight
Oil.....	35	per cent by weight

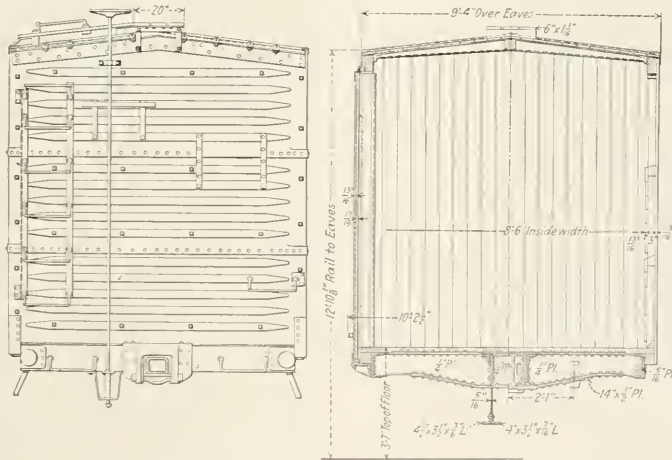

Fig. 2—Sections of the 40-Ton Double Sheathed Box Car

II. The proportions of oil, pigment and moisture must be as nearly as possible as follows:

Pigment.....	74	per cent by weight
Oil.....	25	per cent by weight
Moisture.....	1	per cent by weight

III. The oil must be pure raw linseed oil, as free as possible from foots, and well clarified by settling and age.

IV. The pigment desired if it contains sulphate of lime or gypsum should have this fully hydrated. It may be as inert material sulphate of lime of gypsum fully hydrated, silica, kaolin, soapstone or asbestine, or mixtures

The oil must be pure raw linseed oil, as free as possible from foots, and well clarified by settling and age.

The pigment desired should consist of:

Lampblack, of carbon black.....	15	per cent
Red lead.....	5	per cent
Asbestine.....	10	per cent
Silicx or other approved material.....	70	per cent

The lampblack must be of good quality, and of such a character as to produce the standard shade. Ground coal, etc., will not be considered. Phosphates, barytes, sulphates of lime or gypsum, carbonate of lime or whiting or any other carbonates or sulphates, or any constituents other than

those given in the composition of the pigment desired, must not be used.

III. Material must conform to shade furnished and in

2. Contain more than 2 per cent of volatile matter, including the moisture, the oil being dried at 250 degrees Fahrenheit, and the pigment dried in air which has been

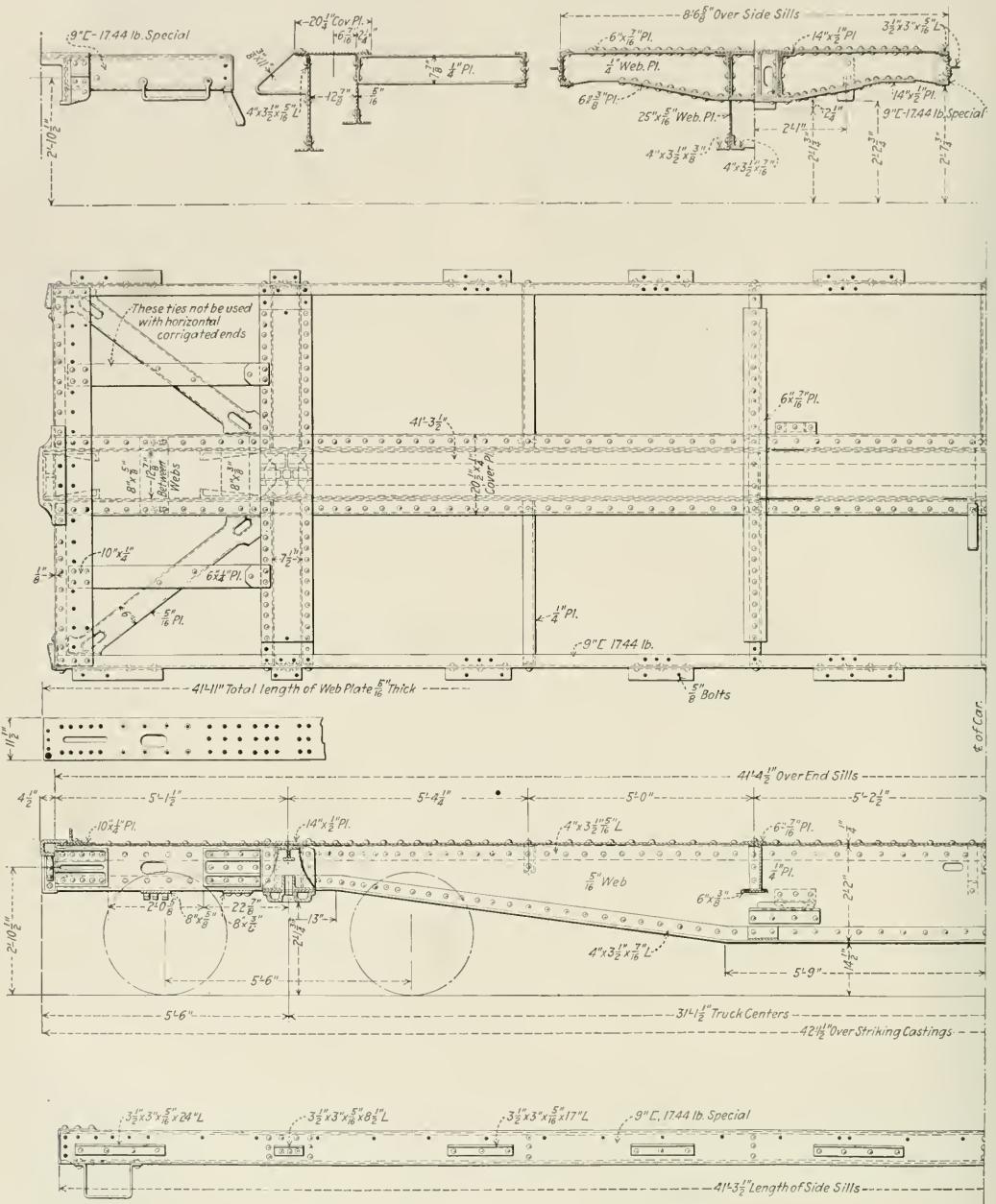

Fig. 3—Underframe of the Standard 40-Ton Double Sheathed Box Car

fineness of grinding meet test in accordance with approved method of Standard Railway laboratories.

IV. Shipments will not be accepted which:

1. Contain less than 32 or more than 38 per cent oil.

passed through oil of vitriol at from 60 to 90 degrees Fahrenheit.

3. Contain impure linseed oil.

4. Contain in the pigment less than 13 per cent or more

than 16 per cent carbon, preferably in the form of lamp-black or carbon black, less than 4 per cent of lead representing the red lead, or have present any phosphates, barytes, sulphate of lime or gypsum, carbonate of lime or whiting, or any other sulphates or carbonates or any other caustic substances, such as caustic lime, or any soaps or other emulsifying materials, or any constituents other than

seed oil, the balance to be liquid drier and volatile thinner. The volatile thinner may be turpentine or mineral spirits or a mixture of the two. No rosin shall be present in the vehicle.

The prepared paint as received must have satisfactory working qualities and durability. It must be free from objectionable caking in the can. When applied to a smooth

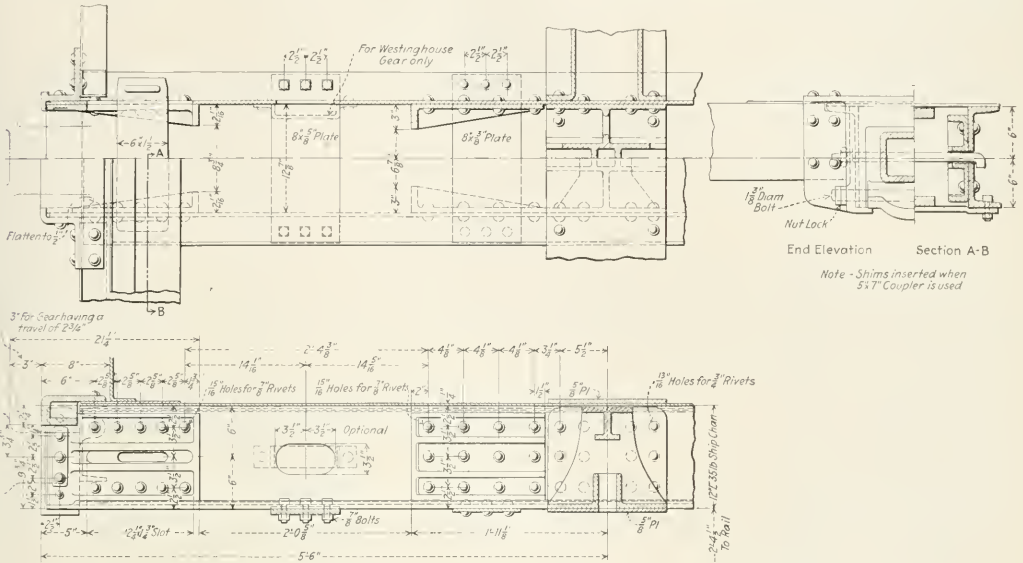

Fig. 4—Draft Sill Construction for the Box and the 50-Ton Steel and Composite Gondola Cars

those given in the formula for the pigment desired.

5. Do not pass fineness test.
6. Do not contain asbestos according to the formula of the pigment desired.
7. Are a liver, or so stiff when received that they will not readily mix for spreading.

Red Lead. This paint shall be furnished in prepared

iron surface it must dry in twelve hours without running, streaking or sagging.

BOX CARS

All designs of the box cars have a steel underframe and steel ends. The bodies of the 40- and 50-ton single sheathed box cars are identical; the only difference is in the trucks. The specifications peculiar to the box cars and

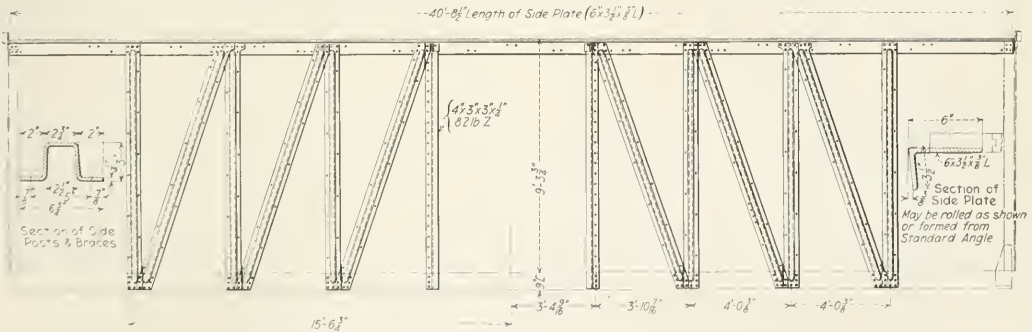

Fig. 5—Side Construction for the Standard Single Sheathed Box Cars

form ready for application. It shall contain not less than 64 per cent or more than 68 per cent of pigment. The pigment portion of the paint shall contain 60 per cent red lead. The red lead used shall contain not less than 85 per cent Pb_3O_4 . The balance of the pigment portion of the paint shall consist of silicious matter such as magnesium or aluminum silicate or silica or a mixture thereof.

The vehicle shall consist of not less than 90 per cent lin-

similar to all of the box car designs are as follows:

Flooring.—To be of fir or long leaf yellow pine, square edge and sound, 2 1/4 in. thick, tongued and grooved, 5 1/4-in. to 7 1/4-in. face width, secured to side and center sills, as shown on drawing.

End Lining.—To be yellow pine, No. 1 common, or fir 1 1/2 in. thick, tongued and grooved, 5-in. face width.

Roof.—To be galvanized steel No. 22 gage, outside metal

roof, laid over yellow pine roof boards, No. 1 common, or fir 13-16 in. thick by 3 1/4-in. or 5 1/4-in. face width as shown on drawing No. 1337. (The drawings state that the Murphy, Hutchins, or Chicago-Cleveland outside roofs may be used if they interchange with the designs shown.)

and grooved, 3 1/4-in. or 5 1/4-in. face width, securing to framing as shown on drawings.

Side Lining.—To be yellow pine, No. 1 common, or fir 13/16 in. thick, tongued and grooved, 3 1/4-in. or 5 1/4-in. face width, secured to framing, as shown on the drawings.

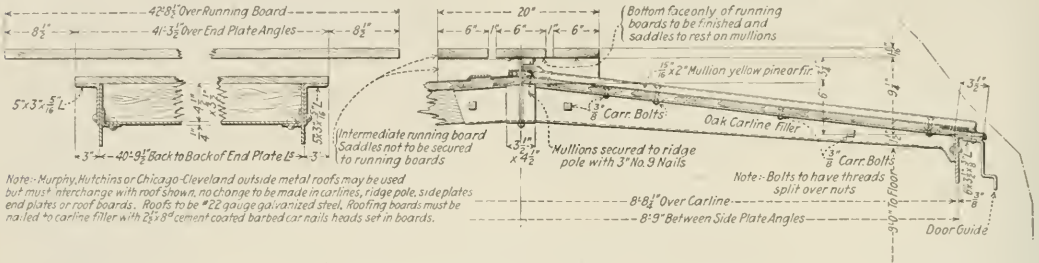

Fig. 6—Roof Construction for the Standard Box Cars

Steel Ends.—First, horizontal corrugated of three sheets; top sheet 3-16 in. thick, intermediate and bottom sheets 1/4 in. thick with corrugations 2 1/4 in. deep. Second, vertical corrugated of two sheets, all 1/4 in. thick with corrugations 2 1/4 in. deep. Third—Plain steel end with U-shape vertical stakes, as shown on drawings.

The side lining for the 40- and 50-ton steel frame, single sheathed box cars is to be of, first, fir No. 2 clear and better, or second, yellow pine B and better. Lumber is to be thoroughly kiln dried, having maximum moisture of 5 per cent, tongued and grooved and with a 5-in. face.

The designs are illustrated in Figs. 1 to 10 inclusive.

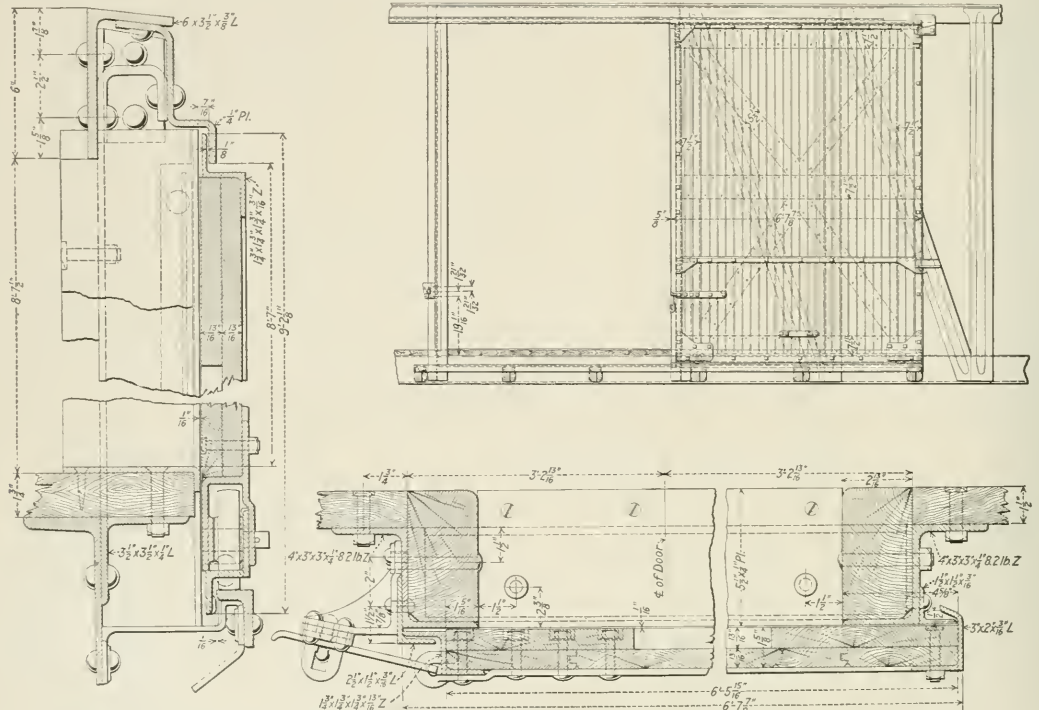

Fig. 7—Box Car Door for the United States Standard Cars

The following specifications apply only to the 40-ton steel underframe double sheathed box car:

Framing.—All dimension framing to be yellow pine, square edge and sound grade, or fir of sections shown on drawings.

Side Sheathing.—To be long leaf yellow pine, B and better, or No. 2 clear and better fir 13/16 in. thick, tongued

and grooved in the construction of the bodies of the double-sheathed and single-sheathed cars which are the same in both. In many cases the same steel pressings and commercial shapes are common to both types of cars. A brief description of the construction of these cars follows:

Forty-Ton Double Sheathed Box Car.—This design has an estimated weight of 44,000 lb. The general plan of this

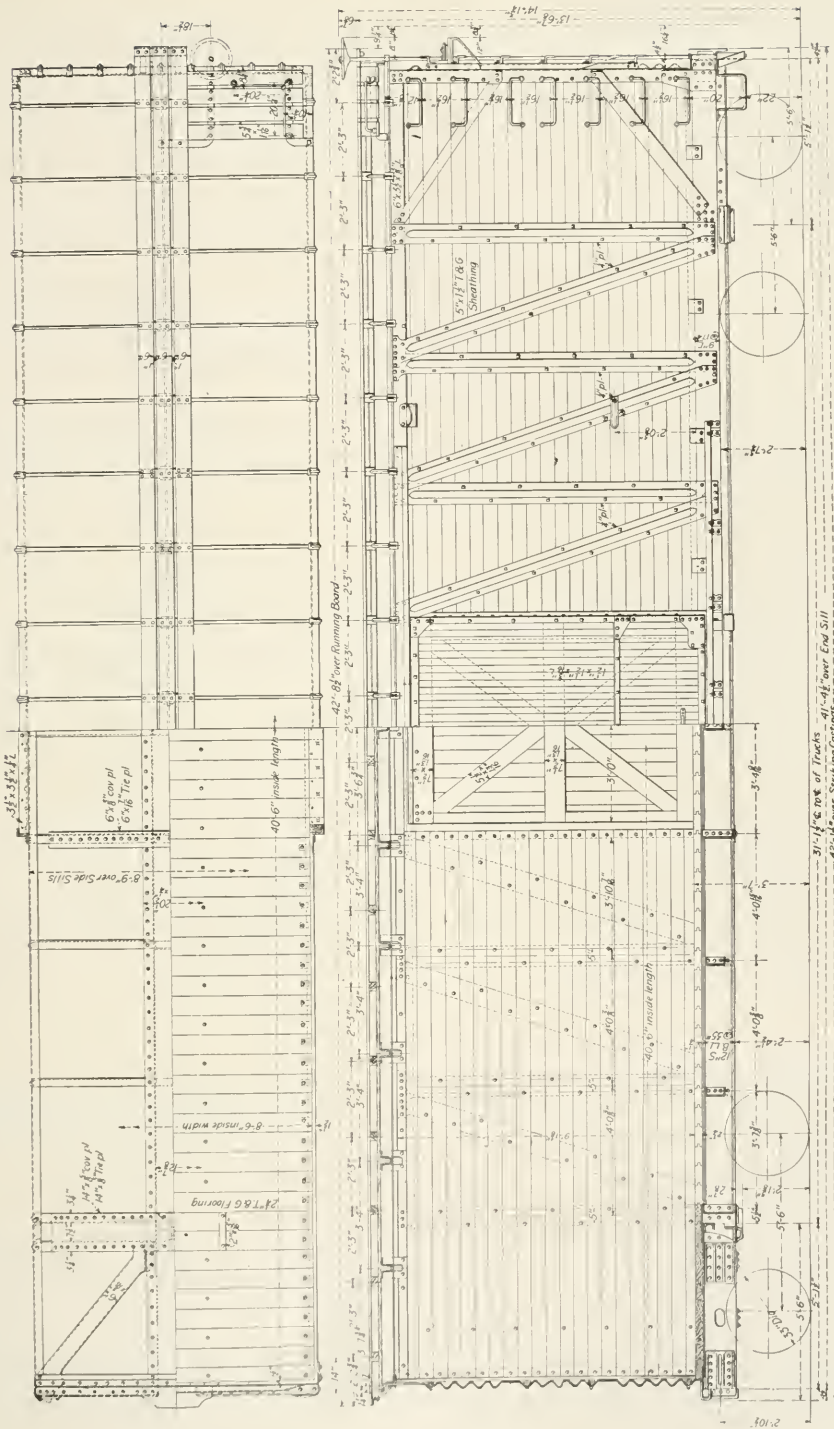

Fig. 8—General Plan for the Standard 40- and 50-Ton Steel Frame, Single Sheathed Box Car

car is shown in Figs. 1 and 2 and the underframe is shown in Fig. 3. The underframe has a center sill of the fish-belly type, which is 2 ft. 2 in. deep at the center. It is made up of 5/16-in. web plates, with a top 4-in. by 3½-in. by 5/16-in. angle and a bottom 4-in. by 3½-in. by 3/8-in. angle on the outside and a 4-in. by 3½-in. by 7/16-in. angle on the inside of the web plate. There is a top cover plate 20½ in. wide by ¼ in. thick. The draft sills are shown in Fig. 4. There are two crossbearers made up of ¼-in. pressed steel diaphragms, having a top cover plate 6 in. by 7/16 in. and a bottom cover plate which extends through the webs of the sills, of 6-in. by 3/8-in. plate. The body bolsters are built up of ¼-in. pressed steel diaphragms and have top and bottom cover plates 14 in. by ½ in., which extend almost out to the side sills. The side and end sills are 9-in. shipbuilding channels, which are used so commonly throughout the design of these cars. The end sills are made from the standard 9-in. shipbuilding channels. There is a diagonal brace extending from the junction of the center sill with the body bolster to the corners made of 5/16-in. plate. A 6-in. by ¼-in. plate extends between the body bolsters and the end sill midway between the center sills and the side sills to further reinforce the ends. These are riveted to the diagonal brace mentioned above.

The superstructure of the car is of standard double

The general plan and sections of this car are shown in Figs. 8 and 9 and the underframe is shown in Fig. 10. In common with the double sheathed car, they have the underhung door and the same draft sills. The center sills are 12-in. ship-building channels. These cars have two crossbearers made up of ¼-in. pressed steel diaphragms with a 6-in. by 3/8-in. top cover plate and a 6-in. by 7/16-in. bottom cover plate. The bolsters are made up of 15/16-in. pressed steel diaphragms with a 14-in. by 5/8-in. top and bottom cover plate. The side sills and end sills are 9-in. shipbuilding channels.

The side posts and braces are of pressed steel U-sections, made from ¼-in. plate. These are riveted to the side sill and to a 6-in. by 3½-in. by 3/8-in. angle, which forms the side plate. The sheathing used for these cars is 5-in. wide by 1½ in. thick. The roof construction is the same in general as that of the double sheathed car. The carlines are made of 5/32-in. open hearth steel pressed to a U-shape, 4½ in. deep.

GONDOLA CARS

The gondola cars are designed to carry a concentrated load of two-thirds of the capacity of the car over a distance of 10 ft. at the center. Eight doors are provided on the 50-ton all-steel and composite high side cars. Those on the all-steel

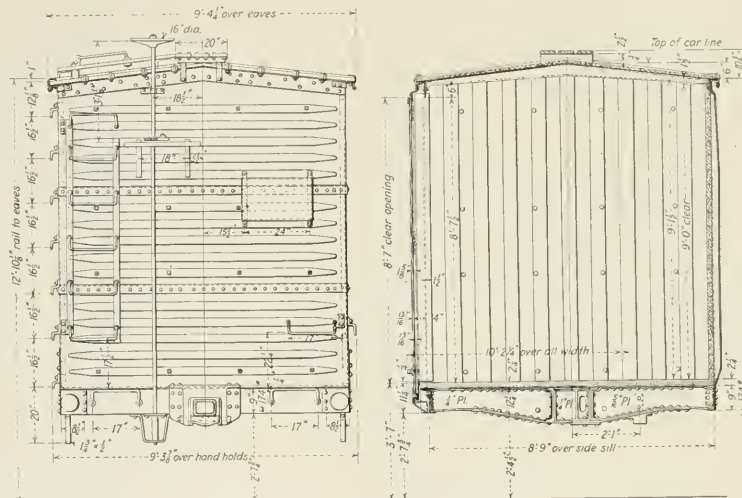

Fig. 9—Sections of the 40- and 50-Ton Single Sheathed Box Car

sheathed construction, with 3½-in. by 3-in. posts and 5-in. by 3-in. braces. The side construction is shown in Fig. 5. The side posts are reinforced by the 3-in. 4-b. channel, which fits over the post, being bolted to it, and by a 5/8-in. tie rod which extends between the side plate and the side sill. The last intermediate side post is tied to the corner post by 5/8-in. rods at the upper belt rail. The brace and side post pocket casting of the same post is tied to the end of the car by a diagonal tie rod 1½ in. in diameter. The side plates are 6¾ in. by 3½ in. A section through the roof is shown in Fig. 6.

The doors are shown in Fig. 7. They are made up of 7½-in. by 13/16-in. transverse and vertical framing, with 5½-in. by 13/16-in. diagonal braces. They are of the underhung type. A 1½-in. by 1½-in. by 13/16-in. angle is placed on the outside for additional stiffness.

Forty and Fifty-Ton Single Sheathed Box Cars.—These cars will weigh 44,000 lb., the same as the other box car.

car are hinged cross-wise of the car, while those on the composite car are hinged along the center sill to dump toward the side. In both cases the doors are operated in pairs. The flooring for the composite cars is to be of long leaf yellow pine or fir, 2¾ in. thick, having a face of 5¼ in. to 7¼ in. The siding for these cars is of long leaf yellow pine or fir and 1¾ in. thick.

The underframe on all three of these designs is not the same in its entirety. There are, however, details which are similar. For instance, the draft sill construction and the body bolster center brace of both the 50-ton gondolas are the same as those used on the single sheathed box cars. The body bolster center brace and the rear of draft lug on the 70-ton gondolas are the same as those used on the 40-ton double sheathed box car. There are similarly other details which are common to the various designs.

The drawings for the gondola cars are shown in Figs. 11, 12, 13, 14 and 15. There is a marked similarity

in the general dimensions between the 50-ton steel and composite cars.

Fifty-Ton Composite Gondola.—This car has an estimated

other designs is made up of a number of steel pressings. The center sills are 12-in. channels, having a standard distance of $12\frac{7}{8}$ in. between the webs and a top cover plate $20\frac{1}{2}$ in.

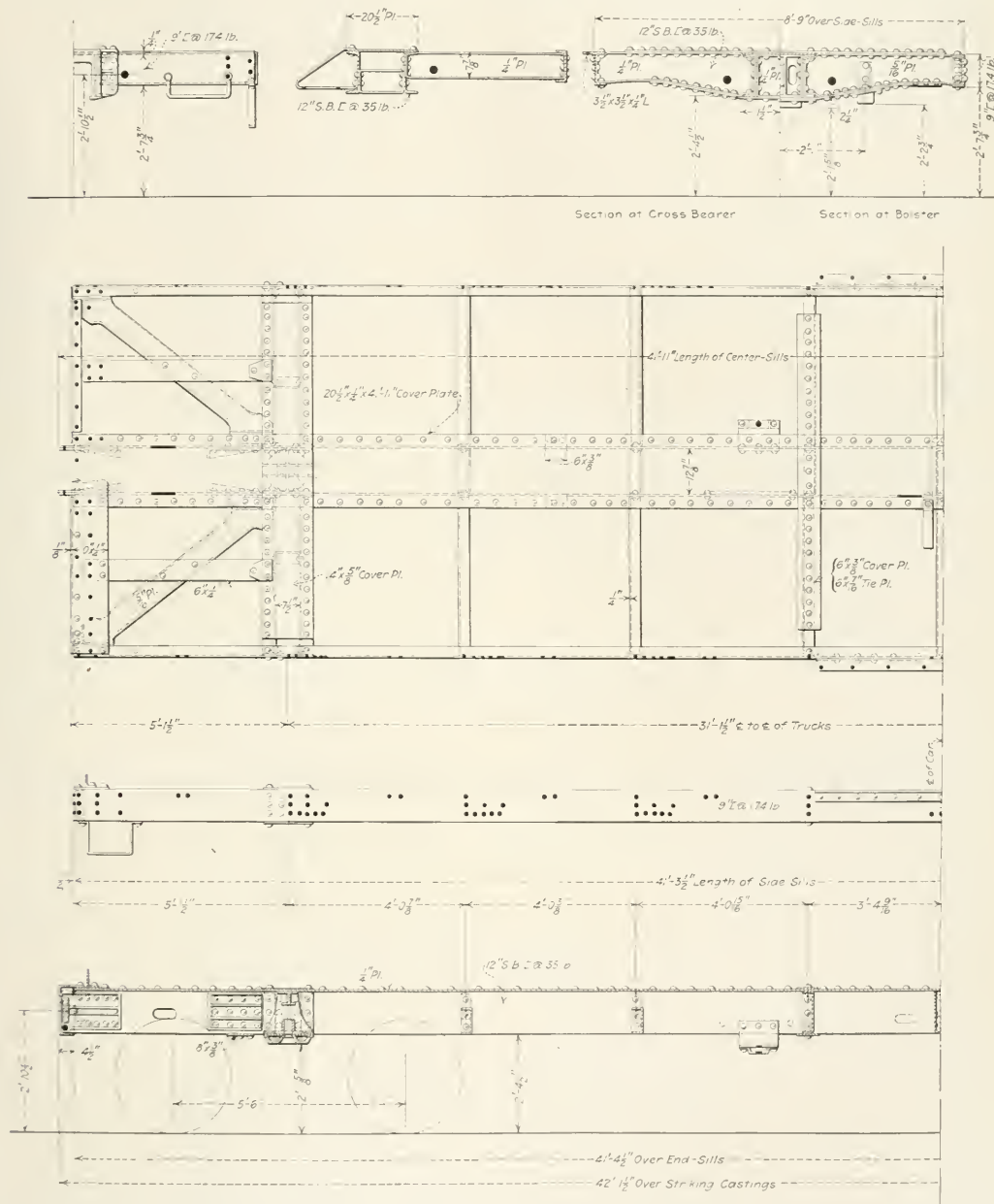

Fig. 10—Underframe of the 40- and 50-Ton Standard Single Sheathed Box Car

weight of 40,000 lb. It has eight drop doors swinging from the center sill, the general plan being shown in Fig. 11.

The underframe, shown in Fig. 12, in common with the

by $1\frac{1}{4}$ in. There are four crossbearers of the fish-belly type, made up of $\frac{1}{4}$ -in. pressed steel diaphragms, having top and bottom cover plates of 8-in. by $\frac{3}{4}$ -in. material. The side sills

are 9-in., 17.44-lb. shipbuilding channels. The body bolsters are built up of steel diaphragms made from 5/16-in. steel plate, having top and bottom cover plates of 5/8-in. steel. The end sills are 9-in., 17.44-lb. ship channels.

The body of the car has eight U-shaped pressed steel stakes on each side and six braces of the same material. These are made from 1/4-in. plates and are 7 1/4 in. wide and 3 1/2 in. deep. The end braces are also pressed from a steel plate in U-sections, being 7 1/4 in. wide, 4 in. deep and 1/4 in. thick. There is a 5-in. by 3 1/2-in. by 3/8-in., 13.2 lb. bulb angle,

cover plates 3/8 in. thick and 5 ft. 8 1/2 in. long, with no top cover plate. The side construction consists of 3 1/2-in. by 3-in. by 1/2-in. angles and side stakes of the same dimensions as those used in the composite car, but made from 5/16-in. plate. The end braces and the end sills are the same as used in the composite car. Both the floor and side plates for this car are 1/4-in. sheets, and the same bulb angle is used at the top of the sides as on the composite car.

Seventy-Ton Steel Gondola.—This design has an estimated weight of 49,500 lb. It is to be built entirely of steel

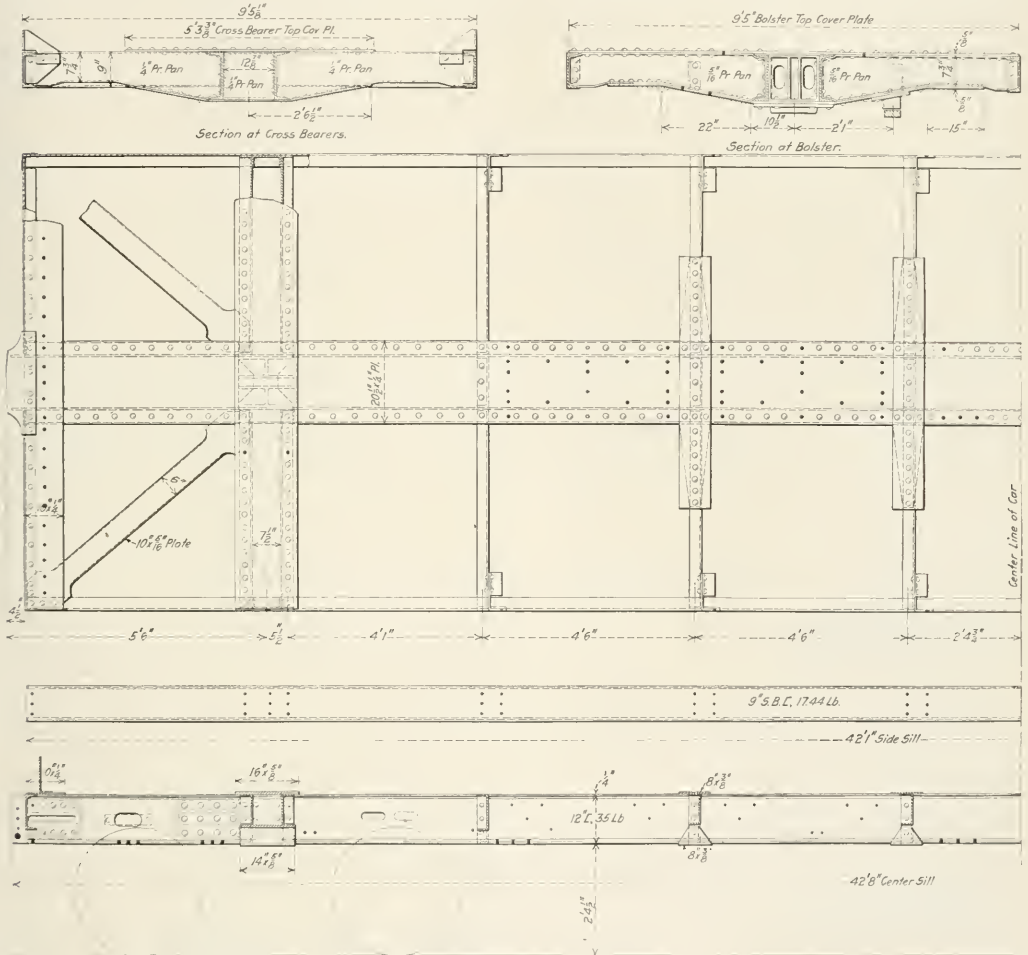

Fig. 12—Underframe for the 50-Ton Composite High Side Gondola

extending around the top sides and ends. The floor boards are 2 3/4 in. thick and the side boards are 1 3/4 in. thick.

Fifty-Ton Steel Gondola Car.—This car has an estimated weight of 42,000 lb. As in the composite design, it has eight drop doors which are set flush with the floor. The general plan of this car is shown in Fig. 13, and the underframe is shown in Fig. 14.

The chief difference between the underframe of this car and that of the composite gondola is in the crossbearers and side sills. The crossbearers are straight, being made of 1/4-in. pressed steel pans 12 in. deep. They have bottom

and is provided with drop ends. The general plan of this car is shown in Fig. 15, and the underframe, in Fig. 16.

This car has a center sill of the fish-belly type, being 2 ft. 6 in. deep at the center. The center sill girder has a 3/8-in. web plate with a top flange angle 4 in. by 3 1/2 by 3/8 in., bottom flange angles on each side of the webs 4 in. by 3 1/2 in. by 7/16 in. and a top cover plate 21 in. wide by 1/4 in. thick. The crossbearers are 1/4-in. pressed steel diaphragms 16 1/8 in. deep at the center, reinforced at the bottom by a 6-in. by 3/8-in. cover plate which passes through the web of the center sill. The body bolsters are of the same

general construction as those used on the other gondola cars, having 3/8-in. top and bottom cover plates. The bottom side angle used in this design is 4 in. by 3 1/2 in. by 1/2 in., and the same bulb angle is used at the top of the sides. The side, end and door sheets of the car are 1/4 in. thick. There are 24 pressed steel stakes made from 5/16-in. plate.

HOPPER CARS

The hopper cars are of all-steel construction, the 55-ton car having double hoppers and the 70-ton, triple hoppers. The four doors forming the center opening in the 70-ton car are operated by one mechanism and in all other cases the

building channels. The standard 5-in. bulb angle is used at the top of the sides and ends. There are 12 side stakes of U-section pressed from 1/4-in. plate. The side, end and floor plates are 1/4 in. thick, with the exception of the last panel at the sides and the top panel on the ends, which is 3/16 in. thick. Two 6-in., 8-lb. channels form the end posts.

Seventy-Ton Hopper Car.—This car has an estimated weight of 49,500 lb. The center sill and plates are very similar to the 55-ton car. The body bolsters are made up of 5/16 web plates with 3/4-in. reinforcing plates, 3 1/2-in. by 3 1/2-in. by 3/8-in. bottom angles and a 14-in. by 1/2-in. bottom cover plate. The side stakes are pressed from 1/4-in.

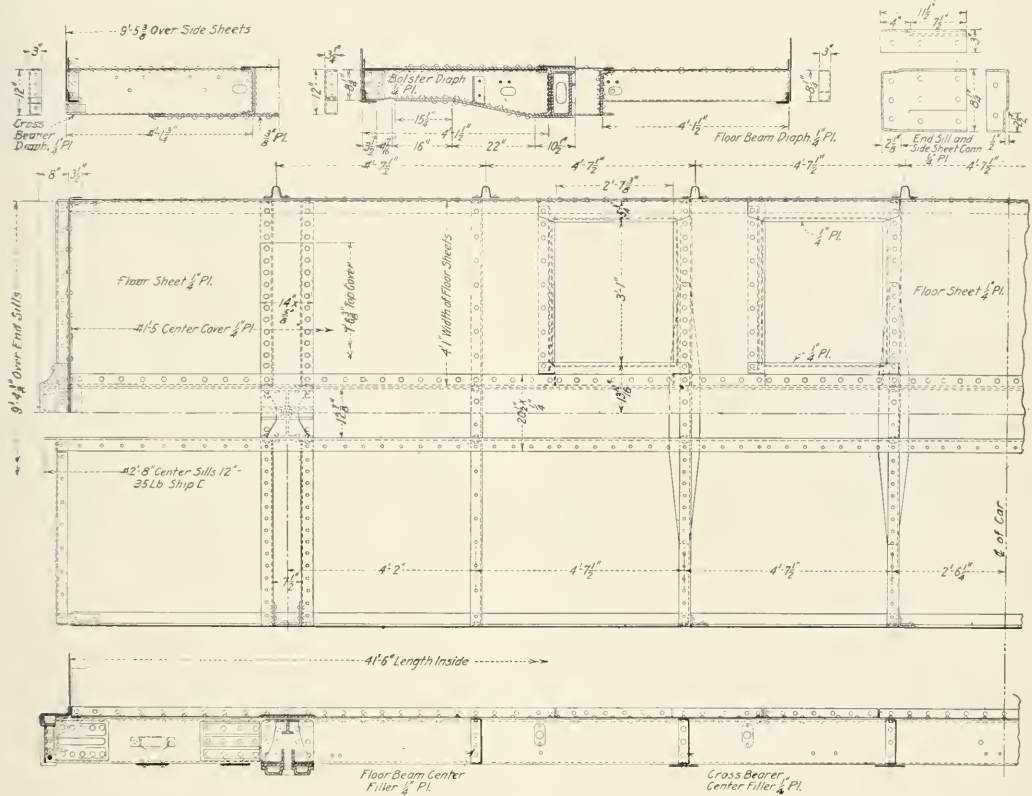

Fig. 14—Underframe for the Standard 50-Ton Steel Gondola Car

doors forming the openings are operated in pairs. These cars have the same end and draft sill and have the same design of rear draft lug. There are many details in the door opening mechanism which are common to both types of cars. The floor construction is the same and the hopper construction with the details is common to both. The side hopper sheets are the same.

The elevation and sections of the 55-ton car are shown in Fig. 17, and those for the 70-ton car in Figs. 18 and 19.

Fifty-five-Ton Hopper.—This car has an estimated weight of 40,000 lb. It has the 12-in. channel center sills, which are reinforced at the ends by a 4-in. by 3 1/2-in. by 3/8-in. angle. The center sills cover plate is 12 1/2 in. wide by 15/16 in. thick. The body bolster is built up of a 5/16-in. plate, with reinforcing plates 3/8-in. thick and bottom angles 3 1/2-in. by 3 1/2-in. by 3/8-in. There is a bottom cover plate 14 in. wide of 1/2-in. plate. The end sills are 9-in. ship-

plate, and the end posts are 6-in., 8-lb. channels with 3 1/2-in. by 3 1/2-in. by 5/16-in. angle corner posts.

TRUCKS

The trucks for all of the standard cars are covered by three specifications, one for 40-ton cars, one for 50-ton cars and one for 70-ton cars. Following are the general dimensions:

	40-ton	50-ton	70-ton
Wheel base	5 ft. 6 in.	5 ft. 6 in.	5 ft. 8 in.
Distance center to center of journals	6 ft. 4 in.	6 ft. 5 in.	6 ft. 6 in.
Size of journals	5 in. by 9 in.	5 1/2 in. by 10 in.	6 in. by 11 in.
Diameter of wheels	33 in.	33 in.	33 in.

The specifications for all three trucks are similar, the provisions in the majority of cases being identical. The trucks for the 40- and 70-ton cars are each required to be of ample strength to carry a load 10 per cent above the rated capacity in addition to the light weight of the car body. The 50-ton

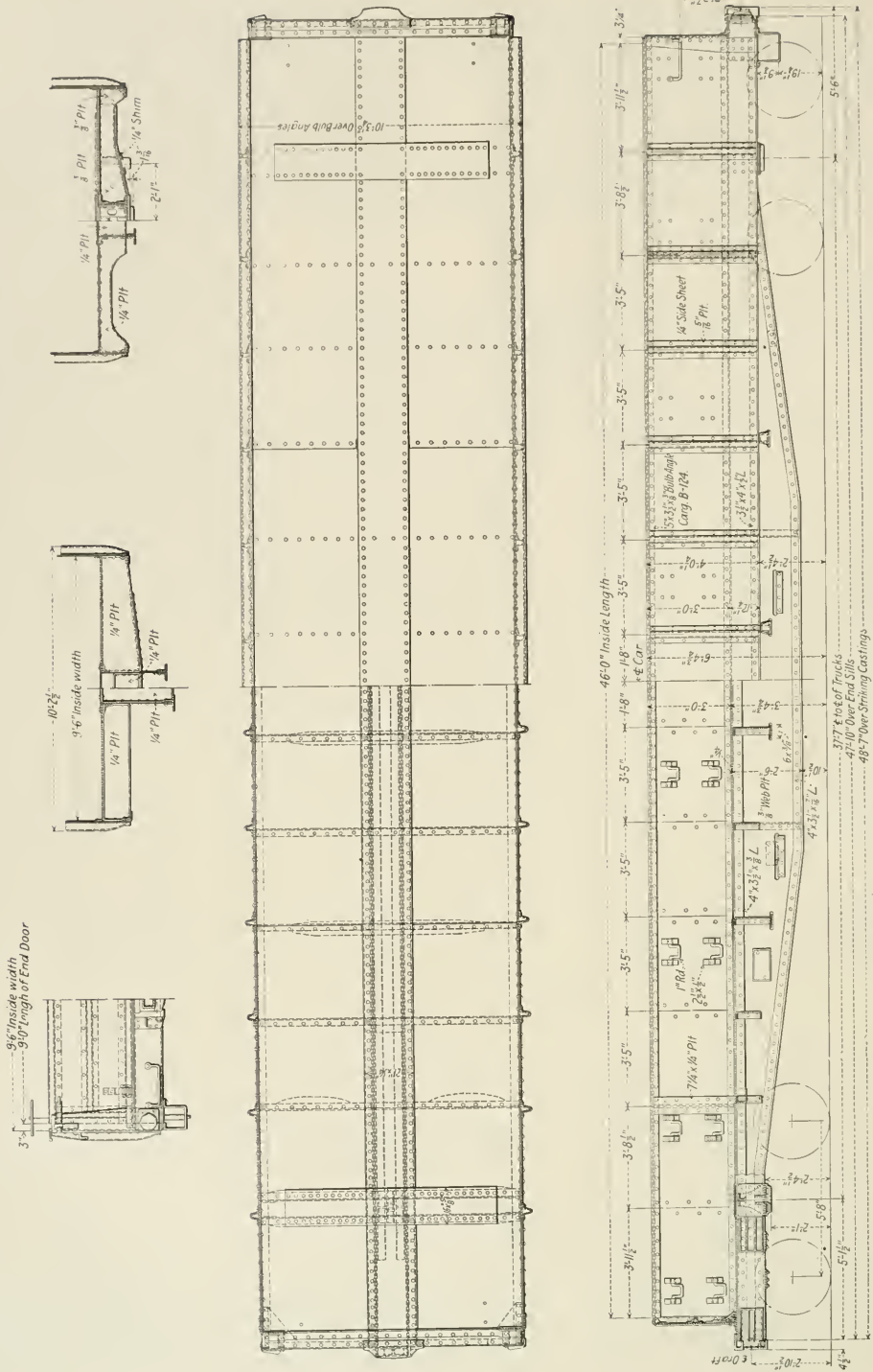

Fig. 15—General Plan of the Standard 70-Ton Low Side Gondola Car

truck, while nominally for cars of that capacity, is required to carry a load of 121,000 lb. in addition to the light weight of the car body, thus making it available for use under 55-ton cars. Except in the case of those sections which are not identical for all three trucks, the text of the specifications is given below. Sections where differences occur have been summarized to cover all three trucks and the difference clearly pointed out.

Material Options.—Wherever more than one kind of material or construction is shown on drawing or mentioned in specification, it is understood that either may be furnished

specifications with arch bar truck where this type of truck is permitted. They must be made in accordance with M. C. B. specifications and have a transverse section modulus in the top member of eight for the 40-ton truck, 10 for the 50-ton truck, and 12 for the 70-ton truck.

Truck Bolsters.—To be: (1) Cast steel bolster with integral center plate; (2) cast steel bolster with separate center plate, or (3) pressed steel or built-up bolster. Inside bearing surface of cast steel center plate to be dressed. Cast steel and built-up bolsters must interchange with pressed steel bolsters. Cast steel bolsters must have a section mod-

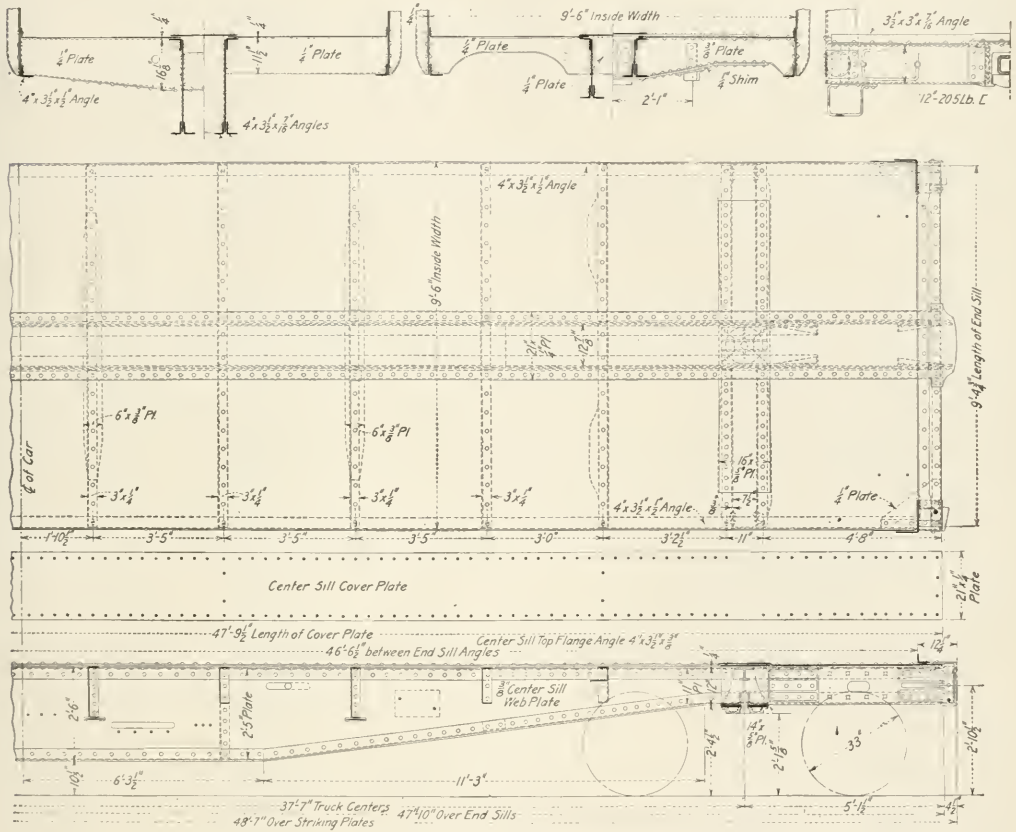

Fig. 16—Underframe for the 70-Ton Steel Gondola Car

by the builder unless otherwise specified. Specialties to be as covered in contract.

Forgings.—Forgings may be made of either steel or wrought iron.

Truck Frames.—For the 40- and 50-ton trucks, the truck frames are to be: (1) Cast steel side frame of U-section members with M. C. B. standard removable journal box; (2) cast steel side frame of U-section members with journal box cast integral, or (3) arch bar type. Except for the exclusion of the arch bar type, the same types of side frame are specified for the 70-ton truck.

The bars for cast steel truck side frame to be of the short type, two per frame.

Cast steel side frame must meet limiting dimensions shown on limiting dimension drawing, and interchange in all re-

gions vertically 10 per cent greater than pressed steel bolsters. Built-up bolsters must be as strong vertically as pressed steel bolsters. All bolsters to have a transverse strength at least 50 per cent of vertical strength.

Center Plates.—(1) Drop forged, or (2) cast steel.

Side Bearings.—See body specifications.

Brake Beams.—Each 40-ton and 50-ton truck to be equipped with two M. C. B. No. 2 brake beams, and each 70-ton truck to be equipped with two M. C. B. No. 3 brake beams, all conforming to limiting outline and general conditions shown on drawing.

Brake Shoes.—To be: (1) With reinforced back, or (2) plain cast iron.

Wheels.—For the 40-ton trucks the wheels are to be M. C. B. standard for cars having axles with 9-in.

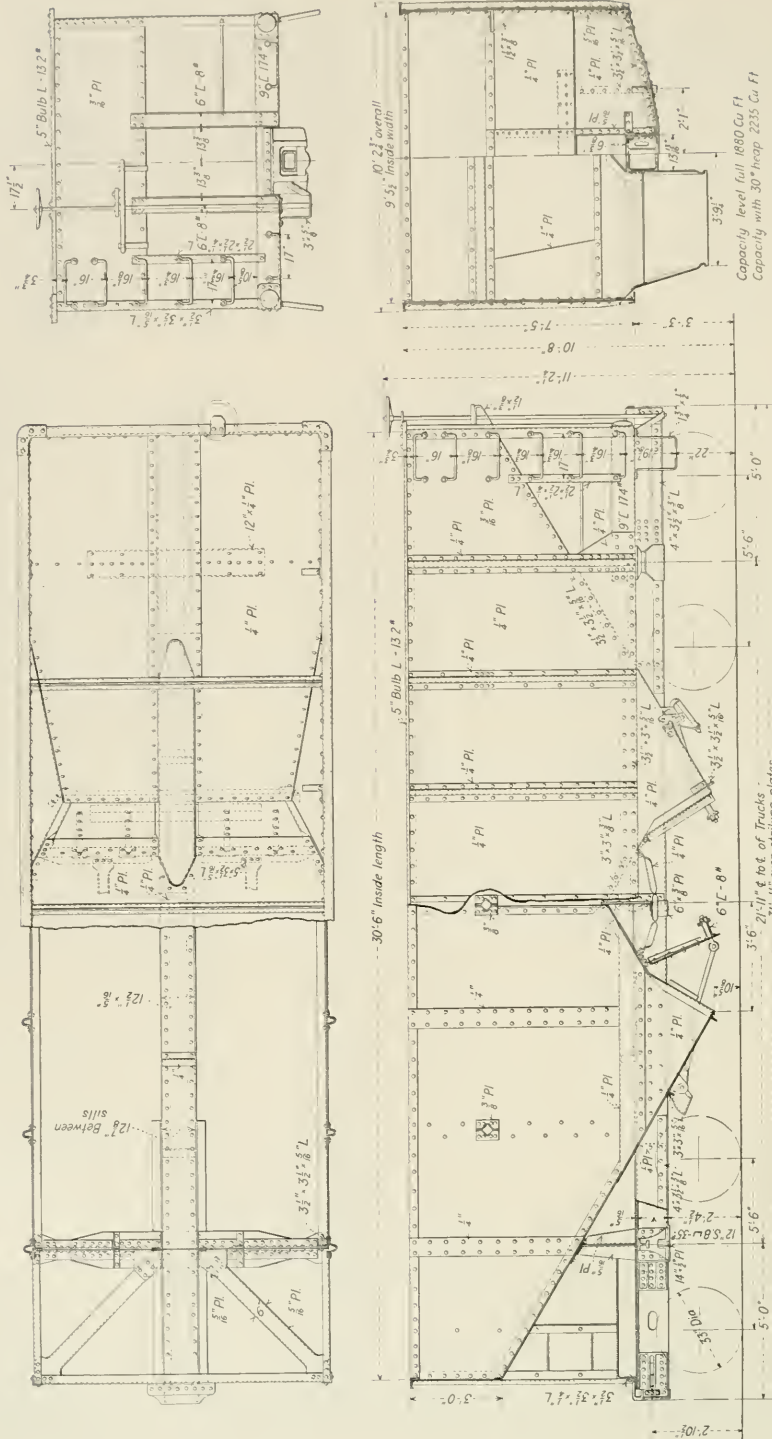

Fig. 17—General Plan of the Standard 55-Ton Hopper Car

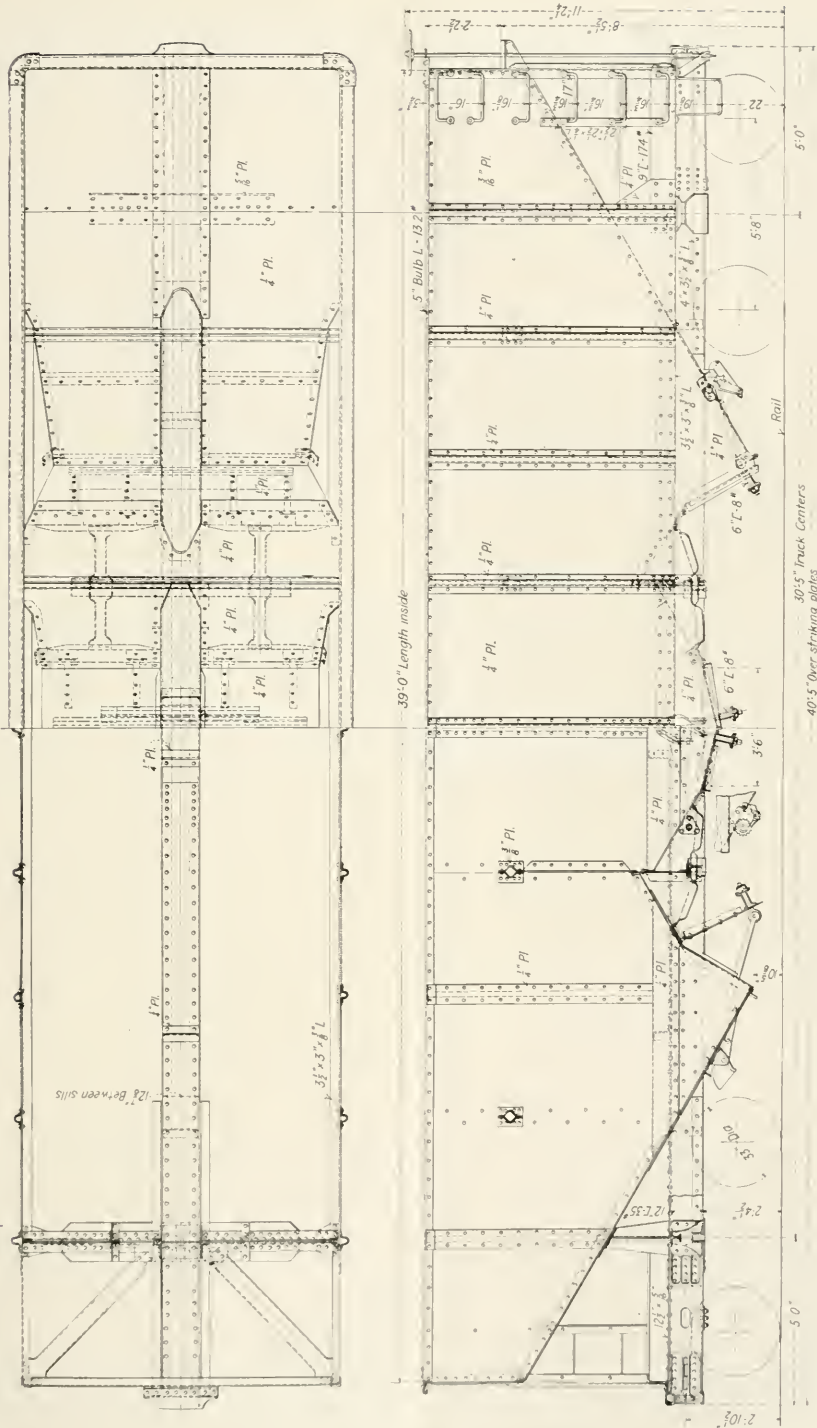

Fig. 18.—General Plan for the Standard 70-Ton Hopper Car

journals. To be cast iron, weighing about 700 lb. each. Wheels to be in accordance with M. C. B. specification, and to be mounted on axles with a pressure of from 40 to 60 tons.

For 55-ton hopper cars, the wheels are to be: (1) wrought steel, (2) cast steel, or (3) cast iron. For all other 50-ton

ard, wrought steel, for cars having axles with 6-in. by 11-in. journals. They are to be in accordance with M. C. B. specifications, and mounted with a pressure of from 70 to 95 tons.

Axles.—To be of open hearth steel, smooth forged or rough turned between wheel seats and journals to be burnished. To

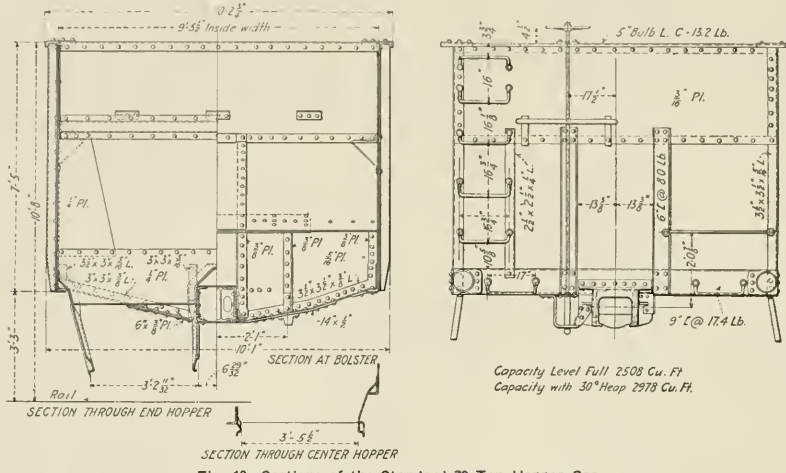

Fig. 19—Sections of the Standard 70-Ton Hopper Car

cars the wheels are to be cast iron. Wheels to be M. C. B. standard for cars having axles with 5 1/2-in. by 10-in. journals. Cast iron wheels to have a nominal weight of 725

lb. each. Cast iron wheels to be mounted on axles with a pressure of from 45 to 65 tons, and steel wheels with a pressure of from 65 to 85 tons.

The wheels for the 70-ton truck are to be M. C. B. stand-

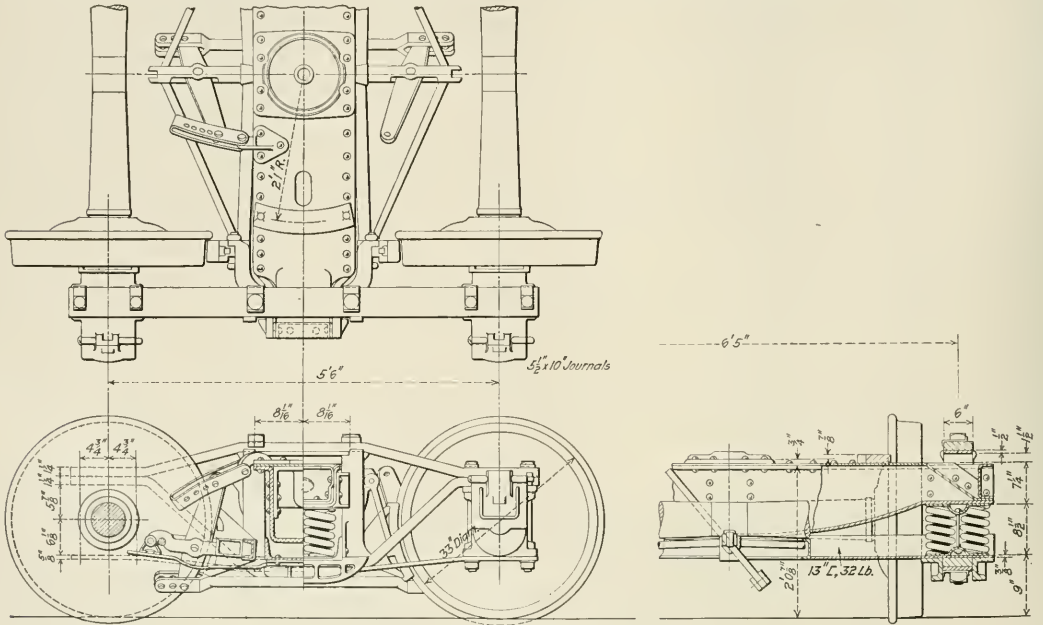

Fig. 20—General Plan of the Standard 50-Ton Truck

lb. each. Cast iron wheels to be mounted on axles with a pressure of from 45 to 65 tons, and steel wheels with a pressure of from 65 to 85 tons.

The wheels for the 70-ton truck are to be M. C. B. stand-

steel, complete with lids and M. C. B. type reinforced wooden dust guards suitable for axles with 5-in. by 9-in. journals, 5 1/2-in. by 10-in. journals, or 6-in. by 11-in. journals, as the case may be. All boxes to be thoroughly cleaned and packed

with journal box packing which has been saturated with freight car lubricating oil.

Journal Bearings.—To be of brass, lead lined, M. C. B specification grade "A."

Journal Bearing Wedges.—To be: (1) drop forged, or (2) cast steel. Wedges to be M. C. B. type, suitable for axles

Painting.—Trucks to receive two coats of carbon black paint. Paints to be in accordance with United States Standard Specification which are shown in the specifications for the car bodies.

The following United States Standard Specifications, for journal box packing and journal box oil, are to apply:

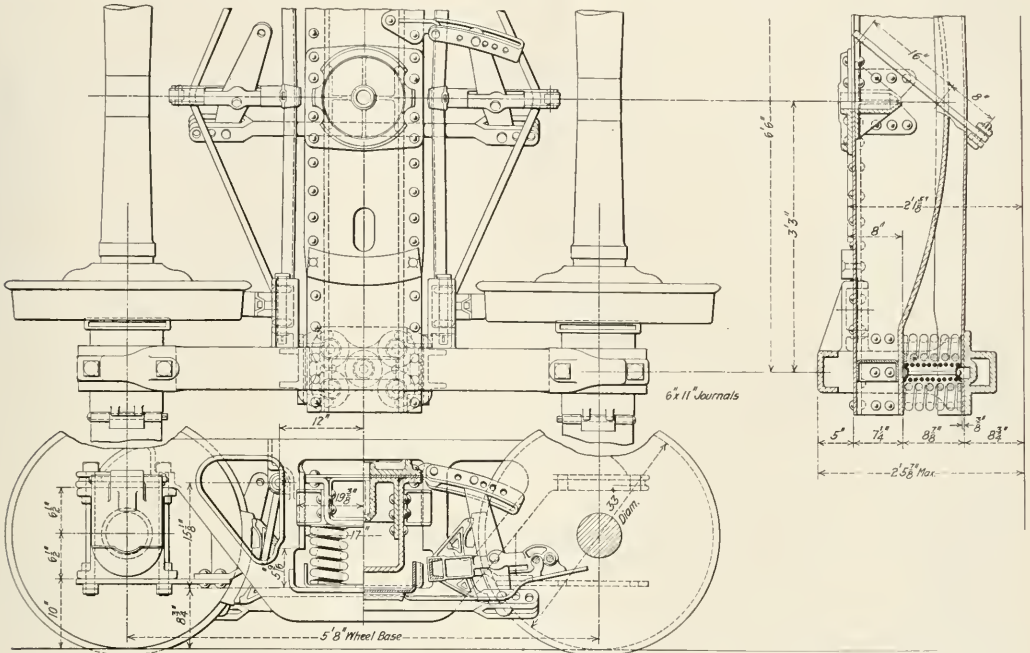

Fig. 21—General Plan of the Standard 70-Ton Truck

with 5-in. by 9-in., 5½-in. by 10-in., or 6-in. by 11-in. journals, as the case may be.

Material Specifications.—The following M. C. B. specifications for materials are to apply:

- | | |
|---------------------------------------|--|
| Axles | Journal bearings |
| Bolts and nuts | Malleable iron castings |
| Boiled linseed oil | Mild steel bars |
| Brake beams | Steel castings |
| Brake shoes | Pressed steel bolsters |
| Carbon steel bars for railway springs | Raw linseed oil |
| Cast iron wheels | Red lead |
| Cast steel bolsters | Rivet steel and rivets |
| Cast steel truck side frames | Structural steel, steel plates and steel sheets for freight equipment cars |
| Steel wheels | Turpentine |
| Helical springs | White lead for lettering |
| Japan drier | Wrought iron bars |

JOURNAL BOX PACKING SPECIFICATIONS

The material desired under these specifications is curled vegetable fiber so curled as to impart to it the maximum resiliency; wool and cotton threads free from large lumps of any one component part and thoroughly machined and intimately mixed with the curled fiber in the following proportions:

- (A)—Vegetable fiber — 20 per cent
- (B)—Wool waste — 40 per cent
- (C)—Cotton waste — 40 per cent

JOURNAL BOX OIL SPECIFICATIONS

The oil required shall be well oil, and will not be accepted if it: (1) flashes from May 1 to October 1, below 298 deg. F., or from October 1 to May 1, below 249 deg. F.; (2) has

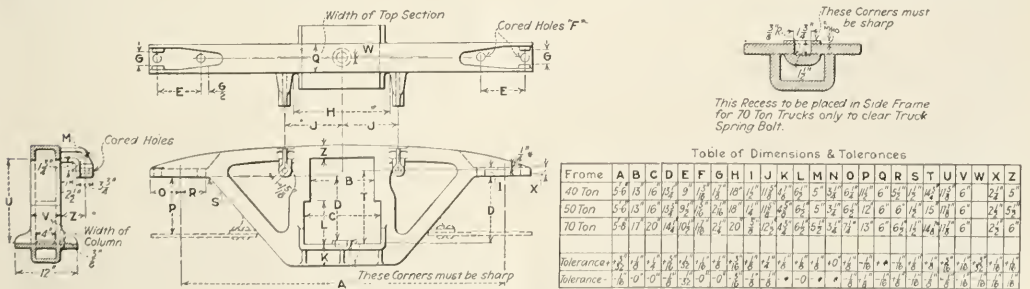

Fig. 22—Limiting Dimensions for the Cast Steel Truck Side Frames

Frame	A	B	C	D	E	F	G	H	I	J	K	L	M	N	O	P	Q	R	S	T	U	V	W	X	Z
40 Ton	5 6	13	16	18 1/2	9	14	11	10 1/2	11 1/2	12 1/2	13 1/2	14 1/2	15 1/2	16 1/2	17 1/2	18 1/2	19 1/2	20 1/2	21 1/2	22 1/2	23 1/2	24 1/2	25 1/2	26 1/2	27 1/2
50 Ton	5 6	13	16	18 1/2	9	14	11	10 1/2	11 1/2	12 1/2	13 1/2	14 1/2	15 1/2	16 1/2	17 1/2	18 1/2	19 1/2	20 1/2	21 1/2	22 1/2	23 1/2	24 1/2	25 1/2	26 1/2	27 1/2
70 Ton	5 6	13	16	18 1/2	9	14	11	10 1/2	11 1/2	12 1/2	13 1/2	14 1/2	15 1/2	16 1/2	17 1/2	18 1/2	19 1/2	20 1/2	21 1/2	22 1/2	23 1/2	24 1/2	25 1/2	26 1/2	27 1/2
Tolerance	± 1/16	± 1/16	± 1/16	± 1/16	± 1/16	± 1/16	± 1/16	± 1/16	± 1/16	± 1/16	± 1/16	± 1/16	± 1/16	± 1/16	± 1/16	± 1/16	± 1/16	± 1/16	± 1/16	± 1/16	± 1/16	± 1/16	± 1/16	± 1/16	± 1/16
Tolerance	± 1/16	± 1/16	± 1/16	± 1/16	± 1/16	± 1/16	± 1/16	± 1/16	± 1/16	± 1/16	± 1/16	± 1/16	± 1/16	± 1/16	± 1/16	± 1/16	± 1/16	± 1/16	± 1/16	± 1/16	± 1/16	± 1/16	± 1/16	± 1/16	± 1/16

* — To Suit

a gravity at 60 deg. F. below 28 deg. or above 31 deg. Beaume; (3) from October 1 to May 1, has a cold test above 10 deg. F., and from May 1 to October 1, has a cold test above 32 deg. F.; (4) shows any precipitation when five cubic centimeters are mixed with 95 cubic centimeters of gasolene.

The precipitation test is to exclude tarry and suspended

illustrations. The 40-ton truck calls for arch bars of 1 1/8-in. material, while the 50-ton truck (Fig. 20) calls for arch bars of 1 1/4-in. material. The 70-ton truck is shown (Fig. 21) with the cast steel side frame, as the arch bar type is not permitted to be used on this truck. The limiting dimensions all side frames must meet is shown in Fig. 22.

The pressed steel bolsters for the 40- and 50-ton trucks

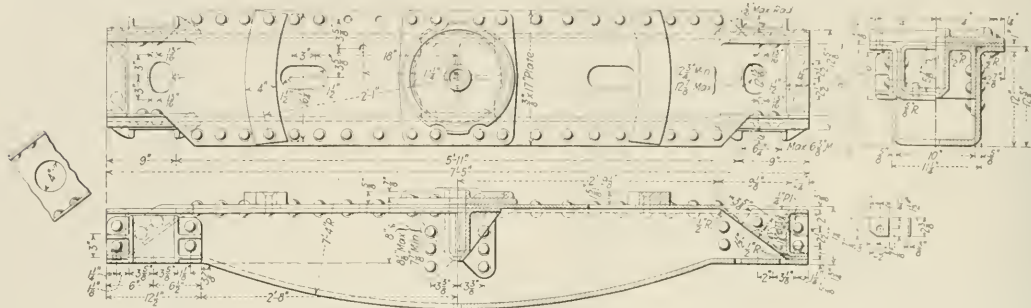

Fig. 23—Pressed Steel Bolster for the Standard 50-Ton Truck

matter. It is made by putting 95 cubic centimeters of 88 deg. B. gasolene, which must not be above 80 deg. F. in temperature, into a 100 cubic centimeter graduate, then adding the prescribed amount of oil and shaking thoroughly. Allow to

are of similar design, the chief difference being in the weight of material used. The 50-ton bolster design is shown in Fig. 23. The bottom plate is 3/8 in. thick in the 50-ton and 1/2 in. thick in the 40-ton. The 70-ton truck bolster,

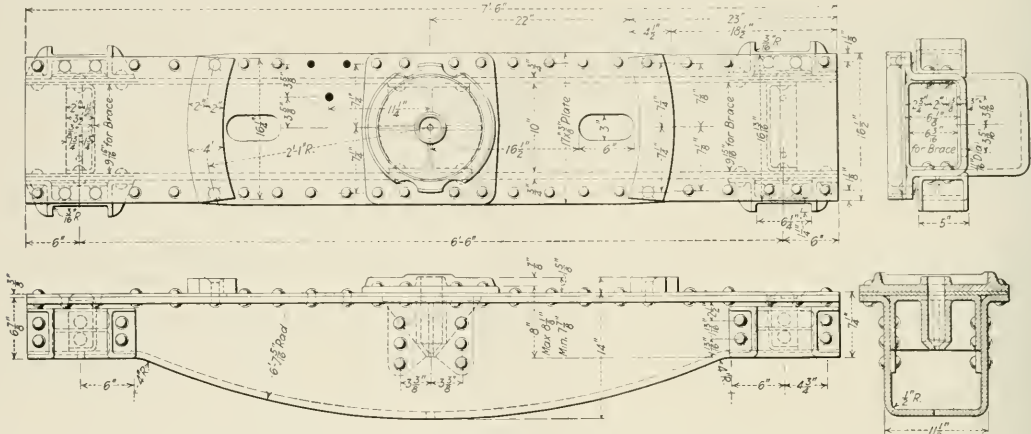

Fig. 24—Pressed Steel Bolster for the Standard 70-Ton Truck

stand 10 minutes. With satisfactory oil no separate or precipitated material can be seen.

There is a marked similarity between the 40- and 50-ton trucks, and for that reason but one has been shown in the

which is shown in Fig. 24, it will be noted, is of somewhat different design. Cast steel and built-up bolsters may be used instead of the pressed steel bolster. All of the brake beams must conform to the limiting outline shown in Fig. 25.

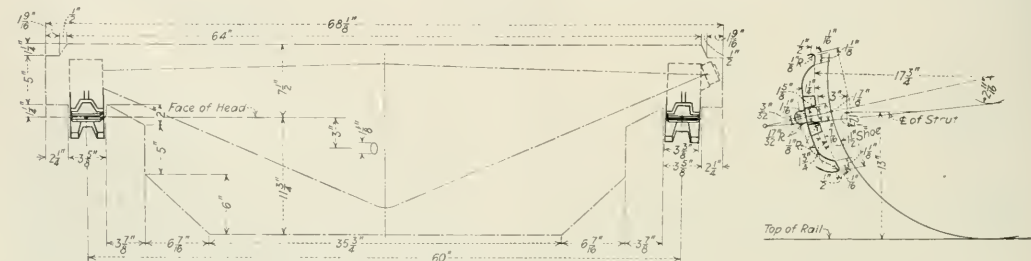

Fig. 25—Limiting Outline for the Standard Brake Beams

MACHINE TOOL EQUIPMENT NEEDED

To Better Meet the Needs in Repairing Locomotives and Cars the Shop Equipment Must Be Improved

DURING the years immediately preceding the outbreak of the European war, the railroads of the United States spent approximately \$12,000,000 annually for shop machinery and tools. In the year 1914 there was a serious falling off in the net operating revenue of the roads, and as a result the expenditures were reduced wherever possible. Consequently only \$9,000,000 was spent for machinery and tools during 1915. Throughout the past two years there has been an unusually strong demand for machine tools for war work and the railroads have confined their purchase principally to tools which were urgently needed. Although no general statistics are available, it is safe to say that the expenditures for tools have been even smaller during the past two years than in 1915. With the great advance in prices, a given expenditure of course represents a much smaller amount of shop equipment. Taking this into account and considering also that the roads are handling far more traffic than ever before, it is quite evident that they are in need of a large number of machine tools at present.

Although there has been no reduction in the prices of machine tools, other changes have taken place which should not be overlooked when considering the advisability of making purchases. The past year has brought large wage increases to all classes of mechanics. While in 1915 the total compensation paid by the roads to mechanics, helpers and apprentices was over \$90,000,000, for the present year it will probably be 40 per cent higher, or about \$125,000,000. There are but few methods that can be used to offset this increase. One that deserves attention is the use of improved machine tools to increase the output per man. Suppose only 2 per cent more output could be secured by providing better tools. Figuring interest and depreciation at the rate of 12 per cent annually this saving would justify the expenditure of more than \$20,000,000. All who are familiar with shop conditions will agree that with improved equipment much greater economies could be effected. Aside from the direct saving in labor there would be opportunities for increasing the efficiency of operation by reducing delays and making it possible to get more service from equipment.

During the past winter it was impossible to care for equipment properly at some points, due largely to the inadequacy of the roundhouse facilities. The machine tool equipment of engine terminals is usually made up of tools that have outlived their usefulness in the shop and should have been sent to the scrap pile instead of to the roundhouse, where time lost in doing the work may result in costly delays.

The need of first-class tool equipment in roundhouses has been recognized for some time. One superintendent of motive power recently stated that he thought with the large locomotives now in use requiring frequent heavy work, every roundhouse should have a few pits equipped for handling heavy repairs in order that the heavy roundhouse jobs could be taken care of promptly. The necessity for keeping down the expenditures has prevented roads from buying the equipment they have required in the engine houses. Better facilities at these points will help to prevent such costly congestion as occurred last winter, and should certainly be provided.

Although the machine tools most urgently needed are those required for roundhouse work, many shops should have additions for their equipment, or replacements for obsolete tools. There are wide variations in the conditions on different roads. Some have followed a consistent policy of

buying shop machinery regularly as additional rolling stock was secured. On other roads the repair facilities are not sufficient to take care of the equipment under the present conditions. It is, of course, advisable to have all locomotives repaired on the home road if possible. While it may not be feasible to build additional shops at this time, the capacity of existing shops is usually limited, not by the number of pits but by the machine facilities and in most cases a few tools, judiciously chosen, will make it possible to increase the output considerably.

The question of providing good repair facilities is of such importance that it should receive first consideration when ordering tools. Under the present conditions, however, the reclamation of materials offers such unusual opportunities for reducing expenses that it may be found advisable to include a considerable amount of machinery in the tool program for such work. As specific instances of equipment that is being reclaimed to good advantage at this time flues, rails and bar iron may be mentioned.

Granting that the roads need a great many machine tools at this time, the question of their ability to secure them naturally suggests itself. There seems to be a general opinion among railroad men that tools of all classes are hard to get and deliveries are very slow. While it is true that in the past there have been delays in securing tools, the situation has improved and reasonable deliveries are now being promised on practically all types of machines.

Before going into the subject more in detail, it may be well to give a short account of the work of the machine tool section of the War Industries Board. Although an advisory body without executive authority, the board has done much good in directing the manufacture and distribution of machine tools. A schedule of production was secured from every shop and from the data furnished it was determined whether the production of various machines was greater or less than the demand. This made it possible to commandeer tools with the minimum of inconvenience to private industries. The requirements of munition plants are being estimated and a reserve of tools set up for such work. Companies which formerly did not manufacture machine tools have been induced to enter the field, thus increasing the production of machines that were badly needed. By preventing speculation in machine tools the board has helped to keep the prices on a reasonable basis. While there has been some costly duplication of facilities, the production and the demand have been controlled as much as possible and the conditions are fast becoming normal.

The commandeering of tools for government work has not interfered with the delivery of tools to railroads to any great extent. Since the roads are now under government control they will probably be given preference in arranging for priority of orders. Some of the tools which the railroads use in large number can now be delivered from stock, and nearly all can be secured within six months from the date ordered. In fact the only classes of equipment on which deliveries are much slower than usual are the extremely heavy tools and special equipment of which small numbers are built.

GOOD DELIVERIES IN MOST CASES

Information received from the manufacturers of tools indicates that the conditions as regards deliveries are at the present time about as follows:

Lathes: A few of the smaller sizes can be delivered from stock. On the larger sizes deliveries vary from two to seven

months, depending on the swing and length of bed. It is almost impossible to secure wheel lathes, as plants equipped to manufacture large tools are devoting all their time to working on government orders.

Turret lathes: All sizes and types can be furnished in from two to five months' time.

Boring mills: With the exception of the larger sizes used for tires and wheel centers, deliveries can be secured in from two to three months. The larger machines are not available at this time and probably cannot be secured for some time to come.

Planers: No class of equipment has been more in demand than large planers. The urgent need for these tools for war work has led to the introduction of a new type of machine which has a concrete base. The medium and smaller sizes can be secured in from four to twelve months, however.

Milling machines: Deliveries of the ordinary sizes of plain and universal milling machines can be made within six to twelve months, while for heavy milling machines the time is somewhat longer.

Shapers: Deliveries vary from four to eight months.

Drill presses: Sizes up to six feet can be secured in from three to eight months; on radial drill presses and on the other types the time required is even shorter.

Cylindrical and surface grinding machines: Small stocks of some sizes are on hand and other machines can be supplied in from two to eight months.

Portable tools: All types and sizes can be furnished within two months from the date ordered.

Electric welding equipment: Deliveries can be made in from one to three months.

Electric motors: All sizes required for driving machine tools can be furnished within two months.

Blacksmith and boiler shop equipment: Steam and power hammers can be supplied in from two to four months, forging machines in six months and bolt machinery in three to five months. Deliveries of punches and shears can be made within one month; flangers are available within four months.

Wood working machinery: Deliveries are practically normal, one to three months being required to fill orders depending on the type of machine wanted.

From the data given above it is evident that while some difficulty might be experienced in securing complete equipment for new shops owing to the great demand for certain types of machines, the ordinary requirements can be met with but little delay. Machine tool prices are stable and there is no longer any thought of postponing buying in anticipation of a possible decrease in prices. The railroads have everything to lose and nothing to gain if they restrict their orders for machine tools. With labor costs continually rising, they have every inducement for replacing the old equipment with modern machine tools. The roads must operate at the highest efficiency in order to handle the present enormous traffic. Better shop equipment will help them to realize that aim. Their purchases in the past three years have been entirely inadequate, but this year the roads should make up for it and should place larger orders for machine tools than during any previous year.

OLD TRACINGS ASKED FOR BY RED CROSS.—The American Red Cross requests manufacturers and others using tracing cloth to donate discarded tracings to the Red Cross. The tracings are washed and the material—linen or cotton—is employed for the making of surgical dressings to be used in the field hospitals. The Red Cross has made arrangements with large laundries in all cities to collect material of this kind, and any organization wishing to aid should call up the local Laundry Owners' Association, or one of the large laundries in his city, who will send for such material as he will give them.

ORGANIZATION MAINTENANCE*

BY A. R. AYERS

Superintendent Motive Power, New York, Chicago & St. Louis

One of the greatest problems before the railroads, as a result of the present intense industrial activity, is that of keeping up their organizations to a point which will accomplish the necessary results. Chief among the factors which make this problem difficult is the constantly changing personnel of the organizations, brought about by officers and foremen as well as workmen leaving railroad service for military or industrial occupations. For many years railroads have been operated by men of long experience in that particular work; the workmen as well as those in supervising capacities were thoroughly familiar with the details, and properly handled most situations as a matter of routine and with very little detailed instruction. This brought about a situation, where the proper handling of a given task was frequently put up to the workman to whom it was assigned with practically no detailed instruction from the man who assigned the work; the workman was supposed to know his business.

Conditions have changed in recent months, and on all the railroads we are doing the work with men who, in many cases, have had no previous railroad experience; this applies to the road work as well as shop work. This condition makes a heavy burden on supervision and it is necessary for supervision to change its methods materially; the work can no longer be put up to the man without instruction. When a man lacks previous experience, or perhaps lacks initiative, it is necessary to instruct him in detail concerning the work which he is to do, and in many cases even supervising officers and foremen, who may be new in their present positions, do not understand very definitely just what is expected of them.

Difficulty in getting results is sometimes ascribed to indifference on the part of the men, and while this may be so in many cases, it is also true that much of the difficulty is due to lack of experience of the men, and lack of proper supervision and instructions. There are many conditions existing in shops and engine houses which were not very strongly objected to by the old timers, who were used to them, but which contribute quite largely to indifference and inefficiency on the part of the new and inexperienced employees. Some of these conditions are, poor light, lack of sufficient heat, poor floors, lack of proper small tools and worn out machinery. Men who are used to working with labor saving devices do not take kindly to places where they have to do the same work by main strength and awkwardness.

There is no question that a much heavier burden has been placed on our supervision, on account of the necessity of giving detailed instructions to new men, which were not required with the older men, and where this has been recognized, and where the supervising force has been organized to meet the conditions, excellent results may be obtained which will more than repay the additional expense.

The continual changing of the working force, requiring the constant educating of new men, requires more than usual courage, resourcefulness, cheerfulness and enthusiasm on the part of the foremen, as well as ability in their particular kind of work. Nothing is more important at this time than to inspire these qualities in the men who are close to the firing line.

In the present emergency, I am prompted to quote from the address of J. F. Deems, when he was president of the American Railway Master Mechanics Association in 1907: "We may work in brass and steel and leave the most perfect mechanism; we may develop and improve and evolve methods and practices until nothing more can be desired; we may

*Abstract of a paper presented before the Western Railway Club.

reach perfection in all these, in mechanism, structure and method, and yet our bequest be a failure and itself a burden unless we provide that which is paramount, which is over and above the sum total of all this, and for which, even today, events throughout the world are crying aloud—the man. A man prepared, experienced, earnest; hopeful and happy; consecrated to his work and ready to the hand of the future." There are many such men in our organizations; some of them we know, others we have not yet discovered, and it is up to us to know that our working conditions in shops and on the road are the best that can be afforded, that our supervision is ample and capable, so that men will understand their duties and will be happy, contented and enthusiastic in the performance of them, in order that nothing may be left undone to give our last ounce of energy in supporting this Government and those who are fighting for us to win this war.

DISCUSSION

The consensus of opinion was that there is need for an increased number of foremen at this time. Less supervision

is required where the piece work system is in effect than where the men are on day work. Some stated that it was impossible to get men to stay on the work long enough to train them. A. R. Kipp (Soo Line) brought out the fact that the workers at this time have not the same spirit as formerly and it will take a different kind of supervision to secure results. As there is a spirit of carelessness and indifference in the workers, the foremen must put in a personal touch to give them inspiration and incentive. T. H. Goodnow (C. & N. W.) expressed the opinion that the seniority rule makes it very difficult to secure foremen and often makes it impossible to get the best men who could be chosen in supervisory positions. The organization and rules of the unions have removed the ambition which workers formerly had. Another difficulty is due to the fact that the majority of men now doing the work in some departments are foreigners. With the shortage of labor and the attitude of the labor organizations it is difficult for the foremen to secure results. The men in the higher positions should uphold the foremen in order that they may secure the support of the men in the ranks.

FREIGHT CAR AND TENDER TRUCK BOLSTERS

An Explanation of the General Principles Involved in the Design, Loading and Testing of Truck Bolsters

BY G. S. CHILES AND R. G. KELLEY

THE decided lack of uniformity in the specified requirements of various railroads regarding the design and testing of truck bolsters for cars and locomotive tenders appears to warrant the following investigation. It is proposed to develop a method of testing such bolsters, especially with regard to the method of loading, which will be more in harmony with the designing practice of the present day. Disregarding such factors as the chemical and physical properties of the steel, annealing, workmanship, finish, marking, weight, test coupons, etc., the question of design will be confined to a consideration of the method of loading, allowable fibre stress, method of testing and the specified deflection and set. As the general principles involved in a specific case are of interest rather than a tabulation of differences for bolsters of various capacities the investigation will be limited to those used under 50-ton freight cars.

The specifications of some railroads call for an allowable, calculated fiber stress for a given vertical and transverse load, and as this is, perhaps, best illustrated by a sample of the usual form of specification, the following examples are submitted. While the requirements for the transverse loads are also included, the discussion which follows will have to do primarily with the vertical requirements:

Example 1—"Bolsters are to be designed for maximum fibre stress not to exceed 10,000 lb. per square inch under a 72,000 lb. vertical load concentrated at the center plate, with supports at centers of spring bearings."

Example 2—"Bolsters must be designed to carry upon the center plate when supported at the spring seats, with an extreme fibre stress of not more than 16,000 lb. per square inch, a static load of 100,000 lb."

Example 3—"Cast steel truck bolsters must be designed for vertical loads delivered at the center plate by the body bolster. This load on each truck bolster is to be taken as one-half of the total load, which is comprised of the sum of the following:

(A)—Light weight of car body above truck bolsters.

(B)—Rated capacity of car plus 10 per cent overload.

(C)—Fifty per cent of the sum of (A) and (B) for impact. Direct stresses due to vertical load must not exceed 15,000 lb. per square inch."

Example 4—"Bolsters are to be calculated by the three following methods, and in no case should the maximum stress exceed 9,000 lb. per square inch.

(A)—Vertically with 73,000-lb. load concentrated on center plate and bolster supported at centers of spring bearings.

(B)—Vertically with 73,000-lb. load concentrated equally on one side bearing and center plate and bolster supported at centers of spring bearings.

(C)—Transversely with a load equal to 50 per cent of vertical load and concentrated at center in transverse direction, with bolster supported at center of column."

It is plainly evident that the specified requirements of Example 2 are equivalent to limiting the fibre stress to 10,000 lb. for a center plate load of 62,500 lb., or to 11,000 lb. for a center plate load of 68,750 lb. For a 73,000-lb. center plate load, the equivalent stress would be 11,190 lb. per square inch.

In the specification cited in Example 3, limiting fibre stress of 15,000 lb. per square inch is specified, based upon a loading which is equal to the sum of the light weight of the car body above the truck bolsters plus the rated capacity of the car increased by 10 per cent, which is usually considered to be the bolster design load, plus an amount equal to 50 per cent of the sum of these two amounts which is added to compensate for impact. A specification drawn up in this form is equivalent to one in which the 50 per cent overload provided for impact is omitted and the limiting value of the fibre stress is specified to be 10,000 lb. per square inch. In fact, this specification is in reality almost identical with the specification quoted in Example 1, with the exception that in the latter case the design load is a specified amount and is not estimated for each individual design of bolster. A design load of 68,500 lb. is quite often specified for a 50-ton capacity truck bolster.

In Example 4, the fibre stress is limited to 9,000 lb. per square inch and the direct vertical load, by which is implied the center plate load, as explained in paragraph (A), is specified to be 73,000 lb. instead of 72,000 lb. as in Example 1. A vertical eccentric loading such as the one described in paragraph (B), in which one-half the total vertical load is assumed to act at the center plate and the balance at either side bearing, requires that the bolster be designed for greater strength near the side bearings, as will

be explained more in detail later on. The transverse load is now quite commonly specified, requiring 50 per cent of the calculated vertical strength, some railroads requiring even higher values, but as the transverse strength or test requirements all specify a load at center only with supports at the centers of the columns, this phase of the subject is not as important and will not be considered at such length as the vertical.

A number of bending moment diagrams for various types of loading are reproduced in Fig. 1. Throughout the article all values of bending moment are expressed in inch pounds. On account of lack of space, the words "inch pounds" or their abbreviation are omitted in the diagrams. The first diagram represents the system of loading provided for in the specification of Example 1 with the exception that a load of 73,000 lb. is used instead of a load of 72,000 lb. As the loads usually specified range from 68,500 lb. to 73,000 lb. for convenience in making comparisons of the different methods a normal load of 73,000 lb. will be used. The second diagram is similar in all respects to the first diagram, with the exception that it is based upon a load equal in amount to but one-half the load, or 36,500 lb. As in the first case, it is assumed to act at the center. In the third diagram also, the load is equal to but one-half the original load, but instead of acting at the center of the bolster, it is assumed to act at the center of the left side bearing or at a distance of 13½ in. from the left support. The fourth diagram represents the system of loading specified in case (B) of the specification of Example 4, which requires that the bolster be designed for a load concentrated equally on the center plate and on one side bearing. It will be readily apparent that this diagram is in reality, the algebraic sum of the second and third diagrams. The fifth diagram of Fig. 1 is the maximum moment diagram for the combined loadings specified in case (A) and case (B) of Example 4, which were shown graphically in the first and fourth diagrams. In designing bolsters to meet the requirements of a specification of the type illustrated in Example 4, the maximum moment as indicated by the lower heavy line in the fifth diagram must be used.

Reference to this line will bring out the fact that the bending moment at the side bearing increases from a value of 492,750 in.-lb. for the case in which the load is concentrated at the center plate, to a value of 652,734 in.-lb. for the case in which one-half the load is assumed to act at the side bearing and the other half at the center plate, or in other words, in the latter case the bending moment at the side bearing is 132 per cent of that resulting from the normal bending moment due to the concentration of the entire load at the center plate. The area of the small triangle readily illustrates the change in the bending moment diagram for a concentrated load acting at the center plate, which is brought about by this assumed double system of loading.

It will be recognized that this diagram is complete but for that half of the load which acts at the left side bearing only. Were the other half of the load assumed to act at the right side bearing and the diagram completed, it would be symmetrical. In working up a bending moment diagram, it is much more convenient to consider but one side only—in fact, by using the value of 246,377 in.-lb., which is shown at the center of the third diagram, it is only necessary to lay out construction lines for one-half the length. This method is followed in diagrams 6 and 7 and the moment diagrams which follow. A diagram is not absolutely essential, but it provides a ready means of ascertaining just what parts of curves 1 and 4 enter into the construction of curve 5. It is absolutely necessary that the maximum value of the moment, whether it be of curve 1 or 4, be used if it is desired that the design meet the requirements of the specification cited in Example 4.

In the first five diagrams of Fig. 1, the spread of the side bearings was assumed to be 50 in., or 4 ft. 2 in. The last diagram of Fig. 1 is in reality two distinct diagrams, each having a different spacing of side bearings—on the left half of the diagram, designated as No. 6, the spread of the side bearings is 60 in., or 5 ft. 0 in., while for the right half of the diagram, designated as No. 7, the side bearings are spaced 64 in., or 5 ft. 4 in. apart. The heavy line indicated by the figures 6 and 7, respectively, defines the maximum bending moment for a system of loading wherein on the one hand one-half of a load of 73,000 lb. acts at the center plate, and the other half acts at the side bearing, and on the other hand, the entire load of 73,000 lb. is concentrated at the center plate. Considering the

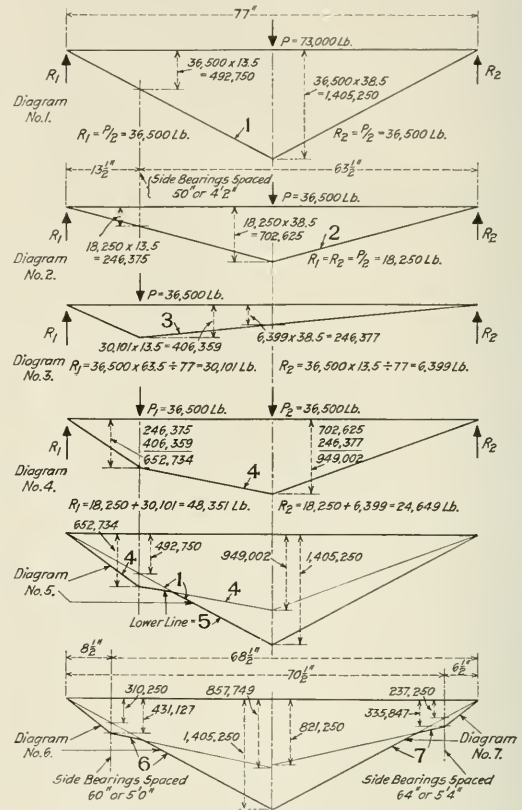

Fig. 1—Seven Bending Moment Diagrams for Varying Bolster Loads

bending moment at the side bearing due to a load concentrated at the center plate as 100 per cent, the bending moment when one-half the load acts at the side bearing and the other half at the center plate attains a value of 139 per cent and 142 per cent for these two cases respectively, whereas it was 132 per cent for the case in which the side bearing spacing was 50 in. or 4 ft. 2 in.

The reason why the maximum bending moment at the side bearings increases in proportion as the spread of the side bearings is increased, becomes readily apparent when we recall the fact that one-half of the total load was assumed to act at either side bearing, irrespective of how far apart they were spaced.

Bending moment diagrams have now been developed for specifications which call for a system of loading wherein the entire load is concentrated at the bolster center plate and also for those specifications which provide that the load shall be concentrated at the center plate or divided equally between the center plate and one side bearing. With respect to the latter case, three different side bearing spacings have been used in order to bring out the effect upon the bending moment due to differences in the spread of the side bearings, and to emphasize this point as regards its effect upon the form of diagrams 5, 6 and 7, and to provide for a ready comparison, all three diagrams have been reproduced in Fig. 2.

Another type of bolster specification is one in which it is required that the bolster shall be designed for a certain

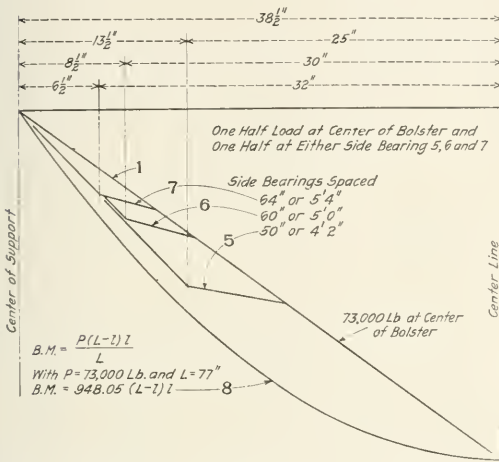

Fig. 2—Combined Bending Moment Diagrams

given section modulus (Z). The formula given in Fig. 3 and developed by W. F. Kiesel, Jr., assistant mechanical engineer of the Pennsylvania, represents an example of this method. Although this formula, in the form in which it is presented does not take into account the spacing of the side bearings, bolsters so designed have a greater relative section modulus near their ends than would be the case were they designed to the first diagram of Fig. 1. This formula as given is based upon a fibre stress at the center of 12,500 lb. per square inch. In order to demonstrate how a bending moment diagram constructed according to this method compares in a general way with the diagrams 1, 5, 6 and 7, the bending moment as called for by this equation is plotted as curve 8 in Fig. 2, the other diagrams being a series of straight lines. It is to be borne in mind, however, that the maximum value of the fibre stress used with diagrams 1, 5, 6 and 7 range from 9,000 to 12,000 lb. per square inch, usually 9,000 or 10,000 for tension and 11,000 or 12,000 for compression being specified, although some specifications provide that the maximum values of tension and compression shall be equal in amount, that is, not over 9,000 for either tension or compression.

In order to provide a ready comparison of all the various methods employed in the design of bolsters, the section moduli as determined from diagrams 1, 5, 6 and 7, based upon a fibre stress of 9,000 lb. per square inch, are plotted in Fig. 3, together with that used in connection with the formula just presented. It is evident that the diagram developed from the formula, in which a value of 12,500 lb. is employed for the fibre stress, approximates very closely

to the requirements at the side bearings of diagrams 5, 6 and 7, but provides for a considerably smaller value of section modulus for that section of the bolster included between its center line and a point located about 24 in. from the support, i. e., it provides for a section modulus of 112.4 at the center of the bolster as compared with 156.0 for either of the diagrams 1, 5, 6 or 7. That portion of the diagrams which is based upon an assumption that one half the load acts at the center plate and the other half at the side bearing, and which gives a smaller section modulus than that resulting from a load concentrated at the center plate, is shown by dotted lines. The greater value of the section modulus corresponding to the maximum bending moment should be used and these values are indicated by the full lines.

It has been quite generally the practice heretofore to employ in the design of bolsters the method outlined in Example 1 and also shown as one in Figs. 2 and 3, but due to the fact that the large percentage of bolster failures occurred in the vicinity of the side bearings or ends, and influenced by the investigations as to the action of the forces, the practice of designing bolsters according to the requirements of specifications such as the one cited in Example 4 and illustrated by diagram 8 of Fig. 2, has in most cases been adopted by designers and one or the other of these two methods is now usually specified.

Assuming a horizontal force equal in amount to 0.4 of the vertical load W to act 72 in. or 6 ft. above the rail, in accordance with the practice followed in designing M. C. B. axles, it is evident that the reaction at the side bearing, due

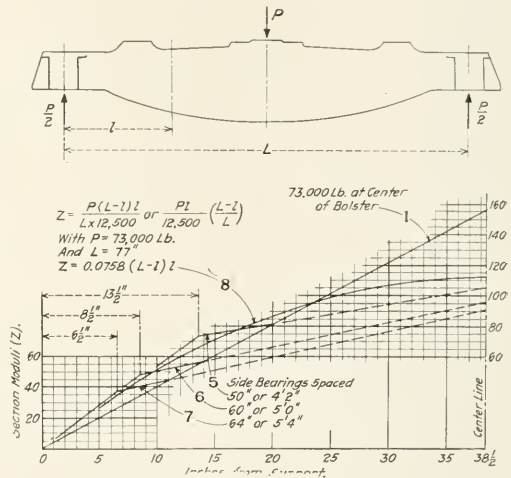

Fig. 3—Section Modulus Curve

to this action, would depend upon the side bearing arm; that is, the distance from the center of the side bearing to center of the bolster. With a center plate bearing located 26 in. above the top of the rail, the arm of the horizontal force would be 72 in. minus 26 in., or 46 in., as compared to a side bearing arm of 25 in., 30 in. and 32 in. for side bearings having a spread of 50 in., 60 in. and 64 in. respectively, as was the case in the diagrams of Fig. 1 and the resultant side bearing reactions in terms of H' would become 0.736 H' , 0.613 H' and 0.575 H' respectively. For a center plate load of H' equal to 73,000 lb., the numerical value of the reactions at the side bearings becomes 53,728 lb., 44,773 lb. and 41,975 lb. These amounts are shown just

above the arrowheads at the location of the side bearings at the left of each of the three diagrams in Fig. 4.

When a load comes on either side bearing due to the action of a horizontal force, there are in addition to the two equal reactions at the bolster spring seats resulting from the 73,000 lb. load at the center bearing, reactions occurring at each spring seat, the maximum reaction due to the side bearing load being at the spring bearing adjacent to the loaded side bearing. In case the side bearing arm is equal to or greater than one-half the distance between the bolster spring seats, the horizontal force might be just sufficient to cause the maximum reaction to equal the tilting force, in which case the other reaction due to this force would equal zero. Any increase in the horizontal force above this amount would cause a negative reaction at the spring seat opposite the loaded side bearing end. However, the spread of the side bearings in all three of our assumed spacings is such as to cause a positive reaction at each spring seat for the action due to the horizontal force alone, irrespective of its amount.

Based upon the same assumption that a horizontal force equal in amount to 0.4 of the vertical load, acting at a point 72 in. above the rail, the bolster reactions, due to the reactions at the side bearing as determined in the preceding paragraph as well as the bolster reactions due to the direct vertical load, are also noted at the lower right and left hand corners of each of the diagrams of Fig. 4. These reactions

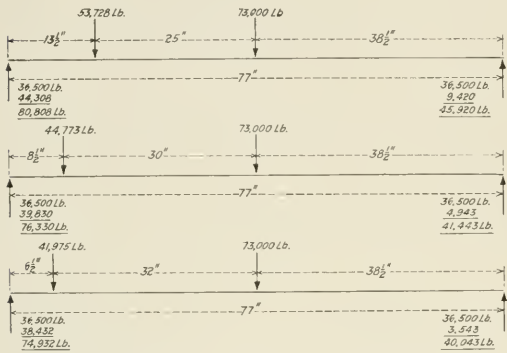

Fig. 4—Diagrams Showing the Reactions Due to Combined Vertical and Horizontal Forces

were determined, of course, by considering the bolster as a single beam supported at the ends, and carrying a single concentrated load. Thus in the group of figures in the lower left hand corner of the upper diagram, the value of 36,500 lb. represents the reaction at the left support due to the concentrated load of 73,000 lb. acting at the center of the bolster, (i. e. center plate load). Similarly, the value of 44,308 lb. represents the reaction at the left support due to a load of 53,728 lb. acting at the left side bearing (i. e. side bearing reaction determined in preceding paragraph) and it is determined by multiplying this load by its moment arm about the right point of support and dividing the sum by the distance between the two points of support, thus:

$$53,728 \times 63.5 \div 77 = 44,308 \text{ lb.}$$

The maximum bolster reaction at the left point of support is equal to the sum of these two reactions or 80,808 lb., an amount which is 221 per cent of the normal reaction of 36,500 lb., due to the direct static load of 73,000 lb. acting at the bolster center plate. Similarly, the maximum bolster reactions at the left for each of the other diagrams will be found to be 76,330 lb. and 74,932 lb., which amounts in terms of per cent of the normal reaction, are 209 per cent and 205 per cent respectively.

The figures at the lower right hand corner of the diagrams represent the bolster reactions at the right point of support corresponding to the bolster reactions at the left point of support as determined above. These reactions at the right point of support are minimum reactions for this condition of loading and will be found to be 12.6 per cent, 11.3 per cent and 110 per cent respectively, of the normal

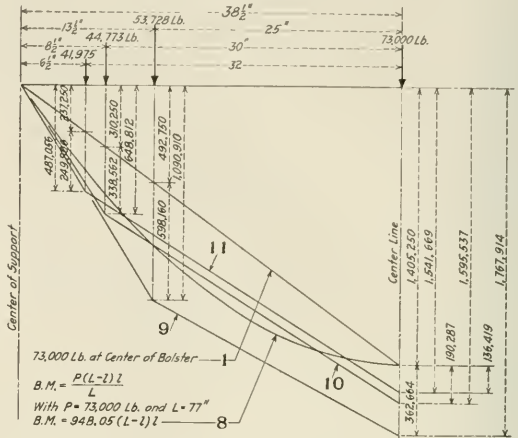

Fig. 5—Diagram of Bending Moments Due to Combined Vertical and Horizontal Forces

reaction of 36,500 lb., due to the direct static load of 73,000 lb. acting at the bolster center plate.

Were the horizontal load assumed to act in the opposite direction, or towards the right, these reactions at the right and left points of support would be merely transformed, i. e., the maximum reaction would occur at the right support and the minimum at the left support. According to the method of loading outlined in Example 4, (A) and (B), and illustrated by the fifth diagram of Fig. 1, the maximum

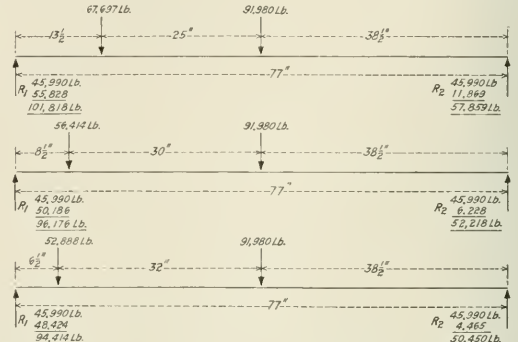

Fig. 6—Diagrams of Reactions Due to Horizontal Forces Plus Vertical Forces Increased 26 Per Cent for Vertical Impact

reaction for the bolster having a spread of side bearings of 50 in. will be found to be 48,351 lb. or 132 per cent of the normal reaction, due to the direct load acting at the center plate, this being the reaction adjacent to the side bearing which carries one-half the vertical load. Were such a condition to actually occur in service, the reaction at the other end of the bolster would be 24,649 lb. or 68 per cent

of the normal reaction, as indicated at the right of diagram 4, Fig. 1 and at the top of Table I. As mentioned above, in designing bolsters according to this method, the process is shortened by making use of a moment diagram similar

under these circumstances to at least 20 per cent more than their designed capacity." As regards the load the axle was designed to carry, they state: "The axle recommended by your committee is therefore designed to carry 31,000 lb.,

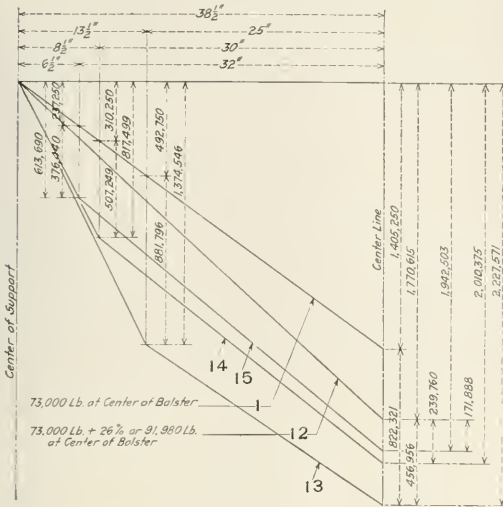

Fig. 7—Bending Moment Diagram With 91980-Lb. Center Plate Load

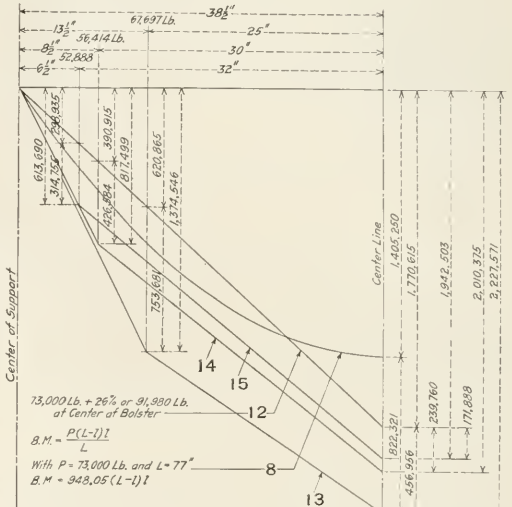

Fig. 8—Bending Moment Diagram With 73000-Lb. Center Plate Load

to that part of diagram 5, Fig. 1 to the left of the center line for both ends of the bolster.

In constructing the bending moment diagrams of Fig. 5, the direct load W acting at the center plate was taken as 73,000 lb. and the horizontal force H assumed to act 72 in. above the rail, equal to $0.4W$ or 29,200 lb. In making their recommendations as to the loads to be employed in the de-

including body, trucks and loading. It should be distinctly understood that the axle recommended is to carry this weight, as the sum of the weights of the car body and trucks and lading when using 33-in. wheels."

In Fig. 5, in addition to the bending moment diagrams 9, 10 and 11, for combined vertical or center bearing load of 73,000 lb. and the horizontal load equal to 0.4 of the

TABLE I.—VERTICAL REACTIONS AT BOLSTER SUPPORTS FOR THREE CONDITIONS OF LOADING. THE TOTAL REACTION AT EACH SUPPORT IS GIVEN IN PER CENT OF THE NORMAL REACTION OF 36,500 LB.

Line No.	Amount and method of loading	SIDE BEARING SPACING					
		50 in. or 4 ft. 2 in.		60 in. or 5 ft. 0 in.		64 in. or 5 ft. 4 in.	
		Maximum	Minimum	Maximum	Minimum	Maximum	Minimum
1	73,000 lb. load vertical $\frac{1}{2}$ at center and $\frac{1}{4}$ at either side bearing	48,351 lb.	24,649 lb.	50,721 lb.	25,279 lb.	51,669 lb.	21,331 lb.
2	73,000 lb. load vertical with horizontal load = .4 of vertical or 29,200 lb.	132 per cent	68 per cent	139 per cent	61 per cent	142 per cent	58 per cent
3	73,000 lb. + 26 per cent, or 91,980 lb. vertical with horizontal load = .4 of vertical or 36,792 lb.	221 per cent	126 per cent	209 per cent	114 per cent	205 per cent	110 per cent
		101,818 lb.	57,859 lb.	96,176 lb.	52,218 lb.	94,414 lb.	50,450 lb.
		279 per cent	159 per cent	263 per cent	143 per cent	259 per cent	138 per cent

TABLE II.—COMPARISON OF BENDING MOMENTS AT SIDE BEARINGS AND CENTER FOR VARIOUS LOADINGS. ALL VALUES GIVEN IN PER CENT OF NORMAL BENDING MOMENT OR THAT DUE TO A CENTRAL LOAD OF 73,000 LB.

Line No.	Amount and method of loading	SIDE BEARING SPACING					
		50 in. or 4 ft. 2 in.		60 in. or 5 ft. 0 in.		64 in. or 5 ft. 4 in.	
		Side bearing	Center	Side bearing	Center	Side bearing	Center
1	73,000 lb. at center or one-half at center and one-half at either side bearing	132 per cent	None	139 per cent	None	142 per cent	None
2	73,000 lb. at center with horizontal force = .4 of vertical or 29,200 pounds	221 per cent	126 per cent	209 per cent	114 per cent	205 per cent	110 per cent
3	73,000 lb. + 26 per cent or 91,980 lb. at center with horizontal force = .4 of vertical or 36,792 lb.	279 per cent	159 per cent	263 per cent	143 per cent	259 per cent	138 per cent

sign of axles, the Master Car Builders Association committee (see proceedings of 1896) determined the weight W by adding to the weight of the car body, trucks and lading, 10 per cent additional lading for refrigerator cars and 20 per cent additional lading for gondola cars, the weight of the wheels and axles not entering into the calculation. In regard to the per cent overload recommended the report stated: "The usual overload is 10 per cent, but there are cases where bulky material, such as coal and iron ore, when loaded in cars, is not evenly distributed between the two trucks; and cases are known where trucks have been loaded

vertical load, diagram 1 is also drawn for the 73,000-lb. vertical center load.

The bending moment curve as adopted from the formula of Fig. 3 is represented by diagram 8. The forces at the three side bearing spacings, viz., 53,728 lb., 44,773 lb. and 41,975 lb. respectively, are indicated on the drawing, but it should be borne in mind that only one of these applies to each diagram, the three being shown merely to give a convenient comparison. The increase in bending moment at the side bearing and at the center for the 0.4 horizontal force as compared to the vertical central load of 73,000 lb.,

is denoted in Fig. 5 and tabulated in Table II, line 2. In Table I, the reactions, for this loading, are given in line 2 for the three side bearing spacings and also in per cents of the normal reaction of 36,500 lb.

In Figs. 7 and 8, a series of bending moment diagrams are plotted in accordance with the same method of loading used in laying out the diagrams of Fig. 5, with the exception that the original assumed center plate load of 73,000 lb. was increased 26 per cent or 18,980 lb. in order to compensate for vertical impact, thus making the center plate load 91,980 lb. The value of the horizontal force is assumed to be equal to 0.4 of the center plate load as before, consequently it has been increased in amount in proportion to the center plate load. The numerical value of the various loads and reactions for these diagrams are listed in Fig. 6, diagrams 12, 13, 14 and 15 are reproduced in both Figs. 7 and 8.

In Fig. 7, the first diagram of Fig. 1, which is the bending moment diagram for a single concentrated load of 73,000 lb. acting at the bolster center plate, is reproduced (see diagram marked 1) in order that it might readily be compared with diagrams 13, 14 and 15, which are the bending moment diagrams for the three locations of side bearings based upon a center plate load of 91,980 lb. together with the horizontal load equal to .4H. The bending moment diagram (see diagram marked 12) for a single concentrated load of 91,980 lb. acting at the center plate is also included in Fig. 7.

In Fig. 8 these three diagrams for the various bearing spacings are reproduced in order to compare them with the bending moment diagram drawn in for the 91,980 lb. central load. The bending moment (curve 8) for the formula of Fig. 3 is also reproduced in Fig. 8 for convenience in drawing comparisons.

The vertical reactions at the bolster supports due to this center plate load of 91,980 lb. are tabulated in line 3 of Table I, for each of the three locations of side bearings. Corresponding bending moments in percentage of the normal bending moment or that due to the original assumed center plate load of 73,000 lb. are tabulated in line 3 of Table II.

(To be continued.)

A NEW SPRINKLER ARRANGEMENT

To overcome the inconvenience caused by coal dust, it is common practice to wet down the coal on a tender by means of a sprinkler hose piped to the injector or delivery pipe and when the injector is working, the fireman can use the hose to throw a stream of water back over the tender. The objection to this method lies in the danger of scalding the fireman and a simple way of preventing such

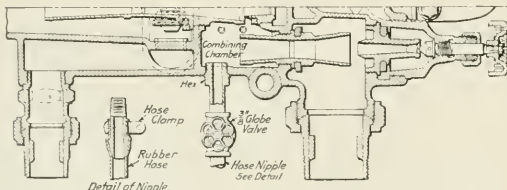

Water for the Sprinkler Hose Supplied from the Injector Combining Chamber

accidents has been suggested and applied to Boston & Maine locomotives. Obviously, if the sprinkler hose is piped to the forcer combining chamber or delivery pipe, it can supply only hot water and steam at the temperature at which it

enters the boiler. If, on the other hand, it is piped to the lifter combining chamber, where the water has just come from the tank, comparatively cool water will be supplied and this is the arrangement recommended by the Boston & Maine.

The accompanying illustration shows the position of the lifter combining chamber with the hose nipple tapped into it. The globe valve and hose clamp are also shown.

In some inspirators there is a $\frac{3}{8}$ -in. clean out plug tapped into the lifter combining chamber and in this case it is very simple to remove the plug and screw in the hose nipple. In case there is no clean out plug, it is simple necessary to drill the inspirator through the lifter combining chamber wall and tap out the hole with a $\frac{3}{8}$ -in. pipe tap.

To operate the sprinkler, the globe valve is opened and the inspirator handle pulled back to the priming position. The water is thereby forced out through the sprinkler connection with velocity enough to throw it 25 or 30 ft. There is some waste at the overflow, but not in sufficient quantity to be considered. Owing to the small volume of steam required to lift the water, the temperature is not raised much above 100 deg. F., thereby preventing scalding accidents. This arrangement cannot be applied to inspirators which do not have the combining chamber feature.

BACK UP THE BOYS AT THE FRONT BY WORK!*

BY S. SKIDMORE

General Foreman Car Repairs, Big Four, Cincinnati, Ohio

Listening to some of the remarks in regard to what the railroads are doing and should do to help win this war, a serious thought has come to me. I see a great many troop trains passing by, with the flower of this country, carrying them we don't know where, going to do their bit—even sacrifice their lives for this country if necessary, and then I have some doubts we stay-at-homes are doing our duty to help win the war.

We all know it is going to take an enormous amount of supplies to win this war, as well as men. I pick up the paper and almost daily I see where the stay-at-homes are going to cut down the production by working shorter hours, I don't know whether it is intentional or not, but they are advocating shorter hours continually, when at this time they should be working longer hours and giving more production instead of less.

It is not the proper time to advocate a less production and less hours work. We should be working more hours, producing everything we can to win this war.

We are all handing out our bit and we stay-at-homes should do that without stint instead of trying to give as little as possible and get out of it all possible. It is the wrong time to advocate the eight-hour principle.

If we had an over-supply of labor it would be all right, but we find now that the labor supply is very scarce. I think if the stay-at-homes would just stop advocating shorter hours until the war is over then they would help save all of our friends in the trenches. No one should object to doing that when we see our fellow-workers giving up their all to fight our battles.

SALE OF BORINGS AND TURNINGS BY SOUTHERN PACIFIC.—The Southern Pacific reports that \$22,000 worth of borings and turnings from machine tools were collected and sold from its shops in 1917, yielding about \$1,900 a month. Over a million dollars' worth of scrap materials of all kinds were sold on the Pacific system in 1917 and a much larger amount was reclaimed for new uses.

*Taken from the proceedings of the Cincinnati Railway Club.



SHOP PRACTICE



FIREBOX REPAIRS*

BY GEORGE AUSTIN

General Inspector Boilers, Atchison, Topeka & Santa Fe

Acetylene and electric welding are rapidly bringing about a complete revolution in firebox repairs. Either process has its own particular field to which it seems better adapted than others, though with either process a good operator will weld anything in a firebox. There is no trouble with half or whole sheets or small parts when contraction is amply provided for. When firebox patches are to be applied on parts where the elastic limit of the plate has been reached, which is indicated by small cracks near the patch being applied, do not weld them; a patch bolt patch leaves no con-

line of side or door sheets should be emergency or round-house jobs only. Conditions and experience will finally govern.

Piecing flues by the electric butt welding process is very attractive, because the flue is not wasted near or at the weld, in fact it is thicker. Second: there is no smoke or noise from welding fires, or trouble with bricking up furnaces. There is no heat used except when taking the heat and that is about twenty seconds to each flue. The process promises to become the standard method of piecing flues. We have about 200,000 of these welds in service and flue failures on account of bursting are not increasing.

Until some method is found that will keep the flue end clean and free from scale accumulation or some tool devised for knocking it off without disturbing the weld, welded flues

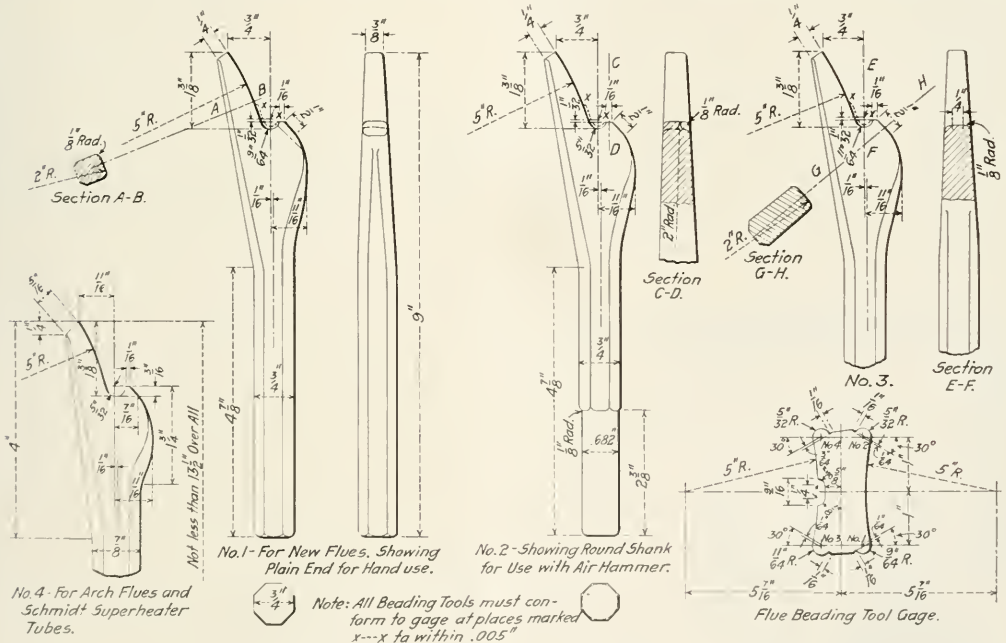

Fig. 1—Standard Flue Beading Tools and Gage for the Atchison, Topeka & Santa Fe

traction strains; it will need to be worked at times, but, will not cause a failure. Welding transverse cracks in the top flanges of back flue sheets has not been reliable. Welding side and door sheet cracks has been disappointing, except as a quick repair job. It may be that we will improve pre-ent methods, but at this time a strict regard for high standards and to prevent failures and the necessity of repairs, demands that welding patches and cracks in the fire-

in the back sheet will be disappointing. Where feed water carries considerable incrusting matter, the scale will form regardless of how the flue is applied and overheating is certain to follow and the weld or flue will break.

WORKING FLUES

Flue beads should be maintained small and compact, free from burrs of surplus metal, for the reason that excess metal exposed to the heat of a firebox absorbs heat in proportion

*From a paper presented before Western Railway Club.

to its area and bulk, and gets out of harmony with the other parts. The Santa Fe system of flue beading tools consists of four sizes, three for small flues, numbered 1, 2 and 3 and one larger size for superheater tubes, numbered 4. These tools come to us from the manufacturer drop forged and finished to gage with the gage number stamped in the side of each. All tools are repaired at Topeka shops; there is no exception to this. The flue beading tools and gage with dimensions of same, standard on the Santa Fe, are shown in Fig. 1. When flue beads get large for a No. 3 tool they are trimmed back to a No. 2. Every reasonable effort is made by the inspectors to keep these tools strictly to gage, and where this is done properly the flue beads will be kept small and compact.

Referring to incrustation on flues, staybolts and firebox sheets, the best tool for removing it from the flues at the sheet is the sectional or prosser expander. For setting flues when applying them we use sectional expanders from B. 9/16-in. deep for 1/2-in. sheet. For hot work or reworking after flues have been beaded, we use a 1/2-in. expander for a 1/2-in. sheet. This keeps the prosser groove hugging the sheet. We use a 3 1/2-lb. hammer on hot work. We do not encourage the smooth type of expander and have very few in use. The prosser expander has been mentioned as being the best tool to jar the scale from the end of the flue on the water side. The objection to its use, is that it stretches the flue holes and distorts the flue sheet. Some light knocking tool should be designed that will work in the prosser groove and part of the flue in the flue sheet and not disturb the outside bead. In order to prevent breaking or splitting the flue at the prosser groove or breaking the bead or welded joint, the flue in the sheet will have to receive part of the blow. We help out large superheater tubes which in hard service give trouble, by applying a 3/16-in. or 1/4-in. by 4-in. wide thimble of the diameter of the flue made from scrap steel or sheet iron. It is not welded. It is set with the butt joint at the bottom and held in place with a flat wedge of 12 or 16-in. gage iron driven between the flue and thimble at the top. The thimble absorbs some of the heat the flue end would otherwise get and relieves it from overheating to that extent. When one end of this thimble burns off, it can be reversed. It is believed welding

the flues to the back sheet will be an improvement on that practice, but until we are fully equipped for welding, we are getting some help from applying these thimbles. With the above mentioned exception, superheater tubes are worked according to instructions recommended by the superheater manufacturers.

CLOSE QUARTER DRIVE AND OLD MAN

BY E. A. M.

The following description refers to a device used in reaming holes in close quarters at right angles, such as guide bolt holes, saddle bolt holes, etc. It was made in one of the large eastern railway repair shops and has given good satisfaction.

Referring to the illustration, 1 is the main casting, of which two views are shown. This casting has holes drilled at right angles to take the bushings 2 and 3, which are made of bronze. The driving shank 4, is a solid piece of steel machined at one end to make the bevel gear shown, and with

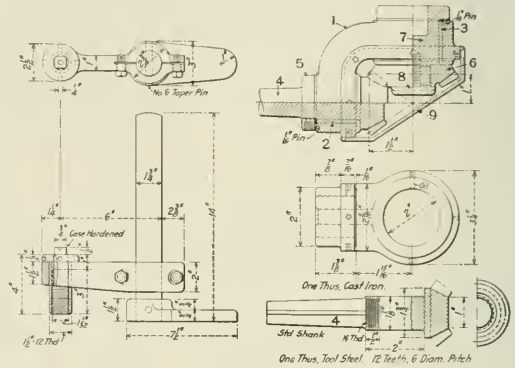

Device Used in Reaming Holes at Right Angles

the other end made into a standard shank to suit the air motor. The driving shank is a running fit in the bushing 2 and is held in place by the nut 5. A fibre washer goes between the shank and the casting and is pinned as indicated to keep it from turning.

The bevel gear 6, which meshes with the driving shank gear is drilled and tapped to receive the reamer socket 7 and another fibre washer is placed between the socket and the casting.

The round head, left-handed set screw 8 screws into the reamer socket 7 and is tightened by means of a slot in the head. It is for the purpose of preventing the gear 6 from unscrewing, which would happen if the reamer got stuck and the motor was reversed.

Finally, to prevent the operator from catching his fingers in the gears, the guard 9 is fastened over them by means of 3/16-in. machine screws. Two oil holes are provided to insure proper lubrication.

In practice, the use of this close quarter drive has made it possible to ream many holes which otherwise would have had to be reamed by hand.

OLD MAN

In connection with the close quarter drive just described, an old man was developed which is also shown in the illustration. Its construction is evident and it serves the purpose of slowly forcing the reamer into the hole, being much better than the old way of using a plank and blocking on the engine frame or boiler.



SHOP SCHEDULING ON THE B. R. & P.

Output of the Shop Has Been Materially Increased and the Burdens of Supervision Have Been Reduced

NO better example of what a shop scheduling system can do in increasing the output of a shop can be found than on the Buffalo, Rochester & Pittsburgh. For the five months following the installation of this system at the Du Bois (Pa.) shops, the output was increased 25 per cent over the corresponding five months in the previous year and during this period 16 new fireboxes were applied as compared to 11 in 1916. This indicates that the work performed during 1917 was

shop scheduling system had been put into effect, 102 locomotives were repaired, each locomotive being held in the shop an average of 25.4 days, making a total of 2,591 engine days. These figures show that while 22 more locomotives were repaired under the shop scheduling system during the five months, there was a decrease of 505 engine days for engines held during that period. With locomotives worth at the present time \$50 per day, this means a saving of \$25,250 in the value of locomotives, and in addition to this 22 more locomotives were put through the hops. With the shop scheduling system it was possible to put the locomotives through the shop faster and with less delay, with the result that where an average number of approximately 27 locomotives were in shop in the five months in 1916, an average of only nineteen were in the shop during the corresponding five months in 1917.

A shop scheduling system permits of definitely laying out the work to be done on each locomotive well in advance of its going to the shop, of ordering and securing the material for the repairs, of fixing the time when each part of the work to be done on the locomotive should be completed and of arranging with each department for the completion of that work so there will be no delay between any of the various steps. Where this is done properly, each operation will be performed in logical sequence, which is particularly necessary in any railway shop. The figures above show what can be accomplished where such definite plans are laid. To put locomotives through a repair shop without a definite plan and schedule is like starting trains out of a terminal without despatching, train rules, orders or signals.

With no definite system in a shop a locomotive is often

BUFFALO, ROCHESTER & PITTSBURGH RAILWAY COMPANY					
MAINTENANCE OF EQUIPMENT DEPARTMENT					
SCHEDULE FOR LOCOMOTIVE REPAIR WORK AT DU BOIS SHOPS					
Engine No.	Class of Repairs	Assigned to Foreman			
GENERAL	WHEELS	BLACKSMITH SHOP - CONT.	WHEELS	ACTUAL	ACTUAL
	REPAIR	REPAIR	REPAIR	DATE	DATE
Engine in Shop		Spang rigging to machaw shop			
" oil wheels		Brake			
Wheels to machines		Tank forgings to smith shop			
Engines arrived		" " " " tank shop			
Jacks and Lagging removed over stay bolts		Frame binders closed			
Final inspection					
All material ordered		ERECTING SHOP			
New parts delivered to shop		Superheater units removed			
Parts to cleaning, varn and returned		" applied			
Frame, Wheels, etc., cleaned		Frames applied and bolting completed			
		Frame binders refitted			
BOILER AND TANK SHOP					
Boiler to boiler shop		Boiler lagged			
Flues to flue shop		Jacket applied			
" applied to boiler		Steam and dry pipes completed			
Fire box work completed		Superheaters work completed			
Boiler ready for hydraulic test		Cylinders work completed			
Boiler returned to erecting shop		Valves applied complete			
Ash pan completed		Flanges			
Gears applied		Gaskets and combafit up			
Smoke box fasteners completed		Air pump, reservoir and air cylinders applied			
Tank to tank shop		Shoes and wedges fast and sent to machine			
Tank covers completed		Spang rigging applied			
Tank ready		Riveting heads up			
		Cab on and floor applied			
MACHINE SHOP					
Wheels ready for test on tires and hub laces		Cab work completed and ready for test			
Driving boxes to machines		Driving boxes spotted on journals			
" box brasses to machine		Engine and trailer truck work completed			
" pins and bolts					
" boxes ready for engine		Engine wheeled			
Shoes and wedges placed to marks		Shoes welded and binders up			
Rocker boxes refitted		Motors work erected			
Spang rigging on flues		Valves set			
Brake rigging on floor		Roads completed			
Valves and pistons to machines		Rails applied			
Flanges		Brake rigging up			
Combafit and guides to machines		Hand rails up			
Guides ready for engine		Pipe work completed			
Combafit ready for engine		Lubricating equipment applied complete			
Excavate straps to machine		Stoker repaired and applied			
		Front end and door on			
		Pillar beam and pillar applied			
		Couplers, buffers, steps and grab-irons applied			
		Engine painted			
		Engine and tender out and coupled			
		Engine fired			
		Safety valve set			
		Air and steam heat completed and tested			
		Engine broken in or white loaded			

Fig. 1—Schedule for the Locomotive Repair Work

considerably heavier than that during the corresponding period in 1916. Further, the work was done with less than a five per cent increase in the total forces and in spite of the fact that approximately 80 trained men were lost on account of the draft and their places filled with men and women of lesser skill. In addition to this the system, together with action which prevented crowding the shop with locomotives, made it possible to decrease the average number of working days per locomotive by over 30 per cent. This of itself is a very important factor, particularly at this time when locomotives are so much in demand.

During the five months period in 1916 referred to above, before the shop scheduling system was put into effect, 80 locomotives were repaired, each locomotive being held in the shop, an average of 38.7 days, making a total of 3,096 locomotive days. During the same months in 1917, after the

BUFFALO, ROCHESTER & PITTSBURGH RAILWAY CO.

Du Bois, Pa., _____ 19__

EXPLANATION OF SHOP DELAYS

Eng.	Class repairs	Date Out	Operation	Date scheduled	Will be completed	Cause of delay

NOTE: Every operation not completed on date scheduled on Planning Sheet must be reported at once on this form to the Shop Superintendent, with detailed explanation of cause of failure.

Despatcher.

Fig. 2—Form Showing Cause for Delays

stripped before some of the necessary material is ordered. The locomotive is tied up while such new material is secured and prepared for application. It is impossible to properly plan for labor requirements and these are constantly being changed to the detriment of the various departments. The foreman and the general foreman have a great burden in that they act more or less as a clearing house and are constantly going from one department to another, as the occasion demands. There is a general lack of co-ordination between the different departments through no fault of their own perhaps,

but simply because without some plan or system their work will become congested.

Where a definite plan or system is followed, the shop is well advised as to the repairs to be made on the locomotive before it comes to the shop, arrangements are made in advance with the different departments for the work to be done, a date is set on which each sub-division of the work should be completed and the plans are so arranged that before the repairs are started on the locomotive it is seen that there will be no conflict with work to be done for other locomotives.

The system used on the B. R. & P., while not elaborate, is well defined. It was installed under the direction of H. C. Woodbridge, assistant to the general manager of that road. From four to six weeks before a locomotive is to be shopped, the local master mechanic or shop superintendent and road foremen of engines are required to advise the shop at which the repairs to the locomotives are to be made concerning the work which, so far as they know, will be required on the locomotive, directing attention particularly to such repairs as will require new material or machining, or extensive boiler work, etc. This report is given to the scheduling supervisor, who keeps a record of the date the new material is requisitioned from the stores department and adds to it the reports made by the locomotive inspectors as a locomotive reaches a shop.

For this work he has a large form ruled into small squares, the vertical columns representing the days of the month and the horizontal columns representing the different items shown in Fig. 1. By means of this form it is possible for the despatching supervisor to so plan the work of the shop that no one department will become congested. For instance,

the various parts shall be completed, a schedule for the repair work is made out for each engine on the form shown in Fig. 1, on which is shown the date on which a particular

BUFFALO, ROCHESTER & PITTSBURGH RAILWAY COMPANY
Maintenance of Equipment Department.

Du Bois, Pa. _____ 19__

Mr. J.A. Morrow,
Division Storekeeper.

Dear Sir:

Below please find list of material required in shop and not on hand, this date.

Eng. No.	Material	Number Requested	Pattern Number

Scheduling Supervisor

Copy to General Storekeeper.

Fig. 3—Form for Following Up Material Shortage

job is to be finished. This form is given to the various foremen throughout the shop.

It is the duty of the scheduling supervisor to follow the

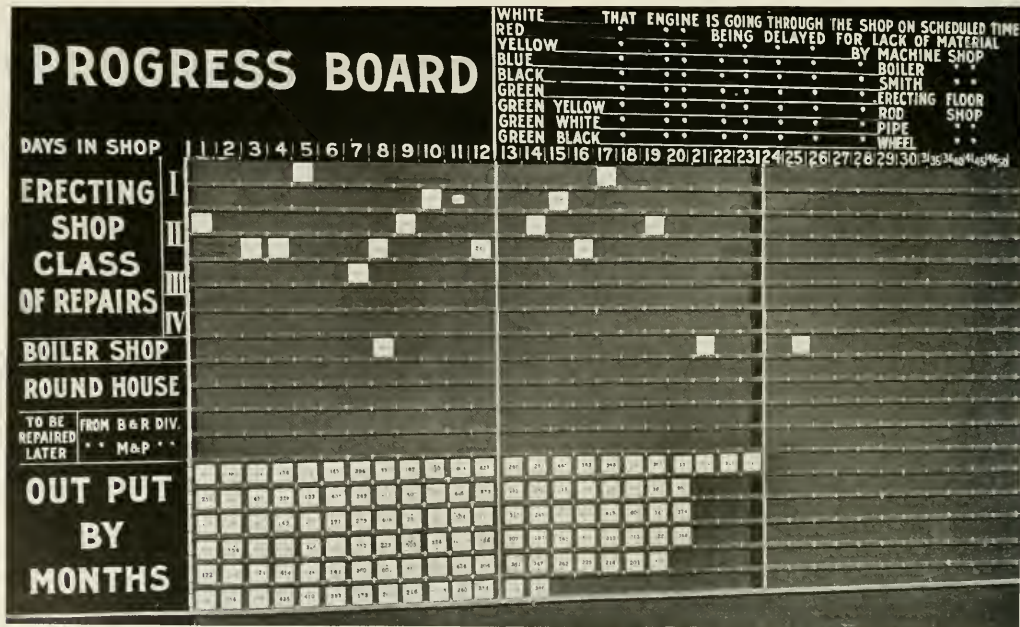

Fig. 4—Progress Board Showing the Condition of the Shop Work

this form may indicate that two locomotives are to be wheeled on the tenth day of the month. The scheduling supervisor will, therefore, not schedule another engine to be wheeled on that day. This plan is followed on all of the principal operations. Having thus determined upon the dates for which

work through the shop carefully and at the end of each day he checks up the work with the schedule, and when the work is done he fills in the date in the "actual day" column on his copy of the form referred to above. In case the work is not done according to schedule, a report is made to the shop

superintendent with a detailed explanation of the cause of the delay on another form shown in Fig. 2, together with the information as to when the work will be completed. In this way the shop superintendent has a definite check on the work going through the shop and is thus advised definitely each day as to just what details require immediate attention in order that work may progress as planned.

The scheduling supervisor also watches closely the material required for repairs and is in constant touch with the local storekeeper. Another form, shown in Fig. 3, is filled out each day showing the material that should be in the shop, but which has not arrived. This is sent to the division storekeeper and a copy to the general storekeeper. This brings to the attention of the stores department the material that is urgently needed and gives them an opportunity of concentrating on it so that the output of the shop will not be interfered with. Such a system has worked to very good advantage at the Du Bois shops and the stores department is very anxious to obviate any delay where it is possible to do so.

A progress board, such as shown in Fig. 4, is maintained at the office of the general foreman, superintendent motive power and the general manager. This board contains racks in which are placed blocks or cubes having the numbers of the locomotives on them. A separate rack is provided for each class of repairs, boiler shop work, roundhouse work, etc. These racks are divided into days which show the number of days these locomotives have been in the shop; for instance, locomotive 606 is in the shop for class 1 repairs and has been in the shop 15 days. These cubes have different colored faces: the white face shows that the locomotive is going through the shop on schedule time, the red face shows that it is being delayed for lack of material, the yellow face shows that it is being delayed in the machine shop; blue, boiler shop; black, blacksmith shop; green, erecting shop; green and yellow, rod shop; green and white, pipe shop; green and black, wheel shop. The combination colors are applied by sticking yellow, white or black papers on the green side of the blocks. Thus the mechanical department officers can tell at a glance the condition of the shop and just why any locomotive is being delayed. The racks at the bottom of the board show the numbers of the locomotives that have gone through the shop by months, for the previous six months.

The results obtained from the installation of this scheduling system have fully justified its existence. The shop men are enthusiastic over it and it relieves the general foreman and the shop superintendent of a great deal of trouble. It gives them a much clearer idea of the performance and the workings of the shop than they ever had before. It gives them an opportunity to put their time on the larger questions of shop management and relieves them of a tremendous amount of detail work. Such a system, to be a success, must be directed by an able and wide-awake supervisor. He must be a man of a systematic nature, somewhat of a diplomat and one who is able to handle detail work. The success of the system at Du Bois is due to the fact that they have such a man in charge of the despatching, and to the full co-operation of everybody in the shop.

THE WAR SAVINGS STAMP CAMPAIGN.—A circular issued by the War Savings Stamp Trade News Committee states that for their respective first three months the American War Savings Stamp campaign is running ahead of the English campaign, a direct comparison showing that during this period England disposed of \$11,293,000 of these securities and the United States \$75,944,417—about \$2,000,000 a day. The money already put at the service of the government by the buyers of War Savings securities has transferred from millions of citizens to the national treasury, command of the labor and materials to build a fleet of about one hundred 5,000-ton ships.

LABOR SAVING DEVICES ON THE SOUTHERN

BY J. O. JOHNSON
Foreman of Freight Car Repairs

The two devices briefly described in the following article were made for use in repairing cars on the Southern, and the slight cost of manufacturing them has been repaid many times by the saving in labor effected.

YOKE FOR REMOVING ELLIPTIC TRUCK SPRINGS

The yoke illustrated in Fig. 1 is made of 1-in. by 4-in. iron, with the ends bent in forging so they will hook in the pedestal

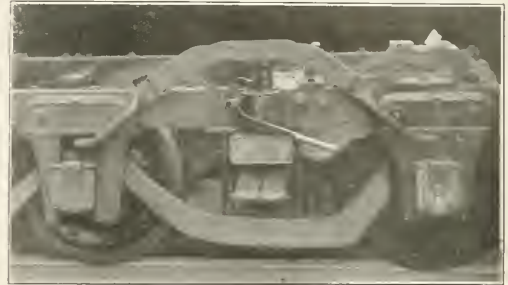

Fig. 1—Yoke for Use in Removing Elliptic Truck Springs

jaws. It is usually necessary to remove the side bearing, and the yoke when in place will extend above the truck bolster. A journal jack is placed between the yoke and the bolster and the elliptic springs compressed until a band of suitable size may be slipped on and hold the springs in compression. The jack may then be released and the springs easily removed. The band is made of $\frac{3}{8}$ -in. by 4-in. stock, and its size depends on the class of spring to be removed.



Fig. 2—Arrangement of Jacks for Use in Changing Truck Wheels

Elliptic springs may be removed by the use of this yoke without taking the truck from under the car.

JACKS FOR APPLYING PASSENGER CAR WHEELS

In removing the wheels from passenger car trucks, the old method of jacking and blocking up was not only slow but dangerous, and the arrangement shown in Fig. 2 was devised to remedy this condition.

Two 15-ton pump jacks were mounted on extension bases, as shown in Fig. 2, and the racks removed and replaced by longer ones, which would give a total lift of 48 in. The upper part of the racks in each case was provided with a jaw to hold one end of the reinforced cross beam. The chains shown are for the purpose of chaining up the trucks. Small

truck wheels attached to the lower end of the extension frames make it easier to move the jacks from place to place.

In operation, the truck ready to lift is run under the cross beam and chained to it. The truck is then jacked up and 48 in. will be found sufficient so that the wheels may be removed without interfering with either the brake beams or the hangers.

TWO VALUABLE HOSE DEVICES

BY E. S. NORTON

The New York, Chicago & St. Louis practice in renewing and clamping air hose is of special interest because two machines which were developed for the work have proved great time savers.

In pressing the coupling and nipple into the hose, a machine shown in Fig. 1 is used. It consists of a movable carriage *C*, mounted on a runway *DD*, consisting of two pieces of 5/8-in. by 1 1/2-in. iron, suitably bent and bolted to the bench. The carriage has a hinged cover or clamp which is securely held down by the taper wedge, as shown. At the left-hand end of the runway there is a block *E*, which is recessed to receive and hold the hose coupling. At the right end there is an 8-in. by 12-in. brake cylinder with a piston rod so arranged that the hose nipple will just slip on over the end and come up against the shoulder *F*.

The supply of air to and from the cylinder is controlled by the cutout cock, which has a release port drilled in the side. With the handle in one position this port is closed and air is admitted to the cylinder; with the handle in the other position, the air is shut off and that already in the cylinder is allowed to escape through the release port.

In operation the hose is placed in the carriage with an equal length projecting on either side, and is firmly held in place by the hinged clamp and tapered wedge. The air pressure is then applied, and as the piston is forced to the left, the nipple is pressed into the hose. A further travel of the piston moves the carriage to the left and forces the other end of the hose over the coupling. As a 4-in. travel of the

of the levers are forged to form the jaws of the machine, and the fulcrums are reinforced by extra clamps to give greater rigidity. The supply of air to and from the brake cylinder is controlled by a cutout cock, as explained in Fig. 1.

It is obvious that with the arrangement and relative proportion of the arms and levers shown, an upward movement of the piston will result in the jaws of the machine coming together with considerable force.

In operation the hose and clamp are placed between the jaws, with the jaw points striking the offsets on the hose clamp. Air pressure is then applied, which results in press-

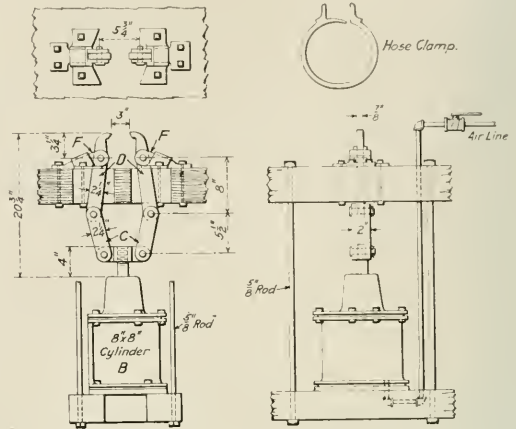

Fig. 2—Arrangement for Use in Clamping Air Hose to Coupling

ing the hose clamp together and holding it firmly around the hose while the bolt is being tightened. After the hose has been removed from the machine and the end of the bolt cut off, it is ready for service.

Both of the machines just described have proved valuable because of the reduction in the time required to fit up hose.

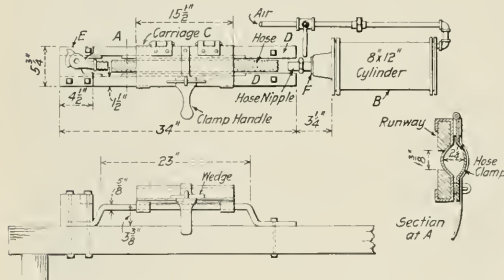

Fig. 1—Device Used in Pressing in Air Hose Nipples and Couplings

piston is sufficient for this work, a suitable block has been placed inside the cylinder to shorten the stroke. After the nipple and coupling have been pressed into an air hose, it goes to the next machine, which is conveniently located at the same bench and shown in Fig. 2.

This machine is used to press the hose clamps together and hold them while the bolts are being tightened. It consists of an 8-in. by 8-in. air cylinder *B*, mounted on two 4-in. by 6-in. sills, which are placed on the floor under the bench and securely bolted to it by the 5/8-in. rods shown. A metal crosspiece is screwed on the end of the piston rod and drilled and slotted at either side to receive the connecting arms *C* and suitable pins. The arms *C* are in turn connected to the levers *B*, which project up through two slots in the bench and are pivoted at the fulcrums *FF*. The upper ends



"ACH, THEY'VE GOT OUR RANGE AGAIN"

HOW JACK WINGATE SECURED A RAISE

What Is the Matter with the Supervision in the Mechanical Department? Read the Answer Here

BY HARVEY DE WITT WOLCOMB

PHEW! It was the beginning of another hot day in August. As Jack Wingate, the general roundhouse foreman at Collins, wiped his face with a piece of waste, he wondered how much longer he could stand the terrific strain under which he was working.

Business was heavier than usual and in addition, the weather was hot, in fact had been so hot for the past two weeks, that over half his regular force was laying off, overcome with the heat, and on top of these extraordinary conditions he had so many new men to break in that he was nearly crazy trying to keep the big organization moving without a tie up. Such items as settling a strike about every morning or talking some gang into staying that had been on the point of walking out, had become a matter of routine with Jack.

It was known from one end of the road to the other that the gang that Jack Wingate couldn't handle did not exist. He was a man among men—a man who, while he worked for the interests of the railroad, appreciated the fact that his men had rights as well as the company. Therefore, while he was called a hard man, he was a fair and just one.

As he sat in his poorly lighted cubbyhole of an office, which looked like a big dry goods box tacked up against the side of the pretentious brick building used by the engineers and firemen as a rest room, he nervously noted the increasing pile of work reports which had not been attended to before the engines left the terminal. For these he knew that he was personally held responsible. He could imagine how the "Old Man" would "blow up" when the reports were put in on his desk, for the "Old Man" did not follow any of the details but "put it up to his supervision" to get results.

It surely was a mighty easy matter to make an inspection and find little jobs here and there which demanded attention before they developed into bigger jobs, but the hard part was to get time and men enough to cover all these little jobs.

The sun beating directly down on the low sloping roof of his office made the place so unbearable that Jack had to give up his half-hearted attempt to attend to his mail, and he started for the engine despatcher's office to "line up." As he passed the fire hydrant back of his office, his attention was unconsciously attracted to some bait fish that were being kept alive in an old trough by allowing a small stream of water to run on them and it seemed to him that even a fish led a more desirable life than a roundhouse foreman.

These bait fish had a history. At one time there had been a joke about them, but of late it had ceased to be a joke and no one mentioned bait fish.

Early in the spring, Jack had talked about going trout fishing for two or three days, for he felt that nothing would equal a few days' fishing to restore his energy and fighting spirit. Accordingly he had made great preparations; but one thing after another had come up until it was too late for trout, so he changed his plans to a day's outing at the lake.

One day early in July, the engineer on the work train had a good chance to get some nice minnows and had brought about one hundred of them to Jack, for he knew of his long planned fishing trip. Together they had fixed up a temporary place under this hydrant where running water could be kept on the bait; but just as in the case of his trout-fishing trip, Jack had been unable to get off. He had even had to work every Sunday since early spring. He still had his minnows but they stood a very good chance of becoming full grown fish before he could use them.

Continuing towards the engine despatcher's office he noticed some of his old men cleaning up the premises. Jack had the satisfaction to note that every man was working with a real interest in what he was doing. About two months before he had put in a request for a raise for these faithful old employees but the "Old Man" had "gone right up in the air" and would not for a minute consider a raise for these "old pensioners" as he called them. Jack had tried to show him that, while the men were getting well along in years, they had been in the service for many years and had learned the ways of handling things so well that even with their feeble efforts they actually produced more work and made a better showing for their labors than some of the green, fly-by-night men whom they were lately putting on. He had even showed where other companies were glad to get these faithful old men, giving them much more than the railroad was paying them, but the big boss would not for one minute consider a raise of any kind and the old fellows were gradually drifting away, making it all the harder to fill their places with trustworthy men—in fact, in many cases making it actually necessary to use two higher rated men to handle some job that was formerly handled by one of these faithful old timers. The "Old Man," however, would not give in and told Jack he didn't care if he used four men on one man's job, he would not retract from the stand he had taken. However, things had suddenly changed, for just the other day the "Old Man" had told Jack to make out forms for increases for the old men, and, to Jack's amazement, had actually used the very argument that he would not listen to some time ago when Jack wanted to hold the old timers by granting slight increases. The "Old Man" gave quite a lengthy talk on the reward for meritorious service, intimating to some extent that Jack had not been on his job or else they wouldn't have lost so many of the old timers and Jack had had an answer ready to prove that he had brought the subject up in plenty of time, in fact, at a time when a smaller increase would have kept the men, but on second thought he did not make any reply for the "Old Man" was the big boss and one couldn't hold him responsible for any mistakes. Jack had been a railroad man too long not to realize that it did no good to fight the boss and the only way to get even was to "pass the buck" along down the line.

As Jack entered the roundhouse, he felt so disgusted with his lot that he would have quit on very slight provocation. Here he was working his head off as you might say, neglecting his home and family, putting in long hours every day in the week, with no time for rest or recreation. While the law demanded that every working man should have at least one day of rest in every seven days, it did not consider that a foreman, who, although he did no manual labor, was the hardest working man about the plant, and should be entitled to the same privilege—and as yet the company had not even offered to raise his pay.

Jack's one fault was that he was a little too timid about his own personal interests, but when cornered could always put up a stiff fight for his men. He was one of those fellows who never put themselves forward but tend strictly to their own jobs. When any of the general officers visited the place, they always had to send for Jack, and as he was always on the job, they had learned to respect his ability and loyalty, but as Jack was not a "four-flusher," they soon forgot the quiet, well-mannered, easy spoken man. Jack was not one

of those big "I" fellows and though he had been fighting for raises for his men for some time, he had said not one word about his own salary, feeling that his work ought to recommend itself.

As he entered the engine despatcher's office he overheard some engineers and firemen discussing their wages, and feeling a little out of sorts, he answered their greetings by telling them that it was about time they were satisfied with what they received and gave the poor shop man, who actually did the hard work, a show. "Well," retorted one of the engineers, "we are not like you, afraid to ask for our rights." Just at this moment something came up to distract Jack's attention, but the engineer's words kept running through Jack's mind all day. He couldn't get over the taunt and decided to hit the "Old Man" for an increase at the first opportunity. Although he had several good openings, he did not have the courage to come out flat-footed and demand a raise, but compromised by dropping a personal note asking that something be done towards granting him an increase. He felt guilty when he met the "Old Man" the next morning, but as nothing was said about increases, he soon forgot the incident and it ran along for a matter of over a month before he even remembered asking for a raise, and then the matter was again brought up to him very forcibly by receiving a nice offer for a better position with an industrial concern. After thinking the new offer over carefully, he decided to go to the "Old Man" for advice.

While he thought he had been a successful foreman for the past 15 years, working for the same company so that he knew their work and requirements probably better than the officers, he could hardly convince himself that some other company was willing to pay him \$50.00 a month more to start in with them. He could not appreciate the fact that his ability in handling men and getting out the work was worth big money to any company during these difficult times, and that this in addition to his long training in locomotive repairs made him a very important and valuable addition to their supervising forces.

While Jack felt very backward about bringing up such a delicate matter to the "Old Man," he nevertheless realized it was the chance of a lifetime, so decided to seek advice from the "Old Man." When the "Old Man" heard about the offer, he slapped Jack on the back and told him to forget it for the company had his case under advisement and would certainly do something for him.

Actually feeling ashamed at having brought up the subject, he returned to his duties with renewed energy, expecting soon to receive a notice of his increase. However, the matter drifted along for two weeks more when one day the "Old Man" sent for Jack to come up to the office. After delivering a long talk on his past good record, telling him how much they appreciated his loyalty and ability, the "Old Man" closed his remarks by saying, "and I am now pleased to advise you that beginning with the first of next month you will receive a \$5.00 increase in your monthly salary."

As Jack heard this, he suddenly felt old and lonely, and was beset by a depressing sense of failure. He, whose ability and personal efforts secured for the company an effective return approaching 100 cents on every dollar spent in wages at a busy engine terminal, had expected more than this.

Mechanically his thoughts drifted over the past, bringing to his mind many of the increases he had secured for his men, in some cases as high as 20 and 25 per cent, and now he was being offered an increase of less than four per cent. What had he done or what had he not done to warrant such treatment as this? His thoughts were suddenly interrupted by the "Old Man" remarking that he was to be congratulated on his raise.

Mechanically Jack thanked him and returned to the roundhouse, to the noise and hustle—to the smoke and gas which had become like home to him. There he could review the entire situation undisturbed.

As he thought over the question, Jack could not see but that he was entitled to at least as great an increase as some of his common workmen, for if he was not worthy, why had the company kept him on as general foreman? Wasn't his position of more importance than that of a workman? He certainly had to assume far greater responsibility. If he wasn't deserving in his present position, could he make good with the other concern if he should accept their offer? Who would take his job if he should leave? Could any of his foremen do any better than he had done?

These and many other questions ran through his mind until he gave up trying to decide until he slept over the proposition.

At the supper table that night his wife was commenting on the many increases in living expenses, quoting many staple articles of food which had doubled in price in a few months, and Jack remembered bitterly that his own value had increased less than four per cent after his years of service.

Then and there, Jack made the decision that gave him a just raise; he wrote the other concern that he would accept their offer and report for duty the first of the next month.

DEVICE FOR REMOVING GASKETS FROM SIGHT FEED LUBRICATORS

BY E. A. M.

When it becomes necessary to change a glass in sight feed lubricator, it is often difficult to remove the rubber gasket or washer, and the tool illustrated will be found convenient for this work. In fact, it is one of the many small tools that help in shortening a locomotive's time at terminal points, because they permit the work to be done much quicker than by the old hand methods.

As indicated, the cutting tool consists of a round piece of steel, counterbored and drilled with one end expanded and cut to form four teeth. These teeth are given proper clear-

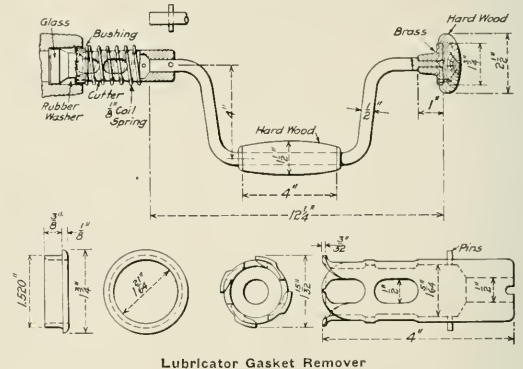

ance both ways and the cutter is hardened. A hardened steel bushing is provided which is just large enough to go into the lubricator, where the glass and rubber washer are held by a jamb nut.

The cutter is fastened to a homemade bit stock by a pin, as indicated, but before the tool is assembled, the bushing and a suitable coil spring are slipped on over the cutter, as shown. This is made necessary because on account of the clearance of the cutter teeth, their outside diameter is less than the inside diameter of the bushing.

In operation the jamb nut holding the broken lubricator glass is removed and the assembled tool is put in place with the bushing just fitting into the lubricator. The bit stock is then turned by hand and the gasket reamed out, the thread for the jamb nut being protected by the bushing. The object of the spring is to hold the bushing in place.

RECLAIMING HIGH SPEED STEEL

A Recently Devised Process Converts Scrap High Speed Steel into New Stock of the First Quality

WITHIN the past two years what practically amounts to a new industry has sprung up in Syracuse, N. Y., with the formation and development of the Onondaga Steel Company, Inc. This company's successful efforts in the reclamation of scrap high speed steel are noteworthy, and it is estimated that a total of nearly 500,000 lb. of this metal have been reclaimed since July, 1916, when the busi-

ness was incorporated. It is hard to estimate the value of this saving, because high speed steel is one of the most important factors in all mechanical production, particularly with railroads, arsenals and navy yards.

scrap of carbon steel tools, when as a matter of fact they were worth more, pound for pound, than any of the non-ferrous metals except silver and gold. Probably from 20 to 40 per cent of the high speed steel manufactured in this country is thus lost to the trade.

The reason for the relatively low price of scrap high speed steel is its varying and uncertain quality and the difficulty in separating different kinds; each manufacturer has been unwilling to accept any except his own brand. Realizing this condition, the founders of the Onondaga Steel Company set about to discover a way of separating high speed steel from carbon steel and they succeeded so well that it is now possible to distinguish not only different grades of high speed steel, but different brands of the same grade. When this method was developed the problem was to find what materials must be added to give the required chemical composition; also, it was necessary to develop special furnaces and, in fact, the entire method of steel treatment was worked out until finally a high speed steel was produced that satisfied the most exacting requirements and compared favorably with the best steel on the market.

Starting with a one-pot furnace in the small building illustrated in Fig. 1, the company has grown until its present capacity is 17 tons per month and the equipment includes five two-pot gas furnaces, two annealing furnaces and three small steam hammers.

A list of the company's customers shows that they are well scattered over the United States and Canada, and include 700 of the leading railroads, supply houses, motor companies and, in fact, every branch of the metal trades.

On account of the rapid growth of the business it has been



Fig. 1—Original Quarters of the Onondaga Steel Co., Inc., at Syracuse, N. Y.

Railway shop men have long understood the necessity of saving the scrap turnings and chips of copper, brass, babbitt,



Fig. 2—The New Plant with an Estimated Capacity of 60 Tons Per Month

etc., but, hitherto, no special attention has been given to the saving of high speed steel scrap, because its scrap value has been in no way proportional to the first cost. In some cases it has been used to tip certain tools by brazing or welding, and a few shanks have been drawn out to make tool bits, but in the main, broken and worn high speed steel reamers, drills, milling cutter, etc., have been allowed to go in with the

necessary to provide more floor space and Fig. 2 shows a new set of buildings recently completed at Messina Springs, a suburb of Syracuse. The new plant is now almost ready for operation and the equipment will include five large furnaces, suitable annealing furnaces, a rolling mill, one 2,000-lb. and one 3,000-lb. steam hammer. It is estimated that the capacity of the new plant will be about 60 tons per month,

devoted exclusively to the reclaiming of high speed steel scrap.

Steel for reclamation is generally received in lots from twenty-five to a few hundred pounds. The steel is all brought up to one uniformly high standard and is not subject to the customer's specification, except in regard to size. It was originally planned to maintain a supply of standard stock sizes on hand, so that when a shipment of scrap high speed steel was received, an equal weight of finished bars might be immediately forwarded to the customer, but it has not been possible to follow this policy on account of the great demand for this service.

The Onondaga Company wishes it understood that their process applies only to the reclamation of scrap high speed steel, and it is not desirable to melt down bars of obsolete size, providing the quality is good, for they can be drawn out to needed sizes, welded or made suitable for use in some other way.

Briefly stated, the reclamation process is as follows: A decidedly miscellaneous assortment of scrap high speed steel arrives at the plant for reclamation. It consists of broken drills, worn out reamers, broken taps, obsolete milling cutters, the shanks of lathe tools, end trimmings from the forge shop, etc. As suggested earlier in the article, the success of the entire proposition hinges on the possibility of correctly sorting this scrap, and experts have been developed who test each piece separately on an emery wheel and are able to tell by comparing the sparks with those of known samples, not only what kind of high speed steel it is, but the grade as well. Chips and turnings cannot be used unless they are absolutely free from foreign material.

After sorting, the different grades are so proportioned that a constant mixture results and the required new elements are added to give a uniform composition. The steel when melted is poured in the form of ingots about 4 in. square by 2 ft. long, which are carefully treated. They are then sent to the surface grinder. It is necessary to grind out all surface checks, slag holes, etc., otherwise these imperfections when hammered into the finished bars develop into seams. After being ground, samples are taken for chemical analysis.

The ingots are drawn out or cogged under a heavy steam hammer to bars 2 in. square by about 6 ft. long and again they go to the grinder for removing sharp edges and surface imperfections, and then forged as often as necessary to bring them down to the required size for finishing. After each cogging or roughing operation the bars are very carefully in-

spected for fracture. When surface imperfections are found the same are carefully ground out.

Proper inspection forms a vital part of the process and the greatest care is exercised from sorting the scrap to shipping the finished product, in order that only the best grade of



Fig. 3—Brinell Instrument Used in Testing the Hardness of Reclaimed Bars

high speed steel shall be produced. In addition to the chemical test and constant inspection during the process of manufacture, each heat is tested for hardness by Brinell's method. Here again the results show but little variation,

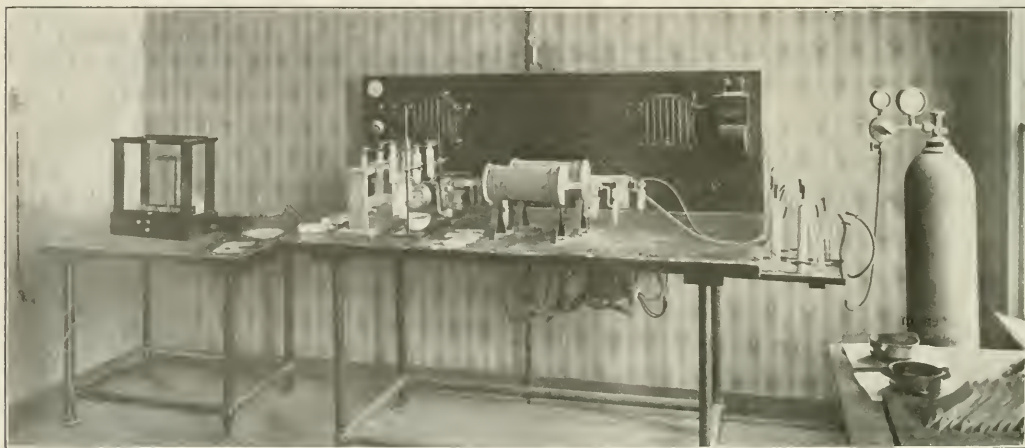

Fig. 4—Laboratory in Which Tests Are Made of Onondaga Steel

which indicates that the product is uniform. Figs. 3 and 4 show the Brinell instrument and the testing laboratory.

In conclusion it may be stated that the Onondaga Steel Company has taken a step in the right direction, and by thus converting high speed steel scrap into a useful material it has done much to conserve this class of steel.

MISCELLANEOUS EQUIPMENT AT THE SHOREHAM SHOPS

BY F. W. SEELERT

A handy drill jig for holding locomotive handrail columns has been developed at the Shoreham Shops of the Soo Line and is shown in Fig. 1. It is adjustable for any height of column and is arranged to drill and tap the hole in the base as well as to drill the large hole in the head for the railing pipe. As indicated in the illustration, the movable bracket is adjusted to suit the handrail column and a spanner wrench is used to tighten the hollow, threaded holding nut.

Fig. 2 shows a fixture for holding eccentric straps while drilling the holes for the babbitt inserts as used by many railroads. This fixture is constructed of boiler plate and angle iron and is made to hold any size of strap on the



Fig. 1—Drill Jig for Holding Handrail Columns

system. The boiler plate proper to which the strap is clamped is arranged to swing about a center which coincides with the center of the strap and the whole may be clamped in any position by means of a nut on the back side.

A pneumatic riveting and shearing machine for coupler yokes is shown in Fig. 3 and attention is called to the heavy construction which is necessary for this kind of work. The machine is composed of the 28-in. by 18-in. stroke cylinder *J* with lugs *B* cast on both sides. To the lugs are fastened the 16-in. I-beams, which in turn are reinforced and supported by the plates *C*, 1 in. by 15 in. by 8 ft. long. These are bent around the cylinder. Underneath the cylinder *J* a 10-in. diameter cylinder that is filled with kerosine is mounted. This cylinder is provided with a by-pass valve

and acts as a cushion for the air cylinder, as without this cushioning effect the machine would soon jar itself to pieces. The holes in the levers at *D* and *D* are slightly oblong to allow for the radial movement of the levers. The ratio *D* *E* to *E* *D* is three to one, making a pressure of about 73

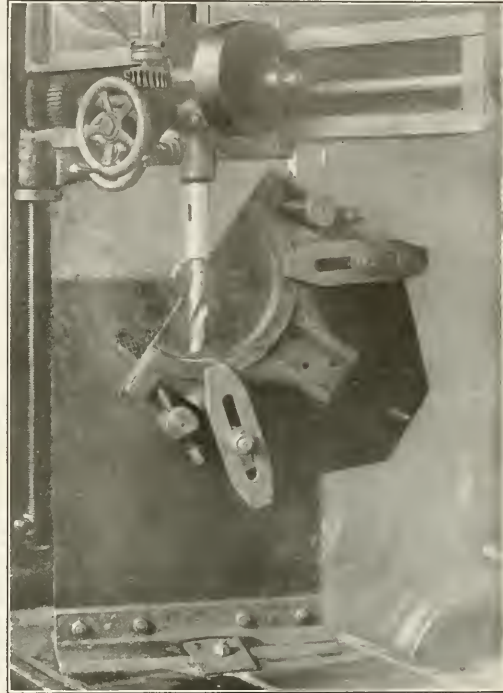

Fig. 2—Fixture for Holding Eccentric Straps

tons on the ram *R* at an air pressure of 80 lb. in the cylinder *A*. The machine is operated by the three-way cock *H*. The cutout cock *I* operates the brake cylinder *K* by means of which the couplers are pushed against a stop and held in

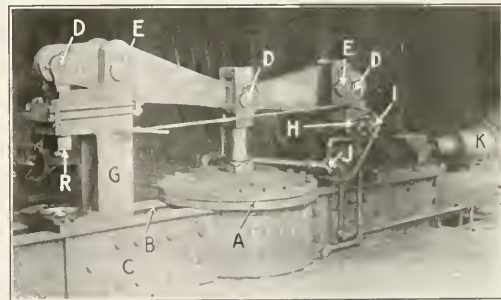

Fig. 3—Pneumatic Riveting and Shearing Machine for Coupler Yokes

place while the rivets are being sheared. The air cylinder *A* is single acting, but in cold weather the piston is a little sticky. To counteract this the air pipe leading into the top head with the three way cock *J* was applied, to force it

down. The levers and the upright *G* are forged from a good grade of hammered iron.

All shearing is done on the right hand side of the machine and riveting on the left by means of the hardened ram *R* and the opposite plate which are both cupped to give the required shape to the rivet heads.

The home-made stenciling machine shown in Fig. 4 is used for marking or stenciling the sizes and numbers on reamer shanks, tap shanks and similar tools. The spindle to which the long operating lever is attached is hollow and

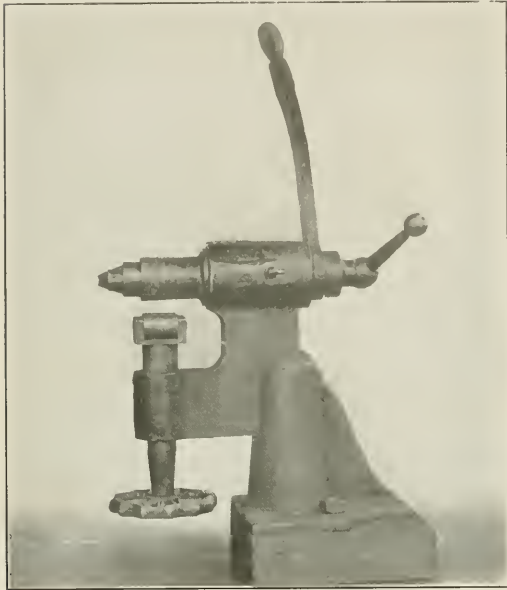

Fig. 4—A Convenient Stenciling Machine

the rod inside of it is threaded on one end to receive the ball crank, as shown. The other end of this rod has an interesting arrangement for quick release of the stencil collars.

There are several different collars clamped on the front end of the spindle. As on a tap for instance, the size, number of threads, shape of thread, V or U. S. S., and the owner's monogram are all stenciled on at one operation. The tap or reamer to be marked is laid on the two rollers on the adjustable support right under the spindle, the sup-

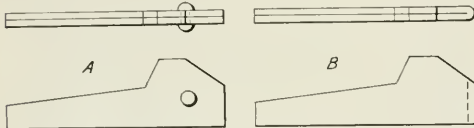

Fig. 5—A Riveted and a Home Made Cotter Key

port being raised by turning the small handwheel on its lower end until the shank of the tap or reamer bears tightly against the two plain contact washers or rollers. These contact washers control the depth to which the figures are stenciled. The spindle is then given a part of a revolution, just enough to roll the figures over the shank of the work. The collars that are used in this machine are also a home product and are arranged so that any combination of fractions and thread numbers can be obtained. For sizes over

1 in. we have collars that stamp the whole number at once—like $1\frac{1}{4}$ in. or $1\frac{1}{2}$ in. and some other much used sizes. The little knob shown in front of the main bearing can be slipped into a circular slot in the spindle so as to limit the stroke of the operating lever.

Fig. 5 shows the method of making small cotter keys for use on ashpan and similar work. At Shoreham most of these keys are made from old standard flues which are rattled, heated and flattened out and then the keys are punched out as shown at *B*, Fig. 5. As this key requires no riveting it can be produced at a considerably lower cost than the key shown at *A*, Fig. 5.

THROTTLE SAFETY APPLIANCE

The Missouri, Kansas & Texas has recently issued instructions to equip all locomotive throttle quadrants with a pin and Safety-First tag as shown in the illustration. The pin is placed in a hole drilled in the quadrant just behind the throttle lever when it is closed, and a suitably metal tag is attached to a hole in the bottom of the pin by means of a wire hook. On one side of the tag are stamped the words "Safety First—M., K & T. Lines;" and on the other side the phrase, "Do Not Open Throttle."

In practice no man is allowed to do any work beneath an engine which is under steam until he has first put one of these pins in the quadrant and attached the tag. In this

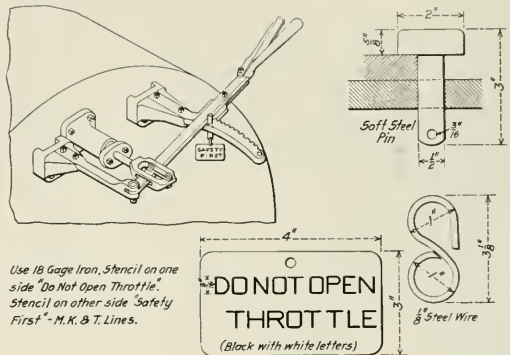

Safety Pin for Locking Throttle Levers

Use 16 Gage Iron, Stencil on one side "Do Not Open Throttle". Stencil on other side "Safety First"—M. K. & T. Lines.

way he is amply safeguarded, for the engineer or hostler will not remove the tag and pin and start the engine without first looking to see if someone is underneath. Some roads are already equipped with such pins to prevent opening of the throttle, either accidentally or by some unauthorized person. These are applied whenever a locomotive is at rest in the engine house territory irrespective of whether work is being done on the engine or not.

ELECTRIC LOCOMOTIVES FOR MANCHURIAN COAL MINE.—

The 50-ton electric locomotives for use by the Fushun collieries for freight handling are the first of the kind ever built at the South Manchuria Railway workshops. They are for the standard gage. Each locomotive is designed to haul 580-ton trains at the speed of 12.9 miles per hour on the level tangent track, exclusive of the weight of the locomotive, the trolley voltage being 1,200 volts. They are of the two-bogie type, each bogie carrying 125-horsepower motors. The total weight is 97,200 lb.; ballast weight, 15,200 lb.; weight on drivers, 112,400 lb.; weight per driving axle, 28,100 lb.; and weight of a motor, 5,000 lb.—*Commerce Reports.*



NEW DEVICES

A NEW AXLE LATHE

The No. 3 axle lathe illustrated in Fig. 1 is a high production machine recently placed on the market by the Niles-Bement-Pond Company, 111 Broadway, New York. It is designed for machining axle forgings, as well as rough turned axles, and being center driven is adapted for turning wheel seats and journals at both ends of car axles simultaneously.

The bed is of rigid construction reinforced by cross-girts of box section 8 in. wide. The tracks for the carriage consist of a wide flat way at the back of the bed and a track of an improved compensating "V" shape at the front. This "V" track has an angle of 15 deg. at the back and an angle of 70 deg. at the front. The 15 deg. angle on the back of

herringbone gear provides a smooth, powerful drive, and all objectionable noise is eliminated when running at high velocity. The axle is driven by a steel equalizing driving plate, having lugs cast integral which engage both ends of the double driver dog. By means of this driving plate crooked or irregular axles can be machined without setting up bending strains. The lathe is provided with two carriages, which have power longitudinal feeds by a right and left hand screw positively driven by gearing. The split nuts engaging the leadscrew are provided with automatic opening devices which release them when the carriages come in contact with set collars on the tappet rod at the front of the machine.

The carriages are held down by clamps for their full length and are adjustable to the front and back vertical surfaces of the bed by taper gibs. Two clamps are provided at the front

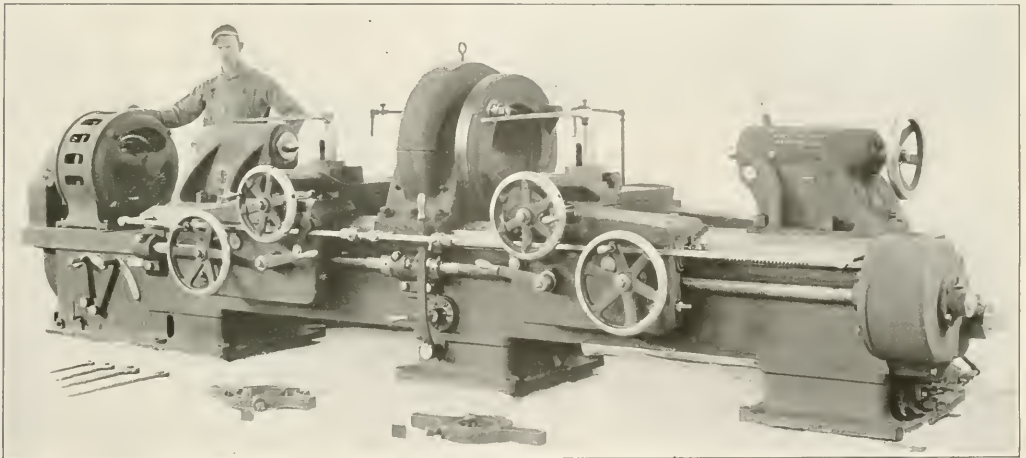

Fig. 1—A New Axle Lathe Designed for High Production

the "V" serves a double purpose, in that it presents a thrust surface at right angles to the combined forces of the tools, thus eliminating all tendency of the carriages to climb under heavy cuts, and it automatically compensates for wear of both the carriages and the bed.

The center driving head is of massive construction, completely enclosing the main driving gear and forming an oil reservoir in which the gear runs. It is clamped to the bed by six large bolts and is adjustable longitudinally along the bed. The main drive is by means of the large steel herringbone type gear and pinion, shown in Fig. 2. The gear and pinion are carried between bearings in the head, which are of large proportions and special provision is made for a liberal supply of oil. Because of the spiral action of the teeth, the

of the carriages. One of these is used for clamping the carriage to the bed when turning against shoulders and facing the ends of the axles. This clamp is operated by a bolt on the top of the carriage. The other clamp is under the bridge and further decreases the tendency of the carriage to lift during the burnishing operation.

Wipers are attached to both carriages, to remove all chips and dirt from the shears. They are fitted with felt pads and provide the surfaces with a continuous supply of clean lubricant. A complete lubricating system for the tools is provided by means of a pump, jet pipes, reservoir and collecting channels. The tool slides are provided with a trough which is connected with channels in the carriage bridge for carrying off the lubricant. The aprons are of double wall con-

struction, and all of the mechanism except the operating levers, is completely enclosed. All shafts are supported at both ends.

The feed gears are located at the right hand end of the bed and are completely enclosed. The feed change lever is placed at the center of the machine within easy reach of the operator. Three feeds are provided for the carriages 1/16 in., 3/32 in. and 3/16 in. The carriages have hand traverse on the bed and tool slides have hand cross feed.

The axle is carried on dead centers mounted in two heavy tailstocks which are adjustable longitudinally along the bed and can be clamped in position by four large anchor bolts. To prevent slipping, a pawl is provided which engages a rack cast in the bed. The tailstocks have taper gibs at the front and back of the bed, permitting the alinement of spindles.

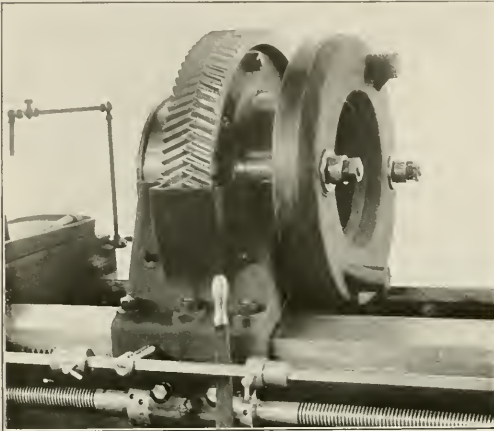

Fig. 2—The Herringbone Type Gear and Pinion Drive

The spindle of the right hand tailstock is adjustable by a handwheel.

Four different methods of driving this lathe are provided so the purchaser may select the one best suited to his requirements. They include the cone pulley, the single pulley mounted on a speed box, the alternating current motor and the direct current motor drives.

For handling axles in and out of the lathe a crane can be furnished at extra cost. This crane has a convenient gripping device and a chain hoist and axles can be easily handled by one man. The following are given as the general dimensions of the machine:

Swing over bed shears.....	30 1/2 in.
Swing over tool slide.....	13 in.
Diameter of hole in driving head.....	13 in.
Length of bed.....	9 ft. 3 in.
Maximum distance between centers.....	14 ft. 0 in.
Length of tailstock spindles.....	5 in.
Traverse of R. H. spindle.....	9 in.
Length of carriage bearing on bed.....	30 in.
Number of feeds.....	3
Feeds per revolution of driving head.....	1/4 in., 3/32 in., 3/16 in.
Revolutions per minute.....	16 to 48
Kinds of drive.....	4
Cone pulley:	
Number of steps.....	3
Maximum diameter of pulley.....	32 in.
Width of belt.....	7 in.
Speeds to driving head.....	6
Floor space.....	17 ft. 2 in. by 4 ft. 8 in.
Single Pulley:	
Diameter.....	26 in.
Width of belt.....	8 in.
Speeds to driving head.....	4
Floor space.....	17 ft. 2 in. by 4 ft. 8 in.
A. C. Constant Speed Motor:	
Driving motor, hp.....	25
Speeds to driving head.....	4
Floor space.....	18 ft. 9 in. by 4 ft. 3 in.
D. C. Adjustable Speed Motor:	
Driving motor, hp.....	25
Speeds to driving head.....	48
Floor space.....	19 ft. 1 in. by 4 ft. 0 in.

FEEDWATER TREATMENT

The present coal shortage and demand for increased boiler efficiency call attention once more to the ever present need of a satisfactory feed-water treatment. It is self-evident that scale not only lowers the equivalent evaporation of a boiler and the available boiler horsepower, but decreases the life of tubes and firebox sheets.

Among the non-chemical methods of treating feed-water, that devised by the Ferrochem Company, Ltd., 30 Church street, New York, is interesting and has given good results in actual practice. Perhaps the most notable example has been in the treatment of Los Angeles city water, where an analysis showed the following content:

	Grains per gallon
Total solids.....	28.0
Organic and volatile.....	3.2
Sodium chloride.....	2.8
Sodium sulphate.....	3.9
Calcium carbonate.....	5.9
Magnesium carbonate.....	4.6
Silica—Free carbonic acids.....	Trace
	9.3

This water is very bad, forming hard scale in a short time and it has been successfully treated by the Ferrochem process for a number of years.

As shown in the illustration the machine is simple in construction, consisting of three balls rotating in a circular raceway through which the water passes before going to the boiler. The balls are made of an alloy of pure metals, which is readily abraded when the balls are whirled in the raceway by the action of the water. Fine particles of Ferrochem metal then enter the boiler with the water and neutralize the scale forming salts, both those in solution as well as those in suspension. This prevents the salts from cementing

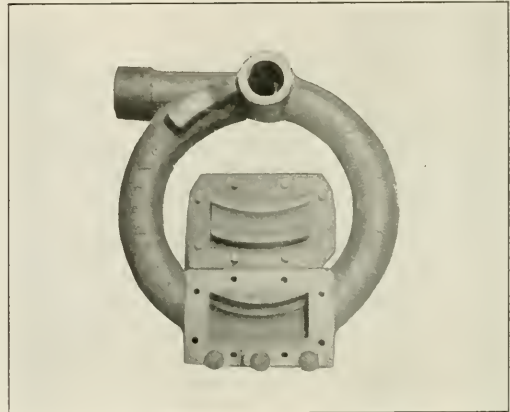

Apparatus for Ferrochem Water Treatment

themselves together in the form of hard scale on the exposed surfaces of the boiler. It is claimed that the introduction of Ferrochem metal into a boiler not only neutralizes all the salts in incoming water, but softens and loosens the scale already formed. The precipitation of the salts is in the form of a sludge or mud which does not harden and may be readily blown or washed out.

Among the advantages of a non-chemical method of feed-water treatment may be mentioned less danger of foaming, no decomposition of packing and gaskets, and exhaust steam that is not contaminated by various chemicals.

Also the non-chemical method just described has an additional advantage in being automatic in action and requiring practically no care.

The success attending the use of the Ferrochem method in

industrial plants raises the question as to its application to locomotive feed-water problems and there is no apparent reason why it should not work out well. There would be about two pounds back pressure due to the machine, so it probably could not be used between the tank and the locomotive injector, but it could be placed between the water supply and the tower or trough from which the water is taken, as the case may be.

BOILER BRACE COUPLING

An improvement in the method of fastening boiler braces has been recently patented by S. U. Walck, of Lansford, Pa., and the device is shown in detail in the illustration, which is a vertical section through the boiler where the brace is applied.

Referring to the illustration, *A* is the back head of the boiler and *B* the wrapper sheet. The brace *C* is held by rivets to the wrapper sheet and the back head is drilled and tapped with a standard boiler tap to take the shell *E*. As indicated, this shell is chamfered and has a concave seat machined to suit the convex face of the nut *K*. *K* has a square head and may be tightened by means of a suitable wrench. The shell *E* is threaded on the outer end to receive the cap *F* which is provided with a recess *H* to allow for tightening.

In applying the brace and coupling, the inner end of the brace is securely held to the wrapper sheet by riveting or otherwise and the threaded portion is passed through the shell. The nut is tightened on the brace, so that a few of the threads will project through and may be riveted over.

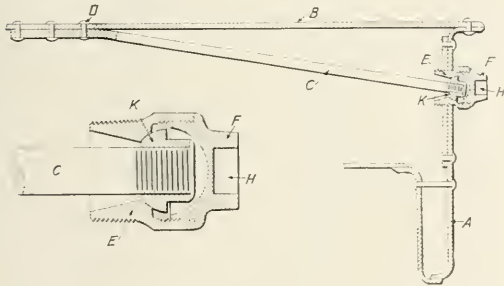

Boiler Brace Coupling

The cap is then screwed into the shell, enclosing the nut in the manner shown and making a steam-tight joint.

If it becomes necessary to inspect the braces, the cap may be removed by a wrench inserted in the recess in the end and should the brace and nut turn together, it will be evident that the brace is broken. In order to remove the part of the brace which is riveted to the boiler sheet the rivets holding firm may be cut, allowing the inner portion to fall down and be taken out. After the old brace is removed, a new one may be slipped into the boiler through the opening in the end of the boiler head and the inner end drawn up to the wrapper sheet. After tapping out the old holes, screw plugs may be screwed into the wrapper sheet and brace, allowing them to extend above the sheet for a distance of a few threads, which may be afterwards riveted over, the same as a staybolt, thus making a tight joint. The shell may then be screwed into the boiler head and the parts replaced, as already described.

This form of boiler brace possesses the advantages of being easily applied and readily inspected. In addition, it provides a flexible connection at one end and is much less likely to break than a rigidly riveted brace.

AIR VALVE LIFT GAGE FOR CROSS COMPOUND AND SINGLE STAGE STEAM DRIVEN AIR COMPRESSORS

The purpose of the air valve lift gage, which is made by the Westinghouse Air Brake Company, is to enable repairmen to determine the lift of air valves of steam-driven air compressors.

To determine the lift of the left hand air valve, the gage is first applied to the left flange of the air cylinder, as illustrated in Fig. 1, and the sliding arm adjusted until its end rests against the stop on the air valve, in which position it is locked by means of the thumb nut. With the arm thus locked,

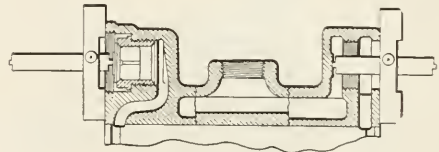

Fig. 1

the gage is applied to the valve cap, as shown in Fig. 2. If the gage arm fails to touch the stop on the valve when the shoulder on the sliding bar rests upon the face of the collar, the valve has a lift greater than standard by an amount equal to the distance between the gage arm and the stop. If this lift is greater than the maximum permissible, a repair valve having a long stop is substituted for the old valve and the

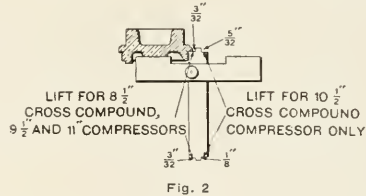

Fig. 2

stop lowered until the standard lift is reached, as indicated by the gage.

To determine the lift of the right hand air valve, the gage is first applied to the right flange of the air cylinder, as illustrated in Fig. 1, and the sliding arm adjusted until its end rests against the stop in the cylinder, in which position it is locked by means of the thumb nut. With the arm thus locked the gage is applied to the air valve cage and air valve, as

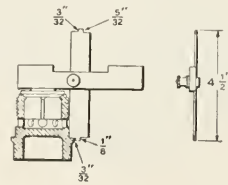

Fig. 3

illustrated in Fig. 3, and if the valve has proper lift, the shoulder on the sliding arm will just rest upon the upper side of the collar of the air valve cage, as illustrated. If the gage arm fails to touch the stop on the valve when the shoulder on the sliding bar rests on the collar face on the cage, the valve has a lift greater than standard by an amount equal to the distance between the stop and the gage arm.

PORTABLE ELECTRIC DRILL AND GRINDER

Portable electric tools which replace hand operation, save time and labor and increase the output of a given number of men. Particularly is this true of a portable electric drill such as that shown in Fig. 1. Less "elbow room" is required by a workman using this device, and since he can drill a great many more holes per hour, he can replace a number of men who may be given to other

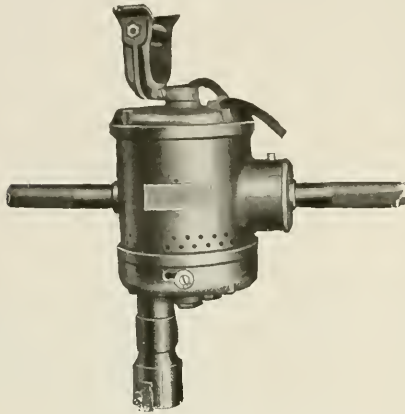

Fig. 1—Portable Electric Drill

tasks. This drill, which is manufactured by Gilfillan Brothers Smelting and Refining Company of Los Angeles, Cal., is equipped with gears to give two speeds. The speeds are changed by means of a knob on the bottom of the gear case. The gears themselves are made of chrome nickel steel and run in grease. Ball bearings are used throughout. A 1/2 in. Standard chuck and a sturdy electric switch are

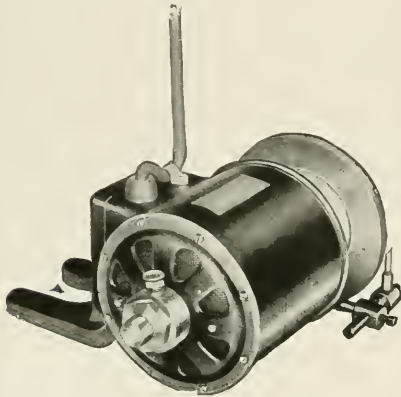

Fig. 2—Tool Post Grinder

provided. The speed range is 400 r.p.m. on low speed and 700 r.p.m. on high speed, Westinghouse motors being furnished.

The same company also manufactures a tool post grinder shown in Fig. 2 and adapted for use on lathes. An angle plate can be clamped around the tool post and a vertical adjustment of the grinder is provided. This grinder is

equipped with a Westinghouse 1/4 hp. motor running at 3400 r.p.m. It is also provided with a six in. by three-eighths in. grinding wheel, an extension mandrel for internal grinding fitted with a 1 1/2 in. by 3/8 in. wheel, a tooth rest for cutter grinding and an electric attachment plug with 7 1/2 ft. of cord.

BALANCING STAND

The balancing stand illustrated is manufactured by the Rockford Tool Company, Rockford, Ill., for the purpose of balancing pulleys, cones, armatures, flywheels, etc.

The end brackets or standards are adjustable in or out to suit the length of the part to be tested, and in the larger sizes this adjustment is made by means of a rack and pinion. On each standard there are two rotating disks which have been hardened and ground and are supported on ball bearings. The special arrangement of ball bearings used makes these disks turn with great ease and for that reason the stand is exceedingly sensitive. The two disks on each standard are separated so that a round bar of iron may be supported by them at four points and be free to turn easily.

In operation, the stand is placed on a reasonably level floor and no further leveling or adjustment is necessary. The

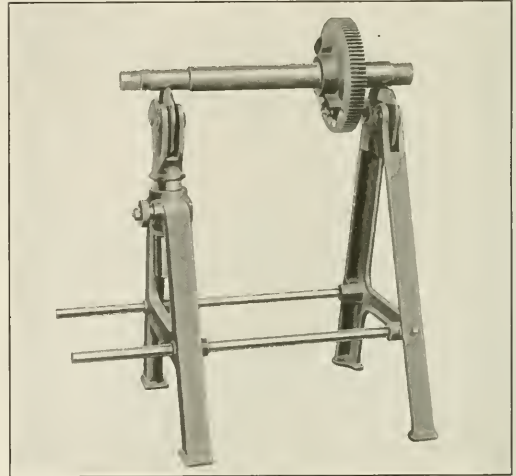

Stand Used in Balancing Pulleys, Fly-wheels, Etc.

shaft and pulley or flywheel, as the case may be, is then allowed to rest on the disks, and any lack of balance will be evident and may be corrected in the usual way.

The advantages of this tool are its great sensitiveness and the fact that it does not have to be leveled like the old-fashioned parallels. The stand is made in the following five sizes:

	Swing	Greatest distance between standards	Capacity
No. 1 bench size.....	22 in.	20 in.	800 lb.
No. 2 floor size.....	46 in.	30 in.	800 lb.
No. 2-A floor size†.....	46 in.	30 in.	2,000 lb.
No. 3 heavy size*.....	6 ft.	6 ft.	5,000 lb.
No. 4 heavy size*.....	8 ft.	8 ft.	10,000 lb.

†No. 2-A has extra heavy bearings and large disks.
*Nos. 3 and 4 are fitted with a rack and pinion for adjusting distance between standards.

SHORTEN THE WAR.—The sooner the irresistible might of this great republic is organized and put into full action the sooner the war will end. Every dollar invested in government securities works to shorten the war, to save the lives of American soldiers and sailors. Buy Liberty Bonds.

Railway Mechanical Engineer

(Formerly the RAILWAY AGE GAZETTE, MECHANICAL EDITION
with which the AMERICAN ENGINEER was incorporated)

PUBLISHED ON THE FIRST THURSDAY OF EVERY MONTH BY THE
SIMMONS-BOARDMAN PUBLISHING COMPANY

EDWARD A. SIMMONS, *President* L. E. SHERMAN, *Vice-President*
HENRY LEE, *Vice-President and Treasurer* M. H. WIUM, *Secretary*
WOOLWORTH BUILDING, NEW YORK, N. Y.
F. H. THOMPSON, *Business Manager, CHICAGO.*

Chicago: Transportation Bldg. Cleveland: Citizens' Bldg.
Washington: Home Life Bldg.
London: Queen Anne's Chambers, Westminster.

ROY V. WRIGHT, *Editor*
R. E. TRAYNER, *Managing Editor*
C. E. PECK, *Associate Editor* E. L. WOODWARD, *Associate Editor*
A. F. STREIBING, *Associate Editor* C. W. FOSS, *Associate Editor*

Entered at the Post Office at New York, N. Y., as mail matter of the second class.

Subscriptions, including the eight daily editions of the *Railway Age* published in June in connection with the annual convention of the Master Car Builders' and American Railway Master Mechanics' Association, payable in advance and postage free: United States, Canada and Mexico, \$2.00 a year; Foreign Countries (excepting daily editions), \$3.00 a year; Single Copy, 20 cents.

WE GUARANTEE that of this issue 7,700 copies were printed; that of these 7,700 copies 6,557 were mailed to regular paid subscribers, 137 were provided for counter and news companies' sales, 341 were mailed to advertisers, 166 were mailed to exchanges and correspondents, and 499 were provided for new subscriptions, samples, copies lost in the mail and office use; that the total copies printed this year to date were 32,600, an average of 8,150 copies a month.

THE RAILWAY MECHANICAL ENGINEER is a member of the Associated Business Papers (A. B. P.) and of the Audit Bureau of Circulations (A. B. C.).

Word received from Captain William R. Pearson, of Company C, 35th Engineers (Railways), indicates that that regiment is now in service in France. The 35th Engineers was stationed at Camp Grant, Rockford, Ill., previous to its departure for Europe.

In a fire in the Southern Pacific terminal at Lordsburg, N. M., on the 14th of March, a roundhouse, six locomotives, a number of freight cars and a large amount of stores, including fuel oil, were destroyed, the total loss being estimated at several hundred thousand dollars.

Director-General McAdoo has addressed to the railroads a questionnaire asking information concerning the use of varnish on cars and locomotives during the calendar year 1917. Reports must show the brand, vendor, manufacturer, amount used for various purposes, total cost and price per gallon.

Obsolete or obsolescent locomotives may be useful somewhere, and Director-General McAdoo has addressed a circular letter to the presidents of Class I railroads asking for information regarding all locomotives which are not in service by reason of age, condition, size, weight, etc., but which, if in good condition or properly repaired, could be used to advantage on roads of less traffic density or more favorable operating conditions.

In order to give some recognition to men who have helped to build up its record of efficiency, the Canadian Pacific has decided to name certain of the Canadian Pacific locomotives after the engineers who, by meritorious conduct or by acts of special bravery have, in the opinion of the management, earned the right to special distinction. It is not the intention to name every locomotive at once, but only those in passenger service, and to keep each name as a privilege and a reward.

In an explosion and fire at the Jarvis warehouse, Jersey City, N. J., on March 26, the repair shops of the Erie Railroad, on the north side of the main line near the Jersey City passenger station, were destroyed; estimated loss, \$300,000; loaded freight cars to the value of \$200,000 (estimated) were also destroyed. The explosion caused, altogether, damage to the amount of about \$1,500,000, and fire brands were blown across the river to New York, damaging the Erie station and ferry-house. It is understood that the company will not rebuild on the same site.

A shortage of passenger cars is reported by the Pennsylvania Railroad. This unusual condition has arisen in connection with the rapid growth of war industries in the section between Philadelphia and Baltimore. Special trains are run daily to and from such industries in six localities which require the use of 215 cars. In addition, 15 cars daily will be required soon for further special industrial service in this locality. In order thus to provide for these essential war industries, it has been necessary to limit the length of some suburban trains in the neighborhood of Philadelphia and Baltimore.

The mining of clean coal is to be enforced by the Fuel Administration, according to an announcement which has recently been made. An inspection system will be organized Under the new plan adopted, coal condemned by the Fuel Administration, either lacking preparation or because it contains a high percentage of impurities, will be sold at 50 cents a ton less than the fixed Government price for the mine. The inspection system will be operated through the district representatives of the Fuel Administration, who are authorized to appoint a sufficient number of inspectors to carry out the terms of the order, which went into effect on Monday, March 11.

The Pennsylvania Railroad has issued a pamphlet containing brief articles by a dozen or more employees of the road, telling from their own experiences, how railroad men may make themselves efficient in the duty of helping to win the war. These writers are Edward F. McKenzie, locomotive engineer; Wm. Parker, car repairman; T. T. Buck, engineer; S. C. Lowrey, engineer; U. S. Shearer, engineer; John Phelan, track foreman; H. S. Meyer, engineer; H. P. Peterson, engineer; H. E. Emery, station agent; Emanuel Shepp, track foreman; Hugh Mulloy, track foreman; H. F. Krcar, engineer; Thomas M. Finn, engineer, and P. L. Smith, fireman.

The director-general has announced the creation of a Car Repair Section, and an Inspection and Test Section of the Division of Transportation. The former will be in charge of J. J. Tatum, superintendent of the freight car repair department of the Baltimore & Ohio, as manager, with office in the Southern Railway building, Washington, D. C. The manager of the section will supervise the condition of and repairs to freight and passenger cars in all existing railway

shops, and at outside shops. C. B. Young, mechanical engineer of the Chicago, Burlington & Quincy, has been appointed manager of the Inspection and Test Section, with office in the Southern Railway building, Washington, D. C. He will have charge of the test and inspection of materials and work in connection with the construction of standard locomotives and cars.

The President has approved the recommendation of the price-fixing committee of the War Industries Board that the maximum prices heretofore fixed by the President upon the recommendation of the board upon ore, coke, steel and steel products, subject to revision on April 1, 1918, be continued in effect until July 1, 1918; from April 1 to July 1, however, the maximum price of basic pig iron be reduced from \$33 to \$32 per gross ton, and that the maximum price of scrap steel be reduced from \$30 to \$29 per gross ton. No new contracts calling for delivery of any of said commodities or articles on or after July 1, 1918, are to specify a price unless coupled with a clause making the price subject to a revision by any authorized United States Government agency.

Frank McManamy, manager of the Locomotive Section of the United States Railroad Administration, has appointed the following railroad officers as a consulting board to consider matters relative to the maintenance of locomotives, the distribution of locomotives to various shops for repairs, shop production and practices, and other matters of a similar character: H. T. Bentley, superintendent of motive power, Chicago & North Western; C. E. Chambers, superintendent of motive power, Central of New Jersey; C. E. Fuller, superintendent of motive power, Union Pacific; J. Hainen, assistant to the vice-president, Southern; D. R. MacBain, superintendent of motive power, New York Central Lines West; John Purcell, assistant to the vice-president, Atchison, Topeka & Santa Fe.

Announcement has been made of the personnel of Railway Board of Adjustment No. 1 created by the Railroad Administration to deal with controversies between the railroads and the organizations of train service employees growing out of the interpretation or application of the provisions of wage schedules or agreements. The board will consist of four representatives of the railroads and four officers of the brotherhoods, as follows: E. T. Whiter, assistant general manager of the Pennsylvania, Western Lines; J. G. Walber, secretary of the Bureau of Information of the Eastern Railroads; J. W. Higgins, executive secretary of the Association of Western Railroads; C. P. Neill, manager of the Bureau of Information of the Southeastern Railroads; L. E. Sheppard, vice-president, Order of Railway Conductors; F. A. Burgess, assistant grand chief, Brotherhood of Locomotive Engineers; Albert Phillips, vice-president, Brotherhood of Locomotive Firemen and Enginemen, and W. N. Doak, vice-president, Brotherhood of Railroad Trainmen. The board will hold a meeting at Washington on Monday to organize and will proceed immediately to consider a number of pending disputes.

Thirty-Seventh Regiment Electrical Engineers, Being Recruited

A regiment of electrical engineers is being recruited in Chicago as rapidly as possible for service in France. The selection of non-commissioned officers has not been made and the men who enlist will have chances for these places. Men who are skilled in the following trades will be enlisted: Cooks, machinists, blacksmiths, metal workers, foundrymen, patternmakers, plumbers, electricians, pipe fitters, draftsmen, storemen, carpenters, welders, boilermakers, bricklayers, masons, chauffeurs, handymen and linemen. The regiment will also need operators of oil, steam and gasoline engines and electrically driven pumps. The regiment will be known as the 37th Engineers, and will be commanded by Colonel Theodore A. Dillon, an officer of the Engineering Corps of the Regular Army, who has been relieved from duty as electrical engineer of the Panama Canal to command this regiment. A special recruiting office has been opened at 120 West Adams street, Chicago, in charge of Major Arthur B. Kratz, Engineer Officers' Reserve Corps, also formerly on the Panama Canal.

Railway Regiments' Thanks for Tobacco

A number of letters have been received expressing the appreciation of the men in the railway regiments now in France for the tobacco which they have received as a result of the contributions to the Railway Regiments' Tobacco Fund, by railway supply companies in the United States. C. W. Kutz, colonel commanding the Thirteenth Engineers, writing on March 1, says:

"Ever since December 21, when I acknowledged receipt of your letter, we have been on the lookout for the shipment of tobacco which you had made. Yesterday our patience was rewarded by the receipt of three cases of smoking tobacco.

The members of this regiment feel very fortunate in having such friends as the contributors to the 'Railway Regiments' Tobacco Fund,' and hope by their actions to fully justify the interest of their friends in the United States.

Major John A. Laird, commanding the 12th Engineers, writing on February 27, expresses similar hearty thanks for three cases received on February 26.

V. J. Jaeger, Co. F, 13th Engineers, writing on March 4, acknowledges receipt of the first consignment of "generosity" from the Railway Supply Companies' Fund. "Words fail to express our appreciation. The smokes are the answer to our difficulties and a solace to the ills engendered in dovetailing railroading with the military end of this war game. In the language of our French comrades we simply say 'Je vous remercie.'"

Col. W. P. Wooten, of the 14th Engineers, acknowledging receipt of three cases of tobacco, sends thanks to the donors and says that the men's enjoyment of the gift has been great.

During the past month one new subscription to the Railway Regiments' Tobacco Fund for \$10 a month for 12 months was received from the Rome Iron Mills, Inc., New York; a donation of \$20 was made by the McConway &

RAILROAD CLUB MEETINGS

Club	Next Meeting	Title of Paper	Author	Secretary	Address
Canadian	Apr. 9, 1918	Freight Brake Maintenance	F. B. Farmer	James Powell	P. O. Box 7, St. Lambert, Que.
Central	May 10, 1918	Radiant Heat and Locomotive Design	J. T. Anthony	Harry D. Vought	95 Liberty St., New York.
Cincinnati	May 12, 1918			H. Boutet	101 Carew Bldg, Cincinnati, Ohio.
New England	Apr. 9, 1918	Brake Conditions in General Freight Service and Their Relation to Shocks and Breaks-in-two	H. F. Wood	W. E. Cade, Jr.	683 Atlantic Ave., Boston, Mass.
New York	Apr. 19, 1918	Thermit Welding; Illustrated with Moving Pictures	R. L. Browne	Harry D. Vought	95 Liberty St., New York.
Pittsburgh	Apr. 26, 1918			M. J. Hepburn	102 Penn. Station, Pittsburgh, Pa.
St. Louis	Apr. 12, 1918	Another "Scrap of Paper"; Annual Reports and Election of Officers	Hon. James C. Jones	B. W. Frauenthal	Union Station, St. Louis, Mo.
Western	Apr. 15, 1918			Joseph W. Taylor	1112 Karpen Bldg., Chicago.

Torley Company of Pittsburgh, and a second contribution of \$100 was received from the Chicago Railway Equipment Company, Chicago.

United States Government Locomotives

Specifications have been prepared by the Railroad Administration for eight types of locomotives:

- Light and heavy mountain types.
- Light and heavy Mikado types.
- Light and heavy Pacific types.
- Six-wheel and eight-wheel switching locomotives.

The director-general will determine the number of each type which will be ordered for use in the different regions. The proposed standard specifications for locomotives, although still subject to slight revisions, were given to locomotive builders some time ago and they have submitted their prices, which are being carefully scrutinized and checked. If the costs for any item seem high, the reason for it will be ascertained, and if necessary the Government will arrange to purchase certain materials for builders where it can do so more cheaply. A meeting was held at Washington on April 1 with the manufacturers of locomotive specialties to consider informally the specialties to be used on the standard locomotives to be ordered. A similar meeting will be held shortly with the manufacturers of car specialties. Detailed prices on the cars have been received and will be checked before a decision is reached as to the number of each type to be ordered.

MEETINGS AND CONVENTIONS

Electric Hoist Manufacturers' Association.—This association was recently formed by manufacturers of electric hoists in the United States for the purpose of co-ordinating the total experience of the various manufacturers and to make available for the user all that is best in electric hoist design. The membership of the association is confined to those engaged in the manufacture of monorail electric hoists. The officers of the association are: H. A. Hatch, chairman, Shepard Electric Crane & Hoist Company; F. W. Hall, vice-chairman, Sprague Electric Works, and C. W. Beaver, secretary-treasurer, Yale and Towne Manufacturing Company.

The following list gives names of secretaries, dates of next or regular meetings and places of meeting of mechanical associations:

- AIR BRAKE ASSOCIATION.—F. M. Nellis, Room 3014, 165 Broadway, New York City. Convention May 7 to 10, 1918, Cleveland, Ohio.
- AMERICAN RAILROAD MASTER TINNERS', COPPERSMITHS' AND PIPEFITTERS' ASSOCIATION.—O. E. Schlink, 485 W. Fifth St., Peru, Ind.
- AMERICAN RAILWAY MASTER MECHANICS' ASSOCIATION.—J. W. Taylor, Karpen Bldg., Chicago.
- AMERICAN RAILWAY TOOL FOREMEN'S ASSOCIATION.—R. D. Fletcher, Belt Railway, Chicago.
- AMERICAN SOCIETY FOR TESTING MATERIALS.—Prof. E. Marburg, University of Pennsylvania, Philadelphia, Pa. Annual meeting June 25-28, 1918, Hotel Travmore, Atlantic City, N. J.
- AMERICAN SOCIETY OF MECHANICAL ENGINEERS.—Calvin W. Rice, 29 W. Thirty-ninth St., New York.
- ASSOCIATION OF RAILWAY ELECTRICAL ENGINEERS.—Joseph A. Andreucetti, C. & N. W., Room 411, C. & N. W. Station, Chicago.
- CAR FOREMEN'S ASSOCIATION OF CHICAGO.—Aaron Kline, 841 Lawlor Ave., Chicago. Second Monday in month, except June, July and August, Hotel Morrison, Chicago.
- CHIEF INTERCHANGE CAR INSPECTORS' AND CAR FOREMEN'S ASSOCIATION.—W. R. McBurn, New York Central, Albany, N. Y.
- INTERNATIONAL RAILROAD MASTER BLACKSMITHS' ASSOCIATION. A. L. Woodworth, C. H. & D., Lima, Ohio.
- INTERNATIONAL RAILWAY FUEL ASSOCIATION.—J. G. Crawford, 547 W. Jackson Blvd., Chicago.
- INTERNATIONAL RAILWAY GENERAL FOREMEN'S ASSOCIATION.—William Hall, 1126 W. Broadway, Winona, Minn.
- MASTER BOILERMAKERS' ASSOCIATION.—Harry D. Vought, 95 Liberty St., New York.
- MASTER CAR BUILDERS' ASSOCIATION.—J. W. Taylor, Karpen Bldg., Chicago.
- MASTER CAR AND LOST MOTIVE PARTS ASSOCIATION OF U. S. AND CANADA.—A. P. Dane, B. & M., Reading, Mass.
- NIAGARA FRONTIER CAR MEN'S ASSOCIATION.—George A. J. Hochrhebe, 623 Brisbane Bldg., Buffalo, N. Y. Meetings, third Wednesday in month, Staler Hotel, Buffalo, N. Y.
- RAILWAY STOREKEEPERS' ASSOCIATION.—J. P. Murphy, Box C, Collinwood, Ohio.
- TRAVELING ENGINEERS' ASSOCIATION.—W. O. Thompson, N. Y. C. R. R., Cleveland, Oh. Next meeting, September 10, 1918, Chicago.

PERSONAL MENTION

GENERAL

W. F. ACKERMAN, shop superintendent of the Chicago, Burlington & Quincy, at Havelock, Neb., was appointed acting superintendent of motive power of the lines west of the Missouri river, succeeding T. Roope, granted leave of absence.

E. C. ANDERSON, mechanical engineer of the Colorado & Southern, with headquarters at Denver, Colo., has been appointed assistant mechanical engineer of the Chicago, Burlington & Quincy, with office at Chicago.

H. P. ANDERSON, mechanical engineer of the Missouri, Kansas & Texas of Texas, was appointed superintendent of motive power, with headquarters at Denison, Tex., succeeding F. W. Taylor.

B. J. PEASLEY, whose appointment as mechanical superintendent of the St. Louis-Southwestern of Texas, with office at Tyler, Tex., was announced in the February issue, was



B. J. Peasley

born at Decorra, Ill., on December 21, 1867. He entered railway service at the age of 16 as laborer and machinist apprentice with the Chicago, Burlington & Quincy, at West Burlington, Ia. On completing his apprenticeship he entered Elliott's Business College, at Burlington, Ia. After completing the business course he again entered railway service as a machinist with the Atchison, Topeka & Santa Fe, at Ft. Madison, Ia. In 1894 he was employed

by the Ft. Madison Gas & Gasoline Engine Company; from 1895 to 1899 he was employed by the Chicago, Ft. Madison & Des Moines, as fireman and engineer. From 1899 to 1901 he was employed by the Illinois Central, at East St. Louis, Ill., as a machinist and was later promoted to division and wrecking foreman, at Carbondale, Ill. In 1901 he entered the service of the Denver & Rio Grande, as roundhouse foreman at Helper, Utah, where he remained a short time, returning to the Illinois Central, at East St. Louis, Ill., where he served in the capacity of roundhouse foreman, shop foreman and general foreman until September, 1906. He was appointed general foreman of the Missouri Pacific, at Bixby, Ill., in September, 1906, and was later promoted to master mechanic, at Ferriday, La., where he remained for six months and was then transferred to De Soto, Mo., as master mechanic of the Missouri division. In February, 1914, he was promoted to superintendent of shops at Argenta, Ark., where he remained until promoted, as noted above.

WALTER U. APPLETON, general master mechanic of the Canadian Government Railways, with office at Moncton, N. B., has been appointed superintendent motive power with office at Moncton, succeeding G. R. Joughins, who was superintendent of rolling stock. Mr. Appleton was born on January 29, 1878. On October 13, 1890, he obtained a position with the Canadian Government Railways as a junior clerk

in the insurance office and worked there until 1894, when he secured a transfer to the locomotive department as machinist apprentice. On the completion of his apprenticeship he was transferred to the office of the superintendent motive power as a clerk, after which he was employed in the shop for one year as machinist. In 1903 he was promoted to the position of chief clerk to the superintendent motive power and was appointed assistant superintendent motive power in 1909. In 1913 he was appointed general master mechanic.

F. W. TAYLOR, superintendent of motive power of the Missouri, Kansas & Texas, with headquarters at Denison, Tex., has been appointed general manager, with headquarters at Parsons, Kan., succeeding H. F. Anderson, who was transferred to San Antonio, Tex., as superintendent of terminals of the Missouri, Kansas & Texas of Texas.

R. A. WINSER, engineer of tests and fuel inspector of the Chicago & Alton, with headquarters at Bloomington, Ill., resigned on April 1.

W. H. WINTERROWD, assistant chief mechanical engineer of the Canadian Pacific, has been appointed chief mechanical engineer to succeed W. E. Woodhouse, who has resigned. His headquarters are at Montreal, Que.

MASTER MECHANICS AND ROAD FOREMEN OF ENGINES

WILLIAM EARLE BARNES, master mechanic of the Canadian Government Railway at Moncton, N. B., has been appointed general master mechanic, succeeding W. U. Appleton, with headquarters at Moncton, N. B. He was born on July 24, 1879, at Shediac, N. B., and was educated in the public schools. He began railway work on April 20, 1899, as draftsman apprentice on the Canadian Government Railways. In 1902 he served as draftsman, and in 1906 first as machinist and later as draftsman. In October, 1907, he was appointed fitter and in January, 1909, again served as draftsman. In April, 1910, he was appointed enginehouse inspector and the following January became acting master mechanic. He was appointed master mechanic in September, 1912, and since August, 1917, was acting general master mechanic until his recent appointment as general master mechanic as above noted.

ARTHUR CROHN has been appointed general master mechanic of the Missouri, Kansas & Texas, with headquarters at Denison, Tex.

C. O. DAVENPORT, road foreman of engines of the Chicago, Burlington & Quincy, with office at Alliance, Neb., has been appointed master mechanic, with office at Sterling, Colo., succeeding G. O. Hockett.

T. DEVANEY has been appointed master mechanic of the Toledo, St. Louis & Western, with office at Frankfort, Ind.

J. L. FAGAN, master mechanic of the Denver & Rio Grande at Grand Junction, Colo., has been appointed master mechanic of the fourth division, with headquarters at Alamosa, Colo., succeeding H. C. Stevens.

G. O. HOCKETT, master mechanic of the Chicago, Burlington & Quincy, with office at Sterling, Colo., has been appointed master mechanic, with office at Alliance, Neb., succeeding J. G. Dole, resigned.

T. W. McBEATH, traveling fireman of the Canadian Government Railways, with office at Moncton, N. B., has been appointed master mechanic, with headquarters at Moncton.

F. T. OWENS, assistant master mechanic of the Denver & Rio Grande, at Pueblo, Colo., has been appointed master mechanic, with office at Grand Junction, Colo., succeeding J. L. Fagan.

CHARLES RAITT, whose appointment as master mechanic of the Atchison, Topeka & Santa Fe Coast Lines at Needles, Cal., was noted in the March issue, was born on January 16, 1862, at Montrose, Scotland. His railroad service dates from 1882, when he obtained employment with the Canadian Pacific as a machinist. In 1887 he secured a position as gang foreman with the Chicago & Atlantic at Huntington, Ind., where he remained until 1889, when he went with the Northern Pacific as machinist at Brainerd, Minn., and was later promoted to general foreman. He was next with the Canadian Northern as general foreman and master mechanic at Winnipeg, Man., until the latter part of 1902, and was then employed by the Great Northern on air brake department work at St. Paul until 1904. He has been with the Atchison, Topeka & Santa Fe since that time, first as erecting shop foreman at Albuquerque, N. M., and from 1908 until he received his recent appointment, he was general locomotive foreman at Richmond, Cal.

F. W. SCHULTZ, master mechanic of the Kansas City, Mexico & Orient of Texas at San Angelo, Texas, has also been assigned the duties of superintendent motive power and car departments of the Kansas City, Mexico & Orient, the latter office having been abolished. In addition to headquarters at San Angelo, he will maintain office at Wichita, Kans.

W. B. STOKES has been appointed master mechanic of the Wrightsville & Tenuille, with headquarters at Tenuille, Ga., succeeding M. G. Brown.

SHOP AND ENGINEHOUSE

THOMAS B. DICKERSON has been appointed acting superintendent of shops of the Central of New Jersey, with office at Elizabethport, N. J., succeeding G. L. Van Doren, resigned.

H. C. STEVENS, master mechanic of the Denver & Rio Grande at Alamosa, Colo., has been appointed superintendent of shops at Burnham (Denver), Colo.

PURCHASING AND STOREKEEPING

W. F. LAMB has been appointed division storekeeper of the Southern Railway, with office at South Richmond, Va., succeeding J. E. Angel, promoted.

THOMAS SPRATT, assistant purchasing agent of the Norfolk & Western, with office at Roanoke, Va., will perform the duties of purchasing agent.

W. F. WRIGHT has been appointed assistant to the purchasing agent of the Louisiana & Arkansas, with office at Texarkana, Ark.

A. H. YOUNG, tie and timber agent of the Seaboard Air Line, with office at Hamlet, N. C., has been appointed general storekeeper, with office at Portsmouth, Va., succeeding D. D. Cain, resigned to accept service with another company.

OBITUARY

WILLIAM C. KENT, general foreman of the Georgia Southern & Florida at Valdosta, Ga., died on March 28, 1918.



William Earle Barnes

SUPPLY TRADE NOTES

A. J. BEUTER, representative of the Baldwin Locomotive Works at San Francisco, Cal., has been transferred to Portland, Ore.

W. S. BARTHOLOMEW, president of the Locomotive Stoker Company, has been elected vice-president of the Westinghouse Air Brake Company in direct charge of the activities



W. S. Bartholomew

representative at Boston, Mass. He remained here until 1905 when he was made western manager of the same company at Chicago. He was transferred in 1913 to the Locomotive Stoker Company, being elected president, and ever since has actively directed the development of the Street stoker and its distribution to the railroads throughout the country. In addition to his new position he still retains his former office of president of the Locomotive Stoker Company.

W. D. HORTON, circulation manager of the Simmons-Boardman Publishing Company, publishers of the *Railway Mechanical Engineer*, resigned on March 1 to accept a position



W. D. Horton

as district railway sales manager of the Patton Paint Company with headquarters at Milwaukee, Wis. Mr. Horton was born in Brooklyn, N. Y., December 3, 1880, and was educated in the public schools of that city. On June 1, 1908, he joined the staff of the Simmons-Boardman Publishing Company, and from 1908 to 1914 acted as a traveling subscription representative, on April 1, 1914, being appointed circulation manager.

Mr. Horton has had a wide selling experience, having spent several years, previous to 1908, selling various commodities such as stationary engines, boilers, wood-working and other machinery. In this work he traveled extensively throughout the United States,

Canada, Mexico, Cuba, the West Indies, and in South and Central America. As circulation manager, he obtained a wide personal acquaintance among executive officers and department heads of nearly all the railways in the United States and Canada.

THE UNITED STATES RUBBER COMPANY recently announced the purchase of the plant of the American Locomotive Company at Providence, R. I.

The BETTENDORF COMPANY has waived its patent rights on truck sides and underframes for the duration of the Government control of the railroads.

RICHARD W. BAKER, superintendent of outside construction of the Watson-Stillman Company, New York, died on March 24 at his home in Roselle, New Jersey. Mr. Baker was 68 years of age.

The H. W. JOHNS-MANVILLE COMPANY advises that its office in Memphis, Tenn., has been removed to 804-805 Exchange building, at Madison Avenue and Second Street in that city.

The ASBESTOS PROTECTED METAL COMPANY, Pittsburgh, announces the appointment of HERBERT LONGSTAFF as manager of its St. Louis office, located in the Boatman's Bank building.

R. J. HIMMELRIGHT has been elected vice-president of the American Arch Company. In his new position Mr. Himmelright will have charge of the service and road develop-



R. J. Himmelright

ment work in the United States and Canada. Mr. Himmelright was born at Wadsworth, Ohio, and received his grammar and high school education at that place. Upon leaving high school he attended Wooster University for two years as a special student. Completing this work he entered Purdue University, graduating with the degree of mechanical engineer. While at Purdue University he specialized in railroad work. Immediately upon graduation he entered

the service of the Lake Shore & Michigan Southern as a special apprentice. His work with the Lake Shore, while wholly in the mechanical department, covered a wide and varied field and gave him unusual opportunity to study locomotive operation. Leaving the Lake Shore he entered the service of the Locomotive Stoker Company as mechanical expert. In 1913 he accepted a position with the American Arch Company as traveling engineer and was made successively assistant to the manager of the service department and manager of the service department, which position he held at the time of his recent election.

COLONEL HENRY P. BOPE has resigned his position as vice-president and general manager of sales of the Carnegie Steel Company, effective April 1, 1918. He has been succeeded by WILLIAM G. CLYDE.

W. O. DUNTLEY, president of the Chicago Pneumatic Tool Company, Chicago, resigned on April 1. He will retain his interest in the company and will also remain a director and a member of the executive committee, and will continue to assist in an advisory capacity. No successor to Mr. Duntley

has been elected, but J. G. Osgood, first vice-president, will act as president.

FRANK J. HURLEY, who for a number of years was a representative connected with the New York office of the Independent Pneumatic Tool Company, died in East Orange, N. J., March 10, at the age of 29 years.

THE PERMUTT COMPANY, manufacturers of water softening and water rectification apparatus and for several years past located at 30 East Forty-second Street, New York, has announced the removal of its headquarters to 440 Fourth Avenue.

THE GALENA SIGNAL OIL COMPANY is to establish a large manufacturing and distributing plant at Houston, Texas, having bought the refinery and pipe lines of J. S. Cullinan for a consideration said to approximate \$10,000,000.

R. S. COOPER, who for several years had been in charge of the New York office of the Independent Pneumatic Tool Company, has been elected vice-president and general sales manager. He will have his headquarters in the Thor building, Chicago.

ROBERT E. FRAME, for the past six years assistant to the president of the Haskell & Barker Car Company, Michigan City, Ind., resigned on March 1, and has been elected vice-president of the Hutchins Car Roofing Company, with office in Detroit, Mich.

W. F. WAGNER, after 52 years' service, has severed his connection with William Jessop & Sons and now has become sales manager of the Seaport Steel Company. This company specializes in the manufacture of carbon tool steel and forgings, high-speed steel, alloy and carbon sheet steel and all varieties of high-grade steel.

H. D. SAVAGE has been elected vice-president of the Locomotive Pulverized Fuel Company. He will also continue as vice-president of the American Arch Company. Mr. Savage was born at

Memphis, Tenn. He was educated in the public schools at Ashland, Ky., and at the Kenyon Military Academy. He started his business life with the Ashland Fire Brick Company in the manufacturing department, serving in various capacities. Later he was appointed manager of sales, and during his ten years in this position he made great strides towards putting the manufacture of high grade refractories on a scientific basis. He was largely instrumental in making Ashland the most modern brick plant in the country at that time, introducing many features making for uniformity of product and increased output. Together with the late E. S. Hitchens he organized the Refractory Manufacturers' Association, of which he was elected the first president. This association includes in its membership practically all the manufacturers and users of refractory materials. Mr. Savage's work as sales manager gave him opportunity to thoroughly study the application of refractories to the metallurgical field, and he enjoys a wide acquaintance in the metallurgical industry of this country. In 1914 he was elected vice-president of the American Arch



H. D. Savage

Company in charge of manufacturing. In this position he organized the manufacturing department of this company so that close supervision by trained inspection is given the fire brick at the Arch company's plants. This resulted in higher grade brick and greater service life. In 1917, in addition to his duties as vice-president of the American Arch Company he was appointed manager of sales of the Locomotive Pulverized Fuel Company.

J. L. PRICE, assistant to the chairman of the board of directors of the Chicago Pneumatic Tool Company, Chicago, was recently elected vice-president in charge of finances. He was also re-elected assistant to the chairman of the board of directors and in that capacity will continue to act as the representative of the chairman.

GEORGE W. WILDIN has resigned as general manager of the New York, New Haven & Hartford to enter the employ of the Westinghouse Air Brake Company as general manager of the Locomotive Stoker Company, with headquarters at Pittsburgh, Pa. He brings to his new position extensive railroad experience and a well rounded out mechanical and managerial career. Born at Decatur, Ill., February 28, 1870, he studied at the city schools and was graduated from the Kansas State Agricultural College in June, 1892, with the degree of Bachelor of Science. He entered railway service shortly afterwards as mechanical



George W. Wildin

draftsman in the Topeka shops of the Atchison, Topeka & Santa Fe. He subsequently became a machinist and a locomotive fireman on the Santa Fe and later an engineer on the Mexican Central. Leaving railway service he was for a time superintendent of the Aermotor Company, of Chicago. He soon returned to railway service, however, as an engineer on the Chicago & Alton, and then went to the Plant System, now a part of the Atlantic Coast Line, where he served successively as a machinist, locomotive and car inspector and as mechanical engineer. From April 1, 1901, to March 1, 1904, he was mechanical engineer for the Central Railroad of New Jersey. On March 1, 1904, he left that company to become assistant mechanical superintendent of the Erie, being promoted on April 1 of the same year to mechanical superintendent at Meadville, Pa. From January to July, 1907, he served as assistant superintendent of motive power of the Lehigh Valley, and then left that road to accept the position as mechanical superintendent of the New Haven. In May, 1917, he was promoted to general mechanical superintendent, and in September of the same year was again promoted to the position of general manager. Mr. Wildin was president of the American Railway Master Mechanics' Association in 1910.

PAUL T. IRVIN, who has been associated with the Wells Brothers Company, and the Greenfield Tap & Die Corporation for 12 years, has resigned his position as sales manager of the gage division to accept the position of general sales manager of Lincoln Twist Drill Company, of Taunton, Mass. EDWARD BLAKE, JR. (formerly of Wells Brothers Company), is vice-president and general manager of this company, and FRANK O. WELLS, president, and FREDERICK H. PAYNE,

vice-president of the Greenfield Tap & Die Corporation, are directors.

ERNEST BAXTER, general storekeeper of the Wabash, with office at St. Louis, Mo., resigned on March 1, to become manager of railroad sales for the Kansas City Bolt & Nut Company, with office in Kansas City, Mo. A photograph and biographical sketch of Mr. Baxter's business career appeared on page 364 of the June, 1917, issue of the *Railway Mechanical Engineer*.

G. R. LEWIS, division freight agent of the Cleveland, Cincinnati, Chicago & St. Louis, with headquarters at Indianapolis, Ind., and for more than twenty years with the New York Central Lines, has been appointed manager of supplies and traffic, with the Standard Forgings Company of Indiana Harbor, Ind. He will have offices in the Railway Exchange building, Chicago.

W. L. REID has been elected vice-president and general manager of the Lima Locomotive Works, Inc., with offices at Lima, Ohio. Mr. Reid was born at Paterson, N. J.



W. L. Reid

His entire business life has been connected with locomotive building. He served his apprenticeship in the drawing office and shops of the Rogers Locomotive & Machine Works at Paterson and became successively erecting shop foreman, assistant superintendent and superintendent of the same plant. Leaving the Rogers works he was appointed assistant superintendent of the Brooks Locomotive Works, and two years later superintendent of the Brooks works.

After serving only 20 days in the latter position he was appointed superintendent of the Schenectady works of the American Locomotive Company. He was later appointed manager of the Schenectady plant and general works manager of the American Locomotive Company. Resigning from the American Locomotive Company, he became general manager of the National Brake & Electric Company, Milwaukee, Wis. Six months later he resigned to become general superintendent of the Baldwin Locomotive Works at Eddystone, which position he held up to the time of his recent election.

IRA C. ROGERS, formerly general purchasing agent for the Worthington Steam Pump Company at New York, has been appointed general manager of W. R. Keene & Co., also of New York. W. R. Keene & Co. represent the Bay State Tap & Die Company, Alvord Reamer & Tool Company, Sterling Products Company, Keene Twist Drills and Massey Vise Company.

G. W. BICHLMIER has recently become associated with the machinery department of the Walter A. Zelnicker Supply Company, St. Louis, Mo. Mr. Bichlmier was formerly associated with the supply departments of the Missouri Pacific and Kansas City Southern and was secretary-treasurer of the W. L. Sullivan Machinery Company.

In the semi-annual report of the AMERICAN LOCOMOTIVE COMPANY, which was recently published, it was stated that the Richmond and Montreal plants of the company, which had been engaged exclusively on munitions work since 1915,

finished their munitions work last year and the work of restoring those plants for locomotive manufacture was completed during October, 1917.

THE CHICAGO PNEUMATIC TOOL COMPANY is doing four times as much business as in the pre-war period, according to its annual report for the year ended December 31, 1917, recently made public. In addition, the net profits have exceeded those of any previous year, even after providing for an additional tax of 4 per cent on the company's net income and for the excess profits war tax. The company's plants have been taxed to capacity to fill the orders which have been received and it has been necessary to make improvements and additions to the plant.

LOYALL A. OSBORNE, vice-president of the Westinghouse Electric & Manufacturing Company, and chairman of the executive committee of the National Industrial Conference Board, has been appointed by the Secretary of Labor a member of a committee on industrial peace during the war. This committee, which consists of five representatives of employers, five labor leaders, and two public men, will provide a definite labor program in order that there may be industrial peace during the war, thus preventing interruption of industrial production vital to the war.

H. J. TIERNEY, president of the Tierney Supply & Lumber Company, Chicago, has been appointed representative for the Grip Nut Company, Chicago, with office at 1742 Railway Exchange building, St. Louis, Mo. Mr. Tierney began railway service with the Missouri, Kansas & Texas, on March 5, 1888, as apprentice coppersmith. He was appointed mechanical engineer in 1907, and was promoted to superintendent of the car department in January, 1916, with headquarters at Denison, Texas, which position he resigned on January 1, 1918, to become president of the Tierney Supply & Lumber Company.

KARL J. EKLUND has been appointed general manager of Mudge & Co., in charge of the engineering and manufacturing departments, with headquarters at Chicago. Mr.



Karl J. Eklund

Eklund was born on July 8, 1884, and was educated in the grammar and high schools of Keene, N. H. He started his railroad service as a blacksmith helper in the Boston & Maine shops, and from March, 1903, to April, 1906, served his apprenticeship as machinist on that railroad. During the next two years he was employed on various railroads as journeyman machinist, and in 1908 returned to the Boston & Maine as machinist and foreman in the

Keene, N. H., shops. On March 1, 1910, he left the service of this road to accept a position with the Pilliod Company, of New York and Swanton, Ohio, as Baker valve gear inspector, and on February 1, 1915, he was appointed assistant to the president of the Pilliod Company, with headquarters at New York. He occupied this position until April 1, 1917, when he was appointed assistant to the president of Mudge & Co., Chicago, the western representatives for the Pilliod Company, and served in this capacity until his appointment as general manager on March 1, 1918. In this capacity he will con-

tinue to direct the service departments of the Pilliod Company and the Chambers Valve Company, both of whom are represented in the west by Mudge & Co. He will also have charge of the service department of Mudge & Co. in addition to the engineering and manufacturing departments.

W. L. ROBINSON, supervisor of fuel consumption, Baltimore and Ohio, has resigned to accept a position in the operating department of the E. I. du Pont de Nemours Company, Wilmington, Del. Mr. Robinson is one of the best-informed men in railway fuel matters and is at the present time vice-president of the International Railway Fuel Association and the Smoke Prevention Association.

American Car & Foundry Company

A. E. OSTRANDER, mechanical engineer at the New York office of the American Car & Foundry Company, has been made general mechanical engineer, and will have general supervision over all mechanical matters, reporting to J. M. BUICK, vice-president and general manager. Mr. Ostrander's promotion has made necessary a number of other changes in the engineering department, the more important of which are as follows: H. C. LUNGER has been made assistant to the general mechanical engineer with headquarters at New York. FRED G. WOLFF has been made mechanical engineer, with headquarters at St. Louis, Mo. NORMAN LITCHFIELD has been made mechanical engineer, with headquarters at New York. JOHN G. McBRIDE has been made engineer of car construction, with headquarters at New York, and will report direct to the general mechanical engineer. H. P. FIELD has been made assistant engineer, with headquarters at Berwick, Pa., and will report to the engineer of car construction. W. L. YOCUM has been appointed assistant engineer, with headquarters at Chicago, and H. D. DISTELHURST, assistant engineer, with headquarters at Washington. W. H. SELDEN and J. D. THOMPSON have been made assistant engineers, with headquarters at New York, and W. J. ROA, assistant engineer, with headquarters at St. Louis, Mo.

Mr. Ostrander was born and educated in New Haven, Conn., and during his school vacations worked in various departments of the New York, New Haven & Hartford. He entered the drawing room of the New Haven in 1897 and was later employed by CORNELIUS VANDERBILT in designing cars, car trucks and other railway appliances. For a time he worked as a car designer and checker for the Standard Steel Car Company at Pittsburgh, and in September, 1902, entered the service of the American Car & Foundry Company at New York and was successively employed as designer, estimator, and chief estimator. In February, 1904, he was made assistant mechanical engineer, and on October 1, 1915, was promoted to the position of mechanical engineer at the New York office. He has been closely identified with the development of steel cars and especially steel passenger cars. Since the outbreak of the war, he has given considerable time to special work for the Government and has served on the committee of engineers from car building companies that has been engaged in designing the standard freight equipment for the United States Government.



A. E. Ostrander

CATALOGUES

JOURNAL PACKING.—A new kind of car waste that is kept elastic and in contact with the journal by means of interwoven brass spring wire is described in a pamphlet issued by the Elastic Car Waste Company, Philadelphia, Pa.

REINFORCING BARS.—The Cambria Steel Company, Philadelphia, has issued a 24-page illustrated booklet describing the Cambria slick concrete reinforcing bar. This booklet contains detailed information concerning the properties of this bar and data of value in designing structures in which it is to be used.

TOOL HOLDERS.—Under the title of "How to Save Money on High Speed Steel," the Gisholt Machine Company, Madison, Wis., has issued a pamphlet showing three kinds of tool holders which may be used to advantage with high speed tool bits made by drawing out pieces of high speed steel which would otherwise have been scrapped.

MILLING CUTTERS.—The "Stock List of Cutters" issued by the Cleveland Milling Machine Company, Cleveland, Ohio, under the date of March 15, 1918, contains a list of the different kinds and sizes of milling cutters made by that company. Various kinds of angular cutters, end mills, slotting and concave cutters are also listed.

ACETYLENE WELDING.—A four-page leaflet has been issued by the Alexander Milburn Company, Baltimore, Md., describing two portable oxy-acetylene welding and cutting outfits. The leaflet is called "Machinery Repairs," and contains several pertinent illustrations of the saving effected in repairing broken machinery by the oxy-acetylene process.

DYNAMIC BALANCE.—The Norton Grinding Company, Worcester, Mass., has issued "A Treatise on Dynamic Balance" which will be of interest to all who do not understand the difference between the standing and running balance of machine parts which revolve at a high speed. The need of a running balance and a special machine to test it is made evident.

TURRET LATHES AND TOOL GRINDERS.—Some interesting machine work that is being done economically on turret lathes is shown in a bulletin entitled "Increasing Production with Gisholt Machines," issued by the Gisholt Machine Company, Madison, Wis. The well known advantages of a good tool grinder are also explained and the arguments advanced in this booklet are exceptionally clear and convincing.

RIVET CUTTING.—A booklet called "Flexible Rivet Cutting Gun" (Book No. 2), is being circulated by the Rivet Cutting Gun Company, Cincinnati, Ohio. It shows how, by the use of the gun, much time can be saved in cutting rivets in boiler seams and in doing other railway repair work. The gun strikes a much harder blow than can be struck with a sledge, and it can be used in cramped and inaccessible places. In the back of the book is a list of parts and complete instructions for assembling and repairing.

BORING MILL CHUCKS.—The Commonwealth Supply Company, Richmond, Va., has issued a pamphlet called "The Moss Universal Chuck," which shows in detail how this chuck may be used on a vertical boring mill intended to handle railway shop work. It is particularly applicable to the boring of main rod brasses, driving boxes and piston valve bull rings. The chuck centers the work automatically both ways, which eliminates much of the laying out. Clamping is also unnecessary and the work may be turned over without removing it from the chuck, in case it is desired to face off both sides.

Railway Mechanical Engineer

Volume 92

May, 1918

No. 5

CONTENTS

EDITORIALS:

Doubling the Length of Runs.....	241
American Machine Tools in Australia.....	241
Freight Car Repair Problems.....	242
The Grinding of Car Wheels.....	242
Railroad Efficiency Depends on the Shops.....	242
Standard Locomotive Situation.....	243
Machine Tools Are Badly Needed.....	243
Keep the Cars in Good Condition.....	244

GENERAL:

In Memoriam—Joseph W. Taylor.....	245
Standardization of Locomotives.....	246
A Yankee's Idea of French Engines.....	249
Status of Standard Locomotives.....	251
100 Per Cent Goal in Railroad Liberty Loan Campaign.....	254
Census Statistics of Railroad Repair Shops.....	255
The Dynamic Argument Problem.....	257
Air Supply to the Locomotive Firebox.....	260
Responsibilities of Railroad Men.....	260

CAR DEPARTMENT:

Tabular Method for Calculating Moment of Inertia.....	261
Hopper Cars Built by E. J. & E.....	262
Should the Master Car Builder's Repair Card Be Abolished During the Period of the War.....	266
Standard Steel Sheathed Box Car.....	267
Freight Car and Tender Truck Bolsters.....	270

SHOP PRACTICE:

Terminal Handling of Locomotives.....	275
Locomotive Fire Kindler.....	276
A Difficult Cylinder Weld.....	277

Handle Chisel Guard.....	278
Locomotive Side Play.....	278
Pneumatic Bench Clamp.....	279
File Setting.....	280
Effect of Bushing the High Pressure Cylinder of an 8½-Inch Cross Compound Compressor.....	280
Front Deck Brace.....	281
Ball Bearing Crank Pin.....	281
Prolonging the Life of Cutters in Davis Boring Bars.....	282
Cutting Tool Lubrication.....	282
Bench Drill.....	283
Indiscriminate Use of the Injector Causes Boilers to Leak.....	284
Reaming Tapered Holes to Standard Sizes.....	285
Home Made Pipe Bender.....	285
"Don'ts" for Apprentices and Others.....	286
Lubricating Oil Density.....	286
Side Rod Straps.....	287

NEW DEVICES:

Power Hammer Attachment.....	288
Rod Lubrication.....	288
Treated Canvas Roofing for Steel Passenger Cars.....	289
Horizontal Bench Miller.....	289
Angle and Lead Testing Machine for Thread Gages.....	290
Wood Milling Machine.....	291

GENERAL NEWS:

Notes.....	292
Meetings and Conventions.....	293
Personal Mention.....	294
Supply Trade Notes.....	296
Catalogues.....	298

Doubling the Length of Runs

One of the large items of expense which the mechanical department controls is the cost of handling locomotives at terminals. Efforts are constantly being made to reduce this expense, and to shorten the time the locomotive is held out of service. It is interesting to note that during the past few years some roads have attempted to eliminate the handling of locomotives entirely at certain terminals by running the engines over two divisions. These efforts have been fairly successful. They have resulted in appreciable savings in fuel and labor and have reduced the number of locomotives required to handle the traffic.

As a rule locomotives, when they arrive at the end of a run, do not have any mechanical defects that necessitate sending them to the roundhouse. The main difficulties met in trying to operate on long runs are due to bad coal causing clinkers in the firebed, or honeycomb on the flues, or bad water causing foaming. In many cases these troubles can be largely counteracted. Under the conditions existing in summer it is easier to lengthen the engine districts than it is in winter. There are no doubt a great many places where engines can be doubled through, at least during the summer season, if some special attention is given to the matter of reducing the trouble due to bad fuel or water. It is by no means impractical to clean the fires, and if necessary blow out the flues during a stop, and when foaming causes trouble, frequent blowing off, together with the use of anti-foaming boiler compound, will usually eliminate the difficulty.

The savings effected on one road by doubling the lengths of runs are reported as being more than \$75,000 a year.

Since 1915 this road has been running locomotives over two divisions on 34 runs, which aggregate 8,594 miles. The number of terminal handlings is reduced by 34 daily, thus saving 12,410 handlings in the course of a year. In addition to the saving of fuel and labor, there is a saving in motive power. The mileage per day made by locomotives on the divisions affected has increased 15 per cent, and it has been found possible to reduce the number of locomotives on the runs by 13 per cent.

American Machine Tools in Australia

"Among the imports from the United States during the last few years, machinery constitutes the largest item, and in the writer's opinion this will continue to be the case, particularly if there is a continuance of the present policy by which the railway departments manufacture and erect their own rolling stock and similar requirements. It is believed that in this line competent application engineering will be necessary in Australia and New Zealand to develop and hold the business for American products, though as a rule the railway officials are inclined to admit the superiority of most of the American machine tools." This paragraph in its few lines states what is probably one of the most salient facts in all the 164 pages of the report just issued by the Bureau of Foreign and Domestic Commerce as a result of an extended investigation by Commercial Agent Frank Rhea on American markets for railway materials, equipment and supplies in Australia and New Zealand. Mr. Rhea's report will be read with particular interest by ma-

chine tool manufacturers, because he spent some five months in Australia and speaks with the authority of one who has had many years' experience in both the railway and railway supply fields. But they will also want to peruse its pages because of the insistence he places on what he calls "application engineering" or on the importance of having representatives who see to it that any machines they sell are the ones best fitted for the work to be done, and who follow up the sale to assure themselves that the machine tool is giving entire satisfaction once it is in the shop. But the wealth of material as to Australian railway characteristics, methods of purchasing, and our opportunities there as given in the report should prove of inestimable value to other railway supply manufacturers, also. Australia and New Zealand are going to prove among our best export markets for railway supplies after the war. Inasmuch as export trade is one of the big problems of the day, the question can fairly be asked—and it is favorably answered in the report:—If the machine tool builders can do it, why can't manufacturers of other railway supplies do it also?

Freight Car Repair Problems

With the formation of the Car Repair Section of the Railroad Administration, with J. J. Tatum, formerly of the Baltimore & Ohio as manager, the maintenance of freight cars has been brought under centralized control as has the maintenance of locomotives. There is much good to be realized by bringing under one head this vastly important problem. It is believed that judiciously proportioning bad order cars amongst the roads will greatly relieve the bad order car situation. There is one very important fact that must be impressed upon every man in the various repair organizations, and that is—*the cars when once placed on the repair tracks should be put in A No. 1 condition regardless of ownership before they are allowed to get back into service.* This means even more than is outlined in Rule 1 of the M. C. B. interchange rules. It means that a "lick and a promise" will not do.

We understand that consideration is being given to the discontinuance of interbilling between roads for such repairs, as under government control and the unification of the roads there is no necessity for such practice. If this can be done without in any way causing a lack of care in making the repairs, it would seem to be a good thing. It will undoubtedly make necessary increased supervision and more rigid inspection. The effect such a plan would have on the car situation a few months hence is very apparent, and there is no reason why it cannot be successfully carried out if everyone will pitch in and do his work properly *regardless of the initials stenciled on the car.*

Every car man in the country will do much to relieve the bad order situation if he will get in and get under, and back the manager of the car repair section up to the limit.

The Grinding of Car Wheels

The question of the advisability of grinding car wheels in order to remove flat spots and reclaim the wheels for further service is a particularly vital one at the present time because of the need for increased wheel mileage. One of our readers has been inquiring about this practice and for the benefit of all we invite expressions of opinion from any who have had practical experience along this line.

Car wheel grinding was first tried a number of years ago, and since that time several railroads have installed equipment and grinding machines with gratifying results. One large western road in particular has been successful in grinding chilled cast iron wheels for some time and claims a big saving. A test of the equipment was made and in an

itemized cost statement which included charges for interest, depreciation, power required, grinding wheels and labor, the total cost of reclaiming one pair of wheels by grinding was shown to be less than sixty cents. At the time of this test the differential per pair of wheels, or difference between the new and scrap values, was more than six dollars, and the resultant saving was evident. There was also an additional saving which was hard to estimate in the decreased wear and tear on equipment due to the removal of flat spots and wheel eccentricities.

A grinding machine has been developed recently for shaping the wheel flanges, but it has not been in use long enough to demonstrate its value. Practically all of the grinding up to date has been done on the tread of the wheel. No attempt has been made to grind out flat spots over $3\frac{1}{2}$ in. long, because in the case of chilled cast iron wheels it is not desirable materially to reduce the thickness of the chill.

New wheels often have a rough tread and are bored out and mounted eccentric with respect to the journal. This is almost sure to result in brake shoe gripping the wheel, causing slid flat spots before the wheels have made a thousand miles. In that case the scrap value of the wheel is saved, but half the new value is lost, plus the cost of machining, mounting on the axle, putting it under the car and taking it out again, to say nothing of the loss of service of the car in the meantime. We cannot afford such a wasteful practice in view of the present car shortage. The remedy for the above condition is to grind all cast iron car wheels before they are put into service as is the practice of one road.

But grinding is not entirely confined to cast iron car wheels. The same road previously referred to buys all of its Schoen steel wheels as they come from the rolls at three dollars less per wheel than if they were machined. The wheels are then bored, mounted and ground at a total saving of over \$5 per pair.

A consideration of the reports and data at hand indicates that car wheel grinding is a good thing and that the practice is being rapidly extended.

Railroad Efficiency Depends on the Shops

Anyone with roundhouse experience knows that there are certain locomotives that no engineer wants to run and no fireman wants to fire. Other engines are so popular with the roadmen that they will resort to all sorts of schemes in endeavoring to get them. Why is it that all locomotives of the same class do not give equally good performance on the road? The answer may be different in nearly every case but the general cause is probably minor variations in workmanship.

Some time ago one of a large number of locomotives was selected for a test. The roadmen declared the trial would be worthless because the engine was one which was called all the uncomplimentary names they could invent. When it was put on the road it surprised them by its splendid performance. The reason was that the shop men, when overhauling the locomotive prior to the test, discovered that the exhaust nozzle did not point to the exact center of the stack. They took unusual care to correct this defect with the result that the engine when turned out of the shop steamed freely and made a fine record.

Let us cite another instance to show the necessity for accuracy in shop work. A certain class of locomotives had very little clearance between the trailer wheel and the ashpan. Occasionally when a spring hanger broke the trailer tire would cut through the pan. The boiler maker foreman saw an easy way out of the difficulty and whenever he found the pan cut by the wheel, he raised it, placing it closer to the mudring. The result was that while the ashpan

was protected, the air inlet to the grates was reduced to such a point that proper combustion could not be secured.

No matter how well an engine steams, it cannot work economically unless the steam is distributed to the cylinders in the proper manner. Few railroad shops strive for extreme accuracy in the work of setting valves. A very slight variation in the dimensions of parts of the valve gear may result in an excessive consumption of steam and fuel. Since the railroads now spend more than \$4,000 annually for fuel for each locomotive they operate, and since poor valve setting may cause the fuel consumption to be 25 per cent greater than with the valves set properly, it can readily be seen that it is economical to spend a few dollars extra in the shops to do the work in the best manner possible and also to overhaul the valve motion in the roundhouse at frequent intervals with a view to keeping down the fuel consumption.

Most railroad shops have the apparatus required for properly balancing driving wheels, but in most places it is used only on rare occasions. A locomotive improperly counter-balanced is hard on the track and is uncomfortable to ride, to say nothing of the damage it does to its own machinery. An engineman can't be expected to take good care of a locomotive if the shop does not put it in condition to run without shaking him off the seat box and pounding out its own bearings.

The men who repair locomotives should bear in mind constantly the big part they play in securing efficient operation. Unless a locomotive is properly repaired it will waste fuel and thus add to the largest single item of expense the railroads bear. Unless it is an efficient and reliable machine, able to haul its tonnage over the division in a reasonable time without delays or engine failures, the transportation department cannot secure the maximum movement of traffic. A realization of the importance of the work in the shops should lead the men of the mechanical department to pay closer attention than they now do to those features of their work which are so essential to the economical operation of the railroad as a whole.

Standard Locomotive Situation While the locomotive standardization committee's work has progressed to the extent that tentative specifications have been issued, it cannot be found that the Railroad Administration has formulated any definite plans as to the extent to which the standard locomotives will be used. Impressions have gone abroad that the first orders for these locomotives will be sufficient to cover the demands for power that has been borrowed, thus permitting the borrowed locomotives to be returned to their home roads. Whether this plan is to be strictly followed remains to be seen. Unquestionably this would be the most practical limit to which standardization of locomotives should be carried.

As noted elsewhere in this issue, the tentative specifications were sent to the railroads with the request that the roads advise the director general of the number of standard locomotives they need to meet the requirements for this year. Following this, a memorandum was sent to various lines to the effect that if these standard locomotives did not meet the requirements, representation could be made as to the individual necessity for a departure from the standard types. This presents the matter in an indefinite sort of a way, and the interpretation to be made is open to question.

It is becoming rapidly apparent that unless something is done immediately, the output of locomotives for this year will not be up to maximum. In fact, G. A. Greenough said on April 15 before the Western Railway Club: "It is probable that the possibility of greater rapidity of construction has been lost for this year because of the length of time which the administration has required to give consideration

to the project (standard locomotives)." In its first report to Mr. McAdoo, dated February 19, the builders' committee stated that it would not be advisable to design standard locomotives without taking into consideration to the greatest possible degree the standards existing on the railroads at the present time and that "the proper execution of such a series of standard designs cannot be carried out in time to permit the building of any of these locomotives for 1918 delivery." The committee suggested further that if "this year's full capacity be utilized, the railways be permitted to order for quick delivery or until these standard designs can be worked out, such locomotives as they require, exact duplicates of those now in service on their lines." While it was realized that this condition would exist as far back as February, it is strange that no action has been taken to increase the output of locomotives this year. In our last month's issue we commented on the difficulties that would be experienced in maintaining standard locomotives in our already overtaxed shops. During the month Alba B. Johnson, president of the Baldwin Locomotive Works, in a paper before the United States Chamber of Commerce, which is printed elsewhere in this issue, took occasion to say: "Instead of simplifying the problem of locomotive maintenance, the introduction of government standards would complicate it." He also said: "The railroad manager who is responsible for his record of efficiency and economy should be permitted the widest discretion in selecting locomotives which he regards as best fitted for the conditions of service upon his line."

It is thus apparent that the builders as well as the railroad men realize the difficulties to be experienced with standard locomotives, and it is to be sincerely hoped that the Railroad Administration in making its final decision as to the extent to which standard locomotives will be used, will be governed by these arguments. But the fact remains that *whatever is finally deemed advisable by the Railroad Administration must be accepted by railway men the country over as the course it deems wise to pursue, and everyone must be a good soldier and make the most out of the situation, that this country may be victorious in the war.*

Machine Tools Are Badly Needed The machine tool equipment of the average railroad shop is inadequate and makes efficient production impossible. The Master Mechanics' Association has repeatedly brought out the fact that better tools are needed in shops and roundhouses. The roads have not been able to secure the equipment because their revenues were inadequate and they did not have the money to spend for machine tools. The condition has been growing worse instead of better. During the years immediately preceding the European war, the roads spent on an average \$12,000,000 annually for shop machinery and tools. In 1915 they spent only \$9,000,000. For the past two years there has been a great demand for machine tools for war work, the prices have increased greatly and as a result the roads have confined their purchases principally to tools that were urgently needed. It is safe to say that the expenditures for tools have been smaller during the past two years than they were in 1915, and as practically nothing has been done to improve the facilities the shops are probably no better off now than they were two years ago, if indeed they are not in even worse condition.

Some shop men feel that with prices so high, the purchases should be restricted and that no tools should be bought except those that they cannot get along without. On the contrary, there never was a time when money invested in machine tools would bring larger returns. There is a serious shortage of skilled mechanics and the roads are finding it increasingly difficult to repair their equipment. Modern machine tools will increase the output per man,

and tend to counteract the labor shortage. The roads are now paying mechanics higher wages than ever before. They should provide these men with tools that are capable of high rates of production, in order to get a corresponding return for the wages they pay. In fact, this is practically the only way in which the large increases in the wages of mechanics can be offset. In 1915 the total compensation paid by the railroads to mechanics, helpers and apprentices, was over \$90,000,000. For the present year it will probably be 40 per cent higher or about \$125,000,000. Suppose that by providing better machine tools, the output per man for this class of workers could be increased by two per cent. If interest and depreciation is figured at the rate of 12 per cent annually, this saving would justify the expenditure of more than \$20,000,000.

Better machine tool equipment effects an important saving by cutting down delays to locomotives and by increasing the available supply of power. This is especially important in the roundhouse. The ordinary roundhouse machine shop is equipped with tools that have been used in the back shop until worn out and they should have been sent to the scrap pile. This is an economic mistake. Minutes lost in doing machine work in the roundhouse may result in costly delays. Under present operating conditions the roundhouse is often the neck of the bottle, and everything possible should be done to expedite the work of making running repairs.

Contrary to the opinion that seems to prevail among railroad men, nearly all classes of tools can now be secured within a reasonable time after the orders are placed. The requirements of the war industries seem to have been met, and conditions are becoming more nearly normal. While some special machines, such as wheel lathes and large planers, cannot be secured without considerable delay, a few of the smaller tools can be delivered from stock and most of the shop equipment which railroads use can be had within six months from the date ordered. Tools ordered now will be available in time to help keep the equipment in condition next winter.

With an acute shortage of labor the shops and roundhouses were in many cases unable to meet the demands made upon them last winter. Those occurrences will be overlooked because the conditions could be foreseen. It is certain that next winter will again test the capacity of our transportation system. The mechanical department is responsible for the condition of the equipment. If it is to do its full share in keeping up the efficiency of the roads it must have better facilities. Now is the time to decide what tools will increase the output of the shop, and to put in orders to make up in part for the small purchases of the last three years.

Keep the Cars in Good Condition

"During 30 days there have been over 200 cases of truck failures on our road," said the head of the car department of one of the large trunk lines recently. Speaking further of the condition of cars at the present time, he said that it seemed as if some roads are not doing all they should do maintain the trucks in good condition while cars are on their lines. There were many cases of arch bar trucks failing on account of nuts missing from oil box and column bolts. Many brake hanger bolts were found without cotters, split keys or nuts to hold them in place; others were worn half through. Brake beams had no safety devices to hold them up in case the pins or hangers should break. The road referred to is now giving particular attention to the condition of these parts. No car is allowed to leave the repair track until the trucks have been thoroughly inspected and put in good condition.

The unusual amount of trouble that is being experienced

due to these minor defects, is an indication that there is a growing tendency on the part of inspectors to pass by the minor defects. This is because of the fact that there is a great demand for cars and all the roads are trying to keep the maximum number in service. The car shortage this year has broken last year's records. For the past 18 months the demand for cars has exceeded the supply. The hard service has been wearing the cars out faster than ever before, and it has been difficult to get them to the repair track. The roadbed has deteriorated causing an increase in the amount of work on trucks. As a result of these conditions, derailments and wrecks have been more numerous in the past winter than ever before.

It is hardly necessary to point out that the standard of inspection must be maintained, regardless of the demand for cars. The car inspector's work is vital to the safe operation of trains, and he should never lose sight of the responsibility that rests upon him. He must not pass by defects that may cause accidents, hoping that no harm will come of them. In spite of all precautions there will be occasional equipment failures. Even a slight defect, intentionally neglected, may cause serious damage or even loss of life.

Beyond doubt the car repair forces will have a difficult task trying to keep the equipment in good condition during the present year. Although the statistics show that the number of cars in shop or awaiting shop is no greater at this time, than for the corresponding period last year, there is no question that the general condition of equipment is constantly growing worse. Practically none of the roads has been able to keep a full force of car repairers because the higher wages paid in other lines of work has drawn the men away from the railroads. There seems to be little prospect that labor conditions will improve, although it may be that the Railroad Wage Commission will make adjustments in the rates of pay that will put the car department in a more favorable position. The material situation shows some improvement and there will probably be little difficulty in securing either wood or steel this year.

One of the conditions that will make it hard to keep up the output of the repair track is the increasing percentage of foreign cars on all lines. With the unrestricted routing of cars more and more will find their way off the home line, and since no improvement can be anticipated every road must arrange to give the same attention to all cars regardless of ownership and must attempt to keep up the normal output of the repair track, even though the men are working on equipment with which they are not familiar. The painting is being neglected. Unless this is attended to promptly the deterioration of cars is sure to be repaid. All roads should arrange to repaint foreign cars as well as their own, in order to forestall the depreciation of equipment. Every repair track should keep a full force employed and should arrange to put every car that passes over it in good shape regardless of the ownership.

There are some who advocate the suspension of the M. C. B. rules for the period of the war, on the grounds that it would expedite the movement of cars. This is a radical proposal, and it seems that those who make it have overlooked the fact that the principal function of the M. C. B. rules is to insure that safe practices are followed in the construction, repair and operation of cars. The interchange of repair cards may be done away with while the roads are under government control, but all regulations that make for safe operation should be retained. The car situation will not be improved by radical measures. The equipment can be kept up if the roads are given assistance in securing an adequate supply of labor and material and if everyone in the car department works with a patriotic spirit to serve not merely the railroads, but the country whose commerce they carry—the country whose interests we all have at heart.

IN MEMORIAM—JOSEPH W. TAYLOR

Secretary of the Railway Mechanical Associations
and the Western Railway Club Dies Very Suddenly

ONE of the most widely known and best liked men in railway mechanical circles has passed away. Joseph W. Taylor, for many years secretary of the American Railway Master Mechanics' Association, the Master Car Builders' Association and the Western Railway Club, died at his home, 4102 Calumet Avenue, Chicago, on the morning of April 24. Organic heart disease was responsible for Mr. Taylor's sudden death. He had been at his desk the day before he died, and was apparently in good health. Mr. Taylor was known to everyone who attended the meetings of the Master Car Builders and Master Mechanics' Associations, through his long connection with those organizations. Previous to the time when he took over the work as secretary, he acted as secretary to John W. Cloud, who formerly held those offices. Even before assuming the position which he occupied up to the time of his death, Mr. Taylor was a familiar figure at the conventions held at Saratoga and Old Point Comfort. As assistant to Mr. Cloud he took an active part in the preparation of proceedings of the Master Car Builders' and Master Mechanics' Associations. In 1899 Mr. Cloud went to London to take charge of the British office of the Westinghouse Air Brake Company and in June of that year Mr. Taylor was appointed secretary of both associations. His appointment as secretary of the Western Railway Club followed in October, 1899.

William Schlafge, president of the Master Mechanics' Association, says in commemoration of Mr. Taylor:

"The news of the death of Joseph W. Taylor will be received as a distinct shock to many friends and acquaintances throughout the country.

"During the twenty years of Mr. Taylor's services as secretary to the railroad mechanical associations his uniform and unflinching courtesy have won the very high regard and esteem of the many executive officers of the associations not only, but of the hundreds of members who have had occasion to seek his counsel in the routine of association activities.

"The sympathy of the entire railroad mechanical world will be extended Mr. Taylor's family in their bereavement which is particularly distressing in view of Mrs. Taylor's impaired state of health."

A. R. Kipp, president of the Western Railway Club, in a note of appreciation says: "The sudden death of Joseph W. Taylor was a great shock to me. Notice of it came to me at Minneapolis at the same hour in which I received a pencil note from him written the day before. Joe Taylor

will be missed by many men in railroad circles and nowhere will he be missed more than by members of the Western Railway Club who have seen him for so many years performing faithfully his duties as secretary at its meetings. Few railroad men there are who did not know him personally or at least by reputation through his position as secretary of the various mechanical organizations. It is characteristic of his faithfulness that he died in the harness."

Joseph W. Taylor was born in Saltsburg, Pa., on March 9, 1862. He entered railway service early in life on the

Erie railroad and was for a time a locomotive fireman.

Later he became associated with the Westinghouse Air Brake Company at Chicago, but gave up his position to devote his entire time to his duties as secretary of the M. M. and M. C. B. associations. For the last 19 years Mr. Taylor has been secretary of these associations and also of the Western Railway club. During the entire time he has taken a prominent part in the work of these organizations. Throughout his long tenure of these offices, Mr. Taylor discharged his duties in a thorough, efficient and most trustworthy manner. He never betrayed the confidence of his position. The reports and proceedings which he edited were always models of correctness. As Mr. Taylor has had no assistant in the work, it will be a difficult matter to find a man to fill his place.

At the 1910 conventions a tribute was paid to Mr. Taylor through the columns of

the Railway Age Gazette which so clearly shows how much he was appreciated that it is reprinted here:

"When John W. Cloud—known as the 'ideal' secretary of the Master Car Builders' Association for many years and of the Master Mechanics' Association for a shorter period—in 1899, resigned to accept the representation of the Westinghouse Air Brake Company in London, many doubts were expressed as to the possibility on the part of either or both associations of finding a successor whose work would be even a passable substitute for that to which they were accustomed. Wisely, however, as it appeared then and as it has appeared with double force every year since, it was determined that the safest course lay in the selection of one who had had the benefit of Mr. Cloud's training and who, in fact, had done the principal part of the detail office work as Mr. Cloud's assistant. Notwithstanding that the duties of the office have very largely increased by reason of the increased membership and volume of work done by both associations—a fact only partially shown by the growth



Joseph W. Taylor

in size of the volumes of proceedings—Joe, as he is almost universally called, has never found the job too big, nor has he failed to come to time when any ordinary or extraordinary demand has been made upon him. Unquestionably and by right of faithful and intelligent work the mantle of the 'ideal' secretary now rests upon Mr. Taylor's shoulders.

With few exceptions probably the members of neither association appreciate the volume of work which the secretary is called upon to perform between one year's convention and the next. It is an ever-continuing job, though the culmination of its activities is naturally in the period a few months before and a few months after the conventions. The office is the focus of all the movements of both associations. It is the medium through which hastily prepared and sometimes ill-digested plans of a few members are filtered before they come to the attention of the associations as a whole or to the public. The secretary is not only the recorder, accountant and editor; he is in a most unobtrusive and unrecognized way a 'whipper-in' and adviser to all the members, the effectiveness of this persuasion and the acceptability of this advice consisting precisely in this unobtrusiveness and lack of recognition.

"Joe Taylor has been secretary of these two associations and of the Western Railway Club so long that it is hardly worth while to recall what he was before, except as Mr.

Cloud's assistant. He is generally credited with having held down a chief clerkship on the Erie before he went to Chicago; but it doesn't matter. He has made himself and he has made the secretaryship of three important railway organizations—all of them jobs worth bragging about. But 'Joe' never does that and that is why his newspaper friends have to step in—like this."

Mr. Taylor's personal characteristics endeared him to his large circle of acquaintances. Straightforward and open in his manner, sympathetic and always ready to lend assistance, he went about it in a quiet way aiding many without the knowledge even of his intimate friends. He was intensely patriotic and had taken active interest in the Liberty Loan campaigns. Mr. Taylor took a prominent part in the work of fraternal organizations and was a 32nd Degree Mason.

His funeral was held at Chicago on Saturday under the auspices of the Knights Templar. Representatives of the Master Car Builders' Association and Master Mechanics' Association and the Western Railway Club were present, as well as many of Mr. Taylor's personal friends and associates. Mr. Taylor is survived by a brother; a son, Joseph W. Taylor, Jr., of El Paso, Texas, and his widow who is in very delicate health and on that account has resided in Texas with her son for several years past.

STANDARDIZATION OF LOCOMOTIVES

Its Possible Effects on Transportation Discussed
by Two Officers of the Baldwin Locomotive Works

THE effects of the application of a policy of general standardization of locomotives to American railways was discussed by Alba B. Johnson, president of the Baldwin Locomotive Works in a paper on the Railroad Administration's Motive Power Problems, which was presented on April 11, before the United States Chamber of Commerce at the annual meeting held in Chicago. At the meeting of the Western Railway Club, held in Chicago on April 15, Grafton Greenough, vice-president of the Baldwin Locomotive Works, also took occasion to discuss the same subject in a paper on Economy in Maintenance and Operation of Locomotives.

ALBA B. JOHNSON'S PAPER

Mr. Johnson's paper briefly sketched the history of the development of the locomotive, from the time of the Rainhill trials on the Liverpool & Manchester, in 1829, which demonstrated the practicability of Stephenson's "Rocket," showing the rapid strides in growth and development which have taken place in the intervening 89 years. An abstract of the portion of the paper dealing with standardization follows:

Standardization has been an ideal much talked of but never realized in actual practice, because standardization implies the crystallization of present practice as the practice of the future, and means that no further changes shall be made as the result of experience or invention. Carried to its logical extreme, the adoption of inflexible standards at any time during the history of locomotive development would have involved the stoppage of progress at that point. Many attempts have been made to fix standards for particular railroads and groups of roads, but in every instance these have given way to the urgency of keeping pace with other roads which have not attempted to bind themselves with the iron bands of standardization. The practical result of such attempts has been that those lines most

rigidly adhering to their standards have lagged behind their competitors.

The result of more than eighty years of experience has convinced railroad men that the most advantageous field for standardization is in details rather than in the complete locomotive or car as a unit. Most of the advantages sought through standardization have been obtained by unifying or standardizing the design of various parts common to a considerable number of classes. Whilst the American Railway Master Mechanics' Association and the Master Car Builders' Association have perhaps accomplished less in procuring the adoption of complete standard units than advocates of standardization would have liked to see, they have done splendid service to the transportation interests of the country by the adoption of the numerous standard details, by their discussions and by their interchange of experiences. It may be said that their accomplishments have been as great as it was humanly possible to achieve under the conditions of diversity of managements, diversity of ideas and the necessity of constantly keeping abreast of the march of improvement. American railroad men need have no fear of comparison with other countries, either in the practical common sense which has been shown in the conservative encouragement given to improvements in engineering practice, or in the reductions which have been achieved in the cost of transportation.

WAR BRINGS NEW CONDITIONS

The participation of the United States in the world-war has brought about new conditions. For the first time it became practicable to adopt and to enforce standards to a large extent. The very forces of competition had brought about a uniformity of general dimensions and weights of locomotives for trunk line service. Inasmuch as all kinds of cars were being hauled indiscriminately over all railroad lines, there could be no reason why a diversity of details

should exist amongst those belonging to different railroads. To a lesser degree, perhaps, these considerations apply also to motive power. If one type of locomotive could haul a given train across the continent to the west bank of the Mississippi river, there appeared to be no adequate reason why a locomotive of different type or different details should be required to haul the same train from the east bank where the grades and working conditions were not too divergent.

In the early days of railroading it was quite common for the same line to have different types of locomotives to haul its trains over different divisions of the road. The same conditions now exist upon a larger scale. Notwithstanding a certain amount of standardization of the locomotives on each road, there is a large diversity amongst different roads having practically the same operating conditions. The opportunity given to the director general of railways to unify the motive power of all railroads, was unique, and the conception a fascinating one. The work of preparing standard specifications and drawings was entrusted to a committee comprising eleven railroad officials who collaborated with representatives of the three principal locomotive builders. As the result of their diligent and continued work, twelve standard specifications have been agreed upon and their final approval is at the present time under consideration.

No one railroad will be compelled to order all of these 12 standards; even the largest trunk lines may find half that number sufficient.

EXTENT TO WHICH STANDARDIZATION SHOULD BE CARRIED

A delicate and interesting question of policy is to what extent these standards should be confined to the essential elements of the locomotive, and to what extent they should be confined to its accessories. The committee wisely adopted the principle of defining only the essential locomotive, leaving a certain freedom to the railroads to maintain their standard accessories, and a certain freedom of competition among manufacturers of railway equipment. It must be borne in mind that the railway equipment business itself is a most important one, embodying as it does several hundred separate manufacturers, with invested capital running into the hundreds of millions and employing several hundred thousand men. These separate manufacturers have studied incessantly to improve their appliances and to reduce their costs.

Their productions are of two classes, first, those materials or devices which have become essential parts of locomotives, such as air brakes, tires, headlights, injectors, steam gages, etc., etc.; and second, those which are not strictly essential to locomotive operation but which contribute to efficiency and economy. Amongst the latter are such things as mechanical stokers, superheaters, feed water heaters, power reverse gears, etc. These devices are constantly shifting from the second to the first class. Most of those now universally conceded to be in the first class were at one time probationary. Many of those now rated in the second class are rapidly achieving recognition as essentials to be regarded as in the first class. To carry standardization to its extreme limit would involve a determination of the most desirable among many competing devices, and would destroy the market for all the others and throw their makers out of business. It would check the transfer into the first class of those items enumerated as of the second class and would also paralyze every effort toward the invention and introduction of new improvements.

The committee has wisely refrained from attempting a solution of these problems, and its further course with respect to them is yet to be ascertained. Some policy must eventually be adopted, however, either of leaving the railroads which are to receive and operate the standard loco-

motives, latitude to designate such specialties as in their experience have proved worthy of adoption, or for the director general of railways, through his advisers, to make a selection. The former would appear to be in every way the wiser course.

THE USE OF STANDARD LOCOMOTIVES WILL COMPLICATE REPAIR PROBLEMS

I have stated above that the standard specifications have been recommended for approval. They have not yet been finally adopted, as a strong plea is made on behalf of the railroads similar in principle to that applicable to locomotive accessories, that each railroad should be allowed to continue to adhere to the standards already adopted. The choice of course involves the weighing of the respective advantages. It may be said for the railroads' contention, that under normal conditions locomotives are not shifted from one road to another, but are generally used continuously upon the same division to keep the traffic movement balanced, and are kept in repair continuously by the same shops. These shops are supplied with standard repair parts and the workmen are proficient in maintaining the repairs of these existing standard locomotives. To introduce a new government standard upon all lines as an entirely clean proposition would be simple enough, but to introduce it on lines and conditions affecting an entire continent and already equipped is quite a different problem. It necessarily compels all lines to provide themselves with stores of repair parts adapted to the government standard locomotives. Thus, instead of simplifying the problem of locomotive maintenance, the introduction of government standards would complicate it. These complications would last far beyond the period of government control and would continue as long as the railroad standard and the government standard locomotives operated side by side upon the same lines.

LET RAILROAD MANAGERS CHOOSE LOCOMOTIVES BEST SUITED TO THEIR CONDITIONS

It may be said that the workman who is responsible for the best workmanship, should be entitled to the selection of his own tools, and similarly, that the railroad manager who is responsible for his record of efficiency and economy, should be permitted the widest discretion in selecting locomotives which he regards as best fitted for the conditions of service upon his line. If, however, it should be urged that the advantages of standardization to which the roads can work, would in the long run be sufficient to compensate for the disadvantages of present increased confusion, then some principle must be discovered by which standardization shall avoid the cessation, if not the extinction of improvements. Every improvement in some sense involves the destruction of standardization. It would be an evil day for American engineering and for American progress in the art of transportation, which would involve a policy of discouragement to new and useful improvements in the art. We should therefore look carefully before we leap, to make sure that we are not giving up the substance of continued growth in efficiency and economy, to grasp the chimera of standardization. Especially should this be considered most carefully when the world-wide danger of this war is upon us.

MONEY FOR IMPROVEMENTS RESTRICTED

The motive power of the country is admittedly inadequate to the service demanded of it under the present war conditions. During the depression preceding the war there was a small surplus of power which, as should have been foreseen, would be absorbed in traffic with the first increase of activity. As a rule, railroads have purchased locomotives largely under the spur of excessive traffic and have ab-

stained from purchasing during periods of reduced earnings. This is contrary to the economics of the situation. Enlargements of facilities should be made in times of depression, because, first, that is the cheapest time to do it; second, it is the most convenient time to do it; and third, it is the time when the managers can give most attention to doing it and fourth, the employment of labor arising out of large railway purchases tends to mitigate the severity of a general depression. The reason the railroads have not done this since 1907 is, that under the regulatory policy which went into effect at that time, railway managers have not been able to accumulate surpluses sufficient in their judgment to warrant bold construction in times of small earnings, and especially because future earnings have not been susceptible of approximate calculation even where the volume of traffic could be estimated in advance. Adequate provision of motive power, like adequate provision of other rolling-stock and other facilities, can only be assured when Congress places upon the functionary charged with the duty of regulating rates, the definite responsibility of making such rates as will yield earnings sufficient for thorough maintenance, for adequate improvements and sufficient to attract the capital necessary for providing additions and extensions.

GRAFTON GREENOUGH ON STANDARDIZATION

In his paper read before the Western Railway Club, on April 15, Mr. Greenough discussed the locomotive standardization problem as follows:

The recent change in the controlling power of railroads has brought about the possibility of experimenting along lines which have long been under contemplation, but have been deemed outside the realms of the possible. I refer to the proposed standardization of the locomotive as a unit. The railroad administration, primarily to reduce the first cost of locomotives and with a view to effecting an interchangeability in repair parts which would enable locomotives to be transferred conveniently from one section of the country where transportation might reach a low ebb to another more congested district, has through conferences with the builders and the railroad committee proposed to bring about a series of standard locomotives. The committees appointed have done their work efficiently and there are under consideration twelve designs of locomotives, in some cases two of a single class, one heavy and one light.

The arguments in favor of such standardization are interchangeability between railroads, the possibility of some rapidity of construction, interchangeability of repairs and a somewhat lower cost. It is probable that the possibility of greater rapidity of construction has been lost for this year, because of the length of time which the administration has required to give consideration to the project. We could doubtless have built a larger number of locomotives, exact duplicates of those now on the railroads, had orders been placed two months ago, in a shorter time than we will be able to build the new types of locomotives, details concerning which are not yet settled.

The arguments against standardization may be summed up as follows: The capacities of the locomotives are based upon average conditions; hence there is no provision for the extreme requirements which these locomotives do not cover. Where even the light locomotives are too heavy for service and where the heavy locomotives are not of sufficient capacity special locomotives will have to be provided unless those requiring lighter engines purchase from other roads discarded power, and those requiring the heavier locomotives change their system of operation so as to use the heavy standard government locomotive. In such instances where railroads have been equipped from one end to the other to use power of maximum capacity for the purpose of reducing train movements this would prove a negative economy.

The standard locomotives are designed for bituminous

coal fuel and radical changes in their construction will be required for burning anthracite or an appreciable percentage of anthracite or for properly burning pulverized fuel. Oil fortunately requires no basic change. The limiting sizes of the locomotives of length, height and width must necessarily conform to the minimum to be found on the various roads over which the locomotives are designed to operate. These restrictions necessarily cramp the designs and limit their efficiency to the restrictions of the fuel. A limit of height of 15 feet has been proposed for all except the heavy Santa Fe and consolidation Mallet type locomotives; consequently steam space, domes and smoke stacks are mere shadows of what they would naturally be. In a country as large as ours various physical and climatic conditions exist which the proposed standardization ignores; consequently the locomotives will afford maximum efficiency in some localities with a corresponding loss in others.

No standardization of this extent has been dreamed of in the past; hence the task is relatively momentous. The Pennsylvania has for years given serious consideration and effort to the standardization of their equipment; likewise the Harriman Lines in 1905 proposed a series of standard locomotives for all roads controlled by them. Both of these efforts have resulted in an extensive standardization of parts, but not in a complete standardization of equipment, because growing needs for larger and more efficient power and the improvements in the permanent way have invited and made possible increases in the size and capacity of locomotives which have thrown to the winds any idea of standardization of locomotives which would extend over an appreciable period of time. In both instances the standard locomotives of today bear no comparison to the standard locomotives of ten years ago. The conservation of our resources will not permit of a system of standardization which is so inflexible as to choke further improvements and thus discourage the inventions which may now be in their incipency. Yet how can we maintain a standard which is permitted to change, and how can we progress without change. If standardization of locomotives as units is a war measure; if it will help us win, let us have standardization quickly and regard it as a war measure but if it is an economic experiment the final net result may be the addition of just so many classes of locomotives to those now existing.

The ideal standardization provides for the elimination of unnecessary diversity and progress invites and necessitates diversity, hence in spite of our ideals the standardization of locomotives may be limited to the standardization of the maximum number of parts.

The problem now before the administration is to decide whether or not the criticisms in favor outweigh those against the proposed standardization, and we all await the decision with the keenest interest, and we all hope the decision, whatever it may be, will prove for the best.

MORE DESTROYERS THAN THERE ARE NOW IN THE WORLD.—E. G. Grace, president of the Bethlehem Steel Corporation, told the 500 guests of the Allentown, Pa., Chamber of Commerce at its banquet on December 20, that the submarine destroyers which the Bethlehem Shipbuilding Corporation will build for the government are more than all of the destroyers now in the world. Mr. Grace said he regarded the rapid construction of destroyers as the solution of the submarine menace. Mr. Grace said that of the entire ship construction of the United States, war vessels and merchantmen included, the companies of the Bethlehem Steel Corporation are bearing more than half of the burden. The Bethlehem plants now employ 30,000 men as compared with 9,000 five years ago. Charles M. Schwab, who also spoke, said that the payroll of the Bethlehem plants is now \$100,000,000 a year.—*Iron Age*.

A YANKEE'S IDEA OF FRENCH ENGINES

Letters from a Santa Fe Boy Describing the Motive Power and the Troubles Experienced in Maintaining It

THE censorship of correspondence has made it difficult to get news from the American Railway Regiments, nevertheless many interesting letters have been received telling of the work that is being done. The letters below and the illustrations accompanying them were sent by a member of one of the shop regiments, Sergeant G. T. Foster of Company F, Thirteenth Engineers, and are published through the courtesy of the Santa Fe Magazine. Referring to the French locomotives, Sergeant Foster writes:

"The photograph of engine No. 3544 shows a typical French locomotive used in passenger service. The cab is peculiar, affording poor protection in severe weather. It has no sliding windows or deck curtain, and is built with front doors and also the front cab wall diagonal, to break the wind at high speed. The cab door is an excellent idea, aside from the wind-breaking feature, because it gives more room for an average sized engineer to pass from the cab to the running board. The cab floor also projects a few inches outside the cab so that a large sized engineer can easily pass

dome, in which case it takes an entire book to describe it. More often it is located in the small box ahead of the sand dome, running clear through it with a gland and stuffing box on the front and back sides of this box.

"In this locomotive the throttle valve is inside the steam dome, with one stuffing box in front of the small box and another out on the rear of the throttle dome. The main dome and small throttle box are integral in this case, and the movement of the throttle rod is not a pull in a horizontal direction, as in the States, but is a twisting movement similar to opening and closing a globe valve. The throttle valve moves across its seat similar to the movement of the valve in the old Johnson blow-off cocks, only in this case the throttle valve is much larger than a blow-off valve and rectangular in shape, moving over a ported seat.

"The smokestack has a lid which is used when the engines are standing, to protect the flues. The headlight burns oil and is very small. Below the running board you can see the high-pressure cylinders and D-slide valve chest. You can

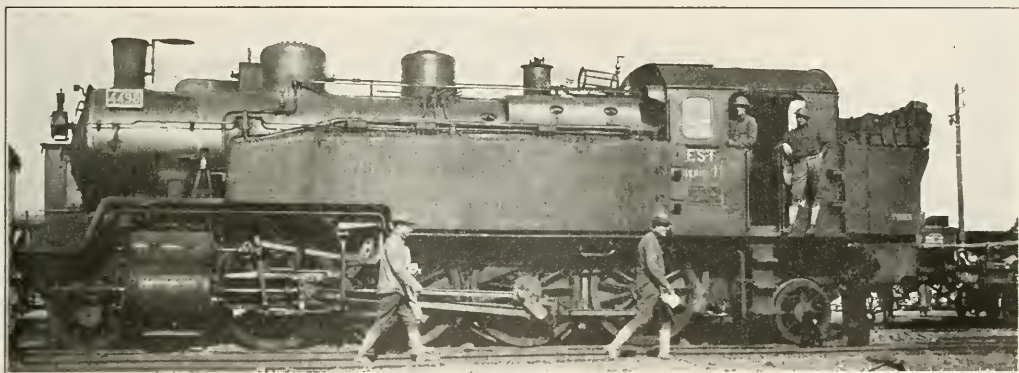

American Boys Railroading in France

from the gangway to the running board without entering the cab.

"About the roof of the cab can be seen the levers of the pop valves. The firebox, of course, is of the Belpaire type, with copper sidesheets and staybolts. Along the side of the boiler can be seen the air pump, which is simple on the steam end and tandem compound on the air end. About the only United States air equipment on this engine is a Westinghouse pump governor.

"Along the side of the firebox and also along the barrel of the boiler can be seen three rectangular oil boxes, from which oil pipes run down to the driving boxes, so that the engineer can oil the shoes, wedges and cellars while he is up on the running board. This is an excellent idea. The sandbox is immediately ahead of the firebox on the boiler. Air sanders are used. No special mention need be made of this feature excepting that the steps up to the sand dome are very convenient and safe. The auxiliary steam dome is inside the cab. The main dome is immediately ahead of the sand dome, with the throttle rod passing through it and into the small rectangular box immediately ahead of the main dome. The throttle valve is sometimes located inside the main

also see the piston rod extension and the Walschaert valve gear to the high-pressure cylinders. The steam pipes run outside the boiler from the throttle box to the high-pressure cylinder. The boiler check is just ahead of the steam pipes and is very small. Over the engine truck you can see one of the main reservoirs bolted to the running board. The main frames, as well as the tender and engine truck frames, are of heavy steel plate construction. The engine truck is equipped with air brakes.

"The tank shows the briquettes of coal piled on top. At the front of the tank and about a foot back of the gangway can be seen three plug valves, or cocks, which indicate the height of water in the tank. This is a very handy thing for the engineer. Above the top of the throttle box can be seen an oiler for pouring oil in a cup and feeding direct to the cylinders in case the lubricator goes to the had. They get very poor valve oil over here, and the lubricator and tallow pipes are easily stopped up. Their superheater valve oil, however, is excellent and does not give this trouble.

"The other photograph, of engine No. 4498, shows a saddle tank locomotive of very good design. The coal tank, with the usual briquette coal, is shown plainly at the back

of the cab, which is a good stormproof cab compared with most French cabs. The water tanks are carried along the running boards, so one does not have to worry about the federal boiler inspectors finding broken staybolts. The wash-out plugs over here are really hand-hole plates like those used in stationary practice in the States. Two of these are shown at the radius of the Belpaire wrapper sheet. Just ahead of the cab, on top of the boiler, can be seen a tank strainer which looks like a minnow bucket. The water goes through this strainer when the engine takes water at the water crane.

"Just ahead of the water tank along the running board can be seen a ratchet jack of about twenty tons capacity. All engines carry one of these. They are traverse jacks, the idea being to use four of these when an engine is derailed, under the four bearing corners of the locomotive. The engine is elevated and then traversed back to correct alinement and lowered to the rails. After rerailling several locomotives one would trade all his worldly goods for some good old American frogs.

"This engine has a Mikado wheel arrangement, simple cylinders, piston valves, extension piston rods and a superheater. The blower valve is on the outside of the main dome, with a valve stem running clear back to the cab. The

it's hard to run an engine in the rain, especially with poor headlights. Of course, putting in cylinder packing and reducing rod brasses is no joke either, out in the rain and snow. Some of our engines are very awkward to work on. When we have to use rope asbestos to pack steam leaks on engines and when we have to kill the engine to pack almost every valve, it's no joke. Then the valves are hard to grind in. Most of the valves, such as gage cocks, water glass valves, and water glass drain valves, are built in two pieces and do not have a removable bonnet. When the packing nut is removed the bonnet comes with it, so that it's almost impossible to grind in the valve and seat. We have to dress off the valve with a file and dress the seat with a dummy valve. We pack piston rods and valve stems with rope asbestos, so you can guess what luck we have keeping down steam leaks. We have to fight like everything to keep them down.

"Recently we secured some small copper wire, about No. 10 size, and we are using it to make copper gaskets for the small steam joints. These engines have no fountain, and every pipe comes from the boiler direct with a flange joint, and an asbestos gasket, at the boiler. So we have troubles of our own. Most of the piping is copper, with brazed joints. Injector branch pipes are made this way. When we get a bad leak we can't go to the storehouse and get a Cranc fit-



French Motive Power with an American Crew

rod operating the variable exhaust nozzle runs along the side of the boiler through brackets similar to hand-hole brackets, and is used as a handrail. One can easily see the throttle rod running from the cab through the auxiliary dome, sand dome, main dome and throttle box with stuffing boxes on the back of the main dome and front of the throttle box.

"The cab has no front door. One passes outside of the cab forward, using the handholds and steps shown along the sides of the cab in order to go forward over the water tanks."

The effect of inadequate facilities coupled with severe weather has evidently been felt in France as well as America during the past winter. In another letter Sergeant Foster writes:

"This letter is to all my friends, who were so generous in sending me a splendid big box of good old American tobacco. Words cannot express my thanks.

"I am working in an assortment of men from six different American roads. The men from these six companies work in two different towns. Just imagine working in a place like Cushing, Okla., with all the cold weather of Michigan and all the rains of Seattle, and very heavy business.

"Our coal chute consists of a string of cars, and the men have to throw the coal from the cars into the tenders. Some of the cabs do not give much protection from the rain, and

ting, but we hunt up the coppersmith, and usually kill the engine and then braze the pipe.

"Flues don't give us much trouble because we have no laws against flue plugs, and we have plenty of plugs. The copper fireboxes don't give much trouble either. Most of the firebox leaks take up when the engine gets out on the road. The front ends are not self-cleaning, so we have to watch them closely and keep the flues bored out daily.

"Our tools are very poor. We have monkey wrenches that you can work, provided you have a nut out in the prairie without anything around it. The hammers are heavy, and are splendid for an apprentice because they have faces as big as young sledges. The fireboxes are all narrow and most of them are very small. Most of them do not have any rocking and dump grates, so the fire cleaners have to shovel the old fire out of the firedoors. Believe me, it's lovely."

FREIGHT CARS TAKE WOUNDED TO GERMANY.—Trains carrying wounded Germans from the battle front in France are proceeding continuously between Germany and Holland, according to a despatch to the *Telegraf* from Kerkraede. It has been necessary to replace hospital cars by freight cars, in which the wounded lie on straw and shavings.

STATUS OF STANDARD LOCOMOTIVES

Probable Extent to Which They Will Be Used;
Tentative General Dimensions of Proposed Types

WHILE the details of the designs of the standard locomotives for the United States government have not been completed, a tentative specification has been drawn up giving the general dimensions of the 12 locomotives proposed. These have been sent to the railway companies with a request for the number of each design each road will need to meet its requirements for new locomotives this year. The roads were cautioned to check the limiting dimensions carefully and to allow for axle loads slightly heavier than those shown, as an added precaution, for it

operate locomotives of the wheel loads of the standard locomotives would be filled with locomotives of lighter axle load, which would be released by the standard locomotives.

Since these specifications were sent out a number of conferences have been held at the headquarters of the Railroad Administration in Washington on the subject of standardization, at which the matter has been discussed by C. R. Gray, director of the division of transportation, Henry Walters, who has been in general charge of the proposed standardization program for the director general, S. M. Vauclain

GENERAL DIMENSIONS OF THE MIKADO, SANTA FE AND MALLETT STANDARD LOCOMOTIVES FOR THE RAILROAD ADMINISTRATION

Type	Mikado	Mikado	2-10-2	2-10-2	2-8-2
Axle load	53,000 lb.	60,000 lb.	55,000 lb.	60,000 lb.	60,000 lb.
Specification Number	1-A	2-A	7	8	11
Gauge	4 ft. 8½ in.	4 ft. 8½ in.	4 ft. 8½ in.	4 ft. 8½ in.	4 ft. 8½ in.
Service	Freight	Freight	Freight	Freight	Freight
Fuel	Bit. Coal	Bit. Coal	Bit. Coal	Bit. Coal	Bit. Coal
Tractive effort	54,600 lb.	60,000 lb.	69,400 lb.	74,000 lb.	80,300 lb.
Weight in working order	290,000 lb.	325,000 lb.	360,000 lb.	390,000 lb.	440,000 lb.
Weight on drivers	220,000 lb.	240,000 lb.	275,000 lb.	300,000 lb.	360,000 lb.
Weight on leading truck	23,000 lb.	27,000 lb.	30,000 lb.	30,000 lb.	27,000 lb.
Weight on trailing truck	47,000 lb.	58,000 lb.	55,000 lb.	60,000 lb.	53,000 lb.
Weight of engine and tender in working order	466,000 lb.	497,000 lb.	532,000 lb.	596,000 lb.	646,000 lb.
Wheel base, driving	16 ft. 9 in.	16 ft. 9 in.	21 ft.	22 ft. 4 in.	33 ft. 2 in.
Wheel base, rigid	36 ft. 1 in.	31 ft. 1 in.	40 ft. 4 in.	42 ft. 2 in.	50 ft. 2 in.
Wheel base, total	71 ft. 5½ in.	71 ft. 9½ in.	76 ft. ½ in.	82 ft. 10½ in.	88 ft. 10 in.
Wheel base, engine and tender	71 ft. 5½ in.	71 ft. 9½ in.	76 ft. ½ in.	82 ft. 10½ in.	88 ft. 10 in.
<i>Ratios</i>					
Weight on drivers ÷ tractive effort	4.0	4.0	4.0	4.1	4.5
Total weight × tractive effort	5.3	5.4	5.2	5.3	5.5
Tractive effort × diam. drivers ÷ equivalent heating surface*	730.9	653.2	629.6	665.9	623.1
Equivalent heating surface* ÷ grate area	70.6	81.7	82.5	79.4	96.3
Firebox heating surface ÷ equivalent heating surface, per cent.	6.1	5.5	5.9	6.1	5.8
Weight on drivers ÷ equiv. heating surface*	46.8	43.3	42.9	43.0	49.0
Total weight ÷ equivalent heating surface*	61.6	56.2	57.3	56.2	59.9
Volume both cylinders	18.4 cu. ft.	21.2 cu. ft.	21.2 cu. ft.	26.4 cu. ft.	21.9 cu. ft.
Equivalent heating surface* ÷ vol. cylinders	255.3	272.9	296.3	265.2	336.1
Grate area ÷ vol. cylinders	3.6	3.3	3.6	3.3	3.5
<i>Cylinders</i>					
Kind	Simple	Simple	Simple	Simple	Compound
Diameter and stroke	26 in. by 30 in.	27 in. by 32 in.	27 in. by 32 in.	30 in. by 32 in.	23 in. & 35 in. by 32 in.
<i>Valves</i>					
Kind	Piston	Piston	Piston	Piston	Piston
Diameter	14 in.	14 in.	14 in.	14 in.	14 in.
<i>Wheels</i>					
Driving, diameter over tires	63 in.	63 in.	57 in.	63 in.	57 in.
<i>Boiler</i>					
Style	Con. Wag. Top	Con. Wag. Top	Con. Wag. Top	Con. Wag. Top	Straight Top
Working pressure	200 lb. per sq. in.	190 lb.	200 lb.	190 lb.	225 lb.
Outside diameter of first ring	78 in.	86 in.	86 in.	88 in.	90 in.
Firebox, length and width	114½ in. by 84½ in.	120½ in. by 84½ in.	114½ in. by 96½ in.	132½ in. by 96½ in.	114½ in. by 96½ in.
Tubes, number and outside diameter	216—2½ in.	247—2½ in.	247—2½ in.	271—2½ in.	247—2½ in.
Flues, number and outside diameter	40—5½ in.	45—5½ in.	45—5½ in.	50—5½ in.	45—5½ in.
Tubes and flues, length	19 ft.	19 ft.	20 ft. 6 in.	20 ft. 6 in.	24 ft.
Heating surface, tubes	2,407 sq. ft.	2,752 sq. ft.	2,970 sq. ft.	3,258 sq. ft.	3,478 sq. ft.
Heating surface, flues	1,090 sq. ft.	1,226 sq. ft.	1,323 sq. ft.	1,469 sq. ft.	1,825 sq. ft.
Heating surface, firebox	280 sq. ft.	319 sq. ft.	373 sq. ft.	429 sq. ft.	439 sq. ft.
Heating surface, total	3,783 sq. ft.	4,297 sq. ft.	4,666 sq. ft.	5,156 sq. ft.	5,742 sq. ft.
Superheater heating surface	882 sq. ft.	993 sq. ft.	1,078 sq. ft.	1,230 sq. ft.	1,260 sq. ft.
Equivalent heating surface*	4,706 sq. ft.	5,783 sq. ft.	6,283 sq. ft.	7,001 sq. ft.	8,420 sq. ft.
Grate area	66.7 sq. ft.	70.8 sq. ft.	76.3 sq. ft.	88.2 sq. ft.	76.3 sq. ft.
<i>Tender</i>					
Tank	Wat. Bot.	Wat. Bot.	Wat. Bot.	Wat. Bot.	Wat. Bot.
Weight	172,000 lb.	172,000 lb.	172,000 lb.	206,000 lb.	206,000 lb.
Water capacity	10,000 gal.	10,000 gal.	10,000 gal.	12,000 gal.	12,000 gal.
Coal capacity	16 tons	16 tons	16 tons	16 tons	16 tons

*Equivalent heating surface = total evaporative heating surface + 1.5 times the superheating surface.

may be possible that after the locomotives are built the axle loads will be higher than those shown in the tentative specifications.

The circular accompanying the specifications included a statement to the effect that special designs for extreme grades or other operating features which require heavier locomotives than those included in the specifications were too few and extreme to require standardizing. It was also stated that requirements for locomotives for roads which could not

and the regional directors. As a result of these conferences the uncertainty as to the scope of the standardization plan has in a measure been cleared up by a memorandum which has been sent out to the managements of the various railroads, the text of which is as follows:

"It is appreciated that there are special conditions upon some railroads, in which there is an unusual or unique situation to be met.

"In these circumstances it is understood that any such

railroad is privileged to make representation to the director general as to its individual necessity for a departure from the standard type."

It is obvious that the effect which the principle enunciated in the foregoing will have upon the locomotive situation will depend on how broadly the principle stated is interpreted and applied. Strictly interpreted, it would mean

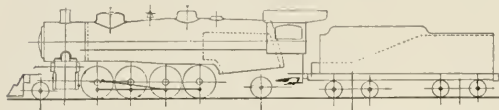

Outline of U. S. Standard Mikado Type Locomotive

that only a few railroads having very special conditions or unique situations would be furnished with any locomotives departing from the standard type. On the other hand, broadly interpreted, it might result in all railroads having

A general outline of the different types of locomotives proposed and a list of the general dimensions and data is given in the illustrations and tables.

There are three designs of tenders to be used with the 12

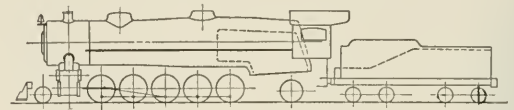

Outline of Standard 2-10-2 Type Locomotive

different locomotives, one having a capacity of 8,000 gal., another 10,000 gal., and the third 12,000 gal., all having a coal capacity of 16 tons. Unless some good and sufficient reason is given with the order for the different locomotives, the tenders shown with the specifications of the locomotives will be provided.

In the main it has been the desire of the committee de-

GENERAL DIMENSIONS OF THE PACIFIC, MOUNTAIN AND SWITCHER STANDARD LOCOMOTIVES FOR THE RAILROAD ADMINISTRATION

Type	Pacific	Pacific	Mountain	Mountain	0-6-0	0-8-0
Driving axle load	55,000 lb.	60,000 lb.	55,000 lb.	60,000 lb.	55,000 lb.	55,000 lb.
Specification Number	5-A	6-A	3-A	4-A	9	10
Gage	4 ft. 8 1/2 in.	4 ft. 8 1/2 in.	4 ft. 8 1/2 in.	4 ft. 8 1/2 in.	4 ft. 8 1/2 in.	4 ft. 8 1/2 in.
Service	Passenger	Passenger	Passenger	Passenger	Switching	Switching
Fuel	Bit. Coal	Bit. Coal	Bit. Coal	Bit. Coal	Bit. Coal	Bit. Coal
Tractive effort	40,700 lb.	43,800 lb.	53,900 lb.	58,000 lb.	39,100 lb.	51,200 lb.
Weight in working order	270,000 lb.	300,000 lb.	320,000 lb.	350,000 lb.	165,000 lb.	220,000 lb.
Weight on drivers	165,000 lb.	180,000 lb.	220,000 lb.	240,000 lb.	165,000 lb.	220,000 lb.
Weight on leading truck	52,000 lb.	60,000 lb.	50,000 lb.	55,000 lb.
Weight on trailing truck	53,000 lb.	60,000 lb.	50,000 lb.	55,000 lb.
Weight of engine and tender in working order	414,000 lb.	444,000 lb.	492,000 lb.	522,000 lb.	309,000 lb.	364,000 lb.
Wheel base, driving	13 ft.	14 ft.	18 ft. 3 in.	18 ft. 3 in.	11 ft. 0 in.	15 ft. 0 in.
Wheel base, total	34 ft. 9 in.	36 ft. 2 in.	40 ft. 0 in.	40 ft. 0 in.	11 ft. 0 in.	15 ft. 0 in.
Wheel base, engine and tender	68 ft. 7 1/2 in.	70 ft. 8 1/2 in.	75 ft. 8 1/2 in.	75 ft. 8 1/2 in.	48 ft. 10 1/2 in.	52 ft. 10 1/2 in.
<i>Ratios</i>						
Weight on drivers ÷ tractive effort	4.1	4.1	4.1	4.1	4.2	4.3
Total weight ÷ tractive effort	6.6	6.8	5.9	6.0	4.2	4.3
Tractive effort × diam. drivers ÷ equivalent heating surface*	656.7	674.1	668.2	637.0	607.6	700
Equivalent heating surface* ÷ grate area	67.8	72.5	78.6	82.4	79.0	80.1
Firebox heating surface ÷ equivalent heating surface,* per cent.	5.8	6.1	6.4	5.9	5.6	5.7
Weight on drivers ÷ equiv. heating surface*	36.5	35.1	39.5	38.2	63.3	58.9
Total weight ÷ equivalent heating surface*	59.7	58.5	57.5	55.7	63.3	58.9
Volume both cylinders	15.9 cu. ft.	18.6 cu. ft.	19.9 cu. ft.	21.4 cu. ft.	11.2 cu. ft.	15.9 cu. ft.
Equivalent heating surface* ÷ vol. cylinders	284.4	276.6	280.9	293.9	232.3	244.5
Grate area ÷ vol. cylinders	4.2	3.8	3.6	3.6	2.9	2.9
<i>Cylinders</i>						
Kind	Simple	Simple	Simple	Simple	Simple	Simple
Diameter and stroke	25 in. by 28 in.	27 in. by 28 in.	27 in. by 30 in.	28 in. by 30 in.	21 in. by 28 in.	25 in. by 28 in.
<i>Valves</i>						
Kind	Piston	Piston	Piston	Piston	Piston	Piston
Diameter	14 in.	14 in.	14 in.	14 in.	10 in.	14 in.
<i>Wheels</i>						
Driving, diameter over tires	73 in.	79 in.	69 in.	69 in.	51 in.	51 in.
<i>Boiler</i>						
Style	Con. W. T.	Con. W. T.	Con. W. T.	Con. W. T.	Straight top	Straight top
Working pressure, lb. per sq. in.	200	200	200	200	190	175
Outside diameter of first ring	76 in.	78 in.	78 in.	86 in.	66 in.	80 in.
Firebox, length and width	114 1/2 in. by 84 1/2 in.	120 1/2 in. by 84 1/2 in.	120 1/2 in. by 84 1/2 in.	114 1/2 in. by 86 1/2 in.	72 1/2 in. by 66 1/2 in.	102 1/2 in. by 66 1/2 in.
Tubes, number and outside diameter	188—2 1/4 in.	216—2 1/4 in.	216—2 1/4 in.	247—2 1/4 in.	158—2 in.	230—2 in.
Flues, number and outside diameter	36—5 1/2 in.	40—5 1/2 in.	40—5 1/2 in.	45—5 1/2 in.	24—5 1/2 in.	36—5 1/2 in.
Tubes and flues, length	19 ft. 0 in.	19 ft. 0 in.	20 ft. 6 in.	20 ft. 6 in.	15 ft. 6 in.	15 ft. 0 in.
Heating surface, tubes	2,091 sq. ft.	2,407 sq. ft.	2,598 sq. ft.	2,970 sq. ft.	1,233 sq. ft.	1,726 sq. ft.
Heating surface, flues	981 sq. ft.	1,090 sq. ft.	1,176 sq. ft.	1,323 sq. ft.	515 sq. ft.	773 sq. ft.
Heating surface, firebox	234 sq. ft.	284 sq. ft.	329 sq. ft.	346 sq. ft.	150 sq. ft.	190 sq. ft.
Heating surface, arch tubes	27 sq. ft.	27 sq. ft.	27 sq. ft.	27 sq. ft.	15 sq. ft.	22 sq. ft.
Heating surface, total	3,333 sq. ft.	3,808 sq. ft.	4,130 sq. ft.	4,666 sq. ft.	1,894 sq. ft.	2,731 sq. ft.
Superheater heating surface	794 sq. ft.	882 sq. ft.	957 sq. ft.	1,078 sq. ft.	475 sq. ft.	637 sq. ft.
Equivalent heating surface	4,524 sq. ft.	5,133 sq. ft.	5,566 sq. ft.	6,283 sq. ft.	2,607 sq. ft.	3,737 sq. ft.
Grate area	66.7 in.	70.8 sq. ft.	70.8 sq. ft.	76.3 sq. ft.	33 sq. ft.	46.6 sq. ft.
<i>Tender</i>						
Tank	Water Bot.	Water Bot.	Water Bot.	Water Bot.	Water Bot.	Water Bot.
Weight	144,000 lb.	144,000 lb.	172,000 lb.	172,000 lb.	144,000 lb.	144,000 lb.
Water capacity	8,000 gal.	8,000 gal.	10,000 gal.	10,000 gal.	8,000 gal.	8,000 gal.
Coal capacity	16 tons	16 tons	16 tons	16 tons	16 tons	16 tons

*Equivalent heating surface = total evaporative heating surface + 1.5 times the superheating surface.

special conditions being allowed to get locomotives adapted to those special conditions. Now, as there is hardly a railway management which has not believed in the past that it had had "special conditions" on at least part of its lines, the broad interpretation of the principle would result in the ordering of many locomotives besides the standard locomotives.

signing the locomotives to provide designs which will best meet average conditions. For instance, freight locomotives of the Mikado, Santa Fe and Mallet types have been evolved which have the following tractive efforts: 54,600 lb., 60,000 lb., 69,400 lb., 74,000 lb., 80,300 lb. and 106,000 lb. This covers the range of tractive efforts for freight service fairly well. The boiler factors of the heavy Mikado and of both

of the Santa Fe type locomotives are sufficiently high to permit increased tractive effort by increasing the boiler pressure. The Pacific and Mountain type locomotives for passenger service have tractive efforts of 40,700 lb., 43,800 lb., 53,900 lb. and 58,000 lb. The six-wheel and eight-wheel switchers have tractive efforts of 39,100 lb. and 51,200 lb. respectively.

There are two sizes of drivers used on the freight engines: 63 in. in diameter for both Mikados and the heavy Santa Fe

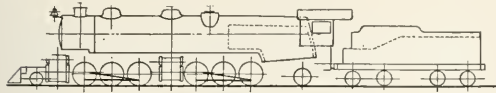

Outline of Standard 2-6-6-2 Mallet

type and 57 in. in diameter for the light Santa Fe and both the Mallet types. The light Pacific type locomotive has a 73-in. wheel, the heavy Pacific a 79-in. wheel and both the Mountain types a 69-in. wheel. The wheels of both switchers are 51 in. in diameter. Superheaters and brick arches are used on all of the locomotives, and it has been said that the Santa Fe and Mallet types will be equipped with stokers. All designs except the switchers are provided with combustion chambers. It may be said that with a possible exception of the two Pacific type locomotives, the boilers are of ample capacity.

The locomotives are all designed to traverse 19-deg. curves

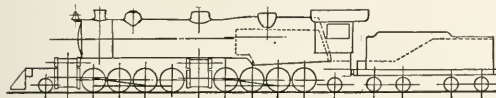

Outline of Standard 2-8-8-2 Mallet

and grades of two per cent. The clearance limitations are practically alike, the over-all height being 15 ft., with the exception of the heavy Santa Fe type and the 2-8-8-2 Mallet, which have height clearance of 15 ft. 9 in. The width over cylinders is 10 feet. 4 in. for all designs, with the exception of the heavy Santa Fe type and the large Mallet, which is 10 ft. 9 in. and the smaller Mallet, which is 10 ft. 6 in. The width over cab body and over cab eaves, including the cab handles, is the same for all designs, being 10 ft. in the first case and 10 ft. 2 in. in the second.

A casual study of these limitations indicates that there will be some difficulties, particularly around terminals, due

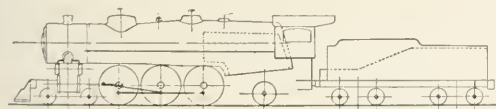

Outline of Standard Pacific Type

to low bridges. The Boston & Maine has three bridges around Boston with a clearance of 14 ft. 9 in. There are the same limitations on some bridges in the vicinity of the Union Station in Cincinnati; between the Chicago Terminal and the California yards of the North Western there is a limitation of 14 ft. 10 in. and on the C. B. & Q. between St. Louis and East St. Louis the limitations are 14 ft. 7 in. On the Michigan Central at Detroit the minimum clearance is 14 ft. 3 in. On the main line of the Chesapeake & Ohio, between Charlottesville and Clifton Forge, Va., a distance of 116 miles, the minimum clearance is 15 ft. This is in a mountainous territory and it will be impossible to use either

the heavy Santa Fe type or the 2-8-8-2 Mallet. The 2-6-6-2 Mallet will, however, come within these limitations. The Hoosic tunnel of the Boston & Maine has a height clearance of 14 ft. 8 in., which will prevent any of these standard locomotives passing through this tunnel.

Present indications are that about 1,000 of the standard locomotives will be bought at first and that they will be intended primarily to serve as a flying squadron which can be used on the lines which have not enough locomotives to handle all the traffic which must be moved over them.

It is estimated that there are now about 600 engines

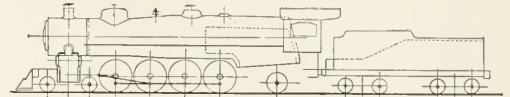

Outline of Standard Mountain Type

in service on foreign lines. As the standard locomotives are delivered it is probable that they will replace these foreign engines and that the foreign engines will be returned to the home lines. While the foreign engines have been taken from numerous railways, they are being used on a comparatively small number of lines. Therefore, if the standard locomotives are used mainly to replace them, the result will be that in the early stages, at least, they will be used on only a comparatively small number of roads. As a matter of fact, the Railroad Administration does not know where it will send the standard locomotives at first, but it is considered by some officers of the administration that

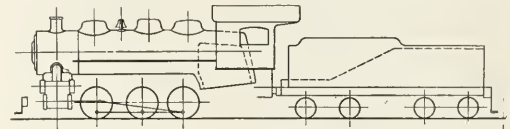

Outline of Standard Six-Wheel Switcher

it will be logical to send home as rapidly as possible the engines that are now off the lines of the owning roads and to replace them with the standard locomotives as rapidly as they are built.

The interchange of power is questionable practice at any time. Under existing conditions, however, it has been found necessary. If standard locomotives are considered at all they should be considered for only such service and only that number which is necessary for a liquid reserve should be built.

Probably whether additional locomotives of the same types

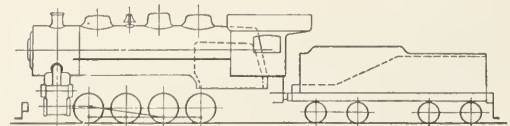

Outline of Standard Eight-Wheel Switcher

or of other standard types will be ordered will depend to a considerable extent on the results secured with these locomotives. The Railroad Administration intends to appoint a special committee to study the results of the operation of the standard locomotives. One thing seems certain and this is that the principle of standardization of locomotives has not

been finally established even for the period of government control and the future developments and discussion have yet to determine whether it will finally become firmly established.

100 PER CENT GOAL IN RAILROAD LIBERTY LOAN CAMPAIGN

"I hope that every railroad employe in the United States will lend all the money he can, consistently with his individual circumstances, to his government in buying Liberty Bonds," says Director General McAdoo in Circular No. 24 on the Railroad Wage Commission.

"In lending your money to the government you not only save the money for yourselves, but you help every gallant American soldier and sailor who is fighting in this war now to save your lives and liberties and to make the world safe for democracy."

With an organization that reaches every employe in railway service, from the presidents down, the railway men of this country are enthusiastically working to take a large share of the total issue of the Third Liberty Loan, and are doing their utmost to live up to their brothers who are making a record for themselves in the railway engineer regiments in France.

The Eastern Committee, of which President Underwood of the Erie is chairman, reports that the Liberty Loan campaign is making fine progress on the railways of the eastern regional district. Details as to the number of subscribers and the amounts taken, however, have only been received from a few roads. Up to Wednesday, April 24, subscrip-

tion would be *more than double those for the second loan.*

About 15,000 individual subscriptions totaling about \$1,400,000 had been received from employes on the railroad east of Buffalo, and about 10,000 subscribers had taken \$1,120,000 on the line west of Buffalo, up to this date, making the total for employes of both major portions of the company line \$2,520,000 recorded thus far. In the second loan, 20,894 employes of the New York Central Railroad proper subscribed for \$1,343,050.

The Lackawanna is one of the roads which is already beginning to talk about 100 per cent subscriptions. Up to Wednesday, April 24, only the road was able to report the following percentages of subscribers among the employes:

	Per cent
*Station employes	95.8
Conductors	88.9
Trainmen	67.4
Switchmen	81.1
Yardmasters and clerks	81.4
Superintendents' offices	97.5
Shoppers, carmen, roadhousemen, etc.	73.9
Locomotive engineers	65.9
Locomotive firemen	44.2

*The above figures do not include the freight house laborers.

Returns from western railroads received up till noon of April 24 show total subscriptions to the Third Liberty Loan of \$37,353,000, or an increase of \$1,759,000 in the last 24 hours; 465,000 out of 751,000 employes of the western roads have so far subscribed to the loan. The Rock Island system led with subscriptions for 98.55 per cent of its employes.

Then western railroads had reported up to Monday, April 22, subscriptions exceeding \$1,000,000. They were:

Road	Per cent of employes	Subscriptions	Average
Chicago, Rock Island & Pacific	96.22	\$2,689,150	69.21
Chicago, Milwaukee & St. Paul	74.30	2,461,150	69.84
Northern Pacific	83.58	2,398,450	90.00
Chicago & North Western	60.19	2,337,200	71.90
Atchison, Topeka & Santa Fe	49.43	2,327,350	73.60
Great Northern	58.83	1,987,050	99.35
Missouri Pacific	71.25	1,961,450	70.97
Chicago, Burlington & Quincy	50.44	1,714,450	73.51
Union Pacific	55.21	1,172,800	73.88
Southern Pacific	33.21	1,109,850	71.90

COMMITTEES OF OFFICERS AND EMPLOYEES

The Liberty Loan campaign on the railroads has been so well organized that every railway man has been reached by the members of a committee in his department or branch of service.

The organization at the top includes three committees of railroad presidents, one committee each for the three regional districts.

The eastern regional district committee is headed by F. D. Underwood, president of the Erie, and includes the following members: W. H. Truesdale, president of the Delaware, Lackawanna & Western; Frank Trumbull, chairman of the board of the Chesapeake & Ohio; E. E. Loomis, president of the Lehigh Valley; L. F. Loree, president of the Delaware & Hudson; Howard Elliott, chairman of the committee on intercorporate relations of the New York, New Haven & Hartford, and John B. Dennis of Blair & Co.

The western committee is headed by W. S. Bied, president of the Chicago & Alton, and its members include J. E. Gorman, president of the Chicago, Rock Island & Pacific; H. E. Byram, president of the Chicago, Milwaukee & St. Paul; H. G. Hetzler, president of the Chicago & Western Indiana; C. H. Markham, president of the Illinois Central; A. M. Schoyer, resident vice-president of the Pennsylvania Lines; C. G. Burnham, executive vice-president of the Chicago, Burlington & Quincy.

E. T. Lamb, president of the Atlanta, Birmingham & Atlantic, is chairman of the Liberty Loan committee which has been appointed for the southern regional district. The other members of the committee are H. W. Miller, vice-president of the Southern; C. A. Wickersham, general man-



New York Central Honor Flag.

Awarded to each department showing 75 per cent of personnel subscribed. A star is placed in the field beneath the eagle's wings for each additional 5 per cent. Some departments have reported "100 per cent subscribed" and claimed the honor flag with 5 stars. The flag has border and frame of deep red, with lettering and decorations in blue and white, the background being buff. It is 30 by 20 in.

tions were reported from 94,737 employes for a total of \$6,000,260.

Judging by the reports from two of the eastern roads, the totals should show a great increase over the figures for the second loan and the percentage of employes subscribing should reach well into the nineties.

The secretary of the general committee in charge of the canvass of employes of the New York Central Lines for sale of the Third Liberty Loan bonds, which is engaging the organized work of over 3,500 employes on committees and teams on the system, stated that returns already received at general headquarters in Grand Central Terminal, New York, and tabulated up to Friday, April 26, assured that the subscriptions by New York Central Railroad employes (other lines of the system not included) for the

ager of the Georgia Railroad; and W. L. Stanley, assistant to the president of the Seaboard Air Line.

The president of every railroad in the country has been called upon to direct the work on his railroad. To make sure that no employee will lack a chance to know about the loan or to subscribe to the extent of his ability committees have been formed of employees in every office, shop and terminal.

On the New York Central, to take one example, there are 650 divisional and departmental committees, each with specific responsibility, territory and lists, these embracing as active workers more than 3,500 employees.

A specially-designed "Honor Flag" is awarded to each department showing 75 per cent of its personnel as subscribers to bonds, a star being added for each additional 5 per cent. Already numerous departments have reported "100 per cent subscribed" and claimed the flag with five stars.

Girl employees with brothers or family members at the front form a unique branch of the New York Central organization selling Liberty bonds. They are the special "storm troops" or "shock squads," as it were, of the army of 3,500 bond canvassers, being used to win over those "hard cases" when other appeals have failed. When an employee who is well able to invest rests all efforts and is reported by the regular "team" as hopelessly indifferent or laggard, a "squad" of the girls makes the final effort. Every one of the girls has a brother, husband or father in the fighting forces, this being a necessary qualification, and with thoughts of the needs of their loved ones "over there" which the bond money would supply as an inspiration, their pleas seldom fail to convert reluctant investors.

"SAFETY FIRST" YIELDS TO "LIBERTY FIRST"

For the final week of the bond-selling on the New York Central, the "Safety First" organization has changed its title to "Liberty First." The regular "safety meetings" held by employees under direction of local committees have been devoted to arousing enthusiasm for the third bond issue.

Marcus A. Dow, general safety agent of the system, as this is written is holding a series of Liberty bond mass-meetings for railroad employees, on a fast tour that will cover all the big centers to Buffalo. Commencing at the Harmon shops, the schedule includes big rallies for employees at West Albany, Rensselaer, Utica, Frankfort, Syracuse, Depew, Rochester, Buffalo and Niagara Falls.

Two veterans of the war, invalidated for wounds, accompanied Mr. Dow and addressed the railroad employees' gatherings, telling of conditions and their personal experiences in the trenches. These were Private L. C. Burgess, a bomber who saw three years' service with the famous Canadian "Princess Pats" and lost an eye for liberty, and Private H. J. Pickell, who served three years with the 24th Battalion, Canadian Infantry, and was wounded at Vimy Ridge.

The meetings in shops, roundhouses, at stations and in switching yards have been marked by the greatest enthusiasm, the railroad men being particularly interested in hearing about the American railway engineers who threw down their shovels and seized rifles at Cambrai, thereby becoming the first of our expeditionary forces in battle.

One of the features of the campaign on the Erie is a Liberty Loan train. This train was run from Hammond, Ind., to Jersey City and stopped at the division points and shops on the route. With the train was the Erie's general office band. General Manager R. S. Parsons accompanied the train and he and the local speakers addressed the Erie employees at the important centers along the route.

C. H. Markham, regional director of the Southern railroads, has sent out two special war relic trains, which left

Atlanta April 6, on a tour to last 27 days. One train covered central and eastern Tennessee, all of Georgia and a large part of Florida. The second train covered portions of central Tennessee, all of Alabama, southern Mississippi and southern Louisiana. Each train carried ten American artillery officers accompanied by French and Canadian soldiers and officers and Liberty Loan speakers.

Apparently the work of some of the committees has been as insistent as it has been enthusiastic. The Altoona Tribune, for example, had the following interesting story in a recent issue:

"Twenty-six men in one Altoona machine shop department yesterday placed a strenuous objection with officials when three of their mates failed to acquire war bonds of the present issue. An ultimatum was issued and if the trio continues to ignore the solicitors after 7 a. m. today they must quit or the twenty-six loyalists will.

"Several clerks in one of the offices at the same shops yesterday made it known they weren't going to wear the red-white-and-blue button designating the subscribers to the third loan. A petition was hastily drawn up and all other workers in the office signed it, stating they would resign if the status of the affair wasn't changed favorably."

CENSUS STATISTICS OF RAILROAD REPAIR SHOPS

In 1914 there were 1,362 steam railroad repair shops, which shops hired on the average 361,925 persons. The value of the products of these shops was \$514,041,225. For the same year there were 103 establishments engaged in the manufacture of freight and passenger cars for steam railroad service. These establishments, on the average, hired

	Census year.	Number of establishments.	Average number of wage earners.	Value of products.	Value added by manufacture.
All classes.....	1914 1909	1,362 1,145	339,518 282,174	\$514,041,225 405,600,727	\$270,212,618 226,187,315
Less than \$5,000.....	1914 1909	44 52	115 152	133,531 163,034	81,776 98,548
\$5,000 to \$30,000.....	1914 1909	154 149	1,584 1,515	1,865,296 1,760,898	1,202,354 1,124,545
\$30,000 to \$100,000.....	1914 1909	358 286	14,430 12,059	19,548,303 14,701,863	12,158,925 8,963,187
\$100,000 to \$1,000,000.....	1914 1909	64 564	168,586 152,334	237,177,633 199,863,116	133,985,665 109,433,358
\$1,000,000 and over.....	1914 1909	122 94	154,803 115,914	255,810,562 189,111,816	122,783,808 86,507,677
Percent distribution:					
Less than \$5,000.....	1914 1909	3.2 4.5	(1) 0.1	(1) (1)	(1) (1)
\$5,000 to \$20,000.....	1914 1909	11.3 13.0	0.5 0.5	0.4 0.4	0.4 0.5
\$20,000 to \$100,000.....	1914 1909	26.3 25.0	4.3 4.3	3.8 3.6	4.5 4.3
\$100,000 to \$1,000,000.....	1914 1909	50.2 49.3	49.7 54.1	46.1 49.3	49.6 53.1
\$1,000,000 and over.....	1914 1909	9.0 8.2	45.6 41.1	49.7 46.6	45.4 42.0

¹ Less than one-tenth of 1 per cent.

The Railroad Repair Shops Divided by Value of Products

58,988 persons and turned out a product the total value of which was \$194,775,699.

These figures were taken from a report of the Bureau of the Census entitled Steam and Electric Cars and Railroad Repair Shops, made public early in March, which presents statistics for establishments building cars for use on steam railroads; those building cars for use on electric railroads;

the operations of repair shops by steam railroad companies, and the operations of repair shops by electric railroad companies. An abstract of that portion of the report dealing with railroad repair shops follows. The original numbers of the tables have been retained.

Scope of the combined industry.—This industry is divided for census purposes into two classes—cars and general shop construction and repairs by steam-railroad companies, and cars and general shop construction and repairs by electric-railroad companies.

Every steam or electric railroad company of any magni-

the important industries covered by the statistics of manufactures.

Size of establishments.—The tendency of the industry to become concentrated in large establishments is indicated by the statistics given in Tables 29 and 30.

Fuel.—Coal is the principal class of fuel used in steam-railroad repair shops. In 1914, 506,696 tons of anthracite and 5,486,405 tons of bituminous coal were consumed in this industry. The other fuels used were coke, 79,597 tons; oil, 2,508,703 barrels; and gas, 1,829,902,000 cubic feet.

SPECIAL STATISTICS OF REPAIR SHOPS

Table 32 gives in detail the statistics of steam-railroad repair shops for 1914, 1909, 1904 and 1899.

The table shows fewer locomotives and cars built in steam-railroad repair shops in 1914 than during some of the earlier census years. The number of locomotives decreased by 85, or 31.2 per cent, from 1899 to 1914, and the number of cars built, by 16,188, or 60.1 per cent, but the total value of work done in these shops shows an increase of 135.5 per cent for the 15 years.

In 1914 the motive power and machinery department reported 46.1 per cent of the total value of products; car department, 47.3 per cent; bridge and building department, six-tenths of 1 per cent; and all other, or unclassified products, 6.1 per cent.

Table 30

WAGE EARNERS PER ESTABLISHMENT.	NUMBER OF ESTABLISHMENTS.				AVERAGE NUMBER OF WAGE EARNERS.			
	1914		1909		1914		1909	
	Per cent of total.		Per cent of total.		Per cent of total.		Per cent of total.	
All establishments.....	1,362	1,145	100.0	100.0	339,518	252,174	100.0	100.0
1 to 5 wage earners.....	76	87	5.6	7.6	234	281	0.1	0.1
6 to 20 wage earners.....	194	164	14.2	14.3	2,503	2,128	0.7	0.8
21 to 50 wage earners.....	202	148	14.8	12.9	6,840	4,930	2.0	1.8
51 to 100 wage earners.....	213	162	15.6	14.1	15,634	11,548	4.6	4.2
101 to 250 wage earners.....	287	238	21.1	20.8	45,788	37,247	13.5	13.2
251 to 500 wage earners.....	197	180	14.5	15.7	67,492	63,821	19.9	22.6
501 to 1,000 wage earners.....	131	122	9.6	10.7	91,041	81,619	28.8	30.0
Over 1,000 wage earners.....	62	44	4.6	3.8	109,986	77,237	32.4	27.4

Railroad Repair Shops Divided by Number of Employees

tude operates one or more repair shops, chiefly for the purpose of maintaining the efficiency of the rolling stock. Such shops often manufacture complete cars and some of them manufacture complete locomotives. While the bulk of the work of the repair shops is on the rolling stock, they also do shopwork in connection with the construction and repair of bridges, buildings, etc. Most of the work done is on rolling stock operated by the company, but some compa-

EFFICIENCY AND FATIGUE IN BRITISH MUNITIONS FACTORIES.—An interim report on "Industrial Efficiency and Fatigue," issued during the summer by the Health of Munition Workers Committee of the British Ministry of Munitions, has been reproduced in bulletin 230 of the Bureau of Labor Statistics of the U. S. Department of Labor. According to this report, night-work on the whole is regarded as undesirable, although there is no significant difference between the rate of output in night and day shifts managed on the discontinuous system which is preferred to

Table 32

CLASS OF WORK.	1914	1909	1904	1899 ¹	CLASS OF WORK.	1914	1909	1904	1899 ¹
Total value.....	\$14,041,225	\$405,000,727	\$309,775,089	\$218,238,277	Car department, value—Contd.				
Motive power and machinery department, value.....	\$236,723,724	\$184,971,870	\$149,643,953	\$94,447,260	Cars built, value—Continued.				
Locomotives built—					Other—				
Number.....	157	215	118	272	Number.....	308	359	2,000	(?)
Value.....	\$3,594,003	\$3,289,110	\$1,853,839	\$3,276,393	Value.....	\$253,005	\$267,153	\$645,392	(?)
Repairs to locomotives, motors, etc.....	\$169,057,932	\$127,028,778	\$101,326,805	\$57,383,143	Repairs to cars of all kinds.....	\$183,753,538	\$147,194,065	\$103,319,032	\$74,665,500
Work for other corporations.....	\$7,053,430	\$4,735,004	\$5,681,807	\$3,338,589	Work for other corporations.....	\$14,819,984	\$8,784,239	\$5,946,990	\$7,084,837
All other products or work.....	\$87,018,359	\$49,018,953	\$40,781,902	\$30,449,135	All other products or work.....	\$32,403,269	\$30,164,464	\$24,492,787	\$20,104,843
Car department, value.....	\$242,976,771	\$199,768,939	\$149,748,820	\$118,376,552	Bridge and building department (shopwork), value.....	\$3,127,644	\$2,799,898	\$5,096,141	\$5,414,465
Cars built, value.....	\$11,999,983	\$13,326,171	\$12,990,011	\$16,821,352	Repairs and renewals.....	\$2,449,821	\$1,906,737	\$4,351,487	\$3,367,170
Passenger—					Work for other corporations.....	\$37,061	\$46,496	\$40,581	\$241,626
Number.....	123	218	414	390	All other products or work.....	\$640,762	\$846,665	\$704,073	\$1,235,669
Value.....	\$1,233,302	\$1,291,354	\$2,337,977	\$1,441,733	All other products and work not classified, value.....	\$31,213,083	\$18,060,020	\$5,286,175	(?)
Freight—									
Number.....	10,314	13,972	14,742	26,543					
Value.....	\$10,514,676	\$11,767,664	\$10,006,612	\$15,079,619					

¹ Includes \$121,619 reported for Alaska.

² Not reported

Statistics of Railroad Repair Shops, 1899, 1904, 1909 and 1914

nies do work of this character for others. The products are not ordinarily given a selling or contract value. The amount reported as the value for 1914 usually represented the cost of materials, salaries, wages, rent, and taxes. At prior censuses a miscellaneous expense item was reported, which to that extent increased the value of products. For steam-railroad repair shops this item amounted to \$3,946,043 in 1904 and \$5,886,066 in 1909, and for electric-railroad repair shops \$285,483 in 1904 and \$702,536 in 1909. The steam-railroad repair shops are far more important than the electric-railroad repair shops. In fact, measured by the number of persons employed, they constitute one of

continuous night-work, the latter being productive of definitely less output. The report shows that health and efficiency of workers are influenced by the earnings. In one factory 17 girls drilling fuses and working on the piece-rate basis, in one week increased their output by 24 per cent on the day-shift and by 40 per cent on the night-shift over their output when working on a time-wage basis. Among the men sleepiness on the night-shift, headache, footache, and muscular pains, together with nervous symptoms, are probably the most common signs of overwork. Eighty per cent of the lost time among the 1,543 men was due to sickness and 20 per cent to accident.

THE DYNAMIC AUGMENT PROBLEM*

The Need for Reducing the Weight of Reciprocating Parts; How the Reduction May Be Effected

BY E. W. STRONG

American Vanadium Company, Pittsburgh, Pa.

IN one respect there has been, generally speaking, no progress in locomotive design during the last decade: to the contrary, approved practice is not on a par with that of 10 years ago. This is in regard to the weights of the reciprocating and revolving parts per unit of load. H. A. F. Campbell in his series of articles on "Reciprocating and Revolving Parts," which began in the *Railway Age Gazette, Mechanical Edition*, March, 1915, presents data which discloses this fact very forcefully. And this condition exists

in this case, only 35 per cent of the reciprocating weight was balanced. The main counterweight lacks 691 lb. of balancing the revolving weights on the main pin. The average excess balance in the other wheels was 408 lb. Fig. 1 represents graphically the maximum dynamic augment in the main and other wheels of the same engine at various speeds from 15 miles per hour up to diameter speed. At 40 miles per hour, which is probably the maximum speed which this engine would ever attain, the dynamic augment in the main and other wheels is respectively 14,200 lb. and 8,400 lb., or 42 $\frac{1}{2}$ per cent and 25 per cent, respectively, of the static weight of the wheel on the rail. Further, when the pressure of the main wheel on the rail is at its maximum the pressure of the other wheels is at a minimum. The charts

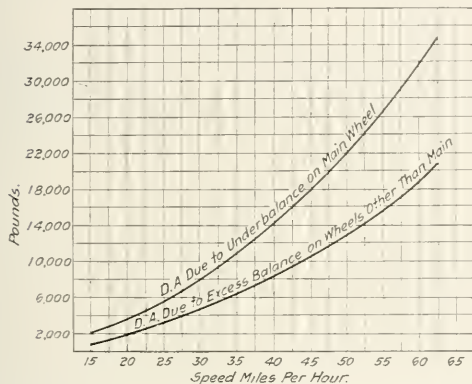

Fig. 1—Dynamic Augment in Wheels of a 2-10-2 Type Locomotive at Various Speeds

in face of the fact that never before has there been greater opportunity for betterment by taking full advantage of the developments in locomotive materials.

While it is perfectly true that with the enormous increase in wheel loads the ratio between the dynamic augment at diameter speed \ddagger and the static weight per wheel is even greater today in high speed engines than it was 25 years ago, it is equally true that present tremendous static wheel loads more nearly approach the capacity of the track. There is less margin of track capacity and less opportunity for increasing it. Furthermore, it is no longer the high speed engine which requires the most serious consideration, but the freight engine. And in the latter class it is not the dynamic augment due to the weight required to balance the reciprocating parts, but that due to lack of weight in the main counterweight to balance the revolving weight on the main crank pin.

This is particularly true of the 2-10-2 type locomotive. In most existing engines of this type the lack of balance for revolving weight in the main wheel causes a much greater dynamic augment than the excess balance in the other wheels for the reciprocating parts. The dynamic augment in the main wheel is, of course, directly opposite to that in the other wheels.

As an example, an engine having the proportions shown in Table I has been selected.

*From a paper read before the February, 1918, meeting of the New York Railroad Club.
 \ddagger Speed in miles per hour equal to the diameter of the drivers in inches.

TABLE I.—PROPORTIONS OF IMPROPERLY BALANCED ENGINES

Boiler pressure	200 lb.
Cylinders	31 in. by 32 in.
Drivers, diameter	63 in.
Total weight in working order	401,000 lb.
Weight on drivers	335,000 lb.
Weight of reciprocating parts per side	2,604 lb.
Ratio of weight of reciprocating parts to total weight of engine	1/152
Piston thrust per pound of reciprocating weight	57.9 lb.
Revolving weight on main wheel	1,912 lb.

and the above figures refer to the dynamic augments in single wheels only and not to the combined augments of the counterbalances in the corresponding pairs.

The above example is not extreme. The engine selected is a very appropriate example, because it was built largely to the railroad's designs. It is the mechanical departments of the roads that must be impressed with the necessity of improvement in existing counterbalance conditions.

Fig. 2 is a chart similar to Fig. 1, representing the dynamic augment in a representative 4-6-2 type locomotive with 60 per cent of the weight of the reciprocating parts

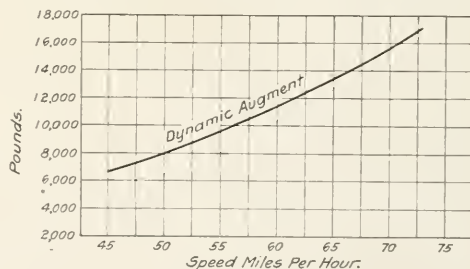

Fig. 2—Maximum Dynamic Augment in Wheels of a Pacific Type Locomotive

balanced. In this case, of course, there was no difficulty in fully balancing the revolving weights on the main pin. This engine has the proportions shown in Table II.

The factor which made possible the development of the Pennsylvania Class E6 engines was the use of especially light reciprocating parts. With 66,500 lb. on a single pair of drivers, these engines established a record. By so reducing the weight of the reciprocating parts as to keep the dynamic augment within 50 per cent of the static weight on

a wheel point, it was possible safely to use this enormous axle load. In fact, these engines produce less strain on track and bridges than many having 10,000 lb. to 12,000 lb. less weight on drivers.

The locomotive impact tests made by the Chicago, Burlington & Quincy point very clearly to the possibilities of using heavier and more powerful units on track that is at present

TABLE II.—PROPORTIONS OF PROPERLY BALANCED ENGINE

Boiler pressure	200 lb.
Cylinders	27 in. by 28 in.
Drivers, diameter	305,500 lb.
Weight of reciprocating parts, per side	197,300 lb.
Ratio of weight of reciprocating parts to total weight of engine	1/16.2
Piston thrust per pound of reciprocating weight	64 lb.

loaded to capacity, through simply lightening the reciprocating and revolving parts, with consequent reduction in the dynamic augment. Four locomotives were tested, two of the 2-10-2 type and two of the Pacific type. Of each pair, one engine had especially light reciprocating parts made of heat-treated alloy steel and the other parts made of ordinary steel. The two 2-10-2 type engines had approximately the same weight on drivers, while the reciprocating parts in one weighed 16 per cent less than in the other. With the Pacific type locomotives, the one with light reciprocating parts was 16,600 lb. heavier on drivers and had 6,600 lb. greater tractive effort, while the weight of the reciprocating parts was 5 per cent less than in the other.

The results showed that in the case of the 2-10-2 type engines, the maximum impact on the rail of the one with light reciprocating parts was 35 per cent less than that of the other. In both cases the speed was about 40 miles per hour. In the case of the Pacifics, the one with the light reciprocating parts, though 10 per cent heavier on drivers than the other, produced less stress on track and bridges.

By taking advantage of the greater strength of alloy and special steel forgings and castings to use increased unit stresses, by using hollow bored crank pins and piston rods, rolled steel or alloy and special cast steel pistons, and by

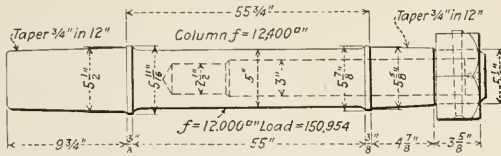

Fig. 3—Design of Piston Rod of Annealed Carbon-Vanadium Steel for 2-10-2 Type Locomotive

special care in the design of all details, a large percentage of saving can be effected in the weights of reciprocating parts.

By far the great majority of roads using alloy steel forgings have been content to utilize them to provide an increased

TABLE III.—WEIGHT OF RECIPROCATING PARTS OF THREE CLASSES OF PENNSYLVANIA LOCOMOTIVES.

	4-4-2	4-6-2	2-8-2
Total weight	240,000 lb.	305,000 lb.	315,500 lb.
Weight on drivers	133,100 lb.	200,000 lb.	238,000 lb.
Cylinders	23 1/2 by 26 in.	27 in. by 28 in.	27 in. by 30 in.
Diameter of drivers	80 in.	80 in.	62 in.
Piston thrust	89,000 lb.	114,000 lb.	114,000 lb.
Weight of reciprocating parts per side	1,014 lb.	1,376 lb.	1,470 lb.
Piston thrust per pound reciprocating weight	87 lb.	83 lb.	77 lb.

factor of safety. The few cases in which advantage has been taken of high tensile steels to reduce weights of reciprocating parts serve to show the possibilities. The Pennsylvania Railroad was the first to use especially light reciprocating parts;

and still furnishes the most conspicuous example of such practice.

The weights of the reciprocating parts and the general proportions of three of their standard classes of road engines are given in Table III. For main and side rods, piston rods, pins and valve motion parts they use carbon steel, heat-treated to give a minimum elastic limit of 50,000 lb., and 80,000 lb. tensile strength. Rolled steel pistons are employed; while the crossheads are made of .40 carbon electric furnace cast steel, having a tensile strength of 70,000 to 80,000 lb. per sq. in. By using sections which take full advantage of the greater strength of the materials employed, combined with the greatest care and attention to detail de-

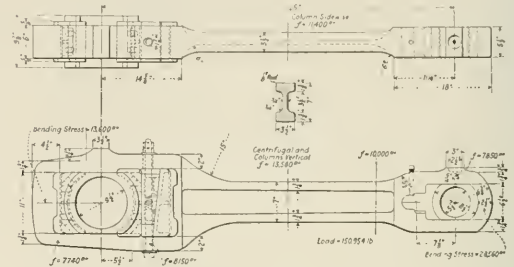

Fig. 4—Main Rod for 2-10-2 Type Locomotive Made of Annealed Carbon-Vanadium Steel

sign, exceptionally light reciprocating parts have been attained.

The Pacific and 2-10-2 type locomotives on the C. B. & Q. previously referred to, are other well known examples of the application of especially light reciprocating parts. On these engines, heat-treated Nichrome steel was used for the piston rods, connecting rods, stub straps, pins and eccentric cranks. Pistons and crossheads were made of .40 carbon cast steel. In the 2-10-2 type engines, the weight of the reciprocating parts was reduced 16 per cent. In addition, the weight of the revolving parts on the main pin were so reduced as to make it possible to omit counterweight bobs on the main axle. In previous sister engines with ordinary carbon steel parts, it had been necessary to follow such practice. A total saving in weight of 1,023 lb. per side was effected. The increase in the various calculated maximum stresses in the main and side rods as compared with the builders' standard practice for plain carbon steel averaged 21 per cent.

One of the most recent instances of utilizing higher tensile steels to lighten reciprocating parts is furnished by the powerful Pacifics built for the El Paso & Southwestern. For this purpose, heat-treated chrome-vanadium steel was specified for the main and side rods, piston rods, crank pins, eccentric cranks and crossheads. The engines had the following general proportions:

Boiler pressure	200 lb.
Total weight in working order	311,500 lb.
Weight on drivers	190,000 lb.
Cylinders	27 in. by 28 in.
Diameter of drivers	73 in.
Piston thrust	114,500 lb.
Weight of reciprocating parts	1,628 lb.
Piston thrust per pound reciprocating weight	71 lb.

By an increase in unit stresses of only 10 per cent as compared with the builders' standard practice for ordinary carbon steel, and by the use of hollow bored crank pins and piston rods, and a double bushing solid back end on the main rod, a total saving of 369 lb. per side, or 13 per cent of the weight of the parts affected, was obtained. Of this, 128 lb. was in the reciprocating parts. This meant 1,880 lb. re-

duction in the dynamic augment per wheel at 75 miles per hour.

In each of the above instances of weight reductions, heat-treated forgings have been the means selected for that end. But most roads lack equipment for heat-treatment. This has been the chief obstacle to the general adoption of heat-treated forgings. It operates particularly in repair work, where for any reason the forging has to be locally heated, thereby destroying the effect of the heat-treatment. The more simple a steel and the more simple its treatment, the better adapted it is to American railroad conditions.

To meet all the special conditions entering into locomotive design, construction and maintenance, the American Vanadium Company, about five years ago, developed a type of vanadium steel that without heat-treatment other than the usual simple annealing gives all the physical requirements for heat-treated (quenched and tempered) plain carbon steel. This steel, known as carbon-vanadium, is one of the simplest types of alloy steels, being a plain carbon steel with vanadium alone added.

Tests of solid driving axles 11 in. in diameter of this type of steel, annealed, gave the following physical properties:

Elastic limit, lb. per sq. in.	59,260	60,430
Tensile strength, lb. per sq. in.	88,270	92,520
Elongation in 2 in., per cent.	25.5	24.5
Reduction of area, per cent.	48.9	50.0

Compared with ordinary annealed carbon forgings, carbon-vanadium steel has over 25 per cent higher elastic limit,

total reduction of 622 lb., or 155 lb. per wheel, in the excess balance that had to be added to the counterweights of the other wheels. This means a reduction of 3,200 lb. in the maximum rail pressure at 40 miles per hour on any one of these wheel points, assuming that all the weight saved in the reciprocating parts would be taken out of the counterweights.

By the use of vanadium cast steel for crossheads and pistons, or rolled steel pistons, and by special care in design, considerable additional weight reduction could be effected, probably 250 lb. at a very conservative estimate.

The total estimated saving in weight in the reciprocating and revolving parts through the modified designs is 921 lb. per side. Details of the redesigned piston rod, main rod and side rods are shown in Figs. 3, 4 and 5.

Apart from its relation to the dynamic augment, this weight taken out of the running gear could be added to the boiler. The above amount combined with what could be saved by using hollow bored axles of carbon-vanadium steel, would make it possible to add 1½ in. to 2 in. to the diameter of the boiler, without increasing the total weight of the engine.

In the case of the Pacific type locomotive, the results show a saving of 260 lb. in the weights of the piston rod and front end of main rod. This means 86 lb. reduction in the excess balance in the wheel counterweights, which would result in 3,900 lb. decrease in maximum rail pressure on a wheel point at diameter speed.

Piston thrust was taken as full boiler pressure times the

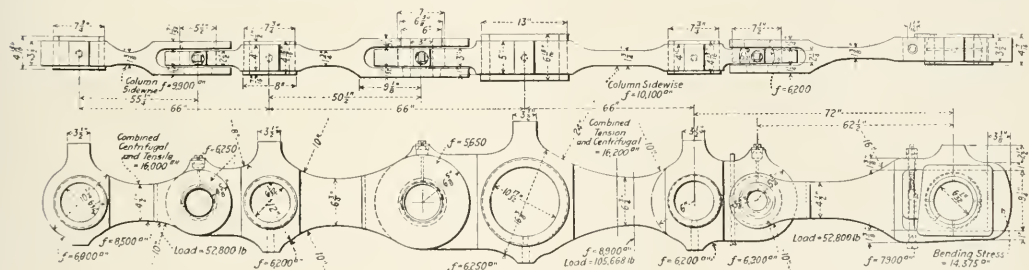

Fig. 5—Design of 2-10-2 Type Side Rods Based on Unit Stresses Increased in Proportion to Higher Elastic Limit of Annealed Carbon-Vanadium Steel

or useful strength. When higher physical properties are desired than can be obtained by simple annealing, results can be obtained by heat-treatment that approximate those from the more complex alloy steels.

A study was recently made of the amount of weight that could be saved in the reciprocating and revolving parts through an increase in unit stresses over approved practice for plain carbon steel, equal in proportion to the increase in the minimum elastic limit of annealed carbon-vanadium steel as compared with plain carbon steel. Several representative heavy locomotives were selected for investigation. The builders' adopted practice for maximum allowable unit stresses for plain carbon steel was taken as the base; and new sections worked out, keeping within the limit of 25 per cent increase over these stresses.

Two of these locomotives were the ones for which the dynamic augment curves shown in Figs. 1 and 2 were plotted. In the case of the 2-10-2 type, the results show a reduction of 326 lb. in the weight of the revolving parts on the main pin. This would mean a reduction of 6,700 lb. in the present dynamic augment in the main wheel at a speed of 40 miles per hour, due to the existing lack of 691 lb. in the main counterweight. The above saving in weight, and the reduction of 296 lb. in the reciprocating parts gives a

area of the piston. The stresses were calculated by the formulae in use by the builders.

Extended piston rods were applied to both the 2-10-2 and Pacific type. In the modified designs the extensions are eliminated. The use of the ordinary piston rod with a piston having an extended wearing shoe is considered good practice and is rapidly supplanting the use of the extended rod. Hollow bored extended rods of the Pennsylvania type could be used with almost as much saving in weight.

DISCUSSION

A number of members took part in the discussion. Marked advantages of the alloy and special steels in making it possible to reduce the weight of the parts, and thus the dynamic augment, were not questioned. James Partington, estimating engineer, American Locomotive Company, stated, however, that the use of these steels was not progressing as rapidly as the advantages seemed to warrant, because of the commercial and manufacturing conditions which confront the railways and the locomotive manufacturers. A number of months is now required for the delivery of the special heat-treated parts and, even under normal conditions, a much longer time is required than for carbon steel forgings. This is a bad handicap when it is necessary to replace forgings,

because of defects, in the erecting shop or in making regular running repairs. Mr. Strong, in replying to this criticism, suggested that the automobile manufacturers were using the alloy steels to the greatest possible advantage and that the difficulty in question could be overcome if the railroads would carry extra parts in stock.

W. E. Symons called special attention to the advantages of the four-cylinder compound locomotives in reducing the dynamic augment to a minimum. J. J. Yates, bridge engineer, Central of New Jersey, commented on the disastrous effect of an excessive dynamic augment upon the bridges and said that heavier wheel loads would be permissible in the proportion to which the dynamic augment could be reduced. The discussion also developed the fact that the high speed locomotives could be fairly well balanced but that the slow speed heavy freight engines were unbalanced to a very considerable degree because of the small diameter wheel and the fact that an adequate amount of counterbalance could not be provided. The use of the lighter parts would, of course, prove a very distinct advantage in such cases.

AIR SUPPLY TO THE LOCOMOTIVE FIRE BOX

The burning of fuel is a chemical combination of carbon and hydrogen in the fuel with oxygen of the air. There can be no combustion without oxygen. Air is as necessary as fuel for the production of heat.

It is an easy matter to calculate the theoretical amount of oxygen or air required for the complete combustion of a fuel; but it is extremely difficult, if not impossible, to secure complete combustion with the calculated amount of air.

Insufficient air causes heat losses from incomplete combustion. Too much air causes heat losses in front end gases. Bituminous coal requires from 11 to 12 lb. of air per pound of coal for theoretical combustion. A saturated engine with 200 lb. boiler pressure, burning high volatile coal containing 14,000 B. t. u. per pound, will have an unavoidable front end heat loss of 11½ per cent, when 12 lb. of air is supplied per pound of coal burned. With an air supply of 16 lb. the unavoidable front end heat loss is 14 per cent.

There is an increase of 2½ per cent in front end heat loss, due to increasing the air supply from 12 to 16 lb., but this is more than offset by a reduction of from 10 to 15 per cent in the heat losses due to incomplete combustion.

Perfect combustion cannot be approximated in the average locomotive firebox with an air supply of less than 16 lb., and this amount is not sufficient if the rate of combustion is high and the firebox is not provided with a brick arch and combustion chamber. Combustion takes place only when the combustibles are brought into intimate contact with oxygen. They must be thoroughly mixed and given time to burn—particularly the volatile combustible matter that burns above the fuel bed. In addition, combustion chamber space sufficient to allow the flames to burn out before striking the flue sheet must be provided.

If no mixing device (such as the arch) is used, more air is required than otherwise. Restricted combustion chamber space and short flueway also call for an increased air supply, if the volatile matter is to be completely burned.

The best design of firebox, equipped with a brick arch and combustion chamber requires at least 16 lb. of air per pound of coal at moderate rates of combustion when burning a high volatile coal. A poorly designed firebox will require more.

It is considered good practice to provide grates with air openings equal to 33 per cent. of the grate area and ashpan openings of 14 per cent. With good run-of-mine coal and light and level firing, an air supply of from 22 lb. at low rates of combustion to 10 lb. at high rates can be se-

cured. Usually air openings of 50 per cent through grates and 20 per cent through ashpans are not too large.

The fuel bed offers sufficient resistance to prevent excessive amounts of air being drawn into the firebox. It is not necessary to throttle the air at ashpan openings or grates and thereby put unnecessary work on the draft-producing apparatus.

Insufficient air causes large heat losses, smoke, low firebox temperatures, clinkers, honeycomb, delays and engine failures. Too much air, at worst, causes increased front end losses.

Engine failures from "too much air in firebox" have not yet come into fashion.—*J. T. Anthony in the Erie Railroad Magazine.*

RESPONSIBILITIES OF RAILROAD MEN*

BY ROBERT QUAYLE

General Superintendent of Motive Power, Chicago & North Western

"There is a great responsibility attached to railroad men today. I sometimes think that we should stop occasionally and consider what our responsibilities are. What can we do that will make for greater efficiency, that will make for success? What will allow us to reduce the man power in our shops, to do work with less men? The man who does this now, will be the man who will stand in the forefront, because he is doing something worth while. When you have a job that you must do you respond to the call and do it. We have a big task now: let us be on the job all the time, so that we can make good at it. We are at war, let me emphasize it, we are at war, and we are just beginning to realize it. We are expecting a great deal of the railroads, but we are not going to expect too much, because railroad men are thoroughly loyal, thoroughly efficient, and will measure up to what is demanded of them. One thing you must do now and that is your level best. This is no time for pessimism, this is a time for optimism. We must cheer everyone with whom we come in contact.

"We must be loyal and give men here and there, even though we are having a hard time. Let us do our part to back up our men, that the stars and stripes may shine with more glory than ever before. Let us do our work with clean hands. Democracy must prevail—democracy will prevail! Let us as a nation do something to lift the world out of the depths it is in, that the world may rise up and call us blessed. But let us not forget those who are close to us. The men in your shops need more than knocking. It has been said that you can't saw wood with a hammer. It is just as certain that you can't lift men with a hammer. We are going to do our part if we help those about us; we are going to do our part by doing our work cheaper and better than ever before. And when the country asks more of us we are going to take another notch in our belt, and march forward, and do the best we can.

"I want to say a word about the standard locomotives. I was a member of the committee of nine that was called on to prepare these designs. It was a big job to reconcile every member of the committee to each particular thing that was adopted. All the roads represented had their own standards, and they were all different. Many had to give up the fancy notions they cherished and had to take up notions of someone else, in order that the committee might agree. As a member I want to say that each man on that committee did his job splendidly. We saw that we could not bring in localism or sectionalism; what we did had to be for the good of the nation. It was essential that we get together and do what we could to help out. It is such sacrifice that brings results, and when men are ready to give up in order that democracy may prevail, we will get results."

*From an address before the Western Railway Club.



TABULAR METHOD FOR CALCULATING MOMENT OF INERTIA

BY WENDEL J. MEYER

The following method for calculating moment of inertia has several advantages; the component calculations are recorded and may be checked at any time; the method easily lends itself to the use of the slide rule; if the section be changed after a calculation is made, it is not necessary to make an entire new one; deductions for rivet holes are easily made.

The moment of inertia (I_b) of a compound section about any axis or base line is equal to the sum of the moments of inertia (I) of the component parts about axes through their own centers of gravity plus the areas (A) of the component

fiber of the section. By multiplying the areas (A) by the arms (d), the moments (M) of the areas about the base line are obtained and placed in the fourth column. A second multiplication by the arms (d) gives the quantities Ad^2 which are placed in the sixth column. The distance ($C = 10.55$) from the neutral axis of the section to the base line

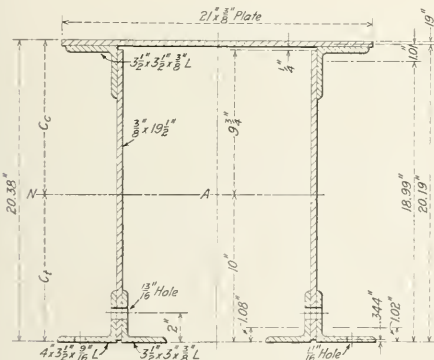

Section Used as Basis for Calculations

parts multiplied by the squares of the distances (d) from their own centers of gravity to the base line, or

$$I_b = I + A d^2$$

and

$$I = I_b - A d^2$$

Applying the latter equation to the compound section as a whole, there results:

$$I_b = I_c = A_c C^2$$

where I_b is the moment of inertia of the compound section about its neutral axis, A_c is its total area and C is the distance from its neutral axis to the base line.

The accompanying table shows the method applied to a center sill section. Since the section is symmetrical about its vertical center line, it is only necessary to work with half the section and then double the final result.

The sizes, areas (A) and moments of inertia (I) of the component parts of the section are placed in the first, second and last columns, respectively. In the third and fifth columns are placed the arms or distances (d) from the centers of gravity of the component parts to some convenient base line, which usually will be a line through the top or bottom

ORIGINAL SECTION SHOWN IN THE DRAWING						
Size.	Area.	Arm.	Moment.	Arm.	Area x (Arm.) ²	Mom.
In.	Sq. In.	In.	In.	In.	In.	In.
10.5 x .375.....	3.94	20.19	79.55	20.19	1606.1
3 1/2 x 3/2 x 3/8... 2.48	18.99	47.10	18.99	47.10	894.4	2.9
19.5 x .375.....	7.31	10.00	73.10	10.00	731.0	332.7
4 x 3 1/2 x 9/16... 3.90	1.02	3.98	1.02	4.1	4.2	4.2
3 1/2 x 3 x 3/8.... 2.30	1.08	2.48	1.08	2.7	2.7	2.7
Totals	19.93	(10.35)	206.21	3238.3	242.5
					3238.3
					206.21 x 10.35	3480.8
					1346.5

$$C_t = 206.21 \div 19.93 = 10.35; C_b = 20.38 - 10.35 = 10.03$$

$$Area = A = 19.93 \times 2 = 39.86 \text{ sq. in.}$$

$$Mom. of Inertia = I = 1346.5 \times 2 = 2693.0 \text{ in.}$$

$$Sec. Mod. (Top) = Z_t = 2693.0 \div 10.03 = 268.5 \text{ in.}$$

$$Sec. Mod. (Bott.) = Z_b = 2693.0 \div 10.35 = 260.2 \text{ in.}$$

With 3 1/2 in. x 3 in. x 9/16 in. Angle Instead of 3 1/2 in. x 3 in. x 3/8 in.

Size.	Area.	Arm.	Moment.	Arm.	Area x (Arm.) ²	Mom.
In.	Sq. In.	In.	In.	In.	In.	In.
Totals	19.93	10.33	206.21	3238.3	242.5
3 1/2 x 3 x 3/8.... 2.30	1.08	2.48	1.08	2.7	2.7	2.7
Differences	17.63	203.73	3235.6	139.8
3 1/2 x 3 x 9/16... 3.34	1.15	3.84	1.15	4.4	3.8	3.8
Totals	20.97	(9.90)	207.57	3240.0	243.6
					3340.0
					207.57 x 9.90	2054.9
					1428.7

$$C_t = 207.57 \div 20.97 = 9.90; C_b = 20.38 - 9.90 = 10.48$$

$$A = 20.97 \times 2 = 41.94 \text{ sq. in.}$$

$$I = 1428.7 \times 2 = 2857.4 \text{ in.}$$

$$Z_t = 2857.4 \div 10.48 = 272.6 \text{ in.}$$

$$Z_b = 2857.4 \div 9.90 = 288.6 \text{ in.}$$

With 3 1/2 in. x 3 in. 9/16 in. Angle but with Rivet Holes Deducted

Size.	Area.	Arm.	Moment.	Arm.	Area x (Arm.) ²	Mom.
In.	Sq. In.	In.	In.	In.	In.	In.
13/16 x 1 1/2.....	1.219	2.00	2.438	2.00	4.88
11/16 x 9/16....	.387	.344	.133	.344	.05
Total for holes	1.606	2.571	4.93
Totals	20.97	9.90	207.57	3240.0	243.6
Total for holes....	1.61	2.57	4.9
Net totals.....	19.36	(10.59)	205.00	3235.1	243.6
					3478.7
					205.0 x 10.59	2171.0
					3235.1
					1307.7

$$C_t = 205.0 \div 19.36 = 10.59; C_b = 20.38 - 10.59 = 9.79$$

$$A = 19.36 \times 2 = 38.72 \text{ sq. in.}$$

$$I = 1307.7 \times 2 = 2615.4 \text{ in.}$$

$$Z_t = 2615.4 \div 9.79 = 267.2 \text{ in.}$$

$$Z_b = 2615.4 \div 10.59 = 247.0 \text{ in.}$$

is obtained by dividing the sum of the areas ($A_t = 19.93$) into the sum of the moments ($M_t = 206.21$). The moment of inertia ($I_b = 3480.8$) of the section about the base line is given by the sum ($\Sigma Ad^2 = 3238.3$) of the sixth column

plus the sum ($\Sigma I = 242.5$) of the last column. Subtracting the quantity $A \cdot C^2 = M \cdot C = 206.21 \times 10.35 = 2134.3$ from I , the moment of inertia ($I_{na} = 1346.5$) of the section about its neutral axis is obtained. Doubling the latter, the result for the whole section is $I_{na} = 2693.0$, from which all other properties of the section may be found.

If the section be changed, repeat the quantities A , M , $\Sigma A d^2$ and ΣI from the first calculation, subtract the quantities for the component part which is to be changed, add them for the new part and proceed as before. The deduction for rivet holes is made in the same manner by treating the rivet holes as negative areas.

HOPPER CARS BUILT BY E. J. & E.

Side Dump Type without Continuous Center Sill, Floor Members Designed to Take Buffing Stresses

THE Elgin, Joliet & Eastern is building in its shops at Joliet, Ill., 500 steel hopper cars. These cars are of the side-dumping type and have a rated capacity of 140,000 lb. and a cubical capacity of 2,533 cu. ft. The length over the end sills is 41 ft., the maximum width is 9 ft. 10 $\frac{3}{4}$ in. and the maximum height of the car body is 11 ft. The average weight is 57,500 lb.

One of the unusual features in the design of these cars is the method in which the floor members are made to serve as a part of the underframe. The center sills are made up of two 15-in. 40-lb. channels tied together at several points. They are not continuous from end to end, but extend only

The main floor is made up of 5 16-in. floor plates fastened to numerous transverse A-frames built up of angle bars. Along the lower edge of the floor on each side is a 3-in. by 4-in. angle and at the top ridge there is fastened a 4-in. by 4-in. 18.5-lb. 100-deg. angle. This angle extends to the bolster, while the main floor and sloping end are jointed about 2-ft. from the bolster. The end of the top angle is attached to two bent plates with angles at the lower ends, these angles being riveted to the upper flanges of the center sills. The main floor member is further stiffened by the runaway, which is a 7-in. channel, fastened to the floor by numerous pressed steel supports. There are three openings in the floor on



Elgin, Joliet & Eastern Hopper Car

a short distance beyond the ends of the hopper openings. The ends toward the center of the car are cut at an angle approximately the same as the slope of the floor at the ends. Each of the four channels is 12 ft. 5 9/16 in. long. At the center plate the sills pass through bolsters made up of two plates stiffened with angles and Z-bars. The end sill is built up of a 12-in. channel and pressed steel shapes. The side sills are made of 12-in. 20.5-lb. channels and extend from the end sills a short distance beyond the bolsters. The center sill channels are fastened at the inner ends to three transverse members, a 3-in. by 3-in. angle at the extreme end, a 9-in. 20-lb. channel and a 6-in. by 6-in. angle opposite the ends of the hopper doors. These members serve to transfer the stresses from the center sills to the floor members.

each side to allow the links of the door mechanism to pass through. At each of these points the floor is stiffened with angles and the plates which form the openings for the door arms are used to support gusset web plates, which serve to stiffen the sides.

The sides are designed as girders and arranged to assist in transferring the weight of the lading to the bolsters. The top chord member is a bulb angle 4 in. by 3 in., weighing 11.9 lb. per foot, and the lower chord member is a 4-in. by 3-in. angle. The stiffeners opposite the gusset plates are cross-tie sections weighing 9.5 lb. per foot. At the ends of each bolster the sides are supported by two 2 $\frac{1}{2}$ -in. by 3-in. angles.

The side plates are $\frac{1}{4}$ in. thick, while the floor plates have

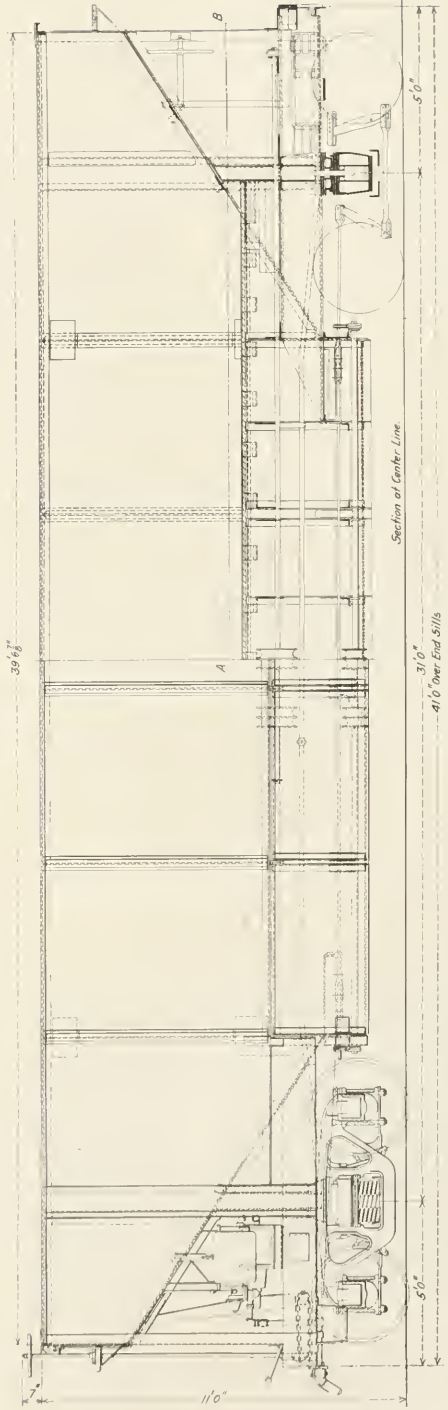
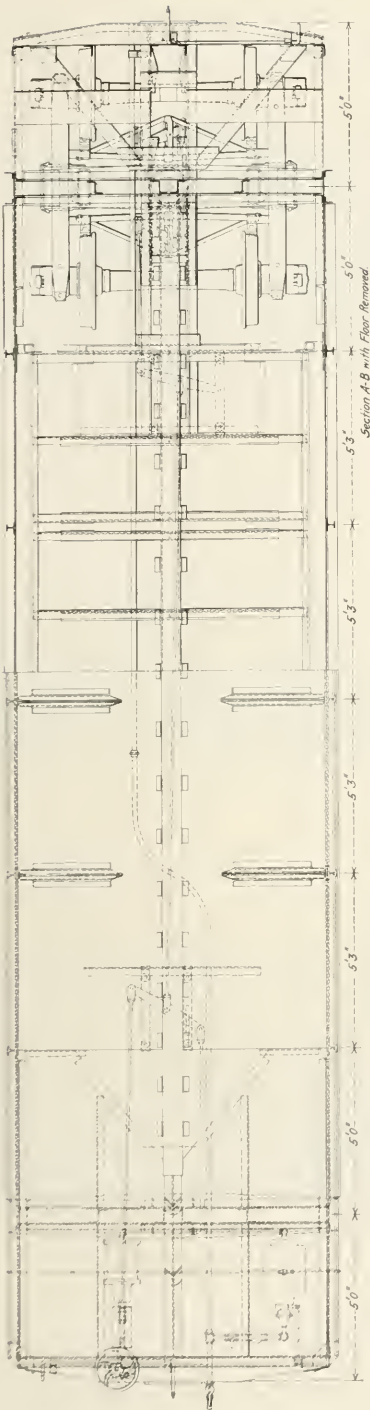

Plan and Elevation of E. J. & E. Hopper Cars

a thickness of 5/16 in. It has been found that the life of the floor and sides is about equal when these thicknesses are used. The sloping end floor sheet extends from the hop-

in the floor. The links are connected to arms on shafts carried under the sides of the floor. The links are bent so that they have a toggle action, and are self-locking when the doors are in the closed position. The shafts which control the operation of the doors are attached to the main operating

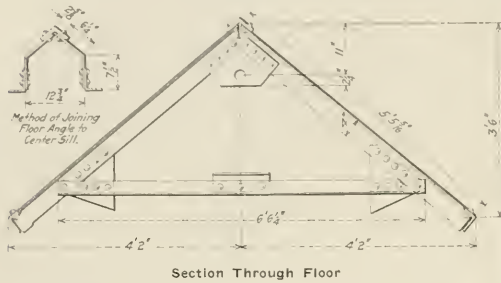

Fig. 2—Main Floor Member Being Assembled. Note Extension at End for Attachment to Center Sills

per up over the bolster to the end of the car, and is supported by angle irons. The vertical end plate is supported by four pressed steel end posts, in addition to the angle iron corner

shaft by chains. Two turnbuckles are placed in each chain to allow the position of the shaft to be adjusted so that both doors will close together. The main operating shaft extends under the floor to the end of the car, and is controlled

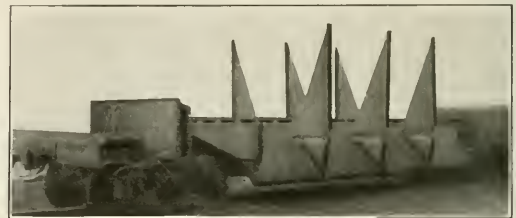
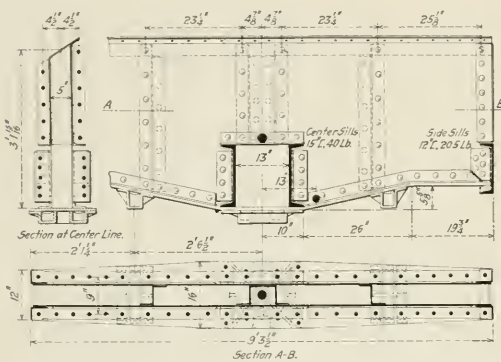

Fig. 3—Ends and Floor Section Assembled and Side Gusset Straps in Place

posts. The end sheet is stiffened at the top by a bulb angle of the same section as that used on the sides.

by a hand wheel and chain attached to an arm on the end of the shaft. The arrangement of the dumping mechanism is clearly shown in one of the illustrations.

The dump doors are 20 ft. 11 1/2 in. long and 2 ft. 10 1/2 in. in height. They are stiffened by angles along the top and

The trucks used under these cars have Andrews cast steel

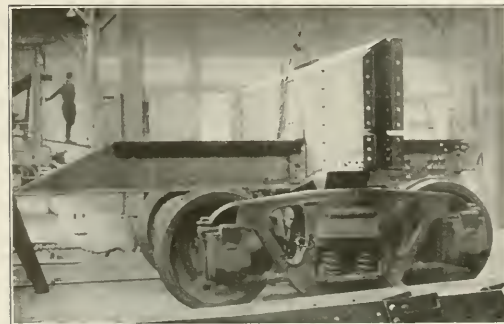

Fig. 1—Center Sills and Bolster Assembled and Placed on Truck bottom, and at the points where the operating mechanism is attached. There are five links attached to each door, two at the ends, which pass outside the hopper opening and three at intermediate points, which pass through openings

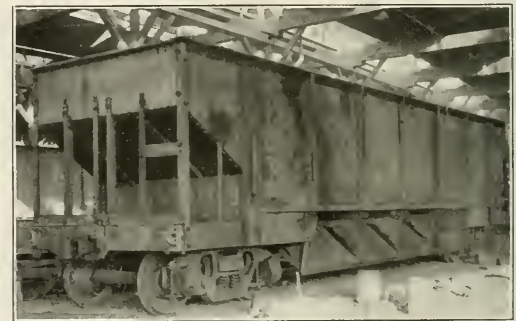

Fig. 4—Sides and Ends in Place Ready for Application of Doors and Appliances

side frames, rolled steel wheels, and Simplex truck bolsters. Ajax brake beams conforming with the M.C.B. specifications for No. 3 beams are used. A brake rigging safety hanger similar to the type previously described in the *Railway Mechanical Engineer** is also used on these cars. In

*See issue of August, 1917, page 448.

the present design, however, an additional feature has been incorporated in this device. A portion of the upper end of the hanger is bent down horizontal, so that it extends over the compression member of the brake beam and serves to pre-

venting the work of construction are novel and interesting. Practically all the building is done on a single track, which passes through the repair shed. This track has been fitted up especially for building cars. The trucks are assembled at

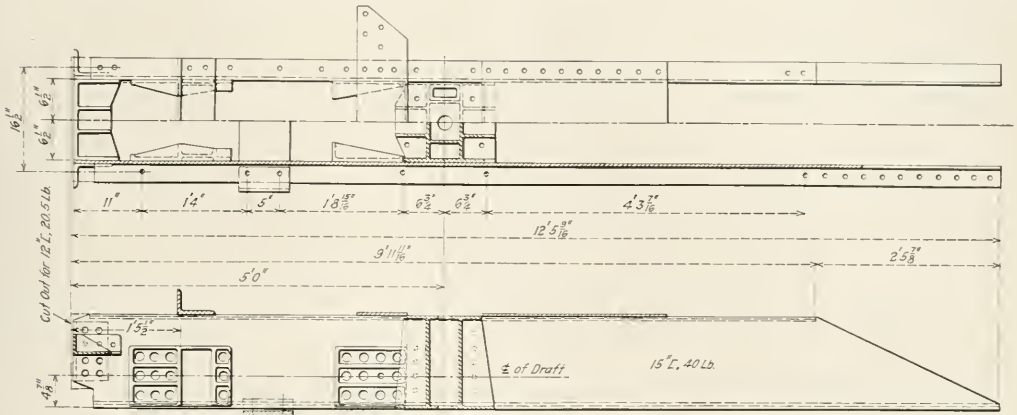

Short Center Sills Used in E. J. & E. Hopper Car

vent the beam from tipping. An extension is provided under the spring plank to prevent the hanger from being raised. The new design is clearly shown in one of the illustrations.

The couplers used on these cars are the M.C.B. type D, No. 5, with 6-in. by 8-in. shank and 9 1/8-in. butt, attached to the yoke with a key. The yoke is of 1 1/4-in. by 5-in.

one end and, as they are required, are rolled to the point where the cars are erected. The smaller parts, such as the plates, gussets, angles, center sill channels, etc., are prepared in the steel shop. Many of the methods used in this department have already been described in these columns.* The finished parts are stored until needed and are carried to the

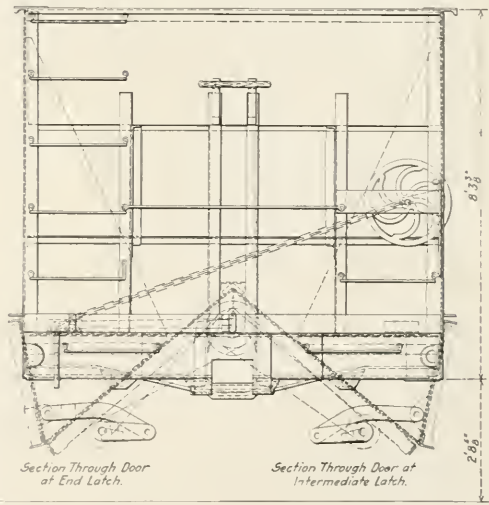
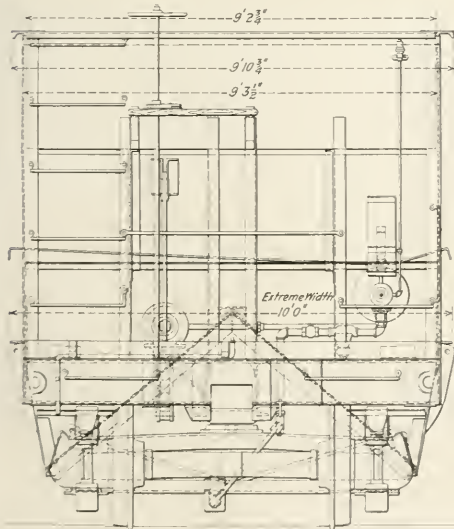

Plan and Elevation of E. J. & E. Hopper Cars

wrought steel. The draft gear is the Miner type A-18; Westinghouse air brakes are used with K-2 triple valve, and a 10-in. by 12-in. air cylinder.

METHODS USED IN BUILDING THE CARS

These cars are being built in the company's shops at Joliet at the rate of 100 cars a month. The methods used in han-

erecting shop on hand cars. A narrow gage track adjacent to the erecting track is used only for the delivery of material.

When starting the work on a car two trucks are first rolled into position, the space left between them being somewhat greater than the length of a car. The material for the

*See Railway Mechanical Engineer, issue of October, 1917, page 563.

center sills and bolsters is placed next the trucks, with the parts for the main floor members between. The two center sill channels, bolster, side bearings and center plate are assembled on horses. When completed these units are raised by a chain hoist and lowered onto the trucks as shown in Fig. 1.

The A-frames for the floor members are bolted to the angles extending along the side of the floor and the floor sheets, dump arm covers, and top angles are riveted into place (see Fig. 2). The floor section is then raised by chain hoists,

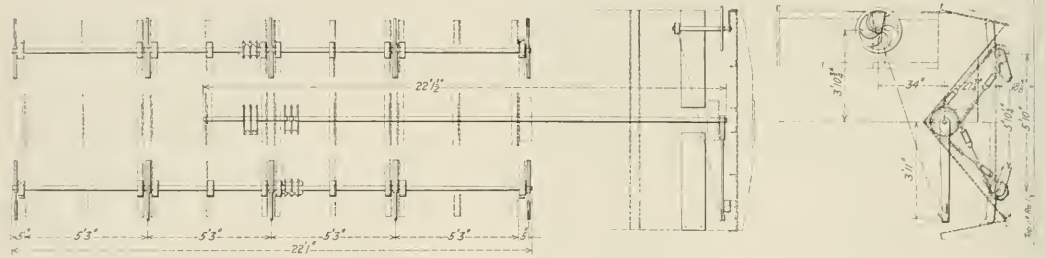

Arrangement of Door Operating Mechanism for the Elgin, Joliet & Eastern Hopper Cars

the center sills and bolsters are rolled into place and riveted to the floor members. The end sills, couplers and side gusset plates are next applied as shown in Fig. 3, and the sloping ends of the floor are put in place.

The sides are assembled on horses, together with the side sills. When finished they are hoisted by chain blocks suspended from trolleys running along both sides of the track. The partly finished car is run down the track between the sides, and they are hoisted to position and riveted in place. The ends are then applied and the car is ready to be run to another track for the application of the hopper doors, door-operating mechanism, brake rigging, etc. Although only one track is used for the main erecting operations, no difficulty has been experienced in keeping up an average output of five cars per day.

SHOULD THE MASTER CAR BUILDER'S REPAIR CARD BE ABOLISHED DURING THE PERIOD OF THE WAR

BY E. A. SWEeley
Master Car Builder, Seaboard Air Line

It has been suggested by various mechanical and operating officers that during the period of federal control of the railroads, the M. C. B. code of interchange rules be suspended and used merely as a reference as to what defects or conditions constitute a menace to safe operation and that charges for repairs to equipment, which under the individual ownership were considered foreign, be discontinued.

The suggestion is one that is worthy of consideration by all operating officers, and to carry it out successfully a plan must be devised whereby it would be found practicable to discontinue the "swapping" of repair cards and still keep alive the spirit of M. C. B. rule No. 1, which reads as follows: "Each railroad company must give to foreign cars while on its line, the same care as to inspection, oiling, adjusting and repairs, that it gives to its own cars."

In recommending the abolition of the M. C. B. repair charges, some thought must be given to the repairs which it will be necessary to make to cars of private lines and short lines, which are not under government control, and the equipment of Canadian and Mexican Railroad companies. A portion of the equipment handled will be in this class and the handling of this equipment will necessitate repairs

and an M. C. B. billing force will still be required.

The writer has given this matter consideration and would be in favor of the abolition of charges for repairs, if an equitable substitute were offered whereby the spirit of M. C. B. Rule No. 1 could be kept alive, but cannot become reconciled to the fact as it appears, that by removing the charges for repairs to the "other fellow's equipment," it must follow that the incentive to maintain care as required by M. C. B. Rule No. 1, is removed.

Under Government control, practically all of the railroads

are being operated as a unit. The principal object of the railroad officers is to help win the war, but at the same time the fact remains that the railroads are private property, borrowed by the government to help win the war, and there is no doubt that it is the intention of the government to return this property to the owners in at least as good condition as when borrowed. This, it is believed, will not be the case, if the charges for repairs are eliminated.

It would appear to the writer, after studying this matter from every angle, that it would not be to the best interest of the railroads, or of the government itself, to eliminate the charges for repairs to freight cars, other than those owned by the road making the repairs.

As all of the discussions which have thus far been held in regard to the elimination of charges for repairs to freight cars were made with the end in view that man power be conserved and expenditures cut down, the thought has offered itself that the most practical solution to this problem would be to establish regional billing departments, having a number of such departments to act as clearing houses in convenient locations in different parts of the country and have the repair cards for all railroads sent to the various clearing houses. The repair bills could be made up monthly as they are now handled in the auditing departments of the several railroads and an annual adjustment of the repair bills between the several railroads could be made.

This plan would divert to other fields of occupation, many men and women who are now engaged in preparing M. C. B. bills, checking cars, auditing bills and preparing vouchers. In addition to this a large amount of stationery would be saved annually and the spirit of M. C. B. rule No. 1 would be preserved intact.

WAKE UP!—Thus far we are certain, the Germans haven't invented any long range gun that will carry across the Atlantic. But it would require such a gun to awaken some Americans to the realization that we are in this war—*Utica Herald-Dispatch*.

BRITISH AMBULANCE TRAINS FOR THE U. S. ARMY.—The Great Western of England has supplied 104 locomotives and over 4,000 cars for the railways overseas. It is building two ambulance trains for the United States troops in Europe. Altogether fifteen such trains are being, or have been built by British railways.—*The Engineer, London*.

STANDARD STEEL SHEATHED BOX CAR

Specifications and Designs Similar to Other Box Cars, Wood Lining Provided on Sides and Ends

THE Railroad Administration issued early in April specifications and drawings for a 50-ton steel frame, steel sheathed box car having an estimated weight of 46,000 lb. Since that time, however, representatives of the War Industries Board, the Shipping Board and the Railroad Administration, meeting in joint conference, decided that the Shipping Board, the Army and the Navy will have priority over the railroads in their requirements for steel.

mentioned above. This car is to be carried on the standard 50-ton truck and has the following general dimensions:

Length inside	40 ft. 7 $\frac{3}{4}$ in.
Width inside*	8 ft. 6 in.
Height inside*	9 ft. 0 in.
Length over striking plate*	42 ft. 1 $\frac{1}{2}$ in.
Width over roof sheets	8 ft. 3 $\frac{1}{2}$ in.
Width over side plates	9 ft. 4 in.
Width over all	10 ft. 0 in.
Height from rail to top of car at eaves	12 ft. 9 in.
Height from rail to top of brake mast	14 ft. 2 $\frac{1}{2}$ in.
Height from rail to top of running board	13 ft. 7 $\frac{1}{2}$ in.
Distance center to center of trucks	31 ft. 1 $\frac{1}{2}$ in.
Height from rail to center of coupler	2 ft. 10 $\frac{1}{2}$ in.
Height from rail to bottom of center sill	2 ft. 4 $\frac{1}{2}$ in.
Estimated weight	46,000 lb.

*These dimensions are common to the other box cars.

Underframe.—The underframe is very similar to that used for the single sheathed box car, having 12-in. channel center sills with a 20 $\frac{1}{2}$ -in. by 1 $\frac{1}{4}$ -in. cover plate, 9-in. channel side sills, 1 $\frac{1}{4}$ -in. pressed steel floor supports, pressed steel diaphragm bolsters and 5 16-in. pressed steel corner braces. The crossbearers are the same, with the exception of the cover plates, which are slightly heavier for these cars. The end sills are 6-in. by 4-in. by 3 $\frac{3}{8}$ -in. angles, on the outside of which is riveted the steel end. The draft sills are practically identical with those of the other box cars, the only change being in unimportant details made necessary for supporting the steel sheathing of the car. On account of the similarity in the designs of the underframes a reproduction of the underframe for this car is not shown.

Superstructure.—The designs for this car call for a 1 $\frac{1}{2}$ -in. steel sheathing with a 1 $\frac{1}{2}$ 16-in. lining at the sides and ends, and a steel roof of 3/32-in. plates. The same designs of steel ends are permitted as for the other box cars. The side framing is well illustrated in the view showing the general plan of the car body. There are six pressed steel posts on each side of the car made from 1 $\frac{1}{4}$ -in. plate. These are 8 in. wide and 3 $\frac{1}{2}$ in. deep. In addition to these there are eight 3-in. by 3 $\frac{1}{2}$ -in. wooden side posts to which is nailed the inside lining. The end posts for the plain end construction, which are shown in one of the illustrations, are pressed from 1 $\frac{1}{4}$ -in. plate and are 7 $\frac{3}{4}$ in. wide by 3 $\frac{3}{4}$ in. deep. The corner posts are of wood. The side plates are 4-in., 10.3-lb. Z-bars, to which are riveted the side sheathing and the roof sheets. The end plate is a 5-in. by 3-in. by 5 16-in. angle.

There are two designs of roof permitted, that shown in

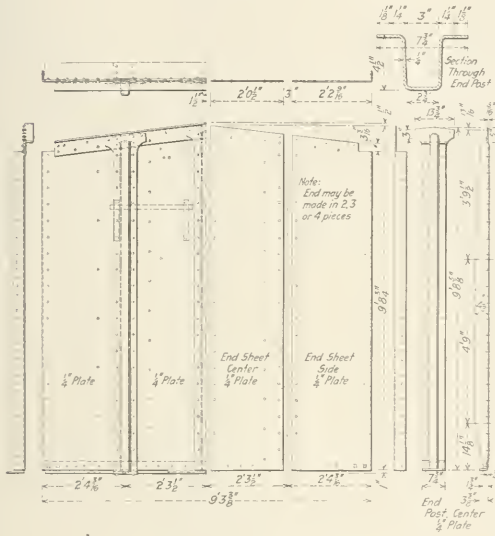

Plain Steel End for the Standard Steel Box Car

As a result the all-steel box cars, which are described below, will not be built at this time and less steel than was originally planned will be used in other types of cars.

The details of the steel-sheathed box cars are as nearly as possible the same as the other standard box cars, which were described on page 189 of the April issue. The under-

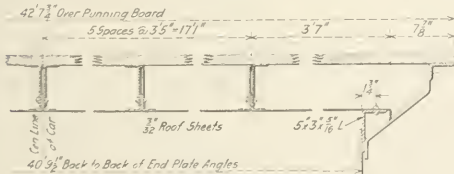

One Type of Roof Construction Permitted on the Steel Sheathed Box Car

frame is practically a duplicate of the single sheathed car, several of the door details are the same and the draft sill is the same with the exception of minor changes necessitated by the design of the car. The body specifications are the same as those for the box cars described in the article

the general plan and one shown in the roof section which has been reproduced. In both cases a 3/32-in. roof sheet is required. A pressed steel carline is used on the arrangement shown in the general plan and the running board is supported by angles bolted to a pressed angle curved to con-

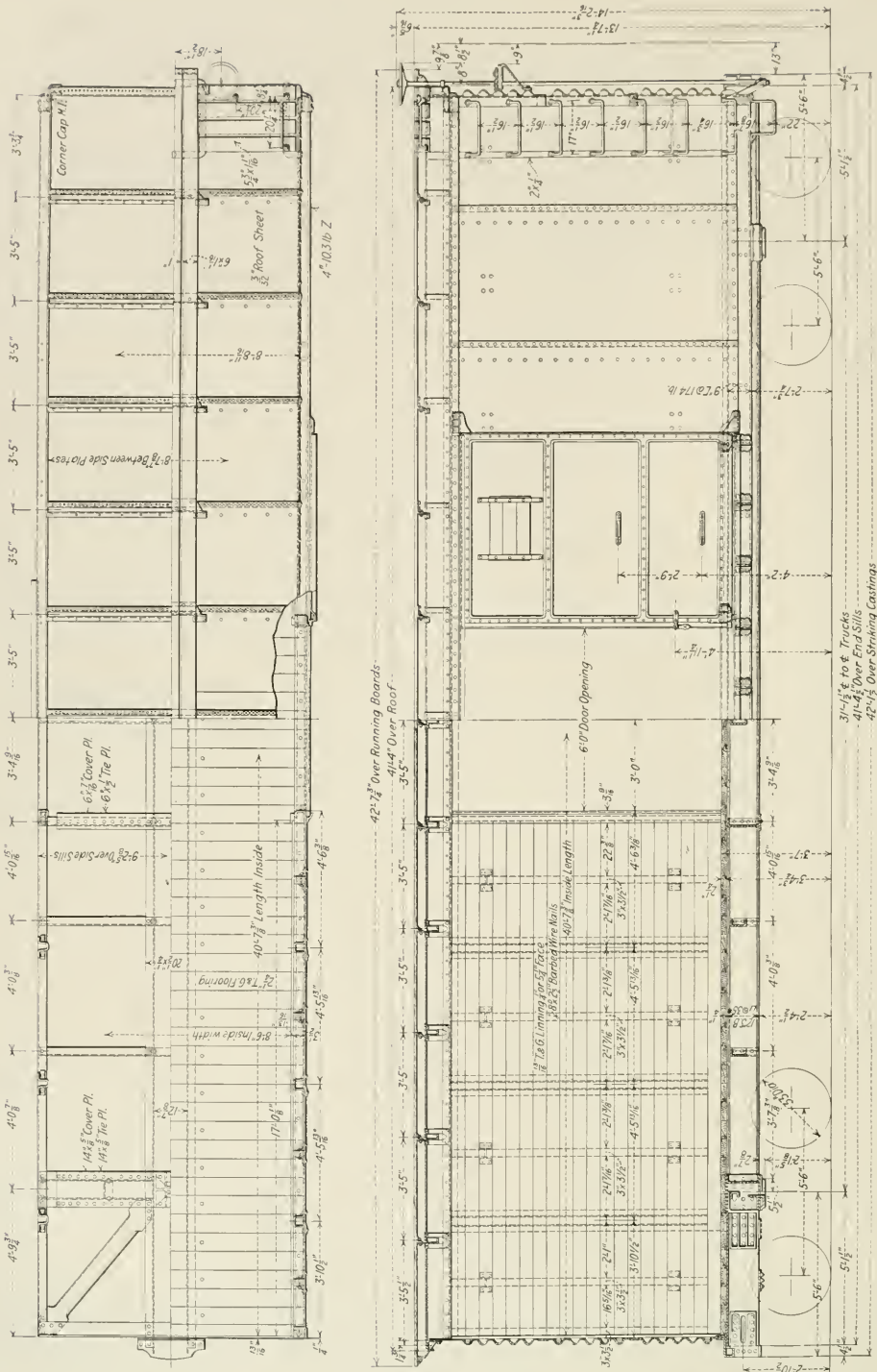

General Plan of the United States Standard Steel Sheathed Box Car

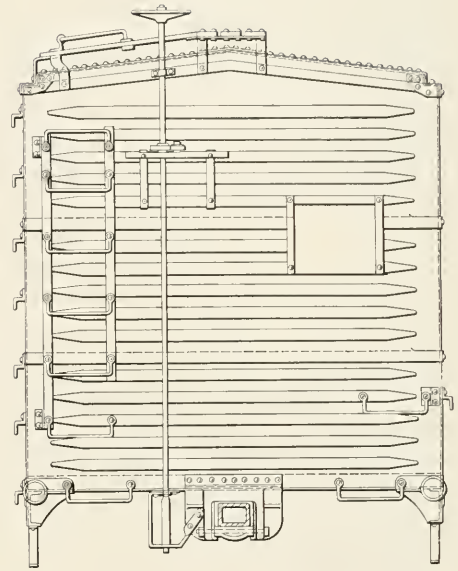
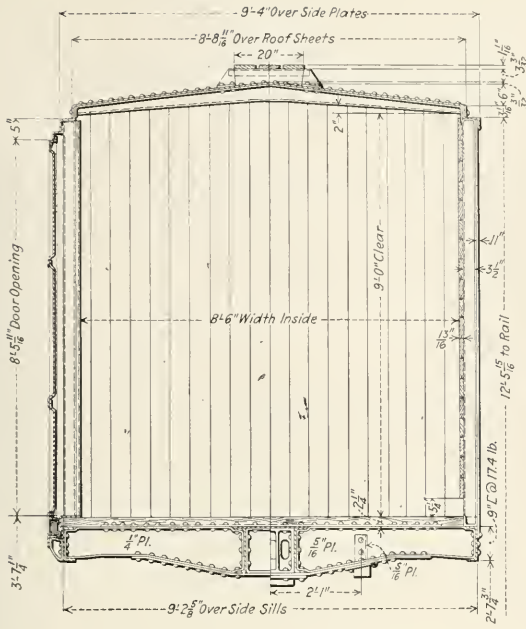

Section and End Views of the Standard Steel Box Car

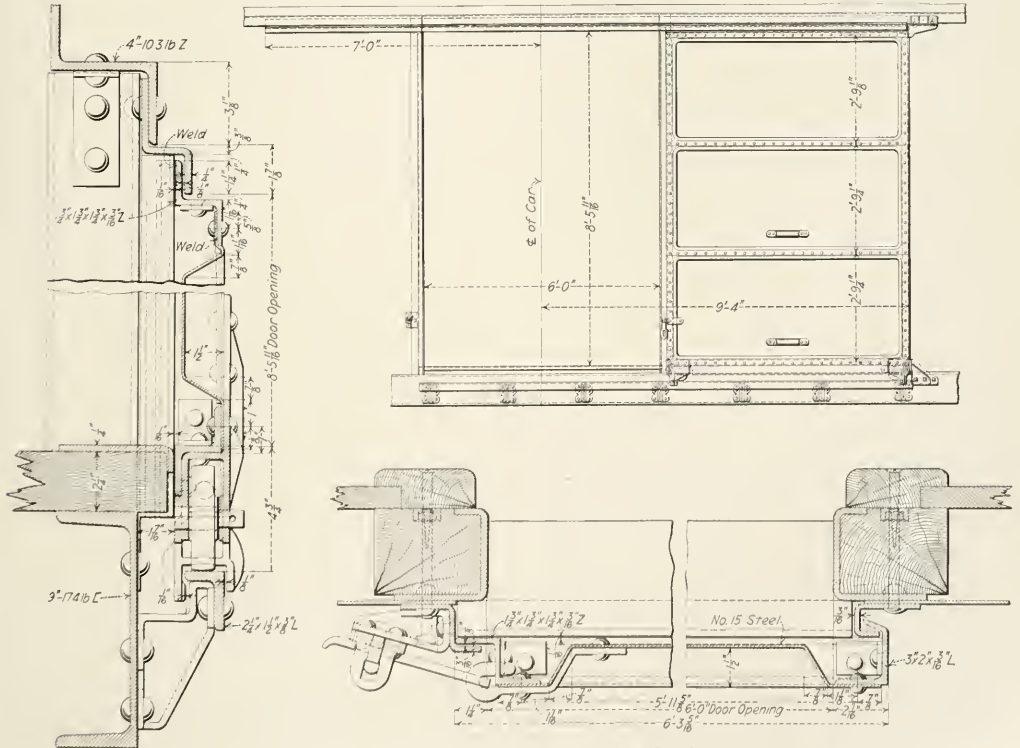

Steel Door for the United States Standard Steel Box Car

form to the contour of the roof. In the other plan the roof sheets are supported by outside carlines pressed from 5, 16-in. steel, which also support the running board.

An all-steel door of the underhung type is used, providing an opening 6 ft. wide by 8 ft. 5-11/16 in. high. This door is made up of three pieces of No. 15 gage steel, pressed as

indicated in the drawings. The door framing is made up of a 1-3/4-in. by 1-3/4-in. by 1-3/4-in. by 3/16 in. Z-bar at the front, top and bottom, and by a 3-in. by 2-in. by 3/16-in. angle at the back. The rollers are carried on a 2-1/4-in. by 1-1/2-in. by 3/8-in. angle. There are many of the details of the door common to the doors used on the other box cars.

FREIGHT CAR AND TENDER TRUCK BOLSTERS

An Explanation of the General Principles Involved in the Design, Loading and Testing of Truck Bolsters

BY G. S. CHILES AND R. G. KELLEY

PART II*

It will be recalled that the value of the section modulus as derived from the formula from which curve 8 of Fig. 3 was plotted was slightly less at the side bearing in all three examples of side bearing spacing and that it was considerably less toward the center of the bolster. At some points, as for example, in the region from 17 in. to 23 in. from the supports, in the case where the spread of the side bearings was assumed to be 50 inches, the section modulus as derived from the formula is greater than that which obtains from the use of the method which requires that the bolster be designed to carry either the entire load at the center plate or one-half of the load at the center plate and one-half at either side bearing. The fibre stress for this combined method of loading was limited to a value of 9,000 pounds per square inch as compared with 12,500 for the formula method. Varying the fibre stress of either method would alter the required section modulus but would not affect the general slope of the diagrams to any appreciable extent.

Having considered the loads reactions, bending moments, etc., incident to the design of bolsters along practically the same lines followed in the design of the M. C. B. axles, a study of Fig. 9 may bring out some points of interest. In this figure, diagrams 1 and 8 are the same as those shown in Fig. 3, the former being plotted for a center plate load of 73,000 lb. and an allowable fibre stress of 9,000 lb. per sq. in. and the latter for a center plate load of 73,000 lb. and an allowable fibre stress at the center of 12,500 lb. per sq. in. A curve similar to curve 8 may be formed by assuming a load of 73,000 lb. to act at the center plate and by reducing the 12,500 lb. fibre stress at the center and at the points of support, the stress approaches a limiting value which is only one-half the value at the center or 6,250 lb. per sq. in.

Diagrams 13, 14 and 15 of Fig. 9 are derived from the bending moment diagrams of the corresponding numbers plotted in Figs. 7 and 8. It will be remembered that the vertical load was increased 26 per cent in order to compensate for vertical oscillation and that a horizontal force equal in amount to 0.4 of this total load was assumed to act at a point 72 in. above the top of the rail. In plotting the section moduli diagrams for the bending moment diagrams 13, 14 and 15, it was decided to employ a fibre stress which would give a section modulus at the center of the bolster approximating that of formula 8 and it was found that a working fibre stress of 18,000 lb. per sq. in. would meet this requirement inasmuch as the resulting section modulus for diagrams 13, 14, 15 would be 123.8, 111.7 and 107.9 respectively, as compared to 112.4 derived from the formula used in plotting diagram 8. Those sections of

these diagrams which are included between the center line of the bolster and the points where they intersect diagram 1, are drawn in with broken lines in order to emphasize them and to bring out more clearly the contrast between them and diagram 1.

In case of the side bearings having a spread of 50 inches, the value of the section modulus at the side bearings would be 76.4 according to diagram 13, whereas it would be 65.0 according to the formula of diagram 8. For the 60-in. spacing, diagram 14 requires a section modulus of 45.4 as against 44.2 for diagram 8. For the 64-in. spacing the value of the section modulus according to diagram 15 is 34.1 while according to diagram 8 it becomes 34.7. Thus a bolster having a 50-in. side bearing spacing, designed in accordance with the formula employed in plotting diagram 8 and based upon a fibre stress of 12,500 lb. per sq. in., would be subjected to a fibre stress of 21,150 lb. per sq. in. at the side bearing under a loading such as that assumed in designing axles.

Similarly, the fibre stress at the side bearing would reach

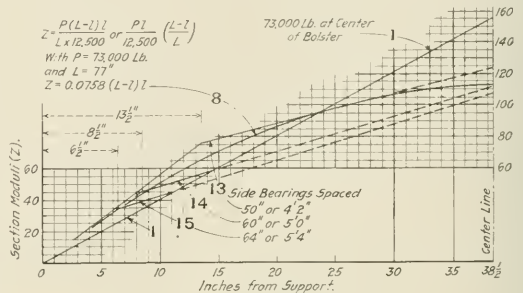

Fig. 9—Section Modulus Diagram

a value of 18,500 lb. in the case of the 60-in. side bearing spacing and a value of 17,650 lb. in the case of the 64-in. spacing. The design of M. C. B. standard axles is based upon a working fibre stress of 22,000 lb. per sq. in., but as it is questionable as to whether bolsters are ever subjected to any such loading in actual service as that assumed by the 1896 M. C. B. Axle Committee, it may be of interest to consider briefly the method of reasoning by which they reached their conclusions.

In the course of a series of experiments with four wheel cars on the Prussian State Railways, Wöhler ascertained that the weight on the journal was increased about 37.5 per cent by the forces set up by the vertical oscillations of the car, thus making the resulting maximum load 137.5 per cent of

*The first part of this article appeared in the April *Railway Mechanical Engineer*, and for greater convenience the figures are numbered consecutively from the beginning.

the normal weight. The M. C. B. Committee on axle design referred to above, endeavored to confirm Wöhler's results by experiments with the ordinary type of eight wheel cars in service on American Railways. A thirty-ton capacity box car, equipped with the Fox type of truck was selected and the total static or normal load carried at each axle above the springs was determined and found to be 23,588 pounds or 11,794 pounds per spring. The springs were calibrated, a recording mechanism which would register the maximum compression of the spring applied, and the car was then run over the Pennsylvania Railroad from Renova, Pa., to Canandaigua, N. Y., and return, a total distance of 398 miles. As the result of the observations made during this test run, it was found that the average maximum com-

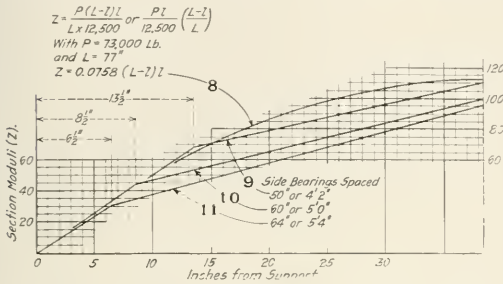

Fig. 10—Section Modulus Diagram Based on Bending Moments of Fig. 5

pression of the eight springs was 19,469 lb. or 167 per cent of the normal load and that the maximum compression for any one spring was 23,403 lb. or 198 per cent of the normal load.

The value of the horizontal force equal to 0.4 the vertical static load or center plate load, was found to be sufficient to almost entirely relieve the weight on one rail, i. e., to almost overturn the car. This value of the horizontal force was therefore accepted as the maximum value; the maximum calculated pressure on one spring due to the combined static load, and this assumed horizontal force is equal to 18,573 lb. The difference between this maximum calculated pressure of 18,573 lb. and the maximum compression of 23,403 lb. measured on one spring during the experimental trip, or 4,830 pounds, was regarded as being due to the vertical oscillation which is equal to 41 per cent of the static load on each spring. This would not necessarily be the actual vertical oscillation, but it was considered to be the value of the maximum vertical oscillation when the horizontal force was a maximum. The moments obtained by the above method (Reuleaux) provided for an axle larger in diameter in the center than the method wherein the load is assumed to be 198.4 per cent of the normal load, while the method which takes into consideration the action of a horizontal force equal in amount to 0.4 the vertical static load, provides for a larger diameter both at the wheel seat and also at the center of the axle, than would be the case, were all the registered spring load, less that due to the static load, considered as being due to vertical oscillation. Such would not be the case, as regards the bolster.

If all the registered spring load is assumed to be due to vertical oscillation, the resulting static load would be 198.4 per cent of the normal load and the bending moment at the center of the bolster would be 198.4 per cent of the normal moment. Assuming an allowance of 26 per cent of the static or center plate load for vertical oscillation and a horizontal force equal to 0.4 this value, as was the case in plotting diagrams 13, 14 and 15 of Figs. 7 and 8, the per cent of increase in the bending moment at the center of the

bolster, will be found to vary from 138 to 159 per cent of the normal bending moment. These values are tabulated in the third or lower line of Table II.

Table III is abstracted from a paper entitled "Some Experiments to Determine the Force on a Truck Side Frame and Stresses Produced by these Forces," which was delivered before the Railway Club of Pittsburgh, Feb. 22, 1915, by Professor Louis E. Endsley of the University of Pittsburgh.

In these tests, the truck springs of the Pennsylvania standard H-21 Hopper Car were calibrated and a record made of the maximum compression of the springs under each end of the bolster, this maximum pressure for each test is tabulated in column 5 of Table III. The maximum direct vertical pressure in per cent of the normal load, is recorded in column 6; these values being obtained by dividing the values of column 5 by those of column 4. It will be noted that this

TABLE III—RESULTS OF TESTS TO DETERMINE THE MAXIMUM VERTICAL PRESSURE COMING ON TRUCK SIDE FRAME

Test	Kind of service	Load on car	Normal load on truck side frame	Maximum pressure on side frame	Maximum load in per cent of normal
1	Local	None	8,175 lb.	16,400 lb.	200.
2	Local	None	8,175 lb.	15,800 lb.	193.
3	Local	66,000 lb.	24,675 lb.	52,800 lb.	214.
4	Local	66,000 lb.	24,675 lb.	45,600 lb.	182.
5	Through freight	91,000 lb.	30,925 lb.	66,600 lb.	216.
6	Through freight	91,000 lb.	30,925 lb.	76,000 lb.	246.
7	Through freight	91,000 lb.	30,925 lb.	60,100 lb.	194.

maximum load ranged from 182 per cent to 246 per cent of the normal.

In the course of three of the round trips between Pittsburgh and Alliance, the Standard M. C. B. springs which are designed to go solid at 64,000 lb. went solid several times during each trip of eighty (80) miles. The load on the truck side frame during these tests was 30,925 lb., so

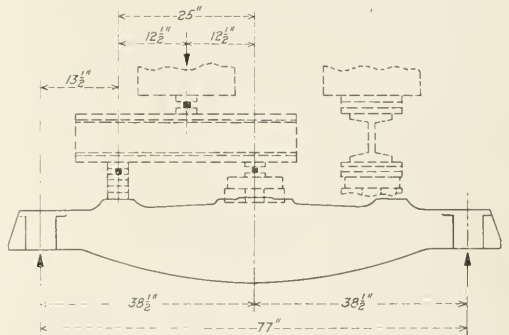

Fig. 11—Method of Loading Bolster for Test

that a force of over 207 per cent of the normal load was not uncommon. Four new sets of springs, having a capacity of 104,000 pounds were then substituted and the results obtained during three additional round trips are set down in the last three lines of Table 3, the data for the first four tests recorded in this table being obtained when the car was equipped with the 64,000 lb. capacity springs. Prof. Endsley called attention to the fact that the results indicated very clearly that the standard 100,000 lb. capacity M. C. B. springs do not have sufficient capacity, as the forces of over 70,000 lb. were not unusual with a normal load of 30,925 lb. on each frame.

As the maximum load exceeded 216 per cent of the normal load in one test only, being 246 per cent in test No. 6, Prof. Endsley concluded that a load equal to 220 per

cent of the normal load on the frame would be a conservative figure for the design of a freight car truck.

The maximum loads in per cent of the normal loads determined by the experiments conducted by Prof. Endsley, which are tabulated in column 6 of Table III, should be compared with the percentages given in Table I, since they both represent the reactions at the end of the bolster in terms of the normal load. For a vertical or center plate load of 73,000 lb. and a horizontal force equal to 0.4 of this load or 29,200 lb. assumed to act 46 in. above the center bearing, the maximum calculated reactions are 205 per cent, 209 per cent and 221 per cent of the normal reactions respectively, the greater value being that for the 50-in. side bearing spacing. As previously pointed out, in order to design a bolster, it is essential not only to know the maximum reaction to which it will be subjected, but also to know what per cent of this reaction will be due to vertical oscillation. If the reaction at each end of the bolster were recorded simultaneously, then it would be possible to determine the exact relation between the vertical oscillation and the horizontal force, both as regards the amount and also the time of action, but until such experimental data is obtained, it is necessary to assume some such relation. Since the system of loading which deals with a combination of center plate load of 73,000 lb. and a horizontal force equal to 0.4 of the center plate load or 29,000 lb., acting through an arm of 46 in., sets up reactions which approximate those of Prof. Endsley's experiments, we have, in view of this fact, constructed section modulus diagram, Fig. 10, which is the same general type as Fig. 9. In determining the section moduli, the values for the bending moments of Fig. 5

with a fibre stress of 14,000 lb. per sq. in., the section moduli at the center of the bolster were 120.3, 114.0 and 110.1 for the three side bearing spacings as compared to 112.4 by the formula in which a 12,500 lb. stress was used. The reaction for the bolster subjected to the combined action of a direct center plate load of 73,000 lb. and a horizontal force equal in amount to 0.4 of this load and whose side bearings have a spread of 50 in. is equal to 221 per cent of the normal reaction which is practically equivalent to the 220 per cent suggested by Prof. Endsley, and as it is our understanding that the side bearings on the hopper car used in the experiments conducted by Prof. Endsley were spaced 50 in. apart or the same as one of our assumed spacings, we have plotted the diagrams of Fig. 10, for a fibre stress of 16,000 lb. since the resulting values for the section moduli, for the bolsters having the same side bearing spacing, check with the formula shown in the upper

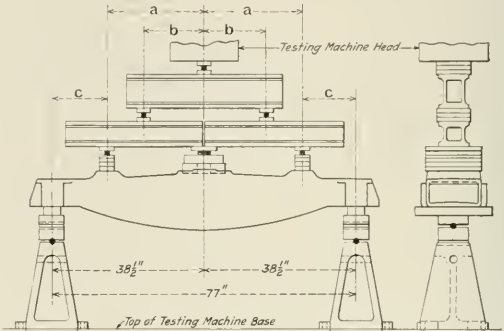

Fig. 13—Proposed Method of Testing Bolsters

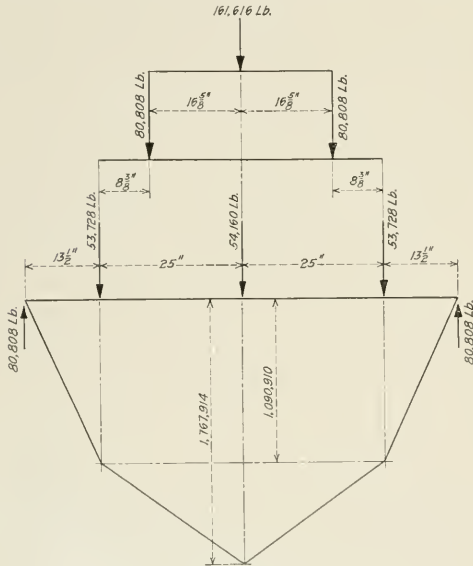

Fig. 12—Bending Moment Diagram Shown at 9, Fig. 5

part of the figure. Based upon a fibre stress of 16,000 lb. per sq. in., values for section moduli at the center of the bolster, as Fig. 5, are 110.5, 99.7 and 96.4, respectively, which of course, are slightly less than those for the 14,000 lb. fibre stress. At the side bearings for the 16,000 lb. stress, we obtain the values of 68.2, 40.4, and 30.4, as compared to 65.0, 44.2 and 34.8 by the formula method. The fact that these values approximate each other very closely at the side bearings, becomes more evident when the fibre stress is determined from the moments of Fig. 5 and the section moduli obtained from the formula, the stresses being 16,800, 14,650 and 14,000 respectively, for the 50-in., 60-in. and 64-in. spacing.

In purchasing truck bolsters, it is the practice of some railroad companies not to specify the method according to which the bolsters shall be designed but rather to require that the finished bolster shall undergo, in a satisfactory manner, certain tests commonly known as "design tests." Others require that the bolster be built according to a specified method of design as well as that the finished bolster meet certain specified tests, while others merely require that the bolsters be furnished in accordance with drawings submitted by the railroad company. Examples of the practice first mentioned are illustrated by the following sample specification.

DESIGN

"1.—On receipt of approved drawings for new designs the manufacturer will make a sufficient number of bolsters and truck sides for the purpose of making a design test. After the manufacturer has determined that samples are in accordance with drawings and that the design is satisfactory, he shall present not less than four additional samples for a final design test. The final design test is to be made upon a suitable testing machine at the manufactur-

were used and diagrams developed for the three side bearing spacings, the numbers 9, 10, 11 referring to the bending moment curves of Fig. 5 of the same number.

As was the case in constructing the diagrams of Fig. 9, which were based upon an assumed fibre stress which would provide for a section modulus at the center of the bolster approximating the same as that obtained by use of the formula used in plotting diagram 8, a fibre stress was assumed in order to plot 9, 10 and 11 of Fig. 10. It was found that

ers' works in the presence of the railroad representative.

"2.—The samples used in the final design test will not be so distorted that they cannot be shipped on order.

"3.—After a new design is once tested as provided for in paragraph No. 1 and the design found satisfactory, no additional design tests will be required unless the design is subsequently changed, revised or modified.

"4.—The test loads herein specified are applicable only to a normal design of truck bolster and truck side.

"5.—A normal design of truck bolster will have the following general dimensions: For a 50-ton capacity car the width over bolster at guides not less than 15 in., depth at center not less than 14 in. and depth at ends not less than 6 in.

"The 50-ton truck bolster to stand the following preliminary vertical test load, 80,000 lb. with a deflection of

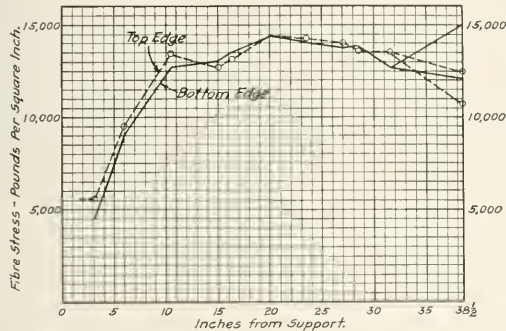

Fig. 14—Curves Showing Calculated Values of Bolster Stresses

not over 0.0625 in. For a 200,000 lb. load the deflection to be not over 0.20 in. and permanent set not to be over 0.0625 in.

"For the transverse strength the test loads to be one half of the vertical loads with the same deflection and set."

The above represents a type of specification quite generally followed in such instances and another specification reads as follows:

"For each 200 bolsters offered, two shall be selected at random, one to be used for vertical test and the other for transverse test of strength. If either test fails, the bolsters represented by them will be rejected."

Still another specification states that, "Bolsters will be selected at intervals, but not more than one in one hundred and one, for physical test to insure that the requirements are being fulfilled. The supports shall be 4 in. wide and the load shall be applied on the center plate in the vertical tests and in the transverse tests the bearing shall be 12 in. wide and in length equal to the depth of the bolster.

"Any bolster, or any lot of bolsters, may be rejected, which does not, or which do not, meet all the requirements of these specifications."

From the above, it is apparent that in the case of vertical tests it is customary to require the specified load to be applied at the center plate and the bolster supported at the center of the spring seats. Thus, while there is a tendency to call for a bolster having a greater relative strength near the ends, under a central load, or, in other words, to distribute the loading in such a manner as to increase the bending moment over what it would be in a case such as that covered by diagram 1, Fig. 1, the central method of loading is still generally adhered to. That method of loading, wherein one half of the load is assumed to act at the center bearings and one half at a side bearing is illustrated in Fig. 11, the left side bearing being considered in this

instance as has been the practice throughout this discussion. This method has been employed to some extent in strain gage testing, i. e., tests in which the actual elongation or contraction of the metal over a predetermined length of the member was measured by means of an instrument known as a strain gage in order to obtain the actual working fibre stress. If the bolster is loaded at the center plate and a series of strain gage readings taken and the load then applied as shown in Fig. 11, i. e., half the load concentrated at the center of the center plate and the other half at the side bearing, the stress corresponding to a system of loading represented by diagrams 5, 6 and 7 of Figs. 1 and 2, may be arrived at and compared with the calculated stress. This, however, is a laborious process and, moreover, furnishes no means of checking by actual tests, the strength (deflection and set) of a bolster designed in accordance with the systems of loading covered by Figs. 5, 7 and 8.

To bring out this point, the bending moment diagram shown at 9 in Fig. 5, has been selected and completed, the entire diagram being shown in Fig. 12. Now, if it be assumed that a bolster has been designed from this diagram, it would require a concentrated load of approximately 91,800 lb. at the center to create a fibre stress of 16,000 lb. per sq. in. at the upper and lower edges of a section at the center of the bolster. The resulting bending moment under this 91,800 lb. central load at each side bearing would be 619,918 inch pounds instead of 1,090,910 inch pounds, as was assumed in the design, some 43 per cent less.

The calculated section modulus would be equal to 1,090,910 divided by 16,000 or 68.2 which if it is assumed that the calculated and actual stresses check, would result in an actual stress of 9,090 lb. per sq. in. for this 91,800 lb. central load, i. e., the actual stress at the side bearing would be a little over half the calculated value and it would seem to indicate that the testing of bolsters by means of a system of central loading causes bolsters to take set principally at and near the center, whereas, the greater part of the failures in service, which many designers are now trying to overcome by increasing the strength of the bolsters near the ends, is not checked in testing and that testing by this method does not guarantee that the method of designing or that the bolster itself is all that it should be.

A proposed method of testing is suggested in Fig. 13 which we believe would be somewhat of an improvement over the method in which the load is applied at the center. While there may be one advantage of testing with a central vertical load, in that the deflection of the bolster under a static load or a load equal to the static load plus the amount due to oscillation is obtained, this is relatively a small amount, usually not over 0.04 in., or 0.05 in. and it would practically be a fixed amount for all normal bolsters of the same general design. In testing bolsters, it is certainly much more important to duplicate service conditions.

By the system of test loading shown in Fig. 13, a bolster designed from the moment diagram of Fig. 5 and the moduli diagram of Fig. 10, can be loaded in such a manner as to give a certain uniformly distributed fibre stress.

The curves for the calculated stress values of a bolster so designed are shown in Fig. 14, the values for the upper edge being plotted with broken lines and those for the bottom or lower edge with full lines. Two values for each edge are given at the center section as two methods are employed in determining the section moduli, i. e., the bolster center in the other. The bolster center plate ring was not considered in either case. The drop in the value of the fibre stress near the support is necessarily true of all well designed cast steel bolsters. Since depth at the columns is necessary to provide wearing surface, in addition to other considerations, such as thickness of metal, foundry requirements, and the influence on the design at other sections, most bolsters will exhibit a corresponding decrease in fibre stress near the

supports and thus slight differences in the bending moment curves for a distance of, say, 10 in. from the center of the support, are not of great importance, provided the bolster has good end depth.

Strain gage readings taken under this method of loading, should check the calculated stresses. Any appreciable difference could be attributed to the effect of any irregular or abrupt sections. This furnishes one of the principal reasons why design testing is necessary.

Since the method of loading suggested is at variance with the present practice, and is a radical change, it is the intention merely to suggest the method rather than any definite test loads. In case both the calculated and actual test requirements are specified, care should be exercised to see that the two are in harmony, otherwise the more rigid will determine the final design of the bolster and the less rigid might as well be omitted from the specifications. For illustration, let it be assumed that a bolster must meet the design specifications of Example 4 and the test requirements quoted above in which the deflection under a load of 200,000 pounds, must not exceed 0.20 in. and the permanent set not exceed 0.625 in. Now, three conditions must be met: first, the calculated fibre stress must not exceed 9,000 pounds per square inch; second, the deflection under a vertical test load of 200,000 lb. must not exceed 0.20 in.; and third, the permanent set must not exceed 0.625 in.; at this load. In this instance there are three vertical requirements which the bolster must meet in order to be accepted, but in case any one of the three becomes the limiting condition, then the other two requirements become valueless for that design. This may appear to be a rare occurrence, but unless great care is exercised, there is anything but harmony in the various requirements, as is evidenced by the increasing tendency to use one system of loading in design and another method in testing.

The preliminary vertical test load of 80,000 lb. with a deflection of not over 0.0625 in. would make a total of four vertical requirements, but as a deflection of 0.0625 in. for an 80,000 lb. load on a 50-ton design rarely occurs, we have not included the same in the above paragraph. The same is true of the preliminary vertical test loads for the 30 and 40-ton capacities, but not for the 70-ton. The allowable deflection for the preliminary vertical tests is the same for all capacities, i. e., 0.0625 in. The load for the 70-ton is usually taken as 130,000 lb. The axle for a 50-ton car is designed to carry a load of 38,000 lb., whereas the axle for the 70-ton car is designed for a 50,000 lb. load. The 80,000 lb. preliminary vertical test load for the 50-ton bolster is 2.1 times the load for which the axle is designed, while the 130,000-lb. test load for the 70-ton bolster is 2.6 times the axle load. Based on the axle load, it is evident that the test loads are more severe for the 70-ton than for the 50-ton bolsters. The loads for the 70-ton bolster should be 105,000 lb. and 263,000 lb., respectively, to be in proportion to the axle loads instead of 130,000 lb. and 300,000 lb. as seems to be the tendency in most specifications. In addition to specifying loads that are some 23.5 per cent and 14.0 per cent more than they would be if based on the corresponding axle loads, the depth of the bolsters for 70-ton cars is not, as a rule proportionately increased.

The required section moduli as determined by the two methods, i. e., by the formula of Fig. 3 and by the bending moment diagram of Fig. 12, assuming a fibre stress of 16,000 lb. per sq. in., are set forth in Table IV. At the side bearings which are located 13½ in. from the points of supports, the section moduli, according to the formula of Fig. 3, will be found to be 65.0 as against 68.2 by the proposed method. From a point 16¾ in. from the points of supports to the center line, a larger section modulus is required by the formula, being 112.4 at the center of the bolster as against 110.5, or a difference of 1.9. The values obtained

by the two methods are in close agreement at the side bearings and at the center. The proposed method of loading and designing are suggested since this would give a means whereby the design could be checked by testing.

The following method may be used to determine the distance *b* of Fig. 13, which is the loading diagram suggested in connection with a moment diagram similar to the one shown in Fig. 12. By dividing the moment at either side bearing, by the distance from the side bearing to the point of support, shown as *c*, we obtain an amount, which, for convenience, will be termed the "new reaction." The quo-

TABLE IV—SECTION MODULI DETERMINED BY TWO METHODS

Distance from support	Calculated by formula of Fig. 3	Proposed method 16,000 lb. per sq. inch fiber stress
3 ¼ in.	18.2	16.4
6 in.	32.3	30.3
10 ½ in.	53.0	53.0
13 ½ in.	65.0	68.2
15 in.	70.5	70.7
16 ¾ in.	75.3	73.0
20 in.	86.5	79.2
23 ½ in.	95.4	85.1
27 in.	102.4	91.0
28 ½ in.	104.8	93.6
31 ½ in.	108.7	98.6
38 ½ in.	112.4	110.5

tient obtained by dividing the bending moment at the center of the bolster by this new reaction, when subtracted from one-half of the length of the bolster, is equal to the distance *b* which locates the point of application of a load equal to one reaction. By way of illustration, an example may be worked out from the values given in Fig. 12, which are for the 50-in. side bearing spacing. In this instance the bending moment at either side bearing is equal to 1,090,910 in. lb. and by dividing this amount by the distance *c*, which is 13.5 in. for the case in question, the value of each reaction is found to be 80,808 lb. The quotient obtained by dividing 1,767,914 in. lb., the moment at the center of the bolster, by 80,808 lb., the value of the reaction just determined, is equal to 21.88 in. and represents the distance from the points of support to the points of application of the two equal loads, transmitted by the single beam immediately below the testing machine head.

The difference between 38.5 in. which is equal to one half the distance between the bolster supports, and 21.88, which is the distance *b*, is equal to 16.62 in. or approximately 16 ⅝ in. The difference between 21.88 in. and 13.5 in., which is the distance *c*, is equal to 8.38 in. or approximately 8 ¾ in. This latter figure represents the distance *a* minus *b* shown in Fig. 13 and whichever one of the two values proved to be the most convenient to measure in loading the bolster, could be used.

The distance *b* for the 60-in. side bearing spacing would be 17.59 in. and 17.92 in. for the 64-in. spacing. The total load on the former would be 152,660 lb. and 149,804 lb. for the latter, as compared to 161,616 lb. for the 50-in. spacing illustrated in Fig. 12.

The reaction at the end of the bolster support has purposely been termed the "new reaction" in order to distinguish it from the reaction used to form the diagram. Reference to the upper side bearing spacing of Fig. 4 will indicate that this new reaction is equal to the maximum reaction shown at the left of the diagram. Thus, the bolster under a test load of 161,616 pounds will be subjected to a stress at both ends corresponding to that which would have come upon the left end under the conditions shown in Figs. 4 or 5.

It has been the aim in the present article to outline the general principles involved in the design and testing of a truck bolster of a specific capacity, especially as to the method of loading, and as the suggested method of loading for design testing is entirely new, we have purposely avoided giving limiting deflection and set requirements.



SHOP PRACTICE



TERMINAL HANDLING OF LOCOMOTIVES*

BY FRANK C. PICKARD

Master Mechanic, Delaware, Lackawanna & Western, Buffalo, N. Y.

Efficiency and conservation are especially necessary at this time in solving the transportation problem. We are engaged in the business of transporting necessities from where they are produced to where they are needed and the connection between these two places is a railroad, its motive power, vehicles for conveyance, tracks, etc. All must be kept in good condition. The locomotive must be kept as nearly one hundred

per cent efficient as possible and be detained at the terminal as little as possible, and to this end a few suggestions are offered.

When the locomotive arrives at the terminal, the first operation is the cleaning of the fire, or removing it entirely from the locomotive. For this purpose a suitable ash pit is necessary, and one of the best is the water type of pit, open on one side and containing sufficient water space to extinguish the hot cinders. This pit should be provided with a gantry crane and then one man can readily serve 125 locomotives every twenty-four hours, that is in handling the cinders. The labor for cleaning the fires can be handled to the best advantage on a piecework basis.

After the fire has been cleaned, the next operation is to thoroughly clean the machinery and running gear of the locomotive and tender, so that it can be properly inspected. By improved devices which are now on the market, the largest types of locomotives can be thoroughly cleaned in from seven to ten minutes by washing with a combination of fuel oil and water at about 90 degrees, aided by air pressure, which should be at 100 pounds to drive the best results.

An inspection pit, located next to the washing pit, should be long enough to take in the entire locomotive and tender and be equipped with sufficient lighting facilities to enable the inspector to do his work thoroughly. For greater convenience it is desirable that entrance to this pit should be from the outside through a suitable subway.

From the inspection pit the locomotive goes to the engine house, and here the most important factor is the organization. For a terminal caring for approximately 100 locomotives per 24 hours, Fig. 1 shows an organization which is recommended. The organization represented in Fig. 2 may be used when it is desired to specialize between the different classes of power.

In regard to the engine house equipment, about the most important single item is a first class turntable of ample length and sufficiently strong in design, so that it will not spring under the heaviest load. The alignment of tracks across the table is important. Every mechanical man appreciates the layout of tracks, so that in handling locomotives in and out of the house or moving them back and forth for valve setting no time is lost in shifting the table. In climates where considerable snow falls a double drive is desirable, that is, a motor on each end of the table coupled in multiple.

An engine house is not complete unless equipped with sufficient tools to handle properly and promptly any work likely to come in, and the larger terminals should be supplied with

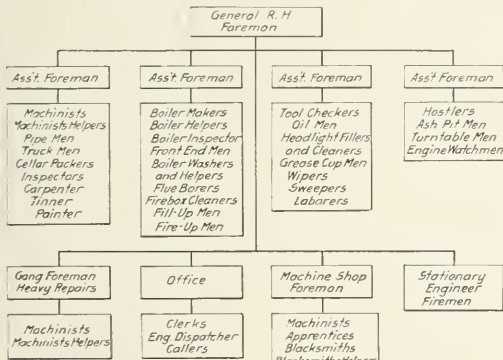

Fig. 1.

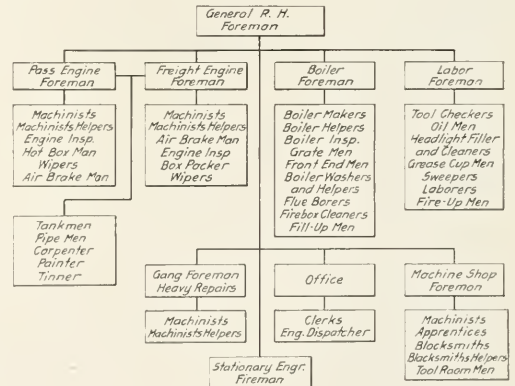

Fig. 2.

cylinder and valve chamber boring bars, a valve facing machine, a crank pin truing machine and portable tool boxes and benches.

A well defined plan of handling the work is needed and no time should be lost from the moment the engineman's report comes in until it is sub-divided among the different foremen and finally done and checked off on the work slips. It is desirable on a division with a large number of locomotives to have a special man assigned as general inspector to cover the entire locomotive and to see that all requirements of the

*Abstract of a paper presented before the Central Railway Club.

federal and government laws are complied with. No roundhouse is complete unless it is equipped with a hot water washout plant of sufficient capacity to take care of all the washouts. This does away with the breakages that are due to expansion and contraction caused by the quick change of the temperature of a locomotive boiler when it is undergoing the washing process. It also tends to save fuel and time in getting an engine up to the required steam pressure.

Suitable drop pits with jacks large enough to readily handle the heaviest wheels are needed and these pits should have adequate drainage and lighting facilities.

No other appliances are of more assistance to the prompt despatching of power than electric and acetylene welding outfits. They are time savers and labor savers.

For handling the coal there are many varieties of docks of the gravity and mechanical type, the former being recommended. The coal dock should be located so that it will cover the locomotives as they approach the enginehouse, this being desirable on account of delays in coaling when the engines are being despatched. It is also desirable to have suitable water cranes located on tracks leading to and from an enginehouse. With these properly placed, no time is lost in moving engines back and forth to give them water, when required. One is desirable for the switch engine movement and another for the road and passenger engines.

A suitable report should be made of terminal delays to the mechanical officers in charge so that they can tell just what time a locomotive arrives and when it is again made ready to depart. This will enable them to make a study of the delays and eliminate possible bad practices.

Of course, there is no doubt that improvements are needed at almost every terminal, but they are harder to obtain now than at any previous time, so we must take the present facilities and do the best we possibly can. Speed up, eliminate lost motion and attend to the little things that go to bring about prompt despatching and furnish the locomotives that the country needs.

DISCUSSION

As a stimulus to the discussion of the subject, the author added to the paper a list of twelve questions, which worked out very nicely, as it gave the members something definite to talk about. The majority of those who spoke favored cleaning locomotive fires on a piecework basis rather than on a day wage. Some roads pay 35 cents per engine for this work. The washing of engines, as described by the author in his paper, was considered very good practice but it was deemed inadvisable to use this system when the temperature got below 10 above zero, as it was difficult to keep the water from freezing on the locomotive. The majority of the members favored the use of outside inspection pits. Mr. McIlvaine, superintendent motive power of the Northern division of the Pennsylvania, stated that the use of inspection pits was practically universal on the Pennsylvania lines. Most of the members thought that two motors would hardly be necessary on their turntables, but that a motor of sufficient capacity should be provided to operate them under very poor conditions.

The majority of the members found that more supervision was necessary under present labor conditions. None of those who spoke found it necessary to use women in enginehouse work except as clerks. A vote taken on the question as to whether each locomotive engineer should have an individual tool box or whether a set of tools should be assigned and kept on the locomotive, showed that the latter system was much to be preferred. Most of the members stated that the locomotives were coaled on going into the roundhouse. The plan of organization shown in Fig. 1 was preferred. Everyone favored having a tool room in connection with the enginehouse and some of the members advocated passing the tools out on check.

The price for cleaning fires on the Lackawanna is 35 cents per engine for locomotives having 55 sq. ft. of grate surface and less, and 45 cents per engine for locomotives having a grate surface larger than that. Thirty-nine cents is paid for washing engines.

LOCOMOTIVE FIRE KINDLER

BY E. A. M.

The locomotive fire kindler illustrated is a valuable device to have in a roundhouse and it aids materially in reducing locomotive time at terminals. Boilers are washed and blown out periodically at about 28 day intervals and for this purpose it is, of course, necessary that the fire be knocked out of the engines. To calk flues and do several other repair jobs the fire must be taken out and also when engines are tied up for repairs for a day or more, it is obviously poor economy to keep the fires.

In order to reduce the time of locomotives at terminal points, some arrangement is necessary to kindle the fires quickly, and the device shown has proved valuable for that purpose.

In operation, all old waste and car shop scrap wood is saved; the coal is placed around the edges of the firebox and the waste and wood in the center. The fire kindler

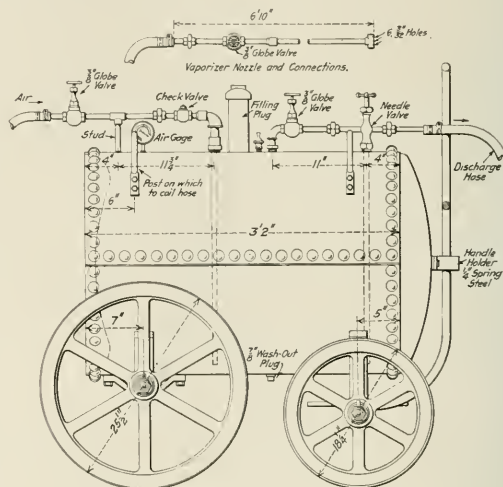

Locomotive Fire Kindler

is then used for spraying the oil around, enabling the fire to get a rapid and complete start. A suitable blower connection applied to the smokestack will then insure the rapid spread of the fire and a very quick attainment of full boiler steam pressure.

The fire kindler consists of a 27-in. by 38-in. reservoir, supported and bolted by means of braces to 2-in. square axles, the ends of which are turned down to 1 1/2 in. for wheels and the extreme ends being threaded and drilled for a 1-in. nuts and taper pins. The front brace has a disk at the bottom, resting on the axle and this provides for greater ease in turning. The device is easily moved from place to place as it is needed. The air hose is connected to the shop air line, the supply of air being controlled by the 3/4-in. globe valve shown. A glance at the piping arrangement on top of the fire kindler will show that the air passes through this globe valve, then through a check valve and down to the tank. On the other side there is an air and

oil outlet, the oil pipe extending nearly to the bottom of the tank. There is a filling plug where the fuel oil is poured in and the bottom of the tank is tapped for a $\frac{7}{8}$ -in. plug for use in washing out. Four posts are provided, two on each side, for coiling the air hose on one side and the discharge hose on the other. There is also an air gage for registering the tank pressure, and a spring clip to keep the handle up out of the way such as would be the case if it were allowed to rest on the floor.

The discharge hose is connected on the outer end to a

A DIFFICULT CYLINDER WELD

BY D. A. DONALDSON
Apprentice Instructor, Baltimore & Ohio

The importance and value of an oxy-acetylene welding equipment to a railroad shop or roundhouse terminal is well known and is still further demonstrated by the successful repair of the serious cylinder break shown in the accompanying illustration.

During the cold spell of last winter one of the B. & O.



B. & O. Engine Cylinder Successfully Welded by Acetylene Process

vaporizer nozzle which is shown in the upper part of the illustration.

By adjusting the various valves it is possible to obtain just the right proportion of air and fuel oil through the nozzle, which is placed in the firebox door. The device is inexpensive to make and has given good results in actual service at enginehouse terminals.

locomotive cylinders froze while waiting at the cinder pit. The piece shown in Fig. 1 was broken off from the left cylinder and valve chamber as a result of water being confined in the valve chamber and freezing. The peculiar position of the break made a weld seem impossible, but nevertheless it was attempted. The results exceeded the highest expectations and a total saving of more than two-

thirds the cost of a new cylinder was effected. It is almost impossible to figure the saving due to putting this locomotive back into service in less than a week, as was done. Had a new cylinder been applied at this terminal, the engine would have been in the shop at least a month.

The broken surfaces of the cylinder and the piece which was broken off were chipped in the usual way, as shown in Figs. 1 and 2. Owing to the location of the break, a piece had to be cut out in order to allow welding the inner wall. This is shown in Fig. 1 by the series of holes in the right side. After this picture was taken another break was found and welded.

An iron ring was turned and drilled to fit over the studs and served as a clamp to hold the piece in place on the cylinder. After it was bolted up, a furnace of firebrick was built entirely around the cylinder, as shown in Fig. 3. Openings about 12 in. square were left in the brick wall for firing. Sheet-iron lids were provided to fit the openings as shown. The fuel used was coke and charcoal. In this manner the cylinder was kept at nearly a red heat during the entire welding operation, which eliminated the possibility of expansion cracks, such as are usual in welding large castings. The cylinder was heated and then such bricks as covered the break were removed and welding started. Three men worked one day on the job, two alternately handling the torch, while the third kept the cylinder at a uniform temperature. The usual flux was used with the filling metal. After the weld was completed, the furnace and clamp were removed and the part covered by the clamp on the joint, was built up.

A light cut with the facing machine finished the job. The cylinder is now as good as a new one and the engine is still out making mileage. Very little stripping was necessary, the cylinder and valve chamber heads and lagging only being removed. The piston was left in the cylinder and was not injured.

As stated before, the successful weld of this cylinder break only goes to show the necessity and value of a welding equipment at locomotive repair shops and round houses. There is almost no limit to the amount and variety of work that can be done by an experienced welder.

HANDLE CHISEL GUARD

BY HENRY SPERL

Tool Foreman, Erie Railroad, Susquehanna, Pa.

The chisel guard shown in the illustration is in use at the Susquehanna shops of the Erie, and has been found effective in preventing rivets and bolt heads from flying about when they are being cut. It is made of wire netting,

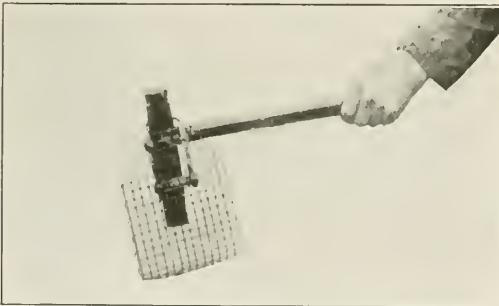

Handle Chisel Guard

cut to the shape shown and riveted to a piece of $\frac{1}{4}$ -in. wire bent in the form of a loop. This loop fits over the head of the chisel and is reversible, so that the chisel may be used either right or left.

While the use of such a safety device will result in some little inconvenience to the workman, any care taken to avoid accidents is well worth while. There is no comparison between the inconvenience resulting from the use of a safety device and the inconvenience to a man who has received injury.

LOCOMOTIVE SIDE PLAY

The maintaining of side play or lateral motion on driving wheels is recognized by railroad officers as one of the important items of locomotive maintenance. Broken driving boxes, broken rods, and other costly engine failures are often directly traceable to excessive lateral motion and many locomotives are held at roundhouses waiting for one or more pairs of wheels to be dropped to take up side play.

Many different methods of applying hub liners to wheel centers and repairing the hub faces of driving boxes are in use, each method as a rule, having some good points in its favor. Such items as material costs, length of time to apply and facilities for applying should not be used altogether as a basis on which a selection is finally made; rather the length of service ought to be the deciding feature. The original cost or the convenience of initial application is insignificant when compared with the damage that may be brought about by poorly designed or poorly applied hub liners. When power is scarce, the loss of a locomotive held out of service for one or two days to have side play taken up is a serious matter and costs the company much more than it would to apply the hub liners properly in the first place.

As a comparison to bring out and develop the best method of maintaining lateral motion, the four methods most commonly used will be described. Owing to such a wide range of labor conditions it is impossible to furnish accurate comparative costs, but each method as described will be explained in detail so that the reader can easily form an opinion as to which is the best from an economical and a service standpoint.

Boiler Plate Hub Liner; Babbitt on the Box.—This method consists of applying a boiler plate hub liner to the wheel center by spot welding, after which the wheel is put in a lathe and the hub faced smooth. The hub face of the driving box is built up with babbitt.

Applying the boiler plate liner to the wheel center gives a very hard surface bearing and by spot welding and also welding at the edges there is small liability of the liner coming off. No machining of the liner is required, as it is simply punched out as near to shape as possible and laid in the recess cut in the wheel center. As it is welded around the edges it is immaterial how rough the edges are prior to welding. This method of preparing the wheel is excellent as it gives a lasting job at small cost, and the distance between wheel hubs is maintained constant.

The driving box hub face is prepared by pouring babbitt in a dove-tailed groove and facing it off to the required thickness on a boring mill. The only objection to the use of babbitt on the driving box is that a locomotive with a long rigid wheel base exerts a heavy pressure on the hub faces in rounding curves. The metal is far too soft to withstand this pressure and soon wears out if it is not melted out by the high temperature due to the friction. Brass on the hub face of the box would give much longer service.

Brass Hub Liner; Boiler Plate on the Box.—In this case the wheel hub is prepared by applying a brass liner in two halves, using countersunk head bolts through the wheel center with the nuts outside. The wheel hubs are drilled from a standard template and the brass liners are machined and drilled to this same template so that in taking up the side play it is only necessary to remove the old liners and apply new ones of the required thickness.

The time saving feature of this practice is that the hub-

liner can be changed without unwheeling the engine. The process consists of dropping the pedestal binders and driving box cellars and backing out the liner bolts as the heads are brought successively under the journals. Two bolts can be removed in one position and then it will be necessary to move the engine to get the other two. With this kind of hub liner there is a considerable saving over the time and effort required in unwheeling an engine, as is necessary with most of the other kinds.

In actual practice this arrangement of hub liners is giving good service on one of the smaller eastern roads whose standard practice is to apply a boiler plate side bearing to the driving box by spot welding. The advantages of welding a boiler plate liner on the driving box are the greater strength of the box, increased bearing surface, longer life, lower cost and less material planed off from shoe and wedge faces because these faces are not warped out of parallel as would be the case where a box is heated by pouring on babbit or brass liners.

As the brass hub liner is softer than the boiler plate on the box it takes practically all the wear, and thus whenever the lateral play becomes excessive it can be taken up in less than a day's time at any roundhouse. It is usually good practice to head over the bolts on the outside of the nuts and thus insure the hub liners against working loose.

Cast Iron Hub Liner; Brass on the Box.—Some roads still adhere to the practice of using cast iron hub liners in spite of the many objections to it. The use of cast iron on the wheel hub is not recommended because it breaks or crumbles so easily, even when new, and when half worn out has practically no strength to resist the constant pounding to which it is subjected. The cast iron liners are applied by countersunk head set screws or by simply drilling straight holes and driving in a neat fitting cast iron plug. This latter method has a tendency to break or crack the hub liner and does not give good service. This method is economical for initial application, but, based on the length of service, it is one of the most costly.

The same criticism of the use of brass or babbit in the driving box hub faces applies to this method as to those previously described. Brass driving box side bearings give more or less unreliable service because many shops using scrap brass do not get a uniform mixture and often burn it. When this happens the liners are liable to break and fall off, or crumble under the heavy pressure. Furthermore, too great dependence is placed on the contraction to hold the liner on the box face, and in case of a hot box it is liable to come loose and either fall off or be pounded off.

Cast Brass Hub Liner; Babbit on the Box.—In using cast brass hub liners the wheel center recess is prepared for the liner by screwing in several countersunk head set screws and then pouring on the brass. As the metal cools and contracts, it cracks in one or more places, but due to the countersunk head set screws it will not come off. After both wheels have been poured it is necessary to put the wheels in a lathe and face the hubs to the required thickness. This is an expensive practice and the preparations also take longer than those previously described. Handling the wheels to pour the brass on the hubs is expensive and many shops are not equipped for this work. The driving box hub faces are prepared by building up with babbit. It is very doubtful if the length of service obtained from hub liners of this type warrants the cost of application.

While it has been suggested in all cases to use a boiler plate liner, it is not necessary, however, to limit the material particularly to boiler plate, for a liner forged in the blacksmith shop out of a scrap car axle will give equally as good service.

It is possible to use a steel liner on both the box and the wheel hub. The idea that two medium hard steel surfaces will not run face to face and give good service is not borne

out in practice, for it is a fact that several roads are now using this method for maintaining the side play on their locomotives. In this case the only question is that of lubrication and with so many hard grease cellars in use it is possible to drill an oil hole from the recess in the top of the driving box diagonally to the side bearing, thus securing proper lubrication without the need of providing detachable oil cups.

In conclusion it may be stated that the second method gives the best results of the four methods described, but a bearing of steel against steel offers attractive possibilities if proper attention is given to lubrication.

PNEUMATIC BENCH CLAMP

BY G. C. CHRISTY

Master Mechanic, Yazoo & Mississippi Valley, Vicksburg, Miss.

The time and effort required to lift one main rod brass from the bench and clamp it in a vise may be comparatively small, but if enough brasses have to be handled and it is possible to save a little time on each one, the total resultant saving will probably be surprising. Such at least, has been the experience of the Yazoo & Mississippi Valley at Vicks-



A Convenient Bench Clamp.

burg, Miss., in the use of the pneumatic bench clamp illustrated.

The machine consists of a brake cylinder bolted to the under side of the bench with its push rod pointed down and direct connected to the lower end of a 3/4-in. by 3-in. vertical iron bar which moves up and down through a guide in the bench. The sheet iron casing below the brake cylinder is a

guard to prevent workmen from getting their feet caught between the push rod and the floor. The upper end of the bar is notched and provided with a movable jaw which may be adjusted to any height suited to the work in hand. The supply of air to the brake cylinder is controlled by a 1/2-in. cut-out cock which has been drilled through the side so that with the handle in the closed position there is a direct opening from the cylinder to the atmosphere. This releases the clamp and allows the work to be quickly removed or changed to a more convenient position.

The particular clamp described was applied to a bench on the rod job and used largely for holding main rod brasses while being chipped or filed. Its application, however, could be successfully extended to holding many other kinds of locomotive parts and thus eliminate handling to and from the bench and hand vise.

FLUE SETTING

BY R. J. H.

As the setting of flues is about the last thing to be done on a boiler before the test is applied, it is desirable that this work be done as quickly as possible. The mandrels shown in the illustration were designed especially to facilitate flue setting and they have aided materially in speeding up the boiler shop work on one of the large roads in the middle west.

The method of using these mandrels in the setting of flues is as follows: The flue is driven to place by the man in the front end with the front end mandrel. The moment the flue has been driven far enough, the flue setter in the firebox

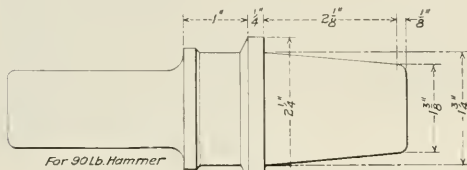

Combination Mandrel and Driver.
For 2" Flues. Front End.

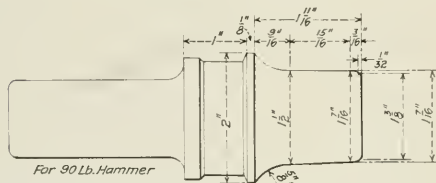

Combination Mandrel and Flaring Tool.
For 2" Flues. Back End.

Mandrels Used in the Setting of Flues

to mandrel and bell it with the back end mandrel. The starting of the air hammer at the back end is the signal for the man in the front to stop his hammer and hold it against the mandrel to keep the flue in place while being mandreled and belled at the back end.

After all the flues have been flared, the man in the firebox proceeds to expand the flues with a sectional expander, so constructed that it completes the turning over of the bead. The flues are then calked and rolled. While this work is being done, the flues are rolled at the front end and one in ten are beaded. For 2-in. flues, the holes in the front flue sheet are drilled 2 1/16 in., in the back sheet 1 15/16 in. No. 40 copper ferrules are used. Both mandrels are made "just large enough" for the work without sticking.

EFFECT OF BUSHING THE HIGH PRESSURE CYLINDER OF AN 8 1/2 INCH CROSS COMPOUND COMPRESSOR

BY R. M. DURNFORD

The Westinghouse 8 1/2 in. cross compound air compressor may be adapted to passenger service where the demands for air are exceptionally high by reducing the diameter of the high pressure air cylinder to 8 1/4 in. and leaving the remaining cylinders unaltered, the following changes in the action of the pump being brought about.

The intermediate pressure of the standard compressor with a 9-in. high pressure air cylinder figures out to be 41.8 lb. gage. This intermediate pressure is a propelling force acting on one side of the high pressure air piston and acts in conjunction with the intermediate steam pressure to drive the second stage side of the compressor, often referred to as the "floating piston."

The reduction in diameter of the high pressure air cylinder means a greater intermediate air pressure figuring out to 57.4 lb. gage. Multiplying the pressure by the area of the 8 1/4 in. piston gives a greater effort in pounds than is the case in the standard compressor with an intermediate pressure of 41.8 lb. acting on a 9 in. air piston. The increase of driving effort is $3068 - 2662 = 406$ lb.

When the standard 9 in. air piston completes its stroke against a main reservoir pressure of 140 lb., it is subject to a resistance of 8,906 lb. The altered compressor with the 8 1/4 in. piston acting under the same circumstances is subject to a resistance of 7,484 lb., only 1,422 lb. less than the standard compressor.

Since the decrease in resistance and the increase in intermediate pressure propulsion are both helping to drive the "floating piston" more rapidly, therefore, by adding them together we get 1,828 lb., or nearly a ton added to the balance of power on the second stage side of the compressor. This will certainly act to speed up the "floating piston" which will promptly complete its stroke; the completion being well in advance of the other side of the compressor.

Now considering the first stage side of the compressor, the live steam at, say, 180 lb., drives the high pressure steam piston, but opposing it on the other side is a back pressure of 52 lb. (intermediate steam pressure), subtracting this back pressure from the live steam pressure on the other side of the piston gives an effective steam pressure of 128 lb. per sq. in. This pressure acting on an 8 1/2 in. steam piston gives a thrust of 7,264 lb.

In the low pressure air cylinder (14 1/2 in. dia.) of the standard pump with an intermediate air pressure of 41.8 lb., the greatest resistance that will occur will be 6,910 lb. The steam thrust can easily overcome this, but to avoid slowing down at the end of the stroke, by-pass grooves are placed in the walls of the low pressure steam cylinder so that when the "floating piston" is at the extremities of its stroke the intermediate steam pressure is by-passed to the exhaust. This removes the back pressure from the high pressure steam piston and the steam thrust is then much greater so that the first stage side completes its stroke in a manner which insures a prompt and complete action of the reversing mechanism.

Now considering the altered compressor with its high intermediate air pressure we find the resistance is greater, being in fact 9,478 lb. This would appear to be more than the effective steam thrust of 7,264 lb. could overcome, but the resistance only occurs to this extent at the end of the stroke. Before the resistance has increased to such an extent as to stall this side of the compressor the other side, which was considerably advanced, will have completed its stroke and the back pressure on the high pressure steam piston will be relieved through the by-pass grooves. This leaves the boiler

pressure acting with a thrust of 10,214 lb. to overcome the peak resistance of 9,478 lb. in the low pressure air cylinder, so that the stroke is readily completed and the reversal takes place.

In the case of the standard compressor, the "floating piston" is so little advanced at the end of the stroke that the full thrust of 10,214 lb. only occurs at the very end of the stroke and has no opportunity to speed up the stroke of the first stage side.

In the altered compressor with the "floating piston" distinctly advanced at the end of the stroke over the first stage side, the relief of the back steam pressure takes place much sooner, and the large steam thrust of 10,214 lb. acts through all the latter part of the stroke; this speeds up the first stage side of the compressor, which results in a greater number of strokes per minute, therefore giving the compressor more capacity.

In operation this compressor will develop a higher temperature in the air cylinders on account of its increased speed. The higher intermediate air pressure will tend to heat up the low pressure air cylinder more than in the case of the standard pump. Nevertheless the high pressure air cylinder will be subject to the higher temperature and this with less cylinder wall to radiate the heat will require that special attention be paid to the lubrication of the cylinder.

The figures presented in this article are based on 180 lb. steam pressure and a main reservoir pressure of 140 lb. This shows that the altered compressor is well suited for passenger service where these pressures prevail. The standard compressor working under these conditions would work far too slowly to handle the required amount of air promptly, at times when the demands for air were high. The arrangement of air compressor described above has been tried out on the Grand Trunk and given satisfaction; its use is being extended.

FRONT DECK BRACE

BY JOSEPH SMITH
Baltimore & Ohio, Lorain, Ohio

To overcome the frequent delays due to the breaking of front deck braces on switch engines the brace marked *A* and shown in the illustration was devised by J. Wilson, blacksmith foreman, Lorain shops.

A front deck brace *D* had been in common use and on one engine in particular a good deal of trouble was

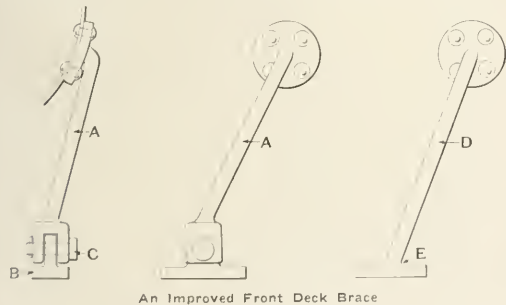

experienced and it was necessary to shop the engine frequently on account of the foot of the brace breaking off at point *E*.

To overcome the difficulty a brace similar to *A* was applied to this locomotive two years ago and has given no trouble since. The jaw of the brace is of the general dimensions shown and is connected to the bracket *B* by a 1 3/8-in. steel pin *C*.

It is hoped that the accompanying illustration may offer a helpful suggestion to others who are having difficulty with broken front deck braces.

BALL BEARING CRANK PIN

BY B. P. FLORY
Superintendent Motive Power, New York, Ontario & Western, Middletown, N. Y.

The accompanying illustrations show the application of a steel ball bearing to the front crank pin of the 2-10-2 locomotives used on the New York, Ontario & Western. When these engines were first received they had a brass ball bearing



Fig. 1—Ball Bearing Front Crank Pin, 2-10-2 Class

which would crush out on the side and break off the collar on the crank pin, allowing the rod to come off.

To obviate this difficulty, the arrangement shown in Fig. 1 was devised by William Pohlman, general foreman at the

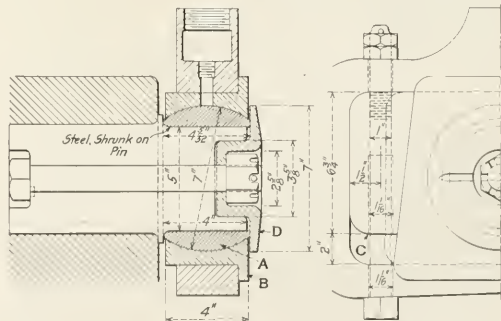

Fig. 2—Detail of Ball Bearing Crank Pin and Rod Brass

N. Y. O. & W. shops, Middletown, N. Y., and it is giving very satisfactory service.

Referring to Fig. 2, a steel ball bearing *A* is shrunk on the original crank pin. The brass bushing *B* is made in two sections, being held together by the wedge *C* and making a running fit on the ball bearing crank pin. In case of ex-

cess-ive wear, the rod would be held on the crank pin by the collar *D* as is customary.

The advantage of this form of front side rod connection is in the reduction of strain on the rod when the locomotive is rounding a curve. It is especially valuable and, in fact, necessary, on a locomotive with a long rigid wheel base.

PROLONGING THE LIFE OF CUTTERS IN DAVIS BORING BARS

BY CHARLES TRIMBY

At the Kansas City shops of the Missouri Pacific a method has been devised for increasing the life of cutters used in the Davis boring bars for boring out car wheels. The way in which this is done is clearly shown in the sketch.

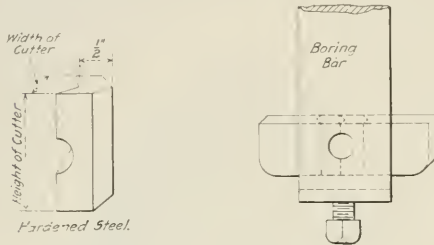

Inserts Double the Life of Boring Bar Cutters

Two pieces of steel are shaped to fit between the cutter, increasing the space between them one inch. This doubles the life of the cutters and effects a considerable saving, especially with the present price of high speed steel.

CUTTING TOOL LUBRICATION

BY R. B. HUYETT, M. E.

Progress in the cutting of metals and in the lubrication of cutting tools, can be divided into three periods of evolution. The first period is often referred to as the good old days of the backyard shop when the boss and his workmen vied with each other in the performance of difficult work requiring great skill, owing to the lack of proper equipment. Each shop was limited in the quality and quantity of its product by the skill of the individual workman. During this period, the time necessary to complete a piece of work was a secondary consideration. The workman was expected to use his skill in performing the work as nearly perfect as possible, regardless of the time consumed in so doing. The machine tools then employed, while they accomplished wonders in comparison with hand work, were not equipped to perform the greatest amount of work in the shortest time. Lubrication of cutting tools was unheard of and unnecessary. The machines were not as yet built to run at high speeds.

The second period of evolution dawned with the introduction of the semi-automatic and automatic machines and quantity production. Up to this time, the capacity of the machine had been limited by its own strength and speed, or rather by the absence of both, and not by the quality of the cutting tools. The introduction of quantity production necessitated the design and construction of machine tools of greater strength and speed. Then it was found that the cutting tools (all low carbon) would not stand up under the speed of which the new machines were capable, as the friction at these speeds generated enough heat to soften the tools and make them lose their cutting edge.

To remedy this, experiments were made along the line of reducing the friction of cutting. Friction was reduced in

bearings by lubrication, why not here? So a squirt of oil now and then was tried on the theory that some might get between the tool and the work and grease the cutting edges. The futility of trying to eliminate or reduce this friction soon became apparent, as nothing could be gotten between the cutting edges of the tool and the work. It was found that a little lubricant at the rake of the tool where the chip slides back over it might do some good, but only a very little. At this time, for some unaccountable reason, it did not occur to the experimenters that, although they could not prevent the great friction at the cutting point and in this way prevent heat, they could arrange to dissipate it as fast as it was generated and, in this way, prevent the tool from becoming the conductor and burning. Instead of developing a means of taking the heat away from the tool they developed a tool steel which, as they thought at the time, could withstand the heat. This was then called high speed steel, and was similar to that in use today.

In the third and present period machine tools are designed with much greater cross-sectional area, larger and longer bearing surfaces, special alloy steel parts and greater driving power. These improvements make them capable of such high speed as to generate sufficient heat to destroy the cutting edge of even the high speed steel tools which had been thought immune from heat.

Up to this time, the manufacturers of high speed steel tools claimed that their tools should not be used in connection with coolant. It was discovered, however, by users of the tools, that when a $\frac{1}{4}$ -in. or $\frac{3}{8}$ -in. stream was circulated over the tool, there was a very marked lengthening of its life. Working, perhaps on the theory that if this small amount of coolant was good, more would be better, many progressive engineers tried the use of more.

Among these experimenters was F. W. Taylor, who arranged to circulate without pressure, a large stream of coolant instead of the small $\frac{1}{4}$ -in. and $\frac{3}{8}$ -in. streams. The results were remarkable. As much as a 40 per cent increase in cutting speed was found possible with less deterioration to the tool and a far smaller number of tool grinds. To quote from Taylor's book on *The Art of Cutting Metal*: "In cutting steel, the better the quality of tool steel the greater the percentage of gain through the use of a heavy stream of water. The gain for the different types of tools in cutting is:

a. Modern high-speed tools.....	40 per cent
b. Old style heavy-hardening tools.....	33 per cent
c. Tempered tools.....	25 per cent

Such a statement as this started investigation in the right direction and the possibilities for increased efficiency by scientific cooling of the cutting tool are gradually being more and more recognized. However, there still exists a deplorable amount of indifference to these possibilities even in many otherwise progressive shops, as is evidenced by the smoking tools and hot chips. It will pay any executive interested in increased profits to investigate these conditions. The absence of smoking tools or hot chips is not always conclusive evidence that enough coolant is being used because the machines may be slowed down.

What is the difference between a lubricant and a coolant? A careful analysis of the subject, based on actual tests, has shown that the principal function of a stream of liquid over the cutting tool is to carry away the heat generated by the friction of cutting metal with metal. While there is a slight lubrication at the rake of the tool where the chips slide off, the real function of the liquid is to carry away the heat from the tool and prevent its temper from being destroyed. Lubrication therefore is a misnomer and the word "coolant" is a much more appropriate term. To quote from Becker's work on high speed steel: "While the word lubrication is in common use in this connection, it really is a misnomer to speak of lubrication in connection with metal cutting. It is quite impossible to force oil or other substances between

the tool and the chip. The purpose of the so-called lubricants in the main is merely to assist in carrying away heat from the place where the work is being done, thus keeping down the temperature of the cutting edge and lip of the tool below the point where softening will begin."

VOLUME OF COOLANT NECESSARY

The size of the stream of coolant to be used depends on the speed of the machine, the depth of the cut, and the kind of material. The easiest and only sure way of knowing when enough coolant is being used is to run the machine at its maximum speed from the standpoint of the strength of machine, material and tool. If the tool smokes or the chips come off hot at this speed, an insufficient amount of coolant is being used and the flow should be increased. It is far better to use too much than too little coolant and Becker puts it this way:

"The small streams customarily used are quite ineffective. It is necessary to deliver gallons of coolant where it has been customary to deliver pints. The heavy streams serve another useful purpose in cases where the chips come off small or well broken up in that they carry or float them out of the way."

Since to cool is the prime function of the liquid, it naturally follows that the best liquid to use is that which possesses the greatest cooling qualities. The lighter and therefore more easily evaporated the liquid, the greater its cooling qualities. Consequently, water fills the necessary requirements when properly mixed with a sufficient quantity of some good cutting compound to eliminate the corrosive effects of water alone. Such water solutions are not only much better coolants than pure oils, but are far cheaper. Oils pick up heat slowly and release it more slowly while water picks up heat quickly and releases it more quickly.

It is not sufficient that a copious flow of coolant be used for a great deal depends on the manner of application. It must be directed at the right point and delivered at a slow velocity.

According to Taylor, "a series of experiments has demonstrated that water thrown directly upon the chip at the point where it is being removed from the forging by the tool will give higher allowable cutting speeds than if used in any other way." Further along he says: "After deciding to try experiments upon the cooling effect of water when used upon a tool, it was our judgment that if a stream of water were thrown upward between the clearance flank of the tool and the forging itself, in this way the water would reach almost to the cutting edge of the tool at the part where it most requires cooling, and that, by this means the maximum cooling effect of the water would be realized. We therefore arranged for a strong water jet to be thrown between the clearance flank of the tool and the flank of the forging and made a series of experiments to determine the cooling effect of water with various feeds and depths of cut. So confident were we of the truth of this theory that we did not deem it worth while to experiment with throwing streams of water in any other way until months afterward, when, upon throwing a stream of water upon the chip directly at the point where it is being removed from the forging by the tool, we found a material increase in the cutting speed, and thus our first experiments were rendered valueless.

"Practically great difficulty will be found in getting machinists in the average shop to direct the stream of water on the chip in the proper way as indicated, because when a sufficiently heavy stream of water is thrown upon the work at this point it splashes much more than when thrown upon the forging just above the chip; and a machinist prefers slower cutting speeds and less splash. The most satisfactory results are obtained from a stream of water falling at rather slow velocity, but with large volume."

MEANS OF DELIVERING COOLANT

Machine tool builders have often overlooked the necessity of supplying adequate coolant circulating facilities on their machines and in order to overcome this defect some users have gone to considerable expense and trouble to install a gravity system to provide the proper flow and eliminate the troubles of the gear-type pump, such as loss of prime, clogging, short life, etc. The installation of a gravity system costs several times per machine what it would to provide each machine with an efficient individual pump at the present time. By installing gravity systems, users of machine tools have done nothing more than trade the troubles incident to the use of the old gear-type pump for those of the gravity system. With a gravity system in use, it is necessary that all machines connected with the system use the same grade of coolant. It is unsanitary, requires constant attention and, if the least thing goes wrong, every machine connected with the system is put out of commission until the defect can be repaired.

Many machine tools are still being furnished to the users with small capacity pumps and small sized piping. This necessitates the changing of the circulating system on machines by the users. Although it seems uneconomical it is far better to throw away the small capacity pump and piping than to use it. A few dollars spent to get a pump and piping of the right capacity will be saved many times over by the increase in production and the lowered tool expense.

BENCH DRILL

BY G. C. CHRISTY

Master Mechanic, Yazoo & Mississippi Valley, Vicksburg, Miss

The bench drill illustrated was devised and tried out at the Vicksburg, Miss., shops of the Yazoo & Mississippi Valley and has given good satisfaction in actual practice. It consists of an air motor, socket and twist drill substantially supported on the bench and bolted to a framework which carries an adjustable table. This table has movement in



Air Motor and Bench Drill

three directions, so it is a simple matter to center any work requiring drilling.

The machine is especially adaptable to such work as drilling holes in rod bushings, cotter key holes in wrist and knuckle pins, etc., but its principal advantage lies in the fact that small drilling jobs do not need to be taken to the

drill press, but may be done at the bench as needed. This will save many steps and much time previously spent in waiting for work at drill presses which are usually overcrowded. In large shops there is most always more drilling to do than can be quickly handled and the installation of some such home-made machine as the above bench drill would help relieve the situation.

INDISCRIMINATE USE OF THE INJECTOR CAUSES BOILERS TO LEAK*

BY GEORGE AUSTIN

General Inspector Boilers, Atchison, Topeka & Santa Fe

Working the injector too much while the engine is standing, is the secondary cause of many firebox leaks and failures, on account of causing extreme variations of temperature between the upper and lower parts, due to injecting a large quantity of water at one operation. Heavy clinkered fires, short firing, or other causes which tend to cause poor steaming, operate to produce unequal temperatures. Poor injector work is also a close second in causing corrugating and cracking of firebox plates, and especially so when aided by bad water conditions. The only excuse for reviewing the injector subject, is that personal observation, on our own road shows these matters are not as well understood by some of those in direct charge of the locomotive as they should be, or if understood, their importance is not fully appreciated. Many enginemen are good boiler men. They rarely make a boiler failure, and then only when it is unavoidable. Others are good at everything else, but, if there is a chance to cause a leak in the firebox of their engine, they are pretty certain to make use of it, either through ignorance or indifference or both. Some of our enginemen get from a fourth to one-half greater mileage from a set of flues of the same type of locomotive in the same service than others, the principal reason for which will be found to be better injector work.

John Purcell, assistant to the vice-president of the Santa Fe, has prepared a book on the care of locomotive boilers and their appurtenances, one of the rules in which reads as follows:

"Engine crews and hostlers should be instructed to use the injector as little as possible when the engine is standing. Boilers should have at least two-thirds of a glass of water when set out for service. Incoming engines should have nearly a full glass of water before the crew leaves them, and the water should be put in while the engine is moving from the train to the ash pit. Use of the injector, while the engine is standing, should be avoided whenever possible to do so. It must be understood, however, that safety of the boiler is the first consideration, but that can be had by using the injector frequently for short periods. Instead of injecting large quantities of water into the boiler at one operation, a good safe rule to follow is not to put in more than one-half an inch of water at any one time while the engine is standing."

The above rule is as good a rule as the book contains, and our men who understand and live up to it are good men with the boiler, as well as with the rest of the machine. They know that when they start an injector, there is a stream of water about 200 degrees colder than the boiler, entering it at a rate of from 40 to 100 gallons per minute, and that this colder and heavier water sinks to the lower parts of the boiler shell and firebox water spaces filling up those parts, and if continued, cooling and shortening all parts in proportion to the reduction of temperature. To illustrate how much the cooler portion shortens, a flue 20 feet in length will change its length one-sixty-fourth of an inch for each 14 deg. change in temperature. Therefore, if

only 112 deg. difference in temperature is produced between the upper and lower parts of a boiler, the bottom of the boiler is $\frac{1}{8}$ in. shorter than the top. So are the lower flues, which are in this cooler strata, and it becomes a tug of war with the odds in favor of the hot ones, because there are more of them; therefore, the bottom flues leak most frequently. If a 20-foot flue will change its length one-sixty-fourth of an inch for every change of 14 deg. in temperature, a 10-foot side sheet will change its length one-sixty-fourth of an inch for each change of 28 deg. and you can believe there is much more than 112 deg. difference. A difference of 200 deg. is not uncommon, and we have a record of 244 deg. or more than $\frac{1}{8}$ in. difference in length between the upper and lower parts of a firebox side sheet. The cooler part must contract and the process causes the hotter and longer part to buckle out slightly between the staybolt rows and assume a slightly wavy form, the staybolt being in the trough, or lowest part between the waves. This bulging or wave forming crimps the end of the bolt on the fire side of the plate and opens slightly on the water side and breaks the joint. This starts the staybolt leak, which most frequently shows when engines have stood a few minutes at the ash pit after the engine crew has injected the water which should have been put in before they left the train, or while coming from the train to the ash pit, or it is caused by the hostler using the injector before, or after engines are placed in the roundhouse. In short, the engine crew did not handle the water according to the best practice for the good of the boiler and the conditions prevented the hostler from doing so.

One or two shocks with the injector does not always start flues leaking, but if the flues are near the leaky point, it will usually start them leaking, and any one who will do it once unnecessarily, does it through ignorance or indifference, and will do it any time the injector is started. There are times when it may seem impractical to do the best thing for the boiler, but there are so many times it is just as easy to do it as not, that the engineman who adopts the system becomes a good man with the boiler and when he once acquires the habit he will hold to it.

Flue and staybolt leakage is frequently attributed to cold air entering the firebox, but when one considers the relative density of air and water, there seems slight probability that cold air can have any appreciable effect in causing firebox leaks. Consider for example, that the fire, when the engine is working, reaches a temperature of 2,600 deg., and the water in the boiler at 225 lb. pressure gets to 396 deg. and yet the high temperature of the fire, as shown by tests does not heat the plates above 450 deg. if they are clean. This is because the greater density of the water gives it the power to absorb heat as fast as the flames can give it to the plates. Therefore, cold air will have as little effect to cool plates when backed by hot water as the flame has to heat them when backed by water, but cold air entering the firebox does affect the steaming. We trade water for steam while the engine is working, and trade a tight firebox or flues, or both, for leaky ones, while drifting down hill or standing at stations.

The use of the blower on the modern large boiler has little effect to promote circulation. It is true that it will maintain the steam pressure, but the cold water goes to the bottom just the same, and using the blower maintains the top temperatures while the bottom temperatures continue falling as long as the injector is operated.

A clean fire gives the best circulation, and no particular harm results to firebox sheets, but with a heavily clinkered fire, or an oil burning engine with considerable of the area of the lower parts of the firebox sheets covered with brick, there is a very serious doubt whether the use of the blower while using the injector is not altogether the wrong thing to do, for the reason that there is no circulation below the

*From a paper presented before the Western Railway Club.

fireline. The hotter water circulates on the top of the cold water in the water leg of a locomotive firebox just the same as if the mud ring was raised that much, there is no circulation unless there is heat to produce it. When there are 8 to 12 inches of clinkers in a coal burning engine, there is no circulation, when the engine is standing, below the top of the clinker. In an oil burning firebox there is no circulation back of the brick work, which covers the heating surface of the firebox plates, until the bricks become hot enough to produce it, and it seems very likely that condition is responsible for some of the corrugating and cracking of firebox sheets, and leaking flues and staybolts in oil burning engines.

There are no doubt many who are somewhat skeptical of the importance of operating the injector only when the engine is working, that is, if it can just as well be avoided. There is not a student or investigator of the subject, but will agree to the truth of what has been said here. It is too often the case that flue failures are classed as unavoidable and passed without investigation, or the cause is attributed to poor care in the roundhouse, which is very unfair to the boiler men, unfair to the company and equally so to the man who was responsible, because of permitting him to become careless in his handling of the locomotive and acquiring habits which depreciate his work. By encouraging our engineers and hostlers, not to use the injector when the engine is not working unless it is absolutely necessary to do so, and favor the boiler all possible we will get a better performance of boilers and engines and less frequent and extensive repairs will be required.

In connection with the subject of injector and blow off cock use, it must be apparent that railroad companies should require their firemen to obtain a reasonable knowledge of the effects of producing unequal temperatures before promoting them to take charge of an engine. Hostlers also, should be required to know how to properly care for the locomotive while in their charge: Do not put it all up to the boilermaker, let the other fellow do his part.

REAMING TAPERED HOLES TO STANDARD SIZES

It is often desirable to ream tapered holes to a standard size, as for instance on the piston rod fit in air compressor piston heads. Where an ordinary reamer is used there is certain to be considerable variation in the sizes of the holes, unless the taper is very small. To overcome this difficulty the type of reamer shown below has developed in the Bloomington shops of the Chicago & Alton.

The body of the reamer has a threaded portion between

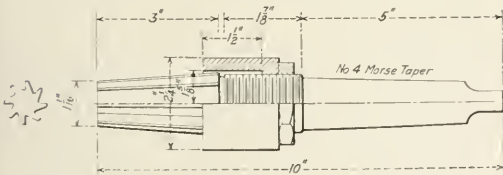

A Reamer Which is Handy for Duplicating Tapered Holes

the flutes and the shank. Fitting over the threaded portion of the body is a stop, which is movable but can be held at any desired point by a lock nut. The stop is adjusted so that it comes in contact with the work when the hole has been reamed to the proper dimensions. Any number of holes can be reamed without the least variation in the size. When it becomes necessary to sharpen the reamer, the stop can be removed. By means of a plug gage or caliper, the original setting can readily be duplicated.

HOME MADE PIPE BENDER

A pneumatic pipe bender with several novel features is in use in the car department of the Danville shops of the Chicago & Eastern Illinois. The device, which is shown in the illustration, bends pipes to any angle desired without heating and without the use of springs or sand to prevent kinks. Three bends can be made at one time on certain classes of

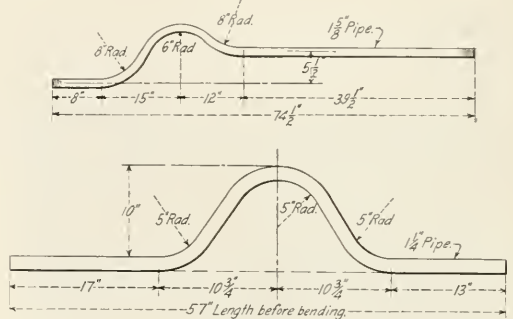

Parts Formed in One Operation on Pneumatic Pipe Bender

work, as for instance in forming the offset in the train line to pass over the Cardwell draft gear spring.

The device consists of a 14-in. air cylinder, the piston of which extends out over a heavy iron plate. The piston is arranged to carry grooved dies of various sizes and the plates carry three grooved rollers, set on studs, which can be shifted to various positions. At one side of the plate is a movable arm which carries a fourth roller mounted on an

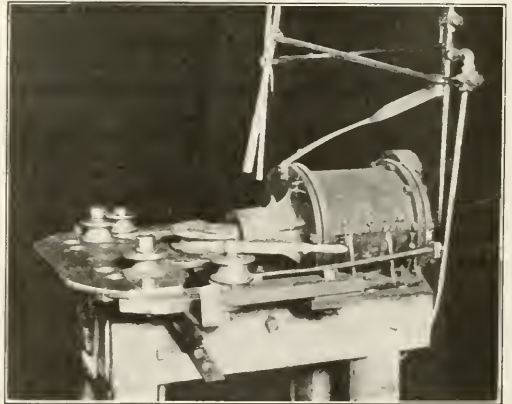

A Pipe Bender Designed for Car Work

eccentric. This can be brought into position by a short handle and is spaced so that when a straight piece of pipe is placed between the two sets of rollers, the eccentric will hold it firmly in place. A movable stop is provided, in line with the roller, so that in making duplicate parts the bends can be located in the proper place. The table is marked to indicate the angle of the bend, which can also be judged by the travel of the piston.

In making single bends only two of the rollers are used. To form offsets as in the train line pipes shown below, the pipe is held by the four rolls and the offset is formed in a single operation. Having the bends all made with the pipe

horizontal has been found a great advantage in working with long pipes. This bender is adapted for a large variety of work and has been found to be well suited for producing parts in quantities as well as for general repair jobs.

"DON'TS" FOR APPRENTICES AND OTHERS

BY HENRY GARDNER

Don't "monkey" with a machine "just for fun," as a machine will not take a joke, and you will be punished every time.

Don't try to operate a machine for the first time without receiving full instructions from some one in authority.

Don't shift heavy belts by hand unless you are an expert, and then great care should be taken not to get caught.

Don't wear shoes that are so worn out that a splinter or nail will go up through the sole and cause a serious injury.

Don't wear ragged, loose sleeves when running machines, as the ends are likely to be caught somewhere, and you will lose a finger or two.

Don't chip toward any one without a screen between you.

Don't stop a planer by half shifting the reversing belt; always stop it by the countershaft.

Don't lean against a machine that is running, and it is better to keep a safe distance from any mechanism in motion or likely to be set in motion. Never ride a planer table.

Don't use the emery wheel without wearing the goggles provided by the company.

Don't touch the teeth of a moving gear or cutter.

Don't set a lathe or planer tool when the work is in motion.

Do not allow a tool to run by the work so far as to cut into a lathe spindle. A machine looks strong, but it can be very quickly and easily injured.

Don't score a planer bed or make holes in a drill table.

Don't lay a long file or any tool on the ways of a lathe; don't cut into a lathe arbor.

The running part of a machine should be oiled every day, and sometimes oftener. If you take a machine that some one else has just been running, don't trust that it has been oiled that day; oil it yourself, but stop it first.

Don't waste oil by pouring it on so that the greater part runs away; the company loses a great deal of money through the careless use of oil; a drop in the right place does more good than a cupful on the floor.

Don't be afraid of soiling your hands, as it is impossible to work in a railroad shop and keep your hands white and smooth. Don't wear gloves except for the roughest work and never when running machines.

Don't get your suit of overalls covered with grease and dirt; with a little care you can keep much cleaner than you think. A dirty suit doesn't always mean that you have done a lot of hard work; it more often indicates a careless, untidy disposition.

Don't put your tools where you can't find them easily; "have a place for everything and everything in its place."

Don't let files destroy one another by throwing them together in the drawer. Don't use a monkey wrench for a hammer.

Don't put finished work in a vise without using copper or lead jaws.

Don't swing a sledge or hammer that you know is working loose on the handle, thinking that it won't come off 'til next time; you may not get hurt, but what about the other fellow?

Don't strike highly tempered steel with a hammer; many eyes are destroyed from this cause alone.

Don't do a bad job; any man to whom a bad job is not a lasting mortification shows himself lacking in self-respect. A long job may soon be forgotten, a bad one never.

Don't go over your foreman's head with your grievances,

as the man you go to will send you back to the foreman and give you no satisfaction; moreover, the foreman will never forget it.

Don't have a grouch. Be cheerful and willing at all times. Smile once in a while.

Don't borrow tools and forget to return them; it is best not to borrow tools at all.

Don't forget that you are an inexperienced young man, learning a trade, and that every one in the shop can teach you something, and there is an easy way to get this knowledge; simply be respectful and they will help you.

Don't forget that although you are drawing wages, you are costing the company some money for the training they are giving you. You have spoiled work and thrown it in the scrap pile, and you may have broken valuable tools, and possibly you have injured some expensive machine.

Don't get excited and cross over little things. Many a man has lost splendid opportunities by letting his temper run away with him.

Don't spend your entire life in the shop and don't talk too much shop outside of working hours. All your leisure time (except that spent in study) should be given up to rest and wholesome recreation.

Don't worry about your work; if you have made a mistake and spoiled a piece of work, don't be afraid of what the boss will say; take what he has to say and don't do it again.

Don't think that you are so important that the company can't get along without you; there is always some one waiting to take your place and do your work as well or perhaps better than you did.

Don't be afraid to work a few minutes overtime without pay; no matter what the foolish ones say, you will make an impression on the boss, which may put you ahead of them all some day.

Don't spend your money foolishly. Save a little if you can. Start a bank account, if only a very small one.

Don't be too thin-skinned and touchy; many a competent young man has taken off his overalls and quit because he couldn't stand the jokes of the shop men or some hasty order or censure given him by a busy foreman.

Finally, don't forget that there is always room at the top. Keep striving for that goal, as no one knows just when he will arrive there. Keep plugging away every day doing your best, and time will tell. If you are not kept in the service after serving your time, there is generally a good reason, and nine times out of ten you will guess the reason without any one telling you.

LUBRICATING OIL DENSITY*

BY W. F. SCHARHORST

The importance of the specific gravity or density of oil as a measure of its lubricating properties is much overestimated because no evidence is given of the actual constituents. On the other hand, the specific gravity test is of considerable value in identifying oils. For example, if a certain oil is giving satisfaction its density may be determined and compared with that of any oil claiming to be the same, thus giving a check on the claim. Density or specific gravity of a liquid is usually measured by means of an hydrometer, and one of the arbitrary scales used with the hydrometer is the Beaumé scale. As lubricating oil is used by many people who do not understand the Beaumé scale and the hydrometer, it is the purpose of this article to give a brief illustration of their use and also a simple method of determining specific gravity, in case the hydrometer is not available.

When the statement is made that an oil has a specific gravity of X deg. Beaumé, it is simply necessary to add X to 130 and divide the sum into 140, which gives the density. This

*Copyright by W. F. Scharhorst.

result is obtained by use of the following formula, as taken from Kent:

$$\text{Sp. Gr. (light liquids)} = 140 \div (130 + \text{deg. Beaumé}).$$

To find how this formula works out in a particular case, consider the following problem: What is the density of a 31 deg. Beaumé oil? Specific gravity = $140 \div (130 + 31) = 140 \div 161 = .87$. It is evident that an oil whose density is 10 deg. Beaumé is just as heavy as water, because $140 \div (130 + 10) = 1$.

In case no hydrometer is available for the determination of the specific gravity, the following method may be used, and the only apparatus necessary is a clean jug and an accurate weighing instrument: Let

- A = the weight of a clean empty jug.
- B = its weight when filled with water.
- C = its weight when filled with oil.

The specific gravity can then be determined by the use of this simple formula:

$$\text{Specific gravity} = \frac{C - A}{B - A}$$

This amounts to dividing the weight of a certain volume of oil by the weight of the same volume of water, which accords with the definition of specific gravity. The temperature of the water, oil and jug should all be the same throughout the test, and if possible maintained at 60 deg. F., which is the standard.

SIDE ROD STRAPS

For a shop equipped with an acetylene welding outfit, the Lehigh & Hudson practice in making side rod straps, at Warwick, N. Y., is of interest, especially in case the blacksmith shop is overcrowded with work, or is not equipped with a power hammer sufficiently heavy to forge the straps. The method involved consists in laying out two straps

so that they may be machined on the slotter, as shown in Fig. 2. It is believed that a rod strap cut out in this way with the acetylene torch is equal to, if not better than a forged strap, and is just as easy to machine.

If the prints call for a solid grease cup on the strap, a threaded bushing is applied by electric welding, which gives a quick and satisfactory job. In fact, this is the best way to apply a grease cup even in the case of a forged strap, there being a considerable saving over the old way of forging a lump of steel on the strap, to be later machined to make the cup.

In regard to the relative cost of a forged strap and one which has been cut out with the acetylene torch, it is believed



Fig. 1—Straps Ready to be Cut Out with the Torch

on a bar of hammered steel of the correct width and thickness, as shown in Fig. 1. The legs of the straps are laid out toward each other, so that they may be cut out with the acetylene torch, leaving the center in one piece to be later forged into a drawbar. Enough stock is left on the straps

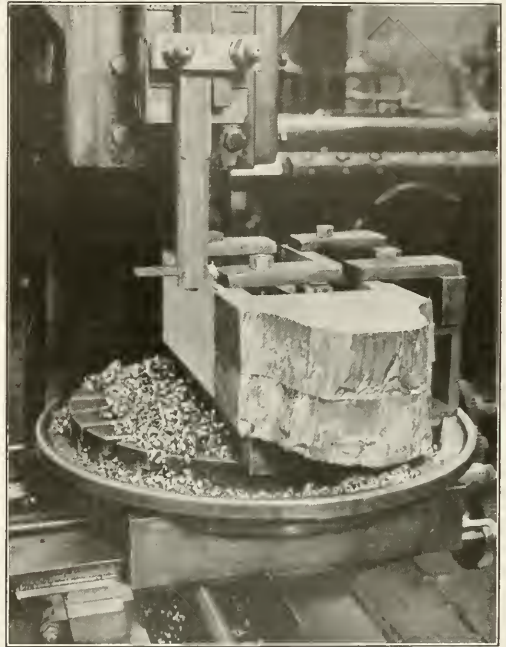

Fig. 2—Straps are Machined in Pairs on a Slotter

that the latter method will result in a material saving. In the case of the middle connection side rod strap illustrated, the cost of material and cutting complete was \$30.35 per strap, which would be reduced considerably if it had not been necessary to buy the original bar of hammered steel from the manufacturer on account of insufficient hammer equipment to forge it in the local shop. The price, \$30.35, does not include the cost of machining, but when it is considered that the builders charge \$160 for a new strap, the total saving will be evident. It has proved economical to cut out the straps and make them in this way, even at the high cost of hammered steel purchased, and the saving would be relatively greater in the case of a shop equipped to draw out their own steel billets.

BRITISH CAR REPAIR PROBLEMS.—Considerable delay has occurred in the repair of British freight cars, and there is a serious congestion. The Railway Executive Committee appealed to the car repairing companies to take steps to deal with the difficult position. Recognizing the necessity for immediate action, it has been decided to form a new company, which will take over the freight car repairing business.



NEW DEVICES

POWER HAMMER ATTACHMENT

The new taper gib and face plate attachment illustrated is used on the Fairbanks power hammer manufactured by the United Hammer Company, Oliver Building, Boston, Mass., and the object of the attachment is to provide a quick and effective means of taking up slack as the hammer becomes worn in service.

Different kinds of dies are furnished, depending on the kind of work it is desired to do and the lower die is fastened to the base of the hammer by a tongue and groove arrangement and a suitable taper key. The upper die shown in the illustration and marked *A* is fastened by the same means to the ram.

The ram is held in place by the face plate *B* and the taper gib *C*. It is provided with two opposite vertical ribs, one of which fits in a groove in the body of the hammer and the other in a groove in the taper gib. The motion of the ram up and down is controlled by these two ribs as they slide in their respective grooves. As is usual in the

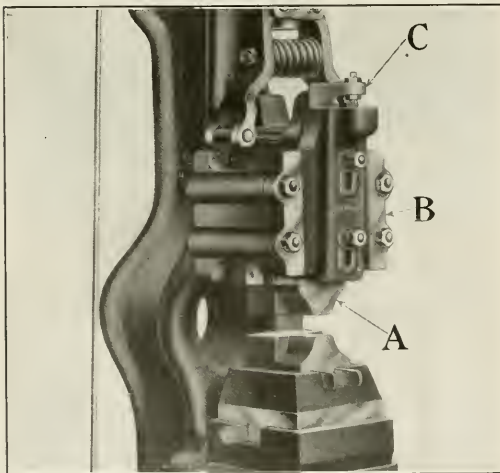

Power Hammer Attachment for Taking Up Wear

case of the smaller power hammers the operation is controlled by a foot pedal.

It will be noted that two studs project through the center of the face plate *B*, the other ends being made into the taper gib. When, on account of excessive wear, it becomes necessary to take up the slack in the ram, the nuts on these two studs are loosened and the taper gib forced down by means of the adjusting screw shown at the top. When the slack has been all taken up the nuts on the two studs are

again tightened, which holds the gib firmly in position.

By the use of a taper gib and a face plate attachment as described, it is possible to maintain just the right amount of play between the ram and its guides and this assures better work and a longer life for the hammer.

ROD LUBRICATION

The lubrication of the heavy side rods and main rods of locomotives is a problem of considerable importance in railroad service. Not only is it important from the standpoint of hot bearings, but the lubrication must be as nearly perfect as possible to reduce the wearing of rod brasses to a minimum,

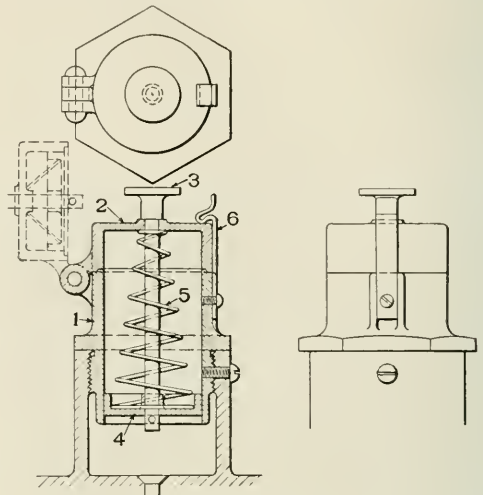

Automatic Hard Grease Cup

and thus keep the slop out of the rods due to loose bearings on the crank pins.

While some roads still use oil cups for lubricating the rods, most of them have adopted a grease cup. The cup commonly used consists of a bushing which fits into the lug on the rod, on a line with the bearing. Through this bushing a malleable iron plug is screwed which forces down the grease into the bearing, the plug being turned down by the use of a wrench. This is not only a tedious method, but also a rather indefinite one, and it requires a man to be continually using a wrench in order to keep the rods properly lubricated.

Another bad feature of the screw plugs is the fact that they become loose, due to the jars and centrifugal force exerted in the rods, thousands of plugs being lost during a year of service on a single road.

The grease cup illustrated works automatically, the only requirement being that it shall be kept filled with grease. It can be applied readily to rods which have been equipped with a screw plug, as the threaded portion is of the same size as the cap for the screw plug.

The cup consists of a body 1 which screws into the rod, a hinged cover 2, through which a plunger 4 and telltale 3 is passed, and is forced down on the grease by spring 5.

The main advantages of this form of a grease cup are that it works automatically and the handle at the top tells the engineer at a glance just how much grease is left in the cup. As a safety measure, the plunger is not allowed to go all the way to the bottom of the cup, a cavity being left which holds a small amount of grease to fall back on in case the cup is not filled immediately, thus preventing a hot bearing. Another advantage is that it is entirely enclosed, so that no grit or dirt can become mixed with the grease, which would tend to wear the bearings. All parts are securely riveted so that they cannot become lost or removed without cause. The cap is held down securely by means of the spring clip No. 6.

When the cup is to be filled, the plunger is pulled up within the cover by means of handle 3, and held while grease is being applied. When the cover is closed the plunger is automatically released, and the pressure transferred to the grease. The spring is of such a tension as to give the required pressure for feeding grease to the bearing.

This grease cup was designed and patented by G. E. Baldwin, mechanical engineer for the Bell Locomotive Works, located at Lincoln, N. J.

TREATED CANVAS ROOFING FOR STEEL PASSENGER CARS

Considerable difficulty has been experienced in the maintenance of the roofs on steel passenger equipment where steel has been used throughout in the construction. Owing to the action of cinders along the top of the cars there is great difficulty in keeping the steel properly covered with a protective coat of paint. As soon as the paint covering becomes broken or cracked, deterioration of the steel plates begins

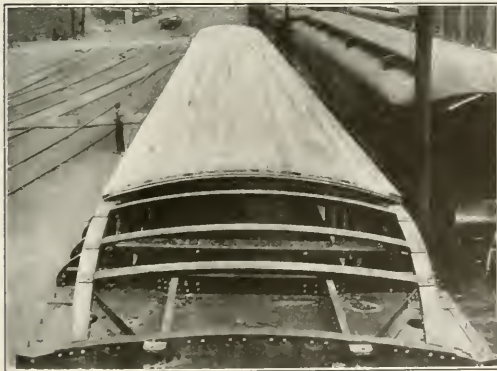

Type of Passenger Car Roof Construction Using Wood Sheathing and Treated Canvas Covering

and proceeds rapidly, especially where the joints in the roof plates project above the smooth surface of the roof, due to the formation of sulphuric acid from the action of water on the cinders. It is also a fact that no matter how stiff the construction of a car may be, there is always more or less weaving of the roof, which is evidenced by the condition of the joints in the sheets after they have been in service for some time.

A special type of canvas roofing, the material of which is impregnated with a treatment making it both waterproof and proof against mildew, has been furnished for several years past by the Tuco Products Corporation, 30 Church street, New York, and much of this material is now in use on wood passenger equipment. In the application of this material the use of white lead is unnecessary, thereby effecting a saving of labor and material. Otherwise the same practice is followed as with any other canvas roofing, the special advantage being that should the protecting film of paint become cracked, thereby permitting moisture to come directly in contact with the material, it does not deteriorate from mildew as is the case with untreated canvas. Within the past few years a number of railways have adopted a semi-wood roof construction in order to secure the advantages of this type of roof covering, which has demonstrated its advantages through many years of service on wooden equipment.

A type of wood roof construction for steel equipment is shown in the illustration. The tongued and grooved wood sheathing is applied directly to furring strips bolted to the steel carlines and projecting slightly above their upper surfaces. Intermediate wood carlines are placed between the steel carlines to provide additional nailing strips for the sheathing. The Tuco Standard car roofing is then applied to the sheathing in the usual manner. This construction provides its own insulation, a considerable saving in itself, and also eliminates the troubles with the joints of the metal roof, due to the weaving action and the rapid deterioration of the projecting surfaces, caused by the impinging action of the cinders and corrosion. There are now a large number of steel passenger cars on which this or a similar type of roof construction and Tuco Standard roofing has been used.

The treated canvas roofing when properly applied and well sanded is fireproof, and serves all the purposes of the steel roof. In addition its life is much greater than that of the steel. Cars with roofs covered with this material are now in service with the roofs in good condition after ten years' service. The material is furnished in three weights, designated as "CC," "AA" and "FF," which correspond to No. 4, No. 6 and No. 8 duck, respectively.

HORIZONTAL BENCH MILLER

The machine illustrated, known as the No. 1 horizontal bench miller, is made by the Bickett Machine & Manufacturing Company, Cincinnati, Ohio. It is especially designed with a view to economical production and the highest possible quality and quantity of output. It is a handy, all-around jobbing machine and, as is often necessary in railway tool rooms, will do both light and fairly heavy work to good advantage. It is well adapted for such operations as end milling, keyseating, oil grooving, face milling, splining, "T" slotting, gear cutting and straddle milling. Many similar operations can be performed on this machine with greater speed and precision than on the average milling machine.

The machine is arranged for both power and hand feed and may be mounted on a bench or a pedestal. With the power feed on, the movement is transmitted through a series of worms and worm gears that gives it the steadiness and strength of a screw feed. The low cost of the machine and the small amount of floor space and motive power required make it a convenient addition to any tool room.

The different parts of the Bickett miller are designed and made with especial care, the spindle being of crucible steel, accurately ground and mounted on Gurney ball bearings. It is provided with a means of compensation for wear. This spindle has six possible speeds and will safely run at 2,500 r. p. m. continuous operation.

The arbor is made of tool steel accurately ground all

over and is fitted with a set of cast iron spacing collars $1\frac{1}{2}$ in. in diameter and an arbor support bearing bushing. Both arbor and collars are keyseated. The arbor support arm is made of solid steel, 1-15/16 in. in diameter, turned and ground all over and is provided with a solid cast iron arbor support bracket. This bracket is fitted with a bushed center bearing and also a regular pointed center, either of which can be used for supporting the cutter arbor. The maximum distance from the face of the column to the bracket is $11\frac{1}{2}$ in.

A three-step cone pulley is provided as shown on the illustration and the driving belt should be 2 in. wide. The table is 24 in. long by $5\frac{1}{2}$ in. wide and is unusually thick so as to withstand the strain when clamping on the work. There is a "T" slot $\frac{1}{2}$ in. wide running from end to end and the table is provided with oil grooves on both sides and an oil pocket on each end.

As stated before, the machine is arranged for both power and hand feed, the power feed mechanism being arranged to give .003 in., .006 in., .009 in., and .012 in. longitudinal travel of the table per revolution of the spindle. It is driven by a 1-in. leather belt, which transmits the power through a four-speed gear box and a universal drive shaft to a worm and gear under the table. An automatic trip releases this worm at the end of the cut.

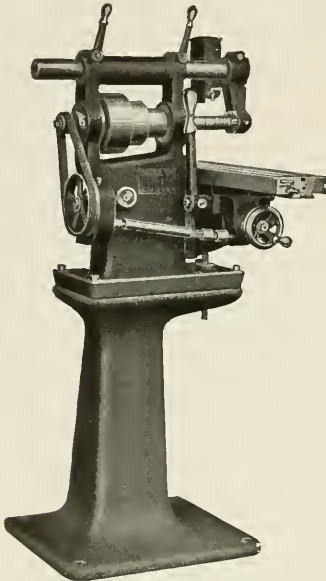

The Bickett Horizontal Bench Miller

The gears are thoroughly guarded to prevent accidents. The power feed can be changed to hand feed at will, the hand feed being arranged to operate either by means of a geared lever or handwheel.

The screw elevating knee is of the box type, carefully scraped and alined and is held to the column by a substantial adjustable gib. It is raised and lowered by means of an Acme thread elevating screw. The transverse and vertical feeds are both provided with adjustable dials graduated to read in one-thousandth of an inch.

The regular equipment includes a countershaft fitted with 8-in. tight and loose pulleys and the belts are arranged to run close to each side of the tight pulley, thereby making possible a rapid change from one speed to the other. The special equipment includes a 6-in. plain vise, a $2\frac{1}{2}$ -in.

plain vise, a $2\frac{1}{2}$ -in. swivel vise, a draw-in. attachment, draw-in collets, a pedestal and a Fullo pump and piping. The general dimensions of the machine are $9\frac{1}{2}$ in. by 18 in. by 25 in. high without the pedestal. The capacity of the machine is as follows: Longitudinal feed 16 in., transverse feed 5 in., vertical feed 5 in.

ANGLE AND LEAD TESTING MACHINE FOR THREAD GAGES

In these days of interchangeable machine parts, where gages are playing so important a role, the thread gage is one of the most difficult to make and to measure accurately, and many mechanics who have attempted the job gave it up for several reasons. One was the difficulty in obtaining machinery accurate enough to do the work and another was the lack of facilities for testing thread gages.

During the last two years, however, there has been considerable improvement in the making of thread gages because engineering societies, large munition concerns and large manufacturing concerns realized that the question of screws, taps and tapped holes in work was one of their most difficult problems. In the manufacture of taps, hobs for hobbing dies, male thread gages and hobs for female thread gages, the question of correct lead and correct angle of the thread was found to be more important even than the correct diameter measurement, and the H. E. Harris Engineering Company, Bridgeport, Conn., has recently designed and constructed

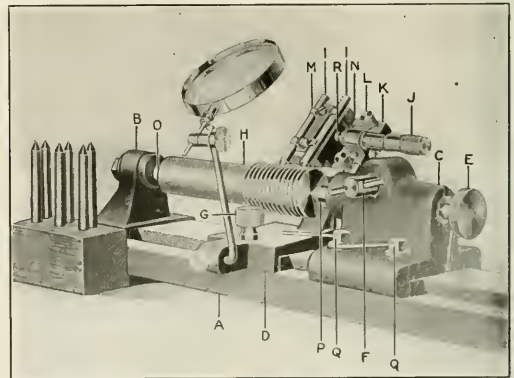

Machine for Testing the Angle and Lead of Screws

machines for testing thread gages which are used successfully in its own shops and by the Bureau of Standards at Washington.

Multiplying gages, even when most carefully made, are prone to inaccuracy due to wear, rust, oil, dirt or other foreign substances, which although infinitesimal in themselves, cause a marked error in reading, due to the multiplying feature. The problem, therefore, was to design a thread gage testing device for the angle and lead which should be rigid and substantial, thoroughly accurate and upon which a very small degree of error might be easily ascertained.

In testing the truth of a flat surface a knife edge straight edge is generally used, as the smallest amount of error, even less than .0001 in. will readily show light between the surface tested and the knife edge, and this principle was embodied in the machine illustrated.

By referring to the illustration which is a general view, it will be noted that the machine consists primarily of a cast iron bed *A*, stationary head *B*, with fixed center *O* and sliding tail block *C*, which carries spring center *P*. The compound slide *D*, very accurately made, is provided with a

micrometer attachment to measure horizontal travel, and the test pieces *I I*, held by a spring clip *M*, are just one inch apart and adjustable in or cut by finger pressure. The set of test pieces shown are ground to different known angles at the point. *H* is a standard thread gage and the magnifying glass is for use on fine work.

Method of testing lead.—If the thread gage is standard one-inch, eight-thread, the test pieces will be found to fit accurately into the thread, but if there is a slight error in the pitch, it is simply necessary to withdraw one test piece *I* and move the slider *N* until the other test piece just fits. The amount the slider is moved, as indicated by the micrometer, shows the lead. The same principle applies to larger or smaller threads and to the English or to the metric systems.

Methods of testing angles.—In testing angles different test pieces may be tried until one is found that fits the thread or if a standard 60 degree test piece is tried, it will show whether the angle is too large or too small, and whether the cutting tool has been set up square or not. Also such defects as, too large a root diameter or too rounded a top to the thread will show up very plainly. In fact the machine provides an accurate check on thread angle and lead and standard shape.

WOOD MILLING MACHINE

A wood milling machine is to the pattern shop what a universal milling machine is to the tool room. It greatly increases the range of machine operations, thereby eliminating much hand work and resulting in greater accuracy, increased production and greater ease in making duplicate parts. Almost an infinite variety of operations can be performed from cross grooving, trenching and jointing to moiding, mortising and gear cutting.

The wood milling machine illustrated is an improved tool recently placed on the market by the Oliver Machinery Company, Grand Rapids, Mich., and several features make it especially adaptable to railway pattern shop practice. It is made in two sizes, the No. 75 being intended for smaller work and the No. 102 being designed for large shops and heavier work. Referring to the illustration, it will be noticed that the column broadens out rapidly as it nears the large base to which it is bolted, and this insures a substantial machine, practically free from vibration. The knee is of the box type, closed on top to prevent chips interfering with the raising mechanism and open below.

It has a 21-in. travel on the vertical ways and is easily moved by the large hand wheel and square threaded screw.

The table is tapped at convenient locations for attaching the general purpose clamps, and will rotate in a horizontal plane while tipped at any angle up to 45 deg. A positive centering device locates the center directly over the ball bearing swivel center for circular work. The compound cross slides are above the double swivel and tilting mechanism so that the slides operate with the table in any position.

The vertical and horizontal spindles are 1/8 in. in diameter, made of high grade stock accurately ground and supported on ball bearings. The allowable maximum speed is 5,000 r.p.m., and regular speeds usually vary from 1,200 to 4,500 r.p.m. The capacity of the machine is limited only by the size of cutters that can safely be used and the ability of the operator to get the full usefulness out of the machine. Using the vertical spindle, circular work up to 19 in. in diameter may be turned by means of the revolving table. By using the horizontal spindle and revolving

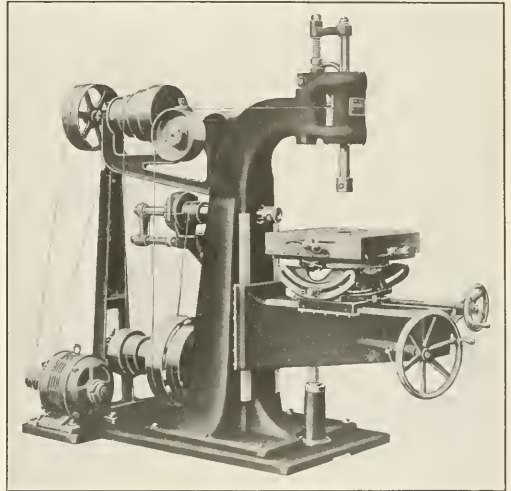

Oliver No. 75 Wood Milling Machine

table, work up to 48 in. in diameter may be turned. A special dividing head permits spur and bevel gears to be accurately cut up to 24 in. in diameter with a 4-in. face. The countershaft runs in babbitt bearings and is an integral part of the machine, being solidly supported from the column and base plate. The countershaft speed is 500 r.p.m. and a 5-hp. motor is recommended for the heavier work. The machine may be driven by a variable or constant speed motor or from line shafting if desired.

A large part of the value of the machine depends upon having a complete assortment of cutters, and an operator who understands how to adjust them quickly and to the best advantage. The company furnishes with the machine an extensive assortment of these cutters for all kinds of ordinary work, and is prepared to make any special cutters that may be required.



Copied from International Film Service

A Battery of Big Guns Mounted on Special Railway Carriages

Railway Mechanical Engineer

(Formerly the RAILWAY AGE GAZETTE, MECHANICAL EDITION
with which the AMERICAN ENGINEER was incorporated)

PUBLISHED ON THE FIRST THURSDAY OF EVERY MONTH BY THE
SIMMONS-BOARDMAN PUBLISHING COMPANY

EDWARD A. SIMMONS, *President* L. B. SHERMAN, *Vice-President*
HENRY LEE, *Vice-President and Treasurer* M. H. WIUM, *Secretary*
WOOLWORTH BUILDING, NEW YORK, N. Y.
F. H. THOMPSON, *Business Manager*, CHICAGO.

Chicago: Transportation Bldg. Cleveland: Citizens' Bldg.
Washington: Home Life Bldg.
London: Queen Anne's Chambers, Westminster.

ROY V. WRIGHT, *Editor*
R. E. THAYER, *Managing Editor*

C. B. PECK, *Associate Editor* E. L. WOODWARD, *Associate Editor*
A. F. STUBRING, *Associate Editor* C. W. FOSS, *Associate Editor*

Entered at the Post Office at New York, N. Y., as mail matter of the second class.

Subscriptions, including the eight daily editions of the *Railway Age* published in June in connection with the annual convention of the Master Car Builders' and American Railway Master Mechanics' Association, payable in advance and postage free: United States, Canada and Mexico, \$2.00 a year; Foreign Countries (excepting daily editions), \$3.00 a year; Single Copy, 20 cents.

WE GUARANTEE, that of this issue 6,800 copies were printed; that of these 6,800 copies 5,603 were mailed to regular paid subscribers, 128 were provided for counter and news companies' sales, 346 were mailed to advertisers, 167 were mailed to exchanges and correspondents, and 556 were provided for new subscriptions, samples, copies lost in the mail and office use; that the total copies printed this year to date were 39,400, an average of 7,880 copies a month.

The RAILWAY MECHANICAL ENGINEER is a member of the Associated Business Papers (A. B. P.) and of the Audit Bureau of Circulations (A. B. C.).

The output of repaired freight cars at the Kent (Ohio) shops of the Erie was \$70 for the month of March, compared with 424 in March, 1917, an increase of over 100 per cent.

Three fires, starting simultaneously in the Lake Erie & Western shops at Lima, Ohio, on April 24, virtually destroyed the \$500,000 plant. From 10 to 14 locomotives, a new train of troop coaches just completed in the shops, and many other coaches and box cars were destroyed.

The United States War Department has ordered for use in France 80 light locomotives, 60-centimeter gage, weighing 35,000 lb., from the Davenport Locomotive Works, also sixty-seven 50-hp. and seventy 35-hp. gasoline locomotives from the George P. Whitcomb Company.

"Get together" meetings are being held in the shops along the entire Erie system in an endeavor to obtain greater co-operation and quick, accurate work in the shops, that the Erie may do its utmost in helping to win the war. Such a meeting was recently held at the Susquehanna shops and several officers of the company, including William Schlafge, general mechanical superintendent, addressed the meeting, urging the men to give their best service.

Government Orders for Locomotives and Freight Cars

After three weeks of conferences regarding the priority to be given the various activities of the government as to their requirements for steel, an agreement was reached at a conference on April 19 between representatives of the War Industries Board, the Shipping Board and the Railroad Administration, by which the Shipping Board, the Army and the Navy will have priority over the railroads. The Railroad Administration was assured the steel required for the construction of the 2,000 locomotives proposed to be ordered, and for the 100,000 cars, but the car program was required to be changed so as to reduce the quantity of material and especially of steel plates that would be needed.

As a result the all-steel box cars, for which standard specifications were recently adopted, will not be built at this time and less steel than was originally planned for will be used in other types of cars. For example, the 55-ton hopper car will probably be built with wooden sides.

The Railroad Administration has already awarded contracts for 30,000 steel underframe box and coal cars to the American Car & Foundry Company, involving an ag-

gregate outlay of between \$80,000,000 and \$90,000,000 on the basis of cost plus five per cent. Negotiations for 70,000 additional cars are still pending. It is reported that orders have also been placed for about 1,000 locomotives of the standard types.

It is planned to place orders for approximately 100,000 additional cars in about six months.

Women in Railroad Service

The Pennsylvania Railroad now has in its service 6,513 women, an increase of more than 5,000 since May 1, 1917. The number of females in each of several occupations is given as follows:

Clerks and stenographers.....	3,551	Mechanics' helpers	5
Telephone operators	778	Painters	4
Track laborers	293	Hammer operators	6
Messengers and assistant mes-		Turntable operators	2
sengers	192	Power operators (electrical)...	7
Typists	121	Fuel inspector	1
Machine hands	29		
Drattswomen	20	Total	5,009

The number of women now employed on prominent English roads is given in a recent statement as follows:

London & Northwestern.....	8,392	Northeastern	8,520
Great Western	6,174	Great Central	3,200
Midland	9,000	Glasgow & Southwestern.....	1,202

The Midland has increased its forces by 2,700 since last July. Over 1,000 of the women on the Northeastern are employed in the shops, making shells.

Questionnaire on Equipment Construction and Repair

At the request of the Director General of Railroads the Interstate Commerce Commission has addressed to the railroads a questionnaire asking for complete detailed information relating to repairs to and construction of equipment. Roads are asked to report whether their present shop facilities permit, in addition to properly making all necessary repairs to the present equipment, the construction of new locomotives, freight cars and passenger cars, whether they own or operate under subsidiary companies shops at which locomotives or cars are built or repaired, together with the normal monthly capacity of such shops and the period for which the capacity is engaged on work now in hand or authorized. Information is also desired as to whether it has been the practice to build any portion of the new equipment necessary to replace destroyed or retired locomotives or cars, the present monthly capacity of the shops for the construction

of new equipment by classes, whether all necessary current repairs are made at company shops or by other railroads or at other than railroad shops. If such repairs have been made by other railroads during the past three years information is desired as to the terms under which the work was done. If they have been made by contractors information is requested as to the names of the contractors, the amount of work done and the detailed costs. If the repairs have been performed under express contracts complete information is asked regarding the contracts, prices of materials, labor costs, supervision of work performed, etc., which affect the aggregate costs of the work and will enable a comparison to be made with ordinary railroad shop operations, for the purpose of indicating economy on such repair work. Information is also asked as to repairs made for other railroads.

Circulars Issued by the M. C. B. Association

Circulars No. 28 to 33 inclusive, were issued on March 20, by the executive committee of the Master Car Builders' Association.

Circular No. 28 calls attention to the absolute necessity of having all cars equipped with safety appliances by September 1, 1919, and points out that in order to accomplish this it will be necessary and advisable to equip empty foreign cars when passing over the regular freight car repair tracks. The equipment can thus be applied without undue detention to the car. Under the provisions of Rule 33, the repairing line may be reimbursed for the expense of equipping cars with these appliances.

Attention is called in Circular No. 30 to the necessity from the standpoint of safety, that all axles purchased should conform fully to the standards of the association. Axles are being made and offered to railroads which do not conform to the M. C. B. standards. They are made full at the center and hub, but between these two points are under standard size. The circular contains an illustration of the axle in question, that of 100,000 lb. capacity, showing in broken lines the outline of the rough forged axles which are being offered.

In circular No. 32 is announced an extension of the date after which the requirements for the adjustment of hand brake power on tank cars, set forth in circular No. 22, become effective. The extensions are: (1) On new equipment built after July 1, 1918; (2) on existing equipment by January 1, 1921.

More Acknowledgments of Tobacco Shipments

Samuel O. Dunn, secretary of the Railway Regiment's Tobacco Fund, has received a letter from R. L. James, first lieutenant and acting adjutant of the Seventeenth Engineers (Railway) Regiment, now in France, dated March 16, acknowledging receipt of a shipment of tobacco which has been distributed among the men. He said in part: "We appreciate very much the kindness of the different railroad organizations who are participating in making these tobacco shipments to the railroad men here in France. The supply of tobacco in France is limited, and for that reason all tobacco received is all the more acceptable. We all thank you very much."

A letter has also been received from Morton Russell, captain adjutant of the Eighteenth Engineers (Railway) Regiment, written by order of Colonel Cavanaugh, acknowledging receipt of three cases which contained twelve 20-lb. packages of tobacco, which have been distributed to the regiment; and expressing the appreciation of the men in that unit.

F. A. Poor, chairman of the Railway Regiments' Tobacco Fund, Chicago, has received acknowledgments of the receipt of shipments of tobacco from three railway regiments in France. Ernest Graves, lieutenant colonel of the Fifteenth

Regiment, U. S. Engineers, writes under date of March 16, that two shipments of tobacco have been received in good condition and distributed to the men. The first shipment contained 240 lb. of Bull Durham and 5 lb. of Tuxedo smoking tobacco and the second shipment contained 540 lb. of Bull Durham and 15 lb. of Lucky Strike. He stated that "There is no doubt but that the men greatly appreciated both shipments."

H. Burgess, colonel of the Sixteenth Engineers Railway Regiment, has written under date of March 12 that the shipment made on December 16 finally reached them although it arrived and was put into the warehouse just a few hours before the latter burned. "The result was that our tobacco was burnt in a fashion different from that intended. One case, however, was rescued and distributed, and all the men very much appreciate the gift."

H. H. Maxfield, lieutenant colonel, commanding the Nineteenth Engineers, Railway Regiment, wrote on March 16 to acknowledge receipt of a shipment of tobacco and stated "The men appreciate this tobacco a great deal more than might be expected, since American troops are entirely dependent upon supplies sent from the States."

MEETINGS AND CONVENTIONS

International Railway Supply Men's Association.—At a recent meeting of the association at the Hotel Sherman, Chicago, resolutions were passed suspending dues for the year 1918. This action was taken following a request by the International Railway Fuel Association that no exhibit be held at the coming convention of that organization. All entertainment features by the supply association will also be dispensed with.

Air Brake Association.—The 25th annual convention of this association will be held in Cleveland, Ohio, May 7 to 10, with headquarters at the Hotel Winton. The work of the convention this year will be directed especially toward greater safety of train movement, less expense of maintenance, and more efficient inspection, with a particular effort to put air brakes in a condition to help the roads through the coming severe winter campaign. The important papers to be presented are as follows: What is the Safe Life of an Air Brake Hose? Recommended Practice of the Air Brake Association, and Conditioning Air Brakes on Freight Trains to Prevent Troubles Enroute.

Machinery and Tool Convention.—The enormous problem of manufacturing and supplying machinery and tools sufficient for the carrying out of the government program for the production of ships, shells, guns and aircraft will be the subject considered at the great "War Convention" of the machinery, tool and supply industry of the country to be held in Cleveland the week of May 13. One thousand men who are bearing the brunt of the unprecedented demand for machinery will gather from all parts of the country to lay out a plan, with the aid of government officials, to keep the great munition program going at top speed. The big war convention will be a joint meeting of four great national associations, the American Supply & Machinery Manufacturers' Association, the National Supply & Machinery Dealers' Association, the Southern Supply & Machinery Dealers' Association and the National Pipe & Supplies Association, which will meet together in order to co-ordinate their efforts toward one goal, "More Ships, More Shells."

International Railway General Foremen's Association.—It has again been decided by the executive committee of this association to postpone the annual convention. This action was taken in consideration of the great demand for locomotives and cars and the need under present conditions of constant and increased supervision in the railroad

shops. It is the intention to publish the year book, in order to maintain the continuity of the proceedings of the association. The following topics have been selected for the year and the members are requested to write their opinions on the subjects and send them to the secretary. Topic No. 1—What effect has the war had upon your shop methods, and what changes for the better are the results thereof? Topic No. 2—The mileage of a locomotive. Its relation to cost of shop and running repairs. Who should determine when to shop an engine and who should furnish work report? Topic No. 3—Economic and necessary electrical equipment for railroad shops and roundhouses. Topic No. 4—Is the flat rate of pay for various classes of labor a success? Should the minimum rate accepted by various organizations be the maximum rate allowed by employers? How best can greater output by unit of labor be obtained? Topic No. 5—How can a uniform classification of repairs to locomotives be brought about?

International Railway Fuel Association.—The 1918 convention of the International Railway Fuel Association will be held in Chicago on May 23 and 24. The program for the convention, as tentatively outlined, is as follows:

Introductory address, E. W. Pratt, president International Railway Fuel Administration.

The Fuel Problem in the War, H. A. Garfield, U. S. Fuel Administrator. The Railroads and their Relation to the Fuel Problem, C. K. Gray, Director Division of Transportation, United States Railroad Administration. What Can be Done for Our Northern Ally, Sir George Bury, chairman, Canadian Railways, War Board.

The Need for Fuel Conservation, P. B. Noyes, Director Conservation Division, U. S. Fuel Administration.

The Coal Operator and His Responsibilities in the Fuel Situation, Edwin Ludlow, vice-president, Lehigh Coal and Navigation Co., Lansford, Penn.

What the Men on the Locomotives Can Do, W. S. Stone, grand chief, Brotherhood of Locomotive Engineers.

What the Coal Miner Can Do to Help the Government, the Railroads and the Men at the Front, John F. White, Labor Advisor, U. S. Fuel Administration.

The Motive Power Department and Fuel Economy, R. Quayle, general superintendent, Motive Power and Car Department, Chicago & North Western.

What the Coal Operator Can Do to Help Win the War, H. N. Taylor, vice-president, Central Coal & Coke Company, Kansas City.

The Railroad Industrial Army a Component Part of the American Expeditionary Force and the Allied Armies, W. S. Carter, Director, Division of Labor, United States Railroad Administration.

The Supply and Distribution of Fuel, J. D. A. Morrow, Director, Distribution Division, U. S. Fuel Administration.

Relation of Locomotive Maintenance to Fuel Economy, Frank McManamy, Director, Division Locomotive Maintenance, United States Railroad Administration.

The Transportation Department and Fuel Economy, E. H. De Groot, Jr., Assistant Manager, Car Service Section, Division of Transportation, U. S. Railroad Administration.

More and Better Coal, Eugene McAuliffe, president, Union Colliery Company, St. Louis.

The following list gives names of secretaries, dates of next or regular meetings and places of meeting of mechanical associations:

- AIR BRAKE ASSOCIATION.—F. M. Nellis, Room 3014, 165 Broadway, New York City. Convention May 7 to 10, 1918, Cleveland, Ohio.
- AMERICAN RAILROAD MASTER TINNERS', COPPERSMITHS' AND PIPEFITTERS' ASSOCIATION.—O. E. Schlink, 485 W. Fifth St., Peru, Ind.
- AMERICAN RAILWAY MASTER MECHANICS' ASSOCIATION.—J. W. Taylor, Karpen Bldg., Chicago.
- AMERICAN RAILWAY TOOL FOREMEN'S ASSOCIATION.—R. D. Fletcher, Belt Railway, Chicago.
- AMERICAN SOCIETY FOR TESTING MATERIALS.—Prof. E. Marburg, University of Pennsylvania, Philadelphia, Pa. Annual meeting June 25-28, 1918, Hotel Travmore, Atlantic City, N. J.
- AMERICAN SOCIETY OF MECHANICAL ENGINEERS.—Calvin W. Rice, 29 W. Thirty-ninth St., New York.
- ASSOCIATION OF RAILWAY ELECTRICAL ENGINEERS.—Joseph A. Andrencetti, C. & N. W., Room 411, C. & N. W. Station, Chicago.
- CAR FOREMEN'S ASSOCIATION OF CHICAGO.—Aron Kline, 841 Lawler Ave., Chicago. Second Monday in month, except June, July and August, Hotel Morrison, Chicago.
- CHIEF INTERCHANGE CAR INSPECTORS' AND CAR FOREMEN'S ASSOCIATION.—W. R. McMunn, New York Central, Albany, N. Y.
- INTERNATIONAL RAILROAD MASTER BLACKSMITHS' ASSOCIATION.—A. L. Woodworth, C. H. & D., Lima, Ohio.
- INTERNATIONAL RAILWAY FUEL ASSOCIATION.—J. G. Crawford, 547 W. Jackson Bldg., Chicago. Convention May 23 and 24, Chicago.
- INTERNATIONAL RAILWAY GENERAL FOREMEN'S ASSOCIATION.—William Hall, 1126 W. Broadway, Winona, Minn.
- MASTER BOILERMAKERS' ASSOCIATION.—Harry D. Vought, 95 Liberty St., New York.
- MASTER CAR BUILDERS' ASSOCIATION.—J. W. Taylor, Karpen Bldg., Chicago.
- MASTER CAR AND LOCOMOTIVE PAINTERS' ASSOCIATION OF U. S. AND CANADA.—A. P. Dunc, B. & M., Reading, Mass.
- NIAGARA FRONTIER CAR MEN'S ASSOCIATION.—George A. J. Hochgrebe, 623 Brisbane Bldg., Buffalo, N. Y. Meetings, third Wednesday in month, Statler Hotel, Buffalo, N. Y.
- RAILWAY STOREKEEPERS' ASSOCIATION.—J. P. Murphy, Box C, Collinwood, Ohio.
- TRAVELING ENGINEERS' ASSOCIATION.—W. O. Thompson, N. Y. C. R. R., Cleveland, Ohio. Next meeting, September 10, 1918, Chicago.

PERSONAL MENTION

GENERAL

W. I. CANTLEY, assistant mechanical engineer of the Lehigh Valley, with office at South Bethlehem, Pa., has been appointed mechanical engineer.

FRANK A. DEWOLFF, master mechanic at the Sagua-la-Grande (Cuba) shops of the Cuban Central, has been appointed assistant superintendent of locomotives, with office at the same place.

H. K. FOX, chief draft-man in the motive power department of the Western Maryland at Hagerstown, Md., has been appointed engineer of tests of the Chicago, Milwaukee & St. Paul, with headquarters at Milwaukee, Wis., succeeding W. T. Bennison, resigned.

G. G. GILPIN, chief draft-man of the mechanical department of the Chicago, Burlington & Quincy, has resigned to accept service with another company.

O. R. HALE, assistant superintendent of locomotives of the Cuban Central with office at Sagua-la-Grande, Cuba, has been appointed superintendent of locomotives, with headquarters at the same place.

H. E. HINES, draftsman in the office of the mechanical engineer, of the Chicago, Burlington & Quincy, has been appointed mechanical engineer of the Colorado & Southern, succeeding E. C. Anderson.

E. E. RAMEY, assistant terminal trainmaster of the Baltimore & Ohio at Philadelphia, Pa., has been appointed superintendent of fuel consumption, succeeding W. L. Robinson.



E. E. Ramey

Mr. Ramey was born on March 27, 1883, in Scott county, Va., and is a graduate of the University of Kentucky, with a degree of M. E. In October, 1904, he became an assistant engineer of dynamometer tests in the railway department of the International Correspondence Schools and was subsequently made superintendent of tests for that company, conducting dynamometer tests on various railroads. From September, 1910, to July, 1911, he acted as assistant engineer of dynamometer tests for the Baltimore & Ohio, the Delaware, Lackawanna & Western, the Canadian Pacific and the Chesapeake & Ohio. In October, 1911, he was assigned to tonnage work on the Baltimore & Ohio, and made special studies and reports to the operating vice-president. From June, 1916, to January, 1917, he was general inspector of maintenance and then was engineer of material conservation to July, 1917, when he was appointed assistant terminal trainmaster at Philadelphia.

E. G. JOHNSON, general master mechanic of the Chicago, Burlington & Quincy, with headquarters at Lincoln, Neb., has been appointed assistant superintendent of motive power at Lincoln, and his former position has been abolished.

T. E. KEYWORTH, superintendent of locomotives on the Cuban Central, with office at Sagua-la-Grande, Cuba, has been appointed assistant general manager with headquarters at the same place.

M. J. POWERS, master mechanic of the Denver & Rio Grande, Colorado lines, with headquarters at Denver, Colo., has been appointed superintendent of motive power of the Colorado Midland, with office at Colorado Springs, Colo.

JOHN L. SMITH, master mechanic of the Pittsburg, Shawmut & Northern, with office at St. Mary's, Pa., has been appointed superintendent of motive power and equipment, and his former position has been abolished.

H. S. WALL, superintendent of shops of the Atchison, Topeka & Santa Fe Coast Lines, at San Bernardino, Cal., has been appointed mechanical superintendent, with headquarters at Los Angeles, Cal., succeeding S. L. Bean, deceased.

W. R. WOOD, mechanical engineer of the Great Northern, St. Paul, Minn., has been appointed mechanical engineer on the staff of Ralph Budd, assistant in charge of capital expenditures to the regional director of western railroads, and is located in Chicago.

W. H. WINTERROWD, whose appointment as chief mechanical engineer of the Canadian Pacific, with headquarters at Montreal, Que., was noted in these columns last month, was born on April 2, 1884, at Hope, Ind. He attended the public schools at Shelbyville, Ind., and graduated in 1907 from Purdue University. In 1905 he was employed for a short time as a blacksmith's helper on the Lake Erie & Western at Lima, Ohio, and in 1906 he was a car and air brake repairman on the Pennsylvania Lines West at Dennison, Ohio. After graduation he became a special apprentice on the Lake Shore & Michigan Southern, and in 1908 he went with the Lake Erie, Alliance & Wheeling as enginehouse foreman at Alliance, Ohio. In 1909 he became night enginehouse foreman of the Lake Shore & Michigan Southern at Youngstown, Ohio, and in 1910 was made roundhouse foreman at Cleveland. Later in the same year he was promoted to assistant to the mechanical engineer of the Lake Shore. Since September, 1912, he has been with the Canadian Pacific at first as mechanical engineer and in May, 1915, was appointed assistant chief mechanical engineer.



W. H. Winterrowd

MASTER MECHANICS AND ROAD FOREMEN OF ENGINES

FLOYD BEATTY has been appointed supervisor of locomotive operation of the Erie, with office at Port Jervis, N. Y.

M. G. BROWN, master mechanic of the Wrightsville & Tennessee, with headquarters at Tennille, Ga., has resigned that position to enter the service of the Georgia, Florida & Alabama, with headquarters at Bainbridge, Ga.

S. C. CARLOUGH has been appointed supervisor of locomotive operation of the Erie, with office at Secaucus, N. J.

J. A. CONLEY, master mechanic of the Atchison, Topeka & Santa Fe at Raton, N. M., has been transferred to the Valley division, with headquarters at Fresno, Cal., succeeding John Pullar, transferred.

EDWARD G. KLEINKAUF, general foreman of the Lehigh Valley at South Easton, Pa., has been promoted to master mechanic at Sayre, Pa., succeeding J. P. Laux. Mr. Kleinkauf was born at Wilkes-Barre, Pa., on April 21, 1874, and received his education in the public schools. Starting in November, 1890, as an engine wiper on the Lehigh Valley, he has since served that road continuously in various capacities, with the exception of a period of time from February, 1902, to May, 1903, when he was employed by the Delaware, Lackawanna & Western as a machinist at Scranton, Pa. In November, 1907, he was appointed annex and enginehouse foreman of the Lehigh Valley at Sayre, Pa.; in September, 1913, general foreman at Hazleton; in December, 1915, enginehouse foreman at South Easton, and in February, 1916, general foreman at that point.

J. P. LAUX, master mechanic of the Lehigh Valley, with office at Sayre, Pa., has been transferred to South Easton, Pa., succeeding D. D. Robertson, resigned.

JOHN PULLAR, master mechanic of the Atchison, Topeka & Santa Fe Coast Lines at Fresno, Cal., has been transferred to the Los Angeles division, with headquarters at San Bernardino, Cal., succeeding A. B. Armstrong.

W. A. RANDOW has been appointed master mechanic of the First division of the Denver & Rio Grande, with headquarters at Pueblo, Colo., with jurisdiction over the entire division, with the exception of Burnham shops, succeeding M. J. Powers, resigned, and the office of assistant master mechanic has been abolished.

A. L. ROBERTS, mechanical engineer of the Lehigh Valley, has been promoted to master mechanic, with office at Wilkes-Barre, Pa., succeeding M. R. Smith, resigned.

SHOP AND ENGINEHOUSE

A. B. ARMSTRONG, master mechanic of the Atchison, Topeka & Santa Fe Coast Lines, at San Bernardino, Cal., has been appointed superintendent of shops, succeeding H. S. Wall, with the same headquarters.

W. M. HARDING has been appointed general foreman of the Cincinnati, New Orleans & Texas Pacific at Oakdale, Tenn., succeeding D. H. Andrews.

G. A. HULLMAN has been appointed shop demonstrator at the Meadville shops of the Erie.

HENRY REIFF has been promoted to machine shop foreman of the Erie at Marion, Ohio, succeeding J. Strawser.

CAR DEPARTMENT

T. J. BELL has been appointed superintendent foreman of the car department of the Erie at Cleveland, Ohio, succeeding G. Egan, resigned.

PURCHASING AND STOREKEEPING

G. H. ROBISON, general storekeeper of the Oregon Short Line, with office at Pocatello, Idaho, has been appointed acting purchasing agent in addition to his duties as general storekeeper, with headquarters at Salt Lake City, Utah, succeeding A. E. Hutchinson, deceased.

COMMISSION APPOINTMENT

GARLAND P. ROBINSON, assistant chief inspector of locomotives for the Interstate Commerce Commission, has been appointed assistant manager of the locomotive section of the Railroad Administration.

SURVEY TRADE NOTES

The Maloney Oil & Manufacturing Company has removed its New York office from 50 Church street to 17 Battery place

The Grip Nut Company moved its offices from the McCormick building, Chicago, to the Railway Exchange building, on May 1.

N. M. Garland, of New York, district manager for the Ohio Brass Company, has been elected a member of the board of directors of that company.

P. L. Maher, business manager of the Eastern Car Company, Limited, of New Glasgow, N. S., has been appointed assistant to the president of the Damascus Brake Beam Company, Cleveland, Ohio. Mr. Maher will specialize on shop operation and efficiency.

Major Warren R. Roberts, Quartermaster's Reserve Corps, president of the Roberts & Schaefer Company, Chicago, has been promoted to lieutenant-colonel. At present he is an executive officer for the constructing branch of the construction division of the United States Army.

The Liberty Car & Equipment Company, 20 West Jackson boulevard, Chicago, has been incorporated with P. H. Joyce as president, and has bought the freight car plant of the Central Locomotive & Car Works, Chicago. The locomotive plant of the latter is being utilized for the manufacture of farm tractors.

Rufus Franklin Emery, secretary and treasurer of the Westinghouse Air Brake Company, died suddenly on April 11, in his office at Wilmerding, Pa. He was born in 1869 at Chatham, Mass., and was educated in the grammar and high schools of his native town. He entered business life at an early age and after service with several business interests in the Pittsburgh district, entered the employ of the Westinghouse Air Brake Company in September, 1892, where he held various positions of trust and responsibility, until 1909 when he was elected secretary and treasurer. At the time of his death, Mr. Emery was an officer and director in a number of business and financial institutions in the Pittsburgh district.

Paul W. Wendt of the P. W. Wendt Company, railway supplies, Chicago, has been appointed assistant production manager in charge of steel, of the Emergency Fleet Corporation, United States Shipping Board, in the Chicago district, comprising Michigan, Indiana, Illinois, Wisconsin, Minnesota and Iowa.

The International Oxygen Company, 115 Broadway, New York, announces the appointment of A. E. Ward as sales manager. Mr. Ward was formerly associated with the Prest-O-Lite Company, and in the course of years of association with the compressed gas industries has gained

recognition as an expert in the industrial applications of oxygen, hydrogen and acetylene.

M. F. Emrich, formerly of the Glidden Company, Cleveland, Ohio, has been appointed assistant general manager for Berry Brothers, Detroit, Mich. Mr. Emrich was with the Glidden Company for 28 years, having filled various positions, from the bottom up to the position of assistant to the president. He began his services with Berry Brothers on April 1.

Clyde P. Benning, assistant to the vice-president of Mudge & Co., Chicago, has been appointed western manager, with office in the Crocker building, San Francisco, Cal., in charge of the business of that company in the Pacific Coast states. Mr. Benning was born in Atchison, Kan., on September 20, 1888, and was educated in the public schools of that city. In 1903 he entered the service of the Missouri Pacific and held positions as messenger in the chief dispatcher's office, telegraph operator and freight office and yard clerk. In 1904 he was employed as time-keeper in the master mechanic's office of this road, remaining in that position until April, 1905, when he entered the Missouri Pacific shops as machinist apprentice, later being promoted to machinist. He left the road in 1910 to accept a position with the Tool & Railway Specialty Company at Atchison, remaining with that concern until December 15, 1914, when he entered the service of Mudge & Co. as shop inspector. He was soon after appointed chief inspector and subsequently held the position of service engineer. In 1916 he was made assistant to the vice-president, which position he held until his appointment as western manager, as noted above.



C. P. Benning



R. F. Emery

The Schroeder Headlight Company, Evansville, Ind., manufacturers of locomotive oil and electric headlights and turbo generators, has been purchased by W. A. Carson, vice-president and general manager of the Evansville (Ind.) Railways, the Owensboro (Ky.) City Railroad and the Henderson (Ky.) Traction Company, and a number of associates, some of them interested with him in the Evansville Railways. A new company known as the Schroeder Headlight & Generator Company has been organized with Mr. Carson as active vice-president and general manager. Mr. Carson has been connected with the Evansville Railways since July, 1908. He was assistant to the general superintendent of the Indianapolis & Cincinnati Traction Company from 1903 to 1906, and assistant general manager of the Indianapolis, Columbus & Southern Traction Company from 1906 to 1908. Since his connection with the Evansville Railways the company has constructed a number of interurban connections and through a syndicate of the officers of that company, of which Mr. Carson was a member, has purchased the city lines of Henderson and Owensboro, Ky. In 1912 a lease was secured on the line of the Illinois Central Railroad between Evansville and Henderson and this property was electrified by the Evansville Railways. A gasoline car ferry was installed to transfer the interurban cars across the river. In 1913 the Crescent Navigation Company was in-

corporated with Mr. Carson as president to operate on the Ohio river in connection with the railway properties. Mr. Carson retains his connection as vice-president and general manager of the Evansville Railways in an advisory capacity and will continue as president of the Crescent Navigation Company.

Carnegie Steel Company Changes

As previously announced in these columns, Colonel Henry P. Bope has resigned his position as vice-president and general manager of sales with the Carnegie Steel Company to devote his time to private interests.



Col. H. P. Bope

Colonel Bope was born and educated at Lancaster, Ohio, and devoted himself at first to stenographic reporting in the Ohio legislature. In November, 1879, he became connected with Carnegie Brothers & Co., and has remained continuously in the sales work of that company and its successors up to the present time. His period of service has thus covered the wide expansion of the use of steel and the

growth of great commercial and business organizations, in all of which he has had a most active part.

He has been succeeded in his office with the Carnegie Steel Company by William G. Clyde. Mr. Clyde was educated in the Pennsylvania Military College, at Chester, Pa. He first entered the employ of Ryan & McDonald, contractors of Baltimore, Md., was then associated with Robert Wetherill & Co., machinists and founders, and was later superintendent of the plate mills of the Wellman Steel & Iron Company, in Thurlow, Pa. His connection with the United States Steel Corporation and its subsidiaries dates



W. G. Clyde

from 1894 when he became superintendent of the plate mills of the Illinois Steel Company at South Chicago. On the formation of the American Steel Hoop Company he became traveling salesman for that company in Chicago, and five months later was made manager of sales at Philadelphia, where he remained until 1902, when, after the formation of the United States Steel Corporation, the American Steel Hoop Company was merged with the Carnegie Steel Company. For the next three years Mr. Clyde was traveling salesman for the Carnegie Steel Company at Cleveland, Ohio. In September, 1905, he was made assistant general manager of sales at Pittsburgh in charge of the bureau of bars and hoops, which office he retained until his present promotion. Mr.

Clyde by the promotion has also become a member of the board of directors of the company.

Charles L. Wood, long assistant to Mr. Clyde, has been promoted to be assistant general manager of sales in charge of the bureau of bars and hoops. Mr. Wood was born in Youngstown, Ohio, in the atmosphere of iron and steel manufacture. He was educated as a mining engineer at the Ohio State University, and his first employment was with the Calumet Furnace Company, of Chicago, as chemist, followed by several years' experience in the practice of mining engineering in Colorado and the West. Mr. Wood became associated with the American Steel Hoop Company on its formation, first in the order department. On the merging of the Hoop Company with the Carnegie Steel Company his abilities caused his transfer to the sales department in charge of the bureau of bars and hoops. His promotion comes as a logical recognition of his large experience in the sale of bar mill products and his wide acquaintance with their users.

H. A. Jackson, sales agent of the Bethlehem Steel Company at Boston Mass., has been elected president of the Chicago Pneumatic Tool Company, with office at Chicago, succeeding W. O. Duntley, resigned. Mr. Jackson was born in Bethlehem, Conn., on July 7, 1881. He is a graduate of the Lawrence Scientific School of Harvard University, class of 1903, but devoted an additional year to a special course in metallurgical work in the graduate school there. Mr. Jackson entered the employ of the Bethlehem Steel Company in July, 1904, where he served an apprenticeship in the various departments of



H. A. Jackson

the works, thus gaining practical experience and an intimate acquaintance with the steel business by personal contact with the production end. He later entered the sales department of the Bethlehem organization. A number of years ago Mr. Jackson was sent to Boston to open the Bethlehem Steel Company's office there and to organize its sales and executive forces in that territory. He continued in the position of sales agent at Boston until his election as president of the Chicago Pneumatic Tool Company at a special meeting of the board of directors held in New York on April 19. He is not an entire stranger in Chicago, where he now has his headquarters, as he was sales agent in that city for the Bethlehem company for several months early in his career.

The Youngstown, Ohio, office of the H. W. Johns-Manville Company is now located at 520 Market street. The same company has also found it necessary, owing to increased business on the Pacific coast, to open new offices at Tacoma, Wash. The office will be located at 1015 A street and will carry a complete stock of Johns-Manville products.

The Abell-Howe Company, 332 South Michigan avenue, Chicago, has been appointed representative of the Standard Malleable Iron Company, Muskegon, Mich., for the sale of malleable castings through its several offices located at Chicago, Pittsburgh, Cleveland and New York. The company has also been appointed representative of the Northern Engineering Works, Detroit, Mich., builders of electric overhead traveling cranes, electric hoists and foundry

equipment, for the sale of these products in the territory tributary to Chicago.

D. B. Clark, who was formerly superintendent of the shell department of the American Brake Shoe & Foundry Company at Erie, Pa., is now general superintendent of the Watervliet arsenal, Watervliet, N. Y. This arsenal is the largest and oldest arsenal in the United States and Mr. Clark has charge of the entire production of this plant.

George W. Bender, assistant to the vice-president of Mudge & Company, Chicago, has been appointed eastern manager, with office at 30 Church street, New York. Mr. Bender was born at Pittsburgh, Pa., on August 20, 1884, and at the age of 17 entered the engineering department of the Pressed Steel Car Company, of that city. In 1906 he accepted a position with the American Locomotive Company, where he had charge of the extra work order department. In 1910 he became associated with Mudge & Co. as chief draftsman, and subsequently was given charge of the mechanical department. Later on he was made assistant to the vice-president, a position he held until his appointment as eastern manager in charge of the business of Mudge & Co. in the New England and Atlantic Coast states.

Charles J. Donahue, formerly assistant vice-president in charge of sales of the American Locomotive Company, died at his home in New York on April 20, after a long illness.

Mr. Donahue was the son of a locomotive engineer. He was born at Cleveland, Ohio, on March 8, 1871. His first position in railway service was in the motive power department of the Lake Shore & Michigan Southern at Cleveland. Here he showed marked ability and was rapidly promoted. He served successively as chief clerk to the superintendent of motive power of the Lake Shore under G. W. Stevens, W. H. Marshall and H. F. Ball, and as chief clerk to W. H. Mordue, general manager. From there he was called to Chicago as chief clerk to C. E. Schaff, vice-president of the Lake Shore. In September 1, 1908, he was appointed secretary to W. H. Marshall, president of the American Locomotive Company, and two years later was appointed assistant vice-president in charge of sales, which position he held up to July, 1917. He retired from the American Locomotive Company to form a company to handle railroad supplies, but ill health prevented the accomplishment of this purpose.



G. W. Bender



C. J. Donahue

CATALOGUES

FLANGE LUBRICATOR.—The economies resulting from a proper distribution of oil to the driving wheel flanges are pointed out in Circular No. D4, called "Flange Lubrication," issued by the Swanson Automatic Flange Lubricator Company, Denver, Colo. Common car or black oil gives the best results with the Swanson lubricator, which is of the automatic type, depending for its action on engine vibration.

HEATING APPLIANCES.—The Macleod Company, 213 East Pearl street, Cincinnati, Ohio, has issued Buckeye Catalogue E, describing several appliances now manufactured by the company, which use crude oil in the heating of locomotive parts. These appliances include a Buckeye flood light, locomotive fire kindler, paint sprayer, locomotive tire heater and several kinds of furnaces. The Buckeye oxy-acetylene welding outfit is also illustrated.

SELF-OPENING DIES.—A booklet entitled "Wells Self-Opening Dies" has been issued recently by the Greenfield Tap & Die Corporation, Greenfield, Mass. It contains a detailed description and illustration of the self-opening die manufactured by that company and shows the tool to be very serviceable and adaptable to widely varying conditions. The different kinds of tripping arrangements, including the pull trip, rim trip, face and lever trip are illustrated.

HEAT INSULATION.—The Magnesia Association of America, with offices at 702 Bulletin building, Philadelphia, Pa., has issued a large, well illustrated portfolio showing the many places in which it is necessary to use heat insulating material in order to save fuel. All statements in this portfolio regarding the value of "85 per cent Magnesia" as a covering for steam pipes and boilers are vouched for by the Mellon Institute of Industrial Research, University of Pittsburgh.

PIPE TOOLS.—Catalogue 38, entitled "Pipe Tools" and issued by the Greenfield Tap & Die Corporation, Greenfield, Mass., shows the complete line of pipe tools made by this corporation. The quick release and quick return features of the Greenfield receding pipe threader are emphasized and the catalogue contains an extensive list of stocks and dies, burring reamers, pipe cutters and wrenches. The back of the catalogue contains considerable useful information and several tables.

MOTOR DRIVEN COMPRESSORS.—The Westinghouse Traction Brake Company, Pittsburgh, Pa., has issued a high grade, finely illustrated booklet describing in detail its complete line of motor driven air compressors, both stationary and portable, ranging in capacity from 11 to 110 cu. ft. Compressed air accessories for doing almost every possible kind of work are included. Users of compressed air tools will find many new features and valuable labor-saving devices in this book, which is designated as publication No. 9035 and has been copyrighted.

CAR INSULATION.—The Union Fibre Company, of Winona, Minn., has issued a booklet entitled, "Insulation of Railway Equipment" which takes up in considerable detail the insulation of refrigerator and other cars. The front of the booklet contains an interesting account of the beginning and evolution of the refrigerator car and a development of the theory of insulation. Further on a description is given of the manufacture of Linofelt which is composed, mostly of flax fibre and is a good insulator. The back of the booklet is devoted to the discussion of a series of actual tests, conducted in 1908 by several railroads, with a view to determining the best practice in refrigerator car construction.

Railway Mechanical Engineer

Volume 92

June, 1918

No. 6

CONTENTS

EDITORIALS:

The Machine Tool Situation.....	299
The Winning of the War Depends on Output.....	299
Changes in the M. C. B. Rules of Interchange.....	299
"Uniformity of Hours"—Demands of Labor.....	300
Another Fuel Shortage Predicted.....	300
Expenditures for Mechanical Improvements.....	300
The Government Orders Standard Locomotives.....	300
Application of the Wage Increases to Shopmen.....	301
The Patriotism of Railway Shop Mechanics.....	301

COMMUNICATIONS:

Industrial Fellowships	302
------------------------------	-----

GENERAL:

A Well Organized Repair Shop.....	303
Wage Increase for Railway Men.....	311
The Railway Industrial Army.....	314
Air Brake Convention Proceedings.....	315
The Poor Little Rich Bill.....	320
2-10-2 Type Locomotives for the U. P.....	321
A System of Labor Compensation.....	325
Limitations to the Capacity of Coal Cars.....	329
Drafting Modern Locomotives.....	331
Conserve and Reclaim Material.....	333
A Decade of Progress in Building Steel Passenger Cars.....	334
The Railway Tool Room.....	335

Expedite Locomotive Repairs.....	341
Local Stresses in Box Bolsters.....	343
Repairing Foreign Locomotives.....	348
Large Appropriations for Shops.....	349
The Fuel Association Convention.....	351
Car Wheel Drop Pit.....	356

NEW DEVICES:

Motor Driven Geared Head Lathe.....	357
Bullard 61-in. Maxi-Mill.....	358
Arch Bar Drilling Machine.....	359
A Heavy 42-in. Planer.....	360
Ready Boring Tool Holder.....	362
American 36-in. High Duty Lathe.....	362
Universal Flat Turret Lathe.....	363
Peerless Reamers.....	364
Hydraulic Bending Press.....	365
Combination Axle and Journal Truing Lathe.....	365
Foster Universal Turret Lathe.....	366

GENERAL NEWS:

Notes	368
Meetings and Conventions.....	370
Personal Mention.....	371
New Shops.....	373
Supply Trade Notes.....	373
Catalogues	376

The Machine Tool Situation

With the railroads in the market for approximately \$15,000,000 worth of machine tools and with the Ordnance Department requiring a number of special tools valued at the same amount, to say nothing of the requirements of other war industries, the tool manufacturers of this country are face to face with a problem which must be solved and which will necessitate an increase in the capacity of their plants. Undoubtedly the requirements of the Ordnance Department will be considered first, but that does not mean that the requirements of the railways can safely be neglected. The shop and enginehouse equipment of the railroads has for years been notoriously deficient. These conditions were largely responsible for the condition of the motive power last winter, and every attempt should be made to put the power in good shape for the coming winter. Without cars and locomotives, and enough of them fit for active service, the production of the country will be seriously curtailed, with a corresponding effect on the part this nation will play in the war. Upon the response of the machine tool builders to the demand for machine tools depends to a very large extent the effectiveness of our railroads and all our war industries.

The Winning of the War Depends on Output

"The money cost of anything," says Arthur T. Hadley, president of Yale University, "is the amount of dollars and cents which we pay for it. The real cost is the amount of labor and sacrifice which we undergo in order to win it. This war is not fought with dollars and cents—it is fought with labor and with the products of

labor, with men and ammunition, with railroads and ships, with coal, and iron and wheat." This statement brings home clearly a fundamental principle of economics. Money is a mere medium of exchange. Work, the amount of it and the economy with which it is used, determines the wealth of a warring nation. We all put ourselves on the back when we learn of the large number that subscribed to the Liberty Loans; but money is no measure of patriotism, particularly when it is invested in a gilt edge security. It is the self-sacrifice, hard work and the increasing of one's efficiency that count and will do most towards winning the war. Upon the workman in the United States rests a tremendous responsibility. It is upon his output that the success of the Allies depends. It is no longer a question of how much he earns, but *how much work he produces.*

Changes in the M. C. B. Rules of Interchange

By far the greatest problem to be considered at the meeting of the Master Car Builders' Association in Chicago this month, is the revision of the M. C. B. Rules of Interchange. The unification of the railroads in this country under the Railroad Administration has made it possible to inaugurate more economical methods of interchanging cars and of making repairs. Already various local agreements have sprung up in different sections of the country, which expedite the matter of repairs in interchange. This has been done with the cognizance of some of the regional directors and at the present time no absolutely unified code of rules is being practiced.

The M. C. B. Association has a splendid opportunity of revising the method of handling repairs and interchange to

suit the new conditions. Strictly speaking there is no foreign car. The quicker the mechanical department officers and their forces recognize this, the sooner will the beneficial effect of unification be felt. From this broad view of the situation there is much to be done to the M. C. B. Rules. If it is not done by the Association there is no question but what others in authority will insist upon a revision, or revise the rules to suit themselves.

"Uniformity of Hours"—Demands of Labor

Federated Trades have forced the Rock Island Lines, through the Railroad Administration, to work all the shops in either the car or locomotive departments the same number of hours that any other one shop is worked. That is, if because of the locomotive situation at one point it is found necessary to work a shop 10 hours a day, every other locomotive shop on the system, will work ten hours a day, regardless of the amount of work to be done! Does this represent a true American spirit? What logical reason is there for holding under pay thousands of employees doing nothing while possibly a few hundred are working hard to catch up?

Early in March the Rock Island Federated Trades endeavored to put this ruling into effect on the Rock Island. They succeeded in doing so a month later. They are now asking pay for the men who would have spent their time idle in the shops had their requests been granted at the first appeal. This point, we understand, has not yet been settled. Can the nation afford to pay the wages of idle men while their comrades work? Is it truly American to "hold up" the government in this way? Will this not lead to disastrous results as the roads become thoroughly unified? Permitting the number of hours of work to be regulated by the most crowded shop means a great waste of money.

Another Fuel Shortage Predicted

The men attending the recent convention of the International Railway Fuel Association at Chicago were given a new idea of the seriousness of the problem of supplying coal for all the nation's needs during this year. It is one of the big tasks of vital importance to the successful prosecution of the war and one in which railroad men must play a large part. The Fuel Administration states that 650,000,000 tons of bituminous coal will be needed this year. As compared with the normal consumption of three years ago this represents an increase of 200,000,000 tons. This increase in the coal traffic, which must be carried by the railroads, is enough to fill 16 tracks of gondola cars reaching from New York to San Francisco.

To meet the requirements for this year, there must be mined and transported every week 12,500,000 tons of bituminous coal. Up to the present time the *maximum* production for any single week has never been more than 95 per cent of the required *average* production. The prospect for any great increase in the output of the mines is slight. Unless the difference between the country's requirements and the actual production can be saved, it will be necessary again to shut down industries, with the resultant loss and suffering.

The United States Fuel Administration, the Railroad Administration and the fuel administration of the various states are doing their best to meet the impending crisis. Everyone can help the cause, none more effectively than the railroad man. One of the important factors restricting the output of the mines is the shortage of cars. Anything that is done to increase the car supply, either by keeping cars off the repair track or by providing power to move them faster, will make it possible for the mines to furnish more coal.

The railroads use over one-fourth of all the coal mined in this country. Conservation of fuel by the railroads is therefore of the utmost importance. Practically every employee can help in this work of conservation. It has been said that if every man who burns coal will do the best he knows how without a word of new information, the saving will result in plenty of coal for every purpose. The winning of the war may depend upon securing an adequate supply of fuel. Railroad men should work with this thought in mind, and they should carry the message to all with whom they come in contact. They should not only do their part, but so far as they are able, they should see that the other fellow does his share as well.

Expenditures for Mechanical Improvements

The consideration which the request for expenditures to improve mechanical facilities received at the hands of the Division of Capital Expenditures of the Railroad Administration must be a source of great satisfaction to the mechanical department officers. For years these men have included in their annual budgets requests for just such work, only to have them either denied or materially cut. The roads were not allowed to earn enough money to warrant such expenditures. No physical equipment of the railroads has been so sadly neglected as the facilities for repairing cars and locomotives. The Railroad Administration is clearly alive to this situation and is to be congratulated on its clear vision in this respect. The severe weather last winter accentuated the serious effect more than any other thing could have done. The lack of proper facilities for handling repairs to the equipment greatly increased the operating costs and did much to cut down the effectiveness of the roads. With approximately \$75,000,000 for shop buildings, enginehouses, etc., and approximately \$15,000,000 for shop machinery and tools, the roads, if the work can be done promptly and the necessary material and tools provided, will be in far better shape to provide the necessary equipment for the constantly increasing demands of traffic than ever before in their history.

The Government Orders Standard Locomotives

On April 30 the Railroad Administration placed orders for 1,025 standard locomotives of the twelve different designs which were briefly described in our last month's issue, distributed as follows: 400 light Mikados, 100 heavy Mikados, 35 light Mountain types, 5 heavy Mountain types, 30 light Pacifics, 20 heavy Pacifics, 150 light 2-10-2 types, 35 heavy 2-10-2 types, 50 six-wheel switchers, 150 eight-wheel switchers, 30 (2-6-6-2) Mallets and 20 (2-8-8-2) Mallets. The orders were distributed between two locomotive builders—555 to the American Locomotive Company and 470 to the Baldwin Locomotive Works. Each builder was given some of each of the twelve types to build in order that they may be equipped with the necessary dies and patterns for all of the standard designs. This was done regardless of the fact that by so doing the time of the deliveries of the locomotives would be prolonged.

These locomotives, representing a composite design to operate on the average railroad, will be distributed—as soon as they are built—to those, who in response to the circular issued early in April by Henry Walters of the Railroad Administration, indicated the number of locomotives necessary to meet their requirements for this year. Whether or not these roads will be compelled to pay for these locomotives, or whether they will remain strictly government equipment, has not yet been determined. When the orders were placed, deliveries were promised in July. As this is written, the early part of June, the drawings have not been completed. It begins to look as though there would be no very large number of these locomotives delivered much before September.

The question of specialties to be used on the locomotives is still in the controversial stage. From what little information has been given out regarding these, it is understood that all the locomotives are to be equipped with non-lifting injectors and over half of them will have stokers. All will be equipped with superheaters, brick arches, incandescent headlights, automatic firedoors and other labor saving devices.

Those roads that are planning on using these standard locomotives should at the first opportunity study the details of design in order that the repair points may be properly equipped to handle the repairs to them. If this is not done there is a possibility of the locomotives being held out of service unnecessarily when failures occur. The detail standards adopted on these locomotives will to a very large extent be different from existing standards on most roads. This, therefore, makes necessary a careful examination of the new designs in order that the roads may protect themselves.

Application of the Wage Increases to Shopmen

It was unfortunate that the report of the Railroad Wage Commission was made public before the director general had an opportunity to approve or disapprove it. Based on purely theoretical lines, it did not give the railway shopmen the consideration they deserved. In fact, the "increases" were such that had there been no saving clause, many of the shopmen would have owed their companies for over pay. While the method of computing the increases on a sliding scale basis shows a commendable desire to give to those who need most, it did not take into account the practical consideration of the laws of supply and demand. The demand for mechanics and shop labor has increased at a rapid rate ever since the nation entered the war. As time goes on and facilities for manufacturing munitions, ordnance and other war materials increase, demands for this class of labor will be still further increased.

In order to hold the men at all during the past eighteen months, the railroads have been forced to grant considerable increases. It is for that reason that the commission's report, based on the wages in 1915, showed no increase for shopmen. The director general appreciating these conditions has established a minimum wage of 55 cents an hour, which is an increase of approximately 10 per cent more than the men are receiving now and what the commission granted. Regrettable demonstrations have been made against this award in spite of the fact that when he issued it, the director general appointed a Board of Railroad Wages and Working Conditions, which included representatives of the labor organizations. It is to be the duty of this board to pass on all petitions and complaints raised in connection with the award.

Shortly after the award was announced, the representatives of labor raised strong objections to the award and requested a minimum wage of 75 cents an hour. The unreasonableness of this demand is appreciated when it is known that the minimum wage in the shipbuilding industry for machinists is less than 65 cents, for boilermakers and pipefitters about 70 cents, and for blacksmiths about 72 cents. At the plant of one of the locomotive builders the minimum wages for the different crafts are as follows: machinists, 50 cents; boilermakers, 45 cents; blacksmiths, 50 cents, and pipefitters, 50 cents. The maximum rates at this same place are 65, 72, 65 and 65, respectively. The work done at the locomotive building plant is far more comparable with the railway shopman's work than the work done in the shipyard.

Furthermore, the conditions surrounding the work of the craft-man in the shipbuilding industry are far less congenial than the work of the railroad mechanic. A worker in the shipyard takes a gamble on the permanency of his position. He is working under constant pressure; it is difficult for him to find a suitable and congenial place in which to live and

bring up his family, and his living expenses are greater than those of the men in railway towns, many of whom own their homes. He is entitled to high wages to make up for these disadvantages. Any demand for an equal rate by the railway shopmen is, therefore, unquestionably unreasonable. There are men at the present time in railway shops, particularly those working piece work, who even under the old regime were making especially large wages. The demand for output has so greatly increased that the pay of these men has been restricted only by the quantity of work they were physically able to do. Frequently we hear of cases where second rate mechanics working as specialists on a single machine, make much more than the foremen and even more than the head of the shop. A 75-cent rate would make these men plutocrats and greatly destabilize labor conditions.

If any one group of men in a railway shop has a right to complain, it is the foremen. It is impossible to expect these men to remain contented and satisfied with their positions when the men under them and for whose work they are responsible, are receiving more than they. In fact, some of the foremen have returned to the ranks because of the greater remuneration. Unless these men are properly taken care of either through the newly constructed wage board, or through the general offices of the railroad, efficient supervision cannot be expected, nor that esprit de corps which is so essential in a railway shop.

The Patriotism of Railway Shop Mechanics

"It is the first time in the history of our government that any of its employees have attempted to strike against their government." Director General McAdoo in saying these words sets in bold relief the few men at Alexandria, Va., and at Silvis, Ill., who "deserted" the ranks of the railway shop forces at these points. These men were not satisfied with the minimum wage of 55 cents an hour, even though the director general in announcing this minimum wage made provision for consideration of any objections through a board containing accredited representatives of the railway shop craft organizations. What has become of the patriotism of the American workingman that he should so far forget himself as to respond to the call of STRIKE from—shall we say—a German propagandist? Have these men the interest of the nation at heart? Do they realize that upon their work depends the successful prosecution of the war? Have they forgotten that hundreds of thousands of our American boys in France depend upon them to do their part in delivering supplies and ammunition, that the lives of our soldiers need not be sacrificed?

It is reported that John McManamy, supervisor of equipment of the Railroad Administration, influenced the men of the Rock Island at Silvis, to return to their work as a matter of loyalty to the nation. It is inconceivable to believe that these men went on strike in cold blood and with a full realization of what their action meant to the country and what extreme satisfaction and encouragement it gave the enemy. Strange as it may seem, every one of the two thousand striking men at Silvis subscribed to the Third Liberty loan. The Rock Island was the only road in the west having a full 100 per cent subscription. It shows there is something lacking in our method of teaching the men what their duty to the nation is, and making them understand what an important part they play in helping this nation win the war. There is need for much to be done in this respect. Every shop officer, from the superintendent down to the gang foreman, must talk patriotism to the men. We have had Liberty Loan drives and Red Cross drives—let us now have a *Labor Drive*. Hold noon meetings, talk with the men at their work, in their homes, on the street, anywhere you get a chance. Tell them *why* we must have cars and locomotives and show them the real part they play in the war.

COMMUNICATIONS

INDUSTRIAL FELLOWSHIPS

LAFAYETTE, IND.

TO THE EDITOR:

Since the publication of my article dealing with the relations between the railroad and the university, which appeared on page 18, of the January, 1918 issue, I have received a number of letters making inquiries as to the nature and conduct of such joint arrangements.

The term "fellowship" has been generally used to denote a plan whereby a college graduate may continue his education, devoting a part of his time to this and a part to work for the benefit of the university. A fellowship is distinguished from a scholarship in that the latter is usually a method of enabling an undergraduate to continue his studies by giving him some form of financial assistance, while a fellowship extends aid to postgraduate workers. The advantage of the fellowship to the individual is that it takes care of his necessary expenses while working for his master's degree. The advantage to the university is that of having the services of a trained assistant at a comparatively small expense. Fellowships have generally been endowed by the university or by friends of the institution with the idea of encouraging graduate work in various branches.

The industrial fellowship represents comparatively a new development. I think the first fellowships of this character were instituted at the University of Kansas in 1907, Robert Kennedy Duncan being responsible for the innovation. In 1911, Dr. Duncan was called to the University of Pittsburgh to inaugurate a similar system there. In 1913, the Mellon Brothers endowed the Mellon Institute for the express purpose of furthering industrial research and from 1911 to the present time there has been a constant succession of investigations at this institution. Investigations made at Kansas and afterwards at Pittsburgh have been largely of a chemical character having to do with the study of various commercial products including metallurgical, medicinal, clothing, food and fuel products. The fellows, working under this system, receive varying amounts from \$1,000 a year upwards according to their experience and the importance of their work. They devote all of their time excepting three hours per week to the research work. The funds are supplied by various firms interested and the results of the work become the property of those contributing. The fellow frequently receives a commission or bonus in addition to his salary, dependent on the profits ensuing to the contributors. All the resulting patents must be assigned to the company and the report or monograph becomes its exclusive property for three years. At the end of that time the results may be published by the university unless there is objection. Any questions at issue between the two parties to the arrangement may be settled by a board of three arbitrators appointed in the usual way. This is the most conspicuous example of industrial research in this country and it seems to be eminently satisfactory both to the university and to the contributing interests. The fellows are university graduates from various institutions in this country and abroad. Since 1911, the number of fellowships has increased from 11 to 42, the number of workers from 24 to 65 and the amount contributed from \$40,000 to \$150,000. The Mellon Institute thus far has given less attention to engineering than to chemical subjects.

At the University of Illinois, in connection with the Engineering Experiment Station, industrial fellowships have been established by the Illinois Gas Association. The fellows are selected from engineering graduates connected in some way with the companies forming the association. Each man

works for two years, devoting half his time to research and receiving \$500 per year for his services. This enables him at the same time to get his master's degree. The work is naturally of a chemical engineering character. The results, however, are published by the university and become public property, the object of the investigation being not to benefit the separate corporations but the gas business as a whole.

Many of the large industrial corporations, including two or three of the railroad companies, maintain research laboratories of their own where their own particular problems can be solved without any assistance from outside. There are, however, many smaller corporations who do not find it expedient to maintain well equipped laboratories of this sort and who are in the habit of taking various problems to the laboratories of the technical schools for solution. Speaking for the institution which I represent, I may say that Purdue has always carried on work of this kind for the railroads and for various manufacturing corporations. The companies have paid liberally for this service and in the main seem to have been satisfied with the results obtained. These researches are, however, more or less sporadic and their success depends largely on the conditions obtaining at the time when the work is done. It is quite evident that the industrial fellowship would offer a more promising plan. The corporations on their part would have the advantages of regular service in a well equipped laboratory with a staff of trained investigators. The university on its side would have the advantage of contact with the practical problems of the day in a very concrete way. The fellow who is the recipient of the income from the fellowship has an opportunity of pursuing advanced study for his master's or doctor's degree and at the same time of working on a definite industrial problem of commercial value and possibly of working into a permanent position of responsibility. The research engineer of the manufacturing company is usually too much pressed with immediate problems to give proper time and thought to true scientific investigation. The fellow in the university can concentrate his efforts on the one problem at his disposal. This plan may be further expanded by giving the fellow an opportunity to work in the shops and laboratories of the corporation, making his experiments on actual machinery or production in the process of manufacture.

There are a number of important scientific and engineering problems confronting the railroads today. Only a few of the roads can conduct satisfactory research on these problems. By the expenditures of from \$500 to \$1,000 annually, a railroad might carry on an investigation with good laboratory facilities and well trained assistants. A group of railroads could do much more, while the large railway associations could carry out a plan of this kind with benefit to all the roads in the association since the results would be published in the proceedings and be for the general distribution. The only approach to this thus far is the Ryerson Scholarship which is administered by the Master Car Builders' Association and which takes care of a certain number of students in railway engineering during their college courses. There is no attempt in this to accomplish any work for the railroads but merely to assist in educating railroad engineers. The industrial fellowship promises equal benefits to the individual student and at the same time well repays the railroad.

In view of the many important engineering problems confronting the railroads and the numerous technical universities having laboratories at their disposal, it would seem to be another step forward in conservation and efficiency to combine the two along the lines which have been indicated. It is for the railroads to take the first step, and they may be assured that many if not all of the universities will gladly co-operate.

C. H. BENJAMIN,

Dean, Schools of Engineering, Purdue University.

A WELL ORGANIZED REPAIR SHOP

A Study of Methods Followed in Repairing Locomotives on the New York Central at West Albany



THE West Albany (N. Y.) shop of the New York Central is located at a particularly strategic point for the section of the road it serves, handling the backshop repairs for practically all of the 1,200 New York Central locomotives operating east of Syracuse, N. Y. There are 22 roundhouses in that section, which call on West Albany for all of the machine work they are not equipped to handle. This shop has 40 working pits in the two erecting shops which extend out from each end and at right angles to the

for the corresponding months in 1912 and 1917. While 57 of the 128 locomotives repaired during the month of January, 1918, were given light repairs, due largely to the severe weather last winter, it will also be noted that the amount of heavy boiler and machine repairs has been materially increased since 1912. It may also be said that some locomotives receiving practically general repairs were credited with class *F* repairs only because the tires were not turned. This is due to an old established rule and happens whenever a locomotive with light mileage and good tires is badly wrecked.

This increase in output was obtained with a decreasing working force. The average number of men employed during the first four months of 1912 was 1,331, or 205 greater than during the corresponding months in 1918. In addition to this, West Albany has been called upon to repair locomotives for other roads, which has not made maximum output

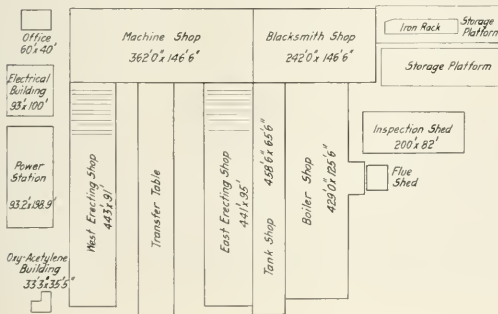

Fig. 1.—General Arrangement of the West Albany Shops of the New York Central

machine shop with a transfer table between them, as indicated in Fig. 1. The shop is not particularly well equipped with machine tools, but with a loyal and enthusiastic organization from the shop superintendent down to sweepers, a very creditable output of repaired locomotives is obtained. Most of the 1,133 men employed operate under the piece work system, working 60 hours a week and they specialize in their work to a high degree. It is the purpose of this article to describe the organization of this shop, calling attention to the methods and practices which make for increased output.

SHOP OUTPUT

During the first four months of the present year 458 locomotives, or an average of 114 locomotives per month, were repaired at the West Albany shops with an average force of 1,126 men. This represents a material increase over past years, as indicated in the table of shop output showing the number of locomotives repaired under the different classes

CLASSIFICATION OF REPAIRS AND OUTPUT AT WEST ALBANY								
	A	B	C	D	E	EF	F	Total
1912								
January	0	1	3	11	12	3	7	37
February	0	1	11	17	17	1	10	57
March	0	1	0	9	29	14	7	63
April	0	1	4	36	20	3	10	74
1917								
January	0	5	2	17	29	9	16	78
February	0	7	3	8	26	10	6	60
March	0	5	4	26	23	10	14	82
April	0	3	0	28	26	5	13	75
1918								
January	1	3	2	8	39	18	57	128
February	1	3	2	2	44	22	46	120
March	1	6	1	11	43	18	30	110
April	1	5	2	14	47	16	15	100

Class A—New boiler and general repairs to machinery.
 Class B—New firebox and general repairs to machinery.
 Class C—New side sheets and general repairs to machinery.
 Class D—New tubes, tires turned and general repairs.
 Class E—Tires turned, general repairs to machinery.
 Class EF—Failure of any important part of machinery not due to accident.
 Class F—Light repairs to machinery.

possible. Being unfamiliar with the standards required by other roads, the shop would find it difficult to do the work with as great despatch as was possible on New York Central locomotives. In some cases it was necessary to await instructions and repair parts for these locomotives.

The only material improvement in the shops since 1912 which would affect the output was the addition of an outside inspection shed, an addition to the tank shop and the piping of the shop for acetylene gas, which is used almost exclusively for cutting operations. The location of the inspection shed is shown in Fig. 1. The tank shop addition is between the east erecting shop and the boiler shop and

was at one time an open storage platform served by a 20-ton crane.

ORGANIZATION

There are evidently some one or more reasons for the results accomplished at West Albany not accounted for by the shop facilities or the number of men employed and it is not necessary to be at the shop long in order to discover the most important one. It is in the personnel of the management, from the superintendent down to the youngest foreman. Almost without exception each one has risen from the ranks, being a practical man and an expert in his particular line. All the foremen co-operate in the closest possible way and taken together they form an enthusiastic unit in turning out locomotives. They possess the confidence and respect of the workmen to an unusual degree and even the truckers have caught the spirit and appear anxious to keep things moving.

A chart of the organization is shown in Fig. 2, together with the number of men working in each department. Of a total number of 1,133 men employed in March, 1918, some clerks, office men and others not shown under any of the subheads in the diagram are included.

PIECE WORK SYSTEM

Another reason for the improvement in production is undoubtedly the system of payment by piece work that has been developed at West Albany. This system gives the work-

traveling inspector and the supervisor of piece work at New York, and is finally placed on the piece work schedule for that class of work. Once in this schedule, the price is never cut, unless some new device or jig or quicker way of doing the work is developed. But what is done if the men speed up and make too much money? In that case if the quality of the work is up to standard nothing is said. The piece work price as finally set is reasonable and with it the average machinist can make a good day's pay. If he is above the average he gets the extra money; the company gets the work. The policy of not cutting prices has been followed consistently, so that the men have every confidence in the management and it would be hard to find a better satisfied, or more loyal group of men in any railway shop.

TRAINING MEN FOR SPECIAL WORK

Another important practice followed in this shop is the changing of men about until each one finally obtains work to which he is adapted. Many of the men who are doing the best work are not all-around mechanics, but have been developed for the particular job which they are doing. If a foreman knows of a man who he thinks is adapted for a special job, the man is given a chance to show his worth. With no preconceived notions he can make the most of the foreman's instructions and often develops into a valuable man. Very often it happens that one man does all of a cer-

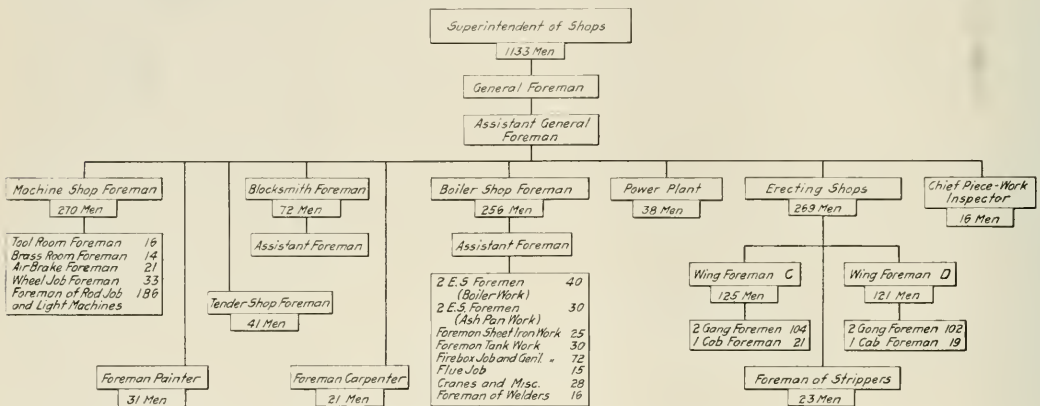

Fig. 2—Diagram Showing the Organization at West Albany

men every incentive to speed up, exercise their industry, concentration and ingenuity, and produce results. It works out in practice as follows: In setting the price on a new piece of work, the piece work inspector times the man doing the work and bases a trial price at 25 per cent over his day rate. This price will probably be too high, but as the man becomes more familiar with the work, the price can be lowered and still allow him to make 25 per cent over his day rate. When the inspector gets the trial price to a point which he thinks is fair to the man and the company, it is turned in to the chief inspector, with a detailed description of the work. By comparing it with the prices for the same kind of work at different points on the system, the chief inspector may find that this trial price is still too high, in which case he turns it back to the shop inspector with his decision. The shop inspector then decreases the trial price again, showing the man, if possible, how the work may be done more quickly. The new trial price is then returned to the chief inspector and again compared with the prices at other points. When finally acceptable to the chief shop inspector, the trial price is submitted for approval to the

tain class of work for the entire shop, but an understudy is usually trained so that no one man becomes indispensable. A special point is made of not blaming a man for the first mistake, as it is figured that the man is always worth more than the job, and according to the old truism, "He who never makes a mistake never does anything."

Every effort is made to diminish the trucking about the shop as much as possible by localizing the work. One machinist and an apprentice do practically all of the laying out for the machine shop and go from one place to another, laying out work at the machine on which it is to be done. For example, new main rods are taken from the milling machine to the radial drill, which is nearby and the bolt holes are laid out, thus eliminating movement of the rod to and from a laying out table. Another good example is in the method of machining and laying out cylinders. The cylinder boring machine is located next to the planer and while the boring bar is going through the cylinder the machinist lays out the valve chamber and stud holes. Relief valves and by-pass valves are also laid out so that by the time the boring operations are completed the cylinder is ready for the

drill. The machinist gets an extra rate for this work and the company gets the cylinder so much quicker.

ECONOMY DUE TO ELECTRIC WELDING

The electric welding process as developed at West Albany has resulted in marked economies and it is used extensively on boiler work and for the repair of all kinds of cast iron and steel machine parts. Almost no part is so badly damaged that it cannot be repaired by this method, the only limit being when the value of a new part is less than the cost of welding the old. All broken frames are repaired by electric welding and it is estimated that less than five per cent of these break a second time. All kinds of cylinder welds are made and the success in this field has been largely due to the proper arrangement of holding studs. Welding practice on boiler work is not essentially different from that at other shops, but on the whole West Albany has had better than the average success in welding, particularly in welding cast

each man. Many welders hold too long an arc and use too much current, with the idea of doing a quick job, but the experience at West Albany has shown that a close arc gives better results as a rule, and that the best current to use is from 120 to 140 amperes with 12 to 20 volts.

SHOP SCHEDULE

The schedule system as originally installed at West Albany has been discontinued, although certain features are still maintained, such as the weekly calendar showing the date locomotives are due out. It was felt that foremen could keep in closer touch with the work by following it personally than to get their information from a schedule clerk, and the present system is believed to be more flexible in case it is necessary to replace one locomotive by another. Each Thursday night the boiler shop foreman gives the general foreman a list of the boilers that are to be tested the following week. Friday morning the general foreman with the erect-

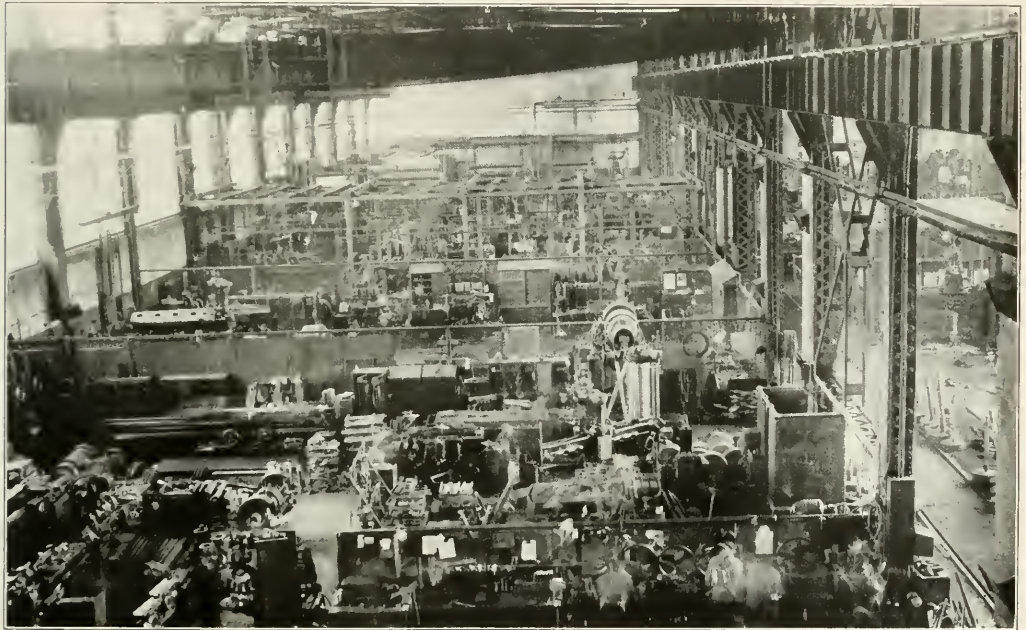

Fig. 3—General View of North Side of Machine Shop

iron. Broken cast steel wheel centers, coupler bases, trailer spring yokes, etc., are all repaired by electric welding.

There are other examples of what may be done by the welding process, and the resourcefulness of the foreman. One locomotive recently had a wrecked left guide yoke and there was none in stock. A right hand yoke was machined, the ribs and guide knees cut off with the acetylene torch and electric welded back on again on the reverse side, thus making a left hand yoke. The great saving in cost of material and labor effected by welding is largely responsible for the fact that in the past six years the cost of locomotive repairs has not increased over one-quarter of a cent a mile.

The electric welding equipment consists of one alternating current and six direct current machines. The work is done by 16 experienced men who are under the direction of a foreman welder. The success in welding wrought iron and steel is said to depend not so much upon the machine as upon the operator and especial attention is given to training

shop foremen personally inspect each locomotive and together they decide on the day it will probably go out. This date is put on the weekly calendar, later to be distributed throughout the shop, and each man then knows not only the order in which to work on the locomotives, but by experience, how long before the "due out" date his particular work must be done. In case a broken cylinder is discovered or other unexpected job, it is easy to substitute another locomotive and thus keep the weekly output fairly constant. In addition to the Friday inspection, the general foreman makes an inspection of the locomotives each morning and in this way keeps in the closest possible touch with the situation. There is a staff meeting of all foremen Monday, at which matters of general interest regarding the work are discussed.

MACHINE SHOP

The department that limits the output at West Albany is the machine shop and it has been found necessary to work

a small number of machinists nights on those jobs that are behind. The wheel job is somewhat delayed by the need of more crane service and a large tire boring mill which was promised for last spring, but which was requisitioned for government service. It is planned in the near future to install an additional turret lathe for the special purpose of making link pins and bushings. The fit of the pins in the bushings will be made standard and by making these pins in quantities on the turret lathe, a large saving is anticipated.

A general view of the north part of the machine shop is given in Fig. 3. The link and piston jobs are in the foreground. The central enclosed section is the tool room. Fig. 4 shows the south section of the machine shop. This is devoted almost entirely to driving wheel work. The foreman's office is shown near the center of the shop with a 100 per cent Liberty loan flag over the door.

The machine shop output has been increased by many slight changes in machines and one of these is shown in

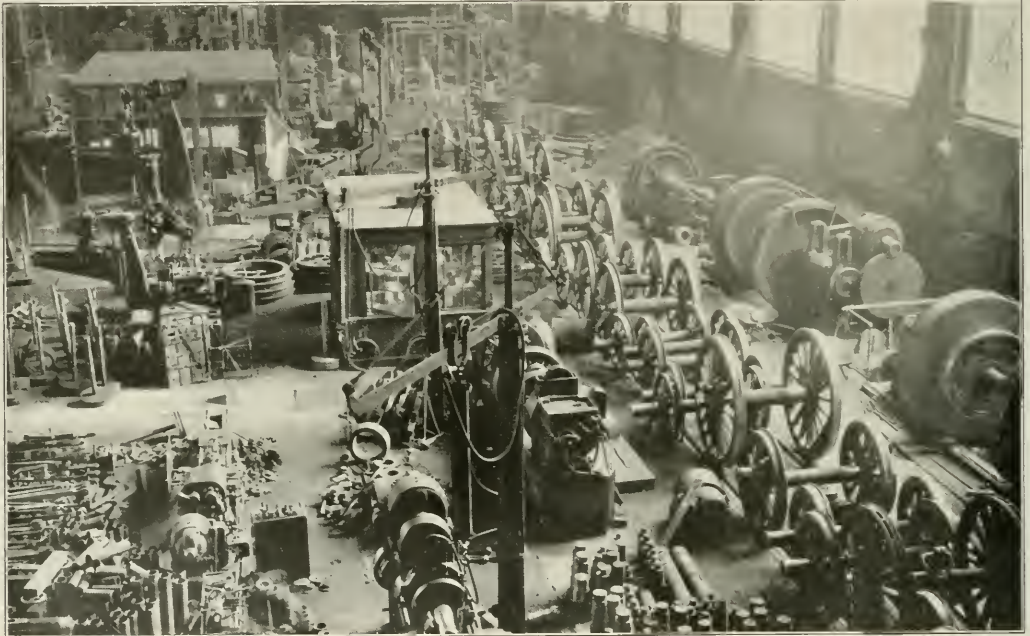

Fig. 4—General View of South Side of Machine Shop

Fig. 5. A journal lathe was changed by putting 7-in. filling blocks under the head and tailstocks and the tool post, thus making possible the turning of cut trailer journals without removing the wheels.

The simple expedient of clamping a bench vise to the table of a drill used for miscellaneous work reduced the cost of drilling almost a third. This arrangement is shown in Fig. 6 and the casting being drilled is a pipe manifold. Fig. 7 shows the way in which wrist pin washers are machined on an arbor twenty at a time. These washers are later bored in lots of six by the same machinist and he is able to make from 60 to 70 a day. It may be said in passing that the workman on this machine is one of the greatest producers in the shop. Knowing that the piece work prices are fixed, he works hard and it is not uncommon for him to receive as much as \$250 per month. He is an exceptionally rapid and efficient workman.

THE ROD JOB

With a required output of three to four sets of heavy rods per day, it means that men on the rod job must make the most of every minute. The work is under the direct supervision of one of the assistant foremen who has several able machinists on the work. Fig. 8 shows the horizontal milling machine on which new rods are milled, and particular attention is called to the arrangement used for holding the rod. It is held on centers and supported as shown by four screw blocks and a central jig with taper attachment to raise or lower the parallels. When it is desired to mill the opposite side of the rod, the wedges and blocks are loosened and the rod turned on the centers and made parallel with the bed by the screw blocks. By this means the total time of setting up the work is much reduced. The man who does this work has been on the job for seven years and understands it so thoroughly that while the machine is worked to its utmost capacity, it is able to do all of the rod milling work.

A vertical miller which machines the end of the rods is

also worked to capacity and by a man who understands how to get the most out of the machine. The general rule at West Albany is to work the tools to the most economical feed and speed and to work the machines until, judging by the sound, they are carrying all that is safe. One boring mill only is used in making the rod bushings and boring the brasses, and here again, a man of especial ability is used on the job. He is not an all around machinist, in fact having been taken from the boiler shop, but he has learned that particular machine and would be a hard man to replace.

Driving Boxes and Wheels.—Needless to say, one of the important parts of the work is the repairing of driving boxes and wheels. It is possible to heat three sets of driving wheel tires in the large tire heating furnace at the same time and this is a material help in increasing the output. Another thing that helps the floor men is the setting of all crank arms and making the keys before the wheels are sent

to the floor. A special gage is used, which insures accuracy, and with the crank arms set correctly, the valve setter's work is much easier. The practice in handling box work is particularly interesting and should receive especial notice. The crown brass fit in the driving box is made on a slotting machine which machines all brasses under 19 in. in length.

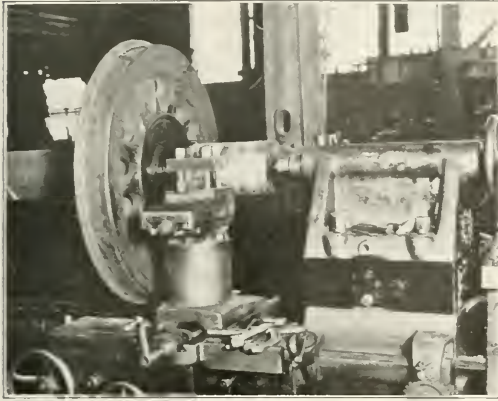

Fig. 5—Journal Lathe Arranged to Turn Trailer Journals Without Removing the Wheels

One man operates this machine, fitting about twenty-four brasses a day besides pressing the old ones out and the new ones in. He makes on an average eight dollars a day and is able to turn out the work on account of long experience and natural aptitude.

The Gisholt boring mill, shown in Fig. 9, is used for

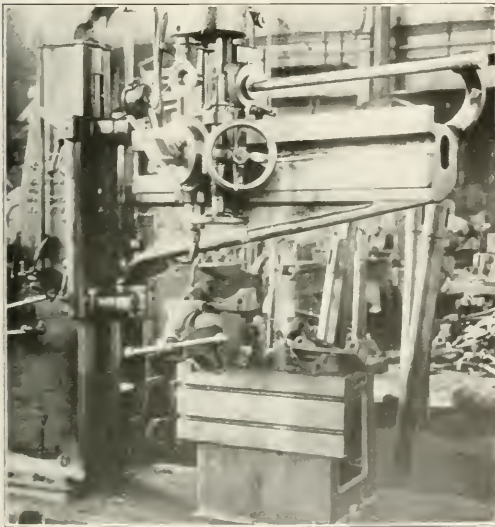

Fig. 6—Bench Vice Used in Connection With a Radial Drill

boring boxes and is also worthy of note, because it is especially designed for this work and handles from 24 to 28 driving boxes a day. A special patented chuck, shown in Fig. 10, made by the Gisholt Machine Company is used with the mill and it eliminates much of the time previously

spent in laying out boxes. The box is centered automatically and bored by means of a special boring bar. After the box has been bored, it is possible to adjust the chuck off center so that the grease clearances may be cut without reclamping the box.

The operator of this machine is an all-around mechanic, who has been in the service of the company for 23 years and averages \$175 a month on this work. He offers an excellent example of the way in which West Albany workmen look ahead to their work, co-operate with their foremen and are interested in seeing the locomotives go out. He takes special pride in the condition of his machine. He provides himself with any necessary repair parts and usually makes the repairs to the machine. Such interest as this would be hard to find in a shop where men are not proud of their work and anxious for big production.

The boring mill which recesses the driving boxes for brass side bearings is an old machine and is one of those which it is necessary to work at night in order to keep up with the work. Under the present arrangement, two machinists are able to fit all of the boxes to the journals and put up the cellars, making the wheels ready to go under the loco-

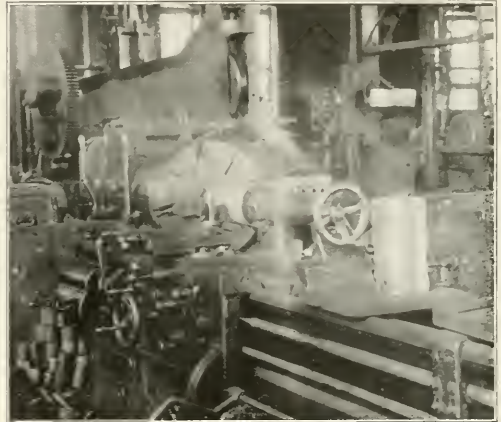

Fig. 7—Turning Twenty Wrist Pin Washers at One Time

motive. This work is done under a runway equipped with two pneumatic hoists.

Two brass furnaces of the cylindrical type are used and all cross-head shoes are brassed in addition to the driving boxes. The making of brass castings for other parts of the shop is discouraged, but in case of an emergency any brass machine part not carried in stock may be cast. Some way is always found out of the difficulties that arise on the box job and the foreman with his initiative, enthusiasm and good judgment usually points the way.

Grinding Work.—There are two grinding machines at West Albany, one an old machine used in grinding truck journals, and the other a comparatively new Norton gap grinding machine used for grinding piston rods, shafting, crank pins, valve stems, axles (after being rough turned), and piston heads when they are nearly to the limiting size. Another job which is done very advantageously on this grinder is the finishing of piston valve packing rings. Ten rings are machined, cut, compressed and placed in a special holding jig between the centers of the grinder, as shown in Fig. 11. They are then ground and when placed in a newly bored valve chamber will expand to fit the bushings, making practically a perfect job. In connection with the grinding of journals, it may be stated that these journals

are rolled after grinding, the idea being to obtain a harder bearing surface more like that of a second hand journal.

Piston Job.—The method of applying piston heads to the rods at West Albany is worthy of note, in view of the excellent results obtained. The heads are heated in a specially constructed furnace and shrunk on to the rod, an allowance of 1/80 in. to the foot being made; the piston rod nut is applied as usual in other shops. This method has proved very effective in reducing the number of loose heads and when removing a head from a rod, it is necessary to do so in the big wheel press, often requiring a pressure of 200 tons.

Planing Shoes and Wedges.—Exceptionally good work is being done on the shoe and wedge planer shown in Fig. 12. The operator has so familiarized himself with the work and the best methods of grinding and setting up his tools, that he is able to machine the driving box fit on about forty shoes and wedges a day. Referring to the illustration, he will be seen taking a cut 1 3/8 in. deep in one operation. No finishing cut across the shoe is necessary. The cut shown is about all the machine will stand and could not be taken unless the tool was ground and set properly.

AIR BRAKE REPAIRS

The method of making air brake repairs is not materially different from that at other shops, but the output is excep-

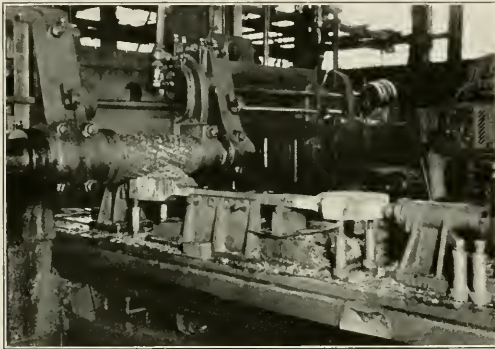

Fig. 8—Milling Side Rods

tionally good, considering the number of men employed. Five men working on No. 5 New York Duplex air compressors repair from 45 to 50 a week or an average of almost two pumps a day per man. As these compressors are rated at \$4.39 a piece complete, it will be seen that the men are making very good pay, but it is also true that a man who did not understand the work could hardly repair one pump a day and even that might be rejected on account of not standing the test. The entire question hinges on the fact that a capable mechanic who works on the same job long enough will systematize his work, will know just how accurately it must be done and make no lost motions. The result is that he accomplishes more and with apparently less effort than another mechanic who is perhaps a good man, but inexperienced.

All of the foundation brake rigging is handled and repaired in this department and there is a considerable saving due to having the job localized and not trucking the parts back and forth through the shop. All of the valves, such as brake valves, triple valves, feed valves, straight air brake valves, etc., are repaired by three men, who also are experienced men and make every move count.

The test rack was designed by the air brake foreman and is considered one of the most complete racks in use. It is fitted to test any and all of the air brake valves that are used on the New York Central equipment. An attempt has been

made to establish, as near as possible, service conditions and the compressor supplying air is arranged to give 140 lb. pressure. The reservoirs are of the same capacity as those used



Fig. 9—Turning Driving Boxes on Gisholt Boring Mill

on the locomotives and there is sufficient piping to give the train-line the capacity of a 50-car train. The signal line piping has the capacity of a 25-car train, and by means of

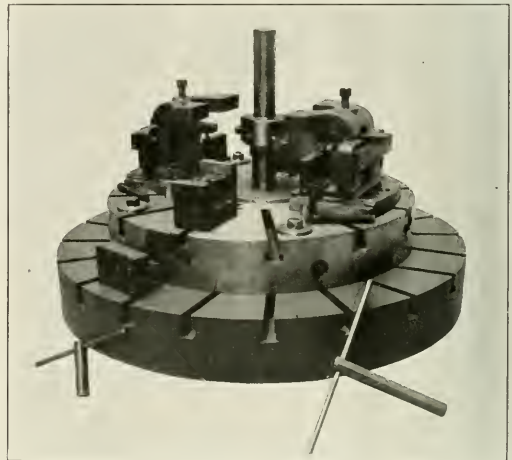

Fig. 10—Special Chuck Used on Gisholt Machine

ingenious arrangements of clamping, it is possible to test any part of the air brake equipment quickly and conveniently.

TOOL ROOM

The tool room at West Albany is a large one and formerly employed 35 men, but under the leadership of the present

foreman and the inspiration of his methods of working, the present force of 16 men does all of the work. The tool room must be prepared to make repairs on all of the machinery, shuffling, cranes, etc., at West Albany in addition to considerable roundhouse work and new work, such as dies, milling cutters and new jigs. In the past seven years probably 860 sets of dies have been made. That this work can be done with a reduced number of men is largely due to the foresight of the foreman, who plans ahead and tries to be prepared beforehand for all emergencies. The tool room is

a brass casting may be made in the foundry and machined. One of the main reasons for the success of the brass room has been the standardization of tools and equipment. Most of the machine work is handled by four Fox lathes, all of which are alike and have interchangeable chucks, tools and jigs. The advantage of this arrangement will be evident to all who are familiar with the loss due to duplicating equipment.

BOILER SHOP

The boiler shop work at West Albany is strictly up to date and very seldom is a locomotive held up for the lack of a boiler suitably repaired to go into service. Take for example the method of constructing a firebox after it is laid out and punched. The entire list of operations from shearing, scarfing, rolling and chipping the flanges, to riveting, caulking and putting the box into the casing, are often performed in 10 hours. Holes are laid out and punched beforehand, no time is lost in fitting and every man knows his job.

The work in the tube shop is interesting on account of the fact that no new tubes have been bought for four years. This has been made possible by the use of a reclaiming machine which was built by the shop men and is used to weld the tubes in the center. Thus two old tubes that have been safe-ended four or more times have the safe ends cut off and are welded together at the center to make one new tube. If this tube is to be used in passenger service, it has to be steel safe-ended. All tubes are tested under compression at 600 lb. The method of handling superheater flues is also

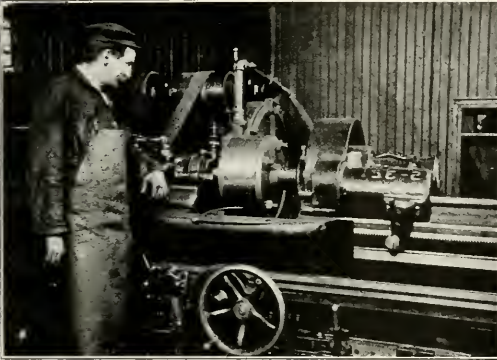

Fig. 11—Grinding Piston Valve Packing Rings

well equipped with modern machinery and one of the most interesting is a surface grinder equipped with a magnetic chuck. This machine is used in the manufacture of straight edges, gages, dies, etc., also in the case of broken axles, when it is desired to examine the structure of the steel, a sample piece is usually slotted off and then ground to a perfectly true surface on this machine.

BRASS ROOM

The work in the brass room is handled by 16 men, mostly specialists. The injector job in particular is noteworthy,



Fig. 13—Testing Superheater Flues

of interest and special machines have been developed for welding and testing. Fig. 13 shows the machine used in testing and the method is as follows: The safe-ended superheater flue is placed in the machine and firmly held at the left hand end. The right hand end is supported and firmly clamped in a carriage which is free to move on small roller wheels. Both ends are plugged by air operated caps, the water for testing being admitted through the left hand plug. The pressure is then raised to 250 lb. and inasmuch as the right hand support is free to move, the result is that the flue is subjected to a tension equal to 250 lb. times the cross sectional area of the flue. This test approximates service conditions and has proven very satisfactory.

The boilers are usually washed out at night and as a rule ten boilermakers are employed at night to help out on any work that may have been delayed.

BLACKSMITH SHOP

The spring work is done in the smith shop. Adequate machinery is provided so that six men are able to turn out from 1,500 to 1,800 springs per month. An efficient stripping machine is used in removing the bands and with this machine it is possible to remove even the heaviest bands quickly and without damaging them. The banding machine provides a pressure of 100 tons and compresses the sheaves



Fig. 12—Machining Shoes and Wedges

because practically all of the injectors including those sent in from roundhouses are repaired by one man. He has been 20 years with the company and spent most of that time on the injector job. On account of his ability and knowledge of the work he can repair from 30 to 35 injectors a week. Most of the repair parts in the brass room are carried in stock and are not made up from new material unless they happen to be out of a particular part needed, in which case

as it presses the band around them. The testing machine is conveniently placed and each spring is tested to see that it conforms to the specifications.

In view of the extreme importance of keeping down drawbar failures, the New York Central has specified that only the best hammered iron should be used in making them, and drawbars are made from home-made billets. The following method of making the billets is used: The best quality of iron is bought made up in the form of 4-in. by 1-in. bars and cut up into 8-in. and 16-in. lengths, being made into piles about 14 in. high. The piles are put in the furnace and heated to a welding temperature and are hammered into shingles, which are usually about 1½ in. by 14 in. by 4 ft. The shingles are then welded together, enough being used to give a billet of the required thickness. By this method well hammered stock of the first quality is obtained for making drawbars, crank arms, valve motion work, etc. A comparison of relative costs, including the cost of new material, cutting, shingling and making into billets indicates that there is perhaps little saving in this method, but the best quality of stock is obtained, and when it is wanted, which is not always possible when purchasing on the open market. In case the welded shingles are forged immediately the cost is less.

A special upsetting and lengthening machine, shown in Fig. 14, is in use in this shop and aids very materially on certain kinds of work. This was devised by Mr. Stock, the assistant blacksmith foreman. It is provided with four vertical cylindrical posts set eccentric, so that with any work placed between them, the harder it is pulled apart, the tighter it becomes between the posts. Power is applied by means of an hydraulic ram operated by a small Westinghouse air compressor which has been reconstructed for this purpose. The machine may be used effectively in lengthening or shortening side rods, because it is not necessary to heat the rod above a dull red and thus change the structure and physical qualities of the steel. Drawbars may also be lengthened or shortened on this machine. No tram is necessary, as the gage shown in the illustration indicates at a glance just how much the material has been upset or lengthened. That this machine is a time saver is shown by the reduction of 45 per cent in piece



Fig. 14—Upsetting and Lengthening Machine

work prices since its installation. A description of the blacksmith shop would be incomplete without mention of the two die racks and the extensive assortment of dies, which is estimated to be worth at least \$30,000. These are not obsolete dies that have been collecting, but are in continuous use in the forging machines for making the many different parts manufactured in this way.

TANK AND TRUCK SHOP

The importance of having ample floor space for tank work is proved by the increase in output due to the construction of the new tank shop at West Albany. The capacity of this shop is practically 100 tanks a month and here again, the

electric welding process has had an important part to play. In case the back end of a tank is wrecked, the whole end is cut off with the acetylene torch, removed, straightened and put up again, with a T-iron on the inside to break the joints.

In the truck shop there is a large journal lathe which is set below the level of the floor so the wheels may be easily rolled on to the lathe and the journals turned without removing the wheels. It handles about 500 pairs of wheels a month.

ERECTING SHOP

With 40 working pits the average output of the two erecting shops is over two locomotives a pit a month and it would be possible to obtain three instead of two provided the



Fig. 15—Apprentice Schoolroom at West Albany

capacity of the machine shop could be increased. Under the present system the heavy repair locomotives are usually on the pit about eight days, but some take longer than this and on the other hand, when a locomotive comes in in especially good shape, it is often possible to so speed up the machine work that the locomotive is returned to service in less than eight days. A recent example of the quick work done in the erecting shop was the delivery of a boiler and the placing of it in the frames Thursday morning, and the completion of work by Saturday noon. During that time the boiler received its test and had all leaky tubes removed and renewed. As stated under the subject of electric welding, the extent to which this process has been developed is largely responsible for the good showing of the erecting shop.

APPRENTICE SCHOOL

The method of instructing the apprentices at West Albany is particularly good. The chief draftsman instructs the boys in the principles of mechanical drawing, drawing of details, freehand sketching and tracing when the boy shows especial aptitude. Two hours a day, twice a week, are allowed the boys for classroom work and they are paid for this time at their regular rates. The last half hour of each period is devoted to class problems in arithmetic and certain of the simpler laws of mechanics, such as the law of levers, the inclined plane and the relation of pulley diameters to respective speeds, are carefully explained.

The classroom is well supplied with models, as shown in Fig. 15 and those models applying to the shop work include a Walschaert valve gear, a Baker Pilliod valve gear and a model to be used in lining shoes and wedges, and guides. This work comes under the direction of the shop instructor, who has held the position for nine years and understands not only what the boys should be taught, but how to present it in an interesting way. One thing which has proved very beneficial to the boys has been the assignment of home work from a text book used in conjunction with shop work. For instance, if the boy is working on a planer, he is assigned a certain lesson from a text book which deals with planer con-

struction and operation and such problems as may arise. At the present time the apprentice school includes 101 boys and so far as possible each one is given personal instruction. It is obviously impossible, even in a four year course, to give the boys a comprehensive knowledge of all the work done in the shop, but they are placed with the best mechanics and given every opportunity to improve in judgment and knowledge as they go from job to job. As usual most of the apprentices are working to become machinists.

That the possibilities for a bright, ambitious boy are good in the apprentice school, is illustrated by the case of one

boy who in slightly less than three years after completing his apprenticeship has become a foreman in the boiler shop.

CONCLUSION

Locomotives are needed now and will be needed more next winter. They are needed for the support of our industries and the carrying out of a successful war program. That West Albany is doing much to forward this program cannot be denied and the way it is done is by the co-operation of an able management with earnest workmen, all of whom are using their heads and pulling together.

WAGE INCREASE FOR RAILWAY MEN

A Minimum Hourly Wage of Fifty-Five Cents for Mechanics Allowed—Dissatisfaction Among the Men

THE news from the Railroad Administration at Washington during the past month of most interest to railway employees was the announcement of the findings of the Railway Wage Commission. The commission recommended increases estimated to amount to about \$300,000,000, reaching the conclusion that the fairest method of dealing with the problem was to award increases on a percentage scale ranging from \$20 a month for those receiving \$46 a month and under down to \$1 for those receiving \$249. These percentages were based on the scale of December, 1915, and any increases since that time were to apply on the commission's scale. But the important proviso was included that reductions in hours were not to be regarded as increases in pay, thereby giving the men in train service additions under this scale to those obtained through the eight-hour law.

The commission's recommendations were made after an exhaustive investigation of the increased cost of living; it was found, for example, that each dollar now represents in power to purchase a place to live, food to eat and clothing to wear but 71 cents as against 100 cents on January 1, 1916.

The commission's suggested scale is as follows, the amounts by \$5 divisions only being shown:

THE SCALE RECOMMENDED

1	2	3	4
To the monthly rate of pay of men receiving in December, 1915, the amounts named in this column	Add the per cent gained in this column	Equivalent to amount named in this column	Making new rate per month as shown in this column
Under \$ 46.00	\$20.00
\$ 46.01 to 47.00	43.00	\$20.00	\$ 67.21
50.01 to 51.00	42.35	21.60	72.60
55.01 to 56.00	41.00	22.96	77.96
60.01 to 61.00	41.00	25.01	86.01
65.01 to 66.00	41.00	27.06	93.06
70.01 to 71.00	41.00	29.11	100.11
75.01 to 76.00	41.00	31.16	107.16
80.01 to 81.00	40.44	32.75	113.75
90.01 to 91.00	36.38	33.10	124.10
100.01 to 101.00	31.29	31.60	132.60
110.01 to 111.00	27.12	30.10	141.10
120.01 to 121.00	23.64	28.60	149.60
130.01 to 131.00	20.69	27.10	158.10
140.01 to 141.00	18.16	25.60	166.60
150.01 to 151.00	15.96	24.10	175.10
160.01 to 161.00	14.04	22.60	183.60
170.01 to 171.00	12.34	21.10	192.10
180.01 to 181.00	10.83	19.60	200.60
190.01 to 191.00	9.48	18.10	209.10
200.01 to 201.00	8.26	16.60	217.60
210.01 to 211.00	7.16	15.10	226.10
220.01 to 221.00	6.15	13.60	234.60
230.01 to 231.00	5.24	12.10	243.10
240.01 to 241.00	9.00	250.00
249.01 to 250.00	00	250.00

All advances suggested are effective January 1, 1918, and are retroactive. The back pay due on June 1 is estimated at \$125,000,000.

The Director General approved these recommendations with certain changes in General Order No. 27 issued May 25.

The most important of these changes from the mechanical department standpoint is one establishing a minimum rate of 55 cents an hour for machinists, boiler makers, blacksmiths, and other mechanics who receive the same basis of rates. Common labor is granted an increase of 2½ cents an hour in excess of the rate on December 31, 1917. Another marked deviation from the recommendations of the Railway Wage Commission is one wherein the basic eight-hour day is established. This does not reduce the hours of employment as at present worked, nor does it increase the total compensation fixed in the order for the number of hours now worked in excess of eight hours, but it does establish the basic

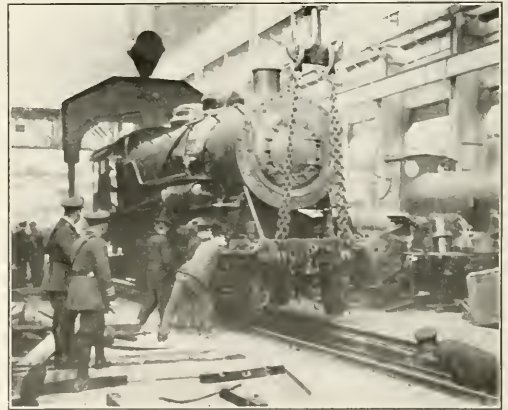

Copyright by Underwood & Underwood.
The Successful Outcome of the War Depends No More Upon These Men Than Upon Railway Shop Men at Home

eight-hour day upon which further wage adjustment may be based. The order of the Director General also creates an advisory board of Railroad Wages and Conditions consisting of J. J. Dermody, F. F. Gaines, C. E. Lindsey, W. E. Morse, G. H. Sines, and A. O. Wharton, of which Mr. Sines was appointed chairman.

Sections C and D of the Director General's order deal respectively with hourly and piece work scales, principally of the shop trades are reproduced in part herewith:

While it is expected that the Board of Railroad Wages and Working Conditions hereinafter created shall give consideration to all questions of inequality as between individ-

uals and classes of employees throughout, sufficient information is available to justify certain conclusions with respect to the mechanical crafts, and in the case of machinists, boilermakers, blacksmiths, and other shop mechanics who have been receiving the same hourly rates, the increases named in this order shall apply, with a minimum wage of 55 cents per hour. It is recognized that this may still leave among shop employees certain inequalities as to individual employees, to which the Board of Railroad Wages and Working Conditions will give prompt consideration.

SECTION C.—RATES OF WAGES OF RAILROAD EMPLOYEES PAID UPON HOURLY BASIS.

		[Rates of pay in cents per hour.]							
Old rate per hour ¹	New rate per hour	Old rate per hour ¹	New rate per hour	Old rate per hour ¹	New rate per hour	Old rate per hour ¹	New rate per hour	Old rate per hour ¹	New rate per hour
10	19.75	38	53.75	66	78.50	94	102.50		
10.5	20.25	38.5	54.25	66.5	79.00	94.5	102.75		
11	20.75	39	54.75	67	79.50	95	103.25		
11.5	21.25	39.5	55.50	67.5	79.75	95.5	103.75		
12	21.75	40	56.00	68	80.25	96	104.25		
12.5	22.25	40.5	56.75	68.5	80.75	96.5	104.50		
13	22.75	41	57.25	69	81.25	97	105.00		
13.5	23.25	41.5	57.75	69.5	81.50	97.5	105.50		
14	23.75	42	58.25	70	82.00	98	106.00		
14.5	24.25	42.5	58.50	70.5	82.50	98.5	106.25		
15	24.75	43	59.00	71	83.00	99	106.75		
15.5	25.25	43.5	59.50	71.5	83.25	99.5	107.25		
16	25.75	44	60.00	72	83.75	100	107.50		
16.5	26.25	44.5	60.25	72.5	84.25	100.5	108.00		
17	26.75	45	60.75	73	84.50	101	108.25		
17.5	27.25	45.5	61.25	73.5	85.00	101.5	108.75		
18	27.75	46	61.50	74	85.50	102	109.25		
18.5	28.25	46.5	62.00	74.5	86.00	102.5	109.75		
19	28.75	47	62.50	75	86.25	103	110.00		
19.5	29.25	47.5	63.00	75.5	86.75	103.5	110.50		
20	29.75	48	63.25	76	87.00	104	111.00		
20.5	30.25	48.5	63.75	76.5	87.50	104.5	111.25		
21	30.75	49	64.25	77	88.00	105	111.75		
21.5	31.25	49.5	64.75	77.5	88.25	105.5	112.25		
22	31.75	50	65.00	78	88.75	106	112.75		
22.5	32.25	50.5	65.25	78.5	89.25	106.5	113.00		
23	33.00	51	65.75	79	89.75	107	113.50		
23.5	33.75	51.5	66.25	79.5	90.00	107.5	114.00		
24	34.50	52	66.50	80	90.50	108	114.25		
24.5	35.00	52.5	67.00	80.5	91.00	108.5	114.75		
25	35.50	53	67.50	81	91.50	109	115.25		
25.5	36.00	53.5	68.00	81.5	91.75	109.5	115.75		
26	36.75	54	68.25	82	92.25	110	116.00		
26.5	37.50	54.5	68.75	82.5	92.75	110.5	116.50		
27	38.25	55	69.25	83	93.00	111	117.00		
27.5	39.00	55.5	69.75	83.5	93.50	111.5	117.25		
28	39.50	56	70.00	84	94.00	112	117.75		
28.5	40.25	56.5	70.50	84.5	94.50	112.5	118.25		
29	41.00	57	71.00	85	94.75	113	118.50		
29.5	41.75	57.5	71.50	85.5	95.25	113.5	119.00		
30	42.50	58	71.75	86	95.75	114	119.50		
30.5	43.00	58.5	72.25	86.5	96.00	114.5	119.75		
31	43.75	59	72.75	87	96.50	115	120.00		
31.5	44.50	59.5	73.00	87.5	97.00	115.5	120.00		
32	45.25	60	73.50	88	97.25	116	120.00		
32.5	46.00	60.5	74.00	88.5	97.75	116.5	120.00		
33	46.75	61	74.50	89	98.25	117	120.00		
33.5	47.25	61.5	74.75	89.5	98.50	117.5	120.00		
34	48.00	62	75.25	90	99.00	118	120.00		
34.5	48.75	62.5	75.75	90.5	99.50	118.5	120.00		
35	49.50	63	76.00	91	99.75	119	120.00		
35.5	50.25	63.5	76.50	91.5	100.25	119.5	120.00		
36	51.00	64	76.75	92	100.75	120	120.00		
36.5	51.50	64.5	77.25	92.5	101.25				
37	52.25	65	77.75	93	101.50				
37.5	53.00	65.5	78.25	93.5	102.00				

¹Old rates¹ are those of December, 1915.

The rate of pay for this position in 1915 was 34 cents per hour; new rate under this order, 48 cents per hour, but with minimum rate of 55 cents per hour as herein ordered will receive..... \$143.00
In January, 1918, his rate of pay was 37½ cents per hour; 260 hours equals..... 97.50

Difference one month..... \$45.50
On basis of working same amount of straight time each month for 5 months (January 1 to May 31)..... 227.50
Also worked in same period 90 hours overtime at pro rata rate, with 55-cent minimum rate, equals..... \$49.50
Was paid at 37½-cent rate pro rata overtime or..... 33.75

Balance due January 1 to May 31, 1918..... \$243.25

(3) Machinist "D" was employed in the same shop in December, 1915, and in 1918 on the same class of work. His hourly rate in December, 1915, was 35 cents for 9 hours, 26 days a month. He was paid for overtime and Sunday work at time and one-half. On January 1, 1918, his hours were reduced to 8 and his rate increased to 40 cents. The new hourly rate applicable to his 1915 rate, viz.: 49½ cents being less than the minimum of 55 cents, his new rate will be 55 cents per hour. In 1918, from January 1 to May 31, he worked 234 hours per month or an average of one hour overtime daily on the 1918 schedule. This for five months gives him 130 hours overtime. He has been paid as follows:

1,040 hours straight time, at 40 cents..... \$416.00
130 hours overtime, at 60 cents..... 78.00
Total..... \$494.00

His back pay will be computed as follows:

1,040 hours straight time, at 55 cents..... \$572.00
130 hours overtime, at 82½ cents..... 107.25
Total..... \$679.25

Deduct payment at 1918 rates..... 494.00
Back pay due..... \$185.25

and his future rate per hour will be 55 cents.

(4) In the case of employee "E," who was employed in a shop where the rate for his position was 35 cents per hour for 8 hours' work in 1915, with time and one-half for overtime, but in the same position and same shop with the same hours in 1918 his rate is 45 cents per hour; his earnings in 1915 in the standard 208-hour month would be \$72.80 per month, and he would be entitled to the new hourly rate of 49½ cents per hour. His straight time and overtime earnings and back pay would be computed in exactly the same manner as machinist "D." The principles illustrated will apply to all men paid by the hour, whatever their occupation may be.

METHOD OF APPLYING INCREASES TO PIECE RATES

(1) The piecemaker shall receive for each hour worked, the same increase per hour as is awarded to the hourly worker engaged in similar employment in the same shop.

(2) If the hourly rate has been increased since 1915 to an amount greater than the increase herein fixed, then the higher rate shall prevail.

(3) Where there was no piece rate for an item or operation in the piece-rate schedule of 1915, adjust the current price by such an amount as a similar item or operation has been increased or decreased since December 31, 1915, or as near such a plan as practicable.

(4) It is understood that the application of this order shall not, in any case, operate to reduce current earnings.

(5) When a piecemaker works overtime or undertime, he shall receive that proportion of the increase provided in the schedule which the time actually worked bears to the normal time in the position.

(6) Overtime is not to be considered solely as the number of hours employed in excess of the normal hours per month in the position, but rather the time employed in excess of the normal hours per day.

(7) Employee "F" was employed under a piecework schedule in a shop where the basic hourly rate was 35 cents for eight hours, with time and one-half for overtime. This rate under the plan illustrated above will be increased to

For common labor paid by the hour, the scale named herein shall apply with the provision, however, that as a minimum, 2½ cents per hour will be added to the rates paid per hour, as of December 31, 1917.

METHOD OF APPLYING INCREASES TO HOURLY RATES

(1) Machinist worked in January, 1918, eight hours per day, 27 days, total 216 hours straight time.

The rate of pay for this position in December, 1915, was 34 cents per hour; new rate under this order 48 cents per hour, but with minimum rate of 55 cents per hour as herein ordered, will receive \$118.80
In January, 1918, his rate of pay was 37½ cents per hour, for 216 hours, equals..... 81.00

Difference one month..... \$37.80
On basis of working same amount straight time each month for five months (January 1 to May 31)..... 189.00
Also worked in same period 90 hours overtime at time and one-half, new 55-cent minimum rate, or 82½ cents, equals \$74.25
Was paid at 37½-cent rate pro rata overtime or..... 33.75

Balance due January 1 to May 31, 1918..... \$212.62

(2) Machinist worked in January, 1918, 10 hours per day, 26 days, total 260 hours straight time.

49½ cents per hour. The difference is 14½ cents per hour. Regardless of the schedule of piece rates under which he is paid, under this order "F" will be entitled to receive 14½ cents per hour in addition to his piecework earnings for every hour worked in 1918 unless the hourly rate shall in the interim have been raised and a proportionate increase made in the piecework schedule.

For example: Assume that "F" made \$90 in December, 1915, at his piecework. At the hourly rate he would have earned only \$72.80, and his hourly rate must therefore be increased to 49½ cents.

If, in January, 1918, he has attained sufficient skill to earn \$100 on the same piecework schedule, he will be entitled to receive, nevertheless, 14½ cents per hour for each hour of straight time worked, and for each hour of overtime, 21¾ cents additional (if time and one-half for overtime is in effect).

Assume that in the five months, January 1 to May 31, "F" has worked 1,040 hours straight time, and 130 hours overtime, and has, at his piece-work schedule, earned \$500.

had not been raised in the interval. This man earned in 208 hours \$100. He is entitled to a raise of 11¾ cents per hour.

11¾ cents × 208	
1 month	\$24.44
5 months	122.20

DISSATISFACTION WITH THE INCREASES ALLOWED

Very regrettable demonstrations against the increases allowed have taken place on the Southern at Alexandria, Va., and on the Rock Island at Silvis, Ill., where the men actually struck. This was particularly uncalled for as the director general had taken pains to form a new board consisting of representatives of the Brotherhood of Railway Trainmen, Railway Telegraphers and the head of the Railway Employees' Department of the American Federation of Labor, together with ex-railroad men, to consider and pass upon all petitions and complaints regarding the working out of this new wage plan. The director general was very rightly disturbed at the action of these employees and sent the following message to the heads of the organizations of the railroad shop men, including the Metal Workers' International Al-



Copyright by Underwood & Underwood.

Railway Shop Men of the British Army in France—These Men Are Working on Army Pay; They Will Not Strike!

He will be entitled, nevertheless, to receive as back pay, the following amount:

1,040 hours at 14½ cents per hour.....	\$150.80
130 hours at 21¾ cents, per hour.....	28.28
	\$179.08

But if in January, 1918, the basic hourly rate had been increased to 50 cents, and this increase had been correspondingly expressed in his piece-work schedule, he would be entitled to no back pay. If, on the other hand, the hourly rate had been increased from 35 cents in 1915 to 45 on January 1, 1918, and this increase had been expressed in a corresponding increase in the piece-work schedule, then "F" would be entitled to receive back pay at 4½ cents per hour for straight time and 6¾ cents per hour overtime.

If the practice in the shop, however, had been to pay pro rata for overtime, then the rate for such overtime since January 1, 1918, would be pro rata at 4½ cents, or 14½ cents per hour, according to whether piece rates had been or had not been increased.

(8) Employee's December, 1915, rate was 38½ cents; which rate in this order for 8 hours per day entitled him to 54¾ cents per hour. His basic rate had, by January 1, 1918, been raised to 42½ cents per hour. Piece work rates

of the International Brotherhood of Electrical Workers of America, American Federation of Labor and Amalgamated Shopmen's Machinist Organizations:

DIRECTOR GENERAL MCADOO'S MESSAGE

"The strike of certain shopmen, machinists, etc., in the railroad shops at Alexandria, Va., has created a very painful impression on the public mind. I cannot believe that these men knew what they were doing. They are all employees now of the United States government. They are not employees of any railroad corporation, therefore this was a strike against the government of the United States. It is the first time in the history of our government that any of its employees have attempted a strike against their government. Such action is incredible. For the good of our beloved country and for the honor of railroad men in the service everywhere I hope that there will be no repetition of what everyone must condemn as unpatriotic in the highest degree.

"The government cannot, of course, be coerced or intimidated by any of its employees. It is anxious to do justice to all and will do justice to all as far as it is possible to measure justice. Recognizing that there are probable inequalities in the recommendations of the Wage Commission

which should be impartially considered and dealt with, I appointed in my General Order No. 27, dated May 25, a board of railroad wages and working conditions composed of three representative labor men and three representative railroad men, whose duty it is to hear and to pass upon all petitions and complaints. Every class of employees or parts of classes of employees who feel that they have just ground for complaint under the wage decision should submit their cases promptly to this board and they will be given just and impartial consideration. The American people have just been called upon to pay largely increased freight and passenger rates for the purpose of paying in part the increased wages, amounting to more than three hundred million dollars, awarded to railroad employees.

"Suppose they should strike against the government because they do not think they are fairly treated in being forced to pay these increases for the benefit of railroad labor, what would happen to our country? Suppose that railroad officers should strike because they dislike the orders of the government and should refuse to obey them, what would happen to them? Suppose that railroad employees should strike against the decisions of their government and hamper the operation of the railroads at a time when transportation is essential to protect the hundreds of thousands of American boys now fighting on the battle fields of Europe to save the lives and property and liberty of railroad employees serving here at home, what would happen to our country?"

"The Kaiser would probably get it. We cannot all get exactly what we want in this world, nor can we win this war unless each and every citizen is willing to submit to the laws of the land and to the decisions of those in authority.

"We railroad men particularly must give unswerving and loyal support to our government, no matter what our individual views and disappointments may be, relying upon a fair hearing of our complaints and the justice of our cause and accepting patriotically the final decisions of those in authority who, under our laws, are charged with the responsibility of making them.

"While in the German drive now going on the sons of railroad men and the sons of Americans of every class are dying on the battle fields of France to save America and democracy in the world, shall there be found among us any man or set of men who are unwilling to sacrifice something of their personal views and individual desires to support America's heroes who are making the supreme sacrifice for us? I earnestly hope that from one end of this great land to the other it may never be said again that any railroad man, officer or employee, was so unpatriotic as to strike against his own government when it is in the midst of the most perilous war of all history. It is the highest duty of patriotic men to remain at their posts with the railroads, where they are so urgently needed for the safety of the country, and to rely upon the board of railroad wages and working conditions and the director general for the just consideration of their claims. I am sure that I can count upon you to immediately urge upon your men by wire the wisdom and patriotism of the course I have suggested."

LABOR REPRESENTATIVES MAKE DEMANDS

On June 3 representatives of 500,000 railway shop men appeared before the Board of Railroad Wages and Working Conditions with a request for a minimum wage of 75 cents an hour for machinists, blacksmiths, sheet metal workers, electricians and car men with four years or more experience, and boilermakers, and a minimum of 56¼ cents for car men with less than four years experience. The eight-hour standard day was requested, six days work a week and time and a half for overtime; these demands representing an increase of about 40 per cent above existing wages.

Director General McAdoo later issued General Order No. 29 creating a commission to be known as Railway Board

of Adjustment No. 2 to consist of 12 members, six to be selected by the regional directors and one each by the chief executive officer of the Railway Employees' Department of the American Federation of Labor; the International Association of Machinists; the International Brotherhood of Boilermakers, Iron Shipbuilders and Helpers of America; the International Brotherhood of Blacksmiths and Helpers; the Brotherhood of Railway Carmen; the Amalgamated Sheet Metal Workers' International Alliance, and the International Brotherhood of Electrical Workers. This board will adjust all controversies growing out of the interpretation or application of the provisions of wage schedules or agreements which are not promptly adjusted by the officials and employees of the roads operated by the government.

THE RAILWAY INDUSTRIAL ARMY*

BY W. S. CARTER

We are told by those who know that it requires four tons of shipping to maintain one American soldier in France. We are told by those who are determined to win the war that by the spring campaign of 1919 we will have more than two millions of our boys "over there," and as the war progresses more and more ships will be required to transport across sea food and munitions with which to maintain our fighting force. Not only the winning of the war depends upon this ceaseless flow from our farms and our factories to the battle front, but, without it, the men we send to France in freedom's cause will be sacrificed.

When we talk of this stupendous movement of war supplies we seem to think only of ships, but little thought is given to the fact that upon our railroads these ships must depend for cargoes and bunker coal. The reason that we have not more fully recognized this fact is because heretofore the capacity of our railroads has exceeded that of our ships. We read from day to day of the splendid developments of the shipbuilding industry, and the day is not distant when our ports will be crowded with ships in readiness to perform their part in this great transportation problem. When that day comes we railroad men will have a rude awakening. No longer may we conduct our business affairs and maintain our conditions of labor as in the days of peace.

Without yielding their laudable purpose to limit a day's work to eight hours when this war is over, the American working people must now work as long each day as the war's necessities demand, compatible with their physical well-being. So long as brothers and sons of American working people are dying in France for our liberty none of us will hesitate short of our greatest effort. Business men must no longer profit out of our country's misfortunes. Great wealth accumulated during this war will not be the product of patriotism. With millions of men now under arms in France, with thousands of ships ready for cargoes and bunker coal, railroad men will soon realize that truly they are a component part of the American expeditionary forces. In fact, they are now a great industrial army. Their failure to maintain an efficient line of transportation will cause ships to lie idle in our harbors and deprive our battle line of munitions and food.

A breakdown in the efficiency of our railroads here when the crisis comes will be no less disastrous than a rout of one of our armies in the great battles that must be fought before the war is won. I shall not attempt to tell each railroad man what he should do to avert the possible collapse of our transportation system when it is put to a crucial test. Each and every railroad man's conscience will tell him that.

I know that the railroad employes of this country will not be lacking in the performance of their duty to the nation and to those who go across the sea to win or die.

*Abstract of a paper presented at the recent convention of the International Railway Fuel Association.

AIR BRAKE CONVENTION PROCEEDINGS

Important Papers Dealt With Prevention of Break-in-Twos and Slack Action in Passenger Trains



SAFETY of train operation and economy in the maintenance of brake equipment to meet war time conditions were the key notes of the twenty-fifth annual convention of the Air Brake Association. The meeting was held at the Hotel Winton, Cleveland, O., on May 7 to 9, 1918. Over 200 members attended. Morning and afternoon sessions were held and all amusement features were eliminated so that all the papers might be presented in two days.

The president, C. H. Weaver, supervisor of air brakes of the New York Central Lines west of Buffalo, in opening the convention, spoke in part as follows:

PRESIDENT'S ADDRESS

At this unusual time, when cars and locomotives are in such great demand and transportation pressure is severe, there is naturally a tendency to slight air brake tests and repair work. This is a grave error. At no time in the history of our association can the air brake man be of such vital importance to his company as at the present period, by seeing that all air brake work is properly performed and no material wasted. Work slighted or improperly done causes failures, which mean delays to traffic and even disaster.

I would suggest that the various air brake clubs throughout the country have their secretaries get in touch with the secretary of the Air Brake Association, to the end that there may be a perfect co-operation between these various organizations and our association. In this way many subjects may be taken up by the clubs and threshed out before being presented to the association.

MR. MACBAIN'S ADDRESS

During the opening session of the convention, D. R. MacBain, superintendent of motive power of the New York Central Lines west, addressed the association. A brief abstract of his address is given below.

A question that is more important than any other thing confronting us at the present time is the maintenance of the air brake equipment on freight cars. The maintenance of the piping, cylinders, connections, etc., on freight car equipment in this country has been given much less than the desired amount of attention, and while we have started along the right line toward improvement, we are not yet to that point of efficiency in the matter of maintenance that is desirable for the proper handling of the freight trains of the present day. This is the field wherein the greatest improvement can be made by this association and its mem-

bers, scattered all over the country as they are. A concerted campaign in the matter of proper piping maintenance, cylinder and triple valve cleaning and slack adjusting will bring such satisfactory results as to warrant any expenditure that may be necessary to that end.

SLACK ACTION IN LONG PASSENGER TRAINS

Slack action shocks may be produced by (a) shutting off the engine-throttle quickly and applying the engine and train brakes somewhat heavily; (b) applying the engine brakes and then the train brakes; (c) trains with brake conditions that produce effective braking power on the engine and head cars in advance of the rear cars; (d) cars in a train having a lower percentage of braking power than the balance of cars, which may be due to their being loaded in one case and empty in another; (e) inability to produce a low-brake cylinder pressure in the beginning of a brake application.

The severity of any shock produced from the above will depend upon the degree in which any of the above mentioned features exist, the number and weight of cars, rate of speed, and amount and rate of producing brake cylinder pressure. Even though all the above conditions do exist, with the exception of (e), if the engineer so manipulates the brake that light brake cylinder pressure will be obtained when the brake application is first started, any slack action that does occur will, of course, occur slowly, and will not be noticeable in the form of shocks. On the other hand, if it is impossible for the engineer to control the brake cylinder pressure in the beginning of the brake application, to provide for a slow movement of the slack in the train, it is necessary to so modify the other features that the handling by the engineer will produce satisfactory results.

Where slack action occurs with uniform piston travel, and shocks are produced during brake applications, it may be brought about by the brakes in one end of the train applying effectively in advance of the brakes on the other end, or by great differences in the percentage of braking power on different cars throughout the train.

Increasing the percentage of braking power on the locomotive and also on the load carrying cars might prevent the slack running out in the form of jerks, but at very low speeds it would increase the tendency for a collision between the head end and rear end of the train unless provision was made to apply the brake so slowly that the slack action would not be noticeable.

Where conditions are such that heavy brake applications

produce unsatisfactory results, it is the practice to slightly increase the time in which the stop is made, by graduating the brake on through light reductions when the application is first started; instead of attempting a stop in thirty-five to forty-five seconds, the time is increased to about sixty seconds. This provides ample time to avoid any noticeable slack action.

A form of foundation brake gear can be employed which will permit of a longer piston travel than is common with the single shoe type if the truck construction is such as to permit of its application. This can be depended upon, with automatic slack adjusters, to maintain the piston travel at practically eight inches without greatly increasing the running piston travel over the standing piston travel, thus insuring a low brake cylinder pressure in the beginning of brake applications, regardless of the speed at which the train is running.

With the single shoe type of foundation brake gear the piston travel may be five inches with 60 lb. in the brake cylinder. When the car is running at a high rate of speed, 60 lb. brake cylinder pressure increases the piston travel to eight inches. At a rate of speed from six to eight miles per hour, a 10-lb. brake pipe reduction may not produce more than four inches piston travel, and the cylinder pressure obtained for this reduction will be from 30 to 35 lb., or twice as much as should be obtained if the piston moved out to eight inches. Under such conditions it is necessary to provide an increased brake cylinder volume in order to permit of a low brake cylinder pressure being obtained in the beginning of brake applications; or to reduce the auxiliary reservoir volume so that the proportion of the auxiliary reservoir and brake cylinder will be such that a low brake cylinder pressure will be possible.

If it is necessary to maintain the same stopping distance, provision must be made to augment the auxiliary reservoir volume so that after the brake application advances sufficiently to provide for the movement of the slack in the train, a higher cylinder pressure, or a higher rate of brake cylinder build-up must be provided for, in order that the final braking power will be sufficient.

If it is necessary to provide short stopping distances for low speeds, when the cylinder volume and reservoir volume are out of proportion, simultaneous application of the brakes throughout the train must be provided for.

If it is impossible to maintain the piston travel sufficiently long to provide for brake flexibility and brake shoe clearance, on account of the action of automatic slack adjusters, it would be necessary to move the slack adjuster connection towards the non-pressure brake cylinder head to provide the desired increased travel. Where excessive false piston travel interferes with the maintenance of the desired piston travel it would be necessary to provide additional movement for the brake piston before striking the non-pressure cylinder head.

If existing types of brake operating equipment are to be maintained intact, the foundation brake gear must of necessity be modified, and any change should contemplate a brake gear that will provide the minimum amount of false piston travel.

Taking into consideration the present conditions with regard to brake equipment, it is necessary that instead of applying the brakes to their maximum in one continuous reduction, the reduction should be made so that the brake application will be gradually produced. Enginemen cannot generally be depended upon properly to carry out instructions with reference to brake manipulation, and the brake application should be automatically timed so that the engineer is able to build up the brake cylinder pressure, or the braking power, at a fixed rate to some predetermined point in the application, and that this rate be dependent upon the

operating conditions obtaining on each railroad. Modifying the service brake by increasing the brake cylinder volume or by reducing the reservoir volume can be compensated for by increasing the brake pipe pressure.

Where the single shoe type of foundation brake gear is in common use, and it is the practice to run the piston travel short, necessary shoe clearance is not obtained, with the result that a great many brake shoes are rubbing the wheels hard when the brakes are released. This increases the difficulty of starting the trains over what would obtain if ample shoe clearance was provided on all cars. Increasing the piston travel to provide more flexibility for the service brake, automatically increases the shoe clearance with a consequent reduction in slack action and in the power necessary to start and propel the train. Increasing the piston travel also automatically reduces the difficulty of releasing brakes, because it necessitates slightly heavier applications to produce effective braking power. Heavier applications of the brakes tend to insure against the difficulty in starting trains which arises when stops have been made from low speeds with light brake applications.

At the Atlanta convention an attempt was made to draw a distinction between inherent and contingent limitations in brake equipment for passenger service. It will be agreed that maintenance and manipulation are contingent limitations, and that each should be kept up to the highest order of efficiency. But it is our duty to recognize and extend the fundamental limitations to obtaining the train operation we should have. It only remains, therefore, that those concerned give the matter sufficient consideration to evolve from the principles here suggested an equipment which will produce satisfactory results.

The report was signed by G. H. Wood, chairman; H. L. Sandhas, M. E. Hamilton, Mark Purcell, H. F. Wood, L. S. Ayer, T. F. Lyons, L. P. Streeter, M. S. Belk, W. J. Hatch, C. H. Rawlings, J. A. Burke, R. C. Burns and Wm. Spence.

DISCUSSION

In the discussion of the report it was brought out that the Santa Fe had reduced break-in-tuos to seven or eight last winter from a total of 75 to 100 during the preceding winter, by making changes in the brakes along the lines suggested in the report. An expedient not mentioned in the paper, which has been adopted on some roads for preventing excessive shocks from the slack run-in on long passenger trains, is the application of the brakes before closing the throttle. This practice has met with considerable success, in that it prevents the too rapid retardation of the locomotive and front end of the train, thereby reducing the velocity difference between the cars in different parts of the train during the time required to build up braking power throughout the length of the train.

Walter V. Turner called attention to the facts that the initial brake pipe reduction in the application of the brakes should never be less than seven pounds. Less than this will not insure the application of all the brakes in the train, some applying and some failing to apply. In case the initial reduction is not followed up with an additional reduction before releasing, some of the brakes which are applied are apt to fail to release, unless a reduction of seven pounds or over has been made. Mr. Turner advocated the testing of the brakes with 15 lb. in the cylinders and the adjustment of the piston travel to seven inches, rather than with a pressure of 60 lb. and eight inches piston travel. He pointed out that it is not with the maximum pressures that the damage is done, but with the low cylinder pressures which, owing to improper piston travel, may be two or three times as high as they should be. If a piston travel of seven inches is secured with 15 lb. in the brake cylinder, it will be im-

possible for the engineer to damage the train through lack of extraordinary skill in manipulation.

THE SAFE LIFE OF AN AIR BRAKE HOSE

At the 1917 convention the committee was instructed to continue their investigation for another year. For the 1918

TABLE I—RECORD OF INSPECTION OF 25,000 AIR HOSE

Group No.	No. hose inspected	No. found porous	Per cent hose porous	Average life of porous hose in months
1	899	93	10.37	26.3
2	8,000	728	9.1	32.9
3	5,026	224	4.0	26.5
4	6,000	2,806	46.0	28.5
5	5,075	1,215	20.2	29.3
Total and average, 25,000		5,066	18.1	28.7

report matter of porous hose has been considered. Records were obtained of 25,000 air hose in service. These were

Every member is well aware of the detrimental effect of brake pipe leakage, but it is possible that due weight may not be given to the effect a few porous hose in a train may have. One of the committee caused five trains to be tested for leakage, inspected for porous hose, and again tested for

TABLE II—EFFECT OF POROUS HOSE ON TRAIN PIPE LEAKAGE

Train No.	Leakage per minute before testing for porous hose	No. hose found porous	Leakage per minute after removing porous hose
1	15 lbs.	6	7 lbs.
2	18 lbs.	5	8 lbs.
3	20 lbs.	8	6 lbs.
4	12 lbs.	6	6 lbs.
5	14 lbs.	7	7 lbs.

leakage, after the porous hose had been removed. The train in each case consisted of 65 cars, and therefore, represented 132 hose, exclusive of those between the engine and tender. The results obtained from these tests were as shown in Table II.



C. H. Weaver (N. Y. C.)
President



F. J. Barry (N. Y. O. & W.)
Vice-President



C. W. Martin (P. R. R.)
Vice-President



F. M. Nellis (Westinghouse Air Brake Co.), Secretary



Otto Best (Nathan Mfg. Co.)
Treasurer

inspected in five different groups, and data in regard to them is given in Table I.

As was found last year, the average life of the air hose still in service was considerably less than that of those which were found burst or porous, this being due to the fact that hose inspected did not burst until they were in service an average of 28½ months, and might reasonably be expected to burst at any time after that length of service. Comparing the average life of the porous hose with the average life of burst hose as inspected last year, there is only a difference of two-tenths of a month.

It is evident that a vast improvement was brought about by inspecting these trains for and removing porous hose, and yet the average number found porous in five trains was only 4.85 per cent of the total number of hose in the train. Remembering that of all hose inspected, the general average found porous was about 18 per cent, we may begin to realize the handicap under which our enginemen and inspectors are working and also the outbound terminal delay due to inaudible brake pipe leakage in the porous hose.

The committee recommends that a system of inspection and soap suds tests on repair tracks, at least, for the pur-

pose of detecting and removing from service all porous hose. The benefit to be derived from this was quite noticeable on one railway. It was found that while the percentage of porous hose ran very high at the beginning, it gradually lessened until within two months, it was reduced to such a point that only 2 per cent of the hose tested were found porous. It was also noticed that outbound terminal air brake delays decreased.

In order to lengthen the life of air brake hose and reduce hose expense the railroads must do one of three things: either put into effect a rule which will cause the hose to be parted by hand, buy a guaranteed hose from the manufacturer, or take up the use of properly constructed braided hose. The two latter items slightly increase the first cost of hose, but reduce the ultimate cost, while for the first item it is an open question whether or not any rule which demands the parting of hose by hand can be universally enforced.

Under present conditions, notwithstanding the fact that some hose have shown a very long term of service, we cannot depend on the average hose remaining in service for a longer period than 28½ months. After that period great numbers of hose are porous and liable to burst under normal pressure at any time.

The report was signed by M. E. Hamilton, chairman; George W. Noland, Joseph W. Walker, M. S. Belk.

DISCUSSION

The principal point brought out in the discussion of this paper was that the most common cause of the destruction of air brake hose is the failure to part the hose by hand before the cars are separated. That the automatic parting of the hose coupling is a severe strain upon the hose is evidenced by the fact that this often results in pulling out or breaking off the train-pipe. The difficulty in overcoming this source of hose destruction lies in the impossibility of enforcing the rule for yardmen and trainmen to part the hose by hand. The only other solution suggested was to put inspectors on to cut all the hose, a practice which is followed in many places. It was suggested that the money spent in this way would be returned many-fold by the reduction in the cost of brake hose renewals and repairs.

The association adopted a motion recommending to the Train Brake and Signal Committee of the Master Car Builders' Association that the safe life of an air brake hose be placed at 28 months.

PREPARING AIR BRAKES AT TERMINALS

Installation.—The brake cylinder and auxiliary reservoir should be bolted to the most rigid portion of the underframe and all points of fastening should be equally rigid to avoid twisting or cramping strains. Air brake piping should be securely clamped to prevent shifting when cars are subjected to shocks. This will avoid many broken or distorted cross-over pipes, loose pipe joints and other causes that produce excessive leakage.

Maintenance.—It is not necessary that the men in charge of air brake maintenance be able to trace the course of the air through all the valves or know the size, location and duty of the ports and passages, but the test rack operator and the men doing the repair work should have sufficient knowledge to tell what effect an ordinary defect will produce.

If the man in charge is to be successful in supervising air brake work he should know, when a triple valve is applied to a car, that it has been properly repaired, cleaned and tested and is suitable for service. A brake tested by making a service application at the proper rate will often fail to apply or remain applied, while if tested by making the reduction at an excessive rate, but less than required to produce an emergency application, the brake will apply and

remain applied. Hence, the importance of testing brakes with a service reduction at the proper rate.

There is no economy in re-applying triple valve gaskets that have become hardened, cracked or disfigured so that they are likely to cause leaks, as the extra labor involved in removing them will more than equal the cost of new gaskets.

The application of levers of improper dimensions and proportions cause brake-rigging failures, slid flat wheels, improper and unequal braking power. Changing brake shoes without readjusting the piston travel is often the direct cause of slid flat wheels and break-in-twos. Permitting cars to leave shop or repair tracks without hammering and blowing out the brake pipe is not treating the triple valve on the car or other cars in the train in a manner conducive to good operation. Applying triple valves to cars without first seeing that branch pipe strainers are inserted and in good condition, and failure to clean out dirt collectors at proper intervals causes numerous triple valve troubles.

A brake cylinder cannot be properly cleaned without removing the expander ring. An egg-shaped expander ring applied to a brake cylinder will soon wear packing leather through at the point where it bears heaviest against the cylinder wall. A car which leaves the repair track without having retaining valve and piping tested stands a good chance of being set out for air brake work if required to operate under grade conditions. Testing a retaining valve without ascertaining that both exhaust ports are open is inviting slid flat wheels and brake-burn wheels.

These illustrations of improper repairs, careless testing and poor maintenance convey some idea of the importance and value of a man in charge of maintenance who properly supervises the airbrake work. The fact that a railroad employs an air brake instructor or supervisor to have general charge of the air brake department, does not in any way relieve the man in charge of maintenance of the responsibility of knowing absolutely that the air brake work of the men under his supervision is of the proper character. In the case of the repair man in the car department, this duty falls upon the car foreman. The car foreman should obtain all assistance and instructions possible from the air brake instructor and encourage the men under him to do likewise.

Initial Inspection Test.—Cut in brakes on all cars not carded, and see that all air brake parts and piping, as well as foundation brake rigging, are in place, properly located and in good condition. Care should be taken to examine train pipe for rusted or worn places at the body bolster, for defects or corrosion at the angle cock nipple, and for condition of the retaining pipe at the end sill bend. Brake pipes should then be blown out. The brake system should then be charged to at least 70 lb. and inspected for leakage, to see that pipe clamps are in place and that nuts on bolts holding cylinders and reservoirs are tight. Leaky angle cocks and porous hose should be removed and replaced with hose and angle cocks that have been tested in the air brake room.

Retaining Valve and Brake Cylinder Test.—After making initial inspection, retaining valve handles should be turned up and brakes applied by making a service reduction of 20 lb., not more than five cars being tested at one time. See if all brakes have applied. Release, and one minute after the exhaust at the retaining valve begins brake shoes should still be firmly against the wheels so they cannot be moved with club or foot. Should there be practically no exhaust from the retaining valve when the handle is turned down it indicates a defective retaining valve, leaky retaining pipe or a leaky brake cylinder leather. It must be determined at each inspection that both exhaust ports of retaining valve are not clogged up by paint and dirt; that cock keys are not leaking; that handles are in good order,

and that the retaining valve is properly secured and stands perpendicular.

Brakes that do not apply with a service reduction; that apply quick action with a service reduction; that have leaky brake cylinder packing leathers; that have leaks at exhaust ports of triple valve, or those on system cars that have not been cleaned for eight months and foreign cars that have not been cleaned for twelve months, should have the triple valves removed and replaced with triple valves that have been cleaned and tested in accordance with M. C. B. standard practice, brake cylinders and dirt collectors cleaned, branch pipes blown out, branch pipe strainers cleaned and renewed if not in good condition, cylinders tested and stencilled according to M. C. B. standard practice.

After brakes have been cleaned and assembled, and piston travel adjusted, apply and release the brake several times to set the packing leather out against the wall of the cylinder; then make a 20-lb. brake pipe reduction and make a mark on the piston sleeve $\frac{1}{4}$ -in. from the non-pressure head and note at the expiration of three minutes if the mark is still visible. If not there is excessive brake cylinder leakage which must be located and repaired. Piston travel must be adjusted to between seven in. and 8 in. with a 20-lb. service reduction from an initial brake pipe pressure of at least 70 lb. Any brake shoes must be renewed before the piston travel is adjusted.

The Terminal Test.—No train should be permitted to leave a terminal without a terminal test. The brakes should be fully applied and thoroughly inspected while brakes are applied to note any irregularity that would be liable to produce train shocks and break-in-twos. Trains in transit over large systems of railroads should be tested at each division point and for such test we recommend an incoming brake test. The outgoing freight brake test should be merely a check against error. To then set out defective brakes for repairs is to disorganize despatching and switching, thus delaying cars ready to proceed and greatly augmenting expenses.

Incoming Freight Brake Terminal Test.—Enginemen and trainmen on arrival at the terminal will leave the brakes applied by a 20-lb. service reduction made from 70 lb. On its completion he will give one short whistle blast as advice to brakeman that he may cut off and to inspectors that inspection may begin. The brakeman will not close angle cocks until this signal is given.

On brakes being applied inspectors will rapidly examine for piston travel, brakes failing to apply, any that have leaked off and brake pipe leaks, indicating the defects with chalk. After completing the inspection, repair the defects that should be cared for in the yard. For other defects bad-order the cars for repair tracks unless impracticable, as may be with perishable or time freight. The air brake and the general inspection must not be combined.

Brake Pipe Leakage.—Excessive brake pipe leakage wastes air, takes away from the engineman the ability to control the amount of brake applications, contributes to brake sticking, causes overheating of the air compressor and even prevents the maintenance of standard brake pipe pressure. Hence, it must be avoided.

Brake pipe leakage is produced in numerous ways, but the most common causes for it are poorly clamped piping that will permit shifting in switch movements or shocks on the road, and allowing train and yard men to pull hose apart instead of separating them by hand, as this produces spread coupling jaws, destroys gaskets and creates porous hose.

Brake cylinder and auxiliary leakage are just as productive of damage to trains as is brake pipe leakage. If a triple valve permits the desired pressure to pass from the auxiliary reservoir to the brake cylinder and then due to a bad leather in the cylinder or defective gasket under the

pressure head the pressure is permitted to leak to the atmosphere, the effectiveness of that brake is lost. On the other hand, if we have a leaky auxiliary, either from a carelessly applied drain plug or a poorly fitting exhaust valve or a slide valve leaking, then after an application the auxiliary pressure leaks down until two or three lb. below the brake pipe pressure when the brake will release.

Other factors that assist in producing leakage are brake pipes applied out of proper height and distance from the face of the coupler; nipple ends broken off and new threads cut on old nipples, shortening the brake pipe, and angle cocks applied and not given the proper angle toward center of track.

Defective Triple Valves.—With the brake pipe and auxiliary fully charged trainmen, in separating the train, often close only the angle cock on the portion of train to be moved and then pull the brake hose apart, setting all the brakes in emergency on the standing portion of the train. Repeatedly applying brakes in emergency in this manner is frequently the cause of triple valves becoming defective on account of bent emergency piston stems. The only remedy is to remove and repair them.

Undesired quick action can be caused by permitting triple valves to become dirty and gummy to the extent that the piston sticks and requires a high differential to cause a movement. It can also be caused, especially with long trains, by a very light brake application or a very slow reduction where it would be avoided by braking according to proper methods.

How Train Shocks May Be Eliminated.—To prevent damaging shocks in long trains braking power must be as near uniform as possible on all cars, and that loaded and empty cars be so distributed that the greater part of each will not be at the head end or rear end of trains.

Long piston travel is preferable to short piston travel, because the cylinder pressure will be built up more slowly and consequently any movement of slack in the train will take place proportionately slower, with a reduction in the velocity difference between cars. While there will be a considerable difference in the cylinder pressure between a five-in. and seven-in. travel at the beginning of a brake application, the pressures will be nearly equal when the brake is fully applied. If the piston travel is short, say five in., it is possible to develop a high brake cylinder pressure (45 lb.) at the head end with a 10 lb. reduction before the beginning of brake application at the rear. This causes the slack to run in from the rear, sometimes with very damaging results if the speed is low. If the piston travel is long, say eight or nine in. standing travel, it is possible to make the same reduction and only produce 20 to 25 lb. cylinder pressure, less than one-half the pressure produced with the short piston travel. This reduces the rate of retardation set up on the head end of the train, and consequently the severity of any slack action due to a run-in of the slack.

Excessive Draw Bar Slack.—Another liberal contributor to train shocks and break-in-twos is excessive draw bar slack. The inspector should be instructed to watch this feature closely and make every effort to have cars with undue draw bar slack sent to the repair tracks in order that this may be corrected.

With no slack and good draft rigging, trains could not be broken in two. The same can be said with slack either all in or all out and held so. The damage arises from its sudden change. When slack runs in or out rapidly one part of the train gradually attains a lower speed than the other and the shock is the result of the draft rigging having to suddenly make the speed uniform on the instant the slack is all in or out. How heavy the shock will be depends mainly on the difference in speed that must instantly be made uniform and on the weight that must suddenly be altered in speed. Weight is important, but change in speed

is more so, as changing it suddenly three miles per hour will cause nine times the shock than will a similar quick change of one mile per hour.

The report was signed by E. Hartenstein, chairman; O. H. Bradbury and John Foster.

DISCUSSION

Among the points emphasized in the discussion of this report was the necessity for setting the brakes with a full application on incoming trains and the stretching test, in order that the condition of the brakes may be observed and the necessary repairs made during the time that the cars are in the terminal rather than after the outgoing trains have been made up and are ready to depart, and also for the purpose of inspecting worn knuckles and abnormal slack in the draft gear. The need for greater co-operation on the part of enginemen and trainmen in making these tests was brought out. It is often observed that the angle cocks between the locomotive and train are closed even before the train has been brought to a full stop. The practice of inspecting and cleaning brake cylinders and triple valves on team and house tracks which is now followed by some roads was endorsed. This insures that the brakes on the cars will be in good condition when they are made up into trains and that they will remain in the trains until they reach their destination. As a means of maintaining a reasonably constant piston travel with a minimum amount of labor, it was suggested that care be exercised at shops and repair tracks to see that brake shoes on a car are not of uniform thickness, but vary considerably between the limits of a new shoe and one ready to scrap. The ideal condition would be to have one new shoe, with a maximum wearing thickness of about 1 in., and the other shoes ranging in thickness in successive steps of $\frac{1}{8}$ -in. wear, the thinnest one being within $\frac{1}{8}$ in. of the scrapping limit. Under this ideal condition the shoes would be renewed successively one at a time at intervals of $\frac{1}{8}$ -in. wear, with a correspondingly small variation in the piston travel from the desired amount for which the brake rigging was adjusted.

The association adopted a motion recommending to the Master Car Builders' Association that Rule 6 be supplemented by a provision permitting all roads to clean brake cylinders and triple valves on foreign cars sent to the repair track for other defects, nine months after the previous cleaning.

OTHER BUSINESS

Reports were also submitted on the cross-compound air compressor; on the maintenance and operation of the feed valve, outlining the practice on the Canadian Northern, of concentrating the repairing of feed valves at a few points where competent labor may be maintained, and a specialized system of repairs for which a complete set of gages, special reamers, etc., has been developed; on M. C. B. freight brake stencilling, and on proposed changes in the recommended practice of the association. The stencilling report recommended that when either the triple valve or the brake cylinder must be cleaned, lubricated and tested, all other parts, including the retaining valve and the dirt collector, be cared for at the same time, and that any other repairs needed by the brake equipment be made then. It was suggested that this practice would save time and money, and would insure getting more service from cars than is obtained with the present practice of stencilling and maintaining each part separately at different times. This recommendation was adopted by the association to be presented to the Train Brake and Signal Committee of the M. C. B. Association.

The conservation of material and supplies was discussed at Wednesday's session, and the topic was assigned as the subject of a committee report to be prepared from the data presented by the members during the discussion and from

a more complete survey of the possibilities of conservation of air brake materials.

In addition to speeches by C. H. Weaver and D. R. MacBain, short addresses were given at the opening session by W. O. Thompson of the New York Central Lines; Martin Beman, director of Public Welfare of the city of Cleveland, and W. S. Stone of the Brotherhood of Locomotive Engineers. On Wednesday evening Walter V. Turner gave a lecture on freak inventions.

The treasurer reported the largest balance that the association has ever had in its treasury, and the executive committee voted to invest \$1,000 in War Saving Certificates. The secretary advised that the membership was now over 1,000. The officers elected were as follows: President F. J. Barry, New York, Ontario & Western; first vice-president, T. F. Lyons, New York Central; second vice-president, L. P. Streeter, Illinois Central; secretary, F. M. Nellis, Westinghouse Air Brake Company; treasurer, Otto Best, Nathan Manufacturing Company.

THE POOR LITTLE RICH BILL

BY GLADYS SCHUSTER

"Who are you?" our editor said yesterday, when a sick looking stranger appeared before him. "You look a bit familiar, although I'm sure I haven't seen you for some time."

"I'm A. Dollar Bill," the stranger weakly answered. "Oh—pleased to recognize you, Dollar Bill," cordially beamed our editor, holding out his hand. "You look a bit weak, old friend. What's the matter?"

"I'm not the same Bill I used to be," mournfully said the visitor. "I can only do about half the work I used to do before the war."

"Pretty tough," our editor reflected. "Have you been to see the doctor?"

"I went to see Dr. McAdoo," answered Bill, "and he told me that I'll never get my strength back until after the war. He said I ought to gain at least 25c. or 50c. in weight then. In the meantime, he said, I ought to have a rest, and my owner ought to lay me aside against the day when I will be worth more."

"That isn't a bad idea," observed our editor.

"I know," continued Bill, "that some of us Bills must go for food and clothing, no matter how weak we get. But there are lots of us that are going for luxuries and things that our owners don't really need. The fast times are killing us. I thought, if I called it to your attention you might say a word for us. Dr. McAdoo said a dose of publicity would help me. Now, of course, I don't want people to put me in a sock or behind the clock case until the Huns are defeated. My value will increase by investing me in absolute safety."

"How, for instance?" asked our editor, sympathetically.

"If you take four of us and add 17c. to us this month, making \$4.17 in all, you can buy a War Savings Stamp from Uncle Sam that will make me worth exactly \$5 cash to you on January 1, 1923, and worth even more when you consider how much more \$5 will buy than now. There is nothing imaginary or theoretical about it, either. We Dollar Bills are valuable only because we can buy things people want. I am more valuable when I can buy more of those things than when I can buy less of them. And Uncle Sam will gain while you gain. He will have the use of your money when he sorely needs it, and, believe me, he needs it. And I, Mr. Dollar Bill, will have the patriotic feeling that we have worked together for victory."

"Bill, you know what you are talking about!" exclaimed our editor. "Everybody ought to follow your advice."

2-10-2 TYPE LOCOMOTIVES FOR THE U. P.

Built for Service on Heavy Grade Division. Road Tests Show Unusually Low Weight per Horse Power

SEVERAL months ago the Union Pacific received from the Baldwin Locomotive Works 15 locomotives of the 2-10-2 type. These were part of an order of 27 locomotives, the others being placed in service on the Los Angeles and Salt Lake and the Utah railway. The locomotives were designed under the supervision of C. E. Fuller, superintendent motive power and machinery and A. H. Fetters, mechanical engineer, and were built particularly for use between Ogden, Utah, and Evanston, Wyo. This division has long heavy grades, the maximum grade being 1.20 per

cent for the heavy class of freight service in which these engines are used.

The boiler is of the straight-top type with a wide, deep firebox placed back of the drivers and over the rear truck. A combustion chamber four feet long extends forward into the boiler barrel, and the tubes have a length of 22 ft. The middle barrel ring has a slope on the bottom to provide a sufficiently deep water space under the combustion chamber. All seams in the firebox and combustion chamber are welded with the exception of that uniting the back sheet with the

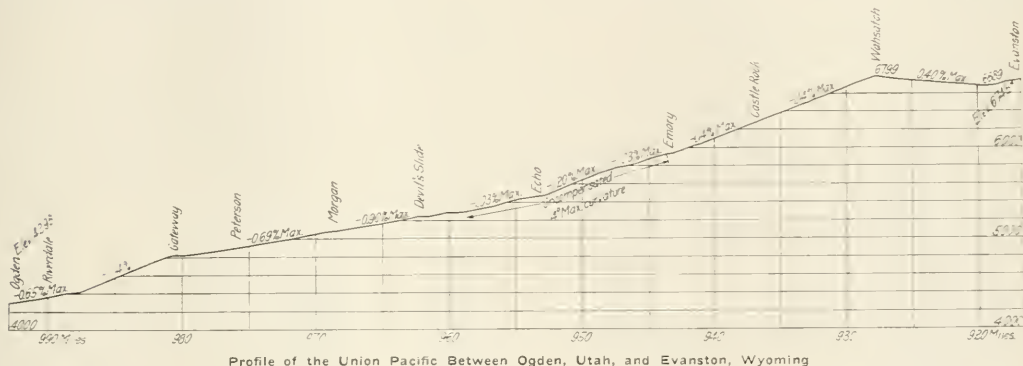

cent with a 4 degree curve, uncompensated, which is equivalent to a grade of 1.36 per cent on straight track. Reconstruction work is now in progress on this division and all grades are being reduced to 1.14 per cent, compensated for curvature. The principal object which was kept in mind in designing the 2-10-2 type locomotives was to make them capable of handling the same train over the reconstructed line between Ogden and Evanston, that the Mikado type

crown sheet and side sheets. The seam around the firedoor opening is also welded. Flexible staybolts are used in the breaking zone and in the six front rows of stays over the combustion chamber. At the point where the three upper rows of flexible stays on each side pass through the boiler barrel, bosses are welded to the sheet in order to provide a sufficient number of threads for the staybolt sleeves. Both the coal burning and oil burning locomotives are equipped

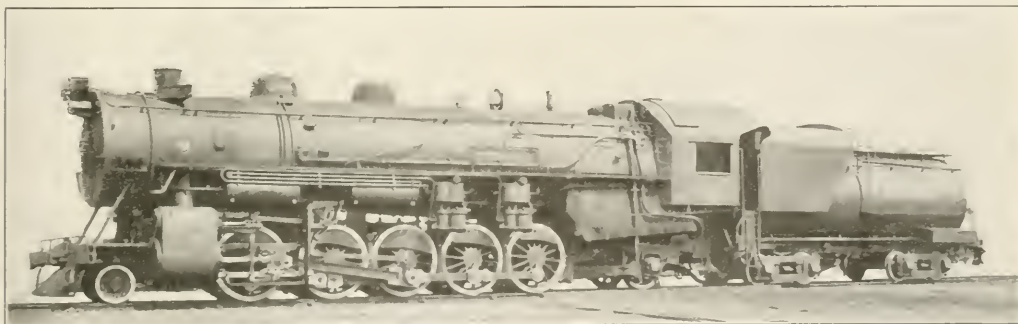

Heavy Freight Locomotive for the Union Pacific Which Develops 2,950 Horsepower

locomotives haul on the line east of Evanston, where for 400 miles the maximum grade is .81 per cent.

The 2-10-2 type locomotives have a rated tractive effort of 70,450 lb. with 285,500 lb. on the driving-wheels, the ratio of adhesion being 4.05. The total equivalent heating surface is 7,045 square feet or 1 square foot for each 10 lb. of tractive effort. This ratio indicates ample steaming capacity

with Security sectional arches and the coal burners are fired by Street type "C" stokers. The superheater consists of 45 elements and has a superheating surface of 1,262 square ft.

The piston valves are 15 in. in diameter and are driven by Walschaert valve gear which is controlled by a Ragonnet power reverse gear having both air and steam connection. The piston heads—a drawing of which is shown below, are

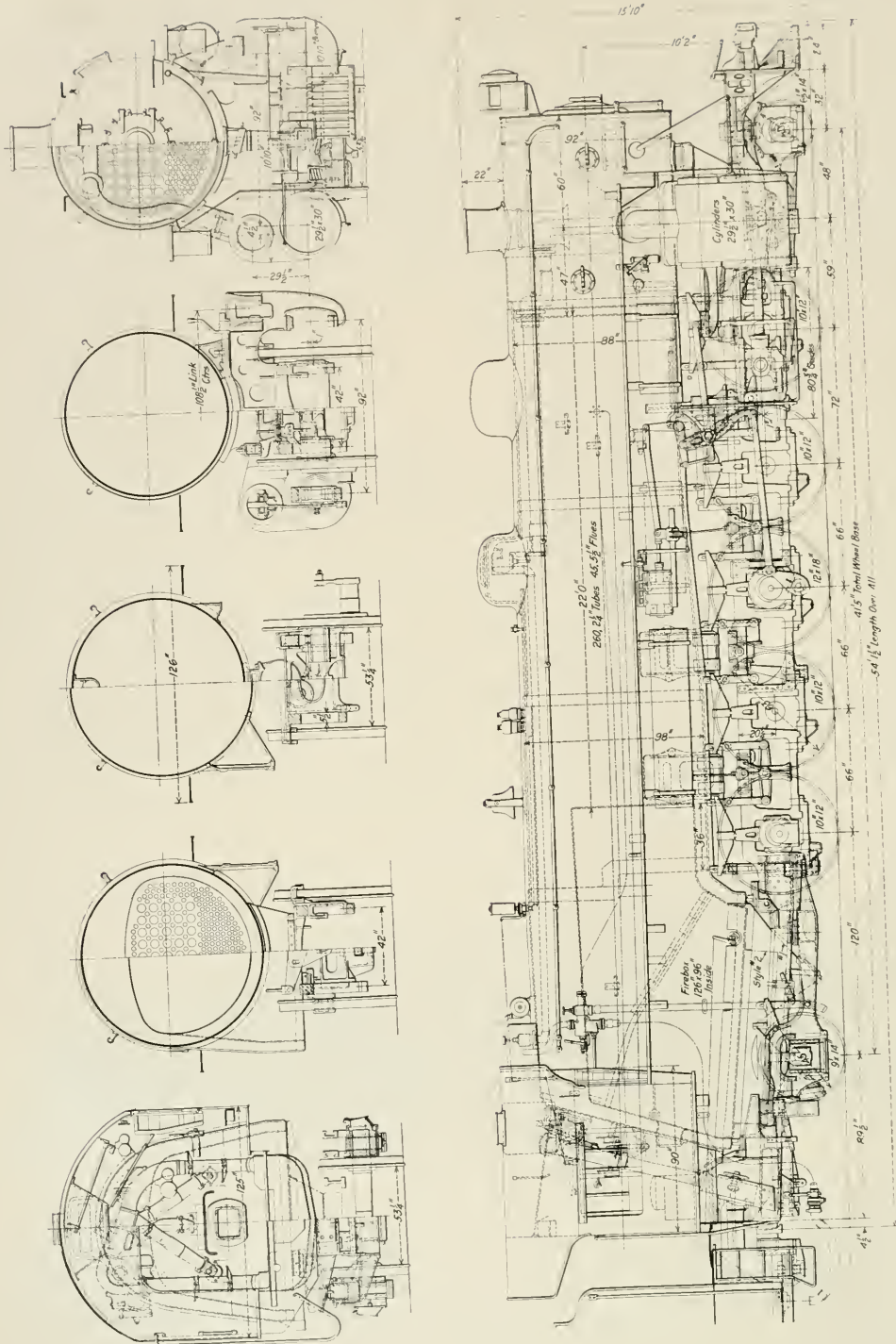

Elevation and Cross Sections of Union Pacific 2-10-2 Type Locomotive.

steel castings of dished section, seven inches wide, with phosphor bronze bearing rings and gun iron packing rings. The phosphor bronze rim is cast on the piston before the grooves for the packing rings are turned. Inspection of these pistons after six months' service showed that they had worn less than 1/4 in. The piston rods are of open-hearth steel, heat-

bilt type, with equalized trucks and one piece cast steel frame.

RESULTS OF ROAD TESTS

The Union Pacific has conducted road tests of locomotives of many different types and classes. From the results of

	0 to 250	300	400	500	600	700	800	900	1,000	1,100	1,200	1,300	1,400	1,500
Piston speed ft. per min.	0 to 250	300	400	500	600	700	800	900	1,000	1,100	1,200	1,300	1,400	1,500
Ratio of M. E. P. to (saturated)	.85	.785	.700	.615	.540	.480	.420	.360	.305	.260	.220	.185	.155	.125
Boiler pressure (superheated)	.85	.785	.710	.615	.542	.495	.445	.390	.335	.295	.255	.220	.190	.160

treated and hollow-bored. The same material is used for the crank pins and driving and trailing axles which are also hollow-bored. The reciprocating parts are unusually light, the total weight being only 1,925 lb. The dynamic augment of the wheel load at diameter speed does not exceed 48.6 per cent of the weight on the wheel. Long driving boxes are applied to the main axle and lateral motion boxes to the front axle. The latter are used in connection with the Economy constant resistance leading truck.

The frames are annealed vanadium steel castings 5 1/2 in wide and spaced 42 in. between centers. They are braced transversely between adjacent driving wheels and also at the third, fourth and fifth pairs of driving pedestals. The driving box wedges are self-adjusting. The Commonwealth rear frame cradle is applied in combination with the Delta trailing

these tests a set of speed factors has been worked out to show the ratio of mean effective pressure to boiler pressure at various piston speeds. These ratios for various types of locomotives are given in Table I.

A curve showing the tractive effort of the 2-10-2 type

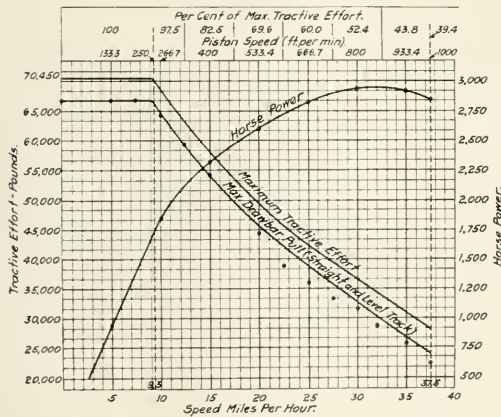

Test Results Secured with 2-10-2 Type Locomotive on the Union Pacific

truck, which serves the triple purpose of a frame, radius bar and equalizer. The trailing truck is equalized with the two rear pairs of drivers, the equalization being through a central, vertical, heart-shaped link which is suspended from a transverse beam hung from the rear driving springs. This link acts not only as the equalizer connection but also as the rear truck radius bar pin. It is circular in section at its lower end, and is guided in the frame cradle casting. The bearing between the equalizer frame of the truck and the locomotive frame is made with a spherical surface to provide sufficient flexibility.

The driving brake system is divided between the third and fourth pairs of wheels. The rear cylinders are placed in a horizontal position back of the main pair of wheels, while the front cylinders are placed vertically and are bolted to the cylinder saddle casting. The arrangement is such that all shoes bear on the backs of their respective wheels. The tender is carried on forged steel wheels, and is of the Vander-

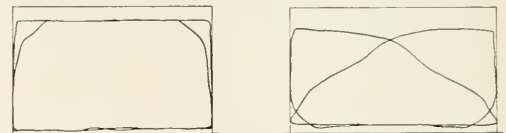

Steam pressure 200 lb.
 Mean effective pres. 168.07 lb.
 Throttle opening, ... 100 per cent
 Reverse lever notch, ... Corner
 Miles per hour, Starting
 Tractive effort 69,665 lb.

Steam pressure 198 lb.
 Mean effective pres. 113.4 lb.
 Throttle opening, ... 100 per cent
 Reverse lever notch, 6
 Miles per hour, 20
 Tractive effort 47,000 lb.

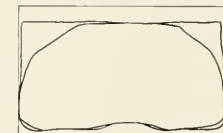

Steam pressure 200 lb.
 Mean effective pressure, .160 lb.
 Throttle opening, ... 100 per cent
 Reverse lever notch, 12
 Miles per hour, 5
 Tractive effort 66,320 lb.

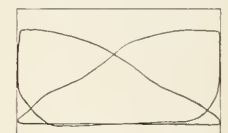

Steam pressure 197 lb.
 Mean effective pres. 93.05 lb.
 Throttle opening, ... 100 per cent
 Reverse lever notch, 12
 Miles per hour, 25
 Tractive effort 38,570 lb.



Steam pressure 200 lb.
 Mean effective pressure, .154.2 lb.
 Throttle opening, .87.5 per cent
 Reverse lever notch, 12
 Miles per hour, 10
 Tractive effort 63,915 lb.

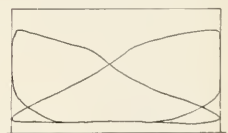

Steam pressure 195 lb.
 Mean effective pres. 84.32 lb.
 Throttle opening, ... 100 per cent
 Reverse lever notch, 5
 Miles per hour, 30
 Tractive effort 34,950 lb.

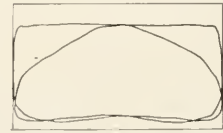

Steam pressure 196 lb.
 Mean effective pres. 133.6 lb.
 Throttle opening, ... 100 per cent
 Reverse lever notch, 10
 Miles per hour, 15
 Tractive effort 55,380 lb.

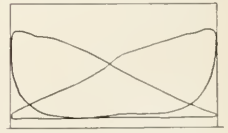

Steam pressure 195 lb.
 Mean effective pres. 72.4 lb.
 Throttle opening, ... 100 per cent
 Reverse lever notch, 4
 Miles per hour, 35
 Tractive effort 30,000 lb.

Fig. 2—Representative Indicator Cards, Union Pacific 2-10-2 Type Locomotive

locomotive as calculated from these speed factors will be found in Fig. 1. The maximum drawbar pull on straight and level track is shown by another curve on the same chart.

This is obtained from the curve of maximum tractive effort by subtracting 22.2 lb. per ton weight on drivers for machine friction, and 4.5 lb. per ton weight on the leading and trailing trucks and tender trucks, this being an average value for train resistance at low and medium speeds. The points

from Rock Springs, Wyo. The average amount burned per trip was 48,627 lb., which is at the rate of 9,725 lb. per hour or 115.7 lb. per square foot of grate area per hour. The average coal consumption per 1,000 gross ton miles was 358.4 lb. The average evaporation per trip was 27,283

TABLE 11. DETAILS OF ENGINE PERFORMANCE

Location	Speed m.p.h.	Reverse lever (notch)	Throttle (opening)	Steam pressure	Maximum tractive effort of engine	Grade				Dynamometer plus engine grade resistance	Maximum calculated
						Per cent	F. & T. resistance	Shown by dynamometer	Drawbar pulls (lb.)		
Castle Rock	Start	Cor.	Full	200	70,450	1.792	1.14	6,085	60,500	66,585	66,820
Leaving Castle Rock	5	12	Full	200	70,450	1,826	1.14	6,085	60,500	66,585	66,820
Leaving Castle Rock	7 1/2	12	Full	200	70,450	1,826	1.14	6,085	60,500	66,585	66,820
Mile Post 933	10	12	Full	300	68,600	1,760	1.14	6,085	57,500	63,885	64,000
Leaving Castle Rock	12	12	Full	198	63,450	1,760	1.14	6,085	53,500	59,585	59,720
Passing Uintah	15	10	Full	196	58,120	1,826	1.14	6,085	47,500	53,585	54,400
Mile Post 987	20	6	Full	198	49,000	1,760	1.14	6,085	38,000	44,085	45,300
Mile Post 996	22 1/2	6	3/4	300	45,700	1,760	0.65	3,470	35,000	38,470	41,900
Mile Post 987	25	4	Full	200	42,270	1,760	0.68	3,660	32,500	36,130	38,490
Mile Post 988	27 1/2	7	Full	200	39,450	1,780	0.68	3,660	29,500	33,125	35,745
Mile Post 969	30	5	Full	195	36,600	1,746	0.65	3,470	28,000	31,470	32,600
Mile Post 973	32	5	3/4	195	34,280	1,746	0.55	2,600	26,000	28,600	30,690
Mile Post 962	35	4	Full	195	30,850	1,746	0.40	2,135	20,000	25,635	26,900
Mile Post 959	37 1/2	3	Full	200	27,760	1,746	0.40	2,135	20,000	22,135	24,265

*Weight of eng. and ten., 267 tons.

plotted along the drawbar pull curve are values of the drawbar pull recorded by the dynamometer car, corrected for the grade resistance of the locomotive and tender. It is interesting to note how closely the calculated and actual drawbar pulls correspond. At the higher speeds the values found in the test fall below the curve due to the fact that the locomotive was not worked to its full capacity at these speeds. Some of the details of the engine performance are given in Table II.

The horse power curve is also shown in Fig. 1. A maxi-

gallons, the equivalent evaporation per pound of coal being 5.69 lb.

The principal dimensions, weights and ratios follow:

General Data	
Gage	4 ft. 8 1/2 in.
Service	Freight
Fuel	Coal or oil
Tractive effort	70,450 lb.
Equivalent heating surface*	357,600 sq. ft.
Weight on drivers	285,500 lb.
Weight on leading truck	23,600 lb.
Weight on trailing truck	48,500 lb.
Weight of engine and tender in working order	554,200 lb.
Wheel base, driving	12 ft. 6 in.
Wheel base, total	41 ft. 5 in.
Wheel base, engine and tender	77 ft. 6 in.

Ratios	
Weight on drivers + tractive effort	4.05
Total weight + tractive effort	5.08
Tractive effort x diam. drivers = equivalent heating surface*	.630
Equivalent heating surface* = grate area	.839
Firebox heating surface = equivalent heating surface* per cent.	5.37
Weight on drivers + equivalent heating surface	40.5
Total weight + equivalent heating surface*	50.8
Volume both cylinders	23.73 cu. ft.
Equivalent heating surface* = vol. cylinders	206.9
Grate area = vol. cylinders	3.54

Cylinders	
Kind	Simple
Diameter and stroke	29 1/2 in. by 30 in.

Valves	
Kind	Piston
Diameter	15 in.
Greatest travel	6 1/2 in.
Outside lap	1 1/2 in.
Inside clearance	1/8 in.
Lead in full gear	1/8 in.

Wheels	
Driving, diameter over tires	63 in.
Driving, thickness of tires	3 1/2 in.
Driving journals, diam. and length	12 in. by 13 in.
Driving journals, others, diam. and length	10 in. by 12 in.
Engine truck wheels, diameter	30 in.
Engine truck, journals	6 1/2 in. by 14 in.
Trailing truck wheels, diameter	23 in.
Trailing truck, journals	9 in. by 14 in.

Boiler	
Style	Straight top
Working pressure	200 lb. per sq. in.
Outside diameter of first ring	88 in.
Firebox, length and width	126 in. by 96 in.
Firebox plates, thickness, back and crown	1 1/2 in. by 1 1/2 in.
Firebox, water space	Front, 6 in.; sides and back, 5 in.
Flues, number and outside diameter	45-5 1/2 in.
Flues, number and outside diameter	260-2 1/2 in.
Tubes and flues, length	23 ft. by 13 in.
Heating surface, tubes and flues	4,774 sq. ft.
Heating surface, firebox, including arch tubes	3,78 sq. ft.
Heating surface, total	5,152 sq. ft.
Superheater heating surface	1,260 sq. ft.
Equivalent heating surface*	7,945 sq. ft.
Grate area	84 sq. ft.

Tender	
Tank	Cylindrical
Frame	Cast steel
Weight	194,600
Wheels, diameter	33 in.
Journals, diameter and length	6 in. by 11 in.
Water capacity	10,600 gal.
Coal capacity	17 tons

*Equivalent heating surface = total evaporative heating surface + 1.5 times the superheating surface.

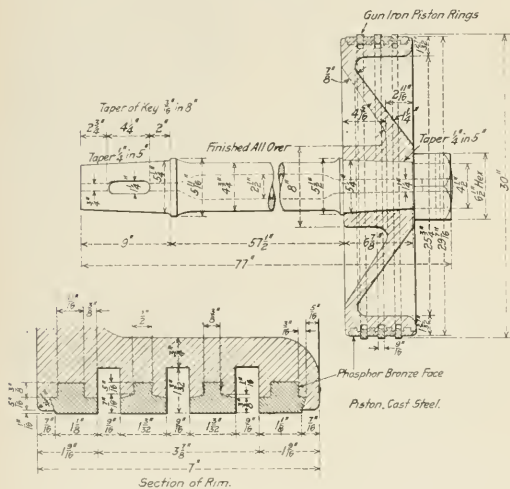

Piston and Rod for the U. P. 2-10-2 Type Locomotives

imum of 2,940 indicated horsepower was developed at a speed of 30 miles an hour. At higher speeds the horsepower decreased somewhat. When working at its greatest capacity this locomotive developed one horsepower for each 121.6 lb. total weight, which is a very creditable performance. Representative indicator cards taken at various speeds are shown in Fig. 2.

The average tonnage handled on the test trips between Ogden and Evanston was 1,800 gross tons excluding the engine and tender. The average speed while running was 15 miles per hour. The coal used was 2 1/4 in. screenings

A SYSTEM OF LABOR COMPENSATION

A Combination of the Taylor, Piecework and Prusso-Hessian Methods Developed in Russian Railway Shop

BY M. K. SMOGORJEVSKY, M. E. *
Formerly Assistant Superintendent, Dvinsk Railway Shops, Russia

THE marked increase in the costs of production in Russia in recent years has been mainly due to the constantly increasing cost of labor. Highly efficient, new, powerful machinery, labor-saving devices and automatic machinery counteract this increase to a certain extent, but cannot be solely relied upon to keep the cost of production down unless combined with the increased efficiency of labor. Modern equipment is very costly and proves to be but an additional burden if not worked to its full capacity. Therefore, in the vital problem common to all modern industries of how to keep the cost of production down, the question of increasing the efficiency of labor is of the greatest importance, and in many instances it is even more important than modernizing and improving the equipment. This is particularly true in regard to railway shops.

Compulsory methods of increasing the efficiency of workmen have been discarded, as they do not produce results. The prospect of material benefits, otherwise better earnings, is the only motive power that will make an average man work with more zeal. With this end in view, namely, to give the workman an incentive to increase his efficiency, several systems of wage payments have been devised and tried out, but none of them could be considered perfect so far, as none of them equally well satisfies employer and the employee. Before submitting the following plan proposed by the author, a brief, critical review will be made of the most typical systems of wage payments, so as to bring out

*Mr. Smogorjevsky has traveled abroad investigating the actual results of application of various wage payment systems wherever possible. He invented an instrument for drawing the Basual Curve, thus giving the practical application to a solution of three-section of acute angles graphically. Since his connection with the railroad shop at Dvinsk he has studied the systems of wage payments, their application and results, attitude of workmen to these different systems, their psychology and desires. Early in 1913 he began the investigations for the purposes of determining the periods of time consumed per operations and gradually readjusted piece prices and wage rates. At first the attempt to investigate and record results and readjust the piece prices was met with objections, workmen naturally supposing that it is no more than a usual attempt to reduce their earnings. To offset this he resorted to a diplomatic course, placing posters explaining briefly the system and its workings, and held several meetings for the purposes. The result was more than had been expected, the workmen became rather enthusiastic and afterwards cooperated in all possible ways. He began the application of a system in August, 1918, and a year later Dvinsk was evacuated. Of course, in such a short time it is hard to expect to have definite data so as to finally approve or disapprove the system, yet so far as could be judged the results were excellent. In changing to this new system one of the most difficult points was to determine the rates for those that had been working in a place already for a considerable time, it had to be done considering their last earnings, their abilities and age. This article was translated by James Gray, formerly of the Russian Mission of Ways and Communications in America, from an address by Mr. Smogorjevsky in 1914 at the convention of railroad engineers and cost accountants. The address of Mr. Smogorjevsky was approved, and he was authorized to try out the system unofficially. The war and the evacuation of the Dvinsk shops stopped the further experimenting for the time being.

more clearly the necessary requirements of a perfect system.

STRAIGHT PIECEWORK SYSTEM

A straight piecework system is the oldest and most extensively used up to the present time, and is in operation in Russian railway shops. According to this system, the actual earnings of the men are determined by the piece price and the output, but there are no rules or regulations provided for guidance in determining the piece prices. This matter is left entirely to the judgment of the head of the department, and very often no particular investigation is made of the actual time required for the performance of the work. Independent of the actual earnings, there is a day wage set for each and every man, which is a guarantee of the minimum earnings. This day wage is usually much lower than the actual earnings, and is increased from time to time. The amount of the increase and the period of time after which a man is entitled to such increase is also left to the judgment of the man in charge. Then periodically the actual earnings are summed up for the period of time and the ratio of this total to the sum of the daily wages for the same period serves as a kind of criterion to verify the piece prices.

The weak point of this system is the absence of rules for a determination of the piece prices. Left entirely to the discretion of the man in charge, piece prices bear a highly individual character. Some work happens to be undervalued, so as to leave a very low margin of possible surplus earnings, and some is overvalued. The result is that in the case of undervaluation there is always dissatisfaction on the part of the employees, and in the case of overvaluation, the workmen usually reduce the output purposely, so as not to give any reasons for a readjustment of the piece prices. Each attempt to readjust the prices is met with objections. Consequently this system, while it increases the efficiency in many cases, could not ultimately guarantee the reduction of the cost of production, and, furthermore, it does not guarantee a just compensation to the workmen. Very often a mechanic of rather limited ability makes big pay simply because he was lucky enough to get an overvalued piece of work, while a good man may happen to make just the minimum wage because the job he is working on has been undervalued.

PRUSSO-HESSIAN SYSTEM

This system introduces a new element into consideration, which is the piece time, or the time taken to perform the task

by an average mechanic. The day wage is increased periodically and systematically, according to the length of service and the piece price is determined by the day wage and the piece time. This system gives a more stable basis for determining piece prices, but they are standardized, which from a technical point of view is not advisable because the methods of production change constantly and therefore the piece time of today may be obsolete tomorrow. The method of determining the piece time, although a great improvement as compared with that used in the straight piece work system, can not be considered perfect, as it depends greatly on circumstances. Usually, when given a new piece of work, the mechanic understands that the time required to do it will be considered when determining the piece time and he will purposely slow down so as to get a good price.

The increase of wages periodically and systematically is a good point as it tends to keep the man in one place, but as it is done considering simply the length of service, and no other individual qualities, it fails. The increases do not depend on a man's ability or his zeal, and it doesn't take a good mechanic long to find out that no matter how hard he may try under this system he will never receive very much more than his neighbor of limited abilities. Consequently, he either looks for a better chance in some other place, where he can get a fairer compensation for his skill and extra efforts, or he becomes indifferent to his work.

THE DIFFERENTIAL TAYLOR SYSTEM

This system determines the piece time by an investigation of the periods of time necessary for the performance of each operation. It sets a high standard for the day's work; it pays a high premium for those who are able to live up to that standard and considerably reduces the pay of those who fail, and after repeated failures, these men are usually discharged. The piece time is made up of elementary or unit times necessary for each and every operation, and necessarily it is more correct than when determined in any other way.

The Taylor system artificially sorts out first-class mechanics from the rest who are simply thrown out. The effect on the industry is most beneficial and from the employer's point of view possibly this system is the best, but naturally, it is greatly opposed by employees, and, being thoroughly acquainted with the psychology of the Russian workman, I would say that it could not be applied to a very great extent in Russia. The labor trouble caused by the adoption of this system will more than offset its benefits, and from a human point of view it cannot be recommended. Besides these three systems there are many others, but in most cases they are variations of those just described. Among them is the gang system, where the work is distributed among different gangs and the total gang earnings are divided among its members in proportion to their wage rates. The bonus system also may be mentioned.

In view of the above mentioned limitations it will be evident that the theoretically perfect wage system on the one hand must positively guarantee to the employer the increased efficiency of labor and consequent reduction of costs, and on the other hand, it must guarantee a rational and just compensation to the workmen according to their ability and efforts. It must provide also for the increase of wages with years of service. This will prevent the constant turnover of labor, which is one of the greatest evils of the present-day labor conditions.

The system of wage payment about to be described does not pretend to be an original one but essentially it includes all the good points of the Taylor and the Prusso-Hessian systems with slight variations. Moreover it is a great improvement over those systems and overcomes most of the difficulties which are the natural results of their application.

The Taylor method of determining the piece time as made up of periods of time consumed per operation, is the best.

Some of these periods or unit times, as for instance the time necessary to take a cut, depend exclusively on the properties of the machinery, materials used for manufacturing purposes, grades of tool steel, etc. Some of them, like the time consumed in setting up work, regrinding the cutter, will depend on the skill and experience of the workman, and some will depend on supplementary equipment of the shop, such as transportation facilities, lifting facilities, etc. Consequently, the periods of time per operation referred to can be determined by a fore-study and observation of the properties of the machinery and materials. To determine the periods of time per operation is the preliminary and most important part of the work, and if applied in Russian railway shops, where it has never been tried up to the present, it will take probably about two or three years, but when records are completed the matter of determining the piece time, otherwise, summing up the differential times, will be an easy task. Besides this, when any improvement in equipment is made, which will necessitate the readjustment of the piece time, this can be done very easily by determining the period of time per operation on a new machine and substituting it instead of the period of time taken on the old machine.

Very often the same piece of work can be done on various machines and on account of the difference in these machines the piece time will change and therefore the piece time should be determined not only for each and every piece of work, but for each and every machine. This will give valuable information or data to the manufacturer as he will be able to see from these figures the relative advantages of different machines for a particular job. It will also train the workman to understand that the piece time is not something abstract and standard, but is closely related to the properties of the machinery and tools used for the work, and then if any adjustment of piece time becomes necessary on account of improvement of the equipment this will seem but natural and will cause no objections.

The piece time determined by the above investigation is the minimum time, in which it is possible to turn out the work. Its attainment is possible only under ideal conditions and under normal conditions the same piece of work will take a little more time. This increase in time will have to be determined for each shop separately by recording the time consumed per operation by some of the workmen and finding an average. This should be compared with the minimum time, bearing in mind that a margin must be left for an average workman to earn at least a small surplus above the wage rates so as to coax him to intensify his efforts. Considering this increase in piece time as normal, we come to a normal piece time which is the basis of the proposed system.

THE SMOGORJEVSKY SYSTEM

The most convenient wage rate as applied to this system will be the rate per hour. The rate per hour multiplied by the normal piece time will determine the cost per piece. The piece time multiplied by the number of pieces of work turned out will determine the earned hours, so to speak, and the rate per hour multiplied by this number will give the actual earnings in dollars and cents.

The rates per hour, of course, will be greatly influenced by the perpetual law of supply and demand, and must be set so as to allow an average workman to earn a standard wage, when working the regular number of hours per day. In regard to Russian railway shops the rates will have to be increased as at present they are unreasonably low.

As each workman, according to his individual qualities, can perform the work in more or less than normal time, his daily earnings will change accordingly and the ratio of his earnings for any period of time to the total of his wages for the same period of time will determine his efficiency. With the increased efficiency of labor, the cost of production will go down. The efficient mechanic will be more useful

to the industry and therefore he will expect and ought to get more than his neighbor of more limited ability. Under this system of wage rates he will be able to go as high as his skill and ambition will permit.

But a man's wage rate should depend also on his length of service because with years he gets more experience and more knowledge of his line of trade. In short, he is more valuable than a new man who just starts in. The man who has been in the shop for several years knows all the ins and outs, and there is no time lost in breaking him in, so the raise in wages with years is no more than just. The Prusso-Hessian system took into consideration the length of service but failed because other qualities were neglected. Men differ greatly in their personal characteristics and abilities and those that are more skilled, more experienced and more attentive to their work must be distinguished.

In giving raises then, it is necessary to take into consideration three co-efficients. First, the *co-efficient of efficiency*, which is the ratio of the total earnings for any period of time to the total wages for the same period. Second, the *co-efficient of quality*, which is the ratio of the difference of the earnings and costs of the rejected work to the total earnings. For instance, if the yearly earnings of a mechanic are \$1,000 and the cost of rejected work is \$30, then the co-efficient of quality will be: $(\$1,000 - \$30) : \$1,000 = \$970 : \$1,000 = .97$. Third, the *co-efficient of attendance*, which is the ratio of the number of days the workman has been in the shop to the total of working days for the same period. The amount of raise should be standardized, but the periods of time, after which a man is entitled to a raise will differ according to the product of his co-efficients, and strictly in accordance with a wage scale, which will look something like the following:

Classes	Co-efficients			$\alpha\beta\mu$	Periods of time after which the workmen are entitled to a raise
	Efficiency α	Quality β	Attendance μ		
I	1.3-1.4	.99	.98	1.3	1.4 years
II	1.2-1.299	.98	.96	1.16	1.6 years
III	1.1-1.199	.97	.94	1.03	1.8 years
IV	1.0-1.099	.96	.91	.91	2.0 years
V	Less than 1	Less than .91	Wage is not increased.

As seen from the above table, all employees are grouped in five classes, according to their individual qualities. A man of each group will get an increase after a certain period of time as indicated. The men that will come into the fifth group, whose product of co-efficients is below one do not get the increase, of course, and eventually are discharged if after a fair trial on some other work they fail to make a better showing. It may be stated that the above table is given simply for the purpose of illustrating the system, and does not represent actual figures taken in practice. In reality, according to circumstances the number of classes could be increased or decreased, and also the periods of time, after which a man is entitled to a higher wage, may be determined by the actual figures for the three co-efficients.

Periodical and systematic increases in wages depending on these three co-efficients is the basic principle of the system which for the sake of clearness may be summed up as follows:

First.—By investigation, observation and a thorough study the periods of time necessary for the performance of each and every operation for each and every machine are determined. These elementary times are summed up, thus determining the minimum piece time or *base time*.

Second.—The minimum piece time is increased according to experimental data, thus determining the *normal piece time*.

Third.—A rate per hour is set for every class of mechanic, and this rate is increased systematically according to scale in reverse proportion to the product of their co-efficients of efficiency, quality and attendance, the co-efficients being the abstract expression of individual qualities.

Fourth.—Output and normal piece time determine the number of hours the workman gets paid for; the rate per hour and this number of hours determine the actual earnings, and the rate multiplied by the normal piece time will give the cost per piece.

The system of wage payments being outlined, it remains to prove that it will come up to the requirements of a better system; i. e., to prove whether it guarantees the employer the increased efficiency of labor and reduction of costs, and to the workmen a just compensation according to their skill, experience, extra efforts, and length of service. The answers to these questions are practically self-evident, but the following discussion will perhaps convince those who are skeptical.

The workman increases his efficiency when he has a reasonable outside impulse to do so. This impulse, as mentioned before, could be nothing else but the prospect of better earnings. As explained, this system gives every man a chance to perform his work in a shorter time and thus increase his earnings. On the other hand, the piece price is determined by the rate per hour and piece time. If a man gets more per hour he gets a better piece price. Everyone has an equal chance to increase his rate per hour by increasing his co-efficients of efficiency, quality and attendance. The higher these co-efficients are, the sooner he will get the increase. These two reasons prompt the men to intensify their efforts to turn out more and better work, and the effects on the industry will no doubt be the increased efficiency of labor and reduction of costs. The actual earnings of the workmen as affected by these two factors, i. e., increase of efficiency and periodical increase of wage rates, are illustrated graphically in Fig. 1. The scientific method of determining the piece times also will do much for the reduction of costs, at least in those industries where it has not been applied up to the present, and where many operations just now happen to be considerably over-valued.

In regard to the second requirement of the system, that a just compensation be guaranteed for everyone, there are four factors to consider; output, length of service, or age of workmen, and skill or experience. Therefore, the system proposed is believed to be more just than any other, as it takes them all into consideration. Furthermore, the individual qualities are valued objectively, referring to actual records of performance, and all the increases in wages or adjustments of piece time are done systematically according to wage payment scales. The men are given a fair and equal chance to in-

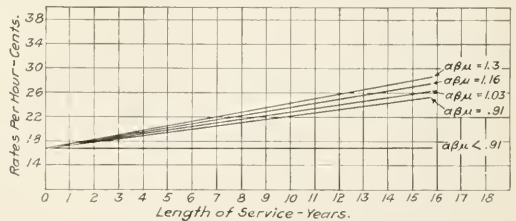

Fig. 1—Graphical Representation of Wage Rate Increases

crease their earnings. This system also eliminates all petty squabbles among the men themselves, and between the men and the administration.

The increase of wages of the workman with the length of time of his being in employ is one of the provisions of the system, so it satisfies the employe in this respect, and on the other hand it prevents labor turnover and saves the employer the losses resulting from the constant exchange of men, such as time lost in breaking in a new man, extra office expense, advertisements, etc., consequently also contributing to the lowering of the costs of production. In short, the workmen will be satisfied, the increase of the efficiency of labor will

be assured and the result will be a reduction in the cost of production provided the periodical increase in wages does not offset the benefits of other factors that make up the system.

REDUCTION IN COST OF PRODUCTION

This is a point concerning which questions may be raised and the following will prove that it will not happen.

Suppose that the total output of a certain shop and the total number of men employed remain constant. Under such circumstances any fluctuation of average wage rates will cause a change in costs per piece. An increase of wage rates will cause an increase of costs per piece and vice versa. As the wage rates are raised from time to time and the costs per piece are determined by the rate per hour and time consumed per piece, it is obvious that the cost of production of the same piece of work will vary depending on the rate per hour of the man who is working on it, yet the total costs can be maintained on the same level or lowered if it is possible to keep the average rate constant or lower it.

To prove that under this system the increase of wage rates of some of the men will not increase the average rate, the relation between the factors that influence this average rate will have to be expressed in algebraic formulae.

Let:

- p_0 = Average rate per hour of a workman for all the time of his being employed.
- p = Average rate per hour of all the men in the shop at any time.
- T = Average length of employment of a workman.
- t = Average interval between two consecutive raises in wages.

- $n = \frac{T-t}{t}$ = Average number of raises in wages a workman gets during all the time of his being in employ.
- m = Amount of raise in cents.
- a = Co-efficient, which is ratio of the starting wage to an average wage.

- $p_1 = ap_0$ = Starting rate per hour.
- β = Co-efficient, which is the ratio of maximum wage to average wage.

- $p_e = \beta p_0 = ap_0 + mn$ = Maximum rate per hour.
- y = Number of men changed during one year, per 100 men.
- $x = yt$ = Number of men changed between two consecutive raises, per 100 men.

The average wage could be determined by adding the minimum and maximum wages and dividing by two which gives the following equation:

$$p_0 = \frac{p_1 + p_2}{2} = \frac{ap_0 + \beta p_0}{2} = \frac{2ap_0 + mn}{2};$$

or substituting $\frac{T-t}{t}$ instead of n :

$$p_0 = \frac{m(T-t)}{2t(1-a)} \tag{1}$$

Next, to express in a formula the relation between p and y supposing that the turnover of labor is due solely to natural causes, such as death, loss of ability, etc., and that the average rate should remain constant. Under this supposition we may say that most of the men falling out will be the ones that get the highest rate, $p_2 = \beta p_0$, and all that start are getting $p_1 = ap_0$.

Total of hour rates per 100 men at the average rate = p_0 will be

$$100p \tag{a}$$

After a completion of an exchange of x workmen between two consecutive raises, the same total of rates per 100 men can be expressed thus:

$$(100-x)(p^2 + m) + apx \tag{b}$$

where

$$p^2 = \frac{100p - \beta px}{100 - x} = \frac{(100 - \beta x)p}{100 - x} \tag{c}$$

As the total of rates per hour per any number of men ought to be equal at any time

$$100p = (100-x)(p^2 + m) + apx$$

or substituting instead of p^2 its meaning from (c) and solv-

ing the equation considering the p to be unknown, the equation becomes:

$$P = \frac{(100-x+m)}{2x(1-a)} \tag{d}$$

or substituting yt instead of x :

$$P = \frac{100-yt+m}{2yt(1-a)} \tag{2}$$

As the average rate of any workman for all the time of his being in employ should not differ materially from an average rate per hour of all the workmen at any time, equations (1) and (2) give a new equation:

$$\frac{m(T-t)}{2t(1-a)} = \frac{m(100-yt)}{2yt(1-a)} \tag{3}$$

Reducing this equation to its simplest form and solving it considering the y to be unknown:

$$y = \frac{100}{T} \tag{4}$$

If $T = 40$ years, then $y = 2.5$ men per 100 men or 2.5 per cent.

Equation (4), which is the result of the reduction of equation (3) to its simplest form, shows that the constancy of average rate per hour depends exclusively on the average of how long the workman remains in employ. This equation is a mathematical expression of a common politico-economical law determining the average per cent of labor turnover due to natural causes. The very same result can be obtained also in another way, as follows:

If the average length of time of being in employ = T years, then in 100 years the staff of employees will exchange completely $\frac{100}{T}$ times, in one year $\frac{1}{T}$ times and the exchange

per 100 men will be $\frac{100}{T} = y$.

Substituting this meaning for y and reducing to its simplest form, equation (2) becomes

$$P = \frac{m(T-t)}{2t(1-a)}$$

or in other words the same expression as that for p_0 in equation (1). This proves that the equality of average rate per hour of all the men at any time and average rate per hour of any workman for all the time of his being in employ are possible

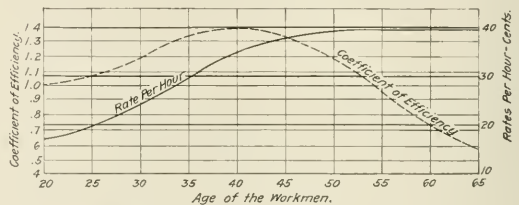

Fig. 2—A Comparison of Wages and Efficiency with Increasing Years

only on condition that the turnover of labor will be due but to natural causes. In reality the men leave the employ also for many other reasons besides the natural causes, and consequently the concrete meaning for T decreases, thus lowering the average rate per hour if m, t and a remain constant. This can be readily seen from equation (1) where T is one of the factors in the numerator of a fraction.

For the sake of precaution all the above calculations were made on supposition that the concrete meaning of T is determined by the natural causes. In reality the meaning of T as determined by statistical data will be considerably higher

and therefore all the above is an ample proof that periodical increases of wages will not cause an increase of the total costs of production.

Equations (1) and (2) express the mathematical relation between all the factors that influence the average rate, and enable us to find suitable meanings for some of them if the rest are known.

The meaning for T cannot be chosen, but is determined by the statistical data, then y is found from the equation

$$y = \frac{100}{T} \quad p, m \text{ and } a \text{ are determined by existing standards}$$

of wages. For instance, in case the lathe department of Dvinsk Railroad shops, where the average age of the workmen is 35 years, the starting age is 20, and the average rate is 28 cents per hour, we will have

$$\frac{20 + (20 + T)}{2} = 35; 40 + T = 70; T = 30 \text{ years.}$$

consequently

$$y = \frac{100}{T} = \frac{100}{30} = 3\frac{1}{3}, \text{ or } 3.3\% \text{ approximately.}$$

If $p = 28$ cents, then, considering the standards of wages at the present time in Dvinsk shops, $m = 1$ and $a = .6$ would be most suitable.

Considering that the exchange of workmen is due but to natural causes, and that under these circumstances $T = 40$, we can, from equation (1), determine the meaning for t

$$t = \frac{mT}{2p(1-a) + m} = \frac{40}{56(1-.6) + 1} = \frac{40}{23.4} = 1.7 \text{ approximately.}$$

$$\text{If } t = 1.7, \text{ then } n = \frac{T-t}{t} = \frac{40-1.7}{1.7} = \frac{38.3}{1.7} = 23 \text{ ap-}$$

proximately. 1.7 of a year being the average period of time between two consecutive increases in wages should be taken as a basis for constructing the scale of wages.

If $p = 28, m = 1, a = .6, t = 1.7,$ and $n = 23,$ then:
 starting wage rate $p_1 = ap = .6 \times 28 = 17$ cents per hour (approx.)
 highest wage rate $p_2 = \beta p = ap + mn = 17 + 23 = 40$ cents per hour (approx.)

or the starting wage rate will be 40 per cent below the average and the highest wage will be 43 per cent above the average and about two and a half times the starting wage rate. This difference between the starting wage and the highest wage gives ample impulse to the workingman to increase his efficiency so as to earn more, and at the same time will keep him in the same shop, probably in a new shop he will have to start again from the bottom.

In conclusion the method of distribution of surplus earnings is important. Various systems take care of these surplus earnings in different ways. The Taylor and Prussian-Hessian systems pay it all to the workmen, and bonus systems (such as Rowan's, Helsey's, or Siebenfreud's) pay to the workmen but a part, retaining the rest. Either of these methods is equally applicable to the new system, but it would seem that the retaining of any portion of the surplus earnings by the employer is unjust, because he gets his share from the increased output per same running expenses. Of course, it may be claimed that in many instances the employer keeps some men in the shop simply out of sympathy, although their efficiency is much lower on account of old age, and therefore the retained surplus earnings go to cover the deficiency of such men.

The wages and efficiency of an average workman are presented graphically in Fig. 2.

The efficiency of a man at about 20 is practically normal; later on, with years, he acquires skill and experience, his efficiency increases, and at about 40 it reaches its highest point. Then it begins to decline, slowly at start, and more rapidly later on, and at about 55 it falls below the normal.

At the same time the wages at the start will be much lower than the average, and even at the time of his highest efficiency he will get a rate below the highest. Later on, however, although his efficiency has decreased, yet until the product of his co-efficients of efficiency, quality and attendance will be still above 1 he will continue to receive increases for his work. Only at about 45 will he receive the rate corresponding to his efficiency at that time. Therefore, the increases of earnings which he will get after 45 will compensate him for the inadequate earnings during the previous years. At 55 years of age efficiency will come down to normal, the increases are stopped, and he gets the last highest wage for the rest of the time. The wage scale being constructed on assumption that $T = 40$, therefore if a man will work even up to 60 years of age, the employer will suffer no losses.

The systems that give all the surplus to the employee usually do not care what becomes of the man when he reaches the point where his efficiency falls below the normal, simply throwing him out, and the systems that retain some portion of the surplus and keep some men in the shop out of sympathy have to bear the burden, and in case there is too much sympathy it may happen that the retained surplus will not be enough to cover the extra expenses.

As I mentioned before, either of the methods is applicable to the proposed system, but it would probably be more rational to retain a portion and apply it to the formation of a pension fund.

At present in most cases the workingman living from hand to mouth is left entirely unprovided for when old age comes, and this compels him to stay in the shop until his last strength gives out. But if there will be some pension provided, which as suggested could be formed out of the retained portion of surplus earnings, it would, on the one hand, assure this old workman a small income, and on the other, relieve the employer from the extra expense incurred by keeping the old man in employ out of sympathy. This would release his place for a more efficient hand.

The organization of shops is one of the most important factors of progress in industries, and the system of wage payments is one of its vital elements. Therefore, the question of deciding upon the right system to be adopted in a modern industrial organization should be considered very seriously.

LIMITATIONS TO THE CAPACITY OF COAL CARS

About twenty years ago the introduction of the steel coal car of 50 tons capacity was a distinct advance in increasing the size of coal carrying units and effected considerable improvement in the ratio of paying load to the gross load of the car. During the past few years there has been a progressive tendency toward a still further increase in the capacity of coal cars, marked first by the development of the 57½ ton car and passing through successive steps of 70, 75 and 100 tons capacity to the present maximum of 120 tons capacity, several of which are now in service. It is evident that there must be a limit to the extension of this development, determined by the strength of track and bridge structures and clearance limitations.

A study has been made by the Pennsylvania Railroad to determine this limit, from which it is concluded that the maximum has already been reached and that permissible axle loads offer no opportunity for its extension. This investigation took into consideration bridge loading, practical limitation of wheel loads, and the location of center of gravity of the loaded car. The bridge limitations were assumed to be Cooper's E-60 bridge loading, which places a limit on the weight of the car of 6,000 lb. per linear foot

of coupled length. The maximum wheel loading which the rails are capable of supporting without undue deformation was assumed to be 52,500 lb. per axle, the maximum for a 0-in. by 11-in. M. C. B. axle. This is a larger size axle than is now in common use, although the Pennsylvania Railroad now has something over 30,000 cars of 70 tons capacity under which four-wheel trucks with axles of this size are in use.

The maximum axle loading was determined on the basis of the results obtained by the sub-committee of the American Railway Engineering Association on Rational Relations Between Intensity of Pressure Due to Wheel Loads and Resistance of Rail Steel to Crushing and Deformation, in a series of tests conducted on the rolling test machine at the Sparrows Point plant of the Bethlehem Steel Company. On this machine a five-foot section of rail was caused to travel a distance of four feet back and forth under a chilled cast iron car wheel revolving on roller bearings, through which the load was applied. The test specimens were taken from a new Pennsylvania standard section 100-lb. rail. The effect of the load on the metal at the head of the rail was determined by observing the closure of a series of 3/32-in. standard taper holes placed horizontally below the surface of the tread, approximately 1/8 in., 3/16 in., 1/4 in., 5/16 in., and 3/8 in. The closure of the holes was observed by the use of taper plugs with markings approximately 1/8 in. apart along the taper, so that the difference in diameter between any two consecutive marks was as near as could be measured .001 in.

In the first test, beginning with a load of 30,000 lb., 110,000 passes of the rail were made under the wheel. The load was then increased to 35,000 lb. and 120,000 additional passes were run. The first 50 passes of the wheel indicated that all of the horizontal holes were closing. After 500 passes all of the horizontal holes had closed by amounts varying from .001 to .003 in. in diameter. From this point closure of the deeper holes became very slow. The average width of the contact of the wheel on the rail increased slightly at an approximately uniform rate throughout the test and the contact area gradually moved toward the gage side of the rail. The average area of contact increased from .3 sq. in. after 10,000 passes to approximately .475 sq. in. at the end of the test, but the change proceeded in an erratic manner.

The initial passes of the wheel over the first rail specimen indicated an immediate closure of the holes, extending even to the deepest holes, 3/8 in. below the surface of the tread. The test of the second specimen was started with a light load of 15,000 lb., increasing successively to 20,000

lb., 25,000 lb. and 30,000 lb. With a load of 15,000 lb., 25,000 passes were run and no closure whatever was observed. After 26,000 passes had been run with a load of 20,000 lb., no closure was observed. Throughout these two periods of the test, however, the width of contact constantly increased and the path of the contact gradually moved toward the gage side of the head. A very slow closure of from .0005 in. to .0015 in. was noted in the holes nearest the tread after 110,000 passes had been run with a load of 25,000 lb. The load was finally increased to 30,000 lb. and 105,000 passes run, with the result that an additional closure of from .005 to .0012 in. was noticed in the holes nearest the top of the rail.

During the entire test no closure was observed in the holes 5/16 in. and 3/8 in. below the surface of the tread. Comparing the first with the second test, it should be noted that with an initial load of 30,000 lb. all the holes had closed by amounts varying from .0035 in. in the deeper holes to .0085 in. in the holes nearer the surface, at the end of 110,000 passes. Scleroscope readings clearly indicated an immediate hardening of the surface under the wheel which gradually increased during each test. There is no proof that the maximum hardness through the cold rolling had been reached at the termination of either test.

With a maximum of 52,500 lb. load per axle the maximum permissible total weight of car and lading is established at 315,000 lb., using six-wheel trucks. To meet the requirements of Cooper's E-60 bridge loading, the coupled length of such a car must not be less than 52 ft. 6 in. On the basis of this length the height from the rail to the center of gravity of the car was determined to be 6 ft. 6 in., which is the upper limit of safety. To reduce this height the length of the car must be increased.

The net weight of coal in the load of such a car obviously depends upon the light weight of the car. In the study made by the Pennsylvania Railroad this is estimated to be between 75,000 lb. and 80,000 lb., which gives a ratio of paying load to gross load of, respectively, 76.2 per cent and 74.6 per cent. Assuming that the lower limit of light weight be attained, the total weight of the load in the car will be 240,000 lb. or 120 tons.

As far as conclusions may be drawn from these tests, it appears that a load equivalent to a 60,000-lb. axle load effects a working of the metal in the head of the rail for a considerable depth. Such a load is probably too high to be imposed on the rail through a small diameter wheel. When previously subjected to the rolling action of a much lighter load, the depth to which the metal of the rail is worked by the high load is materially reduced.

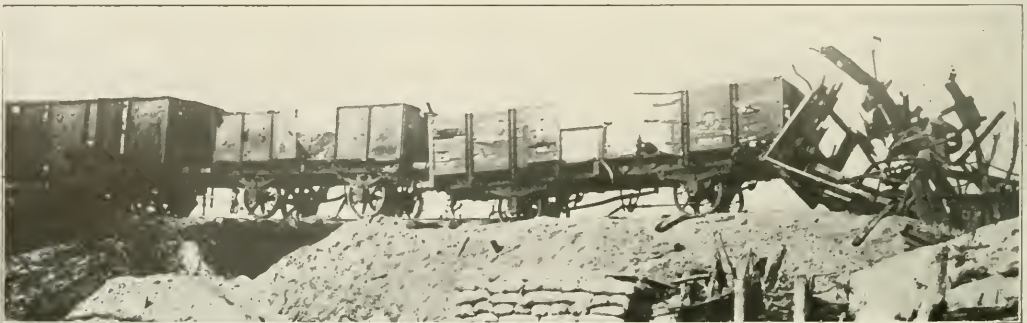

Copyright by Underwood & Underwood

What Happens to Railway Cars on the British Front

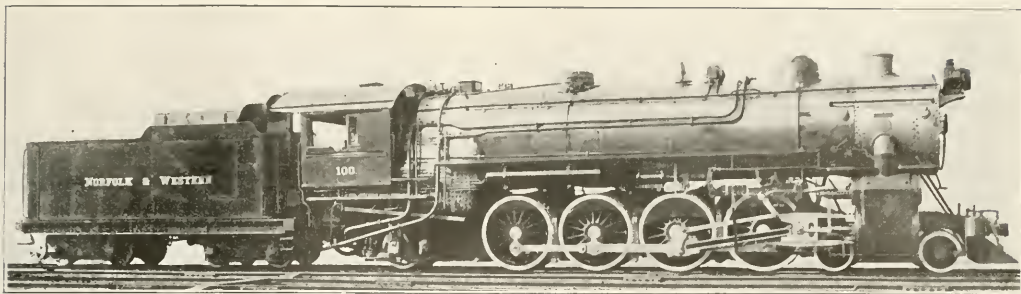

DRAFTING MODERN LOCOMOTIVES

Improvements Effected by a Study of Draft Conditions on Norfolk & Western 4-8-2 Type Engines

BY H. W. CODDINGTON

Engineer of Tests, Norfolk & Western, Roanoke, Va.

I

THE lines of the Norfolk & Western, as they pass through and over the Blue Ridge and Allegheny mountains in their course from the Atlantic coast to the Ohio plains, have encountered many natural obstacles, among which heavy mountain grades have been the most difficult to avoid. These heavy ruling grades in the mountainous regions have encouraged the continued development of larger and more powerful power units, of which the Mallet type locomotive is an expression for freight service, while the mountain type locomotive is the result of the effort to meet the demands of heavy passenger service through the same districts.

In the summer of 1916, the Norfolk and Western designed and built in its shops at Roanoke, Virginia, six mountain type locomotives. These locomotives are stoker-fired and are identified by the road as class K1. The general dimensions are as follows:

Type	4-8-2
Service	passenger
Total weight	347,000 lb.
Weight on drivers	236,000 lb.
Cylinders	29 in. by 28 in.
Steam pressure	200 lb.
Diameter of drivers	70 in.
Total heating surface, including superheater (36 elements)	4,863 sq. ft.
Grate area	80.3 sq. ft.
Tractive effort	57,200 lb.

When the first group of class K1 locomotives was placed in service, some trouble was experienced in maintaining a satisfactory steam pressure, and while it is true that the engines rarely completely failed for steam, it is equally true that some of them operated on a very narrow margin, barely making the schedule under the most favorable conditions. These engines are provided with boilers of liberal dimensions and confidence was expressed that the trouble was not due to an insufficient boiler capacity, but probably centered about some question of combustion. In view of this, it was decided to make observations and later conduct some experiments after making certain proposed changes in the locomotive front end. The changes anticipated were along the line of a larger exhaust stand, a larger nozzle and a larger stack.

Engine No. 100, which was regularly assigned to through passenger service, was selected for these observations. This locomotive was considered to be perhaps the poorest steaming locomotive of the group. The locomotive was shopped for

the application of the necessary test equipment, consisting of draft gages, steam indicator, speed recorder, signal systems and pressure gages. Pitot tubes were provided along the length of the stack for determining the position of the exhaust column. Provision was also made for obtaining samples of combustion gases. The first preliminary observations were made on January 3, 1917, on train No. 25, between Roanoke and Christiansburg, Virginia. This type of locomotive should carry, normally, 200 lb. steam pressure, but on this run it was observed that the steam pressure ranged from 157 lb. to 192 lb. It was also observed that the draft was unusually low, indicating the necessity for improvement in this respect.

The test runs were all made in the district referred to in the preceding paragraph. A train of empty passenger equipment cars was provided and the train was operated out of Roanoke as a second section of some passenger train. This district presents an opportunity for observation both under high speed and heavy grade operating conditions. From Roanoke to Elliston, Virginia, a comparatively level or undulating grade is traversed for about 20 miles, while from Elliston to Christiansburg a heavy mountain grade of 1.32 per cent is encountered for a distance of 13 miles. While observations were made under conditions of high speed from Roanoke to Elliston, it was observed that the operating conditions on the mountain grade were more uniform and presented a better opportunity for obtaining consistent data than in the high speed district. It was also possible to make several trips on the heavy grade between Elliston and Christiansburg each day, which would not have been possible had an attempt been made to cover the complete district from Roanoke to Christiansburg. Therefore, only the data compiled from the observations made while operating on the heavy grade will be presented. During these runs an effort was made to maintain an average speed of 32 miles an hour.

The first test run was made March 9, 1917. In this test an opportunity was afforded for establishing the proper location for operating the reverse bar and throttle, as well as the train tonnage. The position established for the reverse bar was the eighth notch from the center, which gave approximately 57 per cent cut-off, while a full throttle was maintained at all times. The weight of the train ranged from

600 tons to 640 tons, the tonnage being varied as suggested by changes in the locomotive. For instance, when the engine was provided with a larger nozzle, which resulted in reduced exhaust pressure, it was found that an increase in tonnage was required in order not to exceed the desired speed. Before any alterations were made in the front end a complete test was made of the locomotive in its original condition to obtain data for use as a basis for comparison.

In considering the possibility of improving the draft conditions upon this type of locomotive, the results of draft tests conducted by Dr. W. F. M. Goss, as reported in his book entitled "Locomotive Performance," were carefully studied. It was found, however, that the formulae established by Dr. Goss in his study of front ends conducted upon small locomotives did not apply readily to the larger types of locomotives, of which the Norfolk & Western class K1 is an example. Hence the study of this problem was in a measure elementary; the developments were the result of the study of the data obtained from each individual day's run and not the result of following a preconceived program. The results from every test conducted have not been presented, as there were some for which the data were not of an enlightening character, and these have necessarily been eliminated in the final compilation.

In the preparation for the test, the engine was equipped on one side with a Crosby steam engine indicator and a steam gage connection to the exhaust passage in the cylinder.

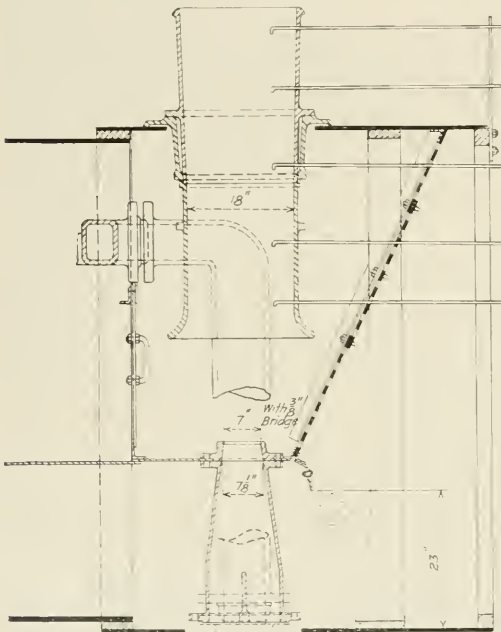

Fig. 1—The Original Front End Arrangement of the N. & W. Mountain Type Locomotives

Along the length of the stack, at intervals of approximately 10 in., were five Pitot tubes extending through the stack and front end space to the front of the locomotive. The outside terminal of each of these tubes was attached to an open mercury manometer tube for establishing the position of the exhaust jet with reference to the inside surface of the stack. The position of the Pitot tubes when a zero reading on the manometer was registered indicated the position of the edge

of the exhaust jet. The location of the Pitot tubes is shown in Figs. 1 and 2.

Cab readings were taken of the boiler pressure, draft at three different locations in the boiler, position of reverse bar and throttle, location, time and speed. One of the observers in the locomotive cab operated an electric signal system which announced to the observers on the front end when observations were to be made. An annunciator located in the locomotive cab was employed so that the observers on the

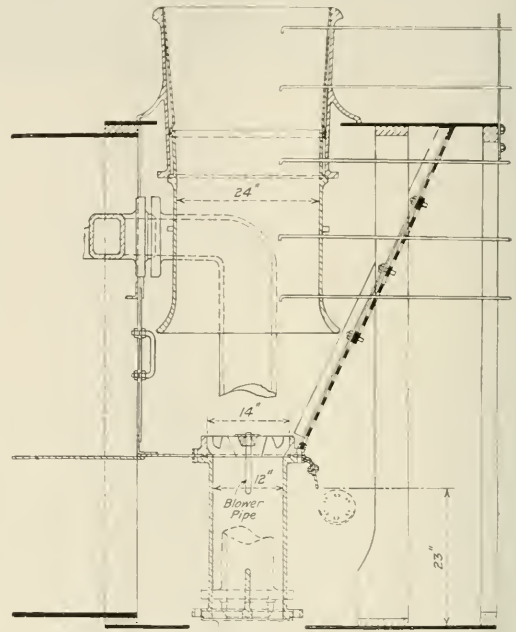

Fig. 2—Front End Arrangement of the N. & W. Mountain Type Locomotives Developed as the Result of the Drafting Tests

locomotive front could signal when their observations were completed. In this manner all of the observations were made at approximately the same time and under the same conditions of performance. Provision was made for obtaining a sample of the combustion gases while the trip was in full progress, a continuous sample being taken for a period of six to eight minutes. Samples of the fuel used were obtained by the cab observers at intervals throughout the test trip and later analyzed.

The tender behind the locomotive was fitted with water gages and the water consumption for each trip was observed. Care was exercised to have the locomotive standing on track of the same gradient with the same amount of water in the boiler at the beginning and end of each trip.

The test runs made were 74 in number and covered a period from March 9, 1917, to July 27, 1917.

Fig. 1 represents the front end arrangement which was standard for the mountain type locomotives at the time the engine was taken out of service. The arrangement consisted of an 18-in. diameter stack with a 26½-in. inside extension and a plain circular 7-in. diameter nozzle with a ¾-in. bridge, having a free area of 35.86 sq. in. The arrangement adopted as standard as a result of the investigation is shown in Fig. 2. It consists of a 24-in. diameter stack, 26½-in. inside extension and a 14-in. diameter annular waffle iron nozzle having an effective area of 49.35 sq. in. The results

obtained from these two front end arrangements may be contrasted as follows:

Front end arrangement	Original	Modified
Run number	17	74
Type of nozzle	3 $\frac{1}{4}$ -in. bridge	A-42
Speed, miles per hour	33	29.5
Boiler pressure, lb. per sq. in.	192.5	200.2
Front end draft, in. water	8.91	8.63
Exhaust pressure, lb. per sq. in.	10.94	4.54
Draft efficiency	.029	.068
Area of nozzle	35.86	49.35

Representative indicator cards selected from runs No. 17 and 70 are presented in Fig. 3.

Draft improvement has been undertaken on the Norfolk

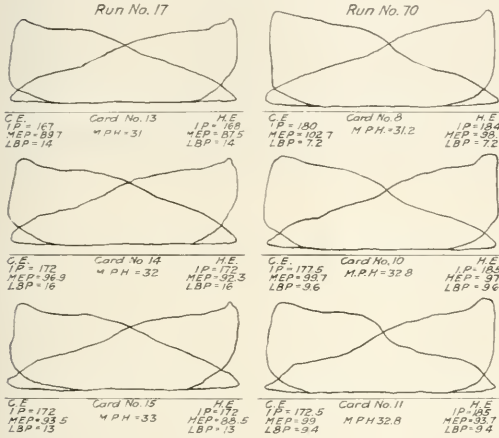

Fig. 3—Representative Indicator Cards Taken with the Original and the Modified Front End Arrangements

& Western's 4-8-0 type freight locomotives, class M-2. The same principles have been applied and good results obtained. The draft has been increased 39 per cent; exhaust pressure reduced 22 per cent; draft efficiency increased 76 per cent. The exhaust nozzle has been increased in size from 5 $\frac{3}{4}$ in. to an area equivalent to 6 $\frac{1}{4}$ in. in diameter. With still further changes, there is a possibility of improving upon the results already obtained.

The details of the tests and the sequence of the steps which led up to the final development, will be discussed in the succeeding articles.

(To be continued.)

COAL PRODUCTION.—Production of bituminous coal for the month of April, 1918, is estimated at 46,478,000 net tons, an increase of 4,400,000 tons, or 10 per cent over April of last year. Production for the four months ended April, 1918, is estimated at 181,992,000 net tons, an increase of over 5,000,000 net tons, or three per cent compared with the same four months of 1917, according to the reports of the Geological Survey. The output of bituminous coal declined slightly during the week ended May 4, the total production being estimated at 11,559,000 net tons. During the week ended May 11 there was a gain in production of 2.2 per cent over the week of May 4, exceeding slightly the record week of April 27, the total output being estimated at 11,806,000 tons. During the week ended May 18 there was a slight decrease, in coal production, the output being estimated at 11,732,000 tons, an average daily production of 1,955,000 tons, compared with a daily average of 1,829,000 tons during the month of May, 1917.

CONSERVE AND RECLAIM MATERIAL

The Railroad Administration has made through its regional directors a strong appeal for conserving material and reclaiming and repairing old material. The following is from a circular letter issued by C. H. Markham, regional director of the southern territory, to all the railroads under his jurisdiction:

In view of the increasing difficulty in obtaining a sufficient amount of iron and steel products, it is more important now than ever that every piece of material that is fit for further use, or that can be repaired and used, should be used in place of new material. Many articles of scrap by reworking may also be used, and the amount of new material required very considerably reduced.

Under no circumstances must any material be scrapped until it is positively known that:

First—It cannot be repaired by some process.

Second—Or that the cost of repairs by suitable means is prohibitive.

Third—Or that by some economical process, it may not be converted into another class of useful material.

Innumerable ways by which material may be reclaimed is already known to those in charge of the handling. From time to time, methods evolved on some particular road will be valuable to others. Articles and methods, with full description when necessary, should be sent to this office from time to time, so that they may be published for the benefit of the other regional roads.

Everybody should bear in mind that, due to the shortage of all supplies, many articles that under normal conditions could not be economically used again, can and must be repaired, if, by so doing, any saving of material, however small, can be effected. There are innumerable ways by which the desired results may be obtained, and in connection with the oxy-acetylene torch, and electric arc welders, material that formerly went into the scrap can be reclaimed and made almost as good as new. Worn parts can be built up in many cases without being removed. Flues and firebox sheets that under old conditions had to be removed, can be repaired and power kept in service that otherwise would be in the shop.

The use of reclaiming rolls for working up iron and steel scrap into rerolled usable sizes is a good proposition.

Any requests for apparatus or devices that will assist in the maximum utilization of material that would otherwise be scrapped, will be given proper consideration.

I would like each railroad to organize a reclamation committee, which will make a thorough study of each department, and keep me in touch with what is being done, making recommendations from time to time of devices or apparatus that will bring about the conservation of all kinds of new material.

Previous to the organization of the reclaiming committee, there should be appointed at once a committee consisting of a competent stenographer, a representative of the mechanical department, maintenance of way department and storekeepers' department, which should immediately start and go to all general storehouses, local stores, motive power shops, maintenance of way bridge and building shops, car inspectors' building, section houses, and maintenance of way material yards, to see that the following instructions are complied with:

1. See that all scrap, whenever found is noted and arrangements made to ship such as should be handled to the general stores immediately, a record being kept of such material as requires future handling to be done later.
2. Go over store stocks, material yards and arrange for proper distribution or disposal of any surplus material not required in a reasonable time.
3. Go over store stocks and material yards and arrange for the disposal of all obsolete material.
4. See that disposition be made of all articles held for possible future use at motive power shops, bridge and building shops and material yards, whose original use is so remote as to make it inadvisable to hold.
5. Visit all our inspection points and section houses, and see that arrangements be made for the prompt shipment of all scrap to central

joint, all obsolete and surplus material moved to general storehouses, to be later disposed of in the proper manner.

6. In general, see that all articles made in part or wholly of metals or rubber that are stored at any point for possible future use, but which there is no reasonable prospect of using, is immediately given proper disposition.

The following is a partial list of materials to be reclaimed and repaired, and methods to conserve the use of new supplies:

All bar iron stock of bolt sizes to be straightened and cut up for bolts. All bolts broken or with battered threads, to be cut to smaller lengths and rethreaded.

All brass fittings from parts of air pumps, injectors, lubricators, steam cages, cocks, etc., to be carefully examined and repaired if possible.

In scrapping articles which may be composed of one or more materials, if necessary, break them up and remove all brass.

Brake beams bent with broken or missing parts, straightened and new parts applied.

All forgings, which by straightening and repairing, can be re-used.

Scrap car axles to be drawn down to arch bar and drawbar yoke sizes and used for this purpose, and in any cases where there is a surplus of axles, they may be drawn into turret lathe stock.

All nuts, either loose or on broken bolts, to be retapped and put in stock.

Car journal bearings, where end wear is not excessive, to be relined. In connection with reclaiming rolls, scrap arch bars, drawbar yokes and other heavy scrap to be rolled into bolt stock.

Worn coupler knuckles can be built up by oxy-acetylene, and used on work cars, yard engines, etc.

Where a grey iron foundry is operated in connection with the railroad plant, no cast iron should be sold, but all scrap utilized. All castings which are fit for further use or may be repaired, should be given the closest inspection.

All structural steel should be cut apart and shapes thus secured frequently can be utilized in repairs to steel cars, etc.

Old tin car roofing should be burned and the spelter melted and collected.

Coil springs, where not broken, should be heated, reset and retempered. Broken coil springs should be straightened, and bar steel used for manufacturing track tools, pinch bars, cold chisels, etc.

Elliptic springs with broken leaves should have the broken leaves replaced and the springs returned to storeroom. Coil springs, where through worn waste from passenger equipment after reworking and if not fit for passenger equipment should be used in freight service.

All dirty wiping waste should be reworked by steam cleansing in a centrifugal washer.

Couplers, knuckles, hydraulic or power jacks, draft gear and parts, chains, pipe fittings, journal boxes and truck frames, where through accident or other causes, are found on line of road, should be promptly sent in to some shop, where this second-hand material can be repaired and placed back in service.

There is a very great shortage of crude rubber due to the constantly increasing uses being found for it, and the supply not increasing in the same ratio as the demand. Would suggest in connection with your Reclamation of Material Committee that the subject be given careful consideration to the end that:

First.—All hose to be as small in size and short as possible consistent with the use it is to be put to. Check up car heating and washout plants particularly, as considerable saving can be made in some places.

Second.—Wire wound hose of less number of plies and at correspondingly decreased cost may often be substituted for special hose frequently used for withstanding high pressure.

Third.—Substitute lengths of iron pipe for hose wherever possible.

Fourth.—Discontinue the use of rubber mats and step treads in cars and other places where used.

Fifth.—Sheet rubber can often be replaced with composition packing at less cost and at same time conserving the supply of rubber.

Sixth.—Old rubber should be carefully collected and disposed of as scrap, promptly.

On account of the acute shortage of files, all worn files should be collected and where the facilities exist, resharpened, and when worn so badly they cannot be further resharpened, should be sent to file makers for recutting, and none scrapped until you are absolutely sure they cannot be further utilized.

Scrap.—On account of the shortage of iron and steel, the War Industries Board and the Council of National Defense call attention to the necessity for picking up and either selling or reclaiming every piece of scrap iron or steel, dismantled machinery, obsolete iron and steel material or machinery that can be found on each road.

The Railroad Administration directs that special attention be given this matter and all such metals and materials be disposed of to the best advantage as soon as possible.

Each road will please report to this office on or before June 30, 1918, what has been accomplished along the lines indicated above.

Equipment Exports from the port of New York in March, 1918, consisted of locomotives valued at \$964,492, freight cars at \$455,360, and steel rails at \$305,198.—*Bulletin of the National City Bank, New York.*

A DECADE OF PROGRESS IN BUILDING STEEL PASSENGER CARS

In order to ascertain the progress of the building of steel and steel underframe passenger train cars and to develop the cost of reconstruction in steel of the present wooden equipment of the country the Special Committee on Relations of Railroad Operation to Legislation sent certain requests to the carriers on January 2, 1918. Replies were received from 434 roads operating 246,224 miles in the United States and 64,816 passenger train vehicles, and with 966 under construction on January 1. Replies were also received from eight companies operating 33,269 miles in Canada, with 5,422 passenger train vehicles, and with 35 under construction on the same date. Estimates and percentages in the tables apply only to cars operated by roads in the United States.

It will be noted that there were but five wooden passenger train cars constructed in 1917 and that but 27 such wooden cars were under construction on January 1, 1918, indicating that the building of wooden passenger train cars has practically ceased.

ANNUAL ADDITIONS OF PASSENGER EQUIPMENT

Acquired in	Total number	Percentage	
		Steel underframe	Wood
1909.....	1,880	26.0	22.6
1910.....	3,638	55.4	14.8
1911.....	3,756	59.0	20.3
1912.....	2,660	68.7	20.5*
1913.....	3,350	63.0	30.4*
1914.....	4,495	74.6	29.9*
1915.....	1,696	73.7	20.1*
1916.....	1,443	92.5	7.3*
1917.....	2,780	62.5	37.3*
January 1, 1918 (under construction).....	966	90.8	6.4

*This figure includes wooden cars reconstructed with steel underframe.

The rapid increase in steel and steel underframe cars is shown below:

Approximately in service	Steel underframe
January 1, 1909.....	626
January 1, 1910.....	1,117
January 1, 1911.....	3,133
January 1, 1912.....	5,347
January 1, 1913.....	7,271
January 1, 1914.....	9,492
January 1, 1915.....	12,906
January 1, 1916.....	14,286
January 1, 1917.....	15,734
January 1, 1918.....	17,661
Increase 1918 over 1909.....	16,972
Per cent increase 1918 over 1909.....	2,698
Per cent increase 1918 over 1917.....	11.7

The number of wooden cars in service on January 1, 1912, was 48,126. There are now in service approximately 38,876, indicating the retirement from service of 9,250 cars in six years.

APPROXIMATE COST OF REPLACEMENT OF WOODEN CARS WITH CARS OF STEEL

	Number	Average cost*	Amount
Postal.....	158	\$19,000	\$3,002,000
Mail and baggage.....	2,236	17,500	39,130,000
Mail baggage and passenger.....	572	17,500	10,010,000
Baggage and passenger.....	3,205	17,500	56,087,500
Baggage or express.....	6,998	14,800	103,570,400
Passenger.....	20,727	23,000	476,721,000
Parlor, sleeping, dining.....	3,978	37,000	147,186,000
Business.....	726	26,000	18,876,000
Motor.....	276	35,000	9,660,000
Total.....	38,876		\$864,242,900
Annual interest charge at 5 per cent.....			\$43,212,145

*The cost figure is the same as used a year ago.



THE RAILWAY SHOP TOOL ROOM

One of the Most Important Departments. Its Efficiency Is Reflected Throughout the Entire Plant

BY M. H. WILLIAMS

IN many respects the tool room in a railway shop is one of the most important departments, the relative grade of work of the entire shop being largely influenced by the standards set by it. Moreover the ability to design and manufacture special jigs, fixtures, tools and appliances for economical manufacturing in the general shop will largely govern the cost of all work produced. Where the tool room sets a high standard of accuracy it will generally be found that other departments will eventually follow suit; but let the tool room become careless about tools manufactured, and workmen using the tools will get the "don't care" habit, the resultant poor work being evident throughout the entire shop. It follows, therefore, that the tool room instead of being in one corner, should be strictly in the limelight, and if anything, over-equipped for the work to be done.

Railway tool rooms are called on to manufacture a great variety of articles, probably as many as the tool rooms of many large manufacturing concerns. As illustrations, mention may be made of special taps, thread dies, reamers, gages, drop forging dies, forging machine dies, hammer dies, milling cutters, shear blades, punching dies and punches and a thousand and one special appliances. Many of these must be very accurate and should be equal to similar tools made by the best tool making concerns. This high grade and miscellaneous output naturally requires a very up-to-date equipment of machines and small tools and also suitable measuring instruments to properly measure and prove the accuracy of the tools manufactured.

One of the first requirements for the tool room is to be able to judge when a tool is made correctly, this referring to size, finish, hardness and general design. For the reputation of the railway, each tool manufactured should be equal in all these points to tools of similar class made by other manufacturers. No tool should be allowed to leave the tool room until it is correct in all respects. If this rule is well established, the tool room will receive the respect of the entire organization.

MICROMETER CALIPERS.

For measuring the various kinds of tools that are to be manufactured, it is a question if there is any tool better suited to the requirements than the micrometer calipers as regards accuracy and convenience to the workman. Certain standards may be considered desirable for reference gages

and in the larger shops, but for the average shop these calipers and the standard reference pieces generally accompanying them will meet most all reasonable demands. Micrometer calipers are expensive as compared with plain machinist's calipers and often at first appear difficult to use, but the workmen soon become accustomed to them. The result of their use is better workmanship, and fewer spoiled jobs, which will soon offset the cost of the calipers.

In these days, on account of the demand for expert workmen in manufacturing concerns, railway men who can caliper closely with machinist's calipers are on the decrease. With micrometer calipers a comparatively inexperienced man can caliper closer than an expert with hand calipers.

To meet ordinary requirements, the tool room should be supplied with micrometer calipers of sizes to suit the tools generally manufactured or required for the general shop. A set of outside and inside calipers varying by 1-in. steps up to 12 in. will generally be sufficient. These should not be considered exclusively tool room appliances but should be kept in a case or rack and given out on tool checks to men working on jobs in the general shop where the accuracy can be improved by close calipering. It is advisable where possible to measure and inspect each tool made by a man using micrometer calipers. This may look like an unnecessary refinement, but it will soon result in the workmen getting into the way of doing excellent work through knowing that their work is to be carefully checked.

There are a number of cases where micrometer calipers are essential and superior to ring gages, as in making reamers where the diameter should be slightly over size to allow for grinding after hardening. Taps should also be made a trifle large to allow for wear. All kinds of solid cutters for boring work, shafting, bolt sizes, gages, arbors, piston rods, valve stems, car axles, etc., should be tested for size by micrometer calipers. In the case of piston rods, the necessity is well understood of grinding or finishing them to one diameter for the entire length of surface passing under the packing, to prevent wear in packing and steam leaks. With micrometers the size of the rods can be measured at various places and the variation, if any, ascertained in exact thousandths of an inch. A limit can be set to govern the amount these rods may vary and .004 in. is recommended as satisfactory and not difficult to maintain. If this is established, all rods coming within this limit would be

accepted and used. Rods not finished within the limit should be corrected. The workmen will then know just what is expected and can work accordingly. Solid gages cannot be used on piston rods on account of the many different diameters.

For fitting crank pins and axles into the wheel centers, micrometer calipers can be used to good advantage. In this case the hole is usually measured with inside micrometers and the axle or pin machined a few thousandths of an inch larger. The amount allowed will vary with different metals and the results will be much more uniform than with the older practice of using machinist's calipers and making allowances for force fits according to each man's judgment.

Micrometer calipers are almost indispensable for the miscellaneous force and for shrink and running fits such as the tool room is called on to make; for instance, turning new shafts for cranes, motors or machine tools. In many cases the defective shaft can be calipered and a drawing made of it, which will enable the new shaft to be machined to the exact size required without throwing the crane, motor or tool out of service except for a very short time. Where the size of the shaft required is known to the thousandths of an inch, there is absolutely no reason why a new one cannot be made to fit perfectly. This is well illustrated by the way repair parts for automobiles fit.

THREAD MICROMETERS

In most cases railway tool rooms are called on to manufacture a number of odd sized taps, threaded pieces, thread gages, etc., peculiar to the road on which they are located. The drawings for these generally specify the diameter, threads per inch, and the form of thread, such as United States, sharp V, Whitworth, etc. Where these drawings go to several shops, there is always the possibility of the taps or parts not being interchangeable and not fitting properly unless some reliable standard is followed. Should standard gages be made at one shop and distributed to other shops they would be expensive and there is always the possibility of losing gages that are used only occasionally.

It is recognized that a thread to fit properly must have the correct outside diameter, pitch diameter and thread shape and for accurate testing thread micrometer calipers

outside diameter generally accompany the micrometers and are readily understood.

For the average railway tool room thread micrometers for measuring all threads up to 2 in. diameter will generally meet the requirements. For larger threads a choice can be made of purchasing larger thread micrometers or using the so-called three-wire system by which plain micrometers and wires are used. A description of this system is fully shown in text books.

The following two uses of thread micrometers will serve to illustrate their value. When making taps it is generally considered good practice to make them slightly over size so that the hole tapped will be a trifle large to allow the bolt to fit freely. This oversize may vary from .002 to .006 in. or more, as the case may be. With the use of plain micrometers, the outside diameter can readily be measured for any desired over size and the pitch diameter can likewise be measured. With these two dimensions correct, the flat surfaces at the top of the thread will also be correct. Assume that a 1-in. staybolt tap is desired .004 in. over size, 12 threads, U. S. form thread. The outside should be 1.004 in. and by consulting a catalogue or text book it will be found that for 12 thread U. S. form thread, the pitch diameter should be .0541 in. less, or 1.004 in. minus .0541 equals .9499 or practically .950 in., to which size the tap should be threaded.

When making taps there is always the possibility that they will change size when hardening, generally enlarging. For a 1-in. tap this may amount to .001 in. or more, depending on the grade of the steel. Allowances can be made for any variation expected as a result of hardening, which would be very difficult by other methods.

The tool room is often called on to make a sample thread or gage for a globe valve, say $1\frac{1}{2}$ in., 10 U. S. form thread. In this case the pitch diameter for 10 U. S. form thread is .0649 in. less than the outside diameter or 1.500 in. minus .0649 equals 1.4351 in. Finishing the outside to $1\frac{1}{2}$ in. and chasing the thread to a pitch diameter of 1.435 in. will insure a gage or thread of correct size and one that will be interchangeable with any other piece made to the correct size. Thread micrometer calipers can be recommended for use on every threaded article made in the tool room.

THREADING TOOLS

The threads that it is necessary to cut in the tool room should be as accurate as possible. As well known, it is a difficult operation to grind a lathe tool to the correct shape and angle for this purpose. The general appearance and accuracy of the threads will in most cases be improved by the use of the special threading tools sold for this purpose by a number of concerns. These tools have the bits or chasers ground with great accuracy by special holding appliances and will be found as a general rule more correct in form than tools made from solid steel with the average grinding. Such tools can be sharpened by grinding on the top surface and without altering their form. All things considered, they will be found cheaper in the long run than solid tools. For this reason and the improvement in workmanship, they should be introduced in the tool room and can be used to advantage for any lathe threading.

MILLING CUTTERS

On account of the many varieties of milling cutters used in railway shops no attempt will be made to describe their manufacture in detail but it is well to bear a few points in mind when special cutters have to be made.

Always bore the hole about 0.010 in. smaller to allow for grinding after hardening, or for an inserted tooth cutter with unhardened center, the hole should be ground. The hole and one hub end should be ground at one setting to insure the end running true. The second end after grinding

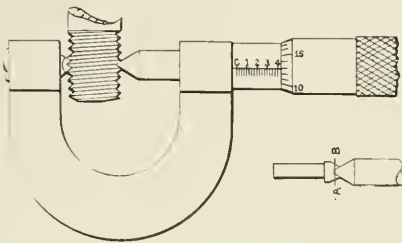

Fig. 1—Thread Micrometer Calipers

are almost indispensable. By their use it is possible to exactly duplicate threads at any shop with the assurance that they will interchange. Thread micrometers are quite common, but a brief description may not be out of place and one common form is shown in Fig. 1. This has the customary 40-thread micrometer screw with a pointed end that fits into a V block anvil. When the screw is run all the way down, the readings on the barrel show zero. When measuring, the V block is placed over a thread and the screw turned until its point just touches between the threads opposite the V block, the readings shown on barrel being the pitch diameter of the thread measured. Tables showing the amount the pitch diameter should be smaller than the

should be calipered with the first end in order to be sure that it is true and parallel. The size of the hole should be calipered with a plug gage and made correct to size as nothing is more annoying than a cutter that does not fit the arbor properly. In cutting the keyway, avoid sharp corners at the bottom, as they are liable to cause a crack when hardening. Also for the same reason, sharp corners should be avoided at the bottom of a tooth. Cutters should be ground on the face of the tooth as well as the outer edge. Cutters for wrought iron or steel work are better if the teeth are undercut or given about 10 deg. rake on the front face. A cutter with teeth spaced 1 in. to 1¹/₄ in. will cut as smoothly,

is generally made hexagon, *B* the punch, *C* a filler block and *D* the ram of the press. Attention is called to the filler block *C*. It is desirable that the end of any length of punch shall extend the same amount from the end of the press ram to avoid changing the stroke of the ram of the press. By making the punch and filler block together to equal one length for any length of punch, will eliminate the necessity of adjusting the stroke of the press. The nut as shown in Fig. 3 would have to be made with the thread suitable for each design of punching machine. It is desirable to make a separate nut for each size of punch head generally required.

Fig. 4 shows a form of die used quite extensively. In order to accommodate this die it will in some cases be necessary to re bore the die block. The bore should be of a size suitable for the largest die generally used on the punching press on which the die block is used. The smaller dies can be used in the same hole by the use of filler cups as shown in Fig. 5. This cup should be made of sufficient thickness at the bottom *A* to insure the tops of all dies being the same distance above the die block.

By following the method as outlined above any punch or die may be used in any punching machine. This will reduce the number of parts to be kept in stock and will meet the requirements better than a large variety of shapes and sizes.

For punching holes in angle irons or to meet special requirements, it may be necessary to make longer punches or higher dies. These, however, can generally be made with the same sized bodies and to fit the same holders.

Dies are at times made with a flattened side for a set screw to rest against for holding in the die block. With dies made correct to size this cannot be considered necessary, as a die will rarely lift in the die block. The set screw may be an advantage to prevent the die turning or coming loose. However, this is a question.

It is very essential that punches and dies be made correct to size and true, so that in the event of removing either it shall not be necessary to readjust the die block to line up with the punch. Generally the hole in the die block should be about .003 in. larger than the nominal size of the die, and the dies should be made to the nominal diameter to

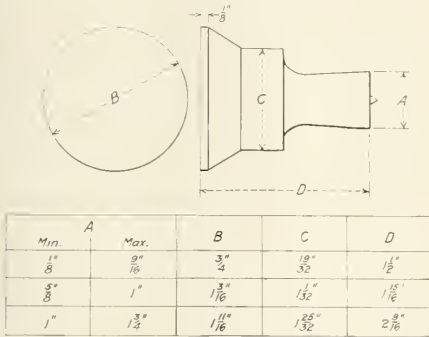

Fig. 2—Only Three Sizes of Boiler Punch Heads Needed

last longer and do more work than a cutter with teeth spaced 1/4 in. to 3/8 in. Cutters should be sand blasted after hardening, which improves their appearance and the smoothness of the surface. The make and grade of steel should be stamped on cutters for future reference and re-hardening; also the designating name or mark of the shop.

BOILER PUNCHES AND DIES

The tool room can without doubt save considerable expense to the general shops, and help out the boiler shop by standardizing a number of small tools such as boiler punches and dies. It is important that a stock of these be kept on hand of the sizes generally used, so that punching machines may not be held up. If the punching presses in the local shop or in the various shops on the system have different designs of holding nuts or clamps for holding the punch, it may often happen that special punches will be required for each press. That is, it may be necessary to make two or three designs of 9/16 in. punches.

By carefully studying conditions it will generally be found that the various punching machines can be altered and new holding nuts made so that one style of punch will be common for any punching machine on the road. For railway work it is necessary to change the sizes of punches and dies frequently. Therefore, the number of sizes of heads should be reduced to reasonable limits so that it will not be necessary to provide too many holding nuts for the punching press rams. On the other hand, if the steps in sizes are too great, it will make it necessary to make some of the punches with a small cutting edge and a large head, which is a poor design and requires a large amount of tool steel for the size of hole to be punched. Fig. 2 shows the form of punch made by a number of concerns that meets the requirements very well. The table of sizes is offered as a suggestion. It calls for three punches and covers all diameters generally required for boiler, tank and steel car work.

In order to hold these punches in existing punching machines it may be necessary to make new holdings nuts for the rams. One design is shown in Fig. 3 *A* being the nut, which

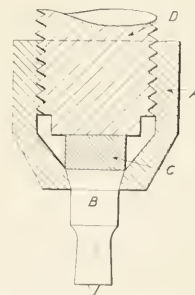

Fig. 3—Boiler Punch Holding Nut Arrangement

about .005 in. less. The punch should be true and the top surface square with the body to prevent throwing the cutting edge out of line and necessitating a readjustment of the die.

SQUARE WRENCHES AND SOCKETS

One annoying problem is that of keeping up the supply of wrenches, air motor sockets, etc. necessary for driving staybolt taps, reamers and applying staybolts. This is aggravated by the variety of sizes required. If the number of these sizes can be reduced, the conditions will be improved both in the tool room and the rest of the shop. For example, the square shank on a 7/8-in. staybolt tap is generally made 9/16 in. These taps do not require a great amount of power to drive

and as they do not bottom they do not receive the abuse incident to bottoming. Without a doubt staybolt taps of $\frac{7}{8}$ -in., $1\frac{1}{16}$ -in., 1-in. and $1\frac{1}{16}$ -in. can all be made with $\frac{9}{16}$ -in. square shanks, and the $1\frac{1}{8}$ -in., $1\frac{3}{16}$ -in., $1\frac{1}{4}$ -in. and $1\frac{5}{16}$ -in. can have $\frac{3}{4}$ -in. shanks without affecting their strength. By this plan two sizes of wrenches and sockets will be suitable for eight sizes of taps, as compared to eight, and the elimination of six sizes of sockets and wrenches. Also, where it is the practice to square the ends of staybolts and the head of button head or crown staybolts for screwing into the boiler, they can be made to one of these sizes. By this method one wrench or motor socket can be used for the larger majority of staybolt work. This will not only reduce the number of sizes of wrenches and sockets required, but when the workmen are on the boiler it will not be necessary to carry along a number of sockets. Another good result is that the proper sized socket will be used and thus reduce danger of accidents on account of wrenches slipping off the taps or bolts.

FORMS OF THREAD OF STAYBOLT TAPS AND STAYBOLTS

Three forms of thread are used by railroads for staybolts, namely, the sharp or V thread, the United States form and the Whitworth. It would hardly come within the province of the tool room to decide on the form of thread to be used, and no recommendation will be made in this article. The peculiarities of the different forms will be considered from a tool room point of view.

There are no well recognized standards of pitch diameter size for the V form of thread. While gages have been made by some of the leading tool concerns, they are not theoretically correct and not guaranteed to be so by the makers. To cut this thread to correct pitch diameter would make the top of the thread as sharp as a knife edge, which is not practical. As a matter of fact, staybolt taps of V form of thread are generally made from .012 to .018 in. larger at the pitch line than the theoretical size. On account of the difficulty of maintaining a standard for the V form of thread, it would be well for the tool room to get away from its use if possible.

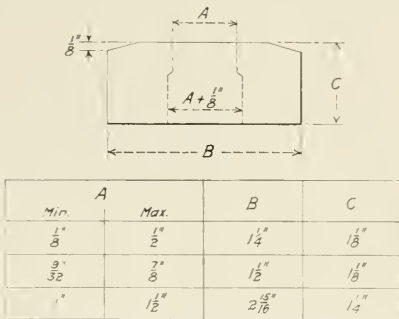

Fig. 4—Boiler Punch Dies Reduced to Three Sizes

United States standard form of thread is used almost exclusively in the manufacture of bolts, and the same form of thread, known as United States form (or U. S. F.) can be used to good advantage for staybolts. A very simple formula is given for the pitch diameter for any number of

threads per inch, as follows: Pitch diameter = $D - \frac{.6495}{N}$,

in which D is the diameter of the bolt or tap, .6495 a constant and N the number of threads per inch. For 12 threads per inch, as largely used on staybolts, the pitch diameter will be practically .054 in. less than the outside diameter, or a 1-in. bolt should have a pitch diameter of .946 in. This

form of thread has many advantages from the tool room standpoint. It is not hard to cut, can readily be measured with the thread micrometer caliper, and by establishing a limit governing the amount a staybolt may be under size or the tap over size, the bolts and taps can readily be made to interchange.

The Whitworth thread differs from the U. S. form on account of the rounded top and bottom of thread, and has a 55 deg. included angle instead of 60 deg., as used with the U. S. F. The pitch diameter is calculated by formula

$D - \frac{.649}{N}$, and for 12 threads the pitch diameter is about .001 larger than the U. S. form. The objection to this form



Fig. 5—Filler Cup to be Used With Boiler Punch Die

of thread from a tool room standpoint is that of cutting the rounded top and bottom of the thread, which should require a special ground tool for the purpose.

Boilermakers have discussed the question of the form of thread to be used from a number of angles, and there are no doubt advocates in favor of each form. As a matter of everyday shop practice in cutting staybolts, it is a question if threads cut to any of the three forms will vary enough to be noticeable. The flat surface at the top and bottom of the thread on a 12-thread U. S. form bolt should be .0104 in., or about .01 in. Examine a rule graduated to $\frac{1}{100}$ in., or if not handy, a rule graduated to $\frac{1}{64}$ in., and observe how small an amount this is. A slight dulling of the dies or chasers used to cut the bolts will remove the sharp corners of the U. S. form of thread and cause it to resemble the Whitworth. Also a slight dulling of chasers when cutting the V thread will cause it to appear the same as the two forms mentioned. Or, in other words, in the every-day practice of cutting staybolts on bolt-cutting machines, by the present methods, the condition of the chasers or dies will govern the form of the thread selected. The U. S. form has the advantage of well defined sizes and formulae, and is as easy to cut as any. Dies or chasers are easily maintained. It would also probably be easier to maintain the standards than with other forms. The latter will be an advantage to a tool room that is called on for tools in connection with staybolt work.

THREAD GAGES

The question of always having proper fitting bolts is very important in railway work, and in order to obtain interchangeability it is essential that a system of gages be provided for the workmen when cutting bolts. Ring and nut gages have been used for the purpose, but they are not all that is desired, on account of the time required to try on to a bolt.

For the general run of bolts such as are required for railway use, the thread gage shown in Fig. 6 answers very well. This can be obtained from a number of gage-making concerns. As will be noted from the illustration, it has two pairs of adjustable points, each of the same angle as the thread to be measured. The top pair is set to the maximum size of the pitch diameter allowable, and the lower set to the minimum size. This makes a "go" and a "not go" gage. The points can readily be adjusted to compensate for wear and to meet a reasonable amount of tolerances. With this form of gage, bolts can be tested with sufficient accuracy for the average

railway work, and on account of its ease of operation the workmen will make more frequent use of it than the ring gage. It is particularly useful when setting dies to the proper size, but will not detect a bolt out of pitch; that is, not having the correct number of threads per inch. This must be ascertained with screw pitch gages. Master gages, which can also be obtained from the manufacturers, must be provided for setting shop gages. One cheap form that answers very well can readily be made as shown in Fig. 7. This gage is threaded taper about $\frac{1}{2}$ thousandth per thread, or for 12

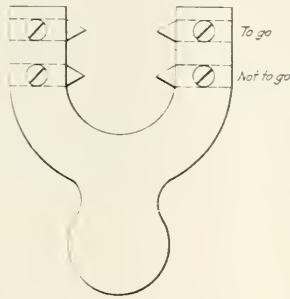

Fig. 5—A Convenient Form of Adjustable Thread Gage

threads per inch .006 in. taper per inch. It should be three to five inches long, depending on the pitch of the thread, and about $\frac{1}{4}$ in. thick. After hardening and grinding the sides, the thread sizes, both maximum and minimum, can be ascertained by a thread micrometer by calipering the various threads until sizes required are selected. Arrows or indicating marks to show the correct position on the gage can then be ground or etched on the flat surface.

The work thread gages should be proved or adjusted to the test gages frequently, depending on the extent to which they are used. It is advisable to seal the work gages when set, to prevent tampering with same.

The amount of tolerance to be allowed when cutting bolts and tapping nuts has not been well defined. The Ordnance Department of the United States recommends the following for close fits:

Number of threads	Bolt	Nut
4-6	-0.000	-0.006
7-10	-0.008	-0.008
11-14	-0.000	-0.006
15-18	-0.007	-0.000
19-24	-0.005	-0.002
	-0.000	-0.004
	-0.014	-0.014

All referring to pitch diameter.

These tolerances, it is believed, are no closer than necessary for railway work, and if the work gages for bolts explained above, are provided and used, the bolts manufactured will be interchangeable, and trouble from improperly fitting bolts and nuts will disappear. A bolt cut to minimum size and a nut tapped to maximum size will make a loose fit. However, this does not happen often in practice.

The principal trouble when threading on the average bolt cutting machine, the point or first part of the thread is generally smaller, owing to spring in the die head. By gaging about one inch back from the point, a general average will be struck that will satisfactorily meet all the requirements for bolts used on locomotive and car work.

STAYBOLTS

For staybolts it is generally advisable to provide work and setting gages for each size of bolt to be cut. The limit for this work should be fairly close, and it may require a few trials to determine the amount of tolerance necessary to meet the demands of the boilermakers and avoid too close work

on the part of the bolt shop. A limit of .004 in. below the theoretical size will not be found difficult to cut and will give good results. It follows that a 1-in. staybolt must be cut between the theoretical pitch diameter of .496 in. and the minimum size of .941 in.

The work gages and also the setting gages would have the following pitch diameters for U.S.F. threads:

Bolt size	Pitch diameter	
	Maximum	Minimum
$\frac{1}{8}$ in.	.821 in.	.817 in.
$\frac{1}{4}$ in.	.882 in.	.878 in.
$\frac{3}{8}$ in.	.946 in.	.942 in.
$\frac{1}{2}$ in.	1.008 in.	1.004 in.
$\frac{5}{8}$ in.	1.071 in.	1.067 in.
$\frac{3}{4}$ in.	1.133 in.	1.129 in.
$\frac{7}{8}$ in.	1.196 in.	1.192 in.

It is sometimes advisable to make the thread on the head or button end of crown bolts larger than the theoretical size, and in this case it may be desirable to set a limit of theoretical size to .004 in. above, in order that the bolt will screw tight into the boiler sheet.

MACHINE TOOLS FOR THE TOOL ROOM

Machine tools such as lathes, shapers, drill presses, universal and other grinding machines are too well understood to require special mention, and attention will be called only to a few features desirable for railway work.

Lathes.—It is a good plan to have at least one lathe equipped with a backing off attachment, which is useful when making formed or special milling cutters and also for relieving taps. Machine relieving is generally preferred to relieving by hand, and also gives a neater appearance.

Shapers.—The conventional shaper is a useful machine for tool rooms. However, too many should not be installed without carefully considering the relative merits of milling machines and surface grinders. The latter machines are often better adapted to certain kinds of tool room work.

Milling Machines.—The universal milling machine with index head, is indispensable for railway tool rooms. However, after one or two have been installed, it is advisable to consider other forms when increases in tool equipment are necessary. The large majority of tools, such as taps, reamers, dies, flue tools, etc., are milled without setting the table on an angle, and where a plain milling machine costing less will answer so much the better. The plain machine has the advantage of being more rigid, and heavier cuts may be taken, which will result in greater output. With the plain machine it will often be found that flat surfaces

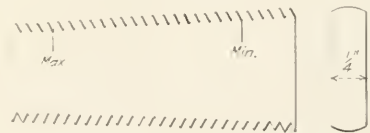

Fig. 7—Hardened Master Thread Gage

like die blocks for bolt headers, drop dies, blanks for bolt chasers, etc., can be milled quicker than shaping or planing.

For working out the depressions in drop forging dies, special form hammer dies, punching press dies of special shapes, forging machine dies, and precision drilling and machining odd-shaped articles, the vertical spindle knee type milling machine or the so-called drilling and milling machines can be used to good advantage. With machines of this nature many jobs can be milled that are now chipped. This class of machine can also be used for flat surface milling, by the use of face mills.

Grinders.—Most tool rooms are equipped with universal grinding machines, and these are too well understood to require comment. On account of the increasing use of spiral

milling cutters, both solid and inserted tooth, it is advisable to have one machine equipped with the special grinding attachment. This attachment may be used for grinding the face of the tooth of cutters. This will improve the cutting qualities and also reduce the time between grindings. With this attachment, the flutes in worn cutters can be ground deeper, and also when desirable to change the shape of the tooth, this can readily be done. This will at times eliminate annealing and rehardening.

For the larger tool rooms the plain cylindrical grinder can be used and effect considerable saving. It is a production machine and has the necessary strength and weight to remove metal quickly. For a number of jobs it will be found that grinding is quicker than turning and filing. Work such as arbors, shafts for motors, cranes and machine tools, drifts, round shanks of reamers and taps, etc., can be ground very quickly and with great accuracy. One good practice is to turn the shaft about $1/32$ in. large with coarse feed and finish on the grinder. In many cases where only a small amount of reduction in size is required, say $1/16$ to $3/32$ in., the piece can be ground direct from the rough bar much cheaper than turning. One good use for the cylindrical grinder is that of grinding the round shanks of reamers, taps and similar tools after hardening. This improves the appearance of the tools, and as the turning can be done in a rough manner, the grinding will not add to the cost of the tool. With one of these machines installed, new jobs will be found for it, so that it will not be idle. It will to a large extent take the place of a lathe and also relieve the universal grinders.

Surface Grinders.—The surface grinding machine is used only to a limited extent in railway shop tool rooms. It is, however, useful and economical for a large number of jobs. There are four general types, namely, the vertical shaft type with rectangular reciprocating table, the vertical shaft type with circular rotating chuck, the horizontal shaft type with rectangular reciprocating chuck, and the horizontal shaft type with circular rotating table. All of these can and should be provided with magnetic chucks. Each has its uses. The vertical type machines, which generally are equipped with ring or cup grinding wheels, will, under most conditions, remove metal faster than the horizontal shaft type, and may be considered largely production machines, which can be used for the tool work and also for a number of locomotive parts. The horizontal shaft machines are somewhat more general in their application for tool room work, but not as well adapted to locomotive work.

With the vertical shaft types a number of jobs can be ground cheaper than planing, and made more smooth and accurate. For example, work such as die blocks for bolt headers and gripping dies, if forged fairly close to size, can be ground from the forging quicker than planing. Steel used for chaser dies, boring bar cutters, double end cutters for boring car brasses, and cutter bits for various boring operations can be ground directly from the bar steel. In addition, a number of locomotive parts can be ground to good advantage, such as rod wedges, cross-head keys, slide valves, slide valve strips, etc. If forged or cast fairly close to size they can be ground quickly, and on the larger types of rectangular machines, locomotive guides and ends of main and side rods may be ground.

The horizontal shaft type with reciprocating table can also be used on the tools mentioned above, and in addition can be used for form grinding, such as the grooves in bolt or rivet header dies, and work of similar nature, on account of being provided with radius truing devices, by which the grinding wheels may be trued on the periphery to any half-circle desired. A machine equipped to grind the grooves in bolt and rivet header gripping dies will prove very useful, the method followed for new dies being to mill or drill the grooves a trifle small and grind to the proper size.

Also when the dies become worn from service they can be refinished by grinding a new flat surface and regrinding the grooves. This will eliminate annealing the dies when hardened steel is used, and for soft steel it will generally be found quicker than other methods. The customary method is to set the two halves on a magnetic chuck and grind both at once. The half-round grooves can be ground in about 30 minutes, including the time of changing and truing the wheel.

Surface grinders can be used to sharpen hardened punches and dies used for punching various odd-shaped pieces. By keeping these sharp, the appearance of the punchings will be improved and the dies will last much longer. They can also be used to grind the flat surfaces of gages, straight edges, parallel strips, sharpen shear blades, face sides or surfaces of bolt chasers or dies, finish the surfaces of cutting tools used in all forms of tool holders, and a large number of special appliances. This finish will be obtained very much quicker than by hand polishing and will have a much better appearance.

HARDENING AND TEMPERING

Furnaces for hardening and tempering need no description here. As far as possible, all tools should be hardened and drawn according to pyrometer readings. While it is true that a number of the tool hardeners in railway shops become very expert in judging heat by the eye, the fact remains that the conditions can be much improved by the use of pyrometers.

A record of each tool, or batch of tools hardened at one time will be found of value in the tool room. It should specify the kind of tool, make and grade of steel, degree of heat when quenched and kind of bath, degree of draw, time in hardening furnace, scleroscope hardness and any peculiarities. This record can be kept in a book, or better still on a card index. In the event of the tool not wearing properly or breaking, the record can be referred to, and proper modifications made for future tools, or should the tool wear well, the record will be a guide for future heat treatment.

THE SCLEROSCOPE

As a means for obtaining a uniform degree of hardness of tools the scleroscope is now being introduced into tool rooms, and the principle on which it operates is as follows: A small weight is dropped inside of a glass tube on the object to be tested, and rebounds, the amount of rebound being governed by the hardness of the object, and read on a graduated scale.

When testing soft steel with the scleroscope, the rebound may be 20 to 40 on the scale. For tools hardened to stand shocks, like chisels or flue tools, it may be 55 to 65, and harder tools, such as taps, may show 70 to 90. Practice with this instrument on tools that have given good service, will quickly enable any shop to set a standard for hardness that may be followed for tools manufactured.

When tempering tools there is always a possibility that they are not hardened to the proper degree, and even when a batch are hardened at one time some may be too soft or too hard. By testing each tool the hardness can be ascertained, and any not correct may be retempered. This will eventually result in a great improvement in the grade of tools manufactured. The amount of time required to test with this instrument is very small.

This article calls for a number of refinements not usually found in railway tool rooms, and at first glance some of the practices and appliances may appear out of place for tools used for locomotive and car construction and repairs. However, no tool or method is mentioned that is not common to most of the leading tool making companies. These companies are in the business to make money and naturally will not go into refinements if they do not pay.

EXPEDITE LOCOMOTIVE REPAIRS

A Well Knit Organization and Adequate Tools and Facilities Are Necessary in Shops and Engine Houses

BY GEORGE W. ARMSTRONG



WHILE the railroads through the spur of necessity have always been attentive to means for improving shop efficiency and output, there never has been a demand so insistently imperative as that which the country now makes that there shall be greatly increased efficiency in this and all other railway activities. An extra day spent in getting the shop work done on a locomotive or a few unnecessary hours' detention at the engine terminal, while seemingly of little moment, may be the indirect cause of losing a battle on the French front.

Every possible effort must be directed toward securing greater output per man, per machine, per pit and per shop. All must perform their parts in the great drama now being enacted, and the searchlight of improvement must be piercingly directed that every available facility shall produce its maximum.

In solving the problems of improved efficiency in mechanical department operations, two phases must be investigated which involve in the main different solutions, namely, the back shop and engine house.

The essential factors affecting general shop efficiency are:

1. Advance information as to repairs required.
2. Organization.
3. Scheduling and routing.
4. Material handling.
5. General shop equipment.
6. Centralized production.
7. Effective co-operation between mechanical and stores departments.

Similar factors relating to the engine house are:

1. Prompt movement of the engine to the engine house.
2. Thorough attention to minor defects.
3. General shop equipment.

One of the greatest aids in securing expedited repairs to locomotives in the back shop is the preparation of thorough advance information as to the repairs required, and while this practice is employed at present on a good many roads, it often has gradually degenerated to the mere perfunctory filling out of the necessary forms, and, therefore, does not accomplish the purpose intended. Especially important is the knowledge as to whether new cylinders, wheel centers, driving boxes, fire boxes, extensive boiler repairs and other machine details are required. Properly used, this information would enable the shop to prepare a greater portion of this material, so that when the engine is finally received, it will only involve removing defective portions and re-

placing them with the new parts, which can be done while repairs are made to the minor details of construction.

The prime essential at the shop is an effective organization, and without an organization that is responsive, aggressive and which will co-operate in every respect to secure the common aim of quick repairs and increased shop output, all other provisions for efficient operation will be neutralized.

You may force, fight or drive work through a shop, but you can never hope to attain the maximum if good feelings do not exist between the helper, mechanic, foreman, master mechanic or superintendent. Harmony is the oil that overcomes friction—and yet harmony must not be secured at the expense of discipline, or "abandoning a shop to the men," in order to avoid possible war labor complications. Firmness tempered with justice must be the prevailing sentiment.

One fault often found in railroad shops is an overburdening of the supervision. Effective results cannot be secured if a foreman or gang leader is not able to keep in touch with his men. The least frequently that he should see every man under his jurisdiction is every hour. The size for an effective unit organization will depend solely upon local conditions and the nature of the work. Obviously a blacksmith or machine foreman can supervise a larger body of men than one in charge of an erecting or boiler shop.

A scheduling and routing system* is absolutely necessary to secure expedited movement of parts requiring replacement or repairs and to insure prompt overhauling of locomotives. Aside from its wholesome effect in this respect, it is an excellent indicator of the essential degree of co-operation existing in the organization and will do much to bring the laggard into line. Scheduling and routing material relieves the individual foreman of the necessity for hunting and chasing material, thus affording greater opportunity and effective supervision of work. It keeps material moving, reduces delays and insures expedited output.

The results of organized scheduled effort have been demonstrated at various times in the past by record overhauling of locomotives in the various shops. While the experienced mechanical official realizes that back shop repairs made in from 20 to 36 hours are extraordinary results, still they are conclusive demonstrations of what can be effected to a lesser degree by utilizing the same implements, namely, thorough advance information as to the repairs required, co-operative effort, planning and scheduling of details.

Material handling undoubtedly offers one of the great-

*See the *Railway Mechanical Engineer* for August, 1913, page 423.

est obstacles at the present time in efficient shop operation. Unusual industrial demands to a great extent have absorbed the common labor, and what little is still to be found in railroad shops is extremely expensive, being mostly inexperienced help and commanding wages upon a par with that paid to mechanics prior to the war. Considerable thought, therefore, should be given to the utilizing of mechanical features as far as possible. While in a good many shops overhead cranes assist in handling of material from machine to machine or department to department, there is considerable hand trucking still necessary. A substantial saving can be made, not only in cost of handling this material through the shop, but also in the size of the force required by provision of floors and walks smooth enough to operate electric trucks, preferably those embodying an elevating feature, so that the work is delivered to the machine on a portable platform, removed from it to a machine and replaced by the machine operator after the work is completed and requiring simply to be lifted by the motor truck and readily transported to any point in the shop.

Another feature of the material question which should be investigated is the possibility of securing material from the storehouse for use at various points in the shop without the necessity of men leaving their work to go to the storehouse. This can be secured by reasonable anticipation of their wants and the installation of a messenger system, which can be developed in connection with motor truck operation as mentioned above. Orders for material may be left at different points in the shop, collected hourly and material delivered by motor truck despatch to the place required. A large loss in connection with the average shop operation is the waste through loafing to and from the shop and storehouse.

Another large factor requiring investigation at the present time is the necessity for better shop equipment. Size of equipment units have increased enormously, and in the greater portion of our shops no improved facilities have been installed to handle the larger units. Shops which were adequate for handling equipment averaging 200,000 lb. in weight are seriously overtaxed when required to repair modern Santa Fe and Mallet type locomotives, averaging from 350,000 to 500,000 lb. in weight. Machine tool facilities must be increased as well as erecting shop facilities, as not only are the parts in themselves larger, but the machine of today is vastly more complicated and requires more machining than the light consolidation of a decade ago. Not only has the equipment not kept abreast of the increase in size of power, but it has fallen behind the progress made in machine tool design and operation. Machine tools have been developed which will replace a number of lighter tools designed often solely to withstand the strains induced in using carbon steel tools. The draw cut shaper will largely increase driving box output and in itself perform the work formerly requiring a boring mill, planer and lathe. The vertical turret lathe will more quickly perform work usually done on a boring mill and in a good many instances replace a lathe, considerably reducing the set up time as well as the machining time.

Automatic machines have their possibilities also in connection with a locomotive shop, although unless the shop has a large output their use will not be warranted except in connection with centralized production for use at a number of shops and roundhouses. Set screws, studs and a large variety of similar parts can be cheaply finished on either single spindle or multiple spindle automatic screw machines.

The automatic chucking lathe is unexcelled for the manufacture of oil cup covers, grease plugs, tank hose nuts, air pump piston heads and a great many similar parts. Much cutting off of stock is done in connection with finishing in turret lathes where the installation of an inexpensive automatic power hack saw will reduce the time and expense

required in turret lathe operation, and due to an automatic chucking and feeding feature in duplicating stock of exact length, requires simply attention to insert a new bar.

One of the greatest aids to prompt turning of power at terminals and a big assistance in shop output is centralized production* of material capable of being finished partially or wholly in stock quantities. Its possibilities are large and its savings commensurate where a railroad has two or more shops and a number of outlying roundhouses. A constantly available supply of crosshead pins, knuckle pins, packing rings of various kinds, piston valve parts and bushings, oil cup covers and grease plugs, motion work pins, cab fixtures and numerous other things available for instant use at shop or roundhouse, the latter especially, often means the difference between a few hours or many hours delay in returning power to service.

Closely and intimately allied with centralized production is standardization of locomotive details.† While the development of efficient power requires adapting to operating conditions, a necessity precluding effective standardization of equipment, it is still possible and expedient to standardize details so as to result in reduction of material required in stock, enable quantity production of parts and insure prompt repairs.

All the good, however, accruing from the above factors will be nullified if there is not effective co-operation between the mechanical and stores departments. Material should be at hand in ample quantities to insure its availability when required, and yet not result in a surplus which is apt to deteriorate or become obsolete before used. An inspection of a good many casting platforms will reveal castings so badly rusted as to be unfit for use—castings which have become obsolete and for classes of power having a small number of engines operating over several divisions, an unwarranted surplus of material for these particular classes.

The engine house presents a problem differing from the shop in that equipment must be kept in serviceable condition and yet maintain adequate power to meet traffic demands. The first essential in any terminal is the layout. Time available for necessary work is limited, and the best equipped engine house in the country is handicapped without a well arranged terminal. Everything should be subordinated to the one idea of locating outside facilities so that necessary inspection, fire-cleaning, sanding, coaling, etc., can be expeditiously completed and the engine delivered to the house with the maximum portion of layover possible available for the required repairs. In many places faults in original layout, restriction of location or available ground are such that the ideal cannot be secured, but in many cases inexpensive readjustments will often enable a closer approximation to the ideal.

Thorough attention and correction of minor defects has been often stressed in the past. The old adage, "A stitch in time saves nine" is fully applicable to terminal repairs. Repairs should be promptly made, and even though their completion may involve withholding power, the cumulative delaying effect will, in the majority of cases, be diminished by such laying in of locomotives.

Equally as important as the making of necessary repairs is the investigation and connection of cause and effect. Too often rod bushings are renewed when the fault is a pedestal shoe or wedge not properly set up or requiring lining. Valve stem packing has been frequently renewed when the fault was a bent valve rod.

And, lastly, attention must be paid to engine house and shop equipment. Small tools must be available in quantities to meet strenuous demands. Not so much fault, however, is to be found in this respect as in the matter of ma-

* See the *Railway Mechanical Engineer* for June, 1917, page 289.

† See the *Railway Mechanical Engineer* for October, 1917, page 541.

chine tool and handling equipment. Machine tools must be supplied the engine house if it is to properly and promptly return power, so that, except for heavy repairs, it shall be independent of the shop. While the practice of passing second hand machinery to the roundhouse is not to be encouraged, it is highly probable, however, that some

of the demands can be met by equipment released through centralized production or the installation of intensive production machinery. In the main, however, terminal machine tool equipment must be of a more rugged construction, simple in mechanism and with a wider range of adaptability than that suitable for back shop operation.

LOCAL STRESSES IN BOX BOLSTERS*

Tests of Loaded Bolsters with Berry Strain Gage Showing Effect on Strength of Design Details

BY L. E. ENDSLEY

Professor, Railway Mechanical Engineering, University of Pittsburgh

THE stress developed in a cast steel side frame for freight cars was discussed in a paper read by the writer before the Pittsburgh Railway Club in February, 1915.† In that paper the stress was determined at different points on the side frame by means of the Berry strain gage, and this gage was also used in the investigation of box bolster stresses.

The Berry strain gage, shown in Fig. 1, permits the elongation of a one or two-in. gage length to be determined

would be approximately 220 per cent of the normal reaction. For the purpose of these tests a car of 43,000 lb. weight with a capacity of 110,000 lb. was assumed, which gave approximately 68,500 lb. on the center plate with the car standing. Using 220 per cent of this load gives a force of 150,000 lb. on the entire bolster. In order to submit both ends of the bolster to the same stress as one would be subjected under the assumed load, the combined method of loading illustrated in Fig. 2 was used. This was done in order to get four readings on each bolster at the four equivalent points.

Bolster *H* was tested also under a center load of 68,500 lb., and bolster *I* was tested under a center load of 68,500 lb. only. This was done in order to take readings on top of the side bearings.

The results of tests on nine bolsters are included in this paper, all being of the box section and for 50-ton capacity freight cars.

It will be seen from Fig. 3 that bolster *A* has a curved bottom struck on a radius having the center on a line perpendicular to the center of the bolster, and due to the raised

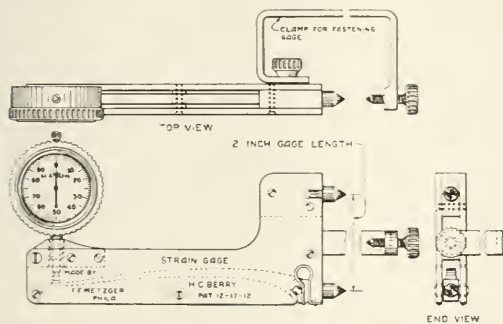

Fig. 1—Berry Strain Gage

to .0002 in. The dial of the gage is divided into 100 divisions. The movement of the hand between two of these divisions, which is approximately 1-16 in., is equivalent for cast steel to a stress of 2,700 sq. in. This was arrived at by determining the modulus of elasticity from test bars made of cast steel, which was found to be approximately 27,000,000.

METHOD OF LOADING

The method of loading for all of the bolsters tested, with the exception of one, is shown in Fig. 2. It will be seen that there are three points of applying the load, namely, on the center plate and on each side bearing. In the Pittsburgh Railway Club paper it was suggested that 220 per cent of the normal standing load would be a conservative figure to assume for the maximum direct vertical load coming on the side frame. The M. C. B. committee on Axle Design some years ago, assumed a horizontal load equal to four-tenths of the vertical load to act horizontally six feet above the rail. Assuming the center plate height to be 26 in. above the rails the maximum reaction on the truck spring for side bearing spacing of 50 in. for a 68,500 lb. static load and transverse load of four-tenths of the vertical,

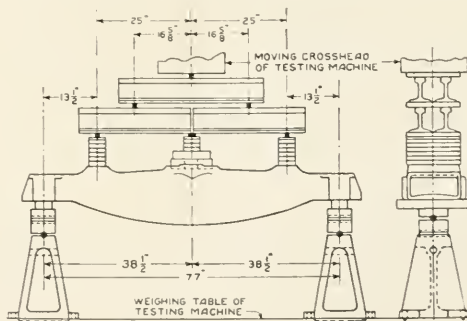

Fig. 2—Method of Combined Loading

side bearing, the metal in the top was not in a continuous straight line.

LOCAL STRESS DETERMINATIONS

Results obtained on bolster *A* are shown in Fig. 4. The numerical values given in this, as well as in all the remaining diagrams, give the stress at the points shown in pounds per sq. in. under the load shown on each diagram, which was 150,000 lb. for all tests but two. Where a minus sign appears before the number, the stress was compression. Those without this sign indicate tension. From a study of

* Abstract of a paper read before the St. Louis Railway Club, May 10, 1918.
 † See the *Railway Age Gazette, Mechanical Edition* for March, 1915, page 127.

same as bolster *E* except that the small holes at the ends had been moved in 3½ in. and holes cast in the top as shown in Fig. 10. It will be seen that the stresses around the small end holes were materially reduced, having a maxi-

top, but none in the bottom. A stress of 20,500 lb. compression was developed in the top member at a point on the edge of the bolster about 18 in. from the end, and a stress of 15,900 lb. was developed in the tension member almost directly under the point. These high stresses are due to the small depth of the bolster, which has an effective depth of only 3½ in. as compared with 7 in. for those previously

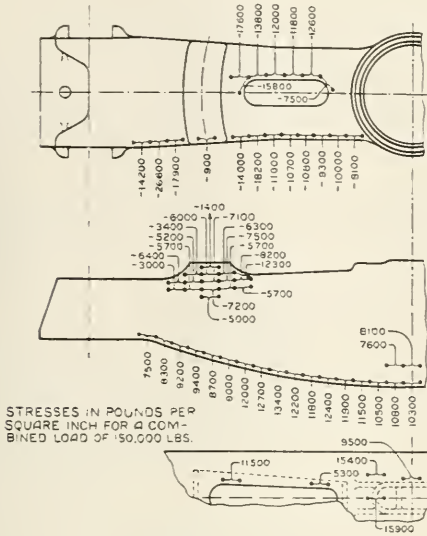

Fig. 4—Stresses in Bolster "A"

imum of 3,400 lb. The maximum stress in the compression member of this bolster was 13,700 lb. This was just outside and inside of the side bearing on top of the bolster. A stress of 13,400 lb. was obtained on the bottom of the com-

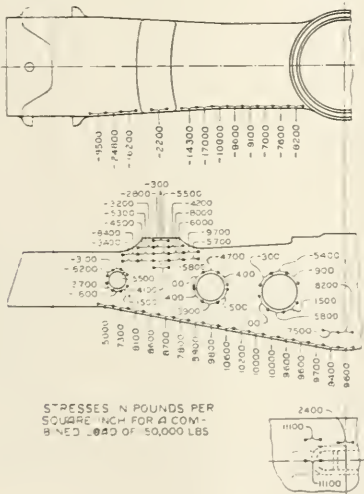

Fig. 5—Bolster "B"

pression member at the edge of the top hole, as is indicated in section *B-B*. The bottom of this bolster has a maximum stress of 10,700 lb. tension.

The design of bolster *G* and the results of its test are shown in Fig. 11. This bolster had holes in the sides and

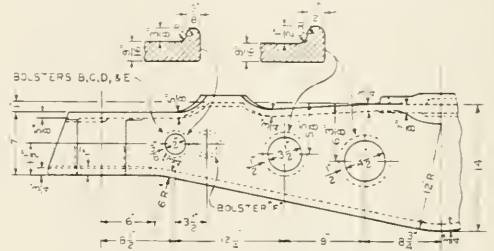

Fig. 6—Location of Holes in Sides of Bolsters "B," "C," "D," "E," and "F"

referred to. It will be seen that the stress is very small all along the tension member for a considerable distance out from the center. This bolster is 14½ in. wide, while the others were only 11 in. wide.

The results obtained on bolster *H* and the details of the design are shown in Figs. 12 and 13. The results given in Fig. 12 are for a combined loading of 150,000 lb. It will

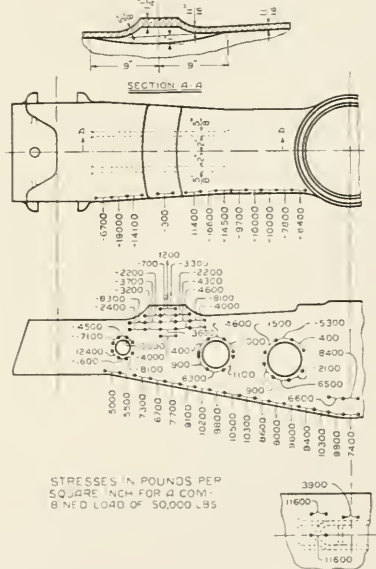

Fig. 7—Bolster "C" with Reinforced Side Bearings

be seen that the maximum compression point is at the outer end of the hole in the top of the bolster, where the stress is 19,600 lb. and that the stress is practically 19,000 lb. at the edge of the bolster along the side bearings. The tension stress is 23,000 lb. at a point just under the side bearings at the curve of the tension member. The tension stress is also high on both sides of this point.

Fig. 14 gives the results obtained on bolster *H* under a

central load of 68,500 lb., and shows some interesting results. More readings were taken under this method of load-

difference in readings at the outside and inside of the bolster at the edge of the holes. Another point where the inside and outside stresses are different is across the inner

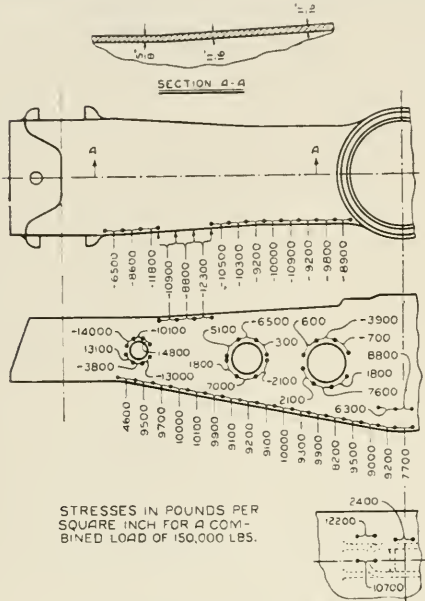

Fig. 8—Bolster "D" without Side Bearing

ing, including some on the inside of the bolster which are indicated as B readings. The half-section A-A shows the

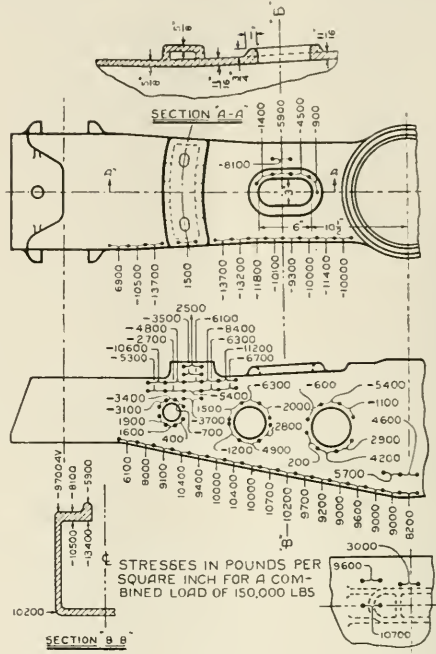

Fig. 10—Bolster "F"

edge of the hole in the tension member, where a compression of 16,200 lb. is shown on the outside and the B reading on the inside is 6,200 lb. tension, showing a strong ten-

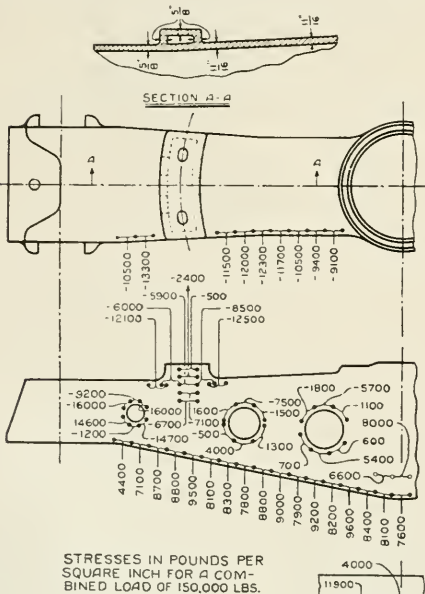

Fig. 9—Bolster "E"

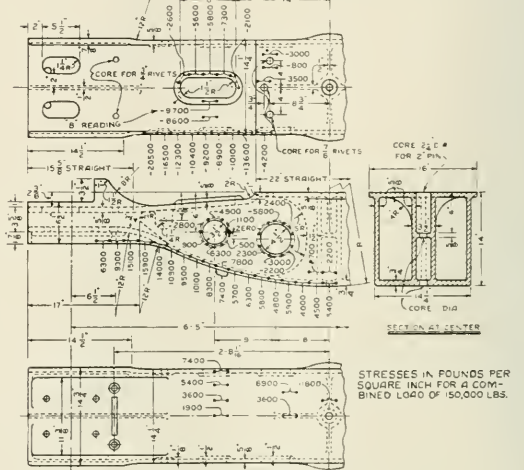

Fig. 11—Bolster "G"

dency to bend up at this point. The same thing is true at the outer end of this opening, where the stress on the outside is 11,300 lb. compression and on the inside 3,000 lb.

tension. Just the opposite tendency is true, but not to so great an extent, at the ends of the hole in the compression member.

The results obtained on bolster *I* are given in Fig. 13.

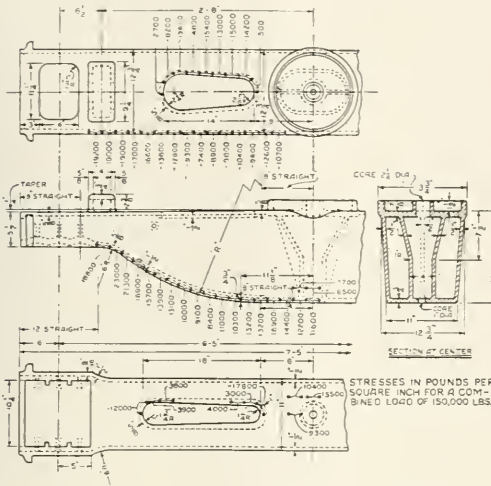

Fig. 12—Bolster "H" Under 150,000 Lb. Combined Load

outside edge. This tension is due to the side bearing bending up. The stress on the side of the bolster plotted at the left of section 2-2 shows that the compression in the side

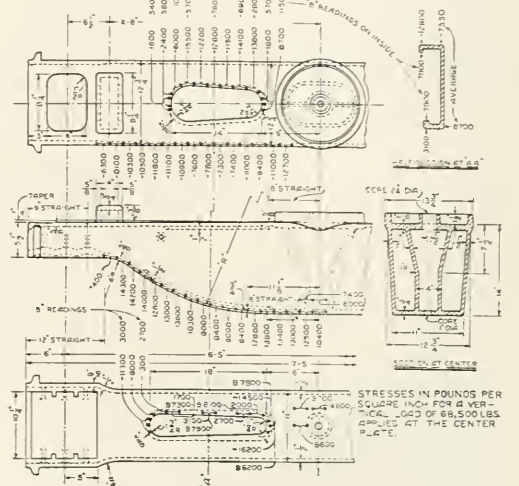

Fig. 14—Bolster "H" Under 68,500 Lb. Load at Center Plate

This bolster was only tested under a central load of 68,500 lb. The interesting thing about this test is the results obtained from readings taken on top of the side bearings.

of the bolster at the corner is a little less than 10,000 lb. Referring to the plot of the stresses in the top it will be seen that the lines in the two diagrams meet at a little less

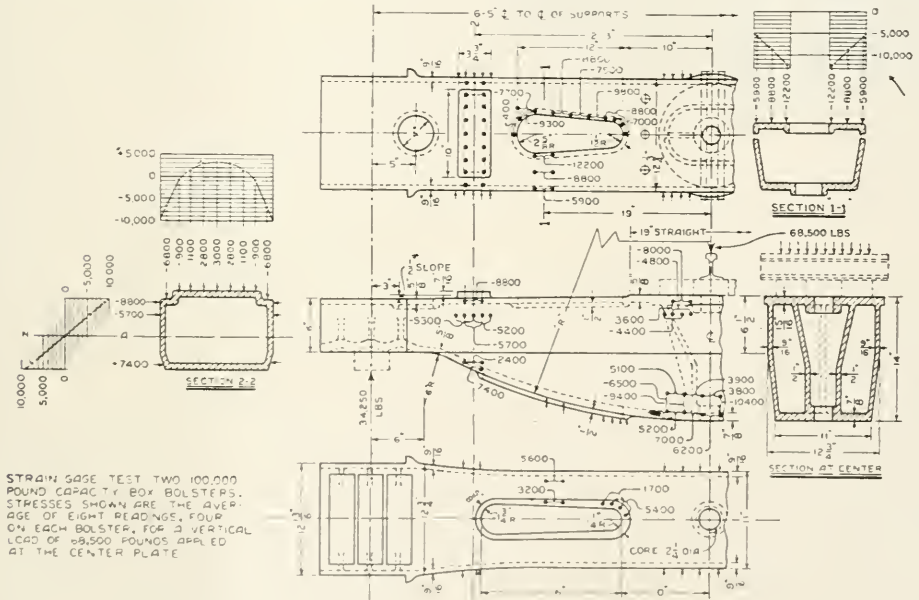

Fig. 13—Bolster "I" Under a 68,500 Lb. Load at the Center Plate

These are plotted at the left of the drawing and show that the top of the side bearing is in tension 3,000 lb. at the center, gradually reducing until compression is shown at the

than 10,000 lb. Another interesting thing about this bolster is the effect of the hole upon the stresses, which are plotted at the right above section 1-1. Here it will be seen

that the stress gradually increases at the outside edge from 5,000 lb. to a maximum of 13,000 lb. at the inner edge of the hole. In other words, this hole, because of its breadth, has a weakening effect upon the bolster. This, however, may be influenced some by the raised side bearing.

When testing a new design of bolster or side frame, I have white-washed a great many with a mixture of silica powder and water and this has helped a great deal in quickly locating weaknesses in design. While it is not an absolute check upon the Berry strain gage, it has given some very interesting facts.

Fig. 15 is a side view of bolster *E* that has been strained under a central load of 390,000 lb. There are no cracks around the side bearing on this bolster, the only cracks shown being above and below the two central holes. The end hole shows clearly, however, some shear cracks in the whitewash out from the center on the side wall. Of course this load is way above any load the bolster would ever attain, which is the reason for this scaling. This is a quick method for determining the points of maximum stress. It should not be assumed, however, that the stresses in this bolster previously referred to should check with the scaling photograph, as the latter was obtained under a central load

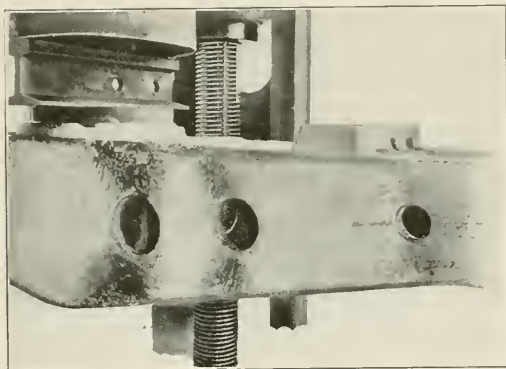

Fig. 15

only, while the results with the Berry strain gage were obtained under a load applied at three points.

CONCLUSIONS

There are a great many things to be considered in the design of a Lox bolster and some of the most important I have attempted to show in these tests. For instance, the depth at the end is an important thing and some designers of cars have not left sufficient space for this part of the bolster in laying out the car. This depth should be at least six in. Another thing which causes high stresses in some bolsters is the fact that cast steel can be made to almost any shape. The side bearings are cast on the bolster; that is, the top member of the bolster is not a straight, continuous web but is made up of several curved portions. This makes sharp corners on some bolsters and curved members on others. This is always a source of high stress. It is evident to every one that if a column—and that is really what the top of the bolster is—is made crooked, it will not be as strong as a column that is made straight. This also is true of the tension member. For maximum efficiency it should be made straight. While it often appears stronger from a comparison of the section moduli, in every case the tested straight tension member has a less maximum stress than one with a curved bottom, where the bolsters are otherwise comparable.

This brings up the question: Of what value is the old method of figuring the strength of any bolster? As long as you do not have curved tension or compression members and abrupt sections, the results obtained in a calculation of the bolster will check rather closely with the actual stress at any point. If the sections are not straight and uniform, the calculated stresses cannot be depended upon. I have found the calculated stress in some cases to be only 50 per cent of the actual stress and in other cases the calculated stress will be higher than the actual stress.

REPAIRING FOREIGN LOCOMOTIVES

THIS is the railroad shop man's opportunity to do his bit," said the superintendent of one of the shops that has been repairing a large number of foreign engines. "It not only helps the country and the road that sends its locomotives to our shop, but it helps us as well. I have had a chance to observe the practices of these other roads and to see the results they give in service. I have got some valuable pointers, and will apply what I have learned to improve our own motive power." The attitude expressed in these remarks is typical of the position taken by the men in the shops that have been called on to assume the burden of repairing engines from other roads with facilities already congested by the home equipment. This is the spirit of men who recognize that the roads are now a unit—the servants of the government—the third branch of the service which is quite as essential in winning the war as the army and the navy.

From Chicago as far west as Topeka and Parsons, Kansas, and Ogden, Utah, and as far north as Brainerd, Minn., shops will be found working on locomotives owned by roads in the eastern section where the greater part of the war industries are located and where the unprecedented traffic has worn out engines faster than the shops could repair them.

The repairing of locomotives in shops of foreign lines was put into practice when the roads were taken over by the government. The regional directors secured information concerning the possible increases in the production of shops which were not working to full capacity, and early in the year the first locomotives were distributed among shops in the Middle West.

Careful preparations were made for furnishing everything that would be required in working on locomotives from foreign lines. Complete sets of blue prints and details of standard practices were sent with each engine. All parts were carefully inspected before the locomotives were shipped, and if this inspection disclosed that material would be required which the repairing road was not apt to have in stock, it was sent to the shop, either in the tender or in a separate car accompanying the locomotive. That the precautions were effective in facilitating the work is indicated by the comment of a foreman who remarked that he found little difference between working on foreign engines and on those of his own road.

When the locomotives were shipped they were usually given a thorough inspection by an inspector from the owning road, who accompanied the engine to the shop, and by the foreman of the road doing the work. At this inspection it was definitely decided what repairs were to be made, and if it was found that any additional material would have to be secured from the owner by ordering it at once the progress of the work as a rule was not delayed.

It is usually necessary to furnish a considerable number of small parts, such as grease cups, plugs and bushings, cylinder cocks, etc. Such material should always be sent finished, except in cases where each part must be fitted individually. These parts are usually produced in quantities, and each road has special facilities for making its own standard equipment. Where rough castings are sent to the road which is to repair

the locomotive, a great deal of time is wasted in finishing the parts.

In spite of all that could be done, it has been found that the most serious hindrance to the work was caused by delays in securing material. For instance, one locomotive in a foreign shop was found to have the tires out of gage. When the tire was heated in order that it might be reset, the wheel center was found to be cracked beyond repair. The defect could not be detected until the tire was loosened and several weeks elapsed before a new casting could be secured.

Next to the difficulty of obtaining material, the most serious embarrassment was caused by the variation in standards on different roads. There is a lack of uniformity in the amount of taper used on fitted bolts. If a hole is reamed with a reamer having either greater or less taper than that originally used, the diameter must be increased considerably to secure a bearing for the full length on long bolts. To avoid enlarging the holes unduly, it was necessary in some cases to send with the locomotive a set of reamers having the proper taper. The situation with regard to boiler screw threads was quite similar. Some roads used the V-thread and others the

United States standard thread, and the amount of taper varies considerably.

The instructions issued by the owning road specifying the work to be done and the standard practices to be followed, were helpful in many cases, but in some instances they resulted in work being done which was quite unnecessary. Often the instructions called for the renewal of parts which had not been inspected before the locomotive was shipped, and in some cases it was found that the wear on these parts was so slight that they would have remained in service until the next shopping with minor repairs. Such conditions could be avoided by giving more authority to the inspector representing the owning company. These men who were chosen to oversee the work have had wide experience, and their judgment should be relied on. Furthermore, the foremen of the shops repairing locomotives from foreign lines are too jealous of their good name to allow a locomotive to go from the shop to another road in any but the best of condition. To place unnecessary restrictions on the methods of overhauling power indicates a lack of appreciation of the service which the roads taking in locomotives from foreign lines are rendering.

LARGE APPROPRIATIONS FOR SHOPS

The Railroad Administration Allows Liberal Expenditures for Improving Railway Mechanical Facilities

THE expenditures for improvements to railway facilities approved by the Railroad Administration through the Division of Capital Expenditures and made public on May 18, involve an amount chargeable to capital account of \$937,961,318, of which \$440,071,013 is for additions and betterments, \$479,686,531 for equipment and \$18,203,774 is for extensions. A detail study of the budgets of fifty of the more important lines, having an aggregate mileage of 151,494, shows that a particularly generous amount has been granted for improving the mechanical facilities and equipment. A summary of the expenditures granted these roads chargeable to both capital and operating accounts for these items is given in the table. About \$65,000,000 has been approved for shop buildings, engine houses, etc.; for shop machinery and tools \$9,248,249 has been appropriated and for improvements to existing equipment \$33,132,313 has been granted. The amounts for shop buildings, etc., include expenditures to be made for additions to existing buildings, new shops and enginehouses, and the shop machinery and tools required for these new shops. It will thus be seen that considerable more than that shown under the heading of shop machinery and tools will be spent for these items.

It has been the disposition of the Railroad Administration in the consideration of the budgets, to grant those expenditures which will materially increase the capacity of the railroads. It has been known for a long time that the mechanical facilities for handling cars and locomotives have been deficient and for that reason particularly liberal amounts have been granted for this purpose. Fuel stations, water stations, etc., are other items which have been given particular attention, about \$10,000,000 being appropriated for this purpose on the fifty roads shown in the table. Approvals for projects which might be considered unessential to winning the war have been made to cover, particularly on work that has already been started, amounts necessary to permit a cessation of the work without loss to the company. The following is a summary of the important work to be done on various railroads in improving the facilities for repairing and handling cars and locomotives.

IMPORTANT MECHANICAL FACILITIES AUTHORIZED

A large expenditure is to be made on the Baltimore and Ohio for shop buildings, enginehouses, etc. The largest single item in this account is the shop and enginehouse at Glenwood, Pa., just outside of Pittsburgh. This shop will have a capacity of 40 to 50 locomotives per month. Over \$1,300,000 has been appropriated for the shop and enginehouse at Cumberland, Md., and a new shop and enginehouse will be built at Youngstown, Ohio, at a cost of \$740,000; an extension will be built to the shop and enginehouse at Washington, Ind., for \$272,730; an enginehouse will be built at Grafton, W. Va., at a cost of \$328,086, and the shop and enginehouse at Dayton, Ohio, will be rebuilt at a cost of \$225,000.

A particularly large amount, \$3,407,221, has been given the Boston & Maine for shop buildings, enginehouses, etc. This includes an enginehouse at Concord, N. H., costing \$800,000; one at East Deerfield, Mass., costing \$770,000; one at Lowell, Mass., costing \$750,000; one at Dover, N. H., costing \$275,000, and one at East Cambridge, Mass., costing \$143,500.

The Chicago, Burlington & Quincy will build an engine terminal costing \$155,000 at Eola, Ill.

The Chicago, Milwaukee & St. Paul was allowed an expenditure of \$680,000 for the engine terminal at Savanna, Ill.; \$601,870 for an engine terminal at Ottumwa Junction, Iowa, and \$236,000 for a freight and engine terminal at Atkins.

The Rock Island was granted nearly \$1,000,000 for shop buildings, enginehouses, etc., which includes improvements at Herington, Kan.; Amarillo, Tex.; Manly, Iowa, and Burr Oak, Ill. Over \$1,000,000 will be spent for second track on this road.

The Cleveland, Cincinnati, Chicago & St. Louis has received \$710,419 for shop buildings which includes engine terminals at Galion, Ohio; Sheff, Ind., and additions at various points.

A large amount has been given the Erie for shop buildings, enginehouses, etc.,—\$2,382,156. This expenditure includes a 31-stall enginehouse and engine terminal facilities

at Meadville, Pa., at an estimated cost of \$411,191. New engine terminals will be built at Girard, Ohio, for \$400,000, and at Avoca, East Buffalo and Dayton, N. Y. A scrap reclaiming plant will be built at Meadville at a cost of \$95,000.

The Grand Trunk has an appropriation of \$1,058,609 for shop buildings, enginehouses, etc., which includes a 15-stall roundhouse at Pontiac, Mich., and improvements at West Bethel, Me.; Battle Creek, Mich., and Fort Gratiot.

The mechanical facilities of the Hocking Valley at various points throughout the system will be improved, \$409,296 being appropriated for this purpose.

The Illinois Central was given \$2,345,170 for shop buildings, enginehouses, etc., which will be used to improve the mechanical facilities at Kankakee, Ill.; Clinton, Ill.; Mattoon, Ill.; Freeport, Ill.; Waterloo, Iowa; Jackson, Tenn.; McComb, Miss.; Champaign, Ill.; DuQuoin, Ill.; Benton, Ill.; Carbondale, Ill.; Mounds, Ill.; Amboy, Ill.; Fulton, Ky.; Paducah, Ky., and Central City, Ill.

The Lake Erie & Western has been given over \$800,000 for shop buildings and enginehouses, of which \$500,000 will be for a locomotive repair shop at Tipton, Ind.; \$158,200 for rebuilding the enginehouse at Lima, Ohio, and \$79,200 for rebuilding the enginehouse at Peru, Ind.

The largest item of expense in the budget of the Lehigh Valley is for \$2,514,114 to be spent for shop buildings, enginehouses, etc. A new engine terminal is to be built at Hazleton, Pa., at an estimated cost of \$1,000,000 and a new engine terminal will be built at Jersey City at a total cost of \$1,400,000, of which \$900,000 has been appropriated for 1918.

The Michigan Central will make an expenditure of \$2,231,080 for shop buildings, enginehouses, etc., which includes new engine terminals at Jackson, Mich., and Michigan City, Ind. Additional shop facilities will be provided at a cost of \$335,000, and a new steel car repair shop will be built at West Detroit at a cost of \$210,000.

One of the largest individual items for the New York Central is \$7,707,600 for shop buildings, enginehouses, etc. This includes a car repair shop at Avis, Pa., for \$746,000; new engine terminal facilities at Watertown, N. Y., for \$700,000; a new enginehouse at Syracuse, N. Y., for \$540,000; additions to the car repair shops at East Buffalo for \$520,000; an addition to the erecting shop at Collinwood, Ohio, for \$345,000; a new enginehouse at Genesee, N. Y., for \$200,000; a car repair shop at New Durham, N. J., for \$198,000; a new enginehouse at DeWitt, N. Y., and additions to the enginehouses at Norwood, N. Y.; Clearfield, Pa., and Cherry Tree, Pa.

The shops and enginehouses on the New Haven will be improved generally for handling heavy power, particularly the Santa Fe type locomotives which that road has received. Fifteen stalls will be added to the enginehouse at East Hartford, 10 stalls to the Medway enginehouse on the New London division and seven stalls to the Waterbury (Conn.) enginehouse.

The Norfolk & Western will spend \$879,000 for the Roanoke (Va.) yards; \$590,000 for the Hagerstown (Md.) yards and \$565,000 for improvements in the Bristol (Va.) yards. In addition to this an additional new shop building will be constructed at Roanoke at a cost of \$575,000 and \$222,634 has been appropriated for the shop building at Shenandoah, Va., which is under way.

The principal feature of the Northern Pacific budget is a new car and locomotive shop at Mandan, N. D., towards which \$500,000 has been appropriated. A new car repair shop will be built in the Como yards near St. Paul at a cost of \$250,000.

The expenditure of \$4,609,108 for shop buildings, enginehouses, etc., on the Philadelphia & Reading will include new engine terminal facilities at Reading, Pa., costing \$355,000;

a new addition to the enginehouse at St. Clair, Pa., costing \$92,000; a new extension to the shops at Reading, costing \$255,000; a new engine terminal at Tamaqua, Pa., costing \$200,000; new engine facilities at Chester, Pa., \$140,000; new engine facilities at Coatesville, Pa., costing \$440,000; a new enginehouse and machine shop at Rutherford, Pa., costing \$145,000, and \$157,172 for engine facilities at Reading, which are 49 per cent completed.

With about \$700,000 for shops the St. Louis & San Francisco will improve mechanical facilities at a large number of its repair points.

The Union Pacific will spend over \$6,000,000 on terminal improvements, divided as follows: Cheyenne, Wyo., \$1,689,425; Council Bluffs, Iowa, \$1,647,351; Junction City, Kans., \$1,175,007; Green River, Wyo., \$919,674; Omaha, Neb., \$535,026; Sidney, Neb., \$158,935; Grand

EXPENDITURES FOR ADDITIONS AND BETTERMENTS TO MECHANICAL FACILITIES

Road	Shop buildings, enginehouses, etc.	Shop machinery and tools	Improvements to existing equipment
Ala. Grt. So.	4,000		
Arch. Top. & Santa Fe	712,365	468,973	
A. C. & O.	101,648		430,667
Balt. & Ohio	5,981,950	645,270	1,626,373
Bos. & Albany	47,900		
Bos. & Maine	3,497,221	22,914	2,633,692
B. R. & P.	779,959	197,960	313,649
Central of Ga.	143,599	3,749	167,000
Central of N. J.	300,400		
Ches. & Ohio	780,513	368,050	423,921
Chic. & Alton	185,000		65,624
C. & E. I.	181,367		954,061
C. & N. W.	1,119,063	199,126	
C. R. & O.	331,671		350,778
C. M. & St. P.	1,969,370	448,200	1,230,184
C. R. I. & P.	945,627	354,266	1,810,475
C. N. O. & T. P.	30,000	6,500	
C. C. & St. L.	710,419	707,750	996,838
Cumb. Valley	742	488	
D. & H.	90,307	30,304	732,168
D. L. & W.	308,102	24,775	419,369
D. M. & N.	186,155		16,500
Erie	2,382,136		677,793
Grand Trunk	1,058,609	128,314	20,391
Great Nor.	539,000		432,531
G. C. & S. F.	109,923	17,106	6,855
G. H. & S. A.	3,110	3,110	66,305
Hocking Val.	490,296	106,756	351,522
Ill. Central	2,345,170	537,932	1,471,823
K. C. & S.	17,420	97,347	1,217,447
K. C. & Term.		41,130	4,300
L. E. & W.	800,500	20,200	73,840
Lehigh Val.	2,514,114	230,538	669,472
Long Island	92,349	57,753	137,252
Mahoning Coal	787,400		
Mich. Central	2,231,080	192,098	443,035
M. St. P. & S. S. M.	110,650	33,675	186,770
N. C. & St. L.	357,363	56,000	151,067
N. C.	7,707,600	623,800	6,313,317
N. Y. & N. H. & H.	1,486,389	469,974	1,793,306
N. & W.	1,082,630	275,000	1,261,301
Nor. Pac.	950,000	120,000	1,116,170
Pa. & West.	7,464,754	459,960	1,187,102
Pa. East.	3,780,466		1,250,000
Phila. & Read.	4,609,108		
S. L. & S. F.	699,150	207,141	1,139,944
Southern	182,696	45,000	
St. P. & Pac.	608,964	73,355	507,662
Union Pac. System	41,134	448,475	343,898
U. P. Term. Improvements	3,811,000	835,040	
Y. & M. V.	175,471	43,020	16,513
Total	64,732,478	9,248,249	33,132,313

* Amounts for all items were not available.

Island, Neb., \$43,100; North Platte, Neb., \$25,200; Ellis, Kans., \$9,000. At Cheyenne a machine shop will be built costing \$1,276,500. At Council Bluffs \$440,000 will be expended for a 40-stall enginehouse, \$293,000 for a power house, \$235,000 for a machine, boiler and blacksmith shop and \$175,000 for a 600-ton coaling station. At Junction City a machine, boiler and smith shop will be built at a cost of \$270,000, a 20-stall enginehouse at a cost of \$240,000 and a 400-ton coaling station at a cost of \$110,000. The improvements at Green River include a 28-stall enginehouse costing \$280,000, a machine, boiler and smith shop costing \$235,000, a car repair shop costing \$85,000 and a storehouse costing \$68,000. At Omaha, Neb., an extension to the machine shop will be built at a cost of \$245,000. Over \$800,000 will be spent for machine tools for the various shops in this program.



THE FUEL ASSOCIATION CONVENTION

A Wartime Meeting Conducted Under the Auspices
of the Federal Railroad and Fuel Administrations

THE tenth annual convention of the International Railway Fuel Association, which was held at Chicago, on Thursday and Friday, May 23 and 24, 1918, differed materially from all previous meetings of the association.

The arrangements for the convention were made under the direction of the Railroad and Fuel Administrations, and the meetings were notable for the absence of all technical discussion of specific questions of railroad fuel supply and economy. The entire time of the convention was devoted to a broad consideration of the nation's war time fuel problem. Practically every railroad company in the country designated representatives to attend the convention and there were also present a large number of coal operators and other representatives of the mining industry.

Several changes were made in the list of speakers as announced in the tentative program published last month. C. R. Gray, director of the Division of Transportation, United States Railroad Administration, was unable to be present, and R. H. Ashton, director Western Regional District, United States Railroad Administration, addressed the meeting in his stead. Sir George Bury, chairman of the Canadian Railway War Board, was also unable to attend but was represented by Thomas Britt, general fuel agent of the Canadian Pacific Railway. United States Fuel Administrator, H. A. Garfield, and Warren S. Stone, grand chief of the Brotherhood of Locomotive Engineers, also found it impossible to be present at the convention.

The convention was opened with an introductory address by the president of the association, E. W. Pratt, assistant superintendent motive power and machinery, Chicago and Northwestern. An abstract of Mr. Pratt's address follows:

PRESIDENT PRATT'S ADDRESS

There are three items in this tremendous fuel problem—production, transportation and consumption—and the railroads of this country are largely responsible for all three of them; for production in so far as concerns the delivery of

machinery and supplies to the mines and a car supply for the coal produced.

The next item is transportation. Railroad men are a hardy and earnest lot and not easily discouraged, working every day in the year, including Sundays and holidays. But when last winter, after weeks of continued and unprecedented snow and cold, their locomotives were compelled to operate with added disadvantages of poor and dirty coal it was perhaps the greatest obstacle of all and many a locomotive died and its train was abandoned for this reason. I have yet to see a miner or operator who would defer to the railroad man in the matter of patriotism or loyalty to country, and I believe if the proposition is put squarely up to the men that there will be no Sundays or holidays in either the mine, on the railroad or in the coal yard when it concerns the output and distribution of coal, any more than there is Sunday or holiday in the trenches with the Hun facing our boys and the Kaiser menacing our free institutions.

The 27 per cent of the coal produced which is used by the railroads is so large that we hope by care and close attention to details not only as to firing but in better repair of locomotives, more care in despatching and moving trains, and better operation on the part of the engineer, to save millions of tons of coal and millions of gallons of fuel oil. Superheating has been proven practicable and each locomotive so equipped saves hundreds of tons of fuel per year besides rendering faster and better service; hence, the present practice of superheating the larger locomotives passing through the shop should be continued as far as possible, considering the scarcity of materials and skilled labor to apply them. The locomotive feed-water heater also offers an attractive field for economy and efficiency and well warrants careful and continued experimentation.

"The Railroad Industrial Army," was the subject of a paper by W. S. Carter, director of the division of labor of the Railroad Administration. An abstract of this paper, which dealt with the conditions demanding extraordinary

effort and increased productiveness from every railroad man, will be found on page 314 in this issue.

RELATION OF LOCOMOTIVE MAINTENANCE TO FUEL ECONOMY

BY FRANK McNAMANY

Manager Locomotive Section, United States Railroad Administration

Fuel economy and locomotive maintenance in practically everything that relates to efficient locomotive performance, are synonymous terms. Within recent years the increasing cost and scarcity of fuel have made fuel economy a question of major importance to the designer of locomotives as well as to the officials in charge of locomotive maintenance. The inventor has also turned his talents in that direction, with the result that the superheater, the brick arch, the combustion chamber firebox, and other fuel saving devices, are today parts of the equipment of every modern locomotive. The influence of these devices in effecting real fuel economy is tremendous, and their application to many existing locomotives will result in a marked reduction in fuel consumption.

The boiler, to promote economy of fuel, must be properly designed, with ample grate and heating surface. It must be clean, the grates level and easily shaken and in good condition, the ash pan and grates must have ample air openings to aid combustion, the firedoor should operate easily, and the fire tools should be in good condition. The flues must be clean, the flues and firebox free from leaks, smokebox must be air tight, the smoke stack and nozzle in line, and the draft appliances in good condition and properly adjusted.

Too much stress cannot be laid on the necessity for keeping boilers clean, because in addition to effecting a material saving in fuel, it increases the efficiency of the locomotive and materially prolongs the life of the flues and firebox sheets. Frequent and thorough boiler washing is the foundation of proper boiler maintenance. Authorities differ somewhat as to the exact loss due to scale on boiler sheets but a comparison of tests made indicate pretty conclusively that 1-16 in. of scale will increase the fuel cost approximately 15 per cent and that $\frac{1}{4}$ in. of scale will increase the fuel cost approximately 60 per cent.

It is not an exaggeration to say that on an average 40 per cent of the locomotive boilers in service have scale 1-16 in. thick or to say it differently, that due to poor boiler washing all of them have 1-16 in. scale 40 per cent of the time, and that many have scale from $\frac{1}{8}$ in. to $\frac{1}{4}$ in. in thickness. In fact in some districts it is not unusual to find $\frac{1}{2}$ in. of scale on boiler sheets. Let us see what this means in actual figures. In 1918 it is estimated that the railroads will require 166,000,000 tons of coal at an average cost of \$3.50 per ton, which will be a total of \$581,000,000. If we add to this 48,000,000 barrels of fuel oil it will make the total fuel cost over \$650,000,000. We will pay, therefore, during the year of 1918 more than \$50,000,000 for fuel on account of the scale in locomotive boilers that many men do not consider of sufficient importance to warrant its removal.

But even a boiler that is clean and in the best of condition can do no more than generate steam; proper steam distribution to and from the cylinders must be had and the steam made to do effective work. If the valves are out of square or blowing or the valve gear badly worn; if valve chambers or cylinders are badly worn or out of round; if the cylinder packing is worn or broken; if leaking piston rod packing or leaks about the steam chests or cylinders dissipate the steam that should and could be made to do work, we can expect no improvement in our fuel performance.

Assuming, however, that the boiler is in good condition, that the steam distribution is good, and that there is no waste of steam through steam leaks, it remains to deliver this power at the drawbar, and this cannot be efficiently or economically

done through the medium of worn-out machinery. Rods in bad condition, boxes loose on journals, wedges which require adjusting, and tires badly worn which will cause excessive slipping, are poor mediums through which to transmit energy.

Some of the repairs which will do the most towards reducing the fuel consumption and improving locomotive performance arranged in what is believed to be the relative order of their importance, are, setting the valves properly and maintaining the valve motion, washing the boilers, keeping the tubes clean, eliminating steam leaks about the cylinders and the steam chests and maintaining the driving boxes and rods.

If it were possible to calculate the aggregate loss in operating efficiency for the total number of locomotives due to lack of maintenance or operating at less than their maximum efficiency, the result would be staggering, and when we add to this enormous loss of operating efficiency, from 10 to 20 per cent of the railroad fuel bill which for the past year was \$329,000,000, and for the current year is estimated to be \$581,000,000 for bituminous coal alone, we begin to realize the price we have been paying for the privilege of operating defective locomotives and delaying traffic thereby. This being true, the question that must inevitably follow is, what is being done by the U. S. Railroad Administration to remedy the conditions which have been described.

The first step before taking action to bring about an improvement in the condition of locomotives was to make a survey of the field. The next step was to speed up locomotive repairs to provide motive power to meet the immediate needs and this was done by increasing the shop hours about 16 per cent for over 200,000 men, and by nationalizing locomotive repairs so that a locomotive in need of repairs would be sent to the nearest available repair shop, thus utilizing to the fullest extent the total shop capacity of all railroads. The result of this soon became apparent in the increased number of locomotives turned out of the various shops which for the four months ended April 30, increased 6,849 over the corresponding period for last year. This not only means more locomotives but it means better locomotives, which both increases operating efficiency and decreases fuel consumption.

For the future the work that has been started will be continued and a higher standard of condition of locomotives required. A regular schedule for the application of superheaters and other fuel saving appliances to locomotives not now equipped, is being prepared and will be adopted subject only to labor and material being available.

Today, with the increased demands for fuel by reason of the war and the necessity for furnishing fuel to our allies; with the increased use of fuel in industries whose output is essential to the successful conduct of the war, the saving of fuel by better locomotive maintenance and the increased operating efficiency which will result therefrom, means more than can be expressed in terms of tons, gallons or dollars. It means the saving of America, the saving of Democracy, the winning of the war.

THE MOTIVE POWER DEPARTMENT AND FUEL ECONOMY

BY ROBERT QUAYLE

General Superintendent Motive Power and Car Department,
Chicago & North Western

In 1917 the railroads of this country consumed approximately 175,000,000 tons of coal. This, at an average price of \$2.50 a ton, would give us a cost of \$437,500,000. Now I maintain that if every individual in the operating end of the railway organization of this country were to work together as one man, each helping the other to the one end of

saving fuel, we could easily save 10 per cent, which would be 17,500,000 tons equivalent to \$43,750,000.

I want, first, to call attention to the master mechanic's part in this game of saving fuel. He should be in touch with the division superintendent and train dispatchers in such a way as to make them feel and really know that he is interested in them personally. It is the master mechanic's duty to be so in touch with his shop men and engineers and firemen that they will have confidence in him, and he should have the happy faculty of having the men constantly feel kindly toward him. This would enable him to get the best from the men that can be had.

He should fix the machines that the men are going to handle, so that the men will have the least amount of discouragement in their work, and there will be the least amount of effort on their part necessary to get the best results. To this end he should have his men trained to make proper reports of necessary work to be done. Occasional meetings with the roundhouse foremen, particularly calling attention to these things, and insisting upon their having the work done that is reported, will bring about good results. The engineers will take much more interest in making the detailed reports than if their reports are not given proper attention.

My next thought is the traveling engineer. What are his

fellow not only to do his bit, but to do his all, that fuel will be conserved. Fuel is now playing and will play a most important part in our warfare.

You will observe that what I have said can be summed up in a word, co-operation, and I am sure when we of the motive power department will have done our part that the men at the other end of the operating department will say to us, "You have done well." We all respond to success, and when the men in one department have shown a great improvement the other fellows will not only follow in the wake, but they will try to beat them out in the end if they can.

TRAIN LINE LEAKS AND THE COAL PILE

In a paper entitled "The Transportation Department and Fuel Economy," E. H. De Groot, Jr., assistant manager, car service section, United States Railroad Administration, drew attention to the part that superintendents, train masters, yardmasters, dispatchers, trainmen and the station forces should play in a general campaign of fuel economy. Referring particularly to the possibilities for effective work on the part of train men, Mr. De Groot said:

"The air compressor on the modern locomotive is a powerful engine. It performs wonders which are little enough appreciated by most of us but it has a frightful appetite

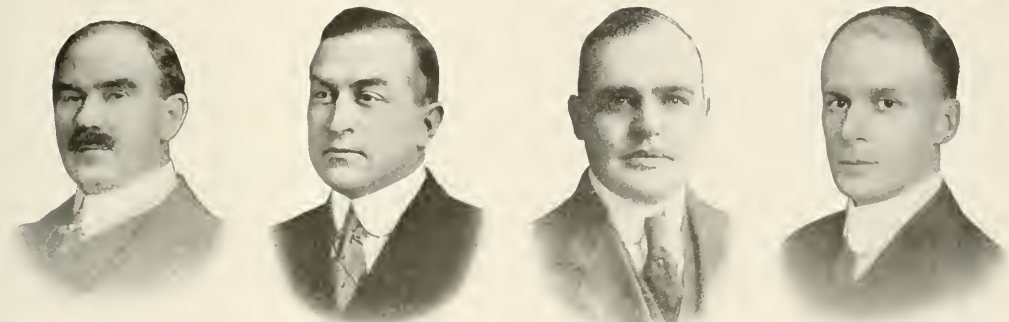

E. W. Pratt (C. & N. W.) President L. R. Pyle (M. St. P. & S. S. M.) Vice-President
 W. L. Robinson Vice-President J. G. Crawford (C. B. & Q.) Secretary-Treasurer

duties? To make inspection of locomotives; see that they are in proper condition to do the best work. He should know the condition of every engine in his charge. He should know what they are capable of doing. He should see to it, at the roundhouse end, that the engines leave fully capable of making the trip successfully and economically. He should always have it in mind that his job is one of helpfulness and instruction rather than one of fault finding and improper criticism.

The roundhouse foreman, as a rule, is the most abused man on a railway. He is up against all kinds of conditions, all kinds of problems to work out, in order that everything may move smoothly and every man be kept one at peace with the other. We require a good deal of the roundhouse foreman, and to get the very best out of his job he should be gracious, he must needs be a philosopher, he must be a student of human nature and he must smile even when everything goes "dead wrong."

Locomotive engineers and firemen, what a magnificent opportunity you men have to show your patriotism by your work! On the basis of your loyalty and faithfulness I am asking you to redouble your efforts; increase your intelligence not only for yourselves, but strongly urge every other

for steam—and steam means coal. Its cylinders are large, and as its load increases directly with the progress of the piston, the steam cannot be used expansively but must be admitted to the very end of the stroke. Under these circumstances, air leaks constitute a direct drain upon the boiler and so reach their greedy fingers back through the firebox into the precious coal pile. There is no way in which the trainman can contribute so much toward the good cause of saving coal as by stopping the train-line leaks before starting on the trip. With porous hose, worn gaskets, pipe and other leaks, what the pump has to overcome needs no description among practical men.

"Leaks are crimes when coal is a military necessity! To stop leaks then is of the greatest importance and this should be done carefully and conscientiously. Surely, any man who does less than he can, does less than he ought in this. The practice of carrying a hose-gasket or two in the pocket as some trainmen do for this purpose is an excellent one. Rainy weather offers an opportunity to locate hose which are porous to a serious extent and by changing them when opportunity offers much fuel may be saved which would otherwise be wasted.

But all of the leaks are not discoverable while the train

is at rest, particularly in cold weather, and new ones develop during the trip. These should all receive first-aid treatment as soon as found. Then, too, the leaks may result in sticking brakes and this condition is like compounding a felony. It not only takes much coal to pump against the leaks but much more coal at the same time to pull against the brakes."

THE RAILROADS AND THEIR RELATION TO THE FUEL PROBLEM

BY R. H. AIGHTON

Regional Director, Western District, United States Railroad Administration

I was appointed Western regional director last January, just about the time that we were in the thick of the fuel problem. I never want to go through such an experience again; and neither do the railroad men. There were times when there was not four hours' fuel in this city. If, by any effort of mine, and any effort of yours, we can prevent that thing occurring again, let's do it. Unless we do it, the coming winter is going to be much worse than last winter.

Suppose that we get the same enthusiasm on this fuel question, the same patriotic impulse on the part of every man in the vast army of two million railroad men in this country, that was shown in the Liberty Loan drive. There would not be any fuel famine; there would be no difficulty. There would not be any railroad problem if we would just do that. If we save one scoop of coal an hour on each locomotive it will save 765,000 tons of coal, or 17,000 carloads a year. Does any man in this audience believe that he cannot do that?

There is scarcely a man on a railroad that does not have some relation to coal saving. Take the man in the shop. The intelligence put into the work and its inspection has an immediate effect on the amount of coal a locomotive burns. The car man can have an immediate effect on coal consumption in the care of journals and lubrication. The train dispatcher, with a little more energy and forethought in ordering his trains over the road, can save just as much as the fireman. The agent at the country station may keep a train waiting two or three minutes. The enginemen have to burn coal generously to make up the time lost through the agent's carelessness.

All of us—railroad men, consumers and everyone who has anything to do with this movement—must get into the attitude expressed in Order No. 8 issued by Director General McAdoo on February 21.

SUGGESTIONS FOR SAVING COAL

BY THOMAS BRITT

General Fuel Agent, Canadian Pacific

To say that good engineering is an essential element in the process of conserving fuel is to mention a basic principle. Our locomotive and boiler-house firemen cannot be too well instructed on this point; with them, in the final analysis, rests the successful issue of our present campaign. Mechanical devices such as superheaters, automatic fire doors, etc., may accomplish a great deal in avoiding unnecessary wastage, but certainly the human element is the dominant factor—we cannot get away from it. Our firemen are as loyal as any group in the service, but quite frequently they fail to grasp the seriousness of the situation that confronts us, as well as the importance of the occupation which is theirs.

Another tangible means of saving coal to win the war is to substitute wherever possible, utilizing gas-house coke for heating stations, etc. A considerable amount of scrap wood can be utilized as fuel in shop boilers; old ties can be gathered up and burned for the same purpose.

I might more earnestly ask in exchange for our share in this worthy enterprise that our railroads be not overburdened any longer with a lot of foreign matter under the guise of

coal. I have found it necessary to have whole carloads of this extraneous matter dumped into the ditch, it being absolutely worthless as fuel for any purpose. The situation is much worse if such matter finds its way into ships' bunkers—transports especially—for then the lives of thousands are placed in needless jeopardy.

The overloading of tenders has been the cause in the past of an incalculable waste. Thousands of tons have been lost by scattering coal along the highway. Measures have been taken to avoid this frightful deficit. Ashpits also are frequently a source of wastage.

Looking at the question in a broad way, is it not quite evident that we are just beginning to wake up to the necessity of economy? The pinch of want together with the soaring of prices are making us all realize that our only salvation lies in saving.

THE NEED FOR FUEL CONSERVATION

BY P. B. NOYES

Director, Bureau of Conservation, United States Fuel Administration

The coal supply is short. Last winter it was short and the immense new requirements for war purposes threaten to make it shorter still next winter. The data we have compiled show that 625,000,000 tons of bituminous coal will be needed this year. The mines which must get out the coal, and the railroads which must carry it, were pressed nearly to their limit before the war. They cannot take on 200,000,000 tons of additional production. Fix your minds on what you know of the burdened condition of the leading railways three years ago. Add to this the tremendous burden of war supplies, troop transportation, material for ship building, and food for our Allies, and then picture to yourself what it means to those same railways with facilities little if any greater than three years ago, to provide transportation for 200,000,000 additional tons of coal. Conceive of this increase as 16 solid trains of gondola cars filling 16 tracks from New York to San Francisco. A veritable freight yard filled with coal cars extending the breadth of this continent. And this represents only the *increase* of coal transportation demanded of the railroads. All of those four million cars must be switched in and out and carried hundreds of miles by our already burdened transportation system if war demands are to be met and the usual industrial life of the country be at all preserved.

The coal business is in physical proportions so far beyond any other business in the country that emergency remedies which can be successfully applied to any of the others will hardly make a dent in the coal shortage. To meet the demands this year 12,500,000 tons of bituminous coal must be hauled every week. And yet, the success of the war is likely to depend just on this supply of coal. As much coal as was mined last year will be needed this year for war purposes alone. We must save 65 or 70 million tons or go to the restriction of so-called non-essential industries.

There has been much talk of shutting down non-essential industries but a little investigation shows that only a short distance down this road lies financial ruin and unemployment of labor on a scale which would bring disaster at home and failure in war. At least twenty billion dollars of capital is invested in legitimate manufacturing enterprises producing goods not strictly needed for the war. Ten million men support their families from the work they do in these factories. Granted that we must have 100 per cent fuel for munitions and ships, we shall fail as a nation if we do not provide this without a complete breakdown of our whole industrial system.

Fuel is a small part of the raw material of most manufacturing institutions. The fuel expense in most highly organized industries is little over one per cent of the total cost of the goods. On the other hand, this one per cent is absolutely

vital. Without it the factory closes. The other 99 per cent are useless. We are called upon to view a ton of coal as equal to five or six hundred pounds of ship plates or shells, but every ton of coal saved for our factories means the employment or non-employment of a hundred men.

This is the new idea I wish to bring you today. That over and beyond the desperate need of coal for war purposes lies an equally desperate need of coal to preserve the lives and happiness of the population. The threatened shortage of coal can easily mean unemployment and financial ruin. If you remember that railway locomotives burn more than a quarter of all the coal mined in the country, you will not accuse me of exaggeration when I say that it is in your power and in the power of the railway fireman and the organization with which he works to save enough coal to turn threatened national disaster into national prosperity.

I am especially interested today in getting through to you the full significance in this crisis of every man's "doing his best." Few men ever reach 100 per cent of their possible efficiency. Most of us never reach 50 per cent. Any man who through enthusiasm or other stimulus, gets up to 75 per cent of his possible, is a brilliant success in his field of endeavor. The background of this terrible war is raising the efficiency of every man and woman in the United States. The more the meaning of the war has come home to us, the more we have approached our possible efficiency. This is a real force and should be applied directly to the problem of fuel economy.

There has been much discussion as to what will "win the war." Not every one, I fear, has faced the terrible alternative of what it would mean to lose the war. Let me tell you what I think it would mean.

Only once in civilized times has a single race dominated the world. Only once has a swollen tyranny proved so powerful that no human power could oppose it. The Roman Empire was such a world dominion—brutal, relentless. The Roman Empire could not be destroyed from without—it died from internal decay. But what did this mean to the world? The Roman Empire was one thousand years decaying. A thousand years known in history as the "dark ages." For a thousand years civilization and all that it stands for went backward into darkness.

Here is the black threat of the present struggle as I see it. Another brutal autocracy threatens to slip the leash and get beyond the power of civilization's curb. Another world dominion, another Roman Empire. And it is not of the tyranny, the slavery and misery of that world empire in its heyday that I am thinking. It is of the ages of decay. For a thousand years, perhaps five thousand, the world would struggle in darkness while the German Empire was decaying. In my mind, we are not struggling for the happiness of our children or grandchildren. It is for 50 generations which, if we fail to win this war, may flounder in the black mire of a powerful but decaying German Empire.

It is with such a background that I appeal to you to make the efficiency of your work 100 per cent perfect.

THE FUEL OIL SITUATION

A paper on the fuel oil situation was prepared by M. L. Retqua. In his absence the paper was read by Robert Collett, assistant manager of the Pierce Oil Corporation. An abstract of the paper follows.

The normal increased consumption of fuel oil for the year 1918, based upon the average increase over a period of 14 years, will approximate something over 20,000,000 bbls. An abnormal increase, due to war conditions, will probably greatly add to this amount.

A large percentage of the tank steamers which have hitherto supplied the Atlantic coast refiners with their supply of crude oil from Mexican and Gulf ports have been taken over by the navy for trans-Atlantic service. As a consequence a

material readjustment in transportation facilities becomes necessary. Arrangements have been made by which crude oil deliveries by pipe line to the Atlantic coast will be increased about 26,000 bbls. per day—which is equivalent to about 20,000 bbls. per day of fuel oil. Still further increases in pipe-line capacities are under way which will materially increase their efficiency. But at the very least calculation an additional rail movement in tank cars of about 100,000 bbls. per day will be necessary in order to take care of the urgent fuel oil requirements in the Atlantic coast territory.

It will be necessary to move a great many trainloads of fuel oil for the shipping board and the navy from Texas or Oklahoma to the various ports on the Atlantic coast, and the supply of tank-car equipment will be taxed to its utmost. Any saving in this movement, by substituting coal for oil in the territory east of the Mississippi and permitting the fuel oil so saved to move by the shorter distances from the Indiana-Illinois fields and from the Pennsylvania fields to the Atlantic coast, will represent a very great saving in transportation.

Another feature of our problem is to convince the consumers of petroleum products of the necessity of increasing their storage capacity and to take advantage of the summer months to accumulate storage to carry them over during those months when the transportation facilities will be congested. This applies equally to the railroad companies and those industries that have been in the habit of living from hand to mouth, as it were, in the matter of their oil supplies.

A campaign of education for the prompt unloading of tank cars by the railroad shops is very urgent. Motive power departments particularly have a habit of partly unloading a tank car at one shop, then switching it to another division point for further unloading. In this way they are responsible for the outrageous abuse of tank cars of private ownership.

INDIVIDUAL EFFORT TOWARD FUEL SAVING

BY EUGENE McAULIFFE

Manager, Fuel Conservation Section, Division of Transportation, United States Railroad Administration

The most important angle of my subject to which consideration should be given, is that of individual effort, greater effort, a more unified effort than we have in the past attempted. We are making tremendous strides toward greater individual effort. We have passed the first mile post; but what we who remain at home, we, the real reserve force of the American army must do, is to complete the work of reconstruction of our daily lives so as to make ourselves a living, breathing, fighting part of the country's military force, standing unalterably behind the men who have gone to the front.

War is a contest, not alone of fighting skill, but of mining skill in tons output; of railroad skill as measured by raw and finished materials moved; passengers, including soldiers and sailors, moved. There can be no middle course, we must take on more responsibility. More work. One-third of the man power of the country, or more than ten million men are now directly or indirectly engaged in the war and the end is yet far off. At this time I can only urge effort, studied effort, along the lines you men of experience well know; with the maximum of patience in dealing with the thousands of new men who are entering the mines and the transportation service. A little more effort, a trifle better understanding of the supreme necessity of completing the task we have begun, looking to the present hour as one of cheerful sacrifice, the future one of return, in spiritual and material wealth.

OTHER BUSINESS

The part which the mining industry should play in the solution of the fuel problem was discussed in two papers,

one presented by Harry N. Taylor, vice-president of the Central Coal & Coke Company, Kansas City, Mo., entitled "What the Coal Operator Can Do"; and the other by John P. White, labor adviser of the United States Fuel Administration, on "What the Coal Miner Can Do to Help." The meeting on Friday was also addressed by C. E. Allen, deputy fuel administrator of Illinois, who spoke on "The Supply and Distribution of Fuel."

On Thursday evening motion pictures prepared under the direction of Major E. C. Schmidt of the United States Railroad Administration on the Minneapolis, St. Paul & Sault Ste. Marie were exhibited. These films showed the results of good and poor methods of firing by scenes on the road and close-ups of the interior of fireboxes. The proper methods of building fires were also illustrated and sections of the films pointed out the need of co-operation by employees in all departments of the railroad in order to secure the maximum economy in the use of fuel. Several copies of these films will be sent out by the United States Railroad Admin-

CAR WHEEL DROP PIT

BY J. V. HENRY

The design of a drop pit for car wheels shown in the illustration will interest those in charge of shops where cars must be jacked up when wheels and axles are required to be removed for replacement, tire turning or journal truing. Roads owning their own foundries can make the necessary castings at a nominal expense and, due to present market conditions, even those roads who purchase their castings will find it economical to make their own patterns and purchase the rough castings. If it is not convenient to locate the drop pit in the shop, a suitable location should be found on a track that is not used very much, building a short siding if necessary.

The table consists of two 8-inch I-beams, supporting the track rail, which has a 1-in. depression at the center to prevent the wheels from rolling off the ends while being lowered and raised. Two 6-in. channels, which are fast-

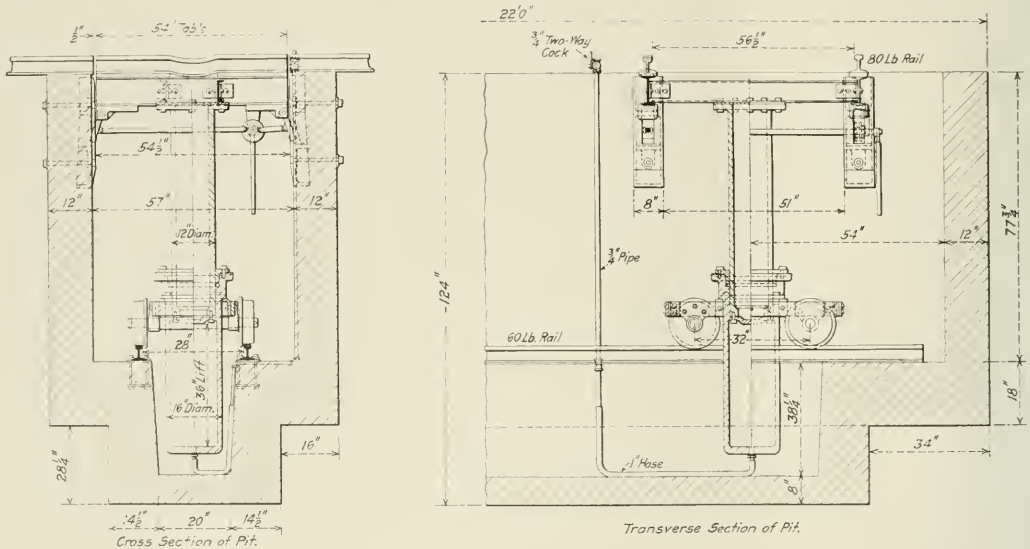

A Convenient Arrangement of Car Wheel Drop Pit

stration and it is the intention to have them exhibited before audiences of railroad men through all sections of the country.

On Friday afternoon a business session was held at which the following officers were elected: President, L. R. Pyle, fuel supervisor M., St. P. & S. Ste. M.; vice-presidents, C. M. Butler, supervisor of fuel, Atlantic Coast Line; J. B. Hurley, road foreman of engines, Wabash Railroad, and H. B. MacFarland, engineer of tests, Atchison, Topeka & Santa Fe; secretary-treasurer, J. G. Crawford, fuel engineer, Chicago, Burlington & Quincy. Executive committee for two years: R. R. Hibben, assistant fuel agent, M. K. & T.; B. P. Phillippe, coal agent, P. R. R.; T. Duff Smith, fuel agent, Grand Trunk Pacific; A. N. Willsie, chairman fuel committee, C. B. & Q.; for one year: H. B. Brown, superintendent fuel department, L. V.; L. J. Joffray, general fuel inspector, I. C.; H. Woods, fuel inspector, C. & A.

During the meetings addresses were made by Sergeant Brown, a Canadian soldier; Trooper Scott, of the Anzacs, and Private Peat. A detachment of the band from the Great Lakes Naval Training Station furnished music for the convention.

ened to the I-beams, also connect to a 12-inch ram, which operates in the cylinder. An air-tight joint is maintained between the cylinder and ram by a split cast iron gland and leather packing. The cylinder is bolted to a four-wheel built up truck operating on 60-lb. rails secured to the foundation by 3/8-in. anchor bolts.

The table, when not in use, is supported by a latch arrangement consisting of a latch plate set in the foundation, and a bearing bolted to the 8-in. I-beams, in which the latch works. The latch is operated by means of an operating cam and levers, the table being raised slightly to disengage the latch from the plate when it is desired to lower the table.

The arrangement shows the table operated by means of air from a 3/4-in. pipe leading through a two-way cock to a 1-in. hose, which is of suitable length to allow the table to make its full transverse travel. If desired, hydraulic pressure can be used to operate the table. For a pit of this depth, a drain will be required to allow the water to run off.

The value of this drop pit is due to the considerable saving in the time and labor required to jack up a car, remove the truck, jack it up and change the defective wheels.



NEW DEVICES

MOTOR DRIVEN GEARED HEAD LATHE

A motor driven geared-head lathe of high power, built by the Springfield Machine Tool Company, Springfield, Ohio, is shown in the illustration. It has several features which make it well adapted to railway machine shop use. The lathe is simple in construction and operation and is of heavy

any series of speeds in order to reach the one best adapted to the work being done.

The entire head mechanism is enclosed in an oil-tight case, all gears running in a bath of oil and all bearings having stream lubrication. The main spindle journals are supplied with sight feed oilers in order to show that the proper amount of lubrication is being obtained.

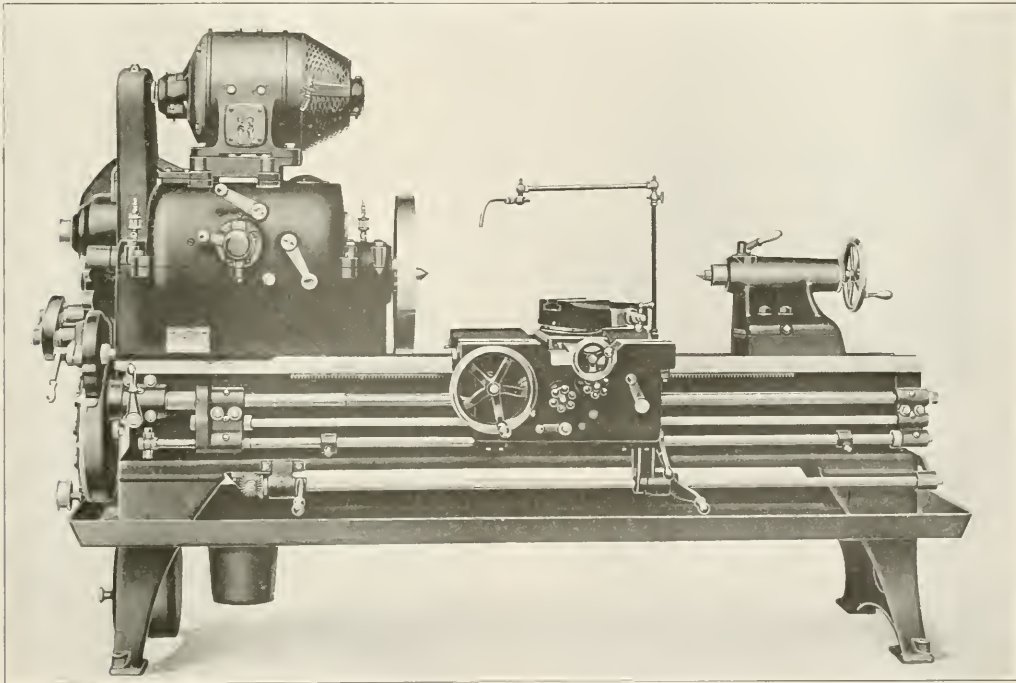

General View of 18-In. Motor Driven Geared Head Lathe

design, having a particularly large range of speeds. All gears run in oil and with the selective type head there is no running of unnecessary gears. The lathe may be arranged for belt or motor drive. All journals in this lathe, excepting the main spindle journals are ball-bearing and a ball thrust bearing is also provided. Twelve speeds in geometrical progression are obtained by means of 14 gears. The power is transmitted from the belt to the spindle with the least number of gears possible. Any speed may be directly obtained and it is not necessary to pass through

The clutch pulley is on the rear of the head and contains a friction clutch operated by a push rod, which allows the lathe to be started and stopped instantly. The head may be furnished with a reversible drive if desired.

The construction of the lathe in general is compact, permitting all shafts to be short and of large diameter, which reduces chatter and vibration, and permits smooth finishing cuts. All operating levers are in front of the head and readily accessible which insures easy operation and maximum production. The lathe can be furnished in four sizes,

14 in., 16 in., 18 in., and 20 in. The dimensions of the 18 in. lathe are as follows:

Swing over bed	19 in.
Swing over carriage	13 in.
Distance between centers for 6-ft. bed	1 ft. 6 in.
Front bearings	33 1/2 in. by 7 in.
Rear bearing	24 in. by 5 1/4 in.
Hole in spindle	1 9/16 in.
Diameter of spindle nose	2 1/4 in.
Threads on spindle nose	4 threads Acme
Number of spindle speeds	12
Diameter of head pulley	14 in.
R.p.m. of head pulley	325
Spindle speed range with the above	9 to 380
Speed of countershaft	325
Size of C. F. friction pulley	14 in. by 4 1/4 in.
Motor drive horsepower recommended	3.5
Speed of motor	1,200

BULLARD 61-IN. MAXI-MILL

The most recent development of the Bullard Machine Tool Company, Bridgeport, Conn., in vertical boring and turning mill construction is embodied in its 61-in. Maxi-

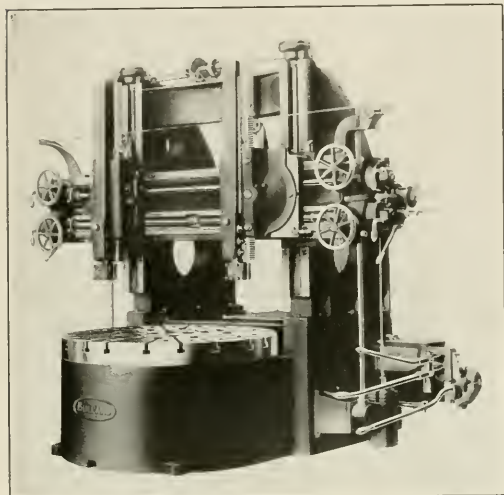

Fig. 1—Bullard 61-In. Maxi-Mill

Mill. A general view of this machine is shown in Fig. 1. Although the general design of the machine is new, most of

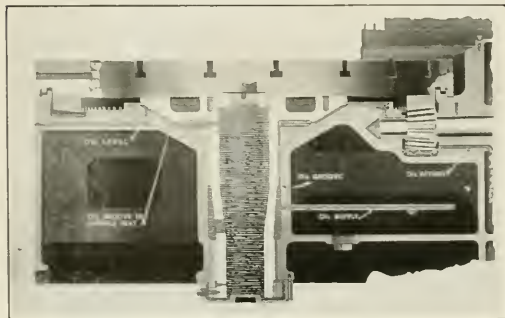

Fig. 3—Table Spindle and Oiling Arrangement

the units, such as the drive arrangement, feed mechanism, spindle construction and lubrication system have been adapted from tools of previous design where they have dem-

onstrated their value. The special features of this machine are its power, rigidity, ability to take heavy cuts and the elimination of waste time in its operation.

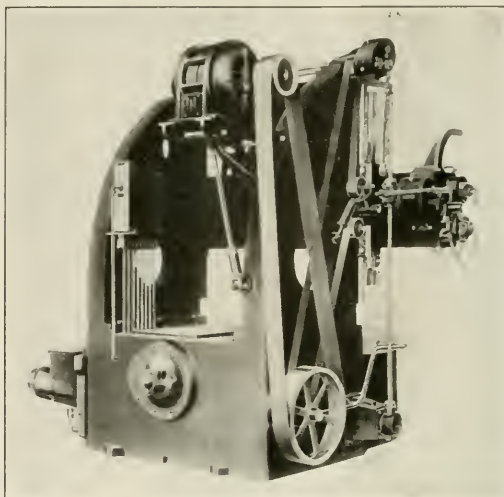

Fig. 2—Rear View Showing Oiling System and Motor Drive

The steel gears and shafts throughout are made of heat treated chrome nickel steel. The continuous flow system of lubrication of all gears, bearings and spindles with an in-

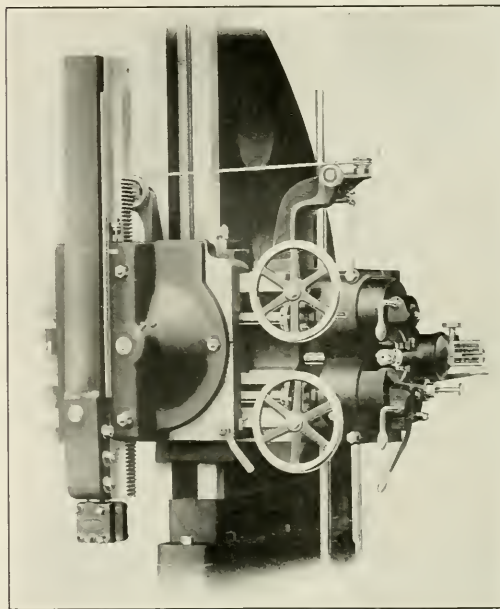

Fig. 4—Right Hand Head Showing Feed Mechanism

tegral filter insures cleanliness of the oil and freedom from delays due to scored bearings and overheated boxes. Fig. 2 shows the oiling system and also the motor drive arrange-

ment, the left-hand clutch and brake lever, the power traverse head and the left-hand feed work.

The method of oiling the table is illustrated in Fig. 3. Oil is maintained at a constant level and a continuous stream fills the reservoir. In overflowing the oil lubricates the table gear and pinion as well as the bearings.

The gear is centralized, and the convenient arrangement of control handles, which is indicated in Fig. 1, adds to the productiveness of the machine. The control clutch and brake for starting and stopping the table is within easy

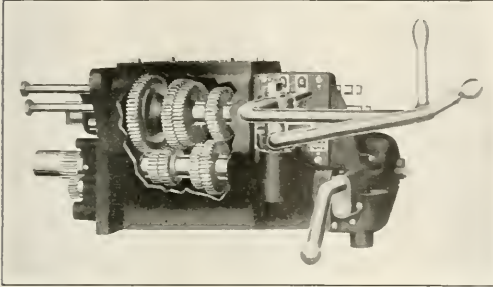

Fig. 5—Primary Speed Change Case

reach whether the operator be on the right or left hand side of the machine.

The ability to use large amounts of cutting lubricant without the possibility of its entrance into the machine itself, is an item of considerable importance which has been kept in mind in the design of every detail and is the result of a series of experiments extending over a period of four years.

Crank handles on shafts revolved at high speeds to obtain rapid traverse of the head are dangerous and have been eliminated. Patented hammer handwheels, shown in Fig. 4, which put lost motion to good use and eliminate all danger, actually increase the operator's ability to obtain fine settings of the tools. The clearly graduated scale mounted on the tool slide gives the coarser settings and micrometer dials,

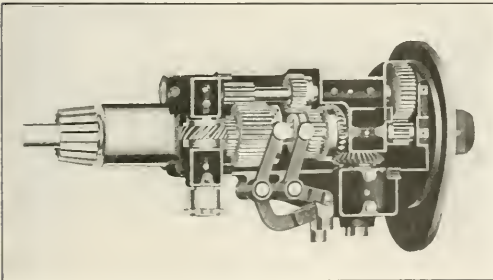

Fig. 6—Secondary Speed Change Case

giving graduations to thousandths of an inch, give the finer readings. The same arrangement of graduated scale is used on the face of the cross-rail.

The primary speed change case is shown in Fig. 5, and the control levers and interlocking system, together with the gearing arrangement are plainly indicated. Fig. 6 shows the secondary speed change case which is built for maximum power and durability.

The 61-in. Maxi-Mill is adapted to machine work up to 61 in. in diameter, 52 in. high under the cross-rail and 52 in. under the toolholders. The table is provided with par-

allel T-slots for the use of four face-plate jaws. There are 12 table speed changes ranging from 2.5 to 42.18 r.p.m. made by sliding gears and positive friction clutches. These are operated by conveniently located levers which interlock with the clutch and brake lever. Eight feed changes range from 1-96 in. to 1/2 in. per revolution of the table, either vertically or horizontally.

The tool slides are of special high tensile cast iron in the box form, with inserted tool holders. A vertical movement of 36 in. is obtained by means of a steel rack and pinion and the tool slide may be swiveled 45 deg. either way. All gears and shafts are made of heat treated, oil tempered, alloy steel, except the table drive gear which is of such design and dimensions as to preclude heat treatment. The hardness of all gears is 70 as measured by the scleroscope. All gears are encased, but are readily accessible and the table is guarded.

The bearings and gears with a fixed relation to the bed are lubricated by a continuous flow system by which filtered oil is circulated through a pump directly connected to the main drive shaft. This pump operates at all times when the main driving wheel is in motion.

The 24-in. driving pulley has a 5 1/2-in. face and should run at 405 r.p.m. The best source of power is a constant speed motor of 15 hp. The weight of the machine is 28,000 lb. net and the floor space required with motor drive is 11 ft. by 13 ft. The height of the machine with the bars in the extreme upper position is 130 in.

ARCH BAR DRILLING MACHINE

The six-spindle arch bar drilling machine illustrated, which is made by the Foot-Burt Company, Cleveland, Ohio, is especially adapted to the heavy duty drilling of modern truck arch bars. For the sake of greater rigidity the heads of the machine which carry the spindles are bolted securely to the main cross-rail and are adjustable for the taking of different sizes of arch bars. The table is of the heavy box

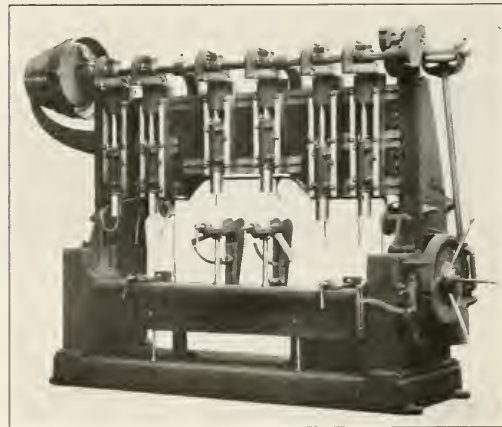

Foot-Burt Six Spindle Arch Bar Drilling Machine.

section type, well ribbed, and is fed up to the spindles by means of heavy racks and pinions. The pitch line of these racks and pinions is directly under the center of the spindles.

The ways of the table are also directly in line with the center of the spindles, thereby eliminating all overhang to the table and allowing it to feed up directly against the center of the spindles. The uprights are of heavy box sec-

tion type, as well as the cross-rail, which is strongly ribbed to withstand unusual strain.

The spindles are carried in bearings which are bronze bushed, and these bearings are adjustable vertically 5 in. to take care of the different lengths of drills. All spindles are fitted with ball thrust bearings. The driving bevel gears for the spindles are made of steel forgings with hardened planed teeth.

The machine is now arranged with four changes of feeds by means of transposing gears on the end. The clamping mechanism for holding all the different sizes of arch bars, required to be drilled will be found convenient to operate and efficient. The machine is furnished complete with oil pump, piping and tank, the machine table being arranged with a large oil groove extending entirely around the outside. A suitable supply of cooling compound is thus provided for

A HEAVY 42-INCH PLANER

The 42-in. planer shown in Fig. 1 is manufactured by the Bickett Machine & Manufacturing Company, and is built from new patterns throughout. This design is heavy and is adapted for both heavy and light work.

The bed of the planer, shown to the best advantage in Fig. 1, is of the solid, box type, especially heavy where gearings and housings are mounted, the bearings for the bull wheel shaft being $8\frac{1}{2}$ in. long. Heavy box girths at short intervals securely tie the walls together. The V's are wide and well proportioned, so that there is no possibility of the table tilting, even in making heavy cuts at the extreme edge of the table.

The oiling system has had special consideration. Besides being fitted with the usual automatic oil rollers, all pockets

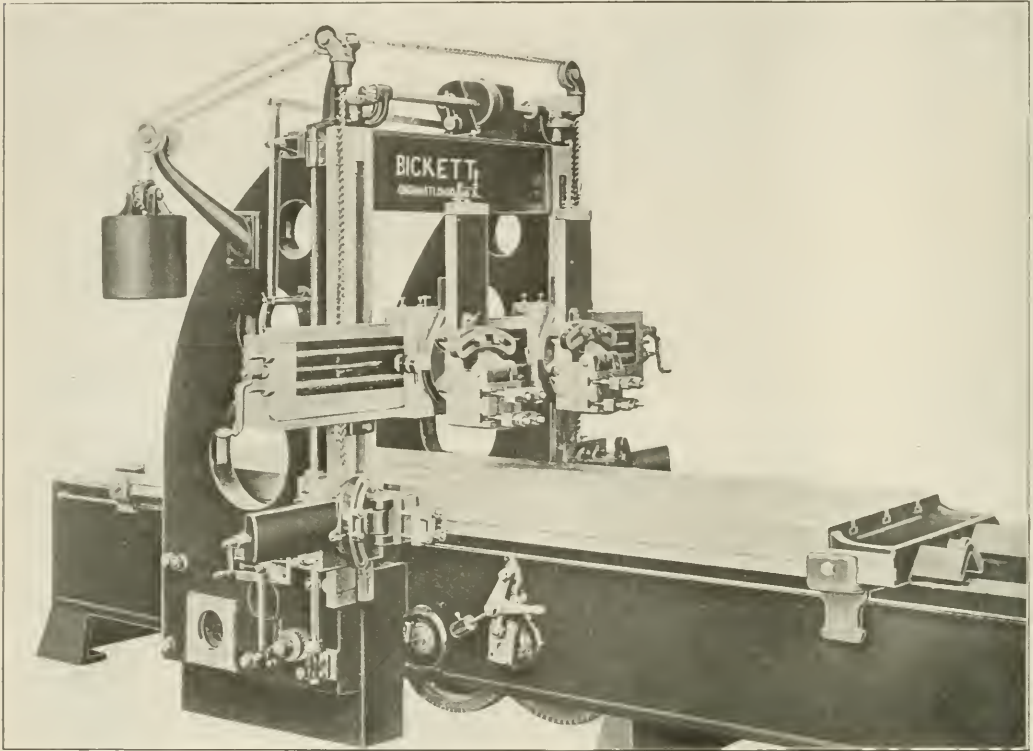

Fig. 1—A 42-In. Bickett Planer Designed for Heavy Work

which makes it possible to force the drills to the limit of their capacity.

The Foot-Burt Company is prepared to furnish this arch bar drill with eight spindles, the two center heads of the machine in that case being arranged with the spindles set at fixed centers, but adjustable between each pair of fixed center spindles to handle arch bars when designed with eight holes.

LOCOMOTIVE PRICES IN ENGLAND.—The Taff Vale Railway of England has recently given orders for some new locomotives which, the chairman of the railway company says, will cost £7,000 (\$35,000) each instead of the pre-war price of £2,300 (\$11,500) each.

are connected by pipes, making lubrication uniform throughout the entire length of table and bed and reducing the possibility of abrasion or cutting.

The table is of substantial construction, with heavy ribs at short intervals to guard against any possibility of springing. The "T" slots run the full length and are planed from the solid metal. Stop holes are drilled and reamed throughout the table, and countersunk to prevent chipping. Suitable dirt guards prevent any dirt getting in the V's. Each section of the rack is secured to the table by dowel pins, in addition to heavy cap screws.

The housings are of the box type, with heavy ledges resting on the cheeks of the bed, which support the entire weight of the housing and top arch. One-inch by one-inch steel

keys between the cheeks of the bed and the housings prevent them from moving or getting out of line. Housings are securely bolted to the bed with tapered bolts and dowel pins and fastened together at the top by a heavy boxed arch, which assures absolute rigidity when the cross rail is at the highest point.

The faces are accurately scraped, trued to surface plates, and carefully aligned, to be sure that they are parallel and perfectly square on the bed. Taper bolts are used throughout for greater accuracy and rigidity.

The full width of the machine can be used by one head, the cross rail being of such length that the other head can

each side of zero, giving wide range in adjusting the tool. The cross feed and down feed screws and rods are provided with adjustable ball bearings, taking thrust both ways, thus increasing their efficiency and making the operation much easier.

The planers can be equipped with one or two side heads, as desired, or they may be attached at any time after the purchase of the machine. They are provided with independent power and hand vertical feed, and can be run below the top of the table when not in use. Counterbalance weights and chains for the side heads are furnished with them.

Side heads are independent of each other and of the cross rail heads, and can be used separately, or in conjunction with the cross rail heads as desired.

The screws which control the feeds are furnished with micrometer readings in thousandths of an inch, and the handles are always convenient to the hand of the operator. The adjustment of the vertical feed screw nut avoids any possible chance of back lash in the feed screw.

The control mechanism is on the outside of the machine and is readily accessible for all adjustments and oiling. A safety link on the control lever makes it impossible for the operator to lose control of the machine, and a safety lock holds the planer while work is being set up.

The elevating gear box located on top of the arch is

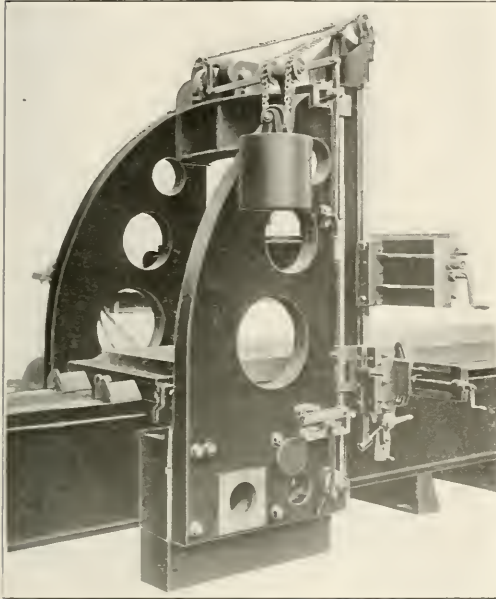

Fig. 2—Large Housings Are Rigidly Connected

be run to the extreme end, to avoid interference with the working head.

The cross rail is of great depth and has a deep curved back. The distribution of metal is such as to resist the torsion of heavy cuts, eliminate the possibility of chatter, and make accurate and well finished work. Bearing surfaces are accurately scraped to straight edges and surface plates, and the back is scraped to the bearings on the face of the housing. Tightening screws are provided for securely clamping the slide to the swing and the saddle to the rail without disturbing the normal adjustment of the gib. Right and left hand saddles are used, making it possible to work the heads close together. Thrust ball bearings on both rail screws and the rail rod mean long life and ease of operation.

The rail heads are made of extra heavy design, fitted with a wedge gib having only one regulating stud at the top end, which makes the tool solid at any position or angle. The tool bolts are made with a large thread, assuring rigid clamping of the tool in the tool holder, which has hardened serrated tool plates.

The clapper boxes are of a heavy design and accurately made. The vertical feed range on the 42-in. planer is 15 in., and all heads are equipped with micrometers reading in thousandths of an inch. Heads are graduated at 45 deg.

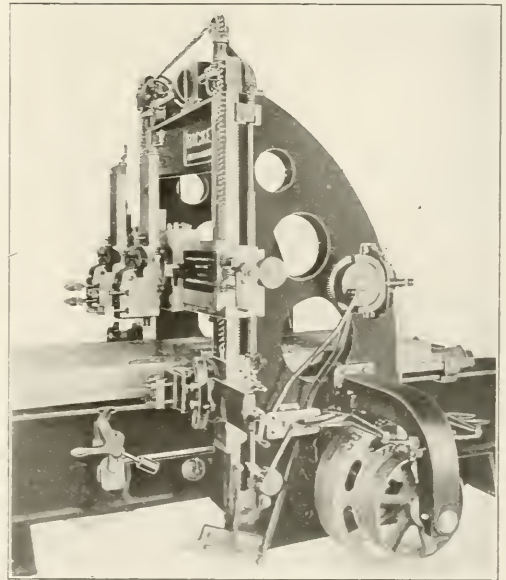

Fig. 3—Arrangement of Driving Pulleys and Operating Levers

driven by a separate belt, and has gears of wide faces and large pitch, that are always in mesh. Shift is made by a positive clutch, the shaft and pulley being the only parts revolving when not in use. The automatic positive feed has an oscillating yoke controlled by movements of the cam plate of the belt shifter. The feed rack for the cross rail is accurately cut from bar steel, and meshes with steel pinions of heavy pitch. The ratchet pinion on the rail rod and screw have knurled caps for feed changes, which are very convenient and quick in action. All feeds can be changed from fine to coarse without stopping the planer, and may be stopped and reversed instantly.

Perforated aluminum pulleys allow the escapement of air and causes the belts to adhere, thereby eliminating the noise and slipping due to the rapid shifting of belts when running at high speed. Wide-faced driving gears are mounted on extra heavy shafting within the bed, and the bearing bushings are ample to eliminate all possibility of cutting, undue heating or any friction of moving parts. All gears are covered with a one-piece gear guard, thus insuring the safety of the operator.

READY BORING TOOL HOLDER

The boring tool holder illustrated was recently designed by the Ready Tool Company, Bridgeport, Conn., for use in vertical turret lathes or boring mills where an exceptionally rigid holder is necessary. It can be furnished in two sizes: No. 1, 1 $\frac{1}{4}$ in. by 1 $\frac{1}{4}$ in. by 6 in. with 1 $\frac{1}{2}$ -in. square high

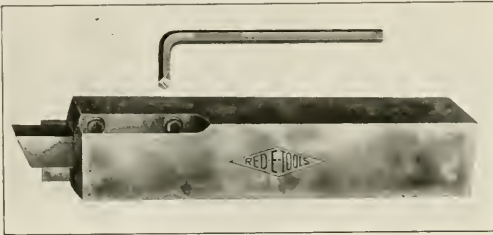

Ready Boring Tool Holder

speed cutter, and No. 2, 1 $\frac{1}{2}$ in. by 1 $\frac{1}{2}$ in. by 7 in. with 5/8-in. square high speed cutter. By drawing out scrap high speed tools into 1/2-in.- and 5/8-in. square tool bits to be used in the holders a material saving of high speed steel will be effected.

The tool holder is designed to be used either right or left

AMERICAN 36-IN. HIGH DUTY LATHE

Simplicity in machine tool design is one of the most important factors in high production. Regardless of the power, range and rigidity of a lathe, if it cannot be handled easily and quickly by the operator, or if there is a lot of unnecessary and complicated mechanism to contend with, the tool will never be an efficient producer or a money maker. With this point in mind, the American Tool Works Company, Cincinnati, Ohio, has recently designed a 36-in. heavy pattern geared head lathe particularly adaptable to railway machine shop use.

Being intended for heavy work and heavy cuts, the construction of the machine is substantial throughout and follows the standard practice of the American Tool Works Company in lathe design. The thrust bearing provided with this lathe consists of five collars alternately of bronze and hardened and ground steel. All bearings throughout the machine are furnished with renewable bronze bushings and the loose gears in the apron are also lined with bronze. The studs on which they run are casehardened and ground, thus providing a hard bearing surface without impairing the strength. The apron is of the usual double wall or box construction. The thread dial is placed at the right of the apron and can be readily disengaged from the lead screw when not in use.

The new type of patented geared head for the machine illustrated now contains only 16 gears and three shafts besides the spindle, to produce the entire range of 16 spindle speeds. These speeds are in geometrical progression and are calculated to provide a proper cutting speed for all diameters likely to be turned on a 36-in. lathe. The entire design and construction of the head makes it adaptable to the heaviest class of lathe work, such as is found in railway shops, steel mills, etc. The greatest speed reduction through the face plate drive is 237 to 1, and this unusually high ratio gives some idea of the available power. At the normal countershaft speed the belt will deliver from 30 to 35 hp.

The lathe may be arranged for motor drive by mounting

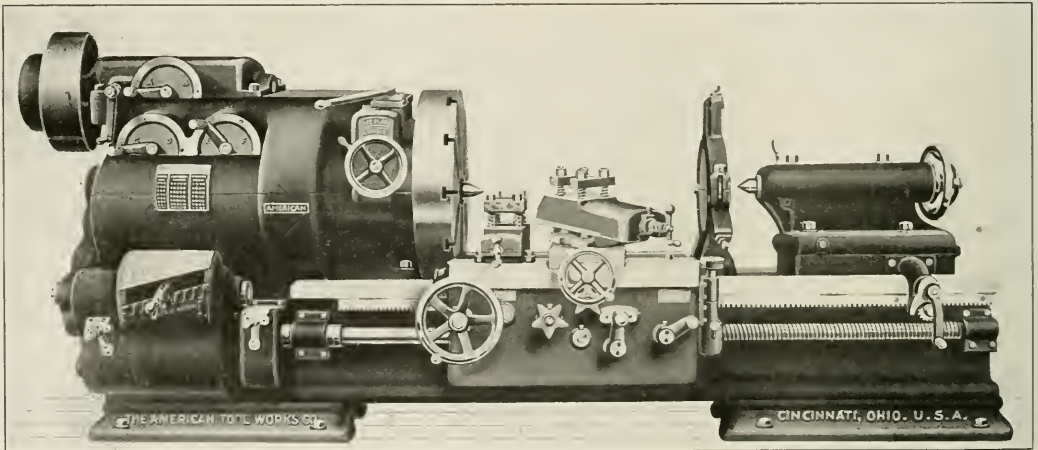

The American 36-In. Heavy Geared Head Lathe

hand, and the cutter is supported on the bottom and backed up against the feed of the cut. The cutter is held by hollow set screws and there are no projecting screw heads to interfere with the proper setting of the holder in the tool post. The holder is case-hardened inside and out, making it both rigid and durable.

a constant speed motor either of the direct or alternating current type on top of the geared head. The motor is connected to the main driving shaft through three spur gears. When apron control is furnished, the motor can be started and stopped by means of a controller handwheel conveniently located on the right end of the carriage. The size of

the motor depends upon the nature of the work to be handled and it is usually specified by the customer after a thorough investigation of the uses to which the lathe is to be put.

All head gears run in oil. All the bearings are bronze bushed and arranged to be well lubricated. A sensitive control is provided through a large and powerful starting and stopping friction located on an extension to the initial driving shaft, which operates in conjunction with an effective brake. By this means the spindle can be quickly started and stopped, which is especially convenient for the operator when he wishes to examine his work.

The lathe can be furnished with any length of bed from 12 ft. up, advancing by 1-ft. lengths. The following are the general dimensions:

Swing over bed.....	37 3/4 in.
Swing over compound rest slide.....	23 3/8 in.
Standard length of bed.....	12 ft.
12-ft. bed takes between centers, tailstock flush, geared head.....	5 ft. 1 1/2 in.
12-ft. bed takes between centers, tailstock flush, cone head.....	5 ft. 1 1/2 in.
Hole through spindle to clear bar.....	2 7/8 in.
Size of tool ordinarily used.....	1 in. by 2 in.
Taper of centers, Morse.....	No. 6
Power angular feed to compound rest.....	.15 in.
Width of driving belt—geared head.....	6 in.
Diameter of driving pulley—geared head.....	20 in.
Speed of driving pulley, r. p. m.—geared head.....	475
Width of driving belt—cone head.....	5 1/2 in.

UNIVERSAL FLAT TURRET LATHE

A new universal flat turret lathe with several distinctive and meritorious features has been produced by the Acme Machine Tool Company, Cincinnati, Ohio, and is called the No. 3 Cincinnati Acme universal flat turret lathe. This machine is shown in Fig. 1 and attention is called to the cross movement provided for the turret, as well as for the

saddle. All controlling levers are arranged to be within convenient reach of the operator and are out of the way when lifting heavy work in or out of the chucks.

This turret lathe can be furnished with an automatic chuck for bar work, or a general service chuck such as shown in Fig. 1. This chuck will accommodate work up to 17 in. in diameter and bar stock up to 3 1/2 in. in diameter and 44 in. long. The actual swing over the bed is 24 in. The machine is especially adapted to chucking work through the advantages of the side carriage with which it is provided. This carriage permitting multiple tool operations, makes it possible to machine castings or forgings with a small number of chuckings. The carriage may also be used to advantage when doing bar work.

Every effort has been made to secure a machine as simple, accurate and rigid in construction as possible. The head is cast solid with the bed, maintaining constant and perfect alignment of spindles with the vees upon which the turret carriage travels. The ways of the bed are exceptionally large and wide. Taper gibs are furnished to take up the wear.

The geared head is simple in construction and a maximum pulling power together with nine different speeds is obtained with a small number of gears. The speeds range from 14 to 280 r.p.m., and are obtained instantly without stopping the spindle, by the use of two levers conveniently located at the front of the head. The patented gear shifting device makes possible the change from one speed to another with one continuous movement of either of the speed changing levers. When the lever has reached the point where the gears are out of mesh, the driving pulley is automatically disengaged from the driving friction and re-en-

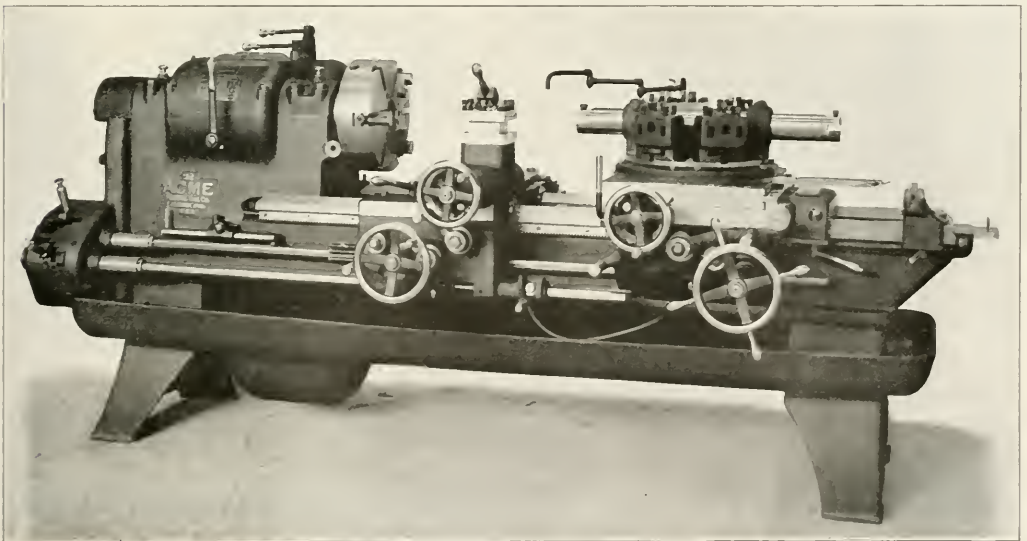

Fig. 1—Cincinnati Acme No. 3 Universal Flat Turret Lathe

auxiliary carriage, thus permitting the easy machining of work off center. Other features are the permanent alignment of the spindle with vees and cross slides, single pulley drive and sliding gear transmission. All gears run in an oil bath, are controlled by a patented gear shifting device and speeds may be changed instantly without stopping the spindle. There are safety stops in all directions and arrangement is made for power rapid traverse of the turret

gaged after the gears are again completely in mesh. This feature enables the gears to be shifted from one speed to another while they are only turning over from their own momentum, eliminating all shock and pick-up.

The side carriage shown in Fig. 2 spans the ways of the bed, eliminating all overhang to the turret and tools, and is so constructed that it clears the chuck and can be moved out of the way to permit the use of short tools in the flat

turret. It is provided with six independent stops for the longitudinal movement, which are easily accessible to the operator. The square turret is mounted on the cross slide and is held in position by a hardened lock bolt, located directly above the cutting tool.

The cross sliding turret revolves on a hardened and ground stem of large diameter and is automatically locked into position by a hardened and ground tool steel taper plunger, placed directly underneath the cutting tool. This plunger works in ground taper bushings set into the solid turret and as near the outer edge as practicable. The turret is further held down at the extreme outer edge with circular clamps. Oiling arrangement is provided so that oil can be fed to each individual tool. The cross slide moves on a long, narrow, dove-tailed guide with wide flat bearing surfaces on either side and has an adjustable taper gib to compensate for wear. An adjustable hardened center stop is also provided. The cross feed can be operated in both directions by hand or power.

Power rapid traverse is provided in either direction longitudinally for the turret and is operated by a lever conveniently located at the front of the saddle. This feature creates a great saving in time and energy. Twelve

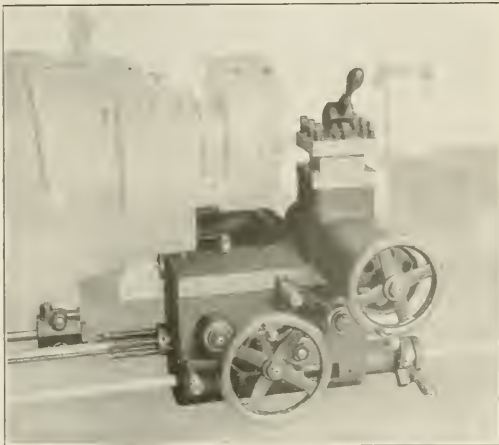

Fig. 2—Sliding Carriage Showing Apron and Independent Stops

longitudinal stops are provided, one independent stop for each turret face and six auxiliary stops, which are operated by the index knob at the right of the saddle. Power feed is provided for the cross and longitudinal movement to both the side carriage and turret. The gear box at the head end of the machine furnishes ten feeds from 10 to 240. Stops are provided for the longitudinal movement and for the cross movement a large micrometer dial with observation stops. All feeds can be reversed by operating levers conveniently placed in the aprons and within easy reach of the operator.

The bed is both deep and wide to give rigidity under heavy cuts and is strongly braced by crossed girths. The vees are exceptionally large to allow for the load of the apron and the side carriage. The pan is made deep and an oil reservoir is attached. A perforated cover serves as a strainer and allows the oil to drain back into the reservoir. A geared oil pump is furnished which provides an ample supply of oil when the machine is running in either direction. Of the two pipe lines furnished, one is for turret tools and the other for the side carriage.

A plain, tight and loose pulley countershaft is furnished

and where conditions permit the use of the overhead countershaft can be avoided by belting the machine direct to the line shaft. In case a motor drive is desired a 5 to 7.5 hp. constant speed motor of 1,200 to 1,800 r.p.m. is recommended. By placing the motor on a sliding base on the floor at the head end of the machine it can be belted to the driving pulley. The general dimensions of the lathe are as follows:

Diameter can be turned.....	17 in.
Swing over carriage.....	17 in.
Swing over bed.....	24 in.
Hole through spindle.....	3 3/4 in.
Spindle speeds, r.p.m.....	14, 21, 30, 46, 66, 93, 140, 200, 280
Diameter of driving pulley.....	14 in.
Driving pulley, r.p.m.....	650
Revolution of spindle to feed turret and carriage 1 in. (cross)	10, 14, 20, 28, 40, 60, 85, 120, 170, 240
Revolution of spindle to feed turret and carriage 1 in. (long)	10, 14, 20, 28, 40, 60, 85, 120, 170, 240
Diameter of turret.....	18 in.
Distance from center of spindle to top of turret.....	4 in.
Travel of turret cross.....	8 in.
Travel of turret longitudinal.....	44 in.
Center distance between vees.....	14 in.
Depth of bed.....	12 1/2 in.
Width of bottom of vees.....	2 1/2 in.
Countershaft pulleys (tight and loose).....	14 in.
Width of countershaft belt.....	4 in.
Countershaft pulley r.p.m.....	570
Floor space.....	3 ft. 6 in. by 11 ft. 2 in.
Weight, plain machine.....	net 6,750 lb.

The following equipment is furnished with the turret lathe for chucking work:

- 1—15 in. 3 jaw chuck with reversible jaws.
- 1—16 in. face plate with bolts and clamps.
- 2—Tool blocks.
- 2—Tool plates.
- 12—Turning cutters.
- 6—Boring cutters
- 1—1 1/2 in. boring bars and cutters.
- 1—3 1/8 in. boring bar for turning and boring.
- 1—Extension drill support with four taper sockets and stand-ard taper shanks.

PEERLESS REAMERS

The illustrations show two Peerless high speed reamers manufactured by the Cleveland Twist Drill Company, Cleveland, Ohio, and the special feature in their construction is the permanent setting of high speed steel blades in a carbon steel body by a process known as "Brazo-Hardening." This method secures the blades permanently in the reamer body and the work of fitting is so carefully done that only a close examination will show that the reamer is not made entirely from one piece of steel.

This gives a tool with high speed steel cutting edges and a body that is tough, resilient and difficult to break. Such a combination is impossible to obtain with a reamer made entirely of high speed steel.

Referring to the illustration, reamer No. 503 is a Peerless straight shank chucking reamer, and No. 504 is a

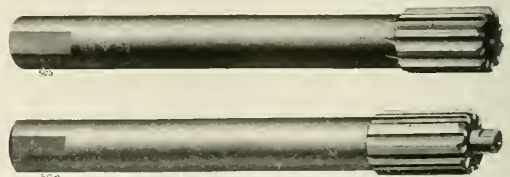

Straight Shank Peerless Reamers

straight shank expansion chucking reamer. Both of the above reamers have given good satisfaction in actual service and would be valuable in railway shops where a tough, strong tool is required and the character of the work ne-

cessitates high speed steel cutting edges. The reamers illustrated are but two of 21 different types, including expansion and turret lathe types.

HYDRAULIC BENDING PRESS

A new design of hydraulic bending and straightening press has been brought out recently by the Hydraulic Press Manufacturing Company, Mt. Gilead, Ohio. It is an item of shop equipment of particular convenience and utility, being self-



Hydraulic Bending and Straightening Press

contained and adaptable to a large range of uses. In railway shops the valve setters will find this press valuable for such work as bending valve rods, changing the off-set

in link hangers, etc. The bed of the press is 12 in. by 32 in. and the working height is 15 1/4 in. The 6 in. ram has a travel of 4 in. and a rack and pinion is provided to bring it up to the work before starting the pressure pump. The pressure is applied and controlled by a hand operated pump, conveniently mounted on top of the cylinder. A forged steel cylinder is used being designed for extra heavy pressure, the maximum allowable being 5,400 lb. per sq. in. One T-slot extending the length of the bed, holds the adjustable straightening blocks. The press rests on a bench or special pedestal, and occupies a small amount of floor space.

COMBINATION AXLE AND JOURNAL TURNING LATHE

In view of the increasing demand for a machine to turn car wheel journals without removing the wheels from the axles, the Niles-Bement-Pond Co. has recently developed a combined axle and journal turning lathe. The illustration shows this lathe with the upper portions of the bed pushed back, thus forming a gap to receive the wheels. The gaps on either side may easily be closed and the carriages will then travel back and forth as in the case of a common axle lathe.

The lathe is of the center drive type with the driving gear in halves and driven by a pinion carried in the bed. The center head has a hinged cap, which forms a continuous bearing for the center gear, and also completely covers the gear. The cap is clamped by one large hinged bolt and is counterweighted. Provision is made so that when the cap is swung up, it automatically lifts the top half of the main driving gear, making it easy to place in or take from the lathe an axle with or without mounted wheels. Either operation may be quickly performed.

There are four carriages on the lathe; two for the inside journal turning, and two for the outside turning. When the machine is used as an ordinary axle lathe for outside journal axles, the two outside carriages are used for turning the collars, outside journals, sand guards and wheel seats. When used as an ordinary axle lathe for inside journal axles, the two outside carriages are used for wheel seats and the two inside carriages for the journals. All four carriages are fitted with screw feeds operated by bronze open and closed nuts.

There are two tailstocks carried on the upper bed members and they each have spindles adjustable by hand wheels. The axles are driven by hinged dogs through a double

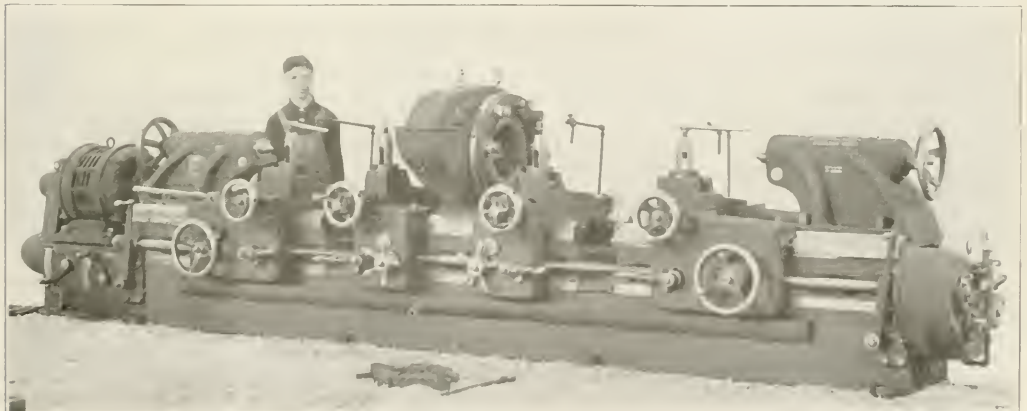

Niles-Bement-Pond Combination Axle and Journal Turning Lathe

equalizer drive plate of a similar type to that used on the standard Niles-Bement-Pond axle lathe.

There are three changes of feed from $1\frac{1}{2}$ in. to $\frac{1}{4}$ in. provided for the carriages, the adjustment being made by means of a pull pin. The machine is fitted with a pump and suitable drainage system.

In case it is desired to drive the lathe from overhead shafting a two speed counter shaft is furnished and a three step cone pulley gives six speeds to the driving head, ranging from 16 to 48 r.p.m.

The same speed variation may also be obtained by means of a 15-hp. direct or alternating current motor. In this case the motor is mounted on a base plate attached to the left hand end of the bed and is geared directly to the driving shaft.

The principal dimensions of the lathe are as follows:

Swing over lower bed or sole plate	45 in.
Swing over upper bed	30 in.
Swing over carriage	15 in.
Maximum distance between centers	7 ft. 9 in.
Main bearing diameter	16 in.
Main bearing length	13 in.

FOSTER UNIVERSAL TURRET LATHE

The machine illustrated in Fig. 1 is a new combination turret lathe for both bar and chucking work, known as the 2-B universal turret lathe, built by the Foster Machine Company, Elkhart, Ind. This turret lathe is designed to handle bar work up to $3\frac{1}{4}$ in. in diameter and 30 in. in length,

Twelve speed changes ranging from 12 to 825 r.p.m. are obtained by means of sliding gears in the lathe head. These gears run in an oil bath and all bearings in the head are automatically lubricated by the splash from the gears. The levers for operating the speed and feed changes are mounted conveniently on top of the head cover as shown in Figs. 1 and 2. The start, stop and reverse friction clutch is mounted on the back gear shaft and operated by the lever shown directly over the front spindle box.

The lathe bed is well proportioned and heavily ribbed internally, which makes it capable of resisting heavy cutting strains without vibration or deflection. A four-in. belt running at a speed of 1,960 ft. per minute delivers to the machine $8\frac{1}{2}$ hp., which is sufficient to allow four or five simultaneous cuts to be taken with a comparatively coarse feed. The friction clutch is well designed and capable of transmitting about twice the above load. The sliding gears in the head are of the Fellows stub tooth type.

The cross slide carriage is shown in Fig. 2. The rear end of the cross slide is built in the shape of a table on which standard or special tool holders may be mounted. The square turret mounted on the cross slide is indexed and locked by means of the lever handle shown at the top. The lock bolt which is of the cylindrical, vertically mounted type, is located directly underneath the working position of the cutting tool. Fig. 3 shows in detail the screw cutting attachment and the six carriage stops.

The six independent and adjustable stop screws are mounted on an index stop spool and are used for the pur-

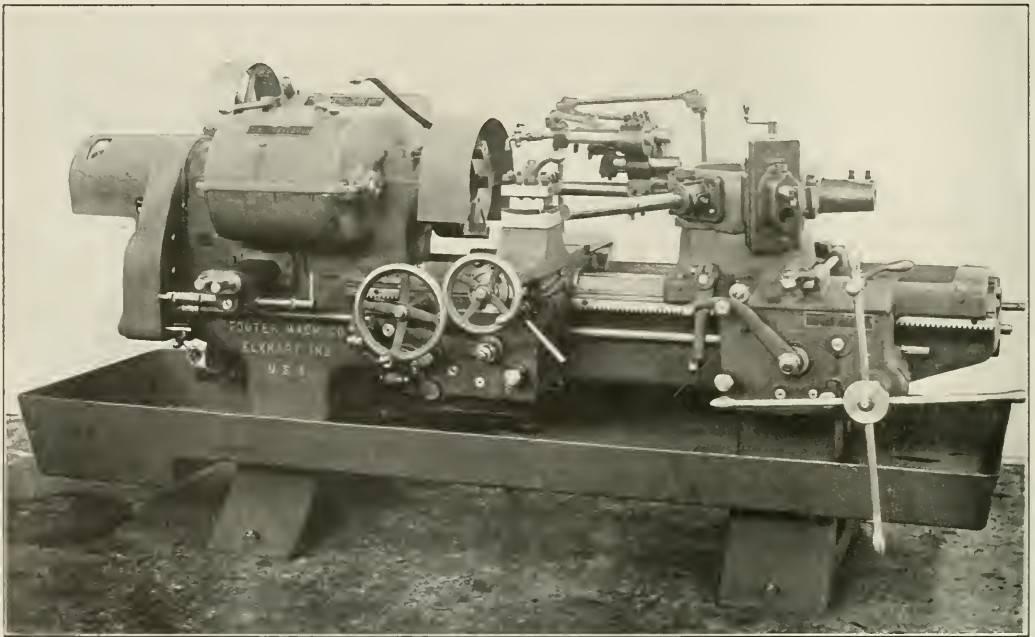

Fig. 1—Foster 2-B Universal Turret Lathe with Chucking Equipment

and clucking work up to 15 in. in diameter. Due to the larger swing over the horns of the carriage, however, it is possible to handle light chucking work up to 20 in. in diameter. The machine is called universal on account of its adaptability to widely varying kinds of work, its extensive and well-balanced speed and feed ranges, and numerous standard and special tool attachments.

pose of longitudinal gaging and duplicating the work. For duplicating and gaging diameters of the work a large diameter dial is mounted on the cross speed screw and it also has adjustable observation stops. The cross speed is disengaged by means of the short lever shown pointing to the right on the carriage apron.

Twelve speed changes for the longitudinal feed range from

.0055 in. to .15 in. per spindle revolution. The range for cross feed is from .0029 in. to .080 in. per spindle revolution.

The main turret is of the hollow hexagon type, well proportioned and shown in Fig. 4 with bar tools mounted and ready for operation. The turret saddle has an exceptionally long bearing on the bed and the apron is similar to the one used on the cross slide. The drop off feed friction which

carriage apron. The taper attachment which is of rigid construction is mounted on the rear end of the carriage and operates directly on the cross feed nut. The adjustment of this attachment is very simple and requires only a minimum amount of time.

For automatic chuck and bar feed work, a chuck of the standard collet type may be furnished. This chuck has a short overhang beyond the front spindle bearing. A new method has been devised for operating the chuck wedge which not only makes the chuck easier to operate but increases its gripping power. The bar feed head travels on two parallel bars, the outer ends of which are supported in a rigid stand. Extensive and complete tool equipment for both bar and chucking work are designed for the Foster turret lathe. Fig. 1 shows a few special chucking tools mounted on the turret head, but Fig. 4 shows the ones most commonly used.

The machine can be driven either from a countershaft or by means of an individual motor, which is usually mounted on the back ledge of the machine where it will be out of the way. A special study has been made of the method

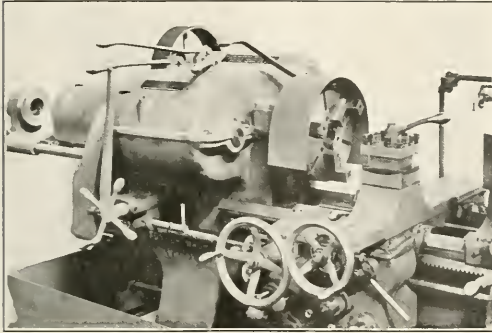

Fig. 2—Lathe Head, Cross Slide and Carriage

is automatically disengaged in a manner similar to that operating the feed friction for the carriage apron is here controlled by adjustable stops mounted on a long stop roll located between the ways of the bed. This stop roll is long enough to take care of work up to the maximum capacity of the machine.

An important feature is the quick traverse mechanism consisting of a right and left hand screw with engaging units mounted on the back of the lathe and operated by means of a lever from the front side. An adjustable rod, mounted on a bracket secured to the rear end of the bed,

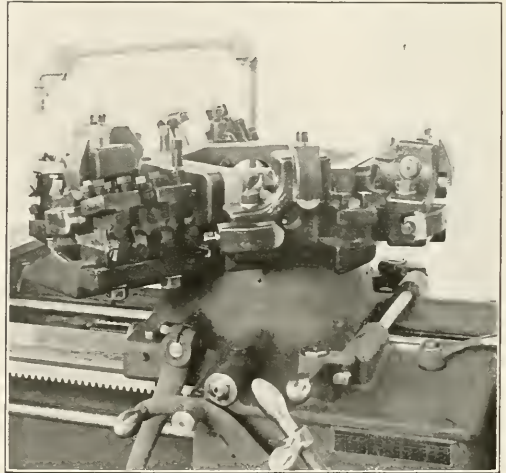

Fig. 4—Hexagon Turret and Saddle with Bar Tools

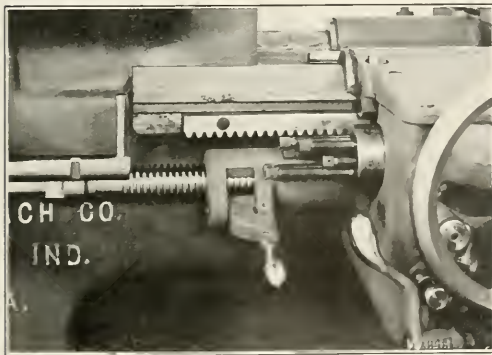

Fig. 3—Screw Cutting Attachment and Carriage Stops

automatically disengages the quick traverse and thus limits the movement of the saddle. The quick traverse screw is fully protected from chips and dirt and is driven by a belt from the main driving pulley.

If desired, the machine can be equipped with screw cutting and taper attachments. The screw cutting attachment plainly shown in Fig. 3 is mounted on the main feed rod and is capable of cutting two pitches of thread in the multiples of one and four of that of the pitch of the leader. The follower is mounted in a lever in a projection of the

of supplying the cooling compound and by means of a pump and pipes shown in Figs. 1 and 4, an ample supply is at all times available.

This lathe with automatic chuck and bar feed attachments weighs 5,200 lb.

GERMANY SELLS LOCOMOTIVES.—Despite the alleged deficiencies of the German railways in respect to rolling stock, Germany still finds it possible to manufacture locomotives for export, according to an Associated Press correspondent at Stockholm in a report dated March 25, and quoted in the New York Times. Two of an order of twenty for the Swedish State railways were received the first week in March, and the other eighteen were promised before April 1. The scarcity of brass and copper in Germany is evidenced by the fact that nearly all locomotive parts usually made of these metals are made of iron or steel in the locomotives already received. The Swedish State railways have also closed a contract with the German steel trust for 80,000 tons of rails, with plates and bolts. One-third of the order is to be delivered this year, a third is to be delivered in 1919, and the rest will be delivered in 1920.

Railway Mechanical Engineer

(Formerly the RAILWAY AGE GAZETTE, MECHANICAL EDITION
with which the AMERICAN ENGINEER was incorporated)

PUBLISHED ON THE FIRST THURSDAY OF EVERY MONTH BY THE
SIMMONS-BOARDMAN PUBLISHING COMPANY

EDWARD A. SIMMONS, *President* M. H. WIGM, *Secretary*
HENRY LEE, *Vice-President and Treasurer* L. B. SHEPMAN, *Vice-President*
WELLWORTH BUILDING, NEW YORK, N. Y.
H. H. SIMMONS, *Business Manager*, CHICAGO.

Chicago: Transportation Bldg. Cleveland: Citizens' Bldg.
Washington: Home Life Bldg.
London: Queen Anne's Chambers, Westminster.

ROY V. WRIGHT, *Editor*
R. E. TRAYER, *Managing Editor*
C. D. PECK, *Associate Editor* E. L. WOODWARD, *Associate Editor*
A. F. STUBBING, *Associate Editor* C. W. FOST, *Associate Editor*

Entered at the Post Office at New York, N. Y., as mail matter of the second class.

Subscriptions payable in advance and postage free: United States, Canada and Mexico, \$2.00 a year; Foreign Countries (excepting daily editions), \$3.00 a year; Single Copy, 20 cents.

WE GUARANTEE, that of this issue 10,000 copies were printed; that of these 10,000 copies 3,640 were mailed to regular paid subscribers, 138 were provided for counter and news companies' sales, 330 were mailed to advertisers, 169 were mailed to exchanges and correspondents, and 3,723 were provided for new subscriptions, samples, copies lost in the mail and office use; that the total copies printed this year to date were 49,400, an average of 8,233 copies a month.

The RAILWAY MECHANICAL ENGINEER is a member of the Associated Business Papers (A. B. P.) and of the Audit Bureau of Circulations (A. B. C.).

Colonel Wildurr Willing of the 12th Engineers (Railway) has acknowledged receipt under date of April 10, of two shipments of tobacco from the Railway Regiments' Tobacco Fund. He states that "This tobacco was divided among the enlisted personnel of the regiment, and I am sure the men have had no greater treat since entering the service of the government."

Employees of the Pennsylvania Railroad System in the military and naval service on April 1, last, numbered 12,348; and 8,415 of the names of these men are printed in a statement, filling 42 pages, of the Mutual Magazine, published by the employees of the Pennsylvania Railroad. This number of the magazine (May) has for its frontispiece a full length portrait of Brigadier-General W. W. Atterbury.

"Safe Practice" in the management of shafting, couplings, pulleys and gearing is the title of the National Safety Council's illustrated Pamphlet No. 8, which has recently been issued. It consists of eight pages, and the price is 10 cents. No. 9 deals with engine guarding and engine stops, automatic governors, etc., 16 pages; No. 10 is on oiling devices and oilers, eight pages. All of these are to be had from W. H. Cameron, general manager, National Safety Council, Chicago.

The locomotive boiler inspectors of the government will receive substantial increases of salary, if Congress accepts a report recently presented in the House by the Committee on Interstate and Foreign Commerce. By the bill as reported the chief inspector will be advanced from \$4,000 to \$5,000; two assistant chief inspectors from \$3,000 to \$4,000; and fifty district inspectors from \$1,800 to \$3,000. The report says that the legislative agents of the brotherhoods of enginemen, conductors and firemen, supported the bill.

The Division of Valuation of the Interstate Commerce Commission wants senior electrical engineers, grade 2; junior civil engineers, grade 1; and junior engineers in the same grade for the electrical, mechanical, signal, structural, telegraph and telephone departments; also junior architects. Candidates for senior electrical engineer will have their applications considered on June 18, while those for the other offices named will be taken up at any time, regardless of date. The salaries for the first named office will range from \$1,800 to \$2,700; and for the other places, from \$1,320 to \$1,680.

The New York legislature has passed a law requiring all new locomotives which shall be put in service after this year (1918) and all taken into the shop after January 1, next, for general repairs, to be equipped with "vestibuled" cabs, so constructed as "to attach to the sides of and inclose all openings between the engine cab and the tender." The New York law requiring power-operated fire doors on locomotives goes into effect on the same date on all new locomotives placed in service after January 1, next, and locomotives now in service must be equipped with vestibules the next time they are withdrawn for "generally vest repairs," after the act becomes effective next January.

Director General McAdoo has instructed that the order of the Interstate Commerce Commission which requires that locomotives be equipped with high power headlights be fully observed by all railroads. Some of the roads have been holding in abeyance the equipment of their locomotives with headlights to meet the requirements of this order, pending the outcome of court proceedings. The director general's instructions that the terms of the order be carried out in good faith means that all locomotives not now equipped with headlights to meet the requirements of rules 29 and 31 of the Interstate Commerce Commission will be so equipped as fast as locomotives are shopped for general repairs.

The University of Illinois, at its summer session, June 17 to August 9, will offer special advanced courses in the mechanics and properties of materials of construction and in materials testing, planned especially for instructors in mechanics, for chemists who wish to fit themselves to take positions involving the physical testing of materials, and for men who wish to fit themselves for positions in commercial or government testing laboratories. The extensive equipment of the Testing Laboratory of the University will be available for this work, which will be under the charge of Prof. H. F. Moore. Taken together, these courses will constitute a short course of intensive training for men who desire to qualify as testing engineers in the government service or elsewhere.

The Rock Island Lines plan to send a "smoke kit" to each of the 2,074 Rock Island men now in army and navy service. Ever since last summer money has been coming in for Company B, of the Thirteenth Engineers (Railways).

which has been in France since early last fall. So far about \$2,200 worth of "smokes" and other articles of comfort have been sent to the men in this company, and in addition \$2,275 has been cabled to the company as a mess fund. It is now proposed to send a kit containing tobacco, candy and other comforts to all other Rock Island men now with the colors. The May shipment to Company B cost \$461 and consisted of 12,000 Fatima cigarettes, 720 packages of Tuxedo tobacco, 864 packages of Prince Albert, 100 books of cigarette paper, 1,440 pieces of chewing tobacco, 10 dozen packages of pipe cleaners, 3,132 cigars, 180 lb. candy, 6,000 envelopes and 18,000 sheets of letter paper.

Canadian Orders for Cars and Engines

A statement of recent orders for equipment, presented in Parliament at Ottawa on April 9, by Hon. J. D. Reid, Minister of Railways, shows the following contracts:

Canada Car & Foundry Company, 5,000 forty-ton steel frame box cars, \$13,750,000; National Steel Car Company, 1,000 cars, \$2,750,000; Eastern Car Company, 750 forty-ton flat cars \$1,777,800; Eastern Car Company, 650 fifty-ton coal cars, \$2,066,675; Hart-Otis Company, 250 side-dump cars, \$760,000; Hart-Otis Company, 200 side and center-dump cars, \$625,000; Pressed Steel Car Company, 25 general service tanks, \$134,956; Pressed Steel Car Company, 25 water service tanks, \$129,593; Canada Car & Foundry Company, 250 refrigerator cars, \$1,024,250; Pullman Car Company, 14 sleeping cars, \$502,460; Pullman Car Company, 7 dining cars, \$238,700; Montreal Locomotive Works and Canada Locomotive Company, 50 Consolidation freight engines, \$2,900,000; 10 switching engines, \$405,000; 30 Pacific type engines, \$1,800,000; 60 Mikado type engines, \$3,720,000, Canada Locomotive Company, six switching engines, \$246,000; four narrow gauge engines, \$136,080. Total cost of all equipment ordered, \$32,966,515. This does not include the 100,000 tons of rails recently purchased.

In reply to a question, Dr. Reid said he might yet have to purchase ten or fifteen snow ploughs at a cost of \$100,000, while the National Railway Defense Association was asking him to buy 100 tourist cars for carrying troops. He might also have to purchase 19 baggage cars.

M. C. B. Circulars

The Executive Committee of the Master Car Builders' Association has issued circular No. 40 requesting that the placing of reporting marks on freight cars between two horizontal bars be considered as a standard of the association.

Circular No. 43 is a price list of the publications of the association. Copies of the Proceedings may be had at \$7.50 per copy, net. The Rules of Interchange are furnished at the following rates, to which postage should be added when sent by mail:

100 or more copies.....	\$4.00
50 copies.....	3.25
25 copies.....	2.00
Single copies.....	.10

The revised Loading Rules are sold at the following set prices:

100 or more copies.....	\$6.00
50 copies.....	3.25
25 copies.....	2.00
Single copies.....	.10

The revised Specifications for Tank Cars may be secured at the following net prices:

100 or more copies.....	\$7.50
50 copies.....	4.00
25 copies.....	2.00
Single copies.....	.10

A supply of the book containing the United States Safety Appliance requirements is still available at 25 cents per copy, I. O. B. Chicago. The supply of the bound volumes

of the decisions of the Arbitration Committee Cases 1 to 788, inclusive, is exhausted. A volume containing an abstract of Cases 1 to 942, inclusive, is available at 50 cents per copy, including postage if sent by mail. Cases 789 to 1132 are in pamphlet form, and are furnished free of charge.

The Car and Locomotive Orders

The United States Railroad Administration announced early in the month of May the placing of orders for 100,000 freight cars, to be built to its standard specifications, including 50,000 box cars, and 50,000 hopper and gondola coal cars, divided between 17 car building companies, and 1,025 locomotives also of its standard types, 555 from the American Locomotive Company and 470 from the Baldwin Locomotive Company.

The total cost of the cars is placed at from \$250,000,000 to \$300,000,000 and of the locomotives at approximately \$60,000,000, although the specialties have not yet been awarded and the final detailed contracts have not yet been executed. It is understood that 145 additional locomotives are to be awarded to the American Locomotive Company, and 30 to the Baldwin Locomotive Works, in about 60 days, and that approximately 1,000 additional locomotives and about 100,000 additional cars are to be ordered in about six months.

Cars.—The distribution of the order by companies and types is as follows:

American Car & Foundry Co.....	15,000 40-ton double sheathed box
	4,000 50-ton single sheathed box
	5,000 50-ton composite gondola
	4,000 55-ton hopper
Pressed Steel Car Co.....	6,500 50-ton composite gondola
	5,000 55-ton hopper
	2,500 70-ton low side gondola
Standard Steel Car Co.....	2,000 40-ton double sheathed box
	3,500 50-ton composite gondola
	3,000 55-ton hopper
	2,500 70-ton low side gondola
Pullman Co.....	6,000 50-ton single sheathed box
	2,000 55-ton hopper
Haskell & Barker Car Co.....	6,000 50-ton single sheathed box
	2,000 50-ton composite gondola
Ralston Steel Car Co.....	4,000 55-ton hopper
Cambria Steel Co.....	5,000 55-ton hopper
Magor Car Corporation.....	1,000 50-ton composite gondola
St. Louis Car Co.....	2,000 50-ton single sheathed box
Mt. Vernon Car Co.....	4,000 40-ton double sheathed box
Pacific Car & Foundry Co.....	2,000 40-ton double sheathed box
Liberty Car & Equipment Co.....	1,000 40-ton double sheathed box
Keith Car Mfg. Co.....	2,000 40-ton double sheathed box
Laconia Car Co.....	1,000 40-ton double sheathed box
Bettendorf Co.....	3,000 50-ton single sheathed box
Lenoir Car Works.....	2,000 40-ton double sheathed box
Barney & Smith Car Co. (pending).....	2,000 40-ton double sheathed box
Total.....	100,000

Locomotives.—The locomotive order was divided, 555 to the American Locomotive Company and 470 to the Baldwin Locomotive Works as follows:

American	Baldwin	Type
17	183	Light Mikado
70	30	Heavy Mikado
20	15	Light Mountain
3	2	Heavy Mountain
10	20	Light Pacific
16	10	Heavy Pacific
72	75	Light 2-10-2
25	10	Heavy 2-10-2
30	20	Six wheel switching
75	75	Eight-wheel switching
15	15	2-6-2 Mallet
5	15	2-8-2 Mallet

This order will be increased probably before July 1 to 1,200, the American Locomotive Company being given 145 more locomotives to make 700 locomotives, and the Baldwin Locomotive Works 30 more, to make 500.

Prices.—The car orders were all placed upon the basis of the minimum bids as to costs for labor and materials with the understanding that any reduction in costs which may be obtained from these fixed prices will be divided equally between the Railroad Administration and the car builders, but any increase in these costs will be borne exclusively by the builders. The government will have supervision, or control

as to the prices of the materials required in construction and in cases where the government has fixed prices these will be the maxima, but an effort is to be made to secure steel and other materials at prices below those previously fixed. In this case the builder will have an opportunity to share in the saving.

The compensation of the builders in the case of both cars and locomotives will be approximately 5 per cent on the cost, as estimated on the minimum bid. The contracts with the locomotive builders provide that the government guarantee the cost of material and that if any saving is made on the estimates other than that on the material, that it be divided equally between the government and the builders.

In the case of the locomotives, the announcement stated that deliveries are to begin in July and continue monthly during the remainder of the year, and in the case of the cars that it is hoped that the entire order will be completed in time for the fall and winter business of the railroads.

As this issue goes to press the orders for the specialties and appliances are being placed. One of the first distributions was that for draft gear, announced about June 3. The 100,000 cars are divided as follows: Sessions, 50,000; Westinghouse, 20,000; Cardwell, 15,000; Miner, 10,000, and Murray, 5,000.

M. C. B. and M. M. Associations

The Executive Committees of the Master Car Builders' and the Master Mechanics' Association, at a joint meeting held in Chicago on May 13, elected V. R. Hawthorne secretary of both associations, to fill temporarily the vacancy caused by the death of Joseph W. Taylor. Mr. Hawthorne was born at Oleona, Pa., on November 27, 1886. He entered the service of the Pennsylvania Railroad as a car repairman at the Elmira, N. Y., shops in June, 1905. He was transferred to the shops at Baltimore, Md., in November of the same year, at which place he was employed during the summer months repairing passenger cars and during the winter as a clerk. Here he gained his first experience in M. C. B. billing. In June, 1910, he was transferred to Williamsport, Pa., as M. C. B. clerk in the office of J. T. Wallis, remaining there until June, 1914, at which time he was transferred to Altoona, Pa., as a gang leader in the M. C. B. clearing house. While there he was appointed on the M. C. B. special committee making time studies. Early in 1917 he was appointed special master car building inspector, reporting to J. T. Wallis, general superintendent of motive power of the Pennsylvania Railroad. He was assigned on special M. C. B. committee work of the American Railway Association in April, 1917.



V. R. Hawthorne

MEETINGS AND CONVENTIONS

Society for Testing Materials.—The twenty-first annual meeting of the American Society for Testing Materials will be held at the Hotel Traymore, Atlantic City, N. J., on June 25, 26, 27 and 28. Wednesday afternoon, the 26th, will be devoted to topical discussions on Co-operation in

Industrial Research, while the evening session on Thursday will be a joint meeting with the American Concrete Institute. The annual golf tournament will be held on Thursday afternoon.

Western Railway Club.—At the annual meeting of the Western Railway Club held at the Hotel Sherman, Chicago, on May 20, the following officers were elected: President, A. LaMar, master mechanic, Pennsylvania Lines; first vice-president, G. S. Goodwin, mechanical engineer, Chicago, Rock Island & Pacific; second vice-president, W. Alexander, superintendent of motive power, Chicago, Milwaukee & St. Paul; treasurer, C. H. Bilty, mechanical engineer, Chicago, Milwaukee & St. Paul.

Master Car Builders' and Master Mechanics' Associations.—The Master Car Builders' Association and the American Railway Master Mechanics' Association has issued a joint circular postponing the annual conventions of the associations another year, and calling a meeting to dispose of the accumulated work of committees and to pass on other matters requiring action. All representative members, the chairmen of all committees, the executive committees of both associations, and the arbitration committee of the Master Car Builders' Association are invited to attend the meeting, which will be held in the Florentine Room of the Congress Hotel, Chicago, on June 19 and 20, 1918.

The Master Car Builders' Association will receive reports from the committees on the following subjects: Arbitration; standards and recommended practice; brake shoe and brake beam equipment; couplers; loading rules; car wheels; specifications and tests for materials; train lighting and equipment; tank cars, and welding truck side frames, bolsters and archbars.

Committees of the Master Mechanics' Association will present reports on the following subjects: Standards and recommended practice; mechanical stokers; fuel economy and smoke prevention; specifications and tests for materials; train resistance and tonnage rating; springs (shop manufacture and repair).

The reports of the committees will not be sent out to the members in advance of the meeting but copies will be distributed to those attending. The associations will maintain headquarters at the Congress Hotel. There will be no exhibit.

The following list gives names of secretaries, dates of next or regular meetings and places of meeting of mechanical associations:

- AIR BRAKE ASSOCIATION.**—F. M. Nellis, Room 3014, 165 Broadway, New York City.
- AMERICAN RAILROAD MASTER TINNERS', COPPERSMITHS' AND PIPEFITTERS' ASSOCIATION.**—O. E. Schlink, 485 W. Fifth St., Peru, Ind.
- AMERICAN RAILWAY MASTER MECHANICS' ASSOCIATION.**—V. R. Hawthorne, Karpen Bldg., Chicago. Meeting, June 19 and 20, Congress Hotel, Chicago.
- AMERICAN RAILWAY TOOL FOREMEN'S ASSOCIATION.**—R. D. Fletcher, Belt Railway, Chicago.
- AMERICAN SOCIETY FOR TESTING MATERIALS.**—Prof. E. Marburg, University of Pennsylvania, Philadelphia, Pa. Annual meeting June 25-28, 1918, Hotel Traymore, Atlantic City, N. J.
- AMERICAN SOCIETY OF MECHANICAL ENGINEERS.**—Calvin W. Rice, 29 W. Thirty-ninth St., New York.
- ASSOCIATION OF RAILWAY ELECTRICAL ENGINEERS.**—Joseph A. Andreuccetti, C. & N. W., Room 411, C. & N. W. Station, Chicago.
- CAR FOREMEN'S ASSOCIATION OF CHICAGO.**—Anton Kline, 841 Lawlor Ave., Chicago. Second Monday in month, except June, July and August, Hotel Mortenson, Chicago.
- CHIEF INTERCHANGING CAR INSPECTORS' AND CAR FOREMEN'S ASSOCIATION.**—W. R. McMunn, New York Central, Albany, N. Y.
- INTERNATIONAL RAILROAD MASTER BLACKSMITHS' ASSOCIATION.**—A. L. Woodworth, C. H. & D., Lima, Ohio.
- INTERNATIONAL RAILWAY GUILD ASSOCIATION.**—J. G. Crawford, 542 W. Jackson Blvd., Chicago.
- INTERNATIONAL RAILWAY GENERAL FOREMEN'S ASSOCIATION.**—William Hall, 1126 W. Broadway, Winona, Minn.
- MASTER BOILERMAKERS' ASSOCIATION.**—Harry D. Vought, 95 Liberty St., New York.
- MASTER CAR BUILDERS' ASSOCIATION.**—V. R. Hawthorne, Karpen Bldg., Chicago. Meeting, June 19 and 20, Congress Hotel, Chicago.
- MASTER CAR AND LOCOMOTIVE PAINTERS' ASSOCIATION OF U. S. AND CANADA.**—A. P. Dine, B. & M., Reading, Mass.
- NIAGARA FRONTIER CAR MEN'S ASSOCIATION.**—George A. J. Hochgrebe, 623 Brisbane Bldg., Buffalo, N. Y. Meetings, third Wednesday in month, Stabler Hotel, Buffalo, N. Y.
- RAILWAY STOREKEEPERS' ASSOCIATION.**—W. P. Murphy, Box C, Collinwood, Ohio.
- TRAVELING ENGINEERS' ASSOCIATION.**—W. O. Thompson, N. Y. C. R. R., Cleveland, Ohio. Next meeting, September 10, 1918, Chicago.

PERSONAL MENTION

GENERAL

J. BENZIES, supervisor of fuel economy of the Chicago terminal, Illinois and Missouri divisions of the Chicago, Rock Island & Pacific, with headquarters at Rock Island, Ill., now has charge of the Chicago terminal and the Illinois divisions, with the same headquarters. This change is due to a rearrangement of territories assigned to supervisors of fuel economy.

PAUL A. BEVAN, motive power inspector, Central System, Pennsylvania Railroad, Western Lines, has been granted a furlough to enter the Ordnance Department of the United States Army, as engineer of tests. Mr. Bevan is located at the United States Cartridge Company, Lowell, Mass.

E. W. SMITH, master mechanic of the Philadelphia division of the Pennsylvania Railroad, with office at Harrisburg, Pa., has been appointed superintendent of motive

power of the Central division to succeed Elliott Sumner, who has been transferred. Mr. Smith was born at Charlesburg, W. Va., on September 21, 1885. He is a graduate of the Virginia Polytechnic Institute, and he entered the service of the Pennsylvania Railroad on August 1, 1906, as a special apprentice. On July 26, 1909, he was made motive power inspector, was advanced to motive power foreman on September 1, 1912, and on October 15,

1913, he was appointed assistant master mechanic at the Altoona machine shops. On July 1, 1916, he was advanced to the position of assistant engineer of motive power in the office of the general superintendent of motive power at Altoona, which position he held until October 10, 1917, when he was appointed master mechanic of the Philadelphia division.

B. J. BONNER, road foreman of equipment of the Chicago, Rock Island & Pacific, with headquarters at Herington, Kan., has been appointed supervisor of fuel economy of the East Iowa, Cedar Rapids and Minnesota divisions, with headquarters at Cedar Rapids, Iowa.

F. CONNOLLY, supervisor of fuel economy of the St. Louis, Kansas City terminal, Kansas and El Paso divisions of the Chicago, Rock Island & Pacific, with headquarters at Herington, Kan., now has charge of the Kansas and El Paso divisions, with the same headquarters.

R. FERNANDEZ has been appointed locomotive inspector of the Cuba Railroad, with headquarters at Camaguey, Cuba.

E. S. FITZSIMMONS, mechanical superintendent of the Erie, with office at New York, has resigned to go into other business.

WILLIAM S. JACKSON, master mechanic of the Erie at

Marion, Ohio, has been appointed mechanical superintendent of the Erie, with headquarters at New York, to succeed F. S. Fitzsimmons. Mr. Jackson was born on August 12, 1878. He began railway work on August 16, 1892, with the Lake Shore & Michigan Southern and served to July, 1911, consecutively as engine dispatcher, roundhouse foreman and general foreman. He then went to the Interstate Commerce Commission as locomotive boiler inspector, and later was made locomotive inspector at Cleveland, Ohio, until January, 1917, when he entered the service of the Erie as general inspector. In August of the same year he became master mechanic of the Kent division at Marion, Ohio, which position he held at the time of his recent appointment as mechanical superintendent as above noted.

A. R. KIPP, mechanical superintendent of the Chicago division of the Minneapolis, St. Paul & Sault Ste. Marie, with headquarters at Fond du Lac, Wis., has been transferred to Minneapolis, Minn.

EUGENE McAULIFFE, president of the Union Colliery Company and formerly general coal agent of the Frisco Lines, has been appointed manager of the Fuel Conservation Section, Division of Transportation of the United States Railroad Administration, and will give attention to the conservation of fuel on all roads, with special reference to its preparation and proper use. He will also investigate and make recommendations in connection with its transportation to and handling at fuel stations; Major Edward C. Schmidt now with the Fuel Administration, has been appointed an assistant to Mr. McAuliffe, who will have headquarters both at Washington and at St. Louis.

F. MERLIDITH, supervisor of fuel economy of the Iowa, Nebraska and Colorado divisions of the Chicago, Rock Island & Pacific, with headquarters at Fairbury, Neb., now has charge of the West Iowa, Nebraska and Colorado divisions, with the same headquarters.

F. P. PFAHLER, master mechanic of the Baltimore & Ohio at Cumberland, Md., has been appointed mechanical engineer of the Locomotive Section, United States Railroad Administration.

H. S. WALL, whose appointment as mechanical superintendent of the Atchison, Topeka & Santa Fe, with headquarters at Los Angeles, Cal., was announced in the

Railway Mechanical Engineer for May, has been in the employ of the Atchison, Topeka & Santa Fe for a period of nearly 19 years. On October 5, 1899, Mr. Wall entered the services of that company as a machinist at Albuquerque, N. M., and on April 1, 1900, he was appointed round-house foreman at Needles, Cal. On July 1 of the same year he was promoted to general foreman at the same place, and on August 15, 1900, he was promoted

to division foreman at Barstow, Cal. He remained there until May 1, 1906, when he was promoted to master mechanic at Winslow, Ariz., being transferred on October 21 of the same year to Needles, Cal. On July 1, 1909, he became shop superintendent at San Bernardino, Cal., which



E. W. Smith



H. S. Wall

position he held until his recent appointment as mechanical superintendent of the Coast Lines as mentioned above.

C. W. REED, road foreman of equipment of the Chicago, Rock Island & Pacific, has been appointed supervisor of fuel economy of the Missouri, Kansas City terminal and St. Louis divisions, with headquarters at Trenton, Mo.

R. SANCHEZ has been appointed air brake instructor of the Cuba Railroad, with headquarters at Camaguey, Cuba.

E. C. SASSER, superintendent of motive power of the Southern Railway, with office at Charlotte, N. C., now has jurisdiction over the entire lines east; W. S. MURRIAN, having resigned to engage in other business, the position of superintendent of motive power of the middle district has been abolished.

P. SMITH, supervisor of fuel economy of the Cedar Rapids, Minnesota, Dakota and Des Moines divisions of the Chicago, Rock Island & Pacific, with headquarters at Cedar Rapids, Iowa, now has charge of the Dakota and Des Moines Valley divisions, with headquarters at Valley Junction, Iowa.

ELLIOT SUMNER, superintendent of motive power of the Central division of the Pennsylvania Railroad, with office at Williamsport, Pa., has been appointed superintendent of motive power of the New Jersey division, with headquarters at New York. Mr. Sumner succeeds F. G. Grimshaw, promoted.

MASTER MECHANICS AND ROAD FOREMEN OF ENGINES

G. H. BERRY has been appointed assistant master mechanic of the South Louisville (Ky.) shops of the Louisville & Nashville, succeeding B. E. Dupont, transferred.

C. H. BLAKE has been appointed road foreman of engines on the Southern Kansas division of the Atchison, Topeka & Santa Fe, with headquarters at Chanute, Kan., succeeding W. A. Moon, assigned to other duties.

R. V. BLOCKER, general foreman of the Erie at Huntington, Ind., has been appointed master mechanic, with office at Marion, Ohio, to succeed W. S. Jackson.

A. B. CLARK, master mechanic of the Chicago Great Western at Oelwein, Iowa, has been appointed master mechanic at Des Moines, Iowa.

C. W. CULVER, general foreman of the Central of New Jersey at Mauch Chunk, Pa., has been appointed assistant master mechanic of the Lehigh and Susquehanna division, with office at Mauch Chunk.

B. E. DUPONT has been appointed master mechanic of the Howell (Ind.) shops, Henderson and St. Louis divisions and St. Louis terminals of the Louisville & Nashville, succeeding Henry Hardie, deceased.

A. B. ENBODY, assistant master mechanic of the Central of New Jersey, with office at Mauch Chunk, Pa., has been appointed master mechanic of the Lehigh and Susquehanna division in charge of locomotive and car departments, and assignment of power, with office at Ashley, Pa.

C. GRIBBIN, master mechanic of the Canadian Pacific at North Bay, Ont., has been appointed master mechanic of the New Brunswick district, with office at St. John, N. B., succeeding C. Kyle, transferred.

T. HAMBLEY, division master mechanic of the Canadian Pacific at Sudbury, Ont., has been appointed master mechanic at North Bay, Ont., succeeding C. Gribbin.

S. W. HECKATHORNE has been appointed master mechanic of the Anthony & Northern, with headquarters at Pratt, Kan., succeeding S. C. Keep.

J. A. MCFERRAN, master mechanic of the Louisville & Nashville, at Covington, Ky., has been appointed master mechanic of the Mobile and Montgomery division and branches, with office at the Montgomery (Ala.) shop. The position of T. A. Nelson, assistant master mechanic at Montgomery, has been abolished.

C. W. MATTHEWS has been appointed master mechanic of the Cincinnati terminals and Kentucky division of the Louisville & Nashville, with offices at Central Covington (Ky.) shop, succeeding J. A. McFerran.

H. M. OAKES, formerly master mechanic of the Missouri, Kansas & Texas at Parsons, Kan., has been appointed master mechanic of the Chicago Great Western at Oelwein, Iowa, succeeding A. B. Clark.

F. W. OAKLEY has been appointed master mechanic of the Eastern Kentucky division of the Louisville & Nashville, with office at Ravenna (Ky.) shops, succeeding Harry S. Hills, deceased.

T. F. RYAN has been appointed assistant master mechanic of the Cincinnati terminals and Kentucky division of the Louisville & Nashville, with office at Central Covington (Ky.) shop.

T. R. STEWART, master mechanic of the Baltimore & Ohio at Connellsville, Pa., has been transferred as master mechanic to Cumberland, Md.

L. TEAGUE has been appointed acting master mechanic of the Cuba Railroad at Santiago, Cuba.

J. URSELLES has been appointed master mechanic of the Cuba Railroad at Camaguey, Cuba.

W. WELLS, district master mechanic of the Canadian Pacific, with office at Schreiber, Ont., has been transferred in the same capacity to the Farnham division of the Quebec district.

W. WRIGHT, division master mechanic of the Canadian Pacific, with office at Toronto, Ont., has been transferred as division master mechanic to Brownville Junction, Me., replacing C. Powers, who has been made division master mechanic at Toronto.

SHOP AND ENGINEHOUSE

J. S. ALLEN has been appointed general foreman of the locomotive erecting shop of the Canadian Pacific at North Bay, Ont.

F. W. FRITCHEY, of the Division of Locomotive Inspection, Interstate Commerce Commission, District 15, has been appointed superintendent of shops of the Wheeling & Lake Erie, with headquarters at Brewster, Ohio.

J. O. WAYCROFT, gang foreman of the Chicago Great Western at Oelwein, Iowa, has been promoted to day round-house foreman, succeeding Clifford Cade.

PURCHASING AND STOREKEEPING

C. C. KEEBLE, recently storekeeper of the Gulf, Colorado & Santa Fe, at Galveston, Tex., has received a commission as first lieutenant in the quartermaster's corps, at Washington.

M. C. MOLES has been appointed storekeeper of the St. Louis division of the Chicago, Rock Island & Pacific, with headquarters at St. Louis, Mo., succeeding F. E. Hartzler, who has enlisted in the 49th Regiment, U. S. Railway Engineers.

JOHN STAMMERS has been appointed storekeeper of the Kansas division of the Chicago, Rock Island & Pacific, at Herington, Kan., succeeding J. E. Thomas, resigned.

GEORGE G. YEOMANS, general purchasing agent of the New York, New Haven & Hartford, and G. W. Hayden,

assistant purchasing agent, now have supervision and management of both the purchasing and stores departments which were recently consolidated and are known as the supply department, with headquarters at New Haven, Conn. The supply agents, Lines East and West, will co-operate and rank with maintenance engineers and mechanical superintendents. The division supply agents will co-operate and rank with division master mechanics and division engineers.

OBITUARY

Stephen L. Bean, mechanical superintendent of the Atchison, Topeka & Santa Fe Coast Lines, died at Los Angeles, Cal., on March 24. He was born in Franklin county, N. Y., on March 26, 1854. He learned the machinist trade in the Manchester Locomotive Works and entered railway service with the Wisconsin Central in 1874. He was afterwards employed as machinist and foreman by the Chicago, St. Paul, Minneapolis & Omaha, at North Hudson, Wis., the St. Paul & Duluth at St. Paul, Minn., and the Northern Pacific. In February, 1881, he was made foreman of that road in charge of locomotives and equipment engaged in construction work in western North Dakota, which position he held until March 1, 1882. On that date he was appointed master mechanic at Glendive, Mont., was later transferred to Fargo, N. D., and from September 1, 1893, to November 1, 1902, he was master mechanic at Brainerd, Minn. On November 1, 1902, he was appointed shop superintendent of the Northern Pacific at Brainerd. Since June 10, 1903, he has been with the Atchison, Topeka & Santa Fe, originally as master mechanic at Albuquerque, N. M., and on April 20, 1904, was appointed mechanical superintendent of the Coast Lines, which position he held until the time of his death.

FRANK EICHER, who for many years previous to his retirement in 1912, held the position of general foreman of the coach yard of the Big Four at Cincinnati, died on April 2. Mr. Eicher had a record of 50 years continuous service with the Indianapolis & Cincinnati and its successor, the Big Four.

H. S. HILLS, master mechanic of the Louisville & Nashville, with office at Ravenna, Ky., died recently at his home in Irvine, Ky., at the age of 52.

A. E. HUTCHINSON, general purchasing agent of the Oregon Short Line, with headquarters at Salt Lake City, Utah, died in that city on April 3.

CHARLES D. PORTER, master mechanic of the Pennsylvania Railroad, at Pittsburgh, Pa., died in that city on May 2, at the age of 35.

HENRY RUSSELL LLOYD, fuel agent of the Chicago, Milwaukee & St. Paul until his retirement in 1910, died at his home in Chicago on April 12.

NEW SHOPS

FLORIDA EAST COAST.—This company is building a paint shop at St. Augustine, Fla., to cost about \$15,000. The structure is to have a wood frame with slate roof and will be one story high, 88 ft. wide and 100 ft. long. The work is being carried out by company forces.

PHILADELPHIA & READING.—A contract has been given to the William Steele & Sons Company, Philadelphia, Pa., for building a steel and concrete engine house at Philadelphia, part circular, and to contain 10 stalls 90 ft. long and 6 stalls 110 ft. long, also to build a machine shop of irregular shape. The latter will be 130 ft. wide at one end and 156 ft. 6 in. at the other by 216 ft. 7 in. long. The cost of the work will be about \$326,183.

SUPPLY TRADE NOTES

The Certes Supply Company, St. Louis, Mo., has been appointed selling agent for the Burden staybolt and engine bolt iron, and iron rivets in St. Louis and territory tributary thereto.

Thomas Finigan was elected a vice-president of the American Brake Shoe & Foundry Company, with headquarters at Chicago, at a meeting of the board of directors of that company on May 20.

McCord & Co., Chicago, have purchased several parcels of property in the vicinity of 112th and Green streets, Chicago. The property is adjacent to the company's present plant and will be used for future extensions.

H. D. Wright, manager of the San Francisco office of the Brown Hoisting Machinery Company, has been appointed Pacific coast representative, succeeding the Colby Engineering Company in the northwest territory. Mr. Wright's offices are in the Monadnock building.

The Southern Railway Supply & Equipment Company, St. Louis, Mo., announces the purchase of the car seat department of the Scarritt-Comstock Furniture Company, and the reorganization of that end of the business as the Scarritt Car Seat & Manufacturing Company.

George A. Post, Jr., western representative of the Standard Coupler Company, has received a commission as captain in the Ordnance Department. Mr. Post graduated from Cornell University in 1905, and has been connected with the railway supply field since graduation.

William F. Cutler has been elected president of the Southern Wheel Company, with headquarters at St. Louis, Mo., succeeding W. G. Pearce, who now becomes chairman of the board of directors; and Frank C. Turner was elected vice-president in charge of sales with office at St. Louis.

The Q & C Company announces that it has taken over the manufacture and sale of packing and lubricating under the Thomas Smith patents, formerly controlled by B. M. Jones & Co., of Boston. These devices will be hereafter known as the Q & C packing and Q & C lubricating.

R. G. Stutsman, for a number of years superintendent of the frog and switch shop of the Chicago, Milwaukee & St. Paul at Tomah, Wis., and more recently master mechanic of the Four Lakes Ordnance Company, Madison, Wis., has been appointed sales representative of Manning, Maxwell & Moore at Milwaukee, Wis.

J. M. Riordan until recently sales engineer of the Grant Lees Gear Company, of Cleveland, Ohio, and formerly representing the Fellows Gear Shaper Company, of Springfield, Vt., in the central states, is now connected with the sales organization of the Cleveland Milling Machine Company, 18511 Euclid avenue, Cleveland, Ohio.

Stephen C. Mason of the McConway & Torley Company, Pittsburgh, Pa., was elected president of the National Association of Manufacturers at a meeting of the board of directors held in New York, May 23, following the three-day convention. Mr. Mason is the seventh president of the association. He succeeds Colonel George Pope, who died April 19 last.

The property and plants of the Lehigh Foundry Company and the Lehigh Car, Wheel & Axle Works, of Fullerton, Pa., have been merged into one organization, the Fuller-Lehigh Company, with office and works at Fullerton, Pa. The properties of the two companies are adjoining and have been for a number of years under the same man-

agement. The change is one of name only. The executive personnel remains the same.

Press G. Kennett, Southern Railway sales manager for the Flint Varnish & Color Works, with headquarters at St. Louis, Mo., has been appointed western railway sales manager, with headquarters at Chicago, succeeding Rex W. Hudson, resigned to engage in other business. J. C. Jonas has been appointed southern railway sales manager at St. Louis, succeeding Mr. Kennett.

William Dewar Ellis, who was president of the Schenectady Locomotive Works when it was merged with the American Locomotive Company some years ago, died at his home in New York on May 23, aged 63 years. His father, John Ellis, was one of the founders of the Schenectady Locomotive Works, and Mr. Ellis succeeded his brother in the presidency of the corporation. He retired about fifteen years ago.

H. S. Patterson has been appointed manager of the railroad department of the Walworth Manufacturing Company, with headquarters in Boston, Mass.: H. T. Goodwin has been appointed assistant manager of the railroad department, with headquarters in New York. Both Mr. Patterson and Mr. Goodwin obtained their training with the National Tube Company by taking the specialty course at the Kewanee works of the National Tube Company, now the Walworth Manufacturing Company.

The Curtain Supply Company, owing to the growth of business and the need of increased space, has leased almost the entire building at 350-356 West Ontario street, Chicago, and has been located there since June 1. The new quarters of the company will be about 50 per cent larger than the old. The building is new and in addition to being equipped with greater and more efficient manufacturing facilities, will have a private track for shipping and receiving freight. For about 19 years this company has been located at 320 West Ohio street, Chicago.

Edward Buker has been appointed western representative of Rome Iron Mills, Inc., with office in the McCormick building, Chicago. Mr. Buker was born in Chicago in 1885. He received his education in the public schools of that city and at the University of Illinois, from which institution he received the degree of Mechanical Engineer. While at college his summer vacations were spent in the South Chicago rolling mills. Immediately upon graduation from college Mr. Buker entered the service of the Pullman Company as apprentice in that company's car shops in Chicago. After serving his time he went as special apprentice in the locomotive shops of the Illinois Central. Two years later he accepted a position as inspector on the Chicago, Rock Island & Pacific and was later appointed general foreman on the same road. Leaving the Rock Island he went with the Missouri, Kansas & Texas as master mechanic. During the past two years he has been with the Galena-Signal Oil Company as mechanical expert, which position he held up to the time of his recent appointment.



E. Buker

The Ohio Electric & Controller Co., 5900 Maurice avenue, Cleveland, Ohio, has been incorporated with a capital stock of \$200,000 for the purpose of manufacturing lifting magnets and electrical controlling devices. Lifting magnets will be built at once and controlling devices later. The officers of the new company include I. W. Jessop, president; W. B. Greene, vice-president, and A. D. Walter, secretary and treasurer. Mr. Jessop was formerly works manager of the Electric Controller & Manufacturing Company, Cleveland. He has had an extensive experience in the manufacture of lifting magnets and electrical apparatus for the control of motors.

Holmes Forsyth, second vice-president, secretary and general manager of the Curtain Supply Company, Chicago, was elected president at a meeting of the directors on April 30. Randolph S. Reynolds, assistant to the general manager, was elected secretary to succeed Mr. Forsyth.

Mr. Forsyth has been actively connected with the Curtain Supply Company since its organization in 1899, having at that time been elected second vice-president and secretary of the company, which offices he continued to hold until his recent election as president, succeeding Edward T. Burrows, who died on March 19, at his home in Portland, Me.



H. Forsyth

Mr. Burrows had been the president of the company since its organization on May 19, 1899, at which time the E. T. Burrows Company, the Adams & Westlake Company, and the Forsyth Brothers Company, sold out their curtain departments to the new concern which was designated the Curtain Supply Company. Mr. Burrows was therefore connected with the car curtain industry from its very beginning, being president of the first company that ever put on the market an American car window curtain.

Mr. Reynolds has been with the Curtain Supply Company since 1912. Prior to that date he was with the Western Steel Car & Foundry Company, at Anniston, Ala., and with the Pressed Steel Car Company, of Pittsburgh, Pa., having been connected with their purchasing department from 1905 to 1912, at which time he resigned to go with the Curtain Supply Company.

At a meeting of the stockholders of the Joseph Dixon Crucible Company, held on April 15, the following were elected officers of the company: George T. Smith, president; George E. Long, vice-president; J. H. Schermerhorn, vice-president; Harry Dailey, secretary; William Kcester, treasurer, and Albert Norris, assistant secretary and assistant treasurer. The American Graphite Company, a subsidiary of the Joseph Dixon Crucible Company, held its annual meeting on the same day. George T. Smith and George E. Long were also elected president and vice-president, respectively, of this company; J. H. Schermerhorn, treasurer, and Harry Dailey, secretary.

Frank Hopewell, head of the firm of L. C. Chase & Co., Boston, Mass., died April 25, at the age of 61. Mr. Hopewell was born in Shelburne Falls, Mass., in 1857. His father, a native of London, England, came to the United

States at the age of 14 and settled in Springfield, Mass., where his son, Frank, graduated from the Springfield High School in 1875, and the Springfield Collegiate Institute in 1879. In 1881, Frank Hopewell became associated with L. C. Chase & Co., of Boston, selling agents for Sanford Mills, Troy Blanket Mills, Reading Rubber Manufacturing Company, and Holyoke Plush Company, becoming a partner in 1887. He became treasurer of Sanford Mills in 1896, holding this office until 1915.

Lieut. Colonel W. R. Roberts, announcement of whose promotion from Major to Lieut. Colonel in the Construction Division of the United States Army was made last month, is president of Roberts & Schaefer Company, Chicago. Colonel Roberts has been in engineering construction work for 30 years, and about 20 years ago organized the Roberts & Schaefer Company, which specializes in coal mining plants, coal washeries, coal docks, etc. He is still president of this company, although he has been giving all of his service to the government since last October. The Construction Division of the Army, with which Colonel Roberts is connected, is the outgrowth of the old Cantonment Division which was organized for the purpose of building the 16 National Army camps and the 16 National Guard camps. The variety and character of the work of the Construction Division are much greater than were those of the old Cantonment Division. While the Construction Division is still building some cantonments for the Signal Corps and the Engineer Corps and making extensive additions to all the original cantonments, its most important work at present is the building of large ordnance plants, powder manufacturing plants, Quartermaster Corps, terminals, Quartermaster interior depots, many large hospitals, etc. Indeed, this division does all the construction work for the United States and its possessions, for all divisions or bureaus of the Army, and it now has a construction program on hand which amounts to about \$650,000,000. It is divided into six branches, engineering, construction, materials and transportation, contract and administration. Colonel Roberts is executive officer in charge of the construction branch, which is the largest and most important branch and which now employs about 200,000 men. Colonel Roberts was a graduate of the University of Illinois. His success in his business, as well as in his new work, has been due not only to his skill as an engineer, but to his ability as a business organizer.



Lieut. Col. Roberts

Independent Pneumatic Tool Company

A re-organization has been effected of the Independent Pneumatic Tool Company, a New Jersey corporation, and the Aurora Automatic Machinery Company, which is incorporated in Delaware. Both companies were owned by the same interests, the Independent Pneumatic Tool Company, representing the selling division for the Thor pneumatic and electric tools, and the Aurora Automatic Machinery Company being the manufacturing department. The latter company also manufactures and sells Thor motorcycles and gasoline engines.

The combining of the two companies under one corporate name is for convenience in handling business.

Under the re-organization plans the company is known as the Independent Pneumatic Tool Company, incorporated in Delaware for \$3,000,000. Ten directors will serve on the board as follows: John P. Hopkins, former mayor of Chicago, chairman; John D. Hurley, James J. McCarthy, William A. Libkeman, Leonard S. Florsheim, Edward G. Gustafson, Robert T. Scott, Ralph S. Cooper, August Gatzert and Fletcher W. Buchanan.

The officers are John D. Hurley, president; Ralph S. Cooper, vice-president; Fletcher W. Buchanan, secretary and Edward G. Gustafson, treasurer.

The general offices of the company are in the Thor building, at 1307 South Michigan boulevard, Chicago.

Chicago Pneumatic Tool Company

The following changes in the organization of the manufacturing and sales departments of the Chicago Pneumatic Tool Company have been effected by H. A. Jackson, the company's new president: W. H. Callan, manager of the company's two compressor plants at Franklin, Pa., has been appointed general manager of plants, with headquarters in Chicago. W. P. Pressinger, manager of the compressor and engine departments at Chicago, has been appointed general manager of sales, with the same headquarters. H. D. Megary, previously with the Bethlehem Steel Company, South Bethlehem, Pa., has been made assistant to the president at Chicago. G. A. Rees, general purchasing agent, has been promoted to manager of purchases and stores at Chicago. These officers report directly to the president.



W. P. Pressinger

In addition, the following changes have been made in the sales department. These officers, most of whom formerly reported directly to the president, will hereafter report to the general manager of sales and will constitute his staff: J. C. Osgood, manager of the pneumatic tool sales division; C. B. Coates, manager of the electric tool sales division; H. L. Dean, manager of compressor sales division, formerly assistant manager of the compressor department at New York; B. R. Hawley, manager of engine sales division, formerly assistant manager of the engine department at Chicago; T. J. Hudson, manager of the motor truck sales division. All of these men will have headquarters in Chicago. The above appointments were effective May 27.

W. P. Pressinger, who has been promoted to general manager of sales, was born in New York City on September 27, 1871. In 1887, he entered the employ of the Clayton Air Compressor Works, New York. He remained with that company for 13 years, rising to the position of manager of sales. In 1900 Mr. Pressinger organized the New York Air Compressor Company of which corporation he was secretary and general manager. In the following year the company was assimilated by the Chicago Pneumatic Tool Company. Mr. Pressinger was manager of the compressor department of that company up to the time of his appointment as general manager of sales, as aforementioned. He is also president of the Compressed Air Society.

CATALOGUES

RED CROSS CIRCULAR.—E. S. Jackman & Co., Chicago agents for the Firth-Sterling Steel Company, are sending out an attractive folder prepared by Edwin S. Jackman in the interests of the American Red Cross.

VALVE GEAR.—"The Baker Locomotive Valve Gear" is the title of a booklet issued by the Pilliod Company, Swanton, Ohio, describing the locomotive valve gear of that name. Definitions are given of the various valve terms and the principle of operation, together with a description of the method of valve setting.

SMOOTH-ON IRON CEMENT.—The sixteenth edition of the "Smooth-On" instruction booklet, issued by the Smooth-On Manufacturing Company, Jersey City, N. J., contains 144 pages, each one with an illustration showing in an interesting manner how the different "Smooth-On" iron cements are used for repairing purposes.

SMALL TOOLS.—The small tools department of the Pratt & Whitney Company, Hartford, Conn., has issued catalogue No. 9 covering the taps, dies, milling cutters, reamers, punches, drills, etc., manufactured by that company. The catalogue has 315 pages, 4½ in. by 7½ in. and in the miscellaneous section in the back there are several valuable tables.

TOOLS.—The Warren Tool & Forge Company, Warren, Ohio, has issued a 32-page catalogue, illustrating and indexing the special line of hand tools manufactured by that company. These consist of picks, crow bars, lining bars, various heavy hammers, axes, rail and tie tongs, wrenches, chisels, etc. Many different forms of each tool are illustrated.

DRIVING BOX LUBRICATION.—The Franklin Railway Supply Company, Inc., New York, has issued bulletin No. 500 describing the Franklin automatic driving box lubricator. Instructions are given for applying the lubricator, also for its proper inspection and care, and in connection with the lubricator, a special method of grooving the brasses is described and recommended.

BALANCED DRAFT.—The Engineer Company of New York has issued bulletin 16 entitled "Balanced Draft," giving an analysis of combustion conditions and boiler operation when nearly atmospheric pressure is maintained in the furnace chamber. Bulletin No. 18 issued by the same company explains in detail the advantages of balanced draft and describes the apparatus necessary to maintain it.

KEYSTONE QUALITY.—The Keystone Manufacturing Company, Buffalo, N. Y., has issued a 40-page booklet describing and illustrating the line of ratchets for both drills and wrenches manufactured by that company. Prices and dimensions for ratchets designed for various purposes are shown as well as the auxiliary parts used. Several pages are devoted to cataloging the various styles of Westcott adjustable S-wrenches.

BOILER METERS.—In bulletin No. 41, issued by the Bailey Meter Company, Boston, Mass., and entitled "How to Save Coal," there is considerable useful information regarding boiler capacity, efficiency and the amount of air necessary for complete combustion. Bailey meters give continuous records of steam flow, air flow and temperature variations, and this bulletin points out the necessity of such records for efficient boiler operation.

TRUCK BATTERY CHARGING.—Publication No. 234, issued by the Cutler-Hammer Manufacturing Company, Milwaukee,

Wis., is a six-page illustrated folder describing the C-II sectional battery charging equipment for industrial electric trucks, which has been extensively used in public and private garages. Two pages are devoted to illustrating a number of large and small equipments in industrial establishments, piers and railroad terminals.

AN INVESTIGATION OF PIPE CORROSION.—This is the title of Bulletin No. 30, issued by the A. M. Byers Company, Pittsburgh, Pa. The investigation was prompted by local agitation on the part of property owners in Pittsburgh, due to the difficulty of maintaining hot water pipe lines. It involved an investigation of the condition of hot water pipes in 125 apartment buildings in the city of Pittsburgh, and the data is arranged to show a comparison of the life of wrought iron and steel pipes.

PUMPS FOR CUTTING COMPOUND.—The Fullro Pump Company, Cincinnati, Ohio, has recently issued a bulletin describing the impeller type of pump for the distribution of coolant which this company manufactures. It has also prepared for free distribution a booklet entitled "The Scientific Lubrication of Cutting Tools." This booklet gives a short history of cutting tool lubrication and describes the methods of application of cooling compounds which have been found most effective in increasing the life of tools.

INDUSTRIAL LIGHTING.—The importance of proper lighting as an aid in securing the maximum production in the shops is well brought out in a booklet published by the Cooper-Hewitt Electric Company, Hoboken, N. J., under the title, "Lighting for Production and Safety." The intensity of illumination, system to be used, character of light source and units, are discussed and the application of the principles set forth is illustrated by several drawings showing typical lighting arrangements as installed in various manufacturing plants.

PACKINGS AND MECHANICAL RUBBER GOODS.—Jones Packings is the title of a 28-page catalogue which has been issued by the Jones Packing Company, 50 Church street, New York. A complete line of fibrous packings for oil, ammonia, steam, acid, water, syrup, air, alkali, etc., is illustrated and briefly described, with price quotations. The line includes ring, spiral and coil packings of various sections and types of construction; sheet packing; asbestos, duck insertion and tubular gaskets; pump valves, water and steam hose; diaphragms, etc.

"MY DEAR JIM."—This is the title of a small booklet issued by the Carnegie Steel Company in the form of a letter from a retired steel man to a friend in Medicine Hat. The letter tells in entertaining language of the growth of the Carnegie Steel Company during the last 20 or more years, both as to the extent of its plants and the variety of its products. Following the general outline of the latest Carnegie Shape Book, detailed information is given concerning the various sections rolled for structural and industrial purposes, giving the trade reasons for introducing the newer sections.

STONE-FRANKLIN LIGHTING EQUIPMENT is the title of an instruction book and part catalogue just issued by the Franklin Railway Supply Company, Inc., 30 Church street, New York. The first part of the book contains illustrations and wiring diagrams of the different types of Stone-Franklin car lighting equipment. Following this there is given information pertaining to terminal inspection, some condensed maintenance information, instructions for the application of generators and detailed statements of the principal features to be observed in operating and maintaining the equipment. The latter part of the book is given over to a complete list of parts. Cross-section drawings of the generators show exactly where these parts are located. The book contains many illustrations and will be found to be of much value to all users of Stone-Franklin lighting equipment.

Railway Mechanical Engineer

Volume 92

July, 1918

No. 7

CONTENTS

EDITORIALS:

Air Brake Conditions Demand Attention.....	377
An Impetus to Safety First.....	377
Spraying Method of Painting.....	378
Changing Freight Car Wheels.....	378
Apprentice Training During the War.....	378
Conservation of Labor.....	378
Better Supervision of Equipment Repairs.....	379
Wheel Arrangement and Rail Stresses.....	379
New Books.....	380

GENERAL:

Reclamation on the Southern Pacific.....	381
Distribution of Standard Locomotives to the Railroads.....	386
W. S. S. Nursery Rhyme.....	386
Drafting Modern Locomotives.....	387
The Meaning of W. S. S.....	392
Railroad Administration Activities.....	393
The Car and Locomotive Specialty Orders.....	395
An Unusual Boiler Explosion.....	396

CAR DEPARTMENT:

British Ambulance Train for American Wounded.....	397
A Statement of the Purpose of the M. C. B. Association.....	398
Passenger Car Terminal Repairs.....	400
Steel Frame Refrigerator Cars.....	401
Freight Brake Maintenance.....	406

SHOP PRACTICE:

"The Real Test Is to Get Results".....	409
Injector Gage.....	410
A Traveling Anti-Waste Exhibit.....	410
Piece Work System in Railway Shops.....	411
Metallic Electrode Arc Welds.....	416
Heat Treatment of Axles.....	419
Spring Stripping Machine.....	421
The Losses in a Small Power Plant.....	422
Babbitt Separator.....	422

NEW DEVICES:

System for Preparing Journal Box Packing.....	423
Baker Rod Drill.....	423
New Type of Machine for Wood Working.....	424
Anderson Valve Gear.....	424
Track Box Lubricator.....	425
Extension Boring Mill.....	426
Sta-Rite Uncoupling Lever Attachment.....	426

GENERAL NEWS:

Notes.....	427
Meetings and Conventions.....	428
Personal Mention.....	429
Supply Trade Notes.....	430
Catalogues.....	432

Air Brake Conditions Demand Attention

The majority of men in the mechanical department apparently do not realize the condition of air brakes on freight cars. The general air brake inspector of a road that is noted for its good maintenance said recently: "If the present conditions prevail for another year it will be impossible to handle trains without the use of hand brakes. I know of a case where out of 48 cars the air brakes on 22 cars would not apply with an emergency application." Surely, such statements coming from a man who knows the actual conditions, furnish sufficient proof that the maintenance of air brakes demands immediate attention.

During the summer the air brakes give less trouble than during cold weather. Examine the cars in a train ready to start from the yard and you are certain to find reservoirs loose on the brackets, causing leaks in the piping, porous hose, brakes cut out and brakes that leak off, due to faulty packing leathers or other causes. The car inspector may be able to get the train out and the engineer may be able to operate it properly under favorable conditions, but when frozen hose causes leaks at the couplings and the air compressor and the locomotive are both overburdened such defects lead to costly delays on the road, and in extreme cases may cause wrecks.

The only way to get the brakes in condition for next winter is to start a vigorous campaign at once. Every car that comes into the shop should have its brakes put in thoroughly operative condition before it is allowed to go into service. The men in charge should see that the employees who do the air brake work on repair tracks are competent to handle it properly. At some of the principal yards dead lines should be established and no cars should be allowed to pass those points unless the air brakes are in operative condition. Train-

men should be taught to make use of M. C. B. standard air brake defect card, which is of great assistance to car men when making repairs.

To keep the air brake in good condition requires a considerable expenditure for maintenance. This expense is necessary for safe operation and no mechanical officer should hesitate to employ a force large enough to keep the brakes up to a high standard of efficiency. If the provision of the safety appliance act requiring that all freight trains should have air brakes on 85 per cent of the cars in operative condition had been strictly enforced last winter, many terminals would have been tied up. The roads must either do a great deal of air brake work during this summer or they must prepare to resort to the use of the hand brake next winter.

An Impetus to Safety First

"Safety First" has been so widely advertised by the railroads that it has become a common and almost hackneyed expression. The remarkable work that has been done on many roads has been widely heralded and commended. The general principles upon which the best managed safety first campaigns have been based have proved so efficacious that they have been applied with good results to campaigns for improved practices in other directions. That many railroads, or possibly the average railroad, have not fully awakened to their responsibilities (or privileges) in the safety first movement is indicated by the fact that the Railroad Administration, after investigation, has found it necessary to recommend for general adoption those methods which have been found most successful by the roads which are leaders in the safety first movement. To make the move-

ment a real success it will be necessary not only to install the right form or organization, but to put the real spirit into it and everlastingly keep at it. On those roads where the movement has been the greatest success the personality of some one man—or possibly several—has been behind the movement and has not only unceasingly hammered it home, but in such a way as to keep the interest of the employees at a high point all the time. It is important, therefore, that the right kind of a man be selected to head up the movement on each road, and at each point on each road. This is really of far greater importance than the form of organization, important as is the latter.

Spraying Method of Painting

The problem of proper protection of equipment by painting has become a very important one. With the demand for equipment as great as it is at the present time, the painting department is at a disadvantage in that it cannot get the equipment into the shop when it wants it and when once there it must be hurried through in order to get it back into active service. Every means, therefore, must be taken to speed up the work and at the same time have it properly done. The spraying system of painting has been used on several roads. By this method the equipment can be given ample protection, the work done in a much shorter time and many places inaccessible for brush painting can be reached. The chief criticism made of this system is that more paint is required to do a given piece of work than if it were painted by hand. This perhaps is true in cases where it is impossible to regulate the width of the spray as is the case in most home-made spraying outfits. But with an adjustable tip to the nozzle this objection can be overcome to a large extent, except where small surfaces are to be painted.

Even with these objections the saving in labor and the speed with which the work is done will offset the extravagance in the use of the paint materials. Where this method of painting is used indoors or in confined places, some means must be provided to clear the atmosphere of the paint fumes for the protection of the health of the operators. Where it is used in the open, however, it will be found that such precautions are not necessary.

Changing Freight Car Wheels

Last winter was productive of many unusual conditions in the operation and maintenance of equipment. One of these, which was exceedingly troublesome and serious in its consequences, was an epidemic of truck failures on freight cars. No doubt there are several causes to which this may in part be attributed, but it seems probable that the underlying cause was a lowering of the standard of wheel maintenance.

Under the stress of a shortage of car repairers and difficult working conditions, such as existed last winter, a tendency to overlook certain repairs may be expected. A high standard of maintenance is so essential in few other details, however, as in the changing of wheels. Defective wheels are not only dangerous in themselves, but may be productive of much damage to the whole truck structure, resulting in failures which may have disastrous consequences in the loss of life and property.

During the past year, the average weight of all car load freight and the amount of freight moving in full capacity car loads have both increased. Furthermore, in many cases there has been a reduction in the standard of track maintenance brought about by war conditions. It is clear, therefore, that a high standard of wheel maintenance is more essential than ever before. Whenever cars reach the repair track the wheels should be replaced even a little before the

M. C. B. limits have been exceeded rather than allowed to remain in service with the probability of exceeding the limits before another opportunity for replacement has presented itself.

Apprentice Training During the War

The loss of skilled mechanics since this country entered the war has created a serious situation in the railroad shops. On practically every road it is found that the average production of the workers has fallen off very markedly, due in a great measure to the large labor turnover. Probably no individual roads have suffered more through the loss of men from the shops than the roads that have maintained apprentice courses. Many of their best mechanics were comparatively young men who left the service to join the colors. The training of apprentices in railroad shops seems to have suffered a setback due to these unfortunate circumstances. It is discouraging to see the men who have received the apprentice training leave the service in such large numbers. Apprentices cannot be trained to fill the gaps in the ranks and specialized training is necessary to develop skilled machine operators in the shortest possible time. The roads that had well organized apprentice schools, however, found that they possessed an organization admirably suited for instructing new men, and these roads are to be commended for training the men they needed instead of merely luring them away from other shops.

Before the war apprentice training courses proved their value in developing the all-round mechanics necessary to maintain a flexible organization; during the war they have enabled the roads to cope with the serious labor situation. A consideration of the present conditions will convince anyone that an apprentice course will aid materially in meeting the situation that will arise after the war. There will be a great demand for mechanics who must replace what has been destroyed and make up for what has been left undone during the war. The railroads will have a tremendous task in bringing their neglected equipment up to the former high standards. Despite the difficulty of securing boys who will develop into mechanics, and in spite of the discouragement of seeing many of them leave soon after their training is finished, the roads should continue their apprentice courses in order to fill the depleted ranks of all-around railroad mechanics and to provide a class of men from whom the foremen of the future can be developed.

Conservation of Labor

The writer took occasion a few days ago to visit a manufacturing plant in the vicinity of New York City. A variety of work was being done, including the building of a highly developed special machine which required the most accurate workmanship and a variety of special jobs, most of them for use in war work and requiring great accuracy. The special jobs were in addition to the regular work for which the plant had been designed. The question that immediately came to mind was how it was possible to maintain a sufficient force of skilled mechanics to meet the demands for the increased output which was being required. Inquiry developed the fact that careful planning and adequate supervision had made it possible greatly to increase the output per worker in such a way that the workers were well satisfied. Many skilled men had left to join the colors, but this shortage had been largely overcome by using women workers for those classes of work for which they were best fitted. Not the least of the incentives to good work and greater output was a profit sharing plan. The plant manager, who was largely responsible for the improvement, was a railroad man, having served his time and received his early training as a machinist in a railroad shop.

Railroad shop managers are prone to argue that manufacturing and railroad repair shop conditions are so different that they are not comparable and that locomotive repair work, for instance, must be handled entirely differently from work in the average manufacturing establishment. It is true that there may not be as much routine work in a repair shop as in a manufacturing shop; it is true also that the size and weight of locomotive parts may require very different handling from the building of a machine tool; a higher degree of skill, however, is required to secure the greater accuracy which is necessary in the latter. The boiler shop and the erecting shop are hardly places for women workers, but there are many jobs in a railroad repair shop which can be performed quite acceptably by women workers, allowing the men to be transferred to the heavier work. In both the manufacturing shop and the railroad repair shop, however, the general principles governing the organization and the handling of the employees are much the same. Not a few railroad shop managers have failed to realize this and not only have they not examined and studied the best practices in industrial shops but they have not even availed themselves of the best practices in their own field. A point in question is shop scheduling in locomotive repair shops. Many, many times we have described such a system in these columns and have clearly and fully told of its advantages—and yet how slowly the practice has spread. Again, how many railroad shops are there which have really adequate apprenticeship systems; or how many railroads have done anything really worth while in making working conditions convenient and attractive for employees? Is it any wonder that factories of modern construction, headed by managers with a real vision of the labor problem, can attract men from many of our railroad shops?

Better Supervision of Equipment Repairs

There never was a time in railroad history when adequate supervision was so badly needed in the mechanical department as at present. The shortage of skilled labor which is already being felt, and which is likely to become more acute before a thorough stabilization of labor conditions is affected, is proving a serious handicap to the mechanical department in meeting the need for more and better repairs to equipment which the transportation industry feels so keenly today. While statistics may not show an acute shortage in the number of shop employees, the general readjustment of labor which has taken place during the past year has left the railroads with a much lowered standard of skill and efficiency of their shop employees. This has all the effect in decreased output and poor workmanship which would follow an actual reduction in the number of men employed under normal conditions.

That there can be much direct relief from this situation during the course of the war is extremely doubtful. The general exodus of skilled workers from the railroad ranks can and probably will be checked by wage readjustments, but in a large measure, the damage has already been done and, indeed, is only in keeping with the general labor stringency in all industries. The heavy overload which our transportation system must bear, however, permits of no lowering of maintenance standards or a decrease in output, and if the situation cannot be overcome directly, at least its effect must be neutralized. This can only be done through closer and better supervision. There must be no shortage of able foremen.

There has long been considerable difficulty in selecting and keeping a sufficient number of shop and roundhouse foremen, because the salaries paid these men have not been sufficient to attract the brighter and more capable men from the ranks. This situation has gradually been growing more acute during the past few years. Data compiled by the Rail-

road Wage Commission indicate that the average monthly compensation of the general foreman in the mechanical department has increased from \$127.77 in 1915 to \$137.73 in 1916. The average earnings per month of gang and other foremen were \$97.24 in 1915, and \$112.76 in 1917. Machinists earned on an average of \$85.87 in 1915 and their average monthly earnings increased to \$116.35 in 1917. The average monthly earnings of boilermakers increased from \$89.68 in 1915 to \$118.85 in 1917, and these figures tell only part of the story, as the brighter and more skilled men, working overtime or on a piece-work basis, actually earned much more than these averages. Why should a capable mechanic accept a position as foreman when he must do so at an actual loss of income, which, even with better than the average success in winning promotion, it will require years to overcome? Why should he give up comfortable working conditions to assume the heavy load of responsibility and the steady grind of long hours with almost no time that he can call his own?

Under the sliding scale of percentage increases recommended by the Railroad Wage Commission and put into effect by general Order No. 27 of the Director General of Railroads, these conditions are only aggravated, because while the average wage of the mechanic is greater than that of the lower grades of foremen, these earnings are made up of a standard wage at a base rate, to which is added pay for overtime, often at the rate of time and one-half time, or a substantial increase for piece work, while the earnings of the foremen are fixed absolutely by the base rate. Under these conditions, the increase which the foreman receives under Order No. 27, is not only a smaller percentage, but actually smaller in amount than that received by the mechanic. It would be hard to justify this situation on any grounds, and under the stress of present conditions it is intolerable.

Much has been said as to the needs of labor and too much care cannot be taken to insure that the great army of railroad workers receives full justice in any question of wages or conditions of employment that may arise. The fact must not be overlooked, however, that the effectiveness of any army depends largely upon the quality of its leadership, and there has never been a time when a higher quality of leadership was demanded in the motive power department than now. The situation, therefore, demands that there be an entire readjustment of the relation of the salaries of the lower supervising officers to the wages of mechanics in the motive power department.

Wheel Arrangement and Rail Stresses

The American Railway Engineering Association and the American Society of Civil Engineers have recently done some work that is of great value to locomotive designers. The report of the committee on stresses in railroad track presented at the A. R. E. A. convention in March contains data that will make it possible to design locomotives on a more scientific basis, to take advantage of the maximum capacity of the track without producing undue stresses in the rail.

It has long been recognized that the spacing of the wheels of locomotives and cars influences the stresses developed in the rails, but there has been little information available as to the exact nature of this effect. A theoretical analysis of the stresses in the rail under a single wheel load made by the committee showed that a positive bending moment would be developed at the point directly under the wheels, while negative moments would occur a short distance on each side. To find the effect of a combination of wheel loads, the bending moment curves for each wheel were superimposed. In the reports the case of a typical Mikado locomotive was considered. The drivers were 66 in. apart, and each bore a

load of 27,500 lb. The leading wheel was 104 in. from the front driver and carried 12,500 lb. and the trailing wheel was 120 in. from the rear driver and its load was 20,000 lb. While the depression of the track is of course greatest under the center drivers, the maximum bending moment occurs under the end driving wheels. If the bending moment due to a single isolated load is taken as unity, the ratio of the combined bending moments to the bending moment of the single load is as follows:

Under the leading truck wheel.....	.74
Under the first driving wheel.....	.69
Under the second driving wheel.....	.55
Under the third driving wheel.....	.53
Under the fourth driving wheel.....	.71
Under the trailing truck wheel.....	.85

These deductions have been verified by experiments conducted on typical sections of track with the locomotive whose weights and dimensions are given above. In these tests strain gages and stremmatographs were used to determine the intensity of stresses at a point below the edge of the rail when under load. The stress under the inner two drivers was in most cases found to be less than under the outer drivers and that under the front driver was somewhat greater than that under the rear driver. One of the facts brought out that deserves special notice is that although the load on the trailer was only about three-fourths as much as on each driver, the stress under the trailer was nearly as great as under the outer drivers.

Moving load tests were also made with the locomotive running at several speeds in order to determine the effect of impact and the dynamic augment due to the counterbalance for the reciprocating parts. In these trials steam was shut off before the test section was reached and readings were taken with the locomotive drifting. The position of the drivers was such that the counterweight of the first driver was at its lowest point when the wheel passed over one of the recording instruments, but the other drivers had the counterweights in different positions. It might be expected that due to the dynamic augment the stresses under the drivers would increase as the square of the speed, however it was found that the increases in rail stresses under all wheels were directly proportional to the speed. The rate of increase ranged from 0.3 per cent to 1.2 per cent for each mile per hour increase in speed. The increase under the first driver was not greater than for the other wheels. The rate of increase of stresses under the tender truck wheels was higher than that under the drivers, which would seem to indicate that impact is of more importance than the dynamic augment due to the counterbalance. The stresses due to the weight of the trailer wheels were greater than those due to the driving wheel loads for all the weights of rail tested, which ranged from 85 lb. to 125 lb. per yard.

During one of the static tests the third driver of the locomotive, was temporarily blocked up as is sometimes done in service to prevent a bearing from heating. The stress under this wheel, which was ordinarily about 14,000 lb., decreased to 2,500 lb. Under the back driver the stresses increased from 15,000 lb. to 26,000 lb. and there were also considerable increases in the stresses under the second driver and smaller increases under the remaining wheels.

Tests with Atlantic and Pacific type locomotives gave results corresponding to those for the Mikado type noted above. Even for speeds up to 60 miles an hour the increase in the stresses was proportional to the speed. The stresses under the trailer wheels of these locomotives were not as high as with the Mikado type, since the trailer was spaced closer to the rear driver.

The most important point brought out by these tests is the high stresses due to the trailer wheel. Many have thought that very heavy loads could safely be placed on the trailer,

but this would seem to be a dangerous practice. The effect of wheel spacing on the stresses in track is a matter which should be given consideration in the design of locomotives and cars. It is to be hoped that the committee will secure additional information on this subject, as it is very much needed.

NEW BOOKS

Comparative Tests of Six Sizes of Illinois Coal on a Mikado Locomotive. By Edward C. Schmidt, et al. Bulletin No. 101, Engineering Experiment Station, University of Illinois, 100 pages, 6 in. by 9 in., bound in paper. Published by the University of Illinois, Urbana, Ill. Price 50 cents.

This bulletin contains a complete report of the tests which were run on the locomotive testing plant of the University of Illinois with a Baltimore & Ohio Mikado type locomotive, by the Committee on Fuel Tests of the International Railway Fuel Association, the Engineering Experiment Station of the University and the United States Bureau of Mines. An account of the same tests was presented by the Committee on Fuel Tests at the 1917 convention of the International Railway Fuel Association, an abstract of which report appeared on page 80 of the February, 1918, issue of the *Railway Mechanical Engineer*.

American Railway Tool Foremen's Association 1917 Year Book. Compiled by R. D. Fletcher, secretary and treasurer. 206 pages, 6 in. by 9 in., illustrated, bound in cloth. Published by the association.

On account of war conditions the 1917 convention was postponed so that the members of the association might not be called away from their work, but the annual year book was published as usual. In his letter of greeting, C. A. Shaffer, the president, expressed the hope that the preparation and publication of the year book would help maintain interest in the association so that its good work might be resumed when it is again possible to hold a convention. There are 18 papers in the book, prepared for the most part by members of the association and they are illustrated and well written. The subjects treated are divided into five classes: jigs and special devices, manufacture of small shop tools, special tools for boiler shops, heat treatment of tool steel, and the use of autogenous welding. A paper was written by E. Wanamaker, electrical engineer of the Rock Island lines, under the title of War and Welding, and it gives a valuable and somewhat exhaustive treatment of the subject.

Finding and Stopping Waste in Modern Boiler Rooms. Vol. II. By engineers of the Harrison Safety Boiler Works, Philadelphia, Pa. 274 pages, 4½ in. by 7 in., illustrated, cloth bound. Price \$1.

This book is designated as publication No. 821 and is a reference manual to aid the owners and operators of boiler rooms in securing and maintaining plant economy. The book is divided into five sections, the first of which, in a discussion of fuel, refers to the sizes of coal, coal sampling, analysis, heating value, purchase of coal under specifications, and storage and weathering problems. The second section on combustion takes up the chemistry of combustion and considers in detail the requirements for the efficient burning of coal. The third and fourth sections treat, respectively, of heat absorption and boiler efficiency, the latter section covering heat balance, heat absorbed by the boiler, heat losses due to moisture in the coal, hydrogen, chimney gases, CO, combustible in the ash, moisture in the air, and unaccounted for losses. The fifth section, on boiler plant proportioning and management, discusses various arrangements of auxiliaries with regard to their effect upon feedwater heating, and also describes the Polakov functional system of boiler room management. All statements, tables and charts have been selected with special reference to their reliability and this book will be found of material assistance to power house engineers.



RECLAMATION ON THE SOUTHERN PACIFIC

A Description of the Extensive Salvage Work Done
in the Largest Railroad Shop on the Pacific Coast

BY FRANK A. STANLEY

I

THE Sacramento, California, shops of the Southern Pacific constitute one of the most important railroad plants in America, holding first place in point of size among Pacific Coast shops, and, in fact, exceeding in extent the great majority of railway repair plants throughout the country as a whole. In variety of operations conducted within their numerous departments, they are excelled by few if any similar establishments anywhere. For, in addition to the usual sections constituting the average big rolling stock repair plant, this group of shops includes such important units as a large foundry for gray iron and chilled iron castings, a brass foundry for composition and brass castings, a wheel foundry for chilled-iron car and truck wheels and a rolling mill for producing merchant bar and a diversity of sections and shapes which are fabricated in the various shop departments. Then, too, the company operates here important car building shops; and in the machine shops, besides the regular work of overhauling and repairing rolling stock, a number of new locomotives are now turned out annually.

A further undertaking of interest in connection with repair operations, in that it is peculiar to this particular railroad plant, is the overhauling and upkeep of the mechanical equipment of numerous river steamers, ferry boats, dredging apparatus and other marine units operated by the company.

CONCENTRATION OF RECLAMATION WORK

As this is the biggest plant of the Southern Pacific, the most important of all the groups of shops located along its different lines, it is perhaps only logical that here should be centered one of the greatest of the system's industrial endeavors, the work of reclaiming old and discarded material from all of its divisions. And in this labor of reclamation, now an all powerful factor in every line of effort, lies one of the principle features of interest to the visitor at Sacramento.

Familiar as one may be in a general way with the handling of scrap material it is always interesting to learn what becomes of the enormous quantities of such material accumulated at different periods, and in what form it is destined to appear again in service. So far as concerns cast iron and brass scrap, there is, of course, small degree of complexity connected with its disposition. But wrought iron and steel parts that have found their way to the scrap heap form another problem altogether, and the disposal of such materials in extensive quantities is of particular interest.

In no line of activity is there greater accumulation of scrap of this character than in the operation of rolling stock. With, roughly, 70,000 locomotives and 2,500,000 cars in service over the 260,000 miles of track in our railway systems, there must necessarily develop a quantity of worn out and discarded material that constitutes in the aggregate, a vast volume of material when expressed in gross weight or in numbers of pieces.

The methods of the Southern Pacific at Sacramento hold much of value and interest to the student of reclamation work, not only because of the volume of business there daily transacted, but also on account of the diversified shop channels through which the scrap metal of the system is conducted in the various processes under which it is rehabilitated for service. With this fact in mind the following illustrations are here presented, along with certain data that may aid toward an understanding of some of the striking features of this important activity at the shops referred to.

A general view of the Sacramento scrap docks is reproduced at the head of this article. This photograph shows only a portion of the total area devoted to the dumping of the material switched in on the various spur tracks. While covering a fairly representative variety of scrap, the photo-

graph naturally falls short of conveying an adequate impression of the mass of material of all kinds that is constantly shipped in to this point, and which, as rapidly as it can be sorted, is hauled around to the rolling mill furnaces.



Fig. 1—Sorting Nuts for the Store House

the foundry, the forge shop, or to the special reclamation shops situated along the docks.

A closer view of one of the scrap piles is given in Fig. 2, showing the sorting of mixed scrap into big steel buckets, each of which is designated for a certain kind of part. These buckets when filled are picked up by the locomotive

In the sorting out of the scrap some 60 to 100 tons daily is prepared for the rolling mill furnaces, the capacity of the mill being easily the latter figure. The scrap for the mill is sorted into various classes, cut up into definite lengths, piled into units of 200 or 350 lb., placed on cradles on flat cars and thus transferred to the heating furnaces. In the mak-



Fig. 3—Old Air Brake Hose Storage

ing up of the piles at the dock sheds, plates, bars, levers, bolts, pins, etc., are cut by power shears and the oxy-acetylene torch. The plate sections are used for bottom and sides of a box like frame into which bolts, rod sections, and other pieces are piled and the whole pile then secured by flat iron straps clamped around it by an air operated press.

Details of the preparation of these piles and the methods



Fig. 2—Women Sorting Scrap at the Sacramento Shops of the Southern Pacific

crane and transferred to flat cars for hauling to some specified shop department. It will be noticed that the work of sorting and many of the reclamation operations in the scrap dock shops are performed very largely by women.

by which they are later passed through mill rolls, hammer, bulldozer, headers and other machinery in the manufacture of new parts will be taken up at another point in this article.

In the sorting of scrap, all parts that can be reclaimed in their original form without being worked into raw material for starting anew through the shop processes, are laid aside and classified for attention in the reclamation shops at the scrap docks. This means that great quantities of



Fig. 4—Painting Air Hose Couplings

track bolts, spikes, tie plates, car bolts, nuts, washers, pins, and a multitude of other materials are accumulated from the regular run of scrap and put into condition for further use by simple operations on the apparatus immediately to hand.

Bolts that are worn on the threads and bent out of shape

SOME SPECIFIC OPERATIONS

Two views in the scrap dock shops, Figs. 1 and 5, illustrate respectively, the sorting of nuts, and the re-tapping of nuts and the stripping of old air hose. In the case of square nuts alone, as many as 75,000 of various sizes are retapped in a single month at this point. Expressed in units of weight, this would amount to over 12,000 lb. or over six tons of nuts reclaimed in the period indicated. The multiple spindle tapping machine for nut operations

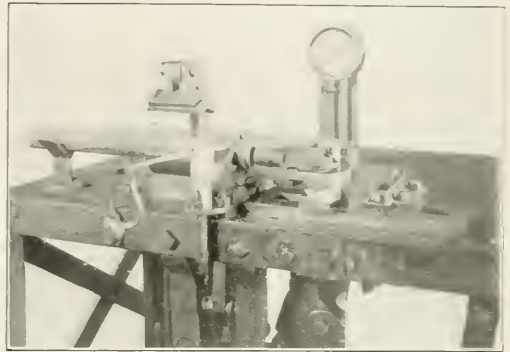

Fig. 6—Hose Coupler Mounting Machine

is seen at the left in Fig. 5, while to the right is the stripping bench for old air hose. Here the hose lengths are gripped in pneumatically operated jaws while the clamps and connections are rapidly removed.

The extent to which air hose is handled is indicated in Fig. 3, and a definite idea of the number of fittings reclaimed is found in the figures for a month's work, which show an average of 10,000 couplings and the same number of nipples for that period of time. An estimate on a con-



Fig. 5—Rethreading Nuts and Stripping Old Air Hose

are straightened, cut off and threaded; nuts are retapped; spikes straightened and sharpened; washers straightened and sorted for all sizes of bolts; hose couplings removed, painted and refitted to new hose lengths; and so on the parts are reclaimed and placed in proper bins in the general stores.

servative basis for a year's output in the reclamation of this material would run to at least 80,000 or possibly 100,000 air brake hose alone.

Fig. 4 shows something of the method followed in preparing the reclaimed hose couplings and nipples for remounting.

The process of painting here represented consists in dipping and brushing the fittings with a preparation which is composed of black varnish mixed with distillate in proportions of 1 to 2 to thin it to the desired consistency. After drying

placed on the slide at the right. The top jaw at the time the picture was taken was elevated as shown and the instant air pressure is admitted to the bottom operating cylinder, the jaw grips the hose fast while the air operated slide at the right is forced forward pressing the coupling into the hose. This movement takes place rapidly and is followed instantly by



Fig. 7—Reclaiming Track Bolts

they are remounted in new hose with the apparatus shown in Fig. 6. This is another pneumatic machine with air pistons



Fig. 9—Sorting Washers

the closing of the narrow jaws near the end of the hose upon the clamp, which is then tightened in place by applying the crank wrench at the front to the nut on the binder bolt. The wrench is carried in the right position by a swivel holder and



Fig. 8—A Corner of the Hose Testing Room

for controlling the action of the jaws and the movement of the carrier for the coupling.

The length of hose with the clamp on one end is slipped into the horizontal fixture on the bench and the coupling

accomplishes its work in a comparatively short time.

Another machine for applying clamps is seen to the left in Fig. 8, while to the right in the same view is the apparatus for testing the hose under pressure.

BOLTS, WASHERS AND OTHER PARTS

Fig. 7 shows the method of reclaiming of track bolts. Washers are sorted and grouped (Fig. 9), where different

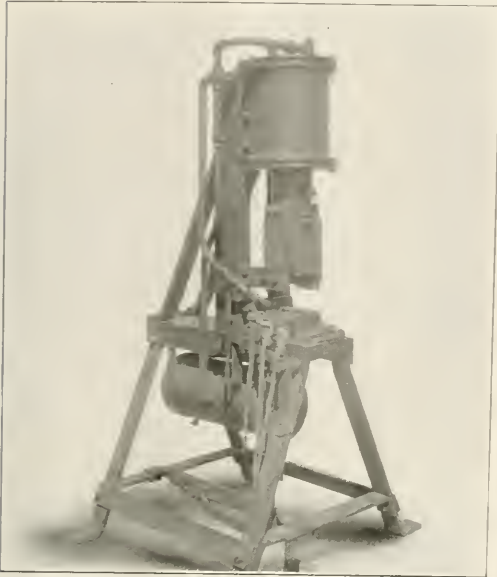

Fig. 10—Strengthening Hammer for Reclaiming Spikes

sizes are shown placed on individual pegs as fast as they are inspected, and are then transferred to the storage bins. Track spikes are reclaimed in great quantities, these being articles



Fig. 11—Sharpening Track Spikes

that once bent, seem never to appeal to the section hands until straightened and sharpened again. A special machine for the straightening operation is shown by Fig. 10. It is a

home made affair with air piston carrying a hammer die while the lower die is secured to the table of the machine. The apparatus is controlled by the foot lever at the front. As fast as they are straightened, the spikes are taken to the grinding machine shown in Fig. 11, where they are re-sharpened and are then ready to be shipped out on the road again for future work.

Among the odd items connected with important reclamation operations is the removing of zinc and brass from exhausted battery cells, a process illustrated in Fig. 12. Even this apparently small item results in the saving of a very considerable amount of valuable material in the course of a little time.

Another feature included in this view is a pile of locomotive shoes and wedges from which the brass liners have been melted, this practice resulting in the saving from such sources of about 250 lb. of metal daily, or nearly three tons of brass per month.

MISCELLANEOUS ITEMS

There are many things in process of reclamation at Sacramento that are practically impossible to illustrate, but which may be referred to as of importance in connection with the activities herein discussed. For example: One department handles the repairs to such tools as monkey wrenches, Stilson wrenches and other appliances, gate



Fig. 12—Reclaiming Metal from Old Batteries

valves, globe valves, pipe unions and fittings of all kinds, these miscellaneous items extending into an important total for the month's work.

In this period an average of 400 or 500 gate and globe valves are overhauled and put into shape by rescating and re-grinding operations carried out on special equipment, 100 or more wrenches of various types are repaired, and some 3,000 pipe unions of different sizes are reclaimed for service by tumbling in rattlers and dipping in wiping oil or distillate. Similarly in a small smith shop at the docks a blacksmith reclaims all sorts of bent and twisted material of fairly light weight.

Some indication of this is given in the statement for any average month's work which would include among other things the straightening and reforming of such items as: 1,000 coupling pins; 150 car carry irons; 54 air cylinder levers; 1,500 brake shoe keys; 70 coupling levers; 54 car angle irons; 125 steel bottom carry irons; 500 small corner irons; 260 large irons; 150 door hangers; 25 door fulcrums; 125 car levers; 2,000 oil box corners; 200 tie plates; 5,000 grab irons; and other miscellaneous small forgings of various kinds weighing 2,300 lb. Totalling up such items as the

above gives an aggregate weight of the reclaimed parts of over 70,000 lb., or some 35 tons, and this of course represents but a portion of the sum total of such material put into shape at the reclamation docks.

(To be concluded.)

DISTRIBUTION OF STANDARD LOCOMOTIVES TO THE RAILROADS

The United States Railroad Administration has placed orders for 390 locomotives in addition to the 1,025 ordered some time ago. The orders are divided about as follows: From the American Locomotive Company, 130 light Mikados, 100 6-wheel switching and 15 heavy Santa Fe. From the Baldwin Locomotive Works, 57 heavy Mikados, 13 light Pacific and 30 Consolidation for anthracite burning. From the Lima Locomotive Works, 45 light Mikados. This brings the total of orders placed with the three companies up to 800 to the American Locomotive Company, 570 to the Baldwin Locomotive Works, and 45 to the Lima Locomotive Corporation, a grand total of 1,415 locomotives. With the exception of the 30 Consolidation type locomotives for anthracite coal, the locomotives are all of the standard types.

An apportionment has been made of the locomotives and freight cars ordered by the Central Advisory Purchasing Committee, based on orders placed by the roads as revised by the regional directors and the administration at Washington. The cars and locomotives will not be treated as the property of the government or as a "circulating reserve," but become the property of the railroads in practically the same way as other equipment. The federal manager of each road has been notified of the number assigned to it and asked to submit a formal requisition to the Division of Capital Expenditures. The railroads will finance the equipment themselves wherever possible but if necessary they may apply to the government, through the Division of Finance and Purchases, for a loan from the revolving fund.

The assignment of the locomotives is as follows:

DISTRIBUTION OF STANDARD LOCOMOTIVES		
Railroads	Assignment	Total
LIGHT MIKADO		
Baltimore & Ohio.....	100	
Chicago & Alton.....	15	
Chicago & Eastern Illinois.....	15	
Chicago, Indianapolis & Louisville.....	5	
Chicago, Milwaukee & St. Paul.....	50	
Chicago, Rock Island & Pacific.....	20	
Grand Trunk, East.....	15	
Grand Trunk, West.....	25	
Lehigh & Hudson River.....	2	
Long Island.....	6	
Nashville, Chattanooga & St. Louis.....	10	
New York Central.....	95	
Big Four.....	25	
Lake Erie & Western.....	15	
Michigan Central.....	20	
Pittsburgh & Lake Erie.....	10	
Pittsburgh, McKeesport & Youngblood.....	10	
Rutland.....	6	
Toledo & Ohio Central.....	15	
Oregon Short Line.....	20	
Pittsburgh & West Virginia.....	3	
Seaboard Air Line.....	3	
Texas & Pacific.....	11	
Southern.....	25	
Union Pacific.....	30	
Wabash.....	20	
Western Pacific.....	5	575
LARGE MIKADO		
Central of New Jersey.....	25	
Chicago Great Western.....	10	
Elgin, Joliet & Eastern.....	2	
Erie.....	50	
El Paso & Southwestern.....	5	
Louisville & Nashville.....	20	
Missouri, Kansas & Texas.....	25	
Wheeling & Lake Erie.....	20	157
LIGHT MOUNTAIN		
New York, New Haven & Hartford.....	10	
Southern.....	25	35
LARGE MOUNTAIN		
Chesapeake & Ohio.....	5	5
LIGHT PACIFIC		
Atlantic Coast Line.....	20	
Baltimore & Ohio.....	20	
Kansas City Southern.....	3	43

HEAVY PACIFIC		
Erie.....	20	20
LIGHT SANTA FE		
Ash Grove.....	4	
Boston & Albany.....	10	
Baltimore & Ohio.....	26	
Chicago & Western Indiana.....	5	
Duluth, Missabe & Northern.....	10	
Pennsylvania Lines West.....	30	
Southern.....	10	
Seaboard Air Line.....	15	150
HEAVY SANTA FE		
Pennsylv. & Lake Erie.....	5	
Chicago & Eastern Illinois.....	5	
Erie.....	25	
Colorado & Southern.....	5	
Nashville, Chattanooga & St. Louis.....	10	50
6-WHEEL SWITCH		
Atlantic Coast Line.....	5	
Baltimore & Ohio.....	20	
Chicago Great Western.....	3	
Chicago Junction.....	14	
Chicago, Rock Island & Pacific.....	10	
Central Railroad of New Jersey.....	10	
Grand Trunk, Western.....	5	
Mobile & Ohio.....	10	
Oregon Short Line.....	5	
Pittsburgh & West Virginia.....	5	
Pennsylvania Lines West.....	20	
Seaboard Air Line.....	10	
Texas & Pacific.....	14	
Terminal St. Louis.....	10	
Union Pacific.....	10	150
8-WHEEL SWITCH		
Atlanta & West Point.....	2	
Erie.....	16	
Elgin, Joliet & Eastern.....	3	
Georgia.....	2	
Kansas City Terminal.....	5	
Long Island.....	4	
Missouri, Kansas & Texas.....	5	
New York Central.....	25	
Big Four.....	10	
Indiana Harbor Belt.....	20	
Kanawha & Michigan.....	3	
Lake Erie & Western.....	10	
Michigan Central.....	10	
Rutland.....	2	
Toledo & Ohio Central.....	5	
Southern.....	20	
Wheeling & Lake Erie.....	5	150
LIGHT MALLET		
Chesapeake & Ohio.....	20	
Chicago & Western Indiana.....	10	30
HEAVY MALLET		
Virginian.....	20	20
P. & R. STANDARD CONSOLIDATION		
Philadelphia & Reading.....	30	30
Total.....		1,415

The new locomotives will be required to work their way home, under steam and pulling a train of cars, according to a plan now under consideration by the Railroad Administration. The idea has been recommended by Frank McManamy, manager of the locomotive section of the Railroad Administration. It is estimated that this plan applied to 3,000 new locomotives a year would handle perhaps 500,000,000 ton-miles of freight a year, by enabling each engine to haul a train, instead of itself occupying tonnage in a train equal to about three cars. The idea is to have the engines accompanied by a messenger from the locomotive plant, according to the usual practice, to look after the bearings, etc., during the trip, and to have them handled by regular crews of the roads over which they pass. It is believed that they will be delivered in better condition if used at the front of a train and given a thorough inspection at terminals than if handled in the usual way and that they may be "broken in" just as satisfactorily in this way as if the process were postponed until their arrival at the home road.

W. S. S. NURSERY RHYME

"Gin a lassie meet a laddie, going to the Kaine,
Here's a lass would help ye, laddie, Savings Stamps I'm buyin'.
Every lassie has a laddie! And I think of mine,
But all the lads they smile at me when Savings Stamps I'm a buyin'!"
—*Prover Bulletin.*

DRAFTING MODERN LOCOMOTIVES

A Study of the Steps Taken in Developing Maximum Draft Efficiency on N. & W. 4-8-2 Type Locomotive

BY H. W. CODDINGTON
 Engineer of Tests, Norfolk & Western, Roanoke, Va.

II

IN compiling the data obtained from the Norfolk & Western 4-8-2 type drafting tests, they have been arranged to show a ready comparison of the standard nozzles with and without bridges, the influence of the length of the inside extension of the stack, the sizes of nozzles, both standard and annular, as well as the diameters of the stacks. The results as shown in the tables are the averages of one

were more uniform and consistent than the least back pressure results as taken from the indicator cards. The exhaust pressure was indicated directly while least back pressure results could be affected by slight lost motion in indicator parts, the tracing of the diagrams, and possible error in scaling the least back pressure with a 120-lb.-per-sq.-in. scale.

COMPARISON OF STANDARD NOZZLE WITH AND WITHOUT BRIDGE

In Table I, group A, attention is directed to the performance of the locomotive while equipped with a 7-in. diameter standard nozzle operating with and without a bridge. The design of this standard nozzle is shown in Fig. 4. The 7-in. standard nozzle was tried in connection with an 18-in. diameter stack provided with 26½-in., 14¼-in. and 9-in. inside extensions. The results from run No. 17 are representative of the locomotive's performance with the standard front end arrangement; the larger exhaust stand used was the only deviation from the standard arrangement. In run No. 18 the same arrangement of front end was used except that the ¾-in. bridge was removed from the standard nozzle. The removal of the bridge naturally increased the area of the nozzle, which had its effect both upon the reduction of exhaust pressure and reduction of the draft. Column No. 13, "Draft efficiency," has been recognized as a convenient means of comparing draft performances of locomotives, as in it are involved both the exhaust pressure and draft results. This item is obtained by dividing the draft, expressed in pounds per square inch, by the exhaust pressure.

With the 26½-in. inside extension of the stack, the draft

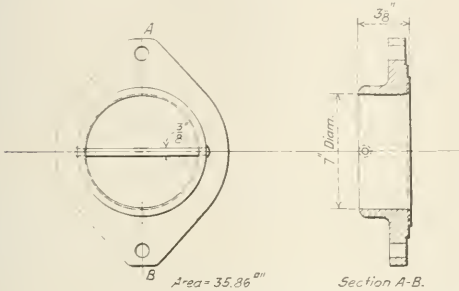

Fig. 4—The Seven-Inch Nozzle with a Bridge Originally Used on N. & W. Mountain Type Locomotives

or more runs, as indicated by the run numbers in column No. 1.

In referring to the results of these tests, as presented in the tables, the items "Exhaust pressure," "Draft, front end" and "Draft efficiency" will receive the most consideration.

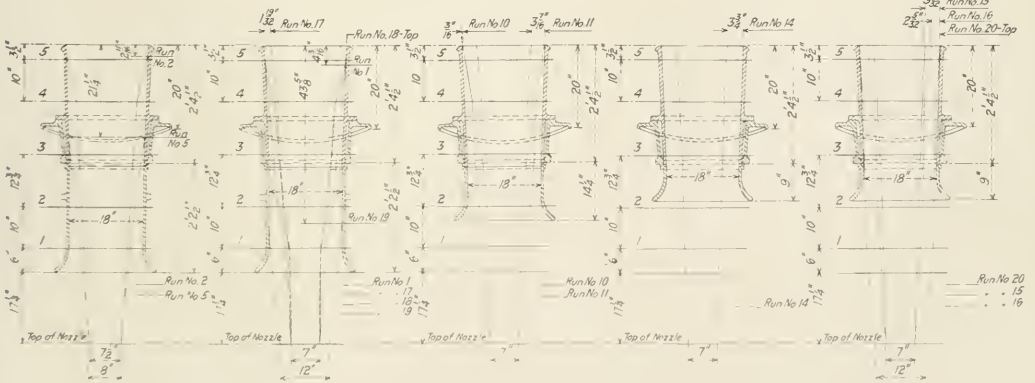

Fig. 5—Exhaust Stack Diagrams for Runs 1, 2, 5, 10, 11, 14, 15, 16, 17, 18, 19 and 20

Exhaust pressure as obtained from steam gage indication has been used in preference to least back pressure obtained from the indicator diagrams, as the exhaust pressure readings

efficiency is 3.6 per cent higher when the bridge is used with a standard nozzle. In the 14¼-in. inside extension, the draft efficiency is 6.7 per cent higher with the use of a bridge, while with the 9-in. inside extension it is observed that the draft efficiency is 10 per cent better with the bridge removed.

* For first article see *Railway Mechanical Engineer* for June, 1918, page 331.

The fact that the exhaust did not fill the stack, either with or without the bridge with the 9-in. inside stack extension, is the possible reason why the removal of the bridge had an influence on the draft efficiency the reverse of what had already been observed.

In Fig. 5 the position of the exhaust columns with relation to the inside walls of the stack is shown for the tests included in group A. It has been observed in connection with these tests that shortening the inside extension had the same influence upon the relationship existing between the position of the exhaust column and the walls of the stack as did increasing the diameter of the stack. It is noticed in run No. 16, where no bridge was used, that the exhaust

Table II gives further information in connection with the operating conditions of the test and some of the results obtained. Still directing attention to the results in group A, it is observed that the operating conditions were very uniform, as far as the number of cars and tonnage in the train were concerned. Under item No. 24 the amount of water used for

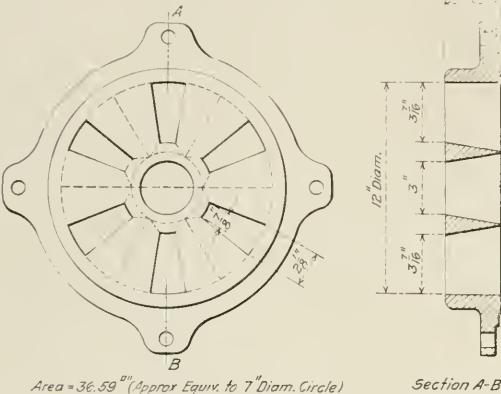

Fig. 6—Plain Annular Nozzle A-1

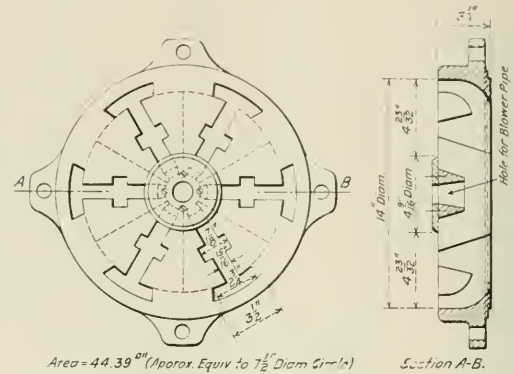

Fig. 8—Waffle Iron Nozzle A-2

column more nearly filled the stack than in runs No. 14-15 where the bridge was employed. This feature of the exhaust in run No. 16 is no doubt responsible for the slightly increased draft efficiency which has been recognized, as it has been observed throughout this series of tests that the draft conditions are improved when the relation of the exhaust

each run is shown. This represents the steam consumed by the locomotive and accessories, such as air pumps and stoker engine. Special care was taken to see that no waste of steam occurred through the safety valves during the test. By observing the intensity of the draft in the locomotive front end between the baffle plate and the front tube sheet, and in the fire box, it was possible to determine the draft effort expended in drawing combustion gases and air through the different sections of the boiler. It will be observed that from 16.3 to 19.5 per cent of the draft effort was required to draw the gases under the diaphragm; from 61.5 to 66.6 per cent of the draft was expended in drawing the gases through the tubes, and from 14.8 to 20.5 per cent of the draft effort was required to draw the air through the fire bed.

The fuel used in these tests was fairly uniform in quality,

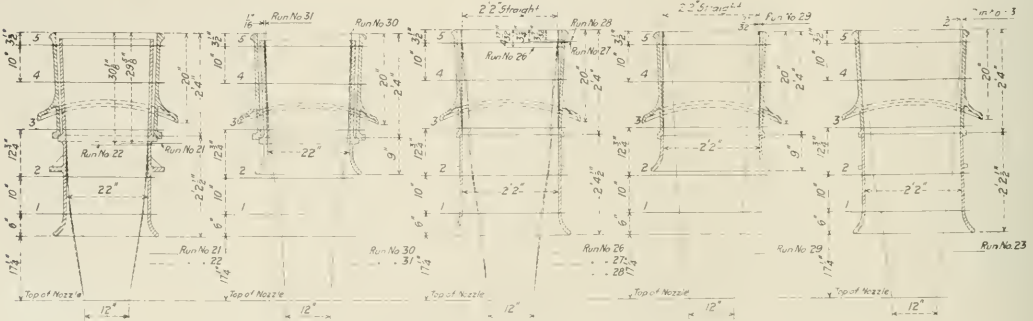

Fig. 7—Exhaust Stack Diagrams for Runs 21, 22, 23, 26, 27, 28, 29, 30 and 31

column and stack are such that the exhaust completely fills the stack before being discharged. The increase in draft efficiency secured with the 7-in. standard nozzle without the bridge, using a 9-in. inside stack extension, was obtained at the expense of a decided decrease in draft, which was counter to the object of the test, as the primary purpose was to improve the draft without creating an objectionably high exhaust pressure.

ranging from 13,000 B.t.u. to 14,000 B.t.u. The analyses of the smoke box gases indicated that very good combustion results were being obtained. The values for CO₂ with but few exceptions, ranged from 10.2 per cent to 12.4 per cent.

COMPARISON OF LONG AND SHORT INSIDE STACK EXTENSIONS

In Tables I and II, group B has been arranged particularly for a study of the influence of the length of the inside

stack extension. Included in this group of data are the results obtained from a special annular nozzle, style A-1, as illustrated in Fig. 6. This nozzle has six equally spaced annular ports of equal area and one center circular port. The combined areas of the ports were made to correspond to the areas of 7-in. and 7½-in. diameter circles.

The first comparison in group B, Table I, is that of the 7-in. diameter nozzle with a ⅜-in. bridge, used with an 18-in. diameter stack with 26½-in. and 9-in. inside extensions. The higher draft as well as the slightly higher draft efficiency was obtained with the 26½-in. inside extension. Under neither of these conditions was the exhaust filling the stack, but with the longer extension (run No. 17) it was more

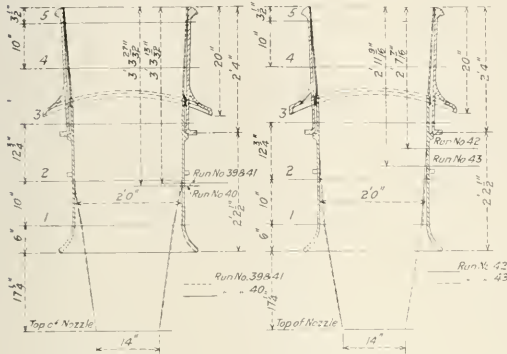

Fig. 9—Exhaust Stack Diagrams for Runs 39-41, 40, 42 and 43

closely approaching the walls of the stack than in runs No. 14-15 with the short extension, as indicated by the exhaust diagrams shown in Fig. 5. Runs No. 19 and 20 provide a comparison of nozzle style A-1 used with an 18-in. diameter stack with 26½-in. and 9-in. inside extensions. The better draft condition is again observed with the 26½-in. inside extension; the draft efficiency in this combination was 0.031 as against 0.028 with the 9-in. extension. The exhaust column and stack diagrams for runs No. 19 and 20 are also shown in Fig. 5. It will be noticed with the 26½-in. inside extension that the exhaust is striking near the bottom of the inside extension, or 435⁄8 in. from the top, but with the 9-in. inside extension the exhaust, while almost in contact with the stack in its passage, does not absolutely strike until it reaches the top.

Attention should be directed to the marked contrast in the draft obtained from run No. 17 as compared with run No. 19, where the only difference in the front end arrangement was the different type of nozzle used, the former run representing the performance of the standard 7-in. diameter nozzle with ⅜-in. bridge where a draft of only 8.91 in. of water was registered, while the latter shows nozzle style A-1 with area equivalent to a 7-in. diameter circle, where a draft of 10.1 in. of water was registered. The draft efficiency was also increased from 0.029 in the former instance to 0.031 in the latter.

Runs No. 21-22 and 30-31 show the results obtained from nozzle style A-1 enlarged to correspond to the area of a 7½-in. diameter circle, operated in connection with a 22-in. diameter stack with 26½-in. and 9-in. inside extensions. In this comparison, the higher draft was obtained with the 26½-in. inside extension. It will further be noticed that the draft efficiency was 0.046 with the 26½-in. inside extension as compared with 0.040 with the 9-in. inside extension. The exhaust column stack diagrams for these runs are shown as Fig. 7. It will be observed that, with the 26½-in. inside extension, the exhaust was striking the stack 29⁷⁄8 in. from

the top, while with the short inside extension the exhaust was missing the stack by ¼ in. at the location of the top Pitot tube, although, as indicated by the diagram, the exhaust was very closely paralleling the walls of the stack after 12 in. entry into the lower section.

The records from runs No. 26-27-28 contrasted with run No. 29, give the results obtained from using nozzle style A-1 with area equivalent to a 7½-in. circle, operated in conjunction with a 26-in. diameter straight stack with 26½-in. and 9-in. inside extensions. In this, as in former comparisons of the same nature, the better draft performance was obtained with the 26½-in. inside extension, where a draft efficiency of 0.048 was secured, as compared with 0.040 with the 9-in. inside extension. The exhaust stack diagrams are shown in Fig. 7, where it is observed that the exhaust column was clear of the stack until it closely approached the top. In runs No. 26-27-28 with the 26½-in. inside extension, the exhaust column encountered the walls of the stack 35⁄8 in. from the top while in run No. 29 with the 9-in. inside extension, the exhaust missed the stack by ¼ in. at the top.

In Table II, group B, is given further information as to the operating conditions, together with some of the results obtained, particularly with reference to running time, as shown in column No. 15. The draft effort absorption required to draw the combustion gases and air through the different sections of the boiler, as shown in columns No. 18, 19 and 20, are values of peculiar interest.

Attention should be directed to the increase in the tonnage of the train after the first test was made with nozzle style A-1 with area equivalent to a 7½-in. diameter circle. With the same train tonnage as formerly used, it was necessary frequently to apply the brakes to restrict the speed. In succeeding runs with this same size nozzle, the tonnage was increased until, for runs No. 26 to 29, inclusive, the tonnage was 639.5 and 640.1, whereas the tonnage had been averaging slightly above 600 tons.

From a review of the data relating to the length of the

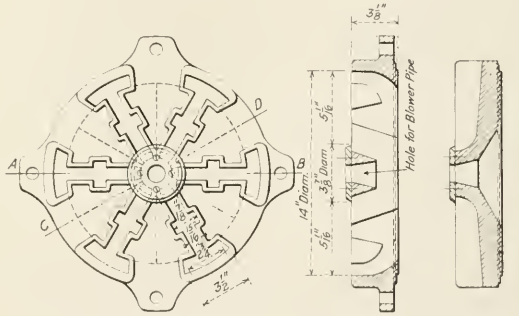

Area = 44.32 sq. in. (Approx. Equiv. to 7½ Diam. Circle) Section A-B. Section C-D.

Fig. 10—Waffle Iron Nozzle A-3

inside extension, the conclusion is reached that the best results are obtained from the 26½-in. inside extension. It was also observed that the best draft conditions cannot be obtained unless the exhaust strikes the stack, and that the draft conditions are improved as the point of contact with the stack occurs about 38 in. from the top, which is equal to approximately 70 per cent of the length of the stack.

The introduction of the annular nozzle, style A-1, gave considerably better performance than the former standard nozzle, as it was found possible to operate this nozzle with an area equivalent to a 7½-in. diameter circle, and when used in conjunction with a 22-in. diameter stack and a 26½-in. inside extension, a draft of 10.39 in. of water was obtained, with a draft efficiency of 0.046, as compared with

TABLE I

Run No.	Stack diam. in.	Length inside exten- sion, in.	Act'or equiv. diam. in.	Style and diam. of bridge	Area	Speed, M. P. H.	Pressure, lb. per sq. in.			Draft, in. water			† Draft efficiency	‡ Exhaust jet striking, in. from top of stik.	
							Boiler	Exhaust	Front end	Front end	Back of baffle	Firebox			
GROUP A—COMPARISON OF BRIDGE AND NO. BRIDGE IN STD. NOZZLES (EXHAUST STAND 12 IN. IN DIAM.)															
17	18	26½	7	S ¾	35.86	33.0	192.5	10.94	8.91	7.3	1.5	.029	—	1 ½	
18	18	14½	7	S none	38.48	30.2	187.4	8.13	6.34	5.10	1.12	.028	—	Top	
11	18	14½	7	S ¾	35.86	37.8	194.4	7.83	7.00	5.86	1.40	.032	—	3 7/16	
10	18	14½	7	S none	38.48	29.4	192.8	7.68	6.51	5.34	1.34	.030	—	4 1/16	
14-15	18	9	7	S ¾	35.86	31.3	194.4	9.81	7.60	6.28	1.28	.028	—	3 11/16	
16	18	9	7	S none	38.48	30.5	193.6	7.63	6.58	5.40	1.10	.031	—	2 ½	
GROUP B—COMPARISON OF LENGTH OF INSIDE STACK EXTENSIONS (EXHAUST STAND 12 IN. IN DIAM.)															
17	18	26½	7	S ¾	35.86	33.0	192.5	10.94	8.91	7.25	1.32	.029	—	1 ½	
14-15	18	9	7	S ¾	35.86	31.3	194.4	9.81	7.60	6.28	1.28	.028	—	3 11 16	
19	18	26½	7	A-1	36.59	33.5	195.1	11.82	10.10	8.15	1.40	.031	—	4 3/16	
20	18	9	7	A-1	36.59	33.3	194.7	10.25	8.04	6.44	1.23	.028	—	Top	
21-22	22	26½	7½	A-1	44.38	33.5	193.8	8.13	10.39	8.63	1.68	.046	—	29 ½	
30-31	22	9	7½	A-1	44.38	32.7	191.9	8.81	9.82	8.03	1.25	.040	—	¼	
26-27-28	26 Strt.	26½	7½	A-1	44.38	31.0	194.6	6.00	7.95	6.49	1.25	.048	—	3 ¾	
29	26 Strt.	7½	7½	A-1	44.38	32.0	194.5	6.32	7.01	5.81	1.05	.040	—	¼	
GROUP C—COMPARISON OF SIZES OF STANDARD NOZZLES															
17	18	26½	7	S ¾	35.86	33.0	192.5	10.94	8.91	7.25	1.32	.029	—	1 ½	
5	18	26½	7½	S none	44.18	25.7	170.0	6.50	6.10	4.97	1.34	.034	—	2 1/16	
2	18	26½	8	S ¾	47.6	29.0	185.9	6.44	7.36	5.98	1.58	.041	—	2 11/16	

* Standard nozzles designated by the letter "S"; Annular nozzles by the letter "A" followed by a number identifying the particular type of nozzle employed.
 † Draft efficiency equals draft in pounds divided by exhaust pressure.
 ‡ Exhaust missing the top of the stack is indicated by negative values.

TABLE II

Run No.	Running time, hrs.	Train			Per cent total draft required				Water			Equiv. evap. per sq. ft. h. s. per hr.	
		No. cars	Tons		Under diaphragm	Through tubes	Through fire	Pounds	Temp., deg. F.				
GROUP A—COMPARISON OF BRIDGE AND NO. BRIDGE IN STD. NOZZLES (EXHAUST STAND 12 IN. IN DIAM.)													
17	.40	9	600.5	18.6	66.6	14.8	21,925	57.0	13.69				
18	.43	9	600.5	17.4	65.6	17.7	22,700	56.0	13.78				
19	.50	9	602.9	16.3	63.7	20.0	23,775	56.0	11.93				
10	.45	9	602.9	18.0	61.5	20.5	22,950	53.0	12.78				
14-15	.43	9	602.9	17.4	65.6	17.0	24,887	56.0	14.32				
16	.45	9	602.9	17.9	65.3	16.8	23,223	56.0	12.73				
GROUP B—COMPARISON OF LENGTH OF INSIDE STACK EXTENSIONS (EXHAUST STAND 12 IN. IN DIAM.)													
17	.40	9	600.5	18.6	66.6	14.8	21,925	57.0	13.69				
14-15	.43	9	602.9	17.4	65.6	17.0	24,887	56.0	14.32				
19	.43	9	600.5	19.3	66.8	13.9	22,700	55.0	13.21				
20	.40	10	605.1	19.9	64.8	15.3	21,750	54.0	13.61				
21-22	.39	10	605.1	16.9	66.8	16.3	22,950	52.0	14.52				
30-31	.41	12	618.1	18.3	68.9	12.8	24,775	54.0	14.06				
26-27-28	.42	12	640.1	18.3	65.8	15.9	21,958	60.7	12.92				
29	.42	12	639.5	17.1	67.9	15.0	22,100	60.0	13.10				
GROUP C—COMPARISON OF SIZES OF STANDARD NOZZLES													
17	.40	9	600.5	18.6	66.6	14.8	21,925	57.0	13.69				
5	.57	16	618.2	18.5	59.5	22.0				
2	.47	16	618.2	18.7	59.8	21.5				

TABLE III—COMPARISON OF NOZZLE STYLES AND SIZES OF STACKS

Run No.	Stack diam. in.	Length inside exten- sion, in.	Act'or equiv. diam. in.	Style and diam. of bridge	Area	Speed, M. P. H.	Nozzle Pressure, lb. per sq. in.			Draft, in. water			† Draft efficiency	‡ Exhaust jet striking, in. from top of stik.
							Boiler	Exhaust	Front end	Front end	Back of baffle	Firebox		
5	18	26½	7½	S none	44.18	25.7	170.0	6.50	6.10	4.97	1.34	.034	2 1/16	
21-22	22	26½	7½	A-1	44.38	33.5	193.8	8.13	10.39	8.63	1.68	.046	29 ½	
23	26	26½	7½	A-1	44.38	30.0	191.0	6.17	8.31	7.04	1.25	.048	3 ½	
26-27-28	26 Strt.	26½	7½	A-1	44.38	31.0	194.6	5.00	7.95	6.49	1.25	.048	3 1/16	
39-40*	24	26½	7½	A-2	44.39	32.1	197.4	6.97	10.15	8.56	1.59	.052	39 ¾	
41-42*	24	26½	7½	A-3	44.32	32.1	192.1	7.57	11.52	9.51	1.57	.055	35 7/16	
68-69	24	26½	7½	A-3	44.32	31.8	199.5	8.12	11.94	9.77	1.58	.053	39 ¾	
43*	24	26½	7½	A-4	44.22	32.1	200.0	9.29	11.70	9.64	2.11	.045	35 9/16	
72-73*	24	26½	7½	A-4a	44.23	32.0	200.1	9.00	12.79	10.50	2.04	.051	35 ¾	
64-65	20	26½	7½	A-5	44.26	31.9	195.7	7.90	9.77	7.39	1.51	.040	42 ¾	
54-55	22	26½	7½	A-5	44.26	31.9	195.3	8.77	9.74	8.24	1.74	.040	3 1/16	
47-49	26	26½	7½	A-5	44.26	29.9	194.2	7.01	8.79	7.36	1.70	.045	—	
66	20	26½	7½	A-6	44.32	31.6	196.1	9.07	9.91	8.37	1.54	.039	3 1/16	
52-53	22	26½	7½	A-6	44.32	32.0	196.8	8.79	10.20	8.50	1.69	.042	2 1/16	
50-51	26	26½	7½	A-6	44.32	31.2	195.8	7.72	9.29	7.85	1.74	.043	—	
56-57	26	26½	7½	A-8	44.12	31.3	197.0	8.38	10.75	8.96	1.70	.046	41 5/16	
58-59-60	26	26½	7½	A-9	47.35	30.4	195.0	6.16	7.37	6.72	1.45	.046	—	
61-62	26	26½	7½	A-10	47.12	30.2	195.8	5.36	7.65	6.58	1.47	.051	1 ½	

* Flare of stack increased on these runs.
 † Draft efficiency equals draft in pounds divided by exhaust pressure.
 ‡ Exhaust missing the top of the stack is indicated by negative values.

TABLE IV—COMPARISON OF NOZZLE STYLES AND SIZES OF STACKS

Run No.	Running time, hrs.	Train			Per cent total draft required				Vacuum between nozzle ports, in. water (see Fig. 18)			Water		Equiv. evap. per sq. ft. h. s. per hr.
		No. cars	Tons		Under diaphragm	Through tubes	Through fire	A	B	C	Pounds	Temp., deg. F.		
1	15	16	17	18	19	20	21	22	23	24	25	26		
5	.57	16	618.2	18.5	59.5	22.0	22,950	52.0	14.59	
21-22	.39	10	605.1	16.9	66.8	16.3	23,125	52.0	13.32	
23	.45	11	637.4	15.3	69.7	15.0	23,925	52.5	13.92	
26-27-28	.42	12	640.1	18.3	65.8	15.9	21,958	60.7	12.92	
39-40	.42	15	628.2	15.7	68.7	15.6	22.41	24.83	19.21	22,975	64.0	13.41		
41-42	.42	14	629.7	17.4	69.0	13.6	18.71	18.33	15.04	23,125	64.0	13.50		
68-69	.40	14	635.2	18.2	68.6	13.2	17.36	19.59	20.47	23,025	69.0	14.25		
43	.42	14	653.1	17.6	64.4	18.0	22.89	31.62	24.44	22,650	63.0	13.40		
72-73	.40	14	635.2	17.8	66.2	16.0	20.08	20.76	19.69	20,963	69.3	12.96		
54-55	.40	14	624.1	15.6	67.1	11.3	11.15	15.04	13.59	22,425	69.5	13.54		
50-51	.42	14	628.0	15.5	65.7	18.8	9.35	10.67	9.35	21,788	70.0	12.83		
56-57	.41	14	634.8	16.6	67.6	15.8	12.12	14.55	13.29	23,200	68.0	13.84		
58-59-60	.47	15 and 14	632.7	14.6	66.9	18.5	7.76	9.83	8.99	21,360	66.8	12.45		
61-62	.42	14	611.5	13.9	66.9	19.2	7.66	10.77	9.80	21,300	66.3	12.43		

a draft of 8.91 in. of water and a draft efficiency of 0.029, the best results secured from a 7-in. diameter standard nozzle with a 3/8-in. bridge. This initial favorable showing of the annular type nozzle led to further developments of the design, which will be introduced later.

COMPARISON OF STANDARD NOZZLES OF DIFFERENT SIZES

Group C in Table I shows a comparison of the results of different sizes of standard nozzles, which, while not of particular interest in connection with improvement in the performance of the locomotive, suggests the limitations that would have been encountered had development been restricted to the standard type of nozzle. The highest draft efficiency obtained from the standard nozzles was with the 8-in. diameter nozzle with a 3/8-in. bridge, where a draft efficiency of 0.041 was secured, but it is observed in securing this draft efficiency that the draft itself was too low (7.36 in. of water) for the successful performance of the locomotive.

The results of run No. 5 give the performance of the 7 1/2-in. standard nozzle without a bridge, used in connection with an 18-in. stack and 26 1/2-in. inside extension, from which a draft of 6.10 in. of water and a draft efficiency of 0.034 were obtained. From these results, when contrasted with the results obtained from nozzle style A-1 with area equivalent to a 7 1/2-in. diameter circle (group B, runs No. 21-22), where a draft of 10.39 in. of water and a draft efficiency of 0.046 were secured, the value of the annular type nozzle becomes apparent. The exhaust stack diagrams for these runs are shown in Figs. 5 and 7. In Fig. 5 it will be noticed that, for run No. 5 with the standard 7 1/2-in. nozzle, the exhaust column was striking 21 1/4 in. from the top of the stack. In Fig. 7 for runs No. 21-22, the exhaust column was striking 29 7/8 in. from the top of the stack, which shows there was a similar relationship between the exhaust column and the stack, and further leads

diameter circle were used, and where in each instance 26 1/2-in. inside stack extensions were employed. The results from run No. 5, in which the locomotive was equipped with an 18-in. diameter stack and a 7 1/2-in. standard nozzle without a bridge, are shown in the first line of the table for comparison with the other combinations of annular nozzles and stacks. The results of runs No. 21-22 are again shown to afford further comparisons. During run No. 23, a 26-in. diameter stack was used with the same inside extension and size of nozzle as used in runs No. 26-27-28, where a 26-in. diameter straight stack was employed. With the standard taper stack the draft obtained was slightly improved, while

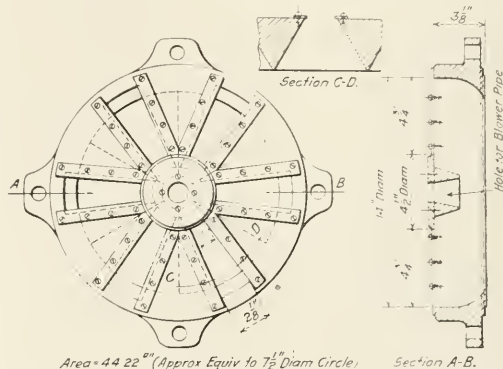

Fig. 12—Annular Nozzle A-4

the draft efficiency under each condition was identical, which leads to the conclusion that no advantage was gained by using the straight stack. The exhaust stack diagrams for these two sets of runs is shown in Fig. 7.

The satisfactory results from nozzle style A-1 encouraged further investigation along this line, and nozzle style A-2 was developed. This is illustrated in Fig. 8. It should be noted that the center opening shown in this drawing is provided to accommodate a central blower pipe and is not a nozzle port.

The theory followed in designing these nozzles on a larger external circle with the exhaust opening divided into annular ports, was to afford greater opportunity for the entrainment of the combustion gases by increasing the external surface of the exhaust column which is exposed for contact with the gases. Hence, in the design of nozzle style A-2 it was constructed on a 14-in. external circle, which is two inches larger than that of nozzle style A-1. Furthermore, the annular ports, instead of conforming in shape to a vertical section through a frustum of a cone, have been provided with side or wing extensions. The shape of the ports in this nozzle suggested the name "waffle iron" nozzle, by which it is now generally known. The 14-in. diameter nozzle was constructed so it could be applied to the 12-in. diameter exhaust stand installed before run No. 12 was made.

Waffle iron nozzle style A-2 was used with a 24-in. diameter stack on runs No. 39-40. Very satisfactory results were obtained from this combination; the draft in the front end averaged 10.15 in. of water and the draft efficiency was 0.052. The exhaust stack diagrams for these runs are shown in Fig. 9. In both of these runs the exhaust was striking well down in the stack, averaging 39 5/8 in. from the top.

A further development of the annular nozzle is waffle iron nozzle style A-3, shown in Fig. 10. This nozzle is identical with style A-2 in every respect except that the

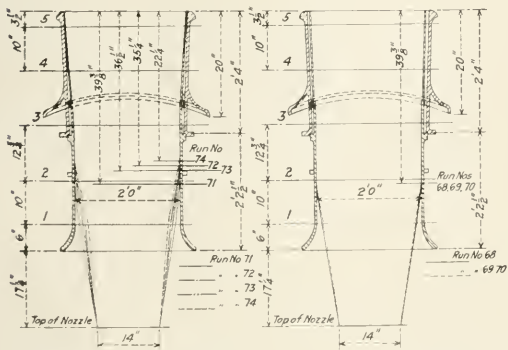

Fig. 11—Exhaust Stack Diagrams for Runs 68, 69-70, 71, 72, 73 and 74

to the conclusion that the marked difference in draft results was due directly to the special type of annular nozzle used.

COMPARISON OF STYLES OF NOZZLES AND SIZES OF STACKS

In consideration of data already presented the conclusion was reached that the standard nozzle gives the best results when used with a 3/8-in. bridge, and further that the best draft conditions were obtained when a 26 1/2-in. inside extension was used. An effort will now be made to further consider how draft conditions are affected by the diameter of the stack and the particular type or style of nozzle used. For this purpose, Table III has been prepared in which, with but two exceptions, only nozzles equivalent to a 7 1/2-in.

outside top surface of the nozzle is cored out between the annular ports. This was done for the purpose of providing additional opportunity for entraining the smoke box gases between the exhaust ports. That there was an entraining action at the top surface of the nozzle was demonstrated by the abrasive action of the cinders upon the surface of the nozzle between the ports. The intensity of the vacuum between the exhaust ports is shown in Table IV, columns No. 21, 22 and 23.

The results obtained from the use of nozzle style A-3, in combination with a 24-in. diameter stack and a 26½-in. inside extension, are shown as the average of runs No. 41-42 and as an average of runs No. 68-69. In the results from runs No. 41-42, attention should be directed to the relation between exhaust pressure and draft; the former is 7.57 lb. per sq. in. and the latter 11.52 in. of water, producing a draft efficiency of 0.055. These results might be compared with those obtained from the locomotive, while equipped with the standard front end arrangement, where the exhaust pressure for run No. 17. Table I was 10.94 lb. per sq. in. while the draft was 8.91 in. of water and the draft efficiency only 0.029. The results from runs No. 68-69, which, except for a difference in the stack flare, had the same front end equipment as used in runs No. 41-42, varied slightly from the results of runs No. 41-42; the draft and exhaust pressure are both slightly higher and the draft efficiency slightly lower. The exhaust stack diagrams for runs No. 41-42 are shown in Fig. 9, and for runs No. 68-69 in Fig. 11. In both instances, the exhaust was striking well down in the stack, a distance of 35 7/16 in. from the top for runs No. 41-42, and 39 3/8 in. for runs No. 68-69.

The successful results obtained from nozzle style A-3

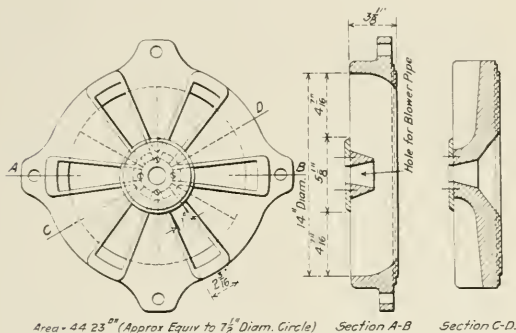

Fig. 13—Plain Annular Nozzle A-4a

raised the question as to whether the same satisfactory results might not be obtained from the same type of nozzle with plain annular ports, and nozzle style A-4 was improvised for this comparison. This nozzle, which is illustrated in Fig. 12, was cast off of the same pattern as nozzle style A-3 and the ports straightened by machining off excess metal entering within the bounds of the shape of the opening desired. Plates were then applied to bring the openings to the size desired. This nozzle was used in run No. 45 with the same stack combination as used in connection with waffle iron nozzle style A-3. While as satisfactory draft conditions were obtained, the average exhaust pressure was increased, resulting in a reduction in draft efficiency as compared with that obtained from nozzle style A-3. As both nozzles had the same free opening, there appeared no reason for increased exhaust pressure, unless the inwardly projecting edges of the plates used to restrict the ports to the dimensions required offered an increase in

resistance to the passage of the exhaust, a condition which may be considered quite probable. It will be observed in Fig. 9 that the exhaust jet delivered by nozzle style A-4 was striking the stack at approximately the same position as in run No. 42, which run produced some of the best results obtained.

In a further effort to demonstrate the results that might be obtained from a plain annular exhaust port opening, nozzle style A-4a was cast with plain annular ports, as shown in Fig. 13. This nozzle featured in runs No. 72-73 and gave excellent results with respect to draft, but the high draft was accompanied by a high exhaust pressure, which resulted in a lower draft efficiency than was obtained from waffle iron nozzle style A-3. The exhaust stack diagram is shown in Fig. 11, where it is observed that the exhaust is striking the stack an average distance of 35 7/8 in. from the top, a location for striking from which the best draft conditions have been obtained. It is difficult to reconcile the difference in exhaust pressure experienced with the plain annular nozzle as compared with the waffle iron nozzle, style A-3, since the latter is more irregular in contour and it seems would naturally offer more surface resistance to the passing of the exhaust.

(To be Concluded.)

THE MEANING OF W. S. S.

By JACK CUTLER

W.—Means We will win this war.

A.—America we are fighting for.

R.—Is for Right for which we stand.

S.—Is for Safety on sea or land.

A.—For our Army which never failed.

V.—For Victory which soon will be hailed.

I.—For Independence, America's aim.

N.—For our Navy of very great fame.

G.—Is for Glory which heroes attain.

S.—Is for Ships which are sailing around.

T.—Is for Tears in many homes found.

A.—For our Allies who will help win this war.

M.—For the Mothers who will grieve no more.

P.—Means Peace for one and all.

S.—Is for a Sound of the liberty call.

—Pioneer Bulletin.

MECHANICAL LABOR-SAVERS ON FRENCH RAILWAY.—Le Genie Civil says that the Orleans Railway, feeling the shortage of labor, has successfully adopted mechanical cleaning devices both for railway cars and hired cabs, in addition to vacuum cleaners. Various forms of revolving brushes driven at a speed of from 500 to 800 r. p. m., through flexible shafts by electric motors of 1-3 to 1-2 hp., are employed, the apparatus as a whole being slung, according to requirements, from various kinds of portable attachments, with the aid of springs and counterweights.

DAILY LOCOMOTIVE-MILES ON ENGLISH RAILWAYS.—A daily run of nearly 400 miles is the performance of a locomotive operating between London and Liverpool, according to the Railway Gazette, London. The trains in both directions are exceedingly heavy ones and long distances are run without stopping. The interval between the out and home journeys is, comparatively speaking, a short one. It is stated that this is but one instance of many, and until comparatively recently there were cases of the same locomotive and enginemen working from Manchester to London, a distance of 183.5 miles, and from Leeds to London, 220.5 miles, and back as a daily trip.

RAILROAD ADMINISTRATION ACTIVITIES

Administration's Policy Outlined; Interchange Inspection; Safety Work; Orders of Regional Directors

USING the month the Director General has been in poor health and has found it necessary to arrange to spend the summer at White Sulphur Springs, Va. Although he will have an office at that point he will make frequent trips to Washington to oversee the work which he has detailed to his staff. In his absence, Walker D. Hines, assistant director general of railroads, will be in full charge.

Federal managers have been appointed to take charge of each property. The federal managers report to the regional directors, each of whom has a departmental organization of his own.

THE POLICY OF THE RAILROAD ADMINISTRATION

On June 15 the Director General gave out the following signed statement of the policy of the Railroad Administration:

"The policy of the United States Railroad Administration has been formed and shaped by a desire to accomplish the following purposes which are named in what I conceive to be the order of their importance:

"*First*, the winning of the war, which includes the prompt movement of the men and the material that the government requires. To this everything else must be subordinated.

"*Second*, the service of the public, which is the purpose for which the railways were built and given the privileges accorded them. This implies the maintenance and improvement of the railroad properties so that adequate transportation facilities will be provided at the lowest cost, the object of the government being to furnish service rather than to make money.

"*Third*, the promotion of a spirit of sympathy and a better understanding as between the administration of the railways and their two million employees, as well as their one hundred million patrons, which latter class includes every individual in the nation, since transportation has become a prime and universal necessity of civilized existence.

"*Fourth*, the application of sound economies, including:

- (a) The elimination of superfluous expenditures.
- (b) The payment of a fair and living wage for services rendered and a just and prompt compensation for injuries received.
- (c) The purchase of material and equipment at the lowest prices consistent with a reasonable but not an excessive profit to the producer.
- (d) The adoption of standardized equipment and the introduction of approved devices that will save life and labor.
- (e) The routing of freight and passenger traffic with due regard to the fact that a straight line is the shortest distance between two points.
- (f) The intensive employment of all equipment and a careful record and scientific study of the results obtained, with a view to determining the comparative efficiency secured.

"The development of this policy will, of course, require time. The task to which the Railroad Administration has addressed itself is an immense one. It is as yet too early to judge of the results obtained, but I believe that great progress has been made toward the goal of our ideals. All those who have had a share in this great work, including especially the members of my staff and the officers and employees of the railways, have shown intelligence, public spirit, loyalty and enthusiasm in dealing with problems that

have already been solved and attacking those that still await solution.

"With their continued co-operation, I feel assured of a future in which the lessons of our accumulating experience will be effectively employed to humanize the science of railroading and negate the idea that corporations have no souls."

INTERCHANGE INSPECTION

To the end that interchange inspection work may not be duplicated under government operation of railroads, so that more repair work will result, the Division of Operation has ordered, in Circular No. 7:

1. That joint arrangements shall be made to prevent such duplication in inspection by arranging all inspection forces at interchange points with a head or chief joint inspector as conditions require, to supervise the forces and see that inspection and repairs are properly made to cars.

2. Present M. C. B. Rule No. 2 is modified as follows:

(a) Loaded cars offered in interchange (except those having defective safety appliances) must be accepted by the receiving line, which may either run, repair or transfer lading from car.

(b) The repairs to car or transfer of lading is to be done by the railroad having facilities nearest available. If facilities are equally available by both railroads, the car will be moved to facilities located in the direction car is moving.

3. If car is shopped for repairs due to:

- (a) Old defects that existed before car was loaded—
- (b) Lading requiring transfer or readjustment on account of not being in accordance with M. C. B. Loading Rules—
- (c) Overload requiring transfer of lading—
- (d) Not being within clearance dimensions over route it is to pass—
- (e) Not meeting A. R. A. third rail clearance—

The facilities nearest to car will be used in making repairs to car or transfer of lading.

4. Should the location of facilities require a receiving line to make transfer, the delivering line will not be billed for transfer or readjustment of lading, but the chief joint or head inspector will make report and forward to the head of the mechanical department of both railroads. The railroad responsible for conditions making necessary the shopping of car for old defects or transfer of lading, will impose discipline for willful and inexcusable violation of M. C. B. Rules of Interchange and Loading, and A. R. A. Rules, the same as instructed in director general's Order No. 8, for violation of safety appliance law.

5. Cars whether loaded or empty having safety appliance defects will have such defects repaired immediately upon discovery and will not be offered in interchange. If necessary to move a car to shops for repairs of safety appliance defects, it must be moved to shops of the company upon whose line it became defective.

6. Empty cars offered in interchange, if in safe and serviceable condition, must be accepted.

7. Bad order cars which previously had been delivered in bad order under load must be repaired by the road making transfer, if it has facilities and material; if not, the nearest repair point on any line, having material and facilities, should make the repairs.

8. With these modifications, owners must receive their own cars when offered home for repairs at any point on their

lines where the repair facilities and material are available.

9. Such inspectors as are now engaged on duplicate work will be assigned to repair work so as to insure maximum safety of operation and prompt movement of traffic.

SUPPLEMENT TO THE WAGE ORDER

The Director General has issued the following Supplement No. 1 to General Order No. 27:

"The following will be added as general rules to Section F, Article II:

"(14) For positions created since December, 1915, the salaries will be readjusted so as to conform to the basis established in General Order No. 27, for positions of similar scope of responsibility.

"(15) Where wages were increased through arbitration or other general negotiations, which cases were definitely closed out prior to December 1, 1915, but which for any reason were not put into effect until after January 1, 1916, the increases fixed by General Order No. 27 will be applied to such basis of wages as if they were in effect in December, 1915."

BOARD OF ADJUSTMENT NO. 2.

In conformity with the provisions of General Order No. 29, Railway Board of Adjustment No. 2 has been constituted as follows: W. H. Penrith, assistant general manager, Chicago & Alton; E. F. Potter, assistant to general manager, Soo Line; A. C. Adams, superintendent of shops, New York, New Haven & Hartford; E. A. Sweeley, master car builder, Seaboard Air Line; W. S. Murrian, formerly superintendent of motive power of the Southern; Robt. J. Turnbull, inspector of transportation, Atlantic Coast Line; H. J. Carr, International Association of Machinists; George W. Pring, International Brotherhood of Boiler Makers, Iron Ship Builders and Helpers of America; G. C. Van Dornes, International Brotherhood of Blacksmiths and Helpers; F. H. Knight, Brotherhood Railway Carmen of America; Otto E. Hoard, Sheet Metal Workers' International Alliance; and F. J. McNulty, International Brotherhood of Electrical Workers. E. F. Potter, of the Minneapolis, St. Paul & Sault Ste. Marie, was chosen chairman, and F. J. McNulty, of the International Brotherhood of Electrical Workers, as vice-chairman. The board has designated the following dates as the beginning of each of its regular monthly meetings during the remaining portion of the year, 1918; July 2, Aug. 6, Sept. 3, Oct. 1, Nov. 5, and Dec. 3.

ORDERS OF REGIONAL DIRECTORS

SOUTHERN REGION

Circular Letter No. 243 states that each shop repairing foreign line locomotives will be expected to give such work the same supervision, inspection and workmanship that is given their own locomotives. Therefore the practice of sending inspectors to supervise repairs to locomotives at foreign line shops will be discontinued. It has been found to be of practically no value, and in some instances has actually resulted in delaying the repairs. When a locomotive is sent to a foreign line shop for repair the road sending the locomotive will furnish all necessary material for repairs; and will also furnish to the railroad which will make the repairs a detailed report of the work to be done, and a complete list of the material which is being furnished. The material shall in all cases be forwarded with or in advance of the locomotive. Inspectors at foreign line shops should be recalled and assigned to their regular work. The foregoing is not intended to apply to locomotives undergoing repairs at contract shops, or at the plants of locomotive builders, nor is it intended to apply to men who are specially assigned to work of collecting and forwarding necessary materials for repairs.

WESTERN REGION

Circular 121, dated June 6, orders that no contracts for repair of cars be placed at outside shops without first securing the approval of the regional director. The Car Repair Section is making an extensive inquiry and will be prepared to undertake necessary car repair work which cannot be done in the railroads' own shops.

Supplement No. 1 to Circular No. 121, issued on June 14, asks railroads to report the number of contracts with outside companies for repairing cars and the number of cars by classes undergoing such repairs. Copies of the contracts are also asked for together with a statement of the average cost per car for repairs on each contract, apportioned according to the cost of the labor, the material furnished by the contractor and the material furnished by the railroad to the contractor.

In a communication to western railroads on June 4, the regional director announces that railroads which have subscribed in the past to publications for the benefit of employees may continue in the same general policy but shall not radically increase or decrease number of subscriptions.

In Circular R. P. C. 14, dated June 8, the regional purchasing committee calls attention to the scarcity of tin and the necessity for conserving it to the fullest extent. The letter shows how less tin can be satisfactorily used in babbit and solder for railroad uses. The regional purchasing committee asks western railroads to report any experiments that may further conservation.

In a communication to western roads, dated June 12, the announcement is made that the Director General authorizes each of the railroads under federal control to purchase one membership in the American Society for Testing Material.

A communication, dated June 21, outlines the specifications for United States standard interchangeable electric headlight, which is being placed on all the standard locomotives recently ordered by the Railroad Administration. The blueprints and wiring diagrams are not yet available, but will be distributed shortly. Each headlight equipment will consist of one 300-watt, 32-volt turbo-generator, one micrometer lamp stand and one dimming device, the case to be air tight, round headlight case, No. 22 U. S. S. gage steel, with copper (32-oz.) triple-plated reflector, 18 in. in diameter and 9 in. deep, and an automatic circuit connector complete. The headlight will be of the incandescent lamp type, conforming to the requirements of the Interstate Commerce Commission in an order dated December 26, 1916. The socket for supporting the headlight will be located at the rear of the reflector and will support the headlight lamp in a horizontal position, so mounted that it can be moved in any direction with fine adjustment, to permit of focusing the headlight lamp and locking in any position. Suitable electric connections must be provided so that on removing the reflector from the headlight case the circuits will be broken automatically and, in replacing, it will be made automatically. A small unit incandescent lamp will be provided in the headlight case for illuminating the locomotive number. Headlight dimming resistance of rugged construction to withstand severe operating conditions will be provided with each turbine generator equipment.

EASTERN REGION

In a letter, dated May 21, 1918, A. H. Smith, regional director, commenting on Rules 29 and 31 of the Federal Locomotive Inspection Rules, regarding locomotive headlights, writes as follows to the presidents of Eastern railroads: "It is understood that some of the roads in Eastern territory are not complying with the provision of this order pending the outcome of court proceedings.

"The director general has instructed that the order should

not be modified, and that the railroads should proceed in good faith to carry out the terms of the order, i. e., that locomotives shopped for general repairs should be equipped with electrical headlights, that any new locomotive should be so equipped, and that the work should be followed diligently. Please be governed accordingly.

"If, after a trial, it is found that this work is adversely affecting shop output, or that headlights in sufficient quantities are not obtainable, the fact should be promptly brought to my attention.

"The locomotives which have been ordered by the Railroad Administration are all to be provided with electric headlights, conforming to the requirements of the Interstate Commerce Commission's order."

THE CAR AND LOCOMOTIVE SPECIALTY ORDERS

The Central Advisory Purchasing Committee of the Railroad Administration has ordered the principal specialties to be used for the equipment of the locomotives and the freight cars, ordered. In some cases the equipment is to be furnished or purchased by the builders, and in all cases formal orders will be placed by the car and locomotive builders with the specialty manufacturers. The list of the specialties so far ordered, which is practically complete, is as follows:

LOCOMOTIVES	
Air brakes	77 1/2 Westinghouse Air Brake Co. 250 New York Air Brake Co.
Brick arches	To be purchased by builders.
Radial buffers	Franklin Railway Supply Co.
Pilot bumpers	To be purchased by builders.
Cradle castings	To be purchased by builders.
Blow-off cocks	725 Everlasting, Scullin Steel & Iron Co. 800 Southern So. Loco. Valve Gear Co.
Boiler covering	To be purchased by builders.
Uncoupling devices	All engines, Imperial, Imp. Appliance Co.
Automatic fire doors	590 Shoemaker, Nat. Ry. Devices Co. 435 Franklin
Friction draft gear	All engine tenders, Westinghouse Air Brake Co.
Valve gear	590 Walschaert. 340 Baker. 185 Southern. 745 Ragonnet. 200 Lewis. 50 Brogan. 30 Mellish.
Headlight turbines and generators	All engines, Pyle Nat. Elec. Head. Co.
Steam gages	510 Ashcroft Manufacturing Co. 515 Ashton Valve Co.
Steam heat gages for passenger engines	90 Ashton Valve Co.
Water gages	All engines, Sargent Co.
Injectors	480 Nathan Manufacturing Co. 395 Hancock Inspirator Co. 150 Ohio Injector Co.
Check valves and stops	All engines, Nathan Manufacturing Co.
Lubricators	400 Nathan Manufacturing Co. 425 Detroit Lubricator Co.
Driving box lubricators	All engines, Franklin Railway Supply Co.
Metallic packing	535 Paston-Mitchell Co. 470 United States Metallic Packing Co. 150 Locomotive Stoker Co.
Coal pushers	65 Vanor. 25 Leslie.
Regulators for passenger locomotives	All engines, Harry Vissering & Co.
Bellringers	755 United States Metallic Packing Co.
Sanders	220 Hanlon Locomotive Sander Co. 50 Harry Vissering & Co.
Stokers	370 Duplex, Locomotive Stoker Co. 174 Standard Stoker Co. 35 Hanna Locomotive Stoker Co.
Switching and Pallet types take coal pushers.)	
Blower valves	All engines, Sargent Company.
Safety valves	640 Consolidated Safety Valve Co. 340 Coale. 55 Ashton Valve Co.
Brake shoe	All engines, American Brake Shoe & Foundry Co.
Grate shakers	All engines, Franklin Railway Supply Co.
Boiler tubes	To be purchased by builders.
Unit safety draw bar	All engines, Franklin Railway Supply Co.
Metallic connection between engine and tender	400 Franklin Ry. Supply Co. 185 Barco Mfg. Company. 140 Greenlaw Mfg. Co.
Stirrings	To be purchased by builders.
Throttle valves	All Chambers Valve Company.
Roller steel wheels	For all Steel Wheel Company. Standard Steel Works Company.
Coal sprinklers	540 William Sellers & Co. 495 Hancock Inspirator Co.
Wheels for tenders (cast steel)	All, Buckeye Steel Castings Co.

Side frames for freight engine tenders	American Steel Foundries. Buckeye Steel Castings Co.
Tender truck bolsters	All engines, Pittsburgh Steel Foundry Co.
Journal box for tenders	To be purchased by builders.
Side bearings for tenders	All, A. Stueckl Company.
Brake beams for tenders	All, Chicago Railway Equipment Company, except 170 to be furnished by the Baldwin Locomotive Works.
FREIGHT CARS	
Truck bolsters	45,000 American Steel Foundries. 21,000 Buckeye Steel Castings Co. 21,500 Scullin Steel Co. 8,000 Gould Coupler Co. 3,000 Bettendorf Co.
Couplers	23,000 American Steel Foundries. 15,500 Buckeye Steel Castings Co. 7,500 Gould Coupler Co. 8,000 McConway & Torley Co.
Side frames, cast steel	46,000 National Malleable Castings Co. 35,000 American Steel Foundries. 14,500 Buckeye Steel Castings Co. 16,000 Scullin Steel Co. 6,500 Gould Coupler Co. 28,000 Bettendorf Co.
Uncoupling device for couplers	All cars, Imperial Appliance Co.
Pressed steel ends	50,000 Pressed Steel Manufacturing Co.
Friction draft gear	50,000 Session Standard Coupler Co. 25,000 Westinghouse Air Brake Co. 19,000 Cardwell, Union Draft Gear Co. 6,000 Murray, Keyoke Railway Equip. Co.
Dust guards	All cars, Wm. N. Thornberg Co.
Air brake hose	To be furnished with air brake equipment.
Brake shoes	All cars, American Brake Shoe & Fdy. Co.
Draw bar yokes	30,000 American Steel Foundries. 50,000 Buckeye Steel Castings Co.
Air brakes	75,000 Westinghouse Air Brake Co. 25,000 New York Air Brake Co.
Brake beams	14,250 American Steel Foundries. 14,250 Chicago Railway Equipment Co. 14,000 Joliet Railway Supply Co. 14,000 Davis Brakebeam Co. 14,000 Damascus Brake Beam Co. 14,000 Buffalo Brake Beam Co. 8,000 Haskell & Barker Car Co. 7,500 Pressed Steel Car Co.
Steel ends for composite gondolas	12,000 Standard Railway Equipment Co. 8,000 Chicago-Cleveland Car Roofing Co.
Side bearings	40,000 A. Stueckl Co. 30,000 E. S. Woods & Co. 30,000 Wine Railway Appliance Co.
Journal boxes	32,500 Union Spring & Manufacturing Co. 38,875 National Malleable Castings Co. 28,500 T. H. Symington Co. 16,125 Gould Coupler Co. 4,000 American Malleable Co. 8,000 Haskell & Barker Car Co. 2,000 Pacific Car & Foundry Co. will secure on Pacific Coast.
Journal bearings	8,000 Haskell & Barker Car Co. 10,000 Boston-Lyon Bronze Co. 11,000 Southern Brass Company. 20,000 Keystone Bronze Company. Balance of Order to be placed later.
Wheels (steel)	3,000 Midvale Steel & Ordnance Co. 2,500 Forged Steel Wheel Company. 2,500 Carnegie Steel Company. 15,750 Griffin Wheel Company. 1,625 Brown Company. 1,625 Buffalo Car Wheel Fdy. Co. 2,600 Bass Foundry & Mach. Co. 2,000 New York Car Wheel Wks. 2,500 National Car Wheel Company. 1,000 Ramapo Iron Works. 1,000 Southern Wheel Co. 500 Standard Steel Works Co. 1,000 Albany Car Wheel Co. 500 Louisville Car Wheel & Ry. Sup. Co.
Wheels (cast iron)	7,000 Pressed Steel Car Company. 31,000 American Car & Foundry Co. 8,000 Haskell & Barker Car Co. 4,000 Mt. Vernon Car Mfg. Company. 2,000 Lenoir Car Works. 25,000 single sheathed box. Cannel Company 25,000 double sheathed box. Union Metal Products Company.
Door fixtures	Composite gondola and 55 ton hopper cars. Combination of car builders design with Enterprise safety lowering device. Murphy, Standard Ry. Equipment Co.
Roofs	17,000 Chicago-Cleveland Car Roofing Co. 16,500 Hutchins Car Roofing Company. 10,000 American Steel Foundries.
Springs	5,250 Crucible Steel Company. 5,500 Union Spring & Mfg. Co. 5,350 Pittsburgh Spring & Steel Co. 2,340 Ft. Pitt Spring & Mfg. Co. 52,000 Railway Steel Springs Co. 3,000 W. G. Mitchell Spring Works. 7,500 Pressed Steel Car Company. 7,500 Standard Steel Car Company. 1,500 Keith Ex. Locomotion Company.
Angle cock holders	All Railway Devices Company.
Ratchet head levers	For composite gondolas and 55 ton hoppers. 25,000 Robert H. Blackall. 20,000 Railway Wheel Company.

(The number in each case represents the number of cars or locomotives where two or three of a device is used on a single car or locomotive.)

The proposal which was tentatively advanced at the beginning of the negotiations with the specialty manufacturers

that they forego royalties on their patents or pool their patents was dropped.

AN UNUSUAL BOILER EXPLOSION

The reports of the chief inspector of locomotive boilers to the Interstate Commerce Commission show that in the six years covered by the statistics there have been 5 shell explosions, 335 crown sheet failures due to low water, and 19 explosions due to defective material, or water foaming. An explosion which will not fall strictly within any of these classifications is sufficiently unusual to merit notice.

The illustrations accompanying this article show two views of a locomotive on which low water caused the side sheet to fail, the crown sheet remaining in place. The locomotive was of the six-wheel switch type, with a narrow firebox. The crown sheet was practically flat and was supported by crown bars of a heavy T section and crown bar bolts with large heads. While operating in yard service the water level fell to a point about 18 inches below the crown sheet, resulting in the failure of the boiler as shown. The water line is clearly defined on the side sheet by the white horizontal line.

From an examination of the boiler it appears that some of the staybolts in the right side sheet near the upper front corner became overheated, together with the surrounding sheet, and pulled out. This caused a very great stress on the rivets connecting the wrapper sheet and the last course of the barrel of the boiler. The rivets at this point failed in tension, as can be seen by the character of the fracture. After the first rivets pulled out, the wrapper sheet was distorted, and the rivets in the barrel above the point where the initial failure occurred and those below in the throat sheet were sheared off. All the staybolts in the side sheet were either broken or pulled out. As the sheets separated the mud ring was pulled up and

staybolts. The back tube sheet was bent and pulled away from some of the tubes. Although the entire right side of the cab was demolished and the engineer was badly scalded



Wrapper Sheet Seam which Failed Due to Low Water

by the escaping steam, he recovered from his injuries. The fireman was not hurt.

The fact that the crown sheet did not drop shows that the application of crown bars with large heads on the crown



Wrapper Sheet Torn from Barrel Due to Low Water

broke about a foot from the front corner. A patch about 12 inches wide extended along the bottom of the wrapper sheet for the entire length of the firebox. This was broken close to the throat sheet, failure occurring at the row of flexible

bar bolts furnishes ample support for the crown sheet, even with extremely low water. However, it is a question whether failure of side sheets would not often bring more serious results than ordinarily occur when a crown sheet fails.



GAR DEPARTMENT

BRITISH AMBULANCE TRAIN FOR AMERICAN WOUNDED

If there were any doubts as to whether wounded American soldiers would be properly taken care of on their journeys by rail to the hospitals behind the lines in France, they have all been dispelled by the announcement made by Surgeon General Bradley with the American Army in France on January 6 that 15 complete hospital trains have been ordered in England and two in France for this purpose. The announcement followed the placing of the orders some time, for



Central News Photo

American Officers Inspecting the Accommodations

on December 29 the American ambassador, a number of United States Army and Navy officers and prominent Americans and Englishmen were able to inspect at the St. Pancras station in London, the first of the completed trains—one built in the car shops of the Midland Railway of England. In the Patriotic War Number of the Railway Age Gazette there appeared a description of one of the ambulance trains built for the British Government by the Great Eastern Railway, and emphasis was placed on the extreme care that the British have taken to make the railway journeys for their wounded as pleasant and restful as possible under the circumstances. The American train, illustrations of which are given herewith, likewise shows evidence of this British skill and care.

The complete train consists of 16 cars with accommodation for about 430 persons, there being 393 cots for wounded and facilities for the staff and personnel. Each car is 54 feet long, mounted on four-wheeled bogie trucks, and equipped with Westinghouse brakes. The couplings, draw hooks, steam connections and side chains are to the international

standard. The total length of the train, without engine and tender, is 913 feet, and its weight (unloaded) 435 tons.

Each car is built of well-seasoned timber and painted khaki color, with two large red crosses on a white ground on either side. For identification purposes, the number of each car and the distinguishing letter are conspicuous on each side, and the train number with the distinguishing letters U. S. A. T. is painted on the extreme ends of the train.

The train is vestibuled, and fitted throughout with electric lights and fans. The roofs are semi-elliptical, with high and airy ceilings. Every care has been taken to admit of the interior of the cars being kept clean with the least effort. The floors are covered with linoleum or lead, and have rounded corners. The gangways between the cots are wide enough to pass the army stretcher. An abundant supply of water (2,835 gal.), apart from the drinking water, is carried in tanks built in the roof.

In addition to the equipment for heating the train by steam from the engine, the Staff car *B* and the Personnel car *C* have each a separate, self-contained circulating hot water apparatus for use when the engine is not attached.

The order of cars on the train is as follows:

A-10—Brake and "lying" infectious ward car.

B—Staff car.

D-1—Kitchen car (with officers' compartment).

A-1, A-2, A-3, A-4—Ward cars (four).

F—Pharmacy car.

A-5, A-6, A-7, A-8, A-9—Ward cars (five).



Sick Officers' Day Saloon

D-2—Kitchen car (with N. C. O.'s and men's compartment).

C—Personnel car.

E—Brake and stores car.

The brake and lying infectious ward car (A-10) contains four wards, each fitted with six beds, an attendant's compartment with lavatory and toilet accommodation, and a

guard's compartment with bed, folding table and seat, lavatory, etc., in addition to the usual brake equipment.

Staff car *B* contains dining room and sleeping compartments for the medical officers and nurses and lavatory and toilet accommodation, including side sprays. This car is also furnished with wardrobes, cabinets and book racks, and is finished and panelled throughout in polished mahogany.



Central News Photo

One of the Nine War Cars

Kitchen car *D-1* contains an officers' pantry and cook's room, with three sleeping berths, dining table, seats, etc. The kitchen, which is a spacious compartment, is fitted with an army "Dixie" range with hot water supply, and a "Soyer" stove. A comfortably furnished sitting sick officers' compartment forms part of the kitchen car, having wood linings and tables of polished mahogany, and the seat coverings of moquette, with a lavatory compartment adjoining. A bath

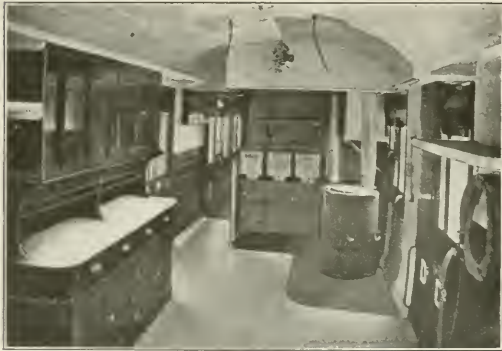

The Kitchen Car

room is also provided in this car, containing a 4 ft. 6 in. bath, which is fitted with hot and cold water and shower bath.

The nine ward cars are open throughout, with a lavatory compartment at one end. Each car contains 36 folding cots, in three tiers, the cots in the middle tier being so arranged that they can be folded down to form backs for sitting cases on the lower tier. An ample supply of drinking water and conveniences such as paper racks, ash trays, etc., is provided for each patient. The sides and roofs of these cars are painted in glossy white enamel

Pharmacy car *F* contains a dispensary, and treatment medical officer's office, linen room, and a pantry for medical comforts, and an emergency compartment. The corridor on this car is wide enough to pass a stretcher into the treatment room. The dispensary is fitted with cupboards and racks for bottles, surgical dressings, etc. Part of this car is partitioned off and provided with eight berths, in which bad cases can be treated.

Kitchen and men's mess car *D-2* contains a large kit store, wash basin, and kitchen similar to that on car *D-1*, a mess room, with folding table for the men, and a smaller mess for the non-commissioned officers, the latter having two beds, so that the senior N. C. O.'s may sleep there if desired.

Personnel car *C* is arranged similarly to the ward cars, except that the mattresses of the beds are covered with Ameri-



Copyright by Underwood & Underwood, N. Y.

War Car Arranged for Sitting Cases

can cloth, so that the beds can be used as seats by the staff during the day. Kit racks are provided, and also small lockers under the beds.

Brake and store car *E* contains a large linen store and a compartment provided with shelves for carrying the general provisions required on the train, a kit store and compartment for perishables and a meat safe. A brake compartment similar to that on car *A-10* completes the car.

A STATEMENT OF THE PURPOSE OF THE M. C. B. ASSOCIATION*

BY JOSEPH W. TAYLOR

Late Secretary of the Master Car Builders' Association

The Master Car Builders' Association, in its beginning a voluntary organization, composed of master car builders and foremen of railway car shops, was formally organized at Altoona, Pennsylvania, September 18, 1867. Previous to this, and dating back as far as 1864, several informal meetings had been held by the car men of the New York Central, which were attended by the master car builders of a few of the nearby roads. At the meeting referred to, 41 master car builders were present, when a constitution and by-laws were adopted.

The objects of the association are the advancement of knowledge concerning the construction, maintenance and service of railroad cars and the parts thereof, by investigations through committees and discussions in convention; to provide an organization through which the members and the companies they represent may agree upon such joint

* The information contained in this statement was prepared for the Railroad Administration by Mr. Taylor shortly before his death.

action as may be required to bring about uniformity and interchangeability in the parts of railroad cars; to improve their construction and to adjust the mutual interest growing out of their interchange and repair, but the action of the association shall have only a recommendatory character, and shall not be binding upon any of its members or the companies represented in it.

The reasons for the formation of this organization may be stated as follows:

Prior to the date of the organization cars were confined almost, if not entirely, to the roads for which they were built and to which they belonged. The inconvenience of transshipping freight when carried long distances soon made it necessary to run cars over more roads than one, and as the demand for carrying freight further without breaking bulk increased some improvement was necessary in order to carry it without unloading and as rapidly as possible. This brought into existence different express or fast freight lines which operated over two or more roads in different sections of the country. It was soon found that difficulties were constantly occurring in regard to the repairs of these cars, and that they were often delayed when far away from home by not having the right kind of materials on hand to replace broken parts. Some plan had to be devised to obviate the evil, and as the master car builder was deeply interested in the physical condition of the car, an organization of these men was effected to take care of the prompt repairs of the cars.

Up to the year 1882 the organization was wholly voluntary. It received no financial support whatever from the railroad companies which were the owners of the property intrusted to the care of the master car builders, and the improvement of which was the chief subject of consideration and discussion at their meetings, the expenses of the organization being met by assessments on the individual members. Neither were the railroads directly represented in the association, excepting by such exertions in behalf of their employees as the master car builder might choose to make, if he were a member. It was therefore thought that if the association was so organized that each railroad company could be represented by a vote in its deliberations proportionate to its interests, or, in other words, to the number of cars it owned, and if the work which the association had done and should do was adequately explained and understood by the chief executive officers of the railroads of the country, that they would be inclined to co-operate with the association and assist in its work. An amendment to the constitution was therefore introduced at the convention in June, 1881, the purpose of which was to create a new class of members, to be called "representative members" with the status and privileges indicated above.

As stated above, the proposed plan of reorganization of the association was submitted to the chief executive officers of the railroads of this country, Canada and Mexico, and received practically the unanimous approval of these officials, and at an adjourned meeting held at Niagara Falls, New York, on October 10, 11 and 12, 1882, the proposed reorganization was ratified and adopted.

At the present time the membership of the association is as follows:

Active	454
Representative	468
Life	19
Total	941

The number of cars represented in the association is, practically 2,800,000 cars, the cars of Canadian and Mexican railways being included. Its membership extends to England, France, Russia, India, Australia, Japan, China, Argentina, Chili, Brazil, Cuba and the Philippines, officials of railroads in those countries wishing to avail themselves of

the information contained in its proceedings relating to the construction and operation of cars.

As a result of the reorganization in 1882 the scope of the work of the Association developed and broadened materially. Through the financial support furnished by the railroad companies, investigations and tests of practically every part of a car have been, and are constantly being carried on, to furnish equipment of the necessary strength and designs to meet adequately the varying requirements of the traffic of the country.

The question of uniformity in the construction of cars whereby the parts of cars used by one railroad may be used in repairs of the cars of any other road has been constantly before the Association. As an indication of what has been accomplished in this direction, the following comparison of the number of parts necessary to keep on hand for repairs at the date of reorganization (1882) and the present time is cited:

	1882	1918	
Axles	56	5]
Journal boxes	58	5]
Couplers	26	2	
Brake shoes	40	1	
Brake heads	27	1	

The parts enumerated above are only a few of those used in the repairs of cars, but if they were all named, it would increase the list to enormous proportions. A similar condition of things to that indicated above exists wherever any considerable number of cars are interchanged between railroads.

Among the more important developments made by the Association, may be mentioned the adoption in 1887 of the automatic coupler for cars, thus doing away with the link and pin coupler and the necessity for going between cars to couple them together.

Another noted achievement was the adoption in 1888 of the automatic air brake as the standard of the Association. Today, practically every car in the country is equipped with this device.

Following its adoption, a code of instructions for the proper operation of the air brake was prepared and generally distributed among railway employees.

Through the activities of the different committees and their investigations and studies, standards for 62 different parts of cars have been adopted by the Association.

Other parts of cars are being studied and while no definite standards have been adopted, certain forms of recommended practice have been submitted to the members for investigation and trial, with the expectation that they, or some modification of them, will finally be adopted as standard and become the universal practice of the railroads.

The railroad car of today is simply a vehicle of transportation, no matter by what railroad it is owned. The object of the railroads today is to furnish a vehicle suitable for the lading, and transport that lading to destination as expeditiously as possible. The railroad car is subject to very severe handling in trains and certain defects naturally develop which need to be kept in repair. To take care of this condition, this association has formulated and maintains rules for the interchange of traffic, insofar as they relate to the physical condition of the car, so that the traffic itself may not be delayed. By these rules of interchange the immense movement of traffic between railroads is carried on with a minimum of delay due to the defective condition of the car.

The aim of the association through these interchange rules is:

(1) To establish rules which will uniformly permit of the prompt interchange of traffic between the various railroads without undue delay to the shipment of the car, which might be brought about by a difference of opinion between the receiving and delivering line as to responsibility for the physi-

cal condition of the car or the method of loading on open top cars.

(2) To provide through allowances, as given in the rules, prices to be charged for materials, detail times for completing the various items of repairs and a uniform labor rate per hour.

(3) Uniformity in compiling charges as between car owners for the maintenance of the equipment of the country.

(4) Fixed allowances to enable car owners properly to check bills for car repairs made against them by other handling companies.

(5) To provide methods for reimbursing car owners for the destruction or damage to their cars by other handling companies.

(6) The compulsory use by car owners of detail standards of construction as brought about through the operation of the rules, so that when the association feels that certain standards of construction are necessary for the safe operation of cars, they will not be permitted to be interchanged without the use of these standards.

(7) In 1887 an Arbitration Committee was established for the settling of disputes arising under the rules between members of the association in reference to a correct understanding of the rules with reference to car maintenance and also as to correctness of charges. During this period 1,133 cases have been arbitrated.

The association has promulgated rules for the loading of materials on open cars, thereby preventing the shifting of loads in transit and the consequent accidents therefrom.

The safety appliances approved by the Interstate Commerce Commission are our standards and the rules governing them are distributed to our members.

The association, working in conjunction with the Bureau of Explosives, has developed a series of specifications for the construction and operation of tank cars. The first specifications were prepared in 1903, and were principally for wooden underframe cars having tanks tested to but 40 lb. per square inch, and therefore, under the Interstate Commerce Regulations could not be used for the transportation of inflammable liquids with flash points below 20 deg. F. The next step was the development of a tank car for the handling of volatile inflammable products, to withstand a test of 75 lb. per square inch. The final development is a tank car for the transportation of such liquids as chlorine and sulphur dioxide, to withstand a test of 300 lb. per square inch. Tests of these tanks and their safety valves must be certified to the Bureau of Explosives before they are permitted to be used in service.

The income of the Association is derived by the assessment of the active members on the basis of \$5 per year, and the representative members, or those appointed by the executive officer of the railroad, on the basis of \$6 per 1,000 cars represented in the Association.

While the Association's activities are along the lines of the construction, maintenance and service of railroad cars, it also keeps in close touch with the Interstate Commerce Commission, the Bureau of Explosives, and also with other railway organizations, such as the American Railway Association, the Association of American Railway Accounting Officers, the various transportation associations, in its efforts to maintain the rolling stock equipment of our railroads in the highest state of efficiency.

In conclusion, it is respectfully submitted that to facilitate the movement of traffic, to handle the traffic safely, not only in reference to the movement of the load itself, but also to safely operate the railroads as a whole, to improve car construction, to allocate responsibility for freight car maintenance, a set of rules such as has been already developed is necessary. To apply such rules effectively an organization is necessary which should have sufficient flexibility in its authority to meet changing conditions promptly; the Master Car Builders' rules and organization provide the necessary vehicle for accomplishing such purpose.

PASSENGER CAR TERMINAL REPAIRS*

BY C. V. FRYER

General Foreman, Car Department, New York, Ontario & Western

The passenger car terminal yard bears the same relation to the car shop that the roundhouse bears to the locomotive shop. It is the inspection point where a decision is made whether to make repairs or send the car to the shop. In some cases the foreman will send cars to the shop for some minor repairs, which should be attended to at the terminal. All light repairs, such as changing wheels, repairs to trucks, draft gear, air brake, steam heat and lighting equipment, that could be repaired in a few hours, should be taken care of at the terminal repair yard, also all light repairs to the interior, such as lamps, seats, watercoolers, hoppers (flush or dry), door locks, trap doors, window glass, sash balances, etc.

The terminal stock room is of considerable importance. It should be under the charge of an experienced car man if the terminal is large enough to warrant one; if not it should be under the supervision of the foreman, or the "handy man," that fellow who can turn his hand to most any kind of light repairs. He can be found in nearly any car repair shop. He should be transferred to the terminal yard and given a good rate, as he is a valuable man to the foreman and a big saver of time and material for the company.

The terminal foreman should be supplied with a record of all different series of cars, with a description of the fittings and appliances, size of journals and wheels, kind of draft gear and names of parts, kind of uncoupling apparatus, coupler, centering devices, side bearings and center plates, also the names of the interior fittings, such as hoppers, basket racks, sash balances and locks, door locks, seat fittings, etc.

Much could be said about the layout of a terminal repair yard. It should have a good water system, a good steam heat and compressed air plant, a drop pit for removing wheels, a vacuum cleaning system, and a work shop for carpenters, tinsmiths, blacksmiths and pipe fitters.

The organization should be headed by a live foreman who understands car repairing in all its branches, and should have the necessary number of repair men and men who understand steam heat and air brake work. The size of the organization will depend, of course, upon the number of cars handled.

On the arrival of a train in the repair yard, a careful inspection should be made to see if any repairs that will require any car being switched out are necessary. Special attention should be given to steam heat, air brakes, trucks, draft gear and journal packing. The interior should be thoroughly looked over for loose seats, screws projecting from fittings and seat backs, water coolers should be thoroughly cleaned by scalding with steam, toilets scrubbed and disinfected, floors scrubbed, seats and backs dusted, the car wiped and windows cleaned inside and outside. To keep the good will of the traveling public, keep your cars clean.

MAGAZINES FOR SOLDIERS.—In the office of the station master at the Utica Union Station there is a great pile of magazines and reading matter. This literature was sent there by the Utica Public Library, which has been steadily collecting such material for some time, and the railroad men see to it that every troop train which passes through Utica is supplied with several bundles of the magazines. The Utica Herald-Despatch says that this is an excellent work, and the railroad men and the library are both to be congratulated.

*Presented at the convention of the Chief Interchange Car Inspectors' and Car Foremen's Association.

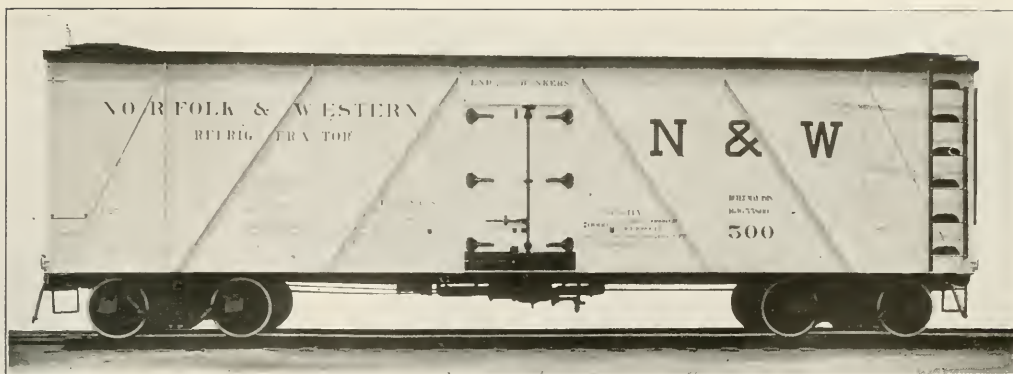

STEEL FRAME REFRIGERATOR CARS

Norfolk & Western Design Has Bunched Insulation,
Insulated Bulkheads and Conduit Floor Racks

BY E. G. GOODWIN

THE Norfolk & Western is constructing in its Roanoke (Va.) shops, as samples and for experimental purposes, ten refrigerator cars designed to meet, both scientifically and practically, all of the requirements in the transportation of perishable freight. Although these cars are just being constructed, the design was prepared in 1916, and as these are the first refrigerator cars built by the Norfolk & Western, a thorough study of the subject was made from every point of view, both theoretical and practical.

An investigation of the design of a large number of re-

frigerator cars showed that in the majority of cases many of the fundamental and well established principles of refrigeration and mechanics were entirely neglected. Perhaps the most notable deficiency in this respect is in the matter of the proper directing of the air currents. The keynotes of a successful refrigerator car lie in proper air circulation and insulation. It should be understood at the outset that ice meltage serves not only in lowering the temperature of the

air inside of the car but that it furnishes also the motive power by means of which air circulation throughout the car may be obtained if the car is correctly designed. The solid bulkhead with which these cars are equipped provides an air leg or chimney, from the top and bottom of which it is both reasonable and practical to carry out conduits in such manner as to give circulation with uniform tem-



Completed Interior of the Car with the Usual Type of Floor Rack

peratures throughout the entire car. At the floor this is obtained by building the floor racks not only to provide the customary protection for the lading from damp floors, but to form an air conduit for the flow of cold air out to the center



Interior of the Car after the Application of the Sub Floor and Outside Sheathing

peratures throughout the entire car. At the floor this is obtained by building the floor racks not only to provide the customary protection for the lading from damp floors, but to form an air conduit for the flow of cold air out to the center

of the car. The warm air returns over the top of the lading and into the top of the air leg.

The distribution and method of application of insulation have undergone considerable change in the last few years. Experience has shown that by far the greater transmission of heat takes place through the ceiling, due to the more direct rays of the sun. It is also established that the insulation below any possible water line should be waterproof and little affected as to its insulating value if allowed to become wet. The customary dead air space between successive layers of insulation is practically worthless and in many cases a disadvantage, as it often becomes a circulating space, rendering the outer portion of the insulation useless. The more practical method of bunching the insulation is preferred, especially because the insulation is so easily supported to withstand the shocks of ordinary service, the smaller space required and the elimination of all air currents within the walls themselves.

As a result of the preliminary study, some of the objects sought in the design were: An all steel frame sufficiently strong and rigid to prevent material deflection or wearing; means for holding the ice away from the car walls to reduce melting from the convection of the outside heat; unrestricted

10,000 lb. of ice, with a minimum space between the ice bunkers of 2,000 cu. ft.

With the above specifications the cars were designed to the following general dimensions:

Length between bulkheads	33 ft.	4 5/8 in.
Length over end sheathings	44 ft.	1 in.
Length over end sill channels	45 ft.	1 1/2 in.
Width inside	8 ft.	4 1/2 in.
Width over sheathing	9 ft.	1 3/4 in.
Width over steel framing	9 ft.	8 in.
Width over eaves	6 ft.	11 1/4 in.
Height inside, floor to ceiling	7 ft.	8 1/4 in.
Height of floor racks	5 in.	
Height of floor from top of rail	4 ft.	9/16 in.
Height of running board	13 ft.	4 5/8 in.
Maximum height of car to top of brake shaft	13 ft.	10 3/4 in.
Width of door opening	4 ft.	3 in.
Height of center plate	2 ft.	3 5/8 in.
Truck centers	31 ft.	
Truck wheel base	5 ft.	
Size of journals	5 in.	by 9 in.
Size of ice bunkers, each	5 in.	132.5 cu. ft.
Capacity } Lading		60,000 lb.
		10,000 lb.
Light weight		55,800 lb.

STEEL FRAMING

In view of the fact that the frame is the most essential part of the entire car from the standpoint of permanence and dura-

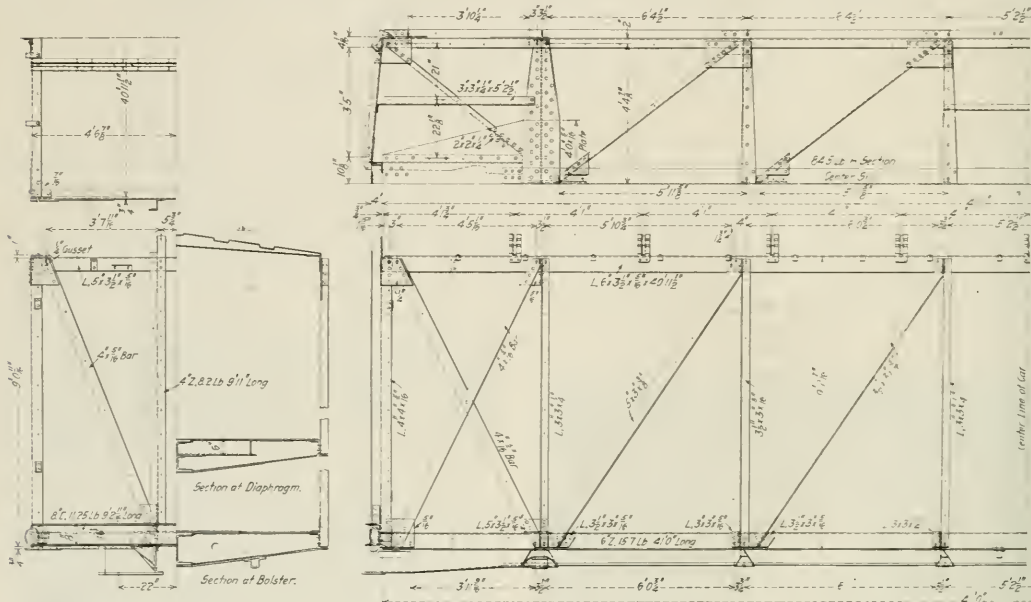

General Arrangement of the Steel Body and Underframe

and properly proportioned passages for the air currents with ample contact area between the air and ice; a solid, insulated bulkhead to provide an air chimney and to prevent localization of refrigerating effects.

In view of the difficulty of obtaining a load of any material weight with most of the perishable goods in a car of reasonable cubical capacity, 60,000 lb. is probably the most practical capacity to which a refrigerator car should be built, but in the case of such a car, where the tare weight is so great, the standard 30-ton car trucks are not capable of carrying the dead weight of the car and 30 tons of lading. The next larger standard truck is required, which is a 40-ton car truck with five-inch by nine-inch journals. It was considered economical and practical, therefore, to proportion the parts of the car to carry possible loads representing the full capacity of the trucks, making a 70,000-lb. capacity car, including

ability, it was given first consideration. Steel shapes either rolled or pressed were used throughout, and so arranged as to allow the minimum deflection in either direction. Special consideration was given the construction of the center sill, for which a Bethlehem H-section, weighing 84.5 lb. per ft., is used.

Horizontal buckling of this sill due to buffing is resisted by the entire underframe, which is a truss within itself, bringing into action the pressed steel diaphragms, channel section diagonals and Z-bar side sills, while vertical buckling is resisted by the side frame trusses, acting through the diaphragms. Pressed steel draft sills which take the pull only are attached indirectly to the center sill by means of a steel back-stop casting, and are fitted with the Sessions type K draft gear with the Farlow one-key draft attachments. The bolsters and diaphragms are made up of 3/4-in. plates flanged

of $\frac{1}{2}$ -in. hair felt between two fir ceilings, $\frac{13}{16}$ in. thick above and $\frac{9}{16}$ in. thick below; these extend lengthwise of the car for its full length and width, and are fastened to the oak carlines above with long wood screws. The weight of the ceiling is also supported by the side walls which are later

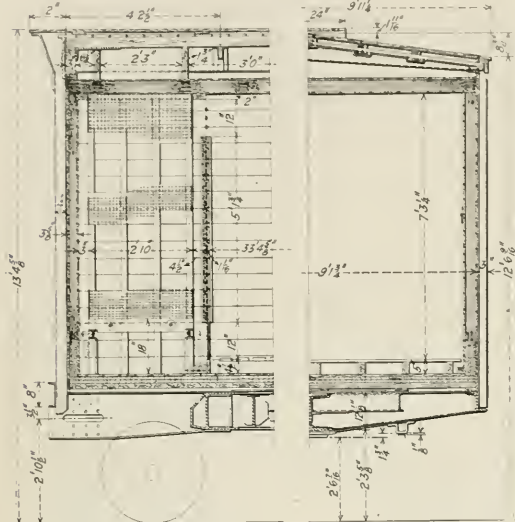

Longitudinal Section Through the Ice Bunker and Half Cross Section of the Car Body

built under its edges, an arrangement playing some part in maintaining a tight joint along the eaves. The securing strips for the different layers of hair felt alternate, first between the carlines and then directly under them. This method of support gives sufficient room for $\frac{1}{2}$ -in. strips by simply

while shorter screws, put in from the top, clamp the two wood ceilings at the intermediate strips. The latter screws, however, do not reach entirely through the lower wood ceiling.

The side walls are built in much the same way. The first layer of hair felt, reaching from the side door post around the end of the car to the door post on the opposite side, is unrolled in place and fastened to the siding with false nailing strips, placed vertically, two between adjacent side stakes. The second layer, exactly covering the first, is then put up and heavier strips placed directly opposite the side stakes are permanently bolted in place, using every second hole in the framing members. The temporary wood screws occupying these holes are removed as the bolts are inserted.

The third layer is applied like the first and the fourth like the second, except that nailing strips thick enough to hold the inside lining away from the insulation about one inch are located both at the side stakes and over intermediate nailing strips. This space is to prevent the waterproof paper



Interior of the Car Showing the Completed Side Wall Insulation and Method of Sealing the Joint at the Floor

covering of the insulation from becoming perforated by nails sometimes used by shippers to secure the lading in position.

As the hair felt is quilted between two layers of waterproof paper this makes a total of two inches of hair felt and eight thicknesses of paper in the side and end walls while three inches of hair felt and thicknesses of paper, or 50 per cent more insulation is used in the ceiling.

The side insulation extends within 12 in. of the floor. From this line down the insulating material consists chiefly of cork, which is preferred on account of the possibility of water getting into the floor or lower portion of the walls, where it would render the hair felt practically worthless. However, every means has been provided to prevent such an occurrence. The first layer of 1 in. cork boards in the floor is continuous, having the joints between the pieces cemented together with a flexible asphalt applied hot, while 1-in. by 4-in. floor nailing strips are inserted and cemented into the second layer with the same material. The cork ex-

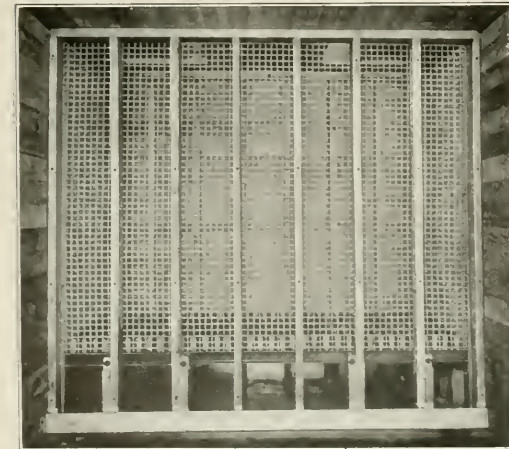

A View of the Ice Bunker Before the Application of the Bulkhead

compressing the hair felt at the strips, leaving it expanded to its normal thickness elsewhere. Each layer of insulation in the ceiling is in one piece, turned down around the edges and stripped. After the $\frac{9}{16}$ -in. lower ceiling is applied, long screws are driven through the ceiling into the oak carlines,

tending 12 in. up the walls is also set in hot asphalt thereby sealing the joint between the floor and sides. Over all of this and immediately under the top floor is placed a heavy but flexible asphalt-coated burlap plastic extending up the side and end walls above the cork and interlapping with the hair felt, which helps to waterproof the floor and still further seal the joint at the floor line. The top floor is of 13/16-in. yellow pine and floats on the cork.

The hatch plug although of ample size is light and effective, being practically all insulating material set in a substantial wood frame. Six layers of 1/2-in. hair felt are used in the body while the edges are fitted with two layers covered with a heavy canvas.

One feature not to be overlooked is the fact that there are no bolts, screws or nails used in any part of these cars passing through an insulated portion which have both ends

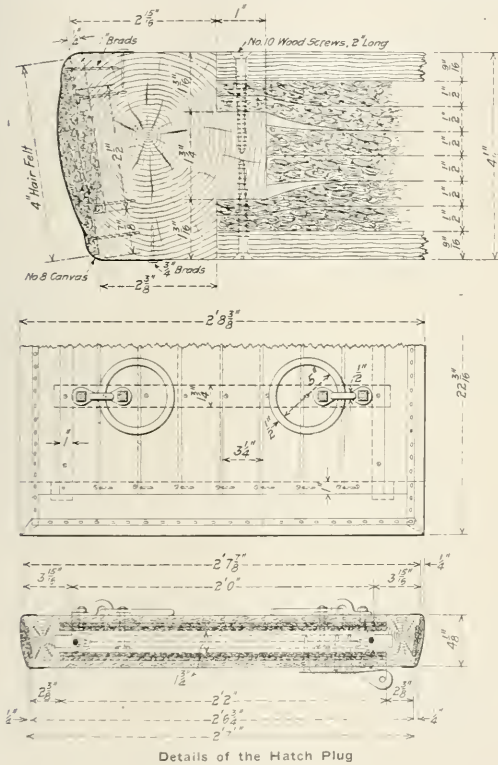

exposed. It is considered poor practice to employ insulating material, then pierce it with metal heat conductors. Leaky joints, especially along the edges of the floor and ceiling as well as around the hatch plug, door and door post have been guarded against, as may be seen in the illustrations.

The bulkhead, which is insulated with two layers of 1/2-in. hair felt, is framed of oak and secured to the floor and ceiling to resist shifting of the lading.

The ice bunker is the wire basket type with a 3-in. air-space on all sides. This allows ample contact between the air and ice and gives an unrestricted passage for the circulating air. The ice grate is built up of oak bars bolted together. Three sections are provided for each bunker and they rest loosely on the grate bearers, rendering cleaning of the drip pans or renewing the grates an easy matter.

While most of these cars are being equipped with the usual type of floor racks made in eight sections five inches high throughout, others have been fitted up for comparison with a new design of rack which is lighter, more durable and has several other advantages. This rack is made in four sections and decreases from 5 in. high at the bulkheads to 1 1/2 in. at the edge of the door. It forms a theoretically correct conduit, gradually diminishing in its cross-sectional area as the cold air is led off through the lading. To make it practical the rack is not carried out to the theoretical feather edge, but is cut off at the door post and a renewable wearing pad fixed to the floor between the doors. This eliminates the troublesome flexible end ordinarily used, permits trucking the lading through the cars and renders cleaning easy. It also has a tendency to resist shifting of the lading against the bulkheads. This construction serves to keep the cold air from flowing in a body to the center of the car, where it might pass up through a vertical vent left in load, with the result that the amount of heat absorbed would be less and the circulation retarded.

These plans were prepared under the direction of W. H. Lewis, superintendent motive power, and John A. Pilcher,

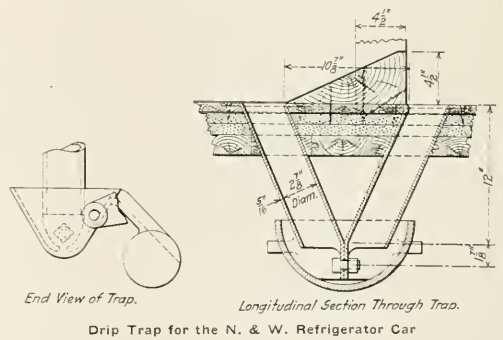

mechanical engineer, of the Norfolk & Western. Advantage was taken of the experiments conducted by the Food Research Laboratory of the Agricultural Department through the co-operation of Dr. M. E. Pennington, who has approved the design.

THE PACIFIC COAST PORTS are rapidly becoming the favorite route for merchandise bound to or departing from the United States, says a bulletin of the National City Bank of New York. The share which the Pacific ports handled of the import trade of the United States in the nine months ending with March, 1918, was 22 per cent against only 12 per cent in the corresponding months of 1917, while the share handled by the Atlantic coast ports was 56 per cent against 68 per cent in the corresponding months of 1917.

ENGLISH RAILWAY INVITES SUGGESTIONS.—The London & North-Western Railway has issued a notice in its Crewe works that the company will welcome suggestions for the improvement in methods of manufacture or carrying out work which occur to any of its staff, and in the event of any such suggestion being made use of by the company, and found beneficial, a suitable acknowledgment will be made, and, if desirable, assistance will be rendered towards the patenting of the same, under the usual conditions appertaining to patents taken out by employees of the London & North-Western. In conformity with the notice the directors have recently granted a reward of £5 (\$25) to a man in Crewe works for suggesting an improvement to the machine on which he was engaged.—*The Engineer, London.*

FREIGHT BRAKE MAINTENANCE*

Properly Maintained Efficient Freight Brakes are Vital to a Solution of Present Transportation Problems

BY F. B. FARMER

Northwestern Representative, Westinghouse Air Brake Company, St. Paul Minn.

TO help win the war is the highest ambition of every loyal railroad man. All other interests are secondary and the best way to help is for all to co-operate in securing the safe and expeditious movement of trains. Passenger trains must be moved and promptly, but it is especially necessary that freight trains and locomotives be so maintained and operated that the maximum possible gross ton-mile capacity may be realized. As all train movements are absolutely dependent on efficient air brakes, the importance of proper freight brake maintenance will be readily appreciated. It is the purpose of the following article to show, first, that freight brake maintenance is generally unsatisfactory, second, why it is unsatisfactory, and third, how it may be improved.

PROOF OF UNSATISFACTORY CONDITIONS

Several years ago two representatives of the Westinghouse Air Brake Company and two railway air brake experts, after giving particular attention to freight train break-in-tows, became convinced that freight train brakes in interchange service were not being maintained as well as the needs and the time and money spent on them would warrant. In order to prove their contention beyond reasonable doubt, a "dead line" division point on a certain road was established at the top of a descending grade and freight train brakes were tested at this point with a 20-lb. continuous service reduction from 70 lb. It was required that all brakes must apply and remain applied during the 12 or 14 minutes needed to inspect the entire train and any car that would not stand this test was set out for repairs.

A 20-lb. continuous service reduction from 70 lb. should produce approximately 50 lb. pressure in the brake cylinder but brake pipe leakage causes more air to leak in from the auxiliary reservoir during the inspection and since five or six pounds will hold the brake cylinder piston in applied position the test requirement indicated above was very moderate. No test of the retaining valve was included and no air brake was considered ineffective unless entirely off when inspected. In spite of easy test requirements, however, 10 to 12 per cent of the cars inspected had to be set out for repairs. A particularly disturbing feature noted was the short time a large proportion of the defective brakes, as indicated by the stencils, had been put in good condition.

The seriousness of this condition is well illustrated by the following table, which shows the number of defective brakes on system cars during the month of July for 1913, 1914 and 1915, together with the percentage of brakes found defective after one, two, three, etc., months of service from the last cleaning date, as shown by the stencils:

Month of July for re-cleaned	Number of brakes	Percentage of system cars re-cleaned according to the number of months service from last cleaning date												
		1	2	3	4	5	6	7	8	9	10	11	12	
1913....	596	21.3	35.7	44.7	51.9	56.9	63.0							
1914....	893	18.9	28.1	36.2	43.0	48.2	52.6	58.4	65.1	76.1	84.9	93.5	96.9	
1915....	630	8.8	16.1	23.8	30.9	36.3	44.6	47.7	54.1	65.2	75.7	85.4	95.4	

These brakes were repaired at the "dead line" point. A record of the system cleaned brakes only was taken, because it was desired to improve the work of the particular road referred to. While the table shows an improvement in condition, it also shows the possibilities remaining after two

years of special and unusual work done to improve the condition of the brakes. The foreign cleaned brakes on this road showed a much worse condition. A check made in October and November, 1917, showed that of 1,103 system cars, 14.1 per cent had defective brakes, as compared with 25.3 per cent on 659 foreign cars. During 1914 the average time a car ran before being re-cleaned was 6.6 months. For 1915 this was increased 7.5 per cent to 7.1 months. It will be noted that in 1913, 44.7 per cent of the defective brakes were inefficient three months after cleaning, which was decreased to 23.8 per cent in 1915. This creditable showing was the result of establishing but one "dead line" and that operating in one direction only. Although a special effort was made in 1914 to improve conditions and encouraging results were obtained as shown in the table, a gage test for brake cylinder leakage made at various division terminals in 1915, showed that out of 164 freight brakes tested immediately after cleaning, 52 leaked down over five pounds in one minute.

The customary method of lubricating had been followed, which included filling the expander space next to the inside of the packing leather with lubricating grease. This temporarily stops or reduces leakage through a defective packing leather, and the unfavorable results stated were minimized. To demonstrate this fact, a special gage test was made of a packing leather that the average cleaner would judge by inspection to be good, but which in reality was very porous. With a dry surface on the expander side and a lubricated cylinder wall, it leaked 38 lb. from 50 lb. in one minute. This was reduced to seven pounds leakage by filling the expander space with lubricant. After being under a pressure of from 50 lb. down to about 30 lb. for 90 minutes, the leakage had increased from 50 lb. down to 37 lb. This showed that the lubricating grease on the porous part of the packing leather had been forced through.

Reverting to the gage tests, 12 brakes just cleaned leaked up over three pounds from 50 in one minute, due to faults in the triple valves or their gaskets and in this test a limit of three pounds leakage should certainly not be exceeded. From excessive cylinder leakage and other causes 40.6 per cent of the 64 brakes tested were found defective immediately after cleaning.

A gage test of 76 brakes that were selected at random in 1917 after having run three months from the date of cleaning, showed the following leakage from 50 lb. in one minute:

71 per cent leaked over 5 lb.
79.2 per cent leaked over 10 lb.
40.7 per cent leaked over 15 lb.
21 per cent leaked over 20 lb.

Regarding the present general condition of freight brakes in interchange service, terminal tests and inspections show that due to the establishment of "dead line" points, there is a noticeable improvement in air brake equipment, as compared with 1915. There is great need, however, for further improvement because of 2,276 cars recently examined, 14.1 per cent with inefficient brakes had to be set out for repairs.

CAUSES OF POOR BRAKE MAINTENANCE

The "dead line" data given above and recent tests show that freight brake maintenance is very unsatisfactory, and the explanation does not lie in the fact that cylinders and

* Abstract of a paper presented and discussed at the April meeting of the Canadian Railway Club.

valves are stenciled without being cleaned. With a view of locating the real trouble four experts worked with the brake cleaners for a period of six weeks, making gage and soap suds tests of a large number of brakes, including those just cleaned and others that had run for various periods. With each brake found to have over five pounds brake cylinder leakage per minute from an initial pressure of 50 lb. the fault was located and remedied, and the local brake cleaner thereby shown how to remedy the defect. Among these defects may be mentioned in the order of their estimated proportions, defective brake cylinder packing leathers due to being worn, cracked, cut, porous, off center and applied reversed, loose brake cylinder piston follower nuts, dry and dirty brake cylinders, expanders out of place or not fitted, release valve or "bleeder" leakage, pressure cylinder head gasket leakage, cylinder pipe leakage with detached equipment.

The last mentioned is usually due to no provision for reasonable flexibility in the pipe and to the cylinder moving when the brake is applied and released. On roads handling much of such equipment, this cause for defective brakes will be relatively much more important. In addition to the ineffective brakes due to the foregoing causes, as disclosed by terminal brake tests, there are others, resulting from bad order brake rigging, such as broken rods, broken brake hangers and beams, good order brakes received cut out and left so without test, and brakes with a piston travel over 10 in. (Federal rules designate such as ineffective brakes.) As regards brake beams, a recent tabulation on a mountain division of one road showed an average for a week, based on conductors' reports, of two beams down per day, the principle causes being hanger pins out, or hangers broken.

The brake cleaning and repairing faults indicated above are merely symptoms and the real underlying cause for unsatisfactory freight brake maintenance is superficial inspecting, testing and repairing. The lack of sufficient time for this work, or possibly the lack of an adequate force of inspectors, results in obtaining a quantity of work at the expense of quality. There is often a daily local pressure to have certain bad order cars repaired at a certain time when the repair track is to be cleared, and the result of this pressure is a slighting of the work. Daily pressure, understandingly applied, is necessary, but the almost entire absence of a balancing pressure and provision for good work, together with the lack of sufficiently competent workmen and needed tools or materials will inevitably result in superficial repairing.

It has been shown that with good initial brake installation and efficient cleaning and lubricating, freight brakes will, as a rule, be reasonably efficient for from nine to 12 months. The results with many brakes apparently support this contention.

It is not only poor economy to allow insufficient time for brake repairs, but to try and use material that is worn out or otherwise defective. In one case under investigation, it was determined that excessive brake cylinder leakage was due to a badly worn and cracked packing leather. Upon questioning, the workman stated that he was aware of the condition of the leather, but had been reprimanded for using too many new leathers and thought he had "better take a chance on that one."

There is generally more reason to criticize undue retention of defective packing leathers, gaskets and rubber seats for emergency valves than of applying new unnecessarily. All such removed parts should be sent to a central point for inspection, so that any still suitable for use may be saved.

METHODS OF IMPROVING CONDITIONS

To improve conditions it is necessary first to secure more complete supervision of the work of repairing and maintaining freight brakes and in connection with that all employees must be educated to understand the importance and necessity

of efficient brake equipment. This is especially necessary because the very large labor turnover in railway repair shops has resulted in the employment of a force of men new to the work and seldom properly instructed as to how it should be performed. The second recommendation is the establishment of as many "dead line" points as possible where incoming freight trains may be inspected and the bad order cars set out for repairs.

Outgoing freight brake tests should be used merely to check against error, because if a bad order car is not detected until ready to go out, the result of switching it to the repair track at that late date is to disorganize the despatching and switching, and cause a serious delay to outgoing trains. The better plan is to make a freight brake inspection of each train immediately on arrival at a "dead point" while it is under blue signals. Assuming that the proper brake application was made by the incoming engine, a thorough brake inspection can be given, minor repairs made and cars with inoperative brakes marked for repair tracks, all during the time and protection afforded by the general inspection. As the air brake inspection must be begun as soon as the brakes are applied and must be completed quickly (within 20 minutes), it cannot be performed by men making the general inspection.

Under the proposed plan, the yardmaster is informed before switching just what cars are ready to proceed. Thus, brake delays to departing trains are avoided, brakes are maintained and incident expense is kept at the minimum.

But these desirable ends all depend on the correct performance of a simple duty by the incoming crew. The engineman must leave the brakes entirely applied by a 20-lb. reduction, merely adding to any reduction needed for stopping, the amount necessary to total 20 lb. It is possible to have this made as one reduction and some enginemen do so by carefully making the stop with the engine brakes only, but the first method will have to answer in many cases to avoid the delay of releasing and recharging.

If less than a 20 lb. reduction is made, some brakes in condition to proceed will be found unapplied. On being sent to the repair track these will be found operative and the inspector may be criticised for the unnecessary work and delay. Thereafter he will fear to mark brakes found unapplied "bad order," especially if there are several in a train. Thus, there will be either useless expense and delay, or brake maintenance will depreciate with its resultant dangers and ultimate greater expenses, all due to an improperly made incoming brake test.

In the repairing of car brake equipment it is understood that triple valves cannot be well maintained unless at each periodical cleaning they are cared for in a suitable room, having among its facilities a standard test rack. It is decidedly necessary that triple valves be not only cleaned, but repaired and put in good order. The manufacturer's instruction book for use of the standard test rack, gives much of the information needed to care for triple valve repairs fairly well, but the men who maintain the rest of the brake equipment on the car have generally to depend upon verbal instructions. To aid such men, the Westinghouse Air Brake Company has had certain of its men who are closely in touch with such work, prepare instructions for the brake work to be done on the car.

In general short piston travel (less than 6 in.) and brake pipe leakage render good braking very difficult. A piston travel of 9 in. is actually less objectionable than one of 6 in. The former by giving a much less increase for ordinary braking reductions, lessens slack action and consequent shock, yet is almost as efficient in full application as a 6-in. travel. It will be of interest to know that recent tests on a number of freight cars, starting from 50 to 60 lb. in the brake cylinder, gradually reducing the pressure, and noting the amount remaining after each $\frac{1}{4}$ -in. recession or loss in

piston travel, gave an average amount remaining of 30 lb. after $\frac{1}{4}$ -in. recession, 20 lb. after $\frac{1}{2}$ in., 10 lb. after $\frac{3}{4}$ in. and 5 lb. after 1 in. This test shows that 1-in. less in piston travel means a loss of all effective holding power.

The bad results from brake pipe leakage are much greater with long trains, and increase more rapidly than the train length; that is, a rate of leakage that would not be particularly detrimental with 40 cars, would prevent good handling with 80 cars. For the purpose of detecting brake pipe leaks, it is necessary to use the soap suds test. A loose pipe means a future leak, as also does a rigid pipe, where the need of some flexibility is plainly indicated. An example of this is given in the branch pipe connection from the main pipe to the triple valve.

One point that deserves attention is the waste of shoe metal and loss of brake efficiency resulting from brake shoes that overlap the wheel treads. This is due to the old head spacing of 60 $\frac{1}{2}$ in. magnified by manufacturing errors and the spreading action of the overlapping shoes. In addition to insuring that all new beams have the 60-in. spacing, the errors should be rectified in repairing old beams.

Trains cannot be held down steep grades with the air brakes without the aid of retaining valves and no part of the air brake requires less to maintain it, if once properly installed; also no part usually gets less attention. The lack of attention given this part of the equipment is well illustrated by the case of one railroad, which had entirely neglected to provide a piece work price for the testing and repairing of retaining valves. The cost of repairing and maintaining retaining valves in good condition is not large and such repairs should not be neglected on account of underestimating the value of the valve.

In regard to stenciling, the Northwest Air Brake Club of St. Paul, Minn., has proposed to the Air Brake Association a revision of M. C. B. requirements regarding brake repairing and stenciling, as follows: It is submitted that the present M. C. B. stenciling for freight brake cleaning, etc., can be simplified, time and money saved, brake maintenance improved, and more use obtained from the cars by adopting a rule that when either the triple valves or the brake cylinder must be cleaned, all other parts, including the retaining valve, dirt collector, etc., shall be cared for at the same time; also that any other repairs needed by the brake equipment shall be made. The stenciling should show the shop numerals, date and initials of the road doing the work. This information should be placed on both sides of the reservoir.

DISCUSSION

An interesting and somewhat extended discussion followed the reading of the foregoing paper. C. H. Weaver of the New York Central raised the question as to whether there was any inherent weakness in design or improper initial installation of the apparatus that could account for the many defects found in air brake equipment and foundation brake gear. It was the belief of the speaker, and many specific instances were quoted, to show that because equipment was going on a freight car, it was not considered important or necessary to do particularly careful work. The result was that many minor defects were allowed to go into the work and an improper initial installation was obtained.

It was stated in the paper of the evening that 37 per cent of derailments on a certain road were caused by brake beams dropping down which showed that too much attention could not be given to the method of applying brake beams, and the chairman stated that the Canadian Government Railways for six months had been following the practice of connecting brakes, so that the connecting rod will pass between the upper and the tension member of the bolster, the lower part of the truck lever being connected to the brake beam. In this way the brake hanger pin can drop out and the beam will not fall to the track.

The Canadian Government Railways started two "dead" points and were surprised to find the large number of brakes that would not pass the inspectors. A special effort is made to clean the brakes and get them in good condition during the summer months, because under the severe weather conditions during winter months, it is impossible to get the work done properly. Attention was called to the serious hose trouble due to cold weather and the fact that air brake men in Canada devote 50 per cent of their time in the winter to stopping leaks in the air hose gaskets. In one instance it required 1 $\frac{1}{2}$ hours on the Lake Superior division of the Canadian Pacific to get sufficient pliable hose and gaskets, so that the pump could maintain the maximum main line pressure. This trouble happened every time the train went into a siding between divisional points where the slack was bunched and stayed there over 15 minutes. When it started again and stretched out the slack in the train, the hose would leak in the gaskets.

L. H. Albers of the New York Central, stated that with proper maintenance on the road, less shop work would be required on freight cars and time would be saved in getting up train-line pressure in the yard, all of which will assist in getting trains over the road with a minimum delay. He also brought out the fact that there should be closer co-operation between the drafting room and the general air brake inspector and outside men. Very often cars are produced today with an entirely new design of brake gear, and the man in the field who looks after the brakes never even knows that these cars are coming until they arrive.

To show the importance of properly maintained brakes and the necessity of keeping all valves in good working order, P. J. Langan of the Delaware, Lackawanna & Western, cited two examples. A car on a heavy freight train on a descending grade was derailed by a broken wheel due to blocked retainers and wheel heating. A four-engine train was coming up the grade and the derailed car caught and overturned the tenders of the two engines on lead, the pressure of the two engines in the rear buckling the train in four places. All of this damage was the result of retaining valves being blocked.

Another case would have been serious had it not been for the good condition of the brakes on the train. A heavy train descending a grade had ice accumulate inside the brake pipe. This was loosened and blocked the angle cock on the first car back of the engine. The engineer immediately called for assistance. At the time there was 75 lb. pressure on the air gauge in the caboose and the conductor instead of using the conductor's valve in the caboose went out on the train to see what was the matter and did not think it necessary to open the valve. The train arrived at the bottom of the seven-mile grade without the least damage. The angle cock was freed from ice and the same train was taken down a grade twice as long without any work being done on the brakes, which showed that the brakes were in proper condition, whereas if they had been in bad shape there is no doubt but that a wreck would have happened that would have cost the Lackawanna \$100,000, and perhaps the loss of life. Proper brake maintenance is a necessity and when an engineer handles a train with the knowledge that his brakes are in good condition, it produces contentment in that man's mind for the remainder of the trip.

In connection with the incoming brake tests, W. Clegg, of the Canadian Northern, pointed out that when the brakes leak off, it is often difficult to determine whether the leakage takes place by the brake piston or the check valve in the triple valve, or whether it is due to brake pipe leakage.

In his final remarks, Mr. Farmer recommended that nine months instead of twelve should be the stipulated time for considering a brake out of order and some way must be found to make the repairs quickly and get the cars back into service as soon as possible.



SHOP PRACTICE



"THE REAL TEST IS TO GET RESULTS"

BY HARVEY DE WITT WOLCOMB

Suffering cats! but the "big boss" was mad. He was so hot that he could neither see straight nor think; and the busy terminal at Gardner suffered in consequence. Not that every roundhouse foreman is not out of sorts about something nearly all the time, for a roundhouse job is a continual grind on a man's nerves. But this day Dan Caddahan, the general foreman at Gardner, was uglier than usual. He was particularly polite, for one thing—a sure indication that he was loaded to the muzzle with a charge of sarcasm that would get any man's goat, and the men, knowing fully what to expect, kept their distance. It didn't take long for that mysterious shop method of spreading important news to warn every workman and sub-foreman to "watch out for the big boss."

And it was such an insignificant thing that caused all the trouble—just a piece of ordinary window glass. But then, it's generally the small things that start trouble on a railroad.

About three months ago—before the cold weather set in—Dan had checked up his winter requirements for cab sash glass, and had written the storekeeper a special letter asking that the supply he mentioned be secured at once so that when the time came they would have no cause for complaints. Unfortunately, the supply did not arrive, and about ten days prior to this eventful day Dan had a "run-in" with one of the engineers, who made a kick over putting in two pieces of glass in his cab window instead of one. At that time Dan personally asked the storekeeper to wire headquarters to make passenger train shipment, as they were then cutting up two larger glasses to fit the standard cab sash. This resulted in a waste of both glass and time to apply; also, it left a seam up and down the sash, through which water and wind could blow in on the engineer. The engineers began to kick, but Dan soothed their anger by promising early relief, just as soon as a supply of the right size glass arrived. This morning he had received a personal letter from the superintendent wanting to know why engineers' reports were not attended to, citing several cases of cab sash glass to be applied, yet the engineers reported no relief.

As Dan read this letter he went right up in the air and, started for the storekeeper's office, letter in hand.

Striding into the storekeeper's office, he angrily asked that worthy official to read the letter and then advise when he could expect a shipment of glass. The storekeeper hastily spoke up that he did not know what the present status was, but would secure the file. He was under the impression they had been "punching" the delivery of glass every other day.

"Oh, yes," replied Dan, "that is the usual case. You fellows don't seem to worry about getting material; you simply mark a letter 'punch every day or so,' and then that letter is handled with regular machine-like precision. What I want is glass, not 'punchers' or files. If you can't get any glass from headquarters, why don't you go uptown and buy some? Do anything to help out the situation, for both the

superintendent and I have troubles enough without any additional kicks from the engineers."

"That wouldn't do," said the storekeeper, "without first securing permission to make local purchase; and that would take at least two or three days to secure."

"Well, then, I suppose it is up to me to tie up a first-class locomotive," angrily replied Dan, "just because you are afraid to take a step to keep the road running. What are you here for, anyway! To follow orders and tie up power, or to use a little common sense and break a rule? Now, what shall I do?"

"Can't you find some other way out?" asked the storekeeper.

"That's it," answered Dan, "just another glaring example of why it is costing us so much to keep the old road going. Sure, I can build new sash for every locomotive, which will cost about fifteen times as much as glass will cost, and then as soon as I get the new sash made you will run out of the present size glass and I will have to alter the sash to suit. That is the way I am working all the time; rebuilding or making over just to suit the stock you happen to have."

"I am very sorry indeed," replied the storekeeper, "but my hands are tied and I cannot do any more than I am doing."

"Is that so?" said Dan. "Let me show you how a roundhouse foreman handles a situation like that. Why, man alive, if one of my foremen didn't have more backbone than any three men like you, I'd fire him on the spot. What you ought to do is to get the glass, for you know we need it. You are in a rut, and I am going to show you how to get supplies."

Turning on his heel, Dan left the office and went over to the dispatcher's office, for he wanted to send some telegrams. The first one he sent to the purchasing agent as follows: "Power tied up for glass, size twenty-six by thirty inches." Writing out another message, he told the operator to send the second one right after dinner. The second message read, "Glass not received. Am making local purchase to relieve situation. Rush regular supply passenger train." To both these messages, Dan signed the storekeeper's name, for he knew he was in deep water anyway, and if there was any trouble about his actions he might as well get fired for a big offense as for a small one.

Leaving the dispatcher's office, he sent one of the call boys up town to a hardware store for six glass of the size he needed, telling the boy to have the hardware company send him the bill. As other things demanded his attention, Dan dismissed this matter with a grin, as he thought of what would happen when the fireworks went off.

Long before noon Dan saw his carpenter going through the house with a big pane of glass under his arm, so he knew that temporary relief had been secured, anyway.

About four o'clock in the afternoon the storekeeper came down through the house with a telegram in his hand. Looking for Dan, he found that worthy official in an ash pan, and had to wait a few minutes before he could get near enough to show him the message.

"Do you know," said the storekeeper, "I have secured word from the purchasing agent that glass will be here on the night express, but I don't quite understand what he means in the last part of his message, where he says, 'O. K. to purchase.'"

Grinning all over, Dan turned to the storekeeper and said, "Let me tell you something. The real test of a successful roundhouse foreman is to get results. That same test applies to a storekeeper as well, only in your case it is to get material. This morning, when you couldn't get me any glass I helped myself, so just pin that message to this little bill and put it through in the regular manner."

INJECTOR GAGE

BY E. F. GLASS

In repairing the Simplex and the Sellers injectors, it has been found that the repeated facing of the steam nozzle seat allows the nozzle to enter too far into the combining tube, thus reducing the area around the nozzle and diminishing the efficiency of the injector. In order to overcome this

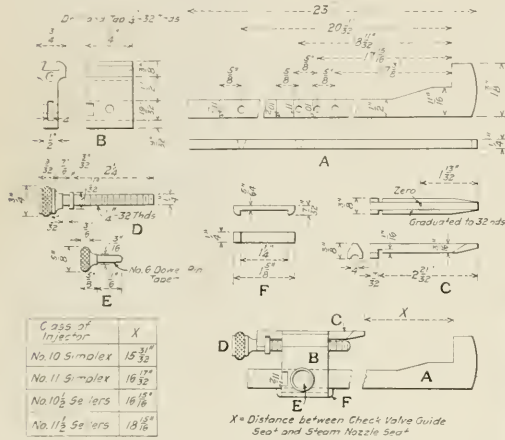

Gage for Maintaining the Correct Relation Between Injector Steam Nozzle and Combining Tube

defect, the idea was conceived to insert a brass collar between the steam nozzle and seat, the collar being bored out large enough to slip over the thread on the steam nozzle. The outside diameter of the collar is 1/4 in. larger and the thickness usually varies from 1/32 in. to 1/8 in. The gage illustrated was designed to determine the thickness of liner required.

Referring to the illustration, the gage consists of an adjustable jaw A, bracket B, slider C, adjusting screw D, dowel pins E and filling piece F. The distance X between the jaw and the slider is constant for each class of injectors and by moving the bracket B so that the dowel pins will fit in the four tapered holes indicated, it is possible to use the gage with the four different types and sizes of injectors shown in the inserted table.

The position of the taper pin is adjusted so that with the slider in a central position the distance X becomes standard in each case. The slider is marked to show the central position and graduations to 1/32 in. will readily indicate the amount of movement.

After the lever, steam bonnet, steam nozzle, combining nozzle, delivery nozzle and all other removable parts have been taken out the gage is inserted in the body of the

injector, the jaw end being held tight against the check valve guide seat near the delivery end of the injector, while the adjusting screw is turned until the point of the slider bears against the steam nozzle seat, which has been faced. The distance between the zero mark on the gage and the one on the slider will determine the proper thickness of the liner required.

This gage is inexpensive to make and its use keeps the distance between the check valve guide seat and the steam nozzle seat constant and at the required distance to insure uniform and efficient injector operation.

A TRAVELING ANTI-WASTE EXHIBIT

In a large manufacturing plant where thousands are employed, it is surprising to learn of the food products and manufacturing material wasted each day.

To give the employees of the Westinghouse Electric & Manufacturing Company some idea of the waste, the management devised the novel scheme of fitting up a storage battery truck as a traveling exhibit, upon it a collection of food wasted including bread, butter, meat, cakes, crackers, pickles, cheese, fruits, etc., as well as a quantity of manufacturing materials such as copper, zinc, lead, mica, rubber, felt, gum and similar materials much of which could be used to advantage.

It is estimated that the food stuffs wasted per day would amount to between \$35 and \$50, the cost of which, of course, comes out of the employees' pockets; the waste of material amounting to hundreds of dollars per day, which would be a loss to the company if it were not that a force of men are continually assorting the seemingly scrap material and turning it back for use or so that the highest price may be obtained for scrap produce, all due largely to the thoughtlessness and carelessness of the employees.

Above the material is constructed a sign, reading in large letters: "Wasted" and underneath the words "Food brought



A Waste Exhibit to Excite Thrift

from your homes." and on the other side "Materials belonging to the company."

This truck was driven up and down the shop aisles so that the employees could look upon it and form in their minds some idea of the waste. Such an object lesson is valuable at this time when everyone should take all the precautions necessary to cause anywhere as little waste as is absolutely possible.

Mcneer

Region

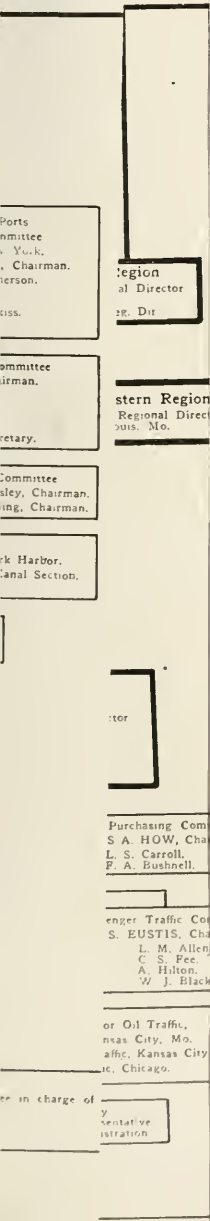

depending
 per the per
 piece work
 safety of our
 he capacity
 this can be
 the change
 another ad-
 those men

novelty re-
 also. Im-
 modest bank
 not secur-
 and many
 e workman
 the satis-
 character
 efforts were
 mated.

the service
 filled force
 oaters who
 rs' expense
 aterial and
 n than the
 e diminish-
 oration is
 th a wage
 ences over
 e for which
 ing prices
 s the piece
 assess great
 of knowing
 is paid to

PM

ing placed
 rt of bull-
 t perfectly
 mpt to ex-
 ich allows
 rbing the
 performed
 impossible
 rs in large
 stones at
 rthermore,
 output per
 e question,

lated and
 output, a
 influence),
 it cost and
 nance and
 dice work.
 he pension
 rol of the

PIECE WORK SYSTEM IN RAILWAY SHOPS

A Discussion of the Organization of the Methods for Determining Proper Prices and of the Forms Used

BY W. J. McCLENNAN

General Piece Work Inspector, Car Department, New York Central, West Albany, N. Y.

THE principal object of this paper is to contribute in some small measure to the solution of those problems confronting production supervisors or piecework inspectors of railroad repair shops in these strenuous days when patriotism and necessity impel them to achieve maximum results. It is hoped that these remarks may draw out that discussion which, like a postscript, is generally the most valuable part of any communication. Railroads everywhere are beginning to select successful piecework inspectors or production men for the jobs higher up, and if this paper incites an occasional inspector to increased effort that he may prepare himself the sooner for advancement, the writing will not have been in vain.

CHANGE FROM DAY WORK TO PIECE WORK

It is especially important at this time that every shop should embrace the fairest and most efficient system of remunerating their employees for services performed. Under piecework the highest wage is paid, but a maximum output is demanded in return. In spite of the fact that there is probably no other industry extant where it is so difficult to inaugurate the piecework system as in the modern railroad shop, with its thirty or more trades and its multiplicity of problems presented by the varying damage to the many classes of equipment, the writer contends that the piecework system is unquestionably the most practical and holds that under proper management it can be substituted for the per diem system. To some, the latter statement will sound presumptuous and they can quote instances where certain working forces objected strenuously and even instigated strikes when the change was inaugurated; but, after investigation of such instances, the methods followed by those in charge were in most cases found to be questionable; bankruptcy prices had been erroneously granted to the men and then reduced, the change to a piecework system was tried on a wholesale basis, which meant that those who through stubbornness or other motives were unwilling to give it a trial were pressed into the experiment for the purpose of making a showing initially, instead of confining the plan at first to the isolated minority who are always willing to better themselves and who know on which side their bread is buttered. The splendid patriotism manifested by the working classes since war was declared should indicate to anyone that they will accept piecework now if it will help their country to win the war.

Records will show that the majority of mechanical forces in railroad shops today are working on a piecework basis which, in itself, is sufficient evidence that others can do it. It is also a fact that 99 per cent of all piecework employees complain bitterly if they are asked to perform a job on day-work basis. Very few cases will be found where employees of "open" or union shops will object to any system which allows them to increase their earning power from 25 to 75 per cent, if a fair minded management points out that it can be accomplished by performing their work more scientifically.

OUTPUT AND WAGE INCREASES ACCOMPLISHED BY ADOPTION OF PIECEWORK

The adoption of the piecework system will decrease operating costs or increase the unit output from 50 to 100 per cent

without increasing the capital tied up in the plant, depending always on the degree of efficiency existing under the per diem system and the skill of those who install the piece work system. During the present man shortage the safety of our nation demands that steps be taken to increase the capacity of 100 men to 130, 140 and even 200. That this can be obtained is well known to those who have made the change from the per diem to the piece work system. Another advantage will be the increased wages accruing to those men who augment their output.

Such wage increases are stimulating while the novelty remains, and higher wages have their lasting effects also. Improved home life, constantly growing through modest bank account, with its attendant sense of satisfaction if not security, more extensive schooling for the children; these and many other advantages tend to raise the morale of the workman whose compensation is increased. The effect of the satisfaction to the men and the upbuilding of their character arising from the fact that their own increased efforts were responsible for these benefits can not be over-estimated.

For the corporation, there is an increase in the service rendered per man employed and a satisfied skilled force operating the plant instead of inexperienced floaters who improve their usefulness, if at all, at the employers' expense and make mistakes which cause waste of time, material and tools. No class of people live on a closer margin than the daily wage earner and they are quick to discern the diminishing purchasing power of the dollar. That corporation is not only fair but wise, which meets its men with a wage bonus during those periods when, through influences over which the operator has no control, the wage increase for which he has bent his utmost effort is offset by rapidly rising prices for the necessities of life. Under such conditions the piece work system of compensation will be found to possess great flexibility and the corporation has the satisfaction of knowing that any bonus allowed on piece work schedules is paid to a class of men who are producing maximum results.

OTHER ADVANTAGES OF PIECE WORK SYSTEM

The per diem system allows of no time limit being placed on output, in fact such efforts would be little short of bulldozing. The men are paid by the day and is it not perfectly human that they should be suspicious of any attempt to expedite output under a system of compensation which allows no reward for increased effort? The task of curbing the practice of spending excessive time on operations performed under the day work system is a distasteful if not an impossible one, and knowing the problems confronting workers in large railroad shops, it is far from the writer to throw stones at men who refuse to give something for nothing. Furthermore, under the day work system, a comparison of the output per man is impossible, and a cost system is out of the question, especially in assembly shops.

On the other hand piece work, properly regulated and inspected, insures good workmanship, maximum output, a wage scale based upon merit (not seniority or influence), minimum unit costs, standard practice and a perfect cost and estimating system. Freight and passenger maintenance and appraisal schedules would be impossible without piece work. It reduces the number of employees and therefore the pension and claim department costs. It places the control of the

wage earning power of the workmen right where it belongs, at the shop where the work is done. Of more importance than all these are the psychological advantages of the piece work system. It will automatically increase the satisfaction and hopefulness and therefore the health of the men, for an efficient piece work system anticipates diminishing the hours and even the fatigue of work.

PIECE WORK ORGANIZATION

The usual organization consists of one or more auditors or piece work inspectors in each department where the work justifies. These men report to their foremen and indirectly to a general piece work inspector, whose value to the company depends upon his executive ability, general knowledge and experience. Judging from observations made by the writer during a tour of practically every large railroad shop of the United States and Canada, the results obtained with this organization are satisfactory, considering the nature of the business.

SELECTION OF PIECE WORK INSPECTORS

A piece work inspector or production supervisor is selected not because he has worked at the given trade or one branch of it for a number of years, but, in spite of previous training, from that class of young men who possess the knack of distinguishing between action and progress, between load and capacity, between strenuousness and efficiency. If this qualification is supplemented by some practical shop experience I would almost say such a man is indispensable.

It is an error to select a man merely because he has spent years at the trade in question, sometimes at the expense of proper mental development and technical training, and very often to the neglect of that experience and association which would develop leadership, had he the potentiality. Irrespective of whether his knowledge were gained from books, schools, observation or factory experience, the production supervisor must know, or have the brain capacity to quickly learn, the art of correcting inefficiency. For instance, the machine shop production man must be able to detect the operator who is running his machine at less than the possible speed, feed and cut.

The profession of production engineering is one which, in the opinion of the writer, should command the attention and co-operation of all railway managements to the end that courses in instruction be provided for those of their employees who possess possibilities along this line. The result would more than justify the means.

QUALIFICATIONS OF THE PIECE WORK INSPECTOR

A shop inspector is only a novice until he is capable of efficiently superintending the mechanical operations of his department to their proper, economical and expeditious completion, and until he is possessed of sufficient training and resourcefulness to collect and arrange the facts and formulate the laws relevant to such operations. It is needless to add that he should be intelligent, tactful, energetic, resourceful, honest, and unresponsive to the influences of the unscrupulous. The managements of a few roads have recently realized that his salary and title should be such as to differentiate him from the direct labor forces, and it follows that the prestige thus accorded him will tend to make the operatives accept his conclusions more quickly. Neither should the shop piece work inspector be compelled to perform all his duties without frequent aid from the general piece work inspector, especially in the establishment of prices representative of large classes of work.

PRICE FIXING—CO-OPERATION OF FOREMEN

It is not considered wise to deprive foremen of certain rights in connection with the establishment of piece work prices in his shop. As a general rule the foreman's experience and loyalty enable him to give advice of the most valu-

able kind and the successful inspector seeks it often. On the other hand the foreman knows that he cannot devote the time to the subject which is essential if accurate decisions are to be made. Furthermore he realizes that he has no right to set himself up as the supreme and final authority in his department. The shop superintendent has rights and so has his general piece work inspector to whom all prices are submitted by shop inspectors. As in everything else, the co-operation of all concerned will produce the best results.

DUTIES OF SHOP PIECE WORK INSPECTORS

Every workman realizes that the eight or nine hour working day permits his working to full capacity during that time. He also knows that a machine should be operated to full capacity if it would represent a good investment for his employers. It is the paramount duty of piece work inspectors to determine the full capacity of the workmen and machinery and to evolve a system of keeping them at full capacity, for he will find that most workmen complain bitterly when, through interruptions or inefficiency of the management, they are prevented from earning their maximum rate per day. The maximum capacity of workmen and machinery is determined by a detailed study of performances.

OPERATION STUDIES

It is this part of the inspector's work which demands the active assistance and moral support of the general piece work inspector, as it is sometimes found that in setting prices influences from several quarters are exerted against the inspector. The operation study made by a competent inspector not only will show the possibilities of securing greater efforts from the workman, but should include a frank criticism of former methods, machine speeds, machine and hand tools used, material delivery, routing of work, etc. *It should also contain an outline of the best conditions and most approved methods he is able to determine for the performance of the job in future.* It is not always possible to do this without incurring the displeasure of the workmen and foremen, no matter how tactful the inspector may be, but the reward of perseverance, honesty and tactfulness in this regard is a saving in time, economy in operations and expedition of the work.

In timing a given operation, consideration should be given to the following factors, which are listed in the order of their importance:

- 1.—*Safety features, cleanliness, lighting effects.*
- 2.—*Availability of material.* Insure uninterrupted deliveries.
- 3.—*Condition of material.* For example:—If metal is being machined, be certain that it has not been subjected to precipitous cooling in the forging shop, or machining time and tools will be wasted.
- 4.—*Machine, tool or jig.*—Select proper type. Drilling holes 2 in. in diameter on a drill press designed for 1½-in. work is ridiculous and costly. Follow the latest approved data on machine speeds and feeds, angle of cutting tools and edges, heating treatment of tools, etc. If forging machine or bulldozer and furnace are involved, ascertain the time taken in heating and forging the article, also determine the forced inaction of the workmen between heats. If the furnace is loaded to full capacity and the record shows that unavoidable inaction of the men between heats is excessive, the need of a larger furnace is indicated.

5.—*Location of machinery.* This should be such that the work will pass through the machine shop without reverse movements or back travel.

6.—*Number of men used.* This depends entirely upon the circumstances. If the need for expeditious output is urgent, the working force must be larger (and the piece work price often greater) than would be necessary if the need for urgent deliveries did not exist. The statement that under ordinary conditions the men employed when studying an oper-

tion and performing the work thereafter should be the minimum number necessary to safely do the work, requires no elucidation.

7.—*Capacity of a workman.* A knowledge of this phase of the operation study can only be attained by diligent study. On all machine work the capacity of the workman is predetermined by the rating of the machine. These ratings, together with the correlated data obtainable as a result of exhaustive tests and calculations, enable an efficient piece work inspector to correctly establish the maximum amount of work which his men should produce when operating various machines. Some of this data, it is hoped, will be published later with the thought that it may encourage the beginners among railway shop inspectors to make further investigation of maximum machine output at minimum cost.

The capacity of an operator on bench work or material handling and assembling requiring manual labor exclusively, is quite another subject, and no set of rules can be promulgated for the guidance of the piece work inspector. Suffice it to say that he should see that constrained positions are always avoided. Lively movement may be demanded on light bench work, material deliveries and ordinary assembling or where cranes perform all the heavy work, but avoided on all heavy manual work.

In all cases of doubt the inspector should study the movements repeatedly until any unconscious or wilful slacking is brought to light. He should be able to settle upon a reasonable allowance for pauses and intervals of rest. (Appendix No. 1 illustrates the detail of timing records recommended by the writer.)

A determination of the capacity of the operator is the stumbling block of most inspectors, as some workmen, deliberately or through clumsiness, consume more time than is necessary on the operation. The inspector must ascertain, not the time consumed, but what should be consumed. There are many ways of determining the minimum time when an unfair operator is blocking your efforts. Often the job can be done by the inspector or gang foreman, by far the best method but often impossible on account of pressure of other work. It can be performed in other shops of the company and comparisons drawn. The time can be calculated by the "key" system explained hereafter. Or the job as performed by any operator can be so detailed as to show at a glance where the excessive consumption of time existed, as an experienced time study man soon learns the knack of properly judging the correct speed. The test can be made simultaneously by various men in the same shop thus trusting to the sense of competition which will be found among all men.

Only the most efficient operators should be timed and then only when exerting their best efforts. It is easy to make the proper allowances for the average men and set rates accordingly. When possible the work should be routed so that one gang's output and wages depend on the prompt and efficient action of the preceding gang.

If the inspector is honorable he will find that practically all of the men will meet him on the same basis. Exceptional ability and service should be rewarded by exceptional compensation. Allowance should be made for necessary interruptions in the work, and if the inspector timing an operation has not the creative instinct to recognize the need for and the ability to design suitable jigs to expedite the work before the piece work price is scheduled, he should not attempt to reduce a price on work for which a workman has devised a jig in order that he may increase his earnings. An inspector should be considerate enough to admit that no price should be based on the assumption that a workman should remain in a standing position all day if the work can be done while seated.

8.—*Rate used in setting prices.*—This angle of the operation study is simple and entirely in the hands of the local management. As stated above, when a piece work price is

based on the operation study of a workman possessing exceptional ability and performing at exceptional speed, the rate allowed should be exceptionally high. Proper consideration should be given to the frequency of the demands for the work in question and the number required.

9.—*Collection and arrangement of facts.*—During the operation study the efficient inspector will determine the best method of doing the work and direct the operator accordingly. With the determination of the proper time the piece work price is obtained by multiplying this time by a rate commensurate with the nature of the work and the ability of the workman. This should be graduated, if necessary, to allow a higher unit cost when one article is made at a time than would be allowed if 25 or more are made.

THE KEY PAYMENT SYSTEM

Prices for standard and recurring work in fabricating shops are of course based on the piece, pound, foot, cubic inch, etc., and the economy resulting from the price schedules is predicated on the character and efficiency of the machines on which the work is done, admitting the ability of the inspector and the operator. Such prices are handled similarly on all roads and need no attention in this article.

There are many difficulties, however, in working unusual and non-recurring jobs on the piece work basis and the writer has found that they can be overcome by the use of a "key" or scale prices. The use of this key obviates the necessity of compelling workmen to do such jobs at his hourly day work rate and at the same time avoids choking the price schedules with operations which may never be performed again. On a band saw, for example, a key price of \$0.08 could be paid for each miscellaneous piece not otherwise specified in the schedule, and a scale of prices ranging somewhat as follows could be allowed:

Saw, cut-off, No. 25, cut off all lumber with cross sectional area of 27 sq. in. or more, per cut made as recorded in indicator.....	\$0.07
Boards, not otherwise specified any length, cut to length fitted and nailed in position, ripping excluded, each.....	.01
Dove-tailing, including laying out and fitting, by hand, per pin and tail.....	.08
Dressing and sanding new sash-lary or oak, per square foot.....	.028
Gaining all classes of lumber by hand, per cubic inch.....	.025
Joint, cut by hand, per square inch of joint cut.....	.033
Molding, all classes, renewed, including dressing, per linear foot, per inch in width.....	.03
Patches, made and applied, including gaining, fitting and gluing, per patch under 50 sq. in.....	.025
Bolts, nuts, screws, holes, plugs, sawing, etc., in addition.....	

In this way almost any operation can be priced out, without timing unusual jobs and burdening the schedule with a specific reference to them. All unusual work required to be done on machines or by hand in blacksmith and machine shops is compensated in much the same manner. Miscellaneous prices are set up for heating iron and steel of limited sectional areas and the heating prices include necessary bending, plugging or cutting while hot. Higher prices are allowed for heats necessary to perform welds. Scrap axles and other material are drawn out to required size at \$4.00 to \$.50 per cut.

Key prices should be established on planers, shapers and slotters for removing a cubic inch of material, also setting up and removing work of given weights.

The same key price system is used with great success in all our big assembling shops. For example certain motors and wiring is installed in various shops, involving excavation, overhead and ground conduit and wire installations. Regardless of various locations, machine types, conditions, etc., attending each job, the entire operation is paid on basis of cubic yards of excavation, footage of conduit and wires, connections, outlets, switches, etc.

The same principle is applied whether the job in hand is running air or steam lines, building a private car or locomotive cab.

MISCELLANEOUS

All wood-working machines except band saws and a few others should be provided with meters or counters for com-

puting the amount of work performed daily. They act as positive checks on the output when properly applied and save considerable supervision. The method of installing them to prevent manipulation is interesting.

Price descriptions in fabricating shops embody the name of the machine, shop identification number, operation, machine speed and unit, as for example:

Sticker, Berlin, No. 89, operating speed 84 f. p. m., running through all material not otherwise specified, per 1,000 lineal feet, \$10.

All piece work prices on repairs should contemplate a higher payment for replacing reclaimed material than would be allowed for applying new parts. There is no better way of securing material economy than paying workmen this extra amount as they have more control over it than the foremen or others.

Every step should be taken to have replacement parts for freight cars on hand before the defective parts in kind are removed from the car. This would often save one or two days on release of much needed equipment.

All shop cleaning in wood mills is paid on basis of total lumber footage delivered into shops semi-monthly. It averages about \$.39 per 1,000 f. b. m. Shop cleaning and deliver-

tion of the time required to perform work on lathes and boring mills. The time setting up and removing operation varies of course according to nature of the article, and it will be readily seen that a 1/15-in. feed used with cutting speed of 20 f. p. m. consumes the same time as 1/30-in. feed with speed of 40 f. p. m.

APPENDIX No. 2

This appendix is submitted for guidance of those inspectors who are constantly confronted with the question as to whether workmen are using proper cutting speed and feeds while they are being timed for purpose of establishing new prices. It is not submitted as a panacea for all troubles, but will be helpful.

The following is a method of determining possible speeds and feeds for turning, boring, shaping, planing and slotting operations on motor driven machines using standard cutting tools at an angle of 75 deg. to 80 deg., such that selection, control and application of the motor to machines permit, as they should, using the peak motor load:

Regardless of the cutting speed, feed and cut, it has been found that under average conditions the horsepower required to remove one cubic inch of metal per minute is as follows. (Note—Special metals and cutting tools may cause considerable variation from these constants.)

A.—Mild steel (30 per cent to 40 per cent carbon).....	.6
B.—Hard steel (50 per cent carbon).....	1.25
C.—Hard fire steel.....	1.5
D.—Wrought iron.....	.6
E.—Cast iron, soft, hard.....	3 to 5
F.—Brass and similar metals.....	2 to 3

TABLE I

TIME IN MINUTES REQUIRED ON TURNING LATHES OR BORING MILLS FOR ANY WORK 1 IN. IN DIAMETER AND 100 IN. LONG

Note—For work of any dimensions multiply the diameter and length by the minutes shown at proper intersection, and then by the constant .01. Result is correct time in minutes. Example: Time required to turn a shaft 3 in. dia. 25 in. long, at cutting speed of 30 f.p.m. and $\frac{1}{16}$ in. feed. $3 \times 25 \times 7 \times .01 = 5.25$ minutes.

TOOL FEED IN INCH FRACTIONS

Cutting speed— F. P. M.	TOOL FEED IN INCH FRACTIONS																	
	1/40	1/30	1/25	1/15	1/12	1/10	1/9	$\frac{1}{8}$	1/7	$\frac{1}{6}$	$\frac{1}{5}$	$\frac{1}{4}$	$\frac{1}{3}$	$\frac{1}{2}$	$\frac{3}{4}$	1 in.		
10	104	80	66	40	32	26	24	21	18.5	16	13.5	10.5	8	5.5	4.2	3.5	3	2.6
11	94	72	60	36	28	24	22	19	17	14.5	12	9.5	7	4.8	3.8	3.2	2.8	2.4
12	88	66	56	33	26	22	20	17.5	15.5	13	11	8.9	6.5	4.5	3.5	2.9	2.7	2.2
13	80	60	52	31	25	20.5	18	16	14	12	10	8	6.3	4.1	3.3	2.8	2.5	2
14	74	56	47	28	23	19	17	15	13	11.5	9.5	7.5	5.9	3.9	3	2.6	2.2	1.9
15	70	52	44	27	21.5	18	16	14	12.5	10.5	8.8	7	5.4	3.7	2.9	2.5	2	1.8
16	66	50	41	25	20	17	15	13.5	11.5	10	8.2	6.8	5	3.4	2.8	2.3	1.9	1.7
17	62	46	39	24	19	16	14	12.5	11	9.5	7.8	6.3	4.8	3.1	2.6	2.1	1.8	1.6
18	58	44	37	23	18	15	13.5	11.5	10	8.8	7.4	5.9	4.5	2.9	2.3	1.9	1.7	1.5
19	56	41	35	22	17	14	12.5	11	9.5	8.4	7	5.8	4.2	2.8	2.3	1.8	1.65	1.4
20	52	39	33	20	16	13.5	12	10.5	9	7.9	6.8	5.25	4	2.6	2.1	1.75	1.6	1.3
22	48	36	30	18	14.5	12	11	9.5	8.5	7.4	6	4.8	3.8	2.5	1.9	1.7	1.5	1.2
25	42	32	27	16	13	10.5	10	8.5	7.5	6.4	5.4	4.5	3.4	2.1	1.8	1.6	1.4	1.1
27	39	29	25	15	12	10	9	7.5	6.5	5.8	4.9	3.9	3	1.9	1.7	1.5	1.3	0.9
30	35	26	22	13	10.5	9	8	7	6	5.4	4.5	3.5	2.8	1.8	1.6	1.4	1	0.8
32	33	25	21	12.5	10	8.5	7.5	6.5	5.8	4.9	4	3.3	2.6	1.7	1.5	1.2	0.9	0.7
35	30	23	19	11	9	7.6	7	6	5.3	4.5	3.8	3	2.4	1.6	1.4	1	0.8	...
37	28	21	18	10.5	8.5	7	6.3	5.7	5	4.2	3.5	2.8	2.2	1.5	1.3	0.9	0.7	...
40	26	20	16.5	10	8	6.8	6	5.3	4.5	3.9	3.3	2.65	2	1.45	1.2	0.8	0.7	...
42	25	19	15.5	9.5	7.5	6.3	5.8	5	4.3	3.7	3.1	2.55	1.9	1.4	1	0.7
44	23	17	15	8.9	7	5.9	5.3	4.7	4	3.5	2.9	2.45	1.8	1.35	0.9
47	22	16.5	14	8.5	6.8	5.6	5	4.5	3.9	3.3	2.8	2.4	1.7	1.3	0.8
50	21	15.5	13	8	6.3	5.3	4.8	4.3	3.7	3.1	2.7	2.15	1.65	1.2	0.7
52	20	15	12.5	7.5	6	5	4.6	4	3.5	3	2.6	2	1.6	1	0.7
56	19	14	12	7	5.8	4.8	4.3	3.7	3.2	2.6	2.4	1.9	1.55	0.9
60	17	13	11	6.5	5.3	4.5	4	3.3	3	2.5	2.3	1.75	1.5	0.85
62	16.5	12.5	10.5	6.3	5	4.3	3.9	3.4	2.9	2.5	2.2	1.65	1.45	0.8
66	16	12	10	6	4.8	4	3.7	3.2	2.8	2.4	2	1.6	1.4	0.75
70	15	11	9.5	5.8	4.5	3.8	3.5	3	2.6	2.3	1.9	1.5	1.3	0.7
72	14.5	10.8	9	5.5	4.3	3.6	3.3	2.9	2.5	2.1	1.8	1.45	1.2	0.65
76	13.5	10.4	8.8	5.2	4.1	3.5	3.1	2.7	2.4	2.1	1.7	1.4	1.1	0.63
80	13	10	8.8	5	3.9	3.3	2.9	2.6	2.3	2	1.65	1.3	1	0.6
82	12.5	9.8	7.9	4.9	3.8	3.2	2.8	2.5	2.2	1.9	1.6	1.25	0.9	0.55
86	12	9.4	7.5	4.7	3.6	2.7	2.5	2.3	2.1	1.8	1.5	1.2	0.8	0.5
90	11.7	8.9	7.3	4.5	3.6	2.9	2.6	2.3	2	1.7	1.5	1.15	0.7	0.45
92	11.3	8.6	7	4.3	3.3	2.8	2.5	2.2	1.9	1.6	1.45	1.1	0.6	0.4
96	11	8.4	6.9	4.1	3.2	2.7	2.4	2.1	1.8	1.5	1.35	1.05	0.5	0.35
100	10.5	8	6.5	3.9	3.1	2.6	2.3	2	1.7	1.4	1.3	1	0.4	0.33

ing in all repair shops and yards is paid on a percentage system, based on the total piece work earnings of the repairmen, including earnings of day work operatives priced under the same schedules. This is probably the most successful system yet evolved for the handling of the laboring problem at large shops. The percentages vary from .05 to .30, according to conditions and work imposed. The matter should be handled under allowance system so that adjustments would only be necessary every third month.

Appendices
APPENDIX No. 1

The chart shown in Table I. is recommended to shop piece work inspectors or production supervisors for rapid compu-

G.—(Lathe)—Cutting speed in inches per minute equals diameter of work, in inches, multiplied by spindle r.p.m. and 3,1416.

G.—(Boring Mill)—Cutting speed in inches per minute equals diameter of work, in inches, multiplied by table r.p.m. and 3,1416.

G.—(Shaper, Planer or Slotter)—Cutting speed in inches per minute equals necessary tool travel in inches per minute.

H.—Area of cut in square inches equals depth of cut (in.) multiplied by tool feed (in. per rev. or stroke), on slotters with inward feeding cutting-tool area of cut, in square inches equals width of tool and cut multiplied by feed per stroke.

I.—Cubic inches of metal removed per minute equals G multiplied by H.

J.—Horsepower required to remove mild steel would then be A multiplied by I (or 6 multiplied by J).

NOTE: Power required to reverse planers is more than that necessary to cut metals. On a shaper it is ordinarily less.

K.—Cubic inches of mild steel possible to remove per minute is equal to the motor horsepower divided by 0.6.

The following is a method of determining possible speeds and feeds for drilling operations on motor driven presses using standard drills:

The motor horsepower requirements for removing one cubic inch of metal per minute are safely figured at double the constants indicated in A to F inclusive, because of the drill friction and choking caused by movement of chips in holes.

(4) Electrical tests (as a result of incomplete fusion, slag inclusions and porosity), showing variations in:

- (a) Electrical conductivity.
- (b) Magnetic induction.

The most complete use of these tests would involve their application to each layer of deposited metal as well as to the finished weld. Excepting in rare instances this, however, would not be required by commercial practice in which a prescribed welding process is followed.

Of the above methods the visual examination is of more value than is commonly admitted. In conjunction with it the chipping and calking tests are of particular usefulness. As, however, only a very poor joint will respond to the latter tests, they serve to indicate gross neglect by the operator of cardinal welding principles.

The penetration tests offer the most reliable indication of the soundness of a weld. Obviously, the presence of unfused oxide surfaces, slag deposits and blow holes will offer a varying degree of penetration. The use of X-rays gives excellent results in the test of small samples, but due to the nature of the apparatus, time required and difficulty of manipulating and interpreting results, it can hardly be considered at the present time applicable to large scale production.

The rate of leakage of hydrogen or air through a joint from pressure above atmospheric to atmospheric, or from atmospheric to partial vacuum can be readily determined. However, the equipment required would be quite cumbersome and the slight advantage over liquid penetration in time reduction is not of sufficient merit to warrant consideration for most welds.

Of the various liquids that may be applied, kerosene has marked advantages due to its availability, low volatility and high surface tension. Because of the latter characteristics, kerosene sprayed on a weld surface is rapidly drawn into any capillaries produced by incomplete fusion between deposited metal and weld scarf or between succeeding deposits, slag inclusions, gas pockets, etc., penetrating through the weld and showing the existence of an unsatisfactory structure by a stain on the emerging side. On dissolving suitable oil soluble dyes in the kerosene the penetrating liquid will produce a bright red stain. This test is so useful that it has shown the presence of faults that could not be detected with hydraulic pressure or other methods. A sequence of imperfect structures linked through the weld, which presents the greatest hazard in welded joints, will be immediately located by the kerosene penetration. However, it should be borne in mind that this method is not applicable to the detection of isolated slag or gas pockets, nor small disconnected unused areas. Nevertheless it has been shown by numerous tests that a weld may contain a considerable amount of distributed small imperfections without affecting appreciably its characteristics.

If the kerosene test betrays a bad fault it is advisable to burn out the metal with a carbon arc before a rewelding under proper supervision. Large quantities of kerosene are preferably removed by means of sand blast, steam, gasoline CCl_4 , etc. No difficulty, however, has been encountered on welding over a thin film of the liquid.

Electrical test methods for determining the homogeneity of welds are still in the evolutionary stage. Such obvious difficulties as elimination of the effect of contact differences, influence of neighboring paths and fields, the lack of practicable portable instruments of sufficient sensitivity for the detection of slight variations in conductivity or magnetic field intensity are yet to be overcome before their employment is feasible.

No simple tests are available, excepting those which involve subjecting the metal to excessive stresses, for determining the crystal structure. Control of this phase must be determined by the experience obtained from following a prescribed process.

While, therefore, the inspector of metallic arc electrode

welds may consider that through the proper use of visual, chipping and penetrating tests a more definite appraisal of the finished joint may be secured than is possible in either riveting or concrete construction, the operation may be still further safeguarded by requiring rigid adherence to a specified process.

GOOD RESULTS ARE CERTAIN IF PROPER PROCEDURE IS FOLLOWED

Haphazard welding can no more produce an acceptable product than hit-or-miss weaving will make a marketable cloth. It is logical that the steps in every manufacturing operation should be controlled to obtain consistently good results. Unfortunately, most welders consider themselves pioneers in an unknown art that requires the exercise of a peculiar temperament for its successful evolution. As a result, welding operators, too numerous to mention, enshroud themselves in the hallowed glow of an expert and encompass their work with a mysterious camouflage bewildering to the untutored. Sometimes, through a series of fortunate coincidences, these "experts" succeed in obtaining a good weld, but more often their "success" is attributable to the friction between slightly fused, plastered deposits.

The process of metallic electrode arc welding, in common with all other operations, is readily susceptible of analysis. Regardless of the metal welded with the arc, the cardinal steps are: (1)—Preparation of weld; (2)—Electrode selection; (3)—Arc current adjustment; (4)—Arc length maintenance; (5)—Filling sequence, and (6)—Heat treatment.

A complete discussion of all of the variations possible in these operations is beyond the scope of this article.*

The preparation of the weld involves sufficient scarfing and separation of the weld shanks so that the entire surface is accessible to the operator with a minimum amount of fill-

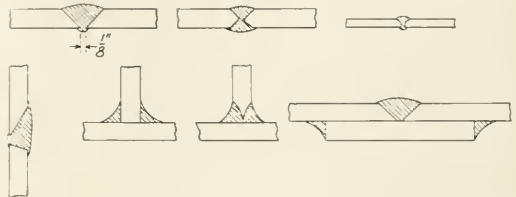

Fig. 1—Typical Arc Weld Scrap

ing required. In addition, where necessary to avoid distortion and internal stresses due to unequal expansion and contraction strains, the metal is preheated or placed so as to permit the necessary movement to occur. Various types of scarfs in common use are shown in Fig. 1.

The electrode selection is determined by the mass, thickness and constitution of the material to be welded. An electrode free from impurities and containing about 17 per cent carbon and 5 per cent manganese has been found generally satisfactory for welding low and high carbon, as well as alloy steels. This electrode may also be used for cast iron and malleable iron welding, although more dependable results, having a higher degree of consistency and permitting machining of the welded sections, can be obtained by brazing, using a copper-aluminum-iron alloy electrode with the aid of some simple flux. The brazing of copper and brass with this electrode also gives very successful results. The diameter of the electrode should be chosen with reference to the arc current used.

THE EFFECT OF TOO LOW CURRENT VALUES

It has been almost universal practice to attempt welding with too low an arc current and the result has been a poorly

*1917 Volume, Association of Iron & Steel Electrical Engineers. "Some Recent Investigations in Arc Welding," by O. H. Eschholz.

fused deposit. This is attributed largely to the overheating characteristic of most electrode holders, on using correct current value, leading the operator to infer that the current used is excessive.

A section through one-half of an exposed joint welded with the proper current is shown in Fig. 2, while Fig. 3 shows the effect of too low an arc current. The homogeneity and good fusion of the first may be contrasted with the porosity and poor fusion of the latter. (These surfaces have been etched to show the character of the metal and the welded zone.)



Fig. 2—Good Weld



Fig. 3—Poor Weld

Approximate values of arc current to be used for given thickness of mild steel plate as well as the electrode diameter for a given arc current may be taken from the curve, Fig. 4. The variation in strength of 1-inch square welded joints as the welding current is increased is shown in Fig. 5.

While the electrodes now available are giving quite satisfactory results, it is felt that the electrode development is in its infancy and that considerable strides will be made (with its further evolution) in the ductility of welds, consistency in results, as well as in the ease of utilizing the process.

The maintenance of a short arc length is imperative. A non-porous, compact, homogeneous, fused deposit on a 1-inch square bar from a short arc is shown in Fig. 6, while in

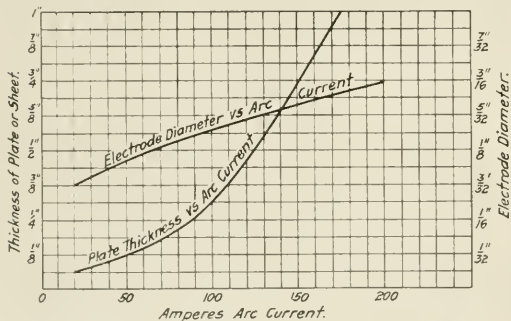

Fig. 4—Chart Showing Approximate Arc Current and Electrode Diameters for Welding Steel Plate of Various Thickness

Fig. 7 is shown a porous, diffused, unfused deposit from a long arc. A skillful operator normally maintains a short arc as the work is thereby expedited, less electrode material wasted and a better weld obtained, due to improved fusion, decreased slag content and porosity. On observing the arc current and arc voltage by meter deflection or from the trace of recording instruments the inspector has a continual record of the most important factors which affect weld strength, ductility, fusion, porosity, etc. It is possible by the use of a fixed series-resistance, and an automatic time lag reset switch across the arc to definitely fix both the arc current and the

arc voltage, thereby placing these important factors entirely beyond the control of the welder and under the direction of the more competent supervision.

HEAT TREATMENT AND INSPECTION

The method of placing the deposited layers has an important bearing on the internal strains and distortion ob-

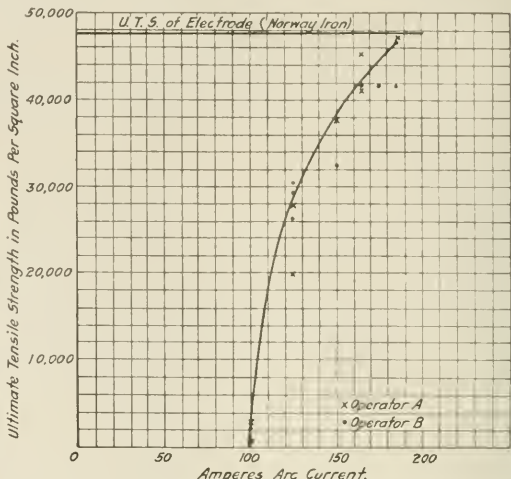

Fig. 5—Variation in Weld Strength With Change in Arc Current

tained on contraction. Part of these strains may be relieved by preheating and annealing, as well as by the allowance made in preparation for the movement of the metal.*

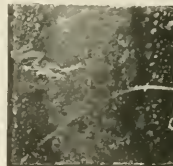
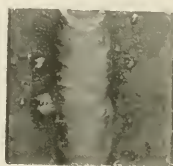

Fig. 6



Fig. 7

Top and Sectional Views of Metal Deposited from Low Carbon Steel Electrode on Steel Stock

In general, heat treatment of a completed weld is not necessary, particularly if it has been preheated for preparation and then subjected to partial annealing. However, in weld-

*Power, June 26, 1917. "Welds—The Weakness and Merits of Their Structure," by P. A. E. Armstrong.

ing even small sections of alloy and high carbon steels a uniform annealing of the structure is desirable if it is to be machined or subjected to vibratory stresses.*

In addition to applying the above tests to the completed joint and effectively supervising the process the inspector can readily assure himself of the competency of any operator by the submission of sample welds to ductility and tensile tests

or by simply observing the surface exposed on cutting through the fused zone grinding its face and etching with a solution of 1 part concentrated nitric acid in 10 parts water.

In view of the many resources at the disposal of the welding inspector, it is confidently assumed that this method of obtaining joints will rapidly attain merited recognition as a dependable operation in structural engineering.

HEAT TREATMENT OF AXLES

The Scientific Heat Treatment of Locomotive and Car Axles Made Possible by Use of Electric Furnace

BY DWIGHT D. MILLER

Engineering Department, Society for Electrical Development, Inc., New York

ONE of the most important metallurgical processes involved in the manufacture of locomotive and car axles is heat treatment, and heat treatment is best carried out and reduced to an exact science through the medium of the electric furnace. In order to appreciate the important part the electric furnace plays in the manufacture of axles, it is necessary to have at least a general knowledge of the composition of steel and the effect of heat treatment upon it.

STRUCTURE OF STEEL

While steel is essentially an alloy of iron and carbon and usually contains impurities in the form of sulphur, phosphorus, silicon and manganese, still its structure is complex and composed of distinct and individual grains which appear in different crystalline formation under the microscope. These various grains are known as cementite, ferrite and pearlite. They are formed during the process of heat treatment and impart varying physical characteristics to the steel. The extent of their formation depends upon the carbon content of the steel.

In the composition of ordinary carbon steel the impurities mentioned above will total about one per cent, while the carbon varies from a few hundredths of one per cent to approximately two per cent. The rest is iron.

EFFECT OF HEAT TREATMENT

If the steel is cooled slowly after being brought to a high heat the carbon always combines with a certain definite amount of iron forming a carbide of iron (Fe_3C) which is the compound cementite. The remaining iron is then carbon free and is known as ferrite. After the formation of cementite and while the cooling process is still going on, the cementite forms a mechanical mixture with a definite amount of ferrite producing a grain structure known as pearlite, which always contains approximately .89 per cent carbon. Hence carbon steel may be divided, according to the difference in the proportions in which the carbon is present as compared to the iron content, into (a) unsaturated (hypo-eutectoid) steel with a carbon content of less than .89 per cent and consisting of pearlite and an excess of ferrite; (b) saturated (eutectoid) steel with a carbon content of .89 per cent consisting wholly of pearlite; and (c) super-saturated (hyper-eutectoid) steel with a carbon content of more than .89 per cent consisting of pearlite plus cementite. This composition is clearly set forth in Sauveur's ferrite-pearlite-cementite diagram.

Hence, since the physical characteristics of slowly cooled steels depends upon the relative proportions of these constituents which vary among themselves in their physical properties, the vital importance of proper heat treatment becomes

at once apparent. In fact by applying varying degrees of heat the entire structure of a given steel can be partially or completely changed since it is well known that during the heat treatment of steel evolutions occur in the molecular structure at certain temperatures during both heating and cooling.

The temperatures at which molecular evolutions or changes occur are known as the "critical points." That temperature at which the changes takes place when heating the steel is technically known as the "decalescence" point, while the temperature at which a change takes place when cooling the steel is known as the "recalescence" point.

To quote from the "Heat Treatment of Steel" published by the Industrial Press: "While heating, the steel uniformly absorbs heat. Up to the decalcescence point all of the energy of this heat is exerted in raising the temperature of the piece. At this point the heat taken on by the steel is expended not on raising the temperature of the piece, but in work which produces the internal changes here taking place between the carbon and the iron. Hence, when the heat added is used in this manner, the temperature of the piece, having nothing to increase it, remains stationary, or owing to surface radiation, may even fall slightly. After the change is complete the added heat is again expended in raising the temperature of the piece, which increases proportionally.

"When the piece has been heated above the decalcescence point and allowed to cool slowly, the process is reversed. Heat is then radiated from the piece. Until the recalescence point is reached, the temperature falls uniformly. Here the internal relation of the carbon and iron is transformed to its original condition, the energy previously absorbed being converted into heat. This heat, set free in the steel, supplies, for the moment, the equivalent of that being radiated from the surface, and the temperature of the piece ceases falling and remains stationary. Should the heat resulting from the internal changes be greater than that of surface radiation, the resulting temperature of the piece will not only cease falling but will obviously rise slightly at this point. In either event the condition exists only momentarily, but when the carbon and iron constituents have resumed their original relation the internal heating ceases, and the temperature of the piece falls steadily, due to surface radiation." The temperature variations referred to are clearly shown in Fig. 1.

The general term "heat treatment" includes three distinct and separate operations. They are: (1) Hardening in which the steel attains its hardest and most brittle state; (2) Annealing, in which the steel attains its softest and toughest state; (3) Drawing or tempering, in which the steel attains an intermediate condition. These operations constitute the complete cycle of heat treatment.

Hardening consists of heating the steel uniformly above the

*Railway Mechanical Engineer, February, 1918. "Microscopic Study of Welded Joints," by S. W. Miller.

decalescence or critical point and then cooling it rapidly in some medium such as water, oil or brine. The temperature to which it is necessary to heat the steel above the critical point depends upon the carbon content. It is not advisable to heat much above the critical point since an increased temperature tends to enlarge or coarsen the grain, wastes fuel and has no appreciable effect on the hardening process.

The nature of the quenching medium however, does affect the results obtained. Greater hardness is obtained by quenching in salt brine than in water, while water quenching pro-

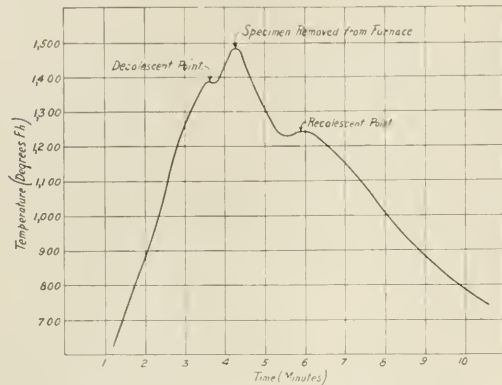

Fig. 1—Temperature Changes in a Piece of Steel Uniformly Heated and Allowed to Cool

duces greater hardness than oil quenching, the temperature in all cases remaining the same. Likewise the physical properties are materially affected by the rate at which the steel is cooled and the length of time it is immersed in the quenching bath.

In general the process of annealing consists of slow cooling from a high temperature at or above redness. The object of this treatment is to either: (1) Completely undo the effect of hardening, leaving the steel in its softest and most ductile condition; (2) Refine the grain to obtain the desired strength; or, (3) Remove any stresses and strains set up by too rapid cooling, especially if the rate of cooling is different in different parts of the piece, also those caused by forging and cold working. To accomplish (1) and (3) it is sufficient to heat below the critical point, but for grain refining (2) the temperature must be raised above the critical point. In practice, cooling during this process is effected by leaving the piece in the furnace at a reduced temperature or allowing it to cool in the air.

The process of tempering or drawing has for its object the partial removal or moderation of the effect of previous hardening. The operation consists of heating the piece to a somewhat lower temperature than for the purpose of hardening, not allowing it to reach the critical point, and then cooling it slowly in air. This treatment decreases the hardness and increases the toughness of the steel. The degree of these changes is governed by the temperature used for reheating, its uniform penetration into the metal and the length of time the metal is subjected to it.

From the foregoing it is apparent that the accurate control of temperature is of prime importance in all heat treatment. If the temperature is too low the results sought are not attained, while if the temperature is too high the steel is "burned" resulting in total loss.

The necessary heat treatment will depend on the quality of steel needed for locomotive and car axles and attention is called to the standard specifications of the American Society

for Testing Materials and the American Electric Railway Association.

STANDARD SPECIFICATIONS FOR AXLE STEEL

	A. S. T. M.	A. E. R. A.	Electroheat
Ultimate strength, lb. per sq. in.	85,000	85,000	95,000
Elastic limit, lb. per sq. in.	50,000	50,000	60,000
Elongation in 2 in., per cent.	20.5	22	20
Reduction of area, per cent.	39.	45	40

That these specifications can be met and are being materially bettered in some respects in daily commercial practice is shown by reference to column three in the above table. Under the heading of "Electroheat" are given results obtained by the Laclede Steel Company of St. Louis, Mo., which makes use of an electric furnace for heat treating car axles.

ELECTRIC FURNACE FOR HEAT TREATING

The electric furnace used is known as a resistance or reverberatory type in that the heat generated is reflected mainly from the roof onto the charge under treatment. On either side of the furnace running back through the entire depth, are the two resistor troughs, supported on brick piers which serve to conduct the heat generated in the trough material and diffuse it uniformly, thus avoiding hot spots in the refractory lining of the furnace in their immediate vicinity. The troughs are open at the top, being filled with resistor material consisting of finely broken carbon or graphite which becomes incandescent throughout the entire length of the trough at the passage of electricity.

The heat of these huge filaments is radiated to the roof and from there reflected back onto the hearth of the furnace and the material under treatment.

The furnace is charged by means of a car on wheels which runs on rails and is operated by suitable worm and spur gears actuated by an electric motor the entire mechanism being located underneath the flooring.

This construction provides an efficient and durable heat treating furnace. The losses due to heat radiation are small,



Fig. 2—Electric Furnace and Charging Car

and both the atmosphere and temperature can be controlled to a remarkable degree of accuracy.

The furnace has a capacity of 1,000 lb. per hour when heating to 1,650 deg. F. It is rated at 150 kw. and designed for 2 phase, 25 cycle operation. The voltage used will depend upon the resistance of the resistor material in the trough and is stepped down through transformers from 13,000 volts supplied from the central station. In this particular case the voltage used varied from 150 down to 70 volts according to the heat requirements of the operation.

The usual instruments such as wattmeters and switches necessary for the proper operation of the furnace are installed upon the switchboard, together with a pyrometer by means of which an accurate record of the furnace temperature is obtained at all times.

The operation of the furnace is simple. Upon closing the main switch, current at full rated voltage is sent through the resistor material in the trough which is a poor conductor of electricity, especially when cold. The resistance to the flow of current transforms the electrical energy entering the troughs into heat energy and the furnace begins to heat up. Due to the negative temperature coefficient of the carbon or graphite resistor material it becomes a better conductor the hotter it gets so that as its conductivity increases its resistance decreases and more current flows. This fact is duly indicated by the instruments on the board and when the power input tends to become excessive it is cut down and held con-

stant by lowering the voltage by means of an operating transformer provided for its control. The time it takes to bring the furnace up to desired temperature depends of course on whether the furnace is cold or already partially heated and upon the process to be performed.

(3) The uniformity of heating and absorption of heat by radiation tends to eliminate all internal strain due to uneven heating.

(4) Since electric energy in practically all cases is furnished by central stations with highly efficient power units there is a big saving in coal.

(5) The absence of noise, gas fumes and smoke and large heat radiation greatly improve the conditions of labor.

An electric furnace could be used in railroad repair shops with much benefit in overcoming the stresses and strains set up in the repaired metal parts.

SPRING STRIPPING MACHINE

BY J. M. MAC DONALD
Blacksmith Foreman, Maine Central, Portland, Maine



Fig. 3—Dipping the Axles in the Cooling Tank

stant by lowering the voltage by means of an operating transformer provided for its control. The time it takes to bring the furnace up to desired temperature depends of course on whether the furnace is cold or already partially heated and upon the process to be performed.

At the plant of the Laclede Steel Company the raw material for axles is received in the form of steel billets running around .35 to .50 per cent carbon. These billets are forged to the proper shape and size. After being allowed to cool in the air they are loaded in a cradle on the car of the electric heating furnace. It should be noted from Fig. 2 that each separate piece is so loaded that there is free air space completely around it. This is to enable the heat to reach all parts of each piece and penetrate uniformly. When properly loaded the car is run into the hot furnace and the axles allowed to soak for a certain definite time.

After heating at about 1,600 deg. F. the car is run out and the cradle with its load lifted off by an air hoist and immediately quenched in a water tank situated near the furnace and shown in Fig. 3. The charge, is then put back into the furnace and held there during a definite period at a drawing temperature of about 1,200 deg. F.

The advantages of the foregoing method of heat treating car and locomotive axles are largely due to the use of the electric furnace and may be summed up as follows:

(1) The accurate control of temperature, together with a clean heat provides a product of superior physical characteristics and grain structure—meaning longer life.

(2) Electric measuring instruments and the pyrometer make possible the exact duplication of conditions and prevent

loss of material due to improper treatment—meaning less rejections.

The spring stripping machine shown in the illustration has given particularly good service. It is about 7 ft. high and is comparatively simple in construction. The main framework is built of 3/4-in. by 4-in. by 6-in. angles suitably bolted together and braced with 1-in. by 3-in. iron. This framework fits in a concrete base on which rests a cast iron block cut out to suit the ends of the springs. There are two levers made of 1 1/2-in. by 7-in. stock, tapered at the end to about 4 in. as indicated. These levers are proportioned to give a ratio of 15 to 7, and the fulcrum bolt, which fits in holes in the angle iron, may be adjusted for different heights, depending upon the length of the spring.

Power to operate this machine is furnished by means of a 12-in. by 10-in. air cylinder, suitably bolted to the bottom of the framework. This cylinder is not plainly shown in

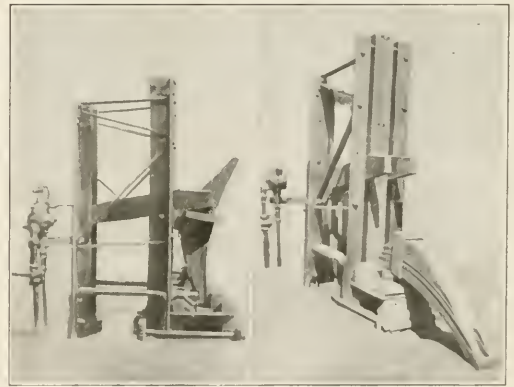

Spring Stripping Machine Used on the Maine Central

the illustration but operates on the left hand end of the levers to force them up. The supply of air is controlled by a G-6 brake valve. With an average pressure of 90 lb. per sq. in. in the cylinder, it is possible to obtain from 12 to 25 tons pressure on the spring band, depending on the position of the levers.

In operation, the spring which it is desired to strip is appended on the concrete base, as shown at the left, and the fulcrum bolt adjusted to the hole which is best suited to the length of the spring. A yoke which has been cut out just wide enough to slip on over the spring above the band is then put in place and the air pressure applied. In starting the band as short a leverage as possible should be used, thus giving a greater pressure on the band. As a rule, when the band has been started, the spring leaves loosen up so that it

is comparatively easy to finish taking off the band as shown at the right of the illustration.

After this machine was built it was found necessary to apply a rubber bumper at the top to relieve the shock when the band gives way. By having a set of yokes suited to the width of the different standard springs, it is possible to use this machine for any spring on the system with no adjustment except for the length.

THE LOSSES IN A SMALL POWER PLANT

BY A. G. D.

Sometime since I had occasion to make a rather complete test of the power situation in a steam railway car shop, located near Cincinnati and belonging to a well-known company. The result of the analysis brought to light several ways in which power is lost or dissipated that do not often appear. The power was supplied by a 14-in. by 30-in. Vilter Manufacturing Company Corliss Engine, which was belted to a main shaft, so located that the belt ran upwards at an angle of about 60 deg. from the horizontal. A 22.5-kw. generator was belted to the main shaft and this furnished electric lights and current for charging batteries.

The equipment in the shop was briefly as follows: The machine and blacksmith shop contained grinders, emery wheels, lathes, planer, drill press, forges, and other similar machine tools—in all totaling eighteen. The polishing room contained two buffers and a drill, three tools in all. The laundry contained a washer, wringer, hair and feather picker—four machines. The carpenter shop contained a blower, saws, stitcher, woodworker, planer, lathes, etc.—fourteen machines in all.

The Corliss engine was called upon, therefore, to operate the electric generator and thirty-nine machines.

An all day test was made on the plant, weighing the coal, taking indicator cards every ten minutes to get the average load, and cards at noon to get the power in overcoming the engine, generator belt and shafting friction and losses.

The average distribution of the total indicated horse power was as follows:

Engine friction and loss.....	7 h.p.	11.5 per cent
Generator losses.....	3 h.p.	4.9 per cent
Shafting and belt losses.....	19.7 h.p.	32.3 per cent
Generator output (in horse power).....	25 h.p.	41.0 per cent
Lower to operate 38 tools all shaft and belt driven.....	6.3 h.p.	10.3 per cent

Total..... 61 h.p. 100 per cent

The loss of 32 per cent in belt and shaft friction is somewhat above the average encountered in the ordinary plant and should be cut down, while an average of 48.7 per cent of the energy developed in the engine cylinder, being absolutely lost is worthy of attention.

The engine itself operates about as well as any I have ever seen. The speed was taken at regular intervals throughout the day and it ran from 100 to 102 revolutions per minute—i. e., with better than two per cent regulation.

Regular readings of the voltage of the generator were taken as part of the data. The normal voltage was 117. Now with a direct current generator with a constant field excitation, the voltage from the generator is a direct measure of speed. The voltage varied from 117 to 108 with an average throughout the day of 113½, or 3 per cent below normal. This showed that the generator was running 3 per cent slower than normal, and so consequently was every machine in the shop. The test was started at 7 a. m. The voltage held steady at 117 until 8:20 a. m., then it gradually began to go down until 10 a. m., when it reached 115 volts; then suddenly it dropped to 110 volts and then 108 volts. I couldn't imagine what was the matter. The engine speed remained constant and the load the same. Finally a man came in with a bucket and threw resin on the belt. Immediately the voltage went back to 117 volts, and re-

mained there until in the afternoon there was a repetition of this performance.

The main belt from the engine to the line shaft slipped 7.7 per cent, which made of course the loss at every machine. Thus a lathe was doing 7.7 per cent less work than it should with corresponding loss in production. The storage battery charging room suffered the most. They were drawing a charging current of 180 amperes, at 117 volts; when the voltage dropped to 110 volts the current dropped to 145 amperes, and when the voltage reached 108 volts the charging current was 130 amperes. I found afterwards that one of the plant men was the official resin thrower.

Primarily, a belt inclined at an angle of 60 deg. is a rather poor proposition. Matters could be made considerably better by an idler pulley used as a belt tightener. The whole load and plant was an ideal proposition for purchasing current from a Central Station, but with that engine, an investment in a 75-kw. generator and motor drive would soon pay for itself.

BABBITT SEPARATOR

BY J. V. HENRY

An effective machine for reclaiming babbitt which drops on the floor around furnaces and tables is shown in the illustration. It is an improvement over the method of reclaiming babbitt from floor sweepings by placing the sweepings in the melting pot, and skimming the dirt off the top. With the use of the separator there is less danger of foreign substances getting into the babbitt and affecting its quality.

The construction of the machine is plainly indicated. After sufficient sweepings have accumulated in the large funnel to warrant operation, they are lowered into the first drum by means of the damper and small funnel and the machine started. As the drum revolves the larger pieces

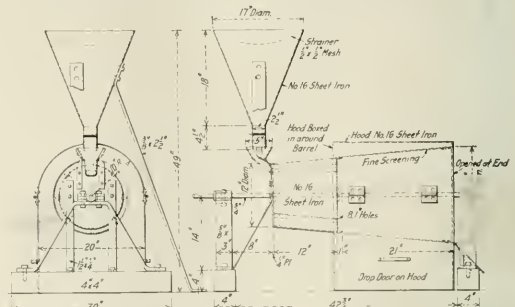

Machine Used for Separating Babbitt from Floor Sweepings

of babbitt coming in contact with the 1-in. by 1-in. angles riveted to the barrel, are broken up, liberating any dirt that they might contain. The babbitt and dirt then pass through the eight 1-in. holes into the second drum made of fine screen, from which the dirt drops to the floor while the babbitt passes out of the end and down the chute. The screen drum is covered with a hood which prevents any dust from flying around the shop.

The machine may be either belt or motor driven and should revolve at about 25 r.p.m.

INCREASED RAILWAY FARES IN IRELAND.—The recent increase in ordinary passenger fares by 50 per cent on the railways in Great Britain was ordered to apply to Ireland from June 1.

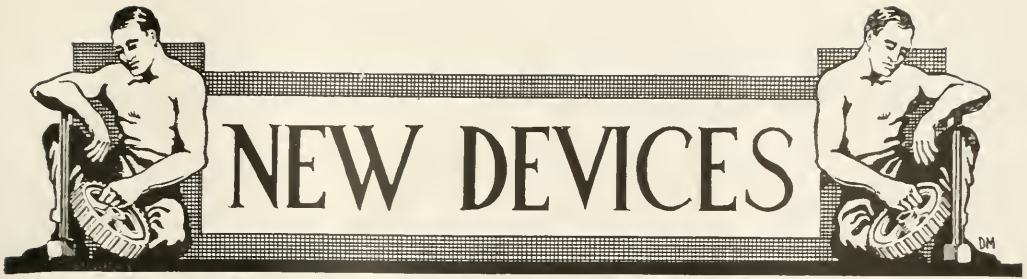

SYSTEM FOR PREPARING JOURNAL BOX PACKING

The preparation and the resaturation of waste used for packing journal boxes when done by the usual method is an unpleasant job. Most roads require that waste shall be submerged in oil for 24 hours and drained from 24 to 48 hours. Often packing is made up in large quantities and becomes very dry before being used; this results in hot boxes or a waste of lubricant, through the excessive use of free oil, either of which is costly.

A system which overcomes the disadvantages of ordinary

front provided for that purpose. The tanks are manufactured in various sizes. All are closely riveted and soldered and are fitted with dust-proof covers.

The use of properly saturated waste without the addition of free oil is recognized as the most desirable practice for insuring efficient and economical lubrication. The Milwaukee saturating system helps toward the attainment of that end by reducing the time and labor required for the proper preparation of packing.

BAKER ROD DRILL

A new rod drill (type 4-K) has been built recently for the use of the United States Engineering Corps abroad by Baker Brothers, Toledo, Ohio. This is a special machine for railway work, and consists of two high speed drills adjustable along the base to bore rods of different lengths. The general arrangement of drills and base is shown in the illustration.

The two units used in making up the rod drill are the standard No. 513 Baker drills, and both machines are driven by independent motors. A special traversing motor moves either or both of the drills horizontally as may be desired.



Milwaukee Waste Saturating Tanks

vats has been placed on the market by the Milwaukee Tank Works, Milwaukee, Wis. This consists of tanks with an oil reservoir in the lower part and a waste compartment in the top. A pump is attached to the tank, so that the oil can readily be lifted to the upper section. When it is desired to prepare some packing, the waste is placed in the top of the tank and the oil is pumped over it. When it has been immersed for a sufficient length of time, a valve is opened to allow the oil to flow into the bottom tank, leaving the waste to drain on the screen. If the waste becomes too dry it can be saturated again without removing it from the vat. A gage stick at the rear of the tank shows the amount of oil remaining in it. The bottom of the tank can be cleaned, if necessary, through an opening in the

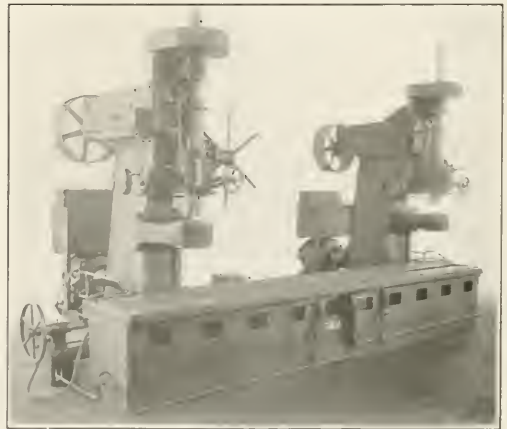

Baker Brothers 4-K Rod Drill

Both units are equipped with a steady support for the boring bar and the table is arranged with ample pockets for receiving the lubricant. Ample T-slots are provided for clamping the rods to the table.

The design of this drill is such that in boring, drilling, forming and facing, a 5/8-in. high speed drill may be driven

to the limit of its efficiency. Particular attention has been given to the location of all operating levers, which are so placed as to minimize the work of the operator in changing feeds, speeds and making table adjustments. The machine is started and stopped from the front. Instantaneous change from drilling to reaming speeds is also provided.

A constant speed drive is furnished through a train of hardened gears running on annular ball bearings encased in an oil-tight box. Annular ball bearings are used throughout this machine. The feed arrangement is simple and rugged, and 24 different feeds in all are provided, 12 drilling and 12 reaming feeds. The feed rack is of steel and the feed pinion meshing with it is cut direct on the shaft. A large bronze worm gear with provision for securing uniform wear, and a safety pin to protect the feeding mechanism from abuse is provided. The shear pin has been set to shear at 14,000 lb. There is an automatic depth stop with fine adjustment. Capstan handles are provided for rapid vertical traverse; in addition, hand worm feed is provided.

The machine is started and stopped by means of a shifting belt on tight and loose pulleys, the loose pulley running on ball bearings. A spring device holds the belt securely in position. In the "off" position a brake is applied in such a manner as to quickly stop and hold the spindle. This not only saves time, but is a safeguard to the workman while changing tools. The following are the general dimensions of the machine:

Capacity, high-speed drill in solid steel, 5 in.; distance, center of spindle to face of column, 18 in.; distance, end of spindle to plain table, 45 in.; length of feed, 18 in.; diameter of spindle sleeve, 5.25 in.; Morse taper in spindle, No. 6; twelve drilling feeds, .006 to .032; twelve reaming feeds, .020 to .108; eight speed changes, 11 to 151; driving pulley, 20 in. by 5/4 in.; speed of pulley, 600 r.p.m.; size of motors required, 15 hp.—1,200 r.p.m.

NEW TYPE OF MACHINE FOR WOODWORKING

In woodworking shops there is still a large amount of hand planing done, even though the plant may have a very complete equipment of machinery. Some jobs are too small for the jointer and if a single piece is to be surfaced, taking it to the machine is a wasteful practice due to the time lost on the trip and waiting for the machine to come up to speed. The demand for a tool to handle small pieces and short runs has led to the development of the Wallace bench planer, an illustration of which is shown in connection with this article.

This machine will do surfacing, mitering, beveling, joint-

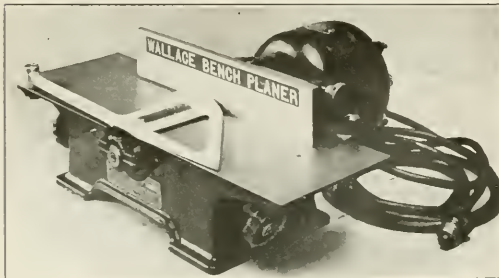

A Portable Wood Planer

ing, rabbeting, etc. While it is large enough to accommodate three quarters of the power planing done in the average shop it will handle pieces as short as three inches in length. It will take heavy cuts in hard or soft wood, yet requires so little power that it can be connected to an ordinary electric light socket. It takes a finish cut so smooth

that no sand papering is needed. The entire machine is portable and does not require fastening to the bench.

The table of the Wallace bench planer is 19 in. long and is adjustable for any depth of cut. The throat opening is less than 1 in. The knives are 4 in. wide and are completely protected by the flap and shutter guards. The machine is regularly furnished with the cutter head direct connected to a one-fourth horse power motor for either alternating or direct current. If desired, however, it can be supplied with a pulley and countershaft for belt drive. The fence is adjustable to any angle for beveling and similar work. The bench planer is used by a large number of pattern and cabinet makers and several have been installed in railroad shops. The manufacturers of the machine are J. D. Wallace & Company, Chicago.

ANDERSON VALVE GEAR

A new form of valve gear has been devised and a patent applied for by J. A. Anderson, master mechanic, Baltimore & Ohio, Grafton, W. Va. The motion of the valve is the same as that obtained with the usual form of Stephenson gear, but the eccentric motion work is removed from between the frames and applied to the outside, using a double crank arm as a substitute for the eccentrics and straps. This affords an outside valve motion with a variable lead.

Stated briefly, the special features of this form of valve gear are its simplicity, accessibility for oiling, ease of maintenance and variable lead. By eliminating the use of eccentrics and straps, the amount of friction is reduced and there are no heavy revolving parts. A further advantage is the elimination of heavy rocker boxes and long transmission rods, which in most cases are curved and subject to considerable distortion. Of course, the removal of the motion

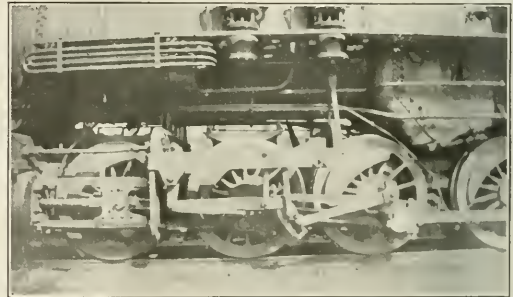

Fig. 1—The Anderson Valve Gear Applied to a B. & O. Locomotive

work from between the frames permits better bracing of the locomotive frames, which in turn has a tendency to reduce frame breakage.

A Baltimore & Ohio locomotive is shown in Fig. 1 equipped with the Anderson valve gear, and Fig. 2 shows in plan and elevation how the gear is applied.

The principal part of the gear is a double crank arm fastened to the end of the main crank pin, as shown. This crank arm is forged in one piece and has two pins which take the place of eccentrics. They are located in the following manner: Keyway points are located on the axle, the same as for the Stephenson gear; lines are drawn from the center of the axle through these points and distances spaced off equal to one-half the valve travel, or the radius of eccentricity; then the crank arm is designed to have arms so located as to fall on lines through these points parallel to the center line of the axle, the smaller arm being extended from the outer end of the pin on the crank pin arm. The

TRUCK BOX LUBRICATOR

The advantages resulting from the use of hard grease on locomotive journal and crank pin bearings are well known and it would probably be used even more than it is except for the difficulty in applying it to certain bearings. Hard grease has been used for the lubrication of locomotive driving journals since 1905 and at the present time it is prob-

motion is transmitted through a link similar to that used in the eccentric link motion. The links are raised and lowered in the same way as with the inside eccentric motion, except for the difference in the location of the reverse shaft arms.

The double eccentric crank arms are designed to be interchangeable on each class of locomotive. After once applying in accordance with specifications there is no necessity

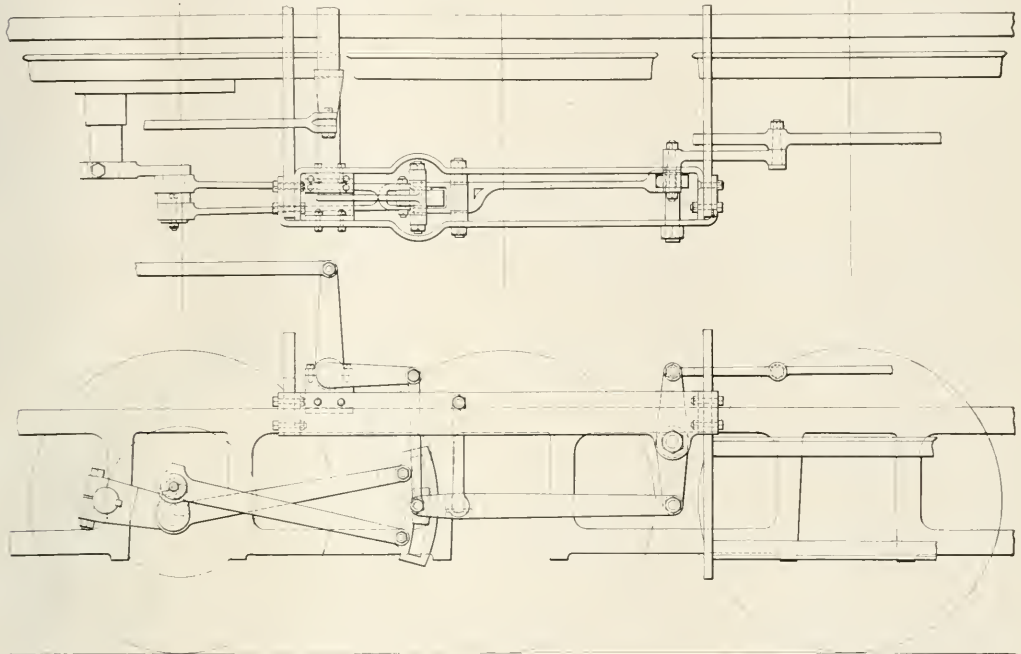

Fig. 2—Plan and Elevation of Anderson Valve Gear

for any changes or adjustments such as are frequently necessary in the Stephenson gear, due to eccentric wear.

In comparing this device with other outside locomotive valve gears, the double crank arm makes it possible to take all the motion transmitted to the valve from the axle and secure a variable lead.

The Baltimore & Ohio locomotive shown was equipped with the Anderson valve gear at the Glenwood shops, Pittsburgh, Pa., and has been in service for several months. It is understood that plans are under way for applying the valve gear to three different classes of locomotives for a more extensive test.

FUEL OIL CONSUMPTION BY RAILROADS IN 1917.—The Geological Survey reports that the immense increase in railroad traffic has increased correspondingly the quantity of petroleum consumed as locomotive fuel in 1917, despite the mounting cost and growing scarcity. Statistics compiled from reports submitted by all railroad companies that operated oil-burning locomotives in the United States show that the quantity of fuel oil consumed by them in 1917 was 45,707,082 barrels, or 8.5 per cent over 1916, and a larger consumption than in any other year. The total distance covered by oil-burning engines in 1917 was 146,997,144 miles, and the average distance covered per barrel of fuel consumed was 3.2 miles. Oil-burning locomotives were run on 32,431 miles of road in 21 states.

able that 90 per cent of the locomotives in the United States and Canada have driving journals fitted for the exclusive use of hard grease as a lubricant.

Up to date, however, very little has been done to extend the use of hard grease to engine truck and trailer journals.

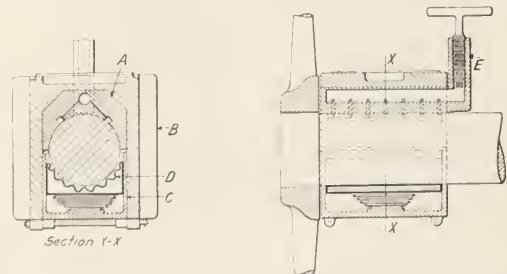

The Martin Truck Box Lubricator

The accompanying illustration shows a hard grease truck box lubricator patented by J. C. Martin, Oakland, Cal.

It is generally agreed that whenever possible the best place to apply lubricant to a journal is at the top, where the load is carried. This is especially true of engine truck and

trailer journals where there are no reciprocating parts and the constant load tends to pinch out what lubricant is between the bearings and prevent any more from getting in. This condition is met in the Martin bearing by forcing the hard grease into the bearing from the top. Referring to the illustration, *A* is the special crown brass bearing with a centrally cored out section and a series of channels connecting it with longitudinal grooves on either side of the center line and near the top of the journal. The hard grease is inserted through a threaded extension of the cored out section of the bearing, which is fitted with a screw plug, as indicated at *E*. The journal bearing *A* fits in the box *B*, in the customary manner. The cellar *C* is provided with a corrugated tray *D*, which is held against the bottom of the journal by a coil spring. This tray serves the purpose of conserving the lubricant as it passes downward to the under side of the journal and allows it to be used over again.

In operation the cored out section of the journal bearing is filled with hard grease by means of the plug, and as the locomotive is run the grease gradually works to the bottom of the journal, filling the corrugated tray, thus insuring economical and complete lubrication of the bearing.

It is claimed for the Martin lubricator that it reduces locomotive failures due to melted out truck bearings, that it requires but little attention and materially reduces the cost of lubricating truck journals. In service the operation of the device has proved satisfactory during a trial of nearly two years' duration.

EXTENSION BORING MILL

The 28- to 42-ft. extension boring and turning mill illustrated, was built recently by the Niles-Bement-Pond Company, 111 Broadway, New York, for arsenal work. While this machine would not be applicable to railway shop work, it is of interest because of its immense size. The swing of the machine is 28 ft. 2 in. with the housings forward, and 42 ft. 4 in. with the housings back. The maximum height under the tool holders is 10 ft. and the bar travel is

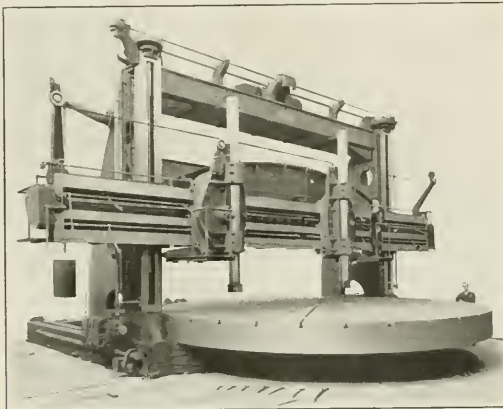

28-Ft. Boring Mill for Arsenal Work

84 in. The table is driven by a 16-hp. motor through a double pinion drive. A 25-hp. motor is used for elevating the crossrail and a 15-hp. motor for fast traversing the bars and saddles. A separate 15-hp. motor is used for traversing the housings.

The crossrail has two heads with octagon bars 10 in. across the flats. The crossrail is 48 in. in width and 54 in. in depth from front to back.

The table is designed to carry safely a load of 300,000 lb. in addition to its own weight. It is driven by two forged steel pinions, one located on each side. The heads on the crossrail are provided with platforms for the operator, and an idea of the size of the machine may be obtained by noting the relative size of the two operators in the illustration. The adjustment of feeds and rapid traverse for bars and saddles is controlled from the platforms. The main driving motor is also controlled from these platforms, as well as from stations at each side of the machine. Push button control is provided for all motors.

STA-RITE UNCOUPLING LEVER ATTACHMENT

The reports of the division of safety of the Interstate Commerce Commission indicate that uncoupling chains are responsible for more than half the defects of the uncoupling mechanism. The adoption by the railroads of other devices to replace uncoupling chains has been recommended by the division of safety. A simple and efficient substitute for the uncoupling chain is now being made by the Railway Devices Company, St. Louis. This device which is known as the Sta-

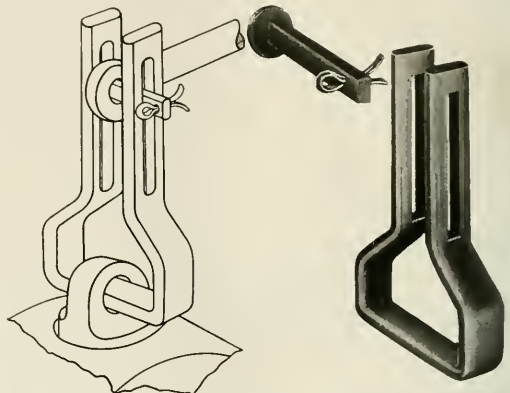

Method of Application and Details of Sta-Rite Uncoupling Attachment

Rite Uncoupling Lever Attachment requires no change in the M.C.B. uncoupling levers for its application. It consists of but three pieces, the link and pin which are of cast steel and the cotter pin. The construction is such that the parts cannot get out of place, or cause trouble due to kinking or fouling, and sufficient flexibility is provided to take care of all movements of the coupler. The design of the device and the method of application are clearly shown in the illustration above.

WHEN CARBON MONOXIDE IS FATAL.—Carbon monoxide has an avidity for hemoglobin, the red coloring matter of the blood, with which it forms the same combination as does oxygen, only 250 times as powerful. However, this combination is not permanent and a man brought out to the fresh air, or to whom air mixed with oxygen can be administered, will generally recover if exposure is within the following limits. As a rough estimate, it may be stated that usually a man will die who has breathed 0.2 per cent of carbon monoxide mixed with air which is in other respects normal, for four or five hours, or 0.4 per cent for one hour. With from two to five per cent of carbon monoxide death follows almost as quickly as in drowning.—*Journal of the American Medical Association.*

Railway Mechanical Engineer

(Formerly the RAILWAY AGE GAZETTE, MECHANICAL EDITION
with which the AMERICAN ENGINEER was incorporated)

PUBLISHED ON THE FIRST THURSDAY OF EVERY MONTH BY THE
SIMMONS-BOARDMAN PUBLISHING COMPANY

EDWARD A. SIMMONS, *President* M. H. WIUM, *Secretary*
HENRY LEE, *Vice-President and Treasurer* L. B. SHERMAN, *Vice-President*
WOOLWORTH BUILDING, NEW YORK, N. Y.
F. H. THOMPSON, *Business Manager*, CHICAGO.

Chicago: Transportation Bldg. Cleveland: Citizens' Bldg.
Washington: Home Life Bldg.
London: Queen Anne's Chambers, Westminster.

ROY V. WRIGHT, *Editor*
R. E. TRAYER, *Managing Editor*

C. B. PECK, *Associate Editor* E. L. WOODWARD, *Associate Editor*
A. F. STUBBING, *Associate Editor* C. W. FOSS, *Associate Editor*

Repairs of locomotives are now being rushed. Frank McManamy, manager of the locomotive section of the Railroad Administration, says that on the government-controlled roads about 4,800 engines are passing through the shops each week, or 700 more than a year ago.

The salary of the chief inspector of locomotive boilers of the Interstate Commerce Commission is to be raised from \$4,000 to \$5,000 a year, the salaries of the two assistant inspectors from \$3,000 to \$4,000, and of the district inspectors from \$1,800 to \$3,000; all by virtue of a law passed by the Lower House of Congress, on June 5, and by the Senate, on June 18.

A senior inspector of motive power is wanted by the United States Civil Service Commission, for a position in the Division of Valuation, of the Interstate Commerce Commission, Eastern district; salary \$1,800 a year. Applications will be received up to July 16. Applicants must be between 25 and 60 years old and the examination will cover the qualifications for all grades in this department up to a salary of \$3,600 a year.

The United States Government is expected to place large orders shortly for additional cars and locomotives for service on the military railway lines in France. General Pershing has called to Washington requirements for locomotives, cars and steel which will greatly increase the orders already placed by S. M. Felton, director general of military railways, which include about 30,000 cars and 2,000 locomotives. The number of cars and engines is understood to be so large as to cause some perplexity on the part of the authorities in charge of the apportionment of the steel supply.

Scarcity of steel is now so very general that the amount which may be used for railroad purposes will be determined only after careful scrutiny. An agreement has been entered into with a committee of the American Iron & Steel Institute under which the board will pass upon all applications for steel products and pig iron. When a railroad requires steel, the need for it must be first approved by the regional director, and it must then be passed upon by J. Leonard Replogle, director of steel supply for the War Industries Board, who assigns the manufacture to one of the various plants. The steel required for the government cars and locomotives was allotted by Mr. Replogle through the American Iron & Steel Institute.

Entered at the Post Office at New York, N. Y., as mail matter of the second class.

Subscriptions payable in advance and postage free: United States, Canada and Mexico, \$2.00 a year; Foreign Countries, \$3.00 a year; Single Copy, 20 cents.

WE GUARANTEE that of this issue 6,900 copies were printed; that of these 6,900 copies 5,870 were mailed to regular paid subscribers, 144 were provided for counter and news companies' sales, 195 were mailed to advertisers, 180 were mailed to exchanges and correspondents, and 511 were provided for new subscriptions, samples, copies lost in the mail and office use; that the total copies printed this year to date were 56,300 an average of 8,043 copies a month.

The RAILWAY MECHANICAL ENGINEER is a member of the Associated Business Papers (A. B. P.) and of the Audit Bureau of Circulations (A. B. C.).

Railroad Men Thanked

Director General McAdoo has issued a circular expressing his appreciation of the patriotism of the railroad employees of the country who subscribed for Liberty Bonds and urging them to invest in War Savings Stamps. The circular says, in part:

"I am deeply gratified to learn of the large number of railroad employees who have subscribed for the third issue of Liberty Bonds. . . . A large number of railroad employees will receive substantial amounts of back pay. . . . I earnestly urge upon every railroad employee who has thus secured increases in pay to invest as much as he possibly can in the War Savings Stamps."

The Status of the Freight Car Orders

Although all of the specialties had not yet been ordered, the Director General's office at Washington announced on June 19 that the first of the 31,000 freight cars ordered from the American Car & Foundry Company had been completed. This is merely a sample car built for inspection purposes and does not necessarily conform to the final specifications so far as specialties are concerned.

The proposed order for 2,000, 40-ton box cars to the Barney & Smith Car Company, which was shown in the list of car orders published last month, was not placed. Instead, 1,000 of these cars were added to the order of the American Car & Foundry Company, 500 to that of the Keith Car & Manufacturing Company, and 500 were ordered from the McGuire-Cummings Manufacturing Company.

It is understood that orders for 50,000 additional cars, to include stock, refrigerator, general service and flat cars, are to be placed after the delivery of the first cars ordered is well along, from plans and specifications which have already been prepared by the car and locomotive standardization committee.

Headlight Order Effective July 1

The Interstate Commerce Commission's order of October 11, 1915, requiring locomotives to be equipped with high-power electric headlights, which has been three times extended, became effective on July 1. It applies to all new locomotives and all locomotives sent to the shop for general or heavy repairs after that date; and all locomotives must

be equipped by July 1, 1920. About 40,000 engines are now equipped with high-power lights, which leaves about 26,000 more to be equipped. The new standard locomotives recently contracted for by the Railroad Administration are to be equipped with lights ordered from the Pyle-National Electric Headlight Company, but on other locomotives the roads may use any light they desire, if it complies with the commission's order. This requires for road locomotives a light "which shall afford sufficient illumination to enable a person in the cab who possesses the usual visual capacity required of locomotive engineers, to see in a clear atmosphere, a dark object as large as a man of average size standing erect at a distance of at least 800 feet ahead and in front of such headlight." For yard locomotives the distance is 300 feet.

Officers Required for Railway Troops

S. M. Felton, director general of military railways, has issued a new call for railway men for service on the American lines of communication overseas.

With the growth of our armies in France many additional officers for railroad troops that are now forming and which will be formed in the near future will be required. The director general military railways realizes the necessity of retaining American railroad officers in their present positions and that the operation of the American railroads must be maintained, but there is such necessity for officers for railroad troops in France that he is calling for *experienced railroad men who are now employed in other active pursuits*. He has requested that railroad officers send to him the names of their acquaintances who would be possible candidates.

The following statement gives an outline of the qualifications required; the official rank for which commissions will be issued, with their several rates of pay; the commutation of quarters being allowed when officers are maintaining their families in this country:

Qualification	Rank	Rate of pay		Commutation of quarters		Total	
		U. S.	Foreign	U. S.	Foreign	U. S.	Foreign
Asst. general manager.....	Major	\$3,000	\$3,300	\$720	\$3,720	\$4,020	
General superintendents.....	Major	3,000	3,300	720	3,720	4,020	
Superintendents—Motive power.....	Major	3,000	3,300	720	3,720	4,020	
Division superintendents.....	Captain	2,400	2,640	576	2,976	3,216	
Master mechanics.....	Captain	2,400	2,640	576	2,976	3,216	
Engrs. maintenance of way.....	Captain	2,400	2,640	576	2,976	3,216	
Trainmasters.....	1st Lt.	2,000	2,200	432	2,432	2,632	
Div. engrs.—maintenance of way.....	1st Lt.	2,000	2,200	432	2,432	2,632	
Chief dispatchers.....	1st Lt.	2,000	2,200	432	2,432	2,632	
Road foremen of engines.....	1st Lt.	2,000	2,200	432	2,432	2,632	
General yardmasters.....	1st Lt.	2,000	2,200	432	2,432	2,632	
Enginehouse and shop foremen.....	1st Lt.	2,000	2,200	432	2,432	2,632	
Asst. division engineers.....	2nd Lt.	1,700	1,870	288	1,988	2,158	
Yardmasters.....	2nd Lt.	1,700	1,870	288	1,988	2,158	
Supervisors and roadmasters.....	2nd Lt.	1,700	1,870	288	1,988	2,158	
Asst. enginehouse and shop foremen.....	2nd Lt.	1,700	1,870	288	1,988	2,158	

In addition to the above there is a small allowance made for heat and light which varies according to the location of station and season of the year.

It is desired that as many men as possible communicate with the Director General Military Railways' office, Sixth and B streets, N. W., Washington, D. C., and that in these communications they give in detail their railroad experience and their references. The call for these men is pressing and it is hoped that there will be a hearty response.

U. S. Employment Service to Regulate Labor

The government is to control labor distribution as completely as possible. After August 1, industries employing more than 100 men will be required to employ common labor through the United States Employment Service. The Department of Labor aims at the elimination of private competition for workers, and all government departments and

boards concerned with war production and having to do with the letting of contracts for war materials have agreed to its plans. Felix Frankfurter, assistant to Secretary of Labor, is chairman of the "War Policies Board" of the Department of Labor. All war industries will be requested to facilitate in the centralization program by stopping independent labor recruiting activities which have demoralized the labor market, caused a tremendous labor turnover and kept much available labor constantly jumping from one place to another.

President Wilson on June 17 issued a proclamation approving the plan and urging all employers engaged in war work to refrain from recruiting un-killed labor in any manner except through the central agency.

MEETINGS AND CONVENTIONS

The Traveling Engineers' Association.—The Railroad Administration has authorized the Traveling Engineers' Association to hold the next convention at Chicago, Ill., commencing September 10, 1918. The following are the subjects to be discussed:

(1) Fuel Economy under the following heads (a) Value of present draft appliances; can they be improved to effect fuel economy? (b) Best practice for handling locomotives at terminals to reduce coal consumption. (c) How can engineers and firemen effect the greatest saving of fuel when locomotives are in their charge? (d) Whether it is most economical to buy cheap fuel, at a low heat value or a higher priced fuel at a greater heat value. (e) The most economical method of weighing fuel when delivered to locomotives in order that individual records of coal used by engineers and firemen may be kept. (f) Superheat applied to locomotives as effecting coal consumption.

(2) Engine Failures—causes and remedies, best methods of investigating same, and placing responsibility.

(3) The use of superheat steam in slide valve engines. Drifting, relief and by-pass valves or the absence of any one or all on superheat locomotives equipped with piston valves.

(4) Cab and cab fittings on modern locomotives, from the viewpoint of the engineer.

(5) How can the traveling engineer and general air brake inspector best co-operate to improve and maintain the air brake service?

There will be opportunity for such other matters as may be considered of interest to the association and the railroads under changed conditions.

The following list gives names of secretaries, dates of next or reg. meetings and places of meeting of mechanical associations:

AIR BRAKE ASSOCIATION.—F. M. Nellis, Room 3014, 165 Broadway, New York City.

AMERICAN RAILROAD MASTER TINNERS', COPPERSMITHS AND PIPEFITTERS ASSOCIATION.—O. E. Schlink, 485 W. Fifth St., Peoria, Ill.

AMERICAN RAILWAY MASTER MECHANICS ASSOCIATION.—V. R. Hawthorne, Karpen Bldg., Chicago.

AMERICAN RAILWAY TOOL FOREMEN'S ASSOCIATION.—R. D. Fletcher, Belt Railway, Chicago.

AMERICAN SOCIETY FOR TESTING MATERIALS.—Prof. E. Marburg, University of Pennsylvania, Philadelphia, Pa.

AMERICAN SOCIETY OF MECHANICAL ENGINEERS.—Calvin W. Rice, 29 W. Ohio St., New York.

ASSOCIATION OF RAILWAY ELECTRICAL ENGINEERS.—Joseph A. Andreuccetti, C. & N. W., Room 411, C. & N. W. Station, Chicago.

CAR FOREMEN'S ASSOCIATION OF CHICAGO.—Aaron Kline, 841 Lawlor Ave., Chicago. Second Monday in month, except June, July and August, Hotel Morrison, Chicago.

CHIEF INTERCHANGE CAR INSPECTORS' AND CAR FOREMEN'S ASSOCIATION.—W. R. McMind, New York Central, Albany, N. Y.

INTERNATIONAL RAILROAD MASTER BLACKSMITHS ASSOCIATION.—A. L. Woodworth, C. H. & D., Lidia, Ohio.

INTERNATIONAL RAILWAY FUEL ASSOCIATION.—J. C. Crawford, 542 W. Jackson Blvd., Chicago.

INTERNATIONAL RAILWAY GENERAL FOREMEN'S ASSOCIATION.—William Hall, 1126 W. Broadway, Winona, Minn.

MASTER POLLEMAKERS ASSOCIATION.—Harry D. Vought, 95 Liberty St., New York.

MASTER CAR BUILDERS ASSOCIATION.—V. R. Hawthorne, Karpen Bldg., Chicago.

MASTER CAR AND LOCOMOTIVE PAINTERS ASSOCIATION OF U. S. AND CANADA.—A. P. Dane, B. & M., Reading, Mass.

NIAGARA FRONTIER CAR MEN'S ASSOCIATION.—George A. J. Hoehrebe, 623 Brisbane Bldg., Buffalo, N. Y. Meetings, third Wednesday in month, Statler Hotel, Buffalo, N. Y.

RAILWAY STOREKEEPERS ASSOCIATION.—J. P. Murphy, Box C, Colliwood, Ohio.

TRAVELING ENGINEERS ASSOCIATION.—W. O. Thompson, N. Y. C. R. R., Cleveland, Ohio. Next meeting, September 10, 1918, Chicago.

PERSONAL MENTION

FEDERAL ADMINISTRATION APPOINTMENTS

C. B. DAILEY, assistant to the director of purchases of the Southern Pacific, has been appointed assistant manager of the procurement section of the Central Advisory Purchasing Committee of the Railroad Administration.

G. M. DAVIDSON, chemist and engineer of tests of the Chicago & North Western, at Chicago, has been appointed a member of the inspection and test section of the United States Railroad Administration for the western region.

B. J. FEENEY, traveling engineer of the Yazoo & Mississippi Valley, has been appointed supervisor of the Fuel Conservation section of the United States Railroad Administration, for the Southern Regional district, with office at Atlanta, Ga. Mr. Feeny was for nine years employed as a machinist, locomotive fireman and engineman on the Chicago and Kentucky divisions of the Illinois Central, then for 10 years was a traveling engineer on the Kentucky division, and for six years was traveling engineer at the Memphis Terminal, in charge of fuel economy and smoke prevention. He was with the Yazoo & Mississippi Valley since 1916 as traveling engineer, his office being at Memphis.

H. L. INGERSOLL, assistant to the president of the New York Central, has been appointed mechanical assistant in the office of the eastern regional director in New York.

C. T. MARKEE, general foreman and chief locomotive inspector of the Chicago & North Western, and J. A. Rickabaugh, supervising inspector of the Pennsylvania, have been appointed, respectively, chief construction inspectors of locomotives and cars for the Inspection and Test Section of the Railroad Administration. They will have charge of the inspectors at the various plants throughout the country where the Administration has purchased equipment.

H. B. MACFARLAND, engineer of tests of the Atchison, Topeka & Santa Fe at Chicago, has been appointed a member of the inspection and test section of the United States Railroad Administration for the western railroad region. Mr. MacFarland has also been assigned to one of the 18 districts which have been created for the inspection and testing of materials which will be used in the construction of the car and locomotive equipment recently ordered by the government. His district will comprise southern Ohio and the territory tributary to St. Louis, Mo.

FRANK McMANAMY has resigned as chief inspector of locomotive boilers of the Interstate Commerce Commission and has been appointed mechanical assistant to the director of the Division of Operation of the Railroad Administration, effective on July 1, succeeding H. T. Bentley, resigned. In this position he will have jurisdiction over the Car Repair and Inspection and Test Sections and general charge of matters pertaining to locomotive and car equipment. Mr. McManamy has also been manager of the locomotive section of the division of operation.

H. C. PEARCE, general purchasing agent of the Seaboard Air Line, has been placed in charge of the procurement section of the Central Advisory Purchasing Committee of the United States Railroad Administration, with headquarters at Washington, D. C. This section has been established for the purpose of facilitating the procurement and delivery of the material required in the production of the cars and locomotives ordered by the Railroad Administration.

L. G. PLANT has been appointed progress engineer of the procurement section of the Central Advisory Purchasing Committee of the United States Railroad Administration.

H. E. SMITH, engineer of tests of the New York Central, has been named as chief materials inspector of the Inspection and Test Section of the Railroad Administration. He will have charge of the inspection and testing of all the material purchased for use of the Railroad Administration.

H. C. WOODBRIDGE, assistant to general manager of the Buffalo, Rochester & Pittsburgh, has been appointed regional supervisor in the Fuel Conservation section of the Railroad Administration, with headquarters at Philadelphia, Pa.

F. ZELENY, engineer of tests of the Chicago, Burlington & Quincy, at Aurora, Ill., has been assigned to one of the 18 districts created by the inspection and test section of United States Railroad Administration, his district comprising Chicago and surrounding territory.

GENERAL

H. C. BENTLEY, superintendent of motive power of the Chicago & North Western, who has been serving at Washington as mechanical assistant in the Division of Operation of the Railroad Administration, has resigned and has returned to his office in Chicago. Mr. Bentley's resignation was due to ill-health. As chairman of the committee on standards, he has had active charge of preparing standards for government engines and freight cars.

H. C. MAY, superintendent of motive power of the Chicago, Indianapolis & Louisville, has been appointed general manager, with office at La Fayette, Ind.

MASTER MECHANICS AND ROAD FOREMEN OF ENGINES

JOHN VASS, road foreman of engines of the Grand Trunk, at Battle Creek, Mich., has been appointed assistant master mechanic of the Ontario lines, with headquarters at Allandale, Ont., in place of J. R. Donnelley, retired.

PURCHASING AND STOREKEEPING

H. P. McQUILKIN has been appointed assistant general storekeeper of the Baltimore & Ohio, with office at Baltimore, Md., succeeding E. W. Thornley, who has been furloughed to accept service in the office of the Allegheny Regional Purchasing Committee.

OBITUARY

C. J. STEWART, mechanical superintendent of the New York, New Haven & Hartford, with headquarters at New Haven, Conn., died recently at Twin Lakes, Conn., at the age of 51. Mr. Stewart began railway work with the Erie as a caller and subsequently served consecutively as engine despatcher, special apprentice, fireman, engine inspector and foreman on that road. He then entered the service of the Delaware, Lackawanna & Western as machinist, and later served as foreman and general foreman until 1905, when he went to the Central New England as master mechanic.

In 1913 he was appointed assistant mechanical superintendent of the New York, New Haven & Hartford, at New Haven, Conn., and in 1917 was appointed mechanical superintendent.



C. J. Stewart

SUPPLY TRADE NOTES

The United States Metallic Packing Company, Philadelphia, Pa., has moved its offices in that city to 221 North Thirteenth street.

The Sprague Electric Works of the General Electric Company announces the removal of its Boston office from 201 Devonshire street to 84 State street.

The H. W. Johns-Manville Company announces that after July 1, 1918, its Houston office will be located at 424-426 Washington avenue, Houston, Texas.

W. M. Bosworth has resigned as mechanical engineer of the Norfolk Southern to go into the engineering department of the Underfeed Stoker Company, Chicago.

The Burden Sales Company, Inc., New York, announces the removal of its office from 30 Church street to the Forty-second street building, 30 East Forty-second street.

Stanley W. Midgley, general sales manager of the Acme Supply Company, Chicago, has been appointed western representative in charge of railroad sales of the Liberty Steel Products Company, at Chicago. He was born at Chicago in 1875. After completing his education at the Lewis Institute (Chicago) he entered the sales department of the Great Western Cereal Company, having charge of the wholesale trade, with headquarters at Chicago. From 1902 to 1906, Mr. Midgley was general sales representative of the National Car Coupler Company, at Chicago, and from 1906 to 1914 he was western representative and western sales manager of the Curtain Supply Company, in the same city. Subsequently, he became general sales manager of the Acme Supply Company, with headquarters in Chicago, and remained with that company until his recent appointment as mentioned above.



S. W. Midgley

Charles P. Wright, sales representative of the American Brake Shoe & Foundry Company, at Chicago, has been appointed assistant to the vice-president, with headquarters at Chicago.

The Smith & Hemenway Company, of New York, has found it necessary to increase its output to meet the demands for "Red Devil" tools, and has erected a new building at Irvington, N. J., which is now being completed.

The directors of the Pullman Company on June 10 elected John F. Kane secretary, succeeding A. S. Weinsheimer, deceased, and Charles S. Sweet, formerly chief clerk in the president's office, was elected assistant secretary, succeeding Mr. Kane.

The new accessory plant of the American Locomotive Company at Richmond, Va., where piston valves, flexible staybolts, reverse gears and the other accessories are to be manufactured has been placed under the charge of Ross Anderson as manager.

The Parkesburg Iron Company announces the following changes among its resident sales managers, effective June 1, 1918: R. J. Sheridan, New York, and G. W. Denyven, Boston; after July 1, 1918, J. A. Kinkead, San Francisco. The other selling representatives remain the same as at present.

Joseph W. Weinland, sales manager of the brake beam department in the Chicago office of the American Steel Foundries, has been appointed district manager of the Liberty Steel Products Company, with headquarters at Chicago. Mr. Weinland was born at Chatsworth, Ill., on December 13, 1877. In 1902, he entered the service of the Western Steel Car & Foundry Company, as assistant purchasing agent. A considerable part of his time was spent on the Pacific coast, purchasing lumber to be used in the building of cars. Later he was promoted to purchasing agent of the Anniston, Ala., shop. For a period of five years following 1907, he was engaged in the construction and sale of 50 houses at Burnham, Ill. In 1912 he re-entered the railway supply field with the American Steel Foundries as sales manager in the brake beam department, which position he held until his recent appointment, as mentioned above.



J. W. Weinland

Charles A. McCune, for 12 years connected with the Commercial Acetylene Company of 80 Broadway, New York, has resigned to accept the position of sales engineer with the Page Steel & Wire Company, 30 Church street, New York. Mr. McCune was born in Jersey City, N. J., in 1879, and before entering the acetylene field was for several years connected with the Safety Car Heating & Lighting Company. He left in 1906 to take up the duties of assistant engineer with the Commercial Acetylene Company and since then has been actively engaged in this industry, his work in the greater part being devoted to the development and application of dissolved or compressed acetylene. In 1908, he perfected the first successful inverted acetylene burner and mantle for railroad car lighting purposes; this system being partly used on the Delaware, Lackawanna & Western until a few years ago, when the road practically went over to electric lighting. In 1916, Mr. McCune became chief engineer of the Commercial Acetylene Company. Mr. McCune will be succeeded by David Ahldrin, who was formerly connected with the A. G. A. Company and also the Commercial Acetylene Company.



C. A. McCune

The Q & C Company, of New York and Chicago, announces the appointment of the General Supply Company, Ltd., of Canada (358-360 Sparks street, Ottawa, Canada, with branch offices at Montreal, Winnipeg and Vancouver), as sole representatives in Canada.

Lloyd H. Atkinson has resigned his position as president of Atkinson & Utech, Inc., to become vice-president of the Air Reduction Company. He will, however, continue to serve on the board of directors of Atkinson & Utech, Inc. John J. Utech has been elected president to succeed Mr. Atkinson, and I. W. Glasel has become secretary and treasurer of the same company.

Frank W. Edmunds has been appointed general eastern sales manager of the Schroeder Headlight & Generator Company, of Evansville, Ind., with offices at 30 Church street,

New York. Mr. Edmunds, like many of the prominent men allied with the railway supply industry, began his business career as an office boy. His first employer was the man who put up the money for and built the famous "Monitor" of Civil War days, John A. Griswold, president of John A. Griswold & Co. With this company Mr. Edmunds stayed until it became the Troy Steel Company and then some years later liquidated. In the meantime he had been

made secretary, treasurer and general sales manager. He then became secretary of the Q & C Company at Chicago, acting also as western representative of the Pennsylvania Steel Company. He resigned from this position to become associated with the Dressel Railway Lamp Works, of New York, with which company he has been for 15 consecutive years, resigning as sales manager to accept the position mentioned above. The change became effective June 15. Mr. Edmunds served for years on various committees of the Railway Supply Manufacturers' Association and other associations, and is now the secretary-treasurer of the Signal Appliance Association.

A. B. Cole has been appointed assistant to manager of the Department of Publicity, Westinghouse Electric & Manufacturing Company, East Pittsburgh, Pa., to succeed M. C. Turpin, who has accepted a position in the Ordnance Department at Washington, D. C. Mr. Cole will have charge of the editorial work, including the preparation of literature, and supplying information to the press.

E. C. Peck, superintendent of the Cleveland Twist Drill Company at Cleveland, Ohio, has received an appointment as lieutenant-colonel in the engineering bureau of the ordnance department. Mr. Peck will have charge of the gages used in the production of munitions and kindred materials for the above department. His duties will be the supervision of design of gages and the settling of limits of variance which will be satisfactory to both manufacturer and the ordnance department itself.

The degree of Doctor of Engineering was conferred upon Walter V. Turner, manager of engineering for the Westinghouse Air Brake Company, by the University of Pittsburgh at the annual commencement, in recognition of his services to the engineering profession and to humanity. Mr. Turner

is considered the foremost pneumatic engineer in the world, and has over four hundred (400) inventions, covered by U. S. patents, in use on most railways of the world and in many large industrial plants.

The officers of the Chicago Malleable Casting Company, the Universal Draft Gear Attachment Company, and the Union Draft Gear Company, of Chicago, have formed a new corporation called the Allied Steel Casting Company of Chicago, and have purchased the Harvey, Ill., plant of the Whiting Foundry Equipment Company. The officers and organizations of the Chicago Malleable Casting Company, the Universal Draft Gear Attachment Company, and the Union Draft Gear Company are not changed, and the companies continue business as before.

A. S. Weinsheimer, secretary of the Pullman Company at Chicago, died on May 11, at the age of 72 years. Mr. Weinsheimer was born at Allentown, Pa., on May 12, 1846, and entered railway service in 1860 with the Lehigh Valley with which he was consecutively telegraph operator, freight clerk and ticket agent. From 1864 until the termination of the Civil War he was connected with the U. S. Army Quartermaster's department at various points on the Baltimore & Ohio. In 1865 he again entered the service of the Lehigh Valley in the coal department. He severed his connections with that company in 1871 to go with the Pullman Palace Car Company, at Chicago, and served it and its successor, the Pullman Company, until his death. He was cashier from September 1, 1875, to September 13, 1878, and from the latter date until his demise was secretary.

D. F. Crawford, who recently resigned as general manager of the Pennsylvania Lines West of Pittsburgh, has been elected vice-president of the Locomotive Stoker Company,

with headquarters at Pittsburgh, Pa. When in railway service, Mr. Crawford obtained extensive experience in both mechanical and executive positions. He was born at Pittsburgh, December 4, 1864, and attended the city and private schools and also the Pennsylvania Military College. He entered the service of the Pennsylvania System in July, 1882, in the freight department, transferring to the Altoona shops in December, 1885, as a special apprentice.

From 1889 to February 1, 1892, he was an inspector in the test department. In February, 1892, he was appointed assistant master mechanic of the Fort Wayne shops of the Pennsylvania Lines West of Pittsburgh. From July 1, 1895, to November 1, 1899, he was assistant to superintendent of motive power of the Northwest System of the Pennsylvania Lines West and on the latter date was made superintendent motive power of the same system, where he remained until August 1, 1903, when he was appointed general superintendent of motive power of the Pennsylvania Lines West of Pittsburgh. On January 1, 1917, he was promoted to general manager of the Lines West. Mr. Crawford was president of the Master Mechanics' Association in 1913, and in 1915 he was president of the Master Car Builders' Association. Since 1903, he has devoted much time and attention to the use and development of mechanical stokers



F. W. Edmunds



D. F. Crawford

for locomotives—and during this period developed the Crawford underfeed stoker, which is in extensive use on the Pennsylvania Lines West.

W. S. Murrian, superintendent of motive power and equipment of the Southern Railway, resigned on May 1, to become president and general manager of the Southern Locomotive Valve Gear Company, Knoxville, Tenn. Mr. Murrian learned the trade of machinist and worked in that capacity for several years. He came from the Union Pacific 15 years ago to the position of master mechanic of the Southern Railway at Alexandria, and was later transferred to Spencer, N. C., in the same capacity. At that time the Southern Railway was building the largest locomotive shops on the system at Spencer. After about two years' service at that point, Mr. Murrian was promoted, in 1906, to superintendent of motive power, with headquarters at Knoxville, Tenn. Mr. Murrian is personally interested in the specialties now being manufactured by the Southern Locomotive Valve Gear Company, and he is also thoroughly familiar with the efficiency of the commodities, the Southern Railway having adopted the Southern valve gear as its standard several years ago. Mr. Murrian succeeded General L. D. Tyson, now in active service in the United States Army, who had been president since the organization of the company.

The election of Stephen C. Mason, secretary of the McConway & Torley Company of Pittsburgh, as president of the National Association of Manufacturers, announced in last month's issue, is of more than ordinary interest to the railway and railway supply field, because Mr. Mason's entire business career has been confined to some branch of railroad work. He began on November 10, 1880, as a station agent in his home town, Lyndonville, Vt. As soon as he took up the work he learned telegraph operating, and before he was 20 years old was called to the headquarters of the Connecticut & Passumpsic Railroad, and made local freight agent at the headquarters of the division. After a few months' service there he was taken into the superintendent's office and made his private secretary. After the creation of the Interstate Commerce Commission, Mr. Mason applied for and secured a position with that body in Washington first in the office of the auditor of the commission, where he had charge of the tariffs filed by the railroad companies. Upon the creation of the division of statistics, of which Professor Henry C. Adams was the head, Mr. Mason was placed in that department, and remained there until 1896, when he occupied the position of assistant statistician. At that time he was offered a position with the McConway & Torley Company of Pittsburgh, which he accepted in January, 1896, and in whose service he has been continuously ever since. He has served in various capacities. His first experience was gained as a traveling representative, after which he acted as assistant to the superintendent of the plant, thus gaining a practical experience in the manufacturing operations. Later he was designated assistant to the president, an office which he held until the death of Charles B. Krauth, when he was elected secretary and later a member of the board of directors.



S. C. Mason

CATALOGUES

BRAKE BEAMS.—The American Steel Foundries, 30 Church street, New York, has recently issued a 34-page catalogue describing the Ajax and Hercules brake beams, the Simplex clasp brake, and the Atlas safety guards.

WOOD MILLER.—In a well-illustrated, four-page folder, the Oliver Machinery Company, Grand Rapids, Mich., describes its No. 75 wood milling machine. Its application to all kinds of pattern work, including gear patterns, is plainly shown in the folder.

SUPERHEATER DAMPERS.—The Locomotive Superheater Company, 300 Church street, New York, has recently issued Bulletin No. 3 on superheater dampers. The proper methods of installing, operating and maintaining the dampers are plainly illustrated and described.

WROUGHT IRON PIPE.—A photomicrograph showing a section of pipe magnified 60 diameters is an interesting feature of a folder recently issued by the A. M. Byers Company, Pittsburgh, Pa. The reason for the rust resisting properties of wrought iron is clearly brought out, and records of installation of Byers pipes are cited in the folder.

PORTABLE ELEVATOR.—The New York Revolving Portable Elevator Company, Jersey City, N. J., has issued recently Bulletin No. 50, entitled *The Revolver*, describing their portable elevator or tiering machine which is used in storerooms and warehouses for the piling or stacking of goods. The bulletin is well illustrated and shows in considerable detail how the Revolver can be used for many different kinds of work.

RIVET CUTTER.—The Rice Manufacturing Company, Indianapolis, Ind., has just issued an attractive booklet describing the "Red Devil" rivet cutter. This booklet contains detailed and complete information regarding the rivet cutter manufactured by this company, and several illustrations show its actual operation in railroad shops. In the back of the booklet there are several tables of value for reference purposes to men working on steel cars.

MOTIVE POWER PROBLEM.—The Baldwin Locomotive Works in Record No. 90 has issued in booklet form the address of its president, Alba B. Johnson, before the annual convention of the Chamber of Commerce of the United States, at Chicago, April 11, entitled "The Problem of Motive Power Under the National Administration of Railroads." An abstract of Mr. Johnson's paper was published in the *Railway Mechanical Engineer* for May, on page 246.

THE LOCOMOTIVE FURNACE.—Bulletin No. 1 of the American Arch Company is a condensed treatise on combustion and the relation of locomotive furnace and boiler proportions to the efficiency of combustion and heat absorption in the locomotive boiler, prepared by J. T. Anthony. The text is illustrated with charts, diagrams and drawings and is based upon a thorough study of the available data bearing upon the subject. It should be in the hands of every locomotive designer.

INDUSTRIAL LIGHTING.—Scientific Industrial Illumination is the title of a 36-page, illustrated booklet recently issued by the Holophane Glass Company, 340 Madison avenue, New York City. The booklet is divided into four parts showing the need for correct lighting, the fundamental principles involved, and the various types of industrial lighting units manufactured by the Holophane Company. The fourth section of the catalogue contains several reference tables and general engineering data.

Railway Mechanical Engineer

Volume 92

August, 1918

No. 8

CONTENTS

EDITORIALS:

Have You an Objective?.....	433
Careless Switching and Its Effect on Car Repairs.....	433
Keep Up Betterment Work on Cars.....	434
Higher Sulphur and Phosphorus Limits for Steel.....	434
Railroad Conditions in Germany.....	433
The Steam Consumption of Auxiliaries.....	435
New Books.....	435

GENERAL:

First U. S. Standard Locomotive.....	436
Drafting Modern Locomotives.....	439
Rules for Delivery and Transfer of Locomotives.....	444
Schedule for the Application of Superheaters.....	444
N. & W. 267-Ton Locomotive.....	445
Coal Gate Holders.....	450

CAR DEPARTMENT:

Reclaiming Car Axles.....	451
Steel Car Sill Straightener.....	452
Road Tests of the A. S. A. Brake.....	453
Gun Transport Car for the Navy.....	457
Instructions Relating to Car Repairs.....	459
Cutting the Cost of Exterior Car Cleaning.....	460
Efficiency in the Car Department.....	461

SHOP PRACTICE:

Main and Side Rods.....	463
The Shortage of Tin.....	464
Definitions of Terms Used in Air Compressor Rating.....	464
Roll Manufacture in Railway Shops.....	465
Another Wage Increase for Mechanical Department Employees.....	470
Prevention of Waste vs. Reclamation of Scrap.....	470
Maintenance of Cross-Compound Compressors.....	471
Welding Methods at Columbus Shops.....	473
A Crosshead Facing Tool.....	474

NEW DEVICES:

Motor Head Speed Lathe.....	475
Three-Wheel Tractor.....	475
New Idea Vise.....	476
Draft Recording Device.....	476
Glass Lubricating Cup.....	477
Pressure Governor for Gas and Liquid Systems.....	477
Newton Rail Drilling Machine.....	478
Inserted Cutter Tools.....	479
Jiffy Adjustable Cutter.....	479

GENERAL NEWS:

Notes.....	480
Meetings and Conventions.....	482
Personal Mention.....	482
Supply Trade Notes.....	485
Catalogues.....	486

Have You an Objective?

The successful commander invariably selects an objective, then coordinates the forces at his disposal to attain it. So, in the winning of the war, our boys overseas (and in camp "over here") are part of a vast plan in which each of them is subject to rigid discipline, physical and moral. They are rationed in food and clothing and restricted to specified activities. We who stay at home are just as much a part of the forces on which our leaders rely and we must place ourselves under discipline, self-imposed, but no less rigid, so that each of us shall do all that we can to realize the final objective—not alone the winning of the war, but veritably making this world a fit place for free men to live.

Laudable efforts to economize, as a nation, in smaller groups and as individuals have oft-times resulted in "saving at the lung, wasting at the spigot," due to lack of co-ordination of forces. The first phase of our thrift campaign, with its sales of War Savings Stamps, and various food and fuel restrictive measures has given results not to be despised. But we can do more and must, put our whole soul into the fight. Our armies need the best equipment that can be given them, and there being a scarcity of certain food-stuffs, materials, etc., it is our part of the fight to deny ourselves, so that those bearing the brunt of the battle may not fail because of our self-indulgence.

It is obvious that, while the ultimate objective of all is identical, the methods used to attain it must vary with our pursuits and station in life. Let each of us carefully appraise ourselves, select our immediate objective in the campaign of economy, take our place in the home battle line

and do our duty in a way worthy of our heritage. To do this is our high privilege, to do less is treason.

Have an objective; strive to attain it!

Careless Switching and Its Effect on Car Repairs

The Southern regional director in a letter to the roads in his section states that reports to his office for the week ending May 4 show 7,625 cars damaged in yard switching service, while for the week ending June 1, the number had increased to 15,625. Observation indicates that much of this damage is needless. On the other hand the situation is difficult to control without carrying on an aggressive campaign of education so that each individual involved will be impressed with the necessity for using greater care and will fully realize his importance, as an individual, in the campaign to improve conditions.

The seriousness of the situation becomes apparent when this damage is translated into terms of the number of car repairmen that are required to remedy it. It is becoming more and more difficult to maintain the car repair forces and a determined effort must be made to reduce the damage to a minimum. It never was justified and is much less so in the present emergency. A sardonic grin would surely spread over the Kaiser's visage if he could see the contempt which some trainmen have for taking reasonable care of the equipment entrusted to their charge. The situation is all the worse when the damage to the lading is added to the cost of repairing the cars and the needless delays and loss in use of equipment. There are times when thoughtlessness or indifference can be overlooked, but today in the transportation

service it is a *crime*. Never were railway men better paid—even taking into consideration the increased cost of living; never were those in authority so solicitous as to the hours of service and comforts and conveniences of the employees; never was it so essential that each railway employee do his duty fully, carefully, thoroughly and cheerfully. What would happen if the boys on the other side performed their tasks in the spirit of some of those who are engaged in occupations in this country which are essential to our success in carrying on the war?

**Keep up
Betterment
Work on Cars**

The routing of cars irrespective of ownership has resulted in a marked increase in the number of cars off the tracks of the owning road and a corresponding increase in the number of cars of other roads that are undergoing repairs in car shops all over the country. This has caused considerable difficulty in keeping up the repairs to the equipment. While such trouble will be lessened somewhat now that the roads are permitted to use non-standard material wherever necessary to keep cars in service, this does not dispose of the important question of preventing wasteful repairing of weak parts. There are many obsolete cars now in service which the roads have planned to reinforce; the percentage on the home roads, however, is so small that the work is seriously hampered. It is impracticable to attempt to have foreign lines apply betterments to cars, so the weak parts are continued in service and replaced at frequent intervals.

It is important that the practice of repairing in kind parts of inadequate strength should be stopped, as it is a waste of both labor and material. Cars with short draft timbers especially should be reinforced. In planning the work the roads should take account of the small number of cars that are on the tracks of the owning line, and instead of trying to reinforce all the cars of a single class should plan to handle some of the cars in all classes that need strengthening. It is the usual policy to carry on betterment work at only a few of the larger shops. The application of metal draft arms does not demand special equipment, and this and other reinforcing work should be carried on at all points where it can be handled, in order that the maximum possible number of cars may be equipped. It would afford partial relief from the present conditions if the roads would arrange that whenever possible cars with short draft timbers should be sent under load to the owning line or a direct connection. If the car supply improves materially after the delivery of the equipment now on order it might even prove advisable to have such cars sent to the owning line empty.

**Higher Sulphur
and Phosphorus
Limits for Steel**

For several years the standard specifications for chemical analysis of steel products have remained practically unchanged. Conditions in the steel industry are now so critical that the allowable maximum contents of sulphur and phosphorus in many materials are being increased. For several months the steel manufacturers have experienced difficulty in complying with the chemical requirements of existing specifications due to the low grade of fuel available and the inability to obtain ore low in phosphorus. Under these conditions it was necessary to change the specifications or reduce the output of the mills. With steel in great demand, a decrease in the production would be very undesirable. Manufacturers have contended that slight increases in the sulphur and phosphorus content would not impair the physical properties of the steel and laboratory tests confirm this opinion.

In these circumstances, it seemed best to change the chemical requirements. The M. C. B. Committee on Specifica-

tions and Tests for Materials has already revised the specifications for structural steel, steel plate and steel sheets for passenger and freight cars, increasing the maximum permissible sulphur content from .05 to .06 per cent. The principal effect of sulphur in steel is to reduce the strength at high temperatures, and as these parts are usually worked cold the higher proportion does not seem objectionable.

It is probable that the specifications for other steel products used by the railroad will be changed also. The American Society for Testing Materials, which includes in its membership many representatives of the roads, has recommended that the sulphur limit on all steel and the phosphorus limit on acid steel be raised by .01 per cent in about forty specifications. Among the materials included are structural steel, bar steel for springs, carbon steel and alloy steel forgings, wrought steel wheels and tires, steel castings, boiler tubes and locomotive axles. Exceptions have been made in cases where the change might prove detrimental; for instance, the allowable sulphur content for car axles has not been increased and no revision was made in the chemical requirements for locomotive firebox, boiler, or boiler rivet steel.

The intent of the changes in these specifications is not to permit the manufacturers to include greater amounts of impurities in steel products, but rather to reduce the percentage of rejected materials during the war. Arrangements have been made for keeping a record of the service secured from material bought under the revised specifications. These statistics will serve to show whether the higher sulphur and phosphorus contents prove detrimental to the material under actual service conditions and should furnish valuable information on which to base future specifications.

**Railroad
Conditions in
Germany**

The condition of the railroads in Germany has a direct effect on the military strength of the country and for that reason is of considerable importance to the United States and her Allies. Of the many conflicting accounts reaching us from the Central Powers it is hard to judge which are true and which are false reports disseminated for the purpose of creating the impression that Germany is on the verge of a breakdown and thus slowing up the military program of the Allies.

This country has seen the tremendous burden which war puts on the transportation system. Undoubtedly the German railroads have their troubles as well. We hear that there is difficulty in getting enough coal, that the supply of skilled labor is inadequate and that locomotives and cars cannot be kept in repair. The allied airmen have added to these troubles by frequently dropping bombs on important railroad centers. It seems quite certain that these difficulties really exist. However, the majority of people find it very easy to believe reports which picture conditions as they desire them to be, and it is highly probable that many of the reports of a breakdown of the German railways that have been circulated in this country are part of the German propaganda. Consider, for example, the reports published repeatedly during the past two years that the proper lubricants for railroad equipment could not be secured in Germany, and as a result locomotives needed frequent heavy repairs and train delays were greatly increased due to the prevalence of hotboxes. According to the testimony of Americans who were in Germany up to the time when this country entered the war, the shortage of lubricants at that time had scarcely affected even the non-essential industries. It is improbable that such plants would be allowed to use any oil if the railroads were not assured of an ample supply. Since then the Germans have had an opportunity to rebuild the refining plants in the Roumanian oil fields, yet reports of the shortage of lubricants continue.

There are many indications that German rolling stock is not in such bad condition as has been represented. While no operating statistics are available we know that the receipts of the German railways for the first nine months of 1917 exceeded those for the corresponding period of 1916 by 30 per cent on passenger traffic and 5 per cent on freight. Before the war Germany did a large export business in railroad supplies of all kinds, and that the plants she possesses are capable of taking care of the requirements of the German railway system seems evident from the fact that the Germans are now building two railways in Finland and have started deliveries on 30 locomotives and a considerable tonnage of rails ordered by the railroads of Sweden. The only logical conclusion that can be drawn from these facts is that there is little prospect of a breakdown of the German industrial system. We must win by force of arms. Every railroad man in this country should realize that by doing his work well he will help to speed the day of victory for the United States and her Allies.

The Steam Consumption of Auxiliaries

Few railroad men realize the large proportion of steam generated on a locomotive that is used by the auxiliaries. In freight service the steam supplied to the air compressor alone is often as much as ten per cent of that which goes to the cylinders. Add to this the steam used by the headlight and the blower and that wasted through the safety valve and by steam leaks at valve stems and piston rods and the total will amount to as much as fifteen per cent of the steam used in pulling the train. In passenger service the amount of steam used by the air compressor is not as great, proportionately, as in freight service, but during the winter the steam used to heat the cars brings the percentage used elsewhere than in the cylinders to a high figure, often over twenty per cent.

While great care is taken to prevent losses in the valves and cylinders, little attention is paid to the condition of the numerous devices on the locomotive that are constantly using steam. The air compressor is subjected to more abuse than any other machine of equal importance. Compressors with efficient strainers and proper lubricating devices are the exceptions rather than the rule. It is unreasonable to expect an appliance that is given so little attention to use steam economically. The safety valves are a part of the locomotive equipment that most railroad men consider should go from one shopping to another without attention. Very often such a record is made, but how much fuel is wasted through safety valves that start to leak five or ten pounds below the pressure for which they are set, or that when once open continue to blow out a small amount of steam until the pressure has fallen considerably below the point at which they should seat. Such defects should receive prompt attention, but there is always a tendency to regard them as scarcely worthy of notice.

To appreciate the effect of a saving in the steam used by the auxiliaries the resulting increase in hauling capacity should be considered. Only fifty to sixty-five per cent of the power developed in the cylinders is delivered at the drawbar under ordinary conditions. Thus, if the steam saved by these minor economies amounts to five per cent of that used by the cylinders, instead of adding five per cent to the hauling capacity it will increase the capacity nearly ten per cent. Similarly if the saving is not utilized in hauling greater tonnage it will reduce the amount of coal burned and lower the rate of combustion, and this in turn will decrease the coal consumption per pound of water evaporated, resulting in cumulative savings.

The importance of economy in the use of fuel has been emphasized during the past year as it never has been before. No saving is too great to strive for and none too small to

deserve consideration. A great deal of attention is being paid to the economical generation of steam in the boiler and its utilization in the cylinders, and rightly so. It is here, beyond a doubt, that the greatest field for economy lies. However, the steam consumed by the auxiliaries is by no means a negligible amount and it should also be given its share of attention.

NEW BOOKS

Fuel Economy in the Operation of Hand Fired Power Plants. Edited by the research staff of the Engineering Experiment Station of the University of Illinois. Illustrated, 90 pages, 6 in. by 9 in. Bound in paper. Published by the Engineering Experiment Station of the University of Illinois, Urbana, Ill.

The average small power plant is an inefficient unit and can save 15 per cent of its fuel by the exercise of greater care in equipment and operation. To show how this is possible the Engineering Experiment Station of the University of Illinois has issued Circular No. 7, entitled *Fuel Economy in the Operation of Hand Fired Power Plants*. It presents to managers, superintendents, engineers and firemen suggestions that will help them in determining the properties and characteristics of the coal purchased and in effecting greater economy in its use. The features of installation essential to the proper combustion of fuel are discussed, the practice to be observed in the operation of the plant is outlined, and the employment of simple devices for indicating conditions of operation is described. A limited supply of copies of this publication is available for free distribution.

The Cost of Power. By Gerald B. Gould, M.A., and Carleton W. Hubbard, B.S. 125 pages, 4½ in. by 6½ in., illustrated, bound in leather, published by the Fuel Engineering Company of New York. Price \$2.

This manual was originally written for private distribution among about 200 manufacturers and is the result of their co-operative efforts to eliminate guesswork methods in the selection and purchase of coal, and the development of power. By comparing the combined experience of these coal users in the purchase and use of nearly \$50,000,000 worth of coal, the attempt is made to reduce the problem to basic principles. All of the plans and theories advanced have been tested in actual use, and each fact given has been verified by a large number of observations. In the form presented the book has been planned to fill the need of business men who have not had an opportunity to study the broader aspects of heat and power problems; its object is to supplement the reader's knowledge with a detailed analysis of the experience of many users of coal and makers of power.

Proceedings of the International Railway General Foremen's Association. 104 pages, illustrated, 6 in. by 9 in., bound in paper. Published by the association, William Hall, secretary, 1061 West Wabash avenue, Winona, Minn.

Although the General Foremen's Association held no convention in 1917, a successful effort was made to give the members of the association as much benefit from the organization as possible. The pre-determined papers and reports were written and advance copies were sent to the members. The official proceedings contains these papers, together with many written discussions on them submitted by various members of the association. The important subjects discussed include Engine Failures, Causes and Responsibilities, Methods of Meeting the Requirements of Federal Inspection Laws, Alignment of Locomotive Parts to Give Maximum Service with Minimum Wear, and What Interest Has the Locomotive Foreman with Car Department Matters.

The association is to be congratulated upon the fact that even though no convention was held, the members of the association have received something that will be of assistance to them in their work.

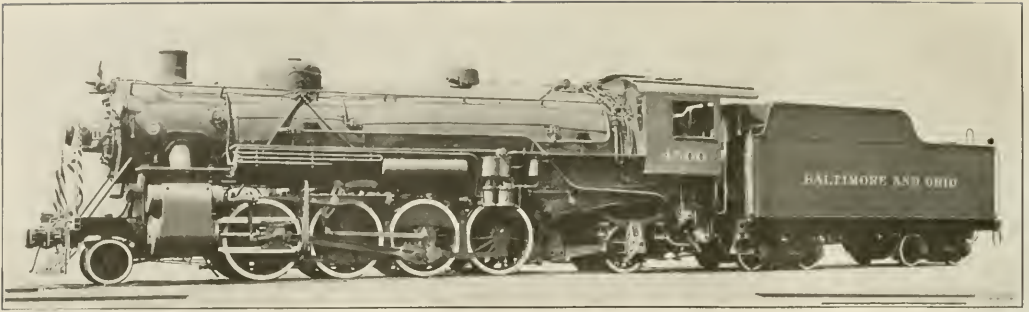

First Standard Locomotive to Be Completed for the Railroad Administration

FIRST U. S. STANDARD LOCOMOTIVE

Light Mikado Type Built by the Baldwin Locomotive Works, in Service on the Baltimore & Ohio

THE first locomotive of the Railroad Administration's order of standard locomotives placed with the builders on April 30, was completed on July 1, by the Baldwin Locomotive Works. This locomotive is of the light Mikado type, the specifications for which call for 55,000-lb. driving axle loads, and has been placed in service on the Baltimore & Ohio.

The orders for standard locomotives first placed by the Railroad Administration totaled 1,025. Later orders for 390 locomotives brought the total up to 1,415, of which 575 are light Mikados. This is by far the largest number of any

dome is extended to form the inside welt strip of this seam. The longitudinal seams of the conical and front courses are at the right and on the top center line of the boiler, respectively. These seams are all welded at the ends.

On the basis of Cole's ratios, the boiler capacity rating is practically 96 per cent of the cylinder requirements in respect to the heating surfaces, and slightly over 100 per cent in respect to the grate area. The tubes are $2\frac{1}{4}$ in. in diameter and 19 ft. long over the tube sheet, the ratio of the diameter to the length of tubes being about one to 100. The firebox includes a combustion chamber 24 in. long and is

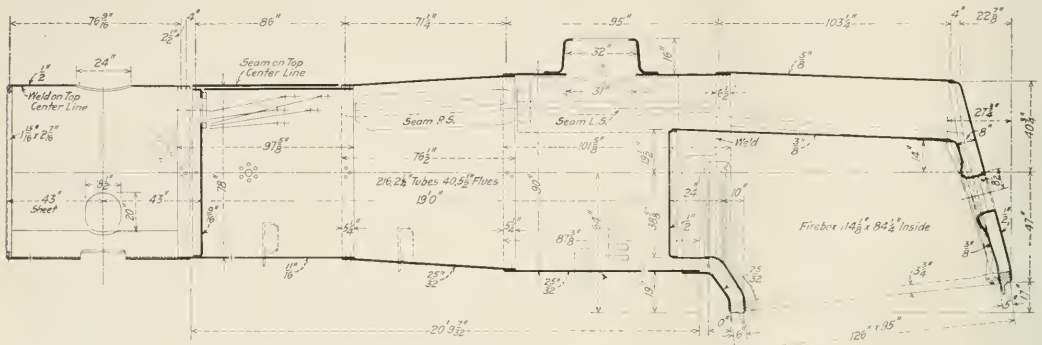

Boiler of the Railroad Administration Standard Light Mikado Type Locomotive

type ordered; the next largest group is the heavy Mikado type, of which 157 are to be built.

The design of the light Mikado type locomotive is straightforward throughout, with nothing of an unusual nature either in the general design or the details of construction. The locomotive has a total weight of 290,800 lb., of which 221,500 lb. are on the drivers, and it exerts a starting tractive effort of 54,600 lb.

The boiler is of the conical wagon top type, 78 in. in diameter over the first course and increasing to 90 in. in outside diameter at the dome course. The longitudinal seam of the dome course is on the left hand side of the center line, and the reinforcing pad on the inside of the shell under the

fitted with a Security arch. The boiler includes the Locomotive Superheater Company's Type A superheater with 40 units and is fired by a Duplex stoker. It is fitted with a Shoemaker fire-door.

The ash pan has three center hoppers with swinging drop bottoms. The opening under the mud ring is $5\frac{1}{2}$ in. wide. The grates are operated by a Franklin grate shaker.

The frames are of cast steel, 6 in. wide, with a single integral front rail. The top rail is $6\frac{5}{8}$ in. deep over the pedestal and is $5\frac{5}{8}$ in. deep at the smallest section. The depth of the lower rails at the smallest section is 4 in. The taper of the pedestal jaws and binder lugs is one in twelve. The front rail under the cylinders is $9\frac{7}{8}$ in. deep and the

section is reduced to 3½ in. wide by 10 in. deep where the front deck plate is attached. The trailer frames are cast in one piece with the trailer fulcrum pin bracket, the equalizer brackets and the rear deck plate. This casting is attached to the main frames with fourteen 1¼-in. bolts on each side. The pedestal binders are of the usual type, each held in place by four 1½-in. bolts.

Vertical cast steel frame cross-ties are applied to the front legs of the forward driving-wheel pedestals and to the rear legs of the second and third pedestals. The forward brace includes an extension at the bottom, which is bolted to the lower frame rails just behind the cylinders. This carries the pivot for the front engine truck and the driving brake lever fulcrums. The top rails are further secured by cast-steel deck braces, which extend across the frames between the first and second, and the third and fourth pairs of driving wheels.

The cylinders and valve chambers are fitted with gun-iron bushings. The pistons are steel of single plate dished section. The piston valves are of the built up type, with a cast-iron body, fitted with gun-iron bull rings and packing rings and cast-steel followers. King type packing is used in the piston rod and valve stem glands. The cross-heads have cast-steel bodies, to which are bolted Hunt-Spiller gun-iron wearing shoes. Steam distribution is controlled by the

5/16 in. in thickness, while the sides and ends are ¼ in. thick. The tank manhole is 18 in. wide by 8 ft. in length across the tank. This great length materially facilitates spotting of the locomotive at water plugs.

The tender is carried on four-wheel trucks with cast-steel side frames and bolsters fitted with elliptic springs. The wheels are rolled steel, 33 in. in diameter and are mounted on axles having 6-in. by 11-in. journals.

The specialties include Everlasting blow-off valves, 2-in. Consolidated safety valves, Ashcroft gages, 1¼-in. Barco blower valve fitting, Nathan non-lifting injectors, Franklin ball joints and Radial buffer and Unit safety bar between the engine and tender.

The principal data and dimensions follow:

General Data

Gage	4 ft. 8½ in.
Service	Freight
Fuel	Bit. coal
Tractive effort	54,600 lb.
Weight in working order	220,800 lb.
Weight on drivers	221,500 lb.
Weight on leading truck	20,200 lb.
Weight on trailing truck	49,100 lb.
Weight of engine and tender in working order, approx.	462,800 lb.
Wheel base, driving	16 ft. 9 in.
Wheel base, total	36 ft. 1 in.
Wheel base, engine and tender	71 ft. 4½ in.

Ratios

Weight on drivers ÷ tractive effort	4.0
Total weight ÷ tractive effort	5.3
Tractive effort × diam. drivers ÷ equivalent heating surface*	730.9
Equivalent heating surface* ÷ grate area	70.6
Firebox heating surface ÷ equivalent heating surface*, per cent.	11½
Weight on drivers ÷ equivalent heating surface*	47.0
Total weight ÷ equivalent heating surface*	61.8
Volume both cylinders	18.4 cu. ft.
Equivalent heating surface ÷ vol. cylinders	255.3
Grate area ÷ vol. cylinders	3.6

Cylinders

Kind	Simple
Diameter and stroke	26 in. by 30 in.

Valves

Kind	Piston
Diameter	14 in.
Greatest travel	7 in.
Steam lap	1½ in.
Exhaust clearance	0 in.
Lead	3/16 in.

Wheels

Driving, diameter over tires	63 in.
Driving, thickness of tires	3½ in.
Driving journals, main, diameter and length	11 in. by 13 in.
Driving journals, others, diameter and length	10 in. by 13 in.
Engine truck wheels, diameter	33 in.
Engine truck, journals	6½ in. by 12 in.
Trailing truck wheels, diameter	43 in.
Trailing truck, journals	9 in. by 14 in.

Boiler

Style	Conical wagon-top
Working pressure	200 lb. per sq. in.
Outside diameter of first ring	78 in.
Firebox, length and width	114½ in. by 84½ in.
Firebox plates, thickness	Tube, ¼ in. crown, sides and back, ¾ in.
Firebox, water space	Front, 6 in.; sides and back, 5 in.
Tubes, number and outside diameter	216-2¼ in.
Fires, number and outside diameter	40-5½ in.
Tubes and flues, length	19 ft.
Heating surface, tubes and flues	3,497 sq. ft.
Heating surface, firebox, including arch tubes	286 sq. ft.
Heating surface, total	3,783 sq. ft.
Superheater heating surface	882 sq. ft.
Equivalent heating surface*	4,706 sq. ft.
Grate area	66.7 sq. ft.

Tender

Tank	Water bottom
Frame	Cast steel
Weight, approximate	172,000 lb.
Wheels, diameter	33 in.
Journals, diameter and length	6 in. by 11 in.
Water capacity	10,000 gal.
Coal capacity	16 tons

* Equivalent heating surface = total evaporative heating surface + 1.5 times the superheating surface.

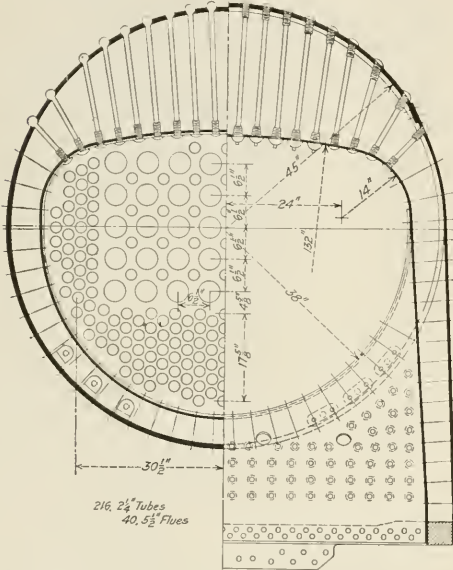

Sections Through the Firebox and Combustion Chamber

Walschaert valve gear, to which is fitted a Ragonnet power reverse gear.

Cast-steel driving boxes, fitted with Elvin grease cellars, are used throughout, all having journal bearings 13 in. in length. The journals on the main axle are 11 in. in diameter, while the others are 10 in. in diameter. The driving wheels are fitted with brass hub liners.

The leading truck is of the Economy constant resistance type and the Hodges trailing truck is used.

The tender has a Commonwealth steel frame. The frame casting includes the front drawbar pocket and the rear draft sills, as well as the truck center plates. The tank is of the usual type of construction, the corners being formed by 2½-in. by 2½-in. angles. The bottom and top plates are

ELECTRIC LOCOMOTIVES BUILT IN SOUTH MANCHURIA.— The 50-ton electric locomotives for use by the Fushun collieries are the first built at the South Manchuria Railroad shops. They are of standard gage. Each is designed to haul 580-ton trains at a speed of 12.9 miles per hour, on the level, straight track, exclusive of the locomotive. The trolley voltage is 1,200. They are of the two-bogie type, each bogie carrying a 125-hp. motor.

DRAFTING MODERN LOCOMOTIVES

N. & W. Tests; a Comparison of the Best Results with the Various Nozzle and Stack Arrangements

BY H. W. CODDINGTON

Engineer of Tests, Norfolk & Western, Roanoke, Va.

PART III*

THE results obtained from the annular nozzles constructed on a 14-in. diameter circle led to still further developments, and an annular nozzle conforming to a 16-in. diameter circle was designed, as the results with the nozzles constructed on a 14-in. diameter circle did not indicate that any limiting conditions in diameter had been reached. This nozzle, which is designated as waffle iron nozzle, style A-5, is shown as Fig. 14. It was tested out in runs No. 54-55 with a 22-in. diameter stack and a 26½-in. inside extension. In this size of stack, the exhaust column missed the stack at the top by an average distance of 3/16 in., though closely

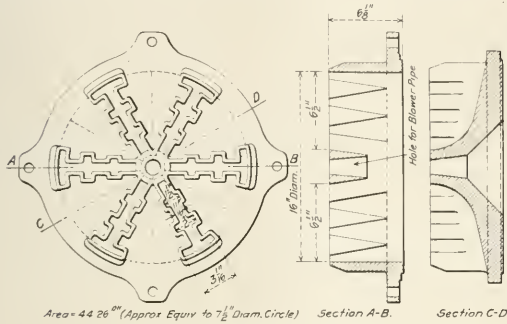

Fig. 14—Waffle Iron Nozzle A-5

hugging the walls of the stack for the upper half of its passage. The exhaust stack diagram for this combination is shown in Fig. 15. The draft conditions were not nearly so favorable as those obtained from either waffle iron nozzle, style A-3, or plain annular nozzle, style A-4a, and the draft efficiency of 0.040 was much lower. This nozzle was later tried with a 20-in. diameter stack in runs No. 64-65. While the exhaust filled the stack at an average distance from the top of 42 7/8 in., no improvement in draft condition was observed. The draft efficiency was identical with that obtained from the same nozzle when used with a 22-in. diameter stack. The exhaust stack diagram for this nozzle with the 20-in. stack, is shown in Fig. 16.

In a further effort to find the proper stack to combine with nozzle style A-5, a 26-in. diameter stack with a 26½-in. inside extension was applied. This combination was tested out in runs No. 47-49 and while no better draft conditions were obtained, there was a slight reduction in exhaust pressure which resulted in increasing the draft efficiency to 0.045. The average speed of these runs was slightly below normal, which may have been an influencing factor in reducing the exhaust pressure and consequently improving the item of draft efficiency. The exhaust stack diagram for the combination used in runs No. 47-49 is shown in Fig. 17. With this combination, it will be noticed that the exhaust was clearing the stack, entirely missing it

at the top by an average distance of 2 1/4 in. for the two runs.

A plain annular nozzle was constructed, designed on the lines of a 16-in. circle and conforming to waffle iron nozzle style A-5, except for the shape of the ports. In the style A-5 nozzle, the total length of the exhaust ports was 6 1/2 in., while in the style A-6 nozzle the length was 5 1/2 in. The latter nozzle is shown in Fig. 18. It was tried with three different sizes of stacks. Run No. 66 was made with in Fig. 16. Runs No. 52-53 were made with a 22-in. stack. This resulted in some improvement in the draft production a 20-in. stack with no indication of increased draft or efficiency. The exhaust stack diagram for this run is shown as well as a slight improvement in the draft efficiency, which was 0.042. The exhaust stack diagram, Fig. 15, shows that the exhaust was missing the stack entirely and cleared it at the top by an average distance of 2 1/16 in. A 26-in. stack was applied for runs No. 50-51. The draft was not as high as that produced with the 22-in. stack, although the draft efficiency was 0.001 higher due to a slight reduction in exhaust pressure. By referring to Fig. 17 it will be observed that the exhaust for these runs was clearing the

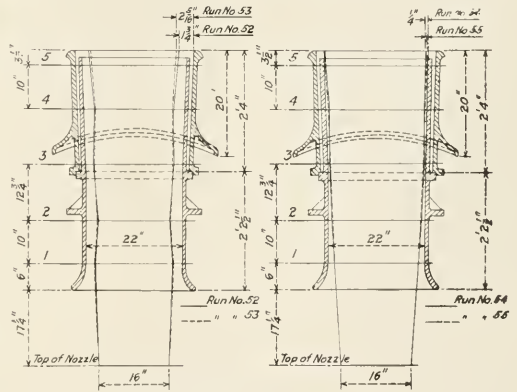

Fig. 15—Exhaust Stack Diagrams for Runs 52, 53, 54 and 55

stack and missing it at the top by an average distance of 4 7/8 in. These results appear to contradict what has been observed in previous combinations; i. e., that a better draft condition is produced when the jet strikes well down in the stack. The latter condition prevailed, however, within the range of possible improvement in draft performance and may be considered as a law which obtains within that range, although it does not appear to apply strictly to the combinations when nozzles constructed upon a 16-in. diameter circle were used.

In comparing the results obtained from waffle iron nozzle style A-5 and plain annular nozzle style A-6, it is noticed that the plain annular nozzle did not show as high a degree

*For preceding articles see *Railway Mechanical Engineer* for June, 1918, page 331, and July, 1918, page 327.

ing the exhaust jet to strike well down in the stack instead of passing out without coming in contact with the stack walls, as was the case when the nozzle A-5 was used in runs No. 47-49.

Nozzles style A-9 and style A-10, shown in Figs. 20 and

with those presented in Table III, there being included certain items which are necessary for a completion of the operating record, but to which attention need not be especially directed. It might be of interest to call attention to items No. 21, 22, and 23, which show the average vacuum

TABLE V—SUMMARY OF BEST RESULTS COMPARED WITH ORIGINAL ARRANGEMENT

Run No.	Stack		Nozzle			Area 6	Speed, M. P. H.	Pressure, lb. per sq. in.		Draft, in. water			† Exhaust jet striking, in. from top of stk.
	Diam., in.	Length inside exten., in.	Act'l or equiv. diam., in.	Style and diam. of bridge	Boiler 8			Exhaust 9	Front end 10	Back of baffle 11	Firebox 12	† Draft efficiency 13	
1	18	26 1/2	7	S 3/8	35.86	27.6	189.4	11.44	8.60	7.01	1.26	.027	4 3/16
17	18	26 1/2	7	S 3/8	35.86	33.0	192.5	10.94	8.91	7.25	1.32	.029	— 1 1/2
5	18	26 1/2	7 1/2	S none	44.18	25.7	170.0	6.50	6.10	4.97	1.34	.034	2 1/4
41-42*	24	26 1/2	7 1/2	A-3	44.32	32.1	198.1	7.57	11.52	9.51	1.57	.055	35 7/16
72-73*	24	26 1/2	7 1/2	A-4a	44.23	32.0	200.1	9.00	12.29	10.50	2.04	.051	35 3/8
2	18	26 1/2	8	S 3/8	47.26	29.0	185.9	6.44	7.36	5.98	1.58	.041	2 11/16
70	24	26 1/2	7 3/8	A-3	45.79	31.4	200.8	6.61	10.39	8.54	1.97	.057	39 3/4
21*	24	26 1/2	7 3/8	A-3	45.79	30.6	199.3	5.96	9.54	7.83	1.24	.058	39 3/4
74*	24	26 1/2	7 15 16	A-4b	49.35	29.5	200.2	4.54	8.63	6.94	1.31	.068	2 1/4

* Flare of stack increased on these runs.
 † Draft efficiency equals draft in pounds divided by exhaust pressure.
 ‡ Exhaust missing the top of the stack is indicated by negative values.

TABLE VI—SUMMARY OF BEST RESULTS AS COMPARED WITH ORIGINAL ARRANGEMENT

Run No.	Running time, hrs.	Train			Per cent total draft required			Vacuum between nozzle ports, in. water (see Fig. 18)			Water		Equiv. evap. per sq. ft. h. s. per hr.
		No. cars	Tons		Under diaphragm	Through tubes	Through fire	A 21	B 22	C 23	Pounds 24	Temp., deg. F. 25	
1	15	16	623.7	17	18.5	66.9	14.6	21,925	57.0	13.69
17	.40	9	600.5	18	18.6	66.6	14.8
5	.57	16	618.2	18	18.5	59.5	22.0
41-42	.42	14	629.7	17	17.4	69.0	13.6	18.71	18.33	16.63	23,125	64.0	13.50
72-73	.40	14	635.2	17	17.8	66.2	16.0	20.08	20.76	19.69	20,963	69.3	12.96
2	.47	16	618.2	18	18.7	59.8	21.5
70	.41	14	635.2	17	17.8	63.2	19.0	15.72	17.27	20,775	69.0	12.53
71	.40	14	635.2	17	17.9	69.1	13.0	14.16	14.55	20,350	68.5	12.58
74	.45	14	635.2	19	19.6	65.2	15.2	9.70	9.89	10.09	22,175	69.0	12.76

21, respectively, were constructed on the lines of a 16-in. circle but have an area equivalent to the area of a 7 3/4-in. circle. Nozzle style A-9 is of plain annular type, while style A-10 is of the waffle iron type. Both of these nozzles

observed at the different points between the annular exhaust ports. These readings conclusively demonstrate that there is an active entraining action between the annular exhaust ports, which confirms the original conception of the influence that might be produced by constructing an exhaust nozzle with widely-separated annular ports.

In a review of the results of Table III, it might be stated that, while different types of nozzles and sizes of stacks entered into the various tests, it was observed that the best results were obtained by the use of waffle iron nozzle style A-3, the area of which is equivalent to a 7 1/2-in. circle, used with a 24-in. diameter stack. This nozzle was constructed on a 14-in. circle and corresponded in dimensions and style to the nozzle shown in Fig. 10. Considerable time and expense were expended in an effort to improve upon the results obtained

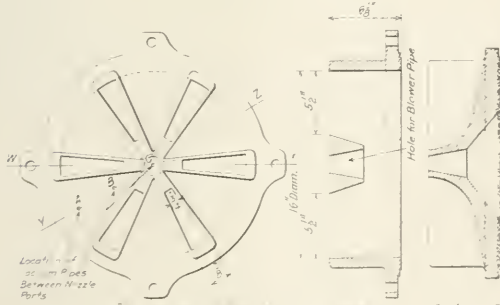

Fig. 18—Plain Annular Nozzle A-6, Showing Location of Vacuum Gages Between the Ports

were tried with a 26-in. stack and a 26 1/2-in. inside extension. Style A-9 was tested out in runs No. 58-59-60, from which an average draft of 7.87 in. of water was obtained with a draft efficiency of 0.046. Style A-10 was used in runs No. 61-62, from which an average draft of 7.65 in. of water was obtained with a draft efficiency of 0.051. The improvement in draft efficiency with the waffle iron nozzle was due to a lower exhaust pressure. The exhaust stack diagrams for these two nozzles are shown in Fig. 22. It will be observed from these diagrams that, under both conditions, the exhausts are missing the stack, yet there is a closer conformity to the stack with the waffle iron style A-10 nozzle than there is with the plain annular nozzle style A-9.

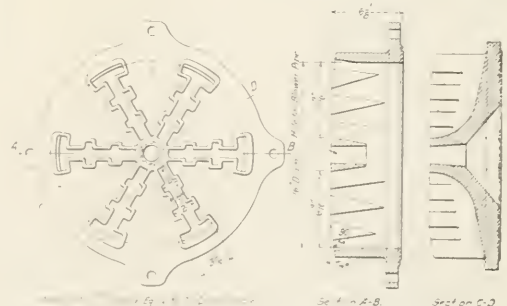

Fig. 19—Waffle Iron Nozzle A-8

from this combination by different shapes and dimensions of nozzles but without any satisfactory results. It was found in the use of nozzles constructed upon a 16-in. diameter circle that not only was there no improvement indicated over previous designs, but the results did not compare with those

In Table IV are shown data which may be considered

already established by the nozzles built on a 14-in. diameter circle.

BEST RESULTS COMPARED WITH RESULTS WITH ORIGINAL ARRANGEMENT

Tables V and VI have been prepared to present a summary of the best results obtained with the different nozzles as compared with those obtained with the locomotive operating in its original condition. The results of runs No. 1 and 17 show the performance of the standard arrangement using a 7-in. diameter nozzle with a 3/8-in. bridge and an 18-in. stack from which it is observed that the average exhaust pressure was 11.19 lb. per sq. in. and the average draft 8.75 in. of water. The average draft efficiency therefore was 0.028.

Run No. 5 shows the results of a standard 7 1/2-in. diameter nozzle without a bridge. The exhaust pressure in this combination was reduced to 6.5 lb., but the front end draft was also reduced to 6.10 in. of water. It will be observed that the average boiler pressure, as well as the speed, were very low, which would place the results of this run on a basis that would not be wholly comparable with the others shown.

Runs No. 41-42 were obtained by the use of waffle iron nozzle style A-3, corresponding in area to a 7 1/2-in. diameter circle and operating with a 24-in. diameter stack with 26 1/2-in. inside extension. The results from this combination were very satisfactory, producing a draft of 11.52 in. of water with an exhaust pressure of only 7.57 lb., resulting in a draft efficiency amounting to 0.055.

Runs No. 72-73 were made with the same stack conditions and the same size nozzle as runs No. 41-42, except that the shape of the nozzle was changed from the waffle iron style to the plain annular style. With this combination, it will be observed that a draft of 12.79 in. of water was obtained but was accompanied by exhaust pressure of 9 lb., resulting in a draft efficiency of 0.051.

In run No. 2, the locomotive was equipped with a standard type of nozzle, 8 in. in diameter, provided with a 3/8-in. diameter bridge. This type of nozzle was used in con-

junction with an 18-in. diameter stack which the exhaust did not fill until near the top. A draft condition was obtained from this combination which was too low to be satisfactory for general service conditions, and led to the further conclusion that little opportunity for improvement in draft results was possible without changing the standard front end equipment.

Run No. 70 and 71 were made with waffle iron nozzle style A-3, corresponding in area to a 7 3/8-in. diameter circle, used with a 24-in. diameter stack and a 26 1/2-in. inside extension. The only difference in these two runs was that in run No. 70 the stack had the standard flare of one inch

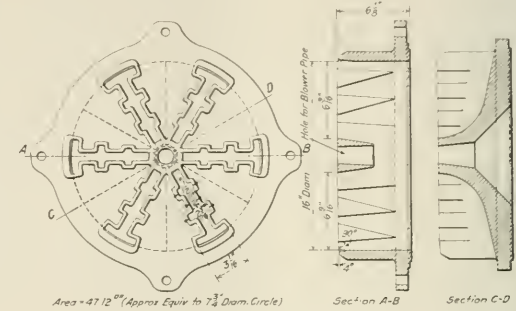

Fig. 21—Waffle Iron Nozzle A-10

of the nozzle, it is observed that the exhaust pressure was considerably reduced. In operating with this nozzle, a draft efficiency of 0.068 was secured. This is a very efficient combination if the condition of draft is sufficiently high to produce free steaming results. It is observed, however, that the draft of 8.63 in. of water is no better than 8.60 in. obtained in run No. 1 with the original standard arrangement, but the exhaust pressure of 4.54 lb. stands out in strong contrast with the exhaust pressure of 11.44 lb., which was a feature of run No. 1.

Table VI furnishes additional information relative to the conditions under which the tests were run, as well as some of the results obtained from these test runs, but as this table does not appear to suggest any lack of uniformity in operating conditions worthy of mention, it will be included in the published data without further comment.

The diagrams in Fig. 24 have been prepared to illustrate graphically the improvement that has been made in draft and exhaust pressure conditions, showing in contrast with the exhaust pressure and draft readings obtained from run No. 17 with the standard equipment, the exhaust pressure and draft readings from runs No. 41, 70 and 74. In the upper section of the diagram the exhaust pressures are plotted, while in the lower section the draft readings are presented. Both items have been plotted against speed in miles per hour. It was found in plotting these diagrams that straight lines appeared to represent the trend of the results within the range of speeds observed, which range was necessarily limited. These straight lines have been drawn through a mean point on the curve, which is representative of the average speed and the average exhaust pressure readings for the exhaust pressure diagrams, and of the average speed and the average draft readings for the draft diagrams.

The high exhaust pressure existing with the standard arrangement is shown by the high position of the exhaust pressure line for run No. 17. It will also be observed in the draft diagram that the results of run No. 17 took the

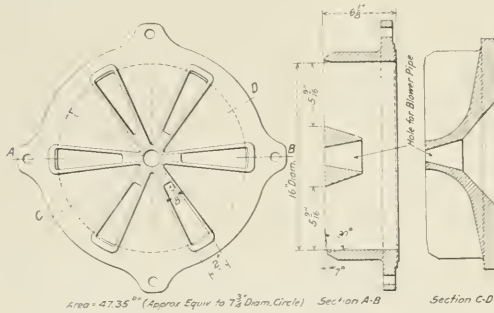

Fig. 20—Plain Annular Nozzle A-9

junction with an 18-in. diameter stack which the exhaust did not fill until near the top. A draft condition was obtained from this combination which was too low to be satisfactory for general service conditions, and led to the further conclusion that little opportunity for improvement in draft results was possible without changing the standard front end equipment.

Runs No. 70 and 71 were made with waffle iron nozzle style A-3, corresponding in area to a 7 3/8-in. diameter circle, used with a 24-in. diameter stack and a 26 1/2-in. inside extension. The only difference in these two runs was that in run No. 70 the stack had the standard flare of one inch

lowest position; hence it may be said that the standard front end arrangement produced a condition of maximum exhaust pressure and minimum draft. In run No. 41, the reduction in exhaust pressure is remarkable: at the same time the draft conditions have been materially improved. Run No. 70 illustrates a still lower exhaust pressure with draft conditions ranging between the results of runs No. 17 and 41, while run No. 74 shows a remarkably low exhaust pressure with a draft practically equal to that of run No. 17. A comparison of the lines for runs No. 17 and 74 shows impressively the appreciable improvement that has

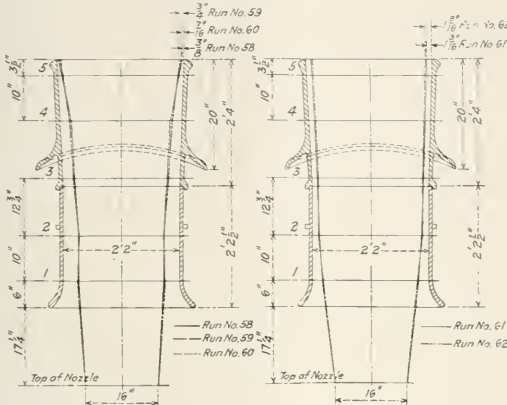

Fig. 22—Exhaust Stack Diagrams for Runs 58, 59, 60, 61 and 62

been accomplished in the reduction of exhaust pressure, while, at the same time, practically equal draft has been maintained.

From the data given in Table V, a selection of the proper front end combination to give the best results can conveniently be made. Operating with a nozzle equivalent to a 7 1/2-in. circle, it is observed that waffle iron nozzle A-3 used in runs No. 41-42 with a 24-in. diameter stack and a 26 1/2-in. inside extension, gave results sufficiently excellent to justify the recommendation of this combination as standard for mountain type class K1 locomotives. If the locomotive can be operated successfully with a lower draft, the waffle iron nozzle, style A-3, may be enlarged to correspond in area to a 7 5/8-in. diameter circle, as is illustrated in the results from runs No. 70 and 71; but if the locomotive can be operated successfully with a draft equal to that formerly obtained with the standard equipment, depending upon the reduction in exhaust pressure to improve the performance, it is found that nozzle style A-4b, corresponding in area to a 7-15/16-in. circle, as used in run No. 74 with the same stack combination, will give excellent efficiency results. It may be of interest to state that the first two combinations mentioned have been in service through the winter months without any complaint being registered against the steaming properties of the locomotives. There are now sixteen class K-1 locomotives equipped with the 24-in. stacks and waffle iron nozzles corresponding to either 7 1/2-in. or 7 5/8-in. area circles.

It will no doubt be both profitable as well as interesting to draw some deductions as to the effect of the reduction of exhaust pressure upon the performance of the locomotive. Considering again Table V and comparing the average results of runs No. 1 and 17 with the average results of runs No. 70 and 71, it is observed that an average reduction in exhaust pressure to the extent of 4.91 lb. per sq. in. has been obtained in the improved arrangement. This reduc-

tion is equivalent to the elimination of resistance in the cylinder to the amount of 139 hp. that is, the engine operating under the above-mentioned conditions is capable of developing 139 more horsepower than it was under the original conditions of operation. At the same time, the draft has been increased from 8.75 to 9.96 in. of water. The difference in the performance of the locomotive due to the change in front end arrangement is still more pronounced when applied to the results obtained with the style A-4b nozzle with area equivalent to 7-15/16-in. diameter circle, where a reduction in back pressure of 6.65 lb. per sq. in. was obtained. This is equivalent to a reduction in cylinder resistance of 188 hp. Under this condition, however, the draft has not been improved, in fact it is slightly lower, being 8.63 in. while the average of the two runs with the standard equipment was 8.75 in.

This reduction in exhaust pressure not only means an increase in the power of the locomotive, but it suggests a decrease in fuel consumption on the basis of equal work demanded. Assuming 5 1/2 lb. of coal per i. hp. hr., which is a conservative assumption, the locomotive equipped with the waffle iron nozzle, style A-3, working under the same load conditions as formerly, should consume 764 lb. less coal per hour, while the locomotive equipped with the style A-4b nozzle, working under the same conditions of load and speed as formerly should consume 1,034 lb. less coal per hour.

While no accurate account was taken of the coal consumption during the progress of the test, a quite perceptible difference in fuel consumption was observed after certain of the annular nozzles were applied. In runs with the standard front end arrangement it was not possible with a full tender of coal to run from Roanoke to Christiansburg, and then make two additional runs from Elliston to Christiansburg, but after the more efficient annular nozzles were

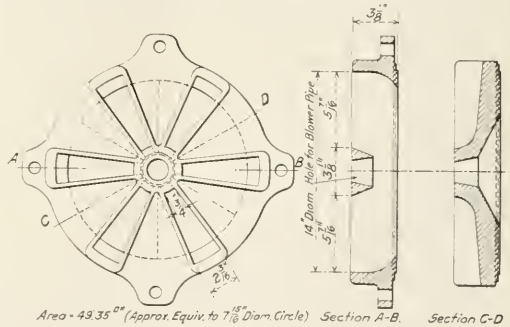

Fig. 23—Annular Nozzle A-4b

applied it was possible to run from Roanoke to Christiansburg and then make two, and sometimes even three, trips between Elliston and Christiansburg without securing additional fuel.

CONCLUSIONS.

The foregoing consideration of the data obtained from these tests leads to the following conclusions:

- (1)—Considering the original standard nozzle, it was found that slightly higher draft and draft efficiency were obtained by the use of a bridge. The only exception to this law was the comparison with the 9-in. inside stack extension, in which the draft efficiency was higher but the draft itself was reduced.
- (2)—In determining the proper length of inside extension for the stack and the proper location for the exhaust

column to strike the stack, it was shown that the best results were obtained with the long extension, which was 26½ in. long measured from the joint, or 35 in. measured from the smoke arch. Shortening the inside stack extension has the same effect upon the relationship of the exhaust column and the stack as increasing the size of the stack. It was further observed that the best draft conditions were obtained when the exhaust struck the walls of the stack at a distance from the top equal to 70 per cent of the total length of the stack.

(3)—It was further conclusively demonstrated that the possibility for improvement with the present standard type of nozzle was exceedingly limited, as the various alterations in the sizes of the standard nozzle with and without a bridge and variations in stack dimensions did not suggest the possibility of any marked improvement over the original arrangement.

(4)—The best results were obtained with annular-shaped nozzles constructed on a 14-in. diameter circle, used with a 24-in. diameter stack and a 26½-in. inside extension. The draft required to guarantee a free steaming locomotive under normal conditions will govern the size of the nozzle ports.

Recognition should be given especially to the fact that

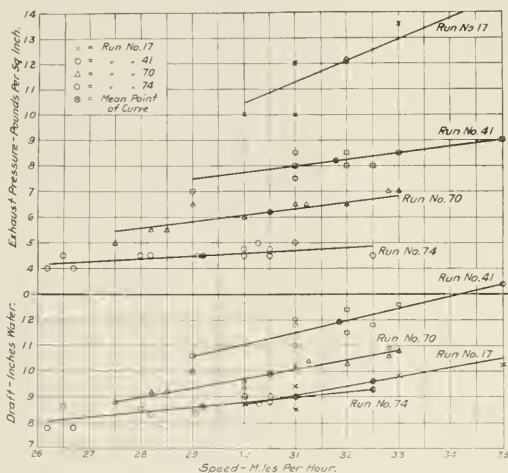

Fig. 24—Exhaust Pressure and Draft Diagrams for Runs 17, 41, 70 and 74, Showing Graphically the Improvement Effected in Draft Efficiency.

the data secured and the results obtained were made possible by the opportunity presented for the operation of the locomotive in special service, where all of the operating conditions were under the control of those in charge of the test. To this opportunity is due the ability to observe the effect of slight changes in the front end arrangement which could not have been detected under less favorable conditions.

The results that have been obtained by changing the front end arrangement of this class of mountain-type locomotives suggest that there is a wide field for improvement in draft conditions on other modern types of locomotives, and it is not at all improbable that the same principles might be applied to smaller locomotives with equally good results. As has already been stated the same principles are now being applied to a Norfolk & Western class M-2 Consolidation type freight locomotive. Encouraging results have already been realized in an increase of 39 per cent in draft, a decrease of 22 per cent in exhaust pressure, and an

increase in draft efficiency of 76 per cent. Efforts are being continued with the expectation of augmenting this favorable showing.

RULES FOR DELIVERY AND TRANSFER OF LOCOMOTIVES

The following rules for the purpose of expediting the delivery of new locomotives from the builders and also of facilitating the movement of locomotives to and from foreign line shops for repairs will be issued at the instance of Frank McManamy, mechanical assistant to the director of the division of operation:

Builders will be required to put the locomotive in condition for service before leaving the plant, and new road locomotives, except oil burners moving over lines which are not equipped to provide fuel, will be delivered under steam and be used in hauling a train when practicable. They will be accompanied by a messenger furnished by the builders, whose duties will be to see that bearings run cool and that the machinery is properly cared for until the locomotive is delivered.

Road locomotives repaired at foreign line shops will be returned to the home line under steam, hauling a train when practicable.

Road locomotives sent to foreign line shops for repairs will be sent under steam when their condition will permit, hauling a train when practicable.

Each road will give to such locomotives the same care and attention they give their own power and will be held responsible for their condition whether delivered to connections or home line.

The use of such locomotives when moving under steam will be accepted as full payment for transportation charges.

Such locomotives will be given preferred movement and will not be held at terminals except for rest for crews, and necessary repairs. Switching locomotives and other light locomotives not suitable for service on delivering line, and oil burners passing over lines which are not equipped to provide fuel, may be handled dead in train in the usual way.

To avoid disputes as to payment of rental for United States locomotives when transferred from one railroad to another, the following rule will govern: "All mechanical delay at the point of delivery, i. e., the necessary delay in making the locomotive ready for service, will be charged to the delivering road. All delay at such points after the locomotive is made ready for service will be charged to the receiving road."

SCHEDULE FOR THE APPLICATION OF SUPERHEATERS

Circular letters have been sent out by the regional directors, stating that for the purpose of helping to conserve fuel and increase the efficiency of locomotive operation, it has been decided to put into effect a locomotive superheater schedule as follows:

1. Locomotives in shop receiving Class 1, 2 or 3 repairs will be superheated as material is available and labor conditions will permit.

2. Locomotives in freight or transfer service, having 30,000 lb. or more tractive power, and in passenger service having 25,000 lb. or more tractive power, will have preference, and locomotives with the longest prospective life will be first equipped.

3. If superheater material is on hand for locomotives not covered by the above ruling it should be used on smaller engines if not interchangeable with larger ones; the idea being to obtain the benefit of its use rather than to have it remain in stock because of not conforming to the above requirements.

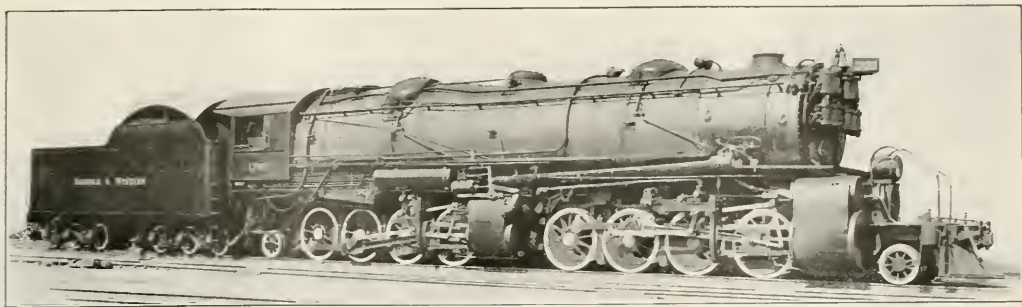

N. & W. 267-TON MALLET LOCOMOTIVE

Tractive Effort 104,300 Lb. Compound, 135,600 Lb.
Simple; The Tender and Its Trucks of Unusual Design

BY H. W. REYNOLDS

THE Norfolk & Western has used Mallet locomotives in general road service for the past five years. Realizing the need of a more powerful locomotive of this type, it has built and now has in use a large 2-8-8-2 Mallet. This locomotive, known as Class Y2, was built in the company's shops at Roanoke, Va.

On account of the limited clearances, compactness in design was necessary in order to obtain proper proportions. It was found that low pressure cylinders 39 in. by 32 in. were as large as could be used, and in order to secure a cylinder ratio of 2½ to 1 it was necessary to use high pressure

the flexible connections in the oil pipes to the low pressure cylinders, which have been a source of trouble. All other cylinder lubrication is furnished by sight feed lubricators.

The pistons are built up of cast steel centers with cast iron wearing rings. While this design is not as light as the rolled steel piston, it is desirable because of the ease with which a new wearing ring may be applied, without necessitating the piston being again fitted to the rod.

Steam distribution is controlled by the Baker valve gear and the Norfolk & Western Class K1 standard power reverse gear. Hancock pneumatic cylinder cock operating cylinders

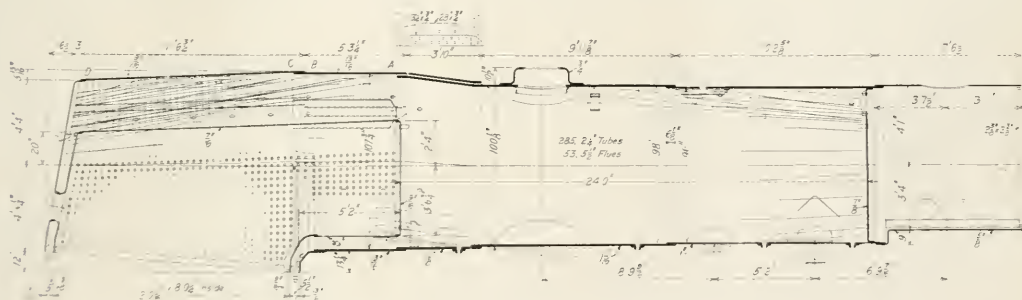

Boiler of the Norfolk & Western Mallet

cylinders 24½ inch by 32 inch, and a boiler pressure of 230 lb. per sq. in. Another evidence of close clearances will be seen in the arrangement of the pop valves, which are laid flat on the boiler, with a shield between them to deflect the steam upward. It will also be noticed that the air pumps and bell are located on the boiler front, the bell being operated by means of a Gollmar bell ringer.

Both high and low pressure cylinders are equipped with piston valves. The valves in the low pressure cylinder are 17 in. in diameter, while those of the high pressure cylinders are 14 in. in diameter. In order to obtain steam and exhaust passages of ample area, free from abrupt bends, it was found desirable to make the low pressure valves outside admission. The McCord force feed lubricator is used for lubricating the low pressure cylinders. This lubricator is used to eliminate

actuate the cylinder cocks, and the grates are operated by means of the Franklin steam grate shakers.

The driving wheels are equipped with flanged tires throughout and the locomotive is designed to take 18-deg. curves. The frames, driving boxes, driving wheel centers and all frame braces are of cast steel. The cylinders are of gun iron. Care was exercised in the design of all castings and cast steel was used liberally in order to reduce the weight and secure a boiler of ample proportions.

The boiler is of the extended wagon top type, with a central dome and is equipped with a 53-unit Type A superheater. The firebox with its liberal grate surface of 96 sq. ft. is equipped with the Security arch supported on five water tubes 3 in. in diameter. There are 53 flues 5½ in. in diameter, and 285 tubes 2¼ in. in diameter, 24 ft. long over

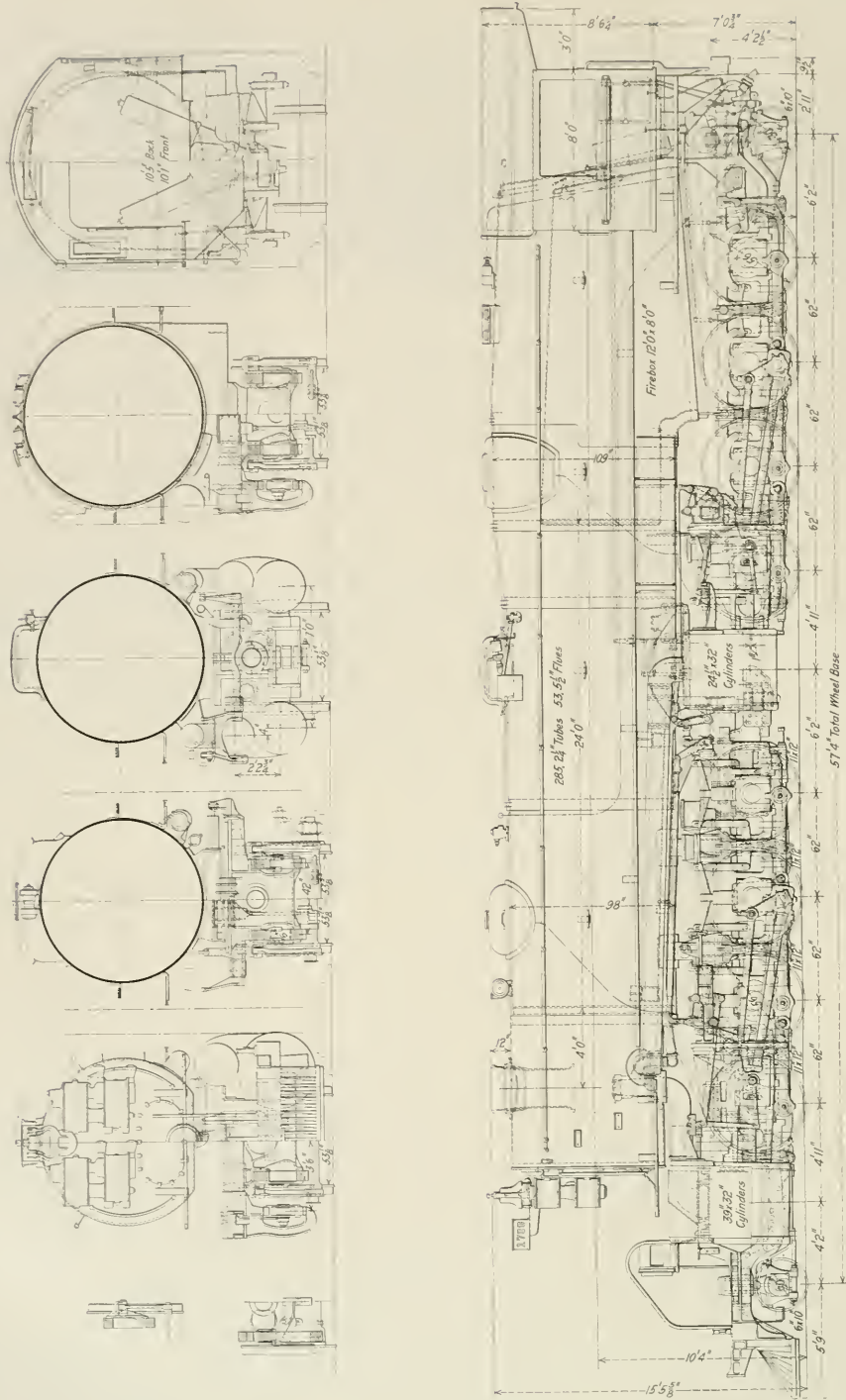

Elevation and Sections of the Norfolk & Western Mallet Locomotive

tube sheets, and a combustion chamber 5 ft. 2 in. in length.

The front end is arranged for the use of an annular ported exhaust tip. The ports are laid out in a 12-in. circle and are proportioned to provide an area equivalent to that of an 8-in. circular nozzle. The emergency exhaust from the high pressure cylinders is led through an elbow, cast integral with the exhaust stand, to an outside annular chamber. This

a thin plate 13/16 in. thick in this location, over 3,000 lb. of boiler plate steel was saved and the required strength of the boiler maintained. The dome is located on the second course of the boiler just in front of the gusset sheet, in order to obtain sufficient height for the Chambers' throttle valve. The

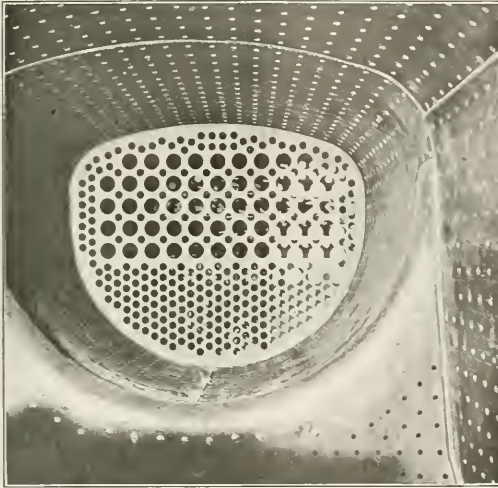

Electrically Welded Firebox Seams

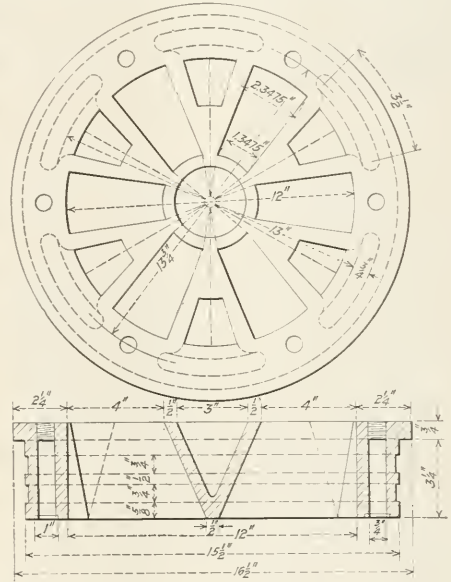

The Annular Ported Exhaust Tip

discharges through an opening in the exhaust tip placed between the low pressure exhaust ports. The exhaust pipe discharges into an inside extension stack 22 in. in diameter, the bottom of which is located about 22 in. above the tip.

An unusual feature of boiler construction will be noticed in the fourth ring over the combustion chamber. By using

firebox and combustion chamber of the boiler are electrically welded throughout, thus eliminating flanging and the possibility of cracks after two or three years of service. The tubes are located well up in the back tube sheet to prevent clogging.

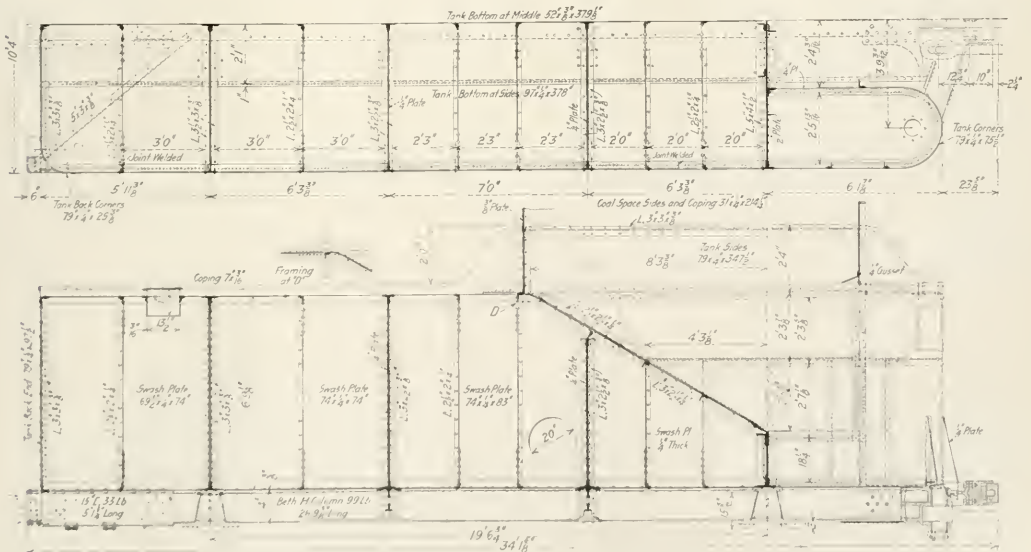

Elevation and Half Plan of the Tank

It has been found that a number of the lower tubes located close to the bottom of the sheet are practically of no value, as they require constant attention to keep them open.

The boiler is fitted with the Sentinel low water alarm. The value of this device lies not only in the elimination of burnt or damaged crown sheets, but the water in the boiler may be worked at a lower level, resulting in increased superheat temperatures. The efficiency of the superheater on large locomotives, particularly on those with long boilers, is frequently

time remains after the alarm has sounded to fill the boiler to the proper level without danger of damage.

Two Sellers non-lift injectors, each having a capacity of 7,500 gal. of water per hour, are located one on each side of the engine under the cab with the steam control valves

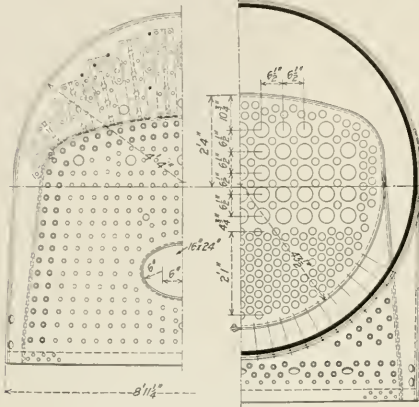

The Back Head and Tube Sheet Layout

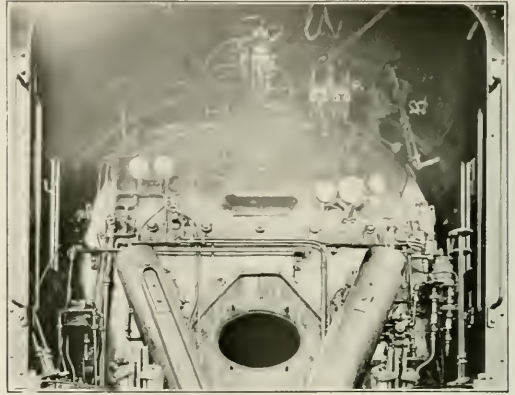

Interior View of the Cab

perceptibly lowered, due to the tendency of some engineers to carry the water at too high a level. Perfect confidence may be had when carrying the water at a low level on a locomotive equipped with this alarm, for the reason that sufficient

located outside and in front of the cab. Coal is fired by means of the Duplex stoker, and from road tests the boiler has been found to steam freely.

The smokebox front is of steel plate in order to provide support for the air pumps.

Among the special features of the equipment of the locomotive are Radial buffers, Graham-White Perfect sanders, and Pyle type K headlight equipment.

The construction of the tender differs materially from usual

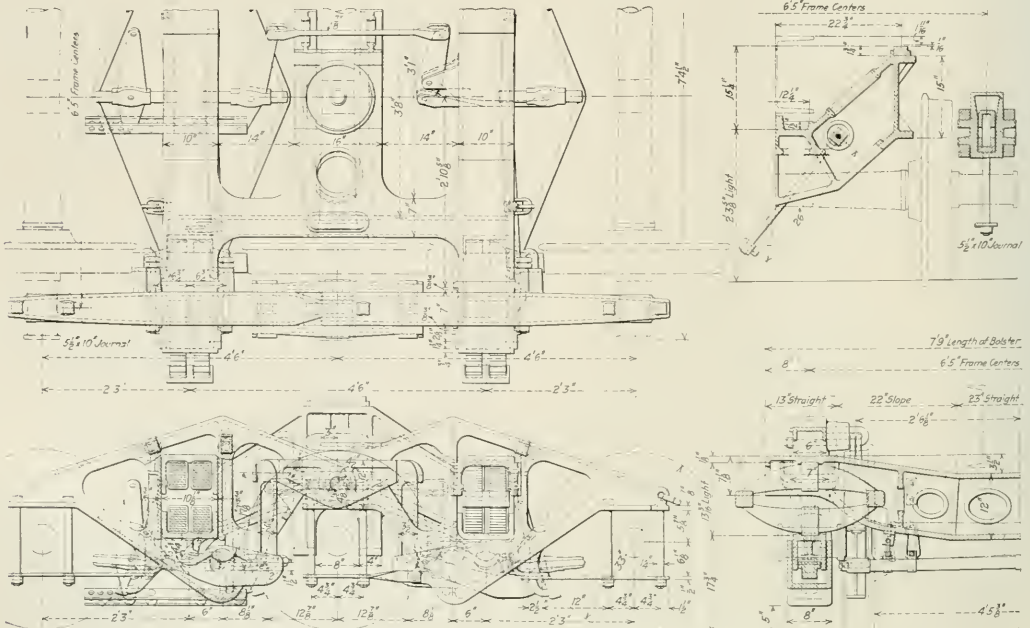

Plan and Elevation of the Norfolk & Western Class T-27 Tender Truck

practice. The tank is made of structural shapes and the frame is built into it, resulting in increased strength and decreased weight. The body bolsters are located in the tank over the truck centers and two intermediate diaphragms are located between the body bolsters. Between the diaphragms, between diaphragms and bolsters, and between the rear bolster and the end of the tank, lateral bracing is placed to furnish the necessary strength against bulging. The center sill, riveted underneath the tank, is a Bethlehem H-section, which extends from a point just in front of the front truck center to a point back of the rear truck center. Carefully fitted and riveted to the front end of the center sill is a steel casting arranged to support the front water legs. This casting also contains pockets to receive the drawbar and safety bars. A

gal of water and 20 tons of coal. The design has been found to be very successful.

The tender is carried on two 75-ton six-wheel non-pedestal trucks, the design of which is a departure from the Lewis six-wheel freight car truck in use on the Norfolk & Western. Helical springs are used in the Lewis truck and the openings in the side frames for receiving the springs and bolster arms are so located as to throw two-thirds of the load coming on each side frame on the journal boxes of the outside pairs of wheels. By this method proper weight distribution is obtained, but it is necessary in order to keep the wheel base within reasonable limits to have the nest of springs in each side frame close to the outside pairs of wheels and arrange the neck of the body bolster to clear the wheels with springs solid.

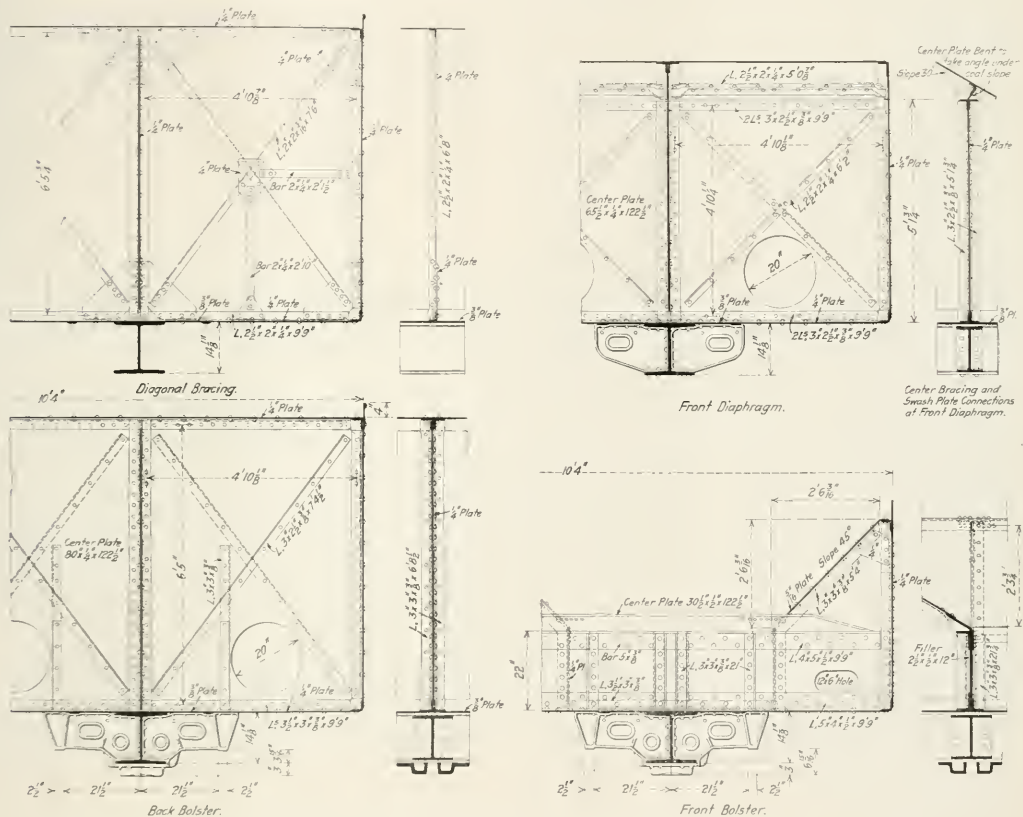

Sections Showing the Tender Bolster and Diaphragm Construction

steel casting is riveted to the back end of the center sill, to either side of which draft arms are riveted. These draft arms extend to the rear of the tank, where they are held in position by knee braces built up of plates and angles. Sessions draft gear is used in connection with the Farlow one-key attachment.

Short steel castings arranged with side bearings are fitted each side of the center sill over the truck centers and are securely riveted to the center sills and tank floor. These castings serve to transfer the load from the body bolsters to the truck centers. Cast steel knees are riveted to the center sill and tank floor at each diaphragm to provide the center sill with lateral stiffness. The tender has a capacity of 12,000

When the attempt was made to use elliptic springs on the Lewis truck it was found difficult to get them in and clear the wheels, so the 75-ton elliptic spring tender truck, known as Class T-27, was developed. On this truck the openings in the side frames are located midway between each two pairs of wheels. This location causes the middle pair of wheels to be loaded in a larger proportion than the outside pairs. In order to remove the excess load from the middle wheels, the elliptic springs are placed on seats, each of which rests on one end of a lever pivoted in the side frame between the opening and the middle wheels. The other end of each lever rests against the bottom end of a strut, the top ends of which rest against the end of a lever pivoted to the side frames

over the middle journal boxes. It will be seen that with the levers properly proportioned, the weight on the springs will cause an upward thrust to be exerted on the levers pivoted to the side frames over the middle journal boxes equal to the amount of the excess weight on the middle pair of wheels. This relieves the middle wheels of the excess loading and gives the same weight on the rail for all three pairs of wheels.

To one side frame on each side of the truck is bolted rigidly the journal boxes of the outer and middle pairs of wheels, while to the other frame is bolted the journal box of the outer pair of wheels, and the end of the frame is passed into and rests on the rigid side frame over the middle journal box to form a flexible connection.

The usual practice of making the members at the top and bottom of the side frame openings parallel is not followed for the reason that the load is applied to the side frames at a single point under the center of the columns next to the middle wheel, the columns and wearing surfaces toward the outer wheels acting only as guides for the bolster arms. This permits the side frames being designed in perfect truss form.

Axles with standard M.C.B. 5½ in. by 10 in. journal boxes are used. The brake beams are hung from the side frame and the design of brake rigging is the same as that in use on the Lewis truck. The truck bolster is of cast steel in one piece, with the ends of the arms arranged to fit over and rest on the elliptic springs. On account of ample space being provided by the design of the tank, the side members of the body bolster are made deep where they pass over the middle axle. Ample wearing surfaces are provided, and the absence of all bolts and pin connections will be noted.

The principal data and dimensions of this locomotive are:

GENERAL DATA	
Gage	4 ft. 8½ in.
Service	Freight
Fuel	Bit. coal
Tractive effort, compound	104,300 lb.
Tractive effort, simple	135,600 lb.
Weight in working order	535,000 lb.
Weight on drivers	472,000 lb.
Weight on leading truck	28,000 lb.
Weight on trailing truck	35,000 lb.
Weight of engine and tender in working order	747,000 lb.
Wheel base, driving, both units	15 ft. 6 in.
Wheel base, total	57 ft. 4 in.
Wheel base, engine and tender	92 ft. 11¼ in.
RATIOS	
Weight on drivers ÷ tractive effort	4.52
Total weight ÷ tractive effort	5.53
Tractive effort X diam. drivers ÷ equivalent heating surface	680.6
Equivalent heating surface* ÷ grate area	89.4
Firebox heating surface ÷ equivalent heating surface, per cent.	5.6
Engine truck wheels ÷ equivalent heating surface*	55.0
Total weight ÷ equivalent heating surface*	62.3
CYLINDERS	
Kind	Compound
Diameter and stroke	24½ in. and 39 in. by 32 in.
VALVES	
Kind	Piston
Diameter	H. P., 14 in., L. P., 17 in.
WHEELS	
Driving, diameter over tires	56 in.
Driving, thickness of tires	3 in.
Driving journals, main, diameter and length	11 in. by 12 in.
Driving journals, others, diameter and length	11 in. by 12 in.
Engine truck wheels, diameter	30 in.
Engine truck journals, diameter	6 in. by 10 in.
Trailing truck wheels, diameter	30 in.
Trailing truck, journals	6 in. by 10 in.
BOILER	
Style	Wagon top
Working pressure of tires	230 lb. per sq. in.
Outside diameter of first ring	.98 in.
Firebox, length and width	12 ft. by 8 ft.
Firebox plates, thickness	16 in.
Firebox, water space	17 in.
Firebox, front 3¼ in. back 5 in., sides 4½ in.	
Tubes, number and outside diameter	285—2¼ in.
Flues, number and outside diameter	53—5½ in.
Tubes and flues, length	24 ft.
Heating surface, tubes and flues	5,834 sq. ft.
Heating surface, firebox including arch tubes	482 sq. ft.
Heating surface, total	6,316 sq. ft.
Superheater heating surface	1,510 sq. ft.
Equivalent heating surface*	5,581 sq. ft.
Grate area	.96 sq. ft.
TENDER	
Tank	Water bottom
Weight	212,000 lb.
Wheels, diameter	33 in.
Journals, diameter and length	5½ in. by 10 in.
Water capacity	12,000 gal.
Coal capacity	20 tons

*Equivalent heating surface = total evaporative heating surface + 1.5 times the superheating surface.

COAL GATE HOLDERS

BY JOHN H. NAGLE
Chief Draftsman, Buffalo, Rochester & Pittsburgh

Many forms of coal gate holders on locomotive tenders are in use and it is often difficult to keep them in good condition because they are subject to hard service, especially when loading the tanks at terminals.

To overcome this difficulty, the B. R. & P. has designed a simple arrangement composed of a chain and keeper. Referring to the illustration, *A* is an elevation and *B* a plan view of the tank showing the detail arrangement of coal gate, chain and keeper. The chain is a ¼-in. straight link standard chain, which is firmly riveted to the inside of the gate as indicated at point *C*. The keeper is also firmly

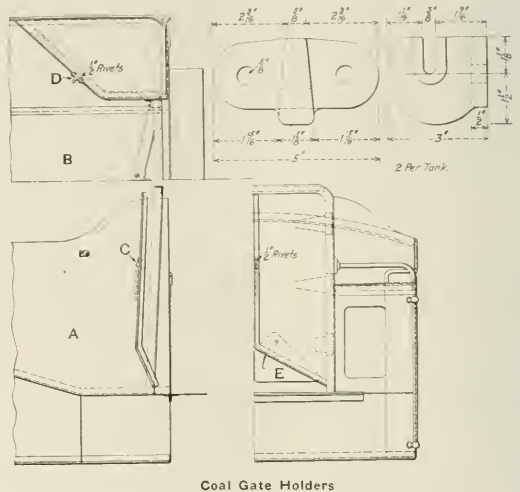

Coal Gate Holders

attached to the tank by ½-in. rivets as indicated at point *D*.

With this device the gate may be held in any position desired by simply hooking the proper link of the chain into the keeper. When the coal gates are closed the chains hang free, there being, of course, a chain and keeper for each door.

The small lifting gate marked *E* has been found useful in preventing the loss of coal, as for example, when moving a dead engine with a loaded tank. The entire arrangement has been satisfactory, meeting all the requirements of the enginemen and has, therefore, been adopted as standard.

TRAINS BY WATER-POWER.—The special correspondent of the Daily Mail, London, reports that in a debate on railways in the Spanish Senate, Senor Cambo said the government was occupied with a large scheme for the development of hydro-electrical energy, and more than hinted at the existence of a plan for working thus the main railways of the country. As the industrial development of Spain is held up for lack of communications and transport, and as transport at present depends on coal, the importance of this project can hardly be exaggerated. It is interesting to note also that practically all hydro-electrical plants in the country are run with German machinery, and that their usual commercial forethought has been displayed in a systematic cultivation of the subject as well as in a good deal of surveying and buying of properties where this power could be developed on a large scale. There is enough water-power in Spain to do the whole work of the country.

GAR DEPARTMENT



RECLAIMING CAR AXLES

The enormous increases in the prices of iron and steel products since the outbreak of the war have created a greater incentive for reclaiming materials. Heavy parts which are used in large numbers furnish especially attractive fields for effecting savings. Until quite recently the reclaiming of car axles has been practiced by very few roads, but at the present time it is being done at a number of shops and by a variety of methods.

There is no single process which is best under all conditions. There are four common defects for which axles, otherwise in good condition, may be removed from service. The collar may be too thin or the journal may be too long or the

it down under a steam hammer from the center to the collar on the wheel seat to increase the distance between the inside fillets on the journals. The collar on the journal is also broken down with swedges in this operation. Each end of the axle is lengthened about one-fourth to one-half inch in this way. After this a short heat is taken on each end of the axle and it is upset in a 6-in. Ajax forging machine. The machine in which this work is done has a special backstop which insures the axles being made to the proper length. About $\frac{1}{8}$ -in. is left at each end to be turned off in the lathe and the collar is made about $\frac{3}{8}$ -in. over size. To take care of any surplus stock on the axle, a groove is provided in the die at the end of the collar into which the extra metal is forced when the axle is upset. After the forging work is fin-

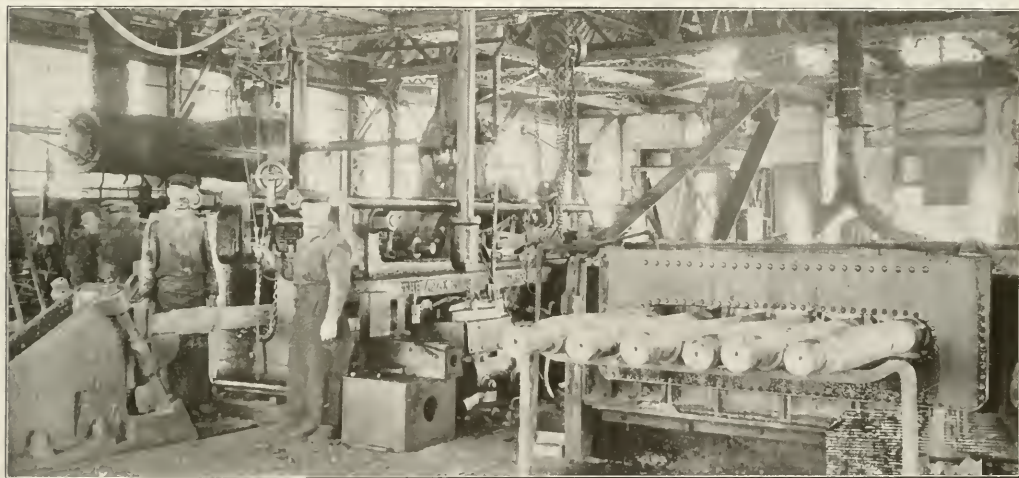

Forging Machine with Special Backstop for Reclaiming Axles.

diameter of the wheel seat or journal may be under the limiting dimensions. In the first two cases the axle can be built up at the point where the greatest wear has occurred by welding. The chief advantage of this method is that the axle after reclaiming is of the same nominal capacity as before. In case the diameter of the wheel seat or the journal is below the limit, it is the usual practice to convert the axle to the next smaller size.

The reforming of the axles is a job requiring special equipment. Where a forging machine of sufficient capacity is available the work can be done quickly and cheaply. About two years ago the Atchison, Topeka & Santa Fe fitted up a forging machine at its Topeka shop for doing this work and has reclaimed several thousand axles. The first operation in reclaiming the axle is to heat one end in a furnace and draw

ished the axles are placed in a furnace and thoroughly annealed to restore the proper structure in the metal. This is an essential part of the work, as it has been found that axles taken from service, though apparently in good condition, often will not pass the M. C. B. drop test due to fatigue and crystallization. Axles which have been reformed by the process described above and properly annealed are superior to new axles as the increased diameter at the center gives them additional strength.

The work of reclaiming axles cannot be handled satisfactorily on a forging machine of less than 6-in. capacity. There are few railroad shops that have such large machines available, but the savings effected are so great that roads having a considerable number of cars would find it economical to install machines for this work alone. At the present time

the cost of a new 5-in. by 9-in. axle is about \$35.60. The scrap value of a 5½-in. by 10-in. axle is \$17.30 and the cost of reclaiming it in the forging machine is \$1. Thus, for each 5½-in. by 10-in. axle made into a 5-in. by 9-in. axle there is a saving of \$17.30. The savings effected by reclaiming 5-in. by 9-in. and 4¾-in. by 8-in. axles are \$12.80 and \$8.55, respectively. During the first eleven months in which the forging machine at Topeka was in use there were reclaimed 1,120 5½-in. by 10-in., 1,427 5-in. by 9-in., and

little sledging is usually necessary, especially on the center sills, and if the device shown between the sills is set properly the operator simply sledges the bent sill until it is in place. This operation is now done 35 to 40 per cent cheaper than

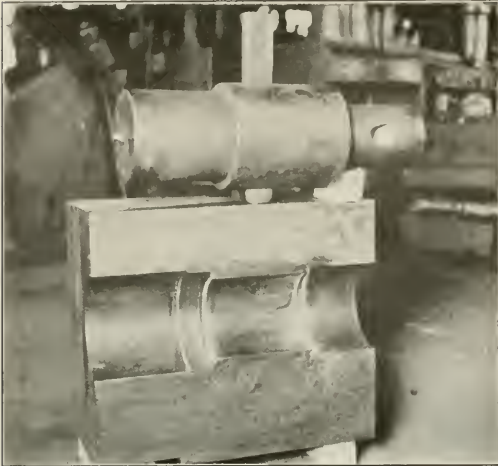

Dies Used for Forming the Ends of the Axles

1,589 4¾-in. by 8-in. axles. The savings effected amount to more than \$40,000, although the machine was in use only a part of the time on this work.

STEEL CAR SILL STRAIGHTENER

BY E. A. M.

The ordinary method of straightening center sills, end sills, bolsters and the diagonal braces of steel gondola freight cars consists in taking the sills apart, straightening them separately and reassembling. This process is expensive and requires considerable time. In many cases the following method may be used to good advantage. Referring to the illustration, the dotted lines indicate in a general way the position and shape of sills after they become bent, due to excessive buffing shocks or other mistreatment. The center sills, running lengthwise of the car, usually buckle as shown, and the end sill is bent back at the center. If the bent sills can be heated and a strain brought on the drawbar all the sills may be straightened at once with the aid of a little sledging.

The device shown between the center sills consists of two inverted L-shaped castings. They are 10 in. in width between the vertical sides when closed and can be spread to 15 in., or whatever the distance is between center sills by means of the turnbuckle indicated. The flange on top holds the device in position in addition to providing a means of lifting it in and out of place.

The damaged car is coupled to another car by means of the link and two 50-ton hydraulic jacks are placed between the cars. All bent parts are heated simultaneously by two or three men using oil burners, and when not enough, a man operates each jack, thus tending to increase the distance between the cars and thereby pull the bent parts straight. A

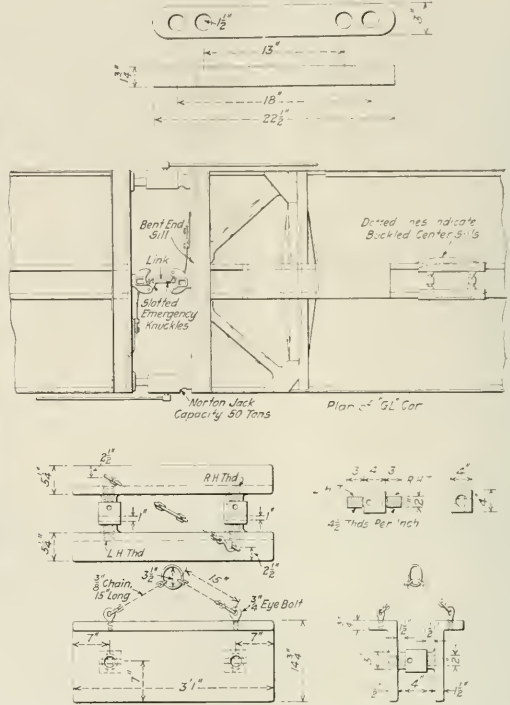

Method of Straightening Steel Car Sills Without Removal from the Car

by the older method of taking everything apart, straightening the parts separately and reassembling. In addition to the saving in cost there is a material saving in time and the car is returned to service quicker.

In case the center sill shows evidence of weakness or a crack starts in straightening, it may be reinforced locally.

HYDROGEN AS A SUBSTITUTE FOR PETROL.—To replace the shortage of petrol in Switzerland, pure hydrogen has been experimented with for some time, says the Commercial Motor. Hydrogen, as is well known, is the richest combustible gas and contains practically double the calorific values of petrol. The main drawback of hydrogen is its weak density, which necessitates a considerably higher compression as compared with coal gas in containers.

THE FRENCH EQUIPMENT PROBLEM.—Of the 376,000 cars available on the French railways in August, 1914, 55,000 were lost to the railways, presumably as the result of enemy occupation of territory, says an article in a recent issue of the *Industrial et Commercial Français*. Even with the addition of the vehicles provided by the British authorities, an assistance which is described as invaluable, the total rolling stock available has been inadequate to meet all demands, and with the utmost relief which can be obtained by the utilization of highways and inland navigations, it is held that the traffic needs the construction of more than the 33,000 cars.

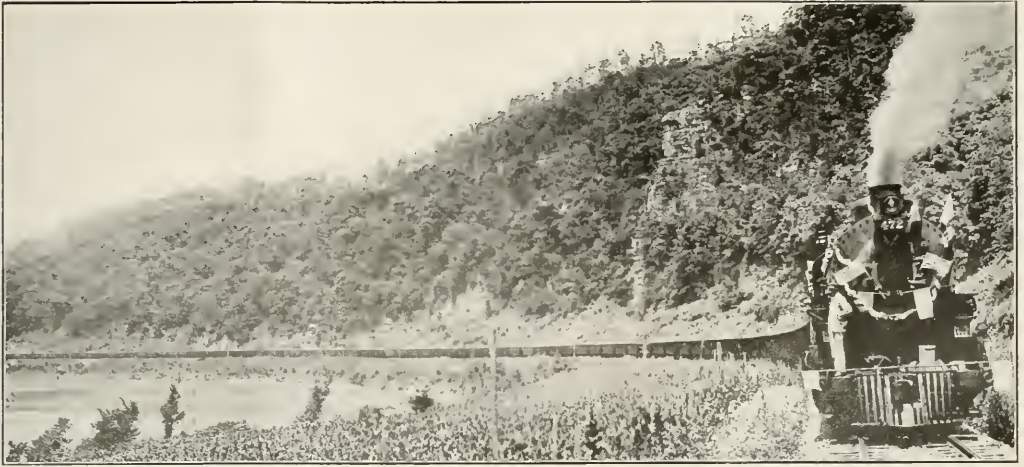

Automatic Straight Air Brake Test Train of 100 Cars on the Virginian Railway

ROAD TESTS OF THE A. S. A. BRAKE

100 Car Train Run on Virginian with A. S. A. and Combinations of A. S. A. and Westinghouse Brakes

ON July 4, 1918, a train of 100 loaded coal cars having a gross weight, exclusive of the locomotive and caboose, of about 7,600 tons, equipped throughout with Automatic Straight Air brakes, was run over the Virginian Railway from Princeton, W. Va., to Roanoke, Va. This train was run as the last of a long series of tests, including both rack and road tests, which have been conducted by the Bureau of Safety of the Interstate Commerce Commission to determine the practicability of the Automatic Straight Air brake system, controlled by the Automatic Straight Air Brake Company, New York. Following the 97-mile run from Princeton to Roanoke, the Automatic Straight Air brake equipment on fifty cars was replaced with the Westinghouse equipment generally in use on the class of cars of which the train was made up. The train, thus equipped, was run from Roanoke to Victoria, Va., a distance of 123 miles, with the A. S. A. equipment at the head of the train and the Westinghouse at the rear, and from Victoria to Sewalls Point (Norfolk), Va., 120 miles, with the Westinghouse equipped cars at the head of the train and the A. S. A. cars at the rear.

The test train was made up of 100 52½-ton hopper coal cars averaging about 41,600 lb. light weight, a Mikado type locomotive and a caboose chronograph car. Helper service was available throughout the trips over the Third and Second divisions, but the helper locomotive had no part in the brake operations. The cars are regularly fitted with Westinghouse 10-in. freight brake equipment, including K-2 triple valves.

FUNCTIONS OF THE A. S. A. BRAKE

The Automatic Straight Air Brake car equipment of the type with which the train was fitted, consists of a triple valve with separate service and emergency sections, and a change-over valve.* In addition to the usual type of brake cylinder and auxiliary reservoir, the equipment includes a

service reservoir which during service operations is in effect a part of the train pipe, providing the necessary train line volume from which to furnish air for service applications. The engine equipment consists of a high volume feed valve and a compensating valve. The former performs the same functions as and replaces the slide valve feed valve, while the latter replaces the equalizing discharge valve of the engineer's brake valve, and in addition to performing the functions of that valve, automatically maintains train pipe pressure while the brake valve is in lap position, at whatever point was established by the preceding position of the valve.

Essentially the functions of the Automatic Straight Air brake equipment are as follow:

- (1) Rapid serial action in service applications and in quick release.
- (2) The maintenance of uniform and constant brake cylinder pressure, irrespective of piston travel or cylinder leakage. The cylinder is fed from the brake pipe, the pressure in which in turn is maintained by the compensating valve while the brake valve is in lap position.
- (3) Graduated release, permitting a variation of brake cylinder pressure at the will of the engineman.
- (4) Quick release when desired.
- (5) Emergency applications of the brake available at any time during or after any service application, and an automatic emergency application on full depletion of train pipe pressure.

PURPOSE OF THE TESTS

The purpose of the three 100-car test runs, the first of which was made on July 4, was, first, to demonstrate the ability of the A. S. A. equipment to handle the longest trains ordinarily operated under any conditions, down long heavy grades, and, second, to determine the ability of the A. S. A. equipment to operate successfully when combined in trains, including brakes of existing types. The train was equipped for the collection of complete data as to the performance of the brakes on practically every car, each car, with one ex-

*For a complete description of the three unit type A. S. A. car equipment (the type with which the test train was equipped), see the *Railway Mechanical Engineer* for November, 1917, page 633.

ception, being fitted with a trainagraph, recording brake pipe, auxiliary reservoir and brake cylinder pressure. A chronograph in the caboose provided a continuous chart on which was recorded the time of each brake valve movement, the time of application and release of the brakes on the first, fiftieth and one-hundredth cars, and the usual data as to speed, mileposts, etc. In addition to the trainagraph record of brake valve movements, constant telephone communication was maintained between the locomotive and the caboose. The locomotive and chronograph car each was equipped with a speed recorder. In addition to the equipment for the observation of brake conditions, pyrometer connections were made through slip rings on the axle to the rim, plate and hub of one of the rear wheels on the one-hundredth car, as well as to the brake shoe, from which temperature observations were taken during periods of heavy braking.

To demonstrate the characteristics of the Automatic Straight Air Brake for heavy grade work, the First Division of the Virginian Railway from Princeton, W. Va., to Roanoke, Va., was chosen. Beginning at a point about two miles east of Princeton is a 1.5 per cent compensated grade, nearly 11 miles long, ending at Kellysville, which, from the standpoint of braking conditions, is the greatest obstacle imposed in the way of loaded train movement. The length of trains operated down this grade is limited to a maximum of

practiced with existing types of equipment, brake cylinder pressure once established, need never be fully released as long as a retarding force is required. On the basis of a braking power of 60 per cent of the light weight of the cars at 50 lb. brake cylinder pressure, an average co-efficient of brake shoe friction of 20 per cent and a train resistance of about 3.5 lb. per ton, a rough calculation indicates that a uniform speed of 15 miles an hour should be maintained down a 1.5 per cent grade with a constant cylinder pressure of 20 lb. The schedule of the test run down Kellysville hill, therefore, called for the maintenance of approximately 20 lb. cylinder pressure, that is, a 10-lb. brake pipe reduction, to be slightly raised or lowered by the manipulation of the brake valve between lap and running positions, and lap and application positions, as the speed of the train seemed to require.

EVENTFUL RUN DOWN KELLYVILLE HILL

Three incidents interfered with the strict following out of this plan during the first three and one-half miles down the hill. At the first application of the brakes an unnecessarily large brake pipe reduction was made and held too long, with the result that the train was stopped after having proceeded about one and one-half miles from the top of the grade. During this stop a maximum cylinder pressure of 32 lb. was

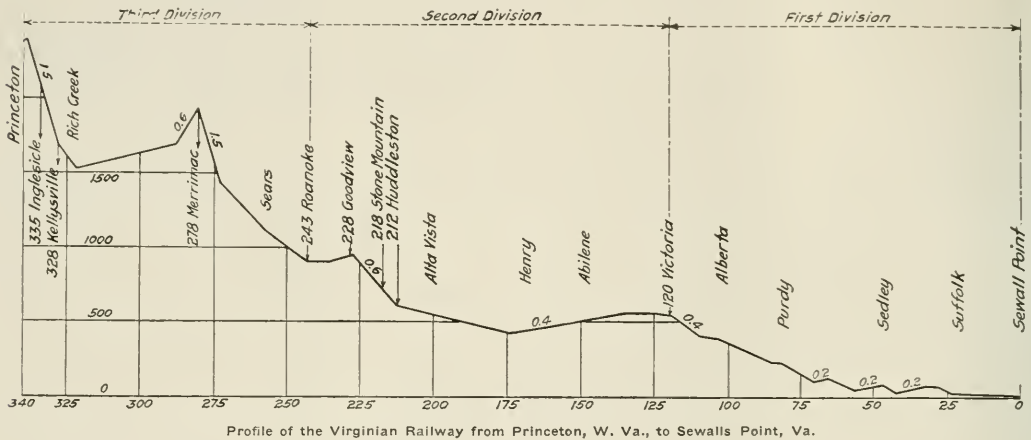

85 loaded cars. The uncertainty of the control of the brakes throughout the train has made impracticable the successful operation of longer trains.

From Kellysville east for about two miles the grade is slightly ascending, followed by about four miles of .8 per cent descending grade. From Rich Creek this grade is followed by about 4½ miles of light ascending grade, most of which does not exceed .2 per cent. Succeeding this is another 1.5 per cent descending grade. This one, however, does not exceed seven miles in length and offers less difficulty in train control than Kellysville hill. The remainder of the First division is made up of a broken light, eastbound descending grade and offers little of interest from the standpoint of brake operation.

From Princeton to Kellysville the cars were all operated in graduated release, and 90-lb. train line and 110-lb. main reservoir pressure were maintained, in accordance with the practice of the road. When operating in quick release position the Automatic Straight Air brake equipment provides the engineman with direct control of the brake cylinder pressure throughout the train. With the train so equipped, instead of resorting to the cycling method of brake operation

recorded on the last car. The brakes were released and the train started in about eight minutes after the stop and about one minute later, when the speed had attained 11 miles per hour, an emergency application was effected by the blowing off of a hose on the rear end of the ninety-fourth car. This occurred just after a 10-lb. brake pipe reduction had been made on the engine; nevertheless, the emergency action was effective throughout the length of the train, which came to a stop without noticeable shock at either end. Following this incident, five minutes after the train had again been started, the train parted between the eighty-fourth and eighty-fifth cars, due to the slipping by vertically of the coupler knuckles. This occurred about four minutes after a brake pipe reduction of approximately 10 lb. had been made, and again the emergency application of the brakes brought both ends of the train to a smooth stop about 125 ft. apart.

The remaining eight miles of the grade, from Ingleside to Kellysville, were traversed in 30 minutes, without incident. From the time the brakes were applied after the train was started until the final stop in Kellysville yards, the brakes were never fully released. The brake cylinder pressure on the hundredth car varied up and down between 10 and 30 lb.

and with a few exceptions which were of only short duration the speed variations were between 14 and 21 miles an hour.

During the run ending with the stop at Kellysville, pyrometer readings of wheel temperatures on the one-hundredth car showed a maximum temperature of 280 deg. F. in the rim, 190 deg. in the plate and no rise in temperature in the hub of the wheel; the maximum temperature of the brake shoe was 670 deg. F. These maximums were reached as the train stopped at Kellysville. Examination of the wheels on the rear half of the train indicated a high degree of uniformity in temperature. That the same condition applied generally throughout the train is well indicated by the aver-

The Second division is characterized by a gradually descending profile for the first half of the distance, the maximum grade being .0 per cent descending eastbound. The longest descent of this gradient begins about two miles east of Goodview and with the exception of the fourth mile, in which the grade is reduced to .1 per cent, this descent is continuous for 13 miles, ending about one mile west of Huddleston. The remainder of the grades are light and short and require very little braking. The practice on this, as well as on the First division, is to maintain 70 lb. train line and 90 lb. main reservoir pressure, and this practice was followed in the test.

An average speed of 20 miles an hour was maintained down the long .0 per cent grade east of Goodview with very little variation. The maximum variation occurred when the speed reached 30 miles an hour, just preceding the stop at Stone Mountain, which is located eight miles east of the top of the grade. On the run from Stone Mountain to Huddleston an average speed of 20 miles an hour was maintained with a maximum variation of not more than two miles an hour. The train was handled on this grade by the one application method, the brake cylinder pressure on the first 49 A. S. A. cars being graduated up or down as

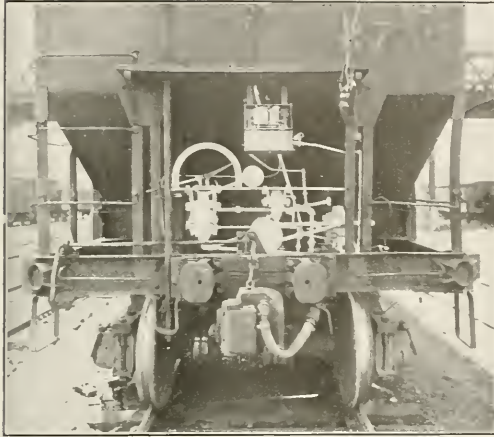

The Rear End of the One-Hundredth Car, Showing the A. S. A. Brake Equipment and the Trainagraph

age cylinder pressures maintained during the run from Ingleside to Kellysville. Following the test, the trainagraph records of cars 1, 25, 50, 75 and 100 were removed and the average cylinder pressures obtained by planimeter measurements. These averages were: Car 1, 24.88 lb.; car 25, 24.4 lb.; car 50, 21.36 lb.; car 75, 25.84 lb., and car 100, 16.56 lb., an average of 21.81 lb.

At Kellysville the brakes on the last 50 cars were changed from graduated release to quick release, under which conditions the train ran down the four-mile .8 per cent grade. Twice during this part of the run the train broke in two, in both cases immediately following the release of the brakes after service applications. In the first instance a knuckle pin was sheared and in the second a knuckle was broken. The broken section of the knuckle, while largely a new break, showed a flaw in the casting which may have contributed to its failure. It is worthy of note, however, that in neither case was the parting of the train preceded by a shock of any severity. In both cases the train was brought to a smooth stop.

PERFORMANCE OF MIXED EQUIPMENT

At Roanoke the A. S. A. brake equipments were replaced with the Westinghouse K-2 triple valves, on one-half of the cars in the train. Following the completion of this work, on July 8 a run was made over the Second division from Roanoke to Victoria, Va., with 49 A. S. A. cars at the head end of the train, followed by 50 Westinghouse cars and one A. S. A. car at the rear of the train. The entire 50 cars with the A. S. A. equipment were operated in graduated release.



Interior of the Chronograph Car

conditions required. During this period some of the Westinghouse brakes applied and leaked off, but at no time during this run was there an application of the brakes on the one-hundredth car until the heavy train pipe reduction made just preceding the stop at Huddleston.

The run over the last half of the Second division was made with the first 25 A. S. A. cars in graduated release and the remainder in quick release, the brakes being manipulated in the usual manner. Following this change in the operation of equipment, two water stops were made without shock at the rear end of the train.

At Victoria the 50 Westinghouse cars were placed at the head of the train with the 50 Automatic Straight Air brake cars at the rear, all being placed in quick release. On July 9

the train was run from Victoria to Sewalls Point, Va., over the First division, a distance of 120 miles.

This division is characterized by light rolling grades with an aggregate eastbound descent of about 500 ft. in the first 63 miles. Although the maximum grade is .6 per cent, considerable difficulty has been experienced in properly controlling the speed of long trains because of the broken nature of the grades. In the operation of 100-car loaded trains, which are regularly handled over this division, practically no braking is done to control the speed of the train. In order to insure the application and release of all brakes in the train, such a heavy brake pipe reduction is required that it is practically impossible to make an application without bringing the train to a full stop. It is the practice to let the trains run, which at many points results in the attainment of undesirably high speeds before the speed is checked by a change in the grade.

During the test run several brake applications were made to control the speed, the reductions ranging from 5 lb. to 14 lb. In every case the brakes applied on the one-hundredth car and the smoothness with which the train was handled indicated a uniformity of brake application throughout the train. In one case a break-in-two resulted from an attempt to release without sufficient time in full release position, the brake valve being returned to running position after a period of only nine seconds in release. Following the customary practice with the A. S. A. brake, however, in which the valve is maintained in full release position for not less than 25 seconds, no difficulty was experienced in releasing the brakes throughout the train. The release on the one-hundredth car was obtained in 35 seconds from the time the brake valve was placed in release position, following a 5-lb. train pipe reduction. In fact, there appeared to be no appreciable difference in the time required to effect the release of the brakes on the last car, irrespective of the extent of the train pipe reduction.

It seems evident that the Automatic Straight Air brake, even when operating with other equipment in the same train, offers the possibility of materially increasing the flexibility of train control.

ADVANTAGES DEMONSTRATED BY THE TESTS

Undoubtedly the most important consideration in estimating the value of any device having to do with train control is the degree of safety of train operation attending its use. A braking system to be highly successful must be capable of retaining the train constantly under a control which not only provides against the loss of life, but also protects the equipment and lading in the train from damage in the face of any situation which reasonably may be expected to arise. The value of the Automatic Straight Air brake in this respect was demonstrated several times during the 100-car tests. The attainment of emergency applications of the brakes and smooth stops of this long train when operating at slow speeds, ranging from 11 to 14 miles an hour, in one case immediately following a brake pipe reduction and in another immediately following a release of the brakes, demonstrates the value of the reserve emergency braking power which is always available with the Automatic Straight Air brake equipment. This function of the A. S. A. Brake was strikingly demonstrated during a standing test preceding the run of July 4. Following a release after a full service application, with the brakes operating in quick release, the brake valve was moved immediately from the release to the emergency position. The brakes toward the front of the train had fully released before the emergency started, and an examination of the trainograph records showed that the emergency action overtook the release at the 73rd car. The emergency action on the remainder of the cars was not preceded by a release of the service application.

Lack of control immediately following a release from a

service application is a frequent cause of accidents under such conditions, for instance, as entering a yard in a fog, or an unexpected change in signal indications.

One of the serious difficulties encountered in the operation of heavy trains down long steep gradients is the excessive temperatures produced in the wheels and brake shoes. This is due to two causes: First, the inequality of braking efforts obtained throughout the length of a long train, resulting in the conversion of an excessive amount of energy at the wheels of the cars toward the front of the train and, second, due to the comparatively short time available for the conversion and dissipation of the heat generated under the cycling method of brake operation. It is evident that given the same weight of train and average rate of speed, the aggregate amount of energy which must be converted into heat and dissipated remains the same, irrespective of the method of brake manipulation. The nearer uniform the speed remains, however, the lower will be the maximum rate of heat conversion and, therefore, the lower the temperature is maintained in the wheels and brake shoes. Brake burned wheel treads and excessive brake shoe wear are responsible for the destruction of a large amount of material from which is obtained no return in service performed.

The ability to control with certainty under all conditions the maximum trains which may otherwise be operated, removes a limitation to transportation capacity often imposed by long, heavy grades, which otherwise can only be overcome by an extension of facilities.

Another matter worthy of careful consideration is the demands of the brake system on the air pump. With the long trains now operated the quantity of free air which must be compressed is enormous under the best of conditions and the air pump draws heavily on the coal pile. The saving of air effected by the method of braking demonstrated on Kellysville hill is evident. The pump was required to furnish only the air needed to maintain the desired cylinder pressure against train line and cylinder leakage and the comparatively small amount released from the cylinders when reductions of brake cylinder pressure were necessary. This is obviously much less than is required repeatedly to recharge the system following full releases of brake cylinder pressure at from two to three minute intervals with the cycling method of brake operation. When operating in quick release this advantage is lost and the saving in air consumption with the A. S. A. brake is not so pronounced. That there is a saving, however, is evident from a comparison of the volumes which must be recharged following full release after a service application. The service reservoir, which, together with the train line, supplies the brake cylinder, has a volume of 2,100 cu. in. for 10-in. equipment, as compared with 2,800 cu. in. in the auxiliary reservoir, the air in which is not drawn upon during service applications. This difference in volume indicates the extent to which air from the train line is utilized in the brake cylinders.

After a study of the performance of the brakes on the 100-car test trips it seems evident that the Automatic Straight Air Brake performs the functions for which it was designed under everyday service conditions. The economic value of the practical application of these functions it would be difficult to overestimate.

FUSEE POWDER IN A HOT BOX.—A fusee is a mighty dangerous thing to pack a hot box with. This is the text of a circular which has been issued by the safety engineer of the Grand Trunk, to tell of an engineman and a brakeman who used powder taken from fusees to cool hot journals. This is characterized as the latest fashion in getting hurt, a fashion which all employees in Canada are reminded to steer clear of. A fusee contains potassium perchlorate, sulphur, charcoal and a lot of other things that do not get along well together in a hot box.

GUN TRANSPORT CAR FOR THE NAVY

The movement of big guns by rail requires special equipment, which often involves interesting features of construction. A typical example is found in the gun transport car recently delivered to the Navy Department by the Pullman

over the striking castings is 56 ft. When carrying a 16-in. gun the total weight at the breech end will be 165,317 lb. The complete car consists essentially of two flat cars of special design with a bridge placed on them which is arranged to carry the load. The two flat cars on which the bridge is carried are mounted on 70-ton trucks, spaced 10 ft. from

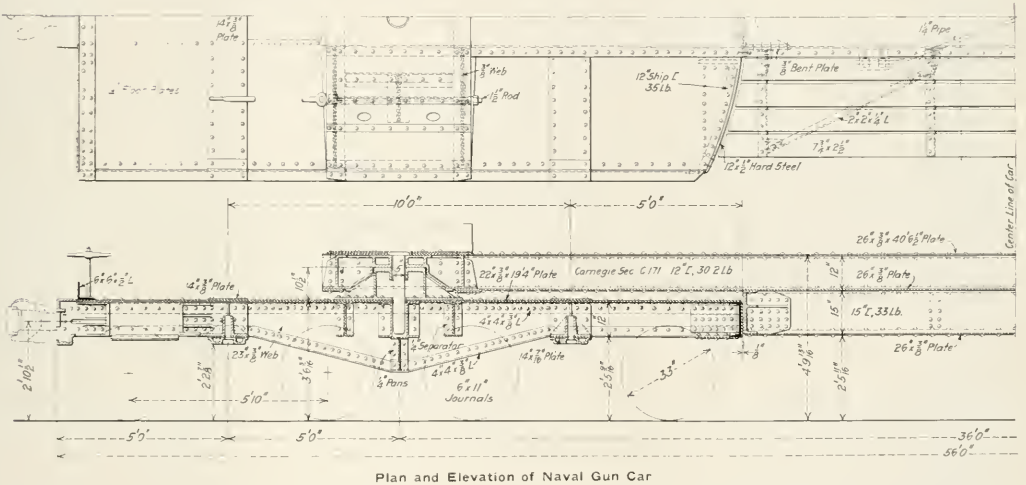
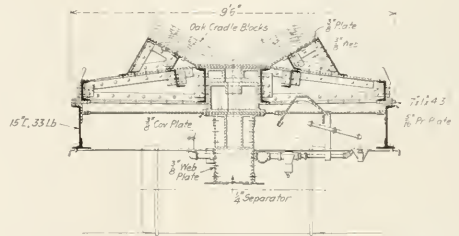
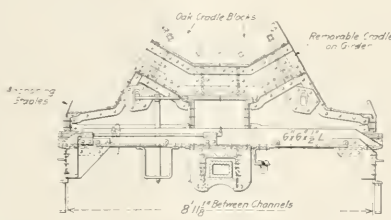

Company. This car is intended to be used for the transportation of the unmounted barrels of navy guns. It is designed to handle 16-in. guns, which are 68 ft. long and weigh 280,135 lb., but can also be used for smaller guns.

center to center. The cars are designed to perform two functions, first to carry the load placed on the auxiliary center plate in the center of the car, and second to transmit the buffing and pulling stresses to the bridge. The center sills

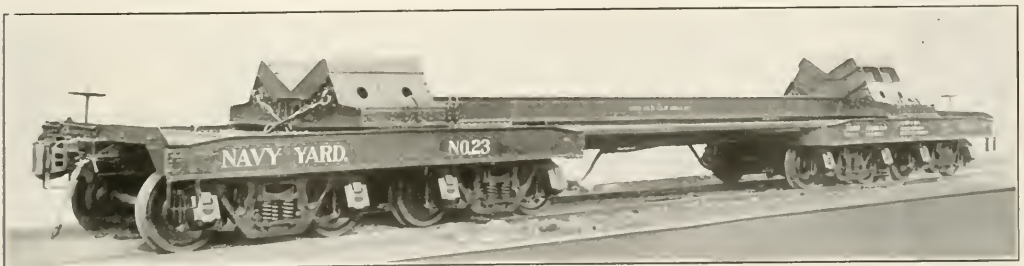

Special Car Designed to Carry 16-Inch Guns

An idler is required when handling 16-in. and 14-in. guns, but smaller guns do not project beyond the ends of the car. The design of the car permits operation over curves as sharp as 100 ft. radius.

The weight of the car complete is 81,000 lb. and the length

are of the fishbelly type 24 1/2 in. deep at the center and 12 in. deep at the bolster, made up of two 3/4-in. web plates. Each web plate has the bottom edge reinforced with two 4-in. by 4-in. by 3/4-in. angles, while at the top edge there is a single angle on the outside of each plate. A cover plate 3/4

in. thick and 22 in. wide extends the entire length of the car. Between the sills at the center of the car there are two pressed steel separators placed back to back. Between these and the cover plate is the auxiliary center plate support. The auxiliary center plate rests on the cover plate and is further

gear and has a straight end sill. The inner end is arranged to transmit the buffing forces to the bridge and the end sill is in the form of an arc of a circle concentric with the auxiliary center plate. This curved end sill is a 12-in., 35-lb. ship channel reinforced by a cover plate and faced on the

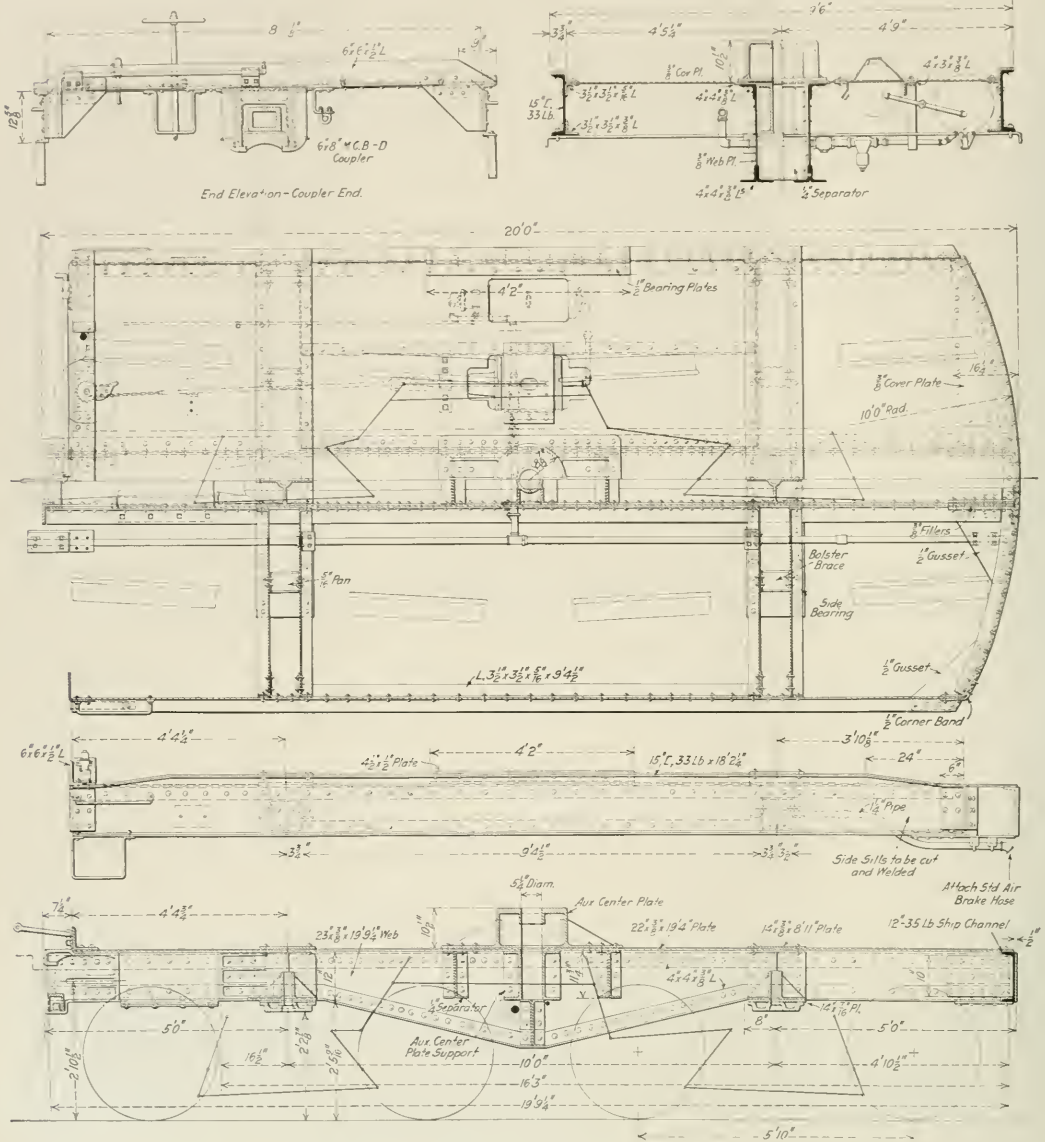

Details of the Carrier Units of the Naval Gun Car

supported on the ends by separators between the web plates. The bolsters are made up of two pressed steel pans spaced 7 in. apart, with fillers above the side bearing, and top and bottom cover plates.

The outer end of the center sill carries the usual draft

outer surface with a 1/2-in. by 12-in. spring steel plate. The end sill is fastened on either side to 15-in., 33-lb. channels, which form the side sills. An angle iron 2 5/8 in. from the top flange forms the support for the deck, which is made of checkered steel plate. Between the bolsters, the side sills are

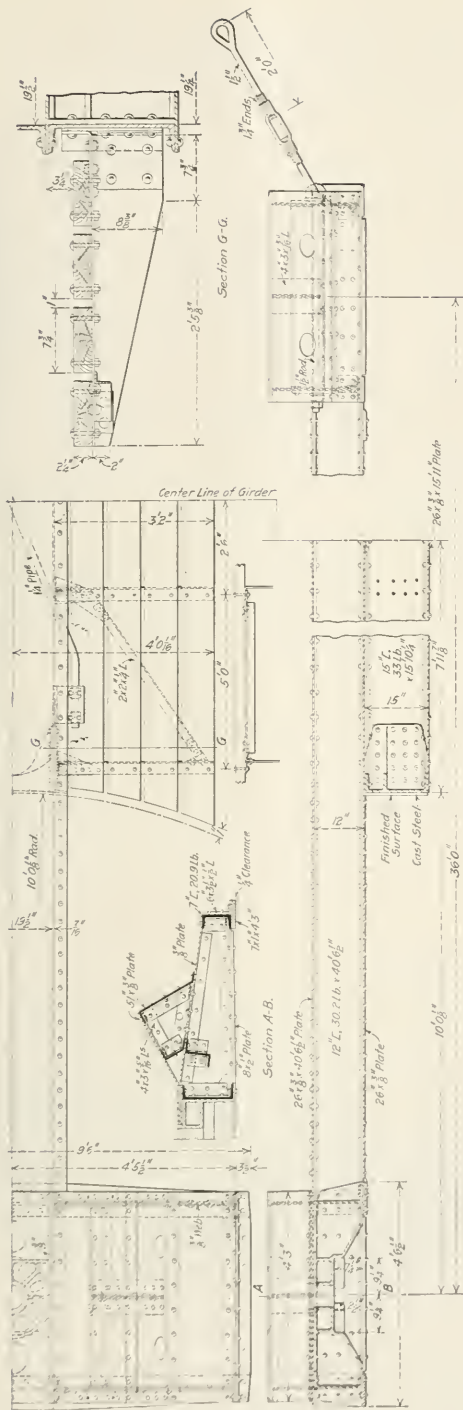

Girder and Buffer Members of 140-Ton Gun Car

further reinforced by an angle iron along the bottom edge.

The bridge has a large steel casting on each end, which fits over the auxiliary center plate. These center castings are spaced 36 ft. from center to center and are joined by a girder made up of two 12-in., 30.2-lb. channels spaced 19 in. apart with the top and bottom cover plates 26 in. wide and 3/8 in. thick. Under the center portion of the girder is a buffing member which is in line with the underframes of the flat cars. The buffing member consists of two 15-in., 33-lb. channels with a bottom cover plate 3/8 in. thick. At each end of the channels there is a buffer casting which is curved to fit the end sills of the flat car. The lower buffer member carries four brackets on each side, which serve as supports for running boards. The buffer member is designed to remove the buffing stresses from the upper girders and the center plate, and to insure that the stresses will be transmitted to the lower member the auxiliary center plates are given a longitudinal clearance of 1/2 in. in the center castings.

The end of the girder member carries two cradles which extend to the side sills and resist the tendency of the bridge to tilt. The center portion is formed of a V-shaped cradle in which the gun rests. At the end which carries the breech, heavy timbers are used for blocking. At the muzzle end, where the support must be higher than at the breech, a removable cradle built up of structural steel is provided. Two 1 1/2-in. eye bolts pass through each cradle and provide a means for fastening the gun to prevent any longitudinal movement.

Each of the two flat cars has a separate braking system and the train line is carried under the buffing member and connected to the trucks by the usual standard M. C. B. air hose.

INSTRUCTIONS RELATING TO CAR REPAIRS

The Committee on Standards for Cars and Locomotives at its meeting at Washington the latter part of the month decided upon a plan for fixing a maximum amount which is not to be exceeded in making repairs to freight cars, depending upon the age, type and class of cars. Freight cars in need of general repairs will be thoroughly inspected, all defective parts noted and an estimate made showing the cost to place the car in general condition for two years' service, barring accident and running repairs. A circular will be issued by the division of operation prescribing the limits of cost for making repairs approximately as follows:

Wooden freight cars which have not been rebuilt and improved by application of metal draft arms extending beyond body bolster, continuous steel draft arms, steel center sills or steel underframe:

(A) In service 20 years or more:

	Limit of cost of repairs in kind, labor and material
All freight cars	
If equipped with 40,000 lb. capacity trucks or less.....	\$25
Over 40,000 lb., but less than 60,000 lb. capacity.....	75
60,000 lb. capacity trucks and over.....	100

(B) Cars in service 10 years and less than 20 years:

	Limit cost of repairs			
	In kind		With betterments	
	No. of reifr.	Reifr.	All cars except reifr. No	Reifr. No
Equipped with 40,000 lb. capacity trucks or less	\$ 5	\$10	Betterments to be applied \$1,000	Betterments to be applied \$1,300
Over 40,000 lb., but less than 60,000 lb. capacity.....	100	150		
60,000 lb. capacity and over.....	150	200		

Cars in service over 5 years and less than 10 years, and cars found equipped with metal draft arms extending beyond body bolster, continuous steel draft arms, transom draft gear, steel center sills or all steel underframe:

All cars, having trucks 60,000 lb. capacity and over, will

be repaired unless total cost of repairs, including cost of betterments, plus scrap value, exceeds 75 per cent of the value of a new car.

If cost of repairs exceeds 75 per cent of the value of a new car, it will be dismantled and good parts reclaimed for use in repairing cars of similar types. This will apply to existing equipment *only*.

Cars in service 5 years and less:

All cars, having trucks 60,000 lb. capacity and over will be thoroughly repaired at cost necessary.

Cost of application of safety appliances, wheels, journal bearings and couplers will not be considered in the estimate of the cost of repairs.

All wooden freight cars with trucks of 60,000 lb. capacity and over receiving general repairs, not equipped with metal draft arm extending beyond body bolster, steel draft arms extending full length of car, steel center sills or steel underframe, will be equipped. Where equipped with steel center sills, a continuous cover plate will be riveted to the top of the sills.

When cost of repairs in kind exceeds the amount allotted to be expended and betterments are not to be applied, the car will be dismantled. Should cost of repairs in kind exceed the amount allotted and betterments are to be applied, if material is not available car may be sent to owners.

When cars are dismantled or sent home to owners for rebuilding a detailed statement will be made showing the estimated cost of repairs in kind by items, and forwarded to owners showing disposition, and copy retained by handling company.

To estimate the detailed cost of repairs 35 per cent should be added to the sum of applied labor and material.

STANDARDIZATION OF PASSENGER CARS

Plans for the standardization of passenger coaches and baggage cars were also discussed at the meeting of the mechanical committee, and subcommittees were appointed for the purpose of reporting on proposed designs. Individual members of the committees were assigned various phases of the designs for study to be reported at the meeting of the committee next month and recommendations will be made as to proposed standard dimensions. A sub-committee was also appointed to investigate the subject of driving-boxes for locomotives.

REGIONAL INSTRUCTIONS

The matter of car repairs has also received the attention of the regional directors. During July the following circulars relating to car repairs were among those issued in the western regions.

Car Repair Shops.—In circular No. 20, dated July 13, B. F. Bush, regional director of the Southwestern region, called attention to the fact that some roads are working their car repair shops less than 60 hours per week and quoted from a letter from Frank McManamy, assistant director, mechanical department, division of operation, instructing that the hours of freight car repair on all lines and in all shops where work can be furnished them should be increased to 60 hours per week and more if practicable.

Building Refrigerator Cars in Company Shops.—In inquiry No. 2, dated July 9, the regional director of northwestern railroads asked the lines in his territory to advise him of the number of refrigerator cars that can be built and rebuilt at each of their shops without interfering with other necessary car repair work.

Cars With Short Draft Timbers.—In inquiry No. 1, dated July 9, the regional director of northwestern railroads asked the lines under his jurisdiction to advise him of the number of wooden cars owned by each road which are equipped with draft timbers extending only to the body sill, secured to draft sills by bolts, showing the total number, separated by

class and capacity. If arrangements have been made to dispense with the use of such draft timbers the roads were asked to advise what will be substituted for them.

Cars Damaged by Switching.—The regional director of central western railroads has quoted a letter from the Car Repair Section of the division of operation of the Railroad Administration, which points out that an increasing number of freight cars are being damaged by switching crews, and urges that special men be placed in transportation yards to check up the rough handling of equipment in order to place responsibility so that necessary corrective measures may be taken. By reducing the number of damaged cars in switching yards a reduction is effected in the number of cars placed on shop tracks, thereby assisting materially in making men available for repairs to equipment becoming defective from other causes and making more cars available for service. The regional director asked that the lines under his jurisdiction take the steps suggested by the Car Repair section of the Railroad Administration.

Responsibility for Car Repairs.—The following instructions have been sent out by the regional directors in the various regions:

Each railroad is responsible for the condition of all cars on its lines, and must give to all equal care as to inspection and repairs. When material standard to the car is not readily obtainable, suitable material of equal strength that is not standard to the car may be used, and the use of such non-standard material will not constitute wrong repairs. When using such material, changes that will prevent standard material from being used in future repairs should be avoided as far as practicable. Railroads are responsible for damage done by unfair usage, derailment or accident to any car they handle, and must make proper repairs at their own expense.

CUTTING THE COST OF EXTERIOR CAR CLEANING

The periodical scrubbing of cars which is necessary in order to take off the dirt that cannot be removed by ordinary washing, is usually done by hand. Even where the best facilities are provided the work is tedious and the operation is expensive. With a view to reducing the cost of this work, the Illinois Central recently made some experiments in the use of power driven brushes. The methods which have been de-

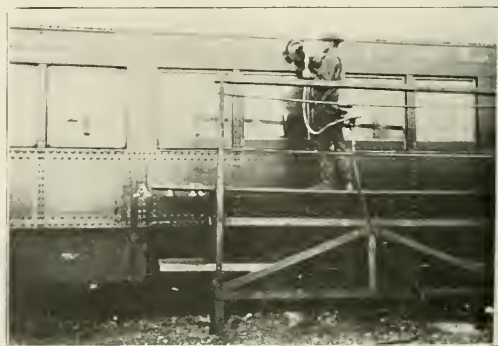

Cleaning Letter Board with Power Driven Brush

veloped have resulted in a reduction of 50 per cent in the cost of cleaning cars as compared with the cost under the former practice.

The illustrations accompanying this article show clearly the method of using the device. The first experiments were

made with a circular brush attached directly to a small reversible air motor. On account of the weight of the machine, the brush was hard to handle and the operator soon became tired. Counterweights were tried, but proved clumsy and inconvenient. It was then decided to try a flexible shaft and since a shaft was procured that would transmit power when driven in either direction the results obtained have been very satisfactory.

The arrangement in use at present consists of an air motor arranged so that it can be suspended from a horizontal rod on a scaffold and attached to a round brush by a flexible shaft about six feet long. The air motor used on this work is the Thor B W type with special gearing, arranged to run at a speed of about 900 revolutions per minute. It is essential that a reversing motor be used as it prolongs the life of the brush very greatly. It would probably be better to have the brush driven at somewhat higher speed, say 1,200 rev-

olutions per minute. In places where compressed air is not available an electric motor would no doubt prove equally well adapted for driving the brush.

In cleaning along the top of the car the operator stands on a scaffold, while the space under the windows can easily be reached from the ground.

The comparative cost of a thorough cleaning of cars before and since the introduction of the power driven brush are as follows:

Cleaning by hand		
Labor	\$8.58	
Material	4.35	
Total		\$12.93
Cleaning by power		
Labor	\$3.00	
Material	2.73	
Total		6.63
Net saving		\$6.30

The first cost of the apparatus is small and the incidental expenses for brushes and power are negligible as compared with the saving effected.

EFFICIENCY IN THE CAR DEPARTMENT

BY W. K. WILMOTT

Efficiency in the car department depends upon the personnel of the department, the organization, the use of modern tools and machinery, and the making of car betterments.

The master car builder or supervisor should be a man with practical experience in car matters with jurisdiction and general supervision over all car shops and car department men. As head officer he will pass final judgment upon all questions relating to car inspection, car repairs, car shop equipment, car repair department billing, and other car department matters.

From among men with special qualifications, the supervisor of the car department may appoint a number of travelers, who will visit all repair points on the line and instruct others in the best practices and improve their efficiency. Among these appointees may be a traveling car foreman, traveling car inspector, traveling car clerk, traveling bill clerk, etc. These men should personally investigate all matters assigned to them by the head car department officer, as well as give general instructions to those on the line pertaining to car matters. For instance, the traveling car foreman may inspect all car shops from time to time, and instruct local car foremen wherever his experience dictates. Stations that render repair cards improperly should be instructed by the traveling bill clerk. Car repairs, in fact, are so voluminous today, that more expert supervision is required, especially at the outside repair points, and this is accomplished by increasing the personnel of the car department supervising organization, as mentioned above.

Organization is a great thing. With the personnel of a department up to a high standard, the head of the car department may appoint a gang foreman over every ten or twenty men, with the view of promoting this man to a higher position when an occasion arises. The probability of promotions, in the car department, is an incentive for men to work for something better. Without encouragement, hope of promotion, and the probability of more wages, it is difficult to retain workmen of much worth in the car department. A common condition or complaint is that some of the needed men have quit, and this is sometimes due to improper organization.

The need of modern tools and machinery have been overlooked on some railroads, but with the cost of labor as high

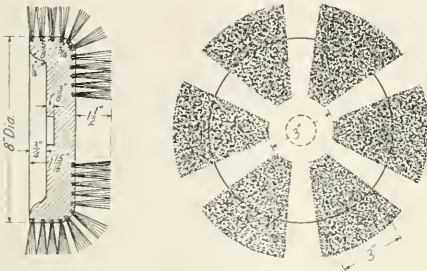

Rotary Brush Used for Car Cleaning

olutions per minute. In places where compressed air is not available an electric motor would no doubt prove equally well adapted for driving the brush.

The brushes used in cleaning the cars are made especially for this purpose in the company's shop. The back is of poplar wood 8 in. in diameter. The holes in which the tufts of bristles are set are 1/4 in. in diameter and are spaced about 3/8 in. from center to center. The spacing of the holes is laid out on a sheet metal templet which is placed over the wood back and serves as a guide when the holes are drilled. The bristles are of capitol Tampico and project about an inch and a half from the back. Each tuft is held in place by a wire staple driven in the hole and is further secured by setting in glue. The proper shape and size of the brush are important. The flat surface should not be so large that the motor is slowed down when it is pressed on the work and the edge must be designed to reach into the corners. By alternating the direction of drive, at suitable intervals when in use, these brushes can be used on a large number of cars before they are worn out. The cost of making them is less than one dollar each.

The flexible shaft is attached to the back of the brush by a small plate held on with screws, the nut which holds the plate to the driving shaft being set in the recess in the brush. In order to reduce the torsional force on the handle, a ball thrust bearing is placed between the handle and the plate. The handle is a piece of steel tubing which is soldered to the casing of the flexible shaft. The other end of the casing is screwed onto the air motor gear case. As the shaft is bent, its length changes slightly, so it is necessary to provide end play in the connection between the shaft and the motor. This is accomplished by drilling a straight hole in the motor spindle and setting a segment in with screws. The tail piece of the flexible shaft which extends into the spindle is made flat on one side so that it will fit the shape of the opening in the motor spindle.

as it is at the present time it pays to use good tools. Drop puts, overhead cranes, electrically driven saws and hand tools, planing machines, etc., are necessary in handling general car repairs. Machinery soon pays for itself where there is plenty of work to do, and there should be no fear of car departments running short of work with the large amount of business being handled. But the heavy work should be concentrated at the nearest large shop or division shop. The smaller stations should make only ordinary running repairs, while the main shops should do the heavy work.

Wrong repairs or improper repairs is a feature to which most railroads are giving more attention than formerly. The company that makes wrong repairs does its work for nothing, for even though the repairs made are billed, the foreign owner seeks defect card protection in correcting the wrong repairs when the car returns home. Car inspectors are closely inspecting their road's equipment when cars return home, obtaining joint evidence statements for wrong repairs and demanding defect cards from the roads that did the work improperly. Car men of mature judgment avoid making wrong repairs to foreign equipment and are alert in obtaining joint evidence for wrong repairs on the cars belonging to their own road.

Car department apprentices are none too many. There are many young men who might make a success as car repairers. The principal requirement is that they be able-bodied and of some education. These young men, however, cannot well displace the older car men, for the reason that mature judgment in car matters comes only from *experience*, with the result that the longer the experience of a car man the more he knows.

Metal work, of late years, has become a matter of car repairs, with car departments having little equipment for handling it. Main shops should be equipped with riveting machines, and other machines for straightening metal car sides or ends, steel underframes, etc. Much work of this kind is now being handled by the locomotive department smithshop by workmen inexperienced in car matters. Inasmuch as car repairs now includes metal work, as well as wood work, it is necessary to provide the car department

with additional equipment to handle this class of work.

A very improper thing among experts, especially traveling car department men, is the limited authority with which they are clothed, it being required in some cases that they locate bad conditions and report them, while as a matter of efficiency they ought to be authorized to correct adverse conditions while on the ground. Of course, this requires the employment of experts who are well drilled. To read a long report of adverse conditions, then have to go all over the ground with a view of making the required betterments, is a slow way of getting action in these modern days. The man who can go out on the line and put everything aright while he is there is the man the supervisor of the car department should add to his personnel, whether he be traveling foreman, inspector, car clerk or bill clerk. Of course, these men may occasionally find conditions which are necessary to report, rather than to correct, but the general tendency ought to be for the traveler to report that which he has corrected, instead of reporting to the head officer what he found.

Car repair billing is today a big item. It requires much supervision to have it done correctly, but by placing it under one head it can be handled authoritatively. The car department may mark the repair cards, showing the car repair charges for each individual car. It matters little who makes the bill or adds or verifies the charges. When outside stations send in repair cards that are improperly rendered, the car department should hand them to the traveling bill clerk who will instruct the car shop clerks regarding the rendering of repair cards.

Next to freight and passenger revenue comes car department billing. Nothing is thought of paying high wages to passenger and freight department men, but if the repairs of a car do not check with the labor cost, there is sometimes much ado, notwithstanding that even good car repairers are scarce at this rate.

Improve the efficiency of the car department by appointing an efficient staff, devise new ways of organization such as may be needed, and put experts over those holding regular positions, with the view of increasing the efficiency of the car department to its limit.



The First Standard 55-Ton Hopper Car to be Completed for the United States Railroad Administration Just Delivered by the American Car & Foundry Company; These Cars Will be Lettered with the Name of the Railroad to Which They Are Assigned



SHOP PRACTICE



MAIN AND SIDE RODS

BY F. G. LISTER

Mechanical Engineer, El Paso & Southwestern

The El Paso & Southwestern has put into use a number of changes in locomotive main and side rods, which have met with good results.

On power originally equipped with strap back end main

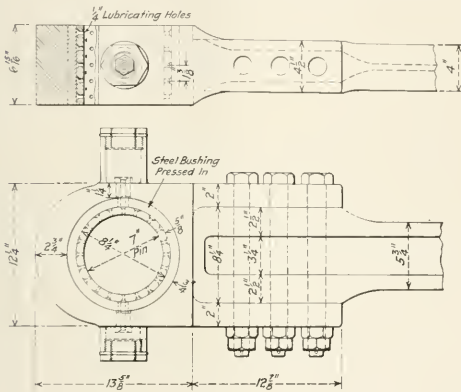

Fig. 1—Detail of Solid Butt End Arrangement

rods, the strap has been replaced by a solid strap end bored out and fitted with a steel bushing pressed in, as shown in Fig. 1. The steel bushing contains a floating bronze liner, or bushing, which is free to revolve, and is a running fit

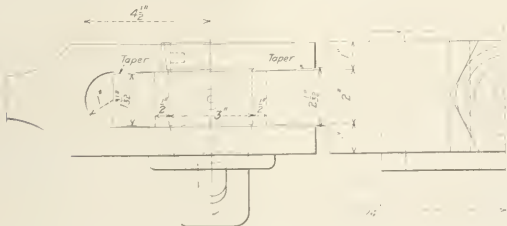

Fig. 2—Lateral Side Rod Strain Relieved by Tapering Tongue and Groove

on the crank pin. This bushing contains a number of 1/4-in. holes for the free distribution of grease.

After a satisfactory trial it was decided to apply the idea to some heavy Mikado type locomotives built by the American Locomotive Company in 1916, and to ten Pacific type passenger locomotives built by the same company in the

early part of 1917. The main rod back end on these locomotives is an integral part of the rod, no bolts being necessary, and the arrangement of steel bushing and bronze liner being the same as in Fig. 1.

The sectional brasses ordinarily applied to main rod back ends are very heavy, and with the high cost of brass, together with the cost of machining and fitting the brasses, liners and keys, the job becomes very expensive.

The bushing can be turned, bored, and fitted in about one-fourth the time required to fit up the sectional brasses. The amount of brass is materially less, and the floating or revolving action of the liner, or bushing, prevents excessive wear. These bushings average about 40,000 miles for passenger engines and 44,000 miles for freight. The idea was derived from a similar design of main rod in use on the Chesapeake & Ohio, and illustrated in the Railway Age Gazette, Mechanical Edition, of April, 1915.

Experiments have also been made on the main rod front end stub. When necessary to renew a main rod, instead of

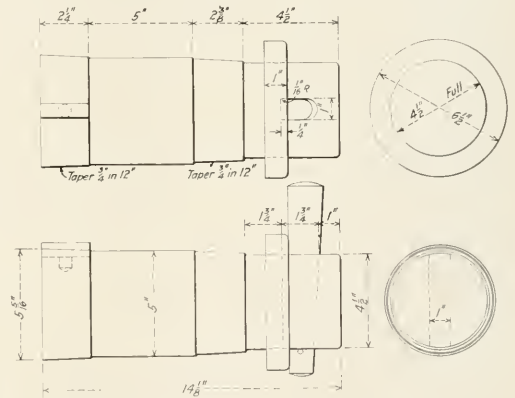

Fig. 3—Arrangement of Wrist Pin Washer and Taper Key

milling out the front stub for the sectional brasses, liner and key, it has been bored out 3/4 in. larger in diameter than the wrist pin and fitted with a bronze bushing 3/8 in. to 1/2 in. thick.

Unnecessary adjustments by roundhouse men, engine inspectors, and engineers is thus eliminated, and galling of the rod in the cross-head is prevented. If excessive wear develops, it is an inexpensive operation to remove the bushing and replace it with a new one.

The lateral strain in side rod connections has been relieved by tapering the rod jaw and tongue, as shown in Fig. 2.

Knuckle pin and wrist pin washers and double nuts have been replaced by washers and taper keys similar to the one

illustrated in Fig. 3. This arrangement has given no trouble whatever, and is believed to possess important advantages over the older method because of decreased cost and greater ease of maintenance.

THE SHORTAGE OF TIN

George Armsby, chief of the Tin Section of the War Industries Board, on May 29 issued a circular to users of babbitt and other bearing metals, solder and tin alloy products, calling attention to the necessity of husbanding the resources of tin on account of the limited supply available. This may be done by eliminating waste, substituting other metals wherever practicable, reducing the percentage of tin used in various alloys and by recovering larger quantities. The War Industries Board has conferred recently with representative manufacturers of babbitt and other bearing metals, solder and miscellaneous tin alloy products for the purpose of explaining the present situation and in order to obtain suggestions as to the most practicable methods for conserving tin. In co-operation with the Bureau of Standards a number of experiments have been conducted, and circular reports of the findings resulting from the experiments and from inquiries made among a number of large manufacturers and consumers have been sent out. All users of the materials referred to are asked to give their full co-operation. The suggestions of the Bureau of Standards for the conservation of tin include several formulae for babbitt mixture for various purposes in which other metals are substituted in order to reduce the tin content and it has shown that while certain types of bearings require a very high grade of lining, others in which the requirements are less severe may contain smaller proportions of tin and a greater percentage of lead or zinc. It is stated that one large manufacturer of machine tools does not use lined bearings at all, believing that bronze alone is sufficient. The part of the circular referring to babbitt and other bearing metals is as follows:

Many specifications for bearing metals now in existence call for virgin tin (Banca or Straits). A large saving of these high grades of tin could be brought about by allowing the use of second quality pig tin in making tin-base babbitt. Detrimental impurities could still be limited, but lead could be allowed to a maximum of one per cent. This would not be harmful in any way to a tin-base or lead-base lining metal.

There is no question that the tin content can be reduced somewhat in all bearing alloys. In a few cases, such as for airplanes, crank-shaft bearings, etc., it may not be feasible to reduce the tin content by any but a small percentage, whereas in other cases it can be cut down very considerably. In the present emergency every possible saving, however small, should be effected.

For those cases where genuine babbitt is now used and which require a very high grade of lining, alloys such as those given in columns 1 to 4 inclusive, of Table I, are suggested.

TABLE I—PER CENT COMPOSITION OF BEARING METALS

Tin	1	2	3	4	5	6
Antimony	85	84	65	62	8	5
Copper	10	8	8	7
Lead	5	8	3 to 6	4	4	2
Zinc	28 to 30	33	80	10
Aluminum	1

One large bearing metal manufacturing concern states that the tin should be reduced in favor of lead. Lead-base linings can be used in many cases where tin-base linings are now used, and in general are just as satisfactory. Many manufacturers already use the lead-base metals, but their use could be made more universal. Several special types of lead-base linings, hardened with alkali or alkali earth, are

reported to be giving very satisfactory service in the place of high tin babbitt.

One firm states that it is using the substitute compositions given in columns 5 and 6, Table I, instead of those given in columns 2 and 3, in order to conserve tin. These have apparently been found to do the service required of the tin-base linings in machine tool work.

Another large manufacturer of machine tools does not use lined bearings at all, believing that bronze alone is sufficient. There is probably no question, however, that the lined bearing is cheaper because of the less amount of machining necessary in making the bearing. It is also claimed that the cost of replacement of a lined bearing is less than that of a bronze bearing and has to be made less frequently. One way in which lining metal can be saved is to use just as thin a lining as it is possible to have in order to maintain a high enough temperature during pouring to insure a firm bond and solid mass of metal.

In place of a bronze used for bearings containing 80 per cent copper, 10 per cent tin and 10 per cent lead, the alloys given in Table II might be substituted as having been thoroughly tried and found satisfactory.

TABLE II—PER CENT COMPOSITION OF BRONZE BEARINGS

Copper	7	8	9	10	11	12
Tin	81	79	74	64	Remainder	Remainder
Lead	7	5	5	2	8	5
Zinc	3	13	20	2	15	17½
Antimony	1½ to 3	5
Phosphor per cent	..	1	1

With the co-operation of all, in consideration of the above suggestions, it seems probable that much less tin could be used in bearing metals without in any way impairing their service. It is believed that a saving of at least 25 per cent could be brought about by a judicious selection of the proper composition of either bronze or lining to use for each particular service and by insisting upon its use.

DEFINITIONS OF TERMS USED IN AIR COMPRESSOR RATING

Upon the recommendation of its Technical Committee the Compressed Air Society has adopted the following definitions of certain compressed air terms in order to eliminate confusion as to their exact meaning.

Displacement.—The displacement of an air compressor is the volume displacement of the net area of the piston.

Capacity.—The capacity should be expressed in cubic feet per minute and is the actual amount of air compressed and delivered, expressed in free air at intake temperature and at the pressure of dry air at the suction.

Volumetric Efficiency.—Volumetric efficiency is the ratio of the capacity to the displacement of the compressor, all as defined above.

Compression Efficiency.—Compression efficiency is the ratio of the work required to compress isothermally all the air delivered by an air compressor to the work actually done within the compressor cylinder as shown by indicator cards, and may be expressed as the product of the volumetric efficiency, the intake pressure and the hyperbolic logarithm of the ratio of compression, divided by the indicated mean effective pressure within the air cylinder or cylinders.

Mechanical Efficiency.—Mechanical efficiency is the ratio of the air indicated horsepower to the steam indicated horsepower in the case of a steam driven, and to the brake horsepower in the case of a power driven machine.

Overall Efficiency.—Overall efficiency is the product of the compression efficiency and the mechanical efficiency.

The society, which is composed of air compressor manufacturers, recommends that the use of other expressions of efficiency be discontinued.

BOLT MANUFACTURE IN RAILWAY SHOPS

A Consideration of Methods and Tools Necessary for the Rapid Production of Bolts in Railway Shops

BY M. H. WILLIAMS

RAILWAYS are large users of bolts and rivets, of practically all sizes and shapes, and this endless variety has made it necessary to go into their manufacture more with the object of meeting demands for odd sizes than to effect a saving as compared with their purchase.

The required bolts and rivets can be made on the following machines: Hammer heading machines, bolt heading or forging machines, automatic feed bolt machines, and cold heading machines. The threading of bolts can be done on the regular bolt threaders or on thread rolling machines. In



Fig. 1—Cutting-off Arrangement

some shops a number of bolts are finished on lathes, bolt skimming machines and automatic screw machines. The latter, covering the turning of finished or taper bolts, will not be considered.

Bolt heading machines are generally well known in the railway shop, therefore only a brief description will be given of each type. More attention will be given to the subject of tools and rate of production, to enable those who have not had an opportunity to look carefully into the various classes of machines to form an opinion of their relative value for their particular requirements.

Hammer Headers—One of the older designs of bolt heading machine on which the finest quality of bolts may be made is the hammer header. It has the customary horizontal moving ram, operated from the crank shaft, which carries the die for forming the top of the bolt head. Two vertical and two horizontal moving rams are operated by toggles to form the sides of the bolt head. The gripping dies to holding the body of the bolt, also are operated by toggle action.

When manufacturing bolts on this type of machine it was customary to cut the blanks to the proper length previous to heading. However, some of the later machines are arranged to cut the blank when heading, the latter operation being confined to relatively short lengths. The sequence of operation is as follows: The operator places the heated blank between the two gripping dies with the rear end against a stop. The lever is pulled that causes the gripping dies to close on the blank. A second lever is pulled that sets the various heading rams in operation. The main horizontal ram moves forward and the heading die upsets the end of the blank. Next, the horizontal ram dies strike the sides of the bolt head, and a moment later the vertical dies strike the bolt head. This operation is repeated as many times as is considered necessary in order to produce a satisfactory head, the first one or two blows working the metal only into a rough resemblance of a bolt head, the repeated blows forming the finished head. After the head is formed

the starting levers are released and the finished bolt is removed by the operator.

To reduce labor and increase output, a later type of machine has been designed known as the semi-automatic hammer header. This machine is similar to the one referred to above, with the addition of a cam motion that automatically closes the gripping dies, moves the stop for the rods back of the gripping dies at the right moment, and governs the number of strokes of the various heading tools. With this design of machine it is only necessary for the operator to place the blanks in the machine, the cams attending to closing the gripping dies and all other operations. When the head is completed, the bolt falls into a receptacle below the machine. The operator is not required to remove the finished bolt from the machine or operate levers and can devote his entire time to feeding the blanks. The cams and the speed of the main shaft govern the theoretical output and with a good operator and heater, the output will be from 6,000 to 10,000 bolts per day.

Some of these later semi-automatic hammer headers are also arranged to cut the heated stock to the correct length, this being done by a shear blade attached to one of the gripping dies. This arrangement is shown in Fig. 1, A and A' being the gripping dies, B the shear and C a stop to govern the length of rod that may be fed. The dies are shown in the open position. As the gripping dies close, the heated stock is cut off between the shear blade B and the die A' . The stock is then carried along and firmly held in the gripping dies. The stop C is controlled by cam motion, being in front of the opening in the dies when the latter are open and out of the way when closed.

When operating this class of machine with the shearing device, it is customary to heat from two to four feet of bolt stock and feed it to the machine. As each bolt is made, the

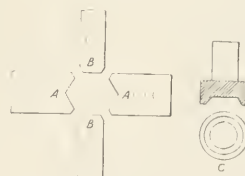

Fig. 2—Heading Dies Used with Hammer Header

stock is advanced, this being continued until the heated portion is made up. Separate lengths of gripping dies A and A' are necessary for each size and length of bolt required.

On any of the hammer heading machines mentioned above excellent bolts may be manufactured and if the blank is given a sufficient number of blows, the corners will be sharp and the heads well formed. Fig. 2 illustrates the form of heading dies employed on the majority of hammer headers, A and A' being the horizontal heading dies, B and B' the vertical dies and C the die for forming the top of the head, which is held in the horizontally moving main ram. The dies A and B are for hexagonal head bolts. For square head bolts the dies A and A' have ends similar to dies B and B' . One set of these dies can often be employed to form two or more sizes of heads.

The header die C can only be used for one size head when bolt heads to correct dimensions are required. These dies are cheap to make and will last a long time. Their manufacture will be taken up later.

Forging Machines or Bolt Headers—This form of machine is used very extensively in railway shops and bolt making concerns for the manufacture of bolts, rivets and a large number of other forgings. For the general miscellaneous work required, it is a question if any machine is better adapted for the purpose. For making bolts and rivets in large quantities, some of the faster machines which will be described later, can often be used to good advantage to take care of the large orders, making use of the above machine for the smaller lots.

The bolt forging machine has the customary horizontal moving ram or header in which the heading dies are held. This is operated by crank motion from the main shaft of the machine. A side ram or slide is also operated by toggles or wedge motion, on which one of the gripping dies is held; the opposite gripping die is stationary. A stop is located back of the gripping dies for the purpose of gaging the length of rod that may be fed. This stop is controlled by cam motion so that as soon as the gripping dies close, the stop raises out of the way before the main header die reaches the bolt blank. A face plate is located in front of the gripping dies and arranged to hold bushings slightly larger than the stock used for making the bolts. This also acts as one blade of the shear for cutting off the stock. A second hole is located in this face plate for the kicker pin that ejects the bolt or rivet when completed.

For making articles that can be headed by one blow it is customary to heat from two to four feet of stock. The heated stock is then passed through the bushing hole in the face plate and onward against the stop. The movable gripping die then advances and cuts off the stock between the die and bushing. The blank is carried along by the movable die and later gripped between the two dies. The header ram and die then advances and forms the head of the bolt or rivet. As the gripping dies open, the kicker pin ejects the finished article which falls through the side of the machine into a pan. After one piece is completed the stock is advanced and the operation repeated until the heated portion is used up. Another rod is then treated in the same manner. By this method a large output may be obtained of bolts or rivets coming within the range of single blow heading. The machines are generally belted to strike from 60 to 90 blows per minute and make a piece at each stroke. The output per day is largely governed by the ability of the operator to feed the stock and take advantage of as many strokes as possible. As the blank is cut off in the gripping dies, it is necessary to provide a separate set for each length and diameter of bolt or rivet manufactured.

This method is limited to simple articles having small heads, such as rivets, track bolts and a few small headed bolts. The amount of stock that may be gathered in one blow generally cannot exceed in length over $2\frac{1}{2}$ diameters. For hexagon or square headed bolts, it is customary to use gripping dies having two or more impressions or passes, the first being largely for gathering the metal, and the second to form the finished bolt. The header ram also has a similar number of dies.

In operation the bolt stock is cut to the required length. Each piece is heated at one end and placed between the two gripping dies. For large bolts a back stop is used to prevent the blank from moving backward when hit by the header die. The treadle is pressed which sets the machine in operation and it goes through the regular operations of one or more strokes as may be desired. After this cycle is completed, the partly formed bolt is placed in the second impression and the cycle of operation gone through a second time, and so on. By this method a very good grade of bolt

head may be formed. With proper dies, the bolt heads will show up fairly sharp at the corners but as a general rule are not as well formed or as smooth as those made on hammer headers.

Automatic Continuous Feed Machines—The single blow header with the addition of feed rolls for feeding the stock to the machine eliminates hand feeding and very greatly increases the output. The feed rolls are located in front of the machine in line with the openings in the gripping dies and are rotated with a step-by-step motion by a cam placed on the main shaft. With the automatic machine it is customary to install a special furnace long enough to heat bars of full mill length, generally about 20 ft., directly back of the feed rolls. The furnace is fed from the back, or end away from the machine.

In operation one man is stationed at the back end who feeds the full length of bars to the furnace, the number in the furnace at one time being governed by the time required to heat and the speed of manufacture. This may vary from three bars for small and short work, to eight bars or more for large and long work. As one bar is used up, the furnace man pushes a heated bar forward so that the machine operator can take hold of it with his tongs and enter it into the feed rolls, the end of a new bar being butted against the partly made up bar, so that the operations of heading are practically continuous. As the feed rolls revolve the rod is fed through a quill into the hole in the face plate and onward against the stop gage. The stock is then cut off, headed and ejected the same as on the single blow machine. All the operations of the machine are entirely automatic and

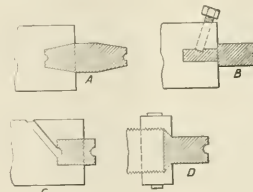

Fig. 3—Methods of Holding Dies

require but little work on the part of the operator. The amount of scrap is small, amounting to only a small piece at the end of each bar.

These machines will produce rivets, track bolts and the simpler forms of bolts at speeds varying from 70 to 100 per minute and when provided with good dies can be kept in operation a large percentage of the time. The metal is heated gradually without the danger of overheating common to heating each blank separately. In actual operation it is not uncommon for this class of machine to operate for several hours at a time, making a bolt or rivet at each stroke or at the rate of 4,000 to 5,000 rivets per hour.

Owing to the great speed with which articles are made in this class of machine, the gripping and header dies and the bushings used in the face plate heat considerably, even with a liberal stream of water directed on them. Unless a very high grade of steel is used for these parts they soon wear or develop hair cracks at the edges, making it necessary to stop the machine frequently to renew dies.

Dies, Tools, Etc., for Hot Heading Machines—The accuracy, finish and grade of steel that best meets the requirements for bolt machines in railway shops is somewhat of a question and must to a large extent be governed by the quantity of any particular size to be made. For bolts or rivets made in large numbers, the best grade of steel and workmanship on the dies will generally prove the more economical in the long run, considering the fact that bolt head-

ing machines are expensive and take up valuable shop room. It would, therefore, appear to be poor economy to delay output for want of dies of the proper grade and finish. The manufacture of bolts or rivets having round bodies without fins makes it necessary to finish the grooves in gripping dies very accurately. Lost motion in the side ram is also often responsible for the product not being up to high standard of shape and finish.

For dies used in the manufacture of bolts or rivets in large quantities the low carbon high speed steel made especially for hot work will generally be found the more economical in the end. The virtue of high speed steel lies in the fact that it retains its wearing qualities at high temperatures such as bolt dies are subjected to. Where this steel

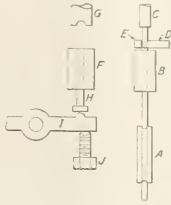

Fig. 4—Cold Heading Machine Arrangement

is used, it should be hardened by the usual method, that is, cooled from about 2,100 deg. F. in an air blast or oil and afterward drawn back to from 600 to 800 deg. The draw back is very essential to prevent breakage and will not affect the wearing qualities of the steel. It will appear soft, however, when tested with a file. The regular high speed steel, such as is used for cutting tools, is too high in carbon for bolt header dies and is liable to crack as a result of the heating. For dies used only occasionally, the cheaper grades of steels or even worn out car axles can be used to good advantage.

Finishing Gripping Dies—The method of machining gripping dies must of necessity vary with the tool room equipment. The ideal method in many respects is to order the steel in blocks about 4 ft. long and of a section such as may be required. These blocks may be planed, milled or ground to the required size and afterwards sawed to the necessary lengths. By using a power hack saw or band saw, the amount of metal wasted in cutting will not be excessive. Two methods can be used for forming the grooves, one being to clamp two die blanks together and drill between the two, and the second, which in many respects is preferable, being to mill the grooves with a convex cutter of the correct radius, a depth gage being used to insure the proper depth. By milling, the grooves can be made equal in each half of the die, which is somewhat difficult by the drilling method. The surface grinder will be found very useful and economical for finishing new gripping dies and also for repairs to worn dies. For new dies they may be roughed out by either of the methods mentioned above. After hardening, or even with soft dies, the flat surfaces can be finished much quicker than by filing. The half round grooves can be finished very quickly and accurately by grinding, employing a grinding wheel that has been formed to the proper radius on its periphery. By setting up two die blocks at one time on a magnetic chuck or by other clamping methods, the grooves in a pair of dies can generally be ground in less than a half hour, including the average amount of grinding necessary to remove hardening roughness, or wear from service on repaired dies. This also includes the time necessary to true the wheel, which should be done previous to the final finishing cut. Where the grooves and surface are finished by grinding, they can be made very accurate and smooth and

the practice will be found economical, due to the fact that worn dies may be resharpened without annealing.

On account of the great variety of shapes of gripping dies, no attempt will be made to explain all the forms employed. It is to be regretted that these have not been standardized.

Header Dies for Single Blow Machines—Several methods are employed for holding heading dies in the horizontal moving ram of bolt heading machines and a few common forms are shown in Fig. 3. That shown at A is double tapered and usually made with an impression for bolt or rivet head on each end, the holder, or ram block, having a tapered hole to receive the die. This design when new and held securely in a well made ram block works very well. It has the disadvantage, however, of being difficult to remove on account of the taper fit wedging into the ram block and in the event of wear of the taper hole in the die block, the dies will not hold properly. To make this form requires a relatively large amount of tool steel and the number of redressings are limited on account of shortening the taper surfaces.

The die shown at B has a straight shank fitting into a hole in the ram block and is secured by a bolt set purposely at an angle in order to force the shoulder of the die firmly against the ram. This die is easy to remove and not difficult to make but requires a large amount of steel and can only be used on one end.

The die shown at C is simple in form, being made from round steel, about three times the diameter of the bolts to be manufactured. The ram block is bored about 1/32 in. larger than the die. The die is made from 3 1/2 in. to 4 in. long originally, and can be refaced several times. As it is shortened, due to refacing, liners are placed back of the die to preserve the original length and avoid altering the location of the ram block in the machine. It is held in the ram block by a set screw. A hole drilled on an angle in the ram block makes it possible to remove the die in the event that it binds from heating or scale lodging between the die and the block. This form has the advantage of requiring a small amount of tool steel; it is easy to remove and can be made with double ends so that as one end becomes worn the second end may be used.

The die shown at D is held on the ram block by a method

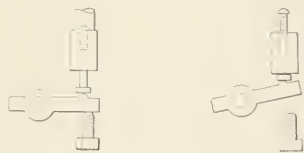

Fig. 5—Forming and Ejecting Operations

similar to that of holding punches in punching presses. It has the advantage of holding very firmly even for complicated or deep heading. It can be removed quickly and in the event of wear or change in length, liners can be placed back of the die. It has the disadvantage of having only a single end and is more expensive to make than the die shown at C.

Past practices or the design of the die ram in existing machines often govern the type of dies employed. In many cases a large number of dies have been made and are on hand and a change in the method of holding and the design of the die will involve considerable expense. However, it is always advisable to make all dies, as far as possible, interchangeable for the various machines. This would indicate that some satisfactory design of die and ram block should be adopted and new dies made to the adopted de-

sign and existing dies altered where possible. As a general proposition the die and ram block as shown at *C* will be found satisfactory for bolts and rivets made on single blow headers, and has the advantage of cheapness.

Where bolts or rivets are manufactured in large quantities it will generally be found desirable to make the heading dies from high speed steel as mentioned above for gripping dies. The continuous service will quickly wear the surfaces unless the best grade of steel is employed.

Face Plate Bushings—When making bolts or rivets on the continuous feed machines, or when hand feeding long heated bars, there will be more or less delay on account of wear of the bushings used in the face plate for shearing the stock, unless the very best grade of steel is employed. Here again high speed steel can be used to good advantage. Also, if good work and large output is desired, these bushings should be ground inside and out after hardening to insure a good fit in the face plate and free passage for the stock.

Cold Heading Process—A number of bolt manufacturing companies make bolts and rivets by the cold heading process which eliminates heating and admits of rapid production at a low labor cost. This method is little used in railway shops but has possibilities for the larger roads having demands for small bolts and rivets in large quantities.

For this class of work the material must be a very soft mild steel, cold drawn and accurate in diameter. When heading, the stock is fed automatically into the machine, and each machine will make from 3,000 to 5,000 bolts or rivets per hour, depending on the style and size of machine employed, one operator attending to several machines. Bolts are upset with heads round in form, the contour being that of a section across the corners of a finished bolt. These are afterwards trimmed hexagon or square as required. The trimming is performed in an automatically fed punching machine at the rate of about 3,000 per hour and with practically no labor other than to shovel blanks into the hopper and keep the tools in order.

The cold headed blanks may be threaded on the customary bolt threader or by thread rolling machines, the latter operation being performed at the rate of about 3,000 per hour, depending largely on the ability of the operator to

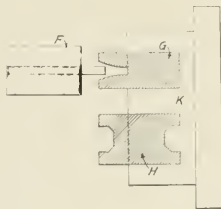

Fig. 6—Double Stroke Heading Dies

feed the machine at the right time. Automatic feeding machines are used mostly on the smaller sizes.

Bolts are generally annealed to remove all strains set up in heading. Rivets intended for driving cold are also annealed. The following description of the process and tools required will assist in forming an opinion of the adaptability of this class of machine for railway work.

Heading Machines—The cold heading machines that have been put on the market by a number of concerns are of very heavy construction and of the highest order of design and finish. On account of their extra strength and weight they cost more than hot heading machines of the same capacity.

The stock from which the bolts or rivets are made is received in bundles similar to telegraph wire, each bundle

weighing from 100 lb. to 200 lb. The bundles are placed on stands in front of the machine. The free end is then fed to a pair of feed rolls, the operations being shown in Fig. 4. The two feed rolls, which are held against the stock by spring tension, are shown at *A*. They are slightly grooved to fit the stock to be headed. As each bolt or rivet is headed, the rolls are rotated sufficiently to feed the required amount of stock which passes through a hardened steel cut-off quill *B*, and onward against stop *C*, in front of shear blade *D* and under the spring finger carrier *E*. The shear blade *D* is made concave to conform to the radius of the stock. The shear blade and feed finger carrier are timed to advance together when the stock strikes stop *C*, cutting off the stock, the cut-off blank being held between the shear

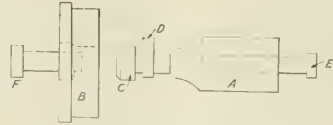

Fig. 7—Dies for Shaping Bolt Heads

blade and the finger. The blank is then carried forward to a position directly in front of the heading die *F*. The heading die which is held in the ram of the machine now advances against the stock and pushes it into the die *F*, the shear blade *D* and finger *E* backing out of the way. The blank continues to advance in die *F* until encountering stop pin *H* which is backed up by stop lever *I* and this in turn by bolt *J*. As the blank is now prevented from going further into the die *F*, a head is formed as shown at the left in Fig. 5. The ram of the machine then backs away and the blank is ejected by the lever *I*, forcing the pin *H* into the die *F*, as shown at the right in Fig. 5. Lever *I* is operated by cams timed with the other operations of the machine. This is what is known as the single stroke solid die header, on which the simpler shapes may be headed by one stroke. Generally speaking, the amount of metal in the head is limited to about $2\frac{3}{4}$ diameters.

For bolts and rivets having large heads it is customary to use what is known as a double stroke header. With this machine the operation of feeding and cutting off the stock is the same as previously explained. Instead of forming the head with one stroke of the ram, the double stroke machine makes two strokes for each piece produced, the ram being arranged to hold two dies *G* and *H*, as shown in Fig. 6, in a vertically moving slide *K*. These operations are controlled by cam motion as follows: The first die *G* strikes the blank and forms a cone head; the slide *K* then moves backward with the main ram of the machine and at the same time is raised so that die *H* is level with the blank; The main ram then advances and forms the head. The blank is finally ejected the same as in the single stroke header. The various operations of feeding the stock and heading the bolts or rivets all take place automatically and without attention other than to keep the tool in order and new stock in the rolls.

The length of bolt or rivet that can be made on this class of machine is limited by the ability of the ejector pin *H* to eject the blank after the head is formed, the maximum length being about seven diameters.

When necessary to make longer articles it is customary to use what is known as the opening die cold heading machine. This is similar to that explained above as far as feeding the stock and the various operations are concerned. In place of the solid round die *F*, a pair of opening dies similar to the gripping dies used in hot heading machines are used. These are opened and closed by the cams forming

part of the machine. On this form of machine the stress on the ejector pin is very much reduced on account of the dies opening partly before the bolt or rivet is thrown out and as a result, articles up to any reasonable length can be made. It is also possible to make a number of odd shaped heads, such as wash bolts that are not practical on the solid die design.

Head Trimming Machines—There are several designs of head trimming machines. One type is arranged with a hopper at the top into which the blanks are shoveled. The blanks are then fed automatically through a chute in front of a horizontal punch. This, as far as handling the blanks is concerned, is an adaptation of the machines used in the manufacture of small wood and machine screws for feeding to the saw or for threading. One form of punch and die used is shown in Fig. 7, in which *A* is the punch made from round tool steel, with a square or hexagon cutting edge. The hole through its center is slightly larger than the bolt body. *B* is the die which is also made from round tool steel. The fitting of the cutting edges of the punch and dies follows the usual practices for punching work. The punch has a gradual taper back from the cutting edge for the purpose of parting or splitting the punchings, which gather up on the punch in rings and gradually drop off as one or more accumulate. An ejector pin *E* is located in the hole in punch *A*, and a second ejector pin *F* in the opening of die *B*. Fig. 7 also shows the end of the feed fingers *D* in position to feed bolt *C* into the punch *A*. In operation the blanks are picked from the hopper chute by fingers *D* and carried to the position shown. The punch then advances partly over the blank when the feed finger *D* lifts out of the way, the blank being now held in the hole in punch *A*. As the punch continues to advance the bolt head is punched to the required shape. The ejector pin *F* in the die then ejects the bolt from the die when the punch has receded. In case the bolt holds in the punch, it is ejected by the pin *E*. The various cams on the machine are timed so that these operations go on automatically in sequence at a rate of about 3,000 per hour.

Thread Rolling—A number of bolts and studs are now threaded by the thread rolling process; that is, the thread is formed by rolling the blank between two dies having grooves cut on their surfaces, corresponding in shape, pitch, and angle to the thread desired. By this method articles can be threaded very much faster than in the customary bolt threading machine. Also, smaller bolt stock can be used.

In order to get a clear understanding of the process of thread rolling, a simple demonstration may be made by taking two pieces of soft pine, free from knots, about 6 in. long and 2 in. square, holding one in a vise. On top of this place at right angles a $\frac{1}{2}$ -in. threaded bolt, then press the second piece of pine on the bolt and move the upper piece back and forth. The soft pine will take the impression of the thread and will give a good illustration of the appearance of a pair of thread rolling dies. It will be noticed that the faces of the wood are grooved similar to the thread on the bolt and that the grooves are on an angle similar to the bolt and both slope in the same direction.

There are several designs of machines and dies used, some making use of dies in circular form. For general bolt work the machines having flat dies are the more common and answer the purpose very well. In these machines one of the dies is held stationary and the other is given a reciprocating motion. Most of the machines for small bolts are arranged for feeding the blanks vertically, either by hand or automatically. For the larger bolts and track bolts a machine having vertically moving dies is generally used. The vertical machines will admit of threading long rods where it is often possible to use stock smaller than the thread size, resulting in quite a saving in metal. That is,

for 1-in. bolts, studs or long rods can be made from stock about 15 to 16 in. diameter, which will have practically the same strength as similar articles made from full sized bars and cut with bolt threading machines.

In thread rolling, the pressure exerted by the rolling dies makes impressions on the blank. At the same time the metal between the sharp edges of the die grooves flows upward. The amount of metal raised above the original surface of the blank about equals the depressions. It then follows that the size of stock for the manufacture of rolled threaded articles about equals the thread pitch diameter. For $\frac{1}{2}$ -in., 13-thread bolts it is customary to use stock .446 in. in diameter; for $\frac{3}{8}$ -in., 16-threads, .331-in. stock; $\frac{1}{4}$ -in., 20-threads, .215-in. stock, etc. The dies for thread rolling are manufactured from carbon tool steel 1. to 1.20 per cent carbon.

In manufacturing the flat dies, the blanks are machined to the required size and the grooves milled on the cutting face to suit the bolt to be rolled. When milling these grooves it is customary to clamp the block on the table of a universal milling machine parallel with the center line of the table. The table is then set to an angle equal to the angle of the thread. This taper is given in inches per foot in literature supplied by the manufacturers so that it is not difficult to properly set the machine.

When rolling a thread, the blank to be cut will revolve one complete turn in a distance equal to the circumference of the stock used. That is, for $\frac{1}{2}$ -in. bolts the diameter of the stock, .446 in., should be considered and not $\frac{1}{2}$ in. Dividing the circumference in inches into 12 will give the number of turns the blank will make in traveling one foot. It is also evident that the thread will advance one thread per turn. By multiplying the pitch distance by 12 and dividing by the circumference of the blank, the amount the table of milling machine should be set over per foot will be obtained. As the tables of universal milling machines are generally graduated for taper in inches per foot, the setting of the proper taper is not a difficult operation.

Separate dies must be made for each thread and diameter. That is, one set of dies cannot be used for 7/16-in. and $\frac{1}{2}$ -in. bolts, even if the number of threads per inch be the same. These dies must be carefully made and also carefully hardened. In practice a set of dies will cut from 200,000 to 500,000 bolts before refacing is necessary. To reface, the dies are annealed and handled the same as new dies.

When setting the dies in the machine it is necessary to adjust them so that the two will track on the thread. This is done by slightly raising or lowering one of the dies and is not a difficult operation. The adjustment for diameter is obtained by adjusting together or apart as may be required. After a set of dies is once properly set, little readjustment is necessary. The output of these machines is limited by the ability of the operator to feed the blanks. A lively boy or girl can readily feed a machine rolling 50 bolts per minute, this being much faster than cutting in a bolt threader and not as fatiguing to the operator.

The cold process of making bolts and rivets has the advantage of cheap production, but requires a very high order of tool room work to properly make and maintain the dies and tools. At least one good machine operator must be employed on a group of machines to keep everything in proper order. The feeding can be looked after by operators having little experience. The tools for making bolts or rivets by the cold heading process must be very exact in regard to size, and highly finished. Referring to Fig. 4, the dies and quills *B*, *F* and *G*, are made of carbon tool steel. The outside after hardening must be ground to a limit of about .001 in. The hole in die *F* must be very carefully lapped or ground and of one diameter for the en-

tire length. Unless this is the case, satisfactory service will not follow. The hole is made .003 to .005 in. larger than the stock to be headed. The heading dies *G* and *H*, Fig. 6, are of similar material. The recess or impression for the head must be correct. It is customary to fit these to a master gage. They must be polished after hardening. When hardening the dies it is necessary to obtain hard surfaces around the hole, which receives most of the wear. This may be obtained when quenching by directing a stream of water through the hole or onto the face of the header dies. All dies should be ground on their ends. The shear blade *D* must be ground on the flat surface after hardening. The dies will often make 100,000 to 300,000 bolts or rivets before requiring regrinding, their life being governed largely by the amount of rust or dirt on the material used. Dies can be made originally for the smaller sizes of bolts or rivets and enlarged for the larger sizes as they wear. As a general proposition the cost of maintaining tools for cold heading is less per 1,000 bolts or rivets than for hot heading. The stock for cold heading must be cold drawn and should be lime coated to prevent rust. The price of this stock varies with market conditions, but is generally cheaper than hot drawn for the smaller sizes. The cold heading method eliminates the use of furnaces for heating the blanks required for hot heading. This is offset somewhat by the necessity of annealing the bolts after heading for the purpose of removing all strains that may be set up by the heading process. But a large number of bolts can be annealed at one time and with a smaller consumption of fuel than is required for hot heading.

Bolts made by the cold process will answer practically all purposes except where it is necessary to have a tight fitting bolt. For ash pans, air brake hose, jackets and a number of places they answer all requirements. The principal argument in favor of the cold heading method is low cost, large production per man, the small shop space required and the superior product. With the solid die machines, rivets may be made entirely free from fins or burrs under the head. This is especially desirable for bolts to be used on surfaces to be painted over, such as on steel passenger cars where a rivet having fins under the head is liable to shift and crack the paint.

ANOTHER WAGE INCREASE FOR MECHANICAL DEPARTMENT EMPLOYEES

Director General McAdoo announced on July 24 by telegraph from the west, his approval of Supplement No. 4 to General Order No. 27, providing the following minimum rate and increases in wages for employees of the mechanical department of railroads under federal control:

1. Machinists, boiler makers, blacksmiths, sheet metal workers, moulders and first class electrical workers, 68 cents an hour.
2. Carmen and second class electrical workers, 58 cents an hour.
3. Helpers; 45 cents an hour.
4. Foremen, paid on an hourly basis, 5 cents per hour more than their respective crafts.
5. Foremen, paid on a monthly basis, an increase of \$40 a month, with a minimum of \$155 and a maximum of \$250.
6. The new rates are retroactive from January 1, 1918.
7. Beginning on August 1, the eight-hour day will be applied, with time and one-half for overtime, Sundays and seven specified holidays.

The new order is lengthy and in detail, and at the time this is written the full text has not yet been issued.

In revising the report of the Railway Wage Commission Mr. McAdoo increased the recommendation for shop employees to a minimum of 55 cents an hour, after which, at

hearings before the Board of Wages and Working Conditions, the shop organizations asked for 75 cents an hour. To meet the increase asked would involve an addition of \$200,000,000 a year to the payrolls on top of the \$300,000,000 increase provided for by General Order No. 27, and other classes of employees have also asked for further advances. To assist him in reaching a conclusion the Director General discussed the matter at a conference with C. R. Gray, director of the division of operation; W. S. Carter, director of the division of labor, and Frank McManamy, assistant director of the division of operation.

PREVENTION OF WASTE VS. RECLAMATION OF SCRAP

BY HENRY J. MILLER

I know a man who is a chicken fancier; not the kind of a fancier who goes in for a farm and a large number of chickens, but rather the kind of a man who thinks he has discovered the solution to perpetual income by keeping a flock of ten chickens, maintaining them on the daily refuse from the table. This man claims the first or initial cost to build a chicken house and purchase the ten chickens is the only cost, and the value of eggs received will soon repay this investment, after which the eggs are a clear gain.

Another man I know of, who has the same number of people in his family, became impressed with the chicken fancier's argument and decided that he, too, would reclaim the waste which was daily thrown away from his table. However, on talking with his wife he was very quickly disillusioned. In the first place, his wife showed him that the actual amount of table refuse she threw away would not sustain even two chickens. Not exactly satisfied with the results of his investigation in his own home, he visited the home of his friend the chicken fancier, where he soon found out the reason why they had so much table refuse for chickens. It was due to poor management in the kitchen. The chicken fancier was under the impression that he was reclaiming waste from his table, while in reality, good management and economical buying would have eliminated the waste. He was not reclaiming—he was buying high grade food products for chicken feed.

The same principle may be applied to the railroads. Wherever one sees a big scrap bin or a big scrap reclaiming plant, the question arises. Is it not possible to eliminate much of this expense by better management?

The writer does not wish to be understood as condemning reclamation altogether. It is possible, however, to lose sight of the real value of reclamation with the result that instead of a saving, reclamation is merely adding to the cost of the scrap pile, in excess of its real return. The reclamation of scrap is to prevent the waste of usable material. This can and should be accomplished right at the local shop or on the division. The best posted authorities as to what is scrap and what can be used over again are the local foremen.

The establishment of one large reclamation plant on a railroad and shipping all scrap to this one plant involves a direct waste. It is a waste of man power, a waste of motive power and an excuse for an even greater waste from the shops. This assertion is made with all due respect to the many large reclaiming plants now in operation. There is use for the reclamation plant, but not for as wide a scope of work as we are often led to believe.

Let us look at the scrap problem of a shop of medium size. The bulk of the scrap is old tires, odds and ends of tubes, pieces of iron from the blacksmith shop, defective pipe, rusted jackets, machine tool chips, broken castings and shop sweepings. What is there in this classification that can be reclaimed and used over again? Where is there any need of a reclamation plant to see that this material is properly

sorted for the scrap market? Like the chicken fancier, it is possible that the source of scrap may be overlooked, and then it is possible to find such valuable parts as bolts, nuts, washers, valves, pipe fittings, pieces of brass, tin ware, etc., in our scrap pile.

Scrap piles have been neglected in the past. They have not been given close supervision and many habits have been formed which to-day are found to be costly. Going back still further, however, there was a time when the scrap bin was literally a scrap bin. It was possible to visit many shops and find nothing but scrap in these bins.

The writer has in mind one shop that handled about 10 heavy repaired locomotives and possibly 150 cars a month. The scrap bin was guarded by one man—a man whom everybody put down as a crank, but who was a 100 per cent scrap bin attendant. The scrap bin was located near the center of the plant, easy of access, and was of sufficient size to allow an ample compartment for each of the many classifications of scrap. The attendant had an eagle eye for anything but scrap. Woe to the man who tried to put anything over on him, for he was a fighter and had a nasty tongue. He reserved one compartment where he put everything regarding which there was any doubt, and during his spare moments would sort over the material, in many cases sending pieces that could be repaired at a small expense back to the shop. From this plant probably not one carload of scrap out of every thirty would not have been passed through any reclamation plant as actually worthless. Why the unnecessary expense of loading, hauling, unloading, sorting and loading again before hauling to a buyer? If this has proved possible at one plant, then why not at others?

At another plant the matter of using second-hand shoes and wedges was taken up with the mechanic who handled that work. He was given the exact cost of the different castings and was shown how much was saved by using a second-hand piece if it was in condition to be used again. This mechanic knew the service of shoes and wedges better than the scrap bin attendant and took pride in saving all the money he could. The result was that what shoes and wedges reached the scrap pile were actually scrap beyond reclaiming. Incidentally, this schooling had a decided effect on the amount of stock used at this shop. If it is possible to educate one mechanic as to the value of using second-hand shoes and wedges, why not educate the men who use other materials, and thus do away with handling so much scrap at the reclamation plants?

The function of the reclamation plant is simply to repair where shop facilities are limited or inefficient to handle material in small quantities. It is evident that the amount of scrap iron at local points would not be sufficient to warrant the installation of reclaiming rolls and it is desirable to select some central point for the installation of a rerolling mill to serve the entire road. Under these conditions, however, each local point should sort such material as can be reclaimed, so that on reaching the reclamation plant it need not be resorted.

At a certain reclamation plant a man was observed reclaiming a large pile of rail spikes, straightening them out cold with a hand hammer. Let us follow one rail spike from the time it started to the scrap pile until it is reclaimed and delivered back to the section gang.

A section man, in pulling the spike out of the tie, bends it. Knowing that there is a reclamation plant on the system he puts the bent spike on the scrap pile. The spike is loaded in a car with other scrap and hauled to the reclaiming plant, where it is unloaded, sorted out and placed before the man with the hammer. He straightens it, after which it is taken into store stock, eventually to be loaded and hauled back to the section foreman. If there is no imperfection in the head or point the foreman uses the spike again. Otherwise he

looks the spike over, notes the imperfection and either struts it back on another journey to the reclaiming plant or throws it in the tall grass, where the railroad loses its value as scrap. If that section foreman were educated as to the needs of his railroad and the value of using material economically, is it not possible that one of his men would have straightened that spike on a rail, thus saving the cost of handling and moving? Was it necessary to handle that spike three or four times and haul it to and from the reclamation plant just to have it straightened?

At another plant the discovery was made that many apparently good air pump cylinder packing rings were going to the scrap pile. Investigation disclosed that the mechanic who overhauled air pumps would not use a questionable second-hand ring in a newly repaired air pump. He claimed that such a pump would run six months without repairs, but if a second-hand packing ring was used the pump would probably require attention in a month or so. He had concluded that it was better to throw away a second-hand packing ring worth 40 or 50 cents than to use this ring and in a month or so spend from two to three dollars in making repairs to the pump in the roundhouse.

A visit to a large reclamation plant causes one to wonder why so much good material is shipped there. May not the answer be that too much dependence is placed on the reclamation plant? Place a scrap bin in the center of every plant, with a man in charge who knows good material, and the reclamation plant will receive much less good material, and scrap handling costs will be reduced. A means of education will be provided right where every workman can see what the wasteful use of material results in.

Put some of the money otherwise spent in building a big reclamation plant into educating and securing the co-operation of your workmen and you will receive a larger dividend in return.

MAINTENANCE OF CROSS-COMPOUND COMPRESSORS

The subject matter of this paper naturally divides into two parts, viz. one covering the period between shoppings of the compressor and the other while it is in the shop for a general overhauling. Considering the former first:

Location and Installation.—Cross compound compressors should always be located on the left side, forward of stay-bolts. While the design of the locomotive will to a certain extent determine the exact location, a location entirely below the running board and as near the rear of the boiler barrel as possible is preferable. A large opening and free-passage strainer should be installed in a vertical position and secured to a substantial bracket. It should be located so as to be free from dirt thrown up by the driving wheels and where it will not be subjected to escaping steam. The two suction openings from the compressor should be piped together with two-in. pipes and a similar size pipe then extended to the strainer.

The oil pipe connection to the steam pipe should be between the main steam valve and governor. With a two-compressor installation difficulty is sometimes experienced in lubricating the steam ends of both compressors, due to unequal distribution of oil. To facilitate this the 1½-in. main steam pipe should enter horizontally into the side opening of a 1¼-in. by 1¼-in. by 1½-in. horizontal tee, located adjacent to and above the compressors. From this tee two 1¼-in. branch pipes of equal length should extend to the compressors.

Lubrication.—When starting the compressor the piston rod swabs should be lubricated with valve oil, the throttle

*Abstract of the report of a committee presented at the Air Brake Association.

opened gradually and the compressor run slowly until all condensation is worked out of the steam cylinders, then the drain cocks should be closed. All drain cocks are to be opened, and left so, when compressor is stopped at terminals. While the compressor is yet working slowly, 10 to 15 drops of oil should be fed to the steam cylinders and 8 to 10 drops to each air cylinder. After obtaining about 40 lb. pressure the throttle can be opened.

The air cylinders should be lubricated regularly, four to six drops, how often depending on the service, but never over six hours apart in heavy freight service, and especially just before starting down a mountain grade. With cab air cylinder lubricators, which are superior to the hand oilers, never attempt to adjust to feed continuously, as the slowest possible regular feed will be excessive.

There has been considerable criticism regarding the use of superheater oil in the compressor air cylinders, the general impression being that it is too heavy, tending to more quickly clog the passageways and packing rings. While it is conceded that better results may be obtained with Perfection valve oil, yet where the special 54 air strainer is employed no trouble is experienced from the use of superheater oil, thus indicating that the gumming with it is mainly due to dirt.

Compressor Laundry.—Dirt entering the air cylinders destroys lubrication and increases the wear of packing rings and cylinder walls. The dirt and worn-off metal form the hard gum so frequently met with; hence, the exclusion of dirt will improve the lubrication and reduce the wear and gumming.

A very effective and economical way to remove this deposit is by means of the compressor laundry, which should be used every three months or longer, depending on the service and protection afforded against dirt. Compressor laundry outfits consist in general of an enclosed tank mounted on wheels, for a lye solution, a steam coil inside the tank and suitable pipe connections to join the tank to the suction and discharge openings of compressor. The solution should consist of about one lb. of concentrated lye to one gal. of water, and should be kept hot by steam circulating through the coil while the compressor is being laundered.

The length of time the compressor should thus operate depends on its dirty condition, but usually from two and one-half to three hours gives the best results. After the compressor has been thoroughly cleansed the tank connections should be removed. Clean water (hot water is preferable) should then be worked through the air cylinders for several minutes, discharging into the pit, to insure all of the solution being removed, after which the compressor should run idle until all the water is worked out of the cylinders. The air cylinders should then be well lubricated, the strainers applied and the discharge pipe connected. If soft packing is used the air ends may need to be repacked. A solution of about 10 gal. will be sufficient to cleanse about five compressors.

Insufficient lubrication, especially in the steam end of the compressor, is one of the most common causes for the compressor running slow. On roads where valve oil seems to be at a premium, either by an oil schedule or otherwise, the air compressor is usually the part that is stinted to make an oil record. At the normal cost, of about 55 cents per gal., for oil it will cost 5 cents per 16-hour trip to properly lubricate both ends of the compressor.

Other causes for the compressor running slow are worn packing rings in the high-pressure air cylinder or clogged passages in the air cylinders. No trouble will be experienced with the latter if the compressor laundry is used as herein recommended. The compressor will pound or make irregular strokes from causes such as main steam valve dry,

packing rings in low-pressure air cylinders badly worn, piston rod packing blowing, clogged air passages, air valves with improper lift or leaking, and too much oil in the steam cylinders in combination with close throttling by the steam valve or governor.

The compressor will give good service when the low-pressure air piston packing rings are worn until 3-32 in. to 5-32 in. open. The latter should be the limit.

A slow upward stroke of the low-pressure air piston may be caused by a restricted air passage between high and low pressure air cylinders, or top steam cylinder gasket leaking to the top side of high-pressure steam piston, or high-pressure air piston packing rings leaking, though if the latter were at fault the low-pressure air piston would move slowly in both directions. If the high-pressure air piston makes a quick downward movement and the low-pressure air piston a quick, upward movement, the cause may be on account of a lower intermediate valve leaking or held off its seat. If the quick movements of the pistons mentioned are in the opposite direction than stated, the cause may be from an upper intermediate valve leaking. If the high-pressure air piston only makes short strokes, and compressor will not maintain more than 45 to 60 lb., it indicates discharge passages badly clogged, or final discharge valve leakage.

When a compressor gradually keeps reducing in efficiency until it does not maintain standard pressures under relatively favorable conditions, the trouble is usually due to worn and leaking high-pressure air piston rings. Under these conditions the low-pressure air piston will be working against more than its normal pressure. Low speed can also result from steam cylinder gasket leakage, and if leaking between ports of high and low pressure cylinders, or between low-pressure cylinder and exhaust, it can be located by a continuous blow at the exhaust, providing the exhaust pipe is disconnected close to compressor and the latter run slowly. If the compressor has been maintaining standard pressures, and in a relatively short time does not, the trouble is undoubtedly due to some foreign substance lodging under an intermediate or discharge valve, thereby causing serious leakage. Such foreign substance can at times be removed by closing compressor throttle and brake valve cut-out cock, draining all pressure from main reservoirs, after which run the compressor fast for a few minutes. After the main reservoir pressure is restored, open brake valve cut-out cock.

The report was signed by C. N. Remfry, chairman; T. F. Lyons and Frank Schaller.

DISCUSSION

The discussion emphasized several of the points brought out in the paper, and indicated that the most difficult problem in the operation of the 8½ in. cross-compound compressors is properly lubricating the air cylinders. The use of signal oil, which is sometimes permitted, has resulted in explosions in the air cylinder, and is not desirable. The difficulty of using present types of hydrostatic lubricators on these pumps is that the minimum feed is too fast for continuous use and requires periodical attention from the engineman. Another handicap under which these pumps work is the inefficient condition in which air strainers of the ordinary type are maintained, the openings being partially clogged and restricted. More attention to maintaining unrestricted strainer openings was advocated.

A CORRECTION

In the article entitled *Metallic Electrode Arc Welds*, by O. S. Eschholz, published last month, an error was made in the second column of page 417 in giving the carbon and manganese content of the electrode. This should be .17 per cent carbon and .5 per cent manganese.

WELDING METHODS AT COLUMBUS SHOPS

Carbon and Metallic Arc Welding Both Used; A Special Building Has Been Erected for Welding Work

THE Southwest System of the Pennsylvania Lines has recently erected at the Columbus, Ohio, shops, a special building which is devoted exclusively to electric welding. Many interesting details were incorporated in the design to fit the structure to the purpose for which it was intended. The building is of brick 101 ft. long and 19 ft. wide and is divided into seven welding rooms, 12 ft. by 16 ft., inside, and a generator room, 14 ft. by 16 ft. The generator room has brick walls, while the welding rooms are separated by corrugated iron partitions. As the light from the arcs is harmful to the eyes unless shaded by colored glasses, pro-

vision has been made for protecting anyone from the rays who may come in the vicinity of the building. The windows in the welding rooms are 8 ft. from the ground and the opening near the welding table for the admission of air is covered by an iron door hinged at the top. The entrances to the welding rooms have sliding doors, one solid and the other with latticed panels, to provide ventilation. In order to insure that all fumes from the arcs will be carried away quickly an exhaust fan has been installed in the generator room and connected to a central duct, from which smaller ducts in each room lead to adjustable exhaust hoods directly over the welding table. There is also an 18-in. roof ventilator in each room. The entire building is heated by warm air pipes brought in at the floor level.



Interior Arrangement of Welding Room.

vision has been made for protecting anyone from the rays who may come in the vicinity of the building. The windows in the welding rooms are 8 ft. from the ground and the opening near the welding table for the admission of air is covered by an iron door hinged at the top. The entrances to the welding rooms have sliding doors, one solid and the other with latticed panels, to provide ventilation. In order to insure that all fumes from the arcs will be carried away quickly an exhaust fan has been installed in the generator room and connected to a central duct, from which smaller ducts in each room lead to adjustable exhaust hoods directly over the welding table. There is also an 18-in. roof ventilator in each room. The entire building is heated by warm air pipes brought in at the floor level.

The arrangement of the apparatus in the welding rooms is clearly shown in the illustration below. A welding table is provided to bring the work to the height most convenient for the operator. Beside the table is a stand on which the electrode holders are placed. A rack for the welding rods and a metal box for holding tools are also provided. To facilitate the handling of heavy parts each room has a chain hoist of 1-ton capacity swung from a jib crane.

The generators used for electric welding were rewound from two 60-hp., 240-volt motors. By running connections to each third commutator bar they were changed to give approximately 80 volts. The fields are compound wound

with a differential series coil. The generators are driven by 100-hp. induction motors. Each machine delivers a maximum of 1,000 amperes, which is sufficient to supply one metallic arc and two carbon arcs.

In the generator room is a small switch board which carries the volt meters and ammeters, the field rheostat and the circuit breakers, which are connected with the positive side of the circuit. The welding circuits are carried from the circuit breakers by separate leads to each of the welding rooms and are brought back to the center post of a series of single pole double throw switches, through which any of the circuits may be connected to the negative terminals of either generator. The circuits are designed to carry a current of 600 amperes.

One circuit is carried to the erecting shop, where it is connected to the welding panel shown in the illustration below. This is arranged for the use of two operators on metal electrode work. If it is desired to use a carbon arc the

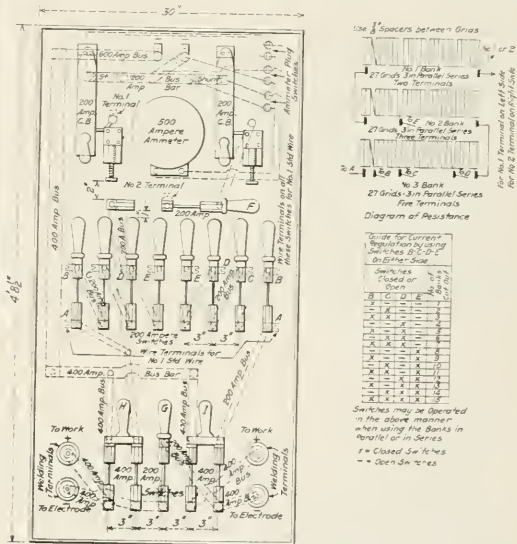

Two-Man Welding Panel.

entire current can be diverted to either set of welding terminals by closing the switch G.

The welding practice at Columbus shops is quite unusual in that much of the work is done with the carbon arc. The carbon arc process was the first method of welding metals with the electric arc that was developed, and has been in use since 1881. The welding heat is generated between the work and a carbon electrode, the arc being played around on the work to get the proper heat, while the metal to be added is fed into the arc. In many ways the manipulation of the arc is similar to the manipulation of the oxyacetylene flame.

Metal electrode welding has been adopted much more generally than the older carbon arc process, which is in use by very few railroads. The reasons generally ascribed for the

use of the metal electrode process are that the quality of the metal added is better than is secured when using the carbon arc, that the heat can be controlled more readily, and that it can be used for overhead welding and other work where it is not possible to form a pool of the molten metal.

The advantages of the carbon arc process which led to its adoption in the Columbus shops are the greater speed in building up work and the lower cost on heavy work. When using the carbon electrode a longer arc is maintained than when using the metallic arc and for that reason it has been found the slight variations in the length of the arc have less effect on the quality of the metal. The character of the work secured depends largely on the skill of the operator. It has been found that an experienced operator can produce a very good grade of metal in the welds. The intense heat of the arc makes the molten metal so fluid that it is easy to float off the scale.

About three-fourths of the work done at Columbus is welded with the carbon arc. This includes practically all building up operations and repairing the commoner classes of broken parts. All crosshead guides are maintained to a standard size, from $\frac{1}{4}$ to $\frac{3}{4}$ in. of metal being added to restore the original dimensions. Chafing castings are built up with the carbon arc, holes in spring rigging and brake rigging that are worn out of round or spots that are chafed are built up. Broken driving and trailer boxes, and in fact practically all kinds of steel castings, are welded with the carbon electrode. Copper can also be welded by this process with entire success. No difficulty is encountered in machining the metal which is added.

In carbon welding, electrodes $\frac{1}{2}$ in. and $\frac{3}{4}$ in. in diameter are used. The rods, which are fed into the arc, are $\frac{3}{8}$ in., $\frac{1}{2}$ in. and $\frac{5}{8}$ in. in diameter. The voltage across the arc varies from 50 to 55 volts and the current is usually between 400 and 450 amperes.

In working with the carbon arc the face and hands must be protected, as the rays from the arc will burn the skin. A very convenient and practical form of face shield has been developed at the Columbus shops. It is made largely of fiber which is light and a non-conductor of heat and elec-

tricity. The frame which holds the colored glass is hinged and is held in either the open or closed position by a spring. A fireproof bib protects the chest of the operator from the heat of the arc.

There are certain classes of work for which the carbon arc is not well adapted and for such operations the metallic arc is used. These include the welding of firebox cracks and seams, mud rings and tubes, welding broken locomotive frames and broken spokes in wheel centers. Link blocks, valve stems, superheater units and crossheads are built up with the metallic arc. On these classes of work a voltage of approximately 18 to 20 volts across the arc is used, with a current from 100 to 175 amperes. The electrodes used on building up operations are $\frac{3}{16}$ -in. or $\frac{1}{4}$ -in. Swedish iron. On firebox work $\frac{1}{8}$ -in. rods are used, on tubes $\frac{1}{8}$ -in.

A CROSSHEAD FACING TOOL

The inner surfaces on the sides of cross-heads are difficult to machine in a slotter. Nevertheless on account of the difficulty of reaching these points with an ordinary lathe tool the surfaces are usually slotted out. The illustration below

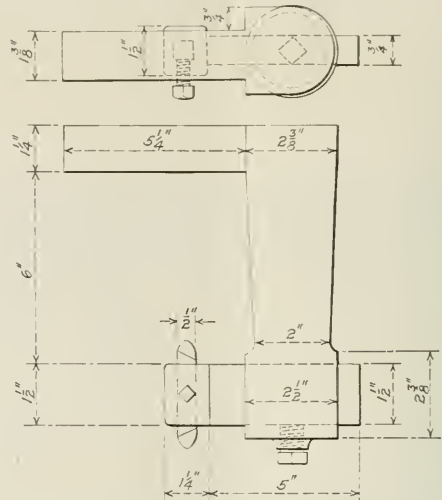

Tool Which Cuts the Time for Machining Crossheads

shows a tool used in the Bloomington shops of the Chicago & Alton which makes it possible to finish both of the inside surfaces on crossheads at one setting.

The body of the tool is designed to pass through the cross-

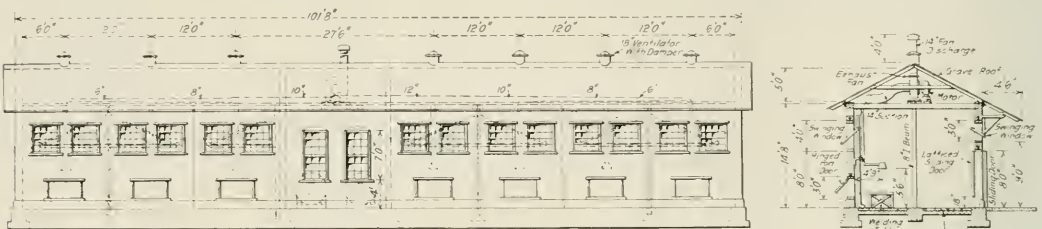

Side Elevation and Section with Partitions Removed—Columbus Welding Shop

tricity. The frame which holds the colored glass is hinged and is held in either the open or closed position by a spring. A fireproof bib protects the chest of the operator from the heat of the arc.

There are certain classes of work for which the carbon arc is not well adapted and for such operations the metallic arc is used. These include the welding of firebox cracks and seams, mud rings and tubes, welding broken locomotive frames and broken spokes in wheel centers. Link blocks, valve stems, superheater units and crossheads are built up with the metallic arc. On these classes of work a voltage of approximately 18 to 20 volts across the arc is used, with a current from 100 to 175 amperes. The electrodes used on building up operations are $\frac{3}{16}$ -in. or $\frac{1}{4}$ -in. Swedish iron. On firebox work $\frac{1}{8}$ -in. rods are used, on tubes $\frac{1}{8}$ -in.

head pin hole, with considerable clearance at the sides. On one end the tool has an arm which fits in the tool post of the lathe. The other end carries a removable arm in which there is a double end cutter held in place by a set screw. The body of the tool is passed through the crosshead pin hole, and the removable arm is then placed in position. By using the cross feed the inner surfaces can be finished in perfect alignment with the outer surfaces. If the clearance of the tool in the crosshead pin hole is not great enough to permit the entire surface to be finished in one cut, the tool can be brought back and the removable arm set out to finish the cut. With this tool the time required to machine crossheads can be reduced considerably. Where nuts are used on the ends of piston rods, a tool of this sort will be found useful for finishing the bearing surface for the nut on the crosshead.



NEW DEVICES



MOTOR HEAD SPEED LATHE

A new speed lathe with alternating current motor headstock has recently been placed on the market by the Oliver Machinery Company, Grand Rapids, Mich. The lathe is designed for three-phase, alternating current operation and is called the Oliver No. 51.

As shown in the illustration, the lathe is provided with a hand feed carriage and compound swivel rests, but may be furnished with a plain bed in four or five-foot lengths if desired. In this case it will turn 24 or 36 in. between centers, respectively. The swing of the lathe is 12 in. and it is well adapted to work in pattern shops.

The motor headstock and ball bearings are totally enclosed, which makes them dust and dirtproof. The rear end of the motor is fitted with a combined handwheel and face

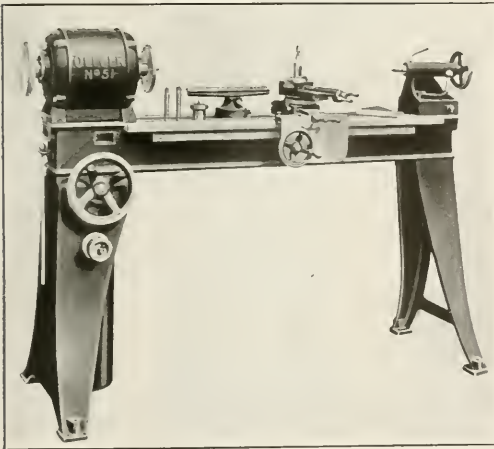

"Oliver" No. 51 Motor Head Speed Lathe

plate, which is a new invention, covering which a patent has been applied for. The outer end is rounded off like the ordinary handwheel and the inside face is curved in so as to give the advantage of the handwheel shape. The outer surface forms an accurate face plate for rear end turning. The motor controller is also enclosed in a dust-proof case and is similar in type to a street car controller, but much smaller. It is operated from the handwheel shown in the front, which is marked in the various positions, as follows: Off, 570 r.p.m., 1,140 r.p.m., 1,725 r.p.m. and 3,450 r.p.m. The mechanism is such that the handwheel cannot be turned in the wrong direction. All parts of the lathe are interchangeable.

THREE-WHEEL TRACTOR

The Elwell-Parker Electric Company, Cleveland, Ohio, has developed the tractor shown in Fig. 1 for medium service and to occupy a position about halfway between the common electric truck and the heavy duty tractor. It is giving excellent service in small package freight houses, and Fig. 2 illustrates its use in unloading a freight car of flour.

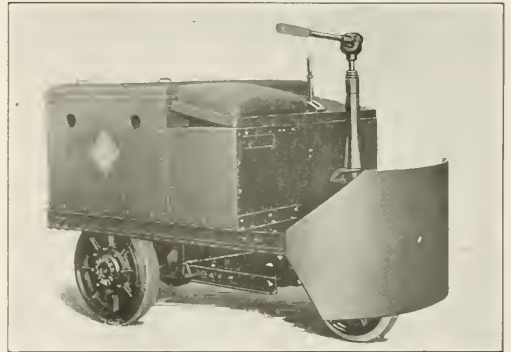

Fig. 1—Elwell-Parker Three Wheel Tractor

There are one hundred 25-lb. sacks of flour on each of the trailers shown, making a total of 10,000 lb. of flour hauled by one motor. One of the distinctive features of the Elwell-Parker tractor is the single front wheel, which makes pos-



Fig. 2—Removing 10,000 Lb. of Flour at One Trip

sible greater ease in turning, and on this account it could probably be used to good advantage in railway repair shops.

The tractor is steered by a handwheel or a hinged right and left hand lever. When the wheel steer is used, the con-

trol lever is located on the left of the column. When the lever steer is used, the control lever is located at the side of the operator's seat, as shown. The steering wheel is carried on roller bearings in a heavy steel box spring supporter, turning on large ball bearings in the steering column base. The seat operates as a circuit breaker, which closes when the operator's weight presses the spring, but only when the controller is in "off" position. The tractor can never be started from the floor.

The tractor has solid wheels and solid rubber tires. The normal drawbar pull is 300 lbs., the speed with no load is 0.25 ft. per minute. The length of the tractor is 70 in. and its width is 41 in. The outside turning radius is less than the length of the tractor. A single reduction worm drive is used, the worm being steel and the worm gear phosphor bronze. The motor is direct connected to the worm on a full floating axle. The tractor has a brake pedal with a heel latch.

The battery may be removed through the top or side of the compartment as a unit, and is not boxed in single cells, as in many tractors. This facilitates the quick exchange of batteries if required. The battery cradle is suspended on springs. The tractor frame is carried on separate sets of springs over the rear axle. There are three speeds in either direction. The tractor is equipped with an Elwell-Parker heavy-duty motor and an Edison or lead battery.

NEW IDEA VISE

The Barnett Foundry & Machine Company, Irvington, N. J., has just brought out a machinist's bench vise under the name of "Winans' New Idea Vise," that embodies a number of novel features. Reference to the illustration indicates its general characteristics. It will be seen that the well known screw and lever has been replaced by a pawl and rack. This is actuated by a handle on an eccentric shaft, which will exert a pressure much greater than possible with a screw.

The adjustments from zero to maximum are made in-

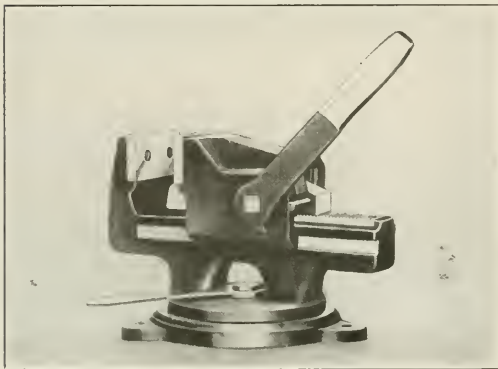

Winans' New Idea Vise

stantly with one sliding movement. The pawl eccentric and sliding jaw form a toggle joint, bringing the greatest pressure to bear on the top part of the jaw, causing the work to be clamped tightest at the working part. The moving member of the vise slides away from the operator and there is no handle between the operator and the vise. The gripping plates are hardened and ground, and the rack and pawl are made of hardened steel.

A feature of especial importance is that the whole vise may be removed from its swivel base and taken to a surface

plate, drill press or milling machine for continuous operations, since the base of the vise is accurately machined at right angles to the jaws.

The Winans' vise is made in standard sizes of jaws from 3 in. to 8½ in. and openings of 3½ in. to 12 in. The whole design is such that it will stand up under trying conditions and heavy work.

DRAFT RECORDING DEVICE

The economical operation of steam plants is made possible only by a thorough knowledge of operating conditions, and automatic recording devices of various sorts are a great aid in obtaining this knowledge. For example, one of the factors that affects boiler efficiency is the amount and uniformity of the draft, and an accurate knowledge of just how the draft varies from time to time during the day may explain the size of last month's coal bill.

It is also important that the right amount of air be furnished under the grates, and for the purpose of recording

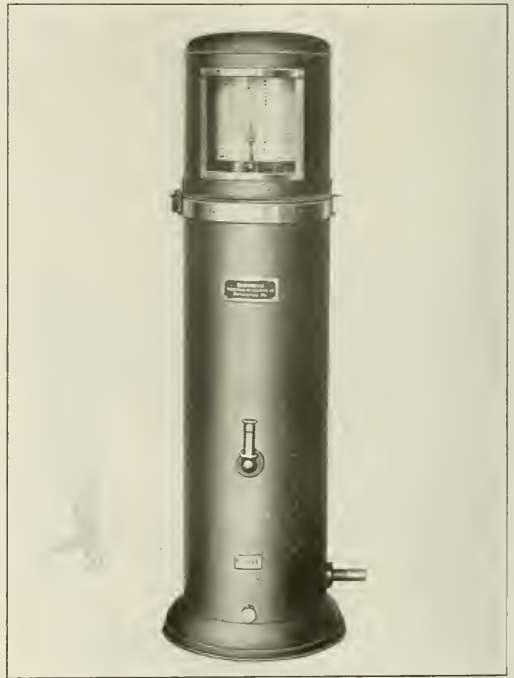

Hydro Pressure Recorder

such gas pressures, the Bacharach Industrial Instrument Company, Pittsburgh, Pa., has manufactured various types of "Hydro" pressure recorders, one of which is illustrated.

The instrument is simple in construction, its action depending on but one moving element, namely, a float in water. The float is in the form of an inverted bell communicating with the stack or gas main and the outside, the top of the bell being exposed to atmospheric pressure. The difference in pressure then between the stack and the air is measured by the vertical position of the bell and transmitted to a recording device by a rigidly connected pen. The recording chart is carefully calibrated and attached to a drum which revolves once in 24 hours by a clock arrangement. The re-

sult is a continuous and permanent record of draft pressure and variation.

An important advantage of the "Hydro" pressure recorder lies in the fact that it has no lever, pinion, stuffing box, etc., to wear out and cause inaccurate readings. It is durable, being made of non-corrosive metals and does not require careful leveling to give accurate results.

"Hydro" pressure indicators are built by the same company and differ from the recorders only in the substitution of a simple indicating mechanism for the recording device.

GLASS LUBRICATING CUP

A new lubricating cup for air compressor air cylinders has been patented by E. F. Glass, 1212 Third avenue, Altoona, Pa. As shown in the illustration, the body of this cup is a malleable iron casting threaded on a brass stud, the outer end of which has a $\frac{3}{8}$ in. pipe thread to fit the standard air cylinder oil cup hole. A brass stem with a shoulder at the top, and a $\frac{1}{8}$ -in. hole running through it is screwed into the top of the stud. There are four $\frac{1}{16}$ -in. holes drilled through the top of the stem under the collar, and the wicking shown is made of .03-in. woven copper wire. The filling hole in the top of the cup is covered by a cap.

In operation, the cup is filled with oil and the cap screwed tightly on. Due to capillary attraction, oil feeds up the wire wicking to the four holes in the top of the stem, and on the

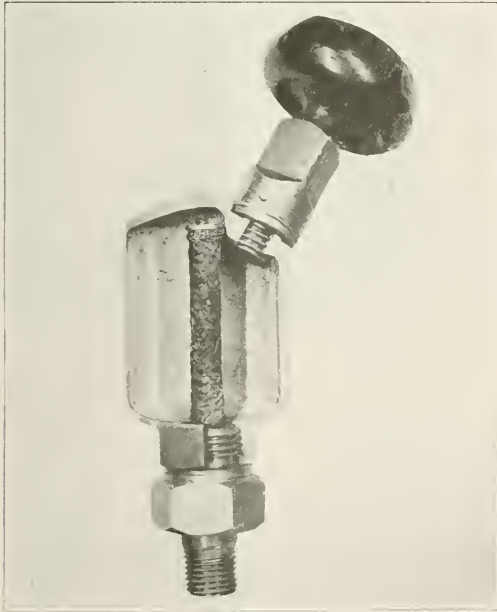

Glass Patent Lubricating Cup

expansion stroke of the compressor this oil is drawn through the hole, and down the stem into the cylinder. The amount of oil may be varied by changing the number of strands in the wicking.

The cylinder lubrication obtained by this method is complete, and results in increased compressor efficiency, and a material reduction in the wear of packing rings, cylinder and piston rod. Further advantages of the Glass lubricating cup are its simplicity and the lack of all regulating screws, valves

and small ports to be obstructed by dirt. One filling of the cup will last 18 hours, with the compressor in continuous operation, and as the cup works automatically, no attention is required in the meantime. The cup can be used on any design of air compressor or internal combustion engine. It has given satisfactory results in actual test on one of the large eastern railroads.

PRESSURE GOVERNOR FOR GAS AND LIQUID SYSTEMS

In many power installations where air, other gases or liquids must be maintained under pressure, the demand has arisen for an automatic method of control.

As a result the General Electric Company has developed a new pressure governor to control standard self-starters for motor-operated pumps and compressors. The governor maintains a pressure between predetermined limits on any gas or liquid systems that will not corrode the Bourdon tube.

This governor is called the CR 2922 and can be used on

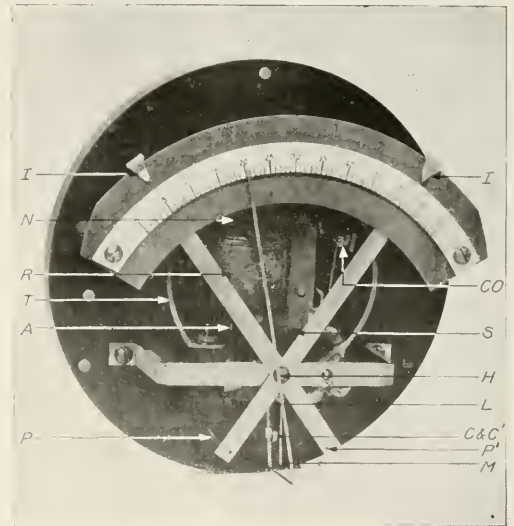

Fig. 1—Internal Mechanism for a Pressure Governor

any standard A.C. or D.C. circuit. It is rated for pressures of 80, 100, 160, 300, or 500 lb. and operates within settings of from 3 to 12 lb. between high and low pressures. Governors for higher pressures can be supplied if desired.

The governor consists of a Bourdon tube, an indicating needle, a graduated pressure scale, adjustable high and low pressure stops to determine the desired pressure range and a relay which actuates the contacts in the control circuit of the self-starter, all enclosed within a dustproof case, easily opened for inspection.

Action of the governor is dependent on the Bourdon tube, which should be connected to an independent discharge pipe from the pressure tank. The free end of the tube *T*, Fig. 1, is mechanically connected to the indicator needle *N*, moving it over the scale as changes of pressure affect the tube.

After the settings for the pressure range have been made, the governor will automatically maintain pressure within those limits. Assuming that the pressure is at the low value, as indicated by the left hand indicator *I*, the contact *C* on the needle *N*, completes the circuit through the contact *C'* on

the movable arm *M*, which at the low pressure point rests against the stop *P*. When this contact is made, the circuit is completed through the relay coil *R*, causing the armature *A* to close. Attached to this is the contact *CO* which upon closing completes the control circuit to the self-starter, causing the motor to start.

The armature is also attached to the spring *S* which holds the contact *C* firmly against *C* until contact is broken at *P*. As the pressure increases, the needle pointer moves to the right, but its lower part, to which the contact *C* is attached, moves to the left and is followed by the movable arm *M*. When the high pressure point is reached, the movable arm is prevented from traveling further by stop *P* and the needle continues its course, breaking the circuit by separating contacts *C* and *C*. The instant the circuit is broken, the relay *R* is de-energized, its armature falls, releasing the tension of the

motor belt. Pump piping and attachments for lubrication are included in the equipment.

The motor is mounted on a bracket on the left hand side of the machine and connected by belt directly to the main driving pulley on the back of the upright. The drive is then transmitted through bevel gears and spur gears to the spindles at the top of the saddle. The saddle is counter-weighted and has vertical feed and hand adjustment. Two changes of feed are available vertically: .04 in. and .007 in. per revolution of the spindle.

The driving pulley is 26 in. in diameter and has a 5 $\frac{1}{2}$ -in. face. The table is equipped with an adjustable back

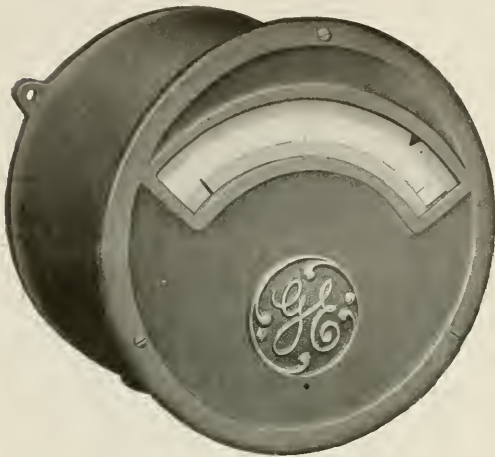

Fig. 2—Pressure Governor Complete

spring *S*, and because the movable arm *M* is counterweighted, it returns to the stop post *P*.

When the pressure is decreased to the minimum value, the contact *C* again completes the relay coil circuit by engaging contact *C* and the cycle of operation is repeated.

The case is tapped and drilled at the bottom for the pressure pipe and electrical conduit connections.

NEWTON RAIL DRILLING MACHINE

A new design of multiple spindle rail drilling machine has been brought out by the Newton Machine Tool Works, Inc., Twenty-third and Vine streets, Philadelphia, Pa. This machine is intended to be used in the rapid and simultaneous drilling of the three or four holes required in the ends of girder and other rails.

Referring to the illustration, the three spindles shown operate separately and are readily removed from the cross rail when desired. The spindle speed for the heavy drilling of main holes is 125 r.p.m. The work table is fitted with a slot in the top surface and an adjustable blocking arrangement to hold the rails in position while being drilled. The two outside spindles are adjustable separately and with regard to the table by means of hand operated screws so that drilled holes may be located wherever desired. All the important driving bearings are bronze bushed. All spindles, spindle gears and rack pinions are made of nickel steel. All gears are fully covered and a guard is placed around the

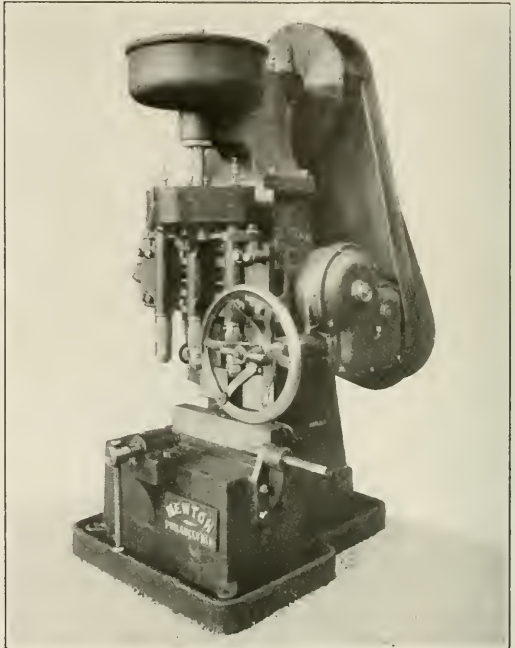

Newton Three Spindle Rail Drilling Machine.

plate, a clamping screw and a reversing end slot. All three spindles are mounted on the one saddle and, therefore, feed in unison, and this particular design is equipped with a special holding chuck for driving drills of special rail design. The base of the machine is surrounded by an oil pan and the lubrication tank is in the base of the machine from which the lubricant is returned by pump piping and attachment to the point of cutting. The following are the general dimensions of the machine:

Diameter of each spindle.....	1 7/8 in.
Minimum distance between spindle centers.....	3 1/2 in.
Maximum distance between spindle centers.....	9 in.
Maximum distance top of table to end of spindles.....	19 1/2 in.
Size of work table.....	16 by 30 in.

CONDITION OF RUSSIAN RAILWAYS.—At a sitting of the Executive of Labor in Moscow, Commissary Shliapnikoff reported on the condition of the railways and the factories of Petrograd. The works and factories, he said, are now in such a state that it will require over three years to bring them to order. The report on the railways shows a state of things beyond all exaggeration. Full and complete disorganization exists among the employees at the stations and at the works. Production has greatly fallen off.—*Railway Gazette, London.*

INSERTED CUTTER TOOLS

The turning, facing and planing tool illustrated is an example of the line of positive lock inserted cutter tools manufactured by the Lovejoy Tool Company, Inc., Springfield, Vt. This company has not attempted to develop a universal holder having adjustment to cover all positions that might be required for tool making and which, therefore, embodies weaknesses unavoidable in a tool of that nature, but the intention has been to design a line of production tools closely approaching the solid forged tool in respect to rigidity, unnecessary overhang and objectionable projections. In this way, and by the satisfactory manufacture of inserted cutter tools, the advantages of a solid forged tool are combined with the economy of the inserted cutter type. There is no

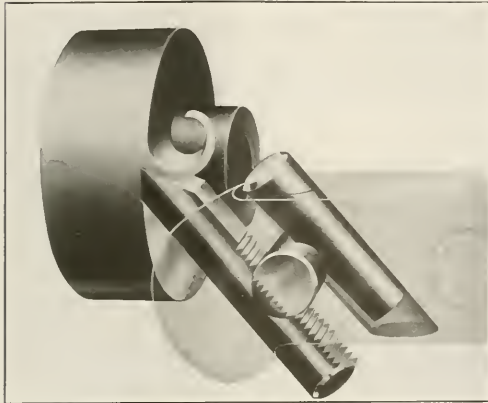

Lovejoy Positive Lock, Inserted Cutter, Turning Tool

waste of expensive high speed steel, which in the solid tool performs no other function than to support the cutting edge. The advantages over tools with welded tips are the smaller chance of breaking and the adjustment of the cutting edge as the tool wears and is ground away.

The Lovejoy tools have a positive lock. In the tool illustrated the tool thrust is taken on the locking key, which in turn takes its seat on the solid metal of the holder. The tapered locking wedge only serves to bind the cutter in position, making it virtually a part of the holder which cannot slip or loosen even under heavy intermittent cuts. The cutter is capable of height adjustment as it becomes worn, thus giving each cutter a life equal to three or four solid or welded tools of the same shank size. New cutters may be obtained at comparatively low cost, there being an almost unlimited life to the holder, which is heat treated and capable of withstanding the heavy strains incident to present day feeds and speeds.

The cutters are high speed steel and are heat treated according to standard practice. They are interchangeable in the respective holders, being made to accurate gauges. The position of the cutter relative to the work is always important and the Lovejoy tools are designed to have the end thrust come as nearly as possible against the cutting strains.

While the nature of boring work does not permit of the relatively ideal conditions for cutter positions afforded in turning and facing, the cutter is so supported in the holder as to receive largely an end thrust and a natural top rake. The grinding is done entirely on the end, and the cutter is locked in its holder with total absence of protruding set screw heads, thereby giving unobstructed chip room in holes only slightly larger than the holder itself. This permits the use of a larger tool than is usually possible in the inserted

cutter type and again approaches the solid forged tool in rigidity.

The Lovejoy inserted cutter tools include right and left turning, facing and planing tools, boring bars, back facing bars and shaper and planer tools. Patented end milling cutters are made to order only.

JIFFY ADJUSTABLE CUTTER

In cutting large circular holes it is still common practice to drill out part of the material around the circumference and chip out the remainder. This method is laborious and the results produced are poor. Realizing the field for a tool which would expeditiously do such work, the firm of Koch & Sandidge, Chicago, has placed on the market the Jiffy adjustable cutter. This tool is adapted for cutting holes from 1 1/4 in. to 6 in. in diameter. With standard knives it will cut through 3/16-in. steel. Special knives can be supplied for cutting through 1/2-in. steel and also for cutting other materials such as slate, marble and fibre up to a thickness of 1 in.

The Jiffy cutter, as shown in the illustration, consists of a swing chuck of cast steel with two adjustable knives, mounted on a central stud and fed by a spring and hand nut. The knives are rotated by a special ratchet wrench applied to the chuck. In using the device a 3/8-in. pilot hole is drilled first and if the material is thin a flange nut is put on the opposite side of the sheet so that the stud may be placed through the pilot hole and screwed onto the flange

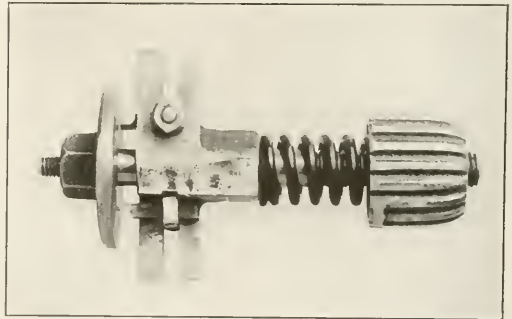

Hand-Operated Cutter Adapted to a Wide Range of Work

nut. In the case of heavy material, the pilot hole can be tapped with the standard thread and the stud set into it, thus eliminating the use of the flange nut where it might be difficult to get back of the material to place the nut in position.

Outside of the many ordinary applications such as cutting holes in distribution cabinets, conduit cut-out boxes, boilers, tanks, etc., there are many special applications, as for instance, cutting holes in heavy structural steel members and in awkward shaped castings which cannot readily be drilled by machine. Special washers which are generally costly to make and difficult to get can be quickly cut out with little effort by setting one of the knives at the inner diameter of the washer and the other at the outer diameter.

CUTTING POINTS FOR GRINDING WHEELS.—The number of cutting points on a grinding wheel is a matter of considerable controversy among theorists. But the best English authority gives for a wheel of 60 grain at 6,000 ft. per minute and one inch wide face a total of about eighty million cutting points per minute.—*The Engineer, London.*

Railway Mechanical Engineer

(Formerly the RAILWAY AGE GAZETTE, MECHANICAL EDITION
with which the AMERICAN ENGINEER was incorporated)

PUBLISHED ON THE FIRST THURSDAY OF EVERY MONTH BY THE
SIMMONS-BOARDMAN PUBLISHING COMPANY

EDWARD A. SIMMONS, *President* M. H. WIUM, *Secretary*
HENRY LEE, *Vice-President and Treasurer* L. B. SHERMAN, *Vice-President*
WOOLWORTH BUILDING, NEW YORK, N. Y.
F. H. THOMPSON, *Business Manager*, CHICAGO.

Chicago: Transportation Bldg. Cleveland: Citizens' Bldg.
Washington: Home Life Bldg.
London: Queen Anne's Chambers, Westminster.

Roy V. Wright, *Editor*
R. E. TRAYER, *Managing Editor*

C. B. PECK, *Associate Editor* E. L. WOODWARD, *Associate Editor*
A. F. STUEBING, *Associate Editor* C. W. FOSS, *Associate Editor*

A fire at Napoleon, Ohio, on July 4, destroyed the round-house of the Detroit, Toledo & Ironton, together with four freight cars, and damaged ten locomotives; loss \$50,000.

The southern regional director has issued a circular letter asking the railroads to submit promptly their recommendations as to the new locomotives each line will require for the year 1919.

President Wilson, by executive order, has suspended the provisions of the eight-hour law as applying to mechanics and laborers on contracts in connection with the construction and maintenance of the Alaskan Railroad.

The machine shop of the Texas & Pacific at Marshall, Tex., was destroyed by fire on June 9; estimated loss, including machines, patterns and valuation records, \$300,000. The boiler shop and the erecting shop were slightly damaged.

V. R. Hawthorne, acting secretary of the Master Car Builders' Association and the American Railway Master Mechanics' Association, has transferred his office from 906 Karpen building to 746 Transportation building, Chicago.

Fifty retired employees of the Pennsylvania Railroad at Sunbury, Pa., were notified recently that places were open for them if they wished to return to work, and provided they should pass necessary physical tests. Many of these men are mechanics. They were told that in going to work now they would not disturb their relations to the company as pensioners.

Employees of the Pennsylvania Railroad in military or naval service, including those from lines both east and west of Pittsburgh, now number 16,407. This is shown by reports just completed for the purpose of revising the figures on the service flag which hangs in Broad street station, Philadelphia. When the flag was first hung, March 20, 1918, the single blue star in the center contained the number 11,769, showing an increase of 4,638.

In conjunction with its preparation for taking over the recruiting and supplying of common labor for war industries on August 1, the United States Employment Service is taking comprehensive measures to relieve the shortage of skilled workers, particularly machinists, which is handicapping the output of war materials and is little less serious than the common labor shortage. While the ban against private labor recruiting for war work for the present applies only to unskilled labor, it will eventually include skilled workers, such centralized skilled labor mobilization to be

Entered at the Post Office at New York, N. Y., as mail matter of the second class.

Subscriptions payable in advance and postage free: United States, Canada and Mexico, \$2.00 a year; Foreign Countries, \$3.00 a year; Single Copy, 20 cents.

WE GUARANTEE, that of this issue 7,100 copies were printed; that of these 7,100 copies 3,985 were mailed to regular paid subscribers, 212 were provided for counter and news companies' sales, 199 were mailed to advertisers, 177 were mailed to exchanges and correspondents, and 527 were provided for new subscriptions, samples, copies lost in the mail and office use; that the total copies printed this year to date were 63,400, an average of 7,925 copies a month.

THE RAILWAY MECHANICAL ENGINEER is a member of the Associated Business Papers (A. B. P.) and of the Audit Bureau of Circulations (A. B. C.)

carried out through the common labor recruiting and placing machinery now being completed in each state by the federal employment service.

The women employed on the Pennsylvania Railroad now number 10,248, or 1,481 more than on June 1. Women are working in 69 classified occupations on that road. There are 6 working on car repairs, 74 at cleaning locomotives, 4 as locomotive dispatchers, 29 as draftswomen, 1 is a coal inspector, 595 as laborers, 234 are messengers and assistant messengers, 9 are drawbridge attendants, 38 work as freight truckers, 1 is a trackwoman and 92 are employed as crossing watchwomen. Many other kinds of work are shown in the list, including 152 signalwomen and assistants.

As a result of a number of conferences of the United States fuel administrators and their committees, plans have been made for extending the program of coal saving in power plants to all states east of the Mississippi, and including Louisiana, Missouri and Minnesota. An administrative engineer will be appointed for each of the states in the area mentioned, who will work under the supervision of the present Federal administrator. No separate or new organization is contemplated, but sufficient addition to the working force in each state will be made to insure efficient execution of the new function. Questionnaires are being sent to owners of every power plant in each district and personal inspection will be made of all plants. They will be classified and rated, based upon the thoroughness with which owners conform to recommendations. Responsibility of rating plants will fall upon the administrative engineer in each state and the state fuel administrator in his judgment may entirely or partially shut off the supply of coal to any needlessly wasteful plant in his territory.

Fuel Conservation Section Organization Completed

The Fuel Conservation Section of the Division of Operation has now completed its organization to conform with the new regions. Its members are as follows: Eugene McAuliffe, manager; Major E. C. Schmidt, assistant to manager; Robert Collett, assistant manager, Eastern Region; Howard C. Woodbridge, supervisor, Allegheny Region; Harry Clewer, supervisor, Pocahontas Region; Bernard J. Feeny, supervisor, Southern Region; Frank P. Roesch, supervisor, North-western Region; Leslie R. Pyle, supervisor, Central Western

Region, and J. W. Hardy, supervisor, Southwestern Region. The section's head office is 629 Southern Railway building, Washington, and there is also an office in the Union Electric building, St. Louis, Mo.

New Western Purchasing Committees

The Western Regional Purchasing Committee has been dissolved and replaced by three separate committees, one for each of the three regions which formerly constituted the Western Region. The committees appointed are as follows:

Southwestern Region.—The headquarters of this committee are in St. Louis, Mo. It is composed of Charles A. Howe, general purchasing agent of the Missouri Pacific, St. Louis, Mo., chairman, and J. L. Cowan, purchasing agent, San Antonio & Aransas Pass, San Antonio, Tex.

Northwestern Region.—Headquarters are in Chicago and the chairman is L. S. Carroll, general purchasing agent of the Chicago & North Western, Chicago. F. A. Bushnell, purchasing agent of the Great Northern at St. Paul, Minn., is the other member of this committee.

Central Western Region.—L. N. Hopkins, purchasing agent of the Chicago, Burlington & Quincy at Chicago, is chairman of the Central Western Region, headquarters being in Chicago, and M. J. Collins, general purchasing agent of the Atchison, Topeka & Santa Fe at Chicago, is the other member.

All instructions and circulars heretofore issued by the Western Regional Purchasing Committee will remain in effect until further notice.

Federal Supervisors of Equipment

A number of the district inspectors of the Interstate Commerce Commission's Bureau of Locomotive Inspection have been transferred to the Locomotive Section of the Railroad Administration under the direction of Frank McManamy, whose title has recently been changed from manager, Locomotive Section, to assistant director, mechanical department of the Division of Operation, and have been appointed supervisors of equipment. These supervisors of equipment travel from road to road on orders from the Washington office, checking up the work of railroad shops engaged on the repair of locomotives and cars to see whether the shops are adequately equipped for their work, whether the work is being properly performed and whether the proper output is being obtained. A considerable portion of their time has been taken up recently in efforts to prevent strikes among the shop employees.

The list of supervisors of equipment who have been engaged in this work since some time in March is as follows: John G. Adair, Joe Beeme, Harvey Boltwood, George N. DeGuire, George E. Dougherty, John M. Hall, John P. Kane, William Martin, John McManamy, Charles J. Scudder, John Wintersteen, and R. H. Collins, assistant supervisor of equipment.

Committee on Standards for Locomotives and Cars

A permanent committee on standards for locomotives and cars has been created by the Railroad Administration to succeed the car and locomotive standardization committee, which has had charge of the development of the designs for the standard cars and locomotives recently ordered by the Railroad Administration. The new committee will have the function of following up the standardization plans for the purpose of recommending any changes which may be found necessary in the standards already adopted or of developing additional standards. Forms have been prepared on which a record will be kept of the performance of the standard cars and locomotives for the purpose of recording any failures or any defects which may be developed in operation so that the

records may be available when any additional orders for equipment are to be placed. The members of the committee, are as follows: Frank McManamy, assistant director, mechanical department of the division of operation, chairman; H. T. Bentley, Chicago & North Western; H. Bartlett, Boston & Maine; J. T. Carroll, Baltimore & Ohio; C. E. Fuller, Union Pacific; F. F. Gaines, Central of Georgia; A. W. Gibbs, Pennsylvania Railroad, eastern lines; H. L. Ingersoll, New York Central; J. E. O'Brien, Missouri Pacific; John Purcell, Atchison, Topeka & Santa Fe; F. P. Pfahler, mechanical engineer, locomotive section, Railroad Administration; J. W. Small, Seaboard Air Line; J. J. Tatum, Railroad Administration; and W. H. Wilson, Northern Pacific. E. A. Woodworth, who was assistant to Mr. Bentley as mechanical assistant in the division of operation, has been appointed secretary of the committee, which held a meeting at Washington on July 16, and thereafter will hold monthly meetings on the third Tuesday of each month.

Changes in M. C. B. Rules

The Master Car Builders' Association has issued Circular No. 1, dated June 22, stating as follows:

In view of the present abnormal conditions as to the material situation in this country and to encourage and facilitate repairs to cars, the following additions and amendments are made to the 1917 Code of the Rules of Interchange, all to become effective July 1, 1918.

Rule 86. New paragraph. M. C. B. standard 60,000 lb. capacity axle, with wheel seat less than the condemning limit for such axle, but above the condemning limit for non-M. C. B. standard axle, may be used until October 1, 1920, to replace M. C. B. standard 60,000 lb. capacity axle with wheel seat less than the condemning limit for such axle, but above the condemning limit for non-M. C. B. standard axle. (This paragraph abrogates the first interpretation shown under Rule 86, page 109.)

Rule 87. New paragraph. In order that repairs to cars may be expedited as fully as possible, foreign or private line cars may be repaired by the handling line by using material from their own stock instead of ordering material from car owner, as prescribed by Rule 122, in which event the repairing line is absolved from all responsibility for the cost of standardizing repairs thus made.

When wrong repairs are made, using materials which the repairing line should carry in stock, as prescribed by Rule 122, defect card should be issued to cover both labor and material. (This provision supersedes the interpretations under Rule 122 in Circular No. 15, dated October 31, 1917, and Circular No. 19, dated December 20, 1917, and is also to be considered as an exception to Rule 13.)

Further Details of the Standard Car and Locomotive Orders

The orders for specialties originally placed for the order of 1,025 locomotives have been extended proportionally for 500 ordered later. Of the latter order, which included 130 light Mikado locomotives from the American Locomotive Company, 50 have been changed to the heavy Mikado type. These are to be delivered to the Chicago, Milwaukee & St. Paul, which desired the change. Fifteen additional locomotives have been ordered from the Lima Locomotive Corporation.

The Central Advisory Purchasing Committee, of the Railroad Administration, has awarded the orders for brick arches for the 1,415 locomotives recently ordered, to the American Arch Company.

The three-point suspension and supports for brakebeams for the locomotives and the 100,000 freight cars have been ordered from the Chicago Railway Equipment Company.

Orders for headlight cases for the United States standard

locomotives have been placed as follows: 765, Schroeder Headlight & Generator Company; 500, Handlon & Buch; 500, Adams & Westlake.

Water gage cocks for the 1,415 standard locomotives have been ordered from the Nathan Manufacturing Company. Superheaters for the locomotives will be built by the locomotive builders on a royalty basis. The orders for all of the specialties for both the cars and the locomotives have now been placed.

The allotment of orders for the journal boxes for the government standard freight cars, as announced last month, has been changed. Journal boxes for 4,000 cars have been ordered from McCord & Co., and the order from the Haskell & Barker Car Company has been reduced from 8,000 to 6,000. A typographical error in last month's issue gave orders for journal boxes for 32,500 of the standard cars to the Union Spring & Manufacturing Company. This should have been given as 2,500 cars only.

MEETINGS AND CONVENTIONS

American Railway Tool Foremen's Association.—The executive committees of the American Railway Tool Foremen's Association and the Supply Association at a meeting held in Chicago on March 16, 1918, unanimously moved that the 1918 convention be postponed and the Year Book not published on account of the war.

Traveling Engineers' Association.—In connection with the annual meeting of the Traveling Engineers' Association to be held at the Hotel Sherman, Chicago, September 10 to 13, the Railway Equipment Manufacturers will have an exhibit. Applications for space are being sent out this week by C. W. Floyd Coffin, of the Franklin Railway Supply Company, 50 Church street, New York, who is secretary of the supply men's body. In his letter to the supply men, Mr. Coffin says: "The Traveling Engineers' Association expects its convention this year to be the largest in attendance it has ever held, and I believe it is equally important that the various supply companies will be well represented at this time, as this is the first opportunity afforded them to present their material to the many representatives of the United States Railroad Administration who are sure to be in attendance."

The following list gives names of secretaries, dates of next or regular meetings and places of meeting of mechanical associations:

AIR BRAKE ASSOCIATION.—F. M. Nellis, Room 3014, 165 Broadway, New York City.

AMERICAN RAILROAD MASTER TINNERS', COPPERSMITHS' AND PIPEFITTERS' ASSOCIATION.—O. E. Schlink, 485 W. Fifth St., Peru, Ind.

AMERICAN RAILWAY MASTER MECHANICS' ASSOCIATION.—V. R. Hawthorne, 746 Transportation Bldg., Chicago.

AMERICAN RAILWAY TOOL FOREMEN'S ASSOCIATION.—R. D. Fletcher, Belt Railway, Chicago.

AMERICAN SOCIETY FOR TESTING MATERIALS.—Prof. E. Marburg, University of Pennsylvania, Philadelphia, Pa.

AMERICAN SOCIETY OF MECHANICAL ENGINEERS.—Calvin W. Rice, 29 W. Thirty-ninth St., New York.

ASSOCIATION OF RAILWAY ELECTRICAL ENGINEERS.—Joseph A. Andreuccetti, C. & N. W., Room 411, C. & N. W. Station, Chicago.

CAR FOREMEN'S ASSOCIATION OF CHICAGO.—Aaron Kline, 841 Lawlor Ave., Chicago. Second Monday in month, except June, July and August, Hotel Morrison, Chicago.

CHIEF INTERCHANGE CAR INSPECTORS' AND CAR FOREMEN'S ASSOCIATION.—W. R. McMahon, New York Central, Albany, N. Y.

INTERNATIONAL RAILROAD MASTER BLACKSMITHS' ASSOCIATION.—A. L. Woodworth, C. H. & D., Lima, Ohio.

INTERNATIONAL RAILWAY FUEL ASSOCIATION.—J. G. Crawford, 542 W. Jackson Blvd., Chicago.

INTERNATIONAL RAILWAY GENERAL FOREMEN'S ASSOCIATION.—William Hall, 1061 W. Wabash, Winton, Minn.

MASTER PULVERMAKERS' ASSOCIATION.—Harry D. Vought, 95 Liberty St., New York.

MASTER CAR BUILDERS' ASSOCIATION.—V. R. Hawthorne, 746 Transportation Bldg., Chicago.

MASTER CAR AND LOCOMOTIVE PAINTERS' ASSOCIATION OF U. S. AND CANADA.—A. P. Dane, B. & M., Reading, Mass.

NIAGARA FRONTIER CAR MEN'S ASSOCIATION.—George A. J. Hoehereche, 623 Brisbane Bldg., Buffalo, N. Y. Meetings, third Wednesday in month, Stabler Hotel, Buffalo, N. Y.

RAILWAY STOREKEEPERS' ASSOCIATION.—J. P. Murphy, Box C, Collinwood, Ohio.

TRAVELING ENGINEERS' ASSOCIATION.—W. O. Thompson, X. Y. C. R. R., Cleveland, Ohio. Next meeting, September 10, 1918, Chicago.

PERSONAL MENTION

FEDERAL ADMINISTRATION APPOINTMENTS

HIRAM W. BELNAP, who was recently appointed manager of the safety section of the Division of Operation, United States Railroad Administration, resigned his position as chief of the Bureau of Safety of the Interstate Commerce Commission on July 1, to devote his entire time to the work of the safety section. Mr. Belnap will supervise the building up of an effective safety organization on all of the railroads under federal control. He had been with the Interstate Commerce Commission for 15 years, for seven years as chief of the Bureau of Safety, and for the eight preceding years as inspector of safety appliances.

C. H. BILTY, mechanical engineer of the Chicago, Milwaukee & St. Paul, with office at Milwaukee, Wis., has been appointed mechanical engineer on the staff of the regional director of Northwestern railroads, with office at Chicago, succeeding W. R. Wood.

J. T. CARROLL has been appointed mechanical assistant to Charles H. Markham, regional director of the Allegheny region, United States Railroad Administration. Mr. Carroll was assistant general superintendent motive power of the Baltimore & Ohio, at Baltimore, Md.

ROBERT COLLETT, who was fuel supervisor and superintendent of locomotive performance of the Frisco Lines previous to 1914, and since that time assistant manager of the railroad department of the Pierce Oil Corporation, has been appointed assistant manager of the Fuel Conservation section of the United States Railroad Administration, with supervision over the Eastern region, and headquarters at New York.

C. S. GOLDBOROUGH, assistant to president of the Erie, at New York, has been appointed assistant to the federal manager with jurisdiction over the purchasing and stores department, and will perform other duties assigned to him.

O. H. WOOD, assistant purchasing agent of the Great Northern at Seattle, Wash., has been appointed special representative of the Central Advisory Purchasing Committee of the Railroad Administration, with headquarters in the same city. He will co-operate with that committee and assist in procuring railroad requirements of fir lumber.

GENERAL

W. ALEXANDER, superintendent motive power of the Chicago, Milwaukee & St. Paul lines east of Moberge, S. D., has resigned to enter the motor service department of the war department.

R. W. ANDERSON, division master mechanic of the Chicago, Milwaukee & St. Paul, at Miles City, Mont., has been promoted to assistant superintendent motive power of the middle district, with headquarters at Milwaukee shops, Milwaukee, Wis., succeeding A. N. Lucas.

E. J. BRENNAN, general master mechanic of the Baltimore & Ohio at Pittsburgh, Pa., has been appointed superintendent of motive power of the Chicago, Milwaukee & St. Paul lines east of Moberge, S. D., with headquarters at Milwaukee, Wis., succeeding W. Alexander.

F. H. CLARK, general superintendent of motive power of the Baltimore & Ohio, has been appointed general superintendent, maintenance of equipment, of the Baltimore & Ohio (eastern lines and New York terminals), the Western

Maryland, the Cumberland Valley, the Cumberland & Pennsylvania, and the Coal & Coke, with headquarters at Baltimore, Md.

H. K. FOX, engineer of tests of the Chicago, Milwaukee & St. Paul, has been appointed mechanical engineer, with headquarters at Chicago, succeeding C. H. Bilty.

GEORGE P. KEMPF, master mechanic of the Dubuque division of the Chicago, Milwaukee & St. Paul, has been appointed engineer of tests, with headquarters at Milwaukee, Wis., succeeding H. K. Fox.

C. W. KINNEAR, assistant master mechanic on the Southwest system of the Pennsylvania Western Lines at Dennison, Ohio, has been appointed assistant engineer of motive power of the Central system, with headquarters at Toledo, Ohio, succeeding R. H. Flinn.

M. J. MCCARTHY, superintendent of motive power of the Baltimore & Ohio, with office at Cincinnati, Ohio, has been appointed superintendent maintenance of equipment of the western lines, with office at Cincinnati.

J. E. MECHLING, master mechanic on the St. Louis system of the Pennsylvania Western Lines, with headquarters at Terre Haute, Ind., has been promoted to superintendent motive power of the same system and with the same headquarters, succeeding W. C. Arp, retired.

L. B. MOREHEAD, shop inspector of the Chicago, Indianapolis & Louisville, has been appointed mechanical engineer, with headquarters at Lafayette, Ind., succeeding K. J. Lamcool, who has entered military service in the Quartermasters department.

A. N. OSIBERG, mechanical inspector of the Chicago, Burlington & Quincy, with headquarters at Chicago, has been appointed mechanical engineer for valuation, with the same headquarters, succeeding W. H. Davis, who has gone into the department of inspection and tests of the Railroad Administration at Washington, as office engineer.

H. A. SCHNITZ has been appointed inspector of tonnage rating of the Chicago, Rock Island & Pacific, succeeding C. M. Rogers, promoted.

J. F. SHEEHAN, superintendent of motive power of the Atlanta, Birmingham & Atlantic, continues under the United States Railroad Administration in the same position on that road, and is also superintendent motive power of the Georgia Railroad, the Atlanta & West Point, the Western Railway of Alabama, the Charleston & Western Carolina and the St. Louis-San Francisco lines east of the Mississippi river.

R. E. SMITH, general superintendent motive power of the Atlantic Coast Line, with office at Wilmington, N. C., has been appointed also general superintendent motive power of the Winston-Salem Southbound.

W. F. WALSH has been appointed assistant superintendent of motive power of the southern district of the Chicago, Milwaukee & St. Paul, with headquarters at Dubuque, Iowa, succeeding J. J. Connor, resigned. Mr. Walsh was traveling mechanical expert for the Galena Signal Oil Company, with headquarters in Chicago.

W. R. WOOD, formerly mechanical engineer of the Great Northern, and more recently mechanical engineer on the staff of the regional director of Northwestern railroads, has returned to the Great Northern as mechanical engineer at St. Paul.

O. C. WRIGHT, master mechanic on the Pennsylvania Western Lines, Southwest system, with headquarters at Logansport, Ind., has been promoted to superintendent on the Central system, with headquarters at Cambridge, Ohio, succeeding H. K. Brady.

MASTER MECHANICS AND ROAD FOREMEN OF ENGINES

J. S. ALLEN, general foreman of the Canadian Pacific, at North Bay, Ont., has been appointed division master mechanic of the Sudbury division, succeeding C. A. Wheeler, promoted.

T. J. CLAYTON has been appointed master mechanic of the Texarkana & Fort Smith, with headquarters at Texarkana, Texas, succeeding A. D. Williams, resigned.

T. B. FARRINGTON, assistant master mechanic of the Pennsylvania Western Lines, Southwest system, with headquarters at Columbus, Ohio, has been promoted to master mechanic of the Michigan division, with headquarters at Logansport, Ind.

R. H. FLINN, assistant engineer of motive power of the Pennsylvania Western Lines, Central system, at Toledo, Ohio, has been appointed master mechanic on the St. Louis system, with headquarters at Terre Haute, Ind., succeeding J. E. Mechling.

J. C. GARDEN, master mechanic of the Grand Trunk at Battle Creek (Mich.) shops, has been appointed master mechanic of the Stratford (Ont.) shops in place of C. Kelso, assigned to other duties.

J. HAY has been appointed master mechanic of the Grand Trunk Lines in New England, with office at Portland, Me.

T. H. HOGAN has been appointed master mechanic of the Memphis line of the Louisville & Nashville, with headquarters at the Paris (Tenn.) shops, succeeding F. J. Monahan.

C. A. KOTHE, master mechanic of the Erie, with office at Port Jervis, N. Y., has been transferred as master mechanic to Brier Hill, Youngstown, Ohio.

F. V. McDONNELL, master mechanic of the Pennsylvania Lines West of Pittsburgh, Northwest system, at Pittsburgh, Pa., has been appointed master mechanic, with office at Ft. Wayne, Ind., succeeding E. E. Griest, resigned.

B. YOUNG has been appointed acting assistant road foreman of engines for the Western division of the Pennsylvania Lines West.

G. J. MESSER, master mechanic of the Sioux City and Dakota division of the Chicago, Milwaukee & St. Paul, has been transferred to the Dubuque division, with headquarters at Dubuque, Iowa, in place of George P. Kempf.

F. J. MONAHAN, master mechanic of the Memphis line of the Louisville & Nashville, has been appointed master mechanic of the Birmingham division, with headquarters at the Boyles (Ala.) shops.

J. R. RIGGS, general foreman of locomotive repairs on the Pennsylvania Western Lines, St. Louis system, with headquarters at Logansport, Ind., has been appointed master mechanic on the Central system, Toledo division, with headquarters at Toledo, Ohio, succeeding G. E. Sisco, transferred.

A. J. VOGLER, general foreman at the passenger terminal of the Chicago, Burlington & Quincy at Western avenue, Chicago, has been promoted to the position of master mechanic of the Sioux City and Dakota division, with headquarters at Sioux City, Iowa, succeeding G. J. Messer.

CAR DEPARTMENT

GEORGE WINK, foreman of the Weehawken (N. J.) freight yards of the Erie, has been appointed joint car inspector at Weehawken.

SHOP AND ENGINEHOUSE

A. N. LUCAS, assistant superintendent motive power of the middle district of the Chicago, Milwaukee & St. Paul, has

been appointed shop superintendent, with jurisdiction over the locomotive department of the Milwaukee shops.

PURCHASING AND STOREKEEPING

HARVEY DE CAMP, purchasing agent of the Gulf & Ship Island, with office at Gulfport, Miss., has been appointed purchasing agent also of the Mississippi Central and the New Orleans Great Northern, with office at Hattiesburg, Miss.

F. H. FECHTIG, purchasing agent of the Atlantic Coast Line and the Charleston & Western Carolina, with office at Wilmington, N. C., has been appointed also purchasing agent of the Winston-Salem South-bound.

W. S. GALLOWAY, assistant purchasing agent of the Baltimore & Ohio, with office at Baltimore, Md., has been appointed purchasing agent for the western lines, with headquarters at Baltimore.

E. W. GRICE, assistant to president of the Chesapeake & Ohio, has been appointed manager of purchases, stores and safety, with headquarters at Richmond, Va.

L. M. JONES, assistant to the general manager of the Norfolk Southern, with office at Norfolk, Va., has been appointed purchasing agent.

A. S. McKELLIGON, storekeeper of the Southern Pacific, at Sacramento, Cal., has been appointed general storekeeper, with headquarters at San Francisco, Cal., succeeding H. G. Cook, resigned.

RALPH P. MOORE, purchasing agent of the Duluth & Iron Range, with headquarters at Duluth, Minn., has had his jurisdiction extended over the Duluth, Missabe & Northern.

ROBERT B. PEGRAM, executive general agent of the Southern Railway, at Memphis, Tenn., has been appointed general purchasing agent of the Southern Railway System, the Alabama & Vicksburg, the Georgia, Southern & Florida, the Carolina, Clinchfield & Ohio and the Carolina, Clinchfield & Ohio of South Carolina, with headquarters at Washington, D. C. Mr. Baker was born on August 22, 1874, at Marion, Ala., and was educated in private schools at Memphis, Tenn. In July, 1890, he began railway work with the Southern Railway. In 1895 and 1896 he was chief clerk of the Memphis Freight Bureau, and later in 1896 served as chief clerk to the assistant general freight agent of the Illinois Central, at Memphis. In January, 1904, he was appointed soliciting freight agent of the Southern Railway, subsequently served as commercial agent at the same place, and later as chief clerk to the vice-president at St. Louis, Mo. In December, 1905, he was appointed assistant general freight agent at Nashville, Tenn., and in April, 1907, he was promoted to general freight agent at the same place, subsequently serving as general freight agent at Charleston, S. C. On May 1, 1910, he was appointed general agent, executive department, with office at Charleston, and since January, 1917, was executive general agent with office at Memphis until he received his recent appointment.

W. A. STARRITT, purchasing agent of the Carolina, Clinchfield & Ohio and the Carolina, Clinchfield & Ohio of South Carolina, at Johnson City, Tenn., has been appointed local purchasing agent, with headquarters at Johnson City.

M. W. STEVENS has been appointed purchasing agent and storekeeper of the Grand Trunk Lines in New England, with office at Portland, Me.

C. B. WILLIAMS, purchasing agent of the Central of New Jersey, at New York, has been appointed purchasing agent of that road, also of the Philadelphia & Reading, the New York & Long Branch, the Atlantic City and the Port Reading, with headquarters at Philadelphia, Pa.

COMMISSION APPOINTMENT

JOHN M. HALL, formerly district inspector of locomotive boilers for the Interstate Commerce Commission and recently supervisor of equipment in the locomotive section of the Railroad Administration, has been appointed assistant chief inspector of locomotive boilers of the Interstate Commerce Commission, succeeding A. G. Pack, promoted.

ALONZO G. PACK, assistant chief inspector of the Bureau of Locomotive Boiler Inspection, Interstate Commerce Commission, has been nominated by President Wilson chief inspector, succeeding Frank McManamy. Mr. Pack was born on July 22, 1865, at Princeton, W. Va. His first 15 years were spent on a farm, and in 1880 he entered the service of the Norfolk & Western on construction work. In 1882 he went to the Chesapeake & Ohio, as an apprentice in the boiler shop. He also served on that road as a brakeman. In 1887 he went to Denver, and worked for the Union Pacific and the Denver & Rio Grande, as locomotive fireman. In 1895 he became connected with the Colorado Midland as an engineman. In 1900 he went to the Colorado Springs & Cripple Creek, serving as locomotive engineman until 1911, when he was appointed district inspector of locomotive boilers of the Interstate Commerce Commission, with headquarters at Denver, Colo. In 1914 he was promoted to assistant chief inspector.

WILFRED P. BORLAND has recently been promoted from assistant chief to chief of the Bureau of Safety of the Interstate Commerce Commission, succeeding H. W. Belnap. Mr. Borland has been in the service of the Interstate Commerce Commission for 16 years, having become identified with its safety appliance work when it was first established under the late secretary of the commission, E. A. Moseley. Mr. Borland entered railroad service in 1876 as a brakeman on the Flint & Pere Marquette, and in about a year became fireman. He was later fireman and engineman on this road, the Denver & Rio Grande, and the Northern Pacific, making a total of about 20 years in railroad service, which he left in 1896. He was then a stenographer at the Mare Island Navy Yard, and became connected with the Interstate Commerce Commission in 1902. He was for a number of years inspector clerk in the safety appliance department, and later was secretary of the Block Signal and Train Control Board. On February 5, 1914, he was appointed assistant chief inspector of safety appliances



A. G. Pack.



W. P. Borland.

SUPPLY TRADE NOTES

James M. Hopkins, chairman of the Camel Company, Chicago, has accepted a position with the Priorities Committee of the War Industries Board. Mr. Hopkins will reside in Washington.

Lieut. J. G. Russell, of the Royal Flying Corps, formerly traveling inspector for the American Steel Foundries, with headquarters at Chicago, was killed in action on the Italian front, June 15.

John F. Kane, assistant secretary of the Pullman Company, was elected secretary at a meeting of the board of directors of that company, held on June 10, to succeed A. S. Weinsheimer, deceased.



J. F. Kane

Mr. Kane is a native of Ingersoll, Ont. He received his early education in the schools of that city, following which he came to Chicago. On September 1, 1891, he entered the service of the Pullman Palace Car Company, now the Pullman Company, as a telegraph operator. In 1904 he was appointed paymaster with headquarters at Chicago, in which position he remained until 1913, at which time he was elected assistant secretary.

He continued in that position until his recent election as secretary with headquarters at Chicago, as mentioned above.

The United States Metallic Packing Company, Philadelphia, Pa., announces that it no longer represents the Watertown Specialty Company for the sale of that company's automatic cylinder cock.

Frank C. Hasse, district superintendent of the Oxweld Railroad Service Company, with headquarters at Chicago, has been commissioned a captain in the quartermasters corps of the National Army.

The Lagonda Manufacturing Company of Springfield, Ohio, has moved its Kansas City office from 314 Dwight building to 306 Elmhurst building. F. H. Penberthy is in charge as district sales manager.

The Bird-Archer Company has moved its Chicago office from room 566 to room 1105 Peoples Gas building, to obtain larger space. This company has recently established a plant in Chicago and one at Cobourg, Ont.

The Austin Company, Cleveland, Ohio, has opened a new branch office at Chicago. This new office is the direct result of an increased volume of business from the middle west section. The location is 437 Peoples Gas building.

The Ralston Steel Car Company, Columbus, Ohio, has abolished its Chicago office in the Peoples Gas building. Ford S. Clark, who has been the representative at Chicago, has been appointed sales representative at Philadelphia, Pa.

L. C. Sprague, of the railroad department of the H. W. Johns-Manville Company, at New York, has been appointed

special representative of the Chicago Pneumatic Tool Company in connection with the sale of pneumatic tools to railroads.

George A. Post, president of the Standard Coupler Company, New York, and honorary vice-president of the Railway Business Association, has been elected chairman of the Railroad Committee of the Chamber of Commerce of the United States.

The firm of Koch & Sandidge, with offices at 19 South Wells street, Chicago, was recently formed to handle the sales engineering work for the line of "Jiffy" cutting tools and similar products manufactured by the Universal Tool & Appliance Company, of Milwaukee, Wis.

Frank Lucas DeArmond, who for a number of years has been an officer of the Protectus Paint Company, Philadelphia, Pa., has severed his connection with that company for the duration of the war, having been appointed a captain in the quartermaster's corps, construction division.

The Baldwin Locomotive Works, according to an announcement made on July 9, is planning the immediate construction of a new plant at East Chicago, with an estimated cost of \$5,000,000. Specifications for various buildings are now out calling for 12,000 tons of structural steel.

A. S. Goble, sales representative of the Baldwin Locomotive Works and the Standard Steel Works at Chicago, has been appointed south-western district representative of the same companies at St. Louis, Mo., succeeding C. H. Peterson, who has been transferred to the Chicago office as western district representative.

Edward F. Carry, president of the Haskell & Barker Car Company, has resigned as director of operations of the Shipping Board to become chairman of the Port and Harbor Commission. He will be succeeded on the Shipping Board by J. H. Rosseter, of San Francisco, vice-president and general manager of the Pacific Mail Steamship Company.

Clinton C. Murphy, vice-president of the P. H. Murphy Company, and the Standard Railway Equipment Company, of Chicago, died on July 13, in that city. Mr. Murphy was born at Cumberland, Md., on June 5, 1875, and was educated at Smith Academy, St. Louis, Mo. After completing his education he entered the employ of the Cairo Short Line as a machinist apprentice. In 1898 he entered the railway supply business as a representative of the Murphy Roofing Company at St. Louis, following which he moved to Chicago, on his election as vice-president of the Standard Railway Equipment Company. In 1915 he



C. C. Murphy

organized and was made president of the Union Metal Products Company. He was also interested in the Imperial Appliance Company and the Pressed Steel Manufacturing Company, both of Chicago.

At a directors' meeting of the Chicago Pneumatic Tool Company, held June 28, W. P. Pressinger, general manager of sales, with headquarters at Chicago, and W. H. Callan, manager of plants, with the same headquarters, were elected

vice-presidents. Mr. Pressinger's photograph and biography were published in the *Railway Mechanical Engineer* for June.

The Pittsburgh Testing Laboratory announces the removal, on July 1, from its temporary quarters in the B. F. Jones Law building to its new office and laboratory buildings at 612-620 Grant street, Pittsburgh, Pa. The laboratories will be larger and better equipped than those in the company's old quarters, the P. T. L. building at Seventh and Bedford avenues, which were turned over to the government April 1.

Robert Brown Carnahan, Jr., vice-president of the American Rolling Mill Company, Middletown, Ohio, was accidentally killed on June 22. He was educated at the University of Pittsburgh, graduating with the class of 1891. Upon the completion of the university work he became associated with the Dewees-Wood Company at McKeesport, Pa., where he was engaged in research work in connection with gold mine prospects. He remained with that concern until 1899, when he went with the Carnegie Steel Company at its Homestead works, where he was engaged in special work in connection with the manufacture of open hearth steel. In 1900 he entered the service of the American Mill Company as chief chemist and open hearth superintendent at what is now known as its Central works. Under Mr. Carnahan's direction the Armco American ingot iron was developed.



R. B. Carnahan, Jr.

The Quigley Furnace Specialties Company, Inc., has opened a branch office in Pittsburgh at 427 Oliver building, to handle the sale of powdered coal equipment and Hytemplate furnace cement. The powdered coal engineering department will be in charge of L. V. Marso, formerly maintenance engineer of the A. M. Byers Company plant at Girard, Ohio, and the specialties department will be taken care of by J. L. Cummings, Jr., formerly connected with the sales department of the company at New York.

At a meeting of the board of directors on June 28, George W. Wildin was elected general manager of the Westinghouse Air Brake Company, succeeding A. L. Humphrey, resigned. Mr. Humphrey continues as ranking vice-president, and in that capacity will, as heretofore, have general direction of the company's operations in all departments and subsidiary organizations, Mr. Wildin reporting to him. A photograph and sketch of Mr. Wildin's career were published in the April *Railway Mechanical Engineer*.

The Barco Manufacturing Company, Chicago, has placed on the market a type of crosshead and shoe, invented by Charles D. Markel, chief construction inspector of locomotives in the Inspection and Test Section of the United States Railroad Administration. This device, which is known as the Barco crosshead and crosshead shoe, was described in the *Railway Mechanical Engineer*, issue of January, 1917, page 49. The company is prepared to furnish crossheads complete or to sell the shop rights to manufacture the device at the option of the railroads.

CATALOGUES

SHAY GEARED LOCOMOTIVES.—The Lima Locomotive Works, Lima, Ohio, has issued a circular illustrating the Shay geared type of locomotive and enumerating the advantages which they possess over other locomotives.

GRINDING WHEELS.—The National Safety Council, Chicago, has issued a loose-leaf pamphlet on grinding wheels, which describes safe practices with regard to the inspection, storage and mounting of wheels and the condition of machines, hoods and guards.

ELECTRIC METERS.—Bulletin No. 50 issued by the Economy Electric Devices Company, Chicago, illustrates and describes the Sangamo Economy electric meter and its application for regulating the power consumption of electric traction units. The advantage of proper acceleration and the savings to be effected thereby are clearly set forth.

VALVES AND FITTINGS.—A new catalogue of hydraulic valves and fittings has just been issued by the Hydraulic Press Manufacturing Company, Mt. Gilead, Ohio. The book is well written and illustrated, and presents in an attractive way the complete H-P-M line. Four general classes of hydraulic valves are shown; also different types of hydraulic fittings, such as accumulator controls, pressure gages, hydraulic valves, etc. Many of these devices are of improved design and are described for the first time in this catalogue. Copies may be obtained on request.

ELECTRIC WELDING.—A 6-in. by 9-in. 45-page manual entitled "Electric Welding" has been issued by the Wilson Welder & Metals Company, Inc., New York. This manual provides instructions covering the installation, care, operation and maintenance of Wilson electric welding equipment. Also, directions are given regarding the welding of various kinds of metal, the grade of welding wire to be used, the amount of current to employ, etc. Some interesting illustrations are given of the broken cylinders on the converted German steamships which were successfully repaired by the electric welding process.

THE BAKER LOCOMOTIVE VALVE GEAR.—Under this title a book of pocket size, bound in stiff paper covers, has been published by the Pilliod Company, 30 Church street, New York. This publication is a treatise on the Baker locomotive valve gear, which is completely described and illustrated, and for which a large amount of data is given in tabular form as to valve events, proportions of parts, etc. About one-half of the book is devoted to a description of the methods of setting the valves, each step in the explanation being accompanied with an example. Several pages are also devoted to the Sentinel low water alarm, which is manufactured by the Pilliod Company. For general distribution a price of 25 cents is quoted.

LIFTING JACKS.—Catalogue "F," recently issued by the Joyce-Cridland Company, Dayton, Ohio, contains descriptions, illustrations and prices of a complete line of lifting, pulling and pushing jacks. The hydraulic jacks include both inside and outside pump types with a wide range of capacity up to 200 tons. The line of geared screw jacks in capacities of 25 to 75 tons, include types suitable for both bridge and railroad shop work. The line also includes automatic geared jacks, automatic lever jacks, track jacks, telescope screw jacks, traversing bases for lifting jacks and a variety of jacks for special classes of service. Repair parts for the various jacks are illustrated and listed in convenient form for ordering.

Railway Mechanical Engineer

Volume 92

September, 1918

No. 9

CONTENTS

EDITORIALS:

Analyze Carefully Salvageable Items.....	487
The Measure of Fuel Is Weight—Not Money.....	487
How the Freight Car Situation Is Improving.....	487
Effect of the Wage Increase on Piecework.....	488
The Wage Increase and Supervising Foremen.....	488
Increase in Wages for the Railway Shop Men.....	488
Good Illumination Promotes Shop Efficiency.....	489
New Books.....	489

COMMUNICATIONS:

Save the Rubber Gaskets.....	490
Don't Reduce Washout Time Too Much.....	490
T. W. Gives Some Advice.....	490

GENERAL:

Heavy Standard Mikado Locomotives.....	491
Interesting News from the Railroad Administration.....	494
Fuel Conservation Section Activities.....	495
The Time Lost in Slowdowns.....	497
Fourth Liberty Loan Appeal.....	501
Results of Road Tests of N. & W. Mallet Locomotives.....	502
M. K. & T. Pulverized Coal Tests.....	503
Reclamation on the Southern Pacific.....	505

CAR DEPARTMENT:

Effect of Holes in the Sides of Box Bolsters.....	507
Brake Pipe Leakage.....	508
Large Capacity Wooden Hooper Car.....	509

Allocation of the 100,000 Standard Cars.....	512
Save Fuel by Oxy-Air.....	512
Settlement for Destroyed Cars.....	513
The Design of Offset Beams.....	514
Railroad Administration Paint Order.....	517
Why Don't Daddy Come Home.....	517

SHOP PRACTICE:

Air Hammer Attachment.....	519
An Efficient Machine for Finishing Crown Stays.....	519
Welding Firebox Patches and Cracks.....	520
Milling Practice in Railway Shops.....	521
Novel Method of Driving Drills.....	524
Jig for Machining Nuts.....	524
Shopmen's Wages Are Increased.....	525
The Cost of Oxy-Acetylene Welding.....	525
A Method of Regulating Shop Output.....	527
Meeting of the Iron and Steel Association.....	529
Tipping Carbon Steel Tools.....	530

NEW DEVICES:

A New Car Jack.....	531
A Self Locking Car Seal.....	532
Stephenson Nut Lock.....	532

GENERAL NEWS:

Notes.....	533
Meetings and Conventions.....	534
Personal Mention.....	535
Supply Trade Notes.....	537
Catalogues.....	538

Analyze Carefully Salvageable Items

A letter by C. J. Ruhland, a locomotive engineer, commenting on the shameful waste of rubber gaskets for air hose couplings, will be found on another page. In the past it has been quite unnecessary to give these minor articles consideration, but there are now certain materials, such as rubber, tin, etc., for which the government has great need, which puts a very different light on the situation. The demands for iron and steel are growing greater every day. We are told that there are several important industries that will have to go without them because the demand is far greater than the supply. Our reclamation program must be completely revised and brought up-to-date. Consideration of the cost of reclamation is in many cases the important factor, but in others the question is whether or not new material can be obtained under any consideration.

The Measure of Fuel is Weight— Not Money

In the past all fuel economy campaigns have been conducted on the basis of money saved. Today we are asked, and beseeched, and forced to save fuel for fuel's sake alone. The question now is not, can we get the money to buy the fuel, but can we get fuel to burn. The demands of the war industries, of the ships that carry our munitions and supplies, and of our Allies have taxed the available fuel resources of this country to the limit. Our government has seen to it that the price of fuel has been held down in order that every one may buy. It is our individual duty to see that none of it is wasted that every one may be supplied. The railroads use between 25 and 30 per cent of the coal

mined in this country. The possibilities in economies are great—so great that the Railroad Administration has considered it necessary to appoint a Fuel Conservation Section which is attached to the Division of Operation. There is not a reader of this paper who cannot assist. Wasted power, wasted heat, wasted air, and wasted light all mean wasted fuel. Nothing is too small to be considered.

The Freight Car Situation Is Improving

Perhaps never before in the history of American railroading has the freight car repair situation been as serious as it has been during the past six months. The winter with its severe cold weather, coupled with inadequate shop facilities, created conditions under which it was very difficult properly to repair the cars. The spring and early summer saw these conditions further aggravated by a shortage of men. It has been extremely difficult to hold the men with the promises of better pay even though these promises were backed by the government. Now that the wage schedule has been definitely decided there has been a marked improvement in the conditions. Men who have expressed the desire to transfer into other departments are now willing to stay in the car department. The old men are coming back. There is still, however, a large amount of work to be done.

Every means must be taken to keep the largest possible number of cars in service. Some roads are finding it expedient to send repair gangs to congested points to make the light repairs to the cars in order to get them over the road. In hump yards car inspectors going over a string of

cars are told to make what repairs are possible. It will require the ingenuity of our ablest car men successfully to cope with the situation. The greatest amount of publicity should be given to methods now used to reduce the number of bad order cars. We shall welcome suggestions from any of our readers in regard to this work in order that we may pass them along for the benefit of others.

How Can Traveling Engineers Help Win the War

The Traveling Engineers will meet in Chicago to hold their 26th annual convention this month. The association has been authorized by the Railroad Administration to hold this meeting because of the realization that the traveling engineer, or road foreman of engines, has a very important part to play in the successful operation of our complex transportation system. The work of the traveling engineer throws him into intimate contact with the men who drive the trains, the men in whose charge is placed a machine worth anywhere from \$50,000 to \$100,000 and which consumes a great amount of coal; with the men whose duty it is to haul the munitions and supplies to the seaboard for shipment. In his daily contact with the enginemen and firemen the traveling engineer can, by careful coaching and instruction, exert a strong influence which will help greatly towards winning the war. He should infuse his enthusiasm and patriotism into the engine crews. He should make them realize how necessary it is to save fuel; how, because of the difficulty to get sufficient men properly to maintain the power, it should be handled carefully; he should show them what an important part they are playing in the prosecution of the war, and carry the message of his superior officers to the men on the firing line in such a manner that they will willingly and cheerfully respond to the demands made upon them. The traveling engineer has a greater opportunity than he ever had before and under existing conditions, with a shortage of fuel and material, his position is of exceptional importance. Problems concerning the new conditions at the convention will be discussed and the lessons there learned should be carried home and used to good advantage.

Effect of the Wage Increase on Piecework

While supplement No. 4 to general order No. 27, has granted a generous increase in wages to railway shopmen for the purpose of attracting workmen to the railway field in the hope of increasing the output of the shops, it has, by the manner in which these increases have been awarded, practically eliminated piecework and with it the incentive for the men individually, to increase their output. By not increasing piecework rates in proportion to the day work rates and by guaranteeing a minimum hourly rate of 68 and 58 cents to the men in the shops, the piecework prices are now so low, comparatively speaking, that but few men will desire to continue to work under that system.

On a number of railroads piecework, or some sort of bonus system has been developed to a high degree, resulting in greatly increased output. It has been stated that a piecework shop will turn out 33 per cent more work than a straight day-work shop. With the incentive removed for the men to work under the piecework system, it is evident that some of the beneficial effects anticipated by the wage increase will be nullified. Those to whom the advantages of piecework have been demonstrated practically should bring pressure to bear on the Railroad Administration for the sake of increased shop output and greater efficiency per man.

If the Railroad Administration should decide to perpetuate the piecework system by granting an increase in the piece-

work rates, and should at the same time see to it that the matter is handled in such a way that the men will have explicit confidence in the schedules and know that, regardless of how much they earn, the piecework prices will not be cut, there is no question but that a material increase in shop production will be obtained.

The Wage Increase and the Supervising Foremen

It was rather surprising to observe how badly the matter of increased wages to the shop foremen was handled in the recent wage revision. Gang leaders were granted five cents an hour above the workmen under their employ which is, of course, a splendid way of handling that particular class of men. The foremen of higher grades, however, were granted an increase of \$40 a month. This was manifestly unfair inasmuch as many roads have postponed granting the foremen increases until definite action was taken by the Railroad Administration. Other roads have advanced the foremen with the men. Thus adding \$40 to the existing salary of all foremen still maintains an unjust inequality. It is understood that this matter is still under consideration, and it is hoped that some uniformity of wage will be adopted and that the men in the supervising positions will be paid enough to hold them in that capacity and to keep them satisfied. With a weakened organization due to the high turnover of the shop forces, the need of efficient and competent supervision was never more greatly needed than it is today.

Increase in Wages for the Railway Shopmen

To those of the railway shop employees who have had sufficient confidence in the promises of the Railroad Administration regarding the increase in wages to remain in railway service, supplement No. 4 of general order No. 27 must be received with a great deal of satisfaction. A minimum of 58 cents an hour for the experienced carmen, and 68 cents for the experienced locomotive mechanics should fully satisfy these men. The manner in which these increases have been applied to the employees below the most experienced grades is considered entirely fair. These men are not only paid well, but are given some incentive for remaining in the employ of the railroads by being promised an increase for every year, up to four years, they remain in the railroad's employ.

To those who have remained with the railroads since the beginning of the year, a large bonus in the form of back pay is due. To some men, particularly those in the car department, this bonus will amount to a great deal. Take a car inspector, for instance, who has been working at the rate of 35 cents an hour straight time; in a thirty-day month, working 12 hours a day, he would receive \$126. With time and a half for overtime over eight hours, and for Sunday, at the new rate of 58 cents an hour this same man will now receive \$252.88—an increase of one hundred per cent. Further, this same inspector will receive over \$1,000 back pay, including the month of August. This, perhaps, represents the greatest increase to any of the men affected. There is, perhaps, no other employee in the mechanical department that is deserving of as much consideration. The *Railway Mechanical Engineer* has always contended that the car inspector has been greatly underpaid. The wages of the shopmen on the locomotive side have of necessity been increased from time to time in order to hold men, and while the new rates represent very nearly one hundred per cent increase over those in effect three or four years ago, the net change from the conditions as they existed the early part of this year, will only be about 30 per cent.

The question which naturally arises in the minds of the

shop supervisors and of the railway mechanical department officers, is—What will be the effect of this increase on shop output? Of course a larger number of men will be attracted to railway work. But will they work full time? There are some classes of men who cannot stand prosperity—nor a bank account. When they have plenty of free money on hand they feel uneasy until it is spent. It is this class that must be carefully watched if the desired effect of the increase—namely, to increase the output of the shops by attracting more expert labor—is not to be neutralized. It will take considerable missionary work on the part of the supervising officers to keep these men on the job. The foremen particularly should co-operate in this work.

There are plenty of ways in which this extra money can be spent to good advantage. There is no better investment for the workman than the purchase of government War Saving Stamps, or Liberty Loan Bonds. The fourth loan, for the largest amount yet requested by the government, is soon to be floated. The men should be encouraged to hold on to the surplus funds until the opportunity comes for subscribing to that loan. If the workmen of their own volition do not remain at work, there is the danger of conscription of labor which the public will demand if the men attempt to take advantage of their strategic position and slight the work. This none of us want and if every man will keep before him President Wilson's Labor Day address and bring himself to believe, as he rightfully should, that this war is *his* war there should be no occasion for any such measures.

Good Illumination Promotes Shop Efficiency

In a recent article a representative of an accident insurance company estimated that twenty-five per cent of all the accidents occurring in and about industrial plants in the United States were due to poor lighting. It has also been estimated that the entire cost of adequately lighting all the industries of this country would be less than the yearly cost of accidents now occurring due to poor illumination. As a safety measure alone good lighting is economical. There are other reasons why railroad shops should have efficient illuminating systems. During the winter the shops operate a large part of the time by artificial light, and unless proper illumination is furnished the output will be far below that secured when working by natural light. The extent to which lighting affects production is shown by the case of a large factory in which individual incandescent lamps were replaced by a system of general illumination. The output per man increased sixteen per cent, which was attributed solely to the change in the lighting system.

An inspection of a few typical railroad shops will make it evident that most of the lighting installations were made with great regard for saving electricity, but with little thought of the effect of lighting on shop efficiency. The ordinary drop light, even when properly maintained, provides poor illumination. If a film of grease is allowed to accumulate on the globes the efficiency is reduced forty or fifty per cent. A good lighting system should provide even distribution of light of the proper intensity, varying with the nature of the work. The light should not flicker and there should be no brilliant source of light within the field of vision. Localized lighting is unsatisfactory except as a supplement to general illumination.

By comparison with the cost of wages the expense of adequate lighting is almost negligible. The cost of current for this purpose amounts to only about one per cent of the labor cost. A saving of two to five minutes time per day for each worker will more than pay the cost of the installation. Under these conditions there are many shops and roundhouses where improved lighting systems will bring large returns.

NEW BOOKS

Proceedings of the Air Brake Association.—Edited by F. M. Nellis, secretary. 275 pages, 6½ in. by 8½ in., illustrated, bound in cloth. Published by the association, 165 Broadway, New York.

This book contains the proceedings of the twenty-fifth annual convention of the Air Brake Association which was held at Cleveland, Ohio, May 7 to 9, 1918. The subjects discussed at this meeting were slack action in long passenger trains; the safe life of an air brake hose; the best methods of preparing air brakes at terminals to avoid train shocks and break-in-twos; 8½-in. cross-compound compressor maintenance; the feed valve—its operation and maintenance; M. C. B. brake stenciling for cleaning, etc.; and changes in recommended practice.

The Calorific Value of Fuels.—By Herman Poole, F. C. S., third edition, rewritten by Robert Thurston Kent, M. E., 267 pages, illustrated, 6 in. by 9¼ in., bound in cloth. Published by John Wiley & Sons, Inc., 432 Fourth avenue, New York. Price \$3 net.

This book, while based on the second edition of the late Mr. Poole's work which was published in 1900, has been practically rewritten to incorporate the latest researches not only on coal, but on fuels which to a great extent have replaced or supplemented coal. Revision has been made of some of the work of investigators which was published in the first edition and which now is generally discredited. It has been prepared to cover every industry which uses fuel.

It contains five chapters on the various methods of measuring the calorific value of fuel. Three chapters are given to the discussion of all kinds of solid fuels, liquid fuels and gaseous fuels. One chapter contains a discussion on the combustion of coal, one on the calorific power of coal burned under a steam boiler and another on the analysis and measurement of the products of combustion. An appendix is added, in which are included the A. S. M. E. boiler test code and tables of interest in the study of fuels. The book is well illustrated, and Mr. Kent in his revision has avoided himself of the latest studies made of this subject.

Lubricating Engineer's Handbook. By John Rome Battle, 6 in. by 9 in., 333 pages, bound in cloth. Published by J. D. Lippincott Company, Philadelphia, Pa. Price \$4 net.

This book has been compiled from notes and data collected by the author during a long period of engineering service in the oil business. It covers the whole subject of lubrication and the special requirements of various conditions under which lubricants are required to perform their function. The subject matter has been arranged in five parts. Part I deals with the theory of friction and lubrication, and contains a brief sketch of the origin and history of petroleum. The manufacture of lubricants and grease and the methods of testing lubricants are also described. Part II contains a miscellaneous collection of data most of which will be found useful in making calculations involving the volumes and weights of lubricants. Chapters are also devoted to brief descriptions of various mechanical processes and classes of power machinery in which lubrication is required. The six chapters of Part III are devoted to an elementary discussion of the various types of bearings and methods of lubrication, including descriptions of lubricating equipment and oil house methods, and closing with a chapter on the uses of the steam indicator. Part IV contains 21 chapters, each of which deals with the lubricating problems of a specific type of machinery or prime mover, such as air compressors, automobiles, internal combustion engines, motors and dynamos, railway locomotives and cars, hydro-electric equipment, etc. Cost of lubricants and their specifications are treated in Part V. The book is well illustrated and, while the title is somewhat misleading in that the arrangement, size and binding are not of the usual handbook type, it is probably the most comprehensive collection of thoroughly practical data available on the subject of lubrication.

COMMUNICATIONS

SAVE THE RUBBER GASKETS

OSAWATOMIE, Kan.

TO THE EDITOR:

I have read with much interest the article by Mr. Miller on the prevention of waste vs. reclamation of scrap which was published in the August issue of the *Railway Mechanical Engineer*, on page 407. It made me think of the manner in which air hose gaskets are being wasted. With the high cost of and scarcity of rubber, it is a shame the way the car and locomotive inspectors throw the old gaskets away when replaced. In every switching yard I have been in I have seen rubber gaskets lying around on the ground. I believe this should be stopped. Inspectors should be required to turn them in at the end of their inspection trips. A visit to any yard will show you just how much this amounts to.

C. J. RUHLAND.

DON'T REDUCE WASHOUT TIME TOO MUCH

TRANSCONA, Mar.

TO THE EDITOR:

In his article, entitled "Reducing the Time to Turn Locomotives," which appears in your February number, T. T. Ryan says that: "With a proper hot water washing plant the boiler should be washed and made hot in four hours." I do not consider that it is possible to save as much time in washing out boilers as this statement indicates.

The average locomotive in bad water districts will have from 35 to 45 washout plugs, and possibly hand hole plates in addition. For a thorough washout, these plugs should be removed, and when you consider that it is impossible to get men to work with washout water which is much over 140 deg. F., and that the temperature of the boiler when it comes into the roundhouse is 300 deg. or over, you will acknowledge, I think, that four hours, even with a first-class hot water washout system, is too short a time for washing out and lighting up an engine. Even if the washout part of the work were properly done, the cooling and heating of the boiler would be altogether too rapid, especially with the large amount of welding which we now have in fire boxes.

C. E. BROOKS,

Supt. Motive Power, Grand Trunk Pacific.

T. W. GIVES SOME ADVICE

(With Apologies To Wallace Irwin)

A LAKE MICHIGAN PORT

HON. EDITOR:

I have experience quite an exhilaration recent which I assume to recite for your delectivity. I were idle hunting cooties while sitting in lobby of Whitestone Hotel (this are place where I board when in this city) when I receive message (collect) from friend secretary of a Local 41144 to come quick as he have discover case.

Next evening find me in northern (delete) town at leading hotel while await arrival of friend with sensation. He appear soon and express concern to have me ride with him next day to this city on his regular engine. Next morning I are all equip with overalls, smoke helmet and goggles to endure trouble, as I surmise this are to be no joy ride. I board hog at 1 esconce my person behind enginemane with eyes and ears alee for danger. I think we have about 1/2 mile of cars and late model full crew combination sleeping, dining and bar caboose. We start in on one side, other side follow

soon. First thing I perceive is that this are new kind of cylinder arrangement as she have five exhaust in one cycle. Sec'y explain this by saying rings gone one side which results in two half notes instead of one whole note. I are unable to reply further intelligible so ask why we are favored with decisive drop each revolution. Explanation are to-wit verbatim—"Those flat spots were accumulate by extra crew which come half way down hill, all wheels lock on sand. They ain't bad, however, as I are able to roll them out in three round trip easy." I volunteer soft that it are good job for dentist. Next thing I remark were when drifting down long slope and using air brake gradual. The motion are like starting Ford on cold morning when about half machinery missing or riding camel with long wheel base. Engineer admit with reluctance that wedge can no more be set up without applying liner.

One more idiosyncrasy happen when we turn corners. The locomotive keep on straight line while wheels turn on rail. After a period, front end swing over while tail go over in big jump. I inquire how much lateral exist and friend blush while acknowledge 2 in. ahead, 1 1/2 in. on all drivers and 2 1/4 in. on trailer. The reason for excess behind are account hub liner drop off each side last trip.

This lateral accomplish following result. As we make a turn once she do not seem able to follow rail except all of a sudden. At this instant I alight in full crews lap while engineer land at my feet on shaker post. He immediate climb back to regular position, and apologize to me with subdued eyes. At invitation I return to his seat box with strong resolution about "joy-ride" on antique r.r.

Soon after we arrive at junction and are prepare to go through at 40 mile per hour. Assuming we take straight track I feel secure. However, engine suddenly careen fierce and take turn-out. At same second I. C. C. detector consume six feet between deck and bottom step and are prepare to unload on windward side when engineer grab him by top of head and order him return to cab. I return with clenched fist and eyes ablaze to inquire what he mean by taking turn-out at high speed. All wheels on this side are by now return to rail. He grin effusive and acknowledge ignorance on subject. He explain that he go in some time one way and some time other, and that he propose this time to go straight ahead, but tower man decide different and throw him on cut-off. He say, of course it are not assume to go round there 40 m.p.h. but that since it are happen, he realize how much better engine ride. He explain that all lateral have remove to one side, which avoid tail-slap experience previous, and make ride around curve smooth to compare. I have resolve to stand up remainder of trip and alight when first see city car. We soon approach ship-canal with draw-bridge and account block are require to stop. I collect baggage and set date for eight o'clock my hotel.

When friend secretary approach me at 8 kp. he appear combination sheepish and serious. I resolve to do talking and recite following:

"I have assume you retain me in capacity friend instead of Federal detector, therefore my advice are so. Arrange compact yourself, fireboy and full crew. Next time you approach ship canal in dark or fog with open bridge, see white light, then open wide on beast. Just before approach cruel waters, reverse, throw her over to big hole and unload. SPURLOS VERSANKT—you will have new engine next trip or new job. Good night."

Yours truly,

TOBESURA WENO.

COMPARATIVE EVAPORATION OF OIL, COAL AND GAS.—According to the United States Geological Survey, 1 lb. of oil, under favorable conditions, will evaporate from 14 to 16 lb. of water from and at 212 deg., 1 lb. of coal will evaporate from 7 to 10 lb., and 1 lb. of natural gas, from 18 to 20 lb.



HEAVY STANDARD MIKADO LOCOMOTIVE

Second Set of Locomotives Built to the Government's Specifications by the American Locomotive Company

THE first of the 157 standard locomotives of the heavy Mikado type to be built for the United States Railroad Administration has been completed at the Brooks works of the American Locomotive Company. The heavy Mikado type is the second of the standard types to be placed in service, locomotives of the light Mikado type having already been built.* With the exception of the light Mikado type, of which 575 have been ordered, the 157 engines of the heavy Mikado type constitute the largest number of any of the other standard types which have been ordered this year.

The design of the heavy Mikados, like that of the light Mikado type, adheres closely to well established practice and is conservative both in the proportions and in the design of details. As far as practicable, interchangeability of details

of the type A superheaters with which the engine is equipped. The boiler is fitted with four 3-in. Cole safety valves and the Chambers throttle.

The firebox is the same width as that of the light Mikado type, but an increase of 6 in. in length provides a great area of 70.8 sq. ft. as compared with 66.7 sq. ft. in the light Mikado boiler. The firebox is fitted with a Security brick arch, and the Shoemaker fire door. The locomotive is fired by a Standard stoker and is fitted with the Franklin grate shaker. The ashpan has two center hoppers, with swinging drop bottoms, both located forward of the trailer axle. The air opening below the mudring is about 5½ in. wide.

A comparison of the boiler capacity with the cylinder demand on the basis of Cole's ratios shows a slightly better than

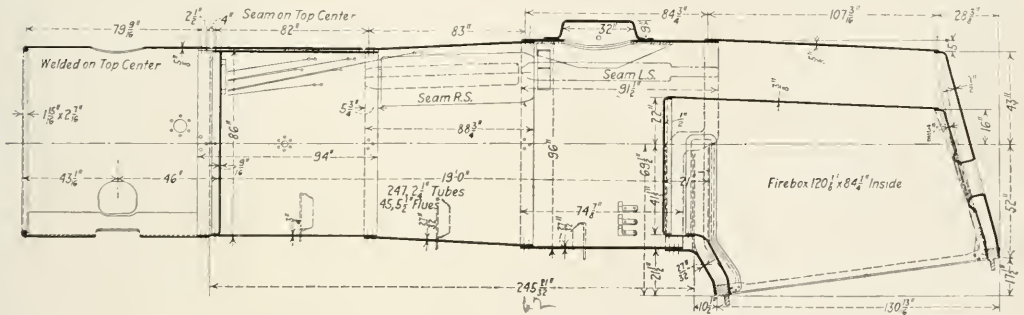

The Boiler for the U. S. Heavy Mikado Type Locomotive.

has been maintained between the various types and a number of those parts on the light Mikado will be found exactly duplicated on the heavy Mikado type.

The boilers are of the conical wagon top type, with a diameter of 86 in. at the front course, increasing to a maximum diameter of 96 in. for the dome course. Comparing this boiler with that of the light Mikado type, it will be seen that the tube sheet is set back 3 in. farther from the center line of the cylinder saddle than in the lighter engine, and that the combustion chamber is 21 in. instead of 24 in. deep, the length of the tubes being 19 ft. in both cases. There are 247 2¼-in. tubes, and forty-five 5½-in. flues for the units

100 per cent boiler, both in heating surface and grate area.

The frame construction compares very closely with that of the light Mikado type locomotive. The main frames are of cast steel, 6 in. wide, and include single integral front rails. Over the pedestals the top rail has a depth of 6.3¼ in., while the lightest section between the pedestals is 5.3¼ in. in depth, these being one-eighth inch thicker than similar sections of the light Mikado frames. Over the binders the lower rails are 4⅞ in. deep, and have a minimum section 4⅞ in. deep. Under the cylinders the frames are of slab section 6 in. wide by 10¼ in. deep. At the front ends where the front deck casting is attached the section is reduced to a depth of 10 in. by 3½ in. in thickness. The wheel spacing of both types is identical, as is also the distance between the center of the cylinder saddle and the first pair of drivers and

* For a description of the United States Railroad Administration standard light Mikado type locomotive see the *Railway Mechanical Engineer*, for August, page 436.

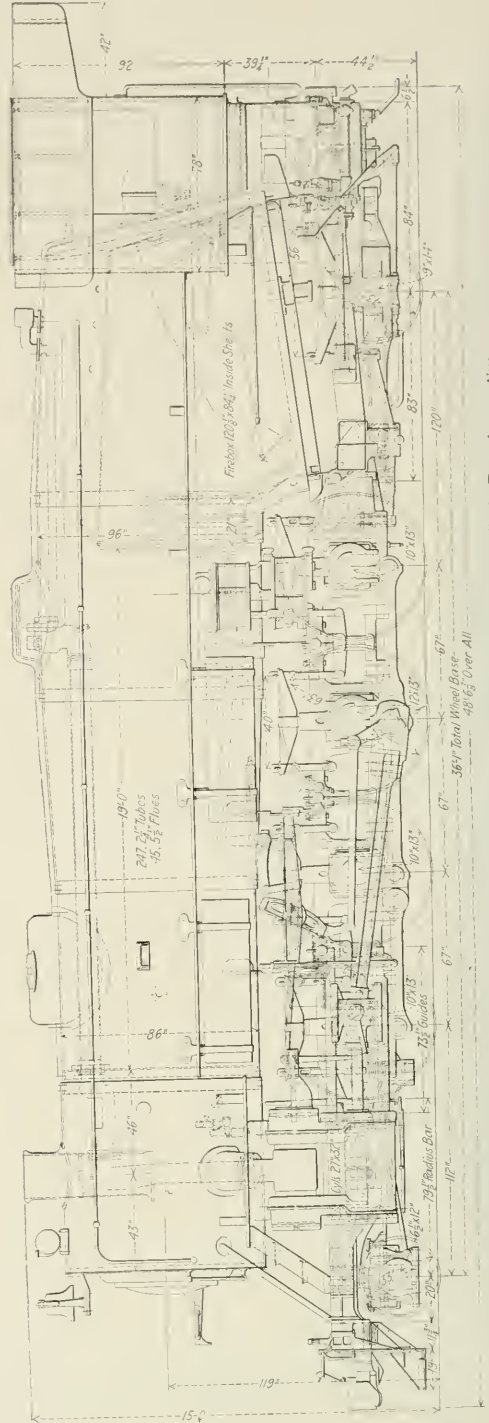
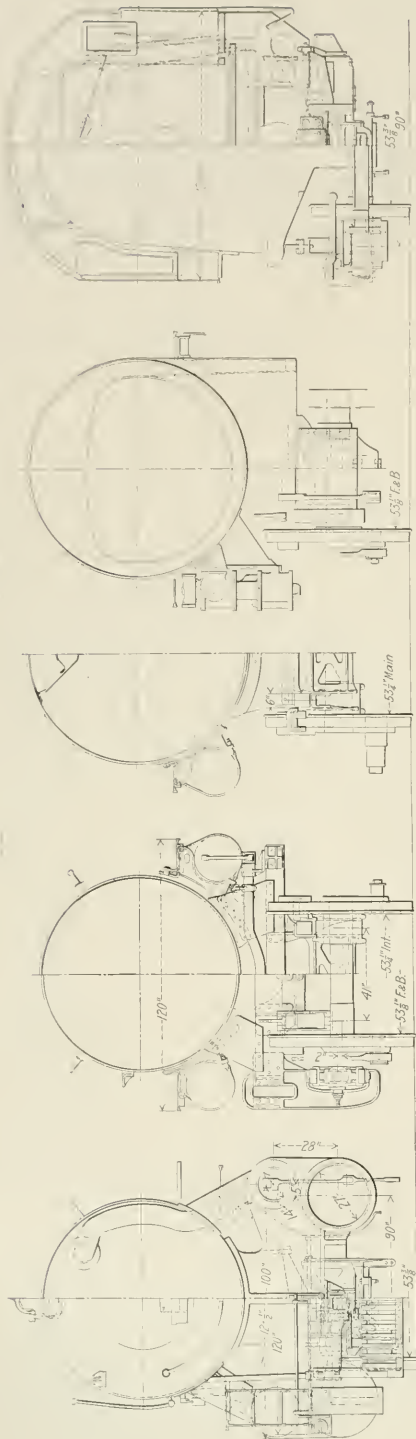

Elevation and Cross Sections of the United States Standard Heavy Mikado Type Locomotive

that between the center lines of the rear drivers and the trailing truck axle. The trailer frames are separate steel castings, each of which is attached to one of the main frames with fourteen 1 1/4-in. bolts, the joint being the same as that

lower frame rails just back of the cylinders, and in which is also included the radius bar pivot for the front engine truck and the driver brake fulcrum. Cast steel driving boxes of straightforward design, fitted with grease cellars, are used throughout. With the exception of those for the main axle, the boxes and axles are all interchangeable with those used on the light Mikado type locomotive, the journals being 10 in. in diameter by 13 in. in length. The main journals are 12 in. in diameter by 13 in. in length, or 1 in. larger in diameter than those of the lighter locomotive. The driving wheels are fitted with brass hub liners.

With the exception of the springs, which are heavier for the heavy Mikado type, the Economy constant resistant engine trucks are interchangeable on the two types. The heavy Mikado type is fitted with Cole-Scoville trailer trucks.

Gun iron bushings are fitted in the cylinders and valve chambers and the packing rings are of the same material. The steel pistons are of single plate sections to which are bolted gun iron wearing shoes. The details of the valve motion follow very closely those of the light Mikado type, the same piston valve and link being used in both cases. The valve chamber heads are also interchangeable. With the exception of the slight difference in the clearance for the front end of the main rod and crosshead pin the crosshead body is identical on both types. The wearing shoes, which are of Hunt-Spiller gun iron, differ in dimensions on the locomotives, but are of the same general style. The valve gear is of the Walschaert type and is fitted with the Lewis power reverse gear. Paxton-Mitchell packing is used for the piston rods and valve stems.

The standard 10,000-gal. tender which is used with the heavy Mikado type is identical with that in use with the light Mikados, and will also be used on several other of the standard types. The design of this tender was briefly outlined in the description of the light Mikado type locomotive. It is carried on four-wheel trucks with 6-in. by 11-in. journals, and among the specialties with which these trucks are fitted it may be of interest to note that the brakebeams are carried on the Creco three-point support and that Woods side bearings are used.

The main rods are of heavy channel section and differ in

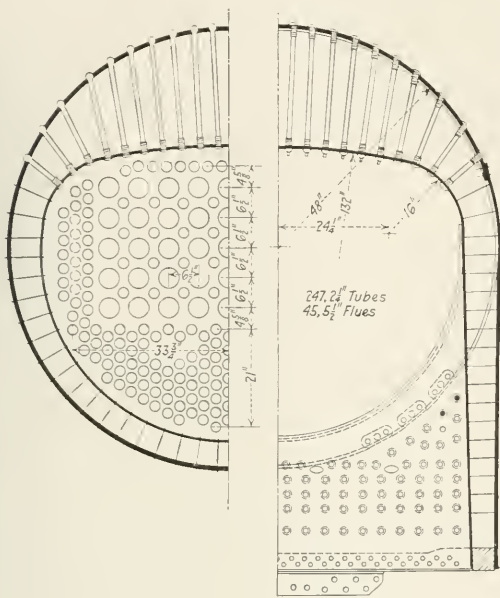

Sections Through the Combustion Chamber and Firebox

employed on the light Mikado type locomotives. At the rear end the trailer frames are bolted to the rear deck casting.

The frame bracing of the two types is practically identical. It consists of vertical crossies bolted to the front legs of the

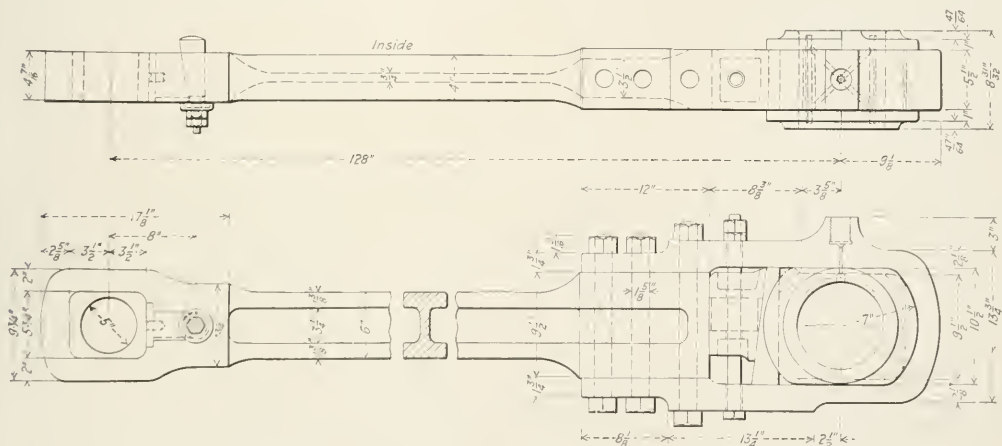

Main Rod for the Government's Standard Heavy Mikado Locomotive

forward driving wheel pedestals and to the rear pedestals of the second and third pairs of drivers; and deck braces applied to the top rails between the first and second and the third and fourth pairs of drivers. The forward vertical brace includes a diagonal extension which is bolted to the

but very few dimensions from those of the standard light Mikado. The stub ends are of the strap type with removable crank pin brasses.

The specialties with which these locomotives are fitted include Everlasting blowoff valves, Ashcroft gages, the Detroit

six-feed lubricator, Hancock No. 11 non-lifting injectors, Barco flexible connections between the engine and tender, the Barco blower fitting, Sargent quick-acting blower valves, and the Radial buffer and Unit safety bar between the engine and tender. The following are the principal data and dimensions of these locomotives:

General Data	
Clearance	4 ft. 8 1/2 in.
Service	Freight
Fuel	Bit. coal
Tractive effort	60,000 lb.

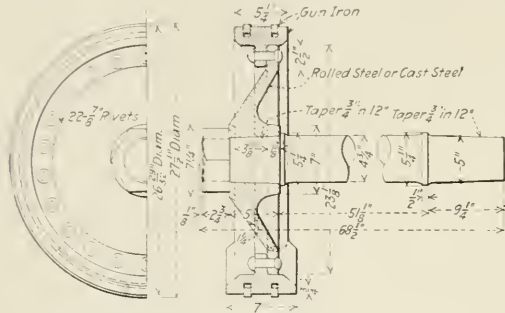

Pistons for the U. S. Standard Heavy Mikado Locomotive.

Weight in working order	325,000 lb.
Weight on drivers	240,000 lb.
Weight on leading truck	28,000 lb.
Weight on trailing truck	37,000 lb.
Weight of engine and tender in working order	497,000 lb.
Wheel base driving	16 ft. 9 in.
Wheel base, total	36 ft. 1 in.
Wheel base, engine and tender	71 ft. 9 1/2 in.

Ratios	
Weight on drivers ÷ tractive effort	4.0
Total weight ÷ tractive effort	5.4
Tractive effort × diam. drivers ÷ equivalent heating surface*	653.2
Equivalent heating surface* ÷ grate area	81.7
Firebox heating surface ÷ equivalent heating surface,* per cent.	13.5

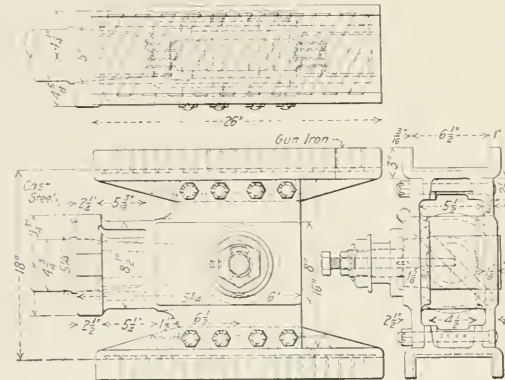

Crosshead for the U. S. Standard Mikado Locomotive.

Weight on drivers ÷ equivalent heating surface*	41.5
Total weight ÷ equivalent heating surface*	56.2
Volume both cylinders ÷ vol. cylinders	21.2 cu. ft.
Equivalent heating surface* ÷ vol. cylinders	272.9
Grate area ÷ vol. cylinders	3.3

Cylinders	
Kind	Simple
Diameter and stroke	27 in. by 32 in.

Valves	
Kind	Piston
Diameter	14 in.
Gravel travel	7 in.
Outside lap	1 1/8 in.
Inside clearance	0 in.
Lead in full gear	16 in.

Wheels	
Driving, diameter over tires	63 in.
Driving journals, main, diameter and length	12 in. by 13 in.
Driving journals, others, diameter and length	10 in. by 13 in.
Engine truck, diameter	24-29 in.
Engine truck, journals	6 1/2 in. by 12 in.
Trailing truck wheels, diameter	43 in.
Trailing truck, journals	9 in. by 14 ft.

Boiler	
Style	Con. wagon top
Working pressure	190 lb. per sq. in.
Outside diameter of first ring	119 in.
Firebox, length and width	120 1/2 in. by 84 in.
Firebox plates, thickness	Sides, back and crown, 3/4 in.; tube, 3/2 in.
Firebox, water space	Sides and back, 5 in.; front, 6 in.
Tubes, number and outside diameter	247-294 in.
Flues, number and outside diameter	45-5 1/2 in.
Tubes and flues, length	19 ft.
Heating surface, tubes and flues	3,978 sq. ft.
Heating surface, firebox, including arch tubes	319 sq. ft.
Heating surface, total	4,297 sq. ft.
Superheater heating surface	993 sq. ft.
Equivalent heating surface*	5,787 sq. ft.
Grate area	70.8 sq. ft.

Tender	
Tank	Water bottom
Frame	Cast steel
Weight	172,000 lb.
Wheels, diameter	33 in.
Journals, diameter and length	6 in. by 11 in.
Water capacity	10,000 gal.
Coal capacity	16 tons

*Equivalent heating surface = total evaporative heating surface + 1.5 times the superheating surface.

INTERESTING NEWS FROM THE RAILROAD ADMINISTRATION

The Mechanical Department of the Division of Operation has announced the following promotions: John F. Tatum has been appointed general supervisor of car repairs; F. P. Pfahler, who has hitherto borne the title of mechanical engineer, has been made chief mechanical engineer; John McManamy and George N. De Guire, assistant supervisors of equipment, have been made, respectively, general supervisor of equipment, west, and general supervisor of equipment, east. The appointments were all effective August 3 and all the appointees will have headquarters at Washington.

LOCOMOTIVE SITUATION

The requirements of our armies in France, including the order placed during the month with the Baldwin Locomotive Works for 510 additional 80-ton Consolidation locomotives, will delay somewhat the progress in delivery of the Railroad Administration's standard locomotives for use on this side of the water, of which 1,430 have been ordered. At the same time the Railroad Administration is preparing to take out of service the 135 similar locomotives which were built for our armies in France and turned over to eastern roads last winter. These locomotives will be sent to the Baldwin Locomotive Works, which built them, to be put into shape ready for transportation overseas at the rate of five a week until the entire lot is turned over.

To overcome the insufficient building capacity the War Industries Board, in conference with the locomotive builders and officers of the Railroad Administration, have made plans whereby the output of the locomotive shops will be increased to 6,000 engines a year. The output will be divided about half to Pershing and the Allies and half to the Railroad Administration.

It is reported that the mechanical department of the Railroad Administration expects to compensate for the delay in the construction of the standard locomotives and the withdrawal of the army locomotives from service here by the special efforts which it has been making since last winter to rush the repair of domestic locomotives. A large number of these locomotives are already in shape and are in white lead, ready for next winter. Several of the standard locomotives have already been delivered.

STANDARD CARS

Progress on the standard cars is considered favorable. The first completed standard cars are expected to be delivered

the first week in September and to continue regularly after that. It is not expected that the order for cars recently placed for the American forces overseas will hinder the production of the cars for the Railroad Administration.

The Committee on Standards for Locomotives and Cars, of which Frank McManamy is chairman, held a meeting recently to go over specifications for standard baggage and express cars and coaches. It also examined plans covering these types of cars recently prepared by the builders and presented through the committee of the builders, of which J. M. Hansen of the Standard Steel Car Company is chairman. The specifications and drawings should be ready in a short time, after which negotiations will be begun for their purchase. It is not unlikely that two designs of coaches may be considered, one for through trains and one for suburban service, although the last will probably be a later development.

DRAFT CLASSIFICATION OF SKILLED RAILWAY MEN

Provost Marshal General Crowder has sent a message to all draft officials requesting reconsideration of the classification of railway men in Class I. Reconsideration is especially asked in the case of applicants employed as machinists, blacksmiths, boilermakers, tin and copper smiths, pipefitters and helpers and apprentices of all of the foregoing, hostlers, enginehouse men, train dispatchers and directors, telegraphers, telephoners, and block operators, locomotive firemen and helpers, conductors, yard foremen, brakemen, track foremen, telegraph clerks, yardmasters and assistants, locomotive engineers and motormen.

Application should be made by the individual and filed with the district board or the local board for transmission to the district board, asking reconsideration of classification on the ground that the applicant is engaged in a necessary industrial enterprise as a skilled laborer especially fitted for the work in which he is engaged, or as a highly specialized technical or mechanical expert, as the case may be. In case an individual does not wish to make application or it is impracticable for him to do so, application may be made by the federal manager, general manager or other representatives of the Railroad Administration. Applications should be supported by affidavits made by representatives of the Railroad Administration preferably not below the rank of division superintendent.

MISCELLANEOUS ITEMS

Headlights for Switching Engines.—At the meeting of the Committee on Standards for Locomotives and Cars which was held in Washington recently the question of suitable headlights for switching locomotives was discussed and it was unanimously agreed by members present that electric headlights are more efficient and economical than any other type of headlight. The regional directors have, therefore, been advised to express to their federal managers the desire that when necessary to make changes in headlights on switching engines to meet the requirements of the law or on account of renewals they be equipped with a headlight of the incandescent type with a turbo-generator and the bulb of suitable wattage.

Mechanical Stokers.—The eastern regional director is asking for the following information from each road; number of locomotives of 45,000 lb. tractive power or more; how many are now equipped with mechanical stokers; type of stoker, what is policy or recommendation regarding the application of stokers to the balance of the locomotives of above mentioned capacity.

Conserving Materials.—The eastern regional director directs attention to the necessity of reclaiming as far as practicable all iron and steel parts and suggests that the use of oxy-acetylene and electric welding outfits should be increased.

Transfer of Bad Order Cars.—The southern regional

director has emphasized the necessity for sending in to the regional director detailed information concerning cars that are being sent from one road to another for repairs, in order to relieve the bad situation on various roads.

FUEL CONSERVATION SECTION ACTIVITIES

The Fuel Conservation Section of the Division of Operation has completed its organization and now includes Eugene McAuliffe, as manager, and Major E. C. Schmidt, assistant to the manager; Robert Collett, assistant manager and supervisor for the eastern region; Howard C. Woodbridge, supervisor, Allegheny Region; Harry Clewer, supervisor, Pocahontas Region; Bernard J. Feeney, supervisor, Southern Region; Frank P. Roesch, supervisor, Northwestern Region; Leslie R. Pyle, supervisor, Central Western Region, and J. W. Hardy, supervisor, Southwestern Region. The supervisors will give special attention to the conservation of fuel used on locomotives, in shops, at terminals, at water stations, and for all miscellaneous purposes. They will also give attention to the preparation of fuel received and to its quality; and they will make investigations and recommendations with respect to its transportation to and its handling at fuel stations.

CIRCULARS NOS. 8, 9, AND 10

Fuel Conservation Circular No. 8, addressed to motive power officers concerned with locomotive maintenance, draws attention to certain sources of fuel loss which can be remedied by proper locomotive maintenance, and reads as follows:

The inspection of locomotive front-ends on certain roads shows that there is a marked variation in the size of exhaust nozzles. In many instances exhaust nozzles have been decreased in size because of the presence of air leaks in the front-end, which of course partially destroys the vacuum and necessitates excess draft. Such leaks can be readily located when the engines are under steam or when they are located near an outside steam supply, by using the blower to create a draft and holding a lighted torch to all seams and joints.

In superheater locomotives with outside steam pipes, leaks are frequently found under the covering of the steam pipe where it goes through the sheet. When so located, the leak does not show a burnt spot.

Any front-end leakage obviously increases the amount of steam which must be moved by the exhaust jet, and consequently necessitates a reduction in the size in the nozzle tip. This of course increases the cylinder back pressure and entails fuel losses; and in addition frequently leads to partial engine failures and to an increased cost of front-end maintenance.

Every motive power official and employee who is responsible for the maintenance of locomotives should see to it that front-ends on locomotives are tested for air leaks at frequent intervals.

Circulars Nos. 9 and 10, addressed to the men in engine service, are practically the same, and read as follows:

Our government today is spending not millions, but billions of dollars for labor and supplies, for arms and ammunition, and for ships to move men and material.

We are in this war to win. We shall have to pay for winning, as we always pay for anything worth while. This is not the President's job; it is not Secretary Baker's job, nor Secretary Daniels' job, nor Director General McAdoo's job. It is our job.

With this point settled and everybody agreed, what remains for you and me to do? The answer is to work and to save. Why? Because nothing but labor and material will do the business. Money will not do it. It cannot be worn nor used for food; like the steam rage on the boiler, it is something to show pressure—but the steam rage never pulled a car. Human labor, human intelligence, and what they create are the vital things. Food and clothing, rifles and machine guns, shells and ships, all spring from these.

We shall win the war by the material we produce and by the way we use it. We must get the most out of it, whether it be fuel, munitions or food. In the case of railroad fuel, we must make every ton move its maximum of men and material. You all know the ways in which this can be accomplished. This section is getting out a little handbook, containing suggestions of how to save railroad fuel. It will reach you within a few days. There is nothing newfangled about it. You have all heard for years the suggestions it contains; but if every man would observe these suggestions in his daily work, we should save an enormous amount of coal.

We urge you to make a showing, but you must have the opportunity. Here it is—and as fine a chance as any man could wish for. This is the railroad bill for bituminous coal before and since the war.

Year	Period	Tons	Cost per ton	Value at mines
1915	Before the war	122,000,000	\$1.13	\$137,860,000
1917	First year of the war	155,000,000	2.13	330,150,000
1918	Second year of the war	166,000,000	2.50	415,000,000

These are the costs of the coal at the mines. During 1918 it will cost a dollar more per ton for company haul and handling; and for the 48,000,000 barrels of fuel oil which the railroads will use this year, they will pay \$60,000,000. *This will make the railroad fuel bill for this year \$650,000,000, excluding the cost of anthracite.*

Here are reasonable estimates of the savings which will result from even a moderate amount of extra effort and attention:

1 per cent saving represents.....	\$6,500,000
2 per cent saving represents.....	13,000,000
4 per cent saving represents.....	26,000,000

We present these facts to you in terms of dollars because the size of the job is most readily understood in such terms. *Remember, however, that it is not dollars we are interested in, but coal.* Coal sells for a fixed price per ton, but nobody can say today how much it is really worth. Coal enough in the next twelve months may well make the difference between winning or losing the war.

A coal shortage looms up ahead. It is estimated at about 75,000,000 tons. The shortage last year was 60,000,000 tons. There are only three ways in which to make this good:

- First—By providing cleaner coal.
- Second—By shutting off the so-called non-essential industries.
- Third—By conserving by every possible means the coal which we must use.

The coal miners are going to do their share by giving us cleaner coal. They have been appealed to, and they are responding.

Scores of so-called non-essential industries have already curtailed their output; to go further in this direction will mean unemployment and disaster for your friends and neighbors. There is not much more to be had along this route.

The shortage must be made good chiefly by *care in the use of food.* The railroads use nearly one-third of all fuel produced in the country, and a large share of the responsibility consequently rests on us. The Railroad Administration has given and will continue to give special attention to the improvement of the condition of power. The rest is up to us.

The miner will save his 2 per cent by giving us cleaner coal. The improved condition of power will contribute as much more. We railroad men who use the coal should contribute our 2 per cent. We may well do much more. Let us all pull together for a saving of 10,000,000 or perhaps 20,000,000 tons. We can make it if everyone puts his shoulder to the wheel.

If we win in this attempt, we shall have contributed to the successful outcome of the war; we shall have safeguarded ourselves, and our friends and neighbors from discomfort and unemployment; and we shall have added to our own skill and increased our own satisfaction and self-respect. *We shall have lined up solidly behind the first line "over there."*

FUEL LOSSES CAUSED BY HOSTLERS

A communication relative to the fuel losses caused by hostlers not handling to the best advantage the movements of engines to and from the passenger stations was sent to the regional directors. In this letter the manager of the fuel conservation section said:

"My attention has been directed to the fact that a great many terminal locomotives are delivered to the crews at the passenger stations by hostlers: in a similar manner the crew on arrival abandon the engines in the passenger stations, hostlers moving same to roundhouse.

"In many instances the engines are fired up so as to conform to the schedule established by the hostler and his helper, enabling him perhaps to move all passenger engines during a certain pre-determined period. In a similar manner engines are allowed to stand at passenger stations, in some instances for several hours, waiting for the hostler to remove same to the roundhouse, this situation representing a very material fuel loss.

"Will you ask the several federal managers to make a canvass of this situation, attempting to organize the stand-by time of passenger locomotives moved by hostlers from and to passenger stations to the end that such be reduced as much as possible."

FUEL ECONOMY DISCUSSED AT THE PITTSBURGH RAILWAY CLUB.

H. C. Woodbridge, supervisor for the Allegheny Region, read a paper before the Pittsburgh Railway Club, in which he mentioned the various methods by which all railroad men can assist in saving fuel. In a message to master mechanics, traveling engineers and roundhouse men the following points were strongly emphasized:

Find out how much coal you are using in banking and building fires and how much you can reduce this amount. Try banking the fires on the front of the grates only, using wet coal.

Avoid as much as possible the waste of coal which falls through grates when preparations are being made to fire up.

Stop unnecessary blower line losses and other leaks.

Cover steam pipes in roundhouses and shops and on your locomotives with suitable lagging.

Stop leaks in your stationary boiler settings and arches. Use dampers and have the flue gases analyzed.

Stop air leaks into smokeboxes.

Provide sufficient air opening in ashpan—at least 14 per cent of grate area.

Don't overload tenders, and keep the unused coal shoveled ahead. It spoils on the back of tank, injures the sheets and is just that much useless load to drag around.

Correct improper steam distribution. A lame engine in this country is the Kaiser's delight.

Report poor coal, giving enough information so that the mine at which it was loaded can be located and properly dealt with.

Determine the proper size and character of nozzle tip for various classes of engines, and keep a record of nozzle sizes: make frequent checks to correct errors in draft appliances. Don't monkey with nozzle tips; correct defects which cause steam failures.

Use scrap wood for fuel when practicable.

Record condition of fires in incoming engines and advise the road foreman or instructors when improper firing is evident so that the inexperienced man will be instructed as soon as possible.

If consistent don't clean fires on incoming engines which will go out soon. Clean these fires when engine is taken out. The ashes will help keep the pops down and at the same time protect the flues while engine stands at your terminal.

On the Chicago & North Western a test made last winter when the temperature was below freezing showed that an engine having its stack covered after the fire had been knocked out and the grates covered with green coal would stand from 8 p. m. Saturday until 2 a. m. Monday morning and have 20 lb. of steam on boiler at 2 a. m. Monday morning.

Repair steam heat regulators and piping before cold weather sets in.

Keep boilers clean of soot clinkers in flues and mud and scale inside. Mr. Foque, of the Soo Line, stated that in a bad water district of that road \$163,000 in fuel alone was saved in one year by properly cleaning locomotive boilers.

Do the work for which you are best fitted and delegate office work and the investigation of non-essentials, post-mortems, etc., to others.

Get a counter and compare the number of scoops of coal used by various crews in similar service between given points and let the men know the results.

Instruct new men.

Have your instructors spend some time with fire cleaners and builders, as well as with the roadmen.

Supervise systematically the preparation of fires before starting, as well as fires in incoming engines.

You know the thousand things to do. Hit the most important things first and hardest. Do your full duty more thoroughly than ever before.

SUBSTITUTES FOR GREASE.—Owing to the scarcity of grease in Germany, engineers in that country are paying much attention to other forms of lubricating material. Der Papier-Fabricant says that from 40 to 60 per cent of tallow mixed with mineral oil is effective and economical, and that high-grade graphite may be substituted for the tallow. Artificial graphite is manufactured in Germany both by intensive chemical treatment and by subjecting carbonaceous material to the heat of an electric arc in a space from which air has been excluded.

THE TIME LOST IN SLOWDOWNS

A Method of the Application of the Principles of Acceleration Illustrated by a Typical Example

BY WALTER V. TURNER, Eng. D.,
Manager of Engineering, Westinghouse Air Brake Company

WITH a train in steam road service, the maximum possible rate of change of velocity is considerably greater during the period of deceleration than during the period of acceleration. That it should be so, is quite evident from the fact that the accelerating force is secured from the engine alone and thus is limited by the weight on the drivers times the coefficient of adhesion between the driver wheels and the rail; while the decelerating force is obtained on the engine and every car in the train, and consequently is

and front truck .45; of light weight of tender 1.1 with 50 lb. cylinder pressure; of cars .90 with 80 lb. cylinder pressure.

The first step will be to find the velocity-distance and time-distance relations when the train is accelerated at the maximum rate possible under the given conditions. To do this, the tractive effort available for acceleration must be found. Since this factor depends upon the train resistance and the tractive effort actually developed between the drivers and the rail, these latter items must first be computed.

The limit of the tractive effort developed at the rail is, the weight on the drivers multiplied by the coefficient of adhesion between the driver wheels and the rails. Since this value is not constant, due to the variation in the condition of the rail, the locomotive is designed to develop a tractive effort within a safe margin of the minimum probable limit. Otherwise, the driver wheels would slip, accompanied by all the attendant difficulties.

While the above enumerated factors determine how much tractive effort may be obtained, how much is actually secured depends upon the size of the boiler, dimensions of the fire-

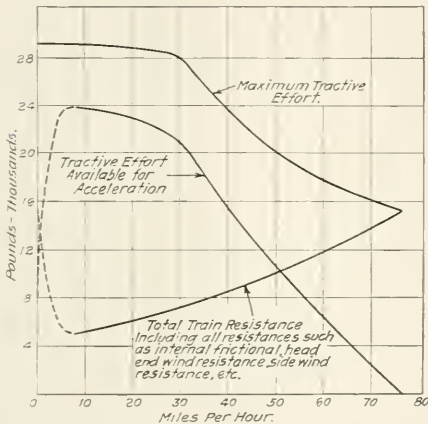

Fig. 1—Train Resistance and Tractive Effort Curves

only limited by the weight of the whole train times the coefficient of adhesion between the wheels and the rail.

The object of this paper is to compare acceleration with deceleration in steam road service, to compute the time lost by a slowdown, and to show how these determinations may be made theoretically. For clarity, the following specific case will be used: a Pacific type locomotive with 10 Pullman cars, decelerating from 70 to 30 miles per hour, under braking conditions mentioned later, then running at 30 miles per hour for a distance of 13,825 ft. and finally accelerating at the maximum rate possible with the given train and locomotive from 30 to 70 miles per hour.

The data are the following—one Pacific type locomotive, weight on drivers 175,000 lb., weight on front truck 50,000 lb., weight on back truck 50,000 lb., weight of tender, loaded, 155,200 lb., and weight of tender, empty, 66,700 lb.; drivers 79 in. in diameter, cylinders 22 in. in diameter by 28 in. stroke; 200 lb. steam pressure; evaporative heating surface 5791.5 sq. ft., superheating surface 723.8 sq. ft. The rate of evaporation is assumed to be 10 lb. of water per hour per square foot of equivalent heating surface. The total weight of the cars is 1,567,000 lb., and all are equipped with the "P" brake equipment. A brake pipe pressure of 110 lb. is carried and a total brake pipe reduction of 12 lb. is used to decelerate the train from 70 to 30 miles per hour. The braking rates are as follows: Of drivers .60; of trailers

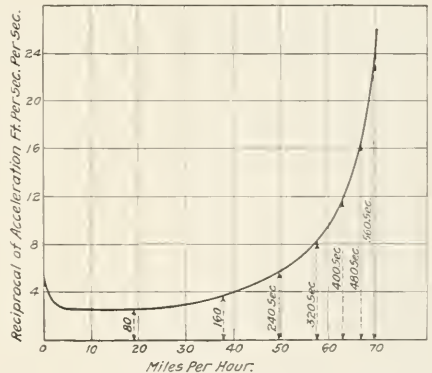

Fig. 2—Time Required to Accelerate to Various Speeds

box, size of steam chests, etc. The tractive effort obtainable depends upon the following quantities:

- TF = The total tractive effort developed by the cylinders in pounds.
- H = The entire heating surface of the boiler in sq. ft. (For superheated locomotives multiply the superheater surface by 1.5, and add it to the other heating surfaces.)
- Pc = The initial (gauge) cylinder pressure in lb. per sq. in. (taken as 10 lb. lower than boiler pressure.)
- Pb = Boiler pressure, pounds per sq. in. (gauge.)
- E = The pounds of water actually evaporated per hour per sq. ft. of equivalent heating surface.
- W = The weight of one cubic foot of steam at the initial cylinder pressure and temperature in pounds.
- S = The speed of the train in miles per hour.
- $\frac{d^2}{dt^2}$
- $\frac{d}{dt}$
- d = Internal diameter of steam cylinder in inches.
- l = Stroke of the piston in inches.
- D = The diameter of the driver wheels in inches.

If the transmission of steam from the boiler to the steam chest, etc., were accomplished without any losses, then

$$\frac{TF}{H} = \frac{Pc}{Pb} \frac{E}{W} \frac{d^2}{dt^2}$$

Inasmuch as the transmission is not perfect, but only about 85 per cent so,

$$TF = \frac{.85 Pvd^2}{D}$$

This equation holds true, with slight variation, as long as the space displaced by the pistons in a unit time does not exceed the volume of steam, at full boiler pressure, generated in the same time; and, of course, with the valve gear adjusted to permit steam to enter the cylinders at the maximum cut-off. On this basis, the tractive effort developed at slow speeds is equal to:

$$\frac{.85 Pvd^2}{D} = \frac{.85 \times 200 \times 22 \times 28}{79} = 29,150 \text{ lb.}$$

Next, the train speed at which steam is supplied to the cylinders at as fast a rate as it can be generated, must be determined. Whence:

W = The weight of one cubic foot of steam at the initial cylinder pressure and temperature, in lb. (from Marks' and Davis' Steam Tables for 190 lb. gage pressure and 200 deg. F. superheat) = $\frac{1}{2.97} = .337$

$$\frac{HE}{W} = \frac{.3791 + 7.24 \times 1.5 \times 10}{.337} = 145,000 \text{ cu. ft. of steam, at 190 lb. gage pressure and 200 deg. F. superheat, generated per hour.}$$

$$\frac{4\pi d^2}{4 \times 17.28} = \frac{4 \times 3.1416 \times 22^2 \times 28}{4 \times 17.28} = 24.6 \text{ cu. ft. of space displaced by the locomotive pistons per revolution of the driver wheels.}$$

Hence:

$$\frac{145,000}{24.6} = 5900 \text{ revolutions of the drivers per hour.}$$

Therefore:

$$\pi D \times \text{rev. drivers per hr.} = \frac{79 \times 3.1416 \times 5900}{12 \times 5280} = \frac{79 \times 3.1416 \times 5900}{12 \times 5280} = 23.1 \text{ mi. per hour}$$

Beyond this speed steam cannot be generated at a sufficiently fast rate to fill the space displaced by the pistons, at

In applying it to the case under consideration:

$$P_e = 200 - 10 = 190$$

$$C = \frac{22^2 \times 28}{79} = 171.2$$

$$H = 3791 + 1.5 \times 7.24 = 4877$$

$$E = 10$$

Therefore:

$$TF = \frac{2 \times 190 \times 171.2}{110 \times .337 \times 171.2 \times S} = \frac{65,200}{3 \times 10 \times 4877} + 1 = .04358 + 1$$

Consequently:

S	T. F.
30	28,200
40	23,800
50	20,500
60	18,100
70	16,160

The values given above are plotted in Fig. 1 as maximum tractive effort. It should be understood that this is the max-

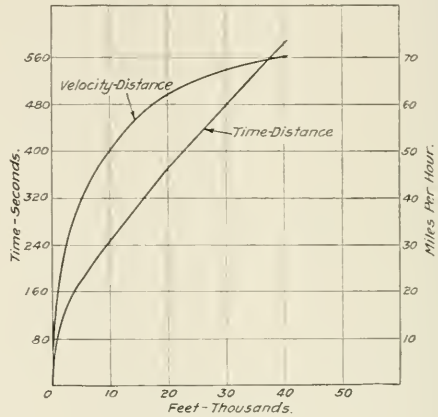

Fig. 4—Time-Distance and Velocity-Distance Curves for Acceleration

imum tractive effort possible to obtain from the locomotive under the given conditions. It would, of course, be difficult for the engineer to manipulate his valve gear so precisely as to reproduce exactly these curves; but nevertheless, since the determination of the maximum possible conditions is the intention, this consideration of operation will be neglected.

The total tractive effort developed, however, is not entirely available for acceleration, for part of it is required to overcome the train resistance. Train resistance consists of journal friction, rolling friction, head-end, rear-end and side wind resistance, grade and curve resistance, etc. The formula for train resistance, with the following notation, is:

R = Total train resistance in lb.
 N = Number of cars (locomotive with its tender is considered the equivalent of three cars).
 T = Total weight of train in tons.
 V = Velocity of train in miles per hour.
 A = Curvature in degrees.
 G = Grade in per cent.
 H = Number of pairs of drivers.
 Z = Weight on drivers in tons.

$$R = 100 N + (1.5 - K + 20 G) T + .01 V(V + 16) \sqrt{TN} + [22 + .15(B-1) V] Z + .1 V^2$$

In this specific case:

N	= 10 - 3 = 13
K	= 0
G	= 0
T	= 173,000 lb. Weight on drivers.
	50,000 lb. Weight on front locomotive truck.
	50,000 lb. Weight on back locomotive truck.
	66,700 lb. Weight of tender (empty).
	33,250 lb. Weight of half load in tender.
	372,950 lb. Weight of engine and tender.
	1,567,000 lb. Weight of cars.
	1,939,950 lb. Total weight of train.

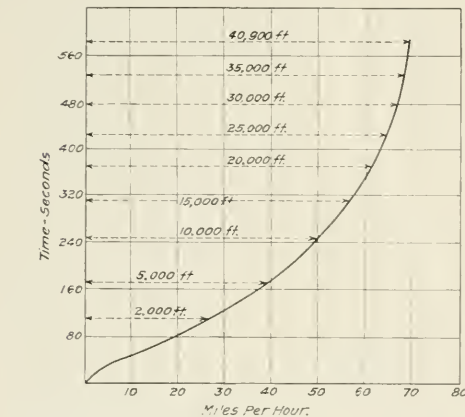

Fig. 3—Time and Distance Required to Reach a Given Speed

substantially full boiler pressure. For this reason, the cut-off must be decreased and hence the maximum obtainable tractive effort will of necessity be decreased with an increase in speed.

The values derived from the following formula* take care of this condition:

$$TF = \frac{2P_e C}{110 CSW} = \frac{2P_e C}{3EH} + 1$$

*This is known as the Kiesel tractive effort formula. For its derivation see the *Railway Mechanical Engineer* for December, 1916, page 627.

$$\begin{aligned}
 & \frac{1,939,950 \text{ lb.}}{2000} = 970 \text{ tons.} \\
 B &= \sqrt{13} = \sqrt{970 \times 13} = 112.3 \\
 & \frac{173,000}{20 \cdot 0} = 86.5
 \end{aligned}$$

Whence:

$$R = 100 \times 13 + (1.5 \times 975) + .01 \sqrt{V(V + 16)} 112.3 + \frac{.15(3 - 1)V}{V^2} 86.5 + .1 V^2$$

Therefore:

$$R = 4663 + 44V + 1.23 V^2$$

The total train resistance for various speeds is given below:

V	R (Total)
10	5,226
20	6,035
30	7,090
40	8,393
50	9,943
60	11,733
70	13,773

These values of resistance are plotted under the caption "Total Train Resistance" in Fig. 1. This formula, however, does not provide for the total train resistance between 0 and 5 miles per hour. When the train is set in motion, all its frictional resistance, being functions of the static coefficient of friction, are of greater magnitude than at somewhat higher speeds. As the velocity of the train increases, the coefficient of friction decreases so that from 5 to 10 miles per hour the total train resistance attains its minimum value, which is $\frac{1}{3}$ (approximately) its magnitude at 0 miles per hour. From this fact, the train resistance between 0 and 5

realize this objective. The first step is to find the relation between velocity and time. Now, the time to change from one velocity to another equals:

$$\int_{V_1}^{V_2} \frac{1}{A} \frac{V}{V^2} dV$$

From this equation, it can be seen that if velocity is plotted as one scale and reciprocal of acceleration as the other, the area included between the curve and the velocity axis is proportional to the time required to change from one velocity to another. For the purpose of making such a graph, the reciprocal of acceleration for various velocities must be found. The reciprocal of acceleration from Newton's second law of motion, where:

- F = Tractive effort available for acceleration.
- T = Total weight of train in pounds.
- g = Acceleration of gravity, 32.16 ft. per second per second.
- A = Acceleration of the train in ft. per second per second.

is given by the equation—

$$F = \frac{T}{g} A$$

Hence, the reciprocal of acceleration,

$$\frac{1}{A} = \frac{T}{Fg}$$

Now:

$$\frac{T}{g} = \frac{1,939,950}{32.16} = 60,500$$

(The rotative inertia of the wheels is so small that it has little effect and is neglected in this calculation.)

In the following table various values of $\frac{1}{A}$ are given.

using the values of F for the various velocities as shown in Fig. 1:

V	F = T.F - R	$\frac{T}{g}$	$\frac{1}{A}$
0	0.000	60,500	6.74
2	19,270	60,500	3.15
5	23,000	60,500	2.65
10	33,374	60,500	1.82
20	46,865	60,500	1.29
30	61,118	60,500	.98
40	75,967	60,500	.79
50	90,357	60,500	.67
60	105,277	60,500	.57
70	120,727	60,500	.50

The reciprocal of acceleration thus found, is plotted against the velocity of the train in Fig. 2. Consequently, as explained above, the area between this curve and the miles per hour axis is proportional to the time to change from one velocity to the other. Thus, 80 sec. are required to accelerate the train, at its maximum possible rate under the given conditions, from rest to 19 m. p. h.; 160 sec. from rest to 38 m. p. h.; 240 sec. from rest to 49 1/2 m. p. h., etc.

These determinations in Fig. 2 now make it possible to plot speed against time as shown in Fig. 3. The advantage of such a graph is seen from the relation that

$$\int_{S_2}^{S_1} ds = \int_{T_1}^{T_2} V dt$$

whereby the area between the curve and the time base is proportional to the distance traversed. Thus, to cover 2,000 ft. from rest, with the train accelerating at its maximum possible rate, requires 110 sec. at which time a velocity of 27 1/2 m. p. h. is attained; to cover 5,000 ft. 170 sec. are required, at which time a speed of 39 1/2 m. p. h. is developed, etc.

From these values, the time-distance and velocity-distance curve may be plotted as in Fig. 4. This figure thus gives the relations desired in regard to the acceleration of the train and will be combined in a later curve with corresponding values for the deceleration of the train.

Now, the next procedure is to adopt a process somewhat

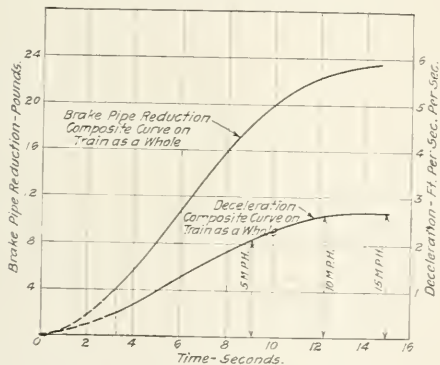

Fig. 5—Composite Curves of Brake Pipe Reduction and Deceleration

miles per hour is plotted as shown by the dotted line in Fig. 1. With a further increment in speed, (from 5 m. p. h.) the total resistance increases, because the rolling friction, machinery friction of the locomotive and the wind resistance are increasing functions of the speed, as is apparent from the above calculations and the curve in Fig. 1.

The previous determinations now make it possible to calculate the tractive effort available for acceleration. These values are represented by the middle curve in Fig. 1, which is obtained by subtracting the ordinates of total resistance from the ordinates of maximum obtainable tractive effort. As is apparent from the character of the other two curves on this figure, this value is comparatively high between 5 and 20 odd miles per hour and then continues to drop until it is 0 at 75 miles per hour. In other words, at 75 miles per hour, the maximum obtainable tractive effort equals the total train resistance, so that on a level tangent, the highest obtainable speed for this given train and engine is 75 miles per hour.

Inasmuch as the ultimate purposes of this calculation is to ascertain the time-distance and velocity-distance relations during acceleration, two intermediate steps are required to

similar to the foregoing for determining the retarding action of the brakes on the train. In all brake equipments in which the brake action is produced by purely pneumatic means, air is vented from the end of the brake pipe on the engine through the brake valve. This reduction in brake pipe pressure naturally affects the valve on the head car first and

Braking ratio per lb. cylinder pressure =	$\frac{.60}{50}$	= .012 for the drivers.
Braking ratio per lb. cylinder pressure =	$\frac{.45}{50}$	= .009 for the front truck.
Braking ratio per lb. cylinder pressure =	$\frac{.45}{50}$	= .009 for the back truck.
Braking ratio per lb. cylinder pressure =	$\frac{.50}{7.34}$	= .0147 for the half-loaded tender.

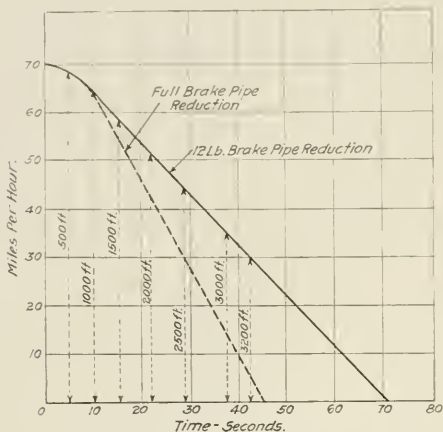

Fig. 6—Velocity-Time Curve for Deceleration

on each car in succeeding order thereafter. Hence, the brakes apply serially and until the brake pipe reduction is completed the brake pipe pressure is different on every car. For purposes of calculation, however, it is advantageous to consider the average brake pipe reduction throughout the train for each given period of time. These values, when

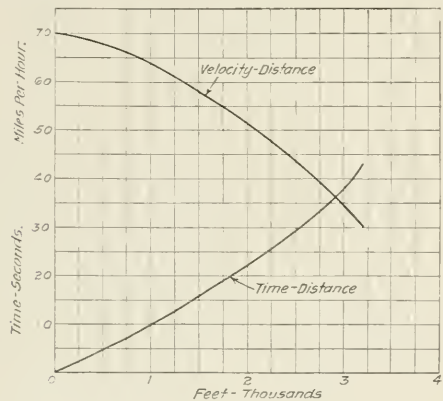

Fig. 7—Time-Distance and Velocity-Distance Curves for Deceleration

plotted, are called a "composite" curve and are shown on Fig. 5. The composite curve has been determined from test values.

For each brake pipe reduction, a corresponding brake cylinder pressure is developed; and this brake cylinder pressure, in turn produces a given brake shoe pressure from which a particular deceleration is realized. From the composite brake pipe reduction curve on Fig. 5, the composite curve for the deceleration of the train as a whole is determined as follows:

Since a 1-lb. brake pipe reduction is approximately equal to a 2.5-lb. brake cylinder pressure, with the E. T. equipment:

Braking ratio per lb. brake pipe reduction =	$.012 \times 2.5$	= .03 for the drivers.
Braking ratio per lb. brake pipe reduction =	$.009 \times 2.5$	= .0225 for the front truck.
Braking ratio per lb. brake pipe reduction =	$.009 \times 2.5$	= .0225 for the back truck.
Braking ratio per lb. brake pipe reduction =	$.0147 \times 2.5$	= .0368 for the half-loaded tender.
Braking ratio per lb. brake pipe reduction =	$\frac{.9}{24}$	= .0375 for the cars.
<hr/>		
$173,000 \times .03 + 51,000 \times .0225 + 50,000 \times .0225 + 99,950 \times .0368 +$	<hr/>	
	1,939,950	
$1,567,000 \times .0375 =$.0360 brake ratio per lb. brake pipe reduction.	
	<hr/>	
	1,939,950	

Where:

- d' = the deceleration of the train in ft. per second per second.
- D' = the braking ratio, i. e., the total pressure that the brake shoes would exert against the wheels of the train, if the brake rigging were 100 per cent efficient, divided by the weight of the train.
- e' = the efficiency of the brake rigging.
- f' = the mean coefficient of friction between the shoe and wheel.
- F_g = the acceleration of gravity in feet per second per second.
- F = force developed by the brake shoes in decelerating the train.
- T = weight of the train in pounds.

Then—

$$F' = \frac{T}{g} \times d'$$

also—

$$F' = D' T e' f'$$

therefore—

$$\frac{T}{g} d' = D' T e' f'$$

or

$$d' = D' e' f' g$$

Since the braking ratio per pound of brake pipe reduction = .0360, $e' f' = 1$ and $g = 32.16$, the deceleration of the train per pound brake pipe reduction equals $.0360 \times 32.16 \times 1 = .115$ ft. per second per second.

By multiplying this factor with the value of the composite brake pipe reduction for each given time, a composite deceleration curve may be produced as shown in Fig. 5.

Since, as in the case of acceleration, the object of this procedure is to determine the time required to make various changes in the velocity; this relation can be found by the area between the deceleration curve on Fig. 5 and the time axis, because

$$\int_{V_1}^{V_2} \delta V = \int_{T_1}^{T_2} A \delta T$$

Thus, it is found that the train speed reduces 5 m. p. h. in about 9.1 sec.; 10 m. p. h. in 12.2 sec., etc.

From the values obtained in this figure, time is plotted against velocity as indicated by the dotted line in Fig. 6. The dotted line is for a full brake pipe reduction, i. e., that reduction in brake pipe pressure which will produce the maximum possible brake shoe pressure for a service brake application. The bend in the upper portion is due to the variation in deceleration while the brakes are in the process of applying. After a full brake application is developed, the deceleration becomes substantially constant and the curve then closely follows a straight line.

In the instance under consideration, however, a 12 lb. brake pipe reduction was made. Consequently, a tangent which represents this deceleration must be drawn to the dotted line. Hence, after the brake application is initiated,

the deceleration increases until the 12-lb. value is reached, whereupon, the braking forces remain substantially constant until the brake is released.

Since the relation—

$$\int_{S_1}^{S_2} \frac{S_2}{S} \varepsilon S = \int_{T_1}^{T_2} V T$$

obtains, as in several previous instances, the area beneath this curve is proportional to the distance traversed, i. e., in the first 5 sec., 500 ft. are passed; in a little over 9 sec., 1000 ft., etc. From these figures, the time-distance and velocity-distance curves are plotted in Fig. 7.

As stated at the outset, the object of this article is to compare acceleration with deceleration and to compute the time lost by a slow-down. This relation is now shown on Fig. 8. The values of deceleration are obtained from Fig. 7, and of acceleration from Fig. 4. The upper curve indicates that a 12-lb. brake pipe reduction reduces the speed of the train from 70 to 30 m. p. h. in a distance of 3,200 ft. Then the train runs at a constant speed of 30 m. p. h. for 13,825 ft., and finally accelerates at its maximum rate, possible under the given conditions, from 30 to 70 m. p. h. in a distance of 38,500 ft. It should be borne in mind that under these conditions a locomotive is accelerating at its maximum

period by the values in Fig. 4. Thus, it is found that at the end of the whole period, 4.3 min. are lost.

The importance of considering slow-downs should be realized from the fact that 30 slow-downs, as the above, while seemingly of little moment, delay a train (4.3 x 30) = 129 min. or approximately 2 1/4 hours.

The foregoing calculations are theoretical, and although an attempt to check the above by practical test may result in values slightly varying from these figures, due to differences in the condition of the equipment, methods of manipulation, errors in observations, etc., nevertheless, with care and equipment in good condition, results very close to the calculations should be obtained. In fact, these figures have been found to agree with service conditions on one of the large railroads of this country.

This example should make it apparent that the slowing down of a steam railway train for only a comparatively short distance, causes an appreciable loss in time. In fact, the loss in time, resulting from slow-downs, is one of the reasons why passenger trains are often routed around cities, where stops are not scheduled, rather than have them subjected to the time delaying ordinances necessary for safety within the city limits. Stops or slow-downs, when frequent, very materially reduce the scheduled speed of a train; and should be given careful consideration with the object of minimizing the effects, wherever they occur, because loss in time alone has a direct bearing in reducing the earning capacity of a road.

FOURTH LIBERTY LOAN APPEAL

"We have the Kaiser groggy—let us keep hitting hard now until he is counted out," says Director General McAdoo in his appeal for Liberty Loan subscriptions by railway employees in the coming loan campaign. He says that he wants every railroad man to go the limit in lending his available means to Uncle Sam. He suggests that they begin to save now, and says that no employee can make better use of the back pay recently awarded him than by putting it in Liberty Bonds. The appeal is given in Circular No. 51, the distribution of which to employees was begun recently. This circular follows:

"In order to raise sufficient money to arm, equip and support our gallant soldiers and sailors, to finance our other war activities, and to extend necessary credits to our Allies, to enable them to continue the war against the German military despotism, the Fourth Liberty Loan campaign will begin September 28, 1918. Every loyal American must invest in the securities of his government to the limit of his ability if America is to triumph in this war.

"Railroad men and women are doing a vital service for their country. They responded patriotically to the appeal of the government in the First, Second and Third Liberty Loan campaigns, and I hope that they have bought liberally of War Savings Stamps. They are also operating the railroads, which is war service of primary importance. I am sure that they count it a glorious privilege to do this vital work for their country. I deeply appreciate what they have already done, but there is more to do, and I am sure that they will do more if the way is pointed out to them.

"The enormous sums required to finance democracy's part in the war impose a new duty upon each and every one of us. Liberty Loans must be offered from time to time until the Kaiser is licked to a finish. Each of these loans must be subscribed in full. No patriotic American will have performed his duty by subscribing to one loan only, or by buying a few War Savings Stamps. Each and every one should practice every possible economy, save every possible dollar, and buy as many Liberty Bonds as he can afford every time a Liberty Loan is offered to the country.

"In the Fourth Liberty Loan campaign which is just ahead

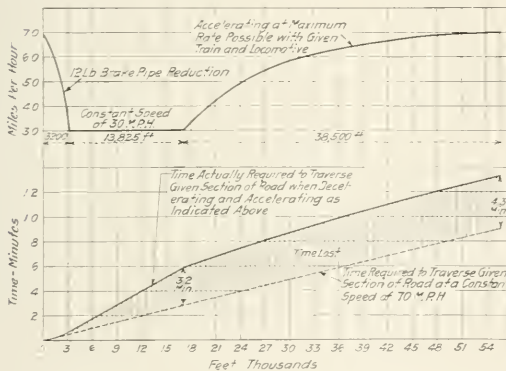

Fig. 8—Velocity-Distance and Time-Distance Curves for a Typical Slowdown

possible rate, while the brakes have only been applied with one-fourth the maximum force for which they are designed. It is evident, therefore, that the brake equipment is many times more powerful than the large superheated Pacific type passenger locomotive. An essential feature of this determination is to ascertain the time lost, i. e., how much longer time is required to traverse the road when the train is decelerated from 70 to 30 m. p. h., under the given braking conditions, run at 30 m. p. h. for a distance of 13,825 ft. and finally accelerated at the maximum rate possible with the given train, to 70 m. p. h., compared to the time to traverse the same section of road at the rate of 70 m. p. h. The dotted line in Fig. 8 represents the time to cover the given section of the road at a constant speed of 70 m. p. h. which may be plotted from the simple relation that a body moving at the rate of 70 m. p. h. covers 102.7 ft. every second. The heavy, solid line, directly above the dotted line, represents the time actually required to traverse the given section of road when the train is decelerated and accelerated, as indicated in the upper portion of Fig. 8. The time curve during the deceleration period can be determined by the values on Fig. 7, during the period the train is running at a constant speed of 30 m. p. h. from the relation that at a speed of 30 m. p. h. 44 ft. are covered every second; and during the acceleration

of us I wish to make a special appeal to every railroad employe to go the limit in lending of his available means to Uncle Sam. Now is the time to prepare for that campaign by saving every possible dollar, so that each may be ready to do his part before the subscription closes. Hundreds of thousands of employes in the railroad service of the United States have received, or will receive, checks for back pay, in accordance with the provisions of the Wage Order I approved May 25, 1918, and Supplement No. 4 to General Order 27, issued on July 25, 1918. No employe can make better use of his back pay than to lend it to the government at interest, thus securing an investment of absolute safety for himself and building up a reserve for a rainy day.

You must remember that you are not asked to *give* your savings to the government; you are asked merely to *lend* your money to your government:—and for what purpose? To back the millions of the finest American boys ever collected together in a great army, and to help them fight irresistibly for our lives, liberties, and vital interests. One and a half million of these splendid boys are already in France, and already they have given the Kaiser a dose from which he is staggering and from which he will not recover. But the pressure must be kept up. Arms, ammunition, and food supplies of all kinds must go forward in a continuous stream if the pressure is to be maintained. It depends upon us who stay at home to keep the pressure applied. We must lend our money to our government, lend it to the limit, so that the government may in turn put in the hands of our splendid sons the things without which they can not fight and without which the defeat of the Kaiser and his hateful military despotism can not be accomplished.

I want the railroad men and women of the United States to do more, if possible, than anybody else, because I want them to be among the first always in patriotism, in service, and in sacrifice to our great and glorious country. We have the Kaiser groggy—let us keep hitting hard now until he is counted out.

RESULTS OF ROAD TESTS OF N. & W. MALLET LOCOMOTIVE

BY H. W. REYNOLDS

In the description of the Norfolk & Western 267-ton Mallet type locomotive, which appeared on page 445 of the August, 1918, issue of the *Railway Mechanical Engineer*, reference was made to the fact that the free steaming qualities of this locomotive had been demonstrated by road tests. The tests referred to were conducted with a dynamometer car in road service on the Pennsylvania Railroad, and data showing the performance of the locomotive during these tests is now available.

After making one trip in road service on the Norfolk & Western the engine was sent under its own steam to Altoona, Pa., and turned over to the Pennsylvania Railroad to be tested on the Pittsburgh division. No special adjustments whatever were made in anticipation of the tests, which were made with the locomotive in exactly the same condition in which it had been turned over to the transportation department for service.

The tests were made on slow freight trains composed of cars of mixed classes and lading, the Mallet type locomotive coupled to the dynamometer car being placed ahead of a Pennsylvania Mikado type locomotive which in turn was coupled to the head of the train. The nominal speed of the test trains was 12 miles an hour, regulated by working the Mikado locomotive to suit grade conditions. The Mallet locomotive was operated at its maximum capacity on most of the tests over practically the entire run.

The distance from the starting to the stopping point of the test was about 22 miles. The difference in elevation

between these two points was 885 feet, corresponding to an average ascending grade of .767 per cent. The ruling grade over which these tests were run was 1.15 per cent, four miles long.

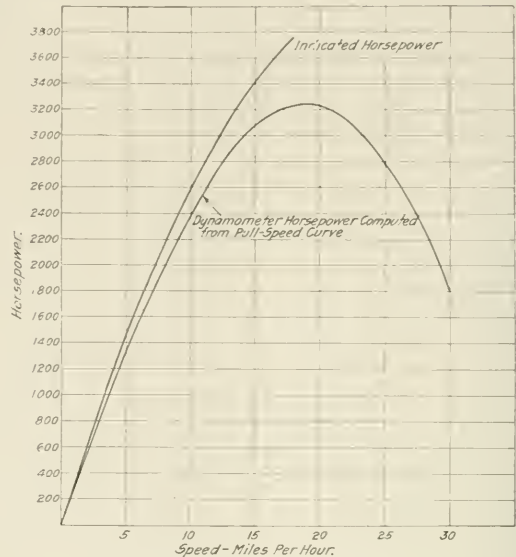

Horsepower Curve for the N. & W. Mallet Locomotive

The figures given below for these tests are averages for the whole trip. They do not represent the maximum output of the boiler that would have been obtained for a shorter period of time or if conditions had been such that the locomotive could have been worked at its maximum

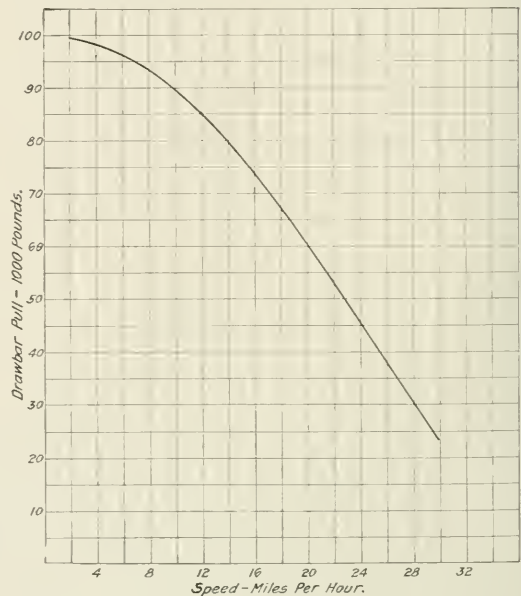

Drawbar Pull-Speed Curve of the N. & W. Mallet Locomotive

boiler capacity during the entire time it was actually running.

TABLE I—BOILER PERFORMANCE

	Maximum	Minimum	Average for tests
Average steam pressure, lb. per sq. in.	330	224	227
Total dry coal fired, lb. per hr.	8,679	5,053	7,140
Dry coal fired, lb. per hr. per sq. ft. grate	90.41	52.63	73.4
Total equivalent evaporation, lb. per hr.	68,006	44,787	56,720
Equivalent evaporation, lb. per hr. per lb. dry coal	7.86	7.08	8.01
Equivalent evaporation, lb. per hr. per sq. ft. heating surface	8.66	5.71	7.23
Boiler horsepower	1,971.2	1,298.2	1,644.0
Efficiency of boiler, per cent.	66.41	46.47	55.0

The principal items of boiler and engine performance are given in Tables I and II, respectively. Data relative to the

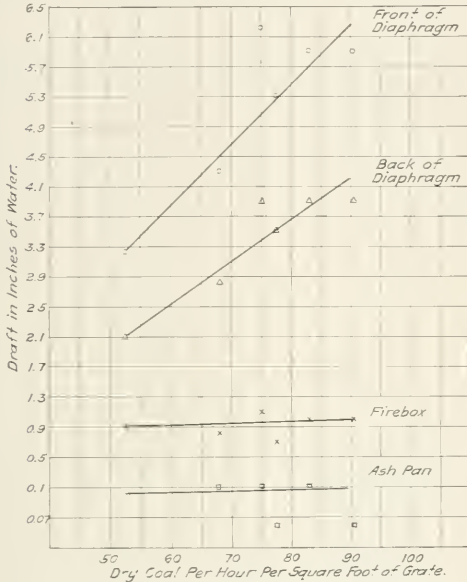

Draft Conditions Recorded in the Road Tests of the N. & W. Mallet Locomotive

performance of the locomotive as a whole is given in Table III.

TABLE II—ENGINE PERFORMANCE

	Maximum	Minimum	Average for tests
Speed, miles per hour	12.93	8.16	10.5
Average boiler pressure, lb. per sq. in.	239	224	227
Average lb. of engine steam per sq. in. per hr.	203	131	194
Average lb. of engine steam per sq. in. per hr. per sq. ft. of grate	4.15	1.91	2.90
Average lb. of engine steam per sq. in. per hr. per sq. ft. of grate	1,251	1,079.5	1,177.7
Average lb. of engine steam per sq. in. per hr. per sq. ft. of grate	67	49	62
Average lb. of engine steam per sq. in. per hr. per sq. ft. of grate	96	67	81
Average lb. of engine steam per sq. in. per hr. per sq. ft. of grate	1,226.5	1,079.5	1,152.5
Average lb. of engine steam per sq. in. per hr. per sq. ft. of grate	2,305.8	2,538.9	2,422.3
Total indicated horsepower	54.65	52.85	53.6
Per cent. of full rated h.p. in cylinders	17.82	15.21	16.56

The back pressure in the cylinders for a range in steam consumption between 57,000 to 50,000 lb. per hour was 70 to 75 lb. in the high-pressure cylinders and from 4 to 6 lb. in the low-pressure cylinders.

TABLE III—PERFORMANCE OF THE LOCOMOTIVE AS A WHOLE

	Maximum	Minimum	Average for tests
Average tractive effort, lb.	12,043	8,116	10,5
Average boiler pressure, lb. per sq. in.	63,800	50,439	58,850
Maximum boiler pressure, lb. per sq. in.	88.71	85.92	87.07
Dry coal, lb. per hr.	315	243	279
Dry coal, lb. per hr. per sq. ft. of grate	17.82	15.21	16.56
Dry coal, lb. per hr. per sq. ft. of grate	3.89	3.19	3.52
Steam, lb. per hr. per sq. ft. of grate	21.20	17.51	19.46

As the calculated tractive effort of the locomotive when working compound is 104,350 lb., the maximum draw-bar pull developed was greater than could be recorded by the

dynamometer car, which had a capacity of 100,000 lb. The greatest recorded pull was 97,600 lb. which, when corrected for grade and acceleration, was 106,100 lb. at 1 m. p. h.

The draw-bar pull curve shown was obtained from instantaneous pulls taken from the dynamometer records, corrected for grade and acceleration. Over the ruling grade on one test the average draw-bar pull was 71,940 lb. at an average speed of 12 miles an hour. The corresponding pull on level tangent track would have been 80,540 lb. During this test the locomotive was worked in full gear with a wide-open throttle and an average steam pressure of 227 lb. On another test the average draw-bar pull exerted by the locomotive over the same grade was 73,600 lb., corresponding to a pull on level tangent track of 82,200 lb. The average speed on this test was 11.6 miles an hour, and an average steam pressure of 230 lb. was maintained.

Had it been possible to have recorded the maximum draw-bar pull with the engine working simple, the draw-bar pull curve would have gone considerably higher than shown, for the calculated simple tractive effort of the locomotive is 135,000 lb.

M. K. & T. PULVERIZED COAL TESTS

In the October, 1916, issue of the *Railway Mechanical Engineer*, page 499, there appeared a description of the equipment installed at the power house of the Parsons shops of the Missouri, Kansas & Texas for the preparation and burning of pulverized coal. At that time some tests had been made on one of the boilers using several varieties of coal, and a brief summary of the results was included in the article. In June, 1917, another series of tests was conducted. A brief summary of the results of these tests is given in the tables:*

TABLE I—SUMMARY OF PULVERIZED COAL TESTS AT M. K. & T. SHOPS.

Kind of fuel ¹	Lignite, Texas		Semi-Chemical slack, Kansas		Anthracite, Kansas	
	4.5	4.0	3.5	3.5	3.5	3.5
Duration of test, hours	4.5	4.0	3.5	3.5	3.5	3.5
Boiler pressure, gage lb.	137.5	136.0	135.5	135.5	135.5	135.5
Draft, inches water:						
At damper	0.992	0.955	0.000	0.000	0.000	0.000
Top third pass	2.148	0.083	0.075	0.075	0.075	0.075
Bottom second pass	0.119	0.105	0.070	0.070	0.070	0.070
Top first pass	0.639	0.021	0.019	0.019	0.019	0.019
Furnace	0.982	0.051	0.033	0.033	0.033	0.033
Furnace temperature, deg. F.	2,352.0	2,354.0	2,403.0	2,403.0	2,403.0	2,403.0
Stack temperature, deg. F.	597.9	554.6	624.3	624.3	624.3	624.3
Gas at end of flame:						
CO ₂	16.47	15.1	16.5	16.5	16.5	16.5
O ₂	9.93	2.9	1.9	1.9	1.9	1.9
CO	0.24	0.1	0.0	0.0	0.0	0.0
N	81.6	81.9	81.6	81.6	81.6	81.6
Gas at stack:						
CO ₂	14.75	14.8	15.8	15.8	15.8	15.8
O ₂	5.05	5.5	3.0	3.0	3.0	3.0
CO	0.00	0.00	0.00	0.00	0.00	0.00
N	80.20	81.7	81.2	81.2	81.2	81.2

Proximate analysis of coal:			
Moisture	17.06	1.96	0.30
Volatile, dry	61.5	32.4	23.9
Fixed C, dry	24.72	49.57	59.94
Ash, dry	13.76	18.02	17.77
Sulphur (separately determined)	0.98	5.14	4.09
B.t.u. per lb. as fired	8,854.0	12,056.0	12,387.0
B.t.u. per lb. dry coal	10,675.4	12,185.0	12,625.0
B.t.u. per lb. combustible	12,378.0	14,863.0	15,352.0

*The data in the tables and the discussion of the tests are abstracted from an article by H. R. Collins and Joseph Harrington which appeared in the *General Electric Review* for October, 1917.

Three different fuels were tested having a considerable range in quality. The first test was of Texas lignite, which had been stored in the open air over six months, and sub-

jected to freezing and thawing, and the influence of the sun and wind all this time. It was not necessary to dry this lignite to the same degree that the other coals were dried, and the 17 per cent of moisture in the coal, as fired, did not affect its apparent quality at all. To all appearances, it was as fluid as the semi-anthracite coal containing only 0.3 per cent moisture. The second coal was a fairly high ash, high sulphur coal from southern Kansas, and is the coal which is usually burned at this plant. For the last test a car load of semi-anthracite screenings was obtained. This coal was very fine when received, and was stated to be of a kind which is unsalable on account of its size.

It was not possible under the conditions obtaining at the time to conduct tests even as long as eight hours, so that tests of shorter duration were made. While these tests may appear to be short as compared with the accepted practice in mechanical stoker testing, it must be remembered that the amount of fuel actually in the furnace at any one time, is represented by a very few pounds, and that when the feed screw is suddenly stopped, the combustion as suddenly ceases.

One point of particular interest is the heat balance, which indicates conditions unusual in boiler testing. The boilers themselves were O'Brien boilers, which had been rebaffled to provide three cross passes for the gases, and inability to clean the heating surface of these boilers by hand resulted in

cent ash pit loss. The ash pit loss with stokers will run from 2 to 5 per cent, so that there is in stoker practice from four to ten times as much ash pit loss as with powdered coal.

During these tests there was a light gray haze apparent at the top of the stack. A sample of dust was obtained from the breeching, which was very fine in size and of a gray color. Analysis showed that there was two per cent of combustible matter in the fine dust.

Another matter bearing on the high furnace efficiencies is the item of heat absorbed by excess air. It was without the slightest difficulty that the CO₂ in the flue gases was carried up to 16 per cent, readings frequently going to 17 per cent, and but few readings being less than 15 per cent. Considerable care was exercised in making the analysis for CO, there being the natural thought that with the high CO₂ that some loss from incomplete combustion might occur. The CO loss was in direct proportion to the length of the flame. Some relation, therefore, between the proportion of volatile matter in the fuel and the CO loss becomes apparent.

Pyrometer readings showed a furnace temperature between 2300 deg. F. and 2400 deg. F., under which conditions brick work may be maintained indefinitely, and which is above the fusing point of the ash from many coals. This furnace had been in constant service for nine or ten months, and the interior was in perfectly good shape.

TABLE II. HEAT BALANCE PER POUND OF COAL

	Texas Lignite		Cherokee Slack		Semi-Anthracite	
	B.t.u.	Per cent	B.t.u.	Per cent	B.t.u.	Per cent
Heat per lb. coal as fired.....	8,854	100.00	12,656	100.00	12,587	100.00
Heat absorbed by water in boiler.....	5,073	57.32	6,992	58.00	8,765	69.94
Necessary Losses:						
Heat to moisture and burned H. up to temp. of steam.....	581	6.56	473	3.92	365	2.90
Heat to theoretical amount dry gas up to temp. of steam.....	441	4.98	618	5.13	607	4.82
Heat available for use.....	7,832	88.46	10,965	90.88	11,615	92.72
Highest theoretical efficiency.....						
Furnace Losses:						
Heat to excess air up to steam temp.....	50	0.57	100	0.83	67	0.53
Heat loss due to CO.....	75	0.86	44	0.37
Heat available for boiler.....	7,707	87.05	10,821	89.76	11,548	91.73
Furnace efficiency.....		98.40		98.69		99.44
Boiler Losses:						
Heat to theoretical amount of dry gas, moisture and H. above steam temp.....	465	5.25	438	3.64	675	5.36
Heat loss due to air leakage through setting.....	120	1.36	29	0.24	52	0.41
Radiation and unaccounted for losses.....	2,049	23.12	3,362	27.88	2,056	16.33
Boiler efficiency.....		65.82		64.61		71.90
Combined efficiency.....		57.32		58.00		69.64
Ratio comb. eff. to highest theor. eff.....		64.80		63.90		73.49

one-half of the heating surface being particularly dirty. To this may be ascribed much of the inefficiency of the boiler. Gas temperatures nearly 200 deg. F. in excess of what could properly be expected were obtained at the stack.

The next item of interest is the very high furnace and grate efficiency. The ash pit in this case had a sloping bottom, and was visible throughout its extent from the door in the basement. Previous to these tests the pit was substantially clean and the condition noted. In the case of the Cherokee slack, the ash fused and ran down the bottom in molten streams, being removed partially in liquid form and partly by being broken away from the bottom with a bar after it had somewhat cooled. An examination of a piece of cold slag shows an appearance like that of black glass, without the slightest sign of any combustible.

Under the ordinary operating conditions of this plant using this coal and operating at times at low ratings, there is produced a mixture of fine sandy looking ash and melted slag. Examination of a car load of this refuse standing on the side track of the plant failed to reveal any traces of unburned coal or coke. A sample was secured by taking a little from various parts of the car which analysed as follows:

Per cent moisture.....	13.00
Per cent ash, dry basis.....	97.40
Per cent combustible matter, dry basis.....	2.60

If all of the refuse could have been collected and weighed the weight would have been equal to 18.50 per cent of the dry coal fired. There would have been, therefore, 0.48 per

The ash from the lignite and semi-anthracite coals did not fuse, and there was a small deposit in the ash pit of a yellow sandy looking ash which appeared to be entirely free of combustible matter.

Another and most interesting phase of these tests is the draft loss in the boiler. A drop in draft between the top of the third pass and the furnace of around 0.05 in., in a boiler ten tiers of tubes in height, operating at 25 or 30 per cent above its rating, does not seem natural, but the draft readings throughout all three tests were checked and repeatedly verified. These boilers are equipped with 60-ft. stacks, and were operated with the stack damper partially closed in order to get the furnace draft nearly neutral. The small loss is probably due to the small gas volume and consequent low frictional resistance in the boiler.

There is without doubt a certain amount of the ash dust which adheres to the furnace walls, and if such ash has a fluxing effect on the brick, ultimate destruction will occur. On the other hand, if it is desirable to liquefy the ash the furnace can be designed to produce a temperature which will be above the fusing point, and the substantially complete removal of the ash in this form thereby effected.

One of the questions which heretofore has frequently been asked is relative to the slagging of the tubes from fused ash adhering thereto, and forming an objectionable coating on the exposed surfaces. During the three days when these boilers were under observation there was no sign of any formation of this nature.



RECLAMATION ON THE SOUTHERN PACIFIC

A Description of the Extensive Salvage Work Done
in the Largest Railroad Shop on the Pacific Coast

BY FRANK A. STANLEY

II

IN the first installment of this article reference was made to the reclamation at the scrap docks of the Sacramento shops of many such items as bolts, oil box covers, shoe and wedge lining, washers, valves, and numerous other parts that admit of being put into serviceable condition and are, therefore, in a class distinctive from the material that is actually scrapped and sent to the foundry, mill and forge for

BOX COVERS, SHOES AND WEDGES

The pile of parts in Fig. 14 is a portion of a considerable accumulation of oil box covers that arrive in great numbers at the scrap docks. These are in some instances sheet metal stampings, in others malleable castings. In either case the work of reclamation consists in heating and straightening the flat covers, straightening out the hinge ends for the pins, closing the ends where sprung open, etc., all operations performed in the smithy on the scrap docks.

The view in Fig. 15 shows a pile of shoes and wedges on the reclamation platform where the brass is melted out as mentioned in the article last month. The furnace for the work is seen at the left and as there indicated it is fired by oil fuel. The amount of brass thus saved from old shoes and wedges will run to about 2,600 lb. in two weeks' time. Ma-

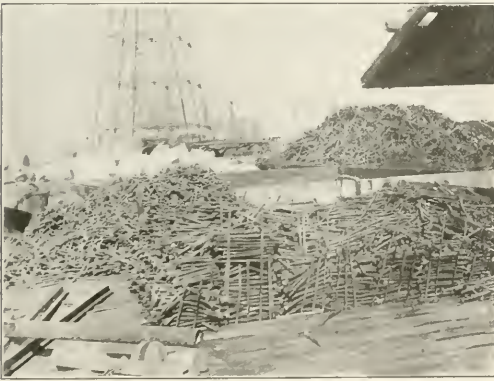

Fig. 13—Sorted Bolts Ready for Reclaiming

working into castings and stock for fresh material. The sorting out of parts suitable for immediate reclamation is a process that is carried on with as great a degree of celerity as possible and as rapidly as any group of bolts, covers or other pieces is accumulated in sufficient numbers the parts are run through the necessary operations to make them suitable for storing and issuing as required.

Thus, in Fig. 13, a number of piles of bolts and nuts are represented as sorted for reclaiming, an undertaking accomplished by the simple operations of cutting off the worn threaded ends, straightening the body, rethreading, and in the case of the nuts, retapping. The principal bolt shop is naturally located in the main shops and where bolts and nuts are overhauled in great quantities much of the work is sent there from the reclamation docks.



Fig. 14—Oil Box Covers to be Straightened

material of this nature is constantly coming in from all over the system and the total saving of brass from various classes of parts runs into a very high figure.

CAR BRASSES

Along this line few features of the reclamation project are more important than the saving of material in the way of old

car brasses, which by the way, are overhauled in the main plant, in the Babbitt shop. Formerly up to ten or a dozen years ago, practically all car and truck brasses, as the babbitt lining wore out or burned out, were discarded and sold to the junk dealers and entirely new brasses put into their places. Now the old brasses all come back to the babbitt shop at the Sacramento plant and are here relined with new babbitt unless worn too thin for further service, or too short on the ends for use.

This means a considerable saving of old babbitt which is



Fig. 15—Furnace for Melting Liners from Shoes and Wedges

melted out of the brasses and a much more important saving in the brasses themselves, which under usual conditions of service will last for a good many years. Some conception of the extent of operations in this direction is gathered from the fact that the babbitt shop referred to relines as many as 3,000 old brasses in the course of a month, this in addition to an output of new brasses running up to some 4,500 in number.

In these operations and in pouring other classes of work the babbitt shop will run about a ton of babbitt a day. For

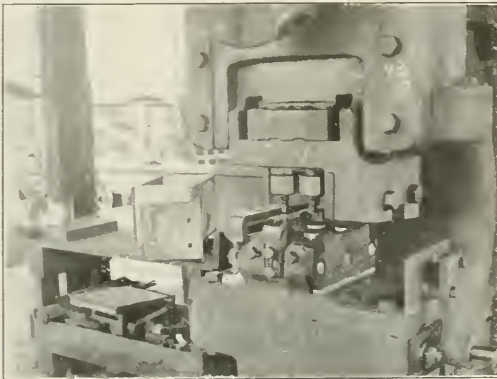

Fig. 16.—Gang Punch for Tie Plates

brasses alone the babbitt used per month runs up to over 40,000 lb., about 20 per cent of this going into the relining of old brasses and the remainder into new work.

Old babbitt recovered from worn brasses, from cross-heads, etc., constitutes the bulk of the material required for pouring both old and new brasses. To this reclaimed babbitt enough new metal is, of course, added to bring the material up to the analysis to which the lining metal must be held.

MAKING UP BILLETS FOR TIE MILL

Returning now to the reclamation docks proper, a large number of box-piles ready to be sent to the rolling mills are shown on the platforms, in the illustrations at the head of this article. The box-pile is built up on a board, on which binding straps of flat stock are placed, with the scrap piled between sections of plate which have been cut roughly to size by power shears and flame cutting torch.

The assortment of scrap bolts, rod ends, pins and so on is built up neatly and then bound by closing the straps in an air operated machine. The finished box-piles are placed on carrying stands, each holding a half-dozen or more box-piles, which are made up of a stiff metal skeleton form that admits of being picked up and moved about by the lifting truck shown in the illustrations. This truck is backed under a stand and then a pull of the upright lever lifts the truck body and clears the stand and its load from the floor, so that it may be transferred easily to any other point in the shop and as easily deposited.

The box-piles are hauled on flat cars around to the mill siding and there unloaded for the heating furnaces. Several long rows of stands with their billets in front of the mill department are shown in the center photograph. The lifting trucks are here also used in numbers for transporting the material about the mill and yard platforms.

The roughed square stock as it issues from the mill rolls



Fig. 17—Some of the Sizes of Bolts Manufactured

is seen piled up in short working lengths in the right-hand photograph. Merchant bar products are made in great quantity in rounds, squares, flats and other sections for general use and manufacturing purposes in the various shop departments.

PUNCHING TIE PLATES

Tie plates are manufactured in large numbers. The method of punching them is illustrated in Fig. 16. There are four punches combined in one gang for forming all four holes at one stroke of the machine. The dies carry the shear at the right hand side, the stop further to the right and a stripper is placed across the center of the die block to clear the four round dies inserted in the face of the block.

Some of the large sizes of bolts and nut blanks manufactured are seen in Fig. 17. The nuts are produced by heading up the end of the round bar as in forming a bolt head, and then punching through the center of the hexagon head and so forcing out the core of the nut blank as an integral part of the round bar of stock. One set of dies upsets the hexagon form on the end of the hot metal and then the bar is dropped into the lower die for the punching out of the center, which clears the bar from the pierced nut blank.

will be seen that there is a slight increase of stress in the fourth test over that in the first test along the bottom or tension member at certain points.

By averaging these tension stresses on the bottom member from just outside of the outer set of holes to a point just inside of the inner set of holes we obtain 11,300 lb. stress per sq. in. without the holes in the bolster and only 300 lb. increase in stress with the 12 holes in the bolster, showing that the addition of these holes did not have any material effect upon the stresses developed in the bolster.

Comparing the stresses around the holes in Fig. 3 it will be seen that they are somewhat higher than the stresses shown around the holes in Fig. 10 of the previous paper. This is due to the fact that there were no beads around the holes of

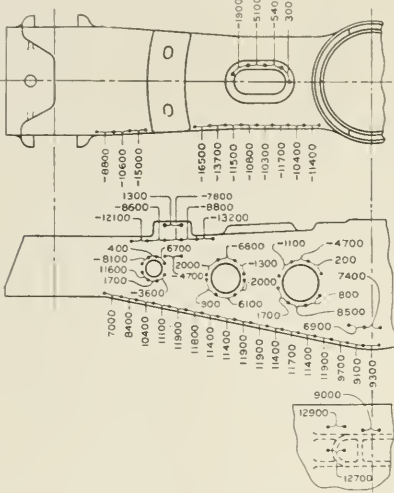

Fig. 3—Stresses under 150,000-Lb. Combined Load with Holes in the Side Walls

the bolster used in the later tests. However, it will be seen that there is no stress, even without the beads, that is at all serious.

It has been claimed by some foundrymen that casting box bolsters with holes in the side walls will materially reduce the foundry losses.

The results of all the tests conducted by the writer show clearly that a stronger bolster can be made by straightening the bottom of tension member, closing the usual holes in the bottom and for foundry requirements casting holes in the sides as indicated. Small holes in the side walls of a box bolster have no appreciable effect on its strength, provided the holes are properly located and of a size that will not decrease the transverse strength.

WHERE GERMANY SECURES COPPER.—Before the war Germany obtained most of her copper from the United States, taking over one-third of our exports. Since Germany has extended her sphere of influence it is probable some supplies are coming from other countries. The Serbian copper mines are now being intensively exploited by the Germans and Austrians, and good copper deposits are also said to have been found in Poland. Work has begun in lead and copper mines in Kielce; and in Miedziana, Lysa Gora and Olkuss the methodical exploitation of these ores has recently been started.—*The Value World*.

BRAKE PIPE LEAKAGE

In discussing a paper on the question of Air Brake Maintenance before the New England Railroad Club, H. S. Walton, supervisor of air brakes, Boston & Albany, spoke on brake pipe leakage, saying, in part, as follows:

"The practice of the train men pulling the air hose apart results in a great deal of trouble as it causes leaks in the train pipe. It not only injures the hose, ruptures the lining and causes it to become porous, and injures the couplings themselves, but the constant shocks applied to the brake pipe itself by pulling the hose apart eventually loosen the joints. All roads should instruct the trainmen to separate the hose by hand and we should see that they *do it*. To show how expensive brake pipe leakage may be I will quote from a paper which I prepared and read before this Club in January, 1917:

"Brake pipe leakage is very expensive when we consider the wear and tear of the pump and the additional consumption of fuel. Let us consider the latter in connection with a 70 car train assumed to have one-half eight-inch, and one-half ten-inch equipment. A leakage of 5 lb. per minute on this train, with a 70 lb. train pipe pressure would amount to 39.5 cu. ft. of free air per minute, or 23,700 cu. ft. of free air in ten hours. The 8½-in. cross compound pump, driven with 200 lb. steam pressure would require 3 hours and 5 minutes to compress the air lost, and in doing that amount of work 5.782 lb. of water would be evaporated; and assuming that 8.5 lb. of water is evaporated with one pound of coal 680 lb. of coal would be consumed.

"The New York No. 5 pump would require 3 hours and 20 minutes to do the same amount of work and would use 10,475 lb. of water and 1,230 lb. of coal. For the 9½-in. pump this work would require 9 hours and 11 minutes with 15,144 lb. of water and 1,780 lb. of coal."

"If there is any one connected with a railroad in this section of the country that can find a 70-car train with a leakage as low as 5 lb. per minute I will pay for this dinner tonight. If you add to the air wasted in brake-pipe leakage the air wasted in making sufficient reduction to develop the maximum braking power of cars with a long piston travel, you will find that it will greatly increase the consumption of coal used or required to compress air that is wasted, and I don't need to tell you what coal is worth in these days. It is almost as valuable as gold."

C. H. Larimer of the Westinghouse Air Brake, who was also present at the meeting, said:

"In this territory the most of the caboose cars have been equipped with a pressure gage connected to the brake pipe line and it will no doubt be interesting to know just what a difference in the gage pressures between the forward and rear end of the train indicates in number of cubic feet free air leakage per minute. With a train of fifty cars, 70 lb. pressure on the first car and gage in the caboose reading 67 lb., it would indicate a loss due to leakage of 58.7 cu. ft.; a 5 lb. difference, a loss of 52 cu. ft.; a 7 lb. difference, a loss of 61 cu. ft., and should the pressure be held at 70 lb. on the first car with a drop of 20 lb. on the gage in the caboose it would mean that 106 cu. ft. of air is being wasted due to the leakage. Looking at this leakage in the light of an expense, that the most economical compressor uses 30 lb. steam per 100 cu. ft. free air compressed, and that the modern locomotive with its superheater, arch, combustion chamber and feed water heater evaporates 10 lb. of water to a pound of coal, with coal at \$10 a ton, the cost of displacing 100 ft. of air would be \$0.15. A ten-hour run would mean then that 60,000 ft. of air would be lost at a cost of \$9. If the difference between the first car and the caboose was 7 lb. which it is frequently, the loss would amount to, on the same basis, \$5."



LARGE CAPACITY WOODEN HOPPER CAR

Built by the N. & W.; King Post Side Trusses;
Large Pocket Castings Extensively Used in Fanning

DURING the latter part of 1917 and early in 1918 the Norfolk & Western started the construction of 2,000 cars, all but ten of which are of composite wood and steel construction. These cars are built up on a steel center sill and bolster foundation, the remainder of the construction being wood throughout. Ten of the cars were built of wood throughout, including the center sills and bolsters, largely for the purpose of demonstrating the possibilities of all-wood construction in cars of this capacity. With the exception of the center sills, bolsters and draft gear attachments, both the all-wood and the composite cars are practically identical in design.

The cars of all-wood construction are built up on continuous center sills of 6-in. by 12-in. section placed 15½ in. apart. The bolsters are made up of two 16-in. by 20-in. timbers which are spaced 4½ in. apart and are placed over the center sills. These timbers are attached to the center sills by means of the center plate casting, which is designed to form a filler both between the center sills and the bolster members. Further means of attachment is provided by cast iron brackets attached to the outside faces of the center sills and to the bottom of the bolster members. These brackets are also provided with fillers which extend upward between the bolster members.

The draft gear, which is the Sessions Type K, is carried directly by the center sills, the center line of the gear being located 44 1/16 in. above the lower face of the sills. The pulling stresses on the draft gear are transferred directly from the bolster plate to the check plate. Each check plate is secured with four vertical keys, which fit into the cross girders of the sills so that the stress is delivered against the end grain of the wood, the bolts only serving to hold the key plates against the sills. In order that the forward keys may be kept well back from the ends of the sills, the coupler shank is made 28 in. long. In buffing the coupler yoke bears directly against a projection on the center plate casting, and the check plate members on the sills are subjected to stress

in but one direction. Buffing sills of 4-in. by 8-in. section are placed between and flush with the bottom of the center sills. The ends of these timbers are fitted in pockets in the back of the center plate castings so that the buffing stresses are transmitted directly through the center plate casting to the end grain of the buffing sills, and no shearing stress is imposed on the bolts by which the casting is attached to the center sills.

End sills of 4½-in. by 12-in. section are placed across and directly above the center sills, to which they are bolted. The ends of the center sills are thus supported from the side frames of the car and also from the trussed hopper end by 4½-in. by 4½-in. posts placed in the outer angles between the center sills and the end sill. The ends of the center sills are tied together and capped by a malleable iron casting to which is attached the coupler carrier iron and the dead wood block. The latter is 8 in. deep by 4 in. high and is faced with a steel plate 1½ in. thick. The carrier iron is a 5-in. by 3½-in. by 7 1/16-in. angle 27 1/8 in. long with the horizontal flange turned up to form the coupler limit stops.

The car bodies are designed in the form of king post side trusses, which relieve the center sills of a large part of the weight of the lading. These trusses have 4½-in. by 9-in. side sills, and 4½-in. by 6-in. plates, between which are three 4½-in. by 4½-in. posts, two of which are located at the bolsters and the other at the center of the car. Main diagonal members of 8-in. by 4½-in. section extend from the top of the car at the center to footings at the bolsters, the connection at this point being made by a large iron pocket casting the keys of which are gained into the side sills. The tension member at the center of the truss consists of two 7-in. U bolts, which straddle the frame and are secured below the center sills. Where the bottom of the hopper chutes are secured to the sills, they are supported directly from the main diagonals by 7-in. tension members, the truss form being retained at these points by the use of 4½-in. square diagonal compression members, which carry their load

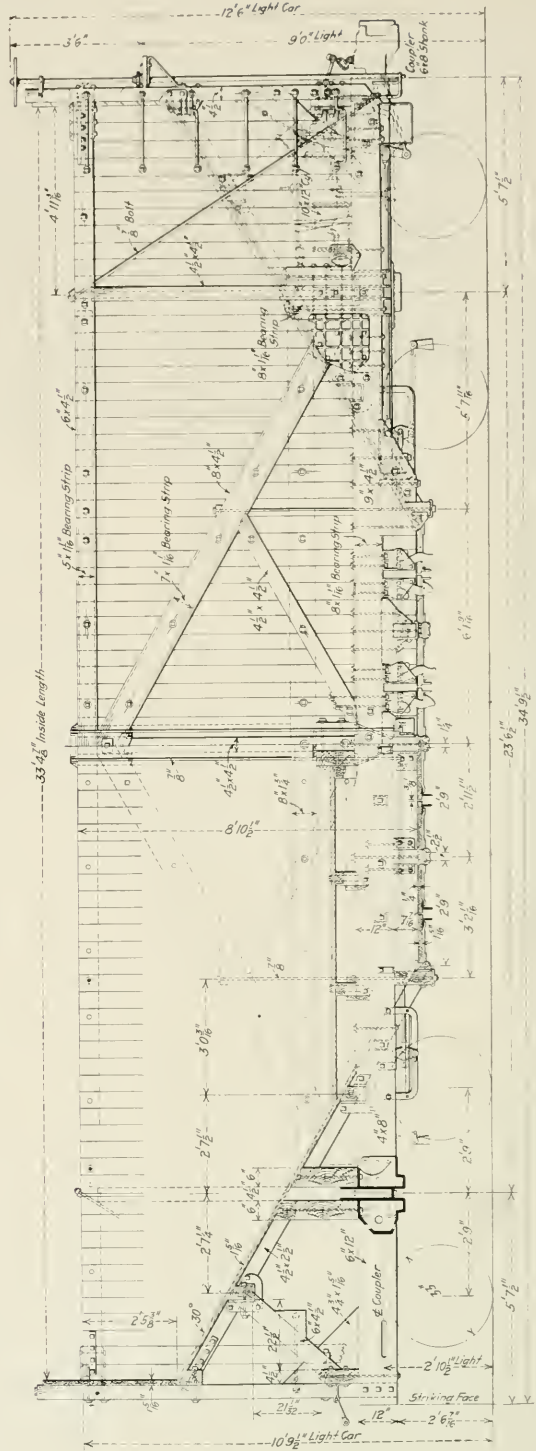
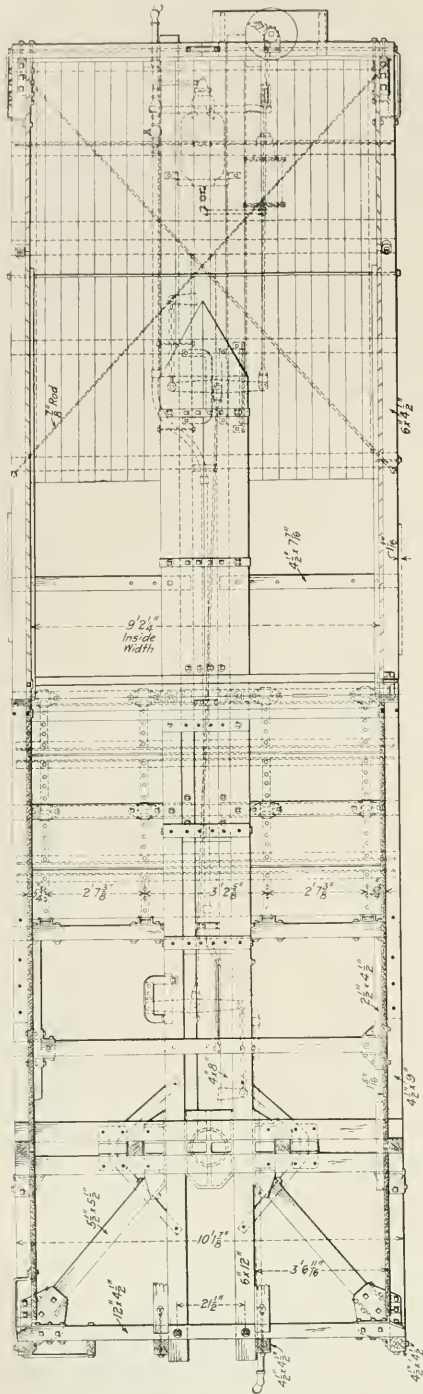

Plan and Elevation of the N. & W. Wooden Hopper Car

to the main vertical tension member at the center of the truss. The overhang of the side frames at the ends of the car is supported by $7/8$ -in. diagonal rods.

The load on the center sills at the middle of the car is transferred across to the side frame by a needle beam made up to two $4\frac{1}{2}$ -in. by 12-in. pieces placed across the car above the sills.

The car has four sets of double doors, hinged from cross-timbers, supported from the side and center sills. These doors clear about 2 ft. 9 in. in width and extend continuously across the car. When the doors are closed they are supported only at the ends, the edges of the doors being reinforced by angle irons of sufficient stiffness to support the load between the sides of the car. The ends of these angles project slightly beyond the sides of the car, where they engage the hooks which hold the doors closed. The door locking device is simple in construction. It is manufactured by the Wine

to the side frame members, with every support board bolted in place. On the inside of the car horizontal retaining strips are attached to the sides to prevent the board from being loosened from the frame by the pounding, which is often necessary to dislodge the coal in the car. The chute boards, beside being supported at both ends and over the bolsters, are provided with two intermediate supports attached to the side planking of the car by cast iron pockets of ample dimensions. The lower one is gained over the center sills, and the upper one is supported from the end sill by 6-in. by 4-in. diagonal struts. Beneath the chute are two diagonal truss rods, each running from the top of the chute at one side of the car to the bottom of the chute at the other side. The chute is thus in effect a diagonal transverse truss which holds the side frames securely in alignment, and resists any tendency towards weaving of the whole structure. The sides of the car are tied together at the top by five $7/8$ -in. cross bolts.

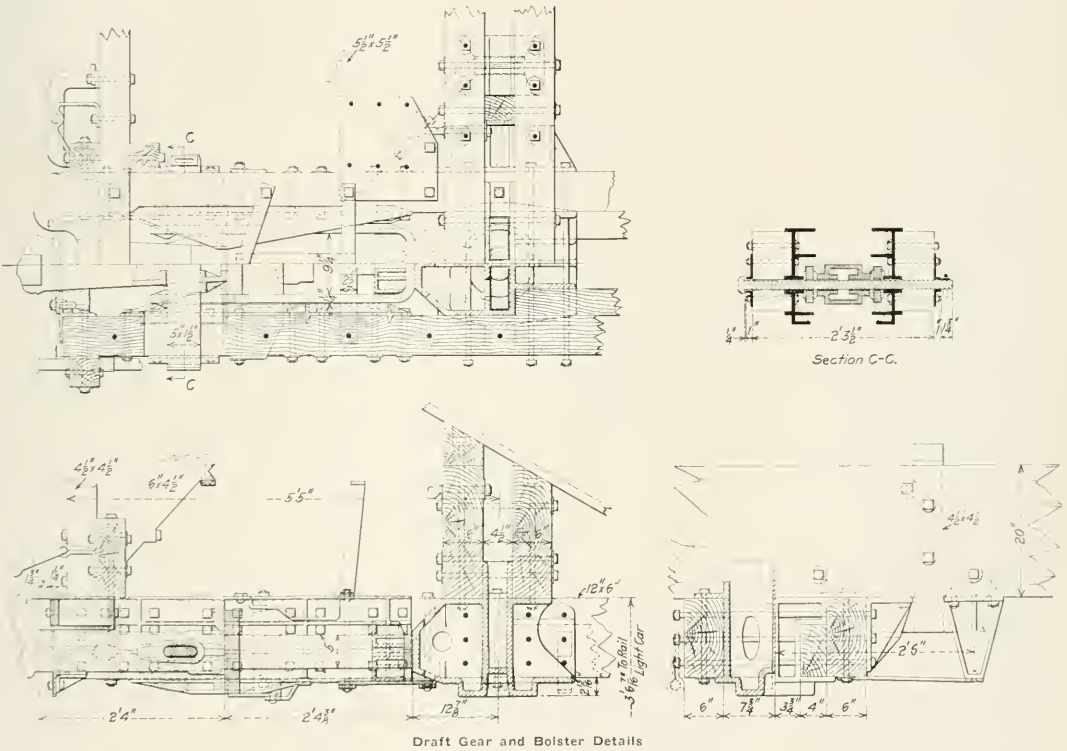

Railway Appliance Company and is the same as that used on the 100-ton steel hopper coal cars of the Norfolk & Western.*

It will be seen that the arrangement of the doors is such that half of the load at the inside of the doors is carried by the center sill and half by the side sills, while the total load at the swinging side of the doors is supported by the side sills. The center sills thus support one-quarter of the total load resting on the door, and this is in turn transmitted to the side frames through the bolsters and the needle beam at the center of the car.

The siding and chutes are made of ship lapped material 1 5/16 in. thick. The siding is applied vertically and spiked

The design of the car is characterized by the extent to which use has been made of pockets and corner castings of liberal dimensions for the connection of the various members of the frames. These are provided with keys gained into the wood members, whenever the stress tends to exert a shearing action on the bolts by which they are attached to the wood.

The trucks are built up of cast steel side frames and bolsters and have $5\frac{1}{2}$ -in. by 10-in. journals. The wheels are cast iron, 33 in. in diameter, and the wheel base is 5 ft. 6 in.

Some of the all-wood cars have now been in service as long as seven and eight months, and have been handled in heavy trains made up largely of steel cars. A recent examination indicates that so far there has been no shrinking of the wood or other loosening of the joints in the frame structure. As far

*See the Railway Mechanical Engineer for February, 1918, page 96.

as may be judged from this limited period of service, the design is a successful one.

The following are the more important dimensions of the all-wood cars:

Length inside	33 ft. 4 7/8 in.
Coupled length	37 ft. 1 in.
Distance between track centers	23 ft. 6 1/2 in.
Inside width	9 ft. 2 1/2 in.
Width to clear	10 ft. 4 in.
Top of sides above the rail	10 ft. 9 1/2 in.
Capacity	57 1/2 tons
Light weight	24,300 lb.
Cubic capacity level	1,192 cu. ft.
Cubic capacity with 30-deg. heap	1,350 cu. ft.

ALLOCATION OF THE 100,000 STANDARD CARS

The following table gives the allocation of the Railroad Administration's 100,000 standard freight cars as determined by the Division of Operation. It will be noticed that the cars are well distributed, only two roads, the Pennsylvania line west and the Baltimore & Ohio, being allocated over 5,000 cars. The Pennsylvania lines east and the New York Central proper will each receive 4,500.

ALLOCATION OF 100,000 STANDARD FREIGHT CARS

Railroad	No.	Type of car
Ann Arbor	300	Single sheath box
Atlanta, Birmingham & Atlantic	200	Single sheath box
Atlanta, Birmingham & Atlantic	150	Gondola—drop bottom
Atlantic Coast Line	500	Single sheath box
Atlantic Coast Line	750	Gondola—drop bottom
Atchison, Topeka & Santa Fe	1,700	Double sheath box
Atchison, Topeka & Santa Fe	1,000	Gondola—drop bottom
Bangor & Aroostook	1,000	Double sheath box
Big Four	1,000	Hopper
Bessemer & Lake Erie	500	Hopper
Boston & Maine	1,500	Single sheath box
Boston & Maine	1,000	Gondola—drop bottom
Baltimore & Ohio	2,000	Single sheath box
Baltimore & Ohio	500	Gondola—low side
Baltimore & Ohio	1,000	Gondola—drop bottom
Buffalo, Rochester & Pittsburgh	800	Hopper
Carolina, Clinchfield & Ohio	300	Single sheath box
Carolina, Clinchfield & Ohio	750	Hopper
Chicago & Alton	500	Gondola—drop bottom
Chicago & Western Carolina	300	Single sheath box
Chicago, Burlington & Quincy	1,500	Double sheath box
Chicago & Northwestern	2,250	Double sheath box
Chicago & Northwestern	1,000	Gondola—drop bottom
Chicago, Indianapolis & St. Louis	300	Double sheath box
Cincinnati, Indianapolis & Western	300	Gondola—drop bottom
Central of New Jersey	1,000	Single sheath box
Central of New Jersey	1,000	Gondola—low side
Chicago & Eastern Illinois	500	Hopper
Chicago & Eastern Illinois	500	Double sheath box
Chicago & Eastern Illinois	500	Gondola—drop bottom
Chesapeake & Ohio	2,000	Single sheath box
Chesapeake & Ohio	2,000	Hopper
Colorado & Southern	300	Double sheath box
Chicago, Rock Island & Pacific	1,000	Double sheath box
Chicago, Rock Island & Pacific	1,000	Gondola—drop bottom
Chicago, St. Paul, Minn. & Omaha	1,000	Double sheath box
Chicago, St. Paul, Minn. & Omaha	200	Gondola—drop bottom
Delaware & Hudson	500	Single sheath box
Delaware & Hudson	1,000	Hopper
Delaware, Lackawanna & Western	500	Gondola—low side
Delaware, Lackawanna & Western	700	Hopper
Delaware, Lackawanna & Western	500	Gondola—drop bottom
Duluth, South Shore & Atlantic	200	Double sheath box
Duluth, South Shore & Atlantic	300	Gondola—drop bottom
Detroit, Toledo & Ironton	500	Double sheath box
Elgin, Joliet & Eastern	300	Single sheath box
Erie	1,000	Single sheath box
Erie	700	Hopper
Erie	800	Gondola—drop bottom
El Paso & Northwestern	500	Double sheath box
El Paso & Northwestern	200	Gondola—drop bottom
Florida East Coast	500	Single sheath box
Georgia	500	Single sheath box
Georgia	300	Gondola—drop bottom
Great Northern	1,500	Double sheath box
Hocking Valley	500	Gondola—drop bottom
Illinois Central	2,000	Double sheath box
Illinois Central	100	Gondola—drop bottom
Kansas City Southern	500	Single sheath box
Long Island	500	Single sheath box
Louisville & Nashville	2,000	Hopper
Louisville & Nashville	2,000	Gondola—drop bottom
Lehigh Valley	1,000	Single sheath box
Lehigh Valley	500	Gondola—low side
Lehigh Valley	1,300	Hopper
Lehigh Valley	500	Gondola—drop bottom
Michigan Central	1,000	Single sheath box
Michigan Central	300	Gondola—drop bottom
Maine Central	500	Single sheath box
Minneapolis & St. Louis	300	Double sheath box
Missouri Pacific	1,000	Single sheath box
Missouri Pacific	1,000	Gondola—drop bottom
(Including St. L., I. M. & S.)		
Northern Pacific	1,000	Double sheath box
Norfolk & Western	300	Single sheath box
Norfolk & Western	200	Gondola—drop bottom
Norfolk Southern	200	Single sheath box
Northern Pacific	100	Double sheath box

New York, Chicago & St. Louis	500	Double sheath box
New York Central	2,000	Single sheath box
New York Central	500	Gondola—low side
New York Central	1,000	Hopper
New York Central	1,000	Gondola—drop bottom
New York, New Haven & Hartford	1,500	Hopper
Pennsylvania	2,000	Single sheath box
Pennsylvania	300	Gondola—low side
Pennsylvania	2,000	Hopper
Pennsylvania Lines West	2,000	Single sheath box
Pennsylvania Lines West	1,000	Gondola—low side
Pennsylvania Lines West	2,500	Hopper
Pennsylvania Lines West	2,000	Gondola—drop bottom
(Including L. S. & M. S. and C. I. & S.)		
Pere Marquette	500	Single sheath box
Pere Marquette	500	Gondola—drop bottom
Philadelphia & Reading	1,000	Single sheath box
Philadelphia & Reading	500	Gondola—low side
Philadelphia & Reading	2,000	Hopper
Pittsburgh & Lake Erie	500	Single sheath box
Pittsburgh & Lake Erie	500	Gondola—low side
Richmond, Fredericksburg & Potomac	500	Single sheath box
Seaboard Air Line	500	Single sheath box
Southern Railway	2,000	Single sheath box
(Including C. N. O. & T. P., A. G. S., N. O. & N., Harriman & N. E., Nor. Ala.)		
Southern Pacific	2,000	Double sheath box
Spokane, Portland & Seattle	300	Double sheath box
St. Louis-San Francisco	1,500	Double sheath box
St. Louis-San Francisco	1,000	Gondola—drop bottom
Toledo & Ohio Central	250	Double sheath box
Toledo & Ohio Central	1,000	Hopper
Texas & Pacific	500	Double sheath box
Toledo, St. Louis & Western	500	Double sheath box
Toledo, St. Louis & Western	750	Hopper
Union Pacific System	1,000	Double sheath box
(Includes O. S. L. and O. W. R. & N.)		
Wabash	1,500	Double sheath box
Wabash	1,000	Gondola—drop bottom
Wheeling & Lake Erie	1,000	Hopper
Western Maryland	300	Single sheath box
Total	100,000	

SUMMARY

Single sheath box	25,000
Double sheath box	25,000
Gondola—low side	5,000
Gondola—drop bottom	20,000
Hopper	25,000
Total	100,000

SAVE FUEL BY SAVING AIR

A committee composed of 27 members of the Air Brake Association met in Chicago, July 31, and drew up a number of recommendations for reducing train pipe leakage and thereby effecting a material saving in locomotive fuel consumption. These recommendations were presented at a meeting of railroad officers convened by Eugene McAuliffe, manager of fuel conservation section of the Railroad Administration, in Chicago, the following day.

The recommendations are as follows:

Realizing our country's present urgent need of fuel saving to the highest degree, and being actuated by a patriotic desire to be genuinely useful in its particular way, the Air Brake Association, through its president, F. J. Barry, has proffered its active assistance to the Railroad Administration's division on fuel conservation, of which you have been made the official head. Your acceptance of this assistance resulted in the convening of a special committee of supervising air brake men from 24 of the largest railroads of the United States. This committee's deliberations resulted in the consensus of opinion that its greatest and most needful help in fuel saving could be rendered through a materially decreased leakage in brake pipes on freight trains, which, according to careful expert estimate, is now the cause of a wastage of more than 6,000,000 tons of coal annually. This wastage can be materially cut down, in the opinion of the Air Brake Association Committee, quickly and with little additional cost, if the following recommendations be diligently and faithfully followed by the railroads and the government alike:

(1) In switching cars in hump yard service, hand brakes must be known to be in operative condition before dropping over the hump. Each cut should be ridden home and not be allowed to hit cars on make-up track at a speed exceeding three miles per hour, as excessive shocks result in loosened brake pipe and cylinder connections with attendant leakage

at joints. Same conditions apply to general yard switching, and similar care should be exercised.

(2) When hose are uncoupled, they must be separated by hand and not pulled apart. Pulling hose apart is not only the most prolific cause of brake pipe leakage, but the damage annually due to train parting, account of hose blowing off nipples, also bursting, due to fiber stress, results in damage running into thousands of dollars. Angle cocks first must be closed if brake pipe is charged.

(3) Ample time must be allowed properly to inspect the air brakes and place them in good working order before leaving terminals.

(4) Freight terminals where conditions and business handled justifies, should be provided with a yard testing plant, piped to reach all outbound trains. At all freight houses, loading sheds, team tracks and other places where cars in quantity are spotted for any purpose long enough to make repairs and test brakes, air should be provided to do such work.

(5) On shop and repair tracks provided with air, brakes should be cleaned and tested in accordance with M. C. B. rules and instructions. Weather permitting, hose and pipe connections shall be given soap-suds tests. Hose showing porosity shall be removed and all leaks eliminated before car is returned to service.

(6) Freight trains on arrival at terminals where inspectors are stationed to make immediate brake inspection and repairs, shall have slack stretched and left with brakes fully applied.

(7) Brake pipe leakage on outbound freight trains shall not exceed eight pounds per minute and preferably should not exceed five pounds per minute following a fifteen-pound service reduction from standard brake pipe pressure, with brake valve in lap position.

(8) A suitable pipe wrench should be furnished each caboose to enable trainmen to remove and replace hose and to tighten up leaks developing enroute. Instructions directing its use should be posted in each caboose.

(9) A rule should be put into effect that trainmen must apply an M. C. B. standard air brake defect card in cases where defects develop enroute, or for brakes cut out by them, defect to be checked off on back of card.

(10) Air compressor strainers must be known to be free of foreign matter before each trip and removed for cleaning if necessary. Steam pipe to compressor to be lagged outside of cal or jacket.

(11) Special effort must be made to reduce the leakage of the various air-operated devices on locomotives.

(12) In mounting air hose, the coupling should be gaged with an M. C. B. standard gage, and the couplings and coupling packing rings known to be standard.

(13) Special attention should be given to maintaining brake pipe, brake cylinder, reservoir, retaining valves and pipe secure to car.

(14) The importance of competent air brake supervision successfully to cope with existing conditions cannot be over estimated.

(15) In the recommendations submitted it is not the intent in any way to abrogate existing instructions or rules that are now in force that are more stringent than those recommended, as these recommendations are intended to represent maximum conditions.

The letter was signed by the members of the committee: L. P. Stricker, I. C. chairman; L. H. Albers, N. Y. C.; M. S. Belk, Sou. Ry. Lines; R. C. Burns, Penn. R.R.; H. A. Clark, Soo Line; H. A. Flynn, D. & H.; M. E. Hamilton, St. L.-S. F.; C. M. Kidd, N. & W.; Mark Purcell, N. P.; H. L. Sandbas, C. R. R. of N. E.; C. Terwilliger, N. Y., N. H. & H.; Robert Wark, No. Pac.; W. W. White, M. C.; L. S. Ayer, Sou. Pac.; I. A. Burke, Santa Fe; T. L. Burton, N. Y. C.; T. W. Dow, Erie; H. A. Glick, Bangor &

Aroostook; E. Hartenstein, C. & A.; P. J. Langan, D. L. & W.; R. M. Long, P. & L. E.; C. H. Rawlings, D. & R. G.; H. S. Walton, Boston & Albany; C. H. Weaver, N. Y. C.; Geo. H. Wood, Santa Fe; H. F. Wood, Boston & Maine; F. M. Nellis, secretary.

SETTLEMENT FOR DESTROYED CARS

BY A. M. ORR

It seems to me that the subject of the settlement for destroyed cars is worthy of renewed discussion. To present the subject in a new light, I will refer to the case of two cars, steel underframe box, of the same series, built in 1910. One of these cars had its superstructure burnt off on a foreign road in 1917, the other was reported destroyed by another foreign line in the same month. The road on which the superstructure was burnt off sent the car home as a flat car, it being in such good shape that intermediate roads did not realize that it had been in trouble. It came home in the usual way in ordinary service as it would have done had it been a flat car when first built. A defect card for "Body above sills destroyed by fire" was furnished the owner and the superstructure was rebuilt. The cost of rebuilding this car was greater than what the other road paid for the destroyed car! Why was this absurdity possible?

It was possible because the practice of the M. C. B. Association in the case of destroyed cars is based upon the answer to the question, "What did the car cost when new and how much depreciation has occurred, when calculated upon an accounting basis?" while in the case of repairs to cars the practice is based upon the answer to the question "What will it cost to replace the defective parts?" It seems to me that the latter method should be used also in the case of settling for cars destroyed, and I give below my reasons for taking this position.

A railroad being by force of events a continuing concern in 99 per cent of all cases, any car going out of service will have to be replaced as soon as possible in order to keep up with the continuously increasing demands for transportation service. When the car is destroyed on a foreign line, the expense to the owner is not the adjustment of the books of the accounting department, but the cost of replacing the car. As a matter of detail the number of the cars destroyed may be left vacant and replacement cars bought under other numbers, but the total of cars owned by a road never for any length of time shows a constant decrease.

If this position is correct, and I can not see how it can be successfully assailed, then remains the question, "How may the cost of replacement be determined?"

We should first consider the question of depreciation. This is a subject which has been handled from the beginning in accordance with the accounting principle which considers "depreciation" synonymous with "obsolescence," a deterioration which proceeds practically uniformly from the time a structure is built until conditions are so changed that the structure will no longer serve a useful purpose. This does not seem to be a proper method in the case of a car. As a matter of pure fact, the car depreciates in value to a great extent immediately upon its being put into service. It would probably be proper to say that all the overhead charges and car companies' profits should be taken away from the value of the car at the end of the first year, thus bringing the value down to the cost of replacing it in the shops of the owner, where there would be no profits to be considered and no actual increase in "shop overhead expense" on account of the rebuilding of one car.

Further, for about five years after its being put into service, a car is of more value than it is in later years because of the fact that for about that length of time it does not visit the repair tracks often, unless on account of a wreck, and is

therefore available for a longer period during the year for revenue service. Therefore, it would be proper to depreciate the value of the car to the owner further during that five years. It might be suggested that the car might be considered as depreciating 25 per cent the first year and $2\frac{1}{2}$ each year for the four ensuing years, a total depreciation of 35 per cent, leaving the car at a value of 65 per cent of its original value from thence on.

You will note that distinction between this method and the present method lies in the fact that the proposed method considers two conditions: First—the scrap value of the car, perhaps 25 per cent of its value new under normal conditions. Second—a value which is like the “good will” of a business house, a factor of value fully recognized by law, the value of the car as a “going concern.” In other words, any cars which will carry loads are immeasurably superior to cars which will not carry loads, and the owner should be recompensed for the loss of the ability to get the car home and use it, as well as for the scrap held in the hands of the destroying road.

In the second case, we have to consider the method of arriving at the base value of the car. The answer to this problem lies in the present rules, for the M. C. B. Association has for many years provided for the settlement of claims for destroyed cars on the basis of the price per pound which is set in M. C. B. Rule 112, a price which can be changed yearly if the Association finds it necessary on account of changed conditions. What no one has done so far apparently is to consider other classes of cars to see whether a pound price could be applied to cars in general. I have done so as far as limited opportunity permits and have found that there is less variation between the price per pound of different classes of cars built in the same year than there is in the price per pound of cars of the same class purchased in different years. The refrigerator costs more than the box car of similar construction but it weighs more. The gondola costs more than the flat, but weighs more. The price of the steel gondola will vary more between one year and another than will the gondola and the box car (per pound) in the same year.

Under the present system we have a very complicated method of arriving at the base cost of a car, a method which some seem to wish to make more complicated each year. The system, like every other system which concerns a continuing proposition as the railroads on as large a scale as the railroads of the United States, will in the long run bring results which will be perfectly fair to all concerned. As a by-product the present system makes it necessary to have a force of clerks who can keep track of the complicated methods of the rules and another force of clerks who keep track of the values of the cars built after 1914 in order to furnish the information at any time on any car. Not much labor perhaps on any one road, but considerable when all roads are concerned.

If the M. C. B. Rules would be changed to make the base price of all cars what the base price of steel cars now is, the price per pound at the weight of the car at its last weighing, there would be a system of settlement which would not require any complicated method or learned clerks. Just two facts, “How much did the car weigh?” “How old was the car?”

If the rules would adopt the method suggested on depreciation in place of the present one based on “obsolescence,” and would set a price per pound which would represent the value of the average car, the case would still be simpler. Then there would be but one question, “What is the weight stencilled on the car?”

In this discussion I have neglected the allowances for friction draft gear, wrought steel wheels, steel center sills, metal body bolsters, and so on. These extra allowances were al-

lowed by the Association to foster the equipment of cars with things which would make the cars better. There would be no objections from the accounting standpoint were that system to be continued, although it would keep part of the present complications of billing still in force. We must stand for some complication if a useful purpose is subserved.

To sum up, it seems that the present method is wrong in that it is based upon a system of accounting which considers the obsolescence of equipment with a purpose of accumulating a surplus to protect the stockholders when the equipment gets out of date, instead of considering that the car has a “service value” so long as it will run. For example, there are two cars in service today, just as valuable as the day they were built, which were the first steel cars put into service. Their actual scrap value is in excess of the 40 per cent of the original value which the rules will permit to be charged if they are destroyed on foreign lines.

Therefore, these cars, now 22 years old, are just as valuable from the Transportation standpoint as if they were only 2 years old. Yet the road which destroys them can dismantle the scrap and sell it and pay the owner under the M. C. B. Rules and have an actual profit.

The price per pound of all classes of cars is near enough alike that one price could be established which would be close to the average value of any particular car. And that price should be the price of replacement, not the cost when new or an arbitrary price based upon conditions when the car was built.

These changes would have been proper years ago, they are especially desirable now when all our energies are necessary to the successful carrying on of a great war.

THE DESIGN OF OFFSET BEAMS

BY VICTOR M. SUMMA
Engineering Examiner, American Brake Company

In designing it is often necessary to offset certain members to secure the required clearance. This introduces stresses which are not found in straight members. Where the offsets are large the section at the bends is sometimes increased, however, many cases can be found where the strength has been greatly reduced without a corresponding increase in the section being made. Even where the section is increased it is often done unscientifically. In view of the apparent lack of knowledge of the proper methods of

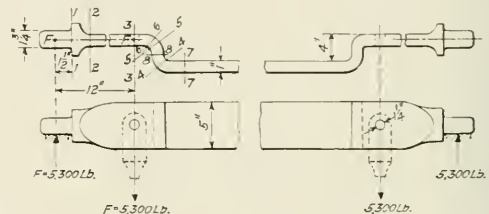

Fig. 1

designing offset parts, a discussion of the subject should be of value.

The mistake most often made in calculations of this kind is to use the formulae:

$$M_e = \frac{1}{2} m + \frac{1}{2} \sqrt{m^2 - r^2} \quad \text{and}$$

$$R_e = m - \sqrt{m^2 - r^2}$$

Where M_e = equivalent bending moment due to combined bending and twisting stresses.

R_e = equivalent twisting moment due to combined bending and twisting stresses.

m = bending moment due to bending stresses alone.

r = twisting moment due to twisting stresses alone.

These formulae apply to circular sections only. For non-circular sections it is necessary to use the general equations

$$T = \frac{1}{2} p - \sqrt{v^2 + \frac{1}{4} p^2} \dots \dots \dots (1)$$

$$S = \sqrt{v^2 + \frac{1}{4} p^2} \dots \dots \dots (2)$$

Where T = maximum tensile or compressive unit stress
 S = maximum shearing unit stress
 p = applied tensile unit stress
 v = applied shearing unit stress

These expressions can be applied regardless of the shape of the section or the manner in which the stresses are pro-

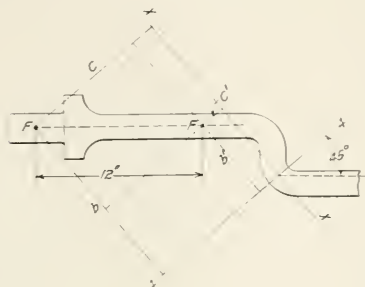

Fig. 2

duced, as the relations hold good for all cases where the tensile or compressive stress, *p*, and the shearing stress, *v*, act at right angles to each other.

For purposes of illustration the design of an offset brake beam will be considered. The beam shown in Fig. 1 failed in service, so an investigation of the stresses in various sections will be of interest. The two pull rods, each of which transmits a maximum force of 5,300 lb., are attached 12 in. from the centers of the trunnions which also bear a pressure of 5,300 lb. The center portion of the beam is of a rectangular section 1-in. by 5-in. and has a 4-in. offset. Sections (1-1), (2-2) and (3-3) are subjected to plain bending and the unit stresses at these points are readily ascertained by the usual method, but sections (4-4), (5-5) and (6-6) have to resist shearing stresses due to the torsional moment besides the tensile or compressive stresses set up by the bending moment, and the stresses in these sections are not so easy to determine.

The diagram in Fig. 2 shows the forces acting on section 4-4, which make an angle of 45 deg. with the horizontal. The lines x-x and 4-4 represent the axes respectively of the

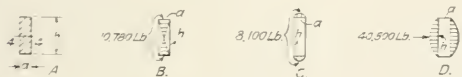

Fig. 3

polar modulus or modulus of the section for torsion *Z_p*, and the rectangular modulus or modulus for bending *Z*. The two forces *F* are equal and act in opposite directions, both being in lines perpendicular to the plane of the paper. Let *b* and *b'* represent the distances of these forces from the axis 4-4 and *c* and *c'* their distances from the axis x-x. Let *M* be the bending moment and *R* the twisting moment due to these forces.

$$\text{Then } M = Fb - Fb' = F(bb') = F \times 12 \times \sin 45^\circ$$

$$R = Fc - Fc' = F(cc') = F \times 12 \times \cos 45^\circ$$

Therefore $M = R = 3,300 \times 12 \times .707 = 45,000$ inch pounds. Also $M = \frac{1}{2} pZ$, where *p* = maximum unit stress in tension or compression, $Z = \frac{bh^3}{6}$ = modulus of section in tension or compression (for rectangular section $Z = \frac{bh^3}{6}$ see Fig. 3a)

$$\frac{M}{Z} = \frac{45,000 \times 6}{1 \times 5^3} = 10,800 \text{ lb. per sq. in.}$$

The tensile or compression stresses are of course greatest at the edges and decrease toward the neutral axis where they are zero. The distribution of stresses is shown in Fig.

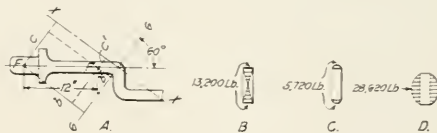

Fig. 4

3b, the width of the shaded portion indicating the magnitude of the unit stresses.

To find the maximum shearing stresses use the formula:

$$R = v Z_p \text{ or } v = \frac{R}{Z_p}$$

Where *v* = unit shearing stress
Z_p = modulus of section in shear (for rectangular sections $Z_p = \frac{2}{9} a^2 b \text{ or } \frac{2}{9} a b^2$)

$$v = \frac{R}{Z_p} = \frac{45,000 \times 9}{\frac{2}{9} \times 1 \times 5^3} = 8,100 \text{ lb. per sq. in.}$$

$$= \frac{45,000 \times 9}{2 \times 5 \times 1^2} = 40,500 \text{ lb. per sq. in.}$$

On any side of a rectangle the shearing stress is greatest at the middle and varies approximately as the ordinates of a parabola toward each corner where it becomes zero. The

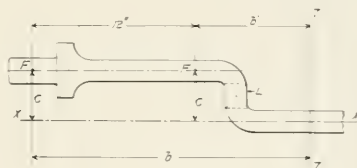

Fig. 5

stress at the middle of the broad side is greater than at the middle of the short side (see Fig. 3c and 3d).

It will be seen that the maximum stresses are 40,500 lb. per sq. in. in simple shear occurring at the middle of side *h*, and those resulting from the combination of 10,780 lb. per sq. in. tension or compression and 8,100 lb. per sq. in. shear at the middle of the shorter side, *a*. As the lines of action of these stresses are at right angles, we can find the resultant forces by using formulae 1 and 2 given above.

$$\text{From (1) } T = \frac{10,800}{2} + \sqrt{8,100^2 + \frac{10,800^2}{4}} = 15,140 \text{ lb. per sq. in. in}$$

tension or compression.

$$(2) S = 9,740 \text{ lb. per sq. in. in shear.}$$

These may be considered the greatest combined stresses in the section. The shearing stresses at the center of the

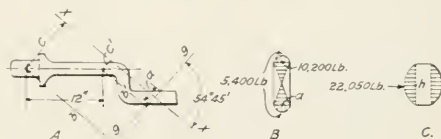

Fig. 6

long side may be exceeded by the combined stresses a short distance on either side of the center, but for all practical purposes these stresses can be neglected.

It is evident that since the angle which the section 5-5

makes with a horizontal plane is 45 deg., the stresses just found for section 4-4 will apply to it also, as the moments will be the same as those about section 4-4.

The next section to be considered is section 6-6 which makes an angle of 60 deg. with the horizontal. The stresses are shown in the diagram, Fig. 4a. In this case,

$$\begin{aligned}
 M &= F (b \cdot b') = F \times 12 \times \sin 60^\circ \\
 &= 5,300 \times 12 \times 0.866 \\
 &= 55,000 \text{ in. lb.} \\
 R &= F (c \cdot c') = F \times 12 \times \cos 60^\circ \\
 &= 5,300 \times 12 \times 0.5 \\
 &= 31,800 \text{ in. lb.} \\
 p &= \frac{55,000 \times 6}{1 \times 5^2} = 13,200 \text{ lb. per sq. in.} \\
 v &= \frac{31,800 \times 9}{2 \times 1 \times 5^2} = 5,720 \text{ lb. per sq. in.} \quad \text{or} \\
 v &= \frac{2 \times 1 \times 5^2}{31,800 \times 9} = 28,620 \text{ lb. per sq. in.} \\
 v &= \frac{2 \times 5 \times 1^2}{31,800 \times 9} \quad (\text{See Fig. 4, b, c and d})
 \end{aligned}$$

It is necessary to find the resultant of the tensile or com-

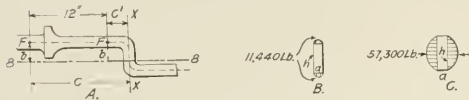

Fig. 7

pressive and shearing stresses at the middle of the short side, as in the section 4-4

$$\begin{aligned}
 T &= \frac{13,200}{2} + \sqrt{\frac{5,720^2}{4} + \frac{13,200^2}{4}} = 15,350 \text{ lb. per sq. in., in tension or} \\
 S &= 8,750 \text{ lb. per sq. in. in shear.}
 \end{aligned}$$

The next section to be investigated is 7-7. (see Fig. 5.) In this case

$$\begin{aligned}
 M &= F (b \cdot b') = F \times 12 = 5,700 \times 12 = 63,600 \text{ in. lb.} \\
 p &= \frac{63,600 \times 6}{1 \times 5^2} = 15,150 \text{ lb. per sq. in.} \\
 R &= F (c \cdot c') = 0
 \end{aligned}$$

It will be seen that in section 7-7, normal to the axis x-x, there are only bending stresses. The equations for *M* and *R* show not only that these stresses are constant between the two middle bends, but also that they are not greater than the stresses in a straight beam, provided that the depth of the offset is not enough to cause any appreciable distortion of the beam, due to the torsional stresses in the vertical portion, *L*, marked with a dotted cross in Fig. 5.

Due to the method of loading, it is possible that some sections like 9-9 (see Fig. 6a) making an angle with the



Fig. 8

horizontal, may develop shearing stresses greater than the section can withstand. It is evident that the bending stresses will not be greater than in section 7-7. The point at which the shearing stresses are greatest can be determined from the general equation for these stresses by differential calculus or by making complete calculations for sections at various angles. In this case it is found that the maximum shearing stress occurs in a section making an angle of 54 deg. 45 min. with the horizontal axis. The shearing unit stress at the middle of the long side of the section is 22,050 lb. per sq. in. and at the middle of the short side 5,400 lb. per sq. in. The maximum combined tensile and shearing unit stresses at the center of the short side of the section are

12,500 lb. per sq. in. and 12,250 lb. per sq. in. respectively. As the shearing stresses should not exceed 20,000 lb. per sq. in. the section should be increased to say $1\frac{1}{8}$ in. by 5 in.

We will now consider section 8-8 (see Fig. 7a). Here

$$\begin{aligned}
 M &= F (b \cdot b') = 0 \\
 R &= F (c \cdot c') = 5,300 \times 12 = 63,600 \text{ in. lb.}
 \end{aligned}$$

In other words this is just the converse of section 7-7, as in this section there are only torsional stresses. The unit stresses are as follows:

$$\begin{aligned}
 v &= \frac{63,600 \times 9}{2 \times 1 \times 5^2} = 11,440 \text{ lb. per sq. in.} \\
 v &= \frac{63,600 \times 9}{2 \times 5 \times 1^2} = 57,300 \text{ lb. per sq. in.}
 \end{aligned}$$

The values of *M* and *R* will not change though section 8-8 is taken at any point between n-n and m-m (see Fig. 8a) and since the section between these points is uniform, the unit stresses must be the same. Of course a shearing stress of 57,300 lb. per sq. in. is far beyond the safe limits, as the ultimate shearing strength of wrought iron is only about 40,000 lb. per sq. in. Failure was therefore bound to occur in the vertical section of the beam.

Assuming that the stresses should not exceed 20,000 lb. per sq. in. in either tension or shear, the next problem is to find the dimension of side *a*, at the sections 4-4, 6-6 and 8-8 required to limit the stresses to this value, the width remaining 5-in. Let *x*₁, *x*₂ and *x*₃ be the required

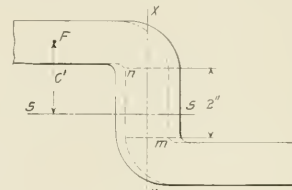

Fig. 9

thicknesses at these sections. Referring to the calculations for the stresses in section 4-4 we find

$$v = \frac{45,000 \times 9}{2 \times 5 \times 1^2} = 40,500 \text{ lb. per sq. in.}$$

Substituting the required value of 20,000 for *v* and *x*₁ for *L*, we have,

$$\begin{aligned}
 20,000 &= \frac{45,000 \times 9}{2 \times 5 \times x^2} \\
 \text{or } x &= \sqrt{\frac{45,000 \times 9}{2 \times 5 \times 20,000}} \\
 x_1 &= 1.42 \text{ or } 1\frac{1}{7} \frac{1}{16} \text{ in.}
 \end{aligned}$$

Similarly

$$\begin{aligned}
 x_2 &= \sqrt{\frac{31,800 \times 9}{2 \times 5 \times 20,000}} = 1.2 \text{ or } 1\frac{1}{8} \frac{1}{16} \text{ in.} \\
 x_3 &= \sqrt{\frac{63,000 \times 9}{2 \times 5 \times 20,000}} = 1.68 \text{ or } 1\frac{11}{16} \frac{1}{16} \text{ in.}
 \end{aligned}$$

The shape of the section with these required dimensions is shown in Fig. 8b.

It is necessary to ascertain the angular deflection of the vertical portion of the beam, (m-n in Fig. 9) in order to determine whether the beams will be unduly distorted under the action of the maximum stresses. To find the angular deflection, use the formula

$$\phi = \frac{205 M_t l (a^2 + F)}{a^3 l^3 G}$$

Where
 ϕ = angle of deflection in degrees.
*M*_t = twisting moment, in inch-pounds.
l = length of section subjected to twisting moment, in inches.

$$G = \frac{W}{A \times L} \times \frac{1}{\text{elasticity for shear, generally taken as } 10,500,000 \text{ for wrought iron}}$$

$$= \frac{205 \times 5300 \times 12 \times 2 \times (1.68^2 + 59)}{726,000,000} = \frac{1,165 \text{ deg.}}{6,210,000,000} = \frac{1.68^2 \times 5^2 \times 10,500,000}{6,210,000,000}$$

Evidently this slight angular deflection will be of no consequence, and the beam as designed has ample stiffness.

RAILROAD ADMINISTRATION'S PAINT ORDERS

The car builders have been authorized by the Central Advisory Purchasing Committee to purchase all the painting materials (except wood preservative) for painting the cars they are to build for the U. S. Railroad Administration, at prices not to exceed the following:

- Reinforced Red Lead Semi-paste Paint (Spec. R-810), \$2.40 per gallon, f. o. b. factory.
- Dark Red Oxide Semi-paste Paint (Spec. R-812), \$1.40 per gallon, f. o. b. factory.
- Black Semi-paste Paint (Spec. R-811), \$1.65 per gallon, f. o. b. factory.
- Stenciled Black Paste Paint, \$0.10 per pound, f. o. b. factory.
- Stenciled White Paste Paint, \$0.11 per pound, f. o. b. factory.
- Thinning Mixture (Spec. R-822-A), \$0.83 per gallon, f. o. b. factory.

A list of the paint manufacturers agreeing to furnish paint at these prices may be had on application to the committee.

The builders are expected to purchase the paint at a price lower than the maximum figures named, if they can, taking into consideration sureness of supply, shortest haul and least congested routes. They are also advised that by spreading deliveries over an extended period they may also be able to obtain lower prices. Copies of all orders must be sent to the Inspection and Test Section and to the Procurement Section.

The above instructions to the carbuilders are of particular interest because they indicate in great measure the policy that is being followed out by the Procurement Section to allow the carbuilders to use their own organizations and established practices in the matter of purchasing and procuring material, thereby securing the advantages of the familiarity which these departments have with the purchasing of supplies.

A copy of the specifications for reinforced red lead semi-paste paint (R-810) and black semi-paste paint (R-811) are given below:

REINFORCED RED-LEAD SEMI-PASTE PAINT Locomotives and Cars R-810

1. *General Specifications.*—General specifications for paint and painting materials issued by the Railroad Administration in effect at date of opening of bids, shall form part of these specifications.

2. *Grinding Proportions.*—The grinding proportions shall be:
Pigment, 82 per cent.
Liquid, 18 per cent.

The pigment portion shall consist of:
Red lead, not less than 65 per cent.
The remainder shall be silicious matter, such as aluminum silicate, magnesium silicate, silica, or a mixture thereof.

The red lead shall contain not less than 85 per cent true red lead (Pb₃O₄), the remainder to be litharge (PbO).

The liquid portion shall consist of raw linseed oil.

3. *Special Requirements.* The semi-paste paint shall weigh not less than 22 pounds per gallon. When mixed with the thinning mixture in the proportion of 1 volume of semi-paste to 11 volumes of Standard thinning mixture, the resulting mixture applied to a smooth metal surface shall dry in 10 hours with an oil gloss.

BLACK SEMI PASTE PAINT Locomotive and Cars R-811

1. *General Specifications.*—General specifications for paint and painting materials issued by the Railroad Administration, in effect at date of opening of bids, shall form part of these specifications.

2. *Grinding Proportions.*—The grinding proportions shall be:
Pigment, 50 per cent.
Liquid, 50 per cent.

The pigment portion shall consist of:
Black, not less than 20 per cent.
The remainder shall be shale black, aluminum silicate, magnesium silicate, silica, or a mixture thereof.

The black shall be of such quality as to produce the standard color and shall not contain more than 2 per cent of ash.

The liquid portion shall consist of raw linseed oil.

3. *Special Requirements.* The semi-paste paint shall weigh not less than 22 pounds per gallon. When mixed with the thinning mixture in the proportion of 1 volume of the semi-paste to 11 volumes of the Standard thinning mixture, the resulting mixture applied to a smooth metal surface shall dry in 10 hours with an oil gloss.

PAINTING AND LETTERING FREIGHT CARS

The regional director of the eastern region has issued the

following instructions governing painting and preservation of identity marking on freight car equipment, to become immediately effective:

1. The preservation of freight car equipment of all railroads under Federal control will be maintained by necessary repainting and restenciling. When paint on freight equipment cars has become perished to the extent of permitting the steel to rust and deteriorate, or the wood to become exposed to the weather, they should be repainted. The car body (including roof) should be entirely repainted if, for any cause, it is found necessary to paint one-third or more of the car. Before applying paint to steel, it should be scraped and cleaned off with wire brush; wood parts should be scraped so as to clean off all blisters and loose paint, including removal of protruding nails and tacks.

2. The station marking showing where car was last reweighed should not be changed unless the car is reweighed.

3. When repainting freight equipment cars, two coats will be applied to all new parts and old parts of body which have been reworked causing removal of paint. One coat will be applied to parts where old paint is in good condition. Should the old paint be found in such condition requiring two coats, they may be applied.

4. The stenciled letters and numbers on all freight equipment cars will be maintained and identity kept bright. When the lettering or numbering is found in bad condition, renew the identity by either repainting the car or by applying new stenciled letters and numbers. In selecting cars for this purpose, preference should be given those on which the marking and painting is in the poorest condition.

5. If there is not sufficient paint on car to properly retain the new stenciling, and condition of car does not justify entire repainting, one coat should be applied as a panel back of the stenciling, so that the paint used in applying the numbers and letters will hold; otherwise, the marking applied will soon become illegible and make it necessary to again apply the identity marking within a short period.

6. Detention of equipment from service for painting should be avoided when possible. A great deal of this work can be done to open cars in transportation yards when under load in storage.

WHY DON'T DADDY COME?*

BY O. D. BOYLE
Yard Brakeman, Baltimore & Ohio, Washington, D. C.

When the Baltimore & Ohio organized its first safety committees several years ago, I had the honor of representing the employees in train service at this terminal. I entered the work with an enthusiasm that grew into elation when the succeeding monthly charts showed a surprisingly large reduction in the number of preventable accidents. Yet, while I was preaching Safety to my fellows, I was not practicing it myself—I could not resist the temptation to take a chance occasionally. As I look back I can see that my work for Safety was a hollow proposition; merely a question of making a "good record."

But a new epoch in my "Safety First" education was reached when God sent us Helen. She has been with us almost three years now, so, of course, by this time we are very well acquainted. She is not yet old enough to understand the general scheme of life, but she is fully conscious of the fact that I must leave her every morning "cause your train's awaitin' for you," and that I should come back to her "some-time after the sun's gone to bed." And what a time for her when "Daddy" does come home! I have just rung the bell—I can't see her yet, but I can hear her joyous cry, "Daddy's home! daddy's home!" and a rush of eager feet across the room. Oh yes, I see her now running through the hall—

*Reprinted from the Baltimore & Ohio Employees' Magazine.

mamma opens the door—a jump into my ready arms—a squeeze—a smack—"So glad you've come, daddy!"—and then an evening of joy.

She is not yet old enough to understand about derailments, engine failures, congested yards or a thousand other things that sometimes occur on the best regulated railroads, so that when I happen to be the "goat," it is the cause of many troubled moments to the precious little mind and the source of many anxious queries to her mother—"Why don't daddy come?"

Ah! "Why don't daddy come?" Suppose daddy never comes! Suppose the anxious waiting moments are turned into an unbroken vigil of days—months—years! Could a million dollars' insurance erase the yearning of the little troubled heart? Could all of the great lawyers in this land make her understand when, with her anxious face turned up to meet the tear-dimmed eyes of her mother, she asks, "Why don't daddy come?"

No! That's why I stopped going between moving cars at the last moment, to adjust the knuckle. That's why I stopped kicking couplers. That's why I stand on the outside of the rail when boarding my engine. That's why I am extra careful in walking over the top of my train in bad weather. That's why I inspect my train at every opportunity. That's why I work with an absolute conviction that if I don't go home to Helen tonight it will be because of the will of God or the carelessness of you, fellow-worker.

To the will of God I can only say, "Be merciful. Thy will be done."

But of you fellow-worker, I ask "Would you rob my child?" Certainly you would not take her candy, her doll, her house or her little iron bank. Assuredly not! Yet if you did, they could be replaced.

Again, I ask you, "Would you strike my child?" No! Yet if you did, it would soon be forgotten.

Now, I ask you, "Would you rob her of her daddy? Would you strike her little heart a blow that would never be forgotten?"

Then the next time you see a loose handhold, chalk it, so that I can notice it when grabbing for it; the next time you see an obstruction near the track, remove it, so that I won't

fall over it when switching; if you see a switch point which does not fit tight report it so that my train won't pick it open; if you find a switch light out, fix it so as to protect my train when I come along; if your train stops, go back to flag just a little bit further, so as to be doubly sure my train won't be wrecked; if you find a bad section of track, repair it today, so that my train won't spread the rails when it reaches it; if you can remedy any unsafe condition or practice and make my occupation a little less hazardous, do it. I do not ask it for myself. I can stand the shock of losing a limb and, with God's help, I do not fear death. But—

Helen will be waiting for me tonight, and tomorrow night and every night and I don't want her unanswered when she anxiously asks—"Why don't daddy come?"

SOME OF THE DANGEROUS PRACTICES WHICH PREVENT DADDY GETTING HOME SAFELY

When we leave cars too close to a switch to clear a man on the side of a car on the adjoining track.

When we leave drawbars, material and other movable obstructions too close to the track.

When we leave boards with nails sticking up for ourselves or some one else to step on.

When we fail to put out a blue flag when under cars repairing or inspecting them.

When we refuse to wear goggles.

When we use defective and burred tools.

When we kick drawbars over just as cars are coming together.

When we throw away guards on emery wheels and gearing of machines.

When we do not keep a lookout for moving cars or engines while working about trains.

When we move cars on loading tracks without first requiring occupants to get out.

When we find a loose grab iron, ladder rung or a bad order coupler and fail to fasten a red tag to it so that the next man will be warned and the necessary repairs made.

Why not cut out these dangerous practices and stop working for the doctor and undertaker and keep ourselves whole and sound for the benefit of the wife and kids?



Copyright by Committee on Public Information. Supplied by International Film Service

Camouflaged Freight Cars for Carrying Munitions to the Front in France



SHOP PRACTICE



AIR HAMMER ATTACHMENT

BY J. S. BREYER

Master Mechanic, Southern Railway, Charleston, S. C.

The air hammer attachment shown in the illustration is for use in splitting nuts on grab irons and ladders when dismantling cars for heavy repairs.

The device consists of a piece of 1-in. square iron forged at one end and in the shape of a yoke around a hammer, and at the other end bent at 90 deg. as indicated. Near the end of the barrel of the air hammer there is a collar which fits

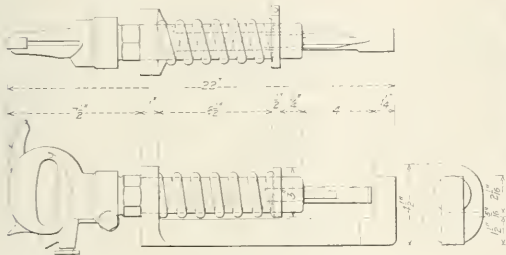

Nut Splitting Attachment for Thor Hammer

into a groove $\frac{1}{2}$ -in. wide by $\frac{1}{8}$ -in. deep, and is the stop for a $\frac{3}{16}$ -in. coil spring. The purpose of this spring is to hold the hammer and chisel against the yoke, and as the yoke fits closely around the barrel of the hammer, there is no danger of the chisel shooting out and causing an accident.

In operation, the end of the yoke, which is bent to an angle of 90 deg., is hooked around one side of the nut and the chisel brought to bear on the opposite side. The air hammer trigger is then pressed, which operates the chisel and very quickly splits nuts up to $\frac{5}{8}$ in. in size.

AN EFFICIENT MACHINE FOR FINISHING CROWN STAYS

The finishing of crown stays is a job for which standard types of machines are not well adapted. Cutting the thread under the head of the stay requires considerable time with the ordinary arrangement. To overcome this difficulty the Columbus, Ohio, shops of the Pennsylvania Lines have constructed a special machine for finishing crown stays. This device, which was converted from an early make of Jones & Lamson flat turret lathe, is shown in Fig. 1. The principal features of the device are the tool for forming the head and the box tool for turning the end of the stays, which are mounted on a slide on the turret carriage, and a split self-opening die mounted on a swinging arm.

The forming tool which finishes the space under the head, is carried in a holder which has an eccentric to bring it into the cutting position, or to hold it away from the work. The

outer end of the slide carries a centering guide and a box tool, which is adjustable to various sizes. The split die carries the usual set of four chasers and also a nicking tool operated by a lever, which is used to form a recess under the head of the stay. The details of construction of the die head are shown in Fig. 2. The usual mechanism for

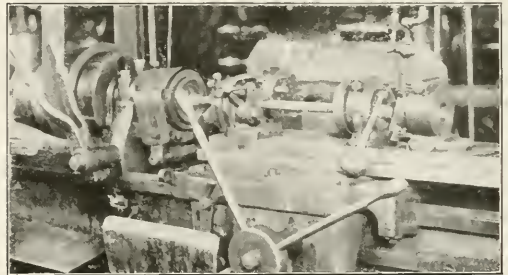
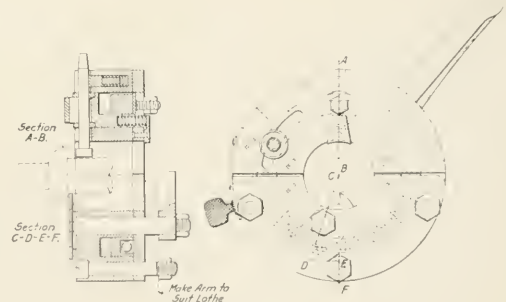

Fig. 1—Turret Lathe Fitted up for Finishing Crown Stays.

closing, locking and tripping the die is used. The body is fitted with a hinge so that it may be opened and passed over the stay. On the side opposite the hinge is a spring latch for holding the die in the closed position. The ring, fitted with cams which hold the cutters in place, is parted to bring the ends of the two halves at the dividing line of the body when the chasers are in the open position.



No. 2—Details of Hinged Self-Opening Die.

When finishing crown stays on this machine the position of the box tool is adjusted on the slide, so that the cut on the large end will be completed at about the same time that the forming tool begins to face the head. The head of the stay is slipped through the holder for the forming tool and placed in the chuck, the outer end is run through the cen-

tering guide and the cut is started with the box tool. The forming tool is placed in the cutting position and the head is shaped. As soon as these two cuts are finished the carriage is moved back until the end of the stay rests in the centering guide. The arm carrying the split die is swung forward into position as shown in Fig. 3. The recess is

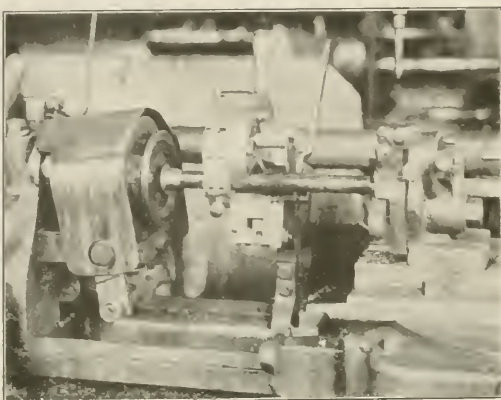

Fig. 3—Die Swang in Place over Crown Stay, Open Position.

cut under the head with the nicking tool and the thread is chased. The crown stay is then removed from the machine and the outer end is threaded on a bolt cutter. The entire operation on this machine is finished in a minute and a half.

WELDING FIREBOX PATCHES AND CRACKS

BY E. D. JOHNSON

A great deal of trouble has been experienced in welding firebox patches by either the electric or oxy-acetylene process. It is very difficult to provide for the expansion and contraction in welding straight seams. Often the welder looks his work over admiringly when it is finished and before he gets out of the firebox the contraction causes the seams to break. After experimenting with patches of va-

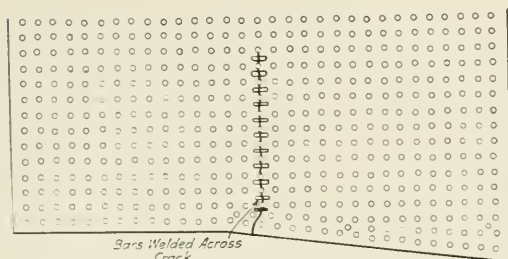

Fig. 1—Method of Reinforcing Welded Cracks

rious shapes in an endeavor to overcome the trouble, I have found what I call the serpentine patch to be the best.

This type of patch is laid out as shown in Fig. 2. The seams in the stayed surface do not extend in a straight line for more than 12 in. at any point. It is almost always possible to lay out a patch in this way by alternating the seams between different rows of staybolts. The expansion and contraction of the sheet does not cause any trouble where this

arrangement is used. Patches made in this way have been in service for three years and have required no attention during that time. When welding in patches it is best to build the weld up flush with the sheet for 6 or 8 in., then brush off the oxide which forms with a wire brush and re-inforce the weld with not more than 1/16 in. of metal. No more should be applied because an excessive amount added to the weld results in over-heating when the locomotive is in service.

As a rule it is best not to weld cracks over 10 in. long, but where necessary longer cracks can be welded successfully

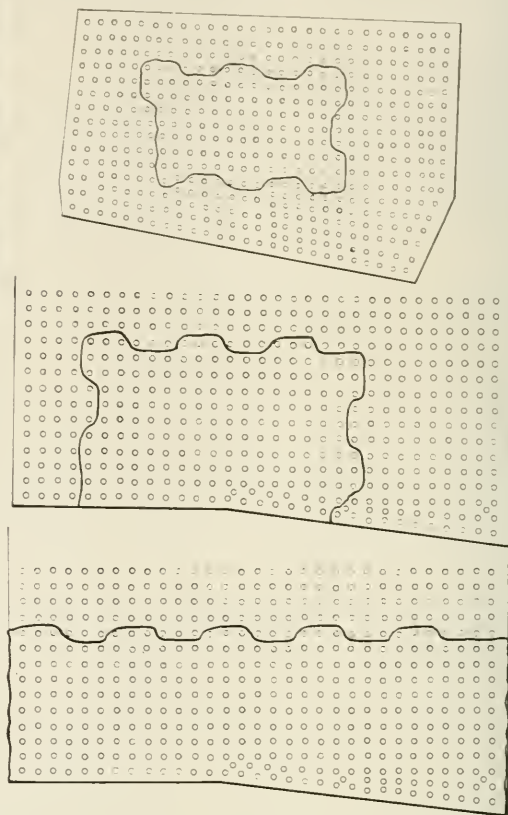

Fig. 2—Serpentine Seams as Applied to Patches and Half Side Sheets

by building the weld up flush with the sheet, then cutting transverse grooves two or three inches apart as shown in Fig. 1, laying 1/4-in. steel rods in the grooves and welding over them for the entire length. In this way the sheet is made stiffer and in addition the rods must be broken before the weld can crack.

MACHINE FOR COLLECTING BARBED WIRE SCRAP.—Among the novelties produced by the war is a machine invented by Thomas Marshall, of Stanningley, England, for collecting barbed wire scrap in war-destroyed areas. The machine, which has a remote resemblance to a straw and hay elevator, is carried on caterpillar chain tracks. The wire scrap is picked up and cut into lengths and then dumped into cars or pressed into bales.—*The Engineer, London.*

MILLING PRACTICE IN RAILWAY SHOPS

Interesting Examples of Cutters Used with Success
at the Southern Pacific Shops in Sacramento, Cal.

BY FRANK A. STANLEY

OWING, undoubtedly, to the wide-spread and early adoption of the planer, shaper and slotter in railroad shop practice, and also to the fact that a great deal of the work handled in the railway shop is necessarily of a special class with comparatively few duplicate pieces to be made at one time, there has been less development of the use of the milling machine in such places than in many other classes of manufacturing and repair shops. This has been true in spite of the fact that today the milling machine with its facilities for holding work of all kinds and its possibilities as a rapid tool for machining any kind of work to which a rotary cutter can be applied, is essentially a general purpose machine which has its legitimate field not only in the high

ness in the design of the machine. The cutter teeth are sometimes milled straight across the face, that is parallel to the axis, when in many instances and particularly with broad faced slabbing or surfacing mills far better results would be secured by a helical or spiral form of tooth which because of its shearing action upon the work surface would give an easier, smoother cut.

ADVANCE IN CUTTER PRACTICE

Some interesting practices in cutter making and modern milling methods are to be found at the Southern Pacific shops at Sacramento, California. At this place a good many classes of work are regularly handled on the milling machine



Fig. 1—Cutter Tooth Proportions

Fig. 2—A Group of Modern Cutters

Fig. 3—Old and New Shank Mills

production factory where parts are manufactured in great quantities but also in repair and general machine shops where perhaps only a few pieces of a kind are ever put through in one lot.

Because of the restricted uses to which the miller as a rule has been applied in the railroad shop there has been less advance in the development of milling cutters in such establishments than is desirable and this has done much toward retarding the extension of the machine itself as a most useful factor in the handling of many operations therein. For the machine to be effective it must be equipped with suitable cutters, cutters having teeth of coarse pitch and ample chip space between the teeth, they must be capable of taking a very heavy chip when used on a machine of rigid design and ample pulling power. Milling machine design and the design of cutters by regular manufacturers have in a sense kept pace with each other and the shops equipped with suitable machines and with correspondingly good cutters derive the full benefits of milling, whether gauged by the quantity of work produced, the quality of the work, or both.

COMMON TROUBLES WITH CUTTERS

It is a common fault to grind milling cutters too small in diameter and their teeth too fine a pitch, leaving insufficient space for the chips between them and causing too many teeth to be in contact with the work surface at one time. The teeth will not have a free cutting action and both the cutter and the work will be unduly heated. This condition is still further aggravated by an unsatisfactory flow of lubricant for cooling and clearing the teeth and work. The cutter is sometimes carried on too light an arbor for smooth operation, the springing of the cutter under these conditions producing a chatter on the work surface which is made more pronounced when the work is improperly supported or because of weak-

ness in the design of the machine. The cutter teeth are sometimes milled straight across the face, that is parallel to the axis, when in many instances and particularly with broad faced slabbing or surfacing mills far better results would be secured by a helical or spiral form of tooth which because of its shearing action upon the work surface would give an easier, smoother cut.

Comparison of Cutter Teeth.—A few illustrations will serve to show the improvement found in the form and number of teeth now used in the milling cutters at this shop.

Fig. 1 shows at a glance the improved practice in tooth form and character as exemplified by two ordinary sizes of cutters, one a plain mill about 6 in. long by 4 1/2 in. diam-

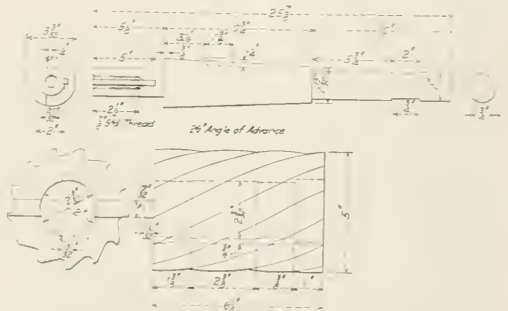

Fig. 4—Details of Milling Cutter for Vertical Machine

eter, the other a side or straddle mill of about the same diameter with a face of 1 1/2 in. The two cutters at the right in this view are of the old design with closely spaced, fine teeth. The three cutters to the left in the group are of the type now made for some years back at this place but only too seldom seen in use even today in the general run of shops.

The old form of side cutter shown was made with 40

teeth for this diameter and obviously the spacing between teeth is insufficient to permit of economical rates of speed and feed and of satisfactory clearance for chips. Furthermore, as such a cutter becomes worn down and is recut for future service, the objectionable feature of fine tooth pitch becomes even more marked, that is, it increases in direct ratio to the reduction in diameter and the ultimate life of the cutter is materially shortened.

Coarse Pitch Examples.—With the newer, coarse tooth cutters referred to there are only 20 teeth for the same diameter and all of the advantages of properly proportioned cutting teeth and clearance space are accordingly secured. The differences in tooth characteristics between the fine and

teeth so closely spaced as to become ineffectual after they have been ground down to a limited extent. The respective working qualities of the two kinds of cutters are too apparent to require special comment at this moment.

Details of Cutter Proportions.—The coarse toothed cutters have become established tools at these shops,

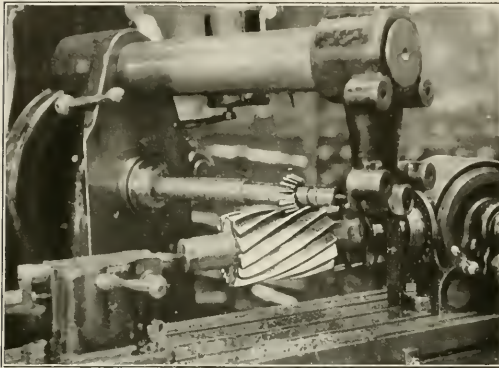

Fig. 5—Recutting a Worn Milling Cutter

coarse pitch cutters are even more conspicuously brought out upon comparison of the two spiral cutters at the rear of the group in Fig. 1, where the older example at the right is provided with 22 teeth while the later cutter at the left has only 13 teeth.

This feature of coarse teeth has been adhered to in all classes of cutters made here. For instance, note the various examples in Fig. 2 where several distinctive types of cutters,

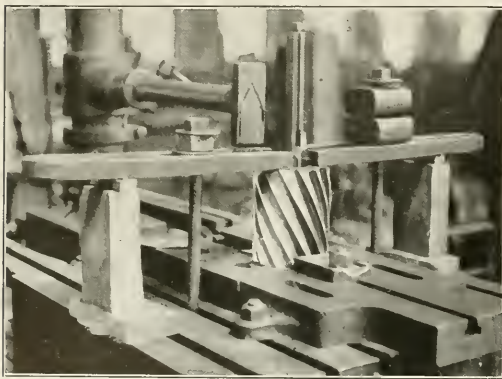

Fig. 6—Putting Arbor Keyway in Cutter

large and small, are grouped together, all with liberal spacing between teeth. And, for another illustration in the way of comparison of coarse and fine pitch, note also the four mills in Fig. 3, all nominally 2 in. in diameter, with the two at the right cut with very coarse teeth and sharp angle of helix, while the other two are of the old design with

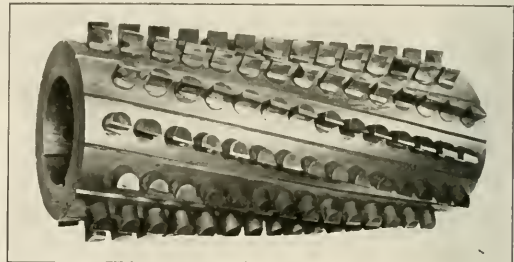

Fig. 7—Large High Speed Steel Milling Cutter

and it may be of interest here to show details of one size of cutter which has already been noted in relation to the groups in Figs. 1 and 2. This particular form of cutter is used on a heavy vertical spindle milling machine and its dimensions as well as the proportions of its arbor are covered by the drawing shown in Fig. 4. The cutter is $6\frac{1}{8}$ in. long by 5 in. diameter. It has 13 teeth cut to an advance angle of 26 deg. or one turn in 30 in. The teeth are cut with a 70 deg. milling cutter, to a depth of $\frac{3}{8}$ -in. and are provided with a $\frac{7}{32}$ -in. fillet at the bottom. The gap between teeth will amount to about $2\frac{1}{4}$ cu. in. for each tooth; thus ample chip space is provided for heavy milling operations. The bore of the cutter where it fits the arbor is

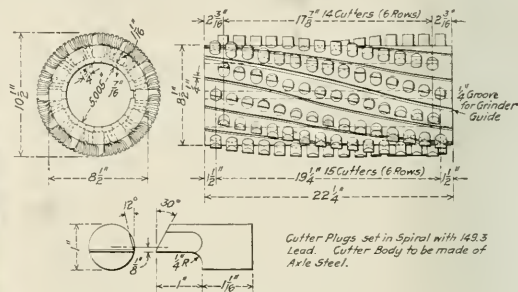

Fig. 8—Construction of Inserted Tooth Milling Cutter

2 in.; there is a bearing surface at each end $1\frac{3}{8}$ in. long and a keyway at one end for a $\frac{3}{8}$ -in. key.

Cutters of this design after they have been ground in re-sharpening to a point where the teeth require reforming, are recut and this process is repeated until the outside diameter has been reduced to $3\frac{3}{8}$ in., which means that only a $5\frac{1}{16}$ -in. wall remains between the bore and the bottom of the tooth fillet. But even with this marked reduction in diameter, the teeth are amply coarse and the space between them sufficient to give satisfactory results.

Fig. 5 represents the process of recutting a mill of this pattern. To all appearances the work is quite like a fresh cutter except for the narrowing down of the land at the top of the tooth (which will of course be ground after the cutter is again hardened and tempered) and the generally smaller diameter of the mill at both top and bottom of the tooth. This

view illustrates an interesting example of tool room work in that it shows the universal milling machine set up with its spiral dividing head for rotating the cutter through the desired angle of helix and for indexing for one tooth after another as fast as successive fluting cuts are made.

Another operation on a similar cutter is shown in Fig. 6 to show the simple process of putting in the keyway for a new cutter. Here the cutter is shown set up on the vertical key seater where it is handled in the same manner as any good job of keyseating would be put through the machine.

INSERTED TOOTH CUTTERS

An example of one of the latest milling cutters developed at this shop is the inserted tooth mill shown in Figs. 7 and 8. This cutter is used with another of the same dimensions on a heavy horizontal milling machine for slabbing loco-

of the center as indicated in the detail, and their ends are relieved or backed off at an angle of 30 deg.

This mill is shown in operation in the lower part of Fig. 9, one of these views representing one cutter in the process of slabbing off the broad face of a side rod forging while in the other a pair of cutters are set up for milling the edges of rods. With the machine set up thus provision is made for facing four rods at once with the two cutters, but at the time the photograph was taken this lot of rods had been completed except for the two shown in place, hence the cutter on the left end of the spindle is not represented in operation. The depth of cut along the edges of the forgings will average from $\frac{3}{8}$ to $\frac{1}{2}$ in. and at the big end it runs up to about $2\frac{1}{2}$ in. for a short distance. The cutter is driven at 22 revolutions per minute which gives a surface speed of 60 feet per minute. The rate of feed is 2 in. per

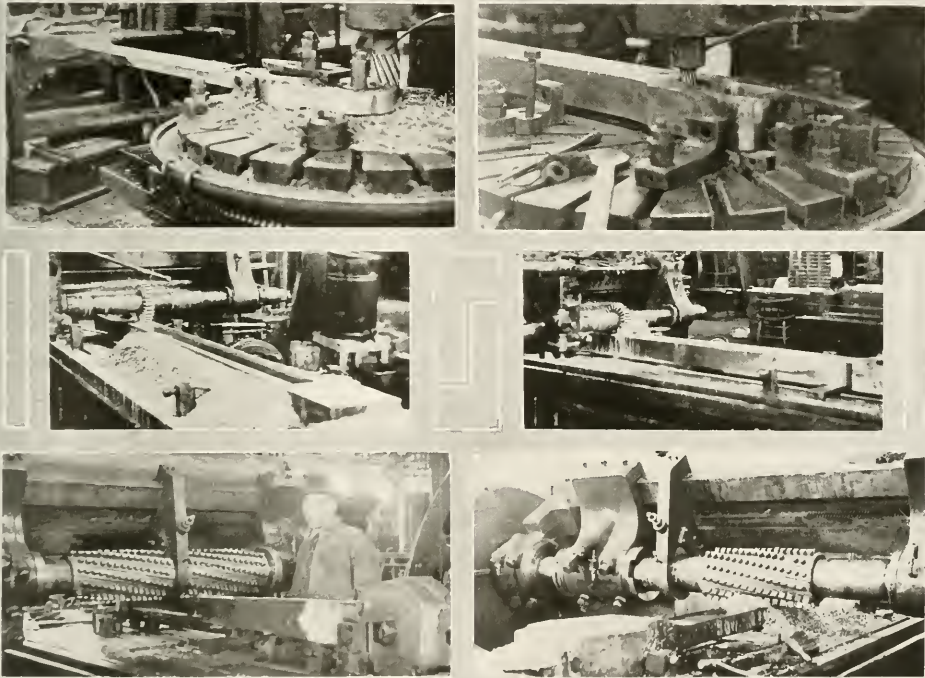

Fig. 9—Examples of Locomotive Work Done with Modern Milling Cutters

otive side rods and other large members of similar requirements.

The cutter is $22\frac{1}{4}$ -in. long over all; it measures 10 $\frac{1}{2}$ in. in diameter and has 12 rows of inserted teeth or cutter lugs staggered in alternate rows and numbering 174 plugs in all. These plugs are of Mushet steel inserted in one inch holes bored radially in an axle-steel center. Here they are set in to a depth of 1 $\frac{1}{16}$ in. and the alternate rows are staggered to cover with one row the gaps left between the teeth of the next row. The spiral line along which the teeth are located has a lead of 149.3 in., the equivalent of an angle with the axis of approximately 12 deg. The cutting faces of the plug teeth are milled $\frac{1}{8}$ -in. ahead

minute. The facing of the side of the rod is accomplished with the milling cutter running at 22 revolutions per minute and with a feed of $1\frac{1}{2}$ in. per minute. The depth of metal removed in the one cut is $\frac{3}{8}$ in. for each side of the forging. The cutter has a 5-in. bore, giving some conception of the dimensions of the carrying and supporting members.

SOME MILLING OPERATIONS

Fig. 9 shows several characteristic jobs done with these milling cutters. The picture at the top and left shows some work being finished by the milling cutter illustrated in Fig. 4. The job underway is the milling of the edge of a front side rod at the rounded rear end where the forging is about 4 in.

deep at the broadest point and the amount of metal to be removed ranges from say $\frac{3}{8}$ to $\frac{5}{8}$ in. on a side. The cutter is rotated at 30 r. p. m. giving it a surface speed of 45 ft. per minute and the work is fed at about 2 in. per minute while the circular end is being milled, the rate being higher for the straight portions along the sides. The surface is finished in the one cut.

Another job of connecting rod milling is shown at the right, where a 2-in. shank mill is seen in the vertical spindle miller in operation in the opening for the main rod wedge. This mill is necessarily of slender proportions owing to the restricted space in which it is operated and it is consequently fed at a slower rate than that maintained for the larger cutter in the preceding illustration. This slender mill, however, has the same coarse tooth and is in fact similar to the two shank mills seen to the right in the group in Fig. 3. The depth of cut through the rod is 4 in. and the liberal chip space between teeth is of especial advantage. Aside from the fact that the form of tooth made this possible it gives a stronger tool and permits a much cleaner cutting action when being operated.

Two views of channelling operations in locomotive main rods are also shown in Fig 9. Here a 7-in. side cutter is used on the horizontal miller, the cutting having a face of 2 in. and two cuts being taken from end to end to bring the channel to desired width. Each cut is made full depth. The length of the cut is about 65-in. and the depth to which the cutter is sunk in milling the channel is $1\frac{3}{4}$ in. With this deep cut a feed of nearly 2 in. per minute is maintained and the time for each of the two parallel cuts to form the channel is a little less than 40 minutes. The cutter arbor is driven at 50 r. p. m., giving a cutter surface speed of approximately 85 ft. per minute.

With all of the operations illustrated in this article a liberal supply of lubricants is provided for the cutter and the work.

NOVEL METHOD OF DRIVING DRILLS

In the drawing below is shown a method of driving large drills, reamers, etc., to relieve the stresses on the tang of the tool, which is used in the West Burlington (Iowa) shops of the Chicago, Burlington & Quincy. The spindle of the drill press has a keyway at the lower end in line with the

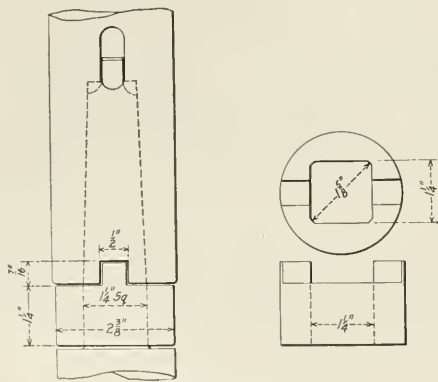

Collar Used for Driving Large Drills

socket for the tang. The tool to be used in the drill press is squared just below the shank with two sides parallel with the tang. A collar is made to fit over this square, with lugs on the upper side to match the keyway in the spindle. Thus

the force is transmitted from the spindle to the drill through the collar. The dimensions shown in the accompanying sketch are those used for collars to fit tools having a No. 4 Morse taper shank.

JIG FOR MACHINING NUTS

BY J. LEE

Shop Engineer, Canadian Pacific, Winnipeg, Man.

The jig illustrated is for use on lathes in facing and machining nuts and similar threaded work, such as wrist pin nuts, knuckle pin nuts, grease plugs, etc. It consists primarily of a fitting *B* which is made up in various sizes to suit the nuts which are to be made. This fitting is threaded on the left hand end to suit the adapter *A* which screws on the lathe spindle. The right hand end of *B* is bored and slotted to receive the tapered spindle *C* and the taper key *D*.

In operation the adapter *A* is screwed on the lathe spindle

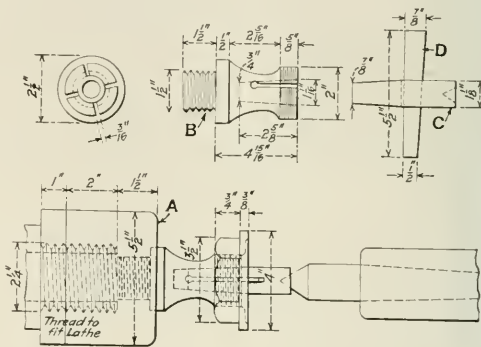

Method for Facing Nuts.

and the fitting *B* screwed into the adapter. The nut is then turned on to *B* by hand. The spindle *C* is inserted and the tailstock center is used to force it into *B*. This opens the four slots in *B*, thereby tightening the nut firmly in place. After the nut has been faced down or machined to the thickness required, the tail center may be backed out and the taper key *D* is used to withdraw the spindle, a tapered slot in *C* being provided for this purpose. This jig will be found a material time saver where there are many nuts to be machined or thinned down.

A NEW TYPE OF GEAR-BOX CONSTRUCTION.—In a permanent mesh change speed gear-box invented in England, each pair of gears is provided with a spring operated clutch which tends to keep it in operation, but, by a system of levers, all clutches but the one selected are held out of contact at a time.—*The Engineer, London.*

THE WAGE INCREASE.—Take the first three numbers of your 1917 automobile license and add it to the size of your shoes, then subtract the number of buttons missing from your last summer's suit and divide by the size of your collar. Add to this the total amount of your unpaid taxes and laundry bills and divide by eighty per cent of your telephone number. Next add the combined weight of your family plus your serial number in the draft and divide by the total number of speeches that Mr. McAdoo has made on the increase for railroad employees. The result will be the amount of increase in rate of pay that you may expect.—*The M. K. & T. Employees Magazine.*

SHOPMEN'S WAGES ARE INCREASED

The Car Department Men Receive a Minimum Hourly Wage of 58 Cents; Locomotive Men 68 Cents

THE full text of Supplement No. 4 to General Order No. 27 provides for increases to shopmen of nearly all classes, but a further increase is expected for some of the higher skilled trades which have hitherto enjoyed a differential, such as pattern makers, passenger car repair men, oxy-acetylene, thermit and electric welding, car repair work, etc. These trades have requested a further hearing and their case will be taken up before the Board of Railroad Wages and Working Conditions.

The full text of Supplement No. 4 follows:

In the matter of wages, hours, and other conditions of employment of employees in the mechanical departments (specified herein) of the railroads under Federal control it is hereby ordered:

ARTICLE 1.—CLASSIFICATION OF EMPLOYEES.

SECTION 1.—Machinists.—Employees skilled in the laying out, fitting, adjusting, shaping, boring, slotting, milling, and grinding of metals used in building, assembling, maintaining, dismantling, and installing locomotives and engines (operated by steam or other power), pumps, cranes, hoists, elevators, pneumatic and hydraulic tools and machinery, scale building, shafting and other shop machinery; ratchet and other skilled grinding and reaming, tool and die making, tool grinding and machine grinding, axle, wheel and tire turning and boring; engine inspecting, air equipment, lubricator and injector work; removing, replacing, grinding, bolting and breaking of all joints on superheaters, oxy-acetylene, thermit and electric welding on work generally recognized as machinists' work; the operation of all machines used in such work, including drill presses and bolt threaders using a facing, boring or turning head or milling apparatus, and all other work generally recognized as machinists' work.

1-A.—Machinist apprentices.—Include regular and helper apprentices in connection with the above work.

1-B.—Machinist helpers.—Employees assigned to help machinists and apprentices. Operators of all drill presses and bolt threaders not equipped with a facing, boring or turning head or milling apparatus, bolt pointing and centering machines, wheel presses, bolt threaders, nut tappers and facers; cranesmen helpers, tool-room attendants, machinery oilers, box packers and oilers; the applying of couplings between engines and tenders, locomotive tender and draft rigging work, except when performed by carmen.

SECTION 2.—Boilermakers.—Employees skilled in laying out, cutting apart, building or repairing boilers, tanks and drums, inspecting, patching, riveting, chipping, caulking, flanging and flue work; building, repairing, removing and applying steel cabs and running boards; laying out and fitting up any sheet iron or sheet steel work made of 16 gage or heavier, including fronts and doors; gate and grate rigging, ash pans, front end netting and diaphragm work; engine tender steel underframe and steel tender truck frames, except where other mechanics perform this work; removing and applying all stay bolts, radicals, flexible caps, sleeves, crown bolts, stay rods and braces in boilers, tanks and drums, applying and removing arch pipes; operating punches and shears for shaping and forming, pneumatic stay bolt breakers, air rams and hammers; bull, jam and yoke riveters; boilermakers' work in connection with the building and repairing of steam shovels, derricks, booms, housings, circles and coal boggies; eye beam, channel iron, angle iron and tee iron work; all drilling, cutting and tapping, and operating rolls in connection with boilermakers' work; oxy-acetylene, thermit and electric welding, on work generally recognized as boilermakers' work; and all other work generally recognized as boilermakers' work.

2-A.—Boilermaker apprentices.—Include regular and helper apprentices in connection with the above work.

2-B.—Boilermaker helpers.—Employees assigned to help boilermakers and their apprentices. Operators of drill presses and bolt cutters in the boiler shop, punch and shear operators (cutting only bar stock and scrap).

SECTION 3.—Blacksmiths.—Employees skilled in welding, forging, shaping, and bending of metal; tool dressing and tempering; spring making, tempering, and repairing; potashing, case and bicarbonate hardening; flue welding under blacksmith foreman; operating furnaces, bulldozers, forging machines, drop-forging machines, bolt machines and Bradley hammers; hammersmiths, drop hammersmen, trimmers, rolling mill operators; operating punches and shears doing shaping and forming in connection with blacksmiths' work; oxy-acetylene, thermit and electric welding on work generally recognized as blacksmiths' work, and all other work generally recognized as blacksmiths' work.

3-A.—Blacksmith apprentices.—Include regular and helper apprentices in connection with the above work.

3-B.—Blacksmith helpers.—Employees assigned to helping blacksmiths and apprentices; heaters, hammer operators, machine helpers, drill press and bolt-cutter operators, punch and shear operators (cutting only bar stock and scrap), in connection with blacksmiths' work.

SECTION 4.—Sheet-metal workers.—Sheet-metal workers shall include tinners, coppermiths and pipe fitters employed on shop yards and buildings and on passenger coaches and engines of all kinds, skilled in the building, erecting, assembling, installing, dismantling and maintaining parts made of sheet copper, brass, tin, zinc, white metal, lead and black planished

and pickled iron of less than 16 gage, including brazing, soldering, tinning, leading and babbiting; the bending, fitting, cutting, threading, brazing, connecting and disconnecting of air, water, gas, oil and steam pipes; the operation of babbit fires and pipe-threading machines; oxy-acetylene, thermit and electric welding on work generally recognized as sheet-metal workers' work, and all other work generally recognized as sheet-metal workers' work.

4-A.—Sheet metal worker apprentices.—Include regular and helper apprentices in connection with the above.

4-B.—Sheet metal worker helpers.—Employees regularly assigned as helpers to assist sheet metal workers and apprentices.

SECTION 5.—Electrical workers, first class.—Employees skilled in repairing, rebuilding, installing, inspecting and maintaining the electric wiring of generators, switchboards, motors and controls, rheostats and control, static and rotary transformers, motor generators, electric head lights and headlight generators; electric welding machines, storage batteries and axle lighting equipment; pole lines and supports for service wires and cables, catenary and monorail conductors and feed wires, overhead and underground winding armatures, fields, magnet coils, rotors, stators, transformers and starting compensators; all outside and inside wiring in shops, yards, and on steam and electric locomotives, passenger train and motor cars, and include wiremen, armature winders, switchboard operators, generator attendants, motor attendants, substation attendants, electric crane operators for cranes of 40 tons capacity or over; cable splicers, linemen and groundmen, signalmen and signal maintainers, wire handling wires and apparatus carrying 240 volts or over, or in dense traffic zones, and all other work properly recognized as first-class electrical workers' work.

5-A.—Electrical workers, second class.—Operators of electric cranes of less than 40 tons capacity; linemen and groundmen, signalmen and signal maintainers, wire handling wires and apparatus carrying less than 240 volts, and in normal traffic zones, and all other work properly recognized as second-class electrical workers' work.

5-B.—Electrical worker apprentices.—Include regular and helper apprentices in connection with the above.

5-C.—Electrical worker helpers.—Employees regularly assigned as helpers to assist electrical workers and apprentices, including electric lamp trimmers who do no mechanical work.

SECTION 6.—Carmen.—Employees skilled in the building, maintaining, dismantling, painting, upholstering, and inspecting of all passenger and freight train cars, both wood and steel; planing mill, cabinet and bench carpen work, pattern and flask making, and all other carpenter work in shop and yards; carmen's work in building and repairing motor cars, lever cars, hand cars, and station trucks; building, repairing, removing, and applying locomotive cabs, pilots, pilot beams, running boards, foot and headlight boards, tender frames and trucks; pipe and inspection work in connection with air-brake equipment on freight cars; applying patented metal roofing; repairing steam-heat hose for locomotives and cars; operating punches and shears doing shaping and forming, hand forges and heating torches, in connection with carmen's work; painting, varnishing, surfacing, lettering, decorating, cutting of stencils and removing paint; all other work generally recognized as painters' work under the supervision of the locomotive and car departments; joint car inspectors, car inspectors, safety appliance, and train-car repairers, wrecking derrick engineers, and wheel-record keepers; oxy-acetylene, thermit, and electric welding on work generally recognized as carmen's work, and all other work generally recognized as carmen's work.

6-A.—Carmen apprentices.—Include regular and helper apprentices in connection with the above.

6-B.—Carmen helpers.—Employees regularly assigned to help carmen and apprentices; car oilers and packers, material carriers, and rivet heaters; operators of bolt threaders, nut tappers, drill-presses, and punch and shear operators (cutting only bar stock and scrap).

SECTION 7.—Molders.—Include molders, cupola tenders, and core makers.

7-A.—Molder apprentices.—Include regular and helper apprentices in connection with the above.

7-B.—Molder helpers.—Employees regularly assigned to help molders, cupola tenders, core makers and their apprentices.

ARTICLE II—RATES AND METHOD OF APPLICATION.

SECTION 1. For the above classes of employees (except carmen, second-class electrical workers, and all apprentices and helpers), who have had four or more years' experience and who were on January 1, 1918, receiving less than 55 cents per hour, establish basic minimum rate of 55 cents per hour, and to this basic minimum rate and all other hourly rates of 55 cents per hour and above, in effect as of January 1, 1918, add 13 cents per hour, establishing a minimum rate of 68 cents per hour.

SECTION 1-A. For carmen and second-class electrical workers who have had four or more years' experience and who were on January 1, 1918, receiving less than 45 cents per hour, establish a basic minimum rate of 45 cents per hour, and to this minimum basic rate and all other hourly rates of 45 cents and above, in effect as of January 1, 1918, add 13 cents per hour, establishing a minimum rate of 58 cents per hour.

SECTION 1-B. Rates of compensation exceeding the minimum rates established herein to be preserved; the entering of employees in the service or the changing of their classification or work shall not operate to establish a less favorable rate or condition of employment than herein established.

SECTION 1-C. The Director General recognizes that the minimum rates established herein may be exceeded in the case of men of exceptional skill,

who are doing special high-grade work, which has heretofore enjoyed a differential. Such cases would include pattern makers, passenger car repair men, oxy-acetylene, thermite, and electric welding in car repair work, etc., and should be presented to the Board of Railroad Wages and Working Conditions for recommendation as provided in General Order No. 27.

SECTION 2. The above classes of employees (except carmen, second-class electrical workers, and all apprentices and helpers) who have had less than four years' experience in the work of their trade will be paid as follows:

- (a) One year's experience or less, 50 cents per hour.
- (b) Over one year and under two years' experience, 53 cents per hour.
- (c) Over two years' and under three years' experience, 57 cents per hour.
- (d) Over three years' and under four years' experience, 62 cents per hour.

SECTION 2-A. Carmen and second-class electrical workers who have had less than four years' experience in the work of their trade will be paid as follows:

- (a) One year's experience or less, 48½ cents per hour.
- (b) Over one year and under two years' experience, 50½ cents per hour.
- (c) Over two years' and under three years' experience, 52½ cents per hour.
- (d) Over three years' and under four years' experience, 54½ cents per hour.

SECTION 2-B. At the expiration of the four-year-period the employees mentioned in section 2 and section 2-A shall receive the respective minimum of their craft.

ARTICLE III.

SECTION 1. Regular apprentices between the ages of 16 and 21, engaging to serve a four-year apprenticeship, shall be paid as follows: Starting-out rate and for the first six months, 25 cents per hour, with an increase of 2½ cents per hour for each six months thereafter up to and including the first three years; 5 cents per hour increase for the first six months of the fourth year and 7½ cents per hour for the last six months of the fourth year.

SECTION 1-A. If retained in the service after the expiration of their apprenticeship, apprentices in the respective trades shall receive not less than the minimum rate established for their craft.

SECTION 2. Helpers in the basic trades herein specified will be paid 45 cents per hour.

SECTION 3. Helper apprentices will receive the minimum helper rate for the first six months, with an increase of 2 cents per hour for every six months thereafter until they have served three years.

SECTION 3-A. Fifty per cent of the apprentices may consist of helpers who have had not less than two consecutive years' experience in their respective trades in the shop on the division where advanced. In the machinist, sheet metal worker, electric and molder trades the age limit for advancement will be 25 years; in the boilermaker, blacksmith, and carmen trades 30 years.

SECTION 4. In the locomotive and car departments gang foremen or leaders and all men in minor supervisory capacity and paid on an hourly basis will receive 5 cents per hour above the rates provided for their respective crafts.

SECTION 5. The supervisory forces of the locomotive and car departments, paid on a monthly basis and exercising supervision over the skilled crafts, will be paid an increase of \$40 per month in addition to the monthly rate as of January 1, 1918, with a minimum of \$155 per month and a maximum of \$250 per month.

ARTICLE IV.—GENERAL APPLICATION.

SECTION 1. Each railroad will in payments to employees on and after July 1, 1918, include these increases therein.

SECTION 1-A. The increases in wages and the rates established herein shall be effective as of January 1, 1918, and are to be paid according to the time served to all who were then in the railroad service, or who have come into such service since, and remained therein. A proper ratable amount shall also be paid to those who for any reason since January 1, 1918, have been dismissed from the service, but shall not be paid to those who have left it voluntarily. Men who have left the railroad service to enter the military service of the Army or Navy shall be entitled to the pro rata increase accruing on their wages up to the time they left, and the same rule shall apply to those who have been transferred from one branch of the railroad service, or from one road, to another.

SECTION 2. The hourly rates named herein are for an eight-hour day, and one and one-half time will be paid for all overtime, including Sundays and the following holidays: New Year's Day, Washington's Birthday, Decoration Day, Fourth of July, Labor Day, Thanksgiving, and Christmas.

SECTION 3. While the specific rates per hour named herein will be retroactive to January 1, 1918, the special overtime provisions established in section 2 of this article will be effective as of August 1, 1918, with the provision that in computing overtime to determine back pay to January 1, 1918, overtime will be paid at a pro rata rate for all overtime worked in excess of the hours constituting the recognized day or night shift, except where higher overtime rate basis exists, or has been applied, in which event the most favorable condition shall be the basis of computing back pay accruing from this order.

SECTION 4. Employees, except monthly salaried employees, coming within the scope of this order, sent out on the road for emergency service, shall receive continuous time from the time called until their return as follows: Overtime rates for all overtime hours whether working, waiting, or traveling, and straight time for the recognized straight time hours at home stations, whether working, waiting, or traveling, except that after the first 24 hours, if the work is completed or they are relieved for 5 hours or more, such time shall not be paid for, provided that in no case shall an employee be paid for less than 8 hours on week days and 8 hours at one and one-half time for Sundays and holidays for each calendar day. Where meals and lodging are not provided by the railroad an allowance will be made for each meal or lodging. Employees will receive

allowance for expenses not later than the time when they are paid for the service rendered.

SECTION 5. Employees specified herein when sent from home point to temporarily fill vacancy or perform work at outside division points, will be paid straight time and overtime rates as per shop rates, including going and return trip, in addition to which they will be paid pro rata at the rate of \$2 per day for meals and lodging.

SECTION 6. Carmen stationed at points requiring only one employee on day shift or night shift, or day and night shifts, shall be paid eight hours at not less than the hourly rate provided herein.

SECTION 7. Mechanics now regularly assigned to perform road work and paid on a monthly basis shall be paid for eight hours at not less than the hourly rate provided herein.

SECTION 8. Employees on a piecework basis shall receive not less than the minimum rate per hour awarded to the hourly workers, including time and one-half for overtime, as hereinbefore provided; otherwise piecework rates provided in General Order No. 27 shall apply.

SECTION 9. The application of this order shall not, in any case, operate to establish a less favorable wage rate than in effect January 1, 1918.

ARTICLE V.—PAYMENTS FOR BACK TIME.

SECTION 1. As promptly as possible the amount due in back pay from January 1, 1918, in accordance with the provisions of this order, will be computed and payment made to the employees, separately from the regular monthly payments, so that employees will know the exact amount of these back payments.

SECTION 2. Recognizing the clerical work necessary to make these computations for back pay, and the probable delay before the entire period can be covered, each month, beginning with January, shall be computed as soon as practicable, and, as soon as completed, payments will be made.

ARTICLE VI.—INTERPRETATION OF THIS ORDER.

SECTION 1. Railway Board of Adjustment No. 2 is authorized by Article IX of General Order No. 27 to perform the following duty:

"Wages and hours, when fixed by the Director General, shall be incorporated into existing agreements on the several railroads, and should differences arise between the managements and the employees of any of the railroads as to such incorporation, such questions of difference shall be decided by the Railway Board of Adjustment No. 2 when properly presented, subject always to review by the Director General."

SECTION 2. In addition to the foregoing other questions arising as to the intent or application of this order in respect to the classes of employees within the scope of the Railway Board of Adjustment No. 2 shall be submitted to such board, which board shall investigate and report its recommendations to the Director General.

SECTION 3. All rates applied under this order shall be filed by the Regional Directors with the Board of Railroad Wages and Working Conditions.

SECTION 4. The rates, increases, and other conditions of employment herein established for the classes of employees herein specified shall supersede the rates, increases and other conditions established by General Order 27, except as provided in section 8, Article IV.

STATEMENT BY MR. MCADOO

The concluding section of the supplement is a statement by Mr. McAdoo reading as follows:

In reaching the conclusions upon which this order is based, I have been keenly conscious not alone of the interests of the large number of railway employees who are greatly benefited thereby, but also of my solemn duty to the American people to see to it that the trust they have committed to me is discharged faithfully, with justice to them as well as to the railroad employees concerned. No right decision can be made which considers only the demands and interests of any class of men apart from the paramount interest of the public and the supreme necessity of winning this war.

Now that the decision has been made, the American people, whose servants we are, expect every railroad employee to devote himself with new energy to his work, and by faithful and efficient service, to justify the large increases of pay and the improvement in working conditions hereby granted. The American people have a right to expect this and they will be content with nothing less.

It is of the utmost importance that motive power and cars shall be kept in repair and that the output of railroad shops throughout the country shall be greatly increased in the future. Unless this is done, the railroads can not efficiently perform the increased duties imposed upon them by the war, and the fighting power of our armies in France and of our navies on the high seas will be seriously impaired.

I am proud of the loyal service the great body of railroad men throughout the country have rendered to their Government since the railroads have come under Federal control. It is a genuine pleasure to make this acknowledgment, but I

should not fail to say at the same time that there are instances where agitations and disturbances in some of the locomotive and car shops have been extremely hurtful to the country. The loyal and patriotic employees, who constitute the great majority of the army of railroad workers, have not yielded, be it said to their credit and honor, to these disturbances. But the few who have, have done their country a grievous injury by impairing the efficiency and reducing the output of the shops where these disturbances have occurred.

The loyal and patriotic employees can render a new and powerful service to their country by using their influence to expose any who may become slackers in their work, by co-operating with their officers in the enforcement of discipline, and by increasing, to the utmost limit of their capacity, the output of locomotives and cars which are so essential to the efficient operation of the railroads of the country and to the success of our armies in the field. I know I can count on the patriotism and devotion to duty of every true American engaged in the railway service of the United States.

SHOP MEN SATISFIED WITH RECENT INCREASE

Reports received by officers of the Railroad Administration are to the effect that officers and men alike are well satisfied with the increases in pay to shopmen announced in Supplement No. 4 to General Order No. 27. Mechanical officers in different parts of the country who have been heard from say that many skilled men who had left them to go into other work have begun to return to their railroad jobs and some say that the advance wages are proving sufficient to attract also skilled mechanics new to railway work. In fact, on most railroads there are more mechanical department employees on the payrolls now, in both the car and the locomotive departments, than there were at this time last year.

Men Jointly Employed.—In circular letter No. 355 the southern director draws attention to the fact that in the case of men jointly employed by several railroads, some of which are under government control and others which are not under government control, the increases in pay under General Order No. 27 will apply, even though in some instances the actual pay check may be issued by the railroad not under government control.

Compensation for Sub-Foreman.—The eastern regional director has issued the following: The following letter from C. R. Gray, director, Division of Operation, dated Washington, August 15, 1918, is quoted for your information and guidance:

Supplement No. 4 to General Order No. 27 provides that sub-foremen in the mechanical department, such as gang leaders and leading workmen, shall be paid 5 cents per hour more than the craft which they are supervising.

Our attention has been called to the fact that this creates inequalities between certain railroads on account of some of these sub-foremen having been heretofore paid on a monthly basis.

In order to preserve uniformity you may authorize Federal and general managers to place all of these men on an hourly basis.

THE COST OF OXY-ACETYLENE WELDING

In discussing the paper on electric arc and oxy-acetylene welding read by A. F. Zoelrest before the Niagara Frontier Car Men's Association, Neil Marple of the Michigan Central quoted the following figures as the cost per cubic inch of welding by the oxy-acetylene process.

Size of weld in cu. in.	Amount of gas consumed	Amount of oxygen consumed	Amount of welding metal used	Material	Labor	Total
1.3125	15 lb.	200 lb.	1 1/2 lb.	\$0.58	\$0.49	\$1.37
3.75	50 lb.	350 lb.	2 lb.	2.29	.84	3.13
2.612	30 lb.	260 lb.	2 1/2 lb.	1.49	.70	2.19
2.32	32 lb.	265 lb.	2 3/4 lb.	1.61	.91	2.52
1.265	20 lb.	200 lb.	1 1/2 lb.	1.63	.42	1.45

Acetylene 3 cents per lb., average 250 lb. per tank.
Oxygen 14 cents per cwt., average 1,800 lb. per tank.
Welding metal 10 cents per lb., Labor 42 cents per hour.

The average cost per cubic inch as shown by the above quotations is, approximately, \$1.00 per cubic inch.

A METHOD OF REGULATING SHOP OUTPUT

BY E. T. SPIDY

Did you ever hear this said in a railroad shop: "Well, one thing is sure, if we were in a manufacturing business we couldn't afford to do it this way." The writer, who has put in fourteen years in railroad shops and who now is actively engaged in an industrial shop, believes that this thought is only too common, and in consequence many manufacturing shop methods are not considered as practical to the railroadmen and in consequence get little or no consideration.

Railroad shops are simply a series of manufacturing shops where the quantity handled at one time is in some departments small and in others it is large. This point does not constitute a difference with manufacturers as many think. The difference lies in the fact that a railroad shop often does not know what it has to do until the job is right in the shop, whereas the manufacturer usually knows all the work that has to be done when he gets an order.

If, however, the railroad reader will think of the following as being applied to his shop and consider the man that he delivers his work to as his customer, he will realize that there is a mighty close relationship between his own methods and whatever he considers manufacturing methods, and though no two applications of a principle are alike, it may throw a light on future possibilities.

CONTROL OF SHOP OPERATIONS

The delivery of orders in hand is at the present time the most important job we have—most of us have, I should perhaps have said. If we have a small shop then we can perhaps recite off all our orders with precision, but if we have a large shop, and the larger we have the more difficult and the less accurate our estimates become, it is hard to know exactly where we stand with regard to each and every order.

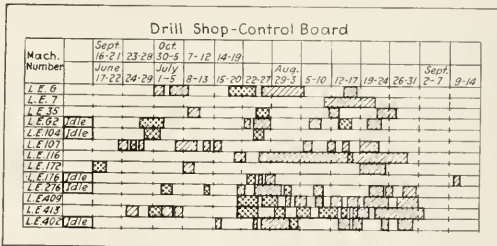

Fig. 1—An Example of the Arrangement of the Control Board

The larger the shop the further away the actual order gets from head of the shop because more bosses and sub-bosses get between the man for whom the job is being done and the man on the shop floor who is actually doing the work.

Now, while we all believe that our own way is quite right and that the other fellow's way may suit him, too, we are quite willing to admit that now and then we do pick up an idea from seeing just how the other fellow does his work, and it is with this thought in mind that the following description is written. There is no claim for any originality in the scheme, which is a natural evolution from the small shop to the big shop way of doing things.

To get a correct angle on the situation, assign yourself to the position of a supervisor who wants to get a line on what a shop is doing. You size up the number of men in the shop, you look over the machines and note what is apparently not running. You look over the list of orders which most likely numbers hundreds and you inquire into the material

situation, in fact, you get into all kinds of detail regarding that particular shop. Without a doubt you will find many ways in which you can help the man in charge, if such is your desire, to increase his output. But do you get a real idea as to the general condition of the shop and its orders as a whole? Do you know whether the delivery of orders is on the whole one week or many months late? If they are late, what is the cause? Is it the machine capacity of the shop that is delaying deliveries? Is it the lack of man power? Is it on account of too optimistic promises of deliveries? Or what is the matter?

Most of us are well aware that something is the matter, and if we are to manage the situations that are today forced on us, any means that shows us where we are off the track

each line representing one hour. The length of each ticket made out is equal to the time allowed for the job, that is to say, the length of the ticket varies with the time allowed. For instance, if the operation is to mill 25 pieces and one hour is allowed for each piece the ticket will have 25 lines for the 25 hours or be 1 1/4 in. long. The tickets are placed in the boards on the line representing the machine on which the job is to be done and under the date it must be started in order to make a certain finish date. It is obvious that if the machine chosen for the job is so loaded with other operations that this particular job has to be put back several weeks, it will be necessary to find some other machine, method, or shop to do it in if the work cannot be delayed that long. Herein is one of the big advantages of the board. We can see at a glance whether the boring mills, for instance, in Shops Nos. 4 or 5 are loaded as much as those in Shop No. 1, and do thus transfer the job if necessary. The manner in which the boards are marked is shown in Fig. 1.

Our method of handling these boards is to make out a list of the operations and the times allowed from standard schedule of operations for each job on receipt of every order on what we call a "Schedule Route Sheet" (see Fig. 2), using premium times when available and estimating them temporarily for the board purpose when times are not in the standard operation schedule. Tickets are then made for each operation. All new tickets are placed in boards at least once a day and all operations completed are also marked up or removed. All daily time cards and premium cards are

SCHEDULE ROUTING SHEET									
H. Drill No. 4		Shop		Lot No. 7752		Pieces: 25			
Description: DD17 Clutches									
Operation	Mach. No.	lot	Time (hrs.)	Date		Date			
				start	to	Date	Date	Date	Date
1. Bore, turn and end-off.	654	30	...	7 12
2. Mill clutch	198	40	...	7 15
3. Finish turning	311	13	...	7 10
4. Vise	V ₂	10	...	7 23
5. Carbonize	Car.	4	...	7 25
6. Oil treating	O.T.	10	...	7 26
7. Grind outside	314	12	...	7 29
Finish promise	8 5

Note—The last four columns of the table are for revised dates.

Remarks:

- Operation 1 started July 13.
- Operation 2 started July 17—2 scrapped.
- Operation 3 started July 21—23 pieces.
- Operation 5 waiting for compound. Started July 28.

Production Department
DAILY ORDER OF WORK SHEET

Mr. Lemire. Turrets. Date, August 6, 1918.
Shop, Drill Shop No. 4.

The Following Operations and Material Are Late or Due:

Lot No.	Date	Description	Operation	Machine No.
13477	27.7	Pins	Make	LA 285
565	27.7	Belt wheels stud.	Make	LA 285
20,86	24.7	JC10 screw	Thd. for handle.	JL 1051
19873	24.7	7/16x10 rings	Co. tn. & co.	PJ 169
19919	24.7	Valve blk. pins.	Turn thread	JL 1051
19722	19.7	43 1/2 feed nut.	Tn. bo. rm. thd. co.	JL 266
19925	19.7	Gr. shaft	ho. fe. & turn.	JL 405 Due July 27
30513	2.7	Imp. unloader plug.	Make	PJ 1949 xx
19737	4.7	Col. feet	Turn & face.	LA 285
1T637	6.7	Facing bar stop.	Tn. thr. & bore.	JL 859
1T637	16.7	Bevel mill rocker.	Fin. bo. & rgh. tn.	JL 859
19816	22.7	7x12 piston ring.	Bore & turn.	FJ 168
19337	31.7	43 1/2 feed screw	Thread handle	JL 260
116,8	31.7	200—3/4 mche. swivels.	Thr. pipe end.	PJ 1049
565	6.8	Holding device screw.	Make	JL 143 Late xx
19338	6.8	43 1/2 feed screws.	Thread handles	JL 268
30560	6.8	Crank pin cap screw.	Make	JL 268
30554	6.8	1 1/8x6 in. cap screw.	Make	JL 1043
13467	6.8	1 1/2 in. cap screw.	Make	JL 1043
565	6.8	Inlet valve screw.	Make	PJ 1049
566	6.8	Outlet valve screw.	Make	PJ 1049
20335	6.8	3/4 in. oil plugs.	Make	LA 152

Fig. 3—The Daily Order of Work Sheet

are very acceptable. The writer has always appreciated graphical methods because they give direct readings without any figuring and has found the following methods effective.

In the first place a survey of a plant naturally divides all departments into manufacturing departments and supply departments. The manufacturing shops are those with orders for finished work and all other departments are in the nature of supply depots or sources of supply for material. Now in many shops every boss goes to the source of supply himself and places his order, traces it up until he gets it. The boss with the most persuasive power usually gets the most, sometimes delaying more important orders in other departments. This continual "When can I get this?" and "When can I promise that for?" ends in the average case in most every job being promised for "two weeks" with the effect known only too well.

The writer has been led to the conclusion that the clearing house system as applied by the banks is the right idea for interdepartmental operations. Instead of 100 (more or less) bosses being in communication with each other, they all communicate with one central department which issues and receives all orders to all departments. In this central department are a series of boards which we call "Machine Loading Boards" or "Control Boards," one board being used for each shop. These boards contain a series of slots from top to bottom extending the complete width of the board. The left hand side of each slot is labelled with the machine number and symbol or man's name and all operations done at that machine are put into that slot. Along the top of the board is marked a series of dates covering a period of about 14 weeks. The scale used is three inches to one week, which to facilitate reading is marked all the way down the boards by white dots in weekly spacings. For each operation a ticket is made out on profile paper with 20 lines to the inch,

checked by the department each day for operations finished and started so that the boards are kept up to date all the time. An individual permanent record of each order is also kept on the schedule route sheets. Each day a "Daily Order of Work Sheet" (see Fig. 3), showing all operations due to be started and finished is issued to each assistant foreman and a complete set of sheets for each department is given to the general foreman. This sheet is made up from the shop control board and towards the end of each day a production department man checks them over with each foreman and records the delays, finished jobs, those in progress, etc., and makes a record of any other happenings influencing the work. On his return to the office each board is corrected

to correspond with the day's progress. On the tickets for work started or in progress is placed a short mark in red pencil. When the work is completely finished the ticket for the operation is marked red all over (shown by double cross-hatching in Fig. 1) and the next operation is looked up in the schedule and that ticket marked with a yellow pencil, which indicates that it must be on the next order of work sheet, and so on. The single crosshatched spaces represent work assigned to a machine but which has not been finished.

The boards will thus show at any particular period "How much work is ahead of each machine" and "How much late," and "What is late." Each day machines not working are tagged on the board with "IDLE" tickets, the reason for which is known or can be quickly ascertained.

The production department promises the delivery of all orders and thus relieves the foreman of making dates, which comparatively speaking, he has no adequate method of knowing whether he can keep. The production department is careful to make clear to every foreman that his status is in no way lowered because certain information is given him in a different way, and he is asked to regard the department as an active assistant rather than otherwise. As a matter of fact this happens as a matter of course.

One of the attractive features of this graphical method as compared with systems where the schedule of promised dates is in a book or on charts is that it is extremely flexible. We all know that a considerable number of dates have to be periodically changed. This is brought about because all orders on the shop by this method have a finish date. This is good shop practice because while we always give a customer's orders preference over stock orders the change does not let us forget it by any means. Every month each board is completely checked and the dates at the top of the board changed, one block is removed and a new block of dates inserted. It is seen in Fig. 1 that the new series of dates are appearing over the old dates on the left side, the next move the old dates will be removed entirely.

The "Foundry Control Board" is run on somewhat the same lines, but instead of dates we use a location letter on the bottom and a number on the side, to link the sheets with the board. In the foundry we know we can get so many boxes per day of one class of work and so many of another and so we arrange our "Order of Work" sheet so that the most important work is at the top. The scale used here is number of pieces instead of time allowed. The foundry boss works from the top downward in each section of the sheet under the heading "Main Floor," "Rollover," etc., which automatically makes a preference list. The order of the list is made from the dates material must be delivered to the various departments as seen from when first operation must start in each department.

We keep an accurate record of the percentage of dates that are maintained in each department according to the promises made and have thus a measure of co-operation received from each department. Record of the efficiency of every operation as compared with the base time allowed is also kept and all foremen are rewarded by a bonus dependent on the results of their own gang.

As a final word, it is seen that this is a means of keeping all work ahead clearly in view. It gives data, which, reported as soon as seen, shows conditions coming before they happen and not after when it does little good. It provides the necessary information to lead each department along, which gets co-operation instead of the drive and the criticize method.

A summary of a department which means something, is one that tells you that you have, for instance, 20,500 machine hours' work ahead represented in orders, and that since you have 60 machines in the department open for business 50 hours a week, you have 3,000 machine hours a week available, less a percentage that is idle on account of various

known reasons—say 25 per cent—which gives 2,250 machine hours actually available. This shows that you have at present standing a little over nine weeks' solid work ahead, or, in other words, some of the present orders are nine weeks away from delivery.

These are real facts, obtainable quickly from these methods. If we prefer to go any way around it to show it differently the only persons really fooled are ourselves.

MEETING OF THE IRON AND STEEL ASSOCIATION

A meeting of the American Foundrymen's Association, the Iron and Steel section of the American Institute of Mining Engineers, the Institute of Metals Division of the American Institute of Mining Engineers and the American Malleable Castings Association will be held in Milwaukee, Wis., during the week of October 7, during which time an elaborate exhibition of metal working equipment will be made in the Milwaukee auditorium.

The keynote of many of the addresses and papers that will be presented at this meeting will be toward the acceleration of production for the prosecution and winning of the war. One of the notable features will be the large number of interesting moving pictures that will be shown. These will include the use and manufacture of hand grenades, the civil re-establishment of wounded and crippled Canadian soldiers, the manufacture and launching of ships at the Hog Island yard, Philadelphia, the building of concrete ships, the manufacture of steel by the triplex process, and the cause and prevention of industrial accidents.

Among the papers to be presented at the Foundrymen's meeting, the following will be of interest:

- "Training Your Own Help Instead of Competing with Other Manufacturers," by Ernest Van Billard and T. Hough, Jr., General Railway Signal Company, Rochester, N. Y.
- Moving picture film on the "Manufacture and Use of Hand Grenades," by Maj. Frank B. Gilbreth, Providence, R. I.
- "Annealing Malleable Iron," by H. E. Diller, General Electric Company, Erie, Pa.
- "Use of Malleable Castings," by H. A. Schwartz, National Malleable Castings Co., Indianapolis.
- "White Rim or Picture Frame Fractures," by J. B. Deisher, T. H. Symington Company, Rochester, N. Y.

In the program of the Institute of Metals Division of the American Institute of Mining Engineers are:

- "Notes on Rabbit and Rabbitted Bearings," by Jesse L. Jones, Symposium on "The Conservation of Tin." This topic will be discussed by the following:
 - G. W. Thompson, National Lead Company.
 - G. H. Clamer, Ajax Metal Company, Philadelphia.
 - C. M. Waring, Pennsylvania Railroad Company.
 - M. L. Lissberger, Mark Lissberger & Son, Inc., Long Island City, N. Y.
 - D. M. Buck, American Sheet & Tin Plate Company, Pittsburgh.
 - W. M. Corse, Buffalo.
 - G. K. Burgess and Mr. W. Iward, United States Bureau of Standards, Washington, D. C.
- M. L. Dyer, War Industries Board, Washington, D. C.
- A representative of the Xiles Cement, Portland Company, New York.
- A representative of the Bureau of Steam Engineering, United States Navy Department, Washington, D. C.
- "Accident Prevention Is Good Business," by Hon. Fred M. Wilcox, vice-president, Wisconsin Industrial Commission.
- "What the Buckeye Steel Castings Company Has Accomplished in Accident Prevention," by Fred G. Pennett, safety director, Buckeye Steel Castings Company, Columbus, Ohio.
- "The Importance of Organization in Accident Prevention," by C. W. Price, field secretary, National Safety Council, Chicago.
- "What Shall Be Done with the Crippled Soldier?," by W. A. Janssen, vice-president, Canadian Steel Foundries, Montreal, Canada.

Among the many papers to be presented at the Iron and Steel Section of the American Institute of Mining Engineers, will be the following:

- "The Manufacture of Ferro-Alloys in the Electric Furnace," by R. M. Keessy.
- "Notes on Some Iron Ore Reserves of the World."
- "The Use of Coal in Pelletizing Furnaces," by H. R. Collins.
- "Carbonyl," by C. T. Malcolmson.
- "Price Fixing of Bituminous Coal by the United States Fuel Administration," by R. V. Norris and others.

The exhibit at this joint meeting will be particularly inter-

esting. Already 165 manufacturers have reserved space at the auditorium. Among these the following will show products of particular interest to railway men:

Abrasive Company, Philadelphia.
 Allis-Chalmers Manufacturing Company, Milwaukee.
 American Kron Seale Company, New York.
 E. C. Atkins & Co., Indianapolis.
 Asbury Graphite Mills, Asbury, N. J.
 Ayer Lord & Tie Company, Chicago.
 Barrett Company, Chicago.
 Beandy & Co., Boston.
 Bristol Machine Tool Company, Bristol, Conn.
 Brown Specialty Machinery Company, Chicago.
 Bullard Machine Tool Company, Bridgeport, Conn.
 Carborundum Company, Niagara Falls, N. Y.
 Central Electric Company, Chicago.
 Chard Lathe Company, New Castle, Ind.
 Cincinnati Pulley Machinery Company, Cincinnati.
 Cleveland Pneumatic Tool Company, Cleveland.
 Chipper Belt Lacer Company, Grand Rapids, Mich.
 Dale-Brewster Machinery Company, Chicago.
 Davis-Bourneville Company, Chicago.
 Detroit Drill Company, Detroit.
 Detroit Steel Products Company, Detroit.
 Joseph Dixon Crucible Company, Chicago.
 General Electric Company, Schenectady, N. Y.
 General Steel Company, Milwaukee.
 Greaves-Klusman Tool Company, Cincinnati.
 Hauck Manufacturing Company, Brooklyn, N. Y.
 Hayward Company, New York.
 Henry & Wright Manufacturing Company, Hartford, Conn.
 Herman Pneumatic Machine Company, Pittsburgh.
 Hyatt Roller Bearing Company, New York.
 Imperial Brass Manufacturing Company, Chicago.
 Industrial Electric Furnace Company, Chicago.
 Jenson-Wright Company, Toledo, Ohio.
 Kearney & Trecker Company, Milwaukee.
 Kemp-Smith Manufacturing Company, Milwaukee.
 Julius King Optical Company, Chicago.
 Lees Bradner Company, Cleveland.
 David Lupton's Sons Company, Philadelphia.
 Marshall & Huschart Machinery Company, Chicago.
 McCrosky Reamer Company, Meadville, Pa.
 Mueller Machine Tool Company, Cincinnati.
 Macleod Company, Cincinnati.
 Magnetic Manufacturing Company, Milwaukee.
 Mahr Manufacturing Company, Minneapolis.
 Metal & Thermit Corporation, New York.
 Modern Tool Company, Erie, Pa.
 Monarch Engineering and Manufacturing Company, Baltimore.
 Naper Saw Works, Springfield, Mass.
 Norma Company of America, New York.
 Norton Company, Worcester, Mass.
 Oakley Machine Tool Company, Cincinnati.
 Osterlein Machine Company, Cincinnati.
 Ohio Machine Tool Company, Kenton, Ohio.
 Oliver Machinery Company, Grand Rapids, Mich.
 Oxweld Acetylene Company, Chicago.
 Panghorn Corporation, Hagerstown, Md.
 Pawling & Harnischfeger Company, Milwaukee.
 Peerless Machine Company, Racine, Wis.
 Phoenix Manufacturing Company, Eau Claire, Wis.
 Quigley Furnace Specialties Company, New York.
 Racine Tool & Machine Company, Racine, Wis.
 Railway Mechanical Engineer, New York.
 Rivett Lathe and Grinder Company, Boston.
 Shepard Electric Crane and Hoist Company, Montour Falls, N. Y.
 Simonds Manufacturing Company, Fitchburg, Mass.
 Southworth Machine Tool Company, Portland, Me.
 Standard Optical Company, Geneva, N. Y.
 Strong, Keenard & Nitt Company, Cleveland.
 Sullivan Machinery Company, Chicago.
 Swan & Fitch Company, Chicago.
 Thomas Elevator Company, Chicago.
 Torchweld Equipment Company, Chicago.
 United States Graphite Company, Saginaw, Mich.
 Warner & Swasey Company, Cleveland.
 Western Electric Company, New York.
 Whiting Foundry Equipment Company, Harvey, Ill.

EVERY LITTLE BIT HELPS—DO A LITTLE BIT MORE

You can always do a little bit more. Just at the time you think you have exhausted every ounce of effort, you find that you are capable of still further accomplishment—and success instead of failure gladdens you!

You can lend more than you ever thought you could lend in this big War Savings Stamp campaign.

Did you ever fill a barrel of potatoes to the top until you could not get in another potato? Don't you know that you could still get in a bushel or so of beans, and a quart or two of peas, and if you wanted to do it, you could find room

for a couple of pounds of meal or bran and even after that, pour in a couple of gallons of water?

It makes no difference how much you have contributed in Liberty Bonds, if you have not done ALL that you could do you have not done your share.

What if every one considered himself the self-constituted judge of how much he should do and when he should stop? Who would go on and win the war?

No, you can always do a little bit more and you'd better do it for yourself and for your country than for the Kaiser.

TIPPING CARBON STEEL TOOLS

BY W. H. HALSEY

General Foreman, Chicago & North Western

A number of different ways of tipping carbon steel with high speed steel have been developed since the advance in price of high speed steel. Some tips are welded on by the acetylene process and others by the electric process, but the method shown in the illustration has proved to be very satisfactory at the Chicago & North Western shops, Missouri Valley, Iowa. High speed steel of the smallest sizes may be used until it is entirely worn away.

The blacksmith can perform the entire operation. At this shop an old scrap tire is worked out into tool shanks of standard sizes and the tool-smith drives his cutting-off chisel into the end of the tool shank, making a V-shaped pocket, as shown in the illustration. A small piece of high speed steel is then drawn out in wedge form and set into the pocket. The high speed steel wedge is firmly set in the pocket by a blow of the hammer and a thin strip of copper

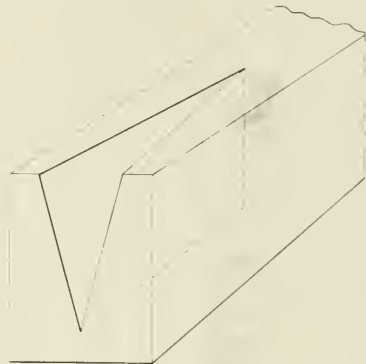

Tool Shank Ready for Piece of Inserted H. S. Steel

is placed on top, the whole being placed in the fire and allowed to heat. When the temperature is raised sufficiently, the copper fluxes and runs down between the wedge and the side of the V-shaped pocket, practically brazing the wedge in place. After cooling and grinding, this tool may be put to the most severe use on any heavy duty machine and will be found to give satisfactory service.

In practical operation tools made in this way at the Missouri Valley shops have been used on driving wheel lathes with good results. Not only does the tool stand up well under the work, but it is economical to use on account of the saving of small high speed steel bits which would otherwise be scrapped.

ELECTRIC WELDING FOR SHIPBUILDING.—A steel ship was recently launched in London which is the first to be constructed without rivets, the plates being welded together by the electric welding process.

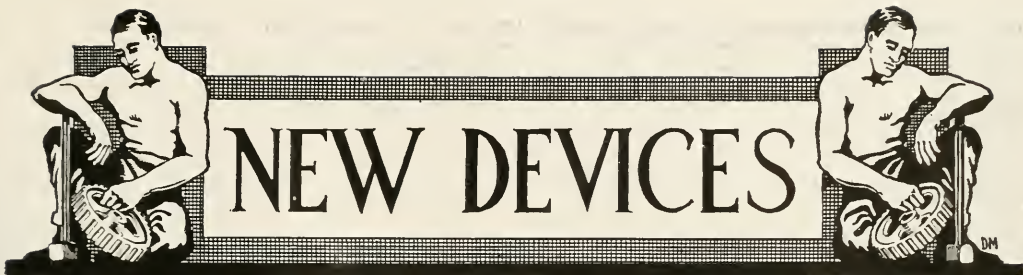

NEW DEVICES

A NEW CAR JACK

For about 20 years the Duff Manufacturing Company, Pittsburgh, Pa., has made the Barrett car jack No. 19. A new and improved model of this jack, known as the Duff No. 219, has recently been placed on the market. The best characteristics of the old jack have been retained and com-

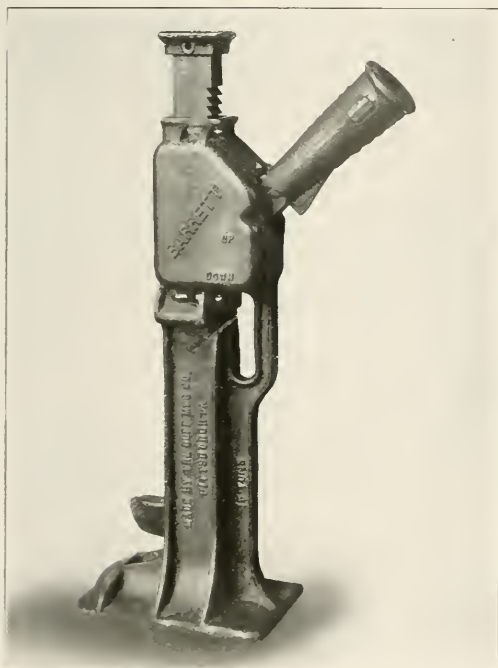

New Barrett Car Jack

lined with new and important improvements designed to reduce the wear and to increase the ease with which the jack is operated.

With the No. 219 jack it is possible to handle heavier equipment than with other plain ratchet jacks of equal capacity. This is due principally to the use of a fine tooth-lifting rack which decreases the amount of raise for each stroke of the lever and reduces the pressure required by about 30 per cent. Departing from the customary method of making the rack from the square section, the rack of this jack is made from a rectangular section, the thickness from

front to back being increased sufficiently to make allowance for the removal of metal in cutting the teeth. The double-pointed pawls distribute the lifting pressure evenly over two of the rack teeth so that each tooth bears only one-half of the load. When in mesh with the rack, the pawls occupy a true vertical position, eliminating side thrust, and reducing wear between the rack and the rack channel to a minimum. The socket lever is made of steel in one piece, the lower end containing the pawl bearing and the trunnion being case-hardened. The use of heavy fulcrum trunnions, cast integral with the socket lever, instead of the customary fulcrum pin, does away with the fulcrum pin-hole which weakens the



Operating Mechanism of Barrett Car Jack

socket lever at a point subject to heavy strain. Closed-end, refillable, grease-packed bushings are used in order to protect the trunnions against excessive wear by affording efficient lubrication.

The pawl bearing at the end of the socket lever is

shrouded, providing a guide at both sides and preventing excessive wear caused by sideways rocking of the pawl, as in socket levers having a center guide only. The jack frame is ribbed both front and back and the base plate has similar reinforcement.

The reversing mechanism is strong, simple and compact. Instead of an eccentric, a locking lever is used for shifting the position of the reversing lever. Pivoted on the reversing lever is the spring lever, to each end of which is attached a spring-controlled rod connecting with the two pawls. The cam lever is fastened firmly to the socket lever and operates the spring lever. There are no small or intricate parts to become lost or broken, and the entire mechanism can, if desired, be replaced as a unit.

Loss or breakage of the shield which covers the reversing mechanism will not affect the operation of the jack in any way.

The Duff No. 219 jack is single acting, 28 in. high, having a capacity of 15 tons and a raise of 17½ in. A similar jack, No. 339, is 6 in. shorter and has a correspondingly shorter raise.

A SELF-LOCKING CAR SEAL

A car seal of the self-locking type with no hidden parts has recently been developed by E. J. Brooks & Co., Inc., New York City. It consists of a single piece of steel wire, looped and flattened at one end, on which is stamped the name or the railroad, and flattened at the other end to receive the serial number.

The method of applying and locking the seal is clearly shown in the illustrations. After being properly inserted through the hasp lock of the car door the seal is locked by twisting the vertical end of the wire about the horizontal end near the flat loop. On the side of the vertical portion of the wire which comes on the inner or compression side of the twisted loop formed in locking the seal, is a series of nicks which insure that the seal may be locked without danger of

STEVENSON NUT LOCK

The most severe test that can be given any nut locking device is to use it at a busy railway crossing on rail and frog bolts. Such a test has been made of the Stevenson Permanent nut lock, manufactured by the Permanent Products Company, Cleveland, Ohio. The results of the test were satisfactory; for a period of a year, none of the bolts and nuts applied became loose. The illustration shows the arrangement of the Stevenson nut lock and its simple construction. The bolt has tapered grooves on opposite sides, the grooves being

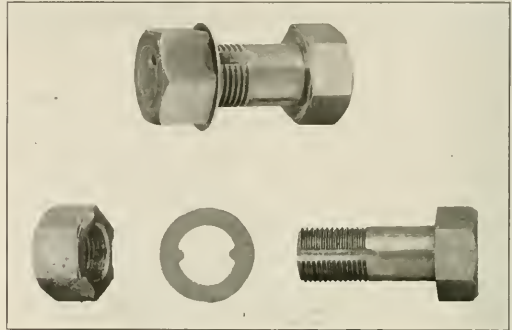

Stevenson Permanent Nut Lock.

deeper at the point of the bolt and gradually lessening in depth. The washer used has two inner extending lugs to fit the grooves on the bolt. The nut has recesses on three of its outer edges to receive the upset portion of the outer rim of the washer after the nut has been tightened.

The construction indicated insures the easy application of the washer to the bolt before applying the nut, as the

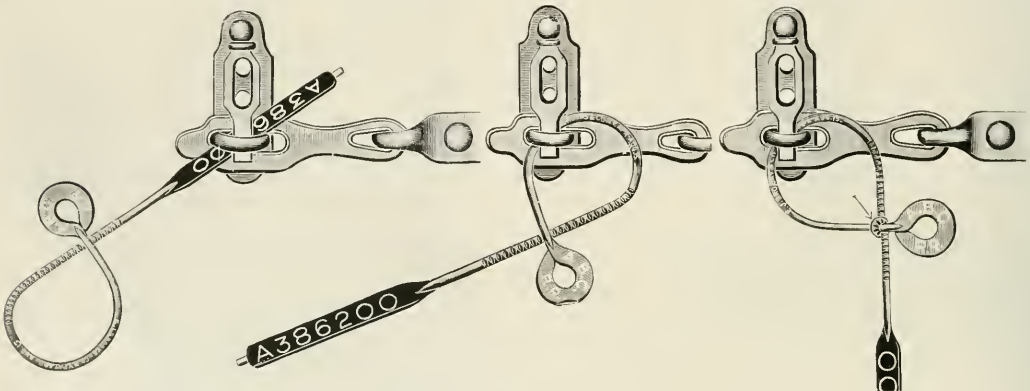

Brooks Twist-Lock Car Seal

breaking the wire. To unlock the seal this loop is simply untwisted and the nicked side of the wire is thereby brought into tension, which insures that the seal cannot be unlocked without breaking. A similar series of nicks is placed on the back side of the horizontal portion of the seal to prevent the possibility of successfully tampering with the seal should an attempt be made to lock it by twisting the horizontal portion of the wire about the vertical.

This seal has been in use on one of the eastern railroads for some time.

washer lugs do not begin to touch the base of the grooves on the bolt until the washer has passed on to the bolt about one-half the length of the tapered portion. When the washer is finally forced up against the work, it binds in the base of the grooves without engaging the threads. When the nut has been tightened sufficiently it is securely locked in position by upsetting the outer rim of the washer into one of the recesses on the nut. The nut may be removed with a wrench, but if the washer is to be used again, it is better to first straighten out the upset portion with a cape chisel.

Railway Mechanical Engineer

(Formerly the RAILWAY AGE GAZETTE, MECHANICAL EDITION
with which the AMERICAN ENGINEER was incorporated)

PUBLISHED ON THE FIRST THURSDAY OF EVERY MONTH BY THE
SIMMONS-BOARDMAN PUBLISHING COMPANY

EDWARD A. SIMMONS, *President* M. H. WIUM, *Secretary*
HENRY LEF, *Vice-President and Treasurer* L. B. SHERMAN, *Vice-President*
WOOLWORTH BUILDING, NEW YORK, N. Y.
F. H. THOMPSON, *Business Manager*, CHICAGO.

Chicago: Transportation Bldg. Cleveland: Citizens' Bldg.
Washington: Home Life Bldg.
London: Queen Anne's Chambers, Westminster.

ROY V. WRIGHT, *Editor*
R. E. THAYER, *Managing Editor*

C. B. PECK, *Associate Editor* E. L. WOODWARD, *Associate Editor*
A. F. STUBING, *Associate Editor* C. W. FOSS, *Associate Editor*

Entered at the Post Office at New York, N. Y., as mail matter of the second class.

Subscriptions payable in advance and postage free; United States, Canada and Mexico, \$2.00 a year; Foreign Countries, \$3.00 a year; Single Copy, 20 cents.

WE GUARANTEE, that of this issue 7,350 copies were printed; that of these 7,350 copies 6,103 were mailed to regular paid subscribers, 410 were provided for counter and news companies' sales, 192 were mailed to advertisers, 67 were mailed to employees and correspondents, and 578 were provided for new subscriptions, samples, copies lost in the mail and office use; that the total copies printed this year to date were 70,750, an average of 7,861 copies a month.

THE RAILWAY MECHANICAL ENGINEER is a member of the Associated Business Papers (A. B. P.) and of the Audit Bureau of Circulations (A. B. C.)

The use of anthracite by the railways of Canada must be reduced this coming winter by about 60 per cent. This is an order from the Canadian Railway War Board directing the roads to use no anthracite in stations or elsewhere, except in Baker heaters in passenger cars, when heat from the engine is unavailable. Ordinarily the Canadian roads would use nearly 100,000 tons of anthracite yearly.

In Circular No. 4-A, dated August 1, and superseding Circular No. 4, issued July 8, the executive committee of the Master Car Builders' Association gives the following instructions to members: When empty cars of 60,000 lb. capacity or over are placed on shop or repair tracks for repairs, they must not be returned to commercial service until they have been placed in condition to meet M. C. B. inspection without exceptions, including U. S. safety appliance requirements.

Under an order of the Fuel Administration, effective August 17, there may be added to the government mine price of coal delivered directly from mine tipples to locomotive tenders the sum of five cents a net ton, or such other sum as may be agreed upon between the operator and the railroad receiving the coal. In case of failure to agree the operator shall furnish such coal at the government mine price, plus such additional sum as may be fixed by the Bureau of Prices of the Fuel Administration.

The New York law (section 77 of chapter 649) requiring locomotives to have automatic fire doors and "vestibule" cabs applies to any locomotive operated by steam. The act will go into effect January 1, 1919, unless the director general or his representative shall otherwise direct. All new locomotives placed in service after the act takes effect must be equipped, and all existing locomotives must be so equipped the first time they are shopped for general repairs.

The National Research Council, acting as the Department of Science and Research of the Council of National Defense, has appointed a committee to investigate the fatigue phenomena of metals. H. F. Moore, professor of the engineering experiment station of the University of Illinois, is chairman. The committee is charged with the responsibility of developing a knowledge of the strength and durability of metals subjected to repeated stresses, such as ship structures, crank shafts of aircraft engines, and heavy ordnance. According to present plans the experimentation required will be done in the laboratories of the University of Illinois under the personal direction of Professor Moore.

Side Bearings for Standard Locomotives

In the issue of the *Railway Mechanical Engineer* for July it was stated that the orders for side bearings for the tenders of all the standard locomotives ordered by the Railroad Administration had been awarded to A. Stucki & Company. This order has since been changed and the "Tip-roller" side bearings made by Edwin S. Woods & Company, Chicago, have been specified instead. The awards for side bearings for the cars remain unchanged.

A Twenty-five Million Dollar Government Shop to Be Built in France

The importance of railroad guns is indicated by an announcement from the War Department that the chief of ordnance has approved plans for the manufacture of the machine tool equipment which the United States government will install in France for the relining of the heavy railroad guns in use by the American forces. The plans call for the expenditure of between \$25,000,000 and \$30,000,000, possibly more. The machine tools alone will cost between \$12,000,000 and \$15,000,000, and will consist of gunboring lathes, engine lathes, rilling machines and grinders.

A large number of these gun-boring lathes are designed for a 102-in. swing. To make these lathes, there is under construction at one of the machine tool factories in this country a giant planer 500 ft. long, costing \$450,000, and the lathes it will help make will approximate, in the aggregate, \$6,500,000.

The relining of guns is one of the important salvage operations in the war, saving time and money. Owing to the tremendous heat generated by the charge when the big guns are fired, their accuracy cannot be assured after a few hundred shots unless they are relined, notwithstanding the fact that all other parts except the lining are practically as good as new.

Recruiting Labor for Railroads

The railroads will not lose out in the campaign now going on to recruit unskilled labor for employers engaged in war work.

The Department of Labor in a statement issued last month said:

While the prohibition against recruiting of unskilled labor by employers engaged in war work, except under the direc-

tion of the Department of Labor, does not include railroads and farmers, the transportation and agricultural industries, will be assisted by the United States Employment Service in every way possible.

Specialization in farm and railroad labor supplying is a feature of the central labor recruiting program and the leading branch offices have special railroad labor and farm labor divisions, while in the west and in some places in the south and east, offices have been established which devote their entire attention to supplying farm labor and railroad unskilled labor. Recently the employment offices of railroads in western territory were made a part of the Federal Employment Service system.

This statement is made necessary by the existence of an erroneous belief that railroads and farms must obtain labor through means other than the United States Employment Service. The service will not only assist railroads and farms in getting unskilled labor, but they will be protected by the Department of Labor from recruiting by other industries.

Equipment Orders for Overseas Service

The United States Government has given an additional order for 500 Consolidation type locomotives to the Baldwin Locomotive Works, for service on the military railway lines in France.

The Railroad Administration's order for 15 additional locomotives from the Lima Locomotive Corporation, reported last month, is for light Mikado locomotives.

It is understood that orders for 10,000 cars for the use of General Pershing's forces will be distributed as follows: American Car & Foundry Company, 2,400; Standard Steel Car Company, 1,900; Haskell & Barker, 1,800; Pressed Steel Car Company, 1,500; The Pullman Company, 1,500; Standard Car Construction Company, 400 tank cars; Liberty Car Company, 250; St. Louis Car Company, 250; all but the 400 tank cars are box cars and gondolas.

Changes in M. C. B. Interchange and Loading Rules

The executive committee of the Master Car Builders' Association has recently issued Circular No. 6 supplementing the 1917 loading rules. This circular contains modifications of rules 17, 56, 57 and 59 and also the following new rules: Rule 88 covering the manner of loading metal plates in gondola cars; Rule 112-C on loading wrought iron pipe 12 in. or less on flat cars; Rule 117-B on the manner of securing concrete culvert pipe loaded on flat cars, and Rule 125 on the manner of loading metal sheets in box cars.

Circular No. 9 announces the extension of the date effective of paragraphs d, f, h, and i of Rule No. 3 to October 1, 1920, and the elimination of paragraph k of Rule 3, effective July 15, 1918.

The executive committee has also issued the following circular relating to the defect carding of cars offered in interchange: "The M. C. B. rules in reference to defect carding of cars in interchange are modified as follows: (a) Defect carding for any delivering line defects, as between govern-

ment controlled roads for defects on cars belonging to non-government controlled roads and private car lines as well as cars belonging to government controlled roads is discontinued. (b) Defect carding for any delivering line defects on cars belonging to non-government controlled roads and private car lines is limited to the first and last government controlled road receiving or delivering the car."

MEETINGS AND CONVENTIONS

Meeting to Discuss Fuel Economy in Stationary Plants.—A meeting has been called by Eugene McAuliffe, manager Fuel Conservation Section, Division of Operation, United States Railroad Administration, of one delegate from each railroad operating 500 or more miles of line for the purpose of discussing fuel conservation in stationary plants. The meeting is to be held at the Dearborn Hotel, Chicago, at 9:30 a. m., on Monday, September 9. The delegates are to be selected with regard to their direct responsibility for fuel consumption on other than locomotives. The mechanical engineering staff of the United States Fuel Administration, Department of Conservation, headed by David Moffet Myers, will attend the meeting, and deliver a series of short, concise addresses on the proper maintenance and operation of stationary plants. There is a great opportunity of saving fuel along these lines. In 1918 the railroads consumed in this manner approximately 16 million tons of coal costing about \$56,000,000. The meeting will last only one day and is held a day before the Traveling Engineers' Association convenes in order that the men attending may have an opportunity to attend that convention.

The following list gives names of secretaries, dates of next or regular meetings and places of meeting of mechanical associations:

- AIR BRAKE ASSOCIATION.—F. M. Nellis, Room 3014, 165 Broadway, New York City.
- AMERICAN RAILROAD MASTER TINNERS', COPPERSMITHS' AND PIPEFITTERS' ASSOCIATION.—O. E. Schlink, 485 W. Fifth St., Peru, Ind.
- AMERICAN RAILWAY MASTER MECHANICS' ASSOCIATION.—V. R. Hawthorne, 746 Transportation Bldg., Chicago.
- AMERICAN RAILWAY TOOL FOREMEN'S ASSOCIATION.—R. D. Fletcher, Belt Railway, Chicago.
- AMERICAN SOCIETY FOR TESTING MATERIALS.—C. L. Warwick, University of Pennsylvania, Philadelphia, Pa.
- AMERICAN SOCIETY OF MECHANICAL ENGINEERS.—Calvin W. Rice, 29 W. Thirty-ninth St., New York.
- ASSOCIATION OF RAILWAY ELECTRICAL ENGINEERS.—Joseph A. Andreucetti, C. & N. W., Room 411, C. & N. W. Station, Chicago.
- CAR FOREMEN'S ASSOCIATION OF CHICAGO.—Aron Kline, 841 Lawlor Ave., Chicago. Meetings second Monday in month, except June, July and August, Hotel Morrison, Chicago.
- CHIEF INTERCHANGE CAR INSPECTORS' AND CAR FOREMEN'S ASSOCIATION.—W. R. McMunn, New York Central, Albany, N. Y.
- INTERNATIONAL RAILROAD MASTER BLACKSMITHS' ASSOCIATION.—A. L. Woodworth, C. H. & D. Lima, Ohio.
- INTERNATIONAL RAILWAY FUEL ASSOCIATION.—J. G. Crawford, 542 W. Jackson Blvd., Chicago.
- INTERNATIONAL RAILWAY GENERAL FOREMEN'S ASSOCIATION.—William Hall, 1061 W. Wabash, Winona, Minn.
- MASTER BOILERMAKERS' ASSOCIATION.—Harry D. Vought, 95 Liberty St., New York.
- MASTER CAR BUILDERS' ASSOCIATION.—V. R. Hawthorne, 746 Transportation Bldg., Chicago.
- MASTER CAR AND LOCOMOTIVE PAINTERS' ASSOCIATION OF U. S. AND CANADA.—A. P. Dane, B. & M., Reading, Mass.
- NIAGARA FRONTIER CAR MEN'S ASSOCIATION.—George A. J. Hochgrebe, 623 Brisbane Bldg., Buffalo, N. Y. Meetings, third Wednesday in month, Stabler Hotel, Buffalo, N. Y.
- RAILWAY STOREKEEPERS' ASSOCIATION.—J. P. Murphy, Box C, Collinwood, Ohio.
- TRAVELING ENGINEERS' ASSOCIATION.—W. O. Thompson, N. Y. C. R. R., Cleveland, Ohio. Next meeting, September 10, 1918, Chicago.

RAILROAD CLUB MEETINGS

Club	Next Meeting	Title of Paper	Author	Secretary	Address
Canadian	Sept. 10, 1918	James Powell.....	P. O. Box 7, St. Lambert, Que.
Central	Sept. 13, 1918	Educating Road Foremen, Engineers and Firemen	F. J. Barry.....	Harry D. Vought.....	95 Liberty St., New York.
Cincinnati	Nov. 12, 1918	Annual Meeting	H. Boutet.....	101 Carew Bldg., Cincinnati, Ohio.
New England	Oct. 8, 1918	W. E. Cade, Jr.....	683 Atlantic Ave., Boston, Mass.
New York.....	Sept. 20, 1918	Architecture and Erection of Notable Bridges	C. E. Fowler.....	Harry D. Vought.....	95 Liberty St., New York.
Pittsburgh	M. J. Hepburn.....	102 Penn. Station, Pittsburgh, Pa.
St. Louis.....	B. W. Frauchenthal.....	Union Station, St. Louis, Mo.
Western

PERSONAL MENTION

FEDERAL ADMINISTRATION APPOINTMENTS

A. F. DUFFY has been appointed assistant manager of the Safety Section, Division of Operation, of the United States Railroad Administration, with office at Washington, D. C., succeeding W. P. Borland, who is now chief of the Bureau of Safety, Interstate Commerce Commission.

GEORGE N. DE GUIRE has been appointed general supervisor of equipment for eastern territory, on the staff of the mechanical assistant to the director of the division of operation.

JOHN McMANAMY has been appointed general supervisor of equipment for western territory, on the staff of the mechanical assistant to the director of the division of operation, with headquarters at Washington, D. C.

F. P. PFAHLER, mechanical engineer of the locomotive section, has been made chief mechanical engineer on the staff of the mechanical assistant to the director of the division of operation.

J. J. TATUM, manager of the car repair section, United States Railroad Administration, has had his title changed to general supervisor of car repairs.

FRANK J. WHITEMAN, superintendent of safety of the St. Louis-San Francisco, has resigned and has been appointed supervisor of safety for the Southwestern Region, with headquarters at St. Louis.

GENERAL

GUY J. CONGDON has been appointed supervisor of fuel of the Chicago Great Western, with headquarters at Chicago. Mr. Congdon had been previously employed in the perishable freight department of the Illinois Central, at Chicago.

HARRY K. FOX, whose appointment as mechanical engineer of the Chicago, Milwaukee & St. Paul, with headquarters at Chicago, was announced in the *Railway Mechanical Engineer* for August, was born in Washington county, Maryland, on October 14, 1881. Mr. Fox was educated in the Washington County Academy, graduating in 1900. In September, six years later, he began his railroad career, entering the service of the Norfolk & Western, at Roanoke, Va., with which company he remained for about three years, following which he entered the employ of the Pennsylvania Railroad, at Pittsburgh, where he remained until November, 1911, when he became drafts-



H. K. Fox

man on the Western Maryland, at Hagerstown, Md. In October, two years later, he was promoted to motive power inspector, and in October, 1916, he became chief draftsman. On March 8, 1918, Mr. Fox was appointed engineer of tests of the Chicago, Milwaukee & St. Paul, at Milwaukee, Wis.,

which position he held until his promotion to mechanical engineer on July 8.

H. C. EICH, superintendent of motive power of the Chicago Great Western, at Oelwein, Iowa, has been appointed general superintendent of machinery, with the same headquarters. A photograph of Mr. Eich and a sketch of his career were published in the November issue of the *Railway Mechanical Engineer* on page 656.

W. A. MCGEE has been appointed mechanical engineer of the New York Central, lines west of Buffalo, with headquarters at Cleveland, Ohio, succeeding M. V. Bailliere, resigned.

JACOB EDGAR MECHLING, whose promotion to superintendent of motive power of the Pennsylvania System, western lines, was announced in the August issue, was born



J. E. Mechling

at Butler, Pa., on November 29, 1863. Mr. Mechling was educated in the high school in his native town and in 1880 he entered the employ of the H. K. Porter Locomotive Works at Pittsburgh, Pa., as a machinist apprentice. In April, 1882, he entered the service of the Pennsylvania Railroad at Pittsburgh, as special apprentice. The following year and until May, 1886, he was employed by the Chicago, Milwaukee & St. Paul, following which he returned to the service of the Pennsylvania. Three months later he was promoted to gang foreman of the erecting shop at Pittsburgh, and subsequently became assistant foreman at the shop where he was first employed. Later he was made foreman of the new enginehouse at Wall, Pa., where he remained until May, 1902, at which time he was promoted to assistant master mechanic of the Pittsburgh division, with headquarters at Pittsburgh. Two years later he was promoted to master mechanic of the Vandalia, with headquarters at Terre Haute, Ind., which position he held until his appointment as superintendent of motive power as mentioned above.

D. J. MULLEN, superintendent motive power of the Cleveland, Cincinnati, Chicago & St. Louis, with headquarters in Indianapolis, Ind., has had his authority extended over the Chesapeake & Ohio of Indiana.

F. K. MURPHY, assistant superintendent motive power of the Cleveland, Cincinnati, Chicago & St. Louis, also has authority now over the Chesapeake & Ohio of Indiana. His headquarters are in Indianapolis, Ind.

A. P. PRENDERGAST, mechanical superintendent of the Texas & Pacific at Dallas, Tex., has been appointed also mechanical superintendent of the Louisiana Railway & Navigation Company (lines west of Mississippi river) and the Trans-Mississippi Terminal. Mr. Prendergast's headquarters are at Dallas.

W. H. SAMPLE, superintendent of motive power of the Grand Trunk, at Montreal, Que., has been transferred to the western lines, with headquarters at Detroit, Mich., effective August 26.

W. J. TAPP has been appointed fuel supervisor of the

of the

Denver & Rio Grande, with headquarters at Denver, Colo., effective August 19.

F. W. TAYLOR has been appointed mechanical superintendent of the Missouri, Kansas & Texas of Texas; the Wichita Falls & North Western; the Fort Worth & Denver City; the Wichita Valley; the Houston & Texas Central; the Union Terminal of Dallas, and the Abilene & Southern, with office at Dennison, Texas.

L. H. TURNER, superintendent motive power of the Pittsburgh & Lake Erie, has been appointed superintendent motive power also of the Lake Erie & Eastern and the Monongahela Railway, with office at Pittsburgh, Pa.

B. L. WHEATLEY, master mechanic of the Chicago, Rock Island & Pacific and the Chicago, Rock Island & Gulf, with office at Fort Worth, Texas, has been appointed superintendent of fuel economy of the same roads, with headquarters at Chicago, succeeding H. Clewer, appointed supervisor of the fuel conservation section of the Pocahontas region.

OSCAR E. WOLDEN, assistant fuel supervisor of the Minneapolis, St. Paul & Sault Ste. Marie, at Minneapolis, Minn., has been appointed acting supervisor, succeeding L. R. Pyle, now on the staff of the Central Western regional director.

MASTER MECHANICS AND ROAD FOREMEN OF ENGINES

J. J. CAREY, general master mechanic of the Texas & Pacific at Dallas, Texas, has also been appointed general master mechanic of the Louisiana Railway & Navigation Company (lines west of the Mississippi river) and the Trans-Mississippi Terminal, with the same headquarters.

A. J. DAVIS, master mechanic of the Erie at Hornell, N. Y., has been transferred to the New York division and side lines, having charge of passenger equipment, succeeding F. H. Murray, promoted. His headquarters are in Jersey City, N. J.

M. A. GLEESON, general foreman, locomotive department, of the Baltimore & Ohio, with office at New Castle Junction, Pa., has been appointed master mechanic of the New Castle division, with office at New Castle Junction, succeeding A. H. Hodges, transferred.

WILLIAM E. HARMISON, assistant master mechanic of the Mahoning division of the Erie, has been appointed master mechanic, with headquarters at Kent, Ohio, succeeding William Moore.

LEE R. LAIZURE, shop superintendent of the Erie at Hornell, N. Y., has been appointed master mechanic of the New York division and side lines, in charge of freight equipment, with headquarters in Secaucus, N. J. He succeeds Thomas S. Davey, transferred.

WILLIAM MOORE, master mechanic of the Erie at Kent, Ohio, has been transferred as master mechanic to the Susquehanna, Tioga and Jefferson divisions, with headquarters at Susquehanna, Pa., succeeding Clarence H. Norton, transferred.

RALPH R. MUNN has been appointed assistant master mechanic of the Mahoning division of the Erie, with headquarters at Brier Hill (Youngstown), Ohio, succeeding William E. Harmison.

WILLIAM F. MURRAY has been appointed master mechanic of the New Jersey Southern division of the Central of New Jersey, with office at Lakehurst, N. J., to succeed William Montgomery, retired.

CLARENCE H. NORTON, master mechanic of the Susquehanna, Tioga and Jefferson divisions of the Erie, has been transferred to the Allegheny and Bradford divisions, with headquarters at Hornell, N. Y., succeeding A. J. Davis.

CAR DEPARTMENT

A. E. CALKINS, assistant superintendent of rolling stock of the New York Central Lines East, has been appointed engineer of rolling stock of the New York Central Lines, with office at New York. Mr. Calkins is in the service of the corporation, and is not in the operating organization.

I. S. DOWNING, general master car builder of the Cleveland, Cincinnati, Chicago & St. Louis, with headquarters at Indianapolis, Ind., has had his authority extended over the Chesapeake & Ohio of Indiana.

W. R. MCMUNN, general car inspector of the New York Central, Buffalo and east, with office in Albany, N. Y., has been appointed assistant to the superintendent of rolling stock, with office in New York, succeeding A. E. Calkins.

HARRY W. MAURER has been appointed assistant superintendent of the car department of the Minneapolis, St. Paul & Sault Ste. Marie, with office at Minneapolis, Minn.

SHOP AND ENGINEHOUSE

JOHN BURNS, master mechanic of the Quebec district of the Canadian Pacific, at Montreal, Que., has been appointed assistant works manager of the Angus shops at Montreal, succeeding J. W. Buckland, granted leave of absence.

THOMAS S. DAVEY, master mechanic of the Erie at Secaucus, N. J., has been appointed shop superintendent at Hornell, N. Y., succeeding Lee R. Laizure.

S. G. KENNEDY, shop foreman of the Atlantic Coast Line, with office at Sanford, Fla., has been appointed general foreman at Lakeland (Fla.) shops, vice G. F. Richards, resigned.

PURCHASING AND STOREKEEPING

J. W. GERBER, general storekeeper of the Southern Railway, with office at Washington, D. C., has been appointed general storekeeper also of the Alabama & Vicksburg, the Carolina, Clinchfield & Ohio, the Carolina, Clinchfield & Ohio of South Carolina, the Georgia Southern & Florida, and the St. Johns River Terminal, with headquarters at Washington, D. C.

RALPH P. MOORE, purchasing agent of the Duluth & Iron Range, has been appointed purchasing agent of that road and the Duluth, Missabe & Northern, succeeding on the latter road H. Greenfield, with office at Duluth, Minn.

COMMISSION APPOINTMENT

W. J. PATTERSON has been appointed assistant chief of the Bureau of Safety, Interstate Commerce Commission, with office at Washington, D. C. Mr. Patterson has been an inspector of safety appliances under the commission for the past four years.

OBITUARY

C. W. VAN BUREN, general master car builder of the Canadian Pacific was killed in an automobile accident near Albany, New York, on August 25.

NEW SHOPS

HOCKING VALLEY.—This road has given a contract to the Austin Company, Cleveland, Ohio, for the erection of a 10-stall roundhouse at Nelsonville, Ohio, to be completed in 75 working days.

PHILADELPHIA & READING.—A contract has been given to D. S. Warfel, Lancaster, Pa., for putting up a new machine shop at Rutherford, Pa. The building is to be a one-story structure, 20 ft. wide by 158 ft. long, of brick construction on concrete foundation and base, with steel frame roof and steel sash.

SUPPLY TRADE NOTES

John F. Long, assistant to president, Bruce V. Crandall Service, has received a commission as captain in the engineer corps.

The Toronto office of the Metal & Thermit Corporation has been moved from 103 Richmond street, S. W., to 15 Emily street.

Sylvanus L. Schoonmaker, chairman of the board of directors of the American Locomotive Company, died on August 17 at his summer home at Locust Valley, L. I.

Marshall E. Keig, secretary and treasurer of Harry Vissering & Co., secretary and treasurer of the Okadee Company, and third vice-president of the Charles R. Long, Jr., Company, with office at Chicago, has resigned from those positions and has been given a leave of absence for the period of the war. Mr. Keig has been accepted for service in the signal corps of the army after having been rejected from the artillery, infantry, marines, railroad regiments and navy on account of defective vision. Before entering the railway supply field, Mr. Keig was employed by the Atchison, Topeka & Santa Fe. From 1904 until 1907 he was in the construction and operating departments and in the ensuing five years was in the general purchasing department at Chicago. He has been with the supply companies which he now leaves ever since severing his connection with the Santa Fe.

The Q. & C. Company, New York, opened an office in the Claus Spreckels building, San Francisco, Cal., on August 21. This office is in charge of Latham McMullin.

R. S. Brown, who has been with the G. M. Basford Company, New York, since its establishment, two years ago, was made vice-president of that company August 26.

L. R. Boyer, formerly with the United States Bureau of Standards, has entered the service of E. & T. Fairbanks & Co., scale manufacturers, with headquarters at St. Johnsbury, Vt.

The Thomas A. Edison, Inc., primary battery division, has moved its San Francisco office from room 921 Crocker building to room 1205 Hobart building. E. W. Newcomb is in charge.

The Edison Storage Battery Supply Company has moved its New Orleans office from 201 Baronne street to larger and more commodious quarters in the Maison Blanche building, room 911.

H. K. Christie, air brake inspector and instructor of the Pere Marquette, with headquarters at Grand Rapids, Mich., has left the service of that company to enter advertising work with a Chicago agency.

E. R. Wood, formerly eastern representative of the High Speed Hammer Company, Rochester, N. Y., has associated

himself with the sales department of the Sherritt & Stoer Company, Inc., Philadelphia, Pa.

The Chicago Pneumatic Tool Company announces the appointment of C. W. Cross as special representative for the sale of pneumatic tools to railroads, succeeding L. C. Sprague, who has been made district manager of sales at New York.

At the last meeting of the board of directors, Le Grand Parish, chairman of the executive committee, was elected president of the Lima Locomotive Works, Inc. Mr. Parish will also retain the presidency of the American Arch Company.

W. H. V. Rosing, formerly in the employ of the St. Louis-San Francisco, has become associated with the Globe Seamless Steel Tubes Company of Milwaukee, Wis., as assistant mill manager in charge of the engineering and mechanical departments.

The Chicago Pneumatic Tool Company has started work on the construction of an addition to the Cleveland plant, which is planned to double the present output. It is expected that work will be completed on the building about November 1. The necessary equipment has been ordered.

H. E. Chilcoat, representative of the Westinghouse Air Brake Company at its Pittsburgh office, has severed his connection with that company to accept the position of manager of the Clark Car Company, Pittsburgh, manufacturers of the Clark extension side dump car.

The Independent Pneumatic Tool Company has leased the entire sixth floor of the Otis building at 600 West Jackson Boulevard, Chicago, for general offices, and removal was effected about September 1. The new quarters are twice as large as those formerly occupied at 1307 South Michigan avenue.

A. G. Delany, salesman for the American Brake Shoe & Foundry Company, with headquarters at Chicago, has been appointed local manager of that company, at Minneapolis, Minn., where he will have charge of its work and will also look after sales in northwestern territory. Mr. Delany was born at Worcester, N. Y., in 1879. In 1896 he entered the service of the Chicago, Burlington & Quincy as an office boy; later he served for a period of seven years in the Burlington locomotive shops at Chicago, and at Aurora, Ill., following which he was appointed mechanical traveling inspector, having charge of the heating and lighting of passenger cars of both the east and west lines. In 1905 he resigned to become salesman for the Safety Car Heating & Lighting Company, at Chicago, where he remained for three years, following which he went with the Chicago Car Heating Company, as salesman, with headquarters at Atlanta, Ga. In 1911 he left that company to become salesman for American Brake Shoe & Foundry Company, at Chicago, which position he held until his recent appointment as local manager at Minneapolis.

The Bird-Archer Company, manufacturer of locomotive boiler chemicals, has moved its Chicago offices to 1105 Peoples Gas building, the change having been necessitated



M. E. Keig



A. G. Delany

by larger space requirements. This company has recently increased its manufacturing facilities by opening a new factory in Chicago, and a new factory at Cobourg, Ont., besides materially increasing the output of its Philadelphia factory.

George H. Musgrave was appointed general manager of the Star Brass Manufacturing Company, Boston, Mass., on July 1. Mr. Musgrave has been with this company for more than 30 years, having left the service of the New York & New England Railroad to go to the Star Brass Manufacturing Company. In 1900 he was appointed general sales agent, specializing on railway, marine and naval steam devices.

The Lagonda Manufacturing Company, Springfield, Ohio, announces that the Syracuse (N. Y.) district office in charge of T. X. Lieb, has been moved from 2400 South Salina street to 219 Union Bank building, and that the Cincinnati branch office has been moved from the First National Bank building to 2607 Union Central building. Frank Walmsley, who has handled the Lagonda business in Cincinnati for some time, is in charge.

Press G. Kennett, western railroad sales manager of the Flint Varnish & Color Works, with headquarters at Chicago, has resigned to become manager of the railroad department of the C. R. Cook Paint & Varnish Company, Kansas City, Mo. Mr. Kennett was connected with the Flint Varnish & Color Works for eight years and previous to that had 17 years of railroad experience in the stores and purchasing departments of several lines in the Southwest.

Wilberforce Eckels, who for five years has been assistant western sales manager of the Standard Coupler Company in Chicago, has been commissioned a second lieutenant of engineers. Mr. Eckels is a graduate of Pennsylvania State College, where he took a mechanical engineering course. Owing to the fact that George A. Post, Jr., formerly western sales manager, has been for several months a captain in the ordnance corps, and that now Lieutenant Eckels is also in military service, the company has closed its Chicago office.

The Dearborn Chemical Company, Chicago, announces the inauguration of a specialties department for the manufacture and marketing of a number of specialties of interest to manufacturers of steel products. These specialties have been tested in actual service for two years or more and include a rust preventive known as No-Ox-Id, cutting oils for lubricating the cutting tool and preventing overheating in metal cutting, quenching oils for heat treating, drawing oils, and Dearboline, a preparation for cleaning machined parts of emery or grease.

W. J. Schlacks, vice-president and director of McCord & Co., at Chicago, has incorporated the Locomotive Lubricator Company and has purchased the McCord locomotive lubricator. The new company will manufacture and promote the sale of the Schlacks system of locomotive forced feed lubrication. O. H. Neal and C. W. Rudolph, sales engineers, who have been associated with Mr. Schlacks in McCord & Co., have joined the new company, now located in the Tower building, Chicago. Mr. Schlacks' photograph and biographical sketch appeared in the December, 1917, issue.

The Westinghouse Electric & Manufacturing Company has purchased the property, business and good-will of the Krantz Manufacturing Company, Inc., Brooklyn, N. Y., manufacturers of safety and semi-safety electrical and other devices, such as auto-lock switches, distribution panels, switchboards, floor boxes, bushings, etc. The supply department of the Westinghouse Electric & Manufacturing Company will act as exclusive sales agent for the products of the Krantz Manufacturing Company, Inc., Brooklyn, N. Y., continued under its present name. H. G. Hoke, of the Westinghouse Electric & Manufacturing Company, will represent the supply department at the Krantz factory.

CATALOGUES

TANKS.—The Walter A. Zelnicker Supply Company, St. Louis, Mo., has issued bulletin No. 246. This is a four-page pamphlet and contains specifications for some of the storage, wooden and car tanks, etc., carried in stock by the company.

EXPANSION JOINTS.—The Ross Heater & Manufacturing Company, Buffalo, N. Y., has issued a folder describing and illustrating the Ross crosshead-guided expansion joints, water heaters, condensers and other apparatus manufactured by this company.

STROM BEARINGS.—Data sheets giving prices and dimensions of all types of Strom bearings have been compiled in a 72-page catalogue by the U. S. Ball Bearing Manufacturing Company of Chicago, to assist purchasers in making selection of the proper bearings for their needs.

FLEXIBLE SHAFT COUPLINGS.—Bulletin No. 26 of the Smith-Serrell Company, Inc., 90 West street, New York, issued recently, describes the construction and operation of Francke flexible shaft couplings of the heavy pattern type. Directions are given for size selection and installation.

PISTON RINGS.—Ever-Tight piston rings, which are claimed to increase compression and power and reduce waste of fuel and oil, are described and illustrated in a four-page folder issued by the Ever Tight Piston Ring Company, St. Louis, Mo. The dimensions are given in the pamphlet.

CALCULATING BEARING LOADS.—The U. S. Ball Bearing Manufacturing Company has compiled in a booklet of convenient size, formulae and calculations necessary to determine the loads on ball bearings resulting from various types of power transmitting elements, with sketches illustrating the various bearing loads. These include belt, rope and chain drive loads, spur, helical and bevel gear drive loads, and helical bevel gear and worm gear drive loads.

PORTABLE FORGES.—The Buffalo Forge Company, Buffalo, N. Y., has issued a catalogue entitled Buffalo Forges, describing the complete line of portable machines manufactured by that company. In order to simplify the catalogue and make changes and additions easy, it has been punched and the new sections may be attached by suitable brass fasteners. Section No. 108 has recently been issued, to be added in this way. It covers the line of stationary forges manufactured by the company.

THE LUBRICATION OF BALL BEARINGS.—The United States Ball Bearing Manufacturing Company, Chicago, has reprinted in an attractive booklet, an article published in the American Machinist of February 21, 1918, by Otto Bruenauer, director of sales and engineering of the company. Methods of determining the best lubricants to use are described, as well as the proper housing of ball bearings. The text is well illustrated with sketches showing ways of sealing the bearings from dirt and water.

ELECTRIC SOLDERING IRONS.—The Cutler-Hammer Manufacturing Company of Milwaukee, Wis., and New York, has issued an eight-page folder describing and illustrating the C-H electric soldering irons and hand tools. Two views are shown of the soldering iron, which has a threaded heating core over which the tip is screwed, and a new automatic rack is explained in detail. A six-inch current regulating plate which provides temperature control where different grades of work are being done, and the C-H 7050 feed-through switch for installation on the heater cord, are also illustrated.

Railway Mechanical Engineer

Volume 92

October, 1918

No. 10

CONTENTS

EDITORIALS

Subscribe in 100 Per Cent Amounts.....	539
There Is No Place on Railroads for Slackers.....	539
Fuel Conservation in Stationary Plants.....	540
Box Car Doors Need Attention.....	540
Save Paper Is the Order of the Day.....	540
The Traveling Engineers' Convention.....	540
Last Call to Prepare for Winter.....	541
Watch Fuel Consumption of Stoker Locomotives.....	541
Are You Prepared for Blizzards?.....	541
New Books.....	541

GENERAL

Organize for the Liberty Loan.....	542
First Standard 0-3-0 Switcher.....	543
Farther Increase in Wages to Mechanical Department Men.....	545
Traveling Engineers' Convention.....	547
Address by President Feeny.....	547
Address by Frank McManamy.....	548
The Railways in the War.....	549
Railway Fuel Conservation.....	550
Mr. Quayle's Address.....	552
How Can the Traveling Engineers Best Aid in the Maintenance of Locomotives?.....	552
Co-operation of Traveling Engineers and General Air Brake Inspectors.....	553
Other Business.....	555
List of Exhibitors.....	555
Fuel Economy at Stationary Plants.....	556
Railroad Administration Activities.....	558

CAR DEPARTMENT

U. S. R. A. Standard Baggage Cars.....	561
Cash Cleaners' Wages.....	564
Draft Gears should Be Maintained.....	565
The Journal Box Packing Situation.....	567
Maintenance of Air Brakes.....	568
Heavy Freight Cars for a Narrow Gage Railway in India.....	569

SHOP PRACTICE

Reclaiming Top Heads of Westinghouse 9 $\frac{1}{2}$ -in. Air Compressors.....	571
Oxy-Acetylene and Electric Welding.....	571
Time Saved by Paint Spraying Machines.....	572
Machining Locomotive Driving Boxes.....	573
Manufacturing Scrap Iron Into Locomotive Parts.....	576
Form for Babbitting Crosshead Shoes.....	576
New Devices in Saw Wheel Shop.....	577
Enginehouse Trolley Hoist.....	579
Setting Eccentrics Before Engines Are Wheeled.....	580
Rattler for Flexible Staybolt Caps.....	580

NEW DEVICES

Steam Heat End Valve with Automatic Drip.....	581
Forged Superheater Return Bends.....	581
Joliet Journal Box.....	582
Tight Rivets.....	582

GENERAL NEWS

Notes.....	583
Personal Mention.....	584
Supply Trade Notes.....	587

Subscribe in 100 Per Cent Amounts

“One hundred per cent subscriptions and one hundred per cent amounts.” That is the goal toward which railwaymen must work in the Fourth Liberty Loan campaign. The country must raise between September 28 and October 19, \$6,000,000,000 in 4 $\frac{1}{4}$ per cent Liberty Bonds, double the amount that was raised in the Third Campaign. Railwaymen will play a big part in the present drive. They are being given a chance to subscribe on a partial payment plan, whereby payments may be deducted from their salaries in eight monthly installments, the eight months' period not beginning, in the case of those who are still paying on their Third Loan Bonds, until the first of the year. There are general committees, terminal committees, office committees, division committees, shop committees through which every man in railway service will be reached and asked to take a bond. There is every hope that every man will subscribe—thereby making a perfect record of 100 per cent subscriptions. But that will not be enough. In the first loan railwaymen subscribed creditably, in the second loan they doubled their totals in the first loan, and in the third loan they considerably more than doubled their totals in the second loan. Are they going to double their third loan totals in the fourth loan? They can and must, to keep up their most enviable record. Bear these facts in mind when you subscribe and tell your men when you ask them to subscribe. Liberty Bonds are the best securities in the world! To show what you think of the Hun who hits below the belt, who sinks hospital ships, who bombs hospitals, who destroys places of worship, who murders women and children, who cries “Kamerad!” and then shoots and stabs,

who—but why go on with the endless list—**YOU WILL SUBSCRIBE!** And to show your respect for those brave Yanks who have gone over there to stop these things you will do more—you will lend the way our soldiers fight—you will buy Liberty Bonds to your **UTMOST!**

There Is No Place on Railroads for Slackers

The regional director for the Pochontas region has issued a circular to all employees with the statement, “Slackers have no place in this region,” and calls attention to the fact that the responsibilities of railroad employees under federal control have changed only in that they have been increased. This message should be carried from one end of the country to the other. There will be a very strong tendency on the part of some of the men to take advantage of the increase in wages with the accumulated back pay in treating themselves to a “good” vacation. The mechanical department employee particularly, while he is getting more money, is duty bound to work to his utmost. At the present time this nation is “Jong” on money and “short” on time and production. The mechanic is in greater demand than ever before in the history of this country. He is receiving higher wages than were even dreamed of two years ago. It is no time for him to lay down on the job. He must come across and deliver the goods as every “dough-boy” is compelled to do on his \$30 a month. It is easy for a man to say, “A couple of days off this week will never be felt,” but as the many hundreds of thousands of \$50 Liberty Bonds have gone to make our Liberty Loans a success, just so that man's couple of days will contribute to make this na-

tion's efforts a success. Tie the work of the men at home to the work of the boys in the trenches. Get every one to realize how much depends upon his own individual effort. If this is done, it will be possible to make the message of the regional director to his men read, "There are no slackers in this region."

Fuel Conservation in Stationary Plants

With the nation facing a fuel shortage of approximately 75,000,000 tons of bituminous coal this year, with the increasing demands of the war industries for fuel with which to generate power to manufacture the war supplies, and with the increasing demands for fuel by our allies, it behooves every railroad man to do his utmost to conserve fuel. The Fuel Conservation Section of the Railroad Administration, appreciating the conditions in the stationary plants on American railways, is making a hard drive in this field. At a meeting of railway men responsible for fuel used on other than locomotives, held in Chicago during the month and which is reported elsewhere in this issue, several concrete suggestions were made for saving fuel. The railroads use such a vast quantity of fuel and it appears to be so plentiful, that it takes considerable mental effort for one to make himself realize the necessity for saving. The various ramifications of fuel economy have been overlooked. In the past but few have looked upon a leaky air line as a fuel waster. But few have thought of lagging steam pipes in an endeavor to save fuel. Very few have considered what wasted power, unnecessary lights, improperly maintained buildings, poor boiler installations and the like mean to the coal pile. The real effort will be in getting everyone to realize how important it is to consider *all* of these things. The conditions are such that expenditures which in the past were believed to be unwarranted must be made in order to save fuel. We must no longer look upon fuel as worth so much money, but we must consider it from the standpoint of what it will do to increase our productiveness and thus helping to win the war.

Box Car Doors Need Attention

No one who observes the condition of freight equipment can fail to notice the large per cent of box cars with defective side doors that are now in service. From the standpoint of the car repair foreman this is a minor matter, as door repairs are not difficult to make and do not involve much expense. From the shippers' viewpoint, however, this is a serious defect, as there are very few commodities shipped in box cars which do not require good door protection.

The reinforcing of car doors is a matter that has received considerable attention in the past. The Master Car Builders' Association has repeatedly urged the adoption of door stiffeners and adequate door fixtures. The present deplorable condition can only be laid to the indifference of the roads. Some roads, to be sure, have put the doors on their old box car equipment in good condition. If all had done what they could along this line there would be fewer cars running now with boards nailed to the bottom corners of the doors to hold them in the guides and cleats to keep them shut. Door hasps with short fasteners and poorly attached shoes and strips at the bottom of the doors are two features responsible for a great deal of trouble. Among the other things that should be corrected are tracks that allow the rollers to become misplaced or the door to be jarred out of the bottom guides. Horizontal stiffeners and burglar-proof bottom guides should be applied to cars not already so equipped. The loading of cars without adequate side door protection is responsible for considerable damage to doors.

This, of course, can only be overcome by a campaign of education among the shippers.

The question of providing side doors of substantial construction is important as a means of making box cars suitable for all kinds of lading and thus increasing the operating efficiency of the railroads. The amount of steel required for the work is almost negligible and every road should carry on the reinforcing of doors as rapidly as possible.

Save Paper Is the Order of the Day

The War Industries Board in an endeavor to conserve the paper supply of the country has ordered the various publishers to cut down the use of paper for their publications 10 per cent, beginning September 15. It has formulated some rather drastic measures, as will be noted in the announcement at the beginning of our general news section. None but bona-fide paid subscribers and advertisers are to be furnished, regularly, issues of these magazines. We will be forced, therefore, on account of this ruling, to cut off subscriptions that are not paid promptly in advance. Further than this it will be necessary to reduce somewhat the number of editorial pages in each issue. While in the past our regular issues have varied between 54 and 56 pages, it will now be necessary to have an average of 50. In order to do this without impairing the value of the paper to our readers, the editors will be called upon to edit more carefully every article that is published, printing only that part which is necessary to give the desired information. If, therefore, in the future our contributors feel that their articles have been severely "blue penciled," they will know the reason. We do not wish in the least to discourage our readers from making contributions. It is by their assistance that we have been able to make this paper a success and it is only by their continued assistance that we can hope to secure the best results.

The Traveling Engineers' Convention

The Railroad Administration decided wisely when it granted the Traveling Engineers' Association permission to hold its annual convention. It was a remarkable success from every standpoint. In attendance it was the largest convention ever held by the association—so great that the usual convention facilities of the hotel at which it was held were inadequate and it was necessary to hold the meetings in one of the neighboring theatres. Every session saw an overflow to the galleries, so interested were the men in the proceedings. Every part of the country was well represented by men on the firing line—whose duties brought them in daily contact with the physical operation of locomotives and trains. The interest in the proceedings and the patriotism displayed were remarkable and a most illuminating testimonial to the spirit of railway men in general towards the war.

Inspiring addresses were made by representative men and the thoroughness of the committee reports, together with the thoughtfulness with which they were discussed, plainly indicated that the members of the association appreciated the seriousness of the situation. Throughout the entire convention a spirit of patriotism, service and action was manifest. The subject of fuel economy—one of the most important questions before railroad men at this time—occupied a very large part of the convention's deliberations. Co-operation in its highest sense, to the end that the power may be well maintained, was a predominating feature. Paper restrictions placed upon us by the War Industries Board have made it impossible for us to elaborate as fully as we would like on the entire proceedings.

The railway supply companies exhibiting at the conven-

tion and particularly those having exhibits of an instructive nature are to be commended. It was important that they be there with their experts to render all the assistance possible in familiarizing the traveling engineers with the devices that are to be applied to the standard locomotives, as many of these devices will be new to some roads.

The business-like atmosphere of the entire convention, both among the railroad men and the supply men, was particularly noteworthy. Each came with a definite purpose—to learn and to instruct, which resulted in the best convention ever held by the Traveling Engineers' Association.

Last Call to Prepare for Winter

Our armies in France are constantly improving their positions, preparing themselves for their strategical winter quarters. Many of them will sacrifice their lives to strengthen the line that their positions may be properly defended when the snow and ice increase the hazards of war. Are we at home strengthening our lines, planting redoubts here and there to strengthen our positions in the face of the oncoming winter? The demands of transportation are constantly increasing. With every soldier that is carried abroad these demands are greater. Everything must be done to provide facilities for proper equipment maintenance through the winter, and every effort must be made while the weather is good to place the equipment in condition for the winter. Have you got those doors on your roundhouse? Is that additional cinder pit built? Has that turntable been repaired? Have you got that machine tool in your roundhouse shop, the lack of which caused you so much grief last winter? Have you built that open shed over your car repair tracks, and have you the many other things which are necessary for you properly to handle the equipment this winter? And to the shop men: Can't you put through a few more locomotives these next few months? Can't you speed up a little bit more and make a final drive to prepare for the winter season? It is the last opportunity for a spurt before the cold weather comes—let us all make the most of it.

Watch Fuel Consumption of Stoker Locomotives

One of the most valuable features of the stoker fired locomotive lies in the fact that it is not subject to the physical limitations of the fireman, but can be worked to full capacity for long periods. This very fact, however, makes it necessary to watch closely the condition of stoker fired engines to insure that high capacity is not secured by the extravagant use of coal. On hand fired locomotives the fireman has a strong incentive to watch the condition of the power, because if the locomotive is not operating economically he has to shovel more coal. If the stoker fired engine is working inefficiently, the fireman makes up for it by running the stoker faster. This applies whether the waste of fuel is due to the condition of the locomotive or to improper manipulation by the engineer.

The roundhouse forces usually depend on the enginemen to report valves out of square, blows in cylinder and valve rings, leaky steam pipes and other defects affecting the economy of the locomotive which cannot readily be located in a terminal inspection. Where the locomotives are fired by stokers it would probably be best to test for such defects at the roundhouse whenever the monthly inspection is made. Stokers can fire cheap grades of fuel satisfactorily and thus reduce the cost of coal burned in hauling trains. With a coal shortage threatened, and with war industries demanding more coal than can be supplied, we must eliminate the waste of even the poorest grades. To do this will require close checking by the road foremen of engines and careful inspection by the roundhouse forces.

Are You Prepared for Blizzards?

"One of the best roundhouse foremen I ever knew said he considered the only plan on which to run a roundhouse was like a fire station; always be ready for the unexpected and expect it to happen," said a railroad officer discussing the difficulties of the men operating engine terminals. In even the best regulated roundhouses emergencies are certain to arise and the way in which they are met is a fair measure of the efficiency of the roundhouse. To be ready for emergencies requires that all routine work be taken care of according to a well prepared plan. A roundhouse without a definite system of handling the common occurrences is not in condition to handle emergencies. There are any number of the roundhouses where the foreman must be consulted about every move that is made. If anything unusual happens it throws a heavy load on the foremen. To say that they usually handle such situations with a fair measure of success is a tribute to their resourcefulness, but not to their foresight. A man who is constantly working under pressure cannot be expected to respond to emergencies when they arise, as well as one who is fresh mentally and physically. We must first make arrangements to handle what can be anticipated; then we will be ready for the unexpected.

Winter is coming and with it will come cold weather. How severe it will be no one can foretell, but the roundhouses must be made ready for storms and extreme cold. During the blizzards of last winter the roundhouse men saw many ways in which the terminals could be put in better condition to handle power under such circumstances. Doubtless in many cases improvements were asked for which, for one reason or another, have not been installed. In that case, the thing to do now is to put up some makeshift wherever feasible and prepare to handle things in the best way possible under the existing conditions. One matter that should not be overlooked is making working conditions as pleasant as possible for the men. A roundhouse is a disagreeable place to work in at the best. If a man works in a freezing temperature, in wet and filthy pits, he is not apt to have much energy left when some emergency demands extra effort.

There is no more discouraging place than a roundhouse in winter when everything is going wrong. It is not to be wondered at that in some cases last winter the men, overwhelmed by the blizzards, gave up and went home. This winter the railroads have resting on them the responsibility of keeping munitions and supplies moving to our boys in France. We must keep the roads running. We must not have a single roundhouse shut down at any time. There are a few weeks left before cold weather will set in and every roundhouse man, during that time, should do all he can to get his terminal in condition to meet the unexpected.

NEW BOOKS

Government Iron and Steel Prices.—6 in. by 8 in., 78 pages, bound in paper. Published by the Penton Publishing Company, Cleveland, Ohio. Price \$1.

Owing to the number of extensions and revisions in the government prices for iron and steel since they were first fixed by the government with the aid of the American Iron & Steel Institute, the above manual was prepared to meet a need for complete price lists in convenient form. It covers the regulations to June 22, when President Wilson reaffirmed all iron and steel prices then in effect, with the exception of Lake Superior ore, for the third quarter, ending September 30, 1918. In addition to the tables of base prices which cover 62 pages, the book contains the official announcements, a directory of the committees and members, several curves showing the range of prices of various metals since the beginning of the war, and other information of interest.

ORGANIZE FOR THE LIBERTY LOAN

Elaborate Preparations Being Made to Make the Fourth Campaign a Gigantic Success on the Railways

THE railway men of the United States are out to make a new record for Liberty Bond subscriptions in the coming Fourth Liberty Loan Campaign. They subscribed for the first loan on a creditable scale, they doubled their first loan totals in the second campaign, and then they considerably more than doubled their second loan totals in the third campaign. If history repeats itself, as they say it does, the fourth loan totals are going to make the world sit up and take notice.

No stone is going to be left unturned to secure a big subscription. Under Director General McAdoo's leadership as expressed in Circular No. 50, the regional directors are instructing their federal and general managers to organize the railroads and as in the Third Loan campaign there will be a great number of committees reaching every man in railway service.

CIRCULAR NO. 56

It is the intention of the director general that a copy of Circular No. 56 should be given to every railway man. The circular in question has two pages, the first reading as reproduced in the center of this page and the other giving the details of the loan and the methods of subscribing on the partial payment plan. Employees will be allowed to pay for their bonds in eight monthly payments, but in cases where third loan payments are still being made the eight months period may be dated from the first of the year. The full details are given in the circular as follows:

The Fourth Liberty Loan campaign will begin on September 28 and close October 19, and in order to encourage employees to subscribe thereto federal managers are authorized to take such amount of the bonds as may be necessary to care for such subscriptions, and current federal funds may be used as

far as necessary in paying for such

Officers and employees will be permitted to pay in installments covering a period of not exceeding eight months, provision being made so that such installments may be paid by deduction on the pay roll.

In connection with the Third Liberty Loan it was permitted that payments on new subscriptions might begin at the expiration of the period covering installment payments on subscriptions to the Second Liberty Loan, in order to avoid making payment on both subscriptions at the same time.

For that reason payment to the Third Liberty Loan in many cases will not be completed until June, 1919. Since the last loan, however, employees generally have received substantial increases in wages, and therefore it is unnecessary to avoid the making of payments on two subscriptions at the same time.

Payments on subscriptions to the Fourth Liberty Loan may, however, when the subscriber is also making payments on subscriptions to the Third Liberty Loan, commence with the month of January, 1919, the period of eight months running therefrom. In cases where employees

are not making payments on subscriptions to Third Liberty Loan bonds, payments shall begin with the pay roll for the last half of October, 1918.

Employees will be credited with interest on bonds during the period of installment payments, and will be charged interest on deferred payment both at 4½ per cent. When the last installment payment is made the bond will be delivered to the subscriber. Adjustment of interest will be made in the last month's installment payment. Coupon (covering interest which matures during the period of installment payments) will be detached by the federal treasurer and the interest collected. Subscribers will, however, receive proper proportionate credit on account of such coupons in the adjustment of interest to be made in the last installment payment, as described above.

Should employees leave the service before completion of the payments, the amount paid will be refunded without interest.

Employees may pay for bonds in full at the time of subscription; or, if they subscribe on the installment plan, they may at any time pay up the unpaid installments in full and receive the bonds.

Employees should not hesitate to place their subscription with the federal treasurer of the road on which they are employed for fear that their local district may not receive credit for subscriptions, for arrangements are being made so that the subscriptions of railroad employees will be reported according to their homes, and the local district will in each case receive corresponding credit to apply toward its quota.

Instructions are being issued to regional directors relative to the formation of committees, etc., to organize and promote this work, with which committee when appointed all railroad employees are urged to cooperate.

While bonds are being issued in both coupon and registered form, I advise and urge that employees subscribe for registered bonds, which in case of loss or destruction by fire will be replaced by the United States Treasury.

In addition to sending out the circulars the director general has sent a letter to all regional directors instructing them further concerning the extensive and intensive campaign for Loan subscriptions.

Each regional director is doing his part to help the campaign along and long letters of instruction have been sent to every federal and general manager the country over. In addition to suggesting methods of appeal to the men, and directing the prompt printing of circulars,

subscription blanks, etc., these letters have advised the federal and general managers concerning the form of organization and procedure which should secure the best results. The eastern regional director in his letter emphasizes that, "No effort should be spared to make this campaign an overwhelming success."

Committees will be established at each shop composed of three or more of the officers in charge and employees. It may be necessary that further subcommittees be appointed to cover outlying shops.

All subscriptions received from railroad employees will be credited to the local committees according to the residences of the subscribers.

UNITED STATES RAILROAD ADMINISTRATION OFFICE OF THE DIRECTOR GENERAL OF RAILROADS

WASHINGTON, SEPTEMBER 18, 1918

CIRCULAR NO. 56

The patriotic support of railway employees to the Third Liberty Loan was more than gratifying. On some railroads practically every employee became a subscriber for one or more of these bonds.

Now that the Fourth Liberty Loan is about to begin, I earnestly urge all railroad officials and employees to cooperate in securing a "100 per cent" result on every railroad. I believe that where the officials and employees unite in a patriotic support the response will be even more gratifying than that to the Third Liberty Loan.

I realize that there are many instances where railroad employees are not financially able to assume additional obligations. In such instances there should be no criticism of the failure of an employee to subscribe to the Fourth Liberty Loan. I believe, however, that when the urgency of the need is presented to employees that few will fail in their financial support of the Government.

My attention has been called to the fact that in the past loans many employees have subscribed through their banks and through other agencies than the railroads. No criticism should be made against employees for subscribing to bonds in this way, but it is a matter of pride to the Railroad Administration that the employees on each railroad shall receive the credit for all subscriptions they make.

Government bonds are the safest investment in the world, and in making such an investment railroad employees at the same time have an opportunity to help win the war and give needed support to our noble sons and brothers who are risking and giving their lives upon the battle fields and upon the seas.

I hope that 100 per cent of the railroad employees will subscribe to the bonds of the Fourth Liberty Loan. I can think of nothing more inspiring than the great body of railroad employees effectively banded together to work for the success of the Fourth Liberty Loan, and I urge upon each railroad employee patriotically to do his share. In this way we can shorten the war, save many lives, and bring a glorious victory to America and to democratic principle everywhere.

McAdoo
Director General of Railroads.



FIRST STANDARD 0-8-0 SWITCHER

Built by the American Locomotive Company; Total Weight 214,000 Lb.; Tractive Effort 55,000 Lb.

THE first of the standard switching locomotives designed by the United States Railroad Administration has been recently completed at the Pittsburgh works of the American Locomotive Company. The locomotive is of the 0-8-0 type, of which 150 have been ordered for this year's production, to be distributed among 17 different railroads. These engines are designed on the basis of 55,000 lb. axle load and have a total weight of 214,000 lb. The driving wheels are 51 in. in diameter and the cylinders 25 in. in diameter by 28 in. stroke. With 175 lb. boiler pressure, the tractive effort is 55,000 lb.

The ratios indicate that for the service intended, the loco-

motives have ample boiler capacity. The boiler is of the straight top type with a telescopic barrel, the outside diameter of the first ring being 80 in. There are 230 two-inch tubes, laid out with $\frac{3}{4}$ -in. tube sheet spacing and 36 $5\frac{1}{2}$ -in. flues with $\frac{7}{8}$ -in. tube sheet bridges. The tubes and flues are 15 ft. long over the sheets. The firebox is designed with a horizontal mudring and does not include a combustion chamber. The dome is located on the second barrel course. It is 32 in. in diameter and the throttle valve is placed well forward to permit the boiler to be entered without the necessity for removing the throttle. The throttle rigging is of the Chambers inside connected type, the stem extending through a gland on the back head, located $8\frac{3}{4}$ in. to the right of the vertical center line. The boiler is fitted with a Security brick arch, Type A superheater and Franklin fire-door. The main frames are each cast in one piece and are 5 in. wide throughout, except for the slab section at the rear end. Here the width is reduced to $2\frac{1}{2}$ in., with a depth of $13\frac{1}{2}$ in., this section being increased for 30 in. at the extreme rear end where the deck plate is bolted to the frame, to 3 in. in width by 18 in. in depth. The upper rail is $6\frac{3}{4}$ in. deep over the pedestals and $5\frac{3}{8}$ in. deep at the smallest section between the pedestals. The lower rail is $4\frac{3}{8}$ in. in depth

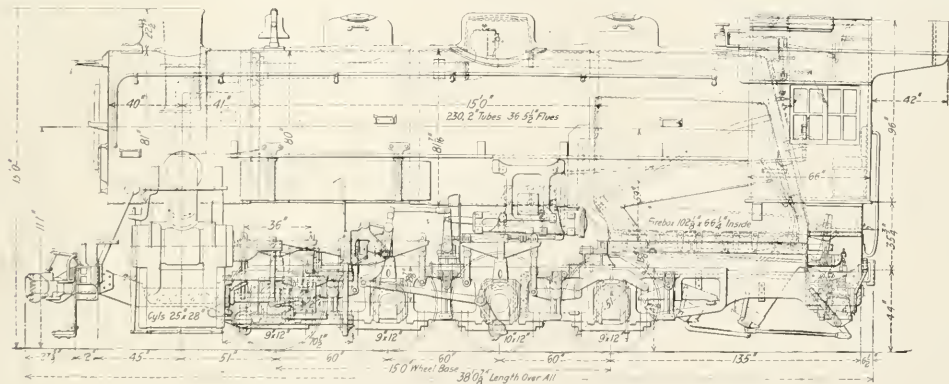

The United States Railroad Administration Standard 0-8-0 Type Locomotive

motives have ample boiler capacity. The boiler is of the straight top type with a telescopic barrel, the outside diameter of the first ring being 80 in. There are 230 two-inch tubes, laid out with $\frac{3}{4}$ -in. tube sheet spacing and 36 $5\frac{1}{2}$ -in. flues with $\frac{7}{8}$ -in. tube sheet bridges. The tubes and flues are 15 ft. long over the sheets. The firebox is designed with a horizontal mudring and does not include a combustion chamber.

The dome is located on the second barrel course. It is 32 in. in diameter and the throttle valve is placed well forward to permit the boiler to be entered without the necessity for removing the throttle. The throttle rigging is of

over the binders and $3\frac{7}{8}$ in. at the minimum section. Under the cylinders the section is increased to $9\frac{5}{8}$ in. deep. There is no front deck casting; the bumper casting is attached directly to the front end of the frame rails by means of 1-in. flanged angle plates.

The details of the running gear follow very closely in design those of the standard Mikado type locomotives, descriptions of which have already been published.* The piston is of the single plate, dished section type, the specifications calling for either cast or rolled steel. The bull ring is of

*See the *Railway Mechanical Engineer* for August, page 436, and September, page 491.

gun iron, riveted in place on the steel piston and fitted with two 3/4-in. by 7/8-in. gun iron packing rings. The face of the bull-ring is 4 3/4 in. wide, increased to a width of 7 in. at the bottom for 45 deg. on either side of the vertical center line. The cross-head is of the same design and interchangeable in detail with that used on the light Mikado type locomotive. Paxton-Mitchell metallic packing is used for both valve stems and piston rods.

Steam is distributed by a 14-in. piston valve, which is interchangeable with that used on both the light and heavy Mikado type locomotives, as are also the valve chamber

solidated safety valves, Ashton steam gates, Murden 2-in. flanged blow-off cocks, Sargent quick acting blower valve with Barco smoke box fittings, Hancock No. 11 non-lifting injectors, Nathan five-feed lubricators, Franklin flexible pipe couplings and the Radial buffer and Unit Safety draw-bar between the engine and tender.

The principal data and dimensions are as follows:

General Data.	
Gage	4 ft. 8 in.
Service	Switching
Fuel	Bit coal
Tractive effort	15,500 lb.

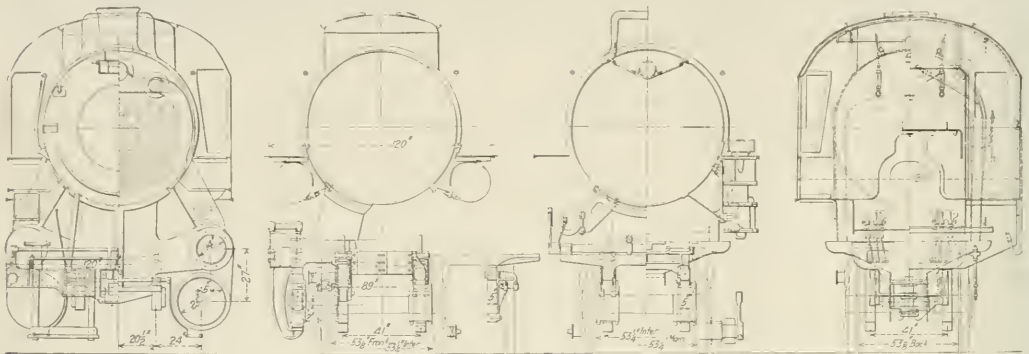

Cross Sections of the Standard Eight-Wheel Switcher

heads. The engines are fitted with the Baker valve motion and the Ragonnet power reverse gear.

Three standard tenders have been designed to meet the requirements of all the standard types of locomotives. These have 8,000 gal., 10,000 gal. and 12,000 gal. capacity respectively. The 8,000-gal. tender will be used with both the six and eight-wheel switching type locomotives. The tank is of the rectangular type ordinarily used with road engines and is carried on a Commonwealth cast steel frame. It is 27 ft.

Weight in working order	14,000 lb.
Weight on drivers	14,000 lb.
Weight of engine and tender in working order	381,900 lb.
Wheel base, driving	15 ft.
Wheel base, total	15 ft.
Wheel base, engine and tender	32 ft. 10 1/2 in.

Ratios	
Weight on drivers ÷ tractive effort	3.9
Total weight ÷ tractive effort	3.9
Tractive effort × diam. drivers ÷ equivalent heating surface	700.0
Equivalent heating surface ÷ grate area	80.5
Firebox heating surface ÷ equivalent heating surface	5.7
Weight on drivers ÷ equivalent heating surface	57.3
Total weight ÷ equivalent heating surface	57.3

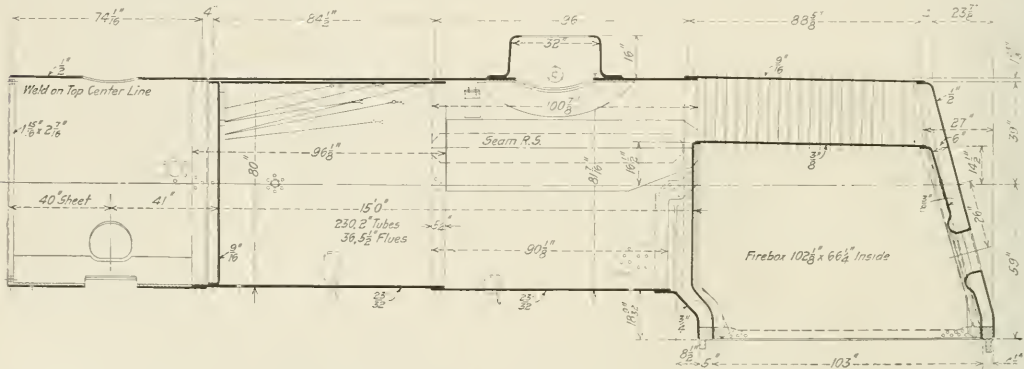

Boiler for Standard Eight-Wheel Switching Locomotive

long by 10 ft. wide by 5 ft. 1 in. high and has a coal capacity of 16 tons. The tank is fitted with the Locomotive Stoker Company's coal pusher. The four-wheel trucks are built up with cast steel side frames and bolsters, and are fitted with 33-in. cast steel wheels mounted on axles having 6-in. by 11-in. journals. The trucks have a wheel base of 5 ft. 10 in. and are spaced 15 ft. 10 in. between centers.

Among the more important specialties are three 3-in. Con-

Volume both cylinders	15.9 cu. ft.
Equivalent heating surface ÷ vol. cylinders	244.5
Grate area ÷ vol. cylinders	29.9

Cylinders	
Diameter and stroke	25 in. by 28 in.

Valves	
Kind	Piston
Diameter	14 in.
Great travel	6.34 in.
Steam lap	.1 in.
Exhaust clearance	.0 in.
Lead in full gear	1/4 in.

<i>Wheels</i>	
Driving, diameter over tires.....	51 in.
Driving journals, main, diameter and length.....	10 in. by 12 in.
Driving journals, others, diameter and length.....	9 in. by 12 in.

<i>Boiler</i>		<i>Straight top</i>
Style.....		
Working pressure.....	175 lb. per sq. in.	
Outside diameter of first ring.....	80 in.	
Firebox length and width.....	102½ in. by 66½ in.	
Firebox plates, thickness.....	Crown, sides and back, ¾ in.; tube, 1½ in.	
Firebox, water space.....	Front, 5 in.; sides and back 4½ in.	
Tubes, number and outside diameter.....	230—2 in.	
Flues, number and outside diameter.....	36—5½ in.	
Tubes and flues, length.....	15 ft.	
Heating surface, tubes and flues.....	2,569 sq. ft.	
Heating surface, firebox including arch tubes.....	212 sq. ft.	
Heating surface, total.....	2,781 sq. ft.	

FURTHER INCREASE IN WAGES TO MECHANICAL DEPARTMENT MEN

Director General McAdoo on September 5 issued Supplement 7 to General Order 27, granting further increases in wages to all clerks, station employees, stationary engineers, boiler-washers, power transfer and turntable operators, and common laborers in shops, roundhouses, stations, storehouses and warehouses. It contains general rules for promotion and adjustments of grievances.

The new rates are effective as of September 1, 1918. Back pay from January 1, 1918, not already paid out, will, of course, be based on the rate established in General Order 27. Under these supplements, the eight-hour day is established throughout for these employees, with overtime up to 10 hours on a pro rata basis with time and one-half thereafter.

SUPPLEMENT 7 TO GENERAL ORDER 27

Effective September 1, 1918, superseding General Order 27, and in lieu thereof, as to the employees herein named, the following rates of pay and rules for overtime and working conditions for all clerical forces in all departments, and for certain employees in stations, storage or terminal warehouses, docks, storehouses, shops and yards, upon railroads under federal control, are hereby ordered:

ARTICLE I.—RATES OF PAY

(a) For all employees who devote a majority of their time to clerical work of any description, including train announcers, gatemen, checkers, baggage and parcel room employees, train and engine crew callers and the operators of all office or station equipment devices, (excepting such as come within the scope of existing agreements or those hereafter negotiated with the railroad telegraphers), establish a basic minimum rate of \$62.50 per month; and to this basic minimum rate and all rates of \$62.50 and above, in effect as of January 1, 1918, prior to the application of General Order 27, add \$25 per month, establishing a minimum rate of \$87.50 per month.

(b) This order shall apply to chief clerks, foremen, subforemen and other similar supervisory forces of employees herein provided for.

(c) For office boys, messengers, chore boys and other employees under 18 years of age filling similar positions, and station attendants, establish a basic minimum rate of \$20 per month, and to this basic minimum rate and all rates of \$20 per month and above, in effect as of January 1, 1918, prior to the application of General Order 27, add \$25 per month, establishing a minimum rate of \$45 per month.

(d) For all other employees not otherwise classified, such as janitors, elevator and telephone switchboard operators, office, station and warehouse watchmen, establish a basic rate of \$45 per month, and to this basic minimum rate and all rates of \$45 per month and above, in effect as of January 1, 1918, prior to the application of General Order 27, add \$25 per month, establishing a minimum rate of \$70 per month.

(e) The same increases provided for in Sections (a), (b), (c) and (d) of this article, shall apply to employees named therein paid on any other basis.

(f) The wages for new positions shall be in conformity with the wage for positions of similar kind or class where created.

ARTICLE II.—STATIONARY ENGINEERS (STEAM), FIREMEN AND POWER HOUSE OILERS

(a) For all stationary engineers (steam), establish a basic minimum rate of \$85 per month, and to this basic minimum rate, and all rates of \$85 and above, in effect as of January 1, 1918, prior to the application of General Order 27, add \$25 per month, establishing a minimum rate of \$110 per month.

(b) This order shall apply to chief stationary engineers.

(c) For all stationary firemen and power house oilers, establish a basic minimum rate of \$65 per month, and to this basic minimum rate, and all rates of \$65 and above, in effect as of January 1, 1918, prior to the application of General Order 27, add \$25 per month, establishing a minimum rate of \$90 per month.

ARTICLE III.—LOCOMOTIVE BOILER WASHERS.

For all locomotive boiler washers who were on January 1, 1918, prior to the application of General Order 27, receiving less than 26 cents per hour, establish a basic minimum rate of 26 cents per hour, and to this basic minimum rate, and all hourly rates of 26 cents and above, add 12 cents per hour, establishing a minimum rate of 38 cents per hour, provided that the maximum shall not exceed 50 cents per hour.

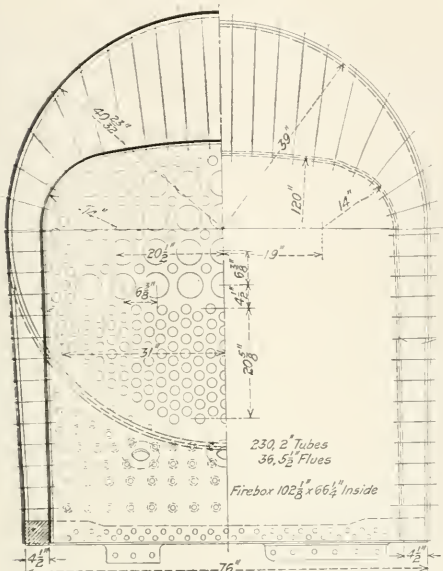

Half Sections Through the Firebox Showing the Tube Sheet Layout

Superheater heating surface.....	673 sq. ft.
Equivalent heating surface.....	3,737 sq. ft.
Grate area.....	46.6 sq. ft.

Tender

Tank.....	Water bottom
Frame.....	Cast steel
Weight loaded.....	167,900 lb.
Wheels, diameter.....	33 in.
Journals, diameter and length.....	6 in. by 11 in.
Water capacity.....	8,000 gal.
Coal capacity.....	16 tons

* Equivalent heating surface = total evaporating heating surface + 1.5 times the superheating surface.

LIBERTY MOTOR CYLINDERS.—While formerly all automobile engines and American aviation engines had cast iron cylinders, the J. G. Brill Company of Philadelphia, railway car builders, are making steel cylinders for some of the Liberty motors by a process exactly similar to that used for making shells. A steel billet, almost white-hot, is placed in a mold of the proper size for the outside of the cylinder; then a plunger operated by hydraulic pressure is forced into the steel. The result is a steel cup with thin walls, all ready to be machined into a fini-hed cylinder. After this the sheet steel outer casing that forms the space for the water-jacket is attached by the electric welding process. Steel cylinders for Liberty motors are also being made by the Ford Motor Company, which devised a method of producing steel cylinders out of tubing.—*The World's Work.*

ARTICLE IV.—POWER TRANSFER AND TURNSTABLE OPERATORS

For all operators of power driven transfer and turntables who were on January 1, 1918, prior to the application of General Order 27, receiving less than 21 cents per hour, establish a basic minimum rate of 21 cents per hour, and to this basic minimum rate, and all hourly rates of 2) cents and above, add 12 cents per hour, establishing a minimum rate of 33 cents per hour, provided that the maximum shall not exceed 45 cents per hour.

ARTICLE V.—SHOP, ROUNDHOUSE, STATION, STOREHOUSE AND WAREHOUSE EMPLOYEES (EXCEPT EMPLOYEES PROVIDED FOR IN HARBOR AWARDS).

(a) For all laborers employed in and around shops, roundhouses, stations, storehouses and warehouses (except employees provided for in harbor awards), such as engine watchmen and wipers, fire builders, ashpitmen, boiler washer helpers, flueborers, truckers, stowers, shippers, coal-passers, coal chute men, etc., who were on January 1, 1918, prior to the application of General Order 27, receiving less than 19 cents per hour, establish a basic minimum rate of 19 cents per hour, and to this basic minimum rate, and all hourly rates of 19 cents and above, add 12 cents per hour, establishing a minimum rate of 31 cents per hour, provided that the maximum shall not exceed 43 cents per hour.

(b) For all common labor in the departments herein referred to and not otherwise provided for, who were on January 1, 1918, prior to the application of General Order 27, receiving less than 16 cents per hour, establish a basic minimum rate of 16 cents per hour, and to this basic minimum rate and all hourly rates of 16 cents and above, add 12 cents per hour, establishing a minimum rate of 28 cents per hour, provided that the maximum shall not exceed 40 cents per hour.

ARTICLE VI.—MONTHLY, WEEKLY OR DAILY RATES.

For all monthly, weekly or daily rated employees, in the departments herein referred to, and not otherwise provided for, increase the rates in effect as of January 1, 1918, prior to the application of General Order 27, on the basis of \$25 per month.

ARTICLE VII.—MAXIMUM MONTHLY WAGE.

No part of the increases provided for in this order shall apply to establish a salary in excess of \$250 per month.

ARTICLE VIII.—PRESERVATION OF RATES.

(a) The minimum rates, and all rates in excess thereof, as herein established, and higher rates which have been authorized since January 1, 1918, except by General Order 27, shall be preserved.

(b) Employees temporarily or permanently assigned to higher rated positions, shall receive the higher rates while occupying such positions; employees temporarily assigned to lower rated positions shall not have their rates reduced.

ARTICLE IX.—EXCEPTION

The provisions of this order will not apply in cases where amounts less than \$30 per month are paid to individuals for special service which only takes a portion of their time from outside employment or business.

ARTICLE X.—HOURS OF SERVICE

Eight consecutive hours, exclusive of the meal period, shall constitute a day's work.

ARTICLE XI.—OVERTIME AND CALLS

(a) Where there is no existing agreement or practice more favorable to the employees, overtime shall be computed for the ninth and tenth hour of continuous service, pro rata on the actual minute basis, and thereafter at the rate of time and one-half time. Even hours will be paid for at the end of each pay period; fractions thereof will be carried forward.

(b) When notified or called to work outside of established hours employees will be paid a minimum allowance of three hours.

(c) Employees will not be required to suspend work during regular hours to absorb overtime.

ARTICLE XII.—PROMOTION AND SENIORITY

(a) Promotions shall be based on ability, merit and seniority; ability and merit being sufficient, seniority shall prevail, except, however, that this provision shall not apply to the personal office forces of such officers as superintendent, trainmaster, division engineer, master mechanic, general freight or passenger agent, or their superiors in rank and executive officers. The management shall be the judge, subject to an appeal, as provided in Article XIII.

(b) Seniority will be restricted to each classified department of the general and other offices and of each superintendent's or master mechanic's division.

(c) Seniority rights of employees referred to herein, to: (1)

New positions, (2) vacancies: will be governed by paragraphs (a) and (b) of this article.

(d) Employees declining promotion shall not lose their seniority.

(e) Employees accepting promotion will be allowed 30 days in which to qualify, and failing, will be returned to former position without loss of seniority.

(f) New positions or vacancies will be promptly bulletined for a period of five days in the departments where they occur. Employees desiring such positions will file their applications with the designated official within that time, and an appointment will be made within 10 days thereafter. Such position or vacancy may be filled temporarily pending an assignment. The name of the appointee will immediately thereafter be posted where the position or vacancy was bulletined.

(g) In reducing forces, seniority shall govern. When forces are increased employees will be returned to the service and positions formerly occupied, in the order of their seniority. Employees desiring to avail themselves of this rule must file their names and addresses with the proper official. Employees failing to report for duty or give satisfactory reason for not doing so within seven days from date of notification will be considered out of the service.

(h) A seniority roster of all employees in each classified department who have been in the service six months or more, showing name, date of entering the service and the date of each promotion or change, will be posted in a place accessible to those affected.

(i) The roster will be revised and posted in January of each year, and shall be open to correction for a period of 60 days from date of posting, on presentation of proof of error by an employee or his representative. The duly accredited representative of the employee shall be furnished with a copy of roster upon written request.

ARTICLE XIII.—DISCIPLINE AND GRIEVANCES

(a) An employee disciplined, or who considers himself unjustly treated, shall have a fair and impartial hearing, provided written request is presented to his immediate superior within five days of the date of the advice of discipline, and the hearing shall be granted within five days thereafter.

(b) A decision will be rendered within seven days after the completion of hearing. If an appeal is taken it must be filed with the next higher official and a copy furnished the official whose decision is appealed within five days after date of decision. The hearing and decision on the appeal shall be governed by the time limits of the preceding section.

(c) At the hearing or on the appeal the employee may be assisted by a committee of employees or by one or more duly accredited representatives.

(d) The right of appeal by employees or representatives, in regular order of succession and in the manner prescribed up to and inclusive of the highest official designated by the railroad, to whom appeals may be made, is hereby established.

(e) An employee on request will be given a letter stating the cause of discipline. A transcript of evidence taken at the investigation or on the appeal will be furnished on request to the employee or representative.

(f) If the final decision decrees that charges against the employee were not sustained, the record shall be cleared of the charge; if suspended or dismissed, the employee shall be returned to former position and paid for all time lost.

(g) Committees of employees shall be granted leave of absence and free transportation for the adjustment of differences between the railroad and the employees.

ARTICLE XIV.—RULES FOR APPLICATION OF THIS ORDER

(a) It is not the intention of this order to change the number of days per month for monthly paid employees. The increases per month provided for herein shall apply to the same number of days per month which were worked as of January 1, 1918.

(b) The pay of female employees for the same class of work shall be the same as that of men, and their working conditions must be healthful and fitted to their needs. The laws enacted for the government of their employment must be observed.

ARTICLE XV.—INTERPRETATION OF THIS ORDER

The rates of pay and rules herein established shall be incorporated into existing agreements, and into agreements which may be reached in the future on the several railroads, and should differences arise between the management and the employees of any of the railroads as to such incorporation, intent or application of this order prior to the creation of additional railway boards of adjustment, such questions of difference shall be referred to the director of the Division of Labor for decision, when properly presented, subject always to review by the director general.

Agreements or practices, except as changed by this order, remain in effect.

TRAVELING ENGINEERS' CONVENTION

A Meeting Full of Patriotism and Zest. Fuel Conservation and Other Important Problems Discussed

THE twenty-sixth convention of the Traveling Engineers was held at the Olympic Theatre, Chicago, September 10, B. J. Feeny, fuel supervisor, southern region, U. S. R. A., presiding. The meeting was opened with an invocation by Bishop Fallows.

ADDRESS BY PRESIDENT FEENY

The government of the United States has taken control of the railroads and has placed the Hon. W. G. McAdoo in charge of them as director general of the United States Railroad Administration. This association stands absolutely loyal to him first, last and at all times.

We are all in the service of the government and we must render our service to the greatest extent. Each and every one of us must do all in our power to obtain the maximum efficiency from men, material and supplies. It becomes the sacred duty of every true and loyal American to concentrate his thoughts, his energy and his very life, if necessary, to the supreme task of winning this war. If we fail to win this war the liberty so dear to the hearts of the American people will be a thing of the past.

This association is one of the vitally important factors in winning the war, for without good transportation our men, money and munitions would be useless. Man power and motive power will win the war. They are today the two greatest necessities, and any preventable waste in this world's crisis is inexcusable and indefensible. Upon members of this association rests a great responsibility in conserving men and material, and for the part you are playing in this war you are not alone answering to yourself and your government, but you are answering to the boys over there who are winning the war. Conservation is of prime importance—conservation of every kind. Conservation of fuel is of vital importance. With the expansion of our war industries, the increased demand for fuel for our navy, shipping board and railroads, the most drastic fuel economy must be enforced if this country is to escape a most serious fuel shortage next winter.

Greater efficiency must be obtained than ever before and this must be done by education and co-operation. It is possible to get better results from nearly all railroads with practically no additional expense, if every one will profit by his experience and put the knowledge so gained into effect. We should analyze what can be done under present conditions on the railroads which we serve and then make such recommendations as will be justified under win-the-war conditions.

Our government wants conservation—willing conservation

if possible. It will enforce conservation if necessary, and from now on let every man of this association who loves America and liberty say "I will conserve. I will put my best efforts forth every day in order that my country will win this war."

In reviewing the requirements and duties of traveling engineers on the various roads, I find that there is a lack of uniformity as to just what is required of them. Standardization of the duties of traveling engineers is necessary to render efficient service. Familiarity of its detail is essential on account of the large number of inexperienced men that

are being placed on the locomotives due to the great number of experienced men who have responded to the call of our country to take up arms, and I earnestly recommend to you—

First—To apply yourselves entirely to the management and operation of locomotives.

Second—To co-operate with the various operating departments.

Third—By making suggestions for the improving of conditions which come to your attention in the performance of your locomotive duties.

The Railway Supplymen's Association has arranged for our benefit a splendid exhibit of interesting locomotive supplies and their representatives are here to explain the merits of their material and devices. Much credit is due to the supplymen for their educational work, for we have learned from them the most successful way to apply and operate the material and devices which increase the efficiency of the locomotive.

All members should spend as much time around, and give as much attention as possible to, the exhibits. It is far more necessary than ever before on account of the distribution of government standard locomotives.

On the twenty-eighth day of this month every man in the United States will be facing a financial obligation. A little forethought now, a little economy, a little inconvenience, will enable you to meet this obligation and it will give you a warm feeling in your heart when you have fulfilled it. The obligation I refer to is the Fourth Liberty Loan.

In entering this war we have taken upon ourselves a great responsibility, and one which will command the labor and service of every citizen. We must contribute the men and material necessary to reach a turning point and to keep that point behind us forever. We are in the war and we must win the war!

I recommend that our secretary be authorized to send a telegram to the President of the United States, Hon. Woodrow Wilson, and to the Hon. W. G. McAdoo, director general,



B. J. Feeny
President, Traveling Engineers' Association

United States Railroad Administration, informing them we are in convention to help win the war and reaffirm our pledge of full support.

ADDRESS BY FRANK McMANAMY

There has never been a time in the history of American railroads when the motto of the Traveling Engineers' Association, which is: "To improve the locomotive service on American Railroads," meant as much as it does today. And there is no man in railroad service who can do more to improve the locomotive service on American railroads than the traveling engineer, if he is given proper support. The convention of the Traveling Engineers' Association was therefore authorized by the Railroad Administration because of the value men who are on the firing line of railroad operation obtain from a convention of this kind, where they can interchange ideas and discuss problems and difficulties which all of us must meet and overcome if the national railroad system is to be successfully operated.

Under government operation the work and the difficulties of the traveling engineer have been greatly increased. He is apt to be called upon to look after every known type of locomotive and is expected to obtain equally good results out of all of them.

When I issued instructions to increase shop hours to 70 per week, which, roughly speaking, meant an increase of 20 per cent in shop efficiency and shop output, the response of the railroad employees was extremely gratifying and we have yet to find the first instance where after knowing that it was the desire of the government that the shop hours be increased, that the men refused or failed to work the desired number of hours. The same is true of the men in road service, and men in hundreds of instances gave up their rest period to prevent locomotives, which could not be properly housed, from freezing up and thereby being disabled. The increase in hours in railroad shops has enabled us to increase the number of locomotives repaired about 500 each week over the corresponding week last year and to decrease the percentage of locomotives which are out of service for repairs requiring more than 24 hours from over 18 per cent to a fraction above 14 per cent.

Everyone knows the difficulty of building up the condition of motive power during a period of heavy business, and particularly when there is a shortage of skilled labor at the same time; but this has been accomplished by the government during the most trying period in the history of the American railroads.

When the director general assumed control of the railways it became possible for the first time in the history of the country to adopt and enforce standards. The necessity, during the past winter of transferring locomotives from one line to another and the difficulty experienced in making repairs to such locomotives, when away from their home lines, emphasized the importance of standardizing locomotive construction and this was at once started through the medium of a committee composed of well known mechanical department officials from different sections of the country. As a result of the work of this committee 12 standard specifications for locomotives were agreed upon and 1514 United States standard locomotives have already been ordered and the locomotives are now being constructed at the rate of about 50 per week.

That the standardization of locomotives will facilitate not only the repairs to locomotives and the building of new ones has already been demonstrated, because when standard drawings and patterns have been made it eliminates further delay either in the drafting room or in the pattern shop and enables larger quantities of material to be ordered. Mechanics also work to better advantage on locomotives of the same general type and dimensions.

President Wilson, on April 15, 1917, said:

"To the men who run the railways of the country, whether they be managers of operative employees, let me say that the railways are the arteries of the nation's life, and that upon them rests the immense responsibility of seeing to it that these arteries suffer no obstruction of any kind, no inefficiency or slackened power."

The traveling engineer comes more closely in contact with the men who operate the locomotives of the country than any other railroad official and can do more to prevent the "inefficiency and slackened power," referred to by President Wilson than any other railroad official.

While the duties of the traveling engineer can be subdivided into a multitude of different items they can be broadly covered under two heads. First, to see that the motive power is kept in good condition for service. Second, to see that it is efficiently and economically operated. Do not understand from this that the traveling engineer is supposed to look after the operation of shops and roundhouses because that is a different line of work, but he should see that all defects which develop in service which prevent economical and efficient performance, should be properly reported and he should insist that repairs be made before the locomotive is returned to service; to carry this out successfully his orders to hold a locomotive for repairs should be observed the same as the orders of federal inspectors. Locomotives should not be offered for service unless they are in a condition to make a successful trip and the traveling engineer should, as far as possible, see that they are not permitted to go into service unless in good condition. The traveling engineer should know the condition of every locomotive under his charge and should see to it that they are shopped for repairs before their condition becomes such that they might reasonably be expected to cause failure on the road. Instructing enginemen as to the proper and efficient performance of their work is not the least of his duties, and the man who is most successful in having the locomotives properly maintained will obtain the greatest degree of co-operation from the enginemen under him and without this his road will be exceedingly rough.

The economic use of fuel is one of the things that is usually under the direction of the traveling engineer and to bring this about he must have the co-operation of the shopmen, the engineers and the firemen. Instructing enginemen as to the proper use of the air brake, operation of the locomotive, transportation rules and proper methods of firing are some of the things which he must look after in addition to the general condition of the locomotives while he is on the road. This no doubt sounds like a pretty big contract, and so it is, but it is only an outline of what is being successfully done by the various traveling engineers.

It is particularly important at this time that every railroad man should do all in his power to promote efficiency in locomotive operation. Winter is but a few months away and we should bear in mind the experiences of last winter and make every effort to go into the coming winter with everything in the best shape it is possible to get it.

It requires about four tons of shipping to maintain one American soldier in France. We have already more than a million and a half of our boys "over there" and it is proposed to put as many more millions there as may be necessary to carry the war to a successful conclusion. It is up to the railroads not only to supply cargoes for this four tons of shipping for each soldier, but to transport the material for building the ships. During the coming winter every railroad man must prepare to do a little more and do it a little better than he has ever done before.

Order No. 8, issued by the director general of railroads, February 21, 1918, reads in part:

"The government now being in control of the railroads, the officers and employees of the various companies no longer serve a private interest. All now serve the government and the public interest only. I want the officers and employees to get the spirit of the new era."

No more important principle has been advanced in connection with the government operation of railroads.

The government did not wish to assume, in addition to the other burdens imposed upon it, the task of reorganizing and operating the American railroads. There was no particular desire on the part of the government or any substantial portion of the American people to go into the railroad business at that time. The railroads were placed under federal control because in the crisis brought about by the war they had practically ceased to function under private management.

I shall not attempt to explain the reasons for this condition because they are many, and the important ones are well known. It is sufficient to state that in a national crisis, when unusual and excessive burdens were placed upon the railroads, when it became essential that the railroads should operate at their highest efficiency as a national unit, the many weak points in the plan of operating the railroads under private management, in numerous systems or units had caused such congestions in various centers of industry that the collapse of the entire transportation system became imminent, at a time when such a collapse would be a world wide calamity. No organization with less authority and power than the federal government could control and direct such a huge task as the nationalization of the American railroads.

During the period immediately preceding the taking over of the railroads by the government we have all heard many railroad men express in a somewhat sarcastic spirit the wish that the government would attempt to operate the railroads, just to see what kind of a mess they would make of it. Such expressions were doubtless made without having given careful consideration to the fact that Uncle Sam has a score of 100 on everything that he has ever undertaken. The United States makes no failures. The question is no longer, can the government successfully operate the railroads, because that has already been demonstrated, the only question now is, how big a success is it going to be? That question will be largely determined by the spirit in which the principles laid down by the President and the director general are carried out and no body of men can do more to aid in carrying out those principles than the members of the Traveling Engineers' Association.

Again quoting from Order No. 5 issued by the director general of railroads:

"Supreme devotion to country, an invincible determination to perform the imperative duties of the hour while the life of the nation is imperiled; by war, must obliterate old enmities and make friends and comrades of us all. There must be co-operation, not antagonism; confidence, not suspicion; mutual helpfulness, not grudging performance; just consideration, not arbitrary disregard of each other's rights and feelings; a fine discipline based on mutual respect and sympathy; and an earnest desire to serve the great public faithfully and efficiently. This is the spirit and purpose that must pervade every part and branch of the national railroad service."

The importance and the greatness of the service which the American railroad men are called upon to render is, I fear, not fully realized. Everyone knows that we are in this war to win and that we are going to win and the splendid reports of the work of our boys in France leaves no doubt in any one's mind as to what they are doing and what they are going to do; but the thing that railroad men here must realize is that they are an essential part of the American Expeditionary Force. That they are truly a part of the American army. That they have an important link in the chain of communications with the front to maintain and to operate successfully and that a failure of any part of our transportation system is the only thing that can possibly endanger the success of the Allied army. But such a failure will not occur if we who are operating the railroads do our bit as well as the boys who have gone across. Just as sure as Washington crossed the Delaware Pershing with a million of our boys behind him will cross the Rhine.

Mr. McManamy took exception orally to the operating features of the government standard locomotives, which he characterized as among the best ever designed. He said there was nothing fresh about them and for that reason

it should be easy for the enginemen to handle and adjust them. He anticipated that they would eliminate the troubles encountered in maintaining equipment borrowed from other lines. This foreign power, Mr. McManamy stated, was often held up for periods as long as 30 days, due to delays in securing material with which to make repairs.

THE RAILWAYS IN THE WAR

BY SAMUEL O. DUNN
Editor of the Railway Age

On the first occasion when I addressed you (in 1911) the two subjects pertaining to the railway business which were uppermost in the public mind were those of advances in rates and of operating efficiency. The Interstate Commerce Commission had just recently decided the first important case which the railway companies instituted to secure general advances in rates. You will recall that the commission refused to permit the advances upon the ground that they were unnecessary.

The decision rendered at that time affords a striking contrast to certain steps which recently have been taken, and which have resulted in passenger rates being advanced about 50 per cent and freight rates about 25 per cent. One cannot help wondering what would have been the course of developments in the field of transportation if the Interstate Commerce Commission had seen the light at that time, and granted the advances in rates which subsequent developments have conclusively demonstrated were needed.

Recalling that decision of the Interstate Commerce Commission caused me to recall also the most sensational development which occurred in the hearings in that case. This was the attempt of Mr. Louis D. Brandeis, an attorney for the shippers, to show that the railway managements, by the application of the principles of so-called "scientific management," could reduce their operating expenses one million dollars a day. The railways are now being operated as a single system by the government. Expenses are increasing more rapidly than ever before. This, therefore, would be a most opportune time for those in charge of their management to put the principles of Mr. Brandeis to the crucial test. But they are not doing so—one circumstance among many which indicate that the attacks which were made upon the railway companies for alleged operating inefficiency were as unjust as many attacks which have been made, and are still being made on them upon other grounds.

While, however, the railways did not display much alacrity in applying the principles of Mr. Brandeis, they did show great alacrity and energy in adopting every feasible means for increasing the efficiency of operation. The statistics of the Interstate Commerce Commission reflect in a striking manner the results obtained. In 1911 the number of tons carried one mile per freight locomotive was 6,913,259. In 1915 the figure had been increased to almost 10,000,000, or almost 50 per cent. In 1917, the last year of private operation, the average number of tons of freight carried one mile by each locomotive was 12,636,545, an increase over 1911 of 85 per cent. This enormous increase in the amount of freight traffic handled by each locomotive was due both to increases in the average tons hauled per train, and in the average miles made per locomotive. The average tons per train increased from 383 in 1911 to 649 in 1917, or 59 per cent. The average miles traveled per locomotive per day increased from 55½ in 1911 to 67 miles in 1917, or 20 per cent.

It is impossible accurately to estimate the amount of saving in operating expenses which was caused by this great increase in locomotive efficiency, but it amounted to literally hundreds of millions of dollars annually. There is now a tendency manifested in some quarters to attempt to make it appear that the inefficiency with which the railways were being operated made it necessary for the government to

take them over. I do not criticize the government for taking charge of railroad operation. As an American citizen, I should feel deeply gratified if under government control the operation of the railways should be made far more efficient than it was under private management. The highest efficiency in railroad operation is essential as one important means to winning this terrible war for democracy and humanity. At the same time I challenge as without foundation the allegation that the inefficiency of private management made necessary the adoption of government control. The facts demonstrate beyond question that in the last year of private operation the power of the railways as a whole was more efficient and was operated more efficiently than ever before. The same thing may be shown as to every branch of operation.

How was this great increase in locomotive efficiency attained? It was attributable partly to the work of the managers and officers of the railways, including the members of this association, who have direct charge of the operation of the locomotives. It was partly due to the work of the builders of the locomotives and of the numerous concerns which are engaged in the manufacture of the specialties used on equipment. The best type of locomotive will not produce good results unless it is skillfully operated. On the other hand, the most skillful railway motive power officer cannot get the best results except with locomotives that are well designed, well built, and equipped with the most modern devices. The increase in locomotive efficiency has been due to the fact that, on the one side, there has been constant progress in the design of locomotives and in the invention and introduction of new devices to make them better machines, and that, on the other hand, there has been constant improvement in their operation. The work of those who have operated the locomotives and of those who have engaged in inventing and perfecting new devices for improving them have constantly reacted, one upon the other, and the result has been the wonderful progress to which I have referred.

This co-operation between the railways, on the one side, and the locomotive builders and specialty manufacturers on the other, will be as essential to continued progress in the future as it has been in the past.

We have heard a great deal within recent months about standardization of locomotives. I do not intend to discuss that matter here. There is, however, one thought regarding it which I desire to leave with you. This is that progress in design is far more important than standardization of design. I question very much whether, if an extensive program of locomotive standardization had been adopted by the railways of this country ten years ago it would now be possible to show, as I have shown, that there was such a great improvement between 1911 and 1917 in the design, equipment and operation of locomotives that the amount of freight handled with each locomotive was increased on the average 85 per cent.

Of all the changes which have occurred in the railroad business since it was my privilege to address your association before, the greatest, of course, are those which have been caused by the war in Europe and by the final entrance of our country into it. It is questionable if there is any class of American citizens engaged in industrial pursuits who have felt the effects of this war more than the railway officers.

It caused an enormous increase in railroad business in this country in 1916, the last year before we entered it. It caused a still greater increase in railway business in 1917, the first year that our country was in it. The organizations and facilities of the railways, after a long period of restrictive regulation were inadequate to cope with this enormously augmented business. There is no part of the record which has been made by our country since we entered the war which affords more just ground for pride and gratification than the way in which the officers of the rail-

ways have risen to the demands of the occasion. During the first nine months that the United States was in the war the roads, in co-operation with the War Department, raised regiment after regiment of engineers to be sent to France, and they gave 70,000 of their officers and employes to the army, many of these going "over there" as members of these engineer regiments. Under the direction of the Railroads' War Board they handled a traffic which two years before it would have been inconceivable that they could have handled with the facilities at their disposal. Finally, there came the terrible winter of 1917-18. The weather experienced was the most severe ever known. One of the great trunk lines in the most congested eastern territory spent as much for removing ice and snow in that winter as it did in all the previous six winters combined. That simple fact strikingly illustrates the conditions with which the operating departments of the railways had to deal. Operating expenses were increasing so fast that they were rapidly wiping out earnings. The companies were confronted with demands from their employes for enormous increases in wages—demands many of which it was clear ought to be granted both as a matter of expediency and as a matter of justice. You know the sequel. The government decided that it must step in and take control of railroad operation.

This development was regarded with alarm and regret by a very large majority of railway officers. They did not know how revolutionary the change would prove to be. They could not anticipate how it would affect them individually. What has been the attitude of railway officers toward government control? It has been that of American citizens. They have put the welfare of their country above every other consideration. They said, in effect, at the start that whether it was right or wrong, wise or unwise, for the government to take over the railways, now that it had done so they would loyally give it the best service of which they were capable in any place to which it might assign them. That has been their attitude ever since. It will be their attitude until the war is won.

RAILWAY FUEL CONSERVATION

BY EUGENE McAULIFFE

Manager Fuel Conservation Section, Division of Operation,
United States Railroad Administration

There is no governmental function of greater importance in existence today than that of the United States Railroad. Men have said that food would win the war; that fuel, that men and munitions, that ships would win the war. They will, after the United States Railroad has gathered the grain, the coal, the iron, the lumber, and all the other raw materials, and transported them to the mill, furnace, and factory, to again move the finished product to ship-side. I am wondering whether or not we have measured up the job that remains for "the second line" to complete! Perhaps we do not all realize that the first two million were largely made up from the ranks of college students, the younger professional men, and those who were not closely tied into the world's affairs. The call for 2,000,000 more men which was just issued will cut deeper into the ranks of industry than did the first call. That means that there can be no slackers in the office, the shop, the cab or caboose; no slackers in the mine or the factory; it means a full day, a full hour, and a full moment for us all. It means work and save, and that is our duty, and to you who lead and plan and direct, it means double duty.

I have consistently said that the men officering and operating the railroads, knew how, could, and would save fuel. It is simply a question of how to do the most with the means at hand. To take a skilled man out of service as an instructor, creates a demand for an unskilled or partially skilled man to take his place; to make extensive changes in locomotives, shops, coaling stations, etc., means heavy drafts on

labor and material. All this should be done, but done in an orderly way. The real issue is that of getting every man to do the things he knows best how to do, with the means at hand. Saving fuel means saving everything else chargeable to locomotive operation; it means the expenditure of skill that decreases boiler and machinery repairs, decreases maintenance costs, decreases overtime losses; the wasteful use of fuel means the opposite.

The trouble with the fuel end of the railroad where it is given any measure of consideration at all, is that it is generally looked upon as a mechanical department function, when in fact it really reaches into and overlaps every department of the railroad. The conservation of railway fuel begins at the mine, thence over the track scales, on to the coaling station, through the breaker bar into the pockets, thence to the tender and the furnace door, not to end at the stack mouth but to begin again at the drawbar and sweeping back it embraces the trainmen, the dispatchers, the yardmasters, the signal men, the men in charge of air brake maintenance, the men in charge of lubrication, the maintenance of way men, from the chief engineer down to the trackmen, the superintendent and his assistants. They too save fuel and waste fuel with the rest. The fuel job is an operating department job and just so long as it is looked upon as an annex of the locomotive department, just so long will its economic possibilities be dwarfed and stunted.

The man who is responsible for the operation of the road should seize this greatest of opportunities for increased efficiency by organizing a fuel department, drawing on the mechanical department for the best men it can spare, mechanical department training alone fitting a man for the most important work. This man should be big and broad enough to do justice to the mechanical department which has in times past been combed for results while other departments went free. To save fuel, work must not alone be done with the men in the cab and the shop, but with all the men on the whole line and back to the coal mine. This man I would call a Superintendent of Locomotive Operation and he should have an assistant for each seventy-five locomotives, such an assistant to be a man of the capacity of a first class traveling engineer to help cover the field I have mentioned. In addition a sufficient number of skilled firemen should be detailed as firemen instructors to admit of giving each new fireman a proper measure of training when road service begins. The fireman instructor should also be given charge of the work of training the fire cleaning force at terminals, which duty will bring him in touch with the real pulse of the locomotive end of fuel economy, the dirty fire. The motive power department may need one or more traveling engineers for work other than fuel economy; the superintendent may require one or more assistants to pursue investigations, etc., but these men should be apart from the locomotive operation organization whose function should be, the conservation of fuel in all its collateral relations.

The supervisors attached to the Fuel Conservation Section, the department I speak for, find in many places certain outstanding conditions requiring correction. I will enumerate a few only.

Things are never quite as well as the men who live with them daily think they are; for example; Nozzle and front end standards are not maintained; this is frequently due to front end leaks, stopped up flues and superheater tubes, dislocated brick arches, dirty boilers, etc. Try opening the front end of a dozen locomotives, then look down the stack.

The stationary steam plants of the average railroad are badly designed and indifferently maintained; air leaks in brick settings; cracks in fire walls and behind fire arches with short circuiting of gases; lack of stack dampers; an unwholesome disregard of radiative losses, both on boiler sheets and steam lines; leaking water and steam valves, no attempt made to use exhaust steam for heating feed water or

buildings; fuel supply exposed and wasted; no facilities for cleaning tubes, etc. I will not speak of the general disregard of the value of gas analyses and CO₂ determinations in the larger plants.

Open fires in switch and roundhouse yards—the best of lump coal used.

Overloaded tenders with coal littered all over coal chutes, roundhouse and freight yard tracks; look your hump yard over, it will surprise you.

Cars leaving coal chutes with from 500 to 2,000 lb. of coal in pockets.

Tenders that leak coal through the side and gangway and through holes around the grate rigging; shop tenders standing half filled with coal for weeks; road and yard engines that carry coal on sides of tank and over water cistern to mix with cinders and become valueless.

Caboose stored with lump coal, the stove red hot with the doors open; steam heated coaches cooled by opening windows and ventilators; switch shanties with open doors and red hot stoves; coal piled outside on the ground in a pile so profuse as to shout "welcome."

Badly made up trains, box cars moving in trains with open doors, increasing train haul resistance.

Excessive standby time at initial and destination terminals, resulting frequently from lack of co-ordination between mechanical and transportation men.

Wasteful firing of engines on roundhouse tracks; fine coal losses through grates when firing up engines, and the dumping of half consumed coal put in fireboxes just before engine is placed on cinder pit tracks.

A disposition to let the brick arch saving and the superheater saving carry distorted steam distribution, defective valve and cylinder packing rings, and dirty boiler losses.

Indifference to fuel and other losses chargeable to improper lubrication of moving parts, including the internal lubrication of the locomotive as well as freight train journals.

Train line leaks. Men who should know say freight train line leaks absorb ninety-five per cent of the air made by locomotive compressors and consume six million tons of coal annually; a six-pound per minute leak, under a fifty car freight train, consumes, when supplied by single stage compressors, 800 or 900 lb. of coal in ten hours; a fifteen-pound leak will require the service of two single stage air compressors and consume 2,600 lb. of coal in ten hours. I have reports of seventeen pounds leakage on the engine and tender, and sixteen pounds per minute under a train of 46 freight cars. The remedy lies in the repair shop and yard; with the switchmen who fail to cut hose by hand and in the crash and bang that takes place in switching and hump yards. The single stage compressor should give way to the cross compound using one-third the steam, and producing more air, with decreased radiative losses. Let me impress on you that the single stage air compressor with the air end running at a temperature of 200 to 400 degrees Fahr. is the most extravagant steam user ever constructed as measured by results obtained; this fact alone should be sufficient justification for reducing train line leakage losses.

The average cost of coal on locomotive tenders now exceeds \$3.50 per ton; the railroad fuel bill for 1918, including bituminous and anthracite coal and fuel oil, will total \$650,000,000. This represents 250 per cent of the fuel bill of 1915, the year preceding our entry into the world war. The issue, however, is not one alone of money; it is a question of volume, of enough coal and oil to go around, to keep the railroads, the steel plants, the munition factories, the ships supplied, to keep our millions of homes warm. England recently took 8,600 fighting men out of the ranks to mine coal, with more to follow; American soldiers will take their place.

The heroic women of France are rationed on fuel, a family

of five or six get a wash basin full of coal daily, with which to cook, to heat, to cleanse. Coal like liberty has been so free with us that we find it hard to attach a sense of value to it; the value is there, however; not alone a money value, but a value that flows from an insufficient supply and we must recognize the fact.

It is not the function of the Fuel Conservation Section to do the work of conserving fuel, that work like everything else connected with the operation of the railroads goes to make up the work of the men who man and officer the several lines. We will point the way and help you all we can.

Progressive managers are in many cases forming fuel saving organizations of the character outlined above; only a few have not as yet moved. On the whole the awakening to this situation is startling. I am arranging to make every paid railroad fuel inspector a representative of the United States Fuel Administration Inspection force, increasing their authority and usefulness. Where information reaches me that a railroad is being discriminated against in its fuel supply an immediate investigation is made and a remedy applied. The United States Fuel Administration is working hard for cleaner coal and the effort is bearing fruit. What we want is interest, human interest, individual endeavor, a certain and defined recognition of the fact that coal and fuel oil today, while more costly than ever before, have a value beyond price.

For the past few days the name of Lens, a coal mining town in northern France, has stood out sharply in the war news headlines. For three years, the contending armies have surged back and forth on the outskirts of this city, the center of the most important coal field in France. French guns stationed behind the refuse piles surrounding these deep coal pits yielded reluctantly to the enemy. The surrounding terrain is a grave yard, twenty-five thousand allied troops falling there in one battle. For what was this toll of human life? For coal. The Allies are in Lens again. When you hear the name of Lens, think of coal.

MR. QUAYLE'S ADDRESS

Robert Quayle, superintendent motive power and car department of the Chicago & North Western, spoke of the importance of the work of the traveling engineer and the necessity of having men who could handle it in a broad, thorough manner. The traveling engineer, if he is the right kind of a man, must be able to get others to respond to his efforts. To do this he should work with the idea of serving rather than dominating.

Touching on the problem of fuel conservation, Mr. Quayle said that the production of coal was not keeping pace with the demand. There is danger of a shortage which will slow up our manufactures. Every man must be thinking and working to conserve the fuel supply. Coal must be utilized to get the maximum result. To do that the locomotives must be kept in the best of condition. The traveling engineers should see that all necessary repairs are made before the locomotive leaves the roundhouse.

HOW CAN THE TRAVELING ENGINEERS BEST AID IN THE MAINTENANCE OF LOCOMOTIVES

BY F. P. ROESCH

Fuel Supervisor, Northwestern Region, U. S. Railroad Administration

There is no question but what the demand for power will be equally as great if not greater this winter than it was last, and to meet this demand it is imperative that all lend their best and united efforts to put and keep the power in the best possible condition.

Those whose duty it is to overhaul and maintain power are up against a hard proposition. Skilled shopmen are scarce and hard to get. The railway shops have been depleted by draft, enlistments and by mechanics entering other fields holding out the promise of a higher remuneration; therefore the time of every shopman is worth much more to the Railroad Administration than is represented in mere dollars and

cents. Every hour spent in doing unnecessary work, every hour spent in repairing an avoidable defect or breakdown, is just that much of a setback to another locomotive waiting to be turned out of the shop or roundhouse.

Here is where the traveling engineer can help in maintaining power. The first requirement will be unqualified and undivided loyalty to the United States Railroad Administration. Get the full meaning of this statement. Beyond doubt, during the coming winter it will be necessary to transfer power from one road to another as the demands of the traffic require. If a traveling engineer thinks and acts for his home road only, is it not natural that when he sees a locomotive lettered P. D. Q. Railway or even U. S. A., he will say: "That is not one of our engines, so I won't bother my head with it"? And does it not follow that his attitude will be reflected in the work of the engineers? It may extend even to the roundhouse men as far as the wipers.

Forget the X. Y. Z. Railroad and remember only the U. S. A., because one engine is just as valuable to the Railroad Administration as another engine, and all should receive exactly the same amount of care and attention on your part and that of the men under your supervision as the engines bought for and owned outright by the company directly employing you.

Remember that in order to correct a defect it must first be known. Terminal inspectors are invaluable and find many defects, but the real place to inspect a locomotive is on the road and in service. Suppose, for instance, a follower bolt was working out of a piston head, could any terminal inspection locate it? Are there not many other defects that only manifest themselves when the engine is running that no terminal inspection, no matter how thorough, can locate?

It is a short job to replace a follower bolt, but it takes time to patch a cylinder. If shopmen don't have to spend so much time repairing avoidable breakdowns they will have more time to make repairs due to normal wear and tear.

It is not clear that you can materially assist in maintaining power by carefully noting each defect in every engine you ride and in reporting it immediately, before it results in a breakdown?

There are at present 50 federal inspectors to cover 250,000 miles of railroad. When we look back and see what these 50 men have accomplished toward improving the general condition of all the locomotives in the United States, we can appreciate what 1,300 traveling engineers working along the same lines can do.

But even that is not all. You can do more yet. By your example multiply yourself fifty-fold.

After you have convinced yourself that you are working for the U. S. A. and not the X. Y. Z. Railroad, line up the men under your supervision in the same way. Show your men that all locomotives are U. S. A. locomotives, and that it is their duty to get the very best there is in them out of them; that when laying on sidings waiting for other trains, they should, if they would deserve the name of engineers in every sense of the word, get down and inspect their engines, tighten up any loose nut or bolt they may find, put a nail or piece of wire in place of any missing cotter or split key, fill a grease cup or set up a wedge, if necessary, or do anything else that they can do to help matters along, regardless of any contracts or agreements they may have relieving them of this duty. And have them make notes of any defects they cannot repair, and report them on arrival, even though they are not required to make work or inspection reports.

Think how much of the time of shopmen they can save by a little timely attention to such small details, and how at one stroke they can increase the number of federal inspectors from 50 to 65,000. The engineers are now giving us much in faithful and efficient service, but if the matter is put before them in the right light they will give even more. There are no slackers among them.

You can help by being optimistic. Next winter when things are coming tough, kicking or whining will not help matters. Therefore, radiate cheerfulness, smile and make the others smile too. Encourage the enginemen; when they make a good run or save a breakdown, tell them about it. If they are doing wrong, show them the right way, not in a fault-finding manner, but as Robert Quayle put it, "in a big brotherly way," so that the men will see you are trying to help them to help the cause.

But go farther yet with your encouragement. A kind word to an engine watchman or hostler helper may save a bursted branch pipe next winter. Above all things preach the doctrine of U. S. A., not only among road men, but roundhouse men also. You have no authority over roundhouse or shopmen, but do not hang back on that account. Visit the roundhouse, anyway, and cheer up the roundhouse foreman occasionally. He needs it and deserves it. If he has taken the slam or the blow out of an engine, following one of your reports, tell him about it. If a machinist has filed a brass or a truck man has packed a box and has done a good job, tell him. Let them know their work is noticed and appreciated. There is nothing that sets work back as much as all blame and no praise.

If the traveling engineer will work along these lines, put his whole soul and energy into his work, and encourage all others to do likewise, he can do as much toward aiding the United States Railroad Administration toward maintaining locomotives as a whole army of mechanics. Remember always that the man who does not at this time give all that is in him is as much of a slacker as the man who turns his back on the Hun in the trenches.

DISCUSSION

H. M. Curry (Nor. Pac.) spoke of the need of an esprit de corps among the enginemen in the present emergency, and stated that in his opinion nothing would be of more assistance in keeping locomotives in good condition and saving fuel than thorough wiping at terminals. Keeping the engines would not only facilitate inspection but would also make the working conditions more pleasant for the enginemen and incite them to greater efforts to keep the power in good condition.

J. B. Hurley (Wabash) spoke of the waste of fuel which often results from the improper use of the injector. He stated that in his opinion the injector should always be operated by the engineer. He spoke of the necessity of properly maintaining the wedges and binders. Well maintained wedges save the driving boxes and properly maintained binders will reduce the number of broken frames. The traveling engineers should do all they can towards keeping the locomotives in good condition.

One of the members spoke of the desirability of avoiding the unnecessary shifting of power due to the trouble experienced in operating classes of engines with which the men are not familiar. He cited the instance of a class of locomotives which gave so much trouble due to loose follower bolts that it was found advisable to remove the cylinder heads and inspect the pistons at the end of every round trip.

H. C. Woodbridge, fuel supervisor, Railroad Administration, called attention to the fact that it would barely be possible to get all the locomotives in good condition under the present circumstances. It is therefore essential that the roads face the conditions as they exist and make plans to utilize the motive power to the best advantage.

Several members spoke of the hearty co-operation received from the enginemen. The lodge halls of the brotherhoods had been used by the traveling engineers for meetings with the men. Appeals for economy in the use of fuel had met with a hearty response.

J. C. Petty (N. C. & St. L.) urged that the more experienced engineers should take upon themselves the duties

of the traveling engineers and by making close inspection of their engines and complete work reports enable the traveling engineer to devote his time to instructing new men.

Mr. Roesch in closing the discussion said that the traveling engineer belongs in the cab instructing the engine crew. He should see that it does what it can to properly care for the engine. The traveling engineer should work to his utmost covering as many locomotives as he can and to the best of his ability see that they are in proper condition for the engine crew to run. Time and material are of the greatest value to the nation at the present time. He spoke of the possibility of a general pooling of power, particularly if conditions arise similar to those of last winter. The men must be made ready for such an emergency. Pooled power has been operated successfully on some roads and there is no reason why it could not be as successfully operated on all roads. Locomotives transferred from one road to another may give trouble at first but if they are taken in hand promptly these troubles can soon be overcome. They must be overcome and the engines properly maintained for the sake of the nation which is now the paymaster for all railway men. It will cause inconvenience but the war creates inconvenient conditions.

CO-OPERATION OF TRAVELING ENGINEERS AND GENERAL AIR BRAKE INSPECTORS

[The full title of this report is "How Can the Traveling Engineers and General Air Brake Inspectors Best Co-operate to Improve and Maintain the Air Brake Service?"—EDITOR.]

It is hard even for those who have been in constant touch with railroad development to realize just how fast the tonnage handled by the railroads has been increased during the last few years, and what efforts have been necessary on the part of the railroads and manufacturers of railroad equipment to meet the requirements of safety, promptly and economically handling this increased tonnage. The increased weight of locomotives and cars, as well as the increased number of locomotives used to handle a train (as many as five locomotives are used on one train on some of our mountain roads), has resulted in a constant increase in the length of trains and the tonnage handled per train, all of which has exacted more care in handling and greater efficiency in the maintenance of air brakes.

The air brake manufacturers, to meet the more exacting conditions imposed on the air brakes, have made every effort to improve and change the equipment to meet the requirements. Although the improvement in brake equipment for both locomotives and cars has been rapid, it is doubtful if it has kept pace with the requirements, and a higher state of maintenance than was required a few years ago is now necessary if we expect to get the desired results.

As changes in road conditions take place, the traveling engineer, on account of being in close touch with the men handling equipment and with operating instructions regarding increases in tonnage and the length of trains, also the placing of power, is in a position to either notice or have his attention called to irregularities that interfere with good train handling. As a rule men handling equipment give their opinions freely as to the cause and remedy for troubles to the traveling engineer. Although many of these opinions finally prove to be worthless, they are all worthy of consideration until the real cause of trouble is found, and close co-operation on the part of the traveling engineer and general air brake inspector in the analysis of suggestions offered by men handling equipment and of their own observations regarding the cause of and the best methods of overcoming trouble, will result in intelligent conclusions as to the cause and prompt remedies being applied.

We believe that practically all air brake troubles that cause delay and damage to equipment are avoidable; also, that they are due either to a poor condition of maintenance

or improper handling. Where improper handling is the real cause, a continuation of the trouble is almost inexcusable, as most men handling equipment are glad to handle it properly if the right way is pointed out to them, and as the traveling engineer and general air brake inspector are looked to by the men for proper instructions, it follows that close co-operation regarding best methods of handling is absolutely necessary on the part of the traveling engineer and general air brake inspector. Where such co-operation does not exist it will be generally found that the men have little confidence in instructions given by either, and they will handle the equipment according to their individual ideas, which as a rule vary from the best methods to those that are held responsible for damage.

It is of the greatest importance that the air brake equipment on the locomotive be kept up to a high standard of maintenance, and if roundhouse forces are properly organized the equipment will be thoroughly inspected by competent men, and proper repairs made as soon after engines arrive as possible. However, it is a fact that many of the air brake troubles blamed to train equipment are due to a poor condition of maintenance of locomotive equipment, and it is also a fact that too many locomotives are allowed to make trip after trip with main reservoirs improperly drained, excessive pipe leakage, improper air pump lubrication, excessive pressure variations due to feed valve and governor defects, brake valves and distributing valves defective, etc.

All of these troubles have a tendency to defeat the best methods of handling, and are the direct cause of damage and delay that in many instances are blamed on train equipment. While direct responsibility for such conditions should fall on the roundhouse force, proper co-operation on the part of the traveling engineer and general air brake inspector would result in the men being educated to promptly note and report such conditions, which would result in assistance to the roundhouse force, and also to tracing trouble directly to its real cause, and promptly applying the remedy.

It is the general opinion of men coming in close contact with road delays that can be directly traced to air brake defects, that such delays are avoidable and in most cases can be traced to poor terminal inspection and failure to make proper repairs or to a poor general condition of maintenance. This applies particularly to freight service.

The incoming test of trains as a remedy for yard and road delays caused by air brake defects is one that has been advocated by general air brake inspectors for years, but up to the present time their recommendations have been useless. This fact may be due in part to their failure to make the importance of the incoming test realized by operating officials, but surely the mistake of allowing a car that arrives at a terminal or repair point with a defective brake, to be switched into an outgoing train, is as inexcusable as allowing a defective engine to remain in the roundhouse without inspection and discovering the defect after coupling to a train or after an engine failure occurs on the road.

The traveling engineer, more than any one else, realizes the value of prompt inspection and giving the repair force all possible time to make repairs on a locomotive, and he knows the relation that such inspection bears to engine failures and engine mileage during a given period; therefore we believe that if the traveling engineer and general air brake inspector would co-operate in keeping the importance of the incoming test before the operating officials it would result in a practical system of incoming inspection being adopted in all yards, that would materially decrease delays and damage to equipment and lading.

Brake pipe leakage is one of the most prolific causes of air brake troubles on the road, and although all of us very often hear the men handling equipment complain of brake

pipe leakage, it is seldom that we can find a man who has any idea of how many pounds per minute brake pipe leakage exists on the train he is handling. It is therefore our opinion that men handling trains should be educated to understand the condition of the brake pipe, and when necessary to make a report; a clear statement of the number of pounds per minute leakage should be made, instead of the usual report of "too much brake pipe leakage." Co-operation between the traveling engineer and general air brake inspector would result in a thorough knowledge of the actual brake pipe leakage conditions, and a thorough knowledge of such conditions in most cases would result in improvement.

It is probable that brake cylinder leakage is responsible for brake inefficiency more often than any other part of the equipment, and it is also probable that responsibility for such inefficiency is seldom traced to the cylinder unless leakage becomes excessive to the extent of practically making the brake inoperative. It is therefore apparent that brake cylinder maintenance should receive more attention than it does, and co-operation between the traveling engineer and general air brake inspector along this line should result in a more thorough knowledge of the actual conditions of brake cylinders, and a system of brake cylinder maintenance being adopted that would insure work being properly done at the time of cleaning and the proper kind of material being used.

The use of inferior low-cost material in air brake repairs is responsible for more or less air brake inefficiency, and under the present cost of labor there is no doubt that the use of such material is much more expensive than the use of the best material, even at a higher price. While the traveling engineers and general air brake inspectors do not as a rule have much to say regarding the purchase of material, we believe that their co-operation in keeping the attention of higher officials on the quality of material being used, would in many instances result in the best material being furnished, which in most instances would result in more lasting repairs being made which means a higher efficiency and lower total cost of maintenance.

It has not been the intent in preparing this paper to go into detail regarding the best methods of obtaining the desired results, as local conditions have much to do with the detail of maintenance of equipment, and the rules of most of the large roads already require the following of recommended practice as laid down by the Air Brake and Master Car Builder Associations. More close co-operation between traveling engineers and general air brake inspectors would assist in such rules and recommended practices being more closely followed, which would result in improving and maintaining the air brake service.

The report was signed by E. F. Wentworth, chairman, (New York Air Brake Company); W. V. Turner, (Westinghouse Air Brake Company); A. G. Huston, (Virginian); J. B. Hurley, (Wabash) and L. R. Pyle, (United States Railroad Administration).

DISCUSSION

The keynote of the discussion was that the traveling engineers and the airbrake inspectors must co-operate to the fullest extent. The duties of each of these positions are so extensive that it is impossible for each to excel in the field of the other. Airbrake problems must be referred to the airbrake men and train operation problems to the traveling engineer. A great deal of the trouble in handling trains is due to excessive train pipe leakage. This should not exceed eight pounds per minute and in any case it should not exceed the capacity of the feed valve to charge the line. By keeping train line leakage down the trains can be moved much faster over the division and less fuel will be used. Stuck brakes caused by train pipe leakage has made double-heading necessary in some cases. The leakage should be

traced back to the repair tracks and no car should be released until the air brakes are tested and repaired regardless of the cause for which the car was to be repaired.

A great deal of time will be saved and the equipment better maintained if a thorough test of the brakes is made when a train reaches a yard. On this incoming test minor repairs can be made by the inspectors and the cars requiring heavier repairs should be set out immediately for the necessary repairs. This will reduce the delay of the outgoing test. Locomotives have been found having a leakage of 16 lb. and this should not be tolerated.

A great deal of trouble is caused by the manipulation of the brakes. Many cases were reported where the brakes were not brought to full release before starting, an effort being made to release them with the engineer's valve in the running position. It is the duty of the traveling engineer to teach the enginemen properly to diagnose the air brake troubles in order that detail and explicit reports of repairs can be made. One of the most common causes of train pipe leakage is pulling hose apart and the ramming of cars together in switching yards. The former destroys the hose and the latter destroys the brake pipes and causes the joints to leak. The difficulty of operating passenger trains having P.M. and L.N. air brake equipment, with the supplementary reservoir of the L.N. equipment left in service, has been obviated on the Baltimore & Ohio by using only one train pipe reduction in making a stop, the first application being split to a 10 lb. reduction and then any amount of reduction is permissible. In giving instructions to the enginemen enough information should be included to show them the reasons for such instructions. Difficulties in obtaining proper and sufficient labor to repair the cars were mentioned but it is expected that the increase in wages will hold them in.

OTHER BUSINESS

At the opening session W. E. Brumble, in behalf of the Railway Equipment Manufacturers' Association, presented the Traveling Engineers' Association with a service flag having 20 stars. The flag bears one gold star for Lieut. J. Boyden Russell, who was killed in an aerial bombing expedition on the Italian front.

D. R. MacBain offered some suggestions for increasing the service secured from motive power. He dwelt particularly on the importance of the traveling engineers devoting all their time to improving the condition of locomotives and instructing enginemen in the proper methods of handling them. At the present time they are often required to devote a large share of their time to the investigation of minor matters of discipline to the exclusion of more important work.

At the closing session A. F. Duffy, assistant manager, Safety Section, United States Railroad Administration, gave a talk on the subject of reducing accidents and personal injuries on American railroads.

The secretary reported that the association now has over 1,300 members, and that over 200 members were admitted during the convention. During the past year the association has invested \$2,000 in Liberty bonds and has contributed to the American and the Canadian Red Cross. Cash balance in the treasury was nearly \$800.

The following officers were elected for the coming year: President, H. F. Henson, Norfolk & Western; first vice-president, G. A. Kell, Grand Trunk; second vice-president, W. E. Preston, Southern; third vice-president, L. R. Pyle, Railroad Administration; fourth vice-president, E. Hartenstein, Chicago & Alton; fifth vice-president, J. H. DeSalis, New York Central; treasurer, David Meadows, Michigan Central; secretary, W. O. Thompson, New York Central; executive committee—W. H. Corbett, Michigan Central; S. V. Sproul, Philadelphia, Baltimore & Washington; T. F. Howley, Erie, and F. Kerly, Baltimore & Ohio.

Chicago was chosen as the next place of meeting.

LIST OF EXHIBITORS

- Air Reduction Sales Company, New York.—Acetylene apparatus, oxygen and acetylene generator. Represented by R. T. Peabody, W. T. McCarthy and R. A. Sossong.
- American Arch Company, New York.—Represented by A. W. Clokey, R. J. Himmelfricht, J. P. Neff and T. Anthony.
- American Flexible Bolt Company, Pittsburgh, Pa.—American staybolts, American hollow staybolt iron, American rivets, American marine staybolts. Represented by R. W. Benson, W. F. Heacock, J. A. Trainor, C. W. Widmer, M. C. Gallister and A. J. Edgerly.
- American Steel Foundries, Chicago.—Models of the Simplex coupler, Simplex coupler pocket, Economy draft arm, Eclipse coupler yoke, Andrews side frame and Atlas safety guard and third point support. Represented by W. C. Wallace, H. J. Melchert, F. A. Martin, W. A. Wallace and B. C. Hooper.
- Anchor Packing Company, Chicago.—Packings, nut lock for air stuffing boxes. Represented by J. C. Weedon and J. A. McNulty.
- Ashton Valve Company, Boston, Mass.—Wheel press recording gage, air and steam gages, safety valves, safety valves. Represented by J. W. Motherwell, H. O. Fettinger and J. F. Gettrist.
- Baldwin Locomotive Works, Philadelphia, Pa.—Photographs of locomotives. Represented by C. H. Peterson and C. H. Gaskill.
- Barco Manufacturing Company, Chicago.—Engine tender metallic connections for air, steam and feedwater between engine and tender; Barco metallic steam heat connections for passenger cars, coach yards, stations and roundhouses; Barco air reservoir connections; Barco automatic smokebox blow-off fitting; Barco loose bolt, crosshead and slipper. Represented by F. N. Hard, C. L. Mellor, Charles Thomas and F. H. Stiles.
- Bird-Archer Company, New York.—Boiler chemicals. Represented by C. J. McGurn, R. P. Ford, C. A. Bird, J. L. Farland, T. A. Peacock, C. C. Shaw, H. E. Wheeler and J. M. Dooly.
- Buda Company, The Chicago.—Turbo-generator set, 500 watt capacity; headlight case and reflector. Both meet United States headlight requirements. Represented by M. A. Ross, J. W. Cleary and H. E. Bayley.
- Chambers Valve Company, New York.—Chambers throttle valve. Represented by Frank Clark, W. H. Bellmaine and E. Barnett.
- Commonwealth Supply Company, Richmond, Va.—Lewis power reverse gear. Represented by H. G. Lewis.
- Crane Company, Chicago.—Valves and fittings. Represented by Frank D. Fenn and Fred W. Venton.
- Dearborn Chemical Company, Chicago.—Represented by T. H. Price, O. H. Keymerer, W. S. Reed, T. H. Rose, Paul Bowen, I. H. Bowen and I. L. Beebe.
- Detroit Lubricator Company, Detroit, Mich.—Lubricator.
- Flannery Bolt Company, Pittsburgh, Pa.—Tate flexible staybolt. Represented by W. W. White, Charles Hyland and George Howard.
- Franklin Railway Supply Company, New York.—Franklin No. 8 firerod, Franklin automatic adjustable wedge, radial buffer, engine and tender trucks. Represented by J. L. Randolph, C. W. F. Coffin, C. T. Burkholder and S. J. Rosenfelt.
- Galena Signal Oil Company, Franklin, Pa.—Represented by M. M. Meehan, D. L. Eubank, P. H. Stack, L. Gleason, J. A. Graham, F. J. Walsh, C. McNair, G. E. McVicar, L. H. Palmer, W. O. Taylor and A. J. Fole.
- Garlock Packing Company, Palmyra, N. Y.—Packing.
- Garratt-Callahan Company, Chicago.—Magic boiler preservative. Represented by E. V. Sackett, W. E. Rollinson, T. C. McCollum and A. H. Hawkins.
- Gillespie & Co., A. W., Chicago, Ill.—Economy firebox door, Hendrickson journal bearing boring machine. Represented by A. W. Gillespie and J. S. Seelye.
- Hammitt, H. V., Troy, N. Y.—Type D Trojan superheat metallic packing. Represented by E. C. Sawyer.
- Henry Manufacturing & Grease Cup Company, Terre Haute, Ind.—Henry locomotive grease cup. Represented by Miss Mildred Netherton and Harlow Varney.
- Hulson Grate Company, Keokuk, Iowa.—Hulson locomotive grate. Represented by A. W. Hulson and J. W. Hulson.
- Hunt-Spiller Manufacturing Company, Boston, Mass.—Cylinder bushings, cylinder rods, piston heads and bull rings, valve bushings, packing, valve Tee rings, crosshead shoes and wedges, air pump bushings, side rod bushings. Represented by J. G. Platt, V. W. Elliot, E. J. Fuller, J. M. Monroe and C. F. Galloway.
- International Correspondence Schools, Scranton, Pa.—Represented by Jerome Edwards Metallic Packing Company, Chicago, Ill.—Metallic packing.
- Johns-Manville Company, H. W., New York.—Power plant specialties, insulations, J-M expander rings, J-M brake lining packing cups, steam traps and steam valves. Represented by T. E. Meek, J. C. Younlove, G. Christenson, J. M. Barrowsdale, F. C. Jacobs, C. E. Murphy, H. Flanagan, J. H. Trent, D. L. Jennings and E. H. Willard.
- Keystone Equipment Company, Philadelphia, Pa.—Wedge bolts. Represented by E. J. Shafer and E. J. Zinst.
- Leslie Company, The Lyndhurst, N. J.—Leslie steam heat regulators, Leslie electric headlight regulator and removable coupling nuts. Represented by S. Inglis and J. J. Cizels.
- Locomotive Feed Water Heater Company, New York.—Feed water heaters, boiler feed pumps. Represented by E. A. Averill and H. V. Jones.
- Locomotive Lubricator Company, Chicago.—Locomotive force feed lubricators. Represented by W. I. Schlocks, O. H. Neal and C. W. Rudolph.
- Locomotive Pulverized Fuel Company, New York.—Represented by A. H. C. Dalley.
- Locomotive Stoker Company, Pittsburgh, Pa.—Photographs of shop equipment and cab view of the Dunlap stoker, and the Dunlap of Virginia. Mallet No. 802. Represented by C. W. Allen, E. C. Haskins, J. J. Byrne, W. G. Clarke, O. B. Capps, W. S. Bartholomew, O. W. Detrick, T. J. Hanahan, C. E. Peterson, E. F. Milbank, E. Prouty and F. L. Wadsworth.
- Locomotive Superheater Company, New York.—Represented by George L. Bourne, F. A. Schaff, R. I. Van Meter, John Bell William Boughton, W. A. Buckbee, George Fogg, A. C. Loudon, B. G. Lynch, S. Macdonald, A. C. McLachlan, J. E. Moutrie, H. L. Ouley, R. M. Osterman, R. E. Porterfield, G. E. Ryder, G. E. Spenciger, H. F. Snicker, K. F. Stillwell, W. G. Tawse and C. M. Wickham.
- Long, Jr., Company, Charles R., Chicago, and Louisville, Ky.—Railway paints. Represented by Charles K. Long, Jr., S. W. Russell, W. H. Heckman and C. Turner.
- Manning, Maxwell & Moore, Inc.—Exhibiting Ashcroft gages. Consolidated safety valves, Hancock inspirators, boiler checks and other appliances. Represented by C. R. Brown and F. J. Wilson.
- Metal Thermit Corporation, New York.—Represented by J. W. Motherwell.
- Nathan Manufacturing Company, New York.—Injectors, non-lifting, lubricators; boiler check; combined stop valve; gage cocks; power reverse 3-way valve; coil sprinkler; balance lever starting valve, used in connection with injectors, water gages and cocks, globe and angle valves. (Government standard as applied to standardized locomotives.)

represented by W. E. Brumble, I. G. Arn, F. C. Davern, W. R. Walsh, Richard Welsh, H. L. Gettys and Herbert Ewan.

National Malleable Castings Co., Cleveland, O.—The Sharon coupler.

National Railway Devices Co., Chicago.—Shoemaker vertical firedoor. Represented by Jay G. Robinson and Milton M. Auerbach.

Ohio Injector Company, Chicago.—Ohio injector, U. S. Government standard non-lifting injector, Chicago lubricator, Chicago flange offer, Chicago automatic drift valve and Chicago water glass protector. Represented by F. W. Edwards, W. S. Furry, Frank W. Furry and A. C. Beckwith.

Oxide Company, Inc., Chicago.—Blow-off valves, hose-strainer, water glass protector. Represented by A. G. Hollingshead, G. S. Turner, Harry Vissering and W. H. Heckman.

O'Malley-Bear Valve Company, Chicago.—Multiplate valves. Represented by Thomas O'Malley, Edward O'Malley, J. C. Brown, J. N. Gallagher, Walter Morris and G. A. MacLain.

Paxton-Mitchell Company, Omaha, Neb.—Paxton-Mitchell metallic packing. Represented by Joseph L. Paxton and J. T. Luscombe.

P. olin Railway Service Company, St. Louis, Mo.—Represented by R. P. Le Veke, Joseph Sinker, Le Veke Wilcox and W. G. Newell.

Pilliod Company, New York.—Sentinel low water alarm, Baker valve gear. Represented by R. H. Weatherly, Fred E. Pilliod, W. H. Bellmaine, Edward Barnett, J. J. Donovan and K. Eklund.

Pocket List of Railroad Officials, New York.—Represented by C. L. Dinsmore.

Pyle National Company, Chicago.—K-23, E-2, E and M. turbo-generators; also the standard and two special type incandescent headlight cases with accessories. Represented by J. Will Johnson, William Miller, L. H. Steger and F. E. Foston.

Railway Review, Chicago.—Represented by H. A. Smith, C. L. Bates, J. M. Lammade and J. E. Gorizcon.

Sargent Company, Chicago.—Sargent safety water gages, Soerdge quick acting blow-off valves. Represented by George H. Sargent, P. W. Raymond and George S. Garren.

Simmons-Boardman Publishing Company, New York.—Copies of *Railway Age and Railway Mechanical Engineer*. Represented by R. E. Thayer, A. E. Sherman and F. H. Thompson.

Schroeder Electric Headlight & Generator Company, Evansville, Ind.—Standard U. S. turbo-generator, U. S. standard headlight case and reflector in operation, mounted interior set on ball bearings, parts and accessories. Represented by W. A. Carson, E. W. Jones, F. W. Edmonds and W. T. Manogue.

United States Metallic Packing Company, Philadelphia, Pa.—Models of piston rod and valve stem packing. Represented by M. B. Prevster, Elliot Curtis, R. R. Wells, Harry Flynn, Harry Hystop and L. B. Miller.

United States Rubber Company.

Vapor Car Heating Company, Chicago, Ill.—Steam hose coupler, reducing valve, hose clamps, stop valve, end train pipe valves, McLaughlin flexible steam joint. Represented by E. E. Smith.

Vissering & Co., Inc., Harry, Chicago, Ill.—Viloco firedoor, locomotive sanders, piston and valve stem packing, bellringer. Represented by Harry Vissering, G. S. Turner and W. H. Heckman.

Western Railway Equipment Company, St. Louis, Mo.—Lindstrom syphon. Represented by S. H. Campbell and R. L. Langtin.

Westinghouse Air Brake Company, Pittsburgh, Pa.—Represented by C. J. Olmstead, A. K. Holmyer, Lawrence Wilcox, L. M. Carlton, E. B. Farmer, I. A. O'Malley, V. Villette, F. W. Ainsworth, H. H. Burns and F. M. Nellis.

White American Locomotive Sander Company, Roanoke, Va.—Graham-White Perfect sander. Represented by James Frantz and W. H. White.

Wyoming Shovel Works, The, Wyoming, Pa.—Represented by G. E. Geer.

FUEL ECONOMY AT STATIONARY PLANTS

An enthusiastic meeting of railway men directly responsible for the consumption of fuel in the stationary plants on the railways under the control of the Railroad Administration was held at the Fort Dearborn Hotel, Chicago, September 9, under the direction of Eugene McAuliffe, manager, Fuel Conservation Section. The meeting was well attended and inspiring impromptu talks were given by representatives of the Fuel Administration, the Fuel Conservation Section of the Railroad Administration and railroad men.

Mr. McAuliffe in opening the meeting called attention to the great amount of fuel that will be required for the railways this year. At the best possible estimate this will amount to 166,000,000 tons, of which 16,000,000 tons will be used in other than locomotive fireboxes. This coal will cost on an average \$3.50 per ton which is 250 per cent of the average price in 1915. While from a purely financial standpoint all possible saving in fuel should be made, the most important reason is its scarcity. It is estimated that the country will be short 75,000,000 tons of soft coal and the railways, the largest consumers of fuel, must contribute a large amount to make up this shortage. Although much has already been accomplished in using fuel economically on locomotives there is practically a virgin field among the railway stationary plants. While no attempt was made by Mr. McAuliffe to go into detail regarding the manner in which fuel can be saved in these plants he called attention to the great importance of keeping steam pipes and boilers well lagged to prevent undue radiation of the heat. Particular attention was also called to the importance of pre-

venting all kinds of leaks. Piping extending for any great distance should have ample provision for expansion. Exhaust steam should be used for heating wherever possible. The buildings should be kept tight in winter.

Fuel must be conserved. The shortage of fuel in England has required that country to take 8,600 men from the army to mine more coal. Coal should be salvaged the same as scrap.

TALKS BY FUEL ADMINISTRATION REPRESENTATIVES

David Moffet Myers, advisory engineer, United States Fuel Administration, spoke of the work the Fuel Administration is doing; described its organization and offered freely the services of the 600 men in that department to help the railway men save fuel. He said that without question 50,000,000 tons of coal or 10 per cent of the country's consumption, could be saved by more careful operation of steam generating plants without any expenditure for additional equipment. He pointed out the fact that practicing fuel economy not only saved fuel but reduced greatly the demands on the railroads for transportation.

George R. Henderson, administrative engineer for the Fuel Administration in eastern Pennsylvania and who has had considerable experience on railroads, called attention to conditions as he knows exist. He opened his remarks with the slogan: "If we can't can the Kaiser, we can help make the can. And this 'can' is made largely of coal," he said. He described the questionnaire which was sent out by the Fuel Administration to all steam plants for the purpose of determining whether or not they were being operated to the best advantage. Accompanying this questionnaire was a poster which was to be bulletined in every power plant. On this poster was the recommendation that a daily record of the coal and water consumption be kept, in order that the men might have a check on the amount used. It suggested the use of draft gages for the purpose of detecting whether any excess air was admitted to the boiler. It recommended the cleaning of tubes and of treating the feedwater to prevent scale forming on the inside of the tubes. It pointed out that suitable insulation on steam pipes, heaters, drums, etc., at least two inches thick would save 80 per cent of the heat. It recommended the use of exhaust steam for heating feedwater, buildings, and other general work, pointing out that the exhaust steam from the engine contains about 90 per cent of the heat in live steam. The necessity for sufficient supervision was also touched upon.

Joseph Harrington, administrative engineer for Illinois, spoke of the necessity for considering the personal equation of the men who handle the fuel. He cautioned that particular attention should be given the small plant. There are so many of them that even though the waste at any individual plant may be small the accumulative effect will be very large. Any organization developed on the railroads should be large enough to give the small plants proper supervision. He advocated strongly a two-pen recording draft gage for boilers so that a continuous record of the manner in which a fire is handled could be obtained and the work of the fireman thus supervised. Mr. McAuliffe agreed with him thoroughly in this. Such a device Mr. Harrington explained, would also have considerable moral effect on the fireman. He would fire the boiler correctly for he would know that a record was being kept of his performance. He also spoke of the importance of weighing the coal in order that the fireman will get a better idea of what he is actually doing. It will give him an incentive to improve his work and that is an important point that should in no way be overlooked. Congenial surroundings are also necessary. A conveniently arranged plant, well ventilated and kept picked up and clean will give the fireman a certain amount of pride and self-respect which will be reflected in his work.

Osborne Monnett, engineer for the Fuel Administration, spoke briefly, calling attention to some of the important points that should be watched in the design and operation of boiler plants.

FUEL OIL MUST BE CONSERVED

Nelson G. Phelps of the Oil Division of the Fuel Administration spoke on the fuel oil situation. He said that the time had now arrived when very serious consideration must be given this product. Oil is needlessly wasted. The Bureau of Mines, a short time ago, estimated that 40,000,000 barrels, or 1,680,000,000 gallons, of fuel oil were wasted yearly due to improper operating methods. It is very easy to waste the oil when it is being burned and it is here that a vast saving must be made. The country is facing a shortage of 29,000,000 barrels and for the last six months it has been necessary to draw from the storage supply.

Improper combustion of the fuel oil is responsible for the greatest waste. There should be some one made responsible for fuel oil economy and detailed to instruct the furnace operators in the use of the oil torch. Proper burners should be used. By far the majority of homemade burners are wasteful and it would be decidedly better to purchase a burner that has been designed correctly. Too often the fundamentals of burner construction are not understood. Better efficiency will be obtained with oil heated to 110 deg. before it enters the burner. The Fuel Administration is planning to publish some educational matter on economical fuel oil consumption which will be free for those handling fuel oil.

A WORD FROM FUEL SUPERVISORS

Various representatives of the Fuel Conservation Section spoke calling attention to the more important defects found around the railway stationary plants. By far the most common is improperly lagged steam pipes and boilers, excessive leakage from both air and steam lines, and improperly maintained boiler settings. Mr. Roesch presented some interesting figures showing that with coal at \$3.50 per ton in the furnace, steam at 150 lb. pressure leaking through a $\frac{1}{2}$ -in. hole would waste \$3,340 per year; through a 1 $\frac{1}{2}$ -in. hole \$1,330 per year. Air at 100 lb. pressure with coal at \$2.00 per ton leaking through a 1 $\frac{1}{16}$ -in. hole will waste \$2.89 per month, and through a 1-in. hole, \$741.82 per month. It was stated generally that positive and absolute neglect was responsible for the greatest wastes. In one case a road was extremely short of water at a certain point, and at the same time was wasting 26,000 gal. through leaky valves. Piping should be above ground in order that leaks can be located and stopped. A case was reported where a set of 9-in. locomotive air compressors was used for furnishing air at high pressure to the shop for tools, while a large shop compressor was used to supply air at a lower pressure to the yards. The shop compressor was not used to capacity and the two methods of producing the air were used simply to give a high and low pressure line. With a reducing valve the shop compressor could furnish air for both the shop and the yard.

In some territories where coal has been very cheap it has been difficult to make the men appreciate the value of fuel, but with the extreme shortage throughout the country they are beginning to realize the necessity for economy and while there is a lot to be done in educating these men they are giving their support and co-operation. The fuel supervisors are holding staff meetings at the important terminals. Their attention is not restricted entirely to the mechanical department; the transportation department is in a position to save a large amount of fuel, and men from that department are included in the meetings. Particular stress was laid on what coal means to this nation and to all of the Allied nations in winning the war. If for the lack of it this country could not do the full measure of work that will be required of it, the

length of the war will be increased, and that means that thousands of our boys will be unnecessarily sacrificed.

OTHER SPEAKERS

There were among other speakers at the meeting, H. T. Bentley, superintendent of motive power, Chicago & North Western, who told how necessary it was to stir up the enthusiasm of the men in the practice of fuel economy.

Mr. Anderson, of the Milwaukee Light & Power Company, Milwaukee, Wis., spoke of the success with which pulverized coal has been used in the power plant of that company under stationary boilers. Boiler and furnace efficiencies of over 80 per cent have been obtained with the pulverized coal, the net efficiency being greater than that obtained with the automatic stokers. The Locomotive Pulverized Fuel Company's apparatus was applied last May, and after changing the design of the furnace to adequately meet the new conditions imposed by this method of combustion no difficulty has been experienced with the proper operation of the plant. Mr. Anderson made it clear that in the design of the furnace lay the secret of success in using powdered coal. He spoke very enthusiastically of the possibilities of this method of firing stationary boilers.

The advantages particularly referred to for this method were the constant degree of efficiency, the fact that constant critical attention was not needed as in the case of stoker or hand firing methods and the ease of control of the fire. The waste of fuel accompanying the banking and cleaning of fires is eliminated. At the plant in question which has peak loads night and morning this feature was of particular importance. It was possible to shut a boiler down at night and by keeping the dampers closed to conserve the heat of the brick work in the furnace, to start the fire in the morning from the heat of the brick, the steam pressure having dropped but little. To operate this system most successfully a sufficiently large installation should be made to warrant a pulverizing plant of sufficient size to bring the cost of preparing the fuel down to a reasonable figure.

Mr. Maddox, of the Missouri, Kansas & Texas, told of the experience that road had with this method of burning fuel at its Parsons, Kans., plant. A sufficiently large furnace volume and the proper baffling of the boilers is very necessary. He believed that this method of burning fuel had come to stay, particularly in stationary plants. Lignite has been used with especially good success although it was fed to the boiler with seven per cent moisture.

C. A. Brandt of the Locomotive Superheater Company called attention to the fuel waste, caused by carelessness and ignorance, such as neglect of washing and scaling boilers, soot blowing, attention to proper damper regulations, condition of fuel bed, air leaks in boiler setting, steam leaks in pipes, etc. This waste is, undoubtedly, very great, particularly among the small and isolated steam plants of the railroads. It should be drilled into the minds of every man from top to bottom that steam and fuel wastes must be eliminated, no matter how small. We must not stop at this, however, for the waste caused by faulty operation is comparatively small as compared with the inefficiencies caused by incorrect designs of power plants and faulty or obsolete construction. Careless operation is bad whether it occurs in a poorly or an efficiently designed plant, but it is just as much a crime to operate a poorly designed plant, when its economy can be greatly improved by the installation of apparatus and devices that we know will produce a definite and positive fuel saving. The efficiency of a steam power plant is fundamentally that of design, and I believe it is conservative to state that for any plant, the economic results are probably 85 per cent due to design and construction, and 15 per cent due to operation under normal conditions.

While material is scarce, man power is infinitely more

scarce, and we must remember that the installation of modern appliances in power plants, such as stokers, ash handling devices, feedwater heaters and superheaters will not only save coal, but they will also save labor.

In regard to the use of superheated steam there is not a man here who is not familiar with the wonderful performance which the locomotive superheater has produced towards increased fuel and water economy and increase in power of our steam locomotives. The locomotive superheater has made possible great savings, increased tonnage and fuel economy, yet, with all this knowledge, and with the knowledge that the superheater will produce equal economies in stationary plants, very few railroad shops or engine house power plants are

equipped with superheaters today. I believe I am safe in saying that there are not more than a score of engine house power plants equipped with superheaters.

A correctly designed superheater will not only improve the over-all efficiency of the boiler plant where steam is produced, but what is infinitely more important, it will save steam in its utilization. Condensation in steam lines could be practically eliminated, due to the reserve heat stored in the steam, as well as due to the lower conductivity of superheated steam. In roundhouses where locomotives are fired up from the house blower, there will also be a considerable saving due to the fact that the specific volume of superheated steam is greater than that of saturated steam.

RAILROAD ADMINISTRATION ACTIVITIES

News of the Month from Washington and Various Regions Pertaining to the Mechanical Department

W. S. CARTER, director of the Division of Labor, has issued a circular regarding methods of adjusting differences regarding labor, in part as follows:

In the adjustment of differences of opinion, not involving rates or amount of wages, or hours, that arise in the relations between the officials and employees, which differences are to be expected, sincere effort should be made to reach a common understanding without the necessity of reference to the director general, or to the Division of Labor. Where such controversies are not so adjusted, or where questions involving rates or amount of wages or hours are raised, the following methods will be adopted:

(a) Requests by employees for increases in wages, in addition to increases provided for in wage orders, will be filed *only* with the Board of Railroad Wages and Working Conditions, to which board has been assigned the duty of hearing and investigating such matters, as provided in Article VI of General Order No. 27.

(b) The method of securing interpretation of wage orders is prescribed by the director general in Supplement No. 6 to General Order No. 27, and the prescribed method should be followed in cases involving interpretations of wage orders.

(c) When employees are represented by railway boards of adjustment, the procedure as to all controversies within the scope of their duties will be as directed in general orders creating such boards. The fact that certain employees are not represented by railway boards of adjustment will in no manner deprive them of any of the benefits accruing from such boards. An assistant to the director of the Division of Labor has been appointed, and a staff of representatives has been organized, for the special purpose of rendering the same service to such employees as though represented by a railway board of adjustment. Boards of adjustment have been created by understanding with the larger organizations of employees, for the convenience of handling such matters and to relieve the director of the Division of Labor of adjusting same. It is not practicable to create railway boards of adjustment, except for the larger organizations of employees.

(d) Requests for adjustments in wages by employees *not* represented by railway boards of adjustment, which requests are based upon existing practices or adjustments reached through former arbitrations and settlements, will be presented to the proper officials of the railroads, and negotiations will be conducted in the usual manner up to the chief operating officer, or officer designated by him. Should no agreement be reached, and it appear to be necessary to take the matter further, a joint statement of facts (in duplicate) will be prepared by the representatives of the employees concerned and the proper officials of the railroad, and submitted to the director of the Division of Labor of the United States Railroad Administration. Attached to such joint statement of facts will be such brief arguments by both parties to the controversy as is believed desirable by those concerned. When an adjustment is not then reached through correspondence, a representative will be assigned to investigate, and if by his assistance no agreement is then reached, the matter in controversy will be referred again to the director of the Division of Labor.

(e) Personal grievances or controversies arising under interpretation of wage agreements, and all other disputes arising between officials of a railroad and its employees *not* represented by railway boards of adjustment, will be handled in the usual manner by the individual, his representative, or by committees of employees, up to and including the chief operating officer of the railroad, or officer designated by him, when, if an agreement is not reached, the chairman of the committee of employees and the officer of the railroad will refer the matter to the director of the Division of Labor, in the same manner as provided in Paragraph *d* of this circular.

(f) When an employee, or class of employees, is not represented by committees, and negotiations cannot be conducted in the usual manner,

matters of complaint will be taken up with the proper officials of the railroad. When such employee or employees desire to appeal to the director general, a complete statement of the cause of complaint will be filed by such employee or employees with the director of the Division of Labor. When an adjustment is not reached through correspondence, a representative will be assigned to investigate, and if by his assistance no agreement is then reached, the matter in controversy will be referred again to the director of the Division of Labor.

(g) General Order No. 8 suspended negotiations for revision of schedules or general changes in conditions affecting wages and hours pending decision of the matter by the director general, which was accomplished by General Order No. 27. No order has since been issued either prohibiting or directing that negotiations for revisions of working conditions be undertaken. This matter is left to follow the usual course, except that all requests for increases in wages, reduction of hours, or special rates for overtime will be taken up directly with the Board of Railroad Wages and Working Conditions. Where working conditions are not agreed upon by committees of employees and the officials of the railroads, a joint statement of the points at issue will be prepared and filed with the director of the Division of Labor, attaching thereto such brief arguments as may be desired. When an adjustment is not then reached through correspondence a representative will be assigned to investigate, and if by his assistance no agreement is then reached, the matter in controversy will be referred again to the director of the Division of Labor.

Nothing herein contained has reference to employees of railroads not under federal control.

RULES FOR SUBMISSION OF NEW DEVICES

The Division of Operation has issued a circular prescribing the following rules to be observed in submitting new devices or inventions to the Railroad Administration for investigation:

Any person desiring to submit any apparatus or device to the United States Railroad Administration at Washington, for the purpose of having it passed upon and investigated, should forward complete specifications and detail drawings, showing fully and clearly the construction, application, and method of operation of said apparatus or device. The drawings should be made of convenient size for handling and filing, and drawings not larger than 8 in. by 10½ in. are preferred. Large drawings or prints must be multiples of this size.

The specifications and plans should be accompanied by a statement showing the following:

1. Name of appliance or device.
2. Name and address of proprietor.
3. Number and date of United States patent or patents.
4. Purpose of the appliance or device.
5. Brief statement of how the purpose is carried out.
6. General description.
7. Statement of relation to other appliances or devices.
8. Name of railroad or railroads on which used or tried and length of time in use.
9. Name of town, district, or railroad division where used or tried.
10. Name of railroad officers of whom inquiry may be made.

All plans, specifications, drawings, and other descriptions which are furnished for examination become a part of the

United States Railroad Administration's records and may be retained in its files.

When examination has been completed the papers furnished for such examination will not be returned; for that reason original patents, tracings, or other papers of that nature, which may be of particular value to inventors or proprietors, should not be furnished; instead, copies of patents, blueprints, or other descriptive papers of which duplicates can be obtained by the proprietor should be sent. The United States Railroad Administration can furnish no protection of the inventor's or proprietor's rights in any device submitted; therefore, plans should not be submitted until the rights of the inventor or proprietor are fully protected by patent or otherwise.

It is not necessary to submit models of devices. If for any reason it is desired to do so, however, models may be furnished, provided the proprietor pays all transportation charges. After examination models will be returned if the proprietor so requests, but this will also be done at the proprietor's risk and expense; otherwise models will be destroyed. In every case, however, whether or not models are supplied, complete detailed plans and specifications must be furnished; no report will be based on examination of a model alone.

When complete plans of any appliance or device have been furnished they will be placed under examination; after this examination has been completed the person submitting the device will be informed of the results thereof and the conclusions reached.

Arrangements for tests will not be made until an examination of plans discloses the necessity or desirability of conducting a test under service conditions. In case a test is to be made the apparatus must be furnished, installed, and operated without expense to the government.

Correspondence regarding matters of this nature should be addressed to United States Railroad Administration, Frank McManamy, assistant director, division of operation, Washington, D. C.

Nothing in the foregoing is intended to prohibit any railroad from testing and developing devices invented by its employees, or testing other devices which, in the opinion of the officers of the railroad, have sufficient merit to warrant it.

DEFERRED CLASSIFICATION FOR RAILROAD EMPLOYEES

Instructions that the federal managers give their active personal attention to make sure that deferred classification in the new selective service draft is properly claimed for railroad employees that are necessary and also that no such claim is made where it can reasonably be avoided were telegraphed to the regional directors on September 10 by Walker D. Hines, assistant director general. The following list of employees covers those affected by the order:

General officers, master mechanics, roundhouse and shop foremen, machinists, blacksmiths, boiler-makers, tin and copper-smiths, pin-fitters, electricians, freight car and passenger car repairmen and inspectors, respective helpers and apprentices of all the foregoing, chemists, locomotive inspectors, gang leaders, superintendents and assistant superintendents, trainmasters and assistant trainmasters, train dispatchers and directors, yardmasters and assistants, road foremen of engines and assistants, traveling engineers, firemen instructors, locomotive engineers and motormen, locomotive firemen and helpers, conductors, brakemen and flagmen, train baggage-men and express messengers, yard foremen and helpers, hostlers, engine-housemen, telegraphers and telephoners, block operators, telegraph clerks, engineers of maintenance of way, division engineers, roadmasters, field engineers, supervisors, construction foremen, foremen on track work (generally known as section foremen), bridge, building and water service foremen, bridge building, shop and wharf carpenters, signal maintainers, and telegraph and telephone maintainers.

SPEED UP LOCOMOTIVE REPAIRS

Director General McAdoo has instructed the regional directors to get the following message to every machine shop and roundhouse in their territories:

"General Pershing needs more locomotives in France to keep the big American smash going until the kaiser is pushed across the Rhine. The only way we can give General Per-

shing the locomotives he needs is for the railroads of the United States to take as few new locomotives as possible and thus permit the locomotive builders to send their product to France.

"We can not do without new locomotives unless we keep our locomotives in repair and moving all the time. I make a special appeal to every railroad mechanic and workman to do his level best to turn the locomotives out of the shops quickly and to keep their wheels turning on every railroad of the United States. Here is a direct way in which every man of you can help Pershing and his heroic soldiers and make certain the early defeat of the kaiser."

MECHANICAL STANDARDS ADOPTED

The Committee on Standards for Cars and Locomotives at its meeting last week adopted most of the specifications and general designs which had previously been approved for the proposed standard 70-foot baggage cars and for the proposed 60-foot cars, although the matter of truck design was not definitely decided. Specifications for the 70-foot car are now in the hands of the purchasing committee which is expected to ask for bids shortly. It is expected that orders for about 1,500 cars will be placed. Revised specifications for the lighting equipment, to which there had been some objection on the part of the lighting specialty companies, were adopted on the recommendation of a sub-committee after consultation with six prominent electric lighting engineers. The committee also has under consideration general instructions governing betterments to freight cars.

The committee gave consideration to the use of substitutes for steel for headlining of baggage cars, eliminated fish racks from the 60-foot cars, appointed a committee to make a special study of the use of folding devices and began work on proposed standard rules for the inspection of spark arrester devices in locomotive front ends and for the inspection of ash pans to insure greater fire protection. The committee also recommended the M. M. standards for tinware.

FUEL CONSERVATION AT STATIONARY PLANTS

On September 25, fuel conservation circular No. 14 was issued by the Fuel Conservation Section, covering the uses of fuel at railway stationary plants. About 17,000,000 tons of coal will be consumed in these plants on the roads in the United States and its cost, delivered to the furnace door, will be approximately \$60,000,000. The attempt to conserve the fuel used in these miscellaneous power and heating plants is apt to be relatively more fruitful than the efforts directed toward locomotive fuel consumption, because the general efficiency of small isolated plants is usually much lower than that of the locomotives and they are ordinarily subjected to less thorough supervision. The circular mentions many methods by which savings can be most readily affected in respect to the design and equipment of the plants and their maintenance, and to the methods of operation.

GARNISHMENT OF WAGES PROHIBITED

General Order No. 43 was issued September 5, prohibiting the garnishment or attachment of the wages of employees under the jurisdiction of the Railroad Administration.

DELIVERIES OF STANDARD LOCOMOTIVES

Of a total of 382 locomotives delivered to the railroads from August 1 to September 21, inclusive, 127 were of the U. S. R. A. designs being distributed as follows:

Baltimore & Ohio.....	37	Light	Mikados
Central of New Jersey.....	10	Heavy	Mikados
Chesapeake & Ohio.....	10	Heavy	Mikados
Chicago & Eastern Illinois.....	15	Light	Mikados
Chicago, Milwaukee & St. Paul.....	25	Heavy	Mikados
Lake Erie & Western.....	7	Light	Mikados
Lehigh & Hudson River.....	4	Light	Mikados
Pittsburgh & West Virginia.....	3	Light	Mikados
Union Pacific.....	6	Light	Mikados
Wheeling & Lake Erie.....	10	Heavy	Mikados

ORDERS OF REGIONAL DIRECTORS

Obsolete Freight Car Equipment.—The Northwestern regional purchasing committee asks railroads under its jurisdiction to report any freight car equipment which they contemplate retiring so that the War Board of Electric Railways may determine whether it can be used on electric lines.

Dismantling of Freight Cars.—The Southwestern regional director announces that when the cost of repairs to freight equipment exceeds the amount allotted to be expended for that purpose, the federal manager or general manager may authorize in writing that the cars be dismantled. Before such cars, or cars which are not worthy of repairs, are scrapped the regional director advises that they should be set apart for inspection by the corporation officers who will determine their final disposition.

Conservation of Fuel.—The Southwestern regional director quotes a letter from Eugene McAuliffe, manager of the Fuel Conservation Section of the Railroad Administration, recommending that cinder pit forces, car riders in switch yards and other employees be prohibited from making open fires from lump coal taken from cars and engine tenders. He suggests that when a fire is actually necessary a small shelter house with a stove be installed, thereby reducing the consumption of coal to a fraction of that used in the open fires.

The Hazard of Smoking.—Emphasis is placed on the necessity of prohibiting smoking on railroad property where inflammables are handled. Federal and general managers are asked to issue instructions prohibiting smoking in shops, coaling stations, piers, warehouses, storehouses, freight houses and offices, including record rooms, and around freight platforms and all places where inflammables are handled or stored. Watchmen, guards, officers and other employees in charge of property must see to it that the rule is enforced.

Salary Increases to Subordinate Officials.—In circular 28, dated August 31, the Northwestern regional director announces salary increases to subordinate officials, effective August 1.

Road foremen of engines, traveling engineers and traveling firemen will receive an increase of 25 per cent with a maximum of \$250 per month.

Railroads are asked to submit recommendations for increases in the rates of pay of superintendents, master mechanics, etc., and these recommendations will be acted upon promptly upon receipt.

Rates of Pay to Piece Workers.—The Northwestern regional director outlines the practice which will be followed in applying the provisions of General Order 27 and its Supplement 4 to piece workers. This class of labor will receive for each hour worked the same increases per hour as have been awarded to the hourly worker engaged in similar employment in the same shop. Piece workers, like other workmen, will be subject to the minimum allowances, specified in Supplement 4, and the provisions for the payment of time and one-half time for overtime, including Sundays and the following holidays: New Year's Day, Washington's Birthday, Decoration Day, Fourth of July, Labor Day, Thanksgiving Day and Christmas. Railroads having the piece work plan in effect for car or locomotive repairs are requested to submit to the office of the regional director their recommendations as to any further increase in piece work rates which should, in their opinion, be made.

Maintenance of Engine Terminals.—The Eastern regional director orders that to insure proper condition of engine terminals for the winter, repairs be made to roundhouse roofs, windows, doors, heating pipes, lighting systems, etc., November 1. Shelter should be provided for those employees whose occupations expose them to the weather, such as ash-pit, turntable and coaling forces, in order to protect the men, and by making comfortable provision help insure retention of sufficient force. Machinery of coaling plants, turntables, etc., should be inspected and repaired and spare parts provided to insure uninterrupted service.

Headlight Requirements on Switching Locomotives.—The Eastern regional director states that it has been determined that when necessary to make changes in headlights on switching locomotives to meet the requirements of the law, or on account of renewals, they will be equipped with headlights of the incandescent type with a turbo-generator and a bulb of suitable wattage.

Purchase of Rolling Equipment.—The Northwestern regional purchasing committee has furnished instructions to purchasing agents on the purchase of rolling equipment, such as locomotives, cars, coaches, etc. When an aggregate purchase for equipment, the capital expenditure for which has been duly approved, is estimated to cost \$100,000 or more, an order in triplicate should be sent to the regional purchasing committee with copies of plans and specifications, so that the matter may be submitted to the central advisory purchasing committee for purchase.

Such equipment amounting in the aggregate to less than \$100,000 should be purchased by the individual road, subject to the approval of the regional purchasing committee. Proposals covering such equipment should be tabulated and sent to the regional purchasing committee for approval with complete specifications, blue prints, and other details, accompanied by recommendations as to acceptance and reasons therefor. Equipment purchased by individual roads should as far as practicable comply with the equipment standards of the Railroad Administration.

Surplus Bar Iron on the Great Northern.—The Northwestern regional purchasing committee states that the Great Northern has a surplus of bar iron which is available for immediate shipment. Roads in the vicinity of Duluth, Minneapolis and St. Paul requiring iron are asked to draw on this stock before placing orders elsewhere.

Sill Steps for Disposal by the Soo.—The Northwestern regional purchasing committee announces that the Minneapolis, St. Paul & Sault Ste. Marie has 4,800 left-hand single freight car sill steps and 1,800 right-hand double freight car sill steps for safety appliances on box cars available for disposal to other roads. E. T. Stone, purchasing agent of the Soo line at Minneapolis, will supply further information concerning this material.

Surplus Material for Disposal by S. P. & S.—The Northwestern regional purchasing committee announces that the Spokane, Portland & Seattle has for disposal at its Portland shops material including angle bars, various sizes of new galvanized corrugated culvert pipe, four-point Pierce transposition J. brackets, new caboose cupola lamps, several thousand feet of new circular loom, several thousand feet of cable and a number of miscellaneous items.

Conservation of Scrap Car Wheels.—The following suggestions have been offered to the regional director by H. B. Spencer, chairman, Central Advisory Purchasing Committee: "The need for both new and scrap cast iron wheels is so great that I recommend instructions be issued to all railroads in your region that immediate and effective action be taken to utilize every second-hand and scrap car wheel available. We will require 687,600 chilled cast iron wheels for 87,000 cars and locomotive tenders for the U. S. Railroad Administration, in addition to what is required for the overseas' service. In order to produce these wheels, we must furnish at least 55 per cent old car wheels. With charcoal pig iron available it would have only been necessary to furnish 25 per cent old wheels in the mixture, but charcoal pig iron is unobtainable and we must make up the deficiency with old car wheels. Every railroad acquires and has on hand large quantities of trucks, wheels and axles, which are not serviceable and should be dismantled. In nearly every case a usable wheel or axle will be procured and in all cases scrap wheels will be obtained. A vigorous campaign requiring every railroad to dismantle all unserviceable trucks and press off every wheel from the axles is the only thing which will relieve the present situation."



U. S. R. A. STANDARD BAGGAGE CARS

The First Cars to Be Designed by the Government
for Passenger Service — All Steel Construction

THE United States Railroad Administration for some time has been working on the designs of two standard types of baggage cars, to be 60 ft. and 70 ft. long, respectively. These cars are of steel construction throughout, with the exception of the floor, and are generally similar in

The underframe is made of fishbelly center sills of the built-up type and Z-bar side sills. The center sill webs are of 5/16-in. plate, spaced 16 in. apart and reinforced top and bottom with 3½-in. by 3½-in. by ¾-in. angle flanges. At the top these angles are applied on the outside of the web plates only, while at the bottom they are applied both outside and inside. The center sill construction also includes a top coverplate 15 in. wide by ½ in. thick. At the deepest section the sills measure 26 in. over the flanges. This section

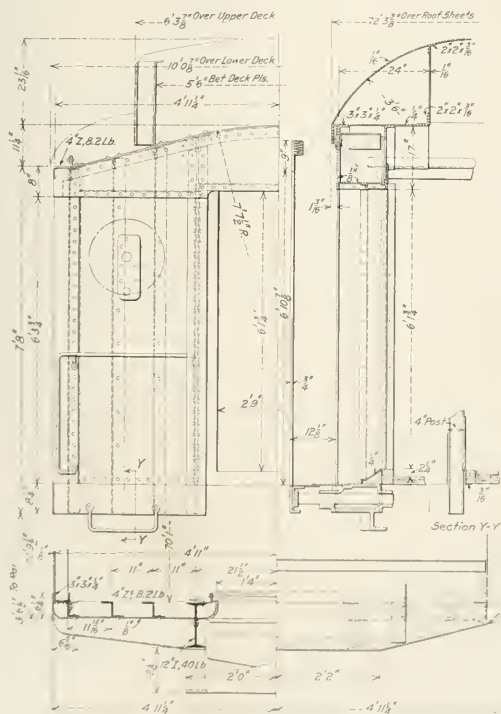

Arrangement of Built-Up End Construction for the 70-Ft. Standard Baggage Car

design. The side elevation and floor plan illustrated are for the 60-ft. car, while the details shown are those incorporated in the design of the 70-ft. car. The designs meet the Railway Mail Service requirements as to strength and in some respects are stronger than is called for by the Post Office specifications.

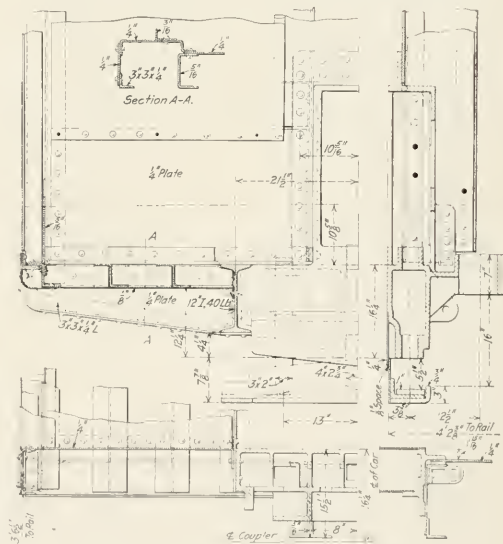

Platform Arrangement—Built-Up Construction

is maintained for a distance of 11 ft. 6 in. either side of the transverse center line, at which points are located the main transverse members. At these members the reduction in the depth of the section begins and reaches the minimum of 12¾ in. over the flanges at the back side of the double body bolsters. The principal transverse members are built up of ¼-in. single flanged diaphragms with fillers of the same thickness between the sills, and have continuous top coverplates 9 in. wide by 5/16 in. thick. A ½-in. by 6-in. plate, about 55 in. long, is riveted to the bottom flanges of the dia-

phragms, the center sill filler, and to the center sill flanges.

The bolsters and end construction of the underframe may be either built-up or of unit cast steel construction. In the

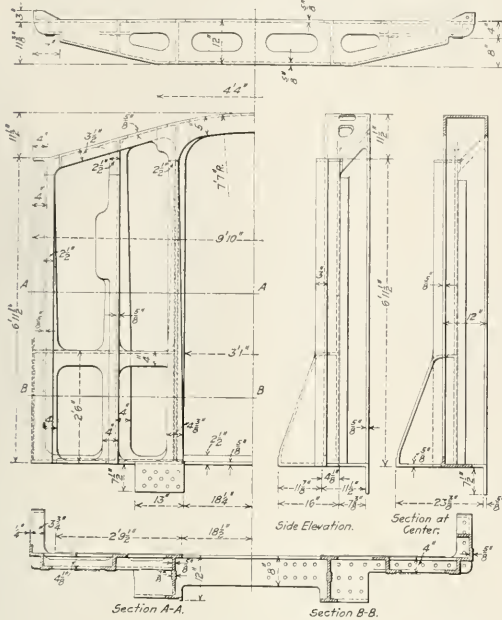

Details of the Cast Steel End Frame for the Railroad Administration Standard Baggage Cars

built-up underframe the center sills extend through to the end of the car body, the spring buffer casting being riveted between

to the flanges of these members, the side sills and the center sills. From a point 16 3/4 in. forward of the front transverse member of the bolster to a point 24 1/2 in. back of the rear transverse member, the center sills are closed by a 3/8-in. bottom coverplate. The lower flanges of the transverse members are reinforced by 1/2-in. by 8-in. plates, which are continuous from side sill to side sill. Side bearing supports are provided by 6-in., 14 3/4-lb. I-beams, placed longitudinally between the transverse members of the bolsters, 3 ft. 9 1/2 in. on either side of the longitudinal center line of the car.

The side sills are 6-in., 15.7-lb. Z-bars, with the lower flanges turned out. A 3 1/2-in. by 3-in. by 5/16-in. angle, with the short leg turned up, is riveted to the lower flange of the Z-bar, the face of this angle serving as a means of attachment of the outside steel sheathing of the car.

Alternate types of construction are provided for the end frame of the car. This may be either a unit steel casting or built up of structural sections. The details of the cast steel end frame are shown in one of the drawings. The built-up construction is designed to be of equal strength to that of the cast steel end, which is stronger than required by the Railway Mail Service specifications. The main vertical members are 12-in., 40-lb. I-beams, framed into the bumper casting at the bottom and built into a transverse girder at the top. There are four intermediate end posts of 4-in., 8.2 lb. Z-bars, two of which are to be omitted in working to the Post Office Department Specifications. The corner posts are built up of Z-bars, placed in the same position as the intermediate posts, and two angles which are so placed as to provide a means of attachment of the outside sheathing at the side of the car and the inside end sheathing.

The side frame is made up of channel posts pressed from 1/8-in. steel. The side plate is a 4-in., 8.2-lb. Z-bar, placed with the web horizontal and the outside flange downward. The top of the belt rail is 3 ft. 1/4 in. above the lower face of the side sills. It is made up of the 4-in. by 1/2-in. strip on the outside, riveted through to a 4-in. by 2-in. by 1/4-in. angle on the inside of the sheathing. The sheathing is 1/8-in. plate, to the inside of which is applied 3/4 in. of hairfelt

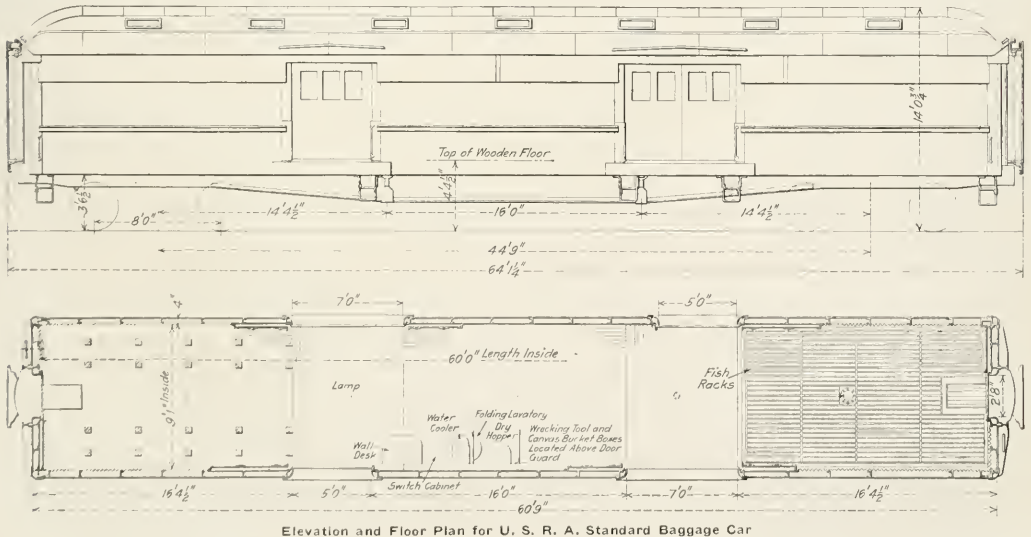

Elevation and Floor Plan for U. S. R. A. Standard Baggage Car

them. The transverse members of the double body bolster are each built up of two diaphragms of 5/16-in. plate, placed back to back. A top coverplate, 5 ft. 9 in. wide, is riveted

insulation. The interior sheathing is No. 20 corrugated steel.

The carlines are of 1/8-in. pressed channel sections. On

either side these are in one piece from the side plate to the roof of the clerestory with a separate section for the latter. The roof is covered with copper bearing steel plates insulated inside and the ceiling is of sheet steel. The underframe structure is covered with 1/16-in. steel plate, which is riveted to the center sill coverplate, the side sills and transverse supports flanged from 1/4-in. plate. On this is laid five 3-in. by 2 3/8-in. intermediate longitudinal stringers with specially gaged stringers over the top flanges of the side sills. Between these stringers the steel plate is covered with a 3/4-in. layer of hairfelt, held in place by 1-in. by 1-in. wood strips placed against the stringers. On the stringers is laid a transverse floor of 13/16-in. by 5 1/4-in. material, finally surfaced with a maple floor of 3/4-in. by 3 3/4-in. tongued and grooved material, placed longitudinally except between the doors, where it is placed transversely.

The general arrangement of the 60-ft. and 70-ft. cars is similar. The 60-ft. car is carried on four-wheel trucks, while the 70-ft. car has six-wheel trucks. The trucks may be either of the built-up pattern or the cast steel frame type. In either case the general arrangement is the same, being of the equalized pedestal type. The wheels are 36 in. in diameter and are mounted on axles with 5-in. by 9-in. journals. The six-wheel trucks have a wheel base of 11 ft. and the wheel base of the four-wheel truck is 8 ft. Both cars have two doors on each side, one having an opening of five feet and the other of seven feet. The side door on one side is placed opposite the narrow door on the other side of the car. In one end of the car a fish rack is placed over the floor, which is fitted with drainage facilities.

The 70-ft. cars are 70 ft., 9 in. long over the end posts and have a clear length inside of 70 ft. The uncoupled length over the diaphragms is 74 ft. 1 1/4 in. They are 9 ft. 1 in. wide inside and have a maximum width of 10 ft. 7/8 in. over the eaves. The maximum height from the top of the rail to the top of the roof is 14 ft. 13/16 in. The 60-ft. cars are 60 ft. 9 in. long over the end posts; they have an inside clear length of 60 ft. and a length uncoupled, over the diaphragm faces, of 64 ft. 1 1/4 in. The height and width clearances are the same in both cases.

COACH CLEANERS' WAGES

The director general has issued an addendum to Supplement 4 to General Order 27, providing the following rates of pay and rules for coach cleaners:

ARTICLE I—RATES OF PAY

(a) For coach cleaners who were on January 1, 1918, prior to the application of General Order 27, receiving less than 16 cents per hour, establish a basic minimum rate of 16 cents per hour, and to this basic minimum rate and all hourly rates of 16 cents and above, add 12 cents per hour, establishing a minimum rate of 28 cents per hour, provided that the maximum shall not exceed 40 cents per hour.

(b) All coach cleaners shall be paid on the hourly basis.

ARTICLE II—PRESERVATION OF RATES

(a) The minimum rates and all rates in excess thereof, as herein established, and higher rates which have been authorized since January 1, 1918, except by General Order 27, shall be preserved.

(b) Coach cleaners temporarily or permanently assigned to higher rated positions shall receive the higher rates while occupying such positions; coach cleaners temporarily assigned to lower rated positions shall not have their rates reduced.

ARTICLE III—HOURS OF SERVICE

Eight consecutive hours, exclusive of the meal period, shall constitute a day's work.

ARTICLE IV—OVERTIME

(a) Where there is no existing agreement or practice more favorable to the employees, overtime will be computed for the ninth and tenth hour of continuous service, pro rata on the actual minute basis, and thereafter at the rate of time and one-half time. Even hours will be paid for at the end of each day period; fractions thereof will be carried forward.

(b) Coach cleaners will not be required to suspend work during regular hours to absorb overtime.

ARTICLE V—APPLICATION

The rates of pay and rules herein established shall be incorporated into existing agreements on the several railroads.

A CORRECTION

In the article on The Design of Offset Beams, published in the September issue on page 514, several typographical errors were made in the closing paragraphs under Fig. 9 on page 516. These have been corrected and are reprinted here as follows:

Substituting the required value of 20,000 for τ and x_4 for 1, we have,

$$20,000 = \frac{45,000 \times 9}{2 \times 5 \times x_4^2}$$

$$\text{or } x_4 = \sqrt{\frac{45,000 \times 9}{2 \times 5 \times 20,000}}$$

$$x_4 = 1.42 \text{ or } 1 \frac{7}{16} \text{ in.}$$

Similarly

$$x_6 = \sqrt{\frac{31,800 \times 9}{2 \times 5 \times 20,000}} = 1.2 \text{ or } 1 \frac{3}{16} \text{ in.}$$

$$x_8 = \sqrt{\frac{63,000 \times 9}{2 \times 5 \times 20,000}} = 1.68 \text{ or } 1 \frac{11}{16} \text{ in.}$$

The shape of the section with these required dimensions is shown in Fig. 8b.

It is necessary to ascertain the angular deflection of the vertical portion of the beam, (m-n in Fig. 9) in order to determine whether the beams will be unduly distorted under the action of the maximum stresses. To find the angular deflection, use the formula

$$\phi = \frac{205 M_t l (a^2 + b^2)}{a^3 l^3 G}$$

Where

ϕ = angle of deflection in degrees.

M_t = twisting moment, in inch-pounds.

l = length of section subjected to twisting moment, in inches.

G = modulus of elasticity for shear, generally taken as 10,500,000 for wrought iron.

$$\phi = \frac{205 \times 5,300 \times 12 \times 2 \times (1.68^2 + 5^2)}{1.68^3 \times 5^3 \times 10,500,000} = \frac{7,260,000,000}{6,210,000,000} = .1165 \text{ deg.}$$

Evidently this slight angular deflection will be of no consequence, and the beam as designed has ample stiffness.

A PIECE OF FREIGHT 13,000 FEET LONG.—Ocean vessels taking oil from the Tampico fields, Mexico, must be loaded some distance out from the shore on account of the shallow water and the lack of harbor facilities; and the oil is conveyed from the shore through pipes laid on the bottom of the ocean. At Agua Dulce, about 70 miles south of Tampico, two such pipes have just been laid by the Texas Company, and each pipe is 2 1/2 miles long. Each was drawn from the shore to its position for use by a tug, assisted by a steamship, the sections having been put together on the shore and loaded on a series of four-wheel trucks, running on rails. This pipe is 8 in. in diameter and each of the two lines weighs about 382,000 lb., or as much as one of the large modern freight locomotives. These pipes are more than twice as long as any of those heretofore in use. At the outer end of these pipe lines connection is made to the tank in the ship by means of flexible metal hose.

DRAFT GEARS SHOULD BE MAINTAINED*

Proper Protection to the Car and to the Lading Requires a System of Periodical Inspection and Repairs

BY L. T. CANFIELD

IN presenting this subject I will not refer to any kind or type of draft gear, but will try to point out the necessity of keeping the device in condition to do its maximum amount of work at all times. It is understood that the duty of the draft gear is to protect the car and its contents from damage due to shocks received in the handling of the equipment. We will treat the question of capacity of draft gears in foot pounds as developed by the 15,000 lb. pendulum hammer. There are draft gears in service ranging in capacities from 5,000 to 45,000 ft. lb. Table I shows the foot pounds of energy developed by cars of different weights moving at different speeds, ranging from 1 to 10 m. p. h. These tables are made to show 60,000, 80,000 and 100,000 lb. capacity cars, both empty and loaded.

No matter with what make, type or capacity of draft gear

gear used was of the spring type, the cushioning value being two M. C. B. class G springs having a combined capacity of 60,000 lb. By referring to the diagram you will note that it required a six-inch fall of the hammer to close the springs, at which time the pressure on the sills was approximately 60,000 lb. In one instance it went up to 72,000 lb. or an average of 12,000 lb. for each one inch fall of the 15,000 lb. hammer.

Selecting test No. 4 for comparison, it will be noted that at the 14-in. fall of the hammer, the maximum strength without over-straining the sills was reached, showing a pressure of 1,025,000 lb. Subtracting the 72,000 lb. pressure developed at the six-inch fall while the draft gear was working there remains 953,000 lb. pressure that was developed on the sills between the 6-in. and 14-in. falls, which

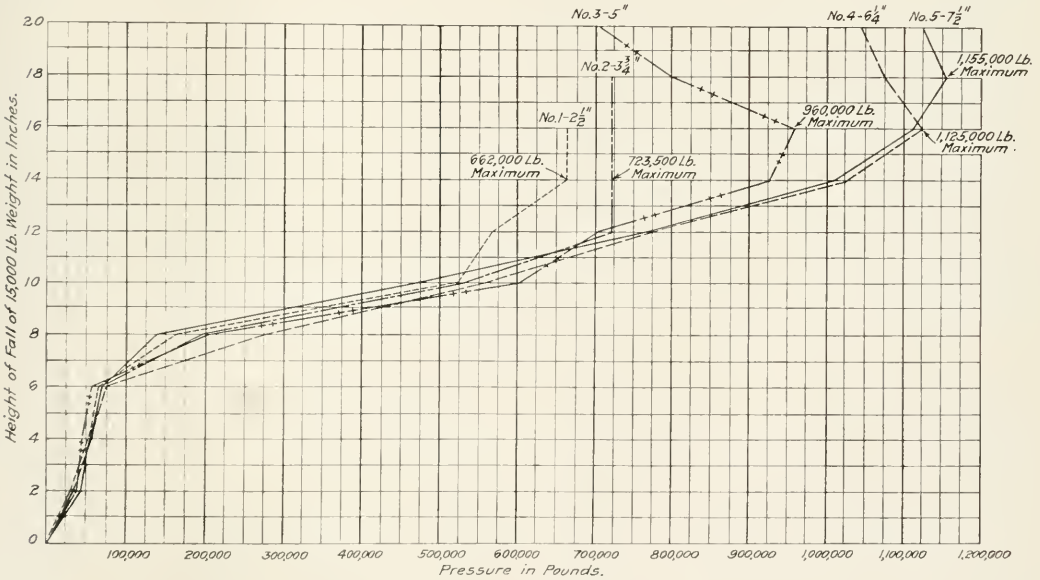

Fig. 1—Diagram Showing Strength Values of Sills Obtained by Varying the Location of the Center Line of Draft.

cars are equipped, the gear should at all times be working as nearly to 100 per cent as possible if damage to cars and lading is to be avoided. The effects of shocks on cars are illustrated by the diagram, Fig. 1, presented herewith showing the results of a series of tests made in the Union Draft Gear Company's laboratory by Professor Endsley, assisted by Mr. Barnard, mechanical engineer of that company. These tests were made to show the loss in the strength value of the draft sills by moving the center line of draft below or above the center of the channels. This diagram is shown in order to compare the difference in pressures on the sills before and after the draft gear is driven solid or closed.

In all of the five tests shown on this diagram, the draft

represents an increase of 8 in. over the fall required to close the draft springs. Dividing this by eight, in order to get the pressure for each inch of drop, the result is 119,125 lb. for each one-inch fall of the hammer after the draft gear is closed, which is approximately ten times the average pressure on the sill while the draft gear is doing its work. Therefore, if this spring draft gear was not properly maintained or its capacity allowed to decrease to the extent of a loss of one-inch drop, making it close at five inches, the result on the car would be a loss of 12,000 lb. in draft gear capacity and the imposing upon the car of 119,125 lb. additional stress.

Most modern draft gears have capacities ranging from 15,000 to 30,000 ft. lb. when tested by the pendulum hammer

*From a paper presented before the Car Foreman's Association of Chicago.

which is probably the best method of testing when attempting to show the effect on the cars. However, there are draft gears in service that will work up to a 38 in. drop of the 15,000 lb. hammer developing a capacity of 47,500 ft. lb. under which condition the pressure on the draft sills would be less than 300,000 lb.

We are told by men who make a study and test a great many couplers, that the new M. C. B. type D coupler will fail at a pressure of approximately 900,000. This failure would be represented by a shortening of the coupler equal to one inch in its length. The older type of couplers will develop the same failures at 600,000 lb. pressure. By reference to the diagram, Fig. 1, it will be noted that over 1,000,000 lb. pressure is developed on the sills between the 6-in. and 16-in. drops, therefore, a draft gear that will not be closed or driven solid with a 16-in. fall of the 15,000 lb. hammer is not only saving the draft sills but the couplers as well.

With the explanation of the difference in pressures on the cars when the draft gear is working and after it has been closed, showing that if the draft gear is not working the effect of the shock on the car can be multiplied by ten, I think we should begin to look into the best method of maintaining the draft gears.

The first point is that in repairing a draft gear, the repairs should be made in such a manner that it will retain its full travel. I know that I myself have repaired cars by applying solid followers in order to take up the slack, thinking that by removing the slack I was doing good work. To prove that this is wrong I would call your attention to the diagram shown in Fig. 2, which represents a 60,000 lb. capacity draft gear with 1 3/4-in. travel. The whole area of the triangle is the maximum amount of work possible with this type of a gear and would be represented by a 6-in. drop.

Should this gear become slack making it necessary to apply a follower 1/2 in. thick to compensate for the set in the draft springs, there would be a reduction in the working capacity of the draft gear as shown by the shaded portion of the diagram which is a loss of nearly one-half of its efficiency. As explained above, as long as the draft gear is working the pressure on the car amounts to 12,000 lb. for each one-inch

tained to their designed travel and any part of their mechanism that shows that it has suffered a loss in its working value should be discarded and a new part substituted.

In order properly to maintain the draft gears they should be treated in the same manner as the air brakes, for instance a safe working life should be agreed upon and to start with the name and type of the draft gear, the date it was applied and its working travel should be stenciled on the draft sill. I am not prepared to say what is the safe working life of the

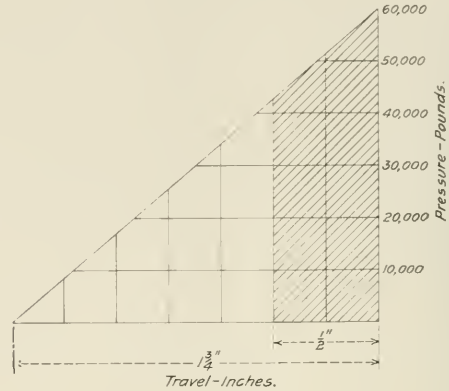

Fig. 2

different makes of draft gears, but assuming three years, I think a positive rule should be put into effect that at the expiration of the three years the draft gear should be removed from the car, inspected and repaired and made as good as when new. This rule should act the same as the rule for maintaining air brakes. In case a car is found where the draft gear has run beyond its allotted time without being removed, the repairs should be compulsory on the road having the car in its possession and the owner of the car should be responsible for the cost of such repairs.

TABLE I—ENERGY IN MOVING CARS AT VARIOUS SPEEDS

Velocity		Weight of car..... 33,000 lb. Weight of load..... 60,000 lb. 10 per cent excess... 6,000 lb.		Weight of car..... 39,000 lb. Weight of load..... 80,000 lb. 10 per cent excess... 8,000 lb.		Weight of car..... 45,000 lb. Weight of load..... 100,000 lb. 10 per cent excess... 10,000 lb.	
		Total load..... 99,000 lb. Energy in foot pounds		Total load..... 127,000 lb. Energy in foot pounds		Total load..... 155,000 lb. Energy in foot pounds	
M. P. H.	F. P. S.	Light	Loaded	Light	Loaded	Light	Loaded
1.	1.466	1,102	3,306	1,303	4,244	1,504	5,179
1.5	2.2	2,481	7,443	2,932	9,548	3,383	11,660
2.	2.933	4,414	13,240	5,216	16,980	6,018	20,730
2.5	3.666	6,895	20,680	8,149	26,540	9,402	32,380
3.	4.4	9,924	29,800	11,740	38,220	13,500	46,650
3.5	5.133	13,514	40,540	15,970	52,000	18,420	63,490
4.	5.866	17,654	52,960	20,860	67,940	24,070	82,920
4.5	6.6	22,350	67,050	26,410	86,010	30,480	105,000
5.	7.333	27,590	82,770	32,600	106,140	37,620	129,600
5.5	8.066	33,380	100,140	39,450	128,500	45,520	156,800
6.	8.8	39,730	119,190	46,950	152,900	54,180	186,600
6.5	9.533	46,620	139,860	55,090	179,400	63,580	219,000
7.	10,266	54,120	162,360	63,860	208,000	73,700	253,800
7.5	11.	62,080	186,240	73,260	238,900	84,650	291,600
8.	11,733	70,630	211,890	83,470	271,800	96,310	331,700
8.5	12,466	79,710	239,130	94,250	306,900	108,700	374,600
9.	13.	89,390	268,170	105,600	344,000	121,900	419,900
9.5	13,933	99,600	298,800	117,700	383,400	135,800	467,800
10.	14,666	110,200	330,600	133,500	424,400	150,400	517,900

fall of the hammer; therefore, should we lose by the introduction of the slack follower, the working value of the draft gear equal to one or more inches drop, we add to the stresses on the car 119,125 lb. for each one-inch loss in draft gear work. Hence, it is bad practice to attempt to use draft springs that have taken a permanent set or do not measure up to their full travel. It would be economical to put these in the scrap pile and save the damage to the couplers or other parts of the car that fail. Draft gears should be main-

When you have put into effect this or a similar rule, the cost of maintaining equipment and the loss due to damaged lading is going to be materially reduced, as you can readily see the advantage of maintaining a device that will only register one-tenth the force on the car when it is working compared to the amount registered after it has been closed. Some may believe that this will create an extra amount of work on the cars, but when they see the large number of couplers that fail, ends pushed out by lading, superstructures

racked, roofs loose, draft sills, end sills and in fact all parts of the car destroyed in performing the work of the draft gear, it appears the great waste of labor and materials is in not keeping the draft gear as near to full efficiency as possible at all times.

I would strongly recommend the building up of a force of draft gear men who would be experts just the same as you were forced to build up a force of expert air brake men in order to get the benefit of the air brakes. These men should avail themselves of laboratory investigations and talks with men who have made a study of draft gear just the same as the air brake men had to do when they started out. The draft gear is of even more importance than the air brake to the safe and economical handling of car equipment.

DISCUSSION

In the discussion emphasis was laid on the fact that after the safe speed for switching cars is passed a very slight increase in the velocity increases the energy stored in the car greatly and multiplies the damage to equipment. The necessity for maintaining the maximum travel of draft gears, especially on heavy equipment, was brought out. If the draft gears had higher capacity there would be fewer bad order cars, as shocks damage not only the draft gear and rigging, but the entire car. The speakers expressed the opinion that from 80 to 90 per cent of the bad order cars were due to poor draft gear and draft rigging.

THE JOURNAL BOX PACKING SITUATION

Among the materials used on the railroads which are becoming scarce due to the war, none is more important than journal box packing. The requirements for all the roads of this country are estimated at about 20,000,000 lb. per year. At the present time the best of the wool wastes formerly used for packing are being reworked into yarn and used for blankets, etc.

In order to secure the necessary amount of packing it will probably be necessary to use substitute materials. In the past the principal stocks used for journal box packing have been woolen and cotton waste. In some cases other materials were added but these formed the basis of all the mixtures.

As the function of the waste used in packing is to carry oil to the journal, the first requirement in material used for this purpose is the ability to raise oil by capillary action. The waste should be resilient when soaked with oil so that it will keep in contact with the journal. Furthermore, it should not disintegrate under the action of the oil and should be of such a nature that it can be cleaned and reused. Wool waste has more resilience than cotton but cotton absorbs and carries the oil by capillary action better than wool. Inasmuch as resilience is absolutely necessary to get good results, wool waste has been used almost exclusively for passenger car and locomotive service and for most freight car service, though, of course, the mixtures contained some cotton.

Before discussing the possible means of overcoming the shortage of woolen waste it may be of interest to enumerate the materials entering into the various mixtures used for journal box packing.

DESCRIPTION OF MATERIALS

Axminster and Brussels Carpet Yarn.—This is composed of the clippings and ends from the carpet looms and is the highest grade of wool yarn. This material is getting very scarce as the better grades are being reclaimed and respun. The price is now nearly four times what it was three years ago. It is undoubtedly the finest material for packing waste but its price prohibits the use of it in large quantities. It can be reclaimed practically as good as new.

Shredded Wool Carpet.—Shredded wool carpet is not as good as new wool yarn as the fibre is shorter but it is good material if properly combined with other longer fibred materials. In shredding it, a small amount of oil is usually used in order to get the best results. Shredding should be done so as to produce the minimum of short broken threads and any pieces of unshredded carpet should be picked out. An excess of oil is sometimes found in this stock.

Shredded Linsey.—This is a very poor grade of material secured by shredding Linsey carpets. It is dirty, short fibred and practically all cotton. It is undesirable for packing waste and should only be used if nothing else is available. It yields practically nothing in reclamation.

Domestic Merino.—This material is the waste product of the hosiery and clothing mills. Its wool content varies from 40 to 80 per cent. It should be well twisted, long, clean and resilient. Different lots vary greatly in the length of fibre and general quality. It is very good material for incorporation in journal box packing. It comes mainly from New England and the supply is beginning to fall short of the demand. In former years large amounts were imported from England. At the present time this source of supply is not available. A low grade is imported from Japan.

Muck Yarn Waste.—The term "muck yarn" is generally used to cover all the respun yarns though the higher grades are sometimes called "respun" yarns. Its wool content varies from almost nothing to about 75 per cent. It is made from sweepings, fly, cow hair and various other materials, and is sometimes dyed bright colors to make it look like carpet yarn. It is very short fibred and breaks up very easily. The mixing machine breaks it up to a certain extent and when it is in packing service it goes to pieces rapidly, and as a result causes what are known as "wiper" hot boxes. Its use in packing waste is very undesirable. Its cost is rising as it is being used in the manufacture of cheap blankets, etc.

Cocoon Fibre.—This fibre is shipped from the Philippines, India and Central America. Before being used it must be machined. In this machining a certain amount of oil is usually added. It will not carry oil to the journal but it does soak up a little oil and after considerable service it often breaks up. The resulting small particles are undesirable in the journal box. It will burn in case the journal gets very hot. The greatest difficulty in connection with its use lies in the fact that it is a difficult matter to incorporate it properly in a mixture of waste. Packing containing cocoon fibre should be run through the mixing machine at least twice to get it properly mixed. If there are balls of it separate from the wool, trouble will be experienced with the journal box in which it is used. It is also troublesome when waste is reclaimed in the centrifugal machine. The purpose of incorporating it in waste is to give resilience. While cotton is the best oil carrier, it is not resilient and now that the high grade wool yarns are so scarce, the fibre is used to give this resilience which the cotton content lacks.

Tampico.—A coarse vegetable fibre used for making brushes and cheap ropes. It is used in some mixtures to increase the resiliency.

Jute.—The fibre obtained by maceration from the inner bark of the jute plant, used in the manufacture of gunny sacks and ropes. Its use in packing should not be permitted.

Moss.—This moss comes from Florida. It is retted to remove the hard portions. It will not absorb oil. It is considered by some to be superior to the cocoon fibre, but it is open to practically all the objections which have been raised to the latter.

Asbestos.—This is sometimes used in packing mixtures. It is of no advantage and merely adds to the weight.

White Spooler.—The most common ingredient of good white waste. It is soft but often short fibred.

Shredded New Colored Rags.—This material is often prohibited in specifications for colored waste, but under present conditions such restrictions result in much higher cost. The per cent should, of course, be kept down and the grade held up. Some of this shredded rag stock is fine, soft material. Shredded old rags is a rather poor stock as the old rags are often partially rotted. All cotton stock for journal packing should be free from hard, sized threads.

White Cop.—This is the finest of all cotton waste stock and the amount available is limited. Certain amounts of it are put in the higher grade cotton waste mixtures.

White Waste Machined.—Only small amounts of white waste are used, as colored waste answers the purpose and is easier to get. A high grade colored waste costs as much as white waste. The finest white waste is the "cop" which is scarce and only small amounts of it are usually incorporated in the mixture. The sized slashed threads are undesirable as they are hard and coarse.

MIXTURES USED FOR PACKING

A good grade of wool waste stock for car packing contains about 75 per cent of shredded wool carpet and 25 per cent of domestic merino. This is suitable for use in either passenger or freight cars. It can be secured at a reasonable price. Other typical mixtures now in use are made up of about 50 per cent wool carpet and merino, 35 per cent cotton and 15 per cent vegetable fibre. The maximum permissible proportion of threads shorter than three inches is usually limited to from 25 to 40 per cent. The moisture content is limited to about 8 per cent. The constituents are run through a mixing machine one or more times to get them evenly distributed in the packing and also to improve its resiliency.

It may prove necessary to use packing containing smaller proportions of wool than in the mixtures given above. The supply of cotton stock is ample, although the price is high, and this will probably come into more general use. The principal objection to cotton packing is that it lacks resiliency and, therefore, does not remain in contact with the journal, though it is theoretically the proper material for carrying oil since its capillary properties are nearly twice those of wool. Numerous methods of securing the necessary resiliency with cotton packing have been tried. Steel wool, coconut fibre and moss are sometimes mixed with the packing to give resiliency, but all of these are open to numerous objections, such as breaking to pieces, matting, preventing reclamation, etc., and some of the roads which have tried them have had to abandon them.

RECLAMATION OF PACKING

As the supply of raw materials for use in packing is constantly decreasing, every effort should be made to reclaim it. All roads should install proper plants for the reclamation of both wool and cotton waste. Roads that have provided such facilities should see that all available material is sent to the reclamation plants. The cost of reclaiming wool waste is more than made up by the value of the babbitt reclaimed and the oil secured is a large item. The methods of reclaiming packing in general use are described below:

Method No. 1.—The dirty packing is shipped to the reclaiming plants in barrels. At these plants it is first heated in a large vat surrounded by steam coils. It is then placed in a centrifugal wringing machine, similar to those used in laundries. It is revolved in this machine for a period of about five minutes; during this process the oil is thrown out of the packing and a considerable amount of the dirt passes out with it. Still more of the dirt and the heavy particles of babbitt settle in the bottom of the machine. The packing is then removed from the machine and picked over by hand. Inasmuch as the packing is practically dry, the dirt separates from the wool very easily, leaving a clean material without

the dirt or short fibre. This packing is then put in the mixing vat and used similar to new packing. The oil which is removed in the centrifugal machine is passed through a series of four fine screens and a bed of curled hair or charcoal. The reclaimed oil is perfectly satisfactory for use the same as new oil. The babbitt is melted down and skimmed and babbitt blocks made for issuance as new babbitt.

Method No. 2.—The packing is taken directly from the barrels and placed in a large vat of oil which is heated by means of steam pipes. It is forked and stirred around in order to wash the dirt from the packing with the oil. When it is sufficiently well cleaned it is put into a second vat where it is mixed ready for service. The vats are cleaned out and the material from the bottom is put in an air driven press and the oil squeezed out. This oil is cleaned by means of a centrifugal machine and the oil is used over.

METHODS OF RECLAIMING COTTON WIPING WASTE

The dirty waste should be shipped to a central plant which is fully equipped for this work. The waste should first be washed either with gasoline or lye and soda ash. It should then be wrung in a centrifugal wringer and dried in a specially constructed oven or, if this is not available, on steam coils. It will be found necessary to have special tanks prepared for the first washing. In case the lye and soda ash method is used, special skimming devices are necessary to remove the dirt and grease which comes to the surface. Care must be used in the handling of waste from the paint shop to avoid danger of fire from spontaneous combustion.

In the past, few roads have paid enough attention to journal box packing to insure that it was handled properly. The present conditions demand that this policy be changed in order to avoid a serious shortage of such material. The term "waste" should be confined to stock used for wiping. The mixtures used for packing boxes should be referred to as "journal box packing." The improper use of the term "waste" is largely responsible for the lack of care in handling this material, which is generally regarded as a waste product. All roads should issue definite instructions to the mechanical department employees as to the methods of packing journal boxes and reclaiming packing.

MAINTENANCE OF AIR BRAKES

The regional directors are now giving special attention to the proper maintenance of air brakes and are addressing letters to their federal and general managers as follows:

The proper maintenance of air brakes on all classes of equipment is an important matter from many points of view and is a subject that is not given the careful attention it should be given. In addition to the impossibility of properly handling and controlling trains with poorly maintained brakes and leaky pipes, hose and other apparatus, fuel losses from these causes are startling. It is estimated that there is a waste of more than 6,000,000 tons of coal annually due to train pipe and other air leakage. The shortage of coal makes it necessary now, more than ever before, to bring about greater efficiency. The proper maintenance of air brake equipment will not only contribute to a large extent in fuel saving, but will also reduce maintenance costs and improve your train operation.

The following should be rigidly enforced:

Ample time allowed for inspection of air brakes.

All leaks and defects properly repaired.

Air brakes should be thoroughly gone over, cleaned and tested on all cars on shop or repair tracks and all leaks eliminated.

Train pipes, cylinders and all parts should be securely clamped. This is a matter that is given little attention.

Careful inspection of hose should be made to detect porous hose and to see that hose fittings are securely clamped. Poorly clamped fittings often result in hose being blown off, resulting in wrecks or serious damage to equipment.

Whenever possible train yards and shop tracks should be equipped with yard testing plants to enable inspectors to test cars and trains standing in the yards and make repairs often

before trains are made up, resulting in reducing of terminal delays and overtime.

The leakage on outbound trains after a service reduction of 15 lb. has been made and valve placed on lap, should not exceed 8 lb. per minute. If leakage exceeds that amount the trouble should be corrected.

M. C. B. Rules covering the inspection and maintenance of air brakes should be rigidly enforced.

HEAVY FREIGHT CARS FOR A NARROW GAGE RAILWAY IN INDIA

BY FREDERICK C. COLEMAN

By far the most interesting of all the mountain railways in India, or perhaps in the Far East, is the 2 ft. 6 in. gage line connecting Simla, the summer capital of India and the Punjab and the headquarters of the Indian Army all the

footed steel rails, with spikes and bearing plates on wooden deodar ties, but more than half of these have now been replaced on renewal by 60 lb. rails. The line is ballasted with stone, and it is fenced only along the Kalka camping ground and through the outskirts of the town of Kalka.

Most of the curves are compound, the limiting radius being 120 ft. and the ruling grade is 3 per cent. not compensated for curvature. Upon leaving the Kalka junction, where the broad-gage trains stop, the line almost immediately commences to ascend the spurs of the mountains, taking turns continuously until Simla is reached. The spurs are generally of a favorable character and they are taken advantage of when they lie in the right direction, but, where they do not, tunneling has been resorted to. The ridges are connected by "saddles" of varying heights, not always progressive in favor of the ascent, so that the line, having surmounted a ridge, has



Narrow Gage Gondola Car of the Sheffield-Twinberrow Type for the Kalka-Simla Railway, India

year round, with Kalka, and there forming a connection with the East Indian Railway system.

Simla, situated among the foot-hills of the Himalayas at an altitude of 7,116 ft., relied, until November, 1903, upon "tongas," or country carts, for its communication with the outer world. The railway was commenced in 1899 and

sometimes to descend. However, as the mountains rise, so do the majority of the "saddles." In spanning mountain gorges and ravines, girder viaducts are not usually employed, but masonry structures called "galleries." These resemble Roman aqueducts, and they consist of tiers of arches rising one above the other until the rail level is reached. They are



Box Car with Sheffield-Twinberrow Underframe and Trucks for the Kalka-Simla Railway

opened for traffic in 1903, and since January 1, 1907, it has generally on a curve, and the curvature is formed by making been worked by the Indian North Western State Railway the piers wedge-shaped. The retaining walls are made of dry administration. It has a total length of 60 miles of singlestone, hand set, of 10 ft. to 15 ft. in width, and bands of track throughout. The permanent way consists of 41 lb. flat-masonry 2 feet wide are introduced at intervals of about

5 feet, according to circumstances. There are no fewer than 21 stations, and the railway carries about 150,000 passengers and 62,000 tons of goods each year.

In order to provide facilities for the increasing traffic, additional locomotives of a more powerful type have recently been introduced, the passenger vehicles have been re-designed, and all-steel coaches have largely been adopted.

Simultaneously, a considerable number of all-steel high-capacity freight cars, both open and covered, have been imported from England. Among these are 50 cars of the Sheffield-Twinberrow pattern, built by the Leeds Forge Company, Limited, of Leeds, England, from the designs of George H. Sheffield, of Victoria street, Westminster. They are of two standard types, open and covered, of 42,560 lb. and 39,200 lb. rated capacity, respectively.

The following is a table of the leading dimensions of the open cars:

Length inside and over end sills.....	30 ft.
Length over buffers and couplers.....	33 ft.
Height inside.....	3 ft. 6 in.
Width inside.....	7 ft.
Width overall.....	7 ft. 5/4 in.
Centers of trucks.....	20 ft.
Wheelbase of trucks.....	14 ft. 3 in.
Diameter of wheels on tread.....	30 ft. 8 in.
Size of journals.....	7 in. by 3 1/4 in.
Centers of journals.....	3 ft. 9 1/2 in.
Tare weight complete, including vacuum brake equipment.....	14,000 lb.

The over all dimensions, with the exception of the height, are similar in both types of cars and, with the single exception of pressed steel end sills and end longitudinals, only three standard British steel sections are employed in the structures. Cast steel wheels are employed, and these were pressed on the axles under a pressure of 40 tons, the bosses of the wheels

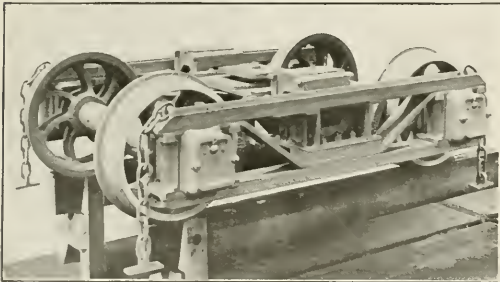

Truck of the Sheffield-Twinberrow Type Used Under Some of the Kalka-Simla Freight Cars

being keyed to the axle seats. The journal boxes are also of cast steel and are fitted with loose key plates and are designed to permit of oil lubrication, either by means of adjustable pads or waste packing. The tare weight of the covered car is 15,350 lb. A number of the covered cars are fitted with water tanks, each of 115 cu. ft. capacity. The weight of the empty tanks and fittings is 1,456 lb. The trucks, underframes and general dimensions of the covered cars are identical with the open cars, but an additional standard British section is employed for the longitudinals and the transverse bracing of the plates and of the roof.

One of the photographs shows the Sheffield-Twinberrow patent truck. The salient feature of this design of truck is that the weight of the car is not carried on the centre, but is distributed through groups of coil springs at a transverse distance of about 16 in. from each side of the centre. The bending moments upon the main transoms are thus considerably reduced, and the effect is to add materially to the reduction in weight of the structure. The springs are compounded to act efficiently when the car is either loaded or empty. They rest in cast steel boxes, the lower parts of which are at-

tached to and between the bogie transoms or bolsters. The upper, or loose, portions of the boxes are provided with large rubbing surfaces, which have a sliding contact, with corresponding rubbing pieces upon the car main transoms. Although tilting action alone is allowed for the extent of the clearance between the center pins and pivot casting, and the spring boxes and the side checks on the bolster frames of the trucks, there is ample provision for lateral and end movement to suit inequalities in the rails or super-elevation.

A distinct advantage in dispensing with the customary swing bolster is the fact that there is no vertical movement of the brake shoes, whether the car be empty or loaded. A uniform wear of the brake shoes is thus ensured and there is the same range of brake levers under either empty or loaded conditions. The weight of these trucks, complete, is 2,556 lb. Some of the covered cars are provided with an additional pair of doors at the top in the centre, as shown in one of the illustrations, and the tare weight of the cars is increased to 15,340 lb.

Several of the open and covered cars recently supplied for use on the Kalka-Simla Railway are fitted with an arch bar truck. The general dimensions of these cars and the structural details are similar to those already described, except that the weight of the truck is 3,192 lb., which increases the tare weight of the cars to 15,120 lb. and 16,910 lb., respectively, as against 14,000 lb. and 15,340 lb., the tare weights of the open and covered cars fitted with the Sheffield-Twinberrow truck.



Courtesy of Liberty Loan Committee

Some Tree



SHOP PRACTICE



RECLAIMING TOP HEADS OF WESTINGHOUSE 9 1-2 IN. AIR COMPRESSORS

BY J. H. HAHN

Assistant Roundhouse Foreman, Norfolk & Western, Bluefield, W. Va.

Some trouble is experienced with the Westinghouse 9 1/2-in. air compressors on account of the threads in the reversing valve chamber stripping. This often makes it necessary to replace these heads. It is an expensive practice to scrap the heads on account of this defect, especially under present conditions, and the sketch shows a special chuck or jig which was designed by H. B. Stratton, a machinist in the Bluefield shops, for holding the heads while boring out the reversing valve bush chamber for the bushing used in reclaiming the heads.

The jig is forged out of wrought iron in one piece and finished all over. After it has been threaded to fit the lathe spindle, and faced off, it is advisable to finish it on the spindle of the lathe on which it is to be used. Four holes are drilled to receive 5/8-in. machined bolts which are used

the ports, always re-drill the ports with the proper size drills and test the heads after they have been assembled. The bushings should be applied reasonably tight, after which they are faced off to give the reversing valve bush chamber the proper depth. Heads repaired in this manner will give excellent service and there is reduced chance of the threads stripping.

OXY-ACETYLENE AND ELECTRIC WELDING*

BY A. F. DYER

General Foreman, Welding Department, Grand Trunk, Montreal

With the present price of material, scarcity of labor and difficulty of obtaining steel and iron, welding and cutting by both the electric and oxy-acetylene processes has proved to be a great help and an almost indispensable factor in railroad repair shops.

Seven years ago the Grand Trunk employed one man as an acetylene welder and owing to failures through his lack of experience, the process was nearly condemned, but as we gathered experience both gas and electric welding developed, so that now instead of one man we employ eighteen and often work them overtime.

The low pressure acetylene gas system is used and the whole shops are piped for the acetylene, every other repair pit having a drop connection. In roundhouses we use Prest-O-Lite dissolved acetylene in cylinders which saves the expense of a generator and piping where the process is only in use occasionally.

There are many kinds of electric welding outfits on the market. Our new equipment using alternating current instead of direct current, weighs only 150 lb., gives from 20 to 200 amperes, and is about 50 per cent cheaper than any d.c. machines. The outfit consists of two generators each operating four welding circuits. A panel control allows each man to change current independent of the other welders.

Both of these methods of welding have proved themselves fit to be ranked amongst the greatest time and labor savers introduced on the railroads for a long period. For instance, not long ago a locomotive with a broken frame would be held in the shops for several days as it would take some time for removing the frame, and having it welded in the smith shop, then machined and replaced. Now a frame 4 in. by 5 in. can be cut and welded in less than 14 hours. Frames, when worn by brake gear and stays, are built up and worn holes are plugged and welded instead of reaming them out to a larger size and thereby weakening the frame.

The present price of tool steel demands that none shall be wasted, therefore we use it down to the last inch by welding it to tire steel. Twist drills, taps and reamers when broken near the socket end are welded and put into use again. For this purpose we use either the electric or gas process, but in both cases we use vanadium steel filling rods, as we find this gives the best results. Spokes of driving wheels

*Abstract of a paper presented before the Canadian Railway Club, December 11, 1917.

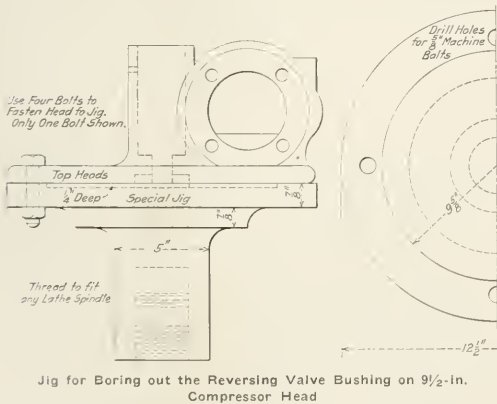

to bolt the head on the jig. Only one bolt is shown in the sketch.

By using this device it is not necessary to set up the heads. The jig is threaded to screw on to the lathe spindle and the heads bolted to the jig as shown in the sketch. As the reversing valve chamber is in the center of the head, no adjusting is required. This method shortens the operation of boring and threading the chambers to receive the bushing. The bushings used are of the usual design made of wrought iron, threaded on the outside 10 threads per inch and on the inside to receive the reversing valve chamber cap. The bushings may be made on a turret lathe in quantity and carried in stock. It is imperative that all original dimensions be maintained in making repairs to the top heads, and if necessary to apply a bushing that extends below any of

are welded and flat spots on tires have been successfully welded when it was necessary to do so.

Up to the present time we have not had much success welding cast iron with the iron electrode although with the carbon a fair job can be done, but the gas is unquestionably the best for any of this work. We have successfully welded with oxy-acetylene, steam shovel engine frames and cylinders by welding in patches of cast iron where worn or broken. When our contract for shells was completed and the lathes that were used for this purpose were being overhauled, it was found that most of the V-slide beds were worn by the tool carriers. These were built up by the oxy-acetylene process, which saved machining the beds down as much as $\frac{3}{8}$ -in. in some cases.

In regard to boiler work, most of the welding is done with the iron electrode using a mild steel or Swedish iron as a filler. It is found that the electric process localizes the heat more than the gas, though it is the writer's opinion that the gas makes a closer and neater weld, as all welds made by the electrode are more or less porous unless they are hammered. When patching a firebox it is better whenever possible to apply quarter or half side sheets in order to get the weld out of the fire. However well a patch is welded, it generally gives out in from twelve to eighteen months' service, and the same applies to cracks, whereas the quarter or half side sheets should last as long as the firebox.

When a nest of small cracks is found round the staybolts, the bolts are removed and the holes countersunk and welded. This method has been found to be very successful. Corner patches are welded by running the patch into the tube or back sheets, as the case may be, at the same time removing the flanges. If it is decided to do away with a number of tubes, plugs are welded in the holes. The holes are countersunk and the plugs are punched by a countersunk die which gives them the proper bevel for welding.

Superheater flues are being successfully welded to the tube sheet. The operators I am connected with prefer to have the flues belled and water in the boiler. This keeps the tube sheet from heating, especially around the smaller tubes. The tubes are set in with copper ferrules set back $\frac{1}{32}$ in. and the flues are belled out $\frac{3}{16}$ in. to $\frac{7}{32}$ in.; the small tubes, $\frac{3}{16}$ in. The sheet is roughened all around the tubes and flues, and the oil is then burnt off with the oxy-acetylene flame and tubes and flues welded in with electrode, using $\frac{1}{8}$ in. mild steel or Swedish iron. The latter is preferred if calking is needed.

A sample of an average day's work is as follows, for a gang of 12 men:—

- 14 rivet holes in smoke-box and 4 peg holes in foundation ring.
- 10 tube holes in upper portion of firebox tube sheet.
- 2 air pipes which were worn through.
- In the tool room:
- 1 ratchet for jack (2 teeth replaced).
- 1 gear spindle built up.
- 1 chuck screw, key end built up.
- 1 boring shaft built up from $2\frac{1}{2}$ in. to $2\frac{3}{4}$ in.
- 2 tool holders, rebuilt.
- 1 air hammer handle repaired.
- 6 teeth in lathe gear, built in.
- 1 cone, small end filled up solid.
- 2 $\frac{1}{2}$ in. holes in top rail of frame filled up.
- 4 cracks 18 in. long in right side sheet welded.
- 14 bottom tube holes welded up.
- 2 washout plug holes built up for re-tapping in round head.
- Cut out frame for welding and started welding same.
- Welded bushes in pony truck stays.
- Cut out 3 sets of boiler tubes.
- Cut out one set of superheater flues.
- Build up calking edge of first hole.
- Heated corners of tube sheet for closing.
- Welded broken superheater damper bracket.
- Build up reversing lever where worn.
- Build up 2 side rods where worn.
- Cut out 48 flexible staybolts in firebox.
- Welded 2 cracks in throat sheet.
- 1 broken flange of air brake cylinder.

In addition to this list two men are engaged continuously on cutting around the shops.

For cutting steel and wrought iron the oxy-acetylene process has practically no competitor, it being impossible with the carbon point to cut as fast or as fine and neatly as with the gas torch. For scrapping fireboxes and frames, the carbon point is cheaper to use if time is no object and labor is cheap.

The foregoing examples illustrate only a very small fraction of the uses to which the two methods of welding and cutting are being put in locomotive repair and machine shops, and fresh uses are being found for it every day. No roundhouse should be without an oxy-acetylene outfit, both for repair work and as a part of the wrecking outfit, and all large roundhouses should have both processes, as they would pay for themselves over and over again.

In concluding, I would state that though there are many different opinions as to which is the best process, no shop is complete unless it has both equipments, although the gas has really the widest range.

Welding should not be treated as a side line of the machinists' or boilermakers' business, but should be treated as a trade in itself, as it really is, for it needs the entire concentration of a man's mind, careful study, plenty of practice and a conscientious man to make a welder.

Wherever possible a separate building or suitable space should be provided for bench work, and should be equipped with a suitable furnace for heating and annealing castings. There should also be plenty of floor room for charcoal fires for preheating cast iron jobs before welding.

DISCUSSION

The extreme value of both welding processes was admitted by all, but there was a decided difference of opinion as to the detailed performance of the work. In fact, most of the discussion hinged on the relative value of lap and butt welds in firebox construction.

It was generally admitted that complete fireboxes could be welded by either the acetylene or the electric process, and A. M. Barry, of the St. Lawrence Welding Company, claimed that a safe joint could be secured only by the use of the lap weld. He claimed for the lap weld a high factor of safety, increased stiffness, double strength and added safety, due to staybolts.

The majority of railroad men, however, favored butt welds because of uniformity in metal thickness, more flexibility to prevent staybolt breakage, and less chance of defective welds due to surface scale. With either process, however, attention was called to the absolute necessity of having careful and experienced welders and the need for training such men. It was also recommended that welds be hammered as they are built up.

The possibility of increased tube mileage due to welding was discussed and generally admitted, and Mr. Barry described the application of welded boiler patches with rounded corners, again recommending the lap weld. In response to a question he stated that in his experience the welding of manganese steel was not successful.

TIME SAVED BY PAINT SPRAYING MACHINES

Some interesting figures as to the time required to paint steel hopper cars by the spraying method were obtained from the Carolina, Clinchfield & Ohio at Erwin, Tenn. By the use of paint spraying machines two men have been able to paint and stencil 24 cars in 10 hours. Under the conditions prevailing during the early part of the present calendar year, the cost of labor for painting, stenciling and light weighing the car was approximately 55 cents. The total cost for labor and material for painting one car complete was about five dollars.

MACHINING LOCOMOTIVE DRIVING BOXES

An Interesting Outline of the Work as Performed at the Sacramento, Cal., Shops of the Southern Pacific

BY FRANK A. STANLEY

WHILE the work of machining locomotive driving boxes is a common operation in every shop, the methods followed by the Southern Pacific, in its Sacramento, California, shops is particularly interesting on account of the machine tools used in the work. The various

are well illustrated by this view. The driving box is a steel casting and is machined to receive a brass shell $2\frac{1}{2}$ in. thick. The face of the box is machined for a babbit lining which when finished is $3\frac{1}{8}$ in. thick.

The method of holding the boxes on the shaper in Fig. 1 is shown sufficiently clear in the illustration. The type of machine used here lends itself admirably to this class of work. Its ram reaching forward through the casting and cutting on the return stroke permits of a heavy feed and deep cuts without chatter and the springing of the tool away from the surface of the work. As shown here, the cutting tool is removing the metal with a depth of cut of about $\frac{1}{2}$ in. and a feed of $3\frac{3}{32}$ to $\frac{1}{8}$ in. per stroke of ram, which means a very reasonable length of time for completing the semi-circular seat for the brass. Running say at 15 complete forward and return strokes per minute, the actual rate

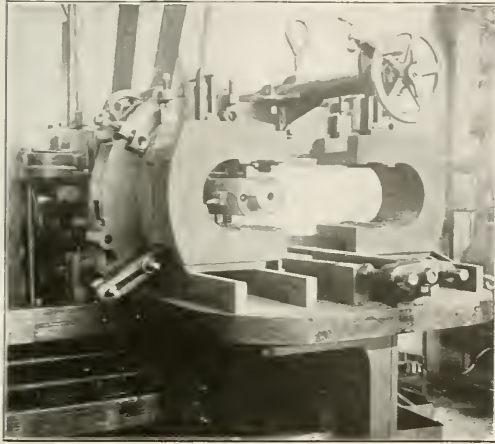

Fig. 1—Planing Driving Boxes on a Draw Cut Shaper

steps in the performance of the work are well shown in the illustrations. Fig. 1 shows a pair of 9 in. by 12 in. driving boxes set up in the chuck on a Morton draw cut shaper

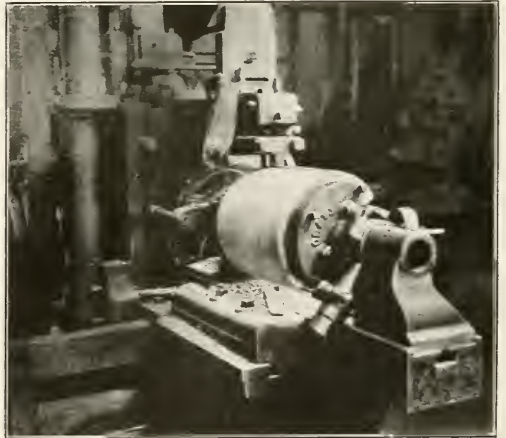

Fig. 3—Planing the Brass

of operation under a 3 to 1 ratio for the noncutting stroke would work out at 25 feet per minute.

PLANING THE BRASSES

The methods followed in shaping the outside of the brasses on the same type of machine is illustrated by Figs. 2 and 3. Here the work is shown mounted between fixtures on a rotary clutch which turns automatically, the amount of the desired feed upon the completion of each stroke of the shaper ram. Fig. 2 shows the convenient method of picking up the work with the sling and hoist to place it in the fixture and the other photograph represents the planing operation nearing completion. The shaper is operated at the rate of 20 complete strokes a minute with a feed of $3\frac{1}{16}$ in. and a depth of cut ranging from $\frac{1}{4}$ to $3\frac{1}{8}$ in. So the finishing of the external surface requires only a few moments and the setting and removal of the work causes but a brief delay between successive brasses.

A homemade press is used for forcing the brasses into their boxes. This press stands near the boring and facing

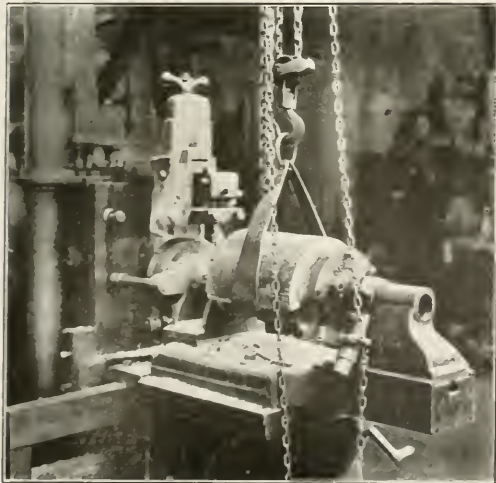

Fig. 2—Setting Brass in Draw Cut Shaper Fixture

where the interior of the jaws are planed out and the circular seat planed to receive the brass. The proportions of the work

machine and is also adjacent to the planers where the sides and end of the boxes are surfaced.

PLANING BOXES

The sides of the boxes are planed as in Fig. 4 with two rows of boxes secured to a long fixture on the planer platen so that the entire length of the table is filled with the boxes permitting the use of both tool heads. The fixture is in the form of a long cored casting with outer faces adapted to receive the boxes which are bolted against its opposite faces by the long through bolts, straps and nuts as shown. The work is further secured by straps spanning the gap between

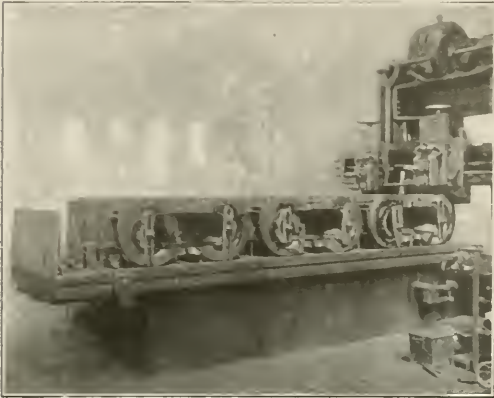

Fig. 4—Planing a Lot of Boxes at one Setting

each pair of boxes and drawing the work firmly down to the platen surface.

The top of the boxes are finished on the draw cut shaper as shown in Fig. 5 where a single box is set up, as indicated, against an upright surface on the side of the table. The method of strapping and clamping here is well indicated in the photograph.

BORING AND FACING

The boring of the brass and the facing off of the babbitted face are performed in the double spindle machine shown at the bottom of the page in Fig. 6, where two boxes are ma-

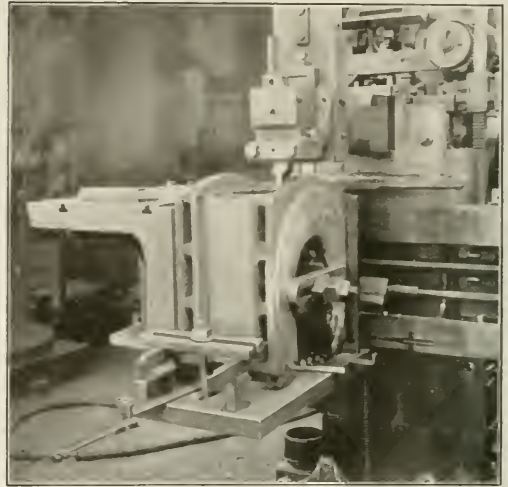

Fig. 5—Planing End of Boxes in Draw Cut Shaper

chined simultaneously, the spindles being set, in this case, at opposite ends of the cross rail. The boxes are secured in the broad face chuck jaws and the practice is to first run two boring cuts down through the work.

The spindle and cutter are operated at 60 turns per minute for the boring cuts and a feed of $1/32$ in. per revolution is maintained. The depth of chip for the first or roughing cut is from $3/8$ in. to $1/2$ in. and for the finishing cut $1/32$ in. on a side. The long cutter shown in operation in Fig. 7 is used to finish the babbitted face of the box. This

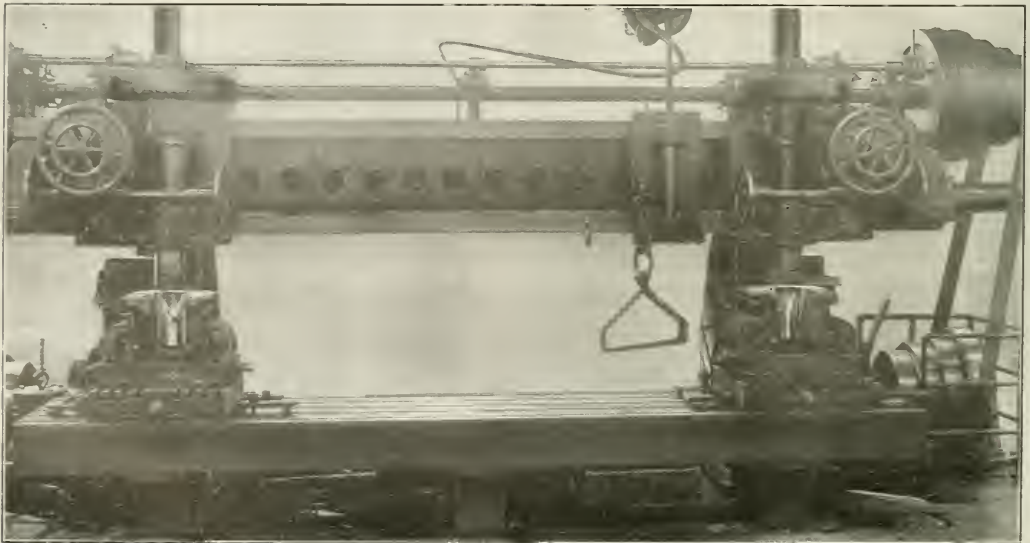

Fig. 6—Machine Used for Boring the Brasses and Facing the Boxes

cutter sweeps over the face of the work at the same speed as that of the boring cutter, or 60 revolutions per minute. When the face is nearly down to the desired thickness the finish on the surface is obtained without chatter by stopping

an instant when the job is completed and as quickly applied after the next box is ready for machining.

Cutting Tool Details.—Details of the facing and corner rounding tools are given in Figs. 10 and 11. It will be seen that the facing tool is made of $\frac{3}{4}$ -in. by $1\frac{3}{4}$ -in. stock and it has a total length of 16 in. The cutting portion is $10\frac{1}{2}$ in. long and is ground off on the edge to give a clearance of

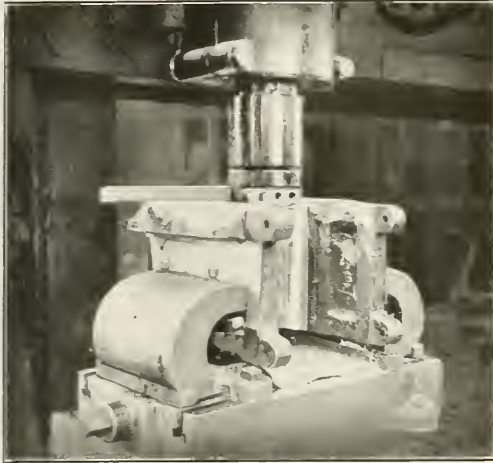

Fig. 7—Facing the Babbitted Surface of the Box

the spindle, then starting it slowly and letting it make two or three revolutions at slow rate of speed to allow the cutter to scrape the surface perfectly smooth. The rounding out of the $\frac{1}{2}$ -in. corner is done with the cutter shown in Fig. 8 which has a fillet of the desired radius. The speed of operation is the same as for the preceding cut.

Fig. 9 is of interest as showing one of many guards used on different machines in this plant. The guard is especially

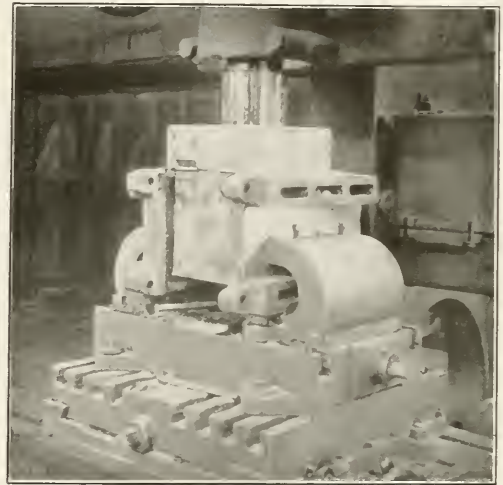

Fig. 9—Safeguard for Preventing Chips from Flying from the Boring Tool

two degrees while a small lip is formed on the cutting face by the concave groove indicated. Although the cut taken by this tool is a broad one the form of lip and clearance provide a clean smooth action. The radius tool, Fig. 11, is of the same size stock as the facing cutter. It is given more clear-

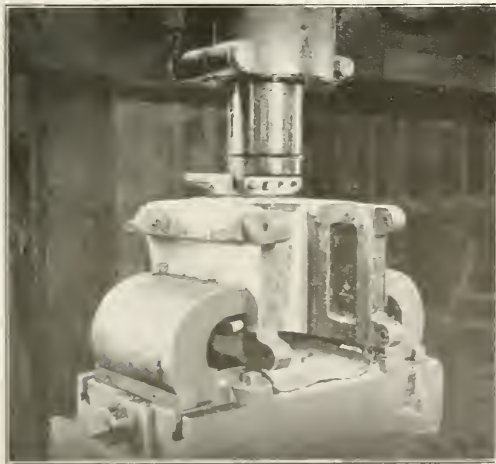

Fig. 8—Finishing the Corner Radius

serviceable on this boring machine owing to the tendency for brass chips to fly, especially when cut at the rate of speed referred to above. This guard is in the form of a sheet metal hood of cylindrical form which has at the front a swinging leaf which may be raised for observation of the work and tools and the whole affair can be slipped off of the work in

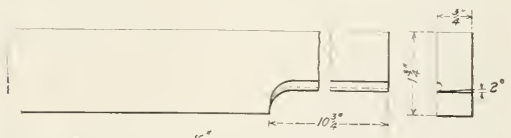

Fig. 10—The Facing Tool

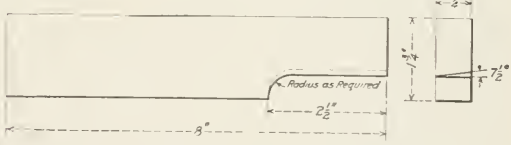

Fig. 11—The Corner Rounding Tool

ance or cutting rake however, the angle being $7\frac{1}{2}$ deg. as indicated in the sketch.

THE DIRECTOR GENERAL AT ALTOONA.—In a speech by Director General McAdoo to the railroad shopmen at Altoona, Pa., on September 12, he urged every shopman to put forth his best endeavor in getting locomotives in working order, saying: "Every idle locomotive is working for the Kaiser. Every live locomotive is an American soldier. Every moving locomotive is working for Uncle Sam."

MANUFACTURING SCRAP IRON INTO LOCOMOTIVE PARTS

BY PAUL H. CAIN
Blacksmith Foreman, Michigan Central, St. Thomas, Ont.

FORM FOR BABBITTING CROSSHEAD SHOES

BY J. F. DONELLAN
Master Mechanic, Delaware & Hudson, Oneonta, N. Y.

The seriousness of the material shortage prevailing in Canada on account of the war has forcibly brought to our attention the necessity for reclamation and conservation. All broken and obsolete parts of locomotive and car equipment, consisting of brake beams, brake rods, levers, chains, bolts, nuts, pins, spring buckles, spring hangers, drawbars, arch bars, axles, frames and any scrap which may accumulate around the shops, are utilized in this process.

These parts are chopped or sheared into pieces not exceeding 12 in. in length, then piled on boards 12 in. by 12 in., each pile weighing about 200 lb. to 250 lb. The piles are then charged into a furnace of sufficient capacity to accommodate 12 piles at one time. They are then heated to the welding point and forged into slabs 2½ in. by 14 in. by 30 in. A pair of grab tongs suspended from a crane is used to handle the material from the furnace to the hammer.

Any number of these slabs are piled together, depending on the size of the forging desired and again welded into a billet, which in turn is forged into the desired shape.

From these billets are manufactured locomotive frames, engine and tender drawbars, main equalizers for the spring rigging, valve motion links and some other small parts. In forging engine and tender drawbars, four slabs are piled together by using a porter bar, welded and forged in the center in one heat and the ends welded, formed and the hole punched with one extra heat each.

One of the best tests we have found for this material is the manufacture of valve motion links. The finished link is carbonized and the heat treatment has proved successful in all cases. The practice which we have found to give the best results in carbonizing these links is as follows:

After being heated in the carbonizing furnace for at least 14 hours the box should be removed and allowed to cool. The decalescence point for iron is about 1,650 deg. F., while the decalescence point for carbon steel is 1,440 deg. F. In order, therefore, to secure a refined grain iron on the inside of the case, reheat the link to the decalescence of iron and then quench in water. In order to get the decalescence of the carbon steel case, reheat to about 1,440 deg. F. and quench. This gives both a refined grain of the iron in the core and a satisfactory steel case.

This method of utilizing scrap has proved a great saving. The most important point is to have a good furnace.

The drawing shows in detail an adjustable form for re-babbitting cross-head shoes of the two-bar guide type, which is in use at the Oneonta shops of the Delaware & Hudson. The customary practice of babbitting these cross-head shoes requires that the surfaces be finished to size after being poured. With the adjustable guide this becomes unnecessary and the shoes are ready for service immediately after the

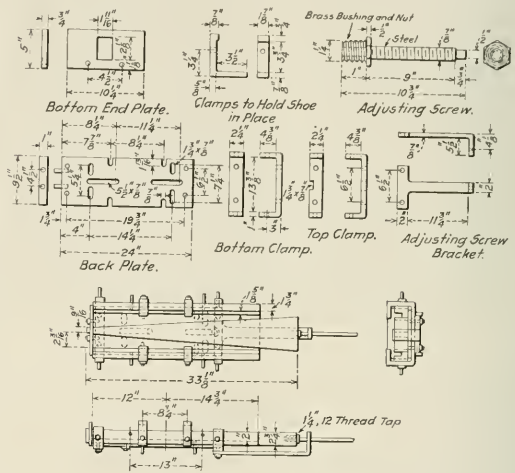

Details of an Adjustable Form for Rebabbitting Crosshead Shoes

babbitt is applied. Our experience has been that crosshead shoes rebabbitted in this manner last much longer than when the babbitt is applied in such a way that it is necessary to plane them afterwards. The planing very frequently loosens the babbitt and the removal of the hard outer skin leaves a comparatively soft wearing surface.

The method of operating the form and the details of its construction will readily be understood from an inspection of the drawing.



Scrap Iron Cut and Piled Ready for Heating

NEW DEVICES IN SOO WHEEL SHOP

Shifting Platforms at Press and Automatic Discharging Axle Carrier Add to Efficiency of Plant

THE methods of handling work in the wheel shop of the Minneapolis, St. Paul & Sault Ste. Marie at Minneapolis were described in these columns a few years ago.* Since this article was published, however, a number of interesting devices have been added to the equipment which have materially increased the capacity of the shop. Although the plant is comparatively small it has handled as many as 2,200 pairs of wheels in one month. The principal alterations made since the previous article consist of the addition of devices for facilitating the work of the dismounting press and for handling material to and from the machines.

The wheel dismounting press is fitted with attachments which make it possible to handle wheels very rapidly and it has been found desirable to arrange the track leading to the press to accommodate a larger number of wheels than could be placed on a single track, so a gauntlet has been installed. At the end where the wheels are received guides are provided so that the wheels when unloaded from the cars can readily be placed on the rails.

The wheels as they come to the other end of the tracks are not in the proper position to roll into the press, and to bring them in line a shifting platform has been installed in the floor. This platform, which is shown in Fig. 2, extends transversely a little more than the width of the track. Opposite the two inner rails are dogs, *AA*, which set about $\frac{1}{2}$ in.

from either track they strike one of these dogs. Pressing down the right hand dog causes the platform to move to the right one-half the distance between the rails, thus bringing

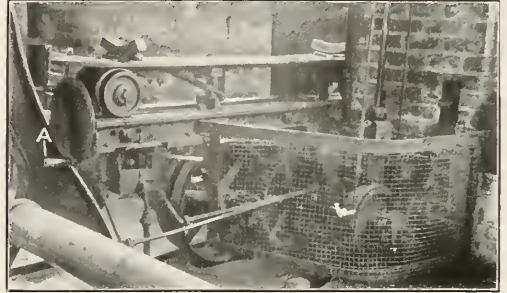

Fig. 2—Axle Carrier and Driving Mechanism

the wheel in line with the press. The left hand dog likewise moves the platform to the left. As the wheels roll off they press one of the dogs, *BB*, bringing the platform back to the original position.

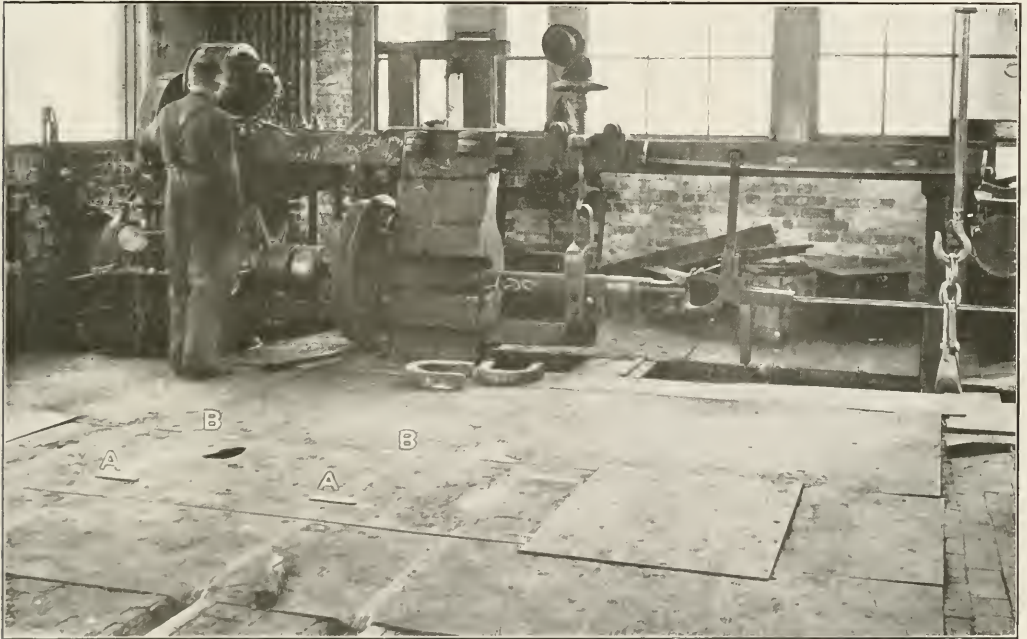

Fig. 1—Wheel Dismounting Press; Shifting Platform in the Foreground. Axle Carrier at the Right.

above the platform and operate valves controlling air cylinders under the floor. As the wheels roll on the platform

*See *Railway Age Gazette*, Mechanical Edition, issue of January, 1914, page 33.

Another novel device is the carrier which is used for disposing of the scrap axles. Axles which are still serviceable are picked up by a jib crane and stored in the shop to be used again, while those which are to be discarded are put outside

the shop. To reduce the labor of handling these scrap axles a hydraulically operated carriage has been designed. This carriage, which is illustrated in Fig. 2, runs on a track elevated about 2½ ft. from the floor. It is attached to an endless wire cable operated through gearing from a long cylinder and is thus driven in either direction. The handle controlling the cylinder is located at the end of the wheel press.

An ingenious arrangement is used for dropping the axles

running lengthwise of the car and the portion which projects beneath the floor of the carrier has a lug on either side, shown at A in Fig. 3. Between the lugs and the floor of the carriage are wedge shaped members, B, extending under both supports. These are free to move longitudinally but are fastened to a link, C, pivoted at the center of the carriage. Thus when either member moves in one direction the other moves in the opposite direction, and the axle support is tipped to one side or the other.

Between the rails on which the carriage rolls, and extending its entire length, is a shaft operated by a crank in the shop, as shown at A in Fig. 2. This shaft carries four

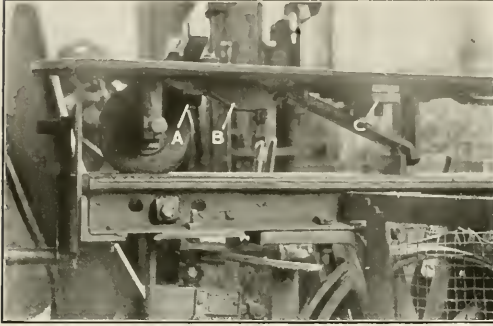

Fig. 3—Details of Device for Dumping Axles

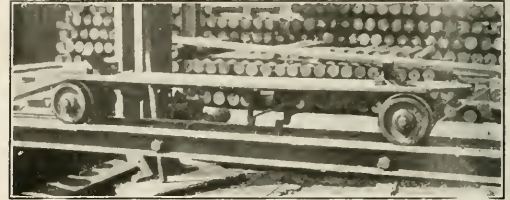
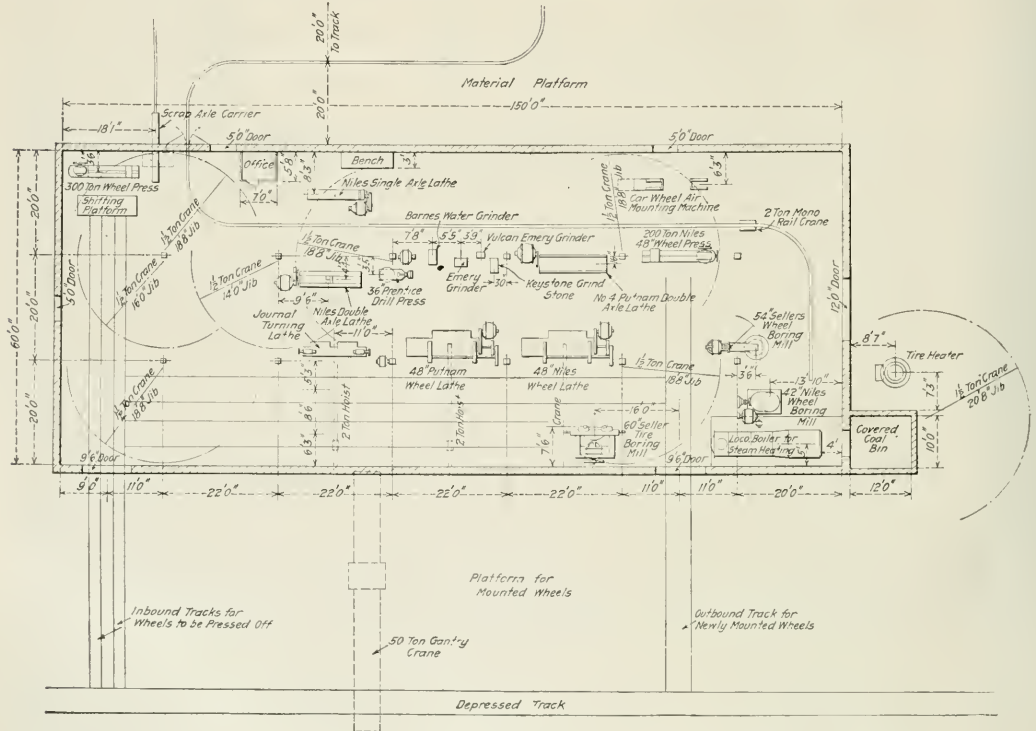

Fig. 4—View of Carrier Showing Position of Supports and Wedges After Discharging Axle

at the proper position on the platform outside the shop. Above the floor of the axle carrier are a pair of supports on which the axle is placed. (See Fig. 2.) The top of these supports forms a broad V. The center is pivoted on an axis

stops, spaced about nine feet apart. The dial at the end of the shaft has eight positions, two for each stop. When the dogs are placed at 45 deg. to the vertical on either side, they are in position to strike the wedges. When the carriage moves out and strikes the dog, the supports are tipped and the axle is discharged on one of eight piles, four on each side of the



General Arrangement of Tools in the Wheel Shop of the Minneapolis, St. Paul & Sault Ste. Marie, at Minneapolis, Minn.

track. The axle carrier is shown in Fig. 4 just after an axle has been dumped. The valve controlling the hydraulic cylinder is then reversed starting the carriage traveling back. When it reaches the shop a stop just above the rails, plainly

In order to conform to the circle of the house, the sections of the track over adjoining pits are placed at a slight angle to each other, which, however, is not sufficient to interfere with the proper operation of the hoist trolley.

It is frequently necessary to rig up a temporary suspension for a hoist to remove sand boxes and other parts from the top of the boiler. This requires considerable time and

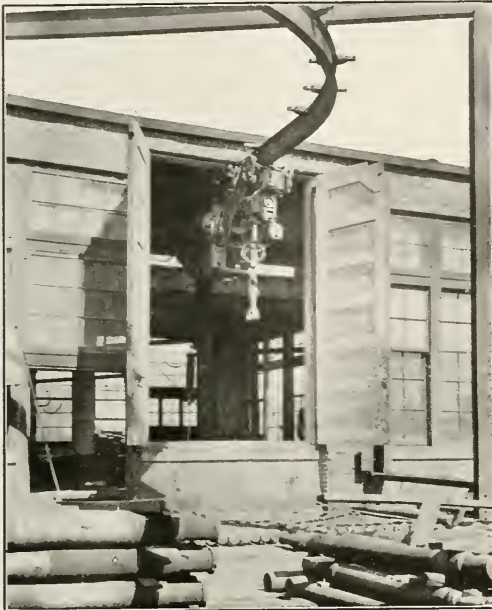

Fig. 5—Overhead Monorail Crane Serving Shop and Storage Platform

shown in Fig. 2, brings the support back to the normal position ready to receive another axle.

One of the noteworthy features of the layout of this shop is the overhead mono-rail crane Fig. 5 which serves the platform where new material is received and also the machines along two sides of the shop. The amount of trucking required has been largely reduced by the direct crane service from the material platform to the machines, which is made possible by placing large doors in the shop walls through which the crane passes.

ENGINEHOUSE TROLLEY HOIST

BY E. A. M.

A scheme for attaching and supporting the tracks for a one-ton roundhouse trolley hoist is shown in the accompanying drawing. The details as shown are designed to suit the conditions in a concrete building, but the idea could be equally well adapted to enginehouses of other types of construction.

The essential feature is the cantilever support, which is built up of two 4-in., 5.25-lb. channel tension members and two 3-in., 4-lb. struts, the two members being joined at the outer end by means of 1/4-in. gusset plates and attached to special castings at their inner ends, designed to conform to the shape of the pillar. The trolley track is an 8-in. I-beam, with flanges four inches wide, and where designed to span more than one stall, the ends are joined under the supporting truss by means of a 1-in. plate, riveted across the lower flanges of the 4-in. channel members of the truss and to the top flanges of the adjoining I-beams. A short 1/4-in. plate is attached by struts to the lower flanges of the channel.

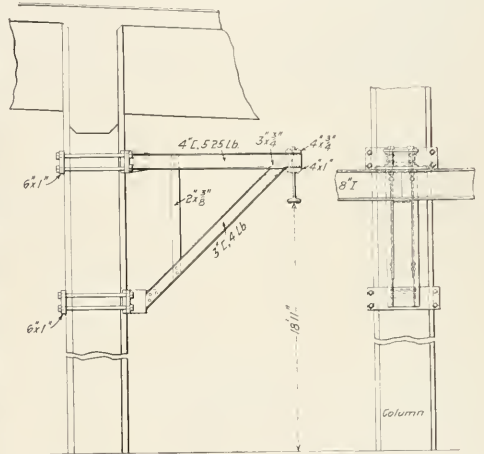

Trolley Hoist Track Supported from Enginehouse Columns

is often very inconvenient. A trolley hoist spanning one or more stalls, as local conditions dictate, provides a convenient means for handling this class of work with a minimum expenditure of time.



Courtesy of New York World

Buy Bonds and Keep Him on the Run

Have You Subscribed to Your Limit?

SETTING ECCENTRICS BEFORE ENGINES ARE WHEELED

BY F. J. SCHENCK

Master Mechanic, Natalbany Lumber Company, Hammond, La.

It is still the practice in many shops to delay the setting of eccentrics on Stephenson valve motion until the engine is wheeled and the valves run over. This is usually at a time when the other work is nearly completed and the valve man is rushed to get the engine out of the shop. Much time can be

If the lower rocker arm has backset as at *D*, the procedure is slightly different since, strictly speaking, the eccentric is set relative to the center line of motion, which is a line drawn through the center of the hole in the lower rocker arm and the center of the main axle when the top arm is vertical. Since the lower rocker arm is placed at right angles to the center line of motion, as at *D*, the angle which the center line of motion makes with the horizontal is equal to the angle the lower arm makes with the vertical; then angle *x* equals angle *y*. Draw the center line of motion *RS* through the center of

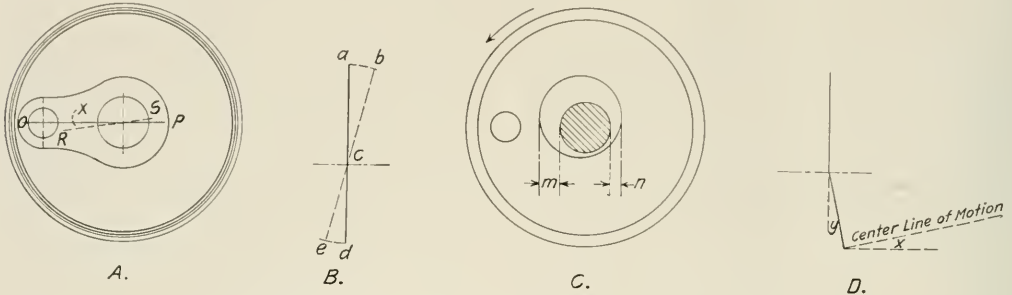

A Method of Fixing the Location of Eccentric Before Wheeling the Engine.

saved by setting and keying the eccentrics before the engine is wheeled, not to mention the probability of getting a better job.

After measuring the lap of the valve and determining the lead wanted in full stroke, measure the length of the rocker arms and if of unequal length make full scale line drawing of the arms, as at *B* in the sketch, and lay off *ab* equal to the lap of the valve plus the lead. Draw the rocker arm in position *bce* and measure the distance *ed*. This is equal to the linear advance of the eccentric. If the rocker arms are of equal length, the linear advance of the eccentric is equal to the lap plus the lead.

Scribe line *OP* on the wheel through the center of the axle

the axle as shown at *A*, making the angle *x* equal angle *y*. Level the line *RS* instead of line *OP*, and proceed as before.

RATTLER FOR FLEXIBLE STAYBOLT CAPS

BY S. A. R.

In the drawing is shown a rattler which was designed especially for cleaning flexible staybolt caps. The drum is 16 in. in diameter by 29 3/4 in. long, inside, and is made of 1/4-in. tank steel. Access to the interior is obtained through a door opening 8 in. wide by 18 in. long. The drum is mounted on brackets of 3/4-in. plate, which in turn rest upon

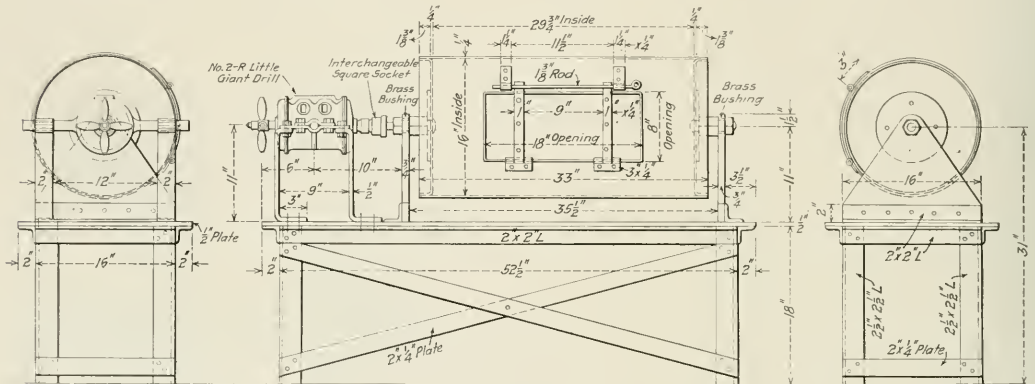

Flexible Staybolt Cap Rattler.

and the center of the crank pin, as shown at *A*, and place the crank pin on the center by leveling line *OP* with a spirit level. Place the eccentric in approximately proper position relative to the crank pin and drop lines over the eccentric and axle, as shown at *C*. If the rocker arms are indirect and the forward motion eccentric is being set, move the throw of the eccentric toward the crank pin until one-half the difference between *mn* is equal to *ed*. Mark the eccentric in this position and key to the axle.

a table 31 in. high, built up of angle sections and plates. A No. 2-R Little Giant drill motor is used to drive the drum. The motor is supported by its handle, which rests in suitable brackets provided at one end of the table. The connection between the motor and the drum shaft is made by means of a square socket which slips over the square end of the shaft and is made with a standard tang to fit the drill socket. The bearings for the drum shaft in the supporting brackets are fitted with brass bushings.



STEAM HEAT END VALVE WITH AUTOMATIC DRIP

In relieving the condensation at the rear end of passenger train heating lines the general practice has been to open the end valve slightly. This, however, has not proved satisfactory and many different schemes have been devised to take care of this drip automatically. All of these have been arranged to drain through the hose and have frequently caused freezing and decay of the hose. The Gold Car Heating & Lighting Company, New York, has recently developed a new end valve, known as the Acme valve No. 1126, in which the drip is automatically relieved through the valve itself, thus eliminating the continual dripping through the hose.

Referring to the sectional view of the valve, it will be seen that it is of the piston type, similar to existing Gold end

for years. The area of the passage through it is so large that it offers less resistance to the flow of steam than the train line itself.

The seats of the valve are renewable and can be replaced without disconnecting any piping.

In addition to relieving the hose of the effect of the con-

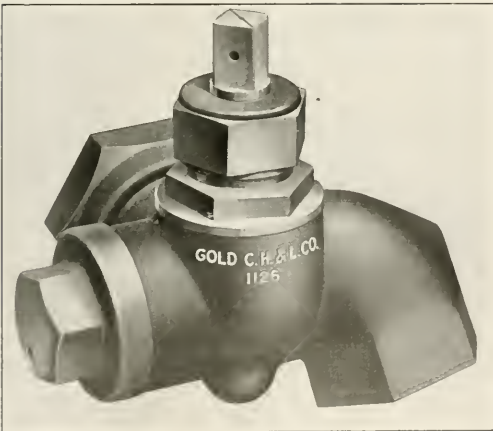

End Valve with Automatic Condensation Drip Port

valves. In this case the piston is double seated with a composition seat at each end. When the valve is closed, piston *B* is forced to the right by the cam on spindle *H*, thereby automatically opening the drip-port. When the valve is in the open position, the piston is forced to the left, the seat on this end forming a tight joint which automatically closes the drip-port. A quarter turn fully opens or closes the valve, and it cannot be jarred from its set position by the vibration of train, or unseated by the steam pressure. In the drip-port is provided an adjusting screw *G* for varying the opening.

The valve is substantially built, the body of iron and the cam and spindle cast in one piece. The spindle is short and of large diameter and should keep in perfect alignment

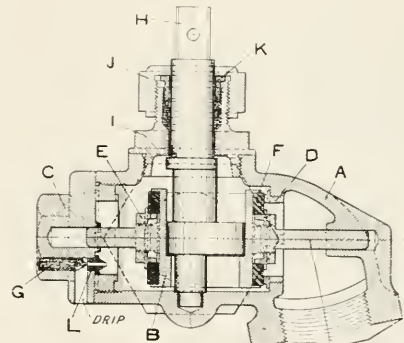

Sectional View of the Acme End Valve

tinual drip incident to the relieving of the condensation through the hose coupling, it is also a protection to the trainmen when uncoupling the hose, as the opening between the train line and the hose is tightly closed when the valve is shut.

FORGED SUPERHEATER RETURN BENDS

The Locomotive Superheater Company, New York, a short time ago perfected a process of forging or swaging the return bends on superheater units from the unit pipes without



Steps in Forming Forged Return Bends in Superheater Units

the use of any form of autogenous welding. The steps in the process are shown in the illustration. The first step splits and machine-welds the ends of the pipes together and is

carried on in a forging machine. The next step forms what is known as a preliminary swage and the return bend is then placed in a special swaging or forging machine and the completed bend is formed. The final step consists of cutting off the short extended butt, pressing the return bend back into shape so that there is no greater thickness than the outside diameter of the pipe, and smoothing the end off with an air hammer. The cut sections show the character of the completed return bends. As previously stated, there is no oxy-acetylene or electric welding used, the entire process being a machine forging job. These return bends are formed on the long pipes of the units and not on short ones as shown in the illustration, these short pipes being employed merely for the purpose of illustrating the process. Each unit thus becomes a continuous pipe from the saturated to the superheated steam chambers of the header.

JOLIET JOURNAL BOX

A journal box with a new type of lid combining several desirable features is now being manufactured by the Joliet Railway Supply Company, Chicago. The important points of the design of this box are the complete sealing of the outer opening of the box by the lid, the use of a spiral spring for holding the lid in place, and the interchangeability of the standard M. C. B. box lid.

The complete seal on the outer edges of the Joliet journal box, with flanges on the lid both inside and outside, makes the lid dust and water proof. This is made possible

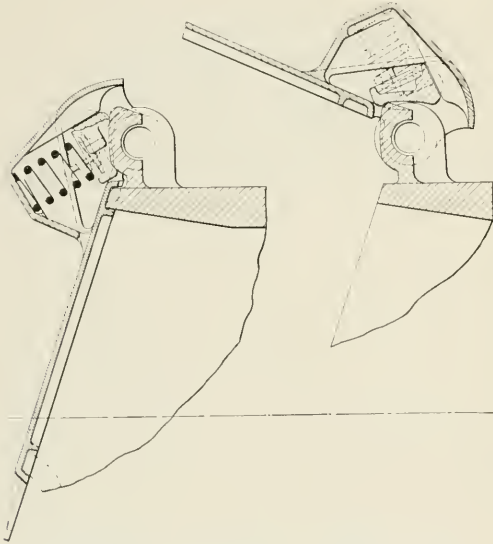

Lid of Joliet Journal Box in Open and Closed Positions

by placing the lid operating mechanism beyond the face of the box. A spiral spring and shoe are placed in a cap at the top of the lid. The shoe bears on the lug which is of a contour similar to that of the lug on the standard M. C. B. journal box. The arrangement is such that the spring holds the box firmly in either the open or the closed position. In case the original lid becomes broken or lost, the standard M. C. B. journal box lid can be applied.

NEW LOCOMOTIVES.—The Railroad Administration will soon place orders for locomotives for 1919 delivery.

TIGHT RIVETS

The American Flexible Bolt Company, Pittsburgh, Pa., has recently placed on the market a new type of rivet called the "American" rivet. It has a rounded head, which when driven into the work will more completely fill the rivet hole than the ordinary type of rivet. One of the illustrations

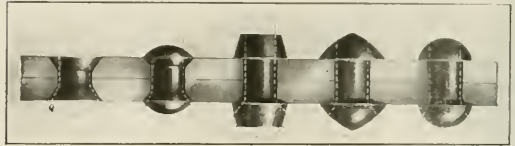

Various Types of Heads Can Be Formed from the One Head of the "American" Rivet

shows actual photographs of sections cut through riveted plates, in which both the ordinary type of rivet and the "American" rivet were used. With the ordinary type of rivet it is practically impossible to upset the metal directly under the head on account of the square shoulder. With the "American" rivet the metal is made to flow under the head

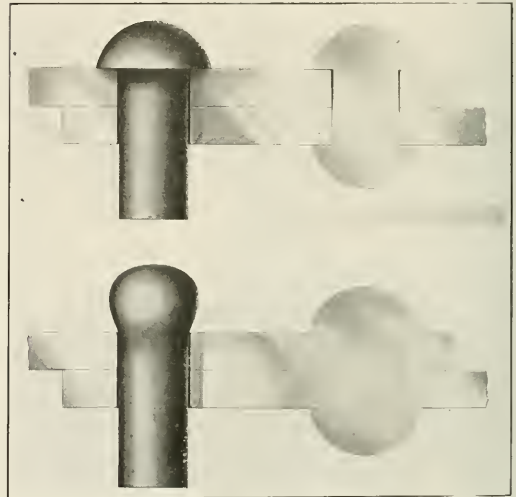

Sections Through Plates Riveted by the Ordinary Type of Rivet and the "American" Rivet Showing How the "American" Rivet Completely Fills the Rivet Hole

and fill the rivet hole as the head is upset in the process of riveting. By thus filling the rivet holes more perfectly, the "American" rivet requires less calking and less stock is required to form the different types of heads. No sharp corners are formed in its manufacture to weaken it. Any desired shape of head may be obtained from the one stock pattern.

AN UNUSUAL AIR COMPRESSOR.—Paradoxical as it may seem, there is a two-stage steam-driven air compressor at Newport, R. I., that shows a volumetric efficiency of 116.8 per cent, as shown in the records of tests on file in Washington. The reason is given by a writer in Power as follows: The cold-air inlet is a long pipe extending to the river bank, and when suction starts in the compressor it sets in motion the long column of air in the inlet pipe, the momentum of which partly compresses the air in the low-pressure cylinder before the inlet valves are completely closed.

Railway Mechanical Engineer

(Formerly the RAILWAY AGE GAZETTE, MECHANICAL EDITION
with which the AMERICAN ENGINEER was incorporated)

PUBLISHED ON THE FIRST THURSDAY OF EVERY MONTH BY THE
SIMMONS-BOARDMAN PUBLISHING COMPANY

EDWARD A. SIMMONS, *President* M. H. WIUM, *Secretary*
HENRY LEE, *Vice-President and Treasurer* L. B. SHERMAN, *Vice-President*
WOOLWORTH BUILDING, NEW YORK, N. Y.
F. H. THOMPSON, *Business Manager*, CHICAGO.

Chicago: Transportation Bldg. Cleveland: Citizens' Bldg.
Washington: Home Life Bldg.
London: Queen Anne's Chambers, Westminster.

ROY V. WRIGHT, *Editor*
R. E. THAYER, *Managing Editor*
C. B. PECK, *Associate Editor* A. F. STUEBING, *Associate Editor*
C. W. FOSS, *Associate Editor*

Entered at the Post Office at New York, N. Y., as mail matter of the second class.

Subscriptions payable in advance and postage free; United States, Canada and Mexico, \$2.00 a year; Foreign Countries, \$3.00 a year; Single Copy, 20 cents.

WE GUARANTEE, that of this issue 7,000 copies were printed; that of these 7,000 copies 6,086 were mailed to regular paid subscribers, 60 were provided for counter and news companies' sales, 191 were mailed to advertisers, 65 were mailed to employees and correspondents, and 598 were provided for new subscriptions, samples, copies lost in the mail and office use; that the total copies printed this year to date were 77,750, an average of 7,775 copies a month.

THE RAILWAY MECHANICAL ENGINEER is a member of the Associated Business Papers (A. B. P.) and the Audit Bureau of Circulations (A. B. C.)

ANNOUNCEMENT

Because it is necessary to conserve fuel, transportation and materials, the War Industries Board has limited the available paper supply; has asked us to discontinue subscriptions upon expiration unless they are renewed and paid for; cut down office supply, advertisers' copies and eliminate every source of needless waste. This order becomes effective at once.

We gladly comply with the full instructions from the War Industries Board with the full assurance that our subscribers and advertisers will give us every cooperation. We urge our subscribers particularly to watch the expiration date of their subscription since it will be impossible to continue their subscription after expiration or furnish back copies in case it lapses.

The Western Railway Club, at its meeting on September 16, elected L. P. Michael, chief draftsman, Chicago & North Western, second vice-president and A. F. Stuebing, associate editor *Railway Mechanical Engineer*, secretary and treasurer to fill out unexpired terms.

L. S. Carroll and F. A. Bushnell, members of the regional purchasing committee for Northwestern railroads, left Chicago on August 7 for an extended trip throughout the Northwestern region for the purpose of investigating the organization and practices of the store departments of the roads under federal control in that section of the country.

The Master Car Builders' rules of interchange, as revised June, 1917, have been extended to remain in effect until further notice. This announcement is made in circular No. 14 issued August 26. The extension applies also to circulars interpreting or modifying the 1917 rules. Notice will be given in advance of the date on which the 1918 code of rules is to go into effect.

Studies are being made by the United States Railroad Administration to determine whether the adoption of an equitable and universal plan for the compensation of employees, in case of injury or death, and provision of life, health and old age insurance is practicable. There are difficulties in the way arising from the existence of the present pension and insurance plans, but it is expected that they can be overcome.

The shopmen of the Louisville & Nashville have been "organized," and, according to a Louisville paper, about 97 per cent of the several thousand men in the different shops of the road have joined unions representing their several crafts. The men will work under what is called the Southeast agreement, and papers were signed on August 15

by the superintendent of machinery, representing the road, and by leaders of the several crafts.

M. C. B. Questionnaire on the Use of Wood in Car Construction

The Master Car Builders' Association, acting in conjunction with the American Wood Preservers' Association and the Forest Products Laboratory of the United States Forest Service, has sent to the members a circular asking for information necessary to permit a thorough study of the proper utilization of wood in car construction and the development of methods of protecting timber against decay. The questionnaire also asks for data concerning the results obtained by using hard woods and uncommon species of wood in car building, the efforts made to save old car lumber and the comparative life of single sheathed and double sheathed box cars of similar weight and capacity.

Government Interested in Carbocoal

The United States Fuel Administration has issued press notices to the effect that the United States Government has become interested in the establishment of a plant for the manufacture of Carbocoal at Clinchfield, Va. The plant, which is now in the preliminary stages of construction, will have a capacity of treating several hundred thousand tons of bituminous coal annually. The plans for the plant and the grounds allow for an eventual capacity of 1,500,000 tons per year. By a new process of low temperature distillation, invented by Charles H. Smith and described in the *Railway Mechanical Engineer* for March, page 175, bituminous coal is treated in such a manner as to recover greater quantities of the valuable by-products, such as toluol, sulphate of ammonia and valuable oils. From the residue is made a valuable smokeless fuel, in the form of briquettes. Tests of Carbocoal by the Navy disclose that it contains less than four

per cent volatile matter, rendering it practically smokeless. The new plant, which is expected to be in operation early in 1919, is being built near the junction of the Carolina, Clinchfield & Ohio and Norfolk & Western. The Fuel Administration and the Ordnance Bureau of the War Department are co-operating in the construction of the plant.

Results of M. C. B. and M. M. Letter Ballot

The outcome of the voting on questions ordered submitted to letter ballot at the annual meeting of the Master Car Builders' Association has been announced in Circular No. 7, issued by the secretary. All of the proposals submitted to a vote were carried. The most important matter considered was the adoption of the No. 10 contour line for the type D coupler. This was adopted with but a single dissenting vote. The design of the 6-in. by 8-in. shank for the type D coupler was also carried by a large majority. The gages to insure interchangeability of parts and specifications for the purchase and acceptance of couplers, knuckles, locks, and other parts were also adopted. The modifications of certain specifications proposed by the committee on Tests and Specifications for Material were carried. It was also voted to add to the interchange rules a provision making the use of metal safety blocks mandatory and prohibiting the use of wooden safety blocks. The remainder of the twenty-two questions related to minor changes in the standards and recommended practices of the association.

The twenty questions appearing on the letter ballot of the Master Mechanics' Association were all adopted. The majority of these were submitted by the Committee on Specifications and Tests for Material. Several new specifications were adopted as recommended practice and a number of others were revised. The overall width of journal bearings was increased and several of the recommended practices of the association were advanced to standard.

Revision of M. C. B. Rules for 1918-19

The changes in the Master Car Builders' Rules of Interchange for freight cars, for the coming year, proposed by the Arbitration Committee and referred to the Railroad Administration, have been passed on. The new rules as affecting bills for repairs went into effect on October 1, 1918, although they will probably not be in the hands of all the roads until some later date.

The rules have been retained as nearly as possible in the present form, so far as they apply to roads not under federal control. To take care of interchange between roads operated by the Railroad Administration, a preface has been added. Article I of the preface covers necessary changes in the rules to conform to Circular 7 of the Division of Operation. Article II provides for the elimination of defect carding between roads under federal control, while Article III eliminates billing for certain minor items between roads under federal control. Article IV covers the proper charges for re-weighting and stenciling cars belonging to government controlled roads.

The following list gives the items affected by the principal modifications in the rules: rule 3, section b, paragraph 2, covers the Railroad Administration's requirements with regard to standards for certain repairs; rule 7 provides for a standard original record of repairs made and the method of handling; rules 32 and 43, covering the responsibility for certain repairs, have been altered. Under rule 101 average credit prices have been provided for certain air brake parts and also for brake beams. The labor allowance for ordinary repair work has been raised to 58 cents an hour and for work on tanks of tank cars to 68 cents. Settlement prices for destroyed cars have been increased to meet present conditions. The percentage to be added to bills, as provided under rule 106, has been reduced from 35 to 30.

PERSONAL MENTION

FEDERAL ADMINISTRATION APPOINTMENTS

T. E. PARADISE, division master mechanic and trainmaster on the Chicago, Burlington & Quincy, with headquarters at Centerville, Iowa, has been appointed mechanical assistant on the regional director's staff of the Central Western region, with headquarters at Chicago.

GENERAL

E. R. BATTLE, master mechanic of the Grand Trunk, at Montreal, Que., has been appointed superintendent of motive power, eastern lines, with headquarters at Montreal.

R. J. NEEDHAM has been appointed mechanical and electrical engineer of motive power and car departments of the Grand Trunk, with headquarters at Montreal, Que.

F. L. CARSON, superintendent of motive power of the San Antonio & Arkansas Pass, has been appointed assistant mechanical superintendent under federal control, with headquarters at Yoakum, Tex.

WILLIAM A. COTTON, chief clerk to the general mechanical superintendent of the Erie, has been appointed assistant to the general mechanical superintendent, with office at Meadville, Pa.

WILLARD KELLS, assistant general superintendent of motive power of the Atlantic Coast Line, with office at Wilmington, N. C., has been appointed general superintendent of motive



W. Kells

power, with headquarters at the same place, succeeding R. E. Smith. Mr. Kells was born on February 4, 1868, at Dennison, Ohio, and was educated in the grammar and high schools of Cleveland, Ohio. He began railway work on March 1, 1888, as a machinist apprentice with the Erie Railroad at Susquehanna, Pa., and later was promoted to gang foreman at Meadville, Pa. On October 1, 1893, he was appointed general foreman of the same shop and in January, 1896, was promoted to master mechanic, Mahoning division, with headquarters at Cleveland. In August, 1898, he was transferred as master mechanic to the Lima and Chicago divisions, with headquarters at Huntington, Ind. From February 1, 1899, to April 1, 1903, he was master mechanic of the Meadville division at Meadville, Pa., and on the latter date resigned from the service of the Erie to become assistant master car builder of the Union Tank Line, with office at New York. The following month he was appointed master mechanic of the Auburn, Pennsylvania and Seneca divisions of the Lehigh Valley, with headquarters at Sayre, Pa. He was later transferred to Buffalo, N. Y., in the same capacity and was given supervision of all divisions in New York State. He resigned from the service of the Lehigh Valley in December, 1910, to go to the Atlantic Coast Line as assistant to the general superintendent of motive power, with headquarters at Wilmington, N. C., and one

year later was appointed assistant general superintendent of motive power, which position he held until his recent appointment.

M. C. FULLER, traveling fireman of the Minneapolis, St. Paul & Sault Ste. Marie, has been appointed assistant fuel supervisor.

J. C. GARDEN has been appointed superintendent of motive power shops of the Grand Trunk at Stratford, Ont.

RAYMOND A. GREENE, formerly a chemist with Armour & Co., Chicago, has been appointed chemist and engineer of tests of the Chicago & Alton, with headquarters at Bloomington, Ill.

J. HERRIGAN, superintendent of motive power of the Elgin, Joliet & Eastern, at Joliet, Ill., has been appointed superintendent of motive power also of the Chicago, Milwaukee & Gary.

J. R. LECKIE, assistant master mechanic of the Grand Trunk, at London, Ont., has been appointed assistant to the superintendent of motive power of the Ontario lines, with headquarters at London.

A. C. LONGDO has been appointed assistant fuel supervisor of the Minneapolis, St. Paul & Sault Ste. Marie.

M. P. LYBECK has been appointed assistant fuel supervisor of the Minneapolis, St. Paul & Sault Ste. Marie.

F. W. MAHL, director of purchases of the Southern Pacific, Pacific System, at New York, has been appointed corporate mechanical engineer of the Southern Pacific lines west of El Paso and Ogden, with headquarters at San Francisco, Cal.

GEORGE McCORMICK, superintendent of motive power of the Southern Pacific, now also has jurisdiction over the Western Pacific, the Tidewater Southern and the Deep Creek Railroad, with headquarters at San Francisco, Cal.

D. J. McCAIG, master mechanic of the Grand Trunk at Toronto, Ont., has been appointed superintendent of motive power of the Ontario lines, with office at Toronto.

A. McDONALD, assistant master mechanic of the Grand Trunk at Montreal, Que., has been appointed assistant to superintendent of motive power, with office at the Montreal shops.

C. E. PECK, master mechanic of the Southern Pacific at Brooklyn, Ore., has been appointed assistant superintendent motive power of the Oregon-Washington Railroad & Navigation Company, with headquarters at Portland, Ore., succeeding J. T. Langley, resigned to accept service elsewhere.

J. A. POWER, assistant general manager of the Southern Pacific, Texas Lines, has been appointed mechanical superintendent of all lines under the authority of W. B. Scott, federal manager, with headquarters at Houston, Tex.

J. R. POTTER, traveling fireman, has been promoted to assistant fuel supervisor of the Minneapolis, St. Paul & Sault Ste. Marie.

R. E. ROE, general master mechanic of the Gulf Coast Lines, has been appointed assistant mechanical superintendent of the New Orleans, Texas & Mexico, the Beaumont, Sour Lake & Western and the St. Louis, Brownsville & Mexico, with office at Kingsville, Tex.

J. VASS, assistant master mechanic of the Grand Trunk at Allandale, Ont., has been appointed assistant to the superintendent of motive power of the Ontario lines, with headquarters at Allandale.

A. D. WILLIAMS, superintendent motive power of the Southern Pacific, Northern district, now also has jurisdiction over the Western Pacific, Tidewater Southern and Deep Creek Railroads, with headquarters at Sacramento, Cal.

G. M. WILSON, master mechanic at the Montreal locomotive shops of the Grand Trunk, has been appointed superintendent of motive power shops at Montreal, Que.

A. WOODHALL has been appointed assistant fuel supervisor of the Minneapolis, St. Paul & Sault Ste. Marie.

MASTER MECHANICS AND ROAD FOREMEN OF ENGINES

J. J. DOWLING, general master mechanic of the Great Northern, with headquarters at Great Falls, Mont., has been appointed general master mechanic of the Eastern district, with headquarters at St. Paul, Minn., succeeding G. A. Bruce, deceased.

A. B. FORD, division master mechanic of the Great Northern at Great Falls, Mont., has been promoted to general master mechanic, with headquarters at Great Falls, to succeed J. J. Dowling, transferred.

MICHAEL A. GLEESON, whose appointment as master mechanic of the Baltimore & Ohio at New Castle Junction, Pa., was announced in the *Railway Mechanical Engineer* last month, was born at Piedmont, W. Va., on November 6, 1885, and was educated at St. Peter's School, Westernport, Md. His entire railroad service has been with the Baltimore & Ohio. He was employed in September, 1901, as an engine cleaner, later for eight years was a machinist, and in September, 1914, he was made a foreman. In February, 1916, he was promoted to the position of general foreman at Grafton, W. Va.; a year later he was transferred to Keyser, W. Va., and several months later to Philadelphia, Pa. In December, 1917, he was appointed assistant master mechanic at New Castle Junction, and held this position until he received his recent appointment.

D. M. McLAUCHLAN, assistant master mechanic of the Southern Pacific at Brooklyn, Ore., has been appointed master mechanic on the Portland division, succeeding C. E. Peck, resigned to go to another road.

J. A. McNULTY, railroad representative of the Anchor Packing Company at Chicago, has been appointed division master mechanic of the Chicago, Milwaukee & St. Paul at Dubuque, Iowa, succeeding G. T. Messer.

R. J. SPORSELLER has been appointed road foreman of engines on the Pennsylvania Railroad, Western lines, with headquarters at Lancaster, Ohio, to succeed J. L. Todhunter, transferred.

CAR DEPARTMENT

F. D. CAMPBELL, general car foreman of the Chicago, Milwaukee & St. Paul at Tacoma, Wash., has been appointed assistant master car builder of the lines west of Moberly, S. D., with headquarters at Tacoma, Wash.

W. L. DELANEY, car foreman of the Chicago, Milwaukee & St. Paul at Tacoma, Wash., has been appointed general car foreman at that point.

W. G. DENSMORE, car foreman of the Chicago, Milwaukee & St. Paul at Miles City, Mont., has been appointed general car foreman at that point.

CLYDE MEDLEY, assistant general car foreman of the Chicago, Milwaukee & St. Paul at Miles City, Mont., has been appointed general car foreman, with headquarters at Seattle, Wash.

FRANK D. SHOOK, car foreman of the Chicago, Milwaukee & St. Paul, has been appointed general car foreman at Spokane, Wash.

A. STRAND, car foreman of the Chicago, Milwaukee & St. Paul at Deer Lodge, Mont., has been appointed general car foreman at that point.

C. C. WILTS, car foreman of the Chicago, Milwaukee & St. Paul at Malden, Wash., has been appointed general car foreman at Harlowton, Mont.

SHOP AND ENGINEHOUSE

O. C. COHO has been transferred to the Pitcairn, Pa., enginehouse of the Pennsylvania Railroad as foreman, succeeding O. L. Zimmerman.

G. H. GJERTSEN has been appointed master welder of the Northern Pacific, in charge of electric and oxy-acetylene welding and cutting.

W. B. MELLON, assistant foreman of the Pennsylvania at the Twenty-eighth street shops, Pittsburgh, Pa., has been appointed enginehouse foreman of the same road at Youngwood, Pa.

F. RAVENA, roundhouse foreman of the Erie Railroad at Cleveland, Ohio, has been promoted to general foreman.

F. SVEC, fitting shop foreman at the Cleveland, Ohio, shops of the Erie Railroad, has been promoted to erecting shop foreman.

O. L. ZIMMERMAN, enginehouse foreman of the Pennsylvania Railroad at Pitcairn, Pa., has been transferred to Derry, Pa., as enginehouse foreman.

PURCHASING AND STOREKEEPING

E. T. BURNETT will perform the duties of purchasing agent of the Norfolk & Western until further notice, in addition to his duties as chairman of the Regional Purchasing Committee for the Pocahontas Region.

H. E. DUTTON, purchasing agent of the Green Bay & Western, has been appointed purchasing agent also of the Kewanee, Green Bay & Western, the Ahnapec & Western and the Waupaca-Green Bay, with headquarters at Green Bay, Wis.

C. H. KENZEL, purchasing agent of the Elgin, Joliet & Eastern at Chicago, has been appointed purchasing agent also of the Chicago, Milwaukee & Gary.

A. S. MCKELLIGON, general storekeeper of the Southern Pacific, with headquarters at San Francisco, Cal., has had his jurisdiction extended over the Western Pacific, the Tidewater Southern and the Deep Creek.

H. C. ROBINSON has been appointed purchasing agent of the Chicago Junction and the Chicago River & Indiana, with office at the Union stockyards, Chicago, succeeding S. Salter.

G. W. SAUL, purchasing agent of the Oregon-Washington Railroad & Navigation lines and the Yakima Valley Transportation Company, has been appointed purchasing agent also of the Northern Pacific Terminal of Oregon and the Pacific Coast, with headquarters at Portland, Ore.

F. W. TAYLOR, purchasing agent of the Southern Pacific Company at San Francisco, Cal., has been appointed purchasing agent of the Southern Pacific system, lines south of Ashland, Ore., the Western Pacific, the Tidewater Southern and the Deep Creek.

J. M. WAGNER has been appointed purchasing agent of the Copper Range and will make his headquarters at Houghton, Mich.

W. C. WELDON, purchasing agent of the Colorado & Southern, has had his jurisdiction extended to include the Denver & Salt Lake, with headquarters at Denver, Colo., succeeding A. L. Cochrane.

L. B. WOOD, purchasing agent and general storekeeper of the Southern Pacific, Texas lines, has been appointed general storekeeper of all lines under W. B. Scott, federal manager, with headquarters at Houston, Tex.

OBITUARY

G. A. BRUCE, general master mechanic of the Great Northern, Eastern district, with headquarters at St. Paul, Minn., died on August 26, at Minot, N. D.

C. W. VAN BUREN, who was killed in an automobile accident on August 25, at Canajoharie, N. Y., as was mentioned in these columns last month, was born on October 18, 1867, in Rensselaer County, N. Y. He was educated in the common schools, later attending night school in New York City. In 1889, he began railway work on the New York Central & Hudson River, and served as a carpenter at the West Albany shops until 1891. He was then appointed foreman; and two years later was given charge of the car department work on the Adirondack division at Herkimer, N. Y. In 1896, he was transferred to Utica in charge of car department work on the Adirondack and Mohawk divisions of the same road and the West Shore. He entered the service of the Canadian Pacific in July, 1905, as general inspector on the lines east of Port Arthur. The following year he was appointed divisional car foreman of the Eastern division, remaining in that position until July, 1909. He then served as master car builder of the Eastern lines of the same road at Montreal until May, 1911, and then went to the Union Stock Yard & Transit Company, Chicago, as assistant general superintendent, remaining in that position until January, 1915, and was then appointed general foreman of the Milwaukee Refrigerator Transit & Car Company at Milwaukee, Wis. In April, 1915, he returned to the service of the Canadian Pacific as general master car builder, which position he held until the time of his death.

ROBERT E. SMITH, general superintendent of motive power of the Atlantic Coast Line, with office at Wilmington, N. C., was instantly killed on August 25 by the accidental discharge



R. E. Smith

of a rifle which he was cleaning and it is supposed that he was not aware that the rifle was loaded. He was born on February 11, 1862, at Reading, Pa., and graduated from Phillips Academy, Andover, Mass., in the class of 1882. He began railway work later in the same year as a machinist apprentice on the Philadelphia & Reading. From 1885, to November of the following year, he was a draftsman on the Norfolk & Western, and then to October, 1890, was foreman of the same road at Norfolk, Va. He subsequently served as road foreman of engines for about two years and from 1892 to January, 1896, was general foreman of the Lambert Point shops of the same road. In January, 1896, he entered the service of the Atlantic Coast Line as fuel agent, and in February of the following year was appointed superintendent of motive power of the same road. From July, 1898, to March, 1905, he served as assistant to the general manager and since that time had been general superintendent of motive power.

CONDITION OF GERMANY'S ROLLING STOCK.—Writing in the Berliner Tageblatt on the present conditions of Germany's rolling stock, Herr Gothein, the Reichstag Deputy, says that of his many railway journeys during the last two years one out of every five was interrupted by engine breakdowns.

SUPPLY TRADE NOTES

Fred G. Zimmerman, assistant to the secretary of Harry Vissering & Co., and the Okadee Company, has been appointed acting secretary, succeeding Marshall E. Keg, granted a leave of absence.

F. J. O'Brien, mill manager at Milwaukee, Wis., for the Globe Seamless Tube Company of Chicago, was promoted on September 1 to general manager, with headquarters at Milwaukee.



F. J. O'Brien

representative. He was promoted to general sales manager in 1914, and in April, 1917, was appointed manager of mills, with headquarters at Milwaukee.

James A. Trainor, formerly assistant to the sales manager of the Baldwin Locomotive Works, has been appointed assistant general sales manager of the American Flexible Bolt

Company, with offices at 50 Church street, New York. Mr. Trainor started his business life with the Baldwin Locomotive Works and worked his way up through various departments to the position of assistant to the sales manager. In November, 1917, he entered the service of the United States government as a major in the Russian Railway Service Corps. This organization was sent to Russia to operate the Trans-Siberian Railway. Owing to the upheaval in Russia,



J. A. Trainor

part of this organization was recalled to the United States and Mr. Trainor again entered the service of the Baldwin Locomotive Works, resuming his position as assistant to sales manager, which position he held at the time of his recent appointment.

The Bettendorf Company announces the closing of its sales offices in Chicago and New York on September 1. Requests or communications to the company should be referred to the home office at Bettendorf, Iowa.

J. C. Weedon has been appointed railroad representative for the Anchor Packing Company, with headquarters at Chicago, to succeed J. A. McNulty.

E. P. Dillon, manager, power division, of the Westinghouse Electric & Manufacturing Company, at New York, has resigned to become general manager of the Research Corporation, New York.

The American Flexible Bolt Company of Pittsburgh, Pa., has opened a branch office at Cleveland, Ohio, in charge of L. W. Widmeier, who was formerly assistant general sales manager at the company's New York office.

L. C. Sprague, special railroad sales representative of the Chicago Pneumatic Tool Company, with headquarters at Chicago, has been promoted to district manager of sales for that company, at New York, succeeding Charles Booth, resigned. C. W. Cross succeeds Mr. Sprague.

B. H. Tripp, special representative of the Chicago Pneumatic Tool Company on the Pacific coast, has been appointed district manager of sales for the Pacific coast territory, with headquarters at San Francisco, Cal., succeeding M. W. Prisdler. The Los Angeles branch of the company will also come under Mr. Tripp's jurisdiction.

J. H. Rodger has been elected acting vice-president of the Safety Car Heating & Lighting Company, with office at Chicago. Mr. Rodger has been sales representative with that company since April, 1911, prior to which he was with the Standard Coupler Company and the Monarch Machine Company.



J. H. Rodger

A. Clark Moore, vice-president of the Safety Car Heating & Lighting Company, whom he succeeds, has been given a leave of absence for the duration of the war to accept a commission as major, in charge of aircraft production in the New York district. Major Moore was born January 18, 1880, and entered the railway supply business in the

New York office of the Safety Car Heating & Lighting Company in July, 1899. In 1906 he went with the Western Steel Car & Foundry Company and later with McCord & Co., returning to the Safety Car Heating & Lighting Company in August, 1907, remaining with that company in the positions of sales agent in New York, 1907; manager, Northwestern district, 1908; general manager, New York, 1911, and vice-president with headquarters in Chicago since June, 1913. Major Moore is a past president of the Railway Electrical Supply Manufacturers' Association.

Harry L. Barnitz announces that he has severed his connection with the International Oxygen Company as sales agent and is now conducting business under his own name as consulting engineer on oxygen and hydrogen, plant installation and technical processes for their uses. His office is at 617 West 152nd street, New York.

Robert F. Carr, president of the Dearborn Chemical Company of Chicago, has been commissioned major on the general staff in the department of purchases, storage and traffic of the army, with headquarters at Washington, D. C. Major Carr will work in conjunction with Lieut. Col. W. R. Roberts in connection with the standardization of army equipment.

John W. Foyle, vice-president of the Gustin-Bacon Manufacturing Company, Kansas City, Mo., has accepted a commission as major in the Quartermaster Corps, and reported to Washington on September 1. Mr. Foyle had been with the Gustin-Bacon Manufacturing Company five years, prior to which he was with the Missouri, Kansas & Texas.

Guy E. Tripp, formerly Colonel United States Army and head of the production division of the Ordnance Department, has been promoted to the rank of Brigadier General in the United States Army, and placed in control of the offices having charge of the production of ordnance material in their respective sections of the country. The district chiefs will report direct to General Tripp, who is succeeded as head of the production division by Col. C. C. Jamieson. Previous to his connection with the Ordnance Department, General Tripp was chairman of the board of directors of the Westinghouse Electric & Manufacturing Co., at New York.

The assets of the Orenstein-Arthur Koppel Company of Koppel, Pa., were sold by the Alien Property Custodian in an auction at Pittsburgh, on August 12, to W. A. Chamberlain of Pittsburgh, acting for the Pressed Steel Car Company. The price paid was \$1,512,000. Included in this sale were a number of subsidiary companies which were owned by the Koppel company.

Oscar F. Ostby, manager of sales of the Glazier Manufacturing Company of Rochester, N. Y., has been elected vice-president of that company, with headquarters as heretofore at 2736 Grand Central Terminal, New York. He will also continue to represent the Grip Nut Company of Chicago, and the White American Locomotive Sander Company of Roanoke, Va. The Glazier Manufacturing Company manufactures a complete line of oil headlights as well as a complete line of electric headlight cases and interiors. Mr. Ostby, besides having represented the company for about a year, has also been much interested in the locomotive headlight field in the past in the interest of the International Acetylene Association and through his connection with that association, strenuously combated the passage of headlight laws in several states which demanded electrical equipment only. He was born March 5, 1883, and received his education in the public schools of Providence, R. I. From 1901 to November, 1904, he was engaged in publicity work, following which he was connected with the Commercial Acetylene Railway Light &

Signal Company, and later with the Refrigerator, Heater & Ventilator Car Company, serving with the latter as general manager. He has been one of the leading members of the Railway Supply Manufacturers' Association and was its president in 1915-1916.

R. S. Brown, whose election to the position of vice-president of the G. M. Basford Company, was announced in these columns last month, has been with that company since its formation about two years ago. Mr. Brown was born in England, but came to this country in early life. He received his early education in the public schools of East Rutherford, N. J. After completing high school he went to Pratt Institute, Brooklyn, where he was graduated in 1909. On graduation he entered the service of the Erie Railroad as a special apprentice, working successively in the Meadville office of the mechanical engineer, in the Erie shops at Susquehanna, the office of the general mechanical superintendent at New York and the office of the purchasing agent at New York. On the formation of the G. M. Basford Company, Mr. Brown went with the new company as above noted.

E. O. Griffin has been elected vice-president and sales manager of the Rabok Paint Company, with headquarters at Houston, Tex. Mr. Griffin was born at Madison, N. C., on January 3, 1867. He entered railroad service as assistant to the master in chancery on the International & Great Northern in 1889, remaining in the service of that company in various capacities until 1905, when he went with the Missouri Pacific, returning in 1909 to the International & Great Northern. In December, 1916, he was appointed assistant to the president of the St. Louis-Southwestern Lines and on the reorganization of the St. Louis-Southwestern under federal control, he was appointed assistant purchasing agent for that part of the road between Texarkana, Ark., and St. Louis, Mo. In addition to directing the sales work of the Rabok Paint Company at Houston, Tex., he will represent the Southern Railway Supply & Equipment Company, manufacturers of a general line of railway hardware; the Scarritt Car Seat Company; the Harry Benjamin Equipment Company; the Byrnes Belting Company; the Aquart Manufacturing Company, manufacturers of coach cleaning compounds; the Falls Hollow Staybolt Iron Company; the Great Western Smelting & Refining Company; the Royal Waste Company, and Leo Krouse of Texarkana, a manufacturer of hardwood lumber and cross ties.



Guy E. Tripp



R. S. Brown



O. F. Ostby



E. O. Griffin

Railway Mechanical Engineer

Volume 92

November, 1918

No. 11

CONTENTS

EDITORIALS:

Piecework Rates Being Revised.....	589
Journal Box Packing Situation.....	589
Standard Reinforcing for Ends of House Cars.....	590
Pyrometers in Spring Making.....	590
Don't Stop Saving Fuel.....	590
Supervision in the Mechanical Department.....	591
New Books.....	591

COMMUNICATIONS:

Journal Box Packing Situation.....	592
Time Lost in Slowdowns.....	592
Things Fixed.....	592

GENERAL:

Standard Six-Wheel Switcher.....	593
Locomotive Cab and Cab Fittings.....	596
Mechanical Department Supervision.....	597
Superheaters on Rotary Snow Plows.....	598
Conservation in Fuel Oil Boiler Plants.....	599
Virginian 2-10-10-2 Locomotives.....	600
Air Pump Strainer.....	604
Railroad Administration News.....	604
The Proper Location of Locomotive Cab Fittings.....	606
Data for Standard Locomotives.....	607

CAR DEPARTMENT:

Design of Seventy-Ton Coal Car with Tandem Hoppers.....	611
---	-----

Limit of Cost for Freight Car Repairs.....	613
Bad Order Car Situation.....	614
Car Department of the Milwaukee.....	615
Standardizing Painting and Stenciling.....	620
Car Department Orders.....	620

SHOP PRACTICE:

Locomotive Superheater Maintenance.....	621
An Interpretation of the Order Increasing the Wages of Railroad Shop Employees.....	623
Forming Eyebolts on the Bulldozer.....	624
When the "Old Man" Showed His "Pep".....	625
Hand Power Lathes for Rod Packing.....	627
The Difficulties of Welding Steel by the Oxy-Acetylene Welding Process.....	628
Grinding in Locomotive Shops.....	629

NEW DEVICES:

Cincinnati Acme Flat Turret Lathe.....	633
Gold Inside Connected Vapor Valve.....	634
Seamless Hollow Staybolt Iron.....	634

GENERAL NEWS:

Notes.....	635
Meetings and Conventions.....	636
Personal Mention.....	636
Supply Trade Notes.....	638
Catalogues.....	640

TO OUR SUBSCRIBERS

In the interests of the conservation of paper which the War Industries Board is so earnestly requesting, the Railway Mechanical Engineer will print at the end of the year only a sufficient number of indexes of the 1918 volume to meet direct requests from its subscribers. It is requested, therefore, that those desiring indexes to so advise the New York office, 2201 Woolworth Building, on or before December 20. After that date the requisite number of indexes will be printed and mailed to those requesting them.

Piecework Rates Being Revised

We are told on good authority that another revision of the wage scale is to be made to include a system of payment for pieceworkers. When supplement No. 4 was issued any consideration given the pieceworkers under General Order No. 27 was practically nullified. Since supplement No. 4 has gone into effect, however, it has been found that this has materially decreased the output and considerably increased the cost of doing the work. Various roads have estimated a loss in their output anywhere from 25 to 50 per cent. Human nature on the average is such that persons, unless they have an incentive, will do no more than they actually have to do and still hold their positions. This has been found sadly true in the car department of the railroads. The output per man is falling off and the cost of the work is being greatly increased. On one particular road

we have in mind the men are performing about 25 per cent less work and getting from 60 to 70 per cent more money for the work they perform. If economical operation in the mechanical department is to be attained, and if the output is to be held up to the standard of the past, an equitable piecework rate must be established to provide the incentive for the men to work by the piece and not by straight day wages.

Journal Box Packing Situation

In our communications column is a letter from "Mechanical Engineer" asking for information regarding substitutes of wool waste for journal box packing. We welcome this opportunity of serving our readers, and particularly our correspondent, in this respect. Wool waste has become extremely scarce for journal box packing. It is being used successfully in the manufacture of blankets for our boys over seas and perhaps so successfully than even after the war it may be difficult to get the same grades of wool waste for packing as before, except at extremely high prices. The situation now is a serious one, and particularly to those that have had no experience with other than wool waste packing. Some roads are using 50 per cent cotton and 50 per cent wool, and there are other roads using all cotton. In addition to the type C packing mentioned by our correspondent the Railroad Administration's specifications contain two other grades, types A and B. Type A calls for 15 per cent vegetable fibre, 30 per cent shredded wool carpet, five per cent No. 1 domestic merino threads, 40 per cent cotton threads and 10 per cent shredded linsey carpet. The type B packing is made up of

35 per cent shredded wool carpet, 10 per cent No. 1 domestic merino threads, 20 per cent cotton threads, 25 per cent shredded linsey carpet and 10 per cent respun yarn.

It would be extremely interesting and of considerable service to the railroads if those who are successfully using packing that is available would send the *Railway Mechanical Engineer* a brief letter telling of the packing they are using and their experience with it. We invite your assistance.

Standard Reinforcing for Ends of House Cars

Practically every railroad in this country has taken some measures to make old freight cars serviceable under present conditions. This reinforcing has in most cases been confined to the draft members. The draft gear is undoubtedly the principal source of trouble but the old wooden house cars have at least one other point which must be strengthened if the reinforcing is to attain its object of keeping the car off the repair track. The part we refer to is the end. The long trains which are now hauled result in severe shocks in starting and stopping. Ends that were satisfactory when the motive power was light and the draft gear of a type that made careful train handling necessary are not able to meet the requirements of present day service. The foreman of the car department of a prominent road stated recently that a check of the repair bills showed that some cars had the ends knocked out three or four times in the course of a year. This no doubt represents an extreme case, but certainly it is false economy to equip a car with heavy draft members and leave unchanged a weak end construction that will require frequent repairs.

Half way measures for strengthening car ends are practically worthless. There is a growing tendency to apply heavy end lining in old wooden cars. While the added stiffness that is secured does assist in distributing the stresses it does not strengthen the posts to any appreciable extent and does not prevent their breaking or pulling out of the sockets. What is needed is a steel end or metal end post firmly fastened to the end sill and substantially braced at the top. Such construction will do much to eliminate a source of trouble second only in magnitude to short draft timbers. The Railroad Administration has specified the methods to be used in reinforcing draft rigging. Now it might be well to go a step farther and design an approved type of end reinforcing allowing sufficient latitude in the specifications to permit of its being applied on any repair track where the necessary facilities are available.

Pyrometers in Spring Making

The breakage of locomotive springs seems to be causing an unusual amount of trouble at the present time. There is a tendency on some roads to lay the failures to poor material or bad track without attempting to determine the cause. It is true that the spring steel furnished at this time may be of inferior quality, but it is improbable that this is the sole cause of the trouble. One road investigating the breakage of springs found that springs rebuilt in the company's shops failed much more quickly than springs received from the manufacturer, which of course indicated that the rebuilding was not being done properly.

There are no doubt many shops where an investigation of the methods of making springs would disclose numerous opportunities for improvement. The tempering of spring steel is an operation requiring great care. Most railroad spring plants are crude affairs and it is difficult to secure the exact degree of heat required for the quenching operation. Some of the furnaces used for tempering springs do not give an even heat and as a result the springs do not have a uniform hardness. The operation of drawing the temper requires even closer control of the heat than hardening. It is essential that the furnace give a uniform temperature and

that the blacksmith should be able to determine when the leaves are heated to the proper point in order that the steel when annealed may have the required structure to give it strength and resiliency without brittleness.

As long as the judgment of the blacksmith is relied upon to determine when springs have reached the proper temperature the results are sure to vary. Lead or salt baths for heating the leaves prior to hardening and for drawing the temper are in use on some roads and have given excellent results. Pyrometers are used in both baths so the entire process can be regulated to make the springs uniform and of the exact degree of hardness required. There is one difficulty with this method that has not yet been overcome. The pyrometers require frequent checking to insure accuracy as no type has yet been found that can be depended on to maintain the original setting in this service. This is a minor matter, however, compared with the benefit derived from accurate heat treating. In one case it was found that the service life of locomotive springs was increased 50 per cent by the use of the pyrometer in tempering. The saving of work in the spring shop is a large item but there is a further economy due to the reduction in the labor incident to applying springs to replace those broken in service.

Don't Stop Saving Fuel

So much has been said about saving fuel in past years and the subject so vigorously agitated during the present year that it may seem to some to be an old story. It is an old story, but one which becomes increasingly important. At this particular time each day brings its demand for still greater economy in the use of fuel. It is one of the controlling elements in the life of the nation and particularly in the part this nation is to play in the war and the reconstruction after the war. If those men, if there are any and we hope there are none, who are sick and tired of being preached to on the subject of fuel economy, would again view the situation in its true perspective and consider that our industrialists will need 18 per cent more coal than was used last year, our railroads seven per cent more, our steamships 30 per cent more, our gas and electric light plants 15 per cent more, and that the gross requirements for the whole nation will demand an increase of between 14 and 15 per cent of the output in 1917, they will take off their coats and put into practice the many things they have been taught will save fuel. As F. P. Roesch, fuel supervisor in the Northwestern region, stated in a paper before the Missabe Railway Club, it isn't the value of the fuel that we are trying to save—it is the fuel itself. Regardless of money it is impossible to increase the supply to meet the required needs. Economy is the only solution. We do not fully realize this on account of the fact that the government has fixed the price of coal with disregard to the supply and demand. There is hardly a person in the country but can contribute either by practicing economy themselves or urging others to do so. Everybody who handles any quantity of coal must be made to appreciate the situation. Everybody must do his best to conserve the power and heat produced by the coal. Don't waste lights, keep the office temperature down to a livable degree. Turn off the heat when the rooms get too warm. Stop the little leaks that are in the steam, air or water lines. Conserve the heat by insulating exposed surfaces. Revise the locomotive front end arrangement to suit the coal being burned in the firebox. Be sure that the arch is intact so that the fuel may be properly burned, and that the flues are clean, in order that the boiler may absorb all the heat possible. Do the many other things which you know will save fuel and don't ask yourself why somebody else doesn't do it, but do it yourself. Bring everybody about you to a full realization of the true fuel conditions. Make them appreciate how serious the situation is and set them a good example to follow.

**Supervision in
the Mechanical
Department**

Frank McManamy's paper before the New York Railroad Club on October 18 discloses a keen perception of the fundamentals of effective supervision and the vital part which supervision must play in the success with which the mechanical department shall meet the heavy burden of responsibility now placed upon it. The war has effected a general dislocation of the supply of both labor and material, requiring a more effective employment of the former and a smaller expenditure of the latter than has ever before been demanded of the maintenance organizations of our railroads. For an appreciable improvement in either respect we must look almost wholly to the supervision. It is unfortunate that a clearer appreciation of this fact has not sooner and more generally been manifested by the Railroad Administration.

The labor forces in the mechanical department have been dealt with liberally by any standard of comparison which may be chosen and of this, in principle, we hardly think there is a railroad man or a citizen who will not approve. The fact must be admitted, however, that the result has not been that increase in morale, that increase in the effort of the individual, so sorely needed in the present situation. Rather the opposite tendency has been observed. It is inconceivable that this is attributable to a lack of patriotism among railway mechanics. Railway men certainly average no lower, and probably no higher, in patriotism than any other equal group of citizens. But patriotism cannot be bought and patriotism alone can accomplish little without proper organization. Indeed, the present situation must be accounted for by a failure to observe some of the fundamental principles of successful organization rather than by questioning the motives of individuals, either in the ranks or in positions of responsibility.

A casting up of the situation in the light of the principles so clearly stated by Mr. McManamy may offer some constructive suggestions. These, in effect, are as follows:

1. Supervision to be effective must be adequate in quantity.
2. Supervision to be effective must be constant.
3. Supervision to be effective must be respected.
4. Supervision to be effective must be instructive.
5. Supervision to be effective must be courageous.

The first two principles have never been adequately observed by the railroads. There are few shops in which the number of foremen has been adequate, or in which these men have not been burdened with duties which properly do not belong to them. This is a condition inherited by the Railroad Administration, which offers the opportunity to render a real and permanent service to the mechanical department.

The action of the Railroad Administration leaves much to be desired on the third point. The respect accorded supervision depends upon many things—personality, authority and by no means least of all, the respect accorded by the management of the railroads to the supervising officers. In the wage increases and readjustments which have been effected, failure to give adequate consideration to the supervision has served to aggravate an already undesirable situation and undoubtedly has tended to lower the respect of the men for the supervising officers with whom they come directly in contact. The only standard by which the relative value of the men in the ranks and the supervising officers, charged with the full responsibility of securing output, may be estimated is earning capacity. The morale of no organization can be at its highest when relatively so little respect is accorded its supervising officers as is implied by the present relation between wages and salaries and by the large amount of public attention which has been given to the question of wages, with almost utter silence as to the claims of the supervision.

The instructive phase of supervision has never been given

adequate attention by the railroads, a fact to which we have frequently called attention. One of the best means of fulfilling this requirement, especially with the dilution of labor skilled in the requirements of railroad work necessary at the present time, is the employment of instructors, whose duties are to supervise the methods employed in the performance of the various tasks in the shops.

The highest type of courage cannot be exercised by the minor supervisory officers when any of the normal relationships within the organization are out of joint. Courage, while primarily a personal quality, is seriously handicapped in its proper expression by a lack of esprit de corps.

There are two things which need to be done to secure adequate, constant, respected, instructive and courageous supervision: (1) Pay—pay what it is worth and pay for enough of it; (2) accord it the same encouragement and public recognition that has so lavishly been given to labor. These are as much demanded by justice as they are highly essential to the success of the motive power department organization.

NEW BOOKS

Modern Locomotive Valves and Valve Gears. By Charles L. McShane, 330 pages, illustrated, 5½ in. by 7½ in., bound in cloth. Published by Griffin & Winters, New York Life building, Chicago. Price \$2.50.

In order that this subject may be thoroughly understood by all persons seeking information regarding locomotive valves and valve gears, regardless of their previous training, this book includes a chapter covering the general definitions and technical terms used in connection with the subject. This is of particular advantage as it brings under one cover this important matter and a thorough discussion of the different types of valves. The action of the various types of valves is discussed very fully, which with numerous and particularly clear illustrations enable the reader to get a very clear conception of the operation of the various valve gears in general use, including the Walschaert with various modifications, the Baker valve gear, the Southern valve gear and the Young valve gear. Particularly full discussion is given to the Walschaert gear and in every case methods of setting these gears is given. The subject matter is written in a clear, understandable manner, every effort being made to keep away from the complex technicalities that are usually introduced in the discussion of the subject.

Eye Hazards in Industrial Occupations. By Gordon L. Berry, 145 pages, illustrated, 6 in. by 9 in., bound in cloth. Published by the National Committee for the Prevention of Blindness, 130 East Twenty-second street, New York. Price 50 cents.

In the United States there occur every year nearly 200,000 eye accidents, and about 15,000 people in this country are blind to-day as a result of injuries received in industrial occupations. The importance of the prevention of eye accidents to workers can be judged from the fact that they make up nearly 10 per cent of the total casualties reported. Practically all the major causes of injuries to eyes are present in railroad shops. These include machine operations, chipping and grinding operations, babbitting, sand blasting, riveting, using "mushroomed" tools, autogenous welding, spraying processes and using acids and chemicals. There is also danger of injury to the eyes from radiation from intense light and heat, from fumes, vapor and gases and from bursting gage glasses.

This book is the most complete compilation of material relating solely to the prevention of eye accidents, that has been published. Studies of the causes of eye accidents and the methods used to prevent them have been made in a large number of plants. Under each subject treated an account is given of the preventive measures which have been successfully used, and numerous illustrations help to make the descriptions clear.

COMMUNICATIONS

JOURNAL BOX PACKING SITUATION

CHICAGO, ILL.

TO THE EDITOR:

One of the greatest difficulties we are having to contend with in the car department at the present time is that of obtaining a suitable journal box packing. In the past our road has used long wool waste because of its resiliency and excellent capillary action, but this has been denied us and from lack of experience with other packing we are anxious to learn of a good substitute. At the present time we are using the C mixture specified in the United States Railroad Administration's specification No. R-94. This consists of 15 per cent vegetable fibre, 40 per cent cotton threads and 45 per cent wool threads. We have not had this in service long enough to determine exactly what results we will obtain from it. We have hesitated to use all cotton waste, although we understand that there are several roads which do. Believing that there are others of your readers who have had to contend with the same situation, your paper could undoubtedly be of valuable assistance to all the railroads if a thorough discussion of this subject were given in your columns.

MECHANICAL ENGINEER.

TIME LOST IN SLOWDOWNS

NEW YORK CITY.

TO THE EDITOR:

Having read with much interest the article on Time Lost in Slowdowns by Walter V. Turner, Eng. D., appearing in the September issue of the *Railway Mechanical Engineer*, I beg to offer a few remarks pertinent to the broad and general principles of the subject under discussion.

It is true that much time is lost by trains which in passing through populous communities are subject to local regulations governing the matter of speed. However, much delay is also caused by improper arrangement of schedules. Years ago a prominent terminal used a system which should have been perpetuated, as it was simple and eminently just. If a number of trains were due to leave in a short space of time, the most important one left first and the others followed in the order to which their standing entitled them. The big "limited" had a clear track and was out of the way before the next train came along, and thus an orderly procession was the result. Later on this arrangement was abolished and I have seen the most famous train in this country held up and brought to a full stop less than a mile from its starting point by a "penny-aute three-car local." Changes in this terminal have made observation of its operation difficult, and in any case its enlarged facilities may have improved matters. Be that as it may, there is still room for improvement in various parts of the country today and insignificant locals should not be permitted to "lay out" a road.

For a long time uninformed sections of the public imagined that fast trains were patronized exclusively by gilded "joy-riders." It is now being brought home to these people that the biggest men of the country, engaged in business of vital importance, find these trains a convenience and a necessity. Those who recall the "Exposition Flyer" of 1893 will remember that this 20-hour train between New York and Chicago was not patronized so much by visitors to the Fair as by bustling business men who recognized it as a public convenience and time saver.

Mr. Turner deserves a vote of thanks for directing attention to a subject of timely interest and practical value. Even those who are not sufficiently advanced to understand

all of his figures will derive benefit and profit from a study of those aspects of the subject which they can comprehend, and will be encouraged thereby to familiarize themselves with the problems to which Mr. Turner refers.

ARTHUR CURRAN.

THINGS FIXED

LOUISVILLE, Ky.

TO THE EDITOR:

Concerning that word "Standard" about which we have had something to say.

We are now about to enter into a phase or cycle of standardization which needs to be keenly observed by every thoughtful mechanical man; laying aside all prejudice let us view the experiment broadly and with unbiased minds.

For the time being every pet idea must be relegated to the background and those things which we have harlored for the most of our lives, we are to forget for the present. Fall into line is the command and do with what has been allocated to our territory as if every detail were part and parcel of our own inventive genius. This is what our government has in effect requested and commanded and as good citizens and soldiers it is ours to obey to the letter and in the fullest spirit to which we assent. In order that nothing escape our attention, however, we note in passing that first of all we must make new patterns for these new locomotives, carry a new stock of gray iron and cast steel parts, a new line of fittings such as checks, water gages, steam valves, turrets, pops, gages, etc., etc., etc. We also note that our reamers, taps, milling cutters and dies are not suitable—nor have we jigs or templates suitable for renewals and repairs. All of which is merely by the way, inasmuch as we are preparing to lay in our stock accordingly so as to have everything in readiness for the next lot of new power.

Now the question is shall we accept these machines as they are without a comment or suggestion? Who is to guide the future design from the pitfalls to which every designer is a victim now and then? How long are these splendid engines to remain as they are? By whose authority are we to assume they will be the 1919 Model Mikado? Who is to follow up their daily performance and what is to be done if some detail is found to be impractical? Shall we keep to the design, literally renewing those parts which fail, just exactly as they were before they break, or shall we do as we have done heretofore and strengthen the weaknesses as they occur, keeping a memorandum of the various changes to be made in the next design in order to meet the conditions with which we are confronted on our various divisions. Common sense tells us that we are to face these questions and do the things as we have always done them. Locomotive designing is not yet finished; we must go on and on to perfection, suggesting, experimenting, changing until the highest art is reached and reached again.

Who will then gainsay this plain simple reasoning. Does it not argue into the thinness of air the delusion of permanent design or THINGS FIXED.

MILLARD F. COX, M.E.

FOURTH LIBERTY LOAN RETURNS.—It is estimated that the railroads have subscribed 75 per cent over the amount taken in the Third Liberty Loan. Complete returns have been received from three regions. In the Eastern region 12 out of 48 roads were 100 per cent, in the Central Western region 21 out of 42 roads were 100 per cent and in the Northwestern region 23 out of 38 roads were 100 per cent. In the Eastern region 90 per cent of the employees in the mechanical department subscribed and in the Northwestern region 99.33 per cent subscribed. The average subscription per subscriber was \$102 in the Eastern region, \$117.14 in the Central Western region and \$112.12 in the Northwestern region.



STANDARD SIX-WHEEL SWITCHER

Fourth Design of the Government's Standard Locomotives
to Be Built—Fourteen to Go to the Chicago Junction

DURING the month the fourth type of the government's standard locomotives was built by the American Locomotive Company at its Cooke Works. Fourteen of these locomotives are to be delivered to the Chicago Junction Railway and later twenty will go to the Pennsylvania Lines West and five to the Atlantic Coast Line. These locomotives weigh 165,000 lb. in working order; 55,000 lb. being carried on each axle, and they have 21-in. by 28-in. cylinders with 51-in. drivers. These engines have many details in common with the standard 0-8-0 locomotives which were described in the *Railway Mechanical Engineer* for October on page 543. They are also a great deal like the Six-wheel switchers built for the Chicago & North Western by the American Locomotive Company a few years ago, the cylinders, drivers and fireboxes being practically of the same dimensions and the boiler is of the same design with only about a difference of 100 sq. ft. in the total evaporating heating surface and 40 sq. ft. in the superheating surface. The Chicago & North Western engines have given excellent service in both transfer and switching work. These engines are used to transfer freight between the Fortieth avenue and Proviso yards in Chicago, a distance of about nine miles. They have handled 3,000 tons over grades of 0.92 per cent and 0.8 per cent.

The boiler of the standard 0-6-0 switcher is of the same general design as that of the Eight-wheel switcher. It was designed for a pressure of 200 lb. but has a working pressure of 190 lb. It is 66 in. in diameter, of the straight telescopic type, with 19 52-in. barrel sheets, 9/16-in. front tube sheet and 1/2-in. back tube sheet. There are 158 two-inch tubes and twenty-four 5 1/2-in. flues, 15 ft. long over tube sheets. The size and length of the tubes are the same as those in the Eight-wheel switcher. The firebox is 72 1/4 in. long by 66 1/4 in. wide. The door and crown sheets are 3/8 in. thick and the wrapper sheet and back head are 9/16 in. and 1/2 in. thick, respectively. The water legs are 5 in. wide at the throat and 4 1/2 in. wide on the other three sides. There are three tubes for a Security brick arch and the O'Connor fire-door flange is used. There are 346 flexible, 58 hollow and 83 solid staybolts. The boiler is equipped with a 24-unit type A superheater having a heating surface of 442 sq. ft., which with an evaporating surface of 1,886 sq. ft. gives an equivalent heating surface of 2,536 sq. ft.

The general design of the frame for these engines is the

same as for the 0-8-0 standard locomotives. These frames are 5 in. wide from the front to just back of the rear set of drivers, where a slab section 2 in. wide by 12 in. deep, increasing to 3 in. wide by 18 in. deep at the extreme end is provided. They are 5 in. deep over pedestals and 4 1/8 in. deep at the smallest section of the upper rail. The lower rail is 3 in. deep. A heavier section is provided under the cylinders, the depth of the frame being increased to 7 3/8 in. and to 9 1/2 in. at the buffer beam. The pedestal binders have a minimum section of 3 in. by 5 in.

The side rods are of slab section, the front rod being 5 in. by 1 1/2 in. and the back rod 4 in. by 1 5/16 in. These are coupled together with a 4-in. knuckle pin. The connecting rods are of channel section, being 6 in. deep with 7/8-in. flanges 3 1/4 in. wide, and 5/8-in. webs. A cast iron box type piston is used, having Hunt-Spiller bull and packing rings. The piston rod is 3 3/4 in. in diameter. The crosshead is of the alligator type, having Hunt-Spiller gun iron shoe. The steam distribution is controlled by the Baker valve gear, which in general is of a design similar to that used on the 0-8-0 switchers, many parts of which are duplicates. Both the Lewis and Mellin reverse gears will be used on locomotives in this order. The packing of both the valves and cylinders is of the United States Metallic Packing Company's design.

The piston valves are 10 in. in diameter and are fitted with bushings and packing and bull rings of Hunt-Spiller gun iron. The cylinder bushings are also made of the same material.

The tender is identical with that used with the 0-8-0 switchers, having a capacity of 8,000 gal. of water and 16 tons of coal. The tank has the Locomotive Stoker Company's type D coal pusher, Commonwealth cast steel underframe, and cast steel tender truck side frames to be furnished by the American Steel Foundries and the Buckeye Steel Castings Company. The tender wheels are cast iron, being 33 in. in diameter.

There are a large number of details on this locomotive that are common to the standard Eight-wheel switcher and a few common to all of the standard locomotives. Among the items common to both of the switchers may be mentioned driving axles, driving boxes, shoes and wedges, pedestal crossies, grates, tube setting, coal pusher, many of the cab fixtures,

bumper arrangement, bell details, reverse shaft yoke and bell crank. Such details as the dome cap, coupler, coupler draw-head, eccentric rod bearings, cylinder cocks and gage cocks are common to all of the standard locomotives.

These engines are to be equipped with the Shoemaker fire-

Chicago & North Western by the American Locomotive Company a few years ago:

General Data

	U. S. R. A. Standard	Chicago & North Western
Gage	4 ft. 8 1/2 in.	4 ft. 8 1/2 in.
Service	Switching	Transfer
Fuel	Bit. coal	Bit. coal
Tractive effort	39,100 lb.	37,000 lb.
Weight in working order	165,000 lb.	171,000 lb.
Weight on drivers	165,000 lb.	171,000 lb.
Weight of engine and tender in working order	309,000 lb.	298,000 lb.
Wheel base, driving	11 ft.	11 ft. 6 in.
Wheel base, total	11 ft.	11 ft. 6 in.
Wheel base, engine and tender	49 ft. 3 1/2 in.	47 ft. 6 3/4 in.

Ratios

	U. S. R. A. Standard	Chicago & North Western
Weight on drivers ÷ tractive effort	4.22	4.62
Total weight ÷ tractive effort	4.22	4.62
Tractive effort × diam. drivers ÷ equivalent heating surface*	782	732
Equivalent heating surface* ÷ grate area	77.3	78.9
Firebox heating surface ÷ equivalent heating surface* per cent.	5.41	5.89
Weight on drivers ÷ equivalent heating surface*	64.7	66.28
Total weight ÷ equivalent heating surface*	64.7	66.28
Volume both cylinders	11.22 cu. ft.	11.22 cu. ft.
Equivalent heating surface* ÷ vol. cylinders	226.5	229.8
Grate area ÷ vol. cylinders	2.94	2.96

Cylinders

Kind	Simple	Simple
Diameter and stroke	21 in. by 28 in.	21 in. by 28 in.

Valves

Kind	Piston	Piston
Diameter	10 in.	12 in.
Greatest travel	6 in.	6 1/2 in.
Outside lap	3/8 in.	1 in.
Inside clearance	0 in.	0 in.
Lead in full gear	1/8 in.	3/8 in.

Wheels

Driving, diameter over tires	51 in.	51 in.
Driving, thickness of tires	3 1/2 in.	3 1/2 in.
Driving journals, main, diameter and length	9 in. by 12 in.	9 1/2 in. by 12 in.
Driving journals, others, diameter and length	9 in. by 12 in.	9 1/2 in. by 12 in.

Boiler

	Straight	Straight
Working pressure	190 lb. per sq. in.	180 lb. per sq. in.
Outside diameter of first ring	66 in.	66 in.
Firebox, length and width	72 1/2 in. by 66 1/4 in.	72 3/4 in. by 65 1/4 in.
Firebox plates, thickness	1/2 in. and 3/8 in.	3/8 in.
Tubes, number and outside diameter	158—2 in.	160—2 in.
Flues, number and outside diameter	24—5 1/2 in.	22—5 3/4 in.
Tubes and flues, length	15 ft.	16 ft.
Heating surface, tubes	1,233 sq. ft.	1,333 sq. ft.

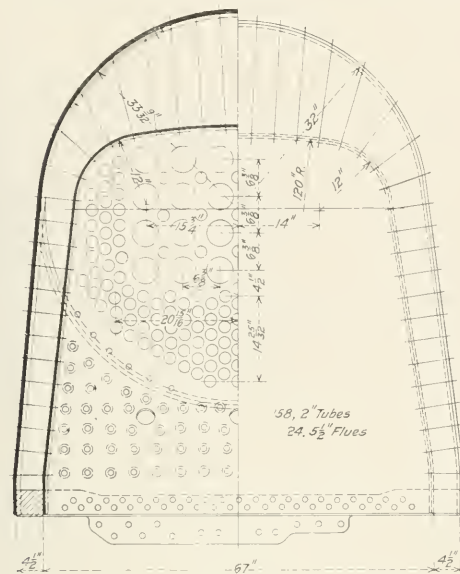

Sections Through Six-Wheel Switch Locomotive

door, Cole safety valve, Sargent safety three-face water gage, No. 11 non-lifting Nathan injector, Detroit three-feed lubricator, Pyle electric headlight, Westinghouse air brakes, Imperial type B uncoupling device, unit drawbar, Franklin flexible metallic joints, Ashcroft steam gages, Chicago Railway Equipment Company brake beams, Woods tender side

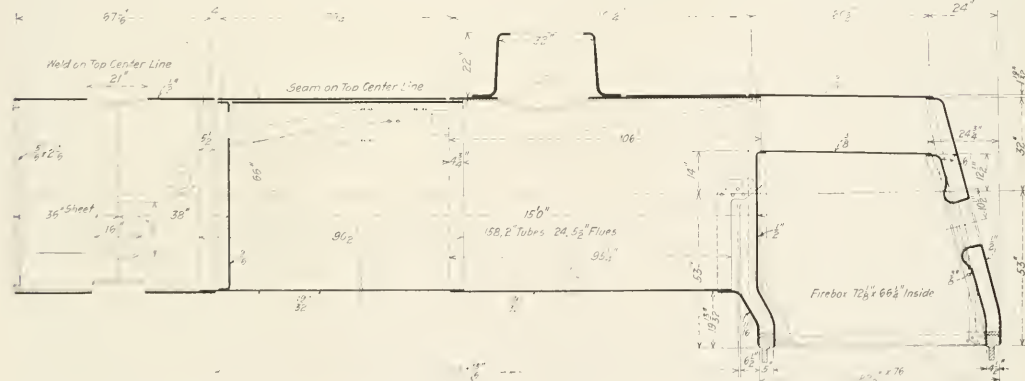

Boiler for the Standard Six-Wheel Switcher

bearings, Westinghouse type D-3 draft gear, Hancock sprinkler, Chambers throttle and United States Metallic Packing Company pneumatic sanders.

The following table contains the principal data and dimensions of these engines as compared with those built for the

Heating surface, flues	515 sq. ft.	492 sq. ft.
Heating surface, firebox	138 sq. ft.	152 sq. ft.
Heating surface, total	1,886 sq. ft.	1,977 sq. ft.
Superheater heating surface	442 sq. ft.	402 sq. ft.
Equivalent heating surface*	2,549 sq. ft.	2,580 sq. ft.
Grate area	33 sq. ft.	32.7 sq. ft.
Smokestack, height above rail	14 ft. 1/2 in.	14 ft. 5 3/4 in.
Center of boiler above rail	102 in.	103 in.

	Tender	
Tank	Waste bottom	Water bottom
Frame	Commonwealth	Cast steel
Weight	144,000 lb.	127,000 lb.
Wheels, diameter	33 in.	33 in.
Journals, diameter and length	6 in. by 11 in.	5 in. by 9 in.
Water capacity	8,000 gal.	6,500 gal.
Coal capacity	16 tons	10 tons

*Equivalent heating surface of total evaporator heating surface + 1.5 times the superheating surface

LOCOMOTIVE CAB AND CAB FITTINGS*

The many types of engines make a universal design of cab hardly feasible, but it is felt that the following suggestions could be adapted to any design of locomotive cab:

Body of Cab.—The overhang of a cab should be of dimensions such as will insure protection from the elements to the fireman. This really necessitates its extension to a point approximately over the coal doors on the tender.

It is the opinion of the committee that the front windows of the cab should be as close as consistent to the engine crew's usual and proper position in the cab. This is to provide a broader view for the engine crew.

The side windows provided for locomotive cabs are as a general rule of the sliding type, and we believe that a sash should be constructed in such a manner as to provide for small panes of glass, for the reason that the portion of frame between window panes forms a brace lessening the liability of breakage, and in case of breakage it reduces the cost of replacing, and lessens the opening while in service.

Ventilators should be provided and so constructed as to exclude cinders.

Gutters on sides of cab should be located immediately over the windows in such a way as to afford all of the protection possible to the engine crew. The opinion of the engineman is that it should be immediately over the cab window.

Cab Fittings.—Receptacles should be provided for signal appliances, such as lanterns, fuseses, flags, torpedoes, etc. Torches, oil cans, hand tools, shaker bars, broom and other portable cab equipment should have convenient receptacles or hangers provided so that they may readily be located by the engine crews.

Boiler Appurtenances.—The steam manifold has been given various locations. Some are inside of the cab directly on top of the boiler, and where two are used they are usually located in the cab on the sides of the boiler near the top. Those located outside of the cab are just forward of the cab on top of the boiler and are provided with rods that extend through the front of cab for the purpose of operating the steam valves on the steam turret. This last mentioned arrangement, that is outside of the cab, has numerous advantages over those located inside. It produces a cooler cab in warm weather and a drier cab in the cold season; it lessens the number of steam pipes in the cab and correspondingly decreases in number the pipe holes in cab that are generally hard to seal and keep tight against severe weather.

It is believed that better provisions could be made for the securing of the injector to the boiler. It is suggested that it be provided with a bolting flange similar in a way to the bolting flange on an air pump with a bed plate on the boiler. In cases where injectors are located outside of the cabs substantial rods equipped with durable joints and suitable brackets that will keep the rod from turning and thereby change the capacity at times when it should remain constant, should be provided. The operating handles should be located conveniently within reach of the engine crew.

There is no question but that the "Bull's Eye" type of lubricators is most desirable, but the manner in which they are secured deserves greater attention.

Throttle and Reverse Lever.—It is desirable to have the throttle lever so located that it can be readily handled by the

engineer and at the same time have his head outside of the window to observe signals from either front or rear.

Where a power reverse gear is used an indicator should be provided to indicate the position of the valve gear. When air reverse gear is used, the steam connection globe valve should be located within handy reach of the engineman in the cab, so that the steam pressure may be readily turned on in case of an air failure.

Brake Valves.—Automatic and independent air brake valves in cabs should be located in a manner to provide ample clearance with the handles in any position and so they may be easily operated from the engineman's usual position.

The report was signed by: J. H. DeSalis, chairman; W. H. Corbett, W. W. Shelton, H. H. Schulte and H. F. Henson.

DISCUSSION ON CAB FITTINGS

John McManamy, supervisor of equipment, U. S. R. A., outlined the arrangement of the cabs of the government standard locomotives in which many of the suggestions made in the paper had been carried out. He spoke particularly of the desirability of having all valves and steam pipes outside the cab. The government standard locomotives are equipped with two water glasses as a special safety provision. Care has been taken to prevent interference between the devices in the cab and all handles have a clearance of 3½ in. from adjacent parts in every position.

F. P. Roesch, fuel supervisor, U. S. R. A., commented on the inconvenient arrangement of valves found on many locomotives. Oftentimes the valves can only be packed from the top of the cab and consequently there is an excessive leakage of steam. Mr. Roesch advocated taking out of the cab everything that could conveniently be located elsewhere. He suggested that the steam manifold might well be set against the back of the dome where there was no chance of it being damaged in case of collisions or accidents.

G. A. Kell, Grand Trunk, told of the complaints received from enginemen when the vestibule cabs were first installed. The men objected to them on the grounds that they were noisy, cold and dirty. By greasing the buffers the noise was largely reduced and a dust-board on the roof assisted in keeping out the dirt. In order to keep the cab warm about 10 in. of lagging was removed from the boiler just above the floor of the cab.

A. N. Wilsie, C. B. & Q., spoke of the importance of locating the feed valve in a convenient position in the cab and also mentioned the good results that had been secured by placing a centrifugal dirt collector in the delivery pipe near the main reservoir.

L. D. Gillett, Dominion Railway Commission of Canada, endorsed the vestibule type of cab as the best thing for protecting the enginemen and insuring comfort under all weather conditions. He stated that the vestibule cab if properly designed and maintained was comfortable both in the hot and cold weather.

J. C. Petty, N. C. & St. L., stated that it was found necessary to remove the vestibule cabs from the Russian locomotives operated in this country. He stated that the failure of this type of cab might have been due to the fact that they were built of sheet steel but were not lined.

F. Zwright, Nor. Pac., spoke of the failure of the clear vision cab window in cold climates. After the windows were installed, as required by law, so many objections were received from the enginemen that it was found necessary to return to the use of a double glass with a dead air space between. Several members spoke of the desirability of shortening the cab to bring the front window nearer to the enginemen and give them a broader angle of vision.

J. H. DeSalis, N. Y. C., in closing the paper stated that while there were many changes in cabs which would add to the comfort of the enginemen, it was impossible to bring these changes about quickly in the present circumstances.

*Abstract of a committee report presented at the 1918 convention of the Tri-State Engineers' Association.

MECHANICAL DEPARTMENT SUPERVISION*

Better Supervision and More of It Is Needed to Keep Up Shop Output Because of Dilution of Labor

BY FRANK McMANAMY,
Assistant Director, Division of Operation, United States Railroad Administration

THE importance or in fact the necessity of efficiency in the railroad organization cannot be overestimated and, as stated by the director general in his report to the President, the efficiency of the railroads depends entirely upon the supply and condition of the motive power and the efficiency with which it is operated. The important question, therefore, is to get the locomotives in shape to perform efficient service and maintain them in that condition. At the present time the big factor in this is the question of supervision of shops and shop work.

Reports show that there are employed in the mechanical department of the railroads under Federal control, 393,000 persons, of whom 255,000 are in the locomotive department and 138,000 in the car department. To insure efficient and economical handling of this labor and material, organization is required and the prime factor in any organization is supervision. Railroad forces, and particularly maintenance of equipment forces, have been subjected to heavy drain because of the war and this has resulted in dilution of the quality of labor. Because of this dilution supervision both in kind and in quantity, becomes even more important than heretofore. It is to-day the big problem in railroad operation.

Supervision to be effective must be adequate in quantity, therefore, the number of workmen under one officer must be such that the officer is in constant touch with his force. Persons who have studied military and industrial organizations state that one man can properly supervise not to exceed from 25 to 35 men, a figure much below that which is often used in railroad work which has been known to extend to nearly 100 men. The statements as to the number of men who can be properly supervised by one officer are based on studies made when conditions were normal. In view of the necessity for the intensive use of labor and material to-day, because of the demand for both, the figures stated are, I believe, too high.

Supervision to be effective must be constant. The withdrawal of the foreman or supervising officer from his duties many times each day to answer summons from those in authority, the preparation of reports and routine office work which could be done in much less time by persons with clerical experience, the daily attendance to staff meetings which necessitates absence from usual duties for periods ranging from 30 minutes to two hours, are not conducive to efficient supervision.

Many supervisory positions have been permitted to become supervisory positions in name only. We find superintendents of shops, master mechanics, general foremen, roundhouse foremen and even men in positions of lesser responsibility, required to devote so much time to office work, to personally transmitting reports to superiors and to other work of like character, that they can devote little or no time to the direction of the active work, and by active work I mean the actual expenditure of the labor and material under their control.

Supervision to be effective must be respected, and this applies to those of higher as well as lower rank. The possession of proper title to indicate the character of services rendered which will command respect from those under his jurisdiction and consideration from those in other departments with whom he comes in contact, is a necessary advantage which should be given each supervising officer.

Active competition for supervisory positions should be encouraged by making such positions as attractive as possible and if this is done, it will result in securing the best material available, which is highly essential if the output in both grade and in quantity is to be kept up to the standard.

Supervision to be effective must be instructive. Some one has said that the principal reason for not getting the result we anticipated was because we failed to explain just what was wanted—a lack of understanding. To this cause may be laid many failures both of men and of plans. It is necessary, therefore, that instructions be complete, that they be concise, that they be understandable, and that—above all, they be workable.

The issuance of orders is the easiest thing in the world, but to issue a large number of orders is to insure their being disregarded. Voluminous instructions therefore should be carefully avoided. If this is done and the instructions issued are brief and are to the point, better observance may be expected; instructions alone, no matter how carefully prepared, are of little value without a proper follow-up or checking system to see that the instructions are observed and the work up to the required standard.

Supervision to be effective must be courageous. The quality of production comes from the top downward. We get from the average workman as good a job as we accept, no better. Supervision must maintain the accepted standards and this requires, in many cases, real courage, but it is necessary, and the supervising officer is the only means whereby this can be accomplished. With the conditions now existing the maintenance of high standards is necessary to the morale of the forces and to the preservation of proper discipline.

There are approximately 20,000 more employees in the locomotive department to-day than there were a year ago and approximately 8,000 more in the car department than for this date last year. Added to this we are working more hours, many more hours, per week than we did a year ago. With the increase in force and the increase in man hours, we are not in all cases receiving the returns we should; I attribute this largely to inefficient supervision.

I have endeavored to point out some of the essential requirements of effective supervision but it must be more—it must be responsible, as authority and responsibility go hand in hand. We cannot separate them and if we confer adequate authority on an officer he must have sufficient confidence in his own ability and judgment to do the work required and assume the responsibility for it.

Since the government has assumed control of the railroads supervising officers have often made the statement that they did not know just what authority they had and in many instances when matters which have always been handled by certain officials have been put up to them their reply has been "I do not know whether I can handle this without instructions from Washington," and this has been given as an excuse for failure of almost all kinds.

Paragraph 1 of General Order No. 1, issued by the director general on December 29, 1917, reads as follows:

All officers, agents and employees of such transportation systems may continue in the performance of their present regular duties, reporting to the same officers as heretofore and on the same terms of employment.

This in the absence of subsequent orders to the contrary, seems to me effectually to dispose of any doubt as to the

* Abstract of a paper presented before the New York Railroad Club.

authority of supervising officers and leaves the question of failure to properly supervise the work squarely up to the officer involved. What is wanted by the Railroad Administration is that each railroad officer or employee who remains in the service, who continues to perform the usual duties assigned to him will if possible do a little more work than he ever did before and do it a little better.

There can be no question as to the authority of railroad officers under government control to perform all of their usual duties and there has been no lack of support from the Railroad Administration when those duties were properly and diligently performed.

A discussion of the question of supervision would not be complete without considering co-operation in connection therewith, because I believe the real test of the supervising officer is his ability to obtain the co-operation of the men working under his direction. The extent to which the supervising officer can get his force to work together for a common object depends almost entirely upon his attitude toward the men and his interest in the work that is being done. The supervising officer who considers that his full duty has been performed when he has issued instructions covering the work to be done is not going to secure any great amount of co-operation. He must show the employee that he has a personal interest not only in the work but in the workman. They must know that in addition to passing out the work slips he is going to follow them to see that the work is promptly done and in a workmanlike manner. He should also encourage workmen by seeing that both material and tools are supplied to mechanics so that they may keep their machines in operation, for there is no one thing that goes further to discourage a good mechanic and curtail the output than to require him to shut down his machine while locating materials which should have been delivered by a laborer or to secure tools which a tool messenger should have delivered.

There is nothing that will keep a force of men at their best quite so well as the knowledge that the supervising officer is on the job, inspecting their work, both as to quality and quantity, and that good work will be noted and the workman given due credit, as surely as work that is not up to the standard will be corrected.

In addition to co-operation between employees and supervising officers we must also have co-operation between different departments if we are to get results out of our locomotive shops. The work must be co-ordinated so that time lost by one department in waiting for another is reduced to a minimum. To bring this about it is usually necessary for certain employees in one department to work overtime or to make an extra effort so that some one else is not waiting for the job they are doing and this is one of the times when co-operation between supervising officers and employees is of direct benefit because without it there is frequently objection on the part of the employees to work the necessary overtime to help some one else.

Absolute fairness in handling this is also necessary because if the employee loses confidence in the supervising officer's fairness in matters of this kind, objection to the overtime worked will usually result.

Co-operation between shops and roundhouses is extremely important and roundhouse jobs should be given preference and promptly handled, because in this way many locomotive hours may be saved.

Increased shop output due to closer co-operation and better supervision over the maintenance of power will avail us little without co-operation between the transportation department and the mechanical department with respect to the use of power.

The railroads were taken over by the government not because it desired to go into the railroad business but because under the conditions which existed at that time increased efficiency was absolutely necessary. The efficiency with which

the railroads had been operated prior to that time was not the question at issue because, however great that may have been, still greater efficiency was required.

It has been the general impression among the people, if we are to judge by the remarks made when the subject was discussed, that government operation of railroads would simply establish a big political machine and that efficient railroad men would be displaced to make room for politicians and for that reason the present organizations would be destroyed and replaced by inefficient ones. Nothing could be farther from the truth so far as the present Railroad Administration is concerned. Order No. 1 of the director general has made it clear that under government control of railroads there would be no disposition to replace competent, experienced railroad officers or employees. In fact, I can say emphatically that no railroad officer or employee who is efficient and diligent in the performance of his work was ever so secure in his position as he is at the present time.

The question before us at the present time is not as to whether government control or government ownership of railroads is a good thing or a bad thing—that will be settled by the people after the war.

The question before the railroad officers and employees to-day is solely one of operating efficiency and still greater efficiency in order to meet the demands placed upon them. The operation of the railroads of the country as a unit during the war is the most severe test that has ever been placed upon the railroad men of the country. The operation of railroads is not only the Railroad Administration's job, it is also the railroad man's job. It is not the Railroad Administration's reputation that is at stake, it is the reputation of the railroad man that is at stake; this brings the issue down to each individual, which is just where it should be.

The question before us is not what is the other fellow doing nor what did we do last year, but what am I doing now to help increase the efficiency of railroad operation. This question will be best answered by the record of achievement.

The railroad men of the country have furnished their full quota for the front in all branches of service; they have gone over the top in the Liberty Loans; they have repaired more locomotives and pulled more tons of freight than ever before and I am sure that the record of operating efficiency will be equally as good during the time the railroads are under the control of the administration.

SUPERHEATERS ON ROTARY SNOW PLOWS

The use of highly superheated steam in rotary snow plows provides a substantial increase in the power of the plow and also reduces the fuel and water consumption, so that the danger of running out of fuel and water at some point where an additional supply cannot readily be obtained is considerably lessened. In a recent example of the application of superheaters to a rotary snow plow on a western road, the operating results obtained showed very plainly the advantages over a plow using saturated steam.

On this railroad it is necessary to use plows throughout nine months of the year, beginning about the middle of September, and in order to keep the road open in the face of the numerous heavy snow storms the plows must be operated at maximum capacity for considerable periods. The operating officers have been highly gratified with the results of superheating this plow and report that it is more economical on coal and water than a plow using saturated steam, because it can be operated indefinitely at full capacity. It has established its superiority over plows using saturated steam in the prompt and effective clearing of the road.

This plow is equipped with the Locomotive Superheater Company's Type A superheater, the arrangement of the super-

heater being similar to that employed on locomotives. The boiler is 11 ft. 2 in. long over tube sheets and the superheater units, of which there are twelve, extend to within 24 in. of the back tube sheet.

CONSERVATION IN FUEL OIL BOILER PLANTS*

BY EDWIN A. ROGERS

The opportunities for waste in a power plant are many and varied, but probably the place where the greatest avoidable loss occurs is in the boiler and furnace. While the furnace is in most cases a part of the boiler itself the losses of fuel, as represented by heat, should be considered separately.

Taking first the furnace we have the following possible losses and the means of preventing them: First, by allowing a greater amount of air than is necessary for proper combustion to enter the furnace, the temperature of the gases leaving the fires and passing across the tubes is considerably reduced. This reduction of temperature in these gases reduces the quantity of heat which will be absorbed by the water through the tubes and thus a large amount of heat which should go into the water goes out the stack. This single item of excess air to the furnace is probably responsible for a greater loss in fuel than all the other losses in the boiler combined. The remedy is simple if proper care is paid to the boiler dampers, particularly the one between the boiler outlet and the flue to the stack, for by closing in on this damper the draft in the boiler is reduced and consequently the amount of air which will be pulled into the furnace. To determine how much the air to the furnace can be reduced an analysis of the flue gases should be made. This analysis can be made in a very few minutes with a simple piece of apparatus, by any plant engineer, so that there is no excuse for any plant allowing this loss to continue. This fuel loss due to excess air is true of coal-burning plants as well as those using oil, and the same remedy applies. Care must be taken, however, to see that the air supply to the furnace is not curtailed to too great an extent, for then incomplete combustion of the fuel would result. This would cause a loss by way of the stack due to unburned gases and also decrease the absorbing power of the tubes, because in all probability a large amount of soot would be deposited on them by the smoke which would accompany the incomplete combustion.

The second furnace loss would be that due to using an excess amount of atomizing steam where oil is the fuel and steam is used for this purpose. The amount of steam required for atomizing really depends to a considerable extent on the furnace conditions and air supply, but where these conditions are proper the atomizing steam should be just sufficient to properly break up the oil. Experience has shown that the average plant uses three to five per cent of the total amount of steam generated for atomizing the oil, whereas this amount can be reduced to approximately one per cent. Of course all of this steam is lost out the stacks; in fact it is a double loss, for the steam after it enters the furnace will be raised to the temperature of the furnace gases, thus taking more heat which should go into the boiler.

Coming to the boiler proper we have first another excess air loss if there are cracks in the brickwork or boiler setting. As there is a draft inside the setting, air will rush in through any slight cracks or openings, thus cooling down the gases passing through inside. To detect these air leaks pass a candle flame or torch along close to the wall where any cracks show, and if air is going in the flame will be pulled in, wherever such leaks occur the cracks should be stopped up

with something which will set properly and make a bond with the brick.

Another appreciable loss is that due to radiation from the setting. This loss can be greatly reduced by covering both the top and sides of the boiler with some good insulating material. This insulating material will not only keep the heat in the boiler but if properly put on will prevent a large amount of air from going in. Where the temperature of the walls will be over 500 deg. F. after the insulating material has been put on, magnesia-asbestos covering should not be used, as it disintegrates at a temperature slightly above this. There are various other forms of insulation which have good insulating qualities and will also stand high temperatures.

Coming to the tube surface of the boiler we find two causes of lost heat. As previously stated if soot forms on the tubes it acts as a heat insulator and prevents passage of heat through the walls of the tubes. By having proper combustion, very little soot will be formed, but even when burning oil under apparently good conditions we find a deposit on the tubes, this deposit being of an ashy nature. This deposit should be removed either by scraping it off or blowing it off with a steam jet. A number of recent installations of oil-fired boilers have included soot blowers as part of the boiler equipment.

On the other side of the tube surface we have another heat insulator to contend with in the form of scale which is deposited from the water. This scale prevents heat from passing through the tube to the water and is not only the cause of a heat loss in this respect but also causes tube losses, for when the water cannot get in contact with the tube, the metal becomes so hot that it blisters and burns and it becomes necessary to replace the tube. Naturally the first solution of this difficulty would be to get water which will not scale the tubes. Unfortunately this is seldom possible and we should then try other means to remove or prevent this scale. In most cases the method would be to use a tube cleaner which grinds the scale out, but this is a slow, expensive process. In a plant of any size a water softener would probably be a profitable investment if the water had any great amount of scale-forming material in it. Some plants use boiler compound to soften the scale, but the softening should preferably be done before the water enters the boiler. Probably the best method to assure clean boilers is that recently adopted in several large power plants and consists of using only distilled water for make-up purposes.

Another important item, if the boilers are of the water-tube type, is the condition of the baffles. If the baffles between the different gas passages are not tight the gases will be pulled through by the shortest route to the stack, thus by-passing a large amount of the tube surface. The remedy here is to keep all baffles tight and in good condition.

Other points to be watched on the boiler are the blow-off valves, which must be tight to prevent leakage of hot water, safety valves to prevent steam leaks and all other valves or fittings where leaks of steam or hot water might occur.

Leaving the boilers, the steam passes to pumps, engines or various other steam-driven apparatus and on the way it travels through pipes or valves. If these pipes are covered with a good insulating material the transmission loss is small, but on the other hand if the pipe is bare the loss is large. An uncovered pipe radiates just about ten times the amount of heat that would be radiated if the pipe was covered with one inch of good insulation.

In the engines and auxiliaries all care should be taken to eliminate friction, leaking joints, leaking valves, etc., for all of these things mean waste of fuel. If the engines in a plant are operating condensing, the vacuum should be kept high to get the greatest possible steam economy from the engine. If engines, pumps, compressors, etc., are operating non-

*From a paper presented before the Pacific Railway Club.

condensing, all of the exhaust steam or as much of it as possible should be utilized to heat feed water and fuel oil.

There are a great many small losses in a plant which have not been enumerated, but it is not because they are unimportant. Any leak however small should be stopped, for they add up to a large total.

As stated in the beginning the greatest opportunity for waste is in the boiler, and with this in mind a considerable amount of attention has been paid to eliminating the human element from boiler control. The automatic stoking of coal has been successful for some time and we now have various automatic devices for controlling oil fires, some of which show every indication of being successful. This I believe will be the ultimate solution of our firing problem.

This may all seem very elemental and an old story, but it

is something that needs continued repetition to the men in your plants if it is to have an effect. Ask yourself the following questions and if the answer to them is satisfactory you are doing considerable toward fuel conservation:

Is the right amount of air being used for the fires?

Is the atomizing steam cut down to a minimum?

Is the boiler setting tight and well insulated?

Are the boiler tubes clear of soot and scale?

Are all the valves and fittings tight and working properly?

Are your steam pipes covered with insulating material?

These questions cover only part of the plant, but a part which is all-important. It is perfectly safe to make the assertion that the average plant using fuel oil has a preventable loss of at least five per cent and probably ten per cent of its fuel in the boiler room.

VIRGINIAN 2-10-10-2 LOCOMOTIVES

Built for Heavy Grade Pusher Service; Weight
684,000 lb.; Tractive Effort, Compound, 147,200 lb.

TEN Mallet Locomotives having a tractive effort of 147,200 lb. working compound and 176,600 lb. working simple, are now being delivered to the Virginian Railway by the American Locomotive Company. These locomotives were built to meet the problem of handling a constantly increasing volume of traffic on an exceptionally difficult section of railroad.

The portion of the line between Elmore and Clark's Gap on the Deepwater division, a distance of about 14 miles, has a grade for the last $11\frac{1}{2}$ miles of 2.07 per cent with maximum compensated curves of 12 deg. For the first two and one-half miles the grade is .5 per cent. This 14 miles

At present, trains passing over the mountain section are operated by one 2-6-0 type Mallet road engine, with a tractive effort of 90,000 lb., at the head end and two 2-8-2 Mallet pusher engines, with a tractive effort of 115,000 lb. each, behind. The maximum tractive effort thus available is 320,000 lb. per train, which enables the handling of 4,500 tons in 60 cars having an average weight for car and load of 75 tons.

The traffic volume is still growing, and as the track is single, and as it is not desired to increase the number of engines on any train above three, it has been found necessary to put still larger locomotives into service. The unusually

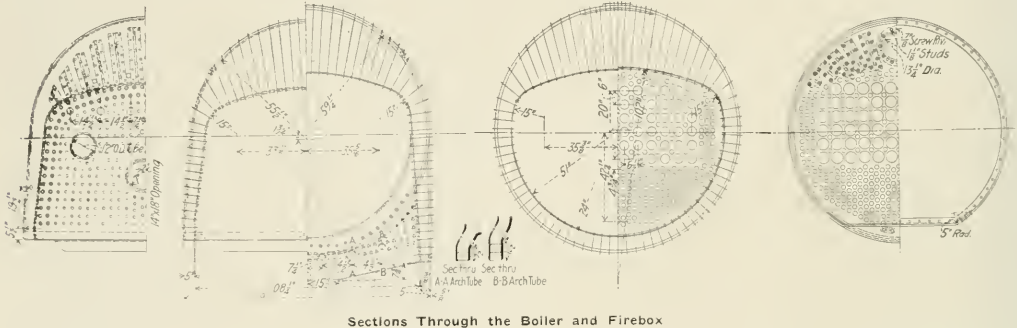

is all single track and includes five tunnels, which compel the use of an absolute block system. It is the crucial part of the entire system, as all the eastbound tonnage of the Virginian passes over it.

During the last 11 years Mallet locomotives have been employed in handling this traffic. The size and power of these locomotives have progressively advanced to keep pace with the growth in volume of traffic. The first installment consisted of four engines of the 2-6-6-0 type with tractive effort of 70,800 lb. Next in sequence were eight of the same wheel arrangement but with a tractive effort of 90,000 lb. The third installment consisted of one engine of the 2-8-8-2 type with a tractive effort of 100,800 lb. The fourth lot was six 2-8-8-2 type with a tractive effort of 115,000 lb.

large locomotives under discussion were developed in order to accomplish this result.

Upon receipt of the new locomotives trains will be composed of one of the 2-8-8-2 Mallet engines having a tractive effort of 115,000 lb., ahead and two of the new 2-10-10-2 Mallet engines, each having a tractive effort of 147,200 lb., behind, giving a total tractive effort for the train of 409,400 lb. This train will have a weight of 5,850 tons, the equivalent of 78 cars having an average gross weight of 75 tons each.

The 2-8-8-2 type Mallets which will be used on the head end of the train were built by the American Locomotive Company in 1912 and 1913. At that time these engines were the most powerful locomotives in the world. The fol-

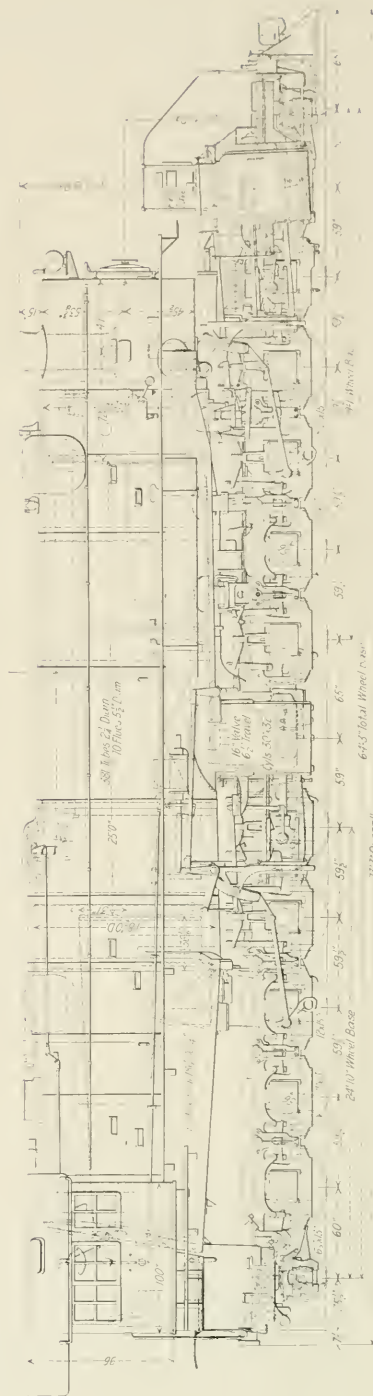
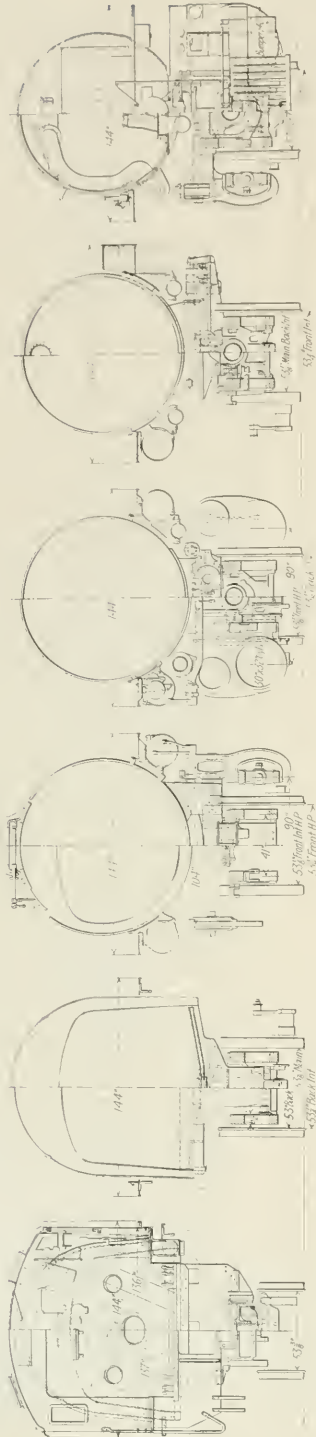

Elevation and Cross Sections of the Virginian 2-10-10-2 Type Locomotive

lowing comparison shows the extent to which these engines are exceeded in the new 2-10-10-2 type:

	2-8-2 type	2-10-10-2 type	Per cent. increase.
Total weight of engine, lb.	540,000	684,000	26.6
Total weight, engine and tender, lb.	752,000	898,300	19.5
Heating surface, sq. ft.	6,909	8,606	24.5
Superheating surface, sq. ft.	1,311	2,120	61.7
Tractive effort, compound, lb.	115,000	147,200	28
Tractive effort, simple, lb.	138,000	176,600	28

Apart from the enormous weight and power of the locomotive as a whole, some of the dimensions of the boiler are impressive as showing the extent to which the usual limits were exceeded in its design and construction. At the first course it is 105½ in. in diameter outside, while the outside diameter of the largest course is 112⅞ in. The barrel is fitted with 381 tubes 2¼ in. in diameter and 70 flues 5½ in. in diameter, 25 ft. long. A combustion chamber 36 in. long is included. The firebox is 181 1/16 in. long and 108¼ in. wide. The front portion of the firebox is included with the combustion chamber behind a Gaines fire-wall, so that the grate is about 144 in. long and has an area of 108.75

for service on Virginian tracks. The shipping arrangement required considerable planning before the various carriers could be convinced that they could safely accept and move via their lines, locomotives of such size and weight.

In preparing for shipment of large locomotives it is first necessary to submit diagrams showing the estimated height and width clearance dimensions, and the distribution of weights on each axle to the operating or engineering department of each carrier over whose line it is intended to route the shipment, in order to secure their agreement to handle it when offered to their line. If some projection exceeds the carrier's clearance limitations, an effort is made to meet the objection by removing that part, if possible, and reapplying it on arrival at destination. Or, if the weights are too heavy for the trestles or the bridges via a natural route, an effort is made to find a way to ship via a detour route.

These large locomotives presented an unusual problem. It was impossible to ship them completely assembled and moving dead on their own wheels. After the consideration of many plans, it was finally decided to leave the boiler on

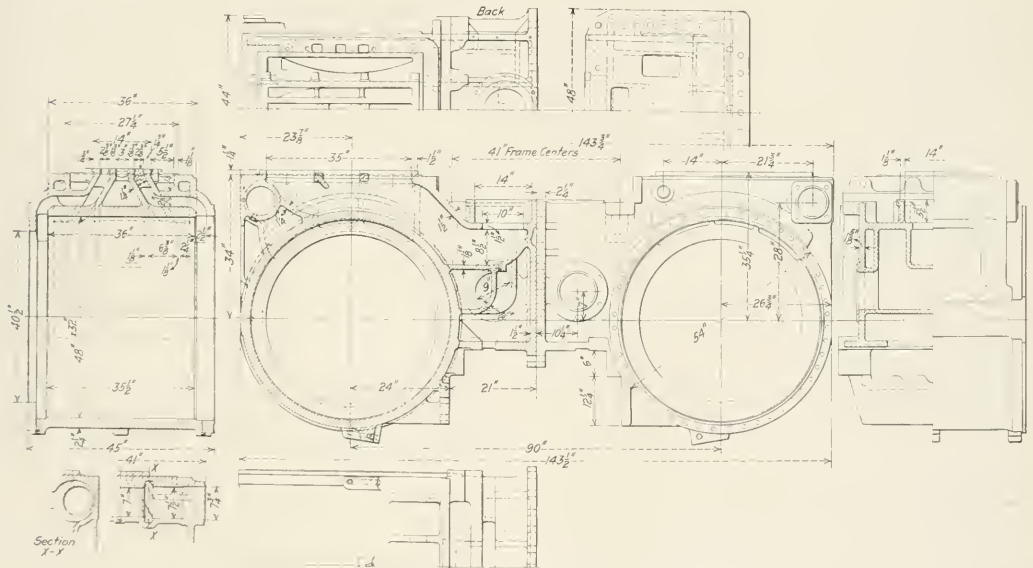

Low Pressure Cylinders of the Virginian Mallet Type Locomotive

sq. ft. A total heating surface of 8,606 sq. ft. and a superheating surface of 2,120 sq. ft. are obtained.

The high and low-pressure cylinders are 30 in. and 48 in. in diameter, respectively, which gives a cylinder ratio of 2.56. The details of the unusually large low-pressure cylinder castings are shown in one of the drawings. With a cylinder spacing of 90 in. between centers the clearance width is 143½ in.

The high-pressure valves are of the piston type, 16 in. in diameter, while outside admission slide valves are used for the low-pressure cylinders. Steam admission is controlled by the Chambers outside connected throttle and a Lewis reverse gear is used. Both the front and trailer trucks are of the Woodward type and the tender trucks are equalized. The design as a whole follows the builder's ordinary practice, differing from previous designs only in modifications made necessary by the increased size and capacity.

These engines were built at the Schenectady works and the contract called for delivery completely erected and ready

for service on Virginian tracks. The shipping arrangement required considerable planning before the various carriers could be convinced that they could safely accept and move via their lines, locomotives of such size and weight. The cab, low-pressure cylinders, and some other parts were removed and the remaining skeletons with their tenders were shipped on their own wheels. Each locomotive required one flat, one gondola, and one box car to carry the loose and detached parts.

Authority was eventually secured for shipping in this manner although under special operating instructions and via detour routes. Each locomotive was accompanied by a messenger who had sleeping quarters fitted up in the cab which was loaded on a flat car. Approximately two weeks has been the actual running time from Schenectady, N. Y., to Princeton, W. Va.

The principal data and dimensions are as follows:

General Data	
Gage	14 ft. 8½ in.
Service	Freight
Fuel	Bit coal
Tractive effort, simple	176,600 lb.
Tractive effort, compound	147,200 lb.
Weight in working order	684,000 lb.

Weight on drivers	617,000 lb.
Weight on leading truck	32,000 lb.
Weight on trailing truck	35,000 lb.
Weight of engine and tender in working order	898,300 lb.
Wheel base, driving	19 ft. 10 in.
Wheel base, total	64 ft. 3 in.
Wheel base, engine and tender	97 ft.

Ratios

Weight on drivers ÷ tractive effort, simple	3.2
Weight on drivers ÷ tractive effort, compound	3.42
Total weight ÷ tractive effort, compound	4.6
Tractive effort, compound × diam. drivers ÷ equivalent heating surface*	609.4
Equivalent heating surface* ÷ grate area	108.4
Firebox heating surface ÷ equivalent heating surface* per cent.	4.4
Weight on drivers ÷ equivalent heating surface*	52.4
Total weight ÷ equivalent heating surface*	58.0
Volume equivalent simple cylinders	41 cu. ft.
Equivalent heating surface* ÷ vol. cylinders	287.4
Grate area ÷ vol. cylinders	2.7

Cylinders

Kind	Compound
Diameter and stroke	30 in. and 48 in. by 32 in.

Valves

Kind	h. p. piston; l. p. side
Diameter	h. p., 16 in.
Greatest travel	h. p., 6½ in.; l. p., 6 in.
Steam lap	h. p., 1 in.; l. p., 1½ in.
Exhaust clearance	h. p., ½ in.; l. p., 9/16 in.
Lead in full gear	h. p., ¼ in.; l. p., 3/16 in.

Wheels

Driving, diameter over tires	56 in.
Driving, thickness of tires	3½ in.
Driving journals, main, diameter and length	12 in. by 15 in.
Driving journals, others, diameter and length	11 in. by 15 in.
Engine truck wheels, diameter	30 in.
Engine truck, journals	6½ in. by 13 in.
Trailing truck wheels, diameter	30 in.
Trailing truck, journals	6½ in. by 13 in.

Boiler

Style	Ext. wagon top
Working pressure	215 lb. per sq. in.
Outside diameter of first ring	105½ in.
Firebox, length and width	181 1/16 in. by 108½ in.
Firebox plates, thickness, all	¾ in.
Firebox, water space	Front, 5½ in.; sides and back, 8 in.
Flues, number and outside diameter	381—2½ in.
Flues, number and outside diameter	70—5½ in.
Tubes and flues, length	25 ft.
Heating surface, tubes and flues	8,090 sq. ft.
Heating surface, firebox, including arch tubes	516 sq. ft.
Heating surface, total	8,606 sq. ft.
Superheater heating surface	2,120 sq. ft.
Equivalent heating surface*	11,786 sq. ft.
Grate area	108.7 sq. ft.

Tender

Tank	Water bottom
Frame	Cast steel
Weight	214,300 lb.
Wheels, diameter	33 in.
Journals, diameter and length	6 in. by 11 in.
Water capacity	13,000 gal.
Coal capacity	12 tons

*Equivalent heating surface = total evaporative heating surface + 1.5 times the superheating surface.

along the right-of-way was discussed at length. It developed that there was considerable difference of opinion on this subject. Some of the members stated that they were having no trouble, while others expressed the opinion that oil burning locomotives set out fires as frequently as locomotives burning coal. The causes of fires suggested were, combustible matter in the sand used for cleaning the flues, carbon deposits forming on the heating surfaces and tar in the oil. Some roads reported that they were using netting in the front end or over the stack to break up combustible matter. Trouble due to tar in the oil could only be corrected by more careful refining.

RAILROAD ADMINISTRATION NEWS

The allocation of freight cars and locomotives ordered by the Railroad Administration to the various railroads has encountered some obstacles because many railroad companies are displaying considerable reluctance to accept and pay for the standard equipment. The original plan was to have the Railroad Administration acquire the cars and locomotives with the idea of disposing of them to the railroad companies after the period of government control is over if the railroads are returned to their owners. This plan was changed, however, and the 100,000 freight cars and the 1415 locomotives ordered were definitely allocated to the railroad companies to be charged against their budgets and financed by the companies. The roads were asked how many of the standard locomotives they desired and they placed their orders for various numbers, in some instances, at least, because there was no opportunity to secure any other engines.

About September 1 some of the car builders began to turn out the new freight cars in considerable quantities but a large number of roads have objected to accepting them. Most of the objections have been on the ground that the companies did not want to pay for the cars at the high prices prevailing this year as all the revenue from their use goes to the Railroad Administration and the companies can get nothing but interest and the amount of the depreciation. In other cases the objection was to the type of the standard cars. The Railroad Administration is taking the position that the companies must take the cars and pay for them.

VIOLATION OF SAFETY LAWS

In General Order No. 46 the director general states that the records of the Interstate Commerce Commission and the reports of its inspectors show so many instances of violation of federal statutes for the promotion of safety that it is evident that sufficient attention is not being paid to the provision of General Order No. 8 issued on February 21 that the safety laws, and orders of the Interstate Commerce Commission made in accordance therewith, must be fully complied with. Enforcement of the provisions of this paragraph of the order will be placed under the direction of Frank McManamy, assistant director of the division of operation, who will receive reports of such violations and handle them either with the regional directors, or direct, if necessary.

The Division of Operation has also issued Mechanical Department Circular No. 3 signed by Mr. McManamy, stating that attention has been brought to numerous instances where it has been necessary for Interstate Commerce Commission inspectors to order locomotives out of service for repairs under circumstances which indicate wilful violation of the federal laws regarding safety and also where locomotives were not in condition to render efficient and economical service. In the future, the circular says, master mechanics and shop and roundhouse foremen will be required to know that locomotives are in good condition before they leave the terminals.

FUEL ECONOMY ON OIL BURNING LOCOMOTIVES

At the recent meeting of the Traveling Engineers' Association the subject of economy on oil burning locomotives was discussed. C. H. Holdredge, Southern Pacific, expressed the opinion that excess air is responsible for many of the difficulties encountered in the operation of oil burning locomotives, as it is the principal cause of firebox leaks. In his opinion with burners situated at the front of the firebox the best practice was to admit about 60 per cent of the air at the burner and the remaining 40 per cent at the point where the direction of the flame is changed. Analysis of the front end gases had made it possible to determine the arrangement which gave the most efficient combustion. F. P. Roesch, fuel supervisor, U. S. R. A., advocated the use of brick arches on oil burning locomotives. He stated that he had found the use of a burner at the back end of the firebox in conjunction with a brick arch gave better results than the front end burner with a flash wall. In using the brick arch it had been found necessary to alter the oil valve so that a pilot light was kept burning continuously. This prevented explosions from sudden ignition, which often knocks down the brick work. Mr. Roesch spoke of the necessity of protecting fuel oil in storage from the heat of the sun, which in warm climates distills off the lighter constituents of the oil. The question of oil burning locomotives causing fires

PURCHASING COMMITTEE TO ORGANIZE STORES DEPARTMENT

E. J. Roth, purchasing agent of the Chicago, Indianapolis & Louisville, is to be appointed manager of a stores section being organized by the Central Advisory Purchasing Committee of the Railroad Administration to exercise jurisdiction over the storekeeping departments of the railroads, some of which are now under the jurisdiction of the purchasing department, but some of which are under the jurisdiction of the operating department. It is proposed to organize a staff of storekeeping officials, one for each region reporting to Mr. Roth and to work out uniform plans for handling this department.

POLITICAL ORDER MODIFIED

Director General McAdoo has agreed to a slight modification of his General Order No. 42, requiring railroad men to abstain from political activities. The changes are incorporated in General Order No. 48 issued as a substitute for No. 42 and Supplement No. 1 thereto.

- "It is ordered that no officer, attorney or employee shall:
 - "1. Hold a position as a member or officer of any political committee or organization that solicits funds for political purposes.
 - "2. Act as a chairman of a political convention or use his position in the railroad service of the United States to bring about his selection as a delegate to political conventions.
 - "3. Solicit or receive funds for any political purpose or contribute to any political fund collected by an official or employee of any railroad or any official or employee of the United States or any state.
 - "4. Assume the conduct of any political campaign.
 - "5. Attempt to coerce or intimidate another officer or employee in the exercise of his right of suffrage. Violation of this will result in immediate dismissal from the service.

"6. Neglect his railroad duties to engage in politics or use his position in the railroad service of the United States to interfere with an election. An employee has the right to vote as he pleases, and to exercise his civil rights free from interference or dictation by any fellow employee or by any superior, or by any other person. Railroad employees may become candidates for and accept election to municipal offices where such action will not involve neglect on their part of their railroad duties, but candidacy for a nomination or for election to other political office, or the holding of such office, is not permissible. The positions of notaries public, members of draft boards, officers of public libraries, members of school or park boards, and officers of religious and eleemosynary institutions are not construed as political offices.

"7. In all cases where railroad officers, attorneys and employees were elected to political offices prior to the issuance of General Order No. 42, August 31, 1918, they will be permitted to complete their terms of office so long as it does not interfere with the performance of their railroad duties. After the completion of said terms of office, they will be governed by the provisions of this order.

"8. In all cases where railroad officers, attorneys and employees were nominated for political offices, and had become candidates therefor prior to the issuance of General Order No. 42, August 31, 1918, they will be permitted to hold and complete the terms of office to which they may be elected at the general election to be held November, 1918, to the extent that the holding of such offices shall not interfere with the performance of their railroad duties. After the completion of such terms of office, they shall be governed by the provisions of this order.

"Railroad men have given ample proof of their loyalty to their government. I am confident that they will gladly and patriotically accept now those reasonable governmental regulations concerning political activity which their welfare and America's cause demand. They are the same regulations in their general scope and application as all other government employees have lived under for many years without the loss of any essential rights and with added dignity to their citizenship."

The new order was approved by President Wilson by his signature.

FREIGHT CAR OUTPUT IN 1918

The total addition to the freight car equipment of the country up to September 1 this year has been approximately 40,000 cars, according to reports recently compiled. This includes private cars and tank cars. The total output of the

car builders up to August 31 was 63,139, including 27,718 for the army and navy and foreign governments, and in addition the output of the railroad shops for the first six months of the year was 4,414. The number of freight cars on order and undelivered on August 31 was 106,172 for domestic service, and 55,835 for foreign service, the total for domestic service including the 100,000 cars ordered by the Railroad Administration, of which some 500 have since been delivered.

DELIVERIES OF STANDARD LOCOMOTIVES

Of a total of 626 locomotives delivered to the railroads from August 1 to October 19, inclusive, 284 were of the U. S. R. A. designs, being distributed as follows:

Atlanta & West Point.....	1	8-Wheel Switcher
Baltimore & Ohio.....	37	Light Mikados
Central of New Jersey.....	10	Heavy Mikados
Chesapeake & Ohio.....	10	Heavy Mikados
Chicago & Alton.....	7	Light Mikados
Chicago & Eastern Illinois.....	15	Light Mikados
Chicago, Milwaukee & St. Paul.....	38	Heavy Mikados
Chicago Junction.....	10	6-Wheel Switchers
Cleveland, Cincinnati, Chicago & St. Louis.....	6	Light Mikados
Erie.....	8	8-Wheel Switchers
Grand Trunk (Eastern).....	10	Light Mikados
Lake Erie & Western.....	15	Light Mikados
Lehigh & Hudson River.....	4	Light Mikados
Lehigh Valley.....	5	Light Mikados
Louisville & Nashville.....	10	Light Mikados
New York, Chicago & St. Louis.....	20	Heavy Mikados
Pittsburgh & West Virginia.....	3	Light Mikados
Pittsburgh, McKeesport & Youghiogheny.....	10	Light Mikados
Seaboard Air Line.....	10	Light Mikados
Toledo & Ohio Central.....	5	Wheel Switchers
Toledo & Ohio Central.....	15	Light Mikados
Western & Atlantic.....	20	Light Mikados
Wheeling & Lake Erie.....	1	8-Wheel Switcher
	14	Heavy Mikados

RAILWAY SHOPS HELPING OUT THE BUILDER

At the request of the Baldwin Locomotive Works, the mechanical department of the Railroad Administration has ascertained that at some shops there are machines which are not being used to maximum capacity and arrangements have been made to allow the surplus capacity to be used on work for the Baldwin company.

The Philadelphia & Reading shop at Reading, Pa., will plane and slot locomotive frames at the rate of two per week and will build new boilers at the rate of one per week.

The Delaware, Lackawanna & Western will plane and slot 50 sets of frames and finish 50 sets of rods per week.

The Lehigh Valley shops at Sayre, Pa., will plane three sets of frames per week and the shops at Easton will finish 16 driving boxes per week.

The Erie at its Meadville, Pa., shops will finish shoes and wedges for four locomotives per week and at the Susquehanna shops cylinders for one locomotive per week and frames for three locomotives per week. At its Dunmore shops it will finish driving boxes and shoes and wedges for three locomotives per week.

The New York Central will build new boilers at its West Albany, N. Y., shops.

REPORT ON CONDITION OF LOCOMOTIVES

The table showing the condition of locomotives on the roads controlled by the Railroad Administration for the week ending September 28, 1918, indicates that as far as locomotives are concerned the railroads are in pretty good shape, having a general average of only 14.4 per cent of locomotives

LOCOMOTIVE CONDITION REPORT FOR THE WEEK ENDING SEPTEMBER 28, 1918,

Regions	No. of Locos. on line	No. of Locos. serviceable	No. of Locos. awaiting service 24 hrs.	Per cent	Locos. turned out of shop 1918	Locos. repaired	Foreign Locos.	Number of employees 1918	1917
Allegheny.....	10,045	8,617	1,428	14.2	1,555	1,463	36	44,763	39,079
Central Western.....	11,913	10,466	1,447	15.5	802	655	53	60,924	54,396
Eastern.....	18,395	15,845	2,550	13.8	1,911	1,583	78	78,991	71,091
Northwestern.....	9,267	8,011	1,256	13.5	375	357	19	32,368	29,922
Peachontas.....	1,968	1,741	227	11.5	194	169	6	10,178	9,537
Southern.....	6,390	5,428	962	15.0	361	316	29	25,257	22,374
Southwestern.....	5,148	4,279	869	16.8	377	281	35	22,845	21,139
Total	63,126	53,987	9,139	14.4	6,038	4,806	236	275,326	247,533

in shops. It is particularly gratifying to notice that the number of locomotives turned out of the shops for this week is an increase of 1,277 over the number turned out during the same week of last year. At the same time the number of employees increased 27,793 for the week, over the number employed during the corresponding week last year. During the week 236 locomotives were repaired in shops on foreign lines.

The need for skilled railroad employees has become so great that the Railroad Administration is taking steps to have returned to railroad service those who have enlisted or have been drafted into the military service, but not yet sent abroad, who are not being employed in such a way as to secure the full utilization of their special skill and experience. The purpose is not to interfere with the placing of railroad men in military railway service, but rather to make it possible to spare the men needed for that service without undue depletion of the working forces of the railroads.

COMPENSATION FOR HELPERS—SHOP CRAFTS

Amendment No. 1 to Supplement No. 4 to General Order No. 27, recently issued by the director general provides:

For helpers in the basic trades specified in Supplement No. 4 to General Order No. 27, who, on January 1, 1918, were receiving less than 32 cents per hour, establish a basic minimum rate of 32 cents per hour; to this basic minimum rate, and all hourly rates of 32 cents per hour and above in effect as of January 1, 1918, add 13 cents per hour, establishing a minimum rate of 45 cents per hour.

PHYSICAL EXAMINATION FOR MECHANICS

The Eastern regional director in Order 3000-421, dated October 11, quotes as follows from a communication received from the director, Division of Operation, under date of October 7, in regard to physical examinations required in the employment of the locomotive and car repair organizations:

We continue to receive complaints of unnecessarily rigid physical examinations required in the employment of the locomotive and car repair organizations. Your attention is again invited to the following paragraph in the letter addressed to Mr. Wharton by the director general under date of February 14:

"Mechanics applying for employment will not be denied such employment for any cause other than inability to perform the work. This preference rule will be in effect as long as three-year apprentices or promoted helpers are employed at mechanics' rates."

While I do not intend you to understand that physical examinations should be eliminated, it is clear that the requirements should be decidedly more liberal than in the past, and the fact that an employee cannot pass a satisfactory examination to enable him to participate in relief and benefit associations should not bar him from employment, provided he waives membership in such associations. I understand that men now are in some cases accepted for employment upon such waiver, but only for a period of six months.

ANOTHER SUPPLEMENT TO ORDER No. 27

The director general has issued supplement No. 6-A to General Order No. 27 by which Supplement No. 6 to General Order No. 27 is amended by adding thereto the following:

Where differences of opinion arise necessitating a formal interpretation of any wage order issued by the director general, and where the question involved is of general application and covers a large number of railroads, application for such interpretation may be made either by a regional director or by the chief executive of the railroad organization representing the class of employees involved or the chairman of any railway board of adjustment or the director of the Division of Labor. Such application shall be sent to the office of the director of labor, and he will record and transmit it to the Board of Railroad Wages and Working Conditions, which will promptly investigate and make recommendation to the director general. Upon the receipt of interpretation from the director general, the director of labor will send such interpretation to the railway boards of adjustment for their information and guidance.

INSPECTION OF ASHPANS AND SPARK ARRESTERS

Mechanical Department Circular No. 5 provides that the following rules will govern in the care and inspection of ashpans and spark-arresting appliances in locomotives used on railroads under federal control:

1. A careful and thorough inspection of every part of the spark-arresting appliances in the front end of locomotives must be made every time the

front end door is opened for whatever purpose; but at intervals of not more than seven days, and at the same time the ashpans, hoppers, slides or other apparatus for dumping cinders and dampers, must also be inspected. Observe if the slide or hopper operates properly and closes tight. When conditions such as extreme drought or the state of adjoining property or crops require it, this inspection must be made at least once every 24 hours.

2. A record of condition on arrival must be made under the proper heading on an approved form, immediately following each inspection, with the date made, together with a complete statement of any repairs or renewals required. The above record to be made and signed by the person who made the inspection.

3. Nettings and spark arresters must be put in perfectly tight and serviceable condition before the locomotive is put into service. Renew netting and plates in front end when worn thin or defective, instead of patching them. Ashpans and hoppers must be tight, and dampers, slides or apparatus for dumping cinders must be in good working order, closing tight.

4. Record of repairs and renewals made must be entered under the proper heading on an approved form when repairs have been made, with the date, the entry to be made and signed by the person doing the work.

5. These are the minimum requirements, and local conditions or regulations requiring additional precautions are not affected hereby.

THE PROPER LOCATION OF LOCOMOTIVE CAB FITTINGS

BY HUGH G. BOUTELL

A subject, which up to the present time has not received the attention it deserves from locomotive designers, is that of the proper location of cab fittings on the large engines now being turned out.

In spite of the fact that the growing use of mechanical stokers, power grate shakers and other auxiliary equipment has greatly increased the number of valves, levers and pipes in the cab, the location of only a few of these fittings is determined in the drafting room, the rest being set up according to the best judgment of the men in the erecting shop. Even the reverse and throttle levers and whistle rigging, details the position of which is usually fixed on the engine drawing, are often located with no idea whatever as to convenience of operation.

In talking with a road foreman of engines on one of the large coal-carrying roads, the writer learned that a certain class of freight locomotives, very successful in many respects, was extremely unpopular with the enginemen owing to the unhandy position of the throttle lever. This lever was of the type that hangs vertically downward near the right side of the back-head, and was so short, with the lower end so high up, that in order to get a sufficiently straight pull back to open the valve, the runner had to stand up and use both hands. A longer lever, so mounted that the pull came in a straight line on a level with the engineman's shoulder when seated, would have remedied the trouble, and in fact this change was made on a subsequent lot of engines.

A similar case which came to my attention recently, was the location of the whistle lever on some passenger engines so far forward in the cab that it could not be reached unless the engineman left his seat. Even so slight a movement as this distracts the man's attention and requires time which should be given to other duties. This point has lately been recognized by railroad officers and is one of the reasons for the rapid increase in the use of power reverse gears, which do away with the old hand lever, the movement of which often required all of one man's weight and was even accompanied with considerable danger when attempted at high speed.

A frequent cause of bad language and sometimes of minor injuries to the enginemen is the placing of hot steam pipes in line with injector steam valves and other turret appliances. These should have as clear a space as possible all around them, so that they can easily be reached even in the dark. Of course the satisfactory location of valves and other fittings connected with the turret is a serious matter on large locomotives, where there is but little space between the top of the boiler and the cab roof. A layout of these fittings ought to be made in the drafting room, and the clear-

ances worked out with all possible care. The case of valves so located that the cab has to be removed in order to pack the stem would then be avoided.

Considering the great number of levers, valves and other fittings on a modern locomotive, it seems remarkable that they have been arranged even so well as is usually the case,

but this has been done more or less in spite of, rather than with the assistance of the designers of the engine. The attitude of the engine crew can do a great deal toward making a certain class of locomotives successful or otherwise, and for this reason alone, the proper location of cab fittings should receive the careful attention of locomotive builders.

DATA FOR STANDARD LOCOMOTIVES

Tonnage Rating Charts and Clearance and Weight Diagrams for the Government Locomotives Now Built

FOR the convenience to railway men handling the standard locomotives built by the Railroad Administration the following charts and diagrams are given, showing tonnage rating charts, prepared by H. S. Vincent, and clearance and weight diagrams, prepared by F. P. Pfahler, chief mechanical engineer, the Division of Operation, U. S. R. A., of the standard locomotives thus far built. As other standard locomotives are constructed similar charts and diagrams will

$$T = \frac{d^2 L .85 P}{W}$$

Where: T = Tractive power.
 d = Diameter of cylinders in inches
 L = Stroke in inches.
 P = Boiler pressure — lb. per square inch
 W = Diameter of driving wheels in inches.

The drawbar pull which varies with the resistance is shown on the charts by the inclined parallel lines. On straight level track this equals the tractive effort less the frictional resistance of engine and tender. In determining the latter resistance, the writer has adopted the method proposed by F. J. Cole, in which the engine and tender resistance is made up of the following:

- (a) Engine friction or energy required to overcome the

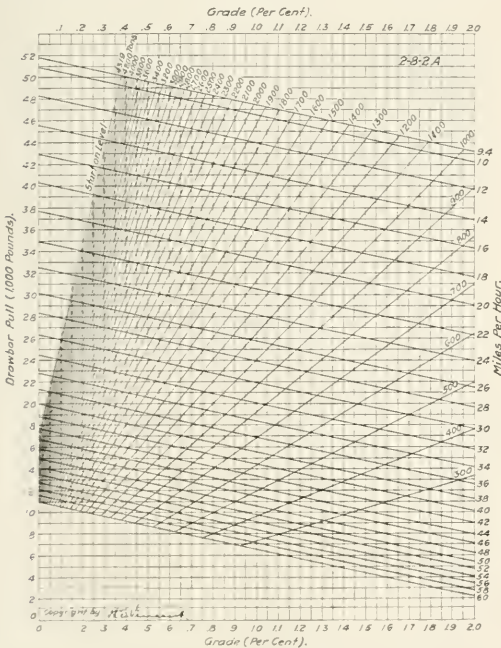

Tonnage Rating Chart for the Standard Light Mikado.

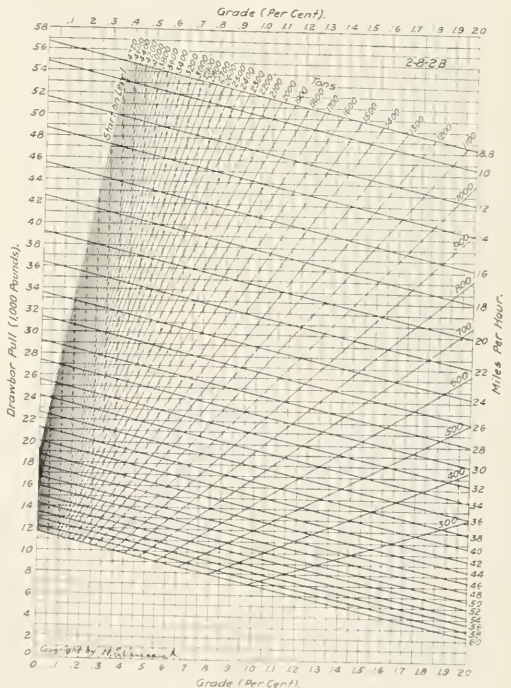

Tonnage Rating Chart for the Heavy Standard Mikado.

be published in connection with a description of the locomotives.

TONNAGE RATING CHARTS

The tonnage rating charts * are so designed that the maximum hauling capacity of the locomotives in tons of 2,000 lb. can be read directly from them for any combination of speed and grade within the given limits.

The tractive effort formula used in the calculation of the charts is:

friction of the driving wheels, pistons, valves, crossheads, etc., equal to weight on drivers in tons x 22.2 lb.

- (b) Resistance of engine and trailing trucks and two-

* These charts have been copyrighted by Mr. Vincent.

thirds of loaded weight of tender assumed to be the same as the cars in the train.

(c) Head air resistance of engine, assumed to be 120 sq. ft. x .002 V², in which V = velocity of train in miles per hour.

The tonnage curves are based on a frictional car resistance of four pounds per ton, which is a good average for the usual mixed freight trains with varying weights of cars and loading, when the rolling stock and roadbed are well maintained. However, the tonnage can be read from the charts for any other car resistance factor or any combination

TABLE I—FRICTIONAL RESISTANCE OF FREIGHT CARS
Speeds 5 to 30 M. P. H.

Weight in tons		Resistance (Lb. per ton)	
Loaded	Empty	Loaded	Empty
15	6	6.40	10.30
20	7.8	5.91	9.60
25	9.5	5.44	9.05
30	11.1	5.07	8.45
35	12.6	4.74	8.05
40	14.0	4.40	7.65
45	15.3	4.18	7.26
50	16.5	3.90	6.85
55	17.6	3.65	6.50
60	18.6	3.43	6.26
65	19.5	3.24	6.00
70	20.3	3.07	5.82
75	21.0	2.90	5.63

of resistance simply by converting them into terms of grade, using the following multipliers:

One pound car resistance = .05 per cent grade.

One degree curve uncompensated = .04 per cent grade.

For example: Find the tonnage of the light Mikado locomotive on a one per cent grade at a speed of 18 m.p.h., with a mixed train having a frictional car resistance of four

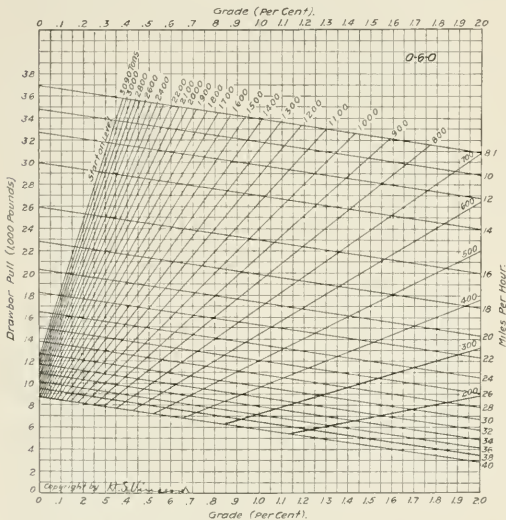

Tonnage Rating Chart for the Standard Six-Wheel Switcher

pounds per ton; also with a train of 50 tons loaded coal cars, having a resistance of three pounds per ton.

From the 2-8-2-A chart at the intersection of the ordinate for one per cent grade with the drawbar pull curve marked 18 m.p.h., we find the radial curve reading 1,500 tons.

For the train having 50 tons cars with three pound resistance, we select the ordinate equal to $1 - [(4 - 3) \times .05] = .95$ per cent grade, which at its intersection with curve for 18 m.p.h., reads 1,575 tons approximately.

Taking the same example and combining the grade with an eight degree uncompensated curve, we have for the mixed train, an equivalent grade of $1 + (8 \times .04) = 1.32$ per cent, which at 18 m.p.h. gives a rating of about 1,130 tons, and for the train with uniform loads we have an equivalent grade of $1 + (8 \times .04) - (1 \times .05) = 1.27$ per cent, which at 18 m.p.h. gives a rating of approximately 1,180 tons.

For Passenger and Express Service.—To avoid confusion,

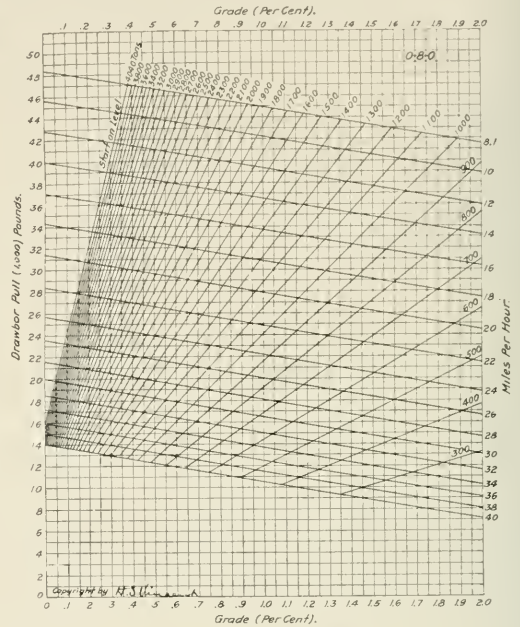

Tonnage Rating Chart for the Standard Eight-Wheel Switcher

the charts have been based on a frictional resistance of four pounds per ton, although in every case adjustment must be made for a greater resistance due to increased frictional re-

TABLE II—FRICTIONAL RESISTANCE OF FREIGHT CARS
From: Bulletin No. 43—University of Illinois—Edward C. Schmidt

Speed, miles per hour	Train resistance—Pounds per ton													
	Column headings indicate average weights per car													
	15	20	25	30	35	40	45	50	55	60	65	70	75	
6	7.7	6.9	6.1	5.5	4.9	4.4	4.1	3.8	3.5	3.3	3.2	3.1	3.0	
8	8.0	7.1	6.3	5.6	5.0	4.6	4.2	3.9	3.6	3.4	3.3	3.2	3.1	
10	8.2	7.3	6.5	5.8	5.2	4.7	4.3	4.0	3.7	3.5	3.3	3.2	3.1	
12	8.4	7.5	6.7	6.0	5.4	4.8	4.4	4.0	3.8	3.6	3.4	3.3	3.2	
14	8.7	7.8	6.9	6.2	5.5	5.0	4.5	4.2	3.9	3.7	3.5	3.4	3.4	
16	9.0	8.0	7.1	6.4	5.7	5.1	4.7	4.3	4.0	3.8	3.6	3.5	3.5	
18	9.3	8.3	7.4	6.6	5.9	5.3	4.8	4.5	4.1	3.9	3.7	3.7	3.6	
20	9.6	8.5	7.6	6.8	6.1	5.5	5.0	4.6	4.3	4.0	3.9	3.8	3.7	
22	9.9	8.8	7.9	7.0	6.3	5.7	5.2	4.8	4.4	4.2	4.0	3.9	3.8	
24	10.2	9.1	8.1	7.3	6.6	5.9	5.4	4.9	4.6	4.3	4.2	4.1	4.0	
26	10.5	9.4	8.4	7.5	6.8	6.1	5.6	5.1	4.8	4.5	4.3	4.2	4.1	
28	10.9	9.7	8.7	7.8	7.0	6.3	5.8	5.3	4.9	4.7	4.5	4.4	4.3	
30	11.3	10.0	9.0	8.0	7.3	6.6	6.0	5.5	5.1	4.9	4.7	4.5	4.5	
32	11.6	10.4	9.3	8.3	7.5	6.8	6.2	5.8	5.3	5.0	4.9	4.7	4.6	
34	12.0	10.7	9.6	8.5	7.8	7.1	6.5	6.0	5.5	5.3	5.1	4.9	4.8	
36	12.5	11.1	9.9	8.9	8.0	7.4	6.7	6.2	5.8	5.5	5.3	5.1	5.0	
38	12.9	11.4	10.2	9.3	8.3	7.6	7.0	6.5	6.0	5.7	5.5	5.3	5.2	
40	13.4	11.8	10.6	9.5	8.6	7.9	7.3	6.8	6.3	6.0	5.7	5.6	5.5	

sistance of passenger cars. For example: Find the tonnage which can be hauled by the heavy Mikado in passenger service on 0.5 per cent grade combined with six degree curve at 40 m.p.h.

From Table III we find the resistance for passenger

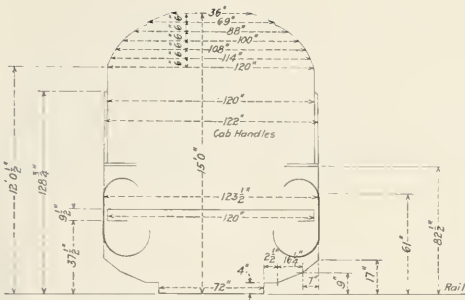

Heavy Mikado- For Loaded Engine.
For Light Engine, Heights Will Be About $\frac{1}{2}$ Greater.

Clearance Diagram for the Standard Heavy Mikado

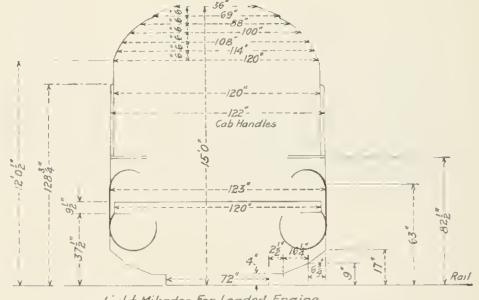

Light Mikado- For Loaded Engine.
For Light Engine, Heights Will Be About $\frac{1}{2}$ Greater.

Clearance Diagram for the Standard Light Mikado

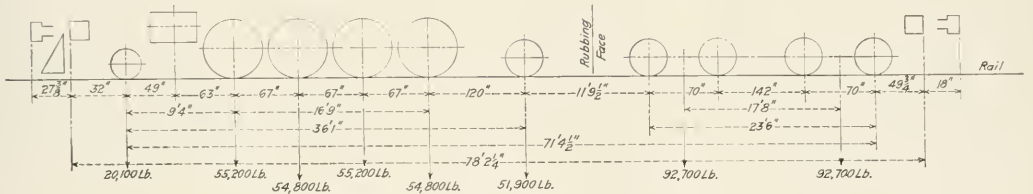

Light Mikado- Weight in Working Order. 10,000 Gal. Tender - Freight Trucks.

Wheel Loading and Spacing Diagram for the Standard Light Mikado

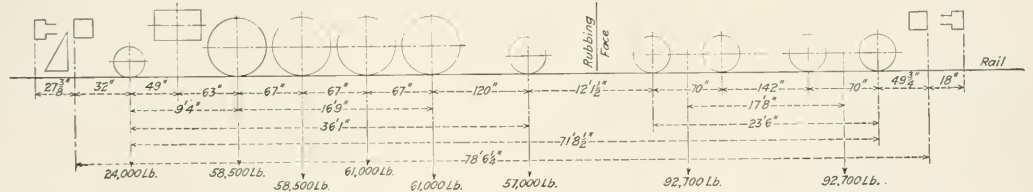

Heavy Mikado- Weight in Working Order. 10,000 Gal. Tender - Freight Trucks

Wheel Loading and Spacing Diagram for the Standard Heavy Mikado

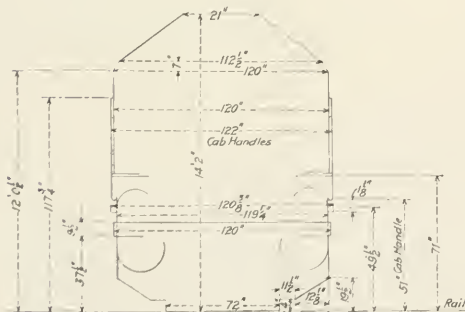

Six-Wheel Switcher- For Loaded Engine.
For Light Engine, Heights Will Be About $\frac{1}{2}$ Greater.

Clearance Diagram for the Standard Six-Wheel Switcher

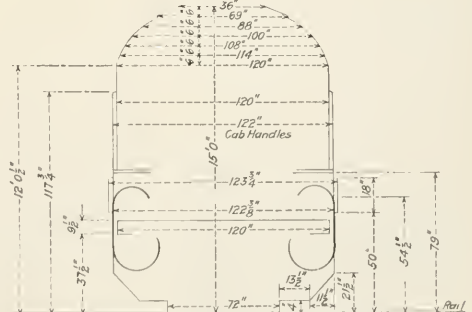

Eight-Wheel Switcher- For Loaded Engine.
For Light Engine, Heights Will Be About $\frac{1}{2}$ Greater.

Clearance Diagram for Standard Eight-Wheel Switcher

coaches at 40 m.p.h. is 6.65 lb. per ton. The equivalent grade is then:

$$.5 + (6 \times .04) + (2.65 \times .05) = .8725 \text{ per cent.}$$

From the 2-8-2-B chart at the intersection of the ordinate for .8725 per cent grade with the drawbar pull curve for 40 m.p.h. we find a rating of approximately 730 tons.

The maximum tonnage as given on the charts is that which the engine can start on a level straight track, assuming a starting resistance of 12 lb. per ton for freight trains.

The minimum speed shown on the charts is that equivalent

conditions or for drop in boiler pressure. In rating the locomotive a fixed percentage should be deducted from the maximum hauling capacity as given in these charts to suit local conditions.

CLEARANCE AND WEIGHT DIAGRAMS FOR STANDARD LOCOMOTIVES

For the purpose of presenting in a convenient manner the clearances of the standard locomotives of the Railroad Administration, F. P. Pfahler, chief mechanical engineer of

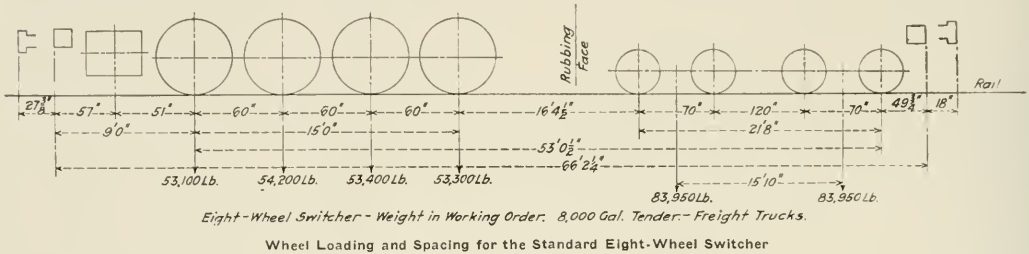

lent to 250 ft. piston speed per minute, the highest speed at which the locomotive will develop its maximum drawbar pull.

Table I gives the resistance in pounds per ton for varying

TABLE III—FRICTIONAL RESISTANCE OF PASSENGER CARS			
Speed, M. P. H.	Resistance, Lb. per ton	Speed, M. P. H.	Resistance, Lb. per ton
5	5.89	42.5	6.90
7.5	5.60	45	7.20
10	5.51	47.5	7.35
12.5	5.42	50	7.85
15	5.42	52.5	8.30
17.5	5.42	55	8.65
20	5.46	57.5	9.03
22.5	5.48	60	9.45
25	5.60	62.5	9.95
27.5	5.70	65	10.42
30	5.85	67.5	10.95
32.5	5.95	70	11.45
35	6.20	72.5	12.00
37.5	6.40	75	12.60
40	6.65	77.5	13.20
		80	13.85

weights of freight cars; this covers speeds from 5 to 30 m.p.h. and is based on the assumption that the resistance is constant between these limits.

Table II is taken from Bulletin No. 43 of the University

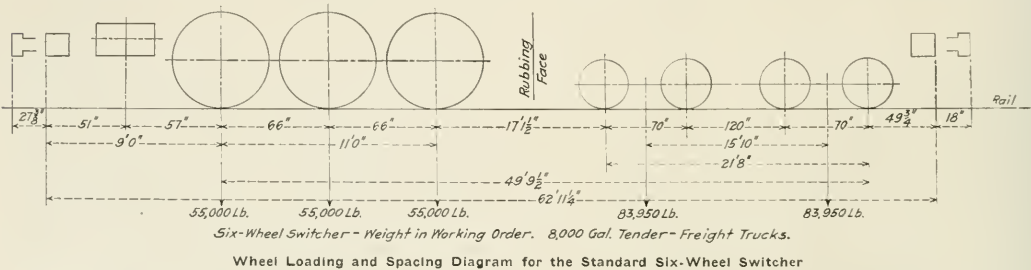

of Illinois, and represents tests by Prof. Edward C. Schmidt under actual service conditions. It will be observed that in this table the resistance per ton increases with the speed, and inversely, as the weight of the cars.

Table III gives the resistance for passenger cars at varying speeds. The data for Tables I and III are taken from Bulletin No. 1001, of the American Locomotive Company.

No allowance has been made for weather or temperature

the Division of Operation of the United States Railroad Administration, has prepared the diagrams shown in connection with this article. They are given for the light and heavy Mikados and the Eight-wheel and Six-wheel switchers and represent the correct diagrams for clearances and give the official distribution of weights of the different locomotives.

SPRAYING SURFACES WITH METAL.—The Zeitschrift für Angewandte Chemie describes a process for spraying metals on any kind of surface, using metal melted in an electric arc and blown by means of gas-jets on to the surface to be covered. The arc is produced between two electrodes, one being metallic, and a stream of non-oxidizing gas is directed on the electrode and portions of the melted electrode are carried away in the form of a fine spray, and may be deposited to form a metallic skin on any surface on which they impinge.

A NEW PROCESS OF TEMPERING STEEL.—The Swiss journal, Die Elektroindustrie, gives particulars of a process for removing the temper from hardened steel. The piece to be softened is placed on a plate of iron at red heat and covered by a plate of cold iron. After the whole has cooled,

the piece of steel, whatever was its previous quality and degree of hardness, is detempered completely, and can easily be worked without its quality having undergone any change by, for example, decarburization. The method is specially applicable to the unhardening of tools, more particularly punches and dies. Tests have given excellent results, and the method has the advantage that shaped pieces of steel do not show any shrinkage after treatment.



DESIGN OF SEVENTY-TON COAL CAR WITH TANDEM HOPPERS

A design for a 70-ton hopper car, the principal features of which are the arrangement of four pairs of inclined doors in tandem and a door operating and locking mechanism operated from either side of the car, has recently been developed and patented by Edward D. Hillman, secretary and engineer of the National Railway Appliance Company, New York. The main dimensions of the cars are:

Length inside	39 ft. 0 in.
Width inside	9 ft. 5½ in.
Height from rail to top of car	10 ft. 9 in.
Truck centers	30 ft. 0 in.
Distance over end sills	40 ft. 4 in.
Capacity	140,000 lb.

In the new design an increase in the cubical capacity of the car is obtained by building a series of four pairs of

and clevis attachments between the doors and the operating mechanism.

The operating mechanism combines a number of features which are unique in car construction. Two sets of doors are opened simultaneously at one operation and this can be accomplished from either side of the car. All coal cars of the hopper class on the railroads of the country today have their operating mechanisms located on one side of the car only and in dumping such cars on trestles, etc., much time is often consumed by the operator in passing back and forth when a number of cars are to be unloaded. Another feature is that the operator is secure against injury from a too quick opening of the doors. How these improvements have been brought about will be understood from a description of the mechanism.

Where the two-inch main shaft crosses underneath the space between the center sills it is formed into a "U" shaped

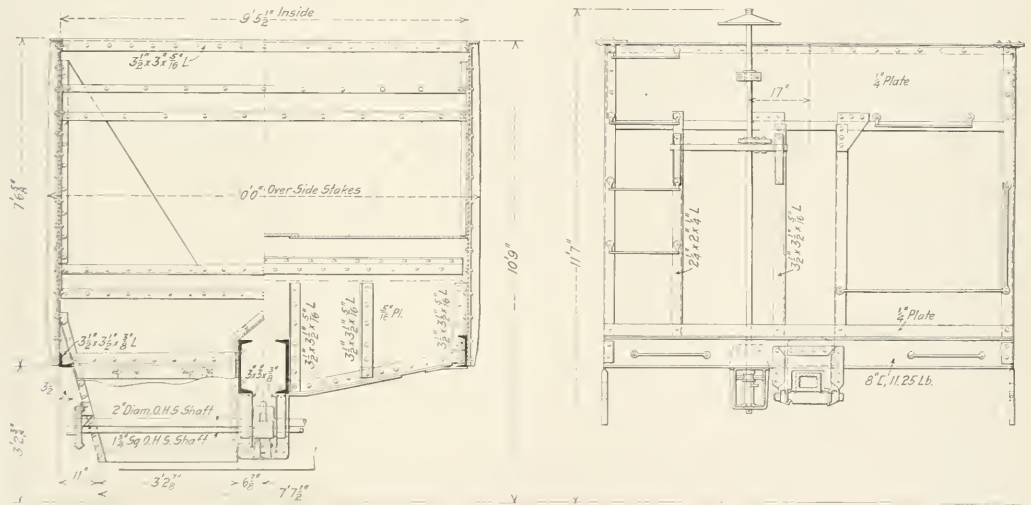

Cross Sections and End Elevation of the Hillman Hopper Car

hoppers beneath the sills. These hoppers are arranged in tandem, two pairs of hoppers being so constructed that one operating mechanism will open both pairs of doors simultaneously. This allows for the quick discharge of coal and half a car can be discharged at a time if desired. The discharge area of two pairs of doors is approximately 27 sq. ft., this insuring a rapid unloading of coal. The hopper arrangement below the sills increases the weight of coal at this point so that the center of gravity of the loaded car is considerably lowered. Eyebolts for adjustment have been eliminated and the adjusting feature is embodied in the link

link arm to which the main operating link is connected. The ends of this shaft are upset and formed to a two-inch square cross section. Ratchet wheels are attached to the squared ends, each wheel being provided with two teeth. Pawls engage the larger teeth of these wheels when the crank arm is in the locked position with main link over the center. These pawls pass by the center of the 1½-in. square auxiliary shaft, thus locking the pawls against any tendency toward movement away from the ratchet teeth.

Near the ends of the auxiliary shaft are carried small crank arm castings to which are attached the slotted ends of

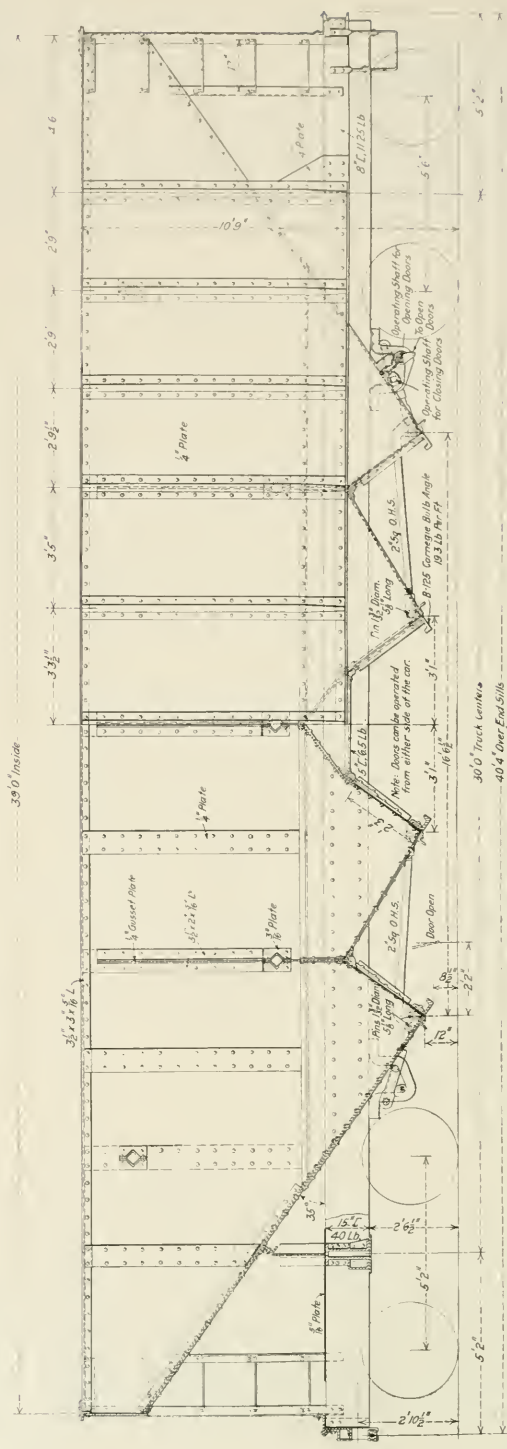
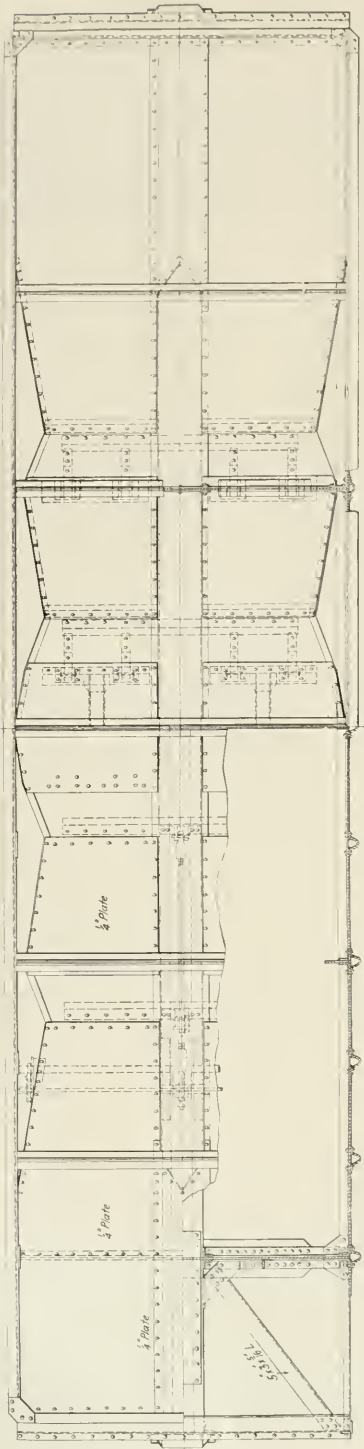

Hillman Seventy-Ton Coal Car with Two Sets of Tandem Hoppers

the pawls. Where the 1½-in. shaft passes through them these cranks are formed with two-inch square bosses which extend to the ends of the shaft, thus providing for the use of a single two-inch wrench on both the main and auxiliary shafts.

A cam is located on the auxiliary shaft between the sills so that it lies beneath the crank arm of the main shaft. This cam acts as a stop for the main shaft when the crank is in such a position that the line of action of the operating link has passed slightly by the center of the shaft. In the construction of this device forgings rather than castings have been used whenever possible.

With the doors closed the operator can turn but one shaft—the auxiliary—in but one direction, and this operation may be performed on either side of the car. As the auxiliary shaft is revolved, the pawls, passing from over the center, are disengaged from the ratchet wheel teeth on both sides of the car. As the disengagement of the ratchet is being completed the cam under the main shaft crank forces up the crank until it crosses the center, when the weight of coal on the doors forces them to open. The operator in the meantime having his wrench on the auxiliary shaft is in no way endangered.

To close the doors, the operator places the wrench on the

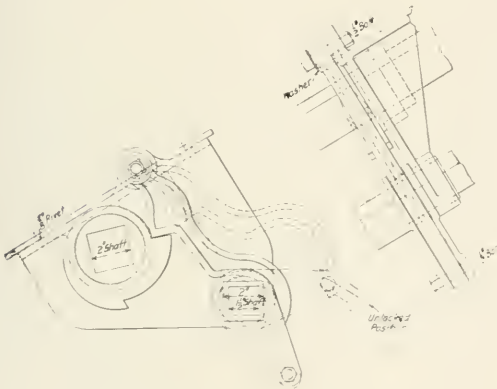

Hopper Door Operating and Locking Device

squared end of the main shaft and turns it till the crank arm passes over the center; this forces down the cam on the auxiliary shaft and causes the pawls to engage the teeth on the ratchet wheels. A slight turn with the wrench on the auxiliary shaft will then lock the pawls by bringing them over the shaft center.

The main members of the underframe are 15-in. 40-lb. channel center sills, with 3½-in. by 3½-in. by 3¼-in. angle side sills. The inside longitudinal hopper sheets are made in one piece for each set of hoppers flanged outwardly. Where each sheet passes up over the center sills the flange is riveted to that of the adjoining hopper sheet and the sheets are riveted to the sides of the center sills. Of the lower flanges one forms a surface against which the door closes, while the other acts as a support for the end hopper sheet. This sheet passes up over the hinge angle, giving the proper finish over the door of the next hopper.

The outside hopper sheets are made in one piece, the flanges performing the same functions as those on the inside sheets. At the top of these sheets they are riveted to the side sheet.

Patents have been applied for covering all the special details of construction of this car.

LIMIT OF COST FOR FREIGHT CAR REPAIRS

The division of operation of the Railroad Administration has issued Circular No. 20 relating to the repairs of freight cars. It is in general identical with the instructions issued by the Committee on Standards the latter part of July, which were published in the August issue on page 459. There are, however, a few interesting changes, and the entire circular is given in full below.

LIMIT OF COST FOR REPAIRS TO FREIGHT CARS BELONGING TO RAILROADS UNDER FEDERAL CONTROL

1. Freight cars in need of general repairs will be thoroughly inspected, all defective parts noted, and estimate made showing cost of repairs to place car in general good condition for two years' service barring accident and running repairs. Cars referred to in this circular are cars which are eligible for interchange under the MCB rules.

2. Limit of cost for making repairs to wooden freight cars which have not been rebuilt and improved by application of metal draft arms extending beyond body bolster, continuous steel draft arms, steel center sills, or steel underframe:—

(A) IN SERVICE 20 YEARS OR MORE—ALL FREIGHT CARS

	Limit of cost of repairs in kind, labor and material
If equipped with 40,000-lb. capacity trucks or less.....	\$25
Over 40,000-lb., but less than 60,000-lb. capacity.....	75
60,000-lb. capacity trucks and over.....	100

(B) CARS IN SERVICE 10 YEARS AND LESS THAN 20 YEARS

	Limit cost of repairs			
	In kind		With betterments	
	All cars except refrigerator	Refrigerator	All cars except refrigerator	Refrigerator
Equipped with 40,000-lb. capacity trucks or less.....	\$25	\$100	No betterments to be applied	No betterments to be applied
Over 40,000-lb., but less than 60,000-lb. capacity.....	100	150	\$1,000	\$1,200
60,000-lb. capacity and over.....	200	500		

3. Cars in service over five years and less than ten years and cars found equipped with metal draft arms extending beyond body bolster, continuous steel draft arms with transom draft gear or steel center sills or all steel underframe:—

All cars having trucks 60,000-lb. capacity and over will be repaired unless total cost of repairs, including cost of betterments, plus scrap value, exceeds 75 per cent of value of new car.

If cost of repairs exceeds 75 per cent of new car, it will be dismantled and good parts reclaimed for use in repairing cars of similar types. This will apply to existing equipment only.

4. Cars in Service Five Years and Less.—All cars having trucks 60,000-lb. capacity and over will be thoroughly repaired at cost necessary.

5. Cost of application of safety appliances, wheels, journal bearings, and couplers will not be considered in estimate cost of repairs.

6. All wooden freight cars with trucks 60,000-lb. capacity and over, receiving general repairs, not equipped with metal draft arms extending beyond body bolsters, steel draft arms extending full length of car, steel center sills, steel underframe or transom draft gear, will be equipped with either cast steel draft arms extending beyond body bolsters, steel draft arms extending full length of car, steel center sills or steel underframe. Cars equipped with steel underframes or steel center sills, will have continuous cover plates riveted to the top or bottom of sills, preferably to top.

7. When the cost of repairs in kind exceeds amount allotted to be expended, and betterments are not to be applied, the federal manager, or the general manager on roads having no federal manager, may authorize in writing that the car will be dismantled. Should cost of repairs in kind exceed the amount allotted, and betterments, described in rule 6, are to be applied; if material is not available, car may be sent to owners.

8. When cars are dismantled or sent home to owners for

rebuilding, a detailed statement will be made showing the estimated cost of repairs in kind, by item, and forwarded to owners, showing disposition, and copy retained by handling road.

9. To estimate detailed cost of repairs, add 35 per cent to the sum of applied labor and material.

BAD ORDER CAR SITUATION

A general summary of the bad order car situation taken from the reports of the railroads to the Division of Operation of the Railroad Administration for 10 weeks ending September 21, are interesting in that they show a steady decrease in the number of bad order cars. At the beginning of this period

classes by regions as of September 21 is shown in Table II. Box cars comprise 42.5 per cent of the total number, hopper cars 18.2 per cent, gondola cars 25.2 per cent, and the remaining classes all vary below four per cent. It will be seen from this table that the greatest bulk of the bad order box cars are in the Eastern and Northwestern regions. In the Northwestern region they comprise 60 per cent of the cars in bad order. In proportion to the number of cars in the Allegheny region the number of bad order hopper cars is, of course, high.

Referring again to Table I it will be noted that during the 10 weeks in question the number of employees in the car department increased from 134,615 to 146,004, with high weeks of over 150,000. This is an increase of about 14 per cent over the number of men employed a year ago at this time. It

TABLE I—TEN WEEKS' STATEMENT OF CAR CONDITION REPORTS

	Week ending—									
	July 20	July 27	Aug. 3	Aug. 10	Aug. 17	Aug. 24	Aug. 31	Sept. 7	Sept. 14	Sept. 21
Number of roads represented.....	158	158	143	143	143	143	143	140	139	139
Total revenue cars.....	2,474,787	2,503,828	2,492,749	2,494,408	2,480,792	2,484,381	2,493,145	2,407,758	2,493,730	2,493,074
Bad order cars.....	173,771	179,670	175,781	173,771	169,539	164,826	157,339	158,123	155,899	153,798
Heavy repairs.....	86,488	93,533	93,287	94,796	95,798	96,432	91,636	92,301	91,134	90,556
Light repairs.....	87,283	87,137	82,494	78,975	73,741	68,394	65,683	65,832	64,765	62,842
Percentage of bad order cars.....	7.0	7.1	7.1	6.9	6.8	6.6	6.3	6.6	6.2	6.2
Ave. B. O. cars repaired per working day.....	97,719	96,246	97,348	95,973	96,668	96,681	97,027	96,346	99,009	97,077
Heavy repairs.....	10,292	9,347	9,744	11,961	8,833	10,003	10,359	9,750	10,473	10,442
Light repairs.....	87,427	86,899	87,604	84,012	86,835	86,678	86,668	86,596	88,536	86,635
Number of cars transferred to other shops.....	346	215	459	290	1,363	1,750	1,862	2,188	2,501	1,791
Number of employees.....	134,615	137,360	138,659	140,308	142,895	146,677	150,042	150,006	145,141	146,004

there were 173,771 cars in bad order, or seven per cent of the total revenue cars on the roads then under the jurisdiction of the Railroad Administration, and on September 21 there were 153,798, or 6.2 per cent, a decrease of over 11 per cent. In order to increase the car supply it has been the practice on nearly every railroad to concentrate attention on bad order

cars. It is interesting to note that with this increase in the number of employees the average number of bad order cars repaired per working day has not kept pace with the increase in the number of employees, although for the week ending September 14 there was a high record of 99,009. The lowest number reported is for the week ending August 10, when 95,973 cars were repaired per working day with 140,308 employees.

TABLE II—CLASSIFICATION OF BAD ORDER CAR SITUATION AS OF SEPTEMBER 21, 1918, BY REGIONS

Class	East-ern	Alle-gheny	Poca-hontas	South-ern	West-ern	South-west-ern	North-west-ern	All regions
Box.....	20,912	9,986	1,247	5,570	8,272	3,526	15,449	64,942
Refrigerator.....	2,018	314	17	260	1,174	239	1,315	5,377
Stock.....	1,037	234	106	422	2,108	502	1,329	5,738
Hopper.....	12,418	9,960	1,324	1,454	457	402	1,917	27,932
Gondola.....	16,637	6,574	1,660	3,052	6,051	1,447	3,197	38,618
Flat.....	1,512	531	228	1,051	658	322	1,800	6,102
Coke.....	330	635	103	26	49	6	95	1,344
Miscellaneous.....	969	267	182	479	814	500	574	3,785
Total.....	55,833	28,501	4,867	12,394	19,583	6,944	25,676	153,798
Percentage B. O. cars.....	7.0	7.1	5.4	5.1	5.2	3.2	6.6	6.2

It is also interesting to note the number of cars that have been transferred from one road to another to reduce congestion. This has as a rule steadily increased, except that during the week ending September 21 a less number of cars was transferred than for the previous three weeks. It shows the improvement in co-ordination of the work.

A study of the more detailed freight car condition report for the week ending September 21, Table III, shows that during the week 26,411 cars were damaged in trains in the yards at a cost of \$427,710. While this number is a little over one per cent of the total revenue cars, an analysis shows that in the Central Western and Northwestern territory the number of cars damaged in this manner was about two per cent of the total number of revenue cars in that territory. In these regions there is considerable mountainous territory and it may be possible that the general air brake conditions of the cars are responsible for the proportionately large number of cars damaged in this manner.

cars requiring light repairs. This is reflected in Table I giving the summary of the conditions, the light bad order cars decreasing from 87,283 to 62,842. At the same time the heavy bad order cars have been kept well in hand.

The distribution of the bad order cars amongst the different

TABLE III—DETAILS OF THE BAD ORDER CAR SITUATION AS OF SEPTEMBER 21, 1918

	All regions				Poco-hontas		Central Western		South-western		North-western	
	Eastern	Allegheny	Poco-hontas	South-ern	Western	Allegheny	Western	South-western	North-western	Eastern	Allegheny	North-western
Number of railroads.....	42	15	3	24	20	20	20	18	17	17	17	17
Total revenue cars.....	789,811	398,935	88,866	242,743	372,349	12,394	19,583	6,944	25,676	2,493,074	153,798	153,798
Total bad order cars.....	58,833	27,346	5,960	14,442	14,442	14,442	14,442	14,442	14,442	14,442	14,442	14,442
Heavy.....	30,956	20,772	3,125	7,012	7,012	7,012	7,012	7,012	7,012	7,012	7,012	7,012
Light.....	27,877	6,614	2,835	7,430	7,430	7,430	7,430	7,430	7,430	7,430	7,430	7,430
Percentage of bad order to revenue cars.....	7.4	6.9	6.7	5.9	3.9	3.9	3.9	3.9	3.9	3.9	3.9	3.9
Railroads having four per cent bad order or less.....	61	9	2	12	12	12	12	12	12	12	12	12
Railroads having more than four per cent bad order.....	19,695	2,899	1,832	2,68	938	6,394	87,050	6,504	14,200	19,695	2,899	1,832
Number of cars damaged in trains.....	121,056	52,758	19,378	3,643	15,097	33,791	33,791	33,791	33,791	33,791	33,791	33,791
(Labor.....)	\$121,056	\$27,528	\$19,378	\$3,643	\$15,097	\$33,791	\$33,791	\$33,791	\$33,791	\$33,791	\$33,791	\$33,791
(Material.....)	\$163,827	\$41,445	\$27,346	\$5,960	\$24,471	\$44,363	\$44,363	\$44,363	\$44,363	\$44,363	\$44,363	\$44,363
Cost of repairs.....	6,716	2,099	1,043	105	404	584	1,609	762	1,609	762	1,609	762
Number of cars damaged in yards.....	858,570	519,614	111,355	22,190	55,556	66,578	66,578	66,578	66,578	66,578	66,578	66,578
(Labor.....)	\$858,570	\$27,533	\$16,442	\$3,990	\$9,220	\$17,234	\$17,234	\$17,234	\$17,234	\$17,234	\$17,234	\$17,234
(Material.....)	\$28,258	\$27,533	\$16,442	\$3,990	\$9,220	\$17,234	\$17,234	\$17,234	\$17,234	\$17,234	\$17,234	\$17,234
Average number bad order cars repaired each working day.....	97,077	29,741	10,888	4,507	7,334	7,334	7,334	7,334	7,334	7,334	7,334	7,334
Heavy.....	10,442	2,843	820	274	205	2184	857	2,259	2,259	2,259	2,259	2,259
Light.....	86,635	26,908	10,068	4,233	6,029	10,538	9,930	18,939	18,939	18,939	18,939	18,939
Total number cars remaining to be repaired in contract shops.....	11,644	7,750	1,699	2,092	0	110	0	88	88	88	88	88
Total number cars in contract shops undergoing and awaiting repairs.....	4,267	2,652	421	392	532	128	0	142	142	142	142	142
Number of cars transferred from one road to another to help reduce bad orders.....	1,791	1,312	163	100	216	0	0	0	0	0	0	0
Total number of employees.....	146,004	41,294	19,532	5,227	18,915	25,453	13,403	22,180	22,180	22,180	22,180	22,180
Net total increase during the week.....	1,170	648	6	6	6	6	6	6	6	6	6	6
Total number of employees for same week of last year.....	128,457	35,715	15,904	4,948	17,241	22,182	14,466	17,998	17,998	17,998	17,998	17,998

CAR DEPARTMENT OF THE MILWAUKEE

Organization and Methods of Handling Light and Heavy Car Repairs with Samples of the Forms Used

WITH the reorganization of the mechanical department of the Chicago, Milwaukee & St. Paul a well founded and complete organization has been established in the car department. The master car builder who reports directly to the general superintendent of motive power has complete charge of all car construction and maintenance matters and all line officers in the mechanical department, whether on the car or locomotive side, report directly to him or his staff on all car problems. The plan of organization is well illustrated by the chart shown in Fig. 1. It will be noted that the plan has been to divide the entire road which covers a territory of 11,000 miles into four districts. The main car shops at Milwaukee, at which a large amount of new work is done, is directly in charge of five general foremen who report to the master car builder's office as do the heads of subsidiary departments,

entire time to the Dubuque shops, which employ 1,000 men. The general foreman at Seattle, Wash., covers repair points at Cedar Falls, Cle Elum, Everett, Bellingham, Kapowsin, Mineral, Hoquiam, Raymond, Port Angeles and Seattle.

CLASSIFIED REPAIRS

There are four main car shops on the system, located at Milwaukee, Wis., Dubuque, Iowa, Minneapolis, Minn., and Tacoma, Wash., respectively. At these points classified repairs to both passenger and freight equipment are made.

Classification of Freight Car Repairs.—All system freight cars brought into the shops are assigned to one of five different classes. Class A involves the rebuilding of a car or repairs the expense of which exceeds 50 per cent of the total value of the car, and cars requiring between 60 and 100 hours of labor and from \$175 to \$540 worth of material.

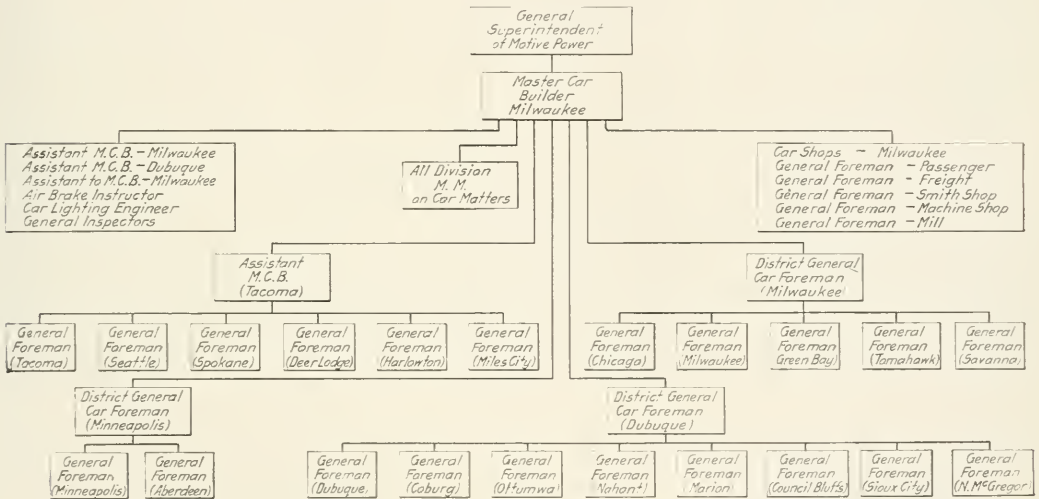

Fig. 1—Organization Chart of the Car Department of the Chicago, Milwaukee & St. Paul

such as the air brake instruction and inspection departments and the car lighting department.

To assist in handling the duties of this office there are on the staff of the master car builder two assistant master car builders who handle committee work in the M. C. B. Association and the American Railway Association and one assistant to the master car builder who handles all of the routine work of the car department. Each district officer has a complete office force in charge of a chief clerk and the manner in which all business is handled has been standardized to agree with the practice followed in the general office at Milwaukee. The districts are further subdivided as indicated in the chart, and placed in charge of general car foremen who are required to visit every shop or repair point under their jurisdiction once every two weeks. The territory covered by these general foremen depends upon the amount of work handled at the different points and the availability of those points to the headquarters of the general foreman. For instance, the general foreman at Dubuque, Iowa, devotes his

Class B, or heavy repairs, includes cars that are seriously damaged or decayed and involves from 30 to 60 hours of labor with \$100 to \$150 for material. Class C, or medium repairs, includes a general overhauling to the cars, involving from 20 to 30 hours of labor and an expenditure of from \$50 to \$85 for materials. Class D, or light repairs, includes a normal overhauling and the application of couplers, wheels, bolsters and posts, or safety appliances, involving from 10 to 20 hours of labor and an expenditure for material of from \$15 to \$55. The class E, or running repairs, includes repairs made in train yards or repair tracks and involves the application of nuts, cotters, bolts, grab irons, bearings, air hose, train line, brake shaft or any other repairs which are necessary to make the car safe for handling and can be accomplished in the time specified. This involves labor of 10 hours or less.

When the system cars are received on the repair tracks they are examined by inspectors who fill out the form shown in Fig. 2, for cars requiring class A, B or C repairs and the

Running boards are to be continuous from end to end and not cut out or hinged at any point; provided, that the length and width of running boards may be made up of a number of pieces securely fastened to saddle blocks with bolts or screws. The ends of longitudinal running boards shall be not less than 6, nor more than 10 in. from a vertical plane, parallel with end of car and passing through inside face of knuckle when closed with coupler horn against the buffer block or end sill, and if more than four inches from the edge of the roof of the car, shall be securely supported their full width by substantial metal braces.

Running boards shall be made of wood and securely fastened to car by bolts or screws.

The subject of loss and damage due to defective equipment is also given very careful consideration. Frequently statements are made showing the number of claims made in each district for certain periods of time as between system and foreign cars, the total amount of damage, the average cost per claim and the average number of defective cars per day. The matter is simply put out for the information of the various district general foremen and gives a comparison of the various districts. It gives the men an idea as to the extent of the damages occurring in their district and just what it means in dollars and cents, giving them an incentive to improve conditions.

The car department has in its organization a traveling air brake instructor whose sole duty is to follow up the air brake work on both freight and passenger cars. There are two instructors who look after the accounting office systems for the various repair points and shops with the idea of unifying and standardizing this work all over the road. The billing repair cards are made out in the office of the general car foreman and not at the small repair points. It has been found that this results in considerable saving and the records are easily obtained.

Every effort is made to keep the premises around all repair points as neat as possible and the company has even gone so far as to discharge men who persist in neglecting this matter, as it is believed that if the premises present a neat appearance greater efficiency will be obtained.

STANDARDIZING PAINTING AND STENCILING

BY J. H. PITARD

Foreman Painter, Mobile & Ohio, Whistler, Ala.

Since the railroads have come under government control and their operation conducted on the unit plan many advantages are gained by the changes being made in the various methods of operation. Some of the changes to a minor extent have reached the painting end of the freight repair yard, but thus far these changes in their broader scope and possibilities for effecting economy in the painting and stenciling of freight equipment are practically untouched. This implies the advisability of adopting a standardized system of painting and stenciling all cars under government control, regardless of previous practice in this particular.

To maintain the individual coloring and marking of cars of the various roads passing through the various freight yards where they are now required by federal order to be repainted and stenciled as conditions require, would result in an enormous increase in the amount of stencil making and stenciling with probable detention of cars, to say nothing of the costly increase in the variety and quantity of paint material necessary to be carried in stock in order to meet the emergency conditions.

The item of stencil cutting alone can well be imagined when it is considered that no two roads of the country have identically the same markings and many roads, strange to say, have no standard for stenciling their own cars, and yet such cars must frequently be repainted and stenciled in foreign yards whenever repairs or the perished condition of the paint renders it necessary to do so. When an

unusual number of such cars appears in the repair yard simultaneously, it will in many instances probably result in the detention of such cars until the stencil cutting can be completed, unless there is a considerable increase in the stencil cutting force, which in either case means an increase in the cost of handling the situation that might be obviated by the adoption of a standardized plan of procedure.

Proceeding on the standardized plan, the original name of all roads could be maintained with lettering of the same style and size, likewise a smaller letter for expressing the equipments, dimensions, capacity, etc. Next, but not least in importance is the necessity for standardizing the color for freight equipment. At present the colors used are legion and while no particular color has any calculable superior commercial or advertising value, they represent an increased cost at the various freight yards on account of the constant matching of colors, changing of brushes and outfits from one color to another. For a standard color for freight cars there is perhaps none that would give better general satisfaction than the iron oxide, or so-called mineral brown very generally used by the roads of the country. It is not monopolized and is to be found in various sections of the country.

There is, however, one exception that should be made in standardizing on a freight car color and that is in the case of painting all refrigerator cars. For that purpose a very light color should be selected, as it is a well known fact that very light colors are the coolest for the physical reason that such colors reflect the heat, whereas very dark colors absorb it.

Of course it is difficult to even approximate the amount to be saved under a standardized plan of painting and stenciling all cars under federal control, but when it is considered how much it would simplify and expedite the operation, it is reasonable to suppose that the result would fully justify the change.

CAR DEPARTMENT ORDERS

During the past month the following orders were issued by the Railroad Administration relating to car maintenance problems:

MAINTENANCE OF AIR BRAKES ON FREIGHT CARS

In Order 99 the Southwestern regional director states that the general condition of air brakes on freight cars is such as to require immediate and continued careful attention. The following instructions are effective at once:

1. After the air brakes are cleaned and tested the air pipe should be properly fastened in place to prevent the rattling and breaking of joints and all leaks made tight.
2. Trains made up in transportation yards should have the brakes tested and all leaks remedied before departure. This should also be done on all cars passing over shop tracks.
3. Railroads should endeavor to clean, test and put in good condition, all automatic brake equipment on freight cars. The number of brakes thus repaired each month should be equal to at least one-tenth of the equipment owned by that road.
4. Federal managers should see to it that a record is maintained by the mechanical department to show the amount of this work that is done, and be prepared to make complete reports to the office of the regional director upon request.

CARE OF JOURNAL BOXES

The Mechanical Department has issued Circular No. 4 as follows:

1. It is desired that all freight car journal boxes be repacked with properly prepared packing at least once every 12 months, at which time all packing will be removed from the boxes and the boxes cleaned; dust guards to be renewed when wheels are changed.
2. The date and place where the work is done must be stenciled on the car body in one-inch figures and letters, using the same station initial that is used for air brake stencil.
3. This work to be done as far as possible when cars are on repair track undergoing heavy repairs. When on repair track for heavy repairs, cars which have not had boxes repacked within nine months will have all boxes repacked and the records stenciled on the cars as above.
4. This does not contemplate any change in the intermediate packing of boxes when it is necessary to do so. No change should be made in the stenciling unless all boxes are repacked.



SHOP PRACTICE



LOCOMOTIVE SUPERHEATER MAINTENANCE*

A superheater is as strong or as serviceable as its weakest unit. A poorly ground ball joint, or a pipe repaired with a piece of butt-welded tubing, is only as durable as the imperfect repair job. Repairs of which these are illustrations are frequently the cause of serious and extended annoyance from equipment in service. There are correct methods of maintenance and they are always cheapest in the long run.

After a unit is completely assembled at the factory the ball ends are carefully ground so that a bearing from 1/32 in. to 3/32 in. wide is obtained entirely around the ball to insure a tight joint when it seats in the header. The ends of the unit

and the header, the most satisfactory method is the soft-metal grinding process. This process is both simple and cheap. A grinding cup of lead or hard babbitt metal is used for the unit end and a ball 2 1/8 in. in diameter, and of the same metal, for the seat in the header. These are used with powdered carborundum to obtain the line bearing, and when the cups and balls commence to lose their contour they can be melted and used over again. The mold for forming the cups and spheres is shown in Fig. 3. It consists of three parts—the base in which the cup grinder is cast, the base in which the spherical grinder is cast, and the top part of the mold which may be used with either base. A chuck is shown in Fig. 4 which will hold either the cup or the spherical grinder, the chuck having a shank suitable for use in an air motor.

The use of these molds renders practical the production, at a nominal cost, of grinding forms which are accurate in contour, by all terminals regardless of their mechanical equipment. There is practically no waste of material as the material can be used repeatedly.

Excessive grinding will not produce a seat that will

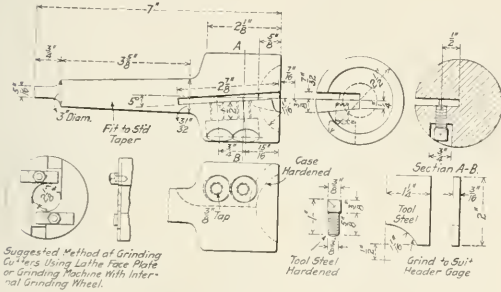

Suggested Method of Grinding Cup's Using Lathe Face Plate on Grinding Machine With Internal Grinding Wheel.

Fig. 1—Tool for Facing the Ball Ends of Superheater Units

are then protected by a wooden block, bolted in place. When a superheater has to be removed from a locomotive during repairs the unit ends should be protected by blocks in this manner, as otherwise the seats will be damaged. This will necessitate more work in order to get a satisfactory finish on the ball end. In refacing the seats on the unit ends, care should be taken to retain the spherical shape with a radius of 1-1/16 in. Great care should be exercised not to remove too much metal when truing up the seats. Unless a unit has been damaged so that it is grooved or cut, there is no need of finishing the end with a cutting tool as a light grinding is usually sufficient. The Draper cutting tool with the offset shank should not be used for this work, as in the hands of the average man it almost invariably results in destroying the spherical contour of the seat and there is consequently an imperfect joint made with the seat in the header. A satisfactory tool for this work is shown in Fig. 1.

The seat in the header for the ball end of the unit is not made spherical, but is a bevel seat with an angle of 45 deg., and can be trued up by means of a 45 deg. reamer, Fig. 2. Here, again, it is seldom necessary to take more than a very light cut. Great care should be exercised when the reamer is used with an air motor to prevent damage by removing the seat too much.

For obtaining the final line bearing on both the unit end

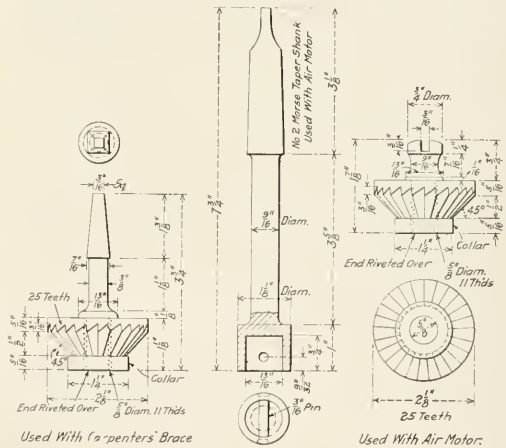

Fig. 2—Reamers for Superheater Header Seats

make a tight joint, but will only result in wearing the seat out of true. A light grinding that will produce a good line bearing, from 1/32 in. to 3/32 in. wide is sufficient.

LEAKING UNIT JOINTS

Leaking unit joints at the header should be stopped by tightening the clamp bolt nuts, *taking care not to stretch the bolts*. If this will not tighten the joint, remove the nuts on the clamp bolt, drop the clamp and slide the unit out so as to get at the joints. If the seats are not badly cut, clean the joints and grind with the soft metal grinding tools.

It is recommended that both parts of the joints, when

*Taken from Bulletin No. 4 (Copyright, 1918) of the Locomotive Superheater Company.

finished, be tested with a gage having convex and concave surfaces, of 1-1/16 in. radius, before replacing the unit. Prussian blue should be used for this test, as it is finer than the red lead or lamp black ordinarily used and will show defects in the joints more plainly.

The ball part of the joint should show a continuous blue surface over the ball when tested with the concave seat in the test gage. The conical seat in the header should show a

If the work of grinding is properly done their use will not be necessary.

TESTING

After all the units are in place, but before the second unit bolt nut or the steam pipes are applied, blank the steam pipe connections on the header and apply water test, to include the boiler, with a pressure at or above the working pressure of the boiler. Inspect all connections and stop all leaks that may appear. After the boiler has been steamed up, test the superheater with steam and try to tighten all the unit bolt nuts, after which the second nuts may be applied and set up tight.

For good service, all unit bolts should be gone over after

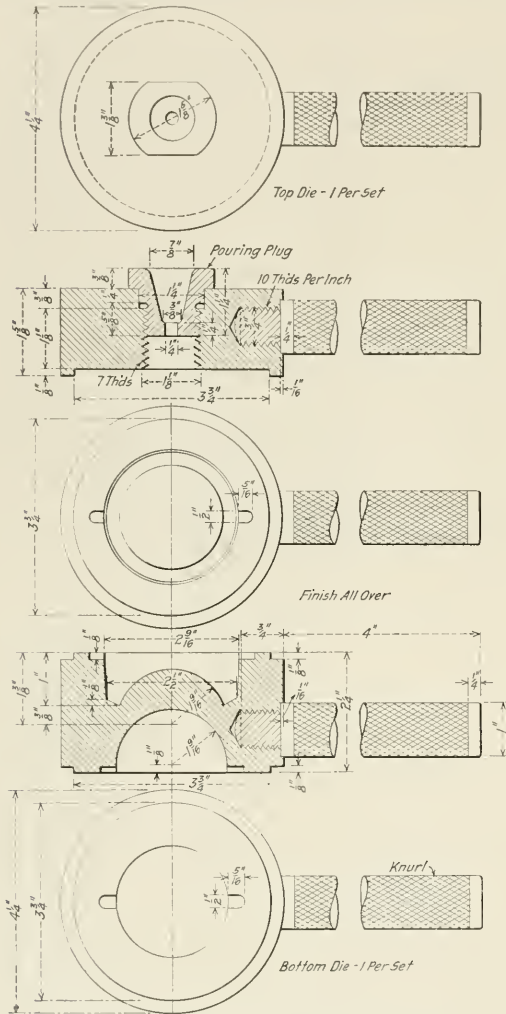

Fig. 3—Mold and Holder for Soft Metal Grinders

continuous blue line when it is tested with the ball end of the gage.

Ball joints in seats which have been damaged by steam cuts or mechanical injury should be brought back to the standard of new work, i.e., a 45 deg. bevel seat in the header, and a spherical surface of 1-1/16 in. radius for the ball end on the unit.

Varnish, red lead, plumbago, or other compounds, should not be used on unit ends or header seats in making joints.

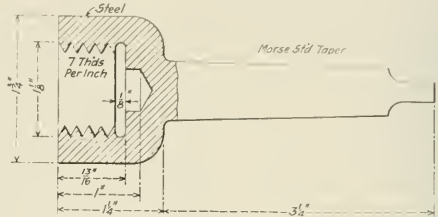

Fig. 4—Chuck for Holding the Cup or Spherical Grinder

the engine has made two or three trips, and any slack that may have developed in the bolts taken up.

BOLTS, WASHERS AND CLAMPS

The clamps and washers which, with the unit clamp bolts, hold the units in place against the header, are made of steel, and cast iron or other substitutes should never be used. In order to prevent the stretching of unit clamp bolts, and consequent leaking of the joints at the header, these bolts are made of heat-treated steel with a tensile strength of

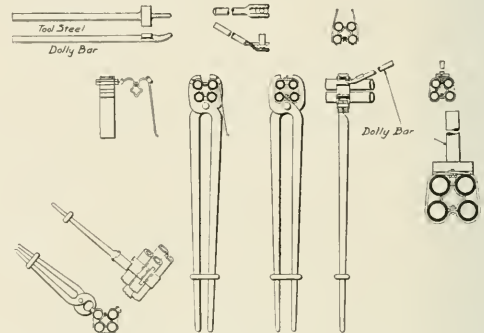

Fig. 5—Tools for Applying Bands and Supports for Superheater Unit Pipes

100,000 lb. per sq. in. and an elastic limit of 75,000 lb. per sq. in. Ordinary bolts, of low tensile strength, are not satisfactory for this work.

UNIT PROTECTING SHIELDS

The cinders formed by the coal in use in some localities have a cutting action on the upturned ends of the unit pipes in the smokebox. This wear, if allowed to continue, may cause holes in the pipe. Where such wear takes place it can be guarded against by applying shields. The shields for the pipes are formed of 1/16 in. steel and are held in place by bending them around the unit pipes.

MAINTAINING BANDS AND SUPPORTS

If the unit pipes are not held in place so that they will always maintain the same position in relation to each other and the flue, the unit will vibrate in the flue, not only causing wear on the flue and the unit, but also tending to break the joint between the unit pipe and the header and permit steam to escape into the smokebox. The bands and supports, therefore, should always be carefully applied whenever it is necessary to do so in the course of making repairs. Confusion sometimes exists as to the difference between bands and supports. The bands are provided with a center filling or spacing piece for the four unit pipes, and the band proper is riveted to this and finally the two ends are riveted together around the pipes. The supports, while acting as bands, have in addition two pieces of square cross section, which rest on the flue and support the unit. These pieces should be slightly rounded on the ends to prevent their cutting into the flue during expansion and contraction.

For units less than 136 in. long, one support is required for each unit. For units over 136 in. long two or more supports are required for each unit. One band is required for each unit, in addition to the supports. The tools and method of applying bands and supports are shown in Fig. 5.

The proper application of bands and supports is of the utmost importance. The pipes should be firmly held together at all times and unless the bands and supports are properly applied, the pipes will vibrate in the flue. Furthermore, if bands are used where supports should be, the unit will rest on the flue so that the bottom pipes will not have the proper contact with the hot gases and the cinders and soot will have much greater opportunity to collect and block the flue, with the consequent impairing of the superheater's efficiency. In welding superheater flues, care is needed to prevent a reduction of the internal diameter as this may make it impossible to insert the superheater unit in the flue after the bands and supports are applied.

INTERPRETATION OF ORDER INCREASING WAGES OF SHOP EMPLOYEES

Director General McAdoo has issued the following interpretation No. 3 to General Order No. 27, and to Supplement No. 4, Addenda Nos. 1 and 2, Interpretation No. 1 and Amendment No. 1 thereto:

METHOD OF APPLYING INCREASES TO PIECEWORKERS.

ARTICLE I.

(a) The increases provided for in General Order No. 27 apply to each hour worked and not to piecework prices per item or operation.

(b) Overtime hours, prior to August 1, 1918, will be paid for at the rate in effect as of December 31, 1917, and up to and including July 31, 1918; from August 1, 1918, at the rate of one and one-half times the average straight time hourly piecework earnings for the current pay period, provided that the straight time piecework earnings plus one-half additional equals the guaranteed minimum at the hourly rate of one and one-half time.

(c) Any increase in wages due to increased rates of compensation granted between January 1, 1916, and December 31, 1917, shall be deducted from the amount of increase provided for in General Order No. 27, but in no case shall such deduction operate to reduce earnings based on rates in effect as of December 31, 1917.

(d) In the absence of established standard hourly rates for any one or more of the seven classifications designated in Supplement No. 4, the going rate in each craft in accordance with the classification existing prior to the application of Supplement No. 4 for mechanics or helpers at each point on each of the several railroads, shall be used as the base rate to which will be added the increases provided for in Section C, Article II, General Order No. 27.

(e) Example 1.—Assume that in Yard B, 75 wood freight car builders or repairers are employed, the base hourly rates in December, 1915, were:

- 15 at 32 cents per hour.
- 31 at 33 cents per hour.
- 17 at 34½ cents per hour.
- 12 at 36 cents per hour.

Thirty-three cents thus becomes the going rate for the basis of computing the hourly increase for all wood freight car builders or repairers in Yard B. General Order No. 27, Article II, Section C, using the going rate of 33 cents, establishes a rate of 46.75 or 13.75 cents increase over the December, 1915, hourly rate. Between January 1, 1916, and December

31, 1917, increases amounting to 9 cents per hour had been put into effect. The net increase established by General Order No. 27 is therefore 4.75 cents per hour to hourly workers, and represents the total increase per hour to pieceworkers of the same class in Yard B. The same method of procedure will apply to each of the respective groups of employees, such as upholsterers, coach carpenters, cabinetmakers, passenger or freight steel car body builders or repairers, truck builders or repairers, coach painters, locomotive painters, locomotive carpenters, molders, coremakers, electricians, signal men and signal maintainers, tinners, pipe fitters, cooper-smiths, sheet metal workers, and all men classified and used as helpers.

(f) Where piecework rates or pieceworkers received no increase between January 1, 1916, and December 31, 1917, it is evident that the average earning rate was sufficiently in excess of the hourly rate to cover any increases that may have been granted hourly workers. In determining the increase to such pieceworkers, they shall receive the same increase per hour as accrues to the hourly worker under General Order No. 27, illustrated herein by example 1, paragraph e.

(g) The application of increases to machinists, boiler-makers and blacksmiths, who are on the piecework basis, shall be as above outlined (see example 2) except where the establishment of the minimum rate of 55 cents per hour is less than the increase provided for in Section C, Article II, General Order No. 27, in which case the greater increase will apply. (See example 3.)

(h) Example 2.—In December, 1915, machinists in Shop C were paid a going rate of 35 cents per hour. Section C, Article II, General Order No. 27, establishes a rate of 49.50 cents per hour. This would automatically go to the minimum rate of 55 cents per hour, or 20 cents increase over the December, 1915, hourly rate. Between January 1, 1916, and December 31, 1917, increases amounting to 9 cents per hour had been put into effect. The net increase established by General Order No. 27 is therefore 11 cents per hour to hourly workers and represents the total increase per hour to the machinists on piecework in Shop C.

(i) Example 3.—In December, 1915, machinists in Shop D were paid a going rate of 42 cents per hour. The new rate provided for in Section C, Article II, General Order No. 27, is 58.25 cents per hour, making an increase of 16.25 cents per hour over the December, 1915, hourly rate. Between January 1, 1916, and December 31, 1917, increases amounting to 9 cents per hour had been put into effect. The net increase established by General Order No. 27 is therefore 7.25 cents per hour to hourly workers, and represents the total increase per hour to the machinists on piecework in Shop D.

(j) If the increases for pieceworkers under General Order No. 27, added to their average hourly straight time piecework earnings, by pay period, do not equal the minimum hourly rates established for hourly workers of the same class, the back pay due such pieceworkers, by pay periods, January 1, 1918, to July 31, 1918, inclusive, will be computed on the basis of the minimum hourly rates applicable to the respective classes, as per Supplement No. 4.

(k) Example 5.—Pieceworker F, guaranteed a 58 cent minimum hourly rate by Supplement 4, worked 208 straight time hours in March, 1918; his average piecework earnings for this pay period were 55 cents per hour, including the increase under General Order No. 27. Pieceworker E therefore receives the minimum rate of 58 cents per hour for the March pay period.

(l) Example 5.—Pieceworker F, guaranteed a 58 cents minimum hourly rate by Supplement 4, worked 208 straight time hours in March, 1918; his average piecework earnings for this pay period equals 60 cents per hour, including the increase under General Order No. 27. Pieceworker F, having exceeded the minimum rate of 58 cents per hour for the March pay period, receives back pay at the 60 cent rate.

(m) Example 6.—Pieceworker G, guaranteed a 58 cent minimum hourly rate by Supplement 4, worked a total of 268 hours in August, 1918, divided as follows: 50 straight time hours on hourly work at 58 cent rate, 158 straight time hours on piecework, average earnings per hour 65 cents, 20 hours overtime on hourly work at the rate of one and one-half time, or 58 plus 29, equaling 87 cents per hour, and 40 hours overtime on piecework, or 65 plus 32.50, equaling 97.50 cents per hour (as per Art. II, Sec. A), the total earnings for the August pay period are as follows:

50 hours at 58 cents per hour.....	\$ 29.00
158 hours at 65 cents per hour.....	102.70
20 hours at 87 cents per hour.....	17.40
40 hours at 97.50 cents per hour.....	39.00
Total	\$188.10

GENERAL APPLICATION OF INCREASES, SUPPLEMENT 4 TO GENERAL ORDER 27.

ARTICLE II.

(a) The increases provided for in Supplement No. 4 to General Order No. 27 apply only to hourly, daily, weekly or monthly rates, with the proviso that in no case shall a pieceworker be compensated for service rendered from January 1, 1918, to July 31, 1918, or thereafter, at a less rate per hour, for each straight time hour worked, than the minimum rate established for the hourly worker as per the respective classifications. Effective August 1, 1918, the one and one-half time rate overtime applies to pieceworkers as well as to hourly rated employees.

(b) Increase provided for in General Order No. 27 for hourly, daily, weekly and monthly paid employees, were cancelled with the issuance of Supplement No. 4, and in no manner refer to or affect the increases provided for in Supplement No. 4 to General Order No. 27.

(c) The hours of service and overtime provisions of Supplement 4, Article IV, Section 2, do not apply to supervisory forces on monthly salary, referred to in Supplement 4, Article III, Section 5.

(d) Monthly supervisory forces specified in Supplement 4, Article III, Section 5, assigned to inspect new equipment under construction by contract, shall receive the salary increase of \$40 per month.

(e) Excepting salaried supervisory forces and coach cleaners, employees coming within the classifications specified in Supplement No. 4 to General

WHEN THE "OLD MAN" SHOWED HIS "PEP"

The Difference Between "New Blood" on Some Railways and "New Blood" in the Industrial Field

BY HARVEY DEWITT WOLCOMB

THE "Old Man" was on the war path. The news spread quickly through the shop by that indescribable method common to all shops where a large number of men are employed. It wasn't gossip, neither was it a thing of conversation—it was just a little warning to keep out of his path, for woe to the man who invited a call down when the "Old Man" was off temper. This particular morning, as he walked down through the shop with eyes straight to the front, looking neither to the right nor left, a stranger would have said that apparently he was not interested in what was going on. Entirely to the contrary, he was very much interested indeed, and while he did not as much as wink an eye, he did, however, take in all that was going on around him.

Dan Keefe—commonly spoken of behind his back as the "Old Man"—was a thorough mechanic educated in the hard school of practical experience. He had been master mechanic of the big terminal at Wonderly on the R. S. & P. for so many years that he knew every nail in the building. He was a good manager and had established many records that few shops of equal size could duplicate. This had not, however, turned his head, for he was one of the finest chaps in the world to visit, but when it came to business he was an entirely different man.

It had been some time since he had had a spell of being on the war path and as everything was going along smoothly, Jim Booth, the general foreman, was at a loss to know what had caused the present trouble. He was to be enlightened very shortly.

Going straight to his office, the "Old Man" sent the office boy out for the general foreman. You can imagine how poor Jim Booth felt. From past experience he knew he was to get the devil no matter whether he was in the wrong or not. Someone had to be the "goat," and on many previous occasions the general foreman had been that animal. But then, as this is part of the railroad routine, he made up his mind to take his medicine like a man.

Much to his surprise, when he entered the private office the master mechanic greeted him with a cheery "good morning." Pointing to a letter on his desk, he boastfully said, "Well, Jim, we beat them at their own game. You remember about a month ago the superintendent had two inspectors down here, and after they 'gum-shoed' all over the place the only thing they could criticize us about was the new store shed we built behind the roundhouse. The superintendent wrote me a nasty letter about that and as much as said if I couldn't satisfactorily explain why this shed was built, I might as well look for another job. That made me sore, for these two inspectors didn't know as much about the many little details of this place as a setting hen. They simply came down here

a few days, skimmed over the surface and then made their report."

"We had authority for that shed," broke in Jim.

"Oh, yes," he replied, "proper authority had been granted to construct a shed and the M. of W. department was to build it, but after waiting over a year for them to make up their mind we went ahead and built it ourselves. That's the only way you can accomplish anything on a railroad—do it yourself and you know it's done. But here is the joke of the whole thing. Those inspectors didn't know that that common looking shed was really a complete auxiliary power plant. You know, Jim, when we built that shed, we put in two concrete pits, connected up the sewer, ran a six-inch steam line

through the building and tapped our main water supply line. Last winter when all the other plants were tied up for steam we simply ran two locomotives in that shed and in less than an hour we had a complete power plant in operation. Our men had protection from the severe weather, our engines did not freeze up, and everything was so conveniently arranged that it did not cost us much money to take care of the extra requirements. While the other fellows were running around trying to make temporary arrangements to furnish steam to take care of the extremely cold weather, I was wiring the superintendent that we had plenty of steam and everything was O. K. In other words, we had foresight."

"Yes, I know that deal last winter always did bother the superintendent. You remember, he cornered me one day down in the shop and asked me all about how we managed to come through so well, but I was ready for him and told him then just what you had advised me to say."

"You did just what was proper, and now, my boy, I want to tell you something. You have been general foreman for me here at Wonderly for nine years. I have held on to you and have refused to let you be transferred or promoted many different times, but I can see that my selfish motives were not fair to you, so am going to recommend you for the job as master mechanic at Johnson's Landing. They need a good man there and with your long training, I know you will make good."

Dumbfounded, poor Jim Booth didn't know what to say. He had been at Wonderly so long that the place seemed like home to him and away down in his heart it nearly made him sick to think of starting out anew. At Wonderly he knew every man, knew just how to handle them. His family had their friends, he held office in one or two of the lodges of which he was a member, and—to tell the truth—Jim Booth didn't welcome the thought of a change. But he knew the

THIS story, drawn from real life, carries a moral, the force of which will be apparent to many of our readers. Positions filled through nepotism or "a pull" are seldom, if ever, properly administered. There is no easier method of breaking up the esprit de corps than to disregard the value and the real worth of the men by side-tracking them for somebody's friends. Even the men in the ranks will buck such a procedure. There are hundreds of thoroughly seasoned men in the railway mechanical departments today who would make able and desirable supervising officers. Smoke them out—develop them—make the supervising positions attractive to them. Don't let the industrials get the cream. An able executive is as valuable to the railways as to any other industry.

"Old Man" thought a great deal of him and if he said "Go," then go it was.

This sudden and unexpected news of being promoted so excited Jim that he excused himself and returned to the shop. Although he said not a word to any one in the plant about the conversation, the news, however, quickly spread about the shop that something was in the air and it didn't take the men long to ferret out the fact that they were to lose their general foreman. And then the question arose—who was to be the next general foreman? From all indications Jack Donnelly would be the lucky man, for he had always acted as general foreman when Mr. Booth was sick or laying off. Donnelly was a good mechanic, a good manager of men, a good workman, steady and reliable. He was the sort of man who is a credit to any shop, and while he had been offered several good jobs at other shops, he had always refused to move. He was loyal to the heart and always would work his head off for Dan Keefe.

The "Old Man" respected his ability and thought a great deal of him, too, so naturally, when he wrote the superintendent that he was glad to have Jim Booth secure the position as master mechanic at Johnson's Landing, he took considerable pride in writing that he had a man well trained to fill the position of general foreman and gladly recommended Jack Donnelly.

That is where he spilled the beans. The superintendent came right back and told him that he had thought for some time that Wonderly needed some "new blood" and that while he would like to respect his recommendations, he was, however, sending a young man as general foreman to Wonderly who, he thought, would be a better man. Down in the corner of the letter the superintendent had noted in his own handwriting, "Use this young man well, for he is a friend of one of our officials."

How the "Old Man" did rip and snort. He was like a wild man. He was mad enough to bite a ten-penny nail in two. He cursed everybody from the call boy up. And to ease his mind, he sat down and wrote the superintendent a letter that was a classic in sarcasm. Evidently his efforts were wasted, for he received no reply. One day about two weeks later a young man arrived at Wonderly with a letter, and introduced himself as the new general foreman.

Dan Keefe had sense enough not to say what he thought. However, he was furious to think that after his years of service the company would send a young man so inexperienced to handle a big shop like Wonderly. The young man frankly admitted that he had never handled men and, furthermore, he ventured the remark that that required no special training, anyway. He said that he was a close student of system and concentration and that he felt he could rapidly build up the output at Wonderly.

What could the "Old Man" do? His hands were practically tied. He realized that if this young man was a failure, he would be blamed for the whole thing, and the chances were that he would lose his job. The young man was entirely unfitted for the position, but he had a "pull." His future was assured, no matter what happened, but Dan Keefe, with his enviable record, would be cast aside as a has been. He saw that in addition to his already burdensome duties he would now have to watch many of the little details of the general foreman's job.

It was not a very pleasant outlook, but he had given the best years of his life to the railroad, and if he laid down now all his past efforts would be wasted and his only recourse would be that of going back to work at his trade as a machinist. This thought was not altogether to his liking, for he felt that the company should at least provide for his old age by placing him in some position where they could make good use of his years of experience. He had always stuck by the railroad through success and adversity; had been laid off

when times were hard; had worked 18 hours a day when times were good and business rushing. He had suffered with the company, but had always come back smiling, ready to give them his best efforts. And now he was to be tied down with an assistant who knew practically nothing about the game, but who was assured of success by that never failing power of "a pull."

Well, the "Old Man," like all true railroad men, had to make the best of a bad bargain, so he started his new general foreman in with all the advice possible. He worked with him, watched the output, kept his eye on the supplies and did everything in his power to keep the plant going at top speed. But what a job! The new general foreman would do more damage in one day than he could straighten out in a week. For instance, it was soon noticed that many of the good workmen were absent. On investigation he found that the general foreman had the idea that discipline consisted of laying off a man for a week or ten days. The workmen quickly saw through the whole deal, and if a fellow wanted to lay off a week or ten days he would pull off some little trick so that the general foreman would lay him off. This practice got so bad that many of the best men were being laid off unjustly, and the shop output began to slow up. Maybe the "Old Man" didn't rave when he found this out. It took some strenuous efforts on his part to whip things into shape and what he told the general foreman was a plenty.

Shortly after this he noticed that many of the foremen were not as punctual as usual. The general foreman had the idea that one's organization should run just as well when the leader was absent. He made no effort himself to reach the shop on time in the morning, took a much longer time off for lunch than was allowed and would go home at night whenever he felt like it. The foremen were all quick to note these new conditions and some took advantage of them. The result was that even the workmen slowed up, and the lessening of discipline reflected in decreased output. The "Old Man" now had another hard battle on his hands and it was only by the hardest kind of work that he succeeded in breaking up the practice.

Dan Keefe was at his wits' ends. He was thoroughly disgusted. The general foreman acted and talked that big "I" and little "you" stuff so much that he actually fooled himself into believing that he was making a success of running the place. Whenever any of the higher officials visited the shop you could always find him in the foreground doing all the talking and explaining. He couldn't be told a thing. Even when actual figures were given him showing an alarming increase in costs to handle the shop he would have some sort of an explanation ready. Not being a mechanic himself, the quality of the work began to fall off. The workmen became careless. Failures and breakdowns increased amazingly, and he would pass this off by saying that the quality of present-day workmen was much inferior to the old-time mechanic—and he had a shop full of good men; men who had made many good records prior to his taking charge of the place. The workmen began to quit, and it kept the "Old Man" on the jump trying to hold them. Only by the force of his strong personality did he manage to get many of the fellows to stick.

Sick and disgusted, he was about ready to give up when one day he received a letter from a large manufacturing concern asking him to call at their main office. Bewildered at such a request, he answered the letter and said he would be there in two days.

Arriving at the office, he sent in his name and was at once taken to the office of the president of the concern.

"Mr. Keefe," said the president, "we are at a critical period in our career. Our output is not keeping pace with our demands. We have tried all sorts of schemes, but I am not satisfied with the results. We have had system men,

by which the tool is set for any desired size. The longitudinal feed is secured by a round nut on the spindle which is held between two stops in the base. By holding the nut while the spindle is revolved the chuck is fed in or out. The chuck shown is for Paxton-Mitchell packing, but it could readily be made to accommodate other forms.

THE DIFFICULTIES OF WELDING STEEL BY THE OXY-ACETYLENE PROCESS*

BY B. K. SMIITH

Welding Engineer, United States Welding Company

The question of steel welding is one of the most important of all the problems which confront the oxy-acetylene welder. A large part of this problem has to do with his preliminary knowledge of steels and his primary habits of handling the blowpipe in steel welding. The steel weld in itself is apparently one of the most easy to obtain, so that some welders are considering steel welding as a subsidiary problem of their trade because their welds look so well; yet steel welding, notably in boiler work, requires the most thought and care, and should be studied not only from the practical point of view, but also theoretically. And what are the difficulties of steel welding? They are: (1) The incorporation of iron oxide; (2) the thermal disturbance in the vicinity of the weld, and (3) the expansion and contraction problems. Therefore one needs to study: (1) The properties of various steels; (2) the phenomena produced during the melting of the metal under the oxy-acetylene torch, and (3) boiler construction.

If one has the above knowledge in a sufficient degree, the welding in itself will be then comparatively easy and successful; but if he has not, and failures occur to him, he will insist that certain operations are impractical or impossible to perform with the oxy-acetylene blowpipe. This is one of the reasons why certain companies will not trust the apparently good looking welds, and reserve to themselves the right to sanction or forbid this kind of welding for boiler or pressure work.

In studying the incorporation of iron oxide in the weld, one must know what iron oxide is and what it looks like. Iron oxide is a burnt element, created on the surface of molten steel under the action of the blowpipe and the atmospheric oxygen. It appears as white veins and foaming spots. Iron oxide will dissolve into the molten steel at the rate of a little higher than one per cent, and in this reaction it may destroy the carbon elements with the result of a decrease in the strength and elasticity of the weld.

The best remedy to reduce oxidation is to reduce the oxygen pressure as low as possible; just enough to produce a free and soft flame that will produce a continuous melting without running over the edge. This operation depends largely on one's blowpipe and the flame maintained throughout the weld. With a proper flame, one will notice the flow of the metal clean and regular, but with a too rigid flame which requires more oxygen one will notice white veins and foamy spots flowing in the molten metal. These are streaks of oxide of iron, and they will dissolve and create new ones with the progress of the weld. The molten metal is swept rather than laid in clean layers, and in some cases the metal is adhered instead of welded. Oxide of iron cannot be altogether eliminated from any kind of weld so long as we cannot protect them from the effects of the atmosphere, but it can be so decreased from the interior of the weld that its contents would do no harm to the strength of the weld.

Some good and experienced welders who have been welding for five or six years, but who have met with some failures in steel welding, will not admit that the main cause of failure is

the improper regulation of the flame because to do so would be the same as for a college student to be compelled to return to the grades to learn his A. B. C's. Most of our welders have previously mastered some other craft and have begun welding on important work without any preliminary instructions. In other words, they began at the college end without having acquired the necessary underlying primary and high school education.

What would a boilermaker think if a novice tried to put in a set of flues? Or a machinist if an apprentice attempted to make a set of dies? Yet the same boilermaker or machinist looks upon the welding blowpipe as merely a tool of his trade and thinks that all he needs to do it to go ahead and weld with it.

In studying the question of the thermal disturbance produced by the gas flame in the metal when it is raised to a fusing temperature we must not forget that it is heat which has led to the creation of many new steels, and while heat can be employed to increase the life of metals it can also reduce and destroy the life and strength of metals. Therefore, it remains for us to study carefully how we shall best make use of it.

It is a well known fact that the structure of any gas weld at the welding line, on a boiler plate, for instance, is cast metal. This metal is much lower in elongation than the boiler plate. Yet the structure of the boiler plate was originally at the mill a cast metal or something similar to the metal in the weld. But, it has been refined by the operations of heat and mechanical treatment to a strong metal that we call boiler plate. The question is this: Can we employ the heating agent with the aid of the gas blowpipe to refine the grain at the weld and its vicinity? My answer is, "Yes," provided the operator knows the physical and the chemical properties of boiler steel.

There is no more any such thing as not being able to take care of expansion and contraction in steel welding. But, in boiler welding, one will find this a problem which is difficult to solve unless he has a full knowledge of the construction of boilers.

The effects of expansion and contraction are little feared by some boiler welders because the metal to be welded possesses the property of elongation. My advice is that no welder should depend upon the metal giving, thinking that a little strain will not hurt the weld, for two reasons. The reason is that in almost all cases an intelligent welder can find a way to take care of the expansion and contraction. The second reason is that no human being can ever measure, or know how much of a strain he has left in the metal. It may be very little or it may be up to the breaking point. Such a weld may crack during its own progress or a few days after, or even six months after completion; at any rate the welder is not excusable and the failure will not only condemn the operator, but the process and the whole oxy-acetylene welding industry.

There is one point that an oxy-acetylene operator must bear in mind, and this is to make a strong weld. Economy should be considered as a secondary principle. While there must not be any useless waste in time or material, yet we must not forget that a defective weld is a waste of time and material.

POPS WASTE FUEL.—To show how fuel is being wasted, A. Sutherby, master mechanic of the Erie Railroad at the Cleveland, Ohio, shops, has placed a coal box in the most conspicuous place in the shop, containing 90 lb. of coal. The box has a glass cover lettered to show that this amount of coal is wasted when the pop valve blows for six minutes. In 30 days this shop has saved four and one-half tons of coal by using refuse wood cut up in both of the sand stores, with good results.—*Erie Railroad Magazine.*

*Abstract of a paper read before the Northwestern Welding Association, Minneapolis, Minn.

GRINDING IN LOCOMOTIVE SHOPS

The Uses to Which Internal, Cylindrical and Surface Grinding Machines May Be Put With Success

BY M. H. WILLIAMS

It is now well recognized that grinding is the most approved method of finishing various surfaces—not only on account of the superior finish but also on account of the reduced cost. The distinctive forms of grinding machines now used to a more or less extent for railway work are the internal grinder, which is suitable for finishing various bearings in valve motion parts, side rods and other motion parts; the cylindrical grinder which is used for finishing round articles such as piston rods, valve rods, crosshead pins, etc., and now used quite extensively on piston rods; and the surface grinder, which is now used for finishing locomotive crosshead guides, the flat surfaces on main and side rods, etc. Some of the uses of these machines are explained below.

INTERNAL GRINDING MACHINES

This class of machine has great possibilities for railway use. It is possible by the use of this machine in some of its forms to grind the inner surfaces or holes of practically

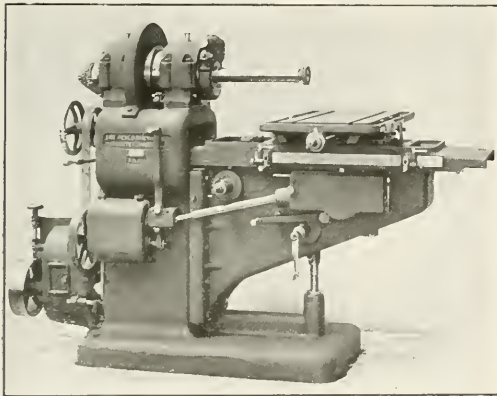

Fig. 1—A Typical Internal Grinding Machine That Has Rendered Valuable Service in Locomotive Shops

all bearings used on locomotives, the surfaces produced being much smoother and more cylindrical than those obtained by the customary turning, reaming or lapping methods. As a general practice, month in and month out, this method will be found economical, regardless of the degree of finish required, for the work can be done more quickly than by other methods and a better job will be performed, which means fewer renewals.

There are a number of forms of internal grinders and attachments on the market. One of the more common is the internal grinding attachment, used on universal or tool room grinding machines, and on which most excellent work may be done. These, however, lack the rigidity necessary for locomotive work where speed is essential.

Then there is the internal chucking grinding machines, on which the work is revolved similar to the method followed on the tool room grinders. They are rugged and will grind to the limit of the grinding wheels. This class of machine can be used for grinding the holes in bushings

used in valve motion parts, knuckle pin bushings and similar work. In some of the larger railway shops this class of machine will be found useful, its use being limited to such parts as can be revolved while being ground.

For both new and repair railway work one of the most useful machines is the internal grinder, shown in Figs. 1 and 2, on which holes may be ground without revolving the work. With this class of machine the article to be ground is secured to the machine table as shown in Fig. 2. This table resembles in many respects a milling machine table and has very similar adjustments so that the work may be brought in line with the grinding wheel spindle. The grinding spindle *A* revolves similar to the ordinary grinder spindle. The bearings for this spindle are located in a cylinder *B* that rotates slowly in the machine headstock *C*. The bearing for the spindle *A* may be adjusted to run nearly true in the cylinder *B* or can be adjusted outward to a greater extent, when desired, by turning the nut *D*. This motion is somewhat difficult to understand until the machine has been examined; afterwards it will be found to be simple. It might be likened to a portable electric grinder mounted on the face plate of a lathe, the entire grinder revolving while grinding the work which is held to the carriage of the lathe, and means being provided for moving the grinder on the face plate to and from the center to conform to the size of the hole in the work.

Fig. 2 shows the internal grinder set up to grind a part of a valve gear. It will be noted that the grinding wheel bears against the right side of the hole. As the cylinder *B* revolves one-half turn, the wheel will bear against the left side, etc., thus making a circle touching all points of the circumference of the bushing to be ground. In practice, adjustments are made to the table so that the grinding wheel will just touch the inner surface to be ground at all points. As the hole is gradually ground, the amount of eccentricity of the spindle is increased by turning the nut *D*. With this form of machine, holes from 1½ in. to 12 in. may be finished. The table for holding the work has a longitudinal motion, controlled by the customary form of tripping dogs that cause the table to travel back and forth, in a manner similar to that used on the general run of grinding machines.

There are a number of uses for this machine, as well as for the chucking grinders. The following will serve to illustrate their uses.

Holes in Valve Motion Levers and Bushings.—In repairing valve motion levers, parallel rods and various other similar parts, the holes in the rods or in the bushings or bearings applied to them are often found worn oblong or rough, or the holes in the levers are distorted as a result of the bushing becoming loose in the levers. In many cases these holes may be trued and thus avoid renewing the bushings or reaming the lever. Reaming would in some cases be the quicker operation, but it would not produce as true a hole and would result in enlarging the hole more than by grinding, thus shortening the useful life of the levers or rods. For the purpose of grinding these holes in levers, the piece may be clamped to an angle plate located on the machine table. In addition to valve motion levers, the holes in side rod knuckle pin bushings and a number of larger holes may be ground. Another use for this machine is that

of grinding the round holes in links into which the pin fits and also the holes in link blocks. These are often case-hardened and when they have become worn in service or when they have been warped in casehardening, it is much easier to true the holes by grinding than by any other method.

Air Brake Parts.—In addition to the internal grinding mentioned above, this form of machine shown may be profitably employed on various air brake parts, among which may be mentioned triple valves. The inner surfaces of the cylinders where the pistons travel should be refinished accurately and smooth. This desired surface can be obtained very quickly on the internal grinding machine and the work will be much superior to boring or reaming. For this operation the valve may be held on an angle plate secured to the machine table.

The valve chambers in the top heads of air compressors when worn, may also be refinished on this machine. For this purpose the head may be held on the machine table similar to the practice on a horizontal boring mill. The steam and air cylinders also may be refinished when worn or cut. For this operation the cylinder may be clamped to the table, similar to the method mentioned for pump heads. To refinish a very badly worn cylinder on this machine may require more time than on a boring machine on account of the large amount of metal to be removed in order to true up the entire surface. Even if this be the case, grinding will generally be the more economical when considering the life of the cylinders. When boring there is always the possibility of the workman setting the boring tools to a larger diameter than is necessary to true the cylinder in order to get below the hard surface. With grinding this danger does not exist, for the hard surface does not affect the grinding and the workman will naturally not do any more work than is necessary. Thus the bore will be enlarged just enough to remove the worn surfaces and will produce a surface equal to that given the best automobile cylinders. For this class of grinding it is the custom to grind the ridge at each end by short stroking the travel of the table until the diameter is about equal to the worn center and then allow the table to travel the full length of the cylinder.

PLAIN CYLINDRICAL GRINDERS

This form of machine may be used to good advantage in any railway shop. It would require too much space to enumerate all the uses that may be made of it. Of the more common may be mentioned the finishing of crank and knuckle pins, air pump piston rods, outer surfaces of valve motion bushings, knuckle pin bushings and piston and valve rods. Casehardened parts may be ground to a true cylindrical surface and irregularities as a result of heating when hardening may be corrected. With the present well developed grinding machines and grinding wheels, articles are finished cheaper and more superior to any other way. Therefore, this type of machine cannot be called a refinement, being valuable for new and repair work. In the latter case many a worn part may be finished that would be difficult and more expensive by other methods. Fig. 3 shows a typical grinding machine finishing piston rods.

Piston and valve rods are now largely ground in railway shops on gap grinders. This has proved a success both in the saving of time as well as in producing a superior finish. Also, when grinding, a smaller amount of metal is removed than would be necessary by the average turning. It is entirely possible by this method, to finish rods practically to one diameter for their entire length, which is an advantage in these days of superheated steam. Experience has shown that worn rods may be ground more quickly as they come to the shop without previous turning, than by first turning and then grinding. This includes

rods that have been straightened and badly cut. The principal points are the proper grade of wheel, plenty of steady rests and cooling compound. For roughing down, the lateral feed is often one inch per revolution of the work and the depth of cut from .001 in. to .003 in., which gives an indication of the speed by which metal may be removed. If not kept fully employed on piston rods and valve stem rods, these gap piston rod grinders can be used to good advantage for grinding locomotive axles and crank pins. In some cases they are too light for the larger axles. However, they can readily be made to help out the lathes. For this work the axles or pins may be rough turned to about $1/32$ in. large with the fastest feed the lathe will pull, and afterwards ground.

It is well recognized that the taper ends of crosshead, valve motion and similar pins should be carefully fitted to the taper holes in the levers or rods into which they are to be applied. These taper surfaces may be finished quickly and accurately on the plain cylindrical grinder. For this purpose the table is swiveled to the proper angle, similar to setting the taper attachment on a lathe, the table being graduated for the purpose.

The body or central portion of most of these pins is straight. Therefore, the taper is not continuous from end to end. This makes it necessary to grind one end back of the wheel and transfer the work to the opposite end. No difficulty is experienced in this operation. The customary method is to grind one end, preferably the larger, to a

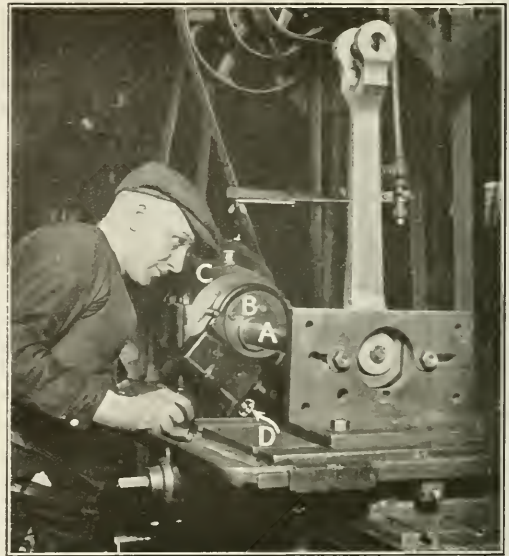

Fig. 2—Internal Grinding Machine Finishing a Bearing in a Valve Motion Link

size about .005 in. above size and set the knock-off dogs for the wheel feed or mark the micrometer dial, which may be done with the adjustable markers. The wheel is then shifted to the opposite end and the wheel fed into the previous setting. After this roughing down operation is completed, the wheel if rough or clogged with chips, should be trued with the diamond and the same operations gone through again for finishing to correct size and producing a smooth surface. Going over a pin a second time and truing the wheel may seem an extra refinement, but it will be found that the time required for this second operation will

be worth while for it will improve the finish and accuracy, which is essential with these parts. This method applies mostly to cases where only one or two pins are finished at one time.

For new work or large batches of work the pins may all be roughed down and afterwards finish ground without too frequent truing of the wheels. In some cases the pins are roughed to size and finished all in one operation, the method depending largely on the grade of grinding wheel employed. This grinding of the taper end may be done by feeding the wheel directly onto the work, in which event the wheel must be as thick as the surface is long; or the wheel may be given a lateral motion. The first method is quicker, but it is necessary to keep the wheel in perfect condition. For pins that are casehardened it is about the only method that may

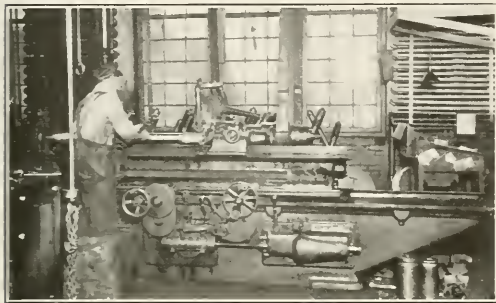

Fig. 3—Grinding a Piston Rod on a Cylindrical Grinding Machine

be followed to finish them perfectly true and to correct distortion from hardening.

The grinding of the straight surfaces of the pins is a simple operation. It is, however, very important that they fit the hole into which they are to work in a proper manner. Where the various valve motion, cross-head and similar pins are roughed out in quantities on automatic screw machines or turret lathes or in so-called central production shops the grinding machines will be found useful for the final fitting of these parts to the individual locomotives. For this method of manufacture the roughed out parts need not be closer to size or smoother than that which may be obtained by a single roughing out. Where unhardened pins are used it will be found that even if they are made considerably over size, they may be reduced to the required dimensions very quickly.

Where casehardened pins are used the grinder will prove useful. Before the pins are hardened they may be roughed out and the other work done, such as cutting keyways and drilling the necessary holes, the only requirement being to machine the straight portion close to size so that after being hardened, it will not be necessary to grind below the casehardened surface. The taper part of the pins may be left with a relatively larger amount of material to remove in finishing as grinding below the casehardened surface is not considered objectionable. This will make it possible to keep pins in stock all casehardened and where it is necessary to fit them to a locomotive, delays of waiting for parts to be casehardened will be avoided. Various sizes of semi-finished pins will be required to meet the requirements for repair work especially where the pins are casehardened in batches.

The grinding method is useful for refinishing pins that are only slightly worn, as a new surface may be obtained with a diameter minimum waste of metal. This practice is particularly valuable for repairing cross-head pins as the small reduction in the diameter of the pin will require the brasses to be closed but little. If the pin were to be turned

by the customary method a greater reduction in diameter would be necessary.

For finishing crank pins the grinder will be found useful. The more economical method of manufacture is to rough out those pins on turret or center lathes, making the journal surfaces from 1/64 to 1/32 in. large and the part fitting the wheel center large enough to meet the conditions caused by lack of uniform size in the original boring and enlargements resulting from renewing pins. The sides of the shoulders may be finished in the lathe when the pins are made or they may be made by grinding, it being necessary to remove the sharp corner of the grinding wheel to form the proper radius. This may readily be done with radius truing devices supplied by the makers of grinding machines. The part of the pin fitting the wheel center which generally varies in diameter for each pin may, also, be ground, and if it is only necessary to remove about 1/16 in. of metal, will generally be found quicker than turning. For this fitting the bore of wheel center can, to good advantage, be measured with inside micrometer calipers. Where this is done a memorandum of the size may be given to the grinder operator who can then finish the pin to the correct size for force fit. The use of micrometers for this purpose has several advantages over fitting with machinist calipers, for it is not necessary for the workman to leave his machine to go to the wheel center. In fact the information concerning the sizes can be transmitted by telephone from one shop to another. One of the greatest advantages will be that the workman will soon become accustomed to working to exact sizes which will result in allowing a uniform amount for force fit of these parts.

It is now a practice with a number of concerns to make bushings on automatic screw machines or turret lathes and afterwards grind the outside diameter to the correct size instead of endeavoring to keep to exact sizes when making them on the machine, because it was found that the time lost on the screw machines or lathes was greater than that of grinding, also the grinding resulted in superior finish and greater accuracy. The bushings used on locomotives are generally short and can be ground quickly. Where a number are to be ground at one time, it is the custom to use two arbors; while grinding on one, the second is being loaded. This practice can be used to good advantage both for steel and brass bushings. Grinding brass parts may also look like an extra refinement; its economy lays in the fact that close sizes may be obtained quicker by this method.

The internal and cylindrical grinders as mentioned above will do work now largely done on lathes in railway shops. Where additional machine tools are necessary they should be carefully considered. As far as operators are concerned a green man or woman can be broken in to operate a grinder quicker than they could be to run a lathe. The surfaces will be superior and the work can be done quicker. They however have their limitations and where a large amount of metal is to be removed they cannot compete with the lathe. But for finish and accuracy the grinders are superior.

SURFACE GRINDING

The surface grinder is now finding favor in railway shops, it being well adapted for a large amount of work. Its principal use is that of finishing cross-head guides, ends of main rods, rod keys and wedges and other flat surfaces. As now developed a number of jobs can be done on this machine quicker than on planers or shapers and produce a superior finish. Some of the machines are equipped with a magnetic chuck by which the work can be held without clamping and which saves a large amount of time when setting up a job as compared with the methods customarily followed when securing to a planer bed, this chuck being one of the very handy devices for railway work.

One of the principal uses for this machine is that of

finishing both new and repaired crosshead guides. Where the magnetic chuck is used the guide can be lined up on the chuck and the current for the magnet switched on. This is about all that is necessary for securing the work.

With new guides the tool marks from planing can be removed quickly on the surface grinder and guides worn in service may be resurfaced readily. As a general proposition a cut from .001 in. to .003 in. may be taken at each pass of the wheel. As this covers the entire surface of the guide, that may be several inches wide, the rate of cutting is fairly rapid. Worn guides may be resurfaced quicker than planing under ordinary conditions. For an extra worn guide it may be advisable to plane before grinding. The advantages of guide bar grinding are a reduction in the time required to do the work, the superior finished surface obtained and the fact that only enough metal is removed to true up the guide.

This machine is also finding favor for grinding the flat surfaces on the ends of main and side rods (Fig. 4), both for new and repair work. For new work the various blocks, straps and wedges that should be finished flush with the sides can first be planed fairly close to size and then assembled in the rod and all ground at one time. This results in all these

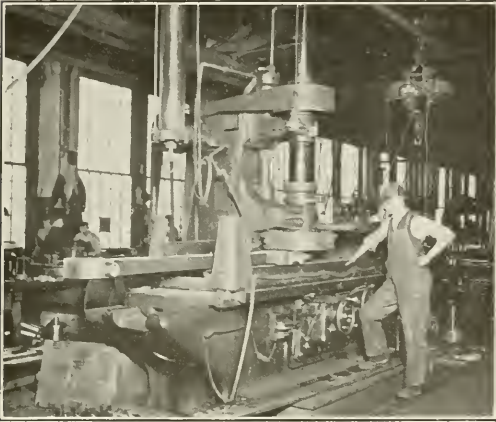

Fig. 4—Locomotive Side Rod Being Finished on a Surface Grinder

parts membering properly, also on account of the ease of measuring the ground surfaces the thickness of the rods can be made practically to drawing size, thus making the rods as far as thickness is concerned interchangeable. Worn rods may be ground on their sides to remove depressions caused by wear. This also results in the proper truing up of the rod ends which is an advantage when fitting new rod brasses. The ends of side rods are ground for the purpose of removing the roughness due to planing or milling and to insure a uniform thickness of all rods.

A number of rod keys are now ground on their flat surfaces. Where they are forged close to the required finish size as in the case of drop forging, they can be ground from the rough very quickly. When performing this operation it is the custom to cover the entire surface of the magnetic chuck with these parts. In placing these small parts on the chuck the only precaution necessary is to locate the pieces so they will rest against each other to prevent shifting and to keep the surface of the chuck clean.

Washers for crank pins and crosshead pins are also finished on the surface grinders. In this event the washers are cut from boiler or scrap sheet steel to the required diameter and the holes bored, as the sides are ground from the rough,

it is not necessary to turn the flat sides. Also thinner sheet steel may be used than would be the case if the washers were to be turned in a lathe.

Some of the surface grinders have large circular magnetic chucks. These machines may be used to good advantage for grinding the sides of piston, air pump and piston valve packing rings. The ground sides are superior to the average work done on a lathe or boring mill.

A large number of uses can be found for surface grinders and the question of their installation is well worth consideration. These machines like the grinders mentioned above may be operated by workmen having less experience than would be necessary to operate other machines for doing the same work.

GENERAL RESULTS FROM GRINDING

The advantages to be deprived from grinding may be summed up under the grade of the work performed and the accuracy.

Grade of Work.—The finish produced by grinding is universally conceded to be superior to that produced by other methods. The bearing surfaces are more accurate and any degree of smoothness can be obtained. For cylindrical pieces such as cross head pins, knuckle pins, valve motion pins, piston rods, etc., the bearing can be made of one diameter for their entire length. To produce a similar surface on a lathe requires an expert who will generally take a greater amount of time. Unquestionably this high grade of finish is desirable for locomotive work. Where casehardened parts are used the surfaces cannot be made accurate unless they be ground. Internal surfaces such as the various bearings and bushings may also be finished more accurately than by other methods, such as reaming, turning and lapping. In casehardening the parts are bound to warp and distort to a certain extent as result of the high degree of heating necessary for this operation. Where such parts are not ground the pins will naturally have a poor bearing in the companion bearing, with the possibility of it cutting or galling. Whereas where the parts are ground the surfaces will be true, making a good bearing for the entire length and also the proper amount of play may be allowed for the flow of oil, lost motion, etc. Soft pins and bushings may also be ground and obtain the same degree of accuracy. Bearings of this nature will naturally wear longer and what is more important reduce locomotive detention.

Accuracy.—A ground cylindrical surface is more easily measured than a turned surface. This is brought about from the fact that where a grinding machine is set to grind straight a measurement taken at any point will show the diameter for the entire length of the piece. In other words it is not necessary to measure at several points as is the general practice where a piece is turned and then filed and then finished with emery. For various pins, piston rods, etc., the micrometer caliper may be used very quickly. This method of measuring has the advantage as compared with solid gages or machinists' calipers that the first measurement shows the exact amount the piece is above the required size and also how much is to be removed.

BRIQUETTES OF LIGNITE IN CANADA.—The Canadian Council for Scientific and Industrial Research intends to manufacture carbonized lignite briquettes. A plant costing about £80,000 will be constructed near Estevan, Saskatchewan. The proposal is to take two tons of poor lignite with about 32 per cent of moisture and 7300 B.t.u. per lb., and turn them into one ton of briquettes containing 5 per cent moisture, and having a fuel value of 12,000 B.t.u. Sulphite liquor, the waste product from pulp mills, will be used as the binder; it is smokeless and odorless.—*Iron Age.*



CINCINNATI ACME FLAT TURRET LATHE

A new universal flat turret lathe, embodying many noteworthy features is the latest product of the Acme Machine Tool Company, Cincinnati, Ohio. This machine is well suited to handle a wide range of work, which makes it particularly well adapted for use in railroad shops. The lathe has a capacity for bar work up to $3\frac{1}{2}$ in. in diameter and 44 in. long and for checking work up to a diameter of 17 in. It is equipped with a side carriage that can be used on either bar or chucking work, thus greatly reducing the time on operations where two tools can be used simultaneously. All control levers have been centralized so that they are directly in front of the operator. Rigidity and perfect alinement between the spindle and the vees are assured by casting the head solid with the bed.

The machine is driven through a 14 in. pulley running at constant speed. The geared head gives nine speeds, rang-

stops for the longitudinal movement which are readily accessible. The square turret mounted on the cross slide is positioned by a lock bolt and can be indexed to four positions.

The cross sliding turret revolves on a stem of large diameter and is automatically locked in position by a taper plunger, working in bushings set into the solid turret. The turret is further held down at the extreme outer edge with circular clamps. The cross slide moves on a narrow dovetail guide which has a taper gib to compensate for wear. The cross speed can be operated in both directions by hand or by power. The saddle has a continuous bearing for its entire length on the vees. Power rapid traverse is provided in either direction for the turrets. Twelve longitudinal stops are provided for the turrets, one independent stop for each face and six auxiliary stops operated by an index knob at the right of the saddle. When desired, as many as seven different shoulder lengths can be machined. To pass any of the 12 longitudinal stops it is only necessary to turn the index knob half-way between any of the numbers. Power

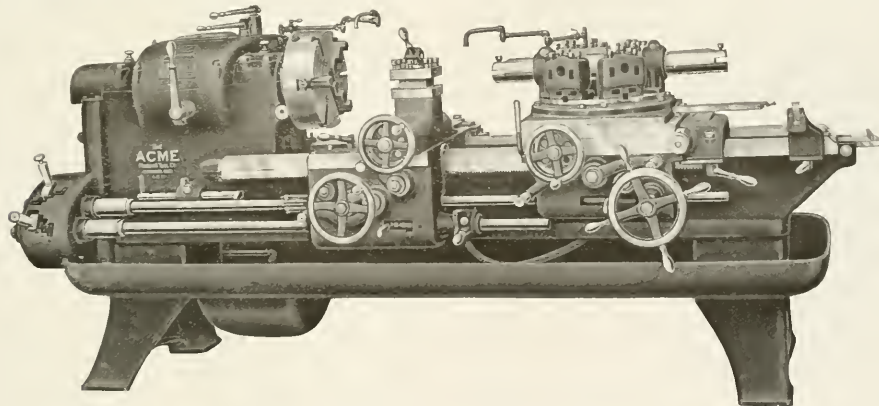

Cincinnati Acme Flat Turret Lathe

ing from 14 to 260 r. p. m. A patented gear-shifting device makes it possible to change from any speed to any other with one continuous movement of either of the two speed changing levers located on the head. When the lever has reached the point where the gears are out of mesh the driving pulley is automatically disengaged from the friction and re-engaged after the gears are again completely in mesh. The spindle is mounted in removable babbitt bearings and can be instantly started, stopped or reversed by a double cone friction operated by a lever in front of the head.

The side carriage spans the ways of the bed. It clears the chuck and can be moved out of the way to permit the use of short tools in the flat turret. It has six independent

feeds are provided for both the cross and longitudinal movements of the side carriage and the turrets. A gear box at the head of the machine furnishes ten speeds from 10 to 240 r. p. m. Positive stops are provided for the longitudinal movements, while the cross movements have large micrometer dials with observation stops. All feeds can be reversed by levers in the apron.

The bed is heavy and strongly braced by cross girths, with exceptionally large vees. A geared oil pump furnishes an ample supply of coolant with the machine running in either direction. The oiling piping is so arranged that coolant can be fed to each individual tool. A plain, tight and loose pulley countershaft is furnished with this machine, but where

conditions permit, the driving pulley may be belted direct to the line shaft. A 5 to 7½ hp. constant speed motor is recommended where individual drive is to be used.

GOLD INSIDE CONNECTED VAPOR VALVE

In the application of the vapor heating system to passenger cars the usual practice has been to place the vapor regulating valve underneath the car. To overcome the objections arising from the inaccessibility of this location and the extreme ex-

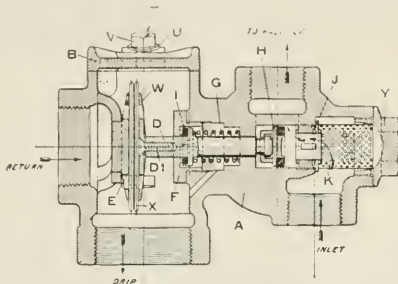

Section Through the Valve Body

posure to which the valve is subjected, the Gold Car Heating & Lighting Company has placed on the market an inside connected vapor valve which is designated as No. 1112.

The construction and operation of the valve is simple and may readily be grasped from an inspection of the sectional view. At the right are the branch pipe and radiator admission connections, the steam passing from the former to the

All working parts of the valve are readily accessible. The diaphragm chamber is closed by a flat cover *B*, held in place by two swing bolts *T*. The joint between the cover and the casing is steam tight without the use of a gasket. By removing this cover the diaphragm may quickly be removed, if necessary while the system is in operation, to accomplish which it is only necessary to turn off the steam temporarily. The admission valve disk slides into place on the end of the main stem, and may be removed by first removing the plugs in the opposite sides of the admission valve chamber.

One of the illustrations shows the position of the vapor valve with relation to the rest of the system. With the valve inside the car, in order that the temperature in the diaphragm chamber may be sensitive to outside conditions, a ventilating drip horn is used. This is divided into two parts by a vertical diaphragm, the lower end of which extends below the bottom of the horn, placed at right angles to the longitudinal center

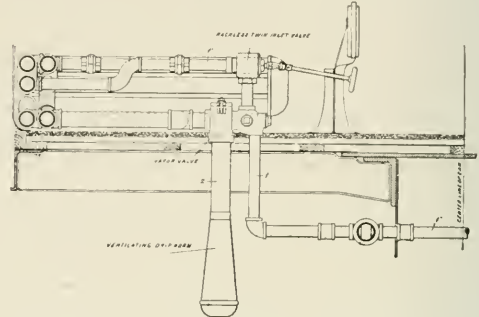

Location of the No. 1112 Vapor Valve in the Heating System

line of the car. With the car in motion, or with a wind blowing, a draft is created up one side of the ventilating horn and down the other, which ventilates the diaphragm chamber and maintains the sensitiveness of the operation of the valve. On the basis of service tests it is claimed that the valve will maintain practically a constant temperature at the return of 210 deg. F. On the other hand, with the radiators turned off, the compactness of the valve case and the directness of the operating connection between the valve and the diaphragm insures that all these parts will be sufficiently warmed by direct conduction to prevent freezing. The valve complete with the ventilating drip horn weighs only 16 lb.

SEAMLESS HOLLOW STAYBOLT IRON

The use of hollow staybolts in locomotive fireboxes has become widespread during the past few years. This is due to the fact that the federal locomotive inspection rules provide that where hollow staybolts are installed behind brick work or grate bearers, the removal of the bricks or grates each month for the purpose of hammer testing such bolts will not be required. Particular interest therefore attaches to the announcement that seamless hollow staybolts are now being manufactured from Ulster Special iron in a plant recently erected by Joseph T. Ryerson & Son, Chicago. This hollow iron is produced from the solid bar and it can be furnished to pass all railroad or other standard specifications for staybolt iron and is guaranteed not to split or develop leaks in driving.

It has been the aim in producing this hollow staybolt iron to diverge from the present practice in this country of making hollow iron from welded sections. There has been no change in the process of manufacturing the Ulster Special iron used in these bolts. This new product combines the reliability of the best solid staybolt iron with the advantages of the hollow bolt.



Gold No. 1112 Inside Connected Vapor Valve

latter through the diaphragm controlled admission valve *H*. The operation of the admission valve is controlled by an expansion diaphragm of a design which provides sufficient flexibility to obviate the necessity of the use of an adjusting screw within the range of the working pressure encountered in passenger train heating practice. The movement of the diaphragm is transmitted to the valve by a single straight stem which is normally held in position against the diaphragm by the coil spring *G*. The valve is thus always open except when closed under the action of the expansion of the diaphragm. The sensitiveness of the valve is not impaired by the use of packing on the stem.

Railway Mechanical Engineer

(Formerly the RAILWAY AGE GAZETTE, MECHANICAL EDITION
with which the AMERICAN ENGINEER was incorporated)

PUBLISHED ON THE FIRST THURSDAY OF EVERY MONTH BY THE
SIMMONS-BOARDMAN PUBLISHING COMPANY

EDWARD A. SIMMONS, *President* M. H. WIUM, *Secretary*
HENRY LEE, *Vice-President and Treasurer* L. B. SHERMAN, *Vice-President*
WOOLWORTH BUILDING, NEW YORK, N. Y.
F. H. THOMPSON, *Business Manager*, CHICAGO.

Chicago: Transportation Bldg. Cleveland: Citizens' Bldg.
Washington: Home Life Bldg.
London: Queen Anne's Chambers, Westminster.

ROY V. WRIGHT, *Editor*
R. E. THAYER, *Managing Editor*
C. B. PECK, *Associate Editor* A. F. STUEFFING, *Associate Editor*
C. W. FOSS, *Associate Editor*

Entered at the Post Office at New York, N. Y., as mail matter of the second class.

Subscriptions payable in advance and postage free; United States, Canada and Mexico, \$2.00 a year; Foreign Countries, \$3.00 a year; Single Copy, 20 cents.

WE GUARANTEE, that of this issue 6,600 copies were printed; that of these 6,600 copies 5,733 were mailed to regular paid subscribers, 57 were provided for counter and news company sales, 188 were mailed to advertisers, 64 were mailed to employees and correspondents, and 558 were provided for new subscriptions, samples, copies lost in the mail and office use; that the total copies printed this year to date were 84,350, an average of 7,668 copies a month.

THE RAILWAY MECHANICAL ENGINEER is a member of the Associated Business Papers (A. B. P.) and the Audit Bureau of Circulations (A. B. C.)

The War Department, through the department of military railways, is placing orders for approximately 40,000 freight cars for service on military railways in France, some of which may be loaned to French government railways by General Pershing.

The Federal Labor Bureau at Altoona, Pa., has calls constantly for large numbers of artisans, mechanics and laborers. The last list received from the Pennsylvania Railroad specifies 8,087 positions which need to be filled on that road. More than 200 men are wanted in the shops in that city, and 350 laborers on track work. The Cambria Steel Company is looking for 1,100 men, mostly laborers.

Make Every B. O. Locomotive a Live One

We cannot assume that there will be an early cessation of fighting. We are not going to stop fighting until we get this thing finished. Pershing needs locomotives—why? Because we have the Germans on the move to Berlin and they are moving so fast that it takes American locomotives to keep up with them. Pershing wants locomotives that we need for the railroads of the United States, and he wants steel rails over there to put those locomotives on so he can keep up with the Germans. I have said that General Pershing can have those locomotives, as we railroad men will see that he gets anything he needs from the railroads of the United States. We can give him those locomotives only if you make every bad order locomotive a live one as quickly as you possibly can do it. I want you to work all the harder on these dead locomotives. A bad order locomotive is a Prussian soldier, and I want you to jump on every Prussian soldier that gets into the shops, mark "Prussian" on him in chalk

and then hammer hell out of him until you convert him into a live American soldier. This is the way you can help Pershing and the boys in France. (From an address by Director General W. G. McAdoo at Connellsville (Pa.) shops on October 13.)

Revision of M. C. B. Interchange Rules for 1918-19

All prices shown in rules 98, 101, 107, 111 and 112 of the M. C. B. rules became effective October 1, 1918, according to Supplement A to Circular No. 16, referring to the revised interchange rules. Revised rules 104, 106 and 108 also became effective October 1, 1918. However, it should be understood that old rules 58 and 95 governing responsibility are still effective. That portion of rule 104 which allows material charge for missing brake beams, and that portion of rule 111 which allows charge for missing airbrake parts is effective November 1, 1918.

Circular No. 45, which provides that no bill shall be made for certain items of minor repairs to railroad-owned cars, has been modified to apply only to cars belonging to roads under United States federal control; this provision also became effective October 1, 1918, and is known as Article III.

More Cars and Locomotives Ordered

It is reported that the United States Railroad Administration has ordered 600 locomotives in addition to the 1,415 which have already been ordered. It is expected that 500 of these will be built by the American Locomotive Company and 100 by Lima, the orders being distributed as follows: American Locomotive Company 150 eight-wheel switchers, 50 six-wheel switchers, 150 light Mikados, 50 heavy Mikados,

RAILROAD CLUB MEETINGS

Club	Next Meeting	Title of Paper	Author	Secretary	Address
Canadian	Nov. 12, 1918	Co-ordination of the Various Branches of the Mechanical Department	W. U. Appleton	James Powell	P. O. Box 7, St. Lambert, Que.
Central	Nov. 14, 1918	Discussion: How Can a Railroad Man Help Win the War? Annual dinner			
Cincinnati		Looking Forward	Harry D. Vought	H. Boutet	95 Liberty St., New York
New England	Nov. 12, 1918				101 Carew Bldg., Cincinnati, Ohio
New York	Nov. 15, 1918	Purpose and Work of the Fuel Conservation Section	Eugene McAniff	W. E. Cade, Jr.	683 Atlantic Ave., Boston, Mass.
Pittsburgh					95 Liberty St., New York
St. Louis	Nov. 8, 1918	Organization of the Students' Army Training Corps	Prof. A. S. Langsdorf	M. J. Hepburn	102 Penn Station, Pittsburgh, Pa.
Western	Nov. 18, 1918	Work and Organization of the Fuel Conservation Section	Major E. C. Schmidt	A. F. Stueffing	750 Transportation Bldg., Chicago

25 light Santa Fe locomotives and 75 Mallets of the 2-8-8-2 type. The Lima Locomotive Corporation is to have 100 light Mikados.

It is also reported that 2,000 coal cars will be built to the designs of the Norfolk & Western's 100-ton type cars with six-wheel trucks, with the exception of certain standards adopted on the other standard freight cars. These will be built for the Virginian in order to enable that road to use cars of high capacity to accommodate the requirements of that road. But few of these cars will get off the line of the Virginian.

MEETINGS AND CONVENTIONS

New York Railroad Club.—At the recent monthly meeting of the New York Railroad Club, D. W. Pye, president of the Tuco Products Company, Inc., was elected treasurer to succeed the late R. M. Dixon. Roy V. Wright, editor of the *Railway Mechanical Engineer*, has been appointed chairman of the subjects committee.

Manufacturers of Chilled Car Wheels.—The Association of Manufacturers of Chilled Car Wheels held its annual meeting October 15 at the Waldorf-Astoria, New York. The following officers were elected for the coming year:

President and treasurer, George W. Lyndon; vice-presidents, E. F. Carry, president, Haskell & Barker Car Company, and J. A. Kilpatrick, president, Albany Car Wheel Company; secretary, George F. Griffin, president, Griffin Wheel Company; consulting engineer, F. K. Vial, chief engineer, Griffin Wheel Company.

Railway Equipment Manufacturers' Association.—At the annual meeting of the Railway Equipment Manufacturers' Association, which was held during the Traveling Engineers' Convention, \$100 was contributed to the Railway Regiments' Tobacco Fund and \$200 to the American Red Cross. The following officers were elected for the ensuing year: President, Gilbert E. Ryder, Locomotive Superheater Company; vice-president, C. W. Floyd Coffin, Franklin Railway Supply Company; secretary, D. L. Eubank, Galena Signal Oil Company; treasurer, B. C. Hooper, American Steel Foundries; executive committee members for three years, C. L. Brown, Manning, Maxwell & Moore; Morris Brewster, United States Metallic Packing Company, and F. W. Venton, Crane Company.

The following list gives names of secretaries, dates of next or regular meetings and places of meeting of mechanical associations:

AIR BRAKE ASSOCIATION.—F. M. Nellis, Room 3014, 165 Broadway, New York City.
AMERICAN RAILROAD MASTER TINNERS', COPPERSMITHS' AND PIPEFITTERS' ASSOCIATION.—O. E. Schlink, 485 W. Fifth St., Peru, Ind.
AMERICAN RAILWAY MASTER MECHANICS' ASSOCIATION.—V. R. Hawthorne, 746 Transportation Bldg., Chicago.
AMERICAN RAILWAY TOOL FOREMEN'S ASSOCIATION.—R. D. Fletcher, Belt Railway, Chicago.
AMERICAN SOCIETY FOR TESTING MATERIALS.—C. L. Warwick, University of Pennsylvania, Philadelphia, Pa.
AMERICAN SOCIETY OF MECHANICAL ENGINEERS.—Calvin W. Rice, 29 W. Thirty-ninth St., New York.
ASSOCIATION OF RAILWAY ELECTRICAL ENGINEERS.—Joseph A. Andreucetti, C. & N. W., Room 411, C. & N. W. Station, Chicago.
CAR FOREMEN'S ASSOCIATION OF CHICAGO.—Aaron Kline, 841 Lawlor Ave., Chicago. Meetings second Monday in month, except June, July and August, Hotel Morrison, Chicago.
CHIEF INTERCHANGE CAR INSPECTORS' AND CAR FOREMEN'S ASSOCIATION.—W. R. McMurphy, New York Central, Albany, N. Y.
INTERNATIONAL RAILROAD MASTER BLACKSMITHS' ASSOCIATION.—A. L. Woodworth, C. H. & D., Lima, Ohio.
INTERNATIONAL RAILWAY FUEL ASSOCIATION.—J. G. Crawford, 542 W. Jackson Blvd., Chicago.
INTERNATIONAL RAILWAY GENERAL FOREMEN'S ASSOCIATION.—William Hall, 1061 W. Wabasha Ave., Winona, Minn.
MASTER BOILERMAKERS' ASSOCIATION.—Harry D. Vought, 95 Liberty St., New York.
MASTER CAR BUILDERS' ASSOCIATION.—V. R. Hawthorne, 746 Transportation Bldg., Chicago.
MASTER CAR AND LOCOMOTIVE PAINTERS' ASSOCIATION OF U. S. AND CANADA.—A. P. Dene, B. & M., Readier, Mass.
NEARBY FRONTIER CAR MEN'S ASSOCIATION.—George A. J. Hochgrebe, 623 Brisbane Bldg., Buffalo, N. Y. Meetings, third Wednesday in month, Stabler Hotel, Buffalo, N. Y.
RAILWAY STOREKEEPERS' ASSOCIATION.—J. P. Murphy, Box C, Collinwood, Ohio.
TRAVELING ENGINEERS' ASSOCIATION.—W. O. Thompson, N. Y. C. R. R., Cleveland, Ohio.

PERSONAL MENTION

FEDERAL ADMINISTRATION APPOINTMENTS

WILLIAM W. MORRIS, formerly of the purchasing department of the Pennsylvania, at Philadelphia, has been appointed secretary of the Central Advisory Purchasing Committee, with office at Washington, D. C.

THOMAS E. PARADISE, whose appointment as mechanical assistant on the staff of the Central Western regional director, with headquarters at Chicago, was announced in the October *Railway Mechanical Engineer*, was born at Peoria, Ill., on November 22, 1880. Mr. Paradise entered railway service on October 2, 1897, as a machinist apprentice with the Chicago, Burlington & Quincy at Hannibal, Mo. Five years later he enlisted in the United States navy as a second-class machinist, in which capacity he served four years. At the expiration of his enlistment he returned to Hannibal and entered the service of the Chicago, Burlington & Quincy as a machinist. In 1912, he was promoted to roundhouse foreman at LaCrosse, Wis., and in 1916, he became master mechanic at Centerville, Iowa. The following year he was transferred to Hannibal in the same capacity, where he remained until his appointment as mentioned above.

F. S. WILCOXEN, special representative of the Perolin Railway Service Company at Chicago, has been appointed assistant fuel supervisor of the Northwestern region of the Railroad Administration, with headquarters at Portland, Ore. Mr. Wilcoxen's biography and picture were published in the *Railway Mechanical Engineer* for January, 1918, on page 71.

GENERAL

W. J. BOHAN, mechanical engineer of the Northern Pacific, has been appointed assistant mechanical superintendent, with headquarters at St. Paul, Minn.

B. J. FARR, master mechanic of the Grand Trunk (Western Lines), at Battle Creek, Mich., has been appointed superintendent of motive power and car department of the Western Lines, with headquarters at Detroit, Mich., succeeding W. H. Sample, who has gone to the Grand Trunk in Canada.

T. A. FOQUE, general mechanical superintendent of the Minneapolis, St. Paul & Sault Ste. Marie, has had his jurisdiction extended to include the Duluth, South Shore & Atlantic and the Mineral Range, with headquarters at Minneapolis, Minn.

J. F. GRAHAM, superintendent of motive power of the Oregon-Washington Railroad & Navigation Company, with office at Portland, Ore., has had his jurisdiction extended over the Southern Pacific north of Ashland, and the Pacific Coast Railroad.

H. F. GREENWOOD, superintendent of shops of the Norfolk & Western, with office at Roanoke, Va., has had his jurisdiction extended to include all departments at East Roanoke shops.

G. O. HAMMOND, general mechanical superintendent of the New York, New Haven & Hartford, with offices at New Haven, Conn., has resigned, effective November 1.

R. E. JONES has been appointed fuel and oil supervisor of the Duluth & Iron Range and the Duluth, Missabe & Northern.

A. KEARNEY, assistant superintendent motive power of the Norfolk & Western at Roanoke, Va., has been appointed superintendent motive power, with office at Roanoke, succeeding W. H. Lewis, retired.

E. R. MANOR, chief electrician of the Northern Pacific, at St. Paul, Minn., is now assistant engineer of tests.

A. J. MERRIWETHER, road foreman of engines of the Mobile & Ohio and the Southern Railroad in Mississippi, has been appointed fuel supervisor, with office at Jackson, Tenn.

W. L. ROBINSON has been appointed supervisor of fuel consumption on the Baltimore & Ohio Western Lines, the Dayton & Union Railroad, and the Dayton Union Railroad, with headquarters at Cincinnati, Ohio.

SILAS ZWIGHT, general master mechanic of the Northern Pacific, has been appointed assistant mechanical superintendent, with headquarters at St. Paul, Minn.

MASTER MECHANICS AND ROAD FOREMEN OF ENGINES

J. J. BARRY, master mechanic of the Norfolk & Western at Portsmouth, Ohio, has been appointed general master mechanic, with office at Roanoke, Va. He will have jurisdiction over all shops and motive power department employees other than at East Roanoke shops.

G. W. CUNDIFF has been appointed road foreman of engines of the Mobile & Ohio and the Southern Railroad in Mississippi, with headquarters at Jackson, Tenn., succeeding A. J. Merriwether, transferred to other duties.

C. GRIBBON has been appointed division master mechanic of the Canadian Pacific, London division, with office at London, Ont., in place of A. Maynes, transferred.

HARRY MODAFF has been appointed division master mechanic of the Chicago, Burlington & Quincy, at Hannibal, Mo., succeeding Thomas E. Paradise, promoted.

W. WALTON has been appointed division master mechanic of the Canadian Pacific Eastern Lines, at Farnham, Que., succeeding W. Wells, transferred.

JAMES D. YOUNG has been appointed road foreman of engines on the Lehigh & Susquehanna division of the Central of New Jersey, with office at Ashley, Pa.

CAR DEPARTMENT

J. BROOKS has been appointed assistant master car builder of the Grand Trunk, at the London, Ont., shops.

I. N. CLARK has been appointed master car builder on the Ontario lines of the Grand Trunk, with headquarters at London, Ont., succeeding T. A. Treleven, retired.

W. F. PAULUS has been made steel car foreman of the Erie at Kent, Ohio, succeeding I. M. Lower, transferred.

W. A. PITT has been appointed assistant master car builder at the Montreal, Que., shops of the Grand Trunk.

SHOP AND ENGINEHOUSE

W. A. BLACK has been appointed locomotive foreman of the Canadian Pacific at Farnham, Que., succeeding D. W. Watson, transferred.

PURCHASING AND STOREKEEPING

J. H. CLEMMITT has been appointed purchasing agent of the Norfolk & Western, with office at Roanoke, Va., succeeding E. T. Burnett. Mr. Clemmitt was born November 20, 1881, in Richmond, Va. He was educated in the public schools and entered the service of the Norfolk & Western in November, 1896, filling various positions in the office of the purchasing agent. His entire railroad and business experience has been with the Norfolk & Western. On December 1, 1913, he was appointed chief clerk, which position he held until his recent appointment as purchasing agent.

W. L. ECTOR, division storekeeper of the Central of Georgia, with office at Cedartown, Ga., has been appointed division storekeeper at Columbus, succeeding R. L. Geeslin.

C. S. FILLER has been appointed storkeeper of the Baltimore & Ohio Railroad, Eastern Lines, with office at Keyser, W. Va., succeeding E. A. Workman, transferred.

T. C. HOPKINS, assistant storekeeper of the Baltimore & Ohio, Eastern Lines, at Glenwood, Pa., has been appointed storekeeper with the same headquarters, succeeding T. H. Barker, assigned to other duties.

W. A. LINN, purchasing agent of the Chicago, Milwaukee & St. Paul, with headquarters at Chicago, has had his jurisdiction extended over the Escanaba & Lake Superior and the Ontonagon Railroad, with the same headquarters.

E. T. STONE, purchasing agent of the Minneapolis, St. Paul & Sault Ste. Marie, with office at Minneapolis, Minn., has had the Lake Superior Terminal & Transfer Railroad included in his jurisdiction.

G. P. WARD has been appointed division storekeeper of the Central of Georgia at Cedartown, Ga., succeeding W. L. Ector.

O. H. WOOD, assistant purchasing agent of the Great Northern, at Seattle, Wash., has been appointed purchasing agent of the Pacific Coast Railroad, with the same headquarters, succeeding G. W. Saul.

OBITUARY

ROBERT A. BILLINGHAM, for the last two years mechanical superintendent of the Tennessee Central with office at Nashville, Tenn., died on September 29 at Schenectady, N. Y.

HIRAM W. BELNAP, manager of the safety section of the division of operation, United States Railroad Administration, and formerly for seven years chief of the Bureau of Safety



H. W. Belnap

of the Interstate Commerce Commission, died at his home in Washington on October 12, of pneumonia, following an attack of the Spanish influenza. Mr. Belnap was 51 years of age and had been connected with the Interstate Commerce Commission for 15 years. For eight years he was an inspector of safety appliances for the commission and in 1911 he was made chief inspector of safety appliances, his title having been changed later to

chief of the Bureau of Safety. Previous to his connection with the commission he had 34 years of experience in various capacities in practical railroad service in train operation. He was appointed manager of the safety section under the Railroad Administration last February and for a time continued to exercise his usual functions with the Interstate Commerce Commission, but on July 1 he resigned his office with the commission to devote his entire time to the new work, in which he has been engaged in supervising and organizing the safety departments of the railroads in accordance with a uniform plan designed to provide centralized supervision, not only to insure proper practices, but in order that each railroad might promptly secure the advantage of experience which other roads have had in safety work.

ROY B. SMITH, assistant electrical engineer, Pennsylvania Lines West, at Columbus, Ohio, died on October 19.

SUPPLY TRADE NOTES

Oscar F. Ostby, railway supplies, has moved his office from 2736 Grand Central Terminal, New York, to Room 1044 in the same building.

M. M. Auerbach, assistant secretary and assistant treasurer of the National Railway Devices Company of Chicago, died at his home in that city on October 9.

S. W. Baker has been appointed manager of the extra work department of the Lima Locomotive Works, Inc., and M. K. Tate has been appointed manager of the service department.

C. D. Norton, sales engineer for the Page Steel & Wire Company, New York, has resigned that position to become a captain in the General Engineer Depot, U. S. A., at Washington.

H. G. Elfborg, consulting engineer and director of the Ajax Forge Company, has severed his connection with that concern. Mr. Elfborg was connected with that company for the past 23 years.

The Pacific Car & Foundry Company is having plans prepared for a one-story plate shop, 100 ft. by 340 ft., to be constructed on East Fifty-fifth street, Portland, Ore. The building will cost about \$50,000.

Garland P. Robinson, who has been assistant chief inspector of locomotive boilers for the Interstate Commerce Commission since March, 1911, resigned that office to take a place with the American Locomotive Company.

Frank W. Furry, president of the Ohio Injector Company, died at his home in Chicago on October 23, after a short illness, at the age of 60 years. Mr. Furry was born at Wadsworth, Ohio, on February 25, 1858. From 1884 to 1893 he was connected with the Ferdinand Shumacher Milling Company, now the Quaker Oats Company, and was then until April, 1894, in railway service, having been employed on the Atlantic & Great Western as a telegraph operator at Sherman, Ohio, and on the New York, Pennsylvania & Ohio as telegraph operator at Akron, Ohio, and later as city agent of the Valley Railway. Mr. Furry moved to Chicago in April, 1894, when he organized the Ohio Injector Company of Illinois, with which company he had since been actively engaged and was its president at the time of his death.



F. W. Furry

M. F. Covert, assistant master car builder of Swift & Co., Chicago, has been appointed sales manager of the Chicago and northwest territory of the Standard Car Construction Company, with office in the Peoples Gas building, at Chicago.

F. O. Bunnell, chief engineer of the Southern Wheel Company, St. Louis, Mo., and formerly engineer of tests on the Chicago, Rock Island & Pacific, has been elected vice-presi-

dent of the Southern Wheel Company, with headquarters at St. Louis.

The Locomotive Pulverized Fuel Company, New York, has received an order from Morris & Company, packers, for the installation of complete apparatus for pulverizing, distributing and burning powdered coal in the company's plant at Oklahoma City, Okla.

J. M. Hopkins, chairman of the board of the Camel Company, Chicago, has been appointed a member of the priorities committee of the War Industries Board. Mr. Hopkins will handle export matters except those for Japan and for the allied governments having war missions.

M. V. Bailliere, formerly mechanical engineer of the New York Central lines west of Buffalo, with headquarters at Cleveland, Ohio, has become associated with the Roberts & Schaefer Company, at Chicago, as contracting engineer, succeeding Clyde C. Ross, who has been promoted to contracting manager. In his new position, Mr. Bailliere will be engaged in the designing, contracting and erection of locomotive coal-plant, "R and S" gravity sand plants and cinder handling plants. He is a graduate of the mechanical engineering school of Cornell University. After completing his work at Cornell he went to the Helena Power Transmission Company at Butte, Mont., where he remained for approximately a year and a half, following which he entered the service of the New York Central as a draftsman in the engineering department at Cleveland, Ohio. Subsequently he became assistant engineer and mechanical engineer, resigning from the latter position to go to the Roberts & Schaefer Company, as mentioned above.



M. V. Bailliere

The T. H. Symington Company, Rochester, N. Y., has closed its Chicago and Baltimore offices for the period of the war. All inquiries and correspondence from the Chicago territory will be handled by the Rochester office and from the Baltimore territory by the New York office.

Lloyd H. Atkinson has resigned as vice-president of the Air Reduction Sales Company, Inc., 120 Broadway, New York. Mr. Atkinson has been in poor health for some time, as a result of overwork, and will take an extended vacation before engaging in one of the war service activities.

A. M. Brown, assistant manager of the compressor sales division of the Chicago Pneumatic Tool Company at New York, has been appointed district manager of sales, with office at Philadelphia, Pa., succeeding G. A. Barden, who will remain in Philadelphia as sales representative for the company.

Paul G. Cheatham, sales representative of the Baldwin Locomotive Works and the Standard Steel Works at St. Louis, Mo., has been transferred to the Chicago office, succeeding A. S. Goble, now southwestern district representative, with headquarters at St. Louis, Mo. Mr. Cheatham's transfer was effective October 1.

The Chicago Railway Supplies Liberty Loan Committee, of which Charles K. Knickerbocker, vice-president

of the Griffin Wheel Company, was chairman, secured subscriptions from railway supply companies amounting to \$6,875,000, which was greatly in excess of the quota of \$5,270,000 assigned to the committee.

Frank H. Brown has been appointed sales manager of the Sherritt & Stoer Company, Inc., Philadelphia, Pa., and assumed his new duties October 7. Mr. Brown was one of the founders of the Brown & Zortman Machinery Company, Pittsburgh, Pa., and has been associated more recently with the Davis Machine Tool Company of Rochester, N. Y.

H. E. Chilcoat, who was recently made manager of the Clark Car Company, manufacturers of the Clark extension side dump car, was born in Orbisonia, Pa., and received his



H. E. Chilcoat

early education in the public schools at that place. In 1900 he went to the Pittsburgh district, entering the employ of the Pennsylvania Railroad as machinist helper and served successively as work inspector, gang foreman and foreman of the air brake department until 1906, when he left the railroad company to enter the service of the Westinghouse Air Brake Company as traveling inspector. Shortly after joining the Westinghouse organization he was assigned to

the Southeastern district with headquarters at Richmond, Va. In 1910, he was transferred to the Pittsburgh district office as representative, looking after the commercial interests of the company in the district served by that office until August, when he resigned to take up the duties of his present position, with headquarters at Pittsburgh, Pa.

Lauren J. Drake, president of the Standard Oil Company of Indiana, died at his home in Chicago on October 10. Mr. Drake was born at Buffalo, N. Y., on January 29, 1846. For years he was a director of the Standard Oil Company of New Jersey, vice-president and director of the Galena Signal Oil Company and active in other Standard oil properties.

John R. Edmonds, traveling representative of the Schroeder Headlight & Generator Company, Evansville, Ind., has entered the Engineers (Ry.), U. S. Army, at Ft. Benjamin Harrison, Indianapolis, Ind. Mr. Edmonds is attached to an operating railway regiment which is being organized to assist in the operation of the U. S. Military Railways in France.

A. G. Lapierre, until recently assistant in the Northwestern regional director's office, has been appointed traffic manager of the Chicago Pneumatic Tool Company, with headquarters at Chicago, succeeding E. H. Greene, resigned. F. O. Southbrook, efficiency man with Joseph T. Ryerson & Sons, Chicago, has been appointed manager of the order and production department of the same company, with headquarters at Chicago.

At a meeting of directors of the Safety Car Heating & Lighting Company, the vacancy caused by the death of Robert M. Dixon, president of the company, was not filled, but W. L. Conwell, vice-president, was appointed executive officer of the company with full powers of the president. At a meeting of directors of the Pintsch Compressing Company, J. A. Dixon, vice-president, was appointed executive officer with full powers of the president.

Charles E. Goodnow, formerly assistant sales manager of the electrical and special wire department of the American Steel & Wire Company, and more recently identified with building construction work in Washington and Brooklyn for the army and navy, is now with the Page-Steel & Wire Company, 30 Church street, New York. Mr. Goodnow's efforts will be devoted to sales and service work for Armco iron welding rods and "Copperclad" electrical wire.

The Walter A. Zelnicker Supply Company, St. Louis, Mo., announces the appointment of R. H. Wilson as assistant to the president, with office at St. Louis. Mr. Wilson, who has been with the company for years, latterly as Houston, Texas, representative, is succeeded there by E. O. Griffin, formerly storekeeper and assistant general manager of the International & Great Northern and more recently assistant to the president of the St. Louis Southwestern in charge of purchases.

W. W. Coleman, president of the Bucyrus Company, South Milwaukee, Wis., and T. H. Symington, president of the T. H. Symington Company, Rochester, N. Y., have both been appointed special representatives to the chief of ordnance, with office at Washington. Mr. Coleman will be in charge of all matters relative to the production of cannon, carriages and their equipment, appurtenances and accessories. Mr. Symington will have charge of artillery ammunition, metal components.

The Chicago Pneumatic Tool Company is contemplating the construction of a reinforced concrete plant in Detroit, Mich., which will be five stories in height, with a finished basement, and will cost between \$200,000 and \$250,000. The structure will be 180 ft. by 60 ft. The company also will build a 45 ft. by 150 ft. extension to the erecting department at its No. 2 plant at Franklin, Pa. The building will be of brick and steel construction, and will cost about \$30,000. Bids are now being received on these buildings.

Lieut.-Col. Robert Patterson Lamont, president of the American Steel Foundries, who has been assistant chief in the procurement division of the ordnance department of the



Lieut.-Col. R. P. Lamont

army, has been promoted to succeed Brig.-Gen. Samuel McRoberts as division chief of ordnance, with headquarters at Washington, D. C. His military rank, however, continues the same. Col. Lamont was born at Detroit, Mich., on December 1, 1867, and graduated from the University of Michigan in 1891. After leaving college he was engaged as engineer of construction at the World's Columbian Exposition in Chicago, and from 1892 to 1897, was secretary and engineer of the contracting firm, Shailer & Schinglau. He then became connected with the Simplex Railway Appliance Company as first vice-president. In 1905, he was elected first vice-president of the American Steel Foundries, and was elected president in 1911.

Phillips Wesley has been appointed manager in charge of the oxyhydrogen plant and sales office of the International Oxygen Company at Pittsburgh, Pa. The company announces also that Jack Heller, long with L. Heller & Sons, has joined its New York sales force, succeeding Mr. Barnitz.

George Quelch, one of the staff engineers of the International Oxygen Company, 115 Broadway, New York, sailed recently for England to supervise the installation of a 480-cell plant of unit oxyhydrogen generators for the British admiralty.

John P. Hopkins, chairman of the board of directors of the Independent Pneumatic Tool Company, and former mayor of Chicago, died in that city on Sunday, October 13. He was ill only a few days and death was attributed to a weak heart superinduced by an attack of Spanish influenza. Mr. Hopkins was born in Buffalo, New York, in 1858. He moved to Chicago in 1880 and accepted a position with the Pullman Palace Car Company as a machinist. Later he went into business for himself as a partner in the firm of Secord & Hopkins, general merchandise, at Pullman, Ill. This venture proved successful and was the foundation for a large fortune. Mr. Hopkins was a national figure in politics. He served the unexpired term of Carter H. Harrison, Sr., as mayor of Chicago in 1893-94, and was several times chairman of the Democratic National Committee. Since the beginning of the war he has served as secretary of the Illinois Council of Defense. In 1905 he became interested in the Independent Pneumatic Tool Company and was the largest stockholder. He was one of the original organizers of this company and was chairman of the board of directors at the time of his death.

Robert M. Dixon, president of the Safety Car Heating & Lighting Company, and of the Pintsch Compressing Company, New York, died at his home in East Orange, N. J., October 16, of heart disease. Mr. Dixon had been associated with the Safety Car Heating & Lighting Company or one of its predecessors since 1883. He was born September 19, 1860, at East Orange, N. J., in the house where he lived at the time of his death. He was educated in the public schools and graduated from Stevens Institute of Technology in the class of 1881 with the degree of mechanical engineer. For two years he was employed with the Delaware Bridge Company, of Trenton, N. J., leaving that company in March, 1883, to become assistant engineer of the Pintsch Lighting Company, which was merged with the Safety Car Heating & Lighting Company in 1887, with Mr. Dixon as chief engineer. He was elected vice-president of the company on January 15, 1902, and became its president in May, 1907, which office he held at the time of his death. Mr. Dixon spent the greater part of his life in the field of railway car heating and lighting, being identified with the first application of steam from the locomotive for heating railway passenger cars and with the development of gas and electricity for lighting railway cars. He was also active in the field of harbor and coast lighting. Mr. Dixon was a member of the American Society of Mechanical Engineers for 35 years. He was a trustee and a member of the finance committee of the United Engineering Societies from 1917 until the time of his death. He was also active as an executive officer of the New York Railroad Club from its early days. He served as treasurer since 1903, prior to which he was chairman of the financial committee. He was a member of the executive committee of the club for 35 years.



R. M. Dixon

CATALOGUES

PULVERIZED FUEL.—The Locomotive Pulverized Fuel Company, New York, in bulletin No. 6 describes results obtained from burning coal under stationary boilers with the "Lopulco" pulverized fuel system.

PNEUMATIC AND ELECTRIC TOOLS.—The Independent Pneumatic Tool Company, Chicago, has recently issued circular No. 27 illustrating and describing in convenient tabular form the line of Thor pneumatic and electric tools which the company manufactures. These include the Thor cylinder and turbine air drills, electric drills, pneumatic hammers, pneumatic holder-ons and pneumatic sand rammers.

WELDING AND CUTTING APPARATUS.—The Bastian-Blessing Company, Chicago, has issued a 26-page catalogue illustrating complete units of Rego welding and cutting apparatus, and giving complete descriptions of the cutting and welding torch details and the Rego diaphragm regulator details. The company's line of oxygen, acetylene and hydrogen welding regulators and adapters is also illustrated.

BATTERY CHARGING EQUIPMENT.—The Cutler-Hammer Manufacturing Company, Milwaukee, Wis., has recently issued a four-page, illustrated pamphlet describing the C-H sectional battery charging equipment for electric vehicles and industrial trucks. Some of the distinctive points claimed for this kind of equipment are the adoption of a standard unit as the basis for forming panels and groups of panels, and the ability to make future equipment conform and be an addition to present equipment.

THREADING MACHINERY.—An attractive 78-page catalogue, No. 24, has been issued by the Landis Machine Company, Waynesboro, Pa., which is devoted almost entirely to a detailed description of Landis bolt threading and screw cutting machinery, but also briefly describes the Landis pipe and nipple threading machine and the Landis pipe threading and cutting machine. It contains many illustrations of the machines and sketches of the detail parts, as well as a table of U. S. standard, V, Whitworth and International threads and a table showing cutting speeds per revolution of head per minute.

HORIZONTAL BORING MACHINE.—A detailed description of the Landis No. 35 floor type horizontal boring, milling and drilling machine, illustrated with numerous photographs of the assembled machine and its parts, is contained in a 15-page catalogue issued by the Landis Machine Company, Waynesboro, Pa. This machine has an almost universal range of adaptability and may be used to bore, mill, drill, tap, spline, oilgroove, or rotary-plane at one setting and when a swiveling table is used, the work can be finished on all sides without resetting. The catalogue also contains a sketch showing a sectional view of the spindle driving and feeding mechanism, with all of the details numbered.

PIPE CORROSION.—A paper entitled The Preservation of Hot Water Supply Pipe in Theory and Practice, presented by F. N. Speller and R. G. Knowlands at the annual meeting of the American Society of Heating and Ventilating Engineers and published in the journal of that society, has been reprinted in a 24-page booklet by the National Tube Company, Pittsburgh, Pa. This is a treatise on the subject of pipe corrosion and of the factors controlling it, and the broad, simple principles applying to every case of corrosion are briefly discussed with particular reference to hot water supply systems. The discussion of the paper at the meeting is included, and the text is illustrated with several sketches and photographs.

Railway Mechanical Engineer

Volume 92

December, 1918

No. 12

CONTENTS

EDITORIALS:

The Red Cross Christmas Roll Call.....	641
Improve Air Brake Maintenance.....	641
Why Retain Long Pilots on Locomotives?.....	642
Uniform Engine Failure Reports.....	642
Full Day's Work for Full Day's Pay.....	642
Don't Overlook the Foremen.....	642
Director-General McAdoo Resigns.....	643
New Books.....	643

COMMUNICATIONS:

Working Conditions of Mechanical Department Foremen.....	644
The "Doughboy" and the Men Who Get the "Dough".....	644

GENERAL:

Locomotive Feed Water Heating.....	645
A. T. & S. F. 4-8-2 Type Locomotives.....	649
Superheater Locomotive Performance.....	652
Railroad Administration News.....	655
Radiant Heat and Firebox Design.....	658

CAR DEPARTMENT:

Adapting Baker Heaters to Burn Soft Coal.....	661
Piston Travel and Braking Power.....	662
Standard U. S. K. A. Refrigerator Car.....	663

Passenger Car Cleaning.....	668
M. C. B. Circular on Air Brake Maintenance.....	669

SHOP PRACTICE:

Billericia Reclamation Plant.....	671
Accuracy in Locomotive Repairs.....	673
Locomotive Air Brake Tester.....	677
Soft Grinding Wheels.....	678
Ted Symington—No Slacker.....	679
Wedge Block for Jacking Locomotives.....	680
Hydraulic Press for Shortening Drawbars.....	681
Full Day's Work for a Full Day's Pay.....	681
An Improvised Hydraulic Ram.....	682

NEW DEVICES:

Hose Mounting and Hose Clamping Machine.....	683
Inside Admission Piston Valve Chest for Slide Valve Cylinders.....	684
Arc Welding Tool with Positive Electrode Clamp.....	685
Milling Machine Vise.....	685

GENERAL NEWS:

Notes.....	686
Meetings and Conventions.....	688
Personal Mention.....	688
Supply Trade Notes.....	691
Catalogues.....	692

THE ANNUAL INDEX

For the purpose of conserving paper, only a sufficient number of indexes for the 1918 volume of the "Railway Mechanical Engineer" will be printed to meet direct requests from the subscribers. Those desiring indexes will therefore please send their requests on or before December 25 to the New York office, 2201 Woolworth Building.

**Improve
Air Brake
Maintenance**

The manner in which the maintenance of air brakes has been neglected has necessitated the issuance of various circulars by the Railroad Administration and others, urging greater care in this matter. The most recent appeal is that from the Master Car Builders' Association, which urges a closer observation of the interchange rules and the standards of the association. This appeal is printed in full elsewhere in this issue, with rules covering maintenance of triple valves and brake cylinders. It is hard to understand why air brake maintenance should have been allowed to be neglected, for certainly the air brake is a most important feature in successful train operation. Upon it depends the safety with which trains may be operated, the despatch with which traffic can be carried, and to no small extent, the amount of fuel required to conduct transportation. There has been evidence of gross neglect of inspection and repairs at terminals. Cases have been reported where a reinspection of a train showed a decrease of over 10 per cent in the number of operative brakes in a train. This is not only against the law, but is nothing short of criminal

neglect. Every effort must be made to bring conditions back to normal and at the earliest possible moment, for serious and expensive delays will result if this question is not given the attention it deserves.

**The Red Cross
Christmas
Roll Call**

It is unnecessary to call to the attention of our readers the remarkable work that has been done by the American Red Cross during the war. The Red Cross has always had the reputation of quickly getting to the scene of any great calamity and taking care of the sufferers. In pre-war times, the average person thought of the organization more in connection with hospital work than in any other capacity. During the great war, however, it has been active wherever there was suffering or need of help. Its work during the period of reconstruction promises to be as important, or even more important, than during actual warfare. Relief must be extended to those peoples that have been driven from their homes and who can now return to their native places and gradually re-establish themselves with the help that they may receive through the Red Cross. Then, too, the great problem must be faced of reclaiming those who have been injured and crippled. In the week beginning December 16, the American Red Cross is to hold a "Roll Call." This is not a drive for funds, but is rather an attempt to enlist every American, that is not now in the armed service of the United States, in becoming actively identified with the Red Cross movement which in the months to come will have to play a large part in the effort to repair the ravages and damages of the war and to supply the necessary aid to the thousands that may need it. The Red Cross needs the inter-

est and support of every red-blooded American and, on the other hand, every American citizen should feel honored in being identified with it.

Why Retain Long Pilots on Locomotives

The pilot is usually considered one of the unimportant parts of the locomotive and as a rule it receives but scant attention. An incident recently came to our notice that shows the necessity for giving some attention to the design of the pilot. On account of lack of space in the roundhouse a locomotive had been backed on a spur track. When it was to be put in the house it did not have steam enough to move. The pilot was so long that the switch engine which was to haul the locomotive out could not get it without bending the foot board, and it was necessary to make a trip to the yard, pick up a car, switch the locomotive into the house and set the car back in the yard. Inquiry developed that this awkward maneuver was of frequent occurrence.

In the early days of railroading in this country the pilot deserved the popular title of cowcatcher. Some roads still have trouble with live stock on the right of way but this is hardly sufficient reason for retaining the type of pilot used 50 years ago. Short pilots are as good if not better in clearing obstructions from the track. If the point of the pilot does not extend to the face of the coupler knuckle locomotives can be coupled with the pilots together, which is particularly desirable to facilitate handling on roundhouse tracks. Metal pilots are superior to wood as they can be made much stronger and if damaged usually require only to be straightened, while a wooden pilot which has met an obstruction is seldom worth repairing. The only explanation for the survival of the long wooden pilot seems to be adherence to custom. The short metal pilot is so obviously superior that it is hard to understand why its use has not become practically universal.

Uniform Engine Failure Reports

One important mission the Railroad Administration can perform before it passes out of existence is to formulate a code of rules to be used in the determination of engine failures and put it in force on all railroads under its jurisdiction. The chief purpose of the mechanical department is to provide adequate and well maintained equipment for carrying the traffic. The success with which it does this is measured by the amount of equipment kept in repair and the performance it gives on the road. In order to obtain an idea of the locomotive performance on two different roads, questions are asked frequently regarding the miles per engine failure. Under existing conditions this is highly misleading, for the definitions of engine failures and the degree of accuracy by which they are obtained are so much at variance that no fair comparison can be made. The Traveling Engineers' Association at its recent convention brought this point out clearly and its committee stated definitely what should constitute an engine failure. It recommended the following two definitions:

"1. All delays waiting for an engine at an initial terminal, except in cases where an engine must be turned and does not arrive in time to be despatched and cared for before leaving time.

"2. All delays on account of engines breaking down, running hot, not steaming well, or having to reduce tonnage on account of defective engine, making a delay at a terminal, a meeting point, a junction connection, or delaying other traffic."

These are supplemented by 13 items which should not be considered as engine failures, but which would not be needed if rule No. 2 were correctly interpreted. There are opportunities and temptations to charge an engine with a

failure when the delay may be due entirely to other causes, such as mishandling on the part of the crew, either engineer or fireman, excessive tonnage, weather conditions, or any of a hundred possible causes, any of which may result in poor engine performance and for which the engine or its condition is least of all responsible. The Mechanical Department of the Railroad Administration has unified the classification of locomotive repairs; it likewise should establish uniform classification of engine failures and provide some fair method of reporting them to eliminate the possibility of unjust charges.

Full Day's Work for a Full Day's Pay

There are two articles in this month's issue that bring out conditions in the shop labor situation, that are of special interest at this time. George N. De Guire, general supervisor of equipment for the Division of Operation, in an address before the men at one of the important shops, which is abstracted on page 681 of this issue, discloses the fact that deplorable conditions have existed in some of the shops in the eastern territory. In the particular shop at which this address was made he finds the effects of unrestricted development of the labor organizations, for he says, "I thought the government took over this railroad some time ago, but found that the employees, so far as this shop was concerned, were still running it." He cautions the men that the Railroad Administration will not stand for any such policy and says that, "Insubordination must cease, men must obey orders," and advises the shop management to get rid of the men in the shop who do not work the required number of hours, "For we cannot afford to tie up machines day after day waiting for some men who work only when they please." No shop can be efficiently managed where discipline does not obtain and discipline cannot be obtained unless the men realize that the penalty for insubordination is discharge.

On page 644 a correspondent writes of the "Doughboy" and the men who get the "dough!" He sounds a warning of what may happen to the shop man who "has just been drifting along in a 'don't care' sort of way" when the "Doughboys" come home and are looking for a job. The old, old law of supply and demand is still in operation and can never be annulled. With mechanics and laborers released from war work, and the soldier coming back to civil life, the man who does not give a full day's work for a full day's pay had better watch out.

Don't Overlook the Foremen

In the short period of 10 months in which the Railroad Administration has been free to develop and carry out its own policies, it has accomplished much that is admirable in dealing with the problem of wages and working conditions of railroad employees. It has secured justice for many groups whose claims have heretofore received comparatively little attention. There has been a tendency, however, to overlook the case of the salaried foremen and supervising officers of the mechanical department shops, repair yards and roundhouses. These men have long been underpaid and in addition to carrying the burden of responsibility incident to getting results with poor or indifferent facilities, have been required to be on the job many more hours than the forces which they supervise. No general leveling up of wages furnishes adequate remedy for this situation; unfortunately, many of the relative adjustments of compensation, and the general adoption of the basic eight-hour day and punitive overtime which have followed the general wage increase effected by General Order No. 27 and Supplement No. 4, have served to increase the disparity between their conditions and those of the men under their supervision. Attention is drawn to this situation by a corre-

spondent in a letter appearing on another page, in which he refers to a national organization of foremen recently formed, for the purpose of better presenting their claims to the Railroad Administration.

These men must not be overlooked. Although they do not constitute a large class, the effectiveness of the efforts of all the mechanical department forces depends in a large measure upon the ability, foresight and enthusiasm they bring to their tasks. If the exercise of these qualities is to be secured in full measure and the right material secured for the future, they must be accorded equal consideration with the wage earners.

Just what effect recent events will have on the policy of the Railroad Administration it is impossible to say and what will be the ultimate disposition of the agencies it has created is beyond conjecture. But it has the opportunity of performing a permanent service, long needed, for the welfare of the mechanical department by properly adjusting the relation of the conditions of employment of the foremen to those of the men who are now so well cared for.

Director General McAdoo Resigns

On November 22 Director General McAdoo tendered his resignation to President Wilson, to take effect January 1, 1919. During the slightly less than 11 months of government control of the railways Mr. McAdoo has wrought some extraordinary changes in railroad conditions and to an extent which will make it exceedingly difficult to return the roads to their private owners in the condition in which they were prior to being taken over by the government. Unfettered by binding federal laws, by the Interstate Commerce Commission and by the various state commissions, all of which have seriously hampered proper development of the railroads in the past, he has pooled facilities, completely rearranged traffic, and increased freight and passenger rates. This unlimited power has made possible the handling of a greater amount of traffic than was ever before handled by the railroads under private management, with but very little increase in facilities. This has been done, however, with an enormous increase in expense, primarily due to the increases in wages, which it is estimated will be between \$600,000,000 and \$800,000,000 for the year. Having done these things, which were impossible under private management and which will be impossible under future private management unless conditions change radically, it is plain to be seen that a sudden release of the railways to their private owners would result in grave consequences.

The problem is exceedingly complicated. The President admitted it in his discussion of the railroad problem before Congress on Monday, December 2. He says, "It is a problem which must be studied, studied immediately and studied without bias or prejudice." He has no suggestion for a solution. He points out three alternative courses, which in effect are: First, to release the roads and permit them to go back to the old conditions of private management; second, establish complete government control with actual ownership if necessary; or, third, to adopt an intermediate course of modified private control under which wasteful competition will be avoided and a certain degree of unification obtained, "as for example, by regional corporations under which the railways of definable areas would be in effect combined in single systems." He has placed the entire matter in the hands of Congress.

The clamor for actual government ownership is not now as great as during the early part of the year. To what extent this is due to the election of a Republican Congress, to the sentiments expressed against government ownership by the state commissioners at the convention in Washington, and to the resolution passed by the Industrial Traffic League, is hard to determine. The American railroads, the greatest in

the world, have been built up under private ownership and no other system holds out the same incentive to improve service, and to develop economies in operation. If the history of railroads operated under government control in other countries is any criterion, the railroads in this country would never have been developed as they have been if competition had been throttled by government control.

The heads of the railways have already begun to consider the problem. Representatives of 90 per cent of the railroads in the United States met on December 4 and defined desirable government regulation as that which "will provide unification of regulation in essential matters, insure business treatment of the vast interests involved, attract adequate capital and assure commercial, manufacturing and agricultural interests of the country transportation facilities which shall keep pace with their growing interests, and deal equitably with questions affecting wages and the working conditions of railroad employees."

What is to be done with the railways is one of the most important questions before this nation in its reconstruction plans. The matter is in the hands of Congress, the representatives of the people, and therefore in the hands of the people, and Congress must be guided by the will of the people.

NEW BOOKS

Economical Use of Coal in Locomotives. Prepared by the University of Illinois under the direction of a special committee, 71 pages, illustrated, 6 in. by 9 in., bound in paper. Published by the University of Illinois, Urbana, Ill., as Engineering Experiment Station Circular No. 8. Price 20 cents.

The Engineering Experiment Station of the University of Illinois has undertaken to prepare for users of fuel certain publications containing suggestions and advice relating to fuel conservation. The present circular has the purpose of helping railway officials and employees in their efforts to save coal. While it contains little that is new, it presents a simple statement of the facts concerning the choice, distribution, storage, and use of coal, and offers some conservative suggestions concerning the ways in which coal may be burned economically. The saving of a piece of coal the size of an ordinary egg on each scoopful of coal used in locomotives would amount to 1,500,000 tons a year. Even when firing a freight locomotive on a heavy grade, one less scoopful of coal every fifteen minutes, or one less scoopful every three or four miles, would effect a similar saving. A little more personal interest on the part of railway officials and employees will reduce coal consumption even on railroads where the practice is already excellent and where an earnest effort is being expended to save coal. A study of the practice in the use of fuel on the railways, however, discloses many means of effecting even greater economy. Colored illustrations are included in the pamphlet to show results of good and bad methods of firing. A clear discussion is given of the heat and coal distribution throughout the locomotive which is illustrated by well designed charts and pictures. The facts presented in this circular have been compiled by a special committee of the research staff of the Engineering Experiment Station, assisted by an advisory committee consisting of E. W. Pratt, assistant superintendent of motive power, Chicago and Northwestern; W. L. Robinson, fuel supervisor, Baltimore and Ohio; A. N. Willis, chairman, fuel committee, Chicago, Burlington and Quincy; Timothy Shea, acting president, Brotherhood of Locomotive Firemen and Enginemen; A. B. Garretson, president, Order of Railway Conductors of America; W. S. Stone, grand chief, Brotherhood of Locomotive Engineers; O. P. Hood, chief mechanical engineer on Fuel Conservation, U. S. Fuel Administration, and C. F. Richards, dean of the College of Engineering and director of the Engineering Experiment Station, University of Illinois.

COMMUNICATIONS

WORKING CONDITIONS OF MECHANICAL DEPARTMENT FOREMEN

ALBUQUERQUE, N. Mex.

TO THE EDITOR:

Just a word of thanks from railroad supervisory forces for the stand taken by your journal in support of adequate compensation for men on the railroads of the United States engaged in supervisory capacities.

There are organizations of the various branches of railroad employees, who have had representatives in Washington engaged in an earnest effort to have salaries raised for members of their respective branches. All have been represented except the foreman, general foreman, general inspectors and their respective assistants in the mechanical departments. All have received substantial concessions as to working conditions and salaries except those just enumerated. In order to properly bring before the Railroad Administration the claims of mechanical department supervisory forces, an Association of Railroad Supervisory Foremen was organized at St. Louis, Mo., on October 30, 1918.

Due to the combined efforts of your journal, and small independent committees representing the foremen interested, the question of salaries is being gradually adjusted to an equitable basis. There are other glaring defects in the working conditions of mechanical department supervisory forces which also need investigation with a view to correction. One of these, and more vital than the question of salary, is the twenty-four-hour day, and thirty-day month which 95 per cent of these men are required to adhere to.

Placing the supervisory forces of the men not included in the crafts—the clerical forces, the bridge and building and water service forces—on a basic eight-hour day, has resulted in officers figuring out where an eight-hour day for these men will be sufficient, and also has eliminated unnecessary Sunday work. In approximately 95 per cent of the various railroad shops and roundhouses in the country, it is found that on every Sunday practically all the foremen are on duty from three to twelve hours. They are most always dressed in their "Sunday clothes," just "hanging around," waiting (under orders) for some possible contingency to arise. The entire organization does not perform enough duties collectively to keep one of them busy all day. On this account very few foremen have what could be called a Sunday to themselves, to do with as they wish, at any time during the year, except possibly at regular vacation periods of fourteen days once a year.

One or possibly two of the foremen could take care of all the business. If each foreman was designated to be on duty his respective Sunday, to act as general foreman for that day, to take charge of and be responsible for the entire plant, it is easily seen that the excessive amount of time on duty could be reduced without impairing the operation of the railroads in the least. For instance, where there is a general foreman and eight craft foremen it would be only necessary for each one of them to be on duty every ninth Sunday. The experience gained by the respective foremen would be invaluable to both the railroad and the men when a chance for promotion came.

To sum up the respective orders and supplements, allow all the immediate supervisory forces of the Railroad Administration a basic eight-hour day and twenty-six-day month, except those of the locomotive and car departments. Were the supervisory forces of these departments placed on an eight-hour basis, it would naturally follow that depart-

ment officers would figure out how little overtime was necessary for these men to work in order to carry on the business. Now no attention is paid to the excessive number of hours on duty, and in some instances the monthly salaried men are expected to work more time in order to take the place of hourly rated assistant foremen.

As this is a vital question, and must come up for investigation, I hope you can give this communication space.

H. LOUIS HAHN,

Seventh Vice-president, International Association
Supervisory Railroad Foremen.

THE "DOUGHBOY" AND THE MEN WHO GET THE "DOUGH"

CHICAGO, Ill.

TO THE EDITOR:

Perhaps no class of men has received better consideration by the Railroad Administration, in point of wage increases and hours of labor, than those who are employed in the car and locomotive departments. The government while prosecuting the war made every effort to satisfy labor at home, and at the same time make the employment attractive from a remunerative standpoint.

It was no doubt the intention of the director general to stimulate the workers to greater output to meet the emergencies that the war had thrust upon the United States. That the major portion of these men have worked steadily and put in many long hours is a fact, as evidenced by their pay checks, and that men from other fields of labor have been attracted to this particular branch of railroad service is also true. To these two reasons—increased wages and an extra amount of help—may we attribute the success of meeting in a measure the needs of the times.

Now that our army is being demobilized and millions of the soldier boys will in course of time return to useful occupations of a constructive nature, many changes will become quite noticeable, and the fellow who had just been drifting along in a "don't care" sort of way will soon begin to slip. Why? Because our soldier boys in their intensive training have become hardened and full of the American spirit—better known as "pep." They have learned to sleep outdoors—at night before they slept they have seen the stars in the sky, and at dawn as they awoke they have heard the birds sing. They have learned from bitter experiences just what camouflage is; there will be no deceiving these boys. Upon their return they are going to demand of us the highest degree of efficiency. This is a force to be reckoned with.

Qualification is going to be a big factor when this huge force of reconstruction gets back to work, and it behooves each individual in these and other departments to take full advantage of every opportunity in order to measure up to the full requirements of his position. Economy of time and how best to use it should prove an important lesson to all of us. "Dost thou love life? Then do not squander time, for that is the stuff life is made of."—Franklin.

Our soldier boys have not been idle, they have read much and studied hard, and have been trained to use weapons of destruction, but to be used only against the common enemy of mankind—those who would oppress. Now the victory has been won and after the bitter hardships and experiences of warfare they are to return, work with us and live among us. As they relate their many but varied experiences of the "Doughboy" life, it is quite possible that those who worked at home and received the "dough" may soon forget and even blush at the thought of any real or imaginary grievances, but on the other hand may we not all become inspired with their enthusiasm to turn in and do our bit in the reconstruction period now before us?

Emerson wrote: "Man's life is progress, not a station."
Moral—Let us progress.

N. H. C.

LOCOMOTIVE FEED WATER HEATING

Discussion of the Exhaust Steam and Waste Gas Methods of Preheating for Locomotive Boilers

BY H. S. VINCENT

THERE are in the locomotive two sources of preheat available from which it is possible to derive economy, these are exhaust steam and waste gases. The former contains the greater quantity of heat and this heat is more readily transferred to the feed water, but as the exhaust jet is universally used for drafting the locomotive it is possible to divert only a limited amount of the steam for heating purposes. On the other hand from 20 to 45 per cent of the heat in the fuel escapes as waste gases through the smoke stack. This great loss would seem to offer a fertile field for economy, but on account of the slow rate of transfer between this heat and the feed water, as well as the practical difficulties in the way, little progress has been made in utilizing this waste.

It is the desire of the writer to point out the extent of the economies which may be realized from the preheating of feed water by the two systems mentioned as well as by a combination of these systems in series.

In order to present the matter in a way which may be readily understood the calculations have been based on an equipment suitable for application to a typical high speed passenger locomotive. The principal dimensions and characteristics of the locomotive selected are given herewith.

Cylinder diameter and stroke.....	27 in. by 28 in.
Driving wheels diameter.....	28 in.
Heating surface evaporative.....	4,436 sq. ft.
Grate area.....	69.2 sq. ft.
Boiler pressure.....	205 lb.
Tractive effort (85 per cent boiler pressure).....	44,500 lb.
Weight on drivers.....	202,880 lb.
Weight total engine.....	309,140 lb.
Indicated hp., maximum.....	3,184
Boiler hp., A. S. M. E. rating.....	2,534
Dry coal per sq. ft. grate, per hour max.....	170.5 lb.
Net cross sectional area, tubes and flues.....	1,321 sq. in.
Area exhaust nozzle.....	38.19 sq. in.

EXHAUST STEAM HEATING

Consider first the application to this engine of a feed water heater using a portion of the exhaust steam as the heating medium.

EFFECT ON THE NOZZLE AREA

The statement has been made that a portion of the exhaust steam may be diverted for heating the feed water without necessitating a reduction in the area of the exhaust nozzle. It can be demonstrated that this statement is not correct,

dependent upon the degree of smokebox vacuum, which varies with the pressure in the exhaust nozzle and passages. It is therefore evident that any decrease in the weight of steam passing through the nozzle, unless accompanied by a proportionate decrease in the amount of fuel consumed, will be detrimental.

Extensive tests made on the locomotive in question have proven this statement. In Table I will be found the amount of steam fed to the cylinders (Column 2),—the effective draft, or the difference between the draft ahead of the diaphragm and that in the firebox—(Column 3), the pressure in the exhaust passages (Column 4), for varying rates of fuel consumption (Column 1). Thus it will be seen that at a fuel rate of 120 lb. per sq. ft. of grate surface per hour, the

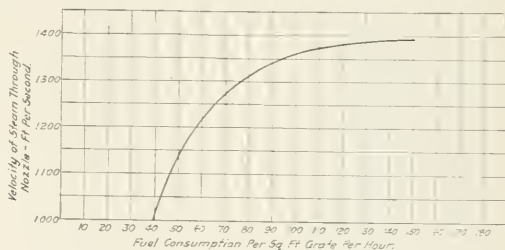

Fig. 1—Velocity of Steam Through the Nozzle for Different Rates of Fuel Consumption

effective draft is 11.8 in. of water, the amount of steam passing through the cylinders is 54,400 lb. per hour, and exhaust passage pressure is 13.7 lb.

It will be understood that the definite proportions as given in this table apply only to an engine having the characteristics shown above, however the principle involved applies to all locomotives.

Having this data, it is possible to determine the area of nozzle required to produce the necessary draft, when diverting a predetermined proportion of the exhaust steam.

$$M = \frac{FW}{V} \dots\dots\dots (1)$$

Where:

- M = Weight in pounds of fluid flowing past a given section per second.
- F = Area of given section in sq. ft.
- W = Mean velocity in feet per second of the fluid at the given section.
- V = Volume per unit weight (cu. ft. per lb.) of steam in exhaust nozzle.

TAKING THE PROPORTIONS FROM TABLE I:

$$M = \frac{54,400}{3,600} = 15.1 \text{ lb.}$$

$$F = \frac{38.19}{144} = .265 \text{ sq. ft.}$$

$$W = \frac{MV}{F} = 1,381$$

$$V = (13.7 - 14.7) \times 0.58 = 16.46 \text{ lb. corresponding to } 24.16 \text{ cu. ft.}$$

The pressure at the throat or the smallest area of the nozzle equals 58 per cent of the initial pressure, when the ratio of the final pressure to the initial pressure is less than that quantity.

Let *E* equal the kinetic energy of the steam escaping

TABLE I

1	2	3	4	5	6	7
Dry coal per sq. ft. grate per hour	Steam per hour	Effective draft, Ins. water	Pressure exhaust pas-sages	M	W	E
49	26,400	3.10	3.50	7.34	1,011	116,400
50	31,400	4.20	4.80	8.72	1,136	173,800
60	36,800	5.75	6.10	10.05	1,220	233,100
70	40,150	7.00	7.60	11.15	1,270	279,200
80	43,800	8.15	8.95	12.15	1,313	325,500
90	46,800	9.20	10.15	13.00	1,342	364,000
100	49,500	10.10	11.30	13.75	1,361	396,000
110	52,000	10.95	12.30	14.43	1,373	422,000
120	54,400	11.80	13.70	15.10	1,381	448,000
130	56,600	12.60	14.60	15.70	1,387	469,800
140	58,800	13.40	15.75	16.32	1,390	490,000
150	60,800	14.10	16.90	16.86	1,393	508,000

in fact locomotive tests have demonstrated beyond doubt the absolute interdependence of every element in the operation of the locomotive. For instance, every variation in the quantity of steam used requires a corresponding variation in the unit quantity of coal fired; the coal consumption is

through the nozzle, which is the force producing draft, then:

$$E = 0.5 \frac{M}{32.2} W^2 \dots\dots\dots(2)$$

$$E = 0.5 \frac{15.1}{32.2} 1,381^2 = 448,000 \text{ foot pounds.}$$

This is the force required per second to create an effective vacuum of 11.8 in. of water, when burning fuel at the rate of 120 lb. per sq. ft. of grate per hour.

It will now be assumed that 15 per cent of the steam passing through the cylinders is diverted for heating the feed water, this steam being taken from a point between the valve and the nozzle, at a pressure of 13.7 lb. per sq. in.; having this data it is possible to determine the area of nozzle needed to produce the required draft with the diminished weight of steam.

Table I, columns 6 and 7 give the quantities *W* and *E* for rates of combustion of 40 to 150 lb. dry coal per hour, when producing the weight of steam shown in column 2 and with the total quantity of steam produced passing through the nozzle. It is evident that if the same rate of evaporation and fuel consumption are to be maintained, with only 85 per cent of the steam passing through the nozzle; in order to

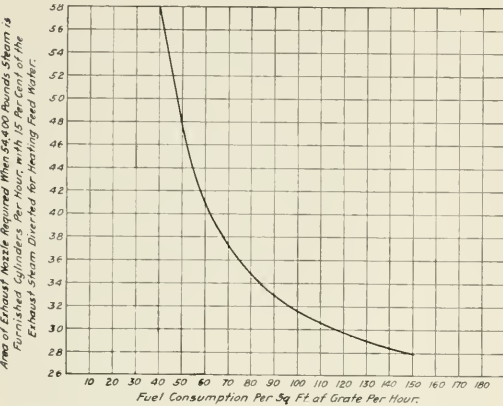

Fig. 2—Area of Nozzle in Square Inches for Various Rates of Combustion

maintain the same kinetic energy, the speed of the steam through the nozzle, or *W* must be increased.

$$\text{Let } M_1 = \frac{54,400 \times .85}{3,600}; \text{ } W_1 \text{ equal the required velocity of}$$

the steam, and *F*₁ equal the area of nozzle required to produce the necessary draft, then will

$$W_1 = \sqrt{\frac{E}{.5 \times \frac{M_1}{32.2}}} \dots\dots\dots(3)$$

$$F_1 = \frac{M_1 W_1^{1.44}}{W_1} \dots\dots\dots(4)$$

The values of *W*₁ and *F*₁, are shown by curves in Figs. 1 and 2 plotted over the unit fuel consumption. It will be seen from these diagrams that the area of the exhaust nozzle depends directly upon the economy given by the feed water heater, and that for this locomotive to require the original area of nozzle, the economy must be such as to reduce the unit fuel consumption to approximately 68 lb. per sq. ft.

Fig. 3 illustrates diagrammatically the type of exhaust steam heater in which the feed water circulates through the annular passages between the inner and outer tubes, the

heating medium flowing through the inner tube and surrounding the external surface of the outer tube. To provide sufficient volume the pipes are arranged in pairs, six such pairs or units forming the heater. The feed water is forced by a feed pump into the header at one end of the heater, it then flows in annular columns to the opposite header, traversing the entire length of the heater and flowing thence to the boiler. The heating medium (exhaust steam) is taken from any convenient point between the cylinder and the

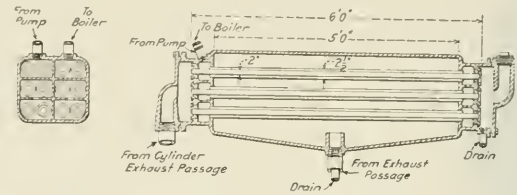

Fig. 3—A Type of Exhaust Steam Feed Water Heater

exhaust nozzle. It enters the heater at one end flowing through the twelve internal pipes to the opposite header, exhaust steam also enters the casing and surrounds the outer pipes, the condensate being carried to any convenient point.

For a heater of the dimensions shown in Fig. 3 the total traverse of the feed water is 30 ft. and of the exhaust steam in the inner channels, is approximately 6 ft.; the total heating surface in tubes is 71.22 sq. ft. As a modern boiler feed pump will deliver 100 lb. of water against a boiler pressure of 205 lb. for 1.75 lb. of steam, the total weight of water per hour passing through the heater is 54,400 × 1.0175 = 55,390 lb. or 15.35 lb. per second.

The volume per foot of the annular space between a pair

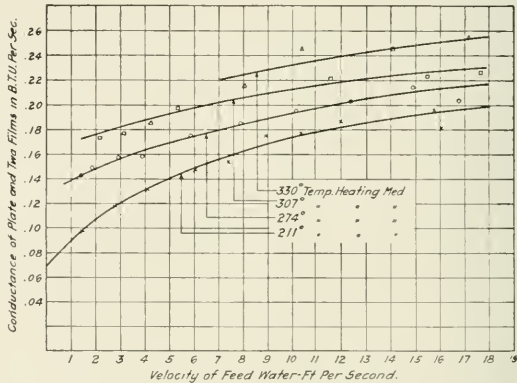

Fig. 4—Conductance Values at Different Temperatures at Various Feed Water Velocities

of tubes in the heater Fig. 3 is 26.96 cu. in. and the weight of water at 60 deg. is .972 lb. per foot of tubes. The velocity of water passing into the heater is $\frac{15.35}{.972} = 15.75$ ft. per second.

The pressure of the exhaust steam entering the heater is 13.7 lb. gage or 28.4 lb. (absolute) the corresponding temperature of saturated steam being 247 deg. F.

As the outlet or condensate pipe from the heater exhausts into the atmosphere, the heater is at all times under atmo-

spheric pressure, consequently while steam is present the mixture cannot fall below 212 deg. The temperature range of the heating medium is 247 deg.-212 deg. = 35 deg., and the average temperature through the heater is .5(247-212) = 230 deg.

To determine the amount of heat transmitted to the feed water in its passage through the heater it is necessary to consider the rate at which the heat flows through the tube

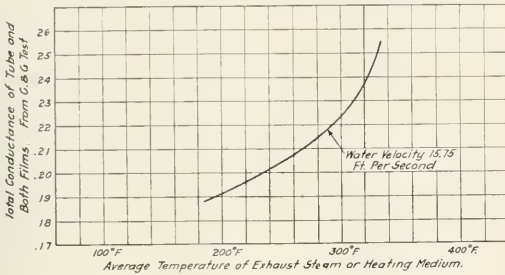

Fig. 5—Total Conductance for Various Average Temperatures at a Feed Water Velocity of 15.75 Ft. Per Sec.

walls. The experiment of Clement and Garland (Bulletin No. 40, Engineering Experiment Station, University of Illinois) affords valuable data on the transmission of heat from steam to water. In the flow of heat from a medium,

in B.t.u. per second, for the various temperatures of the heating medium obtaining in the test.

In diagram Fig. 5, a relation is established between the temperature of the heating medium and the total conductance. As the range and conditions of this test are fairly comparable with those which we have assumed for the present study, no great error can arise in accepting them.

We have found that the velocity of the feed water through the heater Fig. 3 is 15.75 ft. per second. Taking the intersections for this velocity from Fig. 4 and establishing the corresponding curve on Fig. 5, we find that for a velocity of 15.75 ft. per second the total conductance is .1985 B.t.u. per second per sq. ft. of heating surface, for each degree of temperature difference. As each lineal foot of the heater units contains 2.374 sq. ft. of heating surface; the total conductance per lineal foot equals $2.374 \times .1985 = .4712$ B.t.u. per degree of temperature difference between the heating medium and the feed water.

The heat transmitted by any given section of the heater may be determined by the equation:

$$Q = k^2 A hm \dots \dots \dots (5)$$

In which:

- Q = Heat transmitted in B.t.u. per second.
- k² = Coefficient of heat transfer, or conductance.
- A = Area in sq. ft. through which the transfer is in progress.
- hm = Mean temperature difference for the process.

Assuming that the feed water enters the heater at a temperature of 60 deg., corresponding to a thermal content of 28.08 B. t. u. and with the average temperature of the heat-

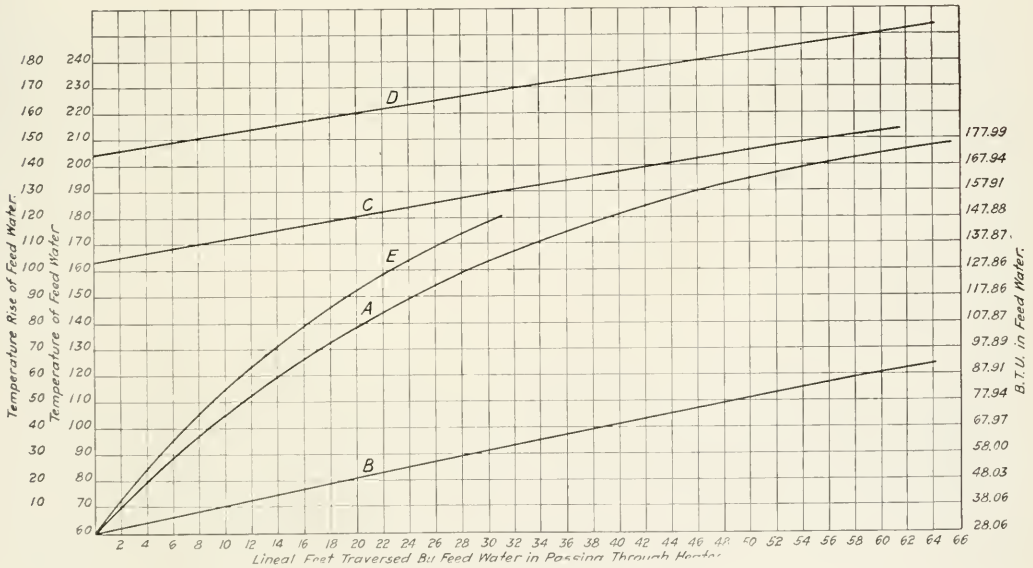

Fig. 6—Rise in Feed Water Temperature Per Lineal Foot of Feed Water Heater Pipes

gaseous or liquid, in contact with a metal plate, to a medium in contact with the opposite side of the plate there are three resistances to be overcome. These are the resistance of the film between the heating medium and the plate on one side, the resistance due to the metal of the plate, and the film between the plate and the liquid receiving heat.

From the data obtained by Clement and Garland, diagram Fig. 4 has been prepared, giving the relation between the velocity of the feed water in feet per second, and the total conductance of the plate and the two films

ing medium 230 deg., the heat absorbed per pound of water through the first lineal foot is given by the equation.

$$Q = \frac{k^2 A hm}{s w} \dots \dots \dots (6)$$

In which:

- s = Velocity of feed water in feet per second.
- w = Weight of water in one lineal foot of heater.

using the quantities found above:

$$Q = \frac{.1985 \times 2.374 \times (230 - 62.5)}{15.75 \times .972} = 5.16 \text{ B. t. u.}$$

Thus at the end of the first lineal foot the heat content of the feed water is $28.08 + 5.16 = 33.24$ B. t. u., corresponding to a temperature of 65.2 deg.

By a similar step by step process we find that at the end of 30 lineal feet, the heat content of the water has increased to 131.1 B.t.u. corresponding to a temperature of 163.3 deg., or a rise in temperature above feed water of 103.3 deg.

Fig. 6 curve A represents this rise in temperature and

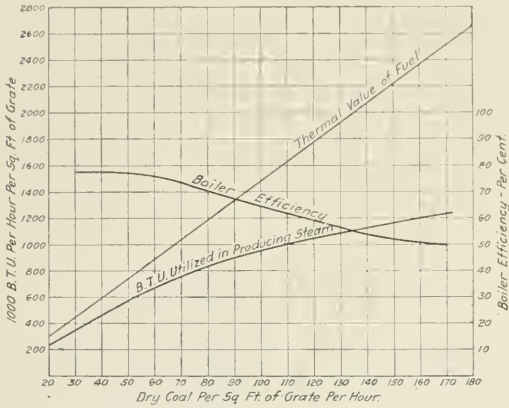

Fig. 7—Efficiency Curves of a Locomotive Boiler Without a Feed Water Heater

heat content, plotted in relation to the lineal feet in the heater, and illustrates the fact that as the temperature difference diminishes, the heat transfer between the steam and the feed water becomes proportionately less. If the heater contained 60 lineal feet, the heat content would be 172.27 B. t. u. and the corresponding temperature 204.03 deg., or a rise in temperature above feed water of 144.3 deg., an

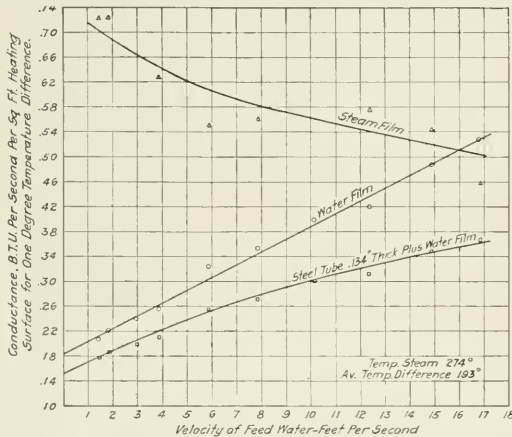

Fig. 8—Conductance Curves for Waste Gas Heater Tubes

increase of only 41 deg. in the last 30 ft. as against 103.3 during the first 30 ft.

For a heater having a traverse of 30 lineal feet, the heating medium in its passage through the heater has given up 103.08 B. t. u. by its temperature drop from 247 deg. to 212 deg. As the weight of steam passing through the heater per second is 2.265 lb. and the thermal value of one pound

at 247 deg. is 1,162.8 B. t. u., the total heat available per second is $2.265 \times (1162.8 - 180) = 2,227$ B. t. u. The heat absorbed by the feed water per second is:

$$\frac{.972 \times 30 \times 103.8 \times 15.75}{30} = 1,582 \text{ B. t. u.}$$

The heat remaining in the condensate is $2,227 - 1,582 = 645$ B. t. u., or 285 B. t. u. per lb. In other words, the dry steam will condense in the heater until the mixture contains 285 B. t. u. per lb. above the heat of the liquid, and will be discharged with this heat content, at a temperature of 212 deg. and at atmospheric pressure.

The total thermal content of the exhaust steam passing through the heater per pound of feed water is:

$$x = \frac{2,227 \times 30}{.972 \times 30 \times 15.75} + 28.08 = 173.58 \text{ B. t. u.}$$

This corresponds with a temperature of 205.6 deg. Reading from curve J on Fig. 6 it will be seen that this quantity of heat is absorbed by a heater of 61.6 lineal feet.

The direct economy is given by the following equation:

$$100 - \frac{H_1 - (H_2 - H_3)}{H_1} = \text{percentage of economy} \dots \dots \dots (7)$$

In which:

- H_1 = B. t. u. in steam at boiler pressure less B. t. u. in feed water.
- H_2 = B. t. u. absorbed by feed water in passing through heater.
- H_3 = B. t. u. per lb. of steam required for operating feed pump.

Applying this equation to a heater having a traverse of 30 lineal feet, we have a direct economy of:

$$100 - \frac{1,170.42 - (103.8 - 30.48)}{1,170.42} = 7.2 \text{ per cent.}$$

In addition to the direct economy,—or the reduction in the number of thermal units which the boiler must supply,—there is an indirect saving due to the diminished boiler losses resulting from the decreased fuel consumption. Fig. 7 gives the relation between the thermal value of the fuel fired and that utilized in the production of steam, in other words the boiler efficiency as determined from the tests of the locomotive. This boiler efficiency is plotted in relation to the unit fuel consumption per hour.

It has been shown that the locomotive not equipped with a heater consumes 120 lb. of dry coal per hour, per sq. ft. of grate surface when evaporating 54,400 lb. of water. With a heater of 30 lineal feet, the unit fuel consumption is:

$$\frac{120 \times 1.087.82}{1,170.42} = 111.5 \text{ lb.}$$

For the heater having 60 lineal feet, it is:

$$\frac{120 \times 1.046.71}{1,170.42} = 107.5 \text{ lb.}$$

Referring to Fig. 7, for a unit fuel consumption of 120 lb., the boiler efficiency is 59 per cent, and for a unit consumption of 111.5 lb., an efficiency of 61.6 per cent, an indirect economy of $61.6 - 59 = 2.6$ per cent, which added to the direct saving as found above, gives a total economy of $7.2 + 2.6 = 9.8$ per cent.

Similarly we find that with a unit consumption of 107.5 lb., the boiler efficiency is 62.5 per cent, and the indirect economy equals 3.5 per cent, with a total economy of 14.2 per cent for the heater having a traverse of 60 lineal feet.

This is the maximum economy obtainable with the heater in Fig. 3 when diverting 15 per cent of the exhaust steam.

In a paper read by George M. Basford, as reported in the Journal of the American Society of Mechanical Engineers, for September, 1917, a design of feed water heater is illustrated, in which the feed water passes in a thin film between two spirally corrugated copper tubes. The statement is made that heat transfers greater than 900 B. t. u. per sq. ft. per hour per degree of temperature difference have been obtained with this device.

The value K or the conductivity of the steel tube as ex-

perimented with by Clement and Garland is 48.36 B. t. u. The value of *K* for copper as given in Marks' handbook is 220 B. t. u. Using the same thickness for the copper tube as for the steel tube experimented with, the conductance of the former is:

$$\frac{220 \times 1.204}{48.36} = 5.48 \text{ B.t.u.}$$

The conductance of the steel tube is 1.204 B. t. u. We can combine this conductance with that of the two films as established by Clement and Garland, by taking the value shown in Fig. 8 for a water velocity of 15.75 ft. per second.

It will be observed that the curve for the conductance of the water film is approximately a straight line; while the curve for the combined conductance of tube and film drops away as the velocity of the water through the tube is increased; indicating that the conductance of the metal in the tube is not constant for all velocities.

Reading the values from the diagram, we have:

$$\frac{1}{\frac{1}{.354} + \frac{1}{.505}} = 1.184 \text{ B.t.u.}$$

This gives the conductance of the metal in the tube at the given velocity of the feed water. Assuming that the con-

ductance of the copper tube will decrease with the velocity in the same ratio, we have as the conductance:

$$\frac{1.184 \times 220}{48.36} = 5.39 \text{ B.t.u.}$$

Combining this conductance with that of the film, we have:

$$\frac{1}{\frac{1}{.505} + \frac{1}{5.39} + \frac{1}{.512}} = .243 \text{ B.t.u.}$$

The conductance in B. t. u. per sq. ft. of heating surface is then, $.243 \times 3600 = 875$, this agrees very closely with the figure given by Mr. Basford, or 900 B. t. u.

Using the latter figure, we have $\frac{900}{3,600} = .25 \text{ B. t. u. con-}$

ductance; substituting this value in equation (6), we have for the heater Fig. 3 with 30 lineal feet traverse, a final temperature of 178.05 deg. with a thermal content of 145.93 B. t. u. This increase in temperature is illustrated by curve *E* in Fig. 6. From the figures given it would seem that the increased efficiency of the heater shown by Mr. Basford is due chiefly to the higher conductance of the metal used.

(To be Continued.)

A. T. & S. F. 4-8-2 TYPE LOCOMOTIVES

Heaviest of the Type Yet Built; Two of Similar Design, Differing in Detail and in Fuel Used

IN JUNE, 1918, the Atchison, Topeka & Santa Fe received from the Baldwin Locomotive Works, two Mountain type locomotives for use in passenger service, which are designed to develop 54,100 lb. tractive effort. These engines bear the road numbers 3700 and 3701, and although they are generally similar in design there are a number of differences in the details. Engine 3700 is fitted for coal burning service and has the Baker valve gear, while engine 3701 burns oil and is equipped with the Walschaert valve gear.

velop a tractive effort of 57,200 lb. A comparison of the dimensions of the Santa Fe locomotives with those of other notable 4-8-2 type locomotives is presented in the table.

Using Cole's ratios as a basis of comparison, the Santa Fe locomotives have ample evaporative capacity, the boiler being something over 100 per cent in this respect. The grate, however, is relatively small, and has a rating of only 87 per cent. In other words, the development of the maximum horsepower which should be obtained from cylinders of the

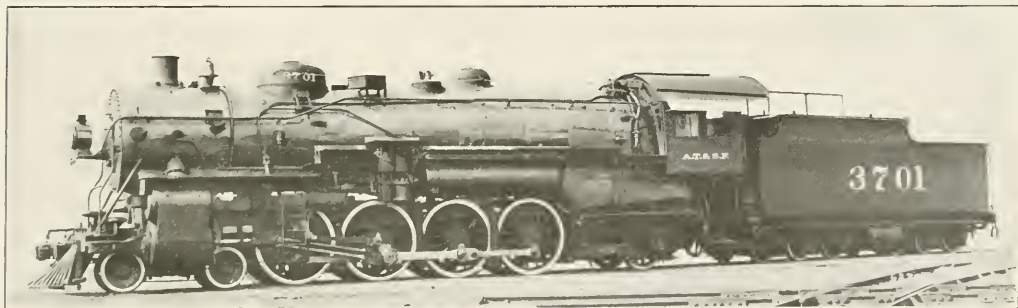

One of the Two Mountain Type Locomotives Recently Built for the Atchison, Topeka & Santa Fe

There are other differences which will be referred to later.

The proportions of these locomotives as a whole compare favorably with any of the same type which have been built heretofore. They are the heaviest of the type thus far built and with one exception have not been exceeded in tractive effort by any 4-8-2 type locomotives having driving wheels of equal or greater diameter. The locomotives built by the Norfolk & Western in 1916, with drivers and cylinders each one inch larger in diameter than the Santa Fe engines, de-

size employed on these engines, at the rate of 3.5 lb. of coal per horsepower-hour, will require an hourly combustion rate of 138 lb. per sq. ft. of grate instead of the 120-lb. rate on which Cole's ratios are based. The New York Central locomotives referred to in the table have a 98 per cent boiler, with a slightly higher grate rating, and the Norfolk & Western locomotives have a boiler between 80 and 90 per cent, with a 90 per cent grate.

Apart from the changes incident to the use of different

fuels, the boilers of the two Santa Fe locomotives are alike. A conical ring is placed in the middle of the barrel, increasing the shell diameter from 82 in. at the front end to 96 in. at the throat. The firebox has a combustion chamber 45½ in. long, and arch tubes are used in both the boilers. An arch is fitted in the coal-burning locomotive, which is fired with a Duplex mechanical stoker and is equipped with power-operated grate shaker and fire door. On engine 3701 the standard arrangement of Santa Fe oil-burning equipment, with Booth burner, is used. The superheaters are of the same size as those used in the Santa Fe 3160 class Mikado type locomotives.

Flexible staybolts are applied in the breaking zones in the sides, back and throat of the firebox, and in the sides and bottom of the combustion chamber, while four rows of expansion stays support the forward end of the combustion chamber crown. In the case of such of the expansion-stays

interchange with those of the 3160 class Mikados. The rear frame is of the Commonwealth cradle pattern, and in this case is used in combination with the Delta trailing truck. Locomotive No. 3700 is equipped with a leading truck of the Economy constant resistance type, while the leading truck of No. 3701 has three-point suspension swing links and a one-piece, cast steel frame in lieu of a frame of the built-up design generally used.

The guide-yoke and valve motion bearer of each locomotive are braced to the boiler by heavy wrought iron rods having jaws on their upper ends which are pinned to brackets studded to the boiler shell. These brackets are fitted against external liners riveted to the boiler shell. Ample strength is thus provided in a vertical direction, while provision is made for lateral movement due to the expansion and contraction of the boiler shell.

The tenders have six-wheel trucks and one-piece, cast-steel frames and the details interchange with those of the Mikado type locomotives previously mentioned.

Although these locomotives represent a type that is new to the Santa Fe system, and are in a certain sense experimental, their design is based on that of locomotives which are giving satisfactory results on this road, and no radically new features are embodied in their construction. Few railways in this country present more difficult operating conditions than the mountain divisions of the Santa Fe, where there is an excellent field for demonstrating the capacity and efficiency of the Mountain type locomotives in general, in heavy passenger service.

The table which follows presents the principal dimensions and data pertaining to these locomotives:

COMPARISON OF PRINCIPAL DIMENSIONS OF NOTABLE 4-8-2 TYPE LOCOMOTIVES

Road	Santa Fe	N. Y. C.	N. & W.	C.R.I.&P.
Year built	1918	1916	1916	1913
Tractive effort, lb.	54,100	50,000	57,300	50,000
Total weight, lb.	353,900	343,000	341,000	333,000
Weight on drivers, lb.	227,700	234,000	236,000	224,000
Cylinders, in.	28 by 28	28 by 28	29 by 28	28 by 28
Boiler pressure, lb. per sq. in.	200	185	200	185
Diameter of drivers, in.	69	69	70	69
Evaporating heating surface, sq. ft.	4,790	4,430	3,984	4,117
Superheating surface, sq. ft.	1,086	1,212	882	994
Grate area, sq. ft.	71.5	66.8	80.3	62.7

as cannot be placed radially with relation to the outside shell, bosses are electrically welded to the roof sheet in order to provide a sufficient number of threads for the staybolt sleeves.

The main dome is located immediately in front of the combustion chamber, while the auxiliary dome is farther forward on the conical ring. This dome is placed on the left-hand side of the boiler over a 17-in. opening, the center of which is 14 in. from the longitudinal boiler center. The opening thus clears the dry pipe, and permits easy entrance to the boiler for inspection purposes.

The dynamic augment in rail pressure due to the effect of the counterbalance, is kept within reasonable limits by using comparatively light reciprocating and revolving parts made of special materials. The piston heads are steel castings of dished section, while the piston rods, main rods, side rods and main crank pins are of Nikrome steel. The piston rods are of the extended type. The crossheads interchange with those of the 3160 class Mikados and are of the Laird type, with comparatively light bodies of .40 per cent carbon steel. Fifty per cent of the weight of the reciprocating parts is balanced. The driving-wheels are fitted with Mansell tire retaining rings.

Locomotive No. 3700, with the Baker valve motion, is equipped with piston valves of the Santa Fe standard design and with the Ragonnet type B power reverse mechanism; while locomotive No. 3701, which has the valves operated by the Walschaert motion, is equipped with the American Balanced Valve Company's piston valves and the Lewis power reverse gear.

The running gear details include several features of interest. The main frames have a width of 5½ in. and the upper and lower frame rails between adjacent pairs of driving pedestals are united by vertical ribs, which are cast in one piece with the frame and greatly increase its strength in a vertical direction. These ribs support the equalizing beam fulcrum pins. The frames are braced transversely at each pair of driving pedestals and also midway between the pedestals. Long journals with driving boxes of the Cole type are used on the main driving axle and the shoes and wedges

General Data

Case	4 ft. 8½ in.
Service	Passenger
Fuel	Oil, soft coal
Tractive effort	54,100 lb.
Weight in working order	353,900 lb.
Weight on drivers	227,700 lb.
Weight on leading truck	65,700 lb.
Weight on trailing truck	60,500 lb.
Weight of engine and tender in working order	587,600 lb.
Wheel base, driving	48 ft.
Wheel base, total	39 ft. 5 in.
Wheel base, engine and tender	76 ft. 8½ in.

Ratios

Weight on drivers ÷ tractive effort	4.2
Total weight ÷ tractive effort	6.5
Tractive effort × diam. drivers ÷ equivalent heating surface*	581.5
Equivalent heating surface* ÷ grate area	89.8
Firebox heating surface ÷ equivalent heating surface*, per cent.	5.8
Weight on drivers ÷ equivalent heating surface*	35.5
Total weight ÷ equivalent heating surface*	55.1
Volume both cylinders	19.9 cu. ft.
Equivalent heating surface* ÷ vol. cylinders	322.6
Grate area ÷ vol. cylinders	3.6

Cylinders

Kind	Simple
Diameter and stroke	28 in. by 28 in.

Valves

Kind	Piston
Diameter	15 in.

Wheels

Driving, diam-ter over tires	69 in.
Driving, thickness of tires	3½ in.
Driving journals, main, diameter and length	12 in. by 20 in.
Driving journals, others, diameter and length	11 in. by 12 in.
Engine truck wheels, diameter	33 in.
Engine truck, journals	7 in. by 12 in.
Trailing truck wheels, diameter	47 in.
Trailing truck, journals	9 in. by 14 in.

Boiler

Style	Conical wagon-top
Working pressure	200 lb. per sq. in.
Outside diameter of first ring	82 in.
Firebox, length and width	122½ in. by 8½ in.
Firebox plates, thickness	Sides, back and crown, ¾ in.; tube, ½ in.
Firebox, water space	Front and sides, 5 in.; back, 4½ in.
Tubes, number and outside diameter	253—2¼ in.
Fires, number and outside diameter	43—5½ in.
Tubes and fires, length	21 ft.
Heating surface, tubes and fires	4,416 sq. ft.
Heating surface, firebox, including arch tubes	374 sq. ft.
Heating surface, total	4,790 sq. ft.
Superheater heating surface	1,086 sq. ft.
Equivalent heating surface*	6,419 sq. ft.
Grate area	71.5 sq. ft.

Tender	
Tank	Water bottom
Frame	Cast steel
Weight	233,700 lb.
Wheels, diameter	33 in.
Journals, diameter and length	5½ in. by 10 in.
Water capacity	12,000 gal.
Oil capacity	4,000 gal.

*Equivalent heating surface = total evaporative heating surface + 1.5 times the superheating surface.

SUPERHEATER LOCOMOTIVE PERFORMANCE*

Superheating as adapted to locomotive service established itself as practical, simple and economical several years ago. So much evidence has been presented from time to time, showing the benefits derived from superheating, that the case is well proven, and further substantiation here is out of place. Our problem is one of maintenance and operation, one of getting full measure of return out of the 25,000 superheater locomotives in service in the United States. They are capable of returning or saving 20 per cent to 25 per cent in coal per unit of work done; they are capable of doing 25 per cent to 30 per cent more work per locomotive than similar saturated steam locomotives, either by hauling heavier trains at given schedules, or given trains at faster schedules. These are positive and direct returns that have been established under day by day operating conditions and are to be expected at all times.

Now, more than any time in the past, is it imperative that locomotives should be kept in a condition to sustain 100 per cent operating load. Every hour of high priced labor must be made to produce the most, and not wasted in working out some uncertain guess. In the same way every pound of expensive material must be made to earn its high cost; that is, locomotives should leave the freight yard fully loaded to a rating of higher authority than that provided by the ability of a poor fireman. The emergency of the times demands that full measure be returned from every unit employed. Incompetence and carelessness have no place in the present emergency. Locomotives must be operated and maintained by those who *know* and who *will*. The full measure of the superheater locomotive is 100 per cent of its rating at all times on a minimum consumption of coal and water.

To illustrate more clearly what is meant, the committee takes the liberty of abstracting a recent paper by C. M. Darden, read before the Southern & Southwestern Railway Club. Tests of a Mikado type locomotive developed that a change of 3/8 in. in the diameter of the exhaust tip increased the firebox temperature about 400 deg. by increasing the draft, thereby providing more complete combustion, with a resultant saving of \$57,000 in coal per year. The locomotive seemed to be performing satisfactorily before the change, with no complaint from the crew. Adjustment in the valve gear showed an increase of 7.8 per cent in drawbar horsepower; thus permitting this locomotive to haul the same tonnage at a higher sustained rate of speed or a proportionate increase in tonnage rating at the same rate of speed. There are several engines of this type in the same class, which multiplies the benefit to the railroad.

Similar investigation of a Ten-wheel locomotive which had been converted by the application of a superheater, indicated changes which, when carried out, improved the coal economy 9.8 per cent and also resulted in making up 34 min. on a schedule previously involving delays of over 50 min. The engine is now hauling three additional cars and burning less coal.

Parts of superheater locomotives which may affect economy should be very carefully watched for proper size and

adjustment. Air openings in ash-pans on many locomotives are insufficient. Grate designs are not adaptable to the kind of fuel burned. Exhaust nozzle size and location bear a direct relation to fuel economy. Front end arrangement and adjustment, with special attention to the prevention of steam or air leaks, furnish opportunity for improvement in many cases. Stack design, size and location, can be given closer attention with profitable results. Many other items might be enumerated constituting things that it is more convenient to get along with than to correct, as the engine probably runs satisfactorily to those who do not have the owners' interests particularly at heart. Attention to them, however, would increase the earning power of the machine for the operators and move more freight.

Just as any machine requires care and attention to keep its production at a maximum, there are certain fundamentals in maintenance and operation which are essential to the 100 per cent performance of the superheater locomotive. They are easy to comprehend and simple to carry out, but to insure 100 per cent performance they must be kept constantly in mind and continuously carried out by both shop and enginemen.

IMPORTANCE OF CORRECT MAINTENANCE

Correct maintenance in the back shop and the engine house is essential to the best operating results on the road. Unless a locomotive is turned out in first-class condition, first-class performance, from an operating standpoint, cannot reasonably be expected from it. The superheater requires a minimum of attention to keep it in good condition. If it is not given this attention, the superheater *may* be injured; but the performance of the locomotive certainly *will* be injured.

CLEAN FLUES

Examine a piece of metal that has been lying in a bed of cinders and note the corrosion that has taken place. Imagine that there is added to this corrosion the effects of the high temperature reached by cinders, soot and clinkers, which are lying in a boiler flue, and you will have an idea of the



Distorted Ends of Superheater Units, One Result of Stopped-Up Flues

conditions imposed upon superheater units when the flues are not kept clean. A continuation of these conditions is likely to result in burned and warped unit pipes, and burned-off unit bands and supports, permitting the unit to vibrate in the flue. Sooner or later this will necessitate repairs to the superheater, which will require the locomotive to be held out of service. This might be called the indirect result of not keeping the flues clean; the direct result is the shutting off of part of the hot gases from reaching the superheater units and also the evaporative surface of the flue; the amount of superheat in the steam falls off and the effective performance of the locomotive is reduced. If the flue becomes

*Abstract of committee report presented at the 1918 convention of the Traveling Engineers' Association.

completely stopped up, the effect is aggravated. One large flue of a 25-unit locomotive superheater stopped up in this way, reduces the capacity of the superheater 4 per cent and the total superheating capacity falls off 4 per cent more for every additional plugged flue.

There should be no need of a remedy for this condition; what is required is a preventative. Thorough, systematic, regular cleaning of all flues, large and small, obviates the difficulties resulting from plugged flues. Spasmodic, half-hearted poking with a rod at one or two flues which appear to be the worst is not flue cleaning. Correct flue cleaning must be a matter of shop routine. Don't wait to clean the flues until there is a steam failure and a delayed train. Keep them clean all the time and prevent the failure. It is not only the cheapest in the long run, but it is the easiest. To knock a little clinker off one or two units, and blow a small accumulation of soot and cinders through into the front end with a $\frac{3}{8}$ -in. pipe on the end of an air hose is a small job. However, with 15 or 18 large flues and 40 or 50 small ones plugged solid with cinders for several feet and the cinders embedded around the superheater units so that a bar has to be used to loosen them, the job of flue cleaning assumes considerable proportions. It is prevention that is needed; not cure.

MAINTAINING SUPERHEATER UNITS

There are two main considerations bearing on the maintenance of tight joints between the superheater units and the header; correct grinding of the unit ball ends and their seats in the header; and the quality of the material and manufacture in the unit clamp bolts. It must be borne in mind that while the unit end is spherical, with a radius of 1 1/16 in., the header seat is not spherical, but conical, with an angle of 45 deg. The ball end, when correctly ground, has a line bearing of 1/32 in. to 3/32 in. wide in the header seat.

In repairing these joints, it is seldom necessary to remove any metal with a cutting tool, unless the seats are scored or cut, and then only enough metal should be removed to true up the seats. In the great majority of cases, a light grinding with the soft metal grinding process will restore both the header seats and the unit ends to a good bearing. With correct grinding of these seats, the key to tight joints lies in the unit clamp bolts. These should have a tensile strength of not less than 100,000 lb. per sq. in., and an elastic limit of not less than 75,000 lb. per sq. in., and the nuts must be capable of developing the full strength of the bolt. When bolts of ordinary iron, of low tensile strength are employed, the material has not the necessary strength to resist the force applied by a man in setting up the nuts with a wrench, so that the bolt stretches, the ball end does not seat tightly in the header, and a steam leak results.

The bands and supports which hold the unit pipes together and the unit in its place in the flue are important factors in maintaining tight joints at the header. The supports not only hold the pipes together, but support the unit in its correct position in the flue. The correct application of bands and supports is vitally important. If bands are applied where supports should be, the unit will not be supported firmly in position clear of the walls of the flue, but will lie on the bottom and vibrate when the locomotive is in motion. This vibration places a strain on the joint at the header and may result in steam leaks at this point or in damage to the unit pipes.

The effects on locomotive performance of steam leaks in the front end need not be dwelt upon; they are familiar to any one who is familiar with the locomotive and are easily prevented by giving them proper attention in shops and engine houses.

DAMPERS

Consider for a moment what happens in the locomotive with a hot fire in the firebox if the crown-sheet is permitted to become dry. A similar condition exists with the units when the throttle is closed in a superheater locomotive which has no damper. The same condition applies when the throttle is closed and the damper has been fastened in the open position. When the throttle is closed, steam ceases to flow through the superheater units and there is then nothing to absorb any heat which may be delivered to the unit pipes. If the hot gases continued to flow through the large flues, particularly with the locomotive drifting at high speed, the units would become overheated. While damage might not be evident after a single occurrence of this kind, continued overheating will break down the structure of the material and damage the units.

The location of the damper in the smokebox is such that it controls the flow of gases through the large flues, and when the throttle is closed the damper automatically shuts off the flow of gases through these flues and protects the superheater. When the throttle is opened, steam is automatically supplied to the damper cylinder and the damper opens. In switching locomotives, where the boiler is very generally in use when the throttle is closed, it has been found desirable to operate the damper with steam from the blower, and the damper is then normally open except when the blower is in use.

The damper mechanism is very simple and requires but little attention to keep it in good working condition. Given that little attention, it performs its functions and aids materially in securing the best performance from the locomotive. A most pernicious practice is that of fastening the damper in the open position. This practice completely defeats the object of the damper. The damper, properly installed, offers no interference to the draft, and attention to its few maintenance requirements insures its continuing to function correctly. Fastening the damper in the open position to correct a bad steaming condition that is due to neglect of flue cleaning removes the protective feature from the superheater units and does not remove the cause of the trouble. There is nothing to be gained from this practice and the locomotive's performance may be seriously affected because of damage to the superheater units.

Freezing of damper cylinders, sometimes the cause of difficulty in cold weather, is easily prevented by thoroughly lagging both the steam supply and the drain pipes. These pipes should be free from pockets which would permit the collection of moisture.

THE EFFECTS OF HIGH WATER

The economies resulting from the use of superheated steam depend on the temperature to which the steam is superheated. Steam with 250 deg. of superheat will give better results than steam with 150 deg. The superheater will evaporate water; but it cannot do so and at the same time superheat steam. Acting on the assumption that the water level can be carried at the top of the glass in a superheater locomotive, is putting the superheater to work as an auxiliary evaporator or boiler. Water cannot be superheated; it must first be turned into steam, and every square foot of surface that the superheater gives up to the evaporation of water, carried over through the throttle and dry pipe, is lost from the purpose of superheating. Carrying the water at a level which results in priming reduces the superheating capacity of the superheater and injuriously affects the locomotive's performance.

This practice has another bad effect. As a boiler accumulates scale, so does a superheater when it is made to do a boiler's work. The scale formation in the superheater units may become thick enough to insulate the steam pass-

ing through the units so that it cannot absorb the necessary heat from the pipes, and again the locomotive's performance will fall off.

In the operation of superheater locomotives, the water should always be carried as low as the service conditions will permit. It should be impressed on hostlers and others who move locomotives around shops and terminals that flooding the boiler is bad practice. It will result in water going over into the superheater under conditions favorable to the formation of scale; it also encourages leaky units, both of which are followed by a falling off in the performance of the locomotive when it is on the road.

LUBRICATION AND DRIFTING

The successful lubrication of superheater locomotives presents no very difficult problem. Careful study of conditions will generally indicate their cause and suggest means of overcoming it. So-called carbonization of oil in the cylinders is caused by the admission of air when the cylinders are at temperatures above the flash point of the oil and by unconsumed gases being drawn into the valve chambers and cylinders through the exhaust. The practice of drifting with a slightly opened throttle should always be followed. The use of oil having a flash point above the temperature of the steam is also recommended. Experience has demonstrated that the admission of oil to the valve chests only does not provide the necessary lubrication for the cylinders as satisfactorily as when oil is fed directly to them.

A very important consideration in the lubrication of superheater locomotives is the fitting of piston and valve rings. The material used in bushings and rings should be of the best; and the rings should fit the walls and not too tightly. The bore of a cylinder or valve chest, when new, is round, and the rings should be turned round to fit the bore. Turning the rings too large, and then cutting a piece out and springing them into place results in an oval ring in a round cylinder.

Experience has demonstrated that careful fitting of rings of a good grade of material; the use of the throttle, open slightly, when drifting; and the delivery of oil directly to the cylinders as well as to the valve chests will prevent lubrication troubles on superheater locomotives.

THE PROBLEM AND ITS SOLUTION

Clean flues, dampers in good operative condition, units well maintained, water carried at the right level—all of these *must* be. And they *can* be, easily, if every one will do his share. *Prevention* must be borne in mind and acted on by all. There is no other machine of which it is more true than of the locomotive that "an ounce of prevention is worth a pound of cure." *Prevent* plugged flues by cleaning them regularly, when cleaning them is only a little job; *prevent* disabled dampers and damaged units by reporting and having completed the *little* jobs; carry the water at a reasonable level and *prevent* a loss in superheater capacity; drift with the throttle cracked and *prevent* lubrication difficulties. *Prevention* is easy and economical. *Cure* is difficult and expensive; it means overtime, delay and loss of service engine-hours.

The items that have been considered for the most part pertain in particular to the superheater, but the importance of other things must not be overlooked. Correct steam distribution, absence of steam leaks, good maintenance of machinery and proper drafting are all matters of as vital importance to the superheated as to the saturated steam locomotive. But in these, as well as in those features which are more closely related to the superheater, the policy of prevention by overcoming small difficulties when they *are* small, is the simplest and easiest way to produce the results which must be obtained. On the roads which followed this

policy, there was a minimum of difficulty experienced last winter. Their example lies before us and all must begin to profit by it now in order to realize the best performance from the superheater locomotive during the winter ahead.

The report was signed by Joseph Keller (Lehigh Valley), chairman, Frederick Kerby (Baltimore & Ohio), Hugh Gallagher (Atchison, Topeka & Santa Fe), J. A. Cooper (Erie), and W. A. Buckbee (Locomotive Superheater Company.)

DISCUSSION

Joseph Keller, chairman of the committee, after reading the report spoke of some tests that were made regarding the lubrication of superheater locomotives which were not completed in time to be included in the report. A vacuum gage was applied to the valve chamber at the point where the relief valve is usually located, to determine the amount of vacuum obtaining under varying conditions. The tests were made on Pacific and Mikado locomotives having a 1-in. and a 1½-in. steam pipe leading to the cylinders for the purpose of admitting steam while drifting. In a test at 45 m. p. h., with the drifting valve wide open, the vacuum varied from 26 to 36 per cent. With the valve closed it increased to 50 and 66 per cent. In some cases a vacuum of about 80 per cent was obtained with the drifting valve closed. In every case the amount of vacuum was considerably greater with the drifting valve closed than when the steam was being admitted to the cylinders through the drifting valves. This indicated that regardless of the fact that drifting valves are used there is an opportunity for the cylinders to suck in gases from the smoke-box. An analysis of the carbonization found in the valve chamber of the Mikado locomotive showed that 27.72 per cent was oil matter, 23.17 per cent was iron and 59.11 per cent was coke. This shows that the walls are abraded and iron fillings contribute to the carbonization matter. It also shows that some of the smoke is drawn back through the exhaust nozzle. These tests indicate the necessity of preventing a partial vacuum forming in the cylinders.

F. P. Roesch, fuel supervisor of the Railroad Administration, spoke of some tests made on the El Paso & Southwestern in which it was found that it required a 2-in. steam pipe to keep the cylinder drifting valves closed while the locomotive was drifting, and that the supply of steam for this purpose was very large. He suggested that steam be admitted to the exhaust side of the piston in an endeavor to break the vacuum and at best to dilute the gases drawn into the cylinders. As an example of this he referred to the operation of the old time water brake. He spoke of the necessity of properly maintaining superheaters and of the importance of not carrying the water in the boiler too high. He told of having found superheater units "repaired" by plugging them at the header with blind gaskets. This is, of course, bad practice and should not be tolerated.

F. Kirby, Baltimore & Ohio, called attention to the fact that a leaky front end door or steam pipe will greatly affect the efficiency of the superheater. He was very much in favor of the use of pyrometers in order that the engine crew may better watch the performance of the locomotive. It also gives an indication of the condition of the locomotive. If the proper degree of superheating is to be obtained, the efficiency of the locomotive will be greatly diminished by keeping the water too high in the boiler. This not only reduces the efficiency of the superheater but injures the superheating joints. The hostler is responsible for a great deal of this trouble. The proper level for the water should be found and marked on the glass. In commenting on cylinder lubrication he has found by tests that unless the valves are in good condition the cylinders will not be properly lubricated. He has found that it is best gradually to close the throttle on superheater locomotives when coming to a stop. The maintenance of the superheater will be greatly

increased if the locomotive is not handled properly. On the Baltimore & Ohio each fuel supervisor is provided with a pyrometer which is applied to locomotives not performing properly as the occasion demands.

Other members spoke of the necessity for proper maintenance

of superheater locomotives if the full efficiency of the superheater is to be obtained. One member has found that the cooling of the fire in order to prevent popping reduces the degree of superheat sufficiently to affect materially the efficiency of the locomotive.

RAILROAD ADMINISTRATION NEWS

Director General McAdoo Resigns; Car Orders Held Up; Circulars from Washington and the Regions

WILLIAM GIBBS McADOO has resigned as director general of railroads, effective on January 1, 1919, or upon the appointment of his successor. He announced on November 22 his intention to retire to private life and, after a period of rest, to resume the practice of law in New York City.

Mr. McAdoo's reasons for the step, as given in his letter to the President, were that for almost six years he has worked incessantly under the pressure of great responsibilities, whose exactions have drawn heavily on his strength, and that the inadequate compensation allowed by law to cabinet officers and the very burdensome cost of living in Washington had so depleted his personal resources that he must, for the sake of his family, get back to private life to retrieve his personal fortune. He has received no compensation as director general of railroads and under the law could not be paid a salary for that office in addition to his salary as secretary, of \$12,000 a year, although he has fixed the salaries of members of his staff and of his federal managers at figures greatly in excess of his own and is paying his regional directors \$40,000 and \$50,000 a year.

Mr. McAdoo's announcement of his resignation was totally unexpected and even leading members of his railroad staff appear to have been kept in ignorance of the plan until after it had been given to the press. In spite of the strong reasons officially stated, a flood of speculation was aroused as to the possibility of other motives actuating the step and naturally many political considerations were advanced. The most common suggestion of this character was that Mr. McAdoo intends to become a candidate for President in 1920, and that he is now retiring, at the pinnacle of his success both in his handling of the country's finances and in his management of the railways under war conditions, before subjecting himself to any possibility of loss of prestige under the new conditions.

Naturally there has been much speculation as to whom the President will appoint as director general of railroads, particularly as it is considered that the appointment will give some indication as to whether the new man will be appointed for the purpose of preparing to restore the roads to their owners, or whether he will be expected to continue the process of unification. The names most frequently mentioned are Walker D. Hines, assistant director general, Charles A. Prouty, director of the Division of Public Service and Accounting, and Robert S. Lovett, director, Division of Capital Expenditures. There has been an idea prevalent that Mr. McAdoo would some day relinquish the direction of the railroads to his assistant, but there is also a strong feeling that the President would not appoint a railroad man to the office.

Pending the President's announcement there have been some signs of a cessation of activity on the part of the Railroad Administration as far as new plans for the future are concerned, which have led to some speculation as to whether or not they indicated a plan for an early settlement of the relations of the administration with the corporations. For

example, prospective orders for new equipment have been held up and activity in connection with changes in rates has been suspended, although only a week before Mr. McAdoo's announcement of his retirement the newspapers had been allowed to predict an active continuance of the work of completing the railroad unification.

EQUIPMENT ORDERS HELD UP

Some excitement was caused during the latter part of November on account of the request of the Railroad Administration to hold up work on the order for 600 additional standard locomotives which was reported in last month's issue. A few days later, however, instructions were issued to carry the work on these engines on to completion. The prospective orders for 2,000 hopper cars for the Virginian and for the 886 baggage cars for the Railroad Administration, however, have been held up, and it is understood that nothing will be done for the present regarding the expected orders for 375 passenger coaches and 129 combination passenger, baggage, mail and express cars, except that the work of completing the designs for the passenger cars will be taken up at next week's meeting of the Committee on Standard Appliances for Cars and Locomotives. Uncertainty as to what the future may develop as to the continuance of the Railroad Administration, the volume of traffic and the question of prices are also given as reasons.

SENIORITY RIGHTS OF EMPLOYEES IN MILITARY SERVICE

Director General McAdoo has issued general order No. 51 giving the following instructions regarding the seniority rights of employees who have entered the military service:

The majority of railroads under federal control have already made announcement with respect to the preservation of seniority rights for employees who have entered the military service of the Army and Navy, and have indicated that so far as practicable, preference in re-employment or reinstatement would be given to soldiers and sailors when mustered out of the service.

(1) In order that as nearly as practicable there shall be a uniform treatment of this matter, the following general principles will govern:

(a) In the case of an employee having established seniority rights, so far as practicable, and where the employee is physically qualified, he will be restored to such seniority rights.

(b) In the case of employees who do not have seniority rights under existing practices, a consistent effort will be made to provide employment for them when mustered out of military service.

(2) Upon railroads where the assurances given on this subject have been more specific than the provisions of paragraph 1 hereof, such assurances shall be observed.

DIRECTOR GENERAL PROHIBITS CHRISTMAS PRESENTS

Director General McAdoo has issued a circular, No. 64, directed against the practice formerly common, but which has been considerably reduced in recent years, of giving Christmas presents to railroad men. The circular says:

"A practice has grown up by which officers and employees of railroads have been given Christmas and other holiday presents by shippers, and by business houses who furnish supplies and materials to railroads.

"While in many instances these presents do not represent material value, yet the practice is essentially objectionable, and it is the policy of the Railroad Administration that it should be discontinued entirely."

DIRECTOR GENERAL TO SUPERVISE EMPLOYEES' MAGAZINES

Director General McAdoo's office has arranged a plan for exercising a general supervision over the various employees'

magazines published by many of the railroads, without interfering with the present management of each magazine. It has been arranged that they shall have a uniform date of issue and shall be distributed to the employees at the time they receive their pay checks. The director general's office will furnish them with a considerable amount of copy in the shape of orders, circulars and notices regarding the activities of the Railroad Administration and in addition some special articles by members of the organization. A newspaper man, Isaac Gregg, heretofore on the Washington staff of the New York World, has been added to the staff of the director general's office, to assist in preparing publicity matter including the material to be sent to the employees' magazines.

LOCOMOTIVES TO BE STORED AT STRATEGIC POINTS

In order to provide a reserve of power in the congested districts in the eastern section of the country the Railroad Administration has arranged to store 50 of the new standard locomotives at Potomac yards, just outside of Washington, D. C., and 110 in the vicinity of Cleveland, Ohio. It is the aim of the administration to hold these locomotives to clear up any blockades that may occur during the winter.

HENRY BARTLETT TO CONSIDER NEW DEVICES

Henry Bartlett, formerly chief mechanical engineer of the Boston & Maine and a member of the committee on standards for cars and locomotives of the mechanical department of the Railroad Administration, is to devote his attention especially to the examination and testing of new devices for the mechanical department in accordance with rules providing for the submission of new devices and inventions outlined in a circular issued by the division of operation in September.

LUBRICATION OF LOCOMOTIVES

Mechanical Department Circular No. 6 gives the following instructions regarding the lubrication of locomotives:

Investigation has developed that, in many instances, locomotives are not properly lubricated, which in addition to increasing coal consumption also causes excessive wear on cylinders, cylinder packing, valves and valve chambers, as well as on piston rod and valve stem packing.

It has been found that this is due on some roads to the practice of draining lubricators of all oil upon their arrival at the terminal and putting in the exact amount allowed for the trip before leaving. If excessive occur, or if the oil feed is not so regulated that it will last during the trip, the locomotive is often operated to the terminal with cylinders not lubricated. Cases are also found where on account of this practice yard engines are worked for hours without cylinder oil. This practice is extremely expensive.

Lubricators should be filled before locomotive leaves terminal, and sufficient oil should be carried on the locomotive to provide against any necessity for damaging cylinders, valves, packing or other parts of the machinery during the trip. Piston rod and valve stem packing should be properly lubricated, and a suitable swab provided to retain the oil.

Engine men will be held responsible for the proper use of all lubricating oils furnished them.

BAD-ORDER CAR SITUATION

As a continuation of the weekly statement of car condition reports published in the *Railway Mechanical Engineer* of November, page 614, the following three weeks' report is given, together with the percentage of bad order cars by regions, for four weeks ending October 12. It will be noticed that the percentage of bad order cars for all the roads under the jurisdiction of the Railroad Administration has been reduced to 5.8. For the week ending July 27 the percentage of bad order cars was 7.1. This shows a marked decrease and indicates an improvement which is particularly desired now.

CAR CONDITION REPORTS

	Sept. 28	Oct. 5	Oct. 12
Number of roads represented.....	137	140	139
Total revenue cars.....	2,484,491	2,492,862	2,448,437
Bad order cars.....	149,520	145,686	142,965
Heavy repairs.....	89,357	85,776	84,308
Light repairs.....	60,163	59,910	58,657
Percentage of bad order cars.....	6.0	5.8	5.8
Average bad order cars repaired per working day.....	97,863	94,840	92,583
Heavy repairs.....	10,737	10,203	9,922
Light repairs.....	87,126	84,637	82,661
Number of cars transferred to other shops.....	4,780	4,845	4,947
Number of employees.....	145,328	145,242	143,902

PERCENTAGE OF BAD ORDER CARS BY REGIONS

	Oct. 12	Oct. 5	Sept. 28	Sept. 21
Eastern.....	6.3	6.4	6.7	7.0
Allegheny.....	7.1	6.7	7.0	7.1
Poconantas.....	6.1	5.5	5.3	5.4
Southern.....	5.1	5.0	3.1	5.1
Central Western.....	5.3	5.3	5.2	5.2
Southwestern.....	3.2	3.1	3.1	3.2
Northwestern.....	5.8	6.3	6.5	6.6
All regions.....	5.8	5.8	6.0	6.2

SHOP EMPLOYEES' HOURS REDUCED

The emergency under which railroad employees in locomotive and car repair shops worked long hours during the war period having in some degree passed, Director General McAdoo, on November 22, issued directions under which the locomotive and car shop hours, as far as practicable, will be reduced to 9 hours per day, effective on November 25, and to 8 hours per day effective on December 9.

The director general sent the following telegram to all regional directors:

Last spring when the railroads were still struggling with congested traffic and weather conditions were very severe, the different mechanical organizations responded in a most gratifying way to the request that the men work a greater number of hours in the shops throughout the country than they had been accustomed to, or than some of their agreements with the railroads provided, in order to repair locomotives and cars for the prompt transportation of munitions of war and for food and other supplies for our army and navy abroad and the Allies. It is now possible, in view of the signing of the armistice, to anticipate an early return to normal conditions, and directions have been issued that wherever practicable the locomotive and car shop hours shall be reduced on November 25 to nine hours per day where greater number is now being worked and to basis of eight hours per day on December 9. The director general desires to express his deep appreciation of the patriotic response of the mechanical workmen on all railroads and his gratification that it is no longer necessary to call for number of hours of service heretofore required.

STANDARD LOCOMOTIVE DELIVERIES

The figures available the latter part of November indicate that a total of 514 of the United States Railroad Administration's order of 1,430 standard locomotives have been completed, consisting of 93 out of 570 from the Baldwin Locomotive Works, 409 out of 800 from the American Locomotive Company and 12 out of 60 from the Lima Locomotive Works. These figures do not include the recent order of 500 locomotives to the American Locomotive Company and 100 to Lima. Of the 514 standard locomotives built, 482 had been delivered to various roads under federal control up to and including November 23, as follows:

Atlanta & West Point.....	1	Eight-wheel Switcher
Atlantic Coast Line.....	5	Six-wheel Switchers
Baltimore & Ohio.....	37	Light Mikados
Central of New Jersey.....	10	Heavy Mikados
Central of New Jersey.....	7	Six-wheel Switchers
Chesapeake & Ohio.....	10	Heavy Mikados
Chicago & Alton.....	10	Light Mikados
Chicago & Eastern Illinois.....	15	Light Mikados
Chicago, Milwaukee & St. Paul.....	38	Heavy Mikados
Chicago Junction.....	14	Six-wheel Switchers
Cleveland, Cincinnati, Chic. & St. Louis.....	22	Light Mikados
El Paso & Southwestern.....	4	Heavy Mikados*
Erie.....	16	Eight-wheel Switchers
Erie.....	15	Heavy Mikados
Grand Trunk (Eastern).....	10	Light Mikados
Lake Erie & Western.....	15	Light Mikados
Lehigh & Hudson River.....	4	Light Mikados
Lehigh Valley.....	5	Light Mikados
Louisville & Nashville.....	20	Heavy Mikados
Michigan Central.....	20	Light Mikados
Nashville, Chattanooga & St. Louis.....	4	Light Mikados
New York Central.....	24	Eight-wheel Switchers
New York Central.....	7	Light Mikados
New York, Chicago & St. Louis.....	10	Light Mikados
Pittsburgh & West Virginia.....	3	Light Mikados
Pennsylvania Lines West.....	5	Six-wheel Switchers
Pittsburgh, McKeesport & Youngiobgheny.....	10	Light Mikados
Rutland.....	6	Light Mikados
Rutland.....	1	Light-wheel Switcher
Seaboard Air Line.....	10	Light Mikados
Southern.....	25	Light Mikados
Southern.....	3	Eight-wheel Switchers
Texas & Pacific.....	11	Light Mikados
Toledo & Ohio Central.....	5	Eight-wheel Switchers
Toledo & Ohio Central.....	15	Light Mikados
Union Pacific.....	20	Light Mikados
Wabash.....	1	Light Mikados
Western & Atlantic.....	1	Eight-wheel Switcher
Wheeling & Lake Erie.....	20	Heavy Mikados
Wheeling & Lake Erie.....	4	Eight-wheel Switchers

*Ten U.S.R.A. Mikado locomotives constructed for the Wabash and three U.S.R.A. Mikado locomotives constructed for the El Paso & Southwestern were sent to Cleveland to be stored as part of an emergency pool.

STANDARD CAR DELIVERIES

Of the 100,000 standard freight cars ordered by the Rail-

road Administration in April, 4,588 had been delivered up to November 14. The cars were delivered by the various car building companies as follows: American Car & Foundry Company, 1,595; Haskell & Barker Car Company, 594; Pressed Steel Car Company, 1,112; Pullman Company, 146; Ralston Steel Car Company, 191, and Standard Steel Car Company, 950. The Railroad Administration is now giving out a weekly statement of the car deliveries similar to its statement of locomotive deliveries. The combined statements for the three weeks ending November 16 show the following deliveries, amounting to 2,708:

Road	Number	Type	Manufacturer
A. C. L.	146	50-T. Comp. Gond.	Haskell & Barker
B. & L. E.	15	55-T. S. Hopper.	A. C. & F. Co.
C. & N. W.	338	40-T. D. S. Box.	A. C. & F. Co.
C. & N. W.	277	50-T. Comp. Gond.	A. C. & F. Co.
C. & N. W.	70	50-T. Comp. Gond.	Haskell & Barker
C. C. & O.	73	50-T. S. Hopper.	Press. Steel C. Co.
C. C. & O.	76	55-T. S. Hopper.	Std. Steel Car Co.
C. C. & St. L.	98	55-T. S. Hopper.	A. C. & F. Co.
C. C. & St. L.	181	55-T. S. Hopper.	Press. Steel C. Co.
C. C. & St. L.	186	55-T. S. Hopper.	Pullman Co.
C. C. & St. L.	200	55-T. S. Hopper.	Ralston Co.
C. C. & St. L.	200	55-T. S. Hopper.	Std. Steel Car Co.
C. O. & O.	177	50-T. S. Hopper.	Press. Steel C. Co.
M. & Y. C.	35	50-T. Comp. Gond.	A. C. & F. Co.
M. & Y. C.	198	50-T. Comp. Gond.	Press. Steel C. Co.
M. & Y. C.	338	55-T. S. Hopper.	Std. Steel Car Co.
N. Y. C.	81	55-T. S. Hopper.	Press. Steel C. Co.
P. & L. E.	49	50-T. S. Hopper.	Press. Steel C. Co.
Total	2,708		

ORDERS OF THE REGIONAL DIRECTORS

Plan of Organization of Purchasing and Stores Department.—Order 108 of the Southwestern regional director and Circular 195 of Central Western regional director outline a plan for the organization for the purchasing and stores departments as agreed to by the director of the Division of

in actual use and of the storehouses and other places where material is stored.

4. He shall be aided by and shall appoint a general storekeeper and other necessary assistants such as fuel agents, stationers, tie and timber agents and commissary agents, who shall report to the purchasing agent direct.

5. An exception as to paragraphs 3 and 4 may be made, with approval of the regional director, upon railroads where the stores department is separately organized, and now reporting direct to the federal manager.

6. All storekeepers and all others, more than half of whose time is devoted to the handling or accounting for material, shall be appointed by and be under the charge of the general storekeeper and on his payroll.

7. All appointments of purchasing agents, general storekeepers, fuel agents, tie and timber agents, shall be subject to the approval of the regional directors.

8. The regional purchasing committee with the approval of the regional director shall appoint a supervisor of stores to have general supervision over the stores department and reporting direct to the regional purchasing committee.

Working Hours of Locomotive and Car Repair Forces.—

In order 106 and a circular dated October 26, the Southwestern and Central Western regional directors respectively announce a working schedule for employees in locomotive and car departments during the coming winter:

The hours for men in the locomotive department should be not less than 58 per week divided as follows: Five days of 10 hr. each, 8 hr. on Saturday. If Sunday work is found necessary, 8 hr. every second Sunday should be worked.

Such overtime as may be necessary to balance shop work for the complete repairs to a locomotive that is being turned out will, of course, be worked as usual in addition to the above hours.

Beginning November 15, the hours for car department employees should be not less than 53 per week, divided as follows: Five days of 9 hr., 8 hr. on Saturday. If Sunday work is found necessary, 8 hr. every second Sunday should be worked.

On roads which can maintain the percentage of bad order cars below four, 2 hr. per day may be worked.

A reduction in the hours of the car department forces is made because work must be done chiefly in daylight hours.

Repairs to Locomotives.—The Southwestern regional di-

AUTHORIZATIONS AND EXPENDITURES IN CONNECTION WITH WORK CHARGEABLE TO CAPITAL ACCOUNT AS OF NOVEMBER 10, 1918—CLASS I RAILROADS

Class of work (1)	1918 budget (2)	Additions to budget (3)	Work specifically authorized on D. C. E. forms 1, 2, 3 and 4, to November 10, 1918 Chargeable to—		Expenditures from January 1, 1918, to September 30, 1918 Charged to—		Unexpended balance Chargeable to—	
			Operating expenses (4)	Capital account (5)	Operating expenses (6)	Capital account (7)	Operating expenses (8)	Capital account (9)
ADDITIONS AND BETTERMENTS (Excluding equipment)								
Fuel stations and appurtenances	\$6,090,558	\$1,650,249	\$1,109,456	\$7,756,523	\$320,188	\$2,590,363	\$789,268	\$5,166,300
Water stations and appurtenances	13,430,047	1,706,624	1,907,836	10,767,265	573,852	4,281,751	1,333,984	6,390,944
Shop buildings, enginehouses and appurtenances	62,694,927	9,256,573	6,465,459	52,772,474	1,730,632	15,698,759	4,734,827	37,073,715
Shop machinery and tools	9,142,488	4,636,668	1,325,637	20,173,327	307,501	5,467,487	1,018,136	14,704,840
EQUIPMENT								
Locomotives, steam	\$196,926,868			\$116,650,975		\$51,183,399		\$65,467,576
Locomotives, steam, ordered by R. R. Administration				76,873,355		*23,857,762		\$53,015,593
Locomotives, other				2,359,213		1,684,933		674,281
Freight-train cars	212,858,464			94,716,146		66,404,773		28,311,373
Freight-train cars, ordered by R. R. Administration				289,466,006		*44,490,812		244,969,188
Passenger-train cars	28,459,830	\$155,337		12,417,401		8,836,325		3,581,076
Work equipment	6,538,810	1,771,745		7,016,124		1,537,826		5,478,598
Motor car and trailers	557,039			20,200		538,547		529,011
Floating equipment	5,323,337	412,342		5,129,889		632,823		4,497,366
Miscellaneous equipment	507,223	84,724		603,677		221,932		381,745
Improvements to existing equipment	35,807,654	4,135,765	\$19,276,960	40,421,567	\$5,213,654	17,277,675	\$14,063,306	23,143,892
Total equipment	\$486,979,925	\$6,580,113	\$19,276,960	\$646,235,905	\$5,213,654	\$216,156,206	\$14,063,306	\$430,049,699
Construction of extensions, branches and other lines								
	\$20,320,489	\$2,066,072	\$23,836	\$39,063,037	Cr. \$6,576	\$13,961,847	\$30,412	\$25,101,190
Total, all work	\$941,041,902	\$61,471,942	\$140,400,589	\$1,175,848,883	\$35,483,125	\$403,864,950	\$104,917,464	\$771,983,933

*Expenditures to date.

Finance and Purchases and the director of the Division of Operation of the Railroad Administration:

1. The purchasing department shall be in charge of a general purchasing agent or purchasing agent reporting direct to the federal manager, or general manager where there is no federal manager in charge.

2. The purchasing agent, in co-operation with the regional purchasing committee shall buy all material and supplies, including fuel, dining car and restaurant supplies, and sell all scrap and obsolete material, including equipment. He shall also have direct charge of the handling of scrap and the reclaiming of usable material.

3. He shall be responsible not only for the purchases and sales, but for the quantity of material on hand, the custody, care and distribution thereof, and charges therefor, and necessarily shall have charge of all material not

recovered by the practice of railroads repairing locomotives at their home shops, which prevailed during corporate control, will be continued as far as practicable. When the facilities are insufficient and it is desired to move engines for repairs to shops on another line under the same federal manager's jurisdiction or shops under authority of another federal manager, the approval of the regional director must be previously obtained.

Air Compressors for Locomotives.—The Southwestern regional director, in Circular 125, suggests the advisability of

changing to 8½-in. cross compound pumps on heavy power when locomotives receive class 1, 2 or 3 repairs, if the cross compound pumps can be obtained. An 8½-in. cross compound air compressor will produce approximately three times as much air as will a 9½-in. simple air compressor, approximately twice as much air as an 11-in. simple air compressor, while the number of pounds of steam used per 100 cu. ft. of air is approximately one-third as much in a cross compound pump as in the simple types. The use of the compound compressor will therefore be in the interest of the maximum

supply of compressed air as well as in the interest of fuel economy.

Age of Locomotives.—The Eastern regional director in Order 5001-1-A246 asks for a list of locomotives over 25 years old which are not good for efficient service. Also a list of locomotives over 20 years and less than 25 years old, the type or condition of which is such that they are not contributing to the efficiency of operation. Locomotives in either list which have been heretofore reported to the Regional Purchasing Committee for sale should be marked with an X.

RADIANT HEAT AND FIREBOX DESIGN*

Combustion Chambers Increase Furnace Efficiency and Radiation; Long Tubes Are of Little Value

BY J. T. ANTHONY
Vice-President, American Arch Company

FOR some unknown reason, most gases will neither radiate heat nor be heated up by heat rays from some other source. In order to heat a gas it is necessary to bring its molecules into actual contact with a hot body, and in order to cool a gas it is necessary to bring its particles into actual contact with a cooler body.

Burning gas, or flame, both absorbs and emits heat rays; but the instant the flame burns out and the gases become transparent, radiation ceases. This property of gases has an important bearing on firebox design.

A perfectly "black body" is one that absorbs all heat and light waves falling upon it and reflects none. In a locomotive firebox we approach very close to the ideal black body, in that practically all the heat radiated from the glowing fuel bed and flames is absorbed by the surrounding soot-covered surfaces. The amount of heat so absorbed depends upon two things: first, the area of the radiating surfaces; second, the temperature. If we increase the firebox heating surface without increasing the area of the heat radiating surfaces or their temperature, there will be practically no increase in the amount of heat radiated.

If we were using a coke or a hard coal that burns without any flame, the total amount of radiating surface would be equal to the grate area and increasing the firebox heating surface would have but little effect on the firebox evaporation. When using a high volatile coal, however, the heat radiated from the fuel bed can be disregarded, for in this case the temperature and extent of the flames becomes the controlling factor. The flames being interposed between the heating surfaces and the fuel bed, absorb the heat radiated from the fuel bed in addition to the heat being generated within the flames by the burning combustibles, and radiate this heat to the surrounding heating surfaces. It is then apparent that increasing the volume of the firebox and filling the added volume with flame results in increasing the radiating surface and the amount of heat radiated.

The installation of a combustion chamber results in an increase of both volume and heating surface, but the added heating surface is of little value if the firebox volume is not utilized and filled, or partly filled, with flame. The amount of flame in a firebox depends primarily upon the amount of combustible gas being driven off, the air supply, and the volume of the firebox.

With a fair grade of bituminous coal and ordinary firing methods, fully 50 per cent of the heat generated in the firebox is due to the burning of combustible gases above the

fuel bed. In order to burn this completely it is necessary to have an excess of oxygen above the fuel bed, to mix this oxygen intimately with the combustible gases and to provide sufficient flamework or combustion chamber space. It has proved very difficult, if not impossible, to get sufficient oxygen above the fuel bed at moderate or high rates of firing, and to mix thoroughly the oxygen with the combustible gases. The brick arch has proved to be a very effective gas mixer, but the lack of air or oxygen can only be offset, or partly offset, by increasing the firebox volume by adding a combustion chamber and thereby increasing the time available for the completion of combustion.

The effect of temperature upon the amount of heat radiated is shown in Fig. 1. The points determining the curve

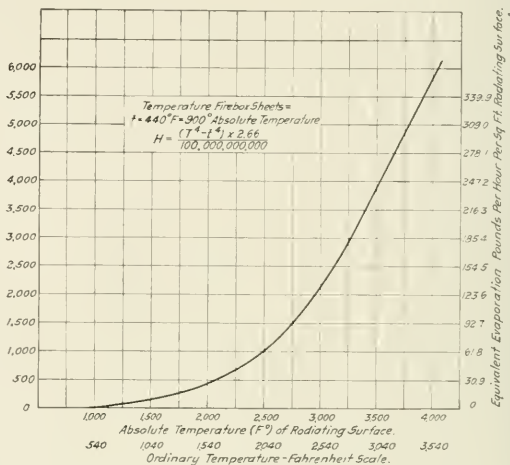

Fig. 1—Relation of Radiation and Evaporation to Firebox Temperature

have been calculated from the Stefan-Boltzmann formula, which is shown in the diagram. As shown by the curve, a little increase in temperature means a big increase in firebox evaporation.

If we know the average firebox temperature and the area of the radiating surfaces, we can approximate with a fair

*From a paper read before Central Railway Club, May 10, 1918.

degree of accuracy the total amount of heat radiated to the firebox surfaces and the amount of water evaporated by the firebox surfaces; or if we know the temperature of the gases entering the tubes and the temperature of the gases at the front end and the analyses of the gases, we can, after establishing a heat balance, calculate with a fair degree of accuracy the total evaporation from the tubes. This amount, subtracted from the total boiler evaporation, will give us the firebox evaporation.

The latter method has been used in analyzing test data from a Pacific locomotive in order to determine approximately the relative value of firebox and tube heating surfaces. The locomotive in question had a grate area of 70

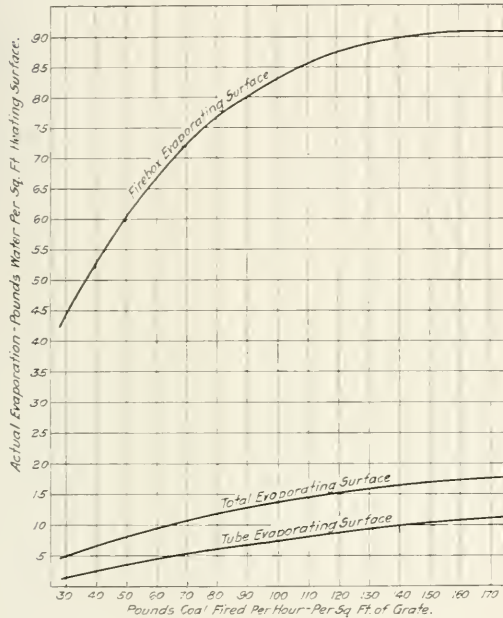

Fig. 2—A Comparison of the Rate of Actual Evaporation for Firebox and Tube Heating Surfaces in Relation to Rate of Combustion

sq. ft., barrel combustion chamber 36 in. long, tubes 19 ft. long and 2½ in. in diameter, total firebox and combustion chamber heating surface 307 sq. ft., and total tube heating surface 4,557 sq. ft.

Using a formula proposed by Professors Fessenden and Haney as the result of tests on heat transmission through boiler tubes, conducted at the University of Missouri, the tube evaporation was calculated for the varying rates of combustion and these subtracted from the total evaporation to get the firebox evaporation. The results in pounds of water evaporated per sq. ft. of heating surface are shown by the curves in Fig. 2, where it will be noted that the evaporation per sq. ft. of tube heating surface varied from 1½ to 11 lbs. per hour, while the actual evaporation per sq. ft. of firebox heating surface varied from 42 to 91 lb. per sq. ft. of heating surface per hour, as the rate of combustion increased from 30 to 170 lb. of coal per sq. ft. of grate. On a basis of equivalent evaporation, the firebox absorbed from 66 per cent of the total heat at the low rates to 39 per cent at the highest rate.

The coal as fired averaged about 14,300 B.t.u., firebox temperatures ranged from 2,150 to 2,570 deg. F.; total gas per pound of coal fired varied from 14 lb. to 8 lb.

When burning 160 lb. coal per sq. ft. of grate per hour, or a total of 11,200 lb. of coal per hour, the firebox had an equivalent evaporation of 33,400 lb., while the tubes evaporated 50,800 lb., the total evaporation from the boiler being 84,200 lb. per hour. Assuming that the firebox was completely filled with flame, the flame radiating surfaces equal the firebox heating surfaces, and the equivalent evaporation per hour per sq. ft. of firebox heating surface was about 109 lb. At this rate each sq. ft. of firebox heating surface absorbed 105,730 heat units per hour; and since the effective flame-radiating surface equals the firebox heating surface, each sq. ft. of radiating surface was radiating at the rate of 105,730 heat units per hour, or 1,762 heat units per minute.

In order to radiate this much heat, an average temperature of 2,400 deg. F. was required; during the test in question the pyrometer located at the end of the arch indicated a temperature of about 2,550 deg. As this temperature reading was taken at the point where the gas area was restricted, the mixing effect most effective and the combustion very violent, the temperature would naturally be higher. A difference of 150 deg. between the temperature at this point and the average temperature of the firebox as calculated is not unreasonable.

By means of the Fessenden formula mentioned, the temperature drop of the gases passing through the tubes was calculated and from this the evaporation for each one-foot section of the tubes, using Holborn and Henning's values for the specific heat of the different gases at the varying

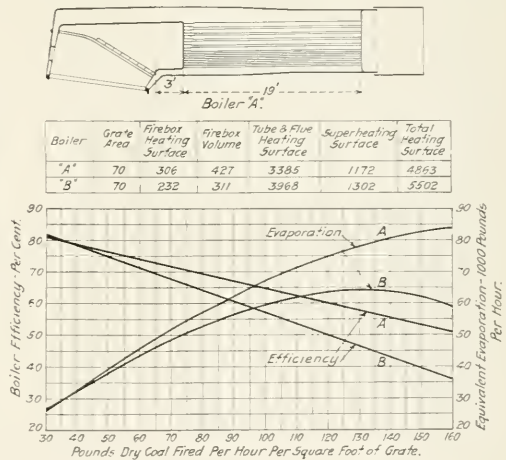

Fig. 3—Comparison of Performance of Similar Boilers With and Without Combustion Chambers

temperatures. The resulting evaporations per one-foot section of tubes run from 8.120 lb. per hour from the first one-foot section to 620 lb. per hour in the last one-foot section; giving an equivalent evaporation per sq. ft. of tube heating surface of from 34 lb. per hour in section adjacent to firebox to 2½ lb. per hour in the section next to the front end.

The firebox was responsible for 39.7 per cent of the total evaporation, the first section of tubes evaporated 9.6 per

cent; the next section 8 per cent, and so on, gradually decreasing to the last, or nineteenth section, which evaporated only seven-tenths of one per cent of the total. The firebox and first 10 ft. of tubes evaporated 89.1 per cent of the total; the firebox and first 15 ft. of tubes evaporated 96.6 per cent of the total; while the last four one-foot sections adjacent to the front end accounted for only 3.4 per cent of the total,—and this with 19-ft., 2¼-in. tubes. These figures indicate the relative value of the different heating surface locations and show conclusively the value of combustion chamber and firebox heating surface exposed to the action of radiant heat, as compared to heating surface gained by the use of long tubes.

So far, no attempts have been made to establish a definite relation between combustion chamber length and tube lengths, or between the length of firebox from door sheet to tube sheet and length of tubes. These proportions of course should vary with the nature of the fuel used. When using bituminous coal, which constitutes the major portion of our locomotive fuel, the indications are that the firebox from door sheet to tube sheet should be approximately as long as the tubes. In some cases it could no doubt be made longer to advantage. This statement is based not solely upon the value of the different heating surfaces as shown, but also upon the fact that locomotive boiler efficiency is governed primarily by the furnace efficiency; and high furnace efficiency cannot be obtained without ample firebox volume. There is no logical reason for applying long tubes and providing large areas of heating surface before adequate provision has been made for a furnace that will burn the coal and liberate all the heat contained.

Tests conducted both in this country and abroad show clearly that nothing is to be gained by increasing the tube lengths beyond 18 ft. or 19 ft. Tests have likewise shown the advantage of combustion chambers in increasing boiler capacity and efficiency.

Fig. 3 shows the relative capacity and efficiency of the combustion chamber boiler mentioned above as compared with a similar boiler without a combustion chamber and with tubes 22 ft. long. At a rate of combustion of 40 lb. of coal per sq. ft. of grate per hour the efficiencies and capacities of the two boilers were the same; but as the rate increased the combustion chamber boiler showed a marked superiority. As shown by the evaporation curves, the boiler *B* without a combustion chamber reached its maximum capacity at a rate of combustion of 135 lb. of coal per sq. ft. of grate; while the combustion chamber boiler continued to increase in capacity even at a rate of 160 lb. This indicates that the firebox of boiler *B* could not be forced beyond a rate of 135 lb.; and even at that rate its furnace efficiency was only 62 per cent while that of the combustion chamber boiler was 74 per cent. This difference may not have been due entirely to the combustion chamber but it was due entirely to an improvement in combustion conditions which resulted in higher temperatures and increase in radiating surfaces.

The main objection urged against combustion chambers, aside from some structural details, is that they tend to reduce the temperature of the gases entering the tubes. If such a drop in temperature does occur, it not only means that the front end temperatures will be lower and the boiler efficiency will be higher, but it also shows that the combustion chamber space is being utilized for the burning of the gases.

The heat given off by the actual contact of the gases with firebox heating surface is insignificant when compared to the heat that is radiated from the flames. For instance, at a rate of combustion of 120 lb. gases entering the 36-in. barrel combustion chamber at a temperature of 2,320 deg. F. would be reduced to 2,295 deg., or a 25-degree drop in

temperature, due to the contact of the hot gases with the heating surfaces. If the combustion chamber were 8 ft. long, the drop due to the same cause would be only 68 deg., so it is evident that if we have a very large drop in temperature, it is due to the heat being radiated from the flames, for transparent gases do not radiate heat. Under the same conditions and with gases entering the tubes at a temperature of 2,295 deg., there would be a drop of 600 deg. in passing through the first three-foot length of tubes and a drop of 1,200 deg. in passing through the first eight feet.

It is evident, then, that the combustion chamber heating surfaces are not arranged to take up any great amount of heat from the gases by convection or actual contact with the gases. Such heating surfaces depend almost entirely upon heat radiated from the burning gases. The instant the gases cease to burn the flame disappears, radiation ceases and there is little further drop in temperature regardless of the length of combustion chamber.

There is no logical objection to the use of long combustion chambers when burning a highly volatile fuel, and many reasons why they should be used. The results of investigations made for the Bureau of Mines by Henry Kreisinger and his associates, described in Bulletin 135, relative to the combustion of gases in stationary furnaces equipped with long combustion chambers, indicate that under the conditions that generally prevail in the locomotive firebox there is little danger of getting too much firebox volume or combustion chamber space.

Boiler heating surfaces are highly efficient compared to the furnace. There are thousands of locomotives in service to-day equipped with boilers of sufficient heating surface to generate a great deal more power than they are at present doing if they could be equipped with fireboxes of sufficient grate area and volume to insure a higher furnace capacity.

FOURTH LIBERTY LOAN RESULTS

The final reports to Director General McAdoo show that the railroad men of the United States subscribed for a total of \$184,868,300 in Fourth Liberty Loan bonds. This compares with \$106,655,450 subscribed in the third loan, an increase of \$78,121,850.

A tabulation of subscriptions by regions shows that the honors for the campaign belong to the Southwestern region, 99.1 per cent of the 170,333 employees of that region having subscribed for a total of \$21,487,650, an average of \$126 per subscriber. The Eastern region, the largest of the seven, naturally led in the total subscribed with \$54,697,200, but its percentage of employees subscribing and the average subscription were not as high as in the Southwestern region.

The totals in detail follow:

Region	Number subscribers	Percentage employees	Amount subscriptions	Amount per subscriber
Administration Headquarters	1,014	100.	\$502,000	\$495.10
Eastern (Wash.)	532,173	96.	54,697,200	102.00
Southwestern	170,333	99.1	21,487,650	126.00
Central Western	307,546	76.69	36,082,850	120.58
Pacohantas	48,954	87.23	4,380,550	89.48
Southern	184,035	78.	16,253,200	88.00
Allegheny	291,985	94.86	23,611,100	80.86
Northwestern	248,165	97.92	27,853,750	112.24

Throughout the country the employees of the mechanical department made a splendid showing. In the Eastern region they contributed \$17,604,850, or about one-third of the total, 97 per cent of the men in that department subscribing. In the Northwestern region 99.33 per cent of the mechanical department employees subscribed. Perhaps the best record made was on the St. Louis roads, where every one of the 40,889 employees under Federal Manager A. Robertson subscribed, the total amount being \$6,665,500, or \$163 per employee. The mechanical department employees subscribed more heavily than any other class of employees on these lines.

GAR DEPARTMENT

ADAPTING BAKER HEATERS TO BURN SOFT COAL

BY A. KRESSIN

Steamfitter Foreman, Chicago, Milwaukee & St. Paul

The question of using soft coal for heating passenger cars equipped with Baker heaters is important at the present time on account of the shortage of hard coal. These heaters are all designed for anthracite coal and if bituminous coal is burned in them as they stand, the smoke and gases will escape into the car. The high price of hard coal and the difficulty of obtaining it at this time led the Chicago, Milwaukee & St. Paul to investigate the possibility

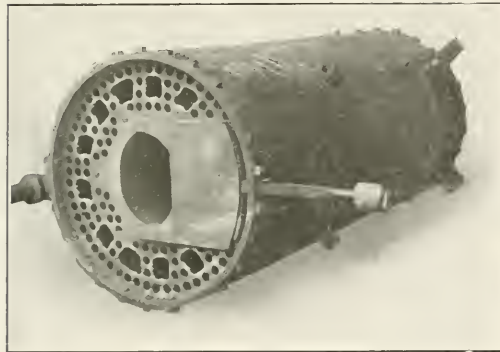

Fig. 1—Heater Drum Showing Holes Cut at the Top to Increase the Draft

of making alterations in the Baker heaters that would adapt them for burning soft coal. With this end in view extensive tests were conducted at the Milwaukee shops. A car was set out on one of the shop tracks and boarded up to prevent a change of air due to drafts around the windows.

The investigation served to show that soft coal required more draft than could be secured with the ordinary arrangement. After making numerous trials an arrangement that would burn soft coal successfully was found. The size of the stove pipe was increased from 5 in. to 7 in. diameter and it was made as nearly straight as possible. An 8½-in. pipe with 1-in. holes around the bottom was placed over the 7-in. pipe where it passed through the roof of the car, as shown in the drawing, forming a ¾-in. dead air space around the pipe. In order to improve the draft, larger holes were cut in the concave plate in the top of the heater, thus allowing the smoke to escape more readily and preventing it from entering the car proper when the upper door in the heater is open. These changes are plainly shown in the photograph.

In the old style heaters a sheet iron smoke screen was installed operating on the same principle as the screen in the fireproof heater. Large holes were also cut in the cast iron

top between the smoke flues and the smoke screen, to improve the draft, as shown in the drawing.

In order to allow the heated air and gas to escape from the heater rooms, a 10-in. ventilator was placed in the roof with a pipe leading through the roof and the ceiling. A sheet iron plate with a number of ½-in. holes punched in it was set in the door of the heater room to give more air. The size of this plate was varied to suit the construction of the door.

When using soft coal in Baker heaters, care must be taken to prevent over-heating on account of the free burning character of soft coal as compared with hard coal. The coal must not be allowed to arch over in the firebox but should be kept down on the grates at all times. A large poker should be kept inside the heater room for this purpose. If these precautions are closely followed, soft coal can be burned without danger of fire. Several tests have been conducted to determine how long the fire could be held in these heaters with soft coal. One or two buckets of coal were first put in and after sufficient time had elapsed to allow the fire to be-

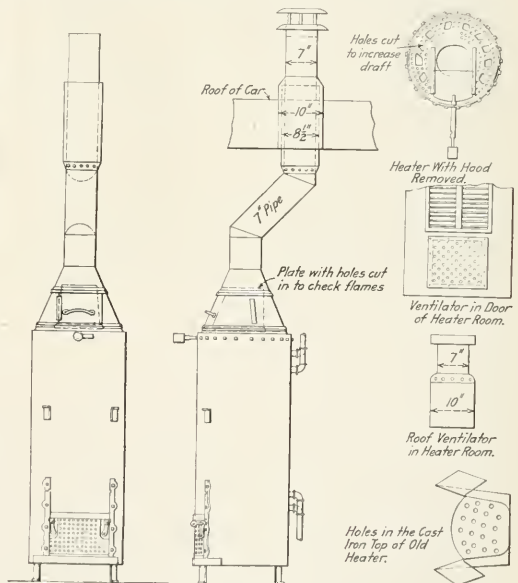

Fig. 2—Changes Made in Baker Heaters to Burn Soft Coal

come well established, the heater was filled to the top with coal and the fire was checked by closing the lower and opening the upper door. In this way the fire has been maintained for five days and nights without putting in additional coal. No gas or smoke was found in the car. By following the methods described above, soft coal can be burned without

danger from fire, thus eliminating the trouble of carrying a stock of hard coal to supply passenger cars and resulting in a considerable saving. The Baker heaters on the Chicago, Milwaukee & St. Paul are being changed as fast as possible to burn soft coal.

PISTON TRAVEL AND BRAKING POWER*

BY H. F. WOOD

Supervisor Air Brakes, Boston and Maine

In brake operation the piston travel is of such importance that the unequal condition in which it is found varies every operation of the brakes in so far as power is concerned. This is not alone all that it does. It varies the time required to obtain the braking power expected to be had from a given brake pipe reduction, or we can go still further and say that it is possible to get several times the braking power on one car as compared to another, due wholly to the variation in piston travel. With these conditions, which we must allow exist, all can see what it means to brake manipulation as far as producing shocks is concerned, and it is a condition over which the engineer does not have full control. We can go still further in this direction and add that it is these varying conditions that produce excessive braking power on some cars and little or none on others, both of which produce shocks due to the surging of the train, and flat wheels, due to cars being pulled or bumped off their "feet," as well as damage to the lading.

In order to show what difference the different lengths of piston travel make in brake cylinder pressures and braking power on loaded and empty cars, providing no brake cylinder leakage was present, the following tables are given. They will explain in a simple way, the causes of trains bunching or stretching when the brakes are applied.

TABLE NO. 1

Train Pipe Reduction (Lb.)	Piston Travel (In.)	Cylinder Pressure	Cylinder Value	Percentage of Braking Power Empty Car	Percentage of Braking Power Loaded Car
10	4	52.5	2,650	63	17.06
10	5	41	2,050	49.2	13.06
10	6	33	1,650	39.6	11.
10	7	27.5	1,375	33.	9.16
10	8	23	1,150	27.6	7.6
10	9	19	950	22.8	6.33
10	10	16	800	19.2	5.3
10	11	13	650	15.6	4.3

TABLE NO. 2

Brake pipe reductions necessary to produce equalization of pressures with piston travel varying from 4 inches to 11 inches.

Piston Travel (In.)	Equalization of Pressures (Lb.)	Brake Pipe Reduction (Lb.)
4	59	11
5	57	13
6	55	15
7	53.5	16.5
8	51.5	18.5
9	50	20
10	49	21.5
11	47	23

Similar tables to these could be made for any other brake pipe reductions. As a result it can be readily seen that if in a train some brake cylinders have long piston travel and some short, a very uneven braking power will be developed for any and all brake pipe reductions.

Let us see what effect this unequal distribution of braking power has. Suppose that two cars are coupled together, each having a light weight of 35,000 lb., with the standard 8-inch equipment, the first car having 11 inches piston travel and the second car 4 inches. If a full service application is necessary to stop the two cars, a brake pipe reduction of a sufficient amount must be made to equalize the brake cylinder and auxiliary reservoir pressures of both equipments, which will be 23 lb., although 11 lb. would be sufficient for the second car. Therefore, 12 lb. of brake pipe air is wasted

from the second car. However, the second car obtained a cylinder pressure of 59 lb. while the head car only obtained a cylinder pressure of 47 lb.

Let us suppose now that these two cars be arranged to furnish 60 per cent braking power with 50 lb. cylinder pressure; 59 lb. in the cylinder of the second car represents 70.8 per cent while 47 lb. in the head cylinder represents 56.4 per cent, and 70.8 per cent braking power on the second car equals 24,780 lb.; 56.4 per cent braking power on the first car equals 19,740 lb. As a result, the stopping power on the second car is 5,040 lb. greater than on the head car and a draw bar pull of this amount is present throughout the stop.

Let us look at this situation from another point of view. Suppose that a 10-lb. service reduction was made. This would produce a cylinder pressure of 52.5 lb. in the second car and a cylinder pressure of 13 lb. in the first car. The percentage of braking power on the second car would equal 63 per cent or 22,050 lb., while the percentage of braking power on the head car would only equal 15.6 per cent or 5,460 lb. In this case a draw bar pull between the two cars during the application would equal 16,590 lb. or nearly three times more braking power on the second car than on the first one.

It is evident from this that a uniform piston travel is most desirable. If it is long, the brake cylinder pressure is thereby reduced and the efficiency low; further, a greater quantity of air is consumed in brake applications than would otherwise be necessary, entailing greater demands upon the air compressor. If the piston travel is too short, it is liable to cause the brake shoes to drag upon the wheels when brakes are released, and by too high a cylinder pressure, with the possibility of wheel sliding and rough stops when brakes are applied.

Now consider for a moment what the results are from the difference in the cylinder pressures and the time in which it is obtained with the varying piston travels, and at the same time think over the difference in the braking power on the empty and loaded cars.

I believe then, that you will allow first, that the only salvation against shocks and break-in-tuos is either to let the train drift to a stop or keep the train bunched or stretched when making stop and by all means make the initial brake pipe reduction light in order that only a low braking power be developed until the slack has adjusted itself, and under no circumstances release the brakes unless the slack and speed conditions permit, until stop is made.

It is the practice of many railroads to haul the loads ahead and the empties behind. This is in my opinion better than handling them in the reverse order, for in case of trouble with the empties behind the result is generally a parting of the train, while with loads behind the result is the opposite and the buckling of the train takes place.

In order to avoid the great difference in braking power on account of the variation in weight of train at any section, it would be better to alternate them, thereby avoiding the great difference in braking power. A better method however, is to handle loads and empties in different trains. This creates switching and will no doubt be considered out of the question. Nevertheless, we have got to look at and work to better the situation. The proposition is before us and it reduces itself to the following: First, switching; second, inspection; third, maintenance, and fourth, instructions.

Break-in-tuos are caused by greater braking power at the rear than at the forward part of the train, and is a separation and not a collision. The damage generally is not great. The sudden bunching or buckling of the train is caused by greater braking power at the head end. This may be responsible for a bad accident, not only on the train on which it occurs but to others in the opposite direction, on double track roads.

*From a paper presented before the New England Railroad Club.

STANDARD U. S. R. A. REFRIGERATOR

Latest Practices Followed in Design; Ice Baskets, Solid Insulated Bulkhead and Steel Underframe

THE mechanical department of the United States Railroad Administration has recently issued Mechanical Department Circular No. 7, covering repairs to freight cars, which is based on the designs for a standard refrigerator car made by the Railroad Administration. The circular states: "In order to insure the greatest possible degree of efficiency in refrigeration and conservation of foodstuffs, refrigerator cars having trucks of 60,000 lb. capacity or over will, when receiving general repairs or being rebuilt, be made to conform to the United States standard refrigerator car requirements." The circular requires that the general arrangement of the cars be as near as practicable to that shown on drawing No. 1386. The ice boxes to be in accordance with drawing No. 1389, the hatch arrangement in accordance with No. 1390 and the floor and walls in accord-

- | | |
|---|--|
| Hatch hinge pin (Dr. 1731) | Side door hinge (Dr. 1623) |
| Well trap cone (Dr. 1610) | Locking rod guide (Dr. 1635) |
| Door locking rod (Dr. 1639) | Side door lock arm (Dr. 1659) |
| Locking rod back plate (Dr. 1649) | Seal hook and chain (Dr. 1664) |
| Side door locking rod socket (Dr. 1654) | Door open fastener (Dr. 1675) |
| Side door locking rod socket (Dr. 1655) | Clip for door open fastener (Dr. 1676) |
| Side door step (Dr. 1656) | Link for door open fastener (Dr. 1677) |
| Side door seal pin keeper (Dr. 1657) | Door hinge pin (Dr. 1730) |
| Side door seal pin (Dr. 1658) | |

The railroads are requested to send to the Mechanical Department, Division of Operation, at Washington, blueprints of the cars that do not meet the specifications, with the following information:

- Number of cars owned that will need to be changed to meet the requirements.
- Estimated cost of making the changes.
- Location of shops where cars will receive such changes.

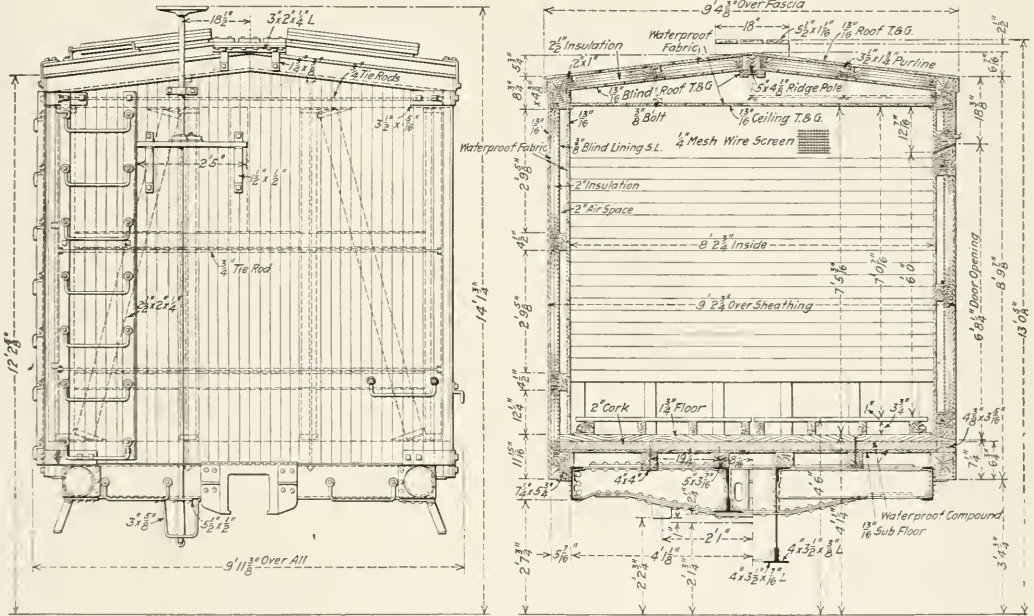

End Elevation and Section of U. S. R. A. Standard Refrigerator Car (Drawing No. 1386)

ance with drawing No. 1387, all of which are shown in connection with this article. Other details of these cars have been prepared and may be obtained from Frank McManamy, assistant director, Division of Operation, in Washington. These cover:

- | | |
|---|-----------------------------------|
| Hatch plug hinge (Dr. 1606) | Well trap (Dr. 1616) |
| Hatch plug hinge strap (Dr. 1607) | Well trap cover (Dr. 1617) |
| Hatch plug lifter guide (Dr. 1608) | Drain pipe (Dr. 1604) |
| Hatch cover hinge (Dr. 1609) | Floor racks (Dr. 1644) |
| Hatch cover lever (Dr. 1611) | Floor rack hinge plate (Dr. 1724) |
| Hatch plug lifter (Dr. 1613) | Floor rack hinge loop (Dr. 1726) |
| Hatch hinge butt (Dr. 1614) | Floor rack link holder (Dr. 1727) |
| Hatch cover lock lever guide (Dr. 1615) | Floor rack pin bearing (Dr. 1728) |
| Hatch plug lift ring (Dr. 1630) | Floor rack bearing (Dr. 1729) |
| Hatch cover lever anchor (Dr. 1653) | Floor rack hinge pin (Dr. 1732) |
| | Door arrangement (Dr. 1391) |

- Number of cars that can be changed monthly at each shop.
- Number of cars that can be changed in all shops per month.
- Length of time that it will require to make changes on all cars owned.

The circular further states that in order to improve refrigeration of cars as at present constructed, all railroads owning refrigerator cars will immediately arrange to apply floor racks in accordance with drawing No. 1387, where they have not already been so equipped. It is desired to have all refrigerator cars requiring such racks equipped within the next twelve months; therefore, there should be no delay in beginning this immediately. Monthly reports will be furnished to the general supervisor of car repairs, Washington, D. C., showing the number of cars equipped

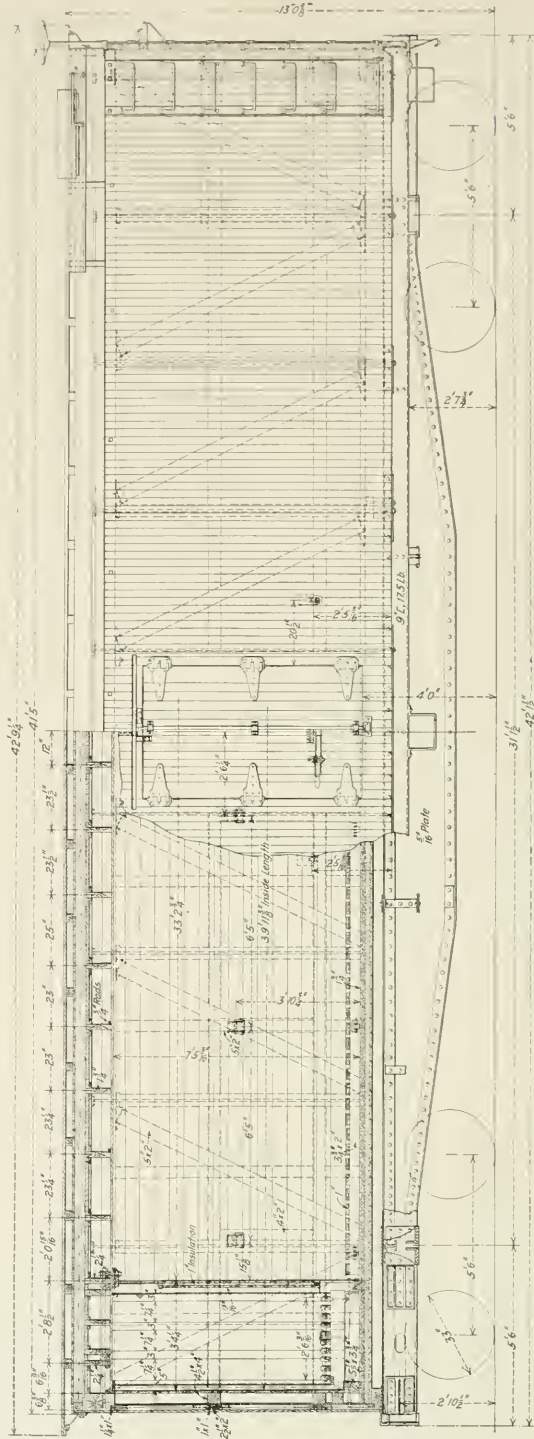
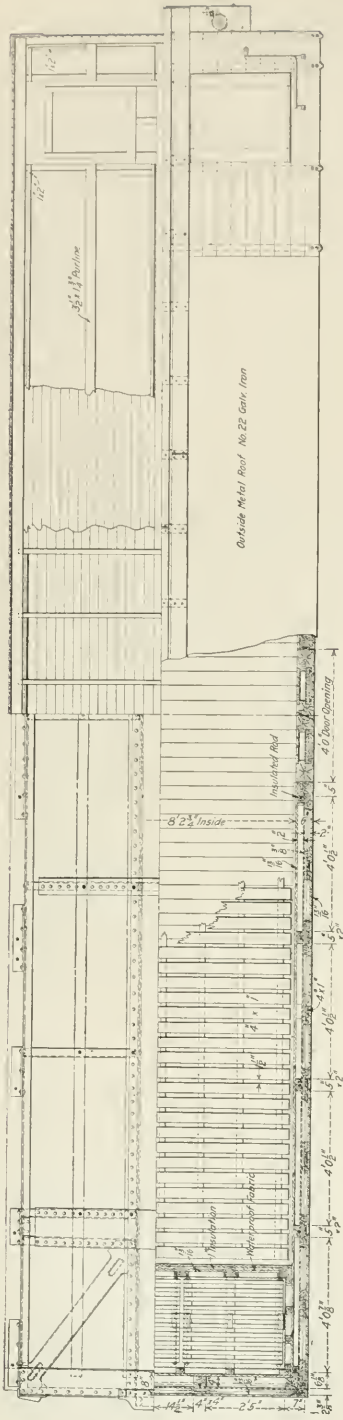

Elevation and Plan of U. S. R. A. Standard Refrigerator Car (Drawing No. 1386)

side sills, mortised to fit the angle on the side sill member of the underframe. There are 12 intermediate 5-in. by 2-in. side posts and 12 diagonal braces of the same material. There are two side belt rails $4\frac{1}{2}$ in. by 2 in., located 2 ft. $\frac{1}{4}$ in. and 4 ft. 10 in. above the bottom of the side sill, respectively. The side plate is $8\frac{3}{4}$ in. by $4\frac{3}{4}$ in. There are two intermediate 4-in. by 4-in. end posts and two end belt rails $4\frac{1}{2}$ in. by 4 in. The corner posts are $6\frac{1}{8}$ in. by 7 in. The roof framing consists of a ridge pole 5 in. by $4\frac{1}{8}$ in. and two purlines $3\frac{1}{2}$ in. by $1\frac{3}{4}$ in., with $1\frac{3}{4}$ -in. carlines having $\frac{3}{4}$ -in. tie rods located at every other carline. The end plates are $6\frac{1}{4}$ in. by 8 in., gained out to receive the insulation. The door posts are oak members $13/16$ in. by $3\frac{1}{4}$ in. The roof has 13 16-in. roof boards which are covered with a No. 22 gage outside metal roof. The inside and outside sheathing of both the sides and ends is $13/16$ in. thick. The inside of the cars is provided with a floor rack of 1-in. by 4-in. boards fastened to four $3\frac{3}{4}$ -in. by 2 in. stringers. The floor racks are hinged at the sides.

UNDERFRAME

The underframe center sill is of the fishbelly type, being made up of two 5 16-in. web plates located $12\frac{7}{8}$ in. apart, 25 in. deep at the center and having at the top 4-in. by $3\frac{1}{2}$ -in. by 5 16-in. angles and at the bottom 4-in. by $3\frac{1}{2}$ -in. by $3\frac{3}{8}$ -in. angles on the outside and 4-in. by $3\frac{1}{2}$ -in. by $7/16$ -in. angles on the inside of the plate. There is a $20\frac{1}{2}$ -in. by $\frac{1}{4}$ -in. cover plate extending the full length of the car be-

and grooved sheathing. The ends are substantially the same with the exception of the thickness of the belt rails and air space, which is 4 in. The section through the door is precisely the same as that through the sides. No break is made in the insulation around the corner posts. The waterproof insulating fabric is of No. 350 drill, which is a cotton cloth weighing approximately $3\frac{1}{2}$ lb. per 100 sq. ft. and thoroughly saturated with an odorless waterproofing compound, preferably of an asphaltic base of approximately the same consistency of waterproof compound used on insulating paper. It extends continuously from side sill to side plate and from door post to door post around the end of the car.

The flooring is made up of a $13/16$ -in. blind floor at the bottom, a layer of waterproofing compound on top of this, then a layer of 2-in. cork insulation, another layer of waterproofing compound and a $1\frac{3}{4}$ -in. tongued and grooved floor with the joints white leaded. The quantity of waterproofing compound used in each of the two layers is 30 gal., and the specifications for this material require that it must be perfectly waterproof, having a melting point of not less than 175 deg. F.; it must be pliable at zero, highly adhesive when hot, not sticky when cold, and absolutely odorless.

The roof is made up of a $13/16$ -in. ceiling, on which is laid a layer of waterproof insulating fabric. A blind roof $13/16$ in. thick supports three layers of insulation, having a total thickness of $2\frac{1}{2}$ in., on which is laid a layer of the waterproof insulating fabric. A slight air space is left between this and the roof boards, which are $13/16$ -in. thick. An

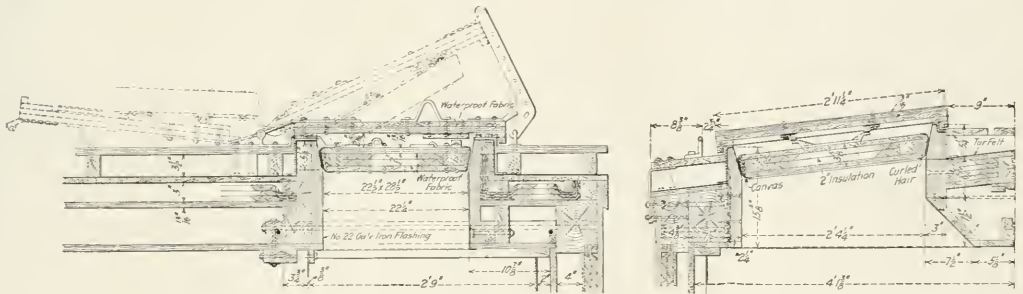

Sections Through Ice Box Hatch for Standard Refrigerator Cars

tween the end sills. The side sills are 9-in., 17.5-lb. channels with 4-in. by $3\frac{1}{2}$ -in. by $3\frac{3}{8}$ -in. angles riveted to them to support the wooden side sills of the car body. The end sills are channels of the same section as the side sills. The cross-bearers are made of $\frac{1}{4}$ -in. pressings with 6-in. by 7 16-in. top cover plates and 6-in. by $3\frac{3}{8}$ -in. bottom cover plates. The body bolsters are built up of $\frac{1}{4}$ -in. pressings with a 6-in. by $7/16$ -in. top cover plate and a 6-in. by $3\frac{3}{8}$ -in. bottom cover plate. The diagonal braces at the corner of the car are made of 5 16-in. plate pressed to channel section.

INSULATION

The specifications call for two courses of 1-in. insulation in the sides and ends and three courses with a combined thickness of $2\frac{1}{2}$ in. in the roof. The floor insulation is of pure cork board 2 in. thick. An option of hairfelt, Keystone hairfelt, flaxlinum and linofelt is provided for the insulation. The side walls of the car consist of an inside sheathing $13/16$ in. thick, to which is applied on the outside a layer of waterproof insulating fabric. This sheathing is fastened to two belt rails $4\frac{1}{2}$ in. by 2 in., a 2-in. air space thus being provided. To the outside of these belt rails is nailed a $3\frac{3}{8}$ -in. shiplap blind lining, on which is applied waterproof insulating fabric, the 2 in. of insulation, another layer of waterproof insulating fabric and the $13/16$ -in. outside tongued

outside metal roof is to be applied on top of this. A layer of $\frac{1}{2}$ -in. insulation 4 in. wide is mortised into the side plate at the outside for the full length of the car in order to provide insulation at points where the carline tie rods pass through the side plate. On the outside a 1-in. layer of insulation is applied in the air space between the ceiling and the blind roof, being folded over and held in place by a $2\frac{1}{2}$ -in. by 1-in. nailing strip.

ICE COMPARTMENTS

An ice compartment is located at each end of the car. They have stationary insulated bulkheads and an ice receptacle of the basket type. The distance from the outside end of the car to the inside face of the bulkhead is 4 ft. $\frac{1}{4}$ in., the distance between the bulkheads being 33 ft. $2\frac{3}{4}$ in. The bulkhead is made up of two layers of tongued and grooved 13 16-in. boards, with a layer of 1 in. insulation between them, and it is supported by four intermediate 3-in. by $3\frac{3}{4}$ -in. oak posts. The opening at the top of the bulkhead is 14 in., having a No. 20 wire $\frac{1}{4}$ -in. mesh galvanized screen. The opening below the bulkhead is 12 in. The ice basket is a screen made of No. 7 wire with $1\frac{1}{4}$ -in. by $1\frac{1}{4}$ -in. mesh, which is galvanized after weaving. There is a space of 2 in. between the basket and the walls of the ice compartment. The inside dimensions of the ice basket are 2 ft. 9 in. deep by 7

ft. 10 in. wide and 6 ft. 3 3/16 in. high. A 4-in. air space is provided between the wall of the ice box and the end of the car. As in the sides, the end consists of 3/4-in. ship-lap sheathing with two 1-in. layers of insulation and a 1 1/16-in. outside sheathing. The ice is supported on 3-in. by 1 1/2-in. oak grates, which are carried on six 5-in. by 3-in. wooden members. The sides and the ends of the ice box are covered with No. 24 galvanized iron for the full height of the box. The drip pan is made of No. 12 galvanized steel with the sides and the ends flanged upward.

The ice hatch has an opening 22 3/4 in. by 2 ft. 4 1/4 in. The hatch frame is 1 3/4 in. thick, supported at the ends by suitable cripples and filling blocks on the inside to substantial blocking extending across the full width of the car and at the outside by a filler block between it and the side plate. In addition to this there is a malleable iron frame 5/16 in. thick and of Z-section, which extends around the upper portion of the hatch. The inside of the hatch passage is covered with a flashing of No. 22 galvanized iron. The hatch plug is made up of two layers of 3/16-in. boards with two 1-in. layers of insulation between them. It is attached loosely to the hatch cover in such a manner that it may freely fit the hatch without binding, but yet so that it can be raised with the cover.

None of these cars have been ordered by the Railroad Administration up to the present time.

PASSENGER CAR CLEANING*

BY E. ELEY

Master Car Builder, Canadian Pacific, Eastern Lines, Montreal, Que.

Cleaning passenger equipment cars is one of the operations all railroads have to expend large amounts of money for yearly, and clean cars is one of the things the traveling public appreciates. Those of us who travel know this from the remarks we hear from passengers. Very few of them, however, know what a vast amount of labor must be spent to keep them clean and in a sanitary condition.

In this paper I will endeavor to conduct them through a train just arriving from a five days' trip across the continent. We will start at the rear end and walk through, noting its condition. If it is in the dry season and ties have been put in the track recently, we have dust covering everything, and it has got into the plush seat covering, carpets, and bedding. Besides this, there is the usual amount of paper, orange peel, bottles, etc.

Before we can start our cleaning we find some of the cars are due to be fumigated, which is done once a month; upper berths have to be opened, and blankets, pillows, berth curtains and mattresses spread out so that the fumes will penetrate every part of the equipment, locker doors and toilets must be opened and all windows and ventilators closed. For an ordinary fumigation one sheet is used, saturated with formaldehyde and hung up in the centre of the car; the car is then closed up, locked and left for at least one and one-half hours, after which it is opened and ventilated for the cleaners to go in. For a thorough fumigation, which is used in cases of actual infection, three sheets are used saturated with formaldehyde and hung up, one in each end, and one in the centre of the car, and the car left closed at least three hours. After this it may be opened and ventilated.

From sleeping cars, the carpets, bedding, seats and seat backs have to be removed from the car for cleaning and airing. To clean these, the following is the usual practice: Blankets and berth curtains are shaken, mattresses are beaten or blown with air, seats and backs are either blown with air or vacuum cleaned. The carpet is first swept off and then blown with air. All this equipment is then laid on racks until the interior of the car is cleaned thoroughly and made ready to receive it again.

The interior of the car is cleaned from the headlining to the floor. First we have to get rid of the dust, deck sash are opened and dust wiped out with a disinfectant solution in the water, dust is got out from between and above the window sash by hammering with the hand, and window sticks covered with a cloth. When we have got down all the dust we can, the floor is swept out. We start again at the headlining and wash it, including the deck sash down to the deck sash rail. All the woodwork below this has to be wiped down, and if necessary washed with Castile soap and warm water, and finally the floor and steam pipes are washed with a disinfectant solution in the water; this includes toilets, under the washstands and lockers. Now it is ready to receive the bedding, etc. When this is stowed away, seats and backs are replaced. The woodwork is gone over and polished, sometimes using a renovator; nickel and mirrors are all cleaned and polished, the carpet is laid, and the final finishing touches are given to the car. Passage ways and vestibule floors are scrubbed and a canvas strip laid down and left there until the train is ready to back into the station. This work takes about 35 hours, and with the exception of washing the headlining and polishing the woodwork where a renovator is used, is performed by two men and a woman, and costs about \$15.50 per car.

This work is performed on observation, sleeping and tourist cars once in seven days, or in the case of Transcontinental trains they are stripped at Montreal or Toronto and Vancouver, which is once in six days. On shorter runs the cleaning given this equipment between stripplings is an ordinary cleaning, consisting of sweeping carpets, dusting and wiping woodwork, cleaning windows, mirrors, nickel, etc., and finally vacuum clean the cushions, backs and carpet, scrubbing floors in passage ways, and vestibules.

We will now take the day coaches. We do not remove seats or seat backs from them, windows are opened and the car is swept out, then dusted down, headlining washed if necessary, floor and steam pipes scrubbed with a disinfectant solution, and if necessary all, or part of the interior, washed down, windows, mirrors and nickel cleaned and polished, seats and backs in the first class cars are vacuumed and the aisle strip cleaned with air, and the car is ready for service. If cars are cleaned in the morning and do not leave until night, they quite frequently have to be dusted again just prior to departure.

We now come to the baggage and express cars. The fish racks are lifted and pits swept out, and then rack and pits scrubbed with clean water without disinfectant, then pits and racks are sprinkled with lime and racks replaced. As necessity requires, these cars are washed down from roof to floor. Being on the front end of trains they get very dirty from smoke from the locomotive. The reason we do not use disinfectant in the water for scrubbing baggage cars is that it would taint some of the commodities carried in them.

Mail cars are cleaned in the same way, except that the floors are scrubbed with disinfectant in the water. This completes the inside cleaning. The outside is cleaned by washing or wiping, according to weather conditions, but the best results are obtained by wiping when it is possible to do so. The windows are occasionally gone over with a little muriatic acid in water whenever necessary to cut the dirt or scum which accumulates, and then washed with clear water; vestibules and steps are wiped down and the brass work polished. This is an ordinary cleaning which the cars receive every time they are in the terminal, but even with this cleaning, in two or three months they become so dirty that the numbers cannot be seen. Then they are given a terminal cleaning which consists of scrubbing them with some approved cleaner and thoroughly washing it off, and the car looks as though it had only just come out of the shops.

We have now gone over the work which has to be performed. Let us take a look at the people who perform it. They are composed of all nationalities, some of whom do make

*Abstract of a paper presented before the Canadian Railway Club.

pretty good car cleaners and others of whom never will. This then is the element with which we have to get this work done, and you can readily see it requires the closest supervision to get it done properly.

I once saw a woman who was on the terminal cleaning and using our standard cleaner put her brush into some fine sand and start to scrub some spots on the outside of the car to remove some excreta which had become dried on so hard that it was almost impossible to remove it without taking off the varnish. This woman was a foreigner and no doubt in the country she came from the practice was to use sand and water to scrub the floors. You can readily understand what it means to educate such people and make car cleaners of them.

To supervise work of this nature requires men of energy and patience, and like the people working under them, require special training, otherwise the class of cleaning deteriorates, then it becomes necessary to make a crusade for better cleaning, and some of our foremen will tell you this occurs quite frequently.

M. C. B. CIRCULAR ON AIR BRAKE MAINTENANCE

The necessity for improvement in the condition of air brake equipment on freight cars has led the Master Car Builders' Association to issue an appeal for closer observation of the interchange rules and standards of the association. At the suggestion of the executive committee a joint meeting of the Committee on Train Brake and Signal Equipment, representatives of the Fuel Conservation Section of the Railroad Administration, and the president of the Air Brake Association was recently held and recommendations for improving the maintenance of air brakes were prepared. These recommendations have received the approval of the United States Railroad Administration and are now being issued as Circular No. 20, which reads as follows:

Conditions throughout the country point to the fact that air brake equipment on freight cars is in need of closer attention than is now being given, and that the Rules and Instructions of the Association regarding air brake maintenance and repairs are not being fully observed. Your attention is called to this matter with a view of bettering operating conditions, and the following is recommended:

First:—That the instructions of the Association covering repairs, cleaning and inspection of freight car train brakes be more rigidly enforced. In this connection, it is suggested that these rules, which are shown on pages 474 to 477, inclusive, of the 1917 Proceedings of the M. C. B. Association, be printed by each road in the form of a circular and posted under glass at each repair and inspection point.

Second:—Interchange Rule No. 60 provides that, "Air brakes bearing cleaning marks nine months old, or older, may, when on repair or other tracks where the work can be done, be cleaned and repaired," and charged to car owner. Inasmuch as inspection shows that the brakes on a great many cars are not now being cleaned, even in twelve months, it is recommended that wherever possible they be cleaned at the expiration of the nine months' period.

Third:—That all roads not equipped with the standard triple valve test rack and the standard air brake hose coupling gage, procure them as soon as possible.

Fourth:—That the number of brakes cleaned yearly by each road should equal or exceed the number of cars owned.

Fifth:—That special attention be given to maintaining brake pipe, brake cylinder, reservoir, retaining valve and pipe secure to the car.

Sixth:—That angle cock and cut-out cock should have operative handle with proper clearance.

The standards of the M. C. B. Association provide for thorough inspection and repairs to the air brake apparatus

every twelve months. The unfortunate conditions existing at present could not have occurred had these standards been adhered to. In order to bring the instructions before the men actually doing the work, the Association has had the rules referred to in the second paragraph of the circular printed in large, clear type. It is hoped that the roads will post copies framed under glass at all points where air brakes are repaired to remove any possible excuse for failure to live up to the instructions due to lack of familiarity with their provisions. These rules are given in full below.

CLEANING AND LUBRICATING TRIPLE VALVES.

The triple valve should be removed from the car for cleaning in the shop, and should be replaced by a triple in good condition. It should be dismantled and all the internal parts, except those with rubber seats and gaskets, cleaned with gasoline, then blown off with compressed air and wiped dry with a cloth.

The slide valve and graduating valve must be removed from the triple piston and retarded-release parts from the body in order that the service ports in the slide valve and other parts may be properly cleaned. No hard metals should be used to remove gum or dirt or to loosen the piston-packing ring in its groove. The feed groove should be cleaned with a piece of wood, pointed similar to a lead-pencil. Bags or cloth should be used for cleaning purposes rather than waste, as waste invariably leaves lint on the parts on which it is used. In removing the emergency-valve seat, care must be exercised not to bruise or distort it.

Particular attention should be given the triple-piston packing ring. It should have a neat fit in its groove in the piston, and also in the triple-piston bushing; once removed from the piston, or distorted in any manner, it should be scrapped. The fit of the packing ring in its groove and bushing and the condition of the bushing should be such as to pass the prescribed tests. The graduating stem should work freely in the guide nut. The graduating spring and the retarded-release spring in retarded-release triple valves must conform to standard dimensions and be free from corrosion. The thread portion of the graduating-stem guide should be coated with oil and graphite before reapplying it to the triple cap.

The triple-valve piston and the emergency valve must be tested on centers provided for the purpose to insure their being straight. The emergency-valve rubber seat should invariably be renewed unless it can plainly be seen to be in first-class condition, which is seldom the case. A check-valve case having cast-iron seat should be replaced with a case having a brass seat. The cylinder-cap gasket and check-valve case gasket to be carefully examined and cleaned with a cloth; but should not be scrapped. All hard or cracked gaskets to be replaced with new ones. Standard gaskets as furnished by the air-brake manufacturers should be used. The use of home made gaskets should be avoided, as the irregular thickness results in leakage and causes triple-piston stem to bend or break.

The tension of the slide-valve spring should be regulated so that its contour be such as will bring the outer end $\frac{1}{8}$ in. higher than the bore of the bushing when the outside end of the spring touches the bushing when entering.

Before assembling the parts after cleaning, the castings and ports in the body of the triple valve should be thoroughly blown out with compressed air, and all parts of the triple not elsewhere provided for known to be in good condition. Lubricate the seat and face of the slide valve and slide valve graduating valve with high-grade very fine, dry graphite, rubbing it onto the surface and the upper portion of the bushing where the slide-valve spring bears, so as to make as much as possible adhere to and fill up the pores of the brass, leaving a very thin coating of free graphite. The parts to be lubricated with graphite must be free from oil or grease.

Rub in the graphite with a flat-pointed stick, over the end of which a piece of chamois skin has been glued. At completion of the rubbing operation, a few light blows on the slide valve will leave the desired light coating of loose graphite.

The triple-valve, piston-packing ring and its cylinder should be lubricated with either a light anti-friction oil or a suitable graphite grease as follows: Apply a light coating to the packing ring and insert the piston and its valves in the body, leaving them in release position, then lubricate the piston cylinder and move the piston back and forth several times, after which remove the surplus from the outer edge of the cylinder to avoid leaving sufficient lubricant to run on the slide valve or seat while the valve is being handled or stored ready for use. No lubrication is to be applied to the emergency piston, emergency valve or check valve.

All triple valves, after being cleaned or repaired, must be tested, preferably on a rack conforming to the M. C. B. design and pass the test prescribed under the subject of "Triple Valve Tests" before being placed in service. Should any of the triple-valve bushings require renewing, such work should be done by the air-brake manufacturers. Triples in which packing rings are to be renewed, slide valve or graduating valves renewed or faced, if the latter are of slide type, should be sent to a central point or general repair station for repairs. When applying the triple valve to the auxiliary reservoir, the gasket should be placed on the triple valve, not the reservoir.

LUBRICATING AND INSPECTION OF THE BRAKE CYLINDERS.

First, secure the piston rod firmly to the cylinder head, then, after removing the non-pressure head, piston rod, piston head and release spring, scrape off all deposits of gum and dirt with a putty knife or its equivalent, and thoroughly clean the removed parts and the interior of the cylinder with waste saturated with kerosene. Packing leather must not be soaked in kerosene oil, as it destroys the oil filler placed in the leather by the manufacturers, opening the pores of the leather and causing it to become hard. Particular attention to be paid to cleaning the leakage groove and the auxiliary tube. Triple valve must be removed when the auxiliary tube is being cleaned. The expanding ring when applied in the packing leather should be a true circle and fit the entire circumference, and have an opening of from 3/16 to 1/4 in.; when removed from the cylinder the ring opening should be 1 1/2 to 1 9/16 in., and with this opening, of course, will not be a true circle.

A packing leather which is worn more on one side than the other should be replaced with a new one of uniform thickness, or turned so as to bring the thin side away from the bottom of the cylinder. The piston should be turned each time the cylinder is cleaned. In putting a packing leather on piston, it should be so placed as to bring the flesh side of the leather next to the cylinder walls. Follower studs to be firmly screwed into the piston heads, and the nuts are to be drawn up tight before replacing the piston.

The inside of the cylinder and packing leather to be lightly coated with a suitable lubricant, using not more than 4 oz., nor less than 3 oz. per cylinder. Part of the lubricant should be placed on the expander ring and the adjacent side of the packing leather, thus permitting the air pressure to force the lubricant into the leather at each application of the brake. No sharp tools should be used in placing the packing leather into the cylinder.

After the piston is entered, and before the cylinder head is replaced, the piston rod should be slightly rotated in all directions, about three inches from the center line of the cylinder, in order to be certain that the expanding ring is not out of place. In forcing the piston to its proper position in the cylinder, the packing leather will skim from the inner walls of the cylinder any surplus lubricant that may have

been applied. It has been found good practice to again extract the piston and remove the surplus lubricant.

All stencil marks to be scraped off or painted over with black paint. The place of cleaning, day, month and year to be stenciled with white paint, preferably on both sides of the cylinder or auxiliary reservoir, or if it is not readily visible, in a convenient location near the handle of the release rod. The bolts and nuts holding the cylinder and reservoir to their respective plates and the latter to the car, to be securely tightened.

The brake cylinder to be tested for leakage after cleaning, preferably with an air gage, which can be done by attaching the gage to the exhaust port of the triple valve before connecting the retainer pipe, or where the latest type retainers are used the gage can be connected to the exhaust port of the retaining valve. In either case, the gage will indicate cylinder leakage on releasing the triple valve after making an application, and when attached to the retainer valve it will also test the retainer and retaining-valve pipe. Brake-cylinder leakage should not exceed five pounds per minute, from an initial pressure of 50 lb.

Each time the triple valve and the brake cylinder are cleaned, the brake pipe, brake-pipe strainer and branch pipe should be thoroughly blown out and the triple-valve strainer cleaned before recoupling the branch pipe to the triple valve. If a dirt collector is used, the plug should be removed, the accumulation blown out and the threaded portion of the plug coated with oil and graphite before replacing. All union gaskets should be made of oil-tanned leather. The use of rubber in unions should not be permitted. Piston travel should be not less than six nor more than eight inches.

ADDITIONAL INSPECTION AND REPAIRS TO CARS.

When the brake cylinder and triple valve are cleaned, the following additional work should be done to the car: Retaining valve cleaned by removing the cap, wiping or blowing out all dirt and seeing that the valve and its seat are in good condition, the retaining position exhaust port open and the valve proper is well secured to the car in a vertical position, pipe clamps applied where missing and tightened where loose, hose and angle cocks turned to their proper position. Pipe joints, air hose, release valves, angle and stop cocks should be tested by painting the parts with soapsuds while under an air pressure of not less than 70 lb., preferably 80 lb., and defective parts repaired or removed.

See that there are no broken or missing brake shoes, brake beams or foundation brake gear, and if the car belongs to a foreign road, a repair card should be made out covering all work that has been done, as per M. C. B. Rules.

The inspection and repairs which have been mentioned should be made to all cars at least once in twelve months.

LOCOMOTIVE SITUATION THROUGHOUT THE WORLD.—British engine shops during the war were put to work on munitions and ordered to build no more locomotives, which would seem to leave America a free hand outside of Britain and her "possessions." Germany is expected to be busy with her own domestic needs. France, always short of locomotives before the war, had five of her six plants in territory ravaged by the Germans. Belgium's eight plants have been dismantled by the Germans. Austria bought most of her locomotives in Germany. Russia's shops have fallen before the enemy and the Bolsheviks. Holland, Denmark and Norway bought in foreign markets. Italy manufactures merely enough for her own needs, as Japan does. No engine works of consequence are in the Balkans, and none of modern type in Turkey. Every railroad in South America is short of locomotives. Asia and South Africa are in a like position. It would seem but a question of when the world can begin reconstruction. And that would seem in its turn to hinge somewhat on finance.—*New York Evening Post*.



SHOP PRACTICE



BILLERICA RECLAMATION PLANT

BY B AND B

More and more during recent years the railroads of the country, seeking for new methods of increasing income and reducing expenditures, have realized the great importance of the so-called "scrap pile" and of the necessity of realizing from materials discarded as unfit for use a greater value than is received when sold as common scrap, or of reclaiming discarded materials for use again on the road. In order to obtain such results reclamation plants have been erected and equipped with machinery and tools to do this work, and one of these plants recently installed is the \$50,000

These machines, whose use can be determined from their names, are primarily and solely used for the reclamation work itself. On the open dock the equipment is: An alligator shear with a 30-in. blade, driven by a 35 h.p. motor and capable of cutting stock up to 3½-in. square at the rate of from 25 to 30 cuts per minute; one tumbler for cleaning second-hand nuts, washers and other material that would be benefited by this process; and one coupler rivet cutter which is operated by air and which has a cylinder 18½ in. in diameter and 20 in. long.

The new valuable-scrap house is 77 ft. long and 28 ft. wide. It is partitioned off into bins or compartments for the sorting of brass, copper, also brass and copper turnings

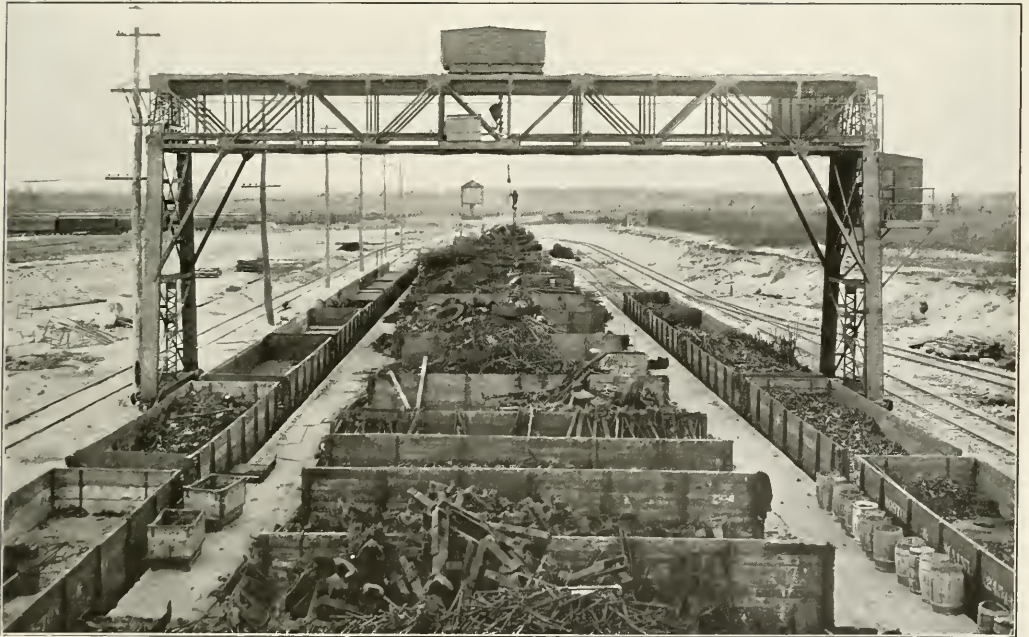

Scrap Dock with Gantry Crane—Boston & Maine Reclamation Plant

plant of the Boston & Maine erected at the new Billerica shops location.

The plant is modern and well equipped, consisting of an open scrap dock, which is served by a 15-ton Gantry crane, a new valuable-scrap house, and the reclamation building itself. The latter is 170 feet long by 28 feet wide and contains the following machinery:

- | | |
|--|-------------------------|
| 2 100-lb. steam hammers. | 2 blacksmiths' fires. |
| 1 1½ in. bar iron shears. | 1 500-lb. steam hammer. |
| 2 triple head bolt-threading machines. | 1 engine lathe. |
| 1 6-spindle nut tapper | Other minor equipment. |

from the shop, lead, secondhand plush from cars, rubber and discarded rubber hose of all kinds, burlap, hemp rope, and other valuable scrap which is classified separately from wrought iron or cast iron, etc.

The largest item of equipment in connection with the reclamation plant is the 15-ton gantry crane, which operates over the entire dock, including one track for cars on each side of the platform. This crane has a spread of 80 ft. and has a trackage of 1,079 ft. It is equipped with a No. 5 type "SA" lifting magnet, the diameter of which is 55½ in.

This magnet has a lifting capacity of 42,000 lb. when handling material such as billets and slabs properly piled. Other equipment in connection with the crane includes a skull-cracker ball weighing 6,300 lb., to be used for breaking up large castings for scrap. The motor on the crane or the crane runway is rated at 27 h.p., and the motor on the trolley travel is 7½ h.p. All motors used are equipped with solenoid brakes.

The scrap material received in cars is removed by the use of the magnet into a sorting bin, where it is sorted in different classes, and that which is to be reclaimed removed and sent to the reclaiming building. The assorted scrap



Scrap as It Is Received at Billerica

is placed in tilting buckets made from old fireboxes, and when these buckets become filled the contents is deposited into the proper bins containing scrap of a particular class, or dumped into cars that are being made up for shipment. The latter method is one that will be followed in all cases where possible, as this eliminates one handling and thus reduces the cost and time of handling.

Scrap from a greater part of the system is forwarded to Billerica, and there the foreman of the plant, with the aid of an inspector of materials, inspects it and determines whether or not it is fit for service again. As much as 3,000 tons have been handled in one month. The method of handling material on the outside scrap dock is carefully watched, in order that in the process of reclaiming any equipment

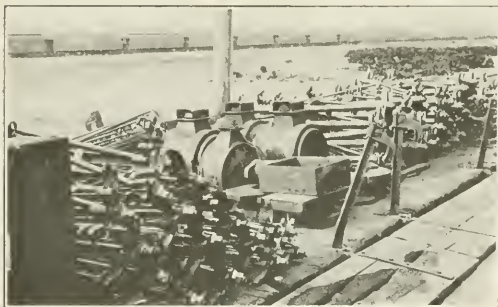

Reclaimed Brake Beams

the profits to be gained by this method may not be lost in excess of labor or time used.

The men employed at the Billerica plant are listed as follows: Ten laborers on the open dock, seven laborers in the bolt yard, four men on brake beams, one machinist, one machinist's helper, one blacksmith, one blacksmith's helper, one laborer on the bench for miscellaneous stripping, one

man to handle reclaimed material. When the blacksmith is not working on brake beams, he is employed repairing fire hooks, brake rods and levers. The laborers are given their board and room. The hours of labor are 10 hours per day and seven days a week.

The principal parts which are reclaimed are bolts, nuts, washers, brake beams, globe valves, pipe fittings of all



Electric Magnet Holding Tires—15,000 lb. Total Weight on Crane Hook

kinds, drawbars and center pins, track shovels, formerly thrown away when the handles were broken, and ¼-in. plate which was heretofore sold as scrap but which is now, when the pieces are large enough, cut to sizes required and used as freight runs. As many as 83 Buffalo No. 2 brake beams and 294 Diamond special brake beams have been reclaimed in one month at a net saving of about 50 per cent in the cost price. A like saving was made in the reclamation of 215 double fire hooks, one hoe, 22 flash bars and 13 single hooks, in one month's time. Couplers are stripped of their parts and the good parts are saved and the remainder sold as scrap. By the adoption of this method of handling scrap a saving of 30 per cent of investment of plant is estimated. The expenditure has been moderate but the outlook promises big results.

RAILROAD MACHINERY CATALOGUES WANTED.—A representative of the Federated Swiss Railroads has asked the Zurich consulate general to obtain catalogues for him from the American manufacturers of mechanical iron rail saws, boring machines for iron railroad rails and wooden railroad ties, mechanical spike pullers, apparatus for carrying and laying iron rails, machines for drawing together rails at joints in tracks, railroad gang cars, propelled by hand and with motor attachment. He informed this office that heretofore all machinery and tools for the Swiss railroads have been obtained from America through agents in Germany, who can no longer supply these needs. For this reason he wishes to place his orders in America or with agents that American manufacturers might appoint in Switzerland. The representative of the Swiss railroads surmises that improvements have been made in the past few years by American manufacturers of this class of machinery, and he is particularly interested in hearing about these.

ACCURACY IN LOCOMOTIVE REPAIRS

Methods of Making and of Fitting New and Repair Parts for Locomotives With Gages and Micrometers

BY M. H. WILLIAMS

MANUFACTURING concerns making machine tools and similar products are continually giving more and more attention to the question of standardizing their product and making the various parts closer to certain prescribed limits. This is done not as a matter of sentiment, but principally on account of being a good business proposition, it having been found that where the various parts that go to make up the completed machine are properly made for size, grade and finish, the cost of assembling is very much reduced. In many respects railway shops can adopt to advantage the good practices, the machine tools, and the methods that have proved economical in manufacturing concerns.

Many of the railway shops have been established a long time and the older methods of performing work have been retained, owing, partly, to the difficulty of procuring modern machines, and also to the fact that they are engaged largely in repair work which does not lend itself to standardization like new work. However, even for repair work it is possible to adopt standard sizes that will eliminate to a great extent the individual fitting of parts that go to make up a locomotive and by the use of later developed machine tools, the grade of finish of the various motion parts, especially the bearing surfaces, may be made equal to the best practices in any shop. Below are mentioned a few methods that are worthy of thought for repairing locomotives and making of new parts.

INTERCHANGEABLE AND OVERSIZED PARTS

It is generally conceded that all parts of the same classes of locomotives and cars should be interchangeable and so made that the various pieces will go together without individually fitting each to some other part. This will make it possible to manufacture and finish the various articles in large batches to gages or micrometer calipers with the assurance that they will properly fit into the place intended. This is largely done for new locomotives and cars and follows the general practices of the builders.

Repair work presents a much more complicated problem on account of the necessity for fitting new parts to holes or surfaces where wear has taken place and where the new part must be a certain amount larger or smaller than the original. However, even for repair work a certain amount of interchangeability may be obtained that will eventually result in reducing the amount of individual fitting. For certain locomotive parts, such as link motion, knuckle pins and their bushings, crosshead pins and various other motion parts, it is possible and entirely practical to establish a system for repair work of what might be called, for want of a better name, over-size standards or step sizes, by which parts for repair work may be finished a definite amount larger or smaller than standard or drawing size and gaged with micrometers or solid gages with the assurance that the parts will fit properly. That is, instead of fitting each link motion pin or similar article to the place where it is to go, they may be fitted to gage or to micrometer readings, or a combination of both. As an illustration, the taper hole in a crosshead may be reamed and the size measured with a taper gage and the pin ground or finished separately to a female gage. The gages for the taper hole and pins are a simple proposition, as will be explained later. The straight holes and pins

to fit them will require a greater number of gages, or in many cases the micrometer calipers may be used.

The explanation of the step sizes can best be illustrated by an example. Assume that the hole in a motion lever bushing is called for two inches in diameter on the drawings. When the bushing is worn it is advisable when making repairs and from a shop standpoint to enlarge the hole to a certain step size, which may readily be done. In the event of a small amount of wear this enlargement may be to 2.010 in., or in the event of greater wear to 2.020 in., 2.030 in., etc., or by greater step to 2.020 in., 2.040 in., etc. This method is followed in place of finishing to no particular size, which would make it necessary to fit the pin individually to each hole. If the hole and pin are each finished to gages it will not be necessary to try the pin in the hole previous to final assembling, which will simplify the operations of fitting these parts.

MICROMETER CALIPERS

Mention has been made of these instruments. They are now gradually being introduced into railway shops and where used invariably result in improvement in the accuracy of the finished article. They also have a good effect on the workmen, as practically every one endeavors to make his work right and takes pride in it. No difficulty will be experienced in getting the men to use them where necessary when the heads of the various departments properly explain their use and the method of reading. If in doubt concerning the use of micrometers it would be well to compare the accuracy and number of good and rejected parts in shops working with and without micrometers. The use of these instruments will naturally be limited to the measurements of articles that are to accurately fit other articles and for locomotive work should be used principally on motion parts, such as link motion pins, crosshead pins, journals, etc. Their use on rough work, such as locomotive frames and parts, where close fitting is not essential, is not contemplated or necessary.

STEP SIZES FOR REPAIR WORK

For the over or under-size step sizes necessary for repair work and with the use of micrometers it is advisable to depart to a certain extent from the regular units of measurement such as $1/64$ in., $1/32$ in., etc., and adopt easily remembered and read decimals, such as .005 in., .010 in., .020 in., etc. This will simplify the use of micrometers. As has been explained, if the original hole is two inches the next enlargement can to advantage be 2.010 in., instead of $2\ 1/64$ in. This does not signify that a departure should be made from drawing sizes such as one inch, $1\ 1/8$ in., $1\ 1/4$ in., etc., but rather that where a hole was originally one inch, the next enlargement should be by steps of .010 in. or .020 in., up to the largest size usually allowed for enlargement. Should this enlargement of a 1-in. hole equal $1\ 1/8$ in., it will be found advisable to start again from that size with the step sizes.

Another point is also well worth consideration. This is a standard method of making the male or female part to a standard size. If the nominal size for a valve motion pin and bushing is two inches, one or the other should be made to a standard gage or size and the other part larger or smaller, as may be necessary. Generally speaking from a

shop standpoint, it is advisable to make the hole to a standard size, such as $1\frac{1}{2}$ in., $1\frac{3}{4}$ in., 2 in., etc., and for a pin to fit freely in the hole a trifle below size, which may be, say, 0.004 or 1.496, 1.746, 1.996 in. By this method standard sizes of plug gages and reamers may be used, and for force fits the male portion can be made the required amount larger than the standard sizes.

MEASUREMENT METHODS

Gages for Measuring Holes.—For measuring the comparatively small holes, such as are found in valve motion parts, three inches and under, an inside micrometer may be used and is preferred by some. However, for the general run of work, solid cylindrical plug gages will be found the more serviceable. For larger parts, such as side rod knuckle pin bushings, side rod brass bushings, or holes above three inches in diameter, the tubular inside micrometer will be found the more desirable where miscellaneous measurements are to be made. Where parts are made in duplicate quantities on machines, the solid gage is to be preferred. The solid plug gages may be purchased from gage makers, but if difficulty is experienced in obtaining the odd sizes they may be made at a reasonable cost in railway tool rooms. In the latter event they should be made from tool steel hardened, or soft steel and heavily pack casehardened. In either event they should be carefully ground to size after hardening. The customary form of plug gage is shown in Fig. 1.

Measuring Outside Diameters.—For measuring the diameter of the straight portions of valve motion lever pins, crank pins and similar work, the outside micrometers will be found very convenient and accurate and much cheaper

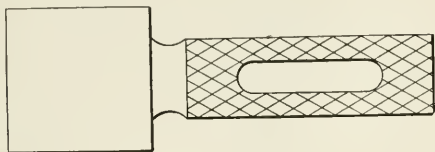

Fig. 1—Standard Plug Gage

than the solid gages that would be required to cover a large range of sizes such as are encountered in repair work. They have the advantage that any size within their range, which is generally one inch, may be measured, and where a pin is to be a certain amount smaller than the hole to allow for running fit, this amount may be measured accurately. That is, for the 2-in. size, the pin may be required 1.997 or 1.996 in., or as found satisfactory from experience.

Gaging Taper Holes.—For gaging the taper holes in valve motion levers, side rods, crossheads, frame bolt holes, etc., taper gages illustrated in Figs. 2 and 3 will be found very satisfactory. They can be used for measuring the diameter of the reamed holes and checking the accuracy of reaming, and also for detecting wear in the parts as they come to the shop. The gage in Fig. 2 shows the sizes stamped on a flattened surface. Different methods of marking at the lines are followed. One method is to mark with an arbitrary number that will indicate the number of pins or bolts that will be required. In many respects it is advisable to mark at the lines the actual diameter of the gage at that point in inches and decimals of an inch, such as 2.000, 2.010, 2.020, etc. By this method the diameter of the large end of the pin or bolt will be indicated by the reading on the gage. Where pins or bolts are marked and put in stock, and in order to avoid too much stamping, the inch marks may be omitted and simply marked 10, 20, 120, etc., the full inch being understood.

Fig. 2 shows in a general way a gage suitable for meas-

uring taper holes such as are found in valve motion levers and ranging from 2 to 2.240 in. at the largest part of the lever jaw, the taper shown being one inch per foot and with steps advancing by .010 in. in diameter. That is, at each line the gage is .010 in. larger in diameter. The first or 2-in. diameter line is shown four inches from the small end of the gage, this extra length being for the purpose of fitting into the hole of the smaller side of the jaw. The spacing of these lines may readily be calculated and for this particular case is .120 in. These divisions may readily be cut on a milling machine, preferably with a V-shaped cutter having a sharp cutting edge. As these gages will often be

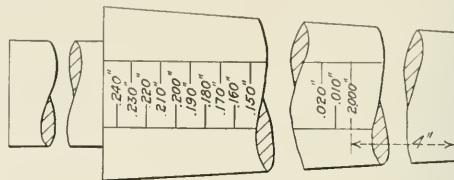

Fig. 2—Taper Gage for Small Holes

used where the light is not good, the lines may with sufficient accuracy be $1/32$ in. wide. The figures stamped on the gage should also be prominent and may to good advantage be from $1/8$ to $3/16$ in. high. Many a good gage has been discarded because the workman was unable to read the markings properly in dark places. It is advisable to mark this form of gage for the standard dimensions called for on drawings for new work by the letters *S T D*. This will call attention to the drawing sizes for particular pins.

Fig. 3 shows a similar gage of larger diameter and for the purpose of reducing weight may be made hollow with the wall about $3/8$ in. thick. These gages may be made cheaply from machine steel or old axles and when finished from $1/32$ in. to $1/16$ in. large they may be ground to the proper size after being heavily pack casehardened. In a number of cases where gages are used only occasionally they can to good advantage be made from cast iron and will last a long time.

For new work this form of gage will answer for gaging the reaming of holes to drawing sizes and when trying them they should enter to the line marked *S T D*. When re-

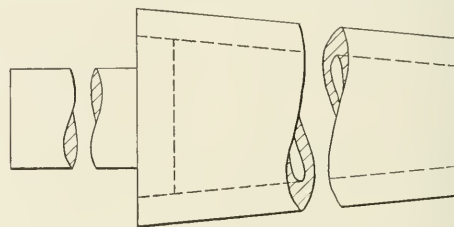

Fig. 3—Hollow Taper Gage for Large Holes

reaming worn holes they may be enlarged only enough to allow the top face of the part to come flush with one of the lines on the gage. The size stamped on the gage will indicate the size of the pin necessary to fit the hole.

Gages for Taper Pins.—For measuring the taper portion of the pin a gage as shown in Fig. 4 will answer very well. This may be used to gage the diameter of pins used for new work, in which event the diameter of the hole at the large end should equal the standard diameter of the pin. This may be gaged by the male plug gage for holes, previously

mentioned. This gage may also be used for gaging pins for repair work that are larger than standard. In this event the pin will only partly enter the gage, as shown in Fig. 5, and will serve only to test the taper and not the size.

Where these pins are ground on cylindrical grinding machines with properly trued grinding wheels and the angle of the table properly set, as may be determined by the gage shown in Fig. 5, the diameter may be measured by micrometer calipers by taking the readings over the large end of the taper, shown at *A*. The finished size should be the same as shown by the readings at the lines of the taper plug gage previously mentioned. By this method the pins will fit

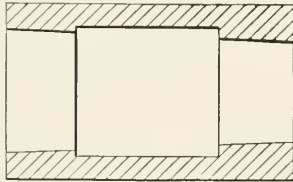

Fig. 4—Gage for Tapered Pins

properly into holes that have been reamed to the plug gage and the necessity for testing each pin in the place where it is to go will be avoided.

Gages as shown in Fig. 4 are preferably made from tool steel, hardened and ground for the smaller sizes. For the larger sizes, such as are used for piston rods, crosshead and knuckle pins, cast iron is often used, which answers very well.

METHODS OF FITTING

By the use of the cylindrical and internal grinding machines, gages and micrometers, such as have been mentioned, the following methods of making repairs to valve motion levers, side rods, crossheads, etc., and the bushings and pins used in connection with them, may be followed:

First.—Straight holes such as found in bushings and in levers not worn enough to warrant repairs of new parts. These may be tested with the plug gages to ascertain if they are to standard size or to any of the step sizes above the standard.

Second.—Same parts as above, slightly worn, which may be refinished on the internal grinding machine without re-

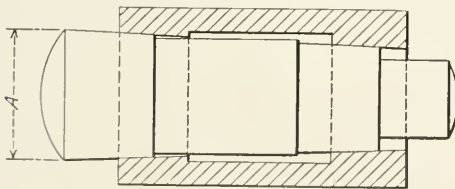

Fig. 5

moving the bushings from the rod. In this case the lever, rod or part may be clamped to an angle plate bolted to the table of the internal grinder and the machine adjusted so that the spindle will grind central with the hole. The hole may then be ground to one of the step sized plug gages. This will finish the hole cylindrically and of one size for its entire length and produce a good bearing on the pin. When holes are only slightly worn it is difficult to ream or lap them and produce a round hole of equal diameter from end to end. With hardened surfaces the only other method would be lapping with lead lap, which is not entirely satisfactory for the various bearings used on locomotive motion parts.

Third.—Bushings badly worn so that renewals are necessary: In this case, after removing the bushing, it is well to examine the hole from which it is removed and if it is found tapered or out of round it may be ground on the internal grinder to insure the next bushing fitting properly. This may seem to be an extra operation. However, this practice will eventually result in an improvement in the levers and in the security of the bushings. When grinding these holes it is well to grind to a plug gage for convenience in determining the proper size for the bushing to be applied. With the holes in the levers ground to one of the plug gages, the outside of the bushing to be applied may be ground on the cylindrical grinder a certain amount larger to allow for force fit, similar to the practice with new bushings applied to new standard parts.

When forcing bushings in place the hole will be compressed a certain amount, depending on the thickness of the walls and other causes. This will have the effect of reducing the diameter of the hole in the bushing. For the average repair work the hole in the bushing should be ground after applying to insure proper size and good bearing surfaces.

It is entirely within the range of possibilities, especially for new work, to grind the holes in the bushing previous to applying them, a slight amount large to allow for this compression. This practice would make it possible to grind the holes in these bushings in quantities, which would be

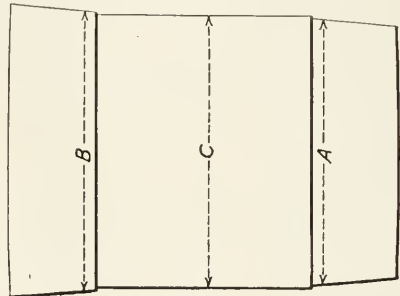

Fig. 6

cheaper than finishing them singly. If the practice of finishing holes into which the bushings are to be applied to plug gages and grinding the outside of the bushing is followed, there would be no difficulty in arriving at the proper amount to allow for compression of the hole in the bushing. Generally speaking, the outside of the bushing should be from .0015 to .002 larger for each one inch in diameter than the hole. The holes in the bushings will compress about one-half that amount. This, however, will vary with different thicknesses of bushings. If the conditions were as mentioned, the outside diameter of a nominal 2-in. bushing would be 2.004 in. and the hole if required to be 1 3/4 in. should be finished .002 in. large, or 1.750 plus .002, equalling 1.752 in.

Fourth.—New bushings used in connection with pins having taper ends as shown in Fig. 6: When applied to repair work these bushings can in the majority of cases have standard sized holes, similar to those required for new work. When the taper holes in the companion lever have been worn or reamed a large amount, it will be necessary to go to a larger sized hole in the bushing on account of the taper hole in the smaller hole jaws equalling the size of the standard straight body of the pin.

With reference to Fig. 6:—The largest part of the taper *A* can only be equal to the body *C* and obtain a full bearing for the smaller taper end of the pin. When the taper *A* exceeds the dimension of *C* it is advisable to make the bush-

ings and body of pin *C* considerably larger. This may be increased by certain increments as may be decided on. That is, assuming that dimension *C* when standard is two inches, the next increase for bushings may be to 2.100 in. and the next to 2.200 in. The size of these steps will be largely governed by the degree of taper and space available for the bushing. Generally, where tapers are one inch per foot, steps of .100 in. will be found satisfactory. This point can readily be determined by calculation or laying out the work on the drawing board. By adopting some standards of step sizes, or as they may also be called, over sizes for repair work, it will be possible to make these over sized bushings in large quantities, bored to approximately the correct size. Where hardened bushings are used they may be kept in stock all hardened. When applying them it will only be necessary to turn or grind the outside of bushings to fit the hole in part where it is to be applied and to finish the hole. Or to put it somewhat clearer, when the taper *A* is smaller than body *C*, standard bushings and pins can be used. Where the taper in lever has been reamed a very large amount one of the step sizes above standard should be used. This would apply where both the bushing and pin are renewed. If the pin is only slightly worn on the body *C* and is otherwise good, it may be found more economical to regrind the pin and select or make a bushing to fit it, on account of the pin being the more expensive. For this purpose the small step sizes, such as .010 will be found very convenient if kept in stock in small quantities.

Fig. 7 shows suggested sizes for side rod knuckle pins

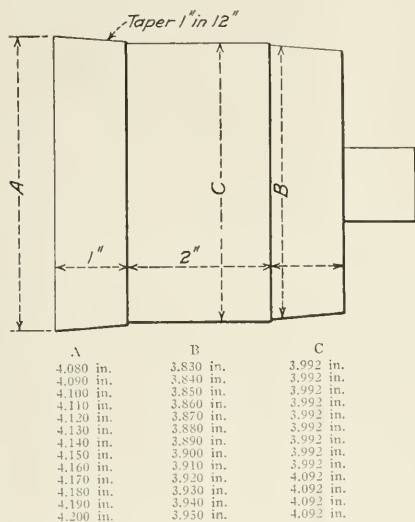
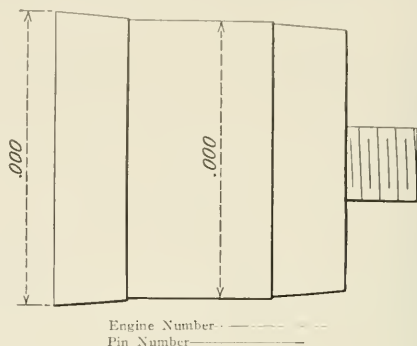

Fig. 7—Suggested Sizes for Side Rod Knuckle Pins

having taper of one inch per foot, which general scheme will also answer for any similar design of pin. As shown, the large end of pin *A* would agree in size with the taper plug gage in Figs. 2 and 3. The dimension *C* should be a trifle smaller than the plug gage for companion bushings, to allow for lost motion, and is here shown 3.992 in. or .008 in. smaller than four inches, which would be the size of the plug gage for the bushing. The dimension *B* will agree with the taper if made continuous from end to end and need not in practice be measured. It is given in the table for the purpose of showing when it is as large as *C* which then makes it necessary to go to a larger step size. In order to

avoid odd decimals, the largest diameter of pin at *A* is shown 4.080 in., which is approximately correct for the dimension *C*. The step sizes of the taper are shown advancing by .010 in. and on the tenth size the straight part of pin *C* is increased .100 in. or to 4.092 in. and would be correct to fit bushing ground or finished 4.100 in. diameter.

From a manufacturing and repair point of view this method of sizes has several advantages. In manufacture the pins may be roughed out in quantities with the straight part *C* a slight amount above size to allow for final grinding and only in certain sizes, or as here shown 3.992 in., and 4.092



Allowances for running fits on pins from 1 in. to 3 in. in diameter are to range from .002 in. to .003 in. For knuckle pins from .007 in. to .010 in. For crosshead pins from .012 in. to .016 in.

Fig. 8—Suggested Form for Showing Pin Size Requirements

in. On account of the varying sizes of taper ends that would be required to meet conditions of worn and re-reamed rods it is a question if all the sizes as shown in the table should be kept in stock. Preferably the pins should be made with the largest taper for each straight size *C*. That is, according to this table pins could be made with *C* measuring 3.992 in. and 4.092 in. and the largest end 4.080 in. and 4.180 in. When finishing the pins they can be ground or turned to fit the female gage as far as the taper is concerned and measured at the large end *A* for diameter. Where the taper is finished in this manner the pin should fit the tapers in the rod perfectly. Where casehardened pins are used they may be all roughed out to sizes mentioned, the necessary keyways cut and holes drilled and casehardened in batches and put in stock until required. By roughing out the straight part *C* approximately .010 in. large, there would be no danger of finishing below the hard surface where the pins are well pack casehardened. There would be no objection to going below the casehardened surface on the taper ends, as would be necessary to obtain the varying sizes required.

Where grinding machines have not been installed these pins may be made up as mentioned above and carbonized only; that is, put through the casehardening process, but instead of quenching, allow the pins to cool slowly, preferably in the casehardening boxes. The surfaces can then be turned the same as soft tool steel and fitted to gages, as mentioned above. After the pins are to correct size they may be heated and quenched to harden the surface the same as when hardening tool steel. Where hardened bushings are used they may also be made in quantities and with the hole reamed or bored enough small to allow for final finish. The outside may be roughed out large enough to meet requirements for average conditions of rod holes. These may then be casehardened or carburized in batches and the outside ground or turned to the required size to fit the rods or the place where

they are to be applied and finally hardened by the regular methods followed with tool steel.

CONCLUSIONS

The methods of performing the various operations and measuring as has been explained are somewhat of a departure from the regular railway practices and may at first appear difficult to put in practice. It would in many shops require a number of gages, micrometers, etc., as well as calculations and study to arrive at the proper methods and step sizes to meet local conditions and designs. This article has only attempted to deal with the question in a general way.

The general effect of introducing micrometers and solid plug gages will be that the work will be finished closer to the required size largely from the fact that the workman will know how much a piece is large or small. This is difficult with other calipers except for the most experienced workmen. As a result of accurate measuring the habit of close sizes will become general and make it possible to finish parts separately with the assurance that they will fit properly when assembled, or to consider any two parts that are to go together, say a side rod knuckle pin and the rod bushing. The bushing may be finished to a solid plug gage or micrometer exactly four inches and when measured by this method would be known to be correct. The pin fitting with this bushing can then be finished say .008 small or 3.992 inches. There will be absolutely no necessity of trying two parts together. This in many cases will eliminate carting the rod to the machine when the pin is finished and possibly making several trials for size as is at times the practice where close measurements are not the practice.

The above deals with straight surfaces. The taper portions of various pins, piston rod ends, etc., may also be made interchangeable or to cover size to fit where wear has taken place by the use of gages shown in Fig. 4. Also the place where the pins are to go may be reamed and gaged by the taper plug gages, Figs. 2 and 3. The taper size of the pins, as has been explained, may in most cases be measured by micrometer calipers by taking readings over the largest part of the taper. With the size required for the largest end of the taper definitely measured and also the straight hole into which the pin fits likewise measured, blanks may be filled out giving the necessary data for the finish of the pin, a suggested form being shown in Fig. 8, on which the sizes can be filled in. Also data as to the amount of allowance necessary for flow of oil or lost motion may also be given. This will have the effect of reducing these dimensions to exact amounts and establishing a uniform practice. With this information the grinder operator can readily grind the pins to the required size both on the straight and taper surfaces, and with the assurance that they will fit.

The eventual results of adopting methods as has been explained will be that the companion parts can be made independent of each other and avoid a large amount of carting of heavy parts about the shop. This, however, is only secondary to the fact that by adopting a system as has generally been explained, the parts will fit properly and will result in saving when erecting and also improve the wearing qualities. Or looking at this question from a manufacturing concern's standpoint, the time saved when assembling the new or repaired locomotive on account of all parts fitting properly will more than pay for all gages and appliances that may be required.

Costs.—The methods, as have been explained, will involve some costs for appliances and machines and considerable study in arriving at the proper allowances for step sizes, lost motion, drive fits, etc., for the various locomotive parts. On the other hand it will be possible to manufacture in quantities the various locomotive parts to a semi-finished state

and allow the proper amount for final finishing to the required size to fit the worn and re-reamed places where they are to be applied. This will have the effect of reducing the total cost of making articles and also the amount of delays waiting on parts. Or in other words the parts may be made up in large quantities. One of the principal savings will result from the fact that parts will fit properly and avoid delays in assembling the locomotive and delays on the road.

LOCOMOTIVE AIR BRAKE TESTER

BY E. A. M.

In the drawing will be found the essential details of construction of an air brake testing device for use at locomotive inspection pits, which makes possible the completion of the necessary brake equipment tests on arrival at the terminal in about 12 minutes.

Essentially, the device is a crane for supporting the inspector's test gage and orifice valve with suitable connections to the signal and train lines, at a height such that it may be swung into the cab at the gangway, with the equipment within convenient reach of the inspector conducting the tests. The test equipment is supported at the end of a telescopic horizontal arm, which may be closed and swung out of the way parallel to the track when not in use. The test equipment is coupled up to the train and signal lines at the rear end of the tender by means of hose and standard coupling, from which pipe lines lead along the side of the inspection pit and up through the base of the crane. From the upper end of these pipes hose connections of sufficient

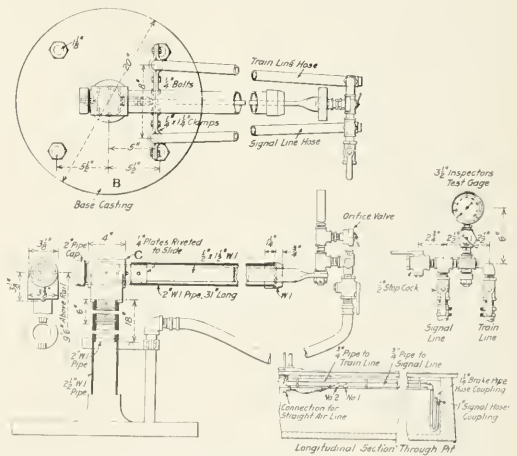

Crane for Supporting Locomotive Air Brake Tests Apparatus at Inspection Pits

length to provide freedom of movement for the swinging and extension of the arm, lead up to the end of the arm. To provide for locomotives equipped with combined automatic and straight air brakes, a special hose connection is tapped into the signal line in the inspection pit. When not in use this connection is closed by plug cock No. 2, as shown in the longitudinal section through the pit, and when in use the connection to the locomotive signal line is closed off by means of cock No. 1.

The upright member of the crane is a piece of 2 1/2-in. wrought iron pipe supported in a cast iron base 20 in. in diameter, which is bolted to a suitable foundation beside the pit and so located that it stands directly opposite the

gangway when the locomotive is spotted over the pit. Resting on the top of the 2½-in. pipe is a special tee forging, to a downward projection from which is attached by means of taper pins, an 18-in. length of 2-in. wrought iron pipe. This fits inside the larger pipe and supports the horizontal arm. Where the forging rests on top of the 2½-in. pipe it is provided with lugs which fit into corresponding notches in the top of the pipe, to hold the horizontal arm parallel to the track when the device is not in use.

The horizontal arm is a piece of 2-in. wrought iron pipe, one end of which extends through a hole drilled in the special forging, to which it is attached by three taper pins. The pipe is about 30 in. long. The telescopic member is a piece of ½-in. by 1½-in. wrought iron, which slides through a special wrought iron cap on the swinging end of the horizontal arm. To the inner end of this piece are riveted two pieces of ¼-in. plate cut to fit the inside of the pipe, to keep the sliding arm in proper alignment.

To the outer end of the sliding arm is attached the test equipment. This consists of an inspector's test gage, in the line immediately below which is a tee to receive the orifice valve. Below the orifice valve is another tee, in the lower end of which is screwed a special stud by which the whole equipment is attached to the sliding arm. The connection to the signal and train lines enters the horizontal flange of this tee. Three ½-in. stop cocks complete the equipment, one each in the signal line and train line and one to provide for blowing out the whole apparatus.

After connecting the pipe lines in the pit to the signal and train lines at the rear end of the tender, the necessary tests may all be conducted by one man in the cab. Where locomotives pass over the inspection pit headed in both directions two of these devices are needed, placed on opposite sides and near opposite ends of the inspection pit.

SOFT GRINDING WHEELS*

BY HOWARD W. DUNBAR

Normally, in most grinding departments, the tendency both on the part of the grinding machine operator and his foreman is to use harder and harder wheels. The reason for this seems to usually come from the feeling on their part that because the wheel lasts longer it is naturally a more economical wheel to use. This is unquestionably a mistaken idea. Wheels are only an economical proposition when they do wear out. Now do not draw a wrong conclusion from this statement, because there is a wide difference between wheels wearing out and producing a large number of parts and those that wear out with a small production.

Soft wheels are only relatively soft. So to assume because a wheel is on a low scale in the grade list that it is a soft wheel is incorrect reasoning because it can only be soft to the grinding engineer's mind when it is free enough to cut rapidly, and in order to perform in this manner it must be soft. The grade list is merely a means for identifying certain kinds and types of wheels so that they may be readily reproduced.

The degree of softness or hardness of the wheel is best determined by its cutting action, its productibility and performance rather than by the position it occupies in any particular grade list. To go a bit beyond the usual understanding of a soft wheel, one must take into consideration the type of machine that the wheel is to be used with, the kind of material that such a wheel is to grind, the mechanical dimensions of the wheel itself as related to the dimensions of the work it is to grind. To illustrate: A wheel of a given diameter and width of face performing a grinding operation upon a piece of hardened tool steel 2 in. in diameter acts in grade (which means its degree of softness or hardness), quite differently than it would were it grinding upon a piece

of the same steel 4 in. in diameter. This, to the grinding machine engineer, is logical reasoning because in the two cases cited the arc of contact is different, and the arc of contact, width of face of the wheel and radial depth of cut are factors which cause a wheel to act either hard or soft.

I have often had occasion in talking with some operator in a grinding department who felt that he was more or less in trouble because his wheel was wearing out rapidly or glazing and filling and he could not produce the large number of pieces per day that he had hoped, to receive in reply to my question, "Have you used a soft wheel?" the answer, "Oh, yes, this wheel is a K wheel." In his mind that wheel was soft because it occupied the position in the low scale of the grading list. He had given little thought to the fact that he was grinding work eight, ten or twelve inches in diameter. In each case the K wheel might have been quite a bit too hard for the operation and again undoubtedly he had paid little attention to the fact that his speeds of work revolution could be of so great assistance to him in causing that wheel to act in a proper manner.

When considering wheel grades to determine the correct one to use, the following points should be kept in mind:

1.—That the grade letter has little meaning in so far as the wheel action is concerned, it only serving as the means of identifying that particular wheel.

2.—The diameter of the work will vary the cutting action of the wheel. The smaller the work the harder the wheel may be and the larger the work the softer it must be, of course, assuming that the diameter of the wheel is the same.

3.—The larger the diameter of the wheel the harder the wheel will act. The smaller the diameter of the wheel the softer it will act, the diameter of work remaining the same in both cases.

4.—The wider the face of the wheel in contact with the work being ground, the softer the wheel must be to grind rapidly.

5.—Work speeds are provided for the purpose of varying the cutting action of the wheel; in other words, so that the wheel may be made to act soft or hard.

6.—The grain size affects the apparent grade of the wheel, finer grains appearing hard while coarse grains appear soft in their action, regardless of the bonding grade.

After all, even though the tendency be in the direction of hard wheels today, and when we say hard wheels we mean harder than necessary to perform a given operation, the day will come when operators will realize that the life of the wheel is a secondary consideration, that the number of pieces ground is of prime importance and there can be no question as to the productibility of soft acting wheels as compared with one that is hard, requiring frequent dressing to keep its face open enough to grind rapidly. It probably is a fact that 75 per cent of the defects in grinding operations can be charged to the use of too hard a wheel. Chatter marks are produced by a hard wheel. Hard wheels generate more heat in the grinding operation which changes the shape of the pieces being ground and makes more difficult the possibility of round work. Hard wheels fill and glaze, causing blemishes in the finish. Hard wheels won't "bite," as the grinding machine operator would say; that is, they do not cut freely. Hard wheels require infinitely more power, at the same time accomplishing less work. Hard wheels cause abuse to the machines, principally the spindle bearings. Hard wheels are the bugaboo of every grinding department.

RAILWAY CARS OF REINFORCED CONCRETE.—The London Times reports that experiments are being made at the plant of the Ebbw Vale Steel Company in the construction of railway cars of reinforced concrete. Experiments are being made in the United States along similar lines but as yet nothing of a definite nature has materialized.

*Taken from Grits and Grinds.

TED SYMINGTON—NO SLACKER

BY A. J. T. CATE

As the one o'clock whistle stopped blowing, Ted Symington, the general foreman at Mt. Clary, turned on his heel and started for his office. "The end of a perfect day for mine," he said bitterly, as he recalled that he was to have been on his way to Jackson City an hour ago, where he was to meet the only girl that had ever meant anything to him, and together they were to have been the guests of friends 20 miles away in the country over Sunday.

Ted had counted on this trip for weeks. He had never had an hour off duty since coming to Mt. Clary and now, after all his longing for this Saturday to come, here he was, not only prevented from keeping his appointment, but the cause of it all meant serious trouble as well. "There'll be some explaining to do over this mess," he muttered, as he strode into his office, "what the outcome will be is more than I know." Hastily throwing off his coat and hat preparatory to washing up, he started to roll up his sleeves when he caught a glimpse of himself in the glass over the washbowl, and the sight made him pause a moment and contemplate his condition.

Long noted for his clean and orderly personal appearance, he wondered what the folks back in Danby would say if they could see him now. His face and hands were covered with grease and grime, his collar and tie were spattered with oil while his suit was practically ruined. As he gazed into the glass and beheld himself in a condition that three months ago would have seemed impossible to him, he reflected bitterly on the turn events had taken since his appointment as general foreman at Mt. Clary, and he could not help wondering how much longer things could continue as they had been before he would be notified a change was to be made.

To say that things were breaking badly for Ted was putting it mildly.

Nothing went right. The harder he worked, the more hours he put in on the job, the worse matters grew. It seemed impossible to get engines out on time any more, and as for engine failures, Ted shuddered as he thought of the last bulletin he had received that morning, showing five failures for the previous 24-hour period, all of them on Mt. Clary engines and of course up to him to explain. And this reminded him again of his present dilemma this noon which had prevented him from taking his trip.

A Mallet had been run over a derailer on the outgoing lead, a couple of rails had been broken, the driver brake rigging torn off and this had to be removed before engine could be rerailed. The fire cleaner who was responsible for the accident had no authority to handle engines, all of which was bad enough in itself, but what was infinitely worse, the derailment blocked in No. 9's engine at the sand house where the hostler had taken the engine just prior to the accident, and there she was, until the lead was cleared and serviceable.

No. 9 was the limited. Anything causing a delay to that train meant trouble, and on this particular day there was no other engine at Mt. Clary capable of handling No. 9. The entire force pitched in and worked like heavers for Ted, but in spite of their efforts No. 9 left the depot 30 minutes late on account of waiting for an engine.

Ted knew there would be more trouble over this affair than any other that had occurred since his advent as general foreman. In the first place, he had been taken to task several times about men handling engines without authority, and the last time when a couple of engines had been smashed up, the superintendent of motive power had written to the master mechanic in a decidedly caustic manner, and that official passed it on to Ted with a note that made his blood boil when he read it.

As Ted vividly recalled that letter now, the worst of many bad ones he had received since coming to Mt. Clary, and remembering the many recent occurrences for which he had been criticised, it began to dawn on him that after all perhaps he was the wrong man for the job. As this thought took possession of him he hastily crossed the room and closed the door. The consciousness that he had failed overwhelmed him and he wanted to be alone now the better to think about the situation.

He knew of course that matters could not be tolerated long as they were going, but somehow he had felt big enough to pull himself out of the hole. Every game had its "bad innings" he had reasoned, and when he had succeeded in overcoming the feeling that he knew had existed against him from the first, he believed he could make a creditable showing. But now, as he surveyed the situation from a new angle he made up his mind that it was too late. He admitted for the first time to himself that he was powerless to bring about an improvement.

And what made it more bitter for him was the knowledge that he, more than all others, was to blame for his own unfortunate position. His mind went back to the time when he had graduated from college and entered the service as a special apprentice at Danby, the headquarters on the next division east of Mt. Clary.

The master mechanic at Danby, Mr. Allen, had liked Ted from the day he went to work there. While in college he had developed considerable skill as a draftsman, and when this became known to Mr. Allen, Ted got all the jobs of making sketches, drawings and blue prints needed at Danby. The result was that far too large a part of the time which should have been spent in the shop was put in at the drawing board in the apprentice school.

It must be admitted that Ted sometimes uneasily asked himself whether he might not be making a mistake. But the good hearted master mechanic made it very easy for him to neglect the shop experience he needed, for the cleaner jobs and pleasanter surroundings in the office.

Ted did not like working in the wheel gang; he had a secret feeling of contempt for a system that made a man with his education work three months with a bunch of "bone-heads," as he called them, wrestling tires off and on, and the other rough work they were called upon to do. And there was the driving box and shoe and wedge jobs, and other classes of work of a similar nature. With his wide reading on these various subjects he did not consider it at all necessary to put in so much time in each gang, when he already knew the fundamental principles of it all. As for roundhouse work, the roundhouse men he knew were always plastered from head to foot with grease since the company had stopped the practice of wiping the engines, and, frankly, roundhouses did not appeal to him at all.

As time went on the general foreman and his staff at Danby, realizing how Ted felt about doing work of this kind and knowing how he stood with the master mechanic, ceased to comment as to his future mechanical ability, and Ted finally passed out of his apprenticeship without a good working knowledge of many things which he now realized he sorely needed. He was scarcely out of his time before he was called upon to relieve the night roundhouse foreman, who was off on account of sickness. The job was not a strenuous one for a foreman at any time, as the majority of the men were "old timers" and knew every move that ought to be made, so Ted had easy going, and the belief that he was a "comer" was greatly strengthened in the mind of the master mechanic. Mr. Allen never let an opportunity slip by of telling the superintendent of motive power about him, and impressing on that officer's mind that in Ted there was all the essential qualifications for a future master mechanic.

From that time on Ted was frequently used as a relieving foreman, and it was only natural for him to feel that after

all, he was capable of handling about any opportunity that might present itself in the line of supervision. As might be expected, when the general foreman at Mt. Clary resigned to accept a position as master mechanic with another company, Ted was immediately selected for the place by the superintendent of motive power, who gave the master mechanic at Walton, to whom Ted reported, a very flattering account of the new general foreman's accomplishments.

Mt. Clary, however, was a different proposition from Danby. It was the junction point of three divisions and lay at the foot of a 12-mile grade over which all freight trains westbound required from one to three helpers. There was no back shop at Mt. Clary to draw on when short of help, or to do extra machine work when up against it in the roundhouse. Moreover, what machines there were had been sent there from various shops along the road, and represented in the aggregate "a bunch of junk," as one old time mechanic put it, in complaining to Ted one day about what was expected of them, and the facilities they had to do it with. The main shop on that division was at Walton more than a hundred miles from Mt. Clary, and it often required great resourcefulness to keep power going until it could be taken there for heavy work. It required a diplomat, too, to deal with the engine crews on three divisions, and the various division officers, each intent on getting the most out of Mt. Clary. In short, that terminal had the reputation of being a "windy corner" for a general foreman, and the man who succeeded there was regarded as competent for about anything in the line of supervision.

Unfortunately the master mechanic at Walton, who was a mechanic of the old school, and who believed that a foreman to be successful should have a thorough training in all departments, had heard of Ted's apprenticeship days, and how he had "got by" at Danby. With this knowledge beforehand it did not take him long to detect Ted's shortcomings in practical experience, and he was not slow in letting him know it. Finally, the general foreman who had preceded him was a man liked by all. A thorough mechanic, skilled in handling men and in making quick decisions that were acceptable to everyone, he had been able to get results under very difficult circumstances. He had kept engine failures down better than any one else had ever done there.

Ted had got in bad almost immediately after arriving at Mt. Clary. Unaccustomed to dealing with the complex problems that were constantly put up to him, he made enemies at the start. He nearly came to blows with a road foreman over some work reported and not done, and this injured him more than anything else that could have happened, for that official never let a chance go by after that to inform the master mechanic at Walton about Ted's weaknesses. The men soon found out that he was deficient in practical mechanical knowledge and they resented having such a man put in authority over them.

And so matters had gone wrong from the start. Engine failures began to increase, terminal delays were constantly taking place, and Ted was called upon for explanations almost every hour in the day.

With his back to the wall he was fighting bravely. During the past month he had been on the job night and day, and yet results were no better, and now, as he leaned back in his chair, he read the handwriting on the wall. As he got up to reach for his coat, for he had not yet been to lunch, he caught sight of a bundle of letters hitherto unnoticed lying on his desk. Down in the middle of the package was a long, white envelope that he felt instinctively enclosed a letter from the master mechanic.

Reaching over, he pulled it part way out and noticed the word "Personal" underlined, while in the upper left hand corner his suspicion was confirmed by seeing the master mechanic's address. Ted had learned to dread those "personals," and as he held this one in his hand deliberating

whether or not he would read it before going to lunch, he noticed for the first time the display type in a newspaper that had been carelessly thrown on the desk, these words:

YOUR COUNTRY NEEDS YOU

IF YOU ARE HOLDING DOWN A JOB THAT EXEMPTS YOU FROM MILITARY SERVICE WHEN YOU KNOW ANOTHER CAN FILL YOUR PLACE—YOU ARE A SLACKER.

With his gaze riveted on that second line, Ted read it again. "WHEN YOU KNOW ANOTHER CAN FILL YOUR PLACE—YOU ARE A SLACKER," he read. His hold on the long, white envelope loosened, a new light shown in his eyes—"That's me," he muttered, reaching for his coat with one hand while he shoved the paper into his pocket with the other. "You won't have to remind me of it again, Uncle Sam," he said, as he started for the door, leaving the long, white envelope unopened on the desk behind him.

The next day while Mt. Clary was talking about Ted's sudden enlistment and his probable successor, over in Jackson City a girl received a letter which she had read many times: "I hope you will forgive me for failing to keep my appointment, but I had bad luck at the last moment, and then I had to go to the recruiting office, and they got my measure down there—well, it was all off."

WEDGE BLOCK FOR JACKING LOCOMOTIVES

BY JAMES GRANT

The wedge block shown in the illustration will be found useful in engine houses, as they eliminate to a great extent the use of jacks for locomotive work. The use of jacks for raising locomotives, particularly the heavy types now in use, is a hazardous piece of work, especially when it is considered that few engine houses have a solid floor to work from. A set of four of these wedges will be found convenient for spring and spring rigging work, engine truck and trailer work, and changing driving tires. Tire changing used to be looked upon as a job for the backshop, but since the federal laws regarding tire wear have been in operation a month seldom passes in the larger roundhouses without changing one or more sets.

For the large Mallet engines the wedges are particularly adaptable. For instance, if the high pressure engine tires

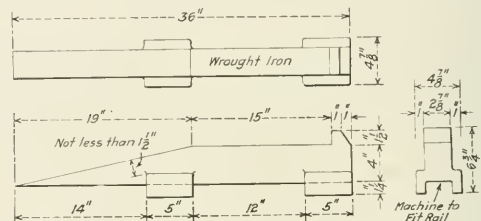

Wedge Blocks Used in the Place of Jacks for Raising Locomotives

have to be changed, run the last pair of drivers of the low pressure engine and the trailer wheels on four of these wedges, at the same time taking care to block the boxes and springs in order to retain all the slack, and lots of space will be found to slip off the old tires and put on the new ones. An engine truck can be run out easily by putting the first pair of drivers on the wedges, taking care to block solid between both of the driving boxes and the frames before moving the engine; also put blocking between the truck boxes and binders so as to keep the center casting in the same position when the weight has been removed.

The wedges, if properly made will hold the rail and the

lugs on the sides prevent any danger from tipping while the heel on top acts as a sure stop when the engine has been pulled up as far as necessary. A wedge can be forged from an old axle or any piece of scrap, and it is considered best to forge the lugs solid. After forging, the inside of the lugs and bottom of the wedge should be machined, so as to make a good fit over the ball of the rail.

The sketch shows the wedge 36 in. long, but this can be varied according to the type of engines handled. The longer the taper the more easy can the engine be run up on to the wedge. The height over the top of the heel might also have to be changed; this depends on how much clearance the brake hangers have from the rail.

It can be readily seen that by possessing a few of these inexpensive wedges considerable time can be saved, as the above methods are far quicker than using jacks. When an engine is on the wedges it is there to stay. When using jacks it is always necessary to block up with heavy timbers.

HYDRAULIC PRESS FOR SHORTENING DRAWBARS

BY E. A. MURRAY

Master Mechanic, Chesapeake & Ohio, Clifton Forge, Va.

A self-contained hydraulic press of simple construction has been developed and is in use at the Clifton Forge shops of the Chesapeake & Ohio for such work as upsetting locomotive drawbars and frame binders. The various operating parts of the complete machine are assembled on a table made up of a heavy cast iron top, of which the stationary resistance post is an integral part. The cylinder is designed for a 10-in. ram and is bolted and keyed to the one end of the table. A 1/4-in. packing leather is secured to the end of the ram with a 3/4-in. follower plate and one inch ahead of the leather the ram is reduced to eight inches in diameter.

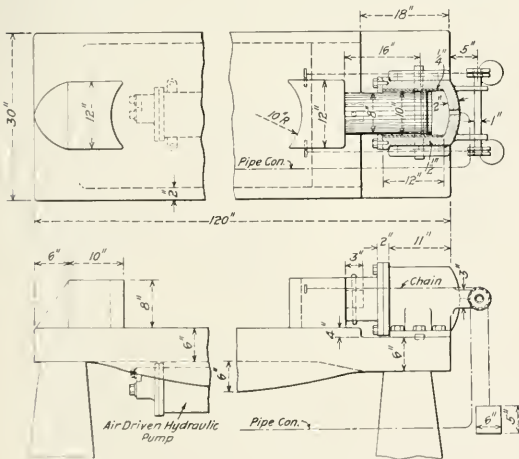

Self Contained Hydraulic Press for Shortening Drawbars

The outer end of the ram is keyed to the movable block, which is a heavy iron casting, sliding directly upon the surface of the table. The ram is counterweighted and suitable brackets for the counterweight pulleys are cast integral with the pressure head of the cylinder.

The press is operated by a pump built from a Westinghouse 8-in. air pump, the air cylinder of which has been replaced by a specially designed cylinder having a working diameter of 1 1/2 in. The pump is operated by compressed air from the shop line.

FULL DAY'S WORK FOR A FULL DAY'S PAY*

BY GEORGE N. DE GUIRE

General Supervisor of Equipment, United States Railroad Administration

The bill which authorized the taking over of the railroads by the Government specifically provided that we would operate them as a war measure, a war measure pure and simple, and with the taking of the railroads every officer and employee on this road ceased to have any connection whatever with it as a corporation, and you, fellow workmen, automatically became Government employees. You then began to draw your pay from the United States Government, and you became an important part of the greatest war machine the world will ever see.

When we took the railroads over, one of the first things that confronted us was a number of requests for increases in pay. You men were not asking for a nickel, but the four train service brotherhoods were in on one concerted movement. Mr. McAdoo said; "We do not want to take care of the train service employees only, we want to take care of all classes who should receive consideration, if we give to one, we will give to all who are in need of assistance." He immediately appointed a Wage Commission, and after many months of toil they recommended wage increases and such wage increases as were approved by the Director General are fair to labor in the railroad shops, on the locomotives and on the trains, and also fair to the people who are required to pay the bill. What else did Mr. McAdoo do for labor? On some of the railroads you will remember many employees had been thrown out of work and expert mechanics were denied employment by officers of these roads for various reasons. When the Government took control, Mr. McAdoo immediately issued instructions that made it possible for all of these men to resume work.

During the past four months a certain railroad discharged employees for joining a labor organization, but when such dismissal was brought to the attention of the Railroad Administration they reinstated such employees, and paid them for the time lost. On another railroad where the employees had been allowed time and one-half for Sunday work for many years, the officers decided to discontinue such allowance, but I was sent to adjust this matter and I instructed the officers that Mr. McAdoo did not approve of such reduction, so the premium overtime for Sunday work was restored. In the last six months I have handled about one hundred cases for the Government and in adjusting these matters if there has been a question of doubt I have given the benefit to those that toil. I have worked in shops, so I know your troubles, and in the months gone by I have repeatedly gone on record as favoring better conditions and increases in wages for shop crafts, and this also has been the attitude of the entire Railroad Administration, for they have followed Mr. McAdoo's policy, which is a square deal to all.

I have tried thus far in my address to show you that in the past six months Mr. McAdoo and his representatives have given a square deal to all. Now the point I want to raise is,—have you done as you ought to have done, have you reciprocated and done your part, or have you failed to do your duty, and has such failure been due to a mistake of the head, or one of the heart?

The question that brought me to this territory was to ascertain why the shop output was not measuring up to the standard it should. I find the employees are not giving the Government the output which they had given to the railroads under private control, regardless of the fact that the wages

*This is an abstract of an address to the shopmen at one of the important railway shops in the East. It was presented last August—during the war—but as it contains a message which applies to existing conditions it is printed now, having been released for publication but recently. The name of the shop at which the address was made has been eliminated by the editor as it is understood that substantially the same address was made at other shops.

have been raised and conditions improved. This is the problem that is worrying the Government: "What is the trouble?" Is it a Sinn-Feiner or an I. W. W. movement to try to prevent us from winning the war, or "are you real Americans?" Real Americans, making a mistake of the head rather than of the heart. I cannot believe you would intentionally help the Kaiser to kill our American boys. Let us stop for a moment; examine your conscience; ask yourself if you worked every day you could have worked since the war started; have you laid off and gone out for a good time, when you ought to have been at your machine turning out parts which are sorely needed; have you refused to work overtime hours; have you gone into a wash room as I saw seventeen last Saturday, reading papers and smoking, have you read newspapers during working hours; were you one of the men in the blacksmith shop who sat down and read papers in the presence of officers during working hours? Ask yourselves, "Have I given a fair day's work for a fair day's pay?"

There are some things that are going on in the shop that have got to come to a stop. I told your committee the other day that I thought the Government took over this railroad some time ago, but I found that the employees, so far as this shop was concerned, were still running it. This policy must cease, and in the future if the officers instruct you to do anything, it will be up to you to do it unless it involves bodily harm; if you think such instructions are not right, then make a grievance of the matter and handle it in the manner provided for in Order No. 8 and we will see that justice is done, but do not refuse to obey your officers, as you must obey the instructions of the officers in charge if you are to remain in Government service.

Lounging in the toilet room must cease; it is not there for that purpose. Do not use it as a play room. Another thing which must cease is the wasting of your time visiting, and the reading of newspapers while on duty in this shop. In days gone by you turned out fifty-four locomotives a month from this shop, and you are not doing it now; you did it on fifty-four hour weekly schedule, why can you not do as much in these days of trials and tribulations, as you did in time of peace? You can if you want to, and I know you will. Another question I desire to cover is starting to work promptly. When the seven o'clock whistle blows in the morning you must start work, you must be on your job and not lounge about for thirty minutes before starting to work.

We desire that all machines be kept at a speed that will insure their maximum output. I have said that insubordination must cease, men must obey orders; we want officers to be kind to the men, but we do not want them to keep men in the shops who will not help the Government. I said further to the officers, if there were men in the shop who would not work the required number of hours, that my advice would be to get rid of them; for we cannot afford to tie up machines day after day, waiting for some men who work only when they please. Men must work unless sickness prevents them from doing so. We are going to expect a sufficient amount of overtime to finish locomotives about ready to leave shop, for there is no need of holding locomotives from Saturday until Monday when, by working a few hours overtime, you can avoid it. And no man who is a real American would want to delay locomotives.

I have said to the officers, do not overdo the overtime question. Their answer was, "if the men will discontinue laying off, there will be no need of overtime." The percentage of men laying off at this locomotive shop is running as high as 20 per cent, when it should not exceed 7 per cent. We want you to work ten hours a day. We are paying the mechanics as high as \$7.50 and the helpers as high as \$5 for so doing and I do not care what anybody says, that is better wages than you ever got, or ever hoped to get. This is as true as we are standing here. (Applause).

Mr. McAdoo was mighty square when he dated your increases from January 1, thus giving you hundreds of thousands, yes, millions of dollars back pay; in so doing, he did something that no railroad ever did, or ever would do, and now he is requesting you to do one or two things for him. First, he desires faithful service; second, that you work all the time you can work, all the time your health and your family's health will permit. I have brought these things home to you in as plain language as I can in order to show you that you have a patriotic duty to perform. You are going to say to me, we are patriotic men. We have bought Liberty Bonds, given to the Red Cross and filled up the War Chest. I am going to reply to you by saying that it would have been much better for you to have kept all your money and given us faithful service, for what good is your money if you do not allow the Government to spend it; they would have to pay interest on it, and get no good out of it.

When General Pershing and his faithful boys reach home, if you have done what is right you will be able to look them in the face and say, I did not go across, but I was a real 100 per cent American Shop Soldier, and the Government told me if I was that you would come home, and you did; and then when your babies grow up and say, "Dad, what did you do in the great war?" you will be able to say, "Your dad did all the Government asked him to do, and he did his part faithfully and was a real American."

AN IMPROVED HYDRAULIC RAM

BY CHAS. W. SCHANE

The drawing shows an interesting method of obtaining hydraulic pressure by means of a Westinghouse locomotive air compressor for testing boilers or for operating hydraulic pit jacks. A cylinder made from steel tubing with a brass liner cast in it and bored to suit the piston rod of the air compressor is screwed into the pump saddle and stuffing box gland and is secured with a lock nut.

This ram, placed in a central position with respect to the

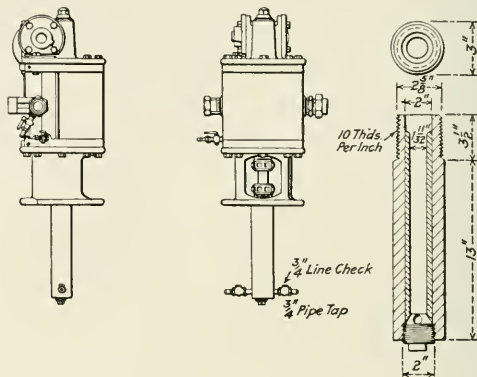

Hydraulic Ram Made from a Westinghouse Locomotive Air Compressor

drop pits, does away with hand power for operating the jacks. The pump line is so arranged that the water will flow through the check valves to the jack and raise the plunger to the work without operating the ram. A few strokes of the ram will then do the work.

When the ram is used for testing boilers it can be mounted on a suitable cart, and when it is used for operating jacks it should be mounted on a stationary stand. This device has been in service for several months and has given good results.

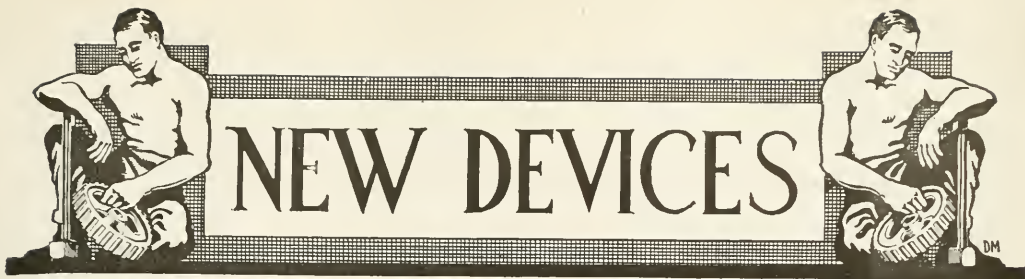

HOSE MOUNTING AND HOSE CLAMP-ING MACHINE

The hose mounting and clamping apparatus shown in the illustrations was developed several years ago for the use of the Westinghouse Air Brake Company, Pittsburgh, Pa., and it has proved to be an economical and satisfactory appliance. While this company has not heretofore attempted the manufacture of these devices except for its own needs, it has arranged so that they can be procured on order, either as complete outfits or merely such details as are not obtain-

able from existing railroad material. These can either be obtained from the company or made to blue prints which it will furnish on request.

Referring to Fig. 1 it will be observed that the hose mounting machine consists of a Z-bar frame on which is mounted a hand operated clamp, designed to grip the hose throughout the greater part of its length so as to hold it rigid while the coupling or nipple is being applied; a compressed air cylinder; an operating valve for controlling admission and exhaust of the air from the compressed air cylinder, and accessories including a reservoir, C-6 feed valve and cocks.

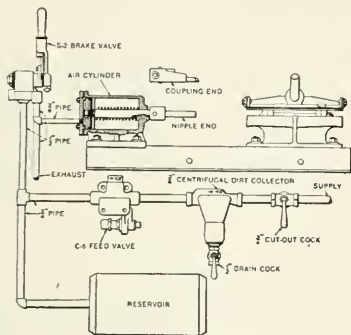

Fig. 1—Hose Mounting Machine

able from existing railroad material. These can either be obtained from the company or made to blue prints which it will furnish on request.

HOSE MOUNTING MACHINE

The piston rod of the cylinder is adapted to the special heads used for mounting the coupling or the nipple. These heads are removable so that both the nipple and coupling can be mounted on a single machine, although not at the same time.

The operation of the machine is essentially as follows: The hose is placed in the hand operated clamp. The shank end of the nipple or coupling, before being placed on the head, is dipped in rubber cement which acts as a lubricant and also serves to make an air-tight and rigid joint. The

clamp is then drawn down to hold the hose rigid; the handle of the operating valve is moved to application position admitting air to the cylinder, causing the piston and rod to move out and forcing the shank end of the nipple or the coupling into the hose. The handle of the operating valve is then moved to release position in which the air is exhausted from the cylinder and the piston and rod returned to normal position. The clamp is then released and raised, allowing the hose to be removed.

HOSE CLAMPING MACHINE

When all of the couplings have been applied to one end of the hose, the head on the cylinder piston rod is changed and the nipples applied to the other end of the hose in the same manner.

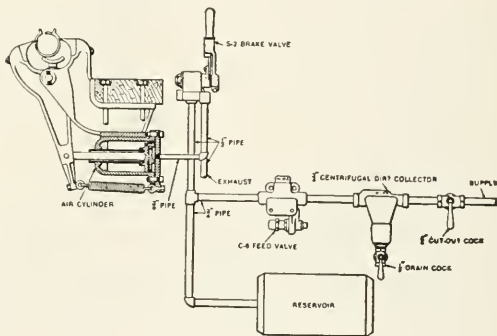

Fig. 2—Hose Clamping Machine

must properly engage the shoulders of the clamp to avoid pinching the hose), an operating valve and a feed valve, together with the usual reservoir and accessories such as cocks, etc.

After the coupling and nipple have been applied, the clamps are first loosely strung on the hose. This is readily accomplished by kinking the hose to permit of slipping on the clamp through the opening between the lugs. The hose is then laid on the support and the clamp placed in position by hand. (It is important that the clamp be between the end of the hose and the bead on the shank of the coupling

steam pipe, and a short passage leading to the center of the valve. After being admitted to the cylinder it is exhausted into the ends of the steam chest. From this point a passage leads along the side of the chest, turning downward after passing the ports and leading into the exhaust cavity at the center of the valve seat. The live steam passages in the cylinder leading from the saddle are blocked.

Excellent results were secured with this arrangement on the Consolidation locomotives. It is now planned to apply piston valve chests to a number of eight-wheel locomotives which are to be superheated. The general arrangement of the engine with piston valves is shown in the illustration. The change from an outside admission to an inside admission valve necessitates a few alterations in the valve gear. It is not feasible to bring the center line of the piston valve down to the level of the valve stem, so it is necessary to use a long crosshead to which the valve stem is attached.

When the design of this steam chest was prepared it was thought that the circuitous course the exhaust steam followed would have a tendency to increase the back pressure in the cylinders, and for that reason special care was taken to provide passages of ample cross-sectional area. Experience with the converted engines indicates that this has been successfully overcome, as there is no perceptible increase of back pressure over the locomotives of the same type fitted with slide valves. A patent on this steam chest has been granted to Mr. Clark and the manufacturing rights are controlled by the Franklin Railway Supply Company, New York.

ARC WELDING TOOL WITH POSITIVE ELECTRODE CLAMP

In metal electrode arc welding, a considerable portion of the operator's time is consumed in changing welding electrodes. A variety of welding tools have been developed and placed on the market. The oldest forms consisted of a pair of spring tongs which had to be spread apart by an instru-

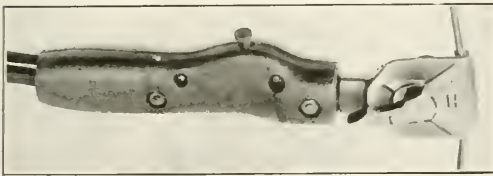

Arc Welding Tool with a Positive Clamp for Holding Metal Electrodes

ment similar to an offset screwdriver when it was desired to insert the electrode and release it. Another type employed a pair of tongs which could be operated by a thumb lever. The disadvantage of this scheme was that in case the electrode stuck to the work the operator released the tool, drawing an arc between the tongs and the electrode, a practice which soon destroyed the tongs. The type in most common use employs a strong compression spring. If this spring is strong enough to hold the electrode when it freezes to the work so that the electrode cannot be pulled away from the tool, it requires considerable strength to operate it and is therefore not always suitable where girl operators are employed.

After a study of these conditions the tool shown in the illustrations was developed and patented by the Arc Welding Machine Company, Inc., New York. The purpose was to make the operation of changing electrodes absolutely definite and to provide an instrument that would hold the electrode firmly in case it froze to the work, at the same time have it operate easily for voluntary release.

In this tool the welding current enters at the rear end of the composition shank, passes along the shank to the head of the tool, and from there directly into the electrode. It will be noted that there are no joints except where the cable is soldered into the shank. Therefore, heating due to contact resistances cannot occur. There is a relatively large contact surface between the electrode and the holding head, which insures against heating at this point. The electrode is clamped by a spiral segment operated by a lever. The lever is thrown to the widest open position to insert the electrode, and then is turned in the opposite direction

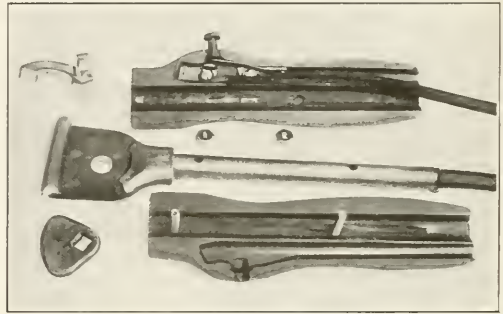

Arc Welding Tool Dissembled

as far as it will go. Any attempt to pull out the electrode, results in tightening the grip of the segment, which is made of case-hardened steel.

The trigger is intended for remote control, employed with the closed-circuit system, manufactured by the Arc Welding Machine Company, Inc. When this holder is used on other systems the trigger is omitted.

MILLING MACHINE VISE

A quick operating vise for use on milling machine tables fitted with side bars to take the clamping strain has been developed by the Edlund Machinery Company, Inc., Cortland, N. Y. The purpose of the side bars is to prevent the stationary jaw from being forced out of square under the action of the clamping strain and also to prevent the break-

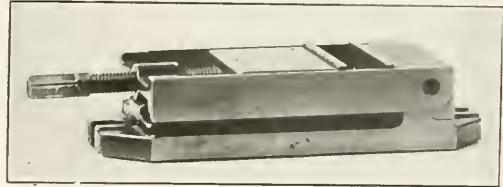

Milling Machine Vise with Side Bars

age of the base when undue strain is applied. The side bars are hinged to the stationary jaw and in operating the vise they are raised to a vertical position. In raising the bars the sliding jaw is moved away from the work by a cam arrangement. After placing the work the side bars are lowered, which automatically moves the sliding jaw up to the work, the final clamping pressure being applied by tightening the screws. This type of vise is made in four sizes weighing from 23 lb. to 95 lb., with a range of jaw opening from 2 in. to 4½ in. The width of the jaws varies by steps of one inch from 4¼ in. to 7¾ in. The jaws are hardened and ground.

Railway Mechanical Engineer

formerly the RAILWAY AGE GAZETTE, MECHANICAL EDITION
with which the AMERICAN ENGINEER was incorporated

PUBLISHED ON THE FIRST THURSDAY OF EVERY MONTH BY THE
SIMMONS BOARDMAN PUBLISHING COMPANY

EDWARD A. SIMMONS, *President* L. B. SHERMAN, *Vice-President*
HENRY LEE, *Vice-President and Treasurer* M. H. WIUM, *Secretary*
WOOLWORTH BUILDING, NEW YORK, N. Y.
F. H. THOMPSON, *Business Manager*, CHICAGO.

Chicago: Transportation Bldg. Cleveland: Citizens' Bldg.
Washington: Home Life Bldg.
London: Queen Anne's Chambers, Westminster.

ROY V. WRIGHT, *Editor*
R. E. THAYER, *Managing Editor*
C. B. PECK, *Associate Editor* A. F. STUEBING, *Associate Editor*
C. W. FOSS, *Associate Editor*

Entered at the Post Office at New York, N. Y., as mail matter of the second class.

Subscriptions payable in advance and postage free; United States, Canada and Mexico, \$2.00 a year; Foreign Countries, \$3.00 a year; Single Copy, 20 cents.

WE GUARANTEE, that of this issue 6,950 copies were printed; that of these 6,950 copies 6,042 were mailed to regular paid subscribers, 37 were provided for counter and news company sales, 184 were mailed to advertisers, 66 were mailed to employes and correspondents, and 601 were provided for new subscriptions, samples, copies lost in the mail and office use; that the total copies printed this year to date were 91,300, an average of 7,608 copies a month.

THE RAILWAY MECHANICAL ENGINEER is a member of the Associated Business Papers (A. B. P.) and the Audit Bureau of Circulations (A. B. C.)

From January 1 to October 31, 7,251 freight cars and 94 passenger cars were constructed in railroad shops.

The Russian government has recently reinstated orders for 4,000 of the freight cars it had previously ordered and later cancelled. The American Car & Foundry Company will build 2,600 and the Standard Steel Car Company 1,400.

The Committee on Car Construction of the Master Car Builders' Association has sent out Circular 19 to members, asking for suggestions for the modification of the methods outlined in Rule 22 of the interchange rules for the splicing of car sills. Recommendations are to be sent to W. F. Keisel, Jr., Pennsylvania Railroad, Altoona, Pa.

A press dispatch from Tours, France, says that during the month of October our Yankees assembled and placed in service 150 French and Belgian locomotives, 2,546 freight cars, and 1,262 American locomotives. Nearly 13,000 American freight cars were then being operated by the Service of Supply. American engineers repaired in October over 300 French locomotives and 1,000 cars.

At the suggestion of the mechanical department of the Railroad Administration, the Master Car Builders' Association has modified its Rule 3-I, which provided that after October 1, 1918, all wooden cars of less than 60,000 lb. capacity, having short draft timbers, would not be accepted in interchange. An investigation was made to determine how many cars such a rule would cut out of joint service and it was found that on the first of this month there were 58,188 such cars, of which 40,514 were box cars. The rule was modified to change the effective date to October 1, 1920.

Court Order Restrains Acceptance of Standard Cars

A temporary restraining order was issued Monday in the United States District Court, at Toledo, Ohio, against William G. McAdoo as director general of railroads, instructing the receiver of the Toledo, St. Louis & Western railroad not to accept cars, sign contracts or to do anything that would jeopardize or compromise the interests of the stockholders of the road. A hearing on the injunction was set for December 16.

The case in question is one in which the stockholders' protective committee of the Toledo, St. Louis & Western seeks to prevent Mr. McAdoo from compelling the road to accept 1,250 freight cars, which the committee asserts the road does

not now need and for which the committee declares the road would have to pay an exorbitant price.

Burning Electric Locomotive Ties Up Four-Track Line

On November 20 an electric locomotive on one of the lines running out of New York caught fire a short distance outside of the city, completely tying up a four-track railroad for about two hours. The fire was caused by a breakdown in the insulation of a 640-volt lead to one of the motors, which formed a ground and set the insulation of the cables on fire. The engine crew, which had just started the fire under the heater for the car heating system, mistook the smoke of the burning insulation for the smoke from the heater, with the result that the fire from the burning insulation and the woodwork on the locomotive gained such headway before it was observed that they were unable to control it; although it is said that had the means at hand been properly used at the inception of the fire, no serious trouble would have occurred. Local fire apparatus was called and the power was shut off from the portion of the line in the vicinity of the fire. By the time the fire apparatus had arrived the fire had developed throughout the entire locomotive and had assumed such proportions that it was impossible to get at it effectively, and it was a case of leaving the fire to burn itself out. It was surprising to those witnessing the spectacle that an electric locomotive had so much combustible material in it, as these are ordinarily considered fireproof machines.

To Assist Discharged Soldiers in Obtaining Employment

Representatives of the United States Employment Service are to be stationed in all army camps and stations in this country to assist discharged soldiers in securing suitable civilian employment, according to an arrangement made effective between the War Department and the Department of Labor. Under this arrangement, agents of individual companies will not be allowed to enter the camps to recruit labor for any particular enterprise or solicit or make contracts with discharged soldiers. All employers desiring to employ discharged men should communicate at once with the federal directors for the states in which their work is located. It is also provided that the railroad and fuel administrations, the Shipping Board and the postoffice department may send accredited representatives to the camps to furnish the camp commanders with information as to opportunities for work.

Railroad Men Handle 14-inch Guns on Railway Mountings

Lieutenant-Commander D. C. Buell, of the United States Navy, well known to railroad men as director of the Railway Educational Bureau, of Omaha, Neb., has returned from an interesting expedition to France, where he had charge of the erection and putting into service of a mobile battery of 14-inch naval guns on railway mounting. This battery was in active operation on railway lines at the front and wrought considerable destruction back of the German lines. Lieutenant-Commander Buell has been connected with the Bureau of Ordnance of the Navy since last February. He was in Washington to offer his services in connection with the fuel conservation campaign when he happened to hear that a railroad man was needed to supervise the construction and later the erection of the mounting and equipment for the big guns. Within a few hours he had enrolled in the navy as a lieutenant and he was allowed four days in which to arrange his business affairs at Omaha before reporting at the Baldwin Locomotive Works at Philadelphia. He was later promoted to lieutenant commander, in recognition of his services in expediting the work; and he was sent to France with 200 railroad men, whom he selected from among the enlisted men at the Great Lakes Naval Training Station, to mount the guns, make up the trains of cars which accompany them, and organize the forces. This work was done at the locomotive erection shop by the Nineteenth Engineers (Railway).

Recent Changes in the M. C. B. and M. M. Associations

F. McManamy, assistant director of the division of operation, U. S. R. A., in charge of the mechanical department, has been made an honorary member of both the Master Car Builders' and the Master Mechanics' associations. George Laughlin, superintendent of car department, Armour Car Lines, has been appointed a member of the arbitration committee of the M. C. B. Association. J. J. Burch, district car inspector, Norfolk & Western, has been appointed chairman of the Loading Rules Committee of the M. C. B. Association, succeeding A. Kearney, resigned, and J. E. Mehan, assistant master car builder of the Chicago, Milwaukee & St. Paul, has been appointed a member of this committee, increasing the number of members to eight. The following changes in committees have been made to fill the vacancies caused by the resignation of C. D. Young, who has entered active military service: H. E. Smith, of the division of operation, inspection and tests section, has been appointed a member of the M. C. B. Committee on Specifications and Tests for Material. B. J. Burns, superintendent of rolling stock of the Michigan Central, has been made chairman of the M. C. B. Committee on Brake Shoe and Brake Beam Equipment, and F. Waring, engineer of tests, Pennsylvania railroad, has been made a member of the committee. F. Waring has been appointed chairman of the Committee on Specifications and Tests for Materials of the M. M. Association, and J. C. Ramage, superintendent of tests on the Southern Railway, has been made a member of the committee. A. R. Ayers, superintendent of motive power, New York, Chicago & St. Louis, has been made a member of the Committee on Specifications and Recommended Practice of the M. M. Association.

The revised specifications for tank cars are now ready for delivery and prices are given in Circular No. 22. Another recent circular announces an increase in the price of Pintsch gas from \$1.10 to \$1.45 per receiver.

Pershing Car and Locomotive Orders Held Up

A despatch from Tours, France, the headquarters of the Railway Service Expeditionary Forces, announces that 43 construction projects, including a deepwater dock for 20 ships, terminals, warehouse and railroads have been cancelled, and orders for 2,000 locomotives, 61,000 freight cars and hundreds of cranes, tugs, barges and derricks have been recalled, while orders for cars and locomotives are recalled as far as the Expeditionary Forces are concerned. Only the recent order for 40,000 freight cars divided between 17 car building companies in the United States, and orders for 1,500 locomotives placed with Baldwin have been definitely cancelled as yet, as it is hoped some arrangement can be made for the disposition of the remaining outstanding orders to the French government or the French railways.

The locomotive and car orders for the forces overseas totaled 2,510 and 70,000, respectively. In the case of the locomotives, 500 were ordered in July and the Baldwin Locomotive Works left off producing United States standard locomotives to work on "Pershing" locomotives exclusively. The order was soon supplemented by 10 more for replacements and then by 500, making a total of 1,010, of which some 750 have now been delivered. The 1,500 which are cancelled were covered in two orders placed in September. Similarly as to the cars, two orders were placed in July for 10,000 and 20,000, respectively, followed by 40,000 more in September. The latter 40,000 are the ones mentioned as cancelled.

Production of Locomotives

The standard gage steam locomotive industry of the United States, operating under the direction of the War Industries Board, increased its rate of production approximately 100 per cent in the months of August, September and October, according to a statement authorized by B. M. Baruch, chairman of the War Industries Board. During the last week of October the output of the three standard gage companies was 144 locomotives. From 1910 up to August, 1918, the largest number ever turned out in a single year was 3,776, which would represent an average weekly output of 72.6 locomotives. The statement emphasizes the fact that this increase in production has been accomplished without any expenditure to increase plant facilities or enlarge the existing works, but has been made possible by a redistribution of orders and concentration by each of the plants on particular types of locomotives. What the statement calls the "Pershing" locomotive, built on standard plans designed for the United States military railways, is said to have been made the sole type of steam locomotive in use behind the American lines in France and also to have been adopted by the British and French governments as the standard type for their armies on the western front.

Normally the output of the Baldwin works has not ex-

RAILROAD CLUB MEETINGS

Club	Next Meeting	Title of Paper	Author	Secretary	Address
Canadian	Dec. 10, 1918	Trains	L. Brown	James Powell	P. O. Box 7, St. Lambert, Que.
Central	Jan 10, 1919	Discussion of Fuel Conservation		Harry D. Vought	95 Liberty St., New York.
Cincinnati				H. Boutet	101 Carew Bldg., Cincinnati, Ohio.
New England	Dec 10, 1918	Fuel Conservation	Robert Collett	W. E. Cade, Jr.	683 Atlantic Ave., Boston, Mass.
New York	Dec 20, 1918	Work of the American Railroad Men in the War Illustrated talk by Lt. Commander D. C. Buell on 14-in. Naval Guns Mounted on Railway Cars			
Pittsburgh	Dec. 27, 1918		Col. H. C. Booz	Harry D. Vought	95 Liberty St., New York.
St. Louis	Dec. 13, 1918			M. J. Heppner	102 Penn Station, Pittsburgh, Pa.
Western	Dec 16, 1918			B. W. Frauenthal	Union Station, St. Louis, Mo.
				A. F. Stuebner	750 Transportation Bldg., Chicago.

ceeded 60 locomotives a week. During the week referred to it turned out 87 steam locomotives, seven gasoline locomotives and three electric locomotives, besides making general repairs on 10 steam locomotives. The American Locomotive Company has also accomplished excellent results, for while the number of locomotives is not so great the tonnage is proportionately as large. It is stated that the government is spending this year in the construction of locomotives for use in France and on the railroads in this country approximately \$200,000,000.

MEETINGS AND CONVENTIONS

Chicago Car Foremen's Association.—At the annual meeting of the Car Foremen's Association of Chicago, held at the Morrison Hotel, Chicago, on November 11, the following officers were elected for the ensuing year: President, E. C. Chenoweth, mechanical engineer, Chicago, Rock Island & Pacific; first vice-president, M. F. Covert, Standard Car Construction Company; second vice-president, James Reed, assistant master car builder, New York Central; treasurer, F. C. Schultz, chief interchange inspector; secretary, Aaron Kline, 841 Lawlor avenue, Chicago.

Locomotive and Car Foremen Organize.—An organization which promises to be one of international scope was started in Chicago, Ill., on November 13. J. A. O'Neill, St. Louis, Mo., president of the International Association of Railway Supervising Foremen, was present and addressed the meeting. Mr. O'Neill is a mechanical engineer and had no difficulty in convincing the men in these two mechanical departments of the practicability of such an organization. A local lodge with a membership of 200 was then organized, and the officers elected. George Warlick, master painter, Chicago, Rock Island & Pacific, was elected president; Dan Hayes, foreman in the locomotive department, vice-president, and John Ebler, electrical engineer, secretary and treasurer. Meetings will be held monthly and the indications point to a large growth, as it is known that the foremen on all other lines are quite favorable to this movement. The object of the association is the promotion of harmony and good fellowship, and loyalty to their trust.

The following list gives names of secretaries, dates of next or regular meetings and places of meeting of mechanical associations:

- AIR BRAKE ASSOCIATION.**—F. M. Nellis, Room 3014, 165 Broadway, New York City.
- AMERICAN RAILROAD MASTER TINNERS' COPPERSMITHS' AND PIPEFITTERS' ASSOCIATION.**—O. E. Schlick, 485 W. Fifth St., Peru, Ind.
- AMERICAN RAILWAY MASTER MECHANICS' ASSOCIATION.**—V. R. Hawthorne, 746 Transportation Bldg., Chicago.
- AMERICAN RAILWAY TOOL FOREMEN'S ASSOCIATION.**—R. D. Fletcher, Belt Railway, Chicago.
- AMERICAN SOCIETY FOR TESTING MATERIALS.**—C. L. Warwick, University of Pennsylvania, Philadelphia, Pa.
- AMERICAN SOCIETY OF MECHANICAL ENGINEERS.**—Calvin W. Rice, 29 W. Thirty-third St., New York.
- ASSOCIATION OF RAILWAY ELECTRICAL ENGINEERS.**—Joseph A. Andreucetti, C. & N. W., Room 411, C. & N. W. Station, Chicago.
- CAR FOREMEN'S ASSOCIATION OF CHICAGO.**—Aaron Kline, 841 Lawlor Ave., Chicago. Meetings second Monday in month, except June, July and August, Hotel Morrison, Chicago.
- CHIEF INTERCHANGE CAR INSPECTORS' AND CAR FOREMEN'S ASSOCIATION.**—W. R. McMunn, New York Central, Albany, N. Y.
- INTERNATIONAL RAILROAD MASTER BLACKSMITHS' ASSOCIATION.**—A. L. Woodliff, C. H. & D., Lima, Ohio.
- INTERNATIONAL RAILWAY FUEL ASSOCIATION.**—J. G. Crawford, 542 W. Jackson Blvd., Chicago.
- INTERNATIONAL RAILWAY GENERAL FOREMEN'S ASSOCIATION.**—William Hall, 1061 W. Wabasha Ave., Winona, Minn.
- MASTER BOILERMAKERS' ASSOCIATION.**—Harry D. Vought, 95 Liberty St., New York.
- MASTER CAR BUILDERS' ASSOCIATION.**—V. R. Hawthorne, 746 Transportation Bldg., Chicago.
- MASTER CAR AND LOCOMOTIVE PAINTERS' ASSOCIATION OF U. S. AND CANADA.**—A. P. Danc, B. & M., Reading, Mass.
- NIAGARA FRONTIER CAR MEN'S ASSOCIATION.**—George A. J. Hocherbe, 623 Brisbane Bldg., Buffalo, N. Y. Meetings, third Wednesday in month, Statler Hotel, Buffalo, N. Y.
- RAILWAY STOREKEEPERS' ASSOCIATION.**—J. P. Murphy, Box C, Collinwood, Ohio.
- TRAVELING ENGINEERS' ASSOCIATION.**—W. O. Thompson, N. Y. C. R. R., Cleveland, Ohio.

PERSONAL MENTION

GENERAL

ERNEST R. BREAKER, chief engineer of the San Antonio, Uvalde & Gulf, has been appointed assistant mechanical superintendent with headquarters at North Pleasanton, Tex. He was born at Fayette, Mo., on July 5, 1886, and was educated at Washington University. He began railway work in April, 1909, as assistant engineer of construction on the San Antonio, Uvalde & Gulf, in charge of bridge work. In 1911 he was made chief engineer in charge of construction and maintenance, and in 1915 he was appointed also mechanical engineer. He was given complete charge of the mechanical and maintenance departments in January last, and when the road was placed under federal control he was appointed assistant mechanical superintendent in charge of motive power and car departments, the maintenance of way department and valuation.

R. W. BURNETT, shop superintendent of the Missouri, Kansas & Texas Railway of Texas, at Denison, Tex., has been appointed mechanical superintendent of the Missouri, Kansas & Texas and the other roads under the jurisdiction of J. S. Pyeatt as federal manager. His headquarters are at Denison.

EDWIN G. CHENOWETH, mechanical engineer in charge of car design on the Rock Island Lines, with office at Chicago, has been appointed mechanical engineer in charge of



E. G. Chenoweth

both locomotive and car design. Mr. Chenoweth was born on December 18, 1873, at Union City, Ind. He graduated from Purdue University in 1895, and entered railway service as a special apprentice with the Erie, at Huntington, Ind. After completing his apprenticeship he was employed as machinist for five years. During this time he took a post-graduate course at Purdue University and subsequently was air brake instructor and foreman of

the air brake department of the Erie at Huntington. In 1901 he went to the Pennsylvania as a draft-man at Altoona, Pa., and later was employed in a similar capacity on the Pere Marquette, the Lake Shore & Michigan Southern, and the Philadelphia & Reading. He returned to the Erie in 1906 as mechanical engineer, with headquarters at Meadville, Pa., and in July, 1912, he became connected with the Rock Island Lines as assistant superintendent of the car department. One year later Mr. Chenoweth was promoted to mechanical engineer, in charge of car design, which position he held until he was recently given charge also of locomotive design.

J. T. CARROLL, mechanical assistant to Charles H. Markham, regional director of the Allegheny region, United States Railroad Administration, has been appointed general superintendent maintenance of equipment of the Baltimore & Ohio Eastern lines, the Coal & Coke, the Wheeling Terminal, the Western Maryland, the Cumberland Valley and the Cum-

berland & Pennsylvania, with headquarters at Baltimore, Md., succeeding F. H. Clark, resigned.

H. B. GAMER has been appointed acting electrical engineer of the Union Pacific, with headquarters at Omaha, Neb., in place of G. C. Wilson, resigned.

N. B. EMLEY has been appointed fuel supervisor of power plants and shops of the Erie, with headquarters at Meadville, Pa., and will supervise the handling and economical use of fuel at all power plants and shops on the system, reporting to A. G. Trumbull, assistant to the general mechanical superintendent.

J. O. ENSOCKSON, master mechanic of the Chicago, St. Paul, Minneapolis & Omaha at Sioux City, Iowa, has been appointed superintendent of motive power and machinery with headquarters at St. Paul, Minn.

B. J. FARR, whose appointment as superintendent of the motive power and car department of the Grand Trunk Western Lines, with headquarters at Detroit, Mich., was announced in the November *Railway Mechanical Engineer*, was born at Ellenburg, N. Y., on September 8, 1876. He began railway work in 1893, as a machinist apprentice for the Central Vermont at St. Albans, Vt., and after completing an apprenticeship of five years he was made erecting shop foreman, being advanced to general foreman in 1900. In 1905 he went to the Delaware & Hudson as general foreman of the motive power and car department at Schenectady, N. Y., and the following year he became master mechanic for the United Fruit Company's lines at Port Limon, Costa Rica. From 1908 to 1914 he was employed in the engineering department of the Isthmian Canal Commission at Gatun and Cristobal. He then became connected with the Grand Trunk as general foreman on the western lines, at Battle Creek, Mich., and in 1916 was promoted to master mechanic at that point, which position he held until he received his recent appointment. He will also have jurisdiction over the Detroit & Toledo Shore Line.

GEORGE S. GOODWIN, mechanical engineer of the Rock Island Lines, has been appointed corporate engineer of equipment of the Chicago, Rock Island & Pacific, with head-

quarters at Chicago, having jurisdiction over matters relating to the maintenance of equipment department involving the corporation's interests. Mr. Goodwin was born at Corinth, Me., on November 29, 1876, and was graduated from Cornell University in 1899, with the degree of mechanical engineer. While attending college he spent his vacations in railway shop work and specialized in railway engineering during the last year. He entered the service of the

Chicago, Milwaukee & St. Paul in June, 1899, as a special apprentice at West Milwaukee, Wis., and subsequently was employed on special test work, etc., during which time he had charge of the company's dynamometer car on other roads as well as the Chicago, Milwaukee & St. Paul. In May, 1904, he entered the mechanical engineer's office of the Great Northern at St. Paul, Minn., where he was engaged in work connected with the standardization of loco-

otive and car details and also the design of new equipment. Mr. Goodwin went to the Chicago, Rock Island & Pacific in January, 1906, as chief draftsman at Chicago, and in May, 1910, he was promoted to assistant mechanical engineer at Silvis, Ill. He was appointed mechanical engineer of the Rock Island Lines, in charge of locomotive design, with headquarters at Chicago, in June, 1913, which position he held at the time he was recently made corporate engineer.

F. H. CLARK, general superintendent maintenance of equipment of the Baltimore & Ohio, with office at Baltimore, Md., has resigned.

E. L. GRIMM, mechanical valuation engineer, has been appointed mechanical engineer of the Northern Pacific, with headquarters at St. Paul, Minn., succeeding W. J. Bohan, promoted.

HARRY C. OVIATT, heretofore superintendent at Danbury, Conn., has been appointed superintendent of motive power of the New York, New Haven & Hartford, the Central New



Harry C. Oviatt

England, the New York Connecting, the Wood River Branch, the Union Freight Railroad and the Narragansett Pier Railroad, with headquarters at New Haven, Conn. Mr. Oviatt was born in Milford, Conn., on December 5, 1871, and received his education in the grammar schools. His entire railroad career has been with the New York, New Haven & Hartford, he having entered its employ as a fireman in May, 1889, later being made an engineman. In 1900

he was transferred to the mechanical department as an air brake inspector. Three years later he was appointed foreman of engines and in August, 1904, was promoted to master mechanic. He subsequently served as general inspector of the mechanical department and in May, 1913, was appointed assistant mechanical superintendent. The following September he was appointed superintendent of the Old Colony division and in November, 1914, was selected to organize and supervise the bureau of fuel economy on the same road, with the title of assistant mechanical superintendent. He subsequently served as superintendent, first of the Shore Line division and later of the New Haven division, until May, 1917, when he was appointed general superintendent of the lines west. From September, 1917, to May, 1918, he was temporarily in the employ of the International Shipbuilding Corporation, engaged in government work at Hog Island, as transportation manager, and from May, 1918, until his recent appointment, he was transportation superintendent of the New Haven.

J. E. INGLING, road foreman of engines of the Erie Railroad, with headquarters at Jersey City, N. J., has been appointed inspector of locomotive service, lines east of Salamanca, N. Y., with headquarters at 50 Church street, New York, succeeding V. C. Randolph, furloughed.

M. S. MONTGOMERY has been appointed fuel supervisor of the Northern Pacific, with headquarters at St. Paul, Minn.

G. E. MURRAY, chief electrician of the Chicago & North Western, with headquarters at Chicago, has resigned to



George S. Goodwin

Chicago, Milwaukee & St. Paul in June, 1899, as a special apprentice at West Milwaukee, Wis., and subsequently was employed on special test work, etc., during which time he had charge of the company's dynamometer car on other roads as well as the Chicago, Milwaukee & St. Paul. In May, 1904, he entered the mechanical engineer's office of the Great Northern at St. Paul, Minn., where he was engaged in work connected with the standardization of loco-

become electrical and mechanical engineer of the Grand Trunk Western Lines, with headquarters at Battle Creek, Mich.

J. E. O'BRIEN, mechanical superintendent of the Missouri Pacific, with headquarters at St. Louis, Mo., has had his jurisdiction extended over the Memphis, Dallas & Gulf.

J. E. O'HEARNE has resigned as superintendent of motive power of the Chicago & Alton.

IRVING A. PETERS, foreman of the electrical department of the Chicago & North Western at the Chicago shops, has been appointed to succeed J. E. Murray as chief electrician of the entire system under the jurisdiction of the mechanical department.

JAMES POWELL, chief draftsman of the motive power department of the Grand Trunk, has resigned under the superannuation plan, after 36 years of service, and has accepted a position as instructor of mechanical drawing at the Technical School, Montreal, Que., for the vocational training of returned soldiers, under the Canadian Government Civil Service Hospital Commission. Mr. Powell is also secretary of the Canadian Railway Club. He was succeeded as chief draftsman of the motive power department of the Grand Trunk by W. A. Booth, his former assistant.

G. C. WILSON, electrical engineer of the Union Pacific, with headquarters at Omaha, Neb., has been appointed electrical engineer of the Central of Georgia, with headquarters at Savannah, Ga.

C. D. YOUNG, superintendent of motive power of the Pennsylvania Railroad, with office at Wilmington, Del., has been commissioned a lieutenant-colonel in the Transportation Corps, Engineers.

MASTER MECHANICS AND ROAD FOREMEN OF ENGINES

R. E. BELL, division master mechanic of the Gulf, Colorado & Santa Fe at Galveston, Tex., has been appointed joint master mechanic of the Galveston Terminal Association.

W. C. BUREL has been appointed master mechanic of the Pittsburgh division of the Baltimore & Ohio, Eastern Lines, with headquarters at Glenwood, Pa., succeeding A. H. Hodges, transferred.

M. A. CARNEY, road foreman of engines of the Baltimore & Ohio at Keyser, W. Va., has been appointed trainmaster, with office at the same point.

L. C. CLAMBLITT, assistant road foreman of engines of the Baltimore & Ohio, Eastern Lines, with office at Cumberland, Md., has been appointed road foreman of engines with headquarters at Keyser, W. Va.

T. E. CULLEN has been appointed assistant master mechanic of the Erie at Briar Hill, Youngstown, Ohio, succeeding R. R. Munn, resigned.

CHARLES EMERSON has been appointed master mechanic of the Fargo division of the Northern Pacific, with office at Dilworth, Minn., in place of R. P. Blake, transferred.

O. A. GARBER, master mechanic of the Illinois Central at East St. Louis, Ill., has been transferred to Waterloo, Iowa, as master mechanic of the Minnesota and Iowa divisions, succeeding Norman Bell, resigned to enter military service.

A. H. HODGES, master mechanic of the Baltimore & Ohio, Eastern Lines, with office at Glenwood, Pittsburgh, Pa., has been appointed master mechanic at Keyser, W. Va.

J. F. KIMBELL, division foreman of the El Paso & Southwestern at Carrizozo, N. M., has been appointed master mechanic of the Western division, with headquarters at Douglas, Ariz., in place of F. P. Roesch, resigned.

J. L. RILEY, general foreman of the Chicago, St. Paul, Minneapolis & Omaha at Sioux City, Iowa, has been appointed master mechanic at Sioux City, succeeding J. O. Enockson.

MAYNARD ROBINSON, division master mechanic of the Gulf, Colorado & Santa Fe at Temple, Tex., has had his jurisdiction extended to include the old Galveston division. The Galveston and Southern divisions have been combined and will be known as the Southern division.

G. J. WENTZ has been appointed master mechanic of the Montana, Wyoming & Southern, with office at Belfry, Mont., succeeding H. R. French, resigned.

ARTHUR WILLIAMSON, road foreman of engines on the Western Maryland, with office at Hagerstown, Md., has been appointed superintendent of the Elkins division of the Western Maryland, the Cumberland Valley, and the Cumberland & Pennsylvania Railroad, with headquarters at Cumberland, Md., succeeding J. F. Chisholm, deceased.

CAR DEPARTMENT

E. N. FACKLER, formerly car inspector of the Philadelphia & Reading, has been appointed assistant chief car inspector at Reading, Pa.

CHARLES E. PEIFFER, general car supervisor of the Buffalo, Rochester & Pittsburgh, at Du Bois, Pa., is now master car builder, with headquarters at the same place.

W. J. ROBIDER, master car builder of the Central of Georgia, with office at Savannah, Ga., has been appointed general master car builder of the Canadian Pacific, with headquarters at Montreal, Que., succeeding C. W. VanBuren, deceased. Mr. Robider was born on February 15, 1869, at Savannah, Ga., and entered the service of the Central of Georgia as an apprentice in the car department in October, 1884. He subsequently served as foreman in the passenger shop and then as general foreman of the car department. In October, 1905, he was promoted to master car builder and since the government took control of the railroads in the United States, he has served as an alternate member of the Committee of Standards and Inspection. His appointment as general master car builder of the Canadian Pacific became effective on October 15.

IRVIN ZUBER, formerly a car inspector of the Philadelphia & Reading, has been appointed foreman car inspector, at Reading, Pa.

SHOP AND ENGINEHOUSE

WILLIAM S. ADDINGTON has been appointed night roundhouse foreman of the Chicago, Rock Island & Pacific at Halleyville, Okla., succeeding William La Rue.

A. J. LEWIS, general foreman of the Missouri, Kansas & Texas of Texas, has been appointed shop superintendent at Denison, Tex.

G. E. LUND has been appointed general foreman of the Erie Railroad at Hammond, Ind., succeeding C. Roth, transferred.

C. B. SMITH has been appointed general foreman of the locomotive department on the Philadelphia division of the Baltimore & Ohio, with office at Philadelphia, Pa.

HENRY E. WIENKE has been appointed machine foreman at the Huntington, Ind., shops of the Erie, succeeding Charles Clabaugh, transferred.

PURCHASING AND STOREKEEPING

R. L. IRWIN, purchasing agent of the Texas & Pacific, the St. Louis Southwestern of Texas, and other lines under the authority of Federal Manager J. L. Lancaster, with office at

Dallas, Tex., has had his jurisdiction extended to include the Dallas Terminal Railroad & Union Depot.

J. L. BENNETT, purchasing agent of the Central of Georgia, has been appointed purchasing agent also of the Wrightsville & Tennille, the Louisville & Wadley, the Sylvania Central, and the Wadley Southern, with headquarters at Savannah, Ga.

F. A. BUSHNELL, purchasing agent of the Great Northern with headquarters at St. Paul, Minn., and also a member of the Northwestern Regional Purchasing Committee, has had his jurisdiction extended over the Farmers Grain & Shipping Railroad, with headquarters at St. Paul.

CHARLES A. HOW, purchasing agent of the Missouri Pacific, the St. Louis Southwestern and the Louisiana & Arkansas, with headquarters at St. Louis, Mo., has had his jurisdiction extended over the Memphis, Dallas & Gulf, with the same headquarters.

N. P. RANDOLPH, purchasing agent of the Southern Pacific Terminal Company and the Galveston Wharf Company, with headquarters at New Orleans, La., will also have authority over all Galveston terminals.

I. SEDDON, purchasing agent of the Chicago, St. Paul, Minneapolis & Omaha, with headquarters at St. Paul, Minn., has been appointed also purchasing agent of the St. Paul Union Depot, the Minneapolis Eastern and the Minnesota Transfer, with the same headquarters.

COMMISSION APPOINTMENT

S. A. CHAMBERLAIN, senior inspector of motive power of the Interstate Commerce Commission at Chicago, has been promoted to succeed John R. Thompson as senior mechanical engineer in the central district of the Bureau of Valuation, Chicago.

JOHN A. SHIRLEY, who has been district inspector of locomotive boilers for the Interstate Commerce Commission at San Antonio, Tex., since 1911, has been nominated by the President for appointment as assistant chief inspector, succeeding Garland P. Robinson, resigned.

JOHN R. THOMPSON, senior mechanical engineer for the Interstate Commerce Commission, in the central district of the Bureau of Valuation, Chicago, in charge of mechanical and electrical branches, has resigned to take a commission as captain in the engineer corps of the army.

OBITUARY

JOHN McMANAMY, general supervisor of equipment of the mechanical department of the Railroad Administration, and a brother of Frank McManamy, assistant director, Division of Operation, died suddenly at his home at Grand Rapids, Mich., on November 13, of pneumonia.

F. W. TAYLOR, mechanical superintendent of the Missouri, Kansas & Texas of Texas, and the other lines under the jurisdiction of J. S. Pycatt as federal manager, died on November 14, at the age of 43. Mr. Taylor began his railroad career as a call boy with the Illinois Central at Water Valley, Miss., in 1892, and remained with that road in various capacities until December 31, 1914, at which time he was acting as master mechanic at Mattoon, Ill. From January 1, 1915, to January 1, 1917, he was superintendent of motive power of the International & Great Northern. On the latter date he was appointed superintendent of motive power of the Missouri, Kansas & Texas System and early in 1918 was made general manager of the Missouri, Kansas & Texas. He held this position until the government took over the railroads, when he was appointed mechanical superintendent of the lines controlled by Mr. Pycatt and he served in this capacity until the time of his death.

SUPPLY TRADE NOTES

The Grip Nut Company, Railway Exchange building, Chicago, announces its removal to 943 Peoples Gas building.

William T. Van Dorn, president of the Van Dorn Automatic Coupler Company, Chicago, died at his home in that city November 29.

William Casey, formerly manager of the Canadian Locomotive Company, Ltd., Kingston, Ont., has been appointed to the position of general manager.

J. D. Apgar, formerly with Vandyck Churchill Company, in New York territory, is now associated with the Machine Tool Engineering Company, New York City.

Leonard C. McChesney, advertising manager for the Thomas A. Edison industries for 16 years, died of heart disease November 10, at his home in Orange, N. J.

L. C. Sprague, district manager of sales of the Chicago Pneumatic Tool Company, at New York, has been appointed assistant secretary with headquarters at 52 Vanderbilt avenue in that city.

Francis Jordan, sales engineer for the George Cutter Company, of South Bend, Ind., with headquarters at Chicago, has resigned to go with the Wilson Welder & Metals Company at New York.

The Washington (D. C.) offices of the Austin Company have been moved to 1406 G street, N. W. C. F. Chard, formerly of the Philadelphia office of this company, will be in charge of this office.

E. C. Carroll, sales representative of the National Carbon Company, with headquarters at Chicago, has resigned to enter the production department of the Globe Seamless Steel Tubes Company at Milwaukee, Wis., effective November 1.

Major E. Tyden, vice-president of the International Seal & Lock Company, Chicago, has been promoted to lieutenant-colonel in the Division of Ordnance. Colonel Tyden is located at Rock Island, Ill., as production manager of the Rock Island arsenal.

The Walter A. Zelnicker Supply Company, St. Louis, Mo., announces the appointment of Joseph Meyerson as secretary to the president. Mr. Meyerson was associated for 10 years with the Southwestern Tariff Bureau, latterly as secretary to F. A. Leland.

The Q and C Company of Canada, Limited, has been incorporated with Charles F. Quincy, president, and Frank F. Kister, secretary and treasurer. This company will manufacture and sell in Canada railway devices controlled by the Q and C Company.

The Hall-Scott Motor Company will build an addition to its machine shop at Berkeley, Cal., which will be of concrete construction and will cost about \$40,000. Upon the completion of this building the company will have a total area of 31,250 sq. ft. for shop use.

H. D. Megary, assistant to the president of the Chicago Pneumatic Tool Company, with headquarters at Chicago, has been elected secretary, with the same headquarters, succeeding W. B. Seelig, resigned. Mr. Megary will continue to act as assistant to the president.

J. Weinland, district manager of the Liberty Steel Products Company at Chicago, has been appointed assistant to the president of that company and the Davis Brake Beam Company, with headquarters at New York. S. W. Midgley, in

charge of the railroad department of the Liberty Steel Products Company, with office at Chicago, succeeded Mr. Weindland as district manager.

In order to have a name more descriptive of the products it manufactures, the Cleveland Galvanizing Works Company, with general offices and plant at Cleveland, Ohio, will be known in the future as the Chain Products Company. The company, under its old name, has been in business since 1886.

C. B. Matthai, an attorney for the Union Pacific corporate organization, has been elected secretary of the McKean Motor Car Company, of Omaha, Neb. He succeeds C. W. Y. Loucks, who resigned recently as secretary and sales manager to enter the officers' training camp at Plattsburg, N. Y.

At a special meeting of the board of directors of the Independent Pneumatic Tool Company held in Chicago, October 30, Roger C. Sullivan was appointed a director and elected chairman of the board and a member of the executive committee, to fill vacancies caused by the death of the late John P. Hopkins.

At a meeting of the board of directors of Fairbanks, Morse & Co., at Chicago, November 13, R. H. Morse was elected vice-president in general charge of purchasing and traffic, and will also continue as a director; C. W. Pank, general director of sales, was elected vice-president in charge of sales of all factory products; W. S. Hovey, general manager of the plant in Beloit, Wis., was elected vice-president in charge of general manufacturing at all factories; W. E. Miller, first vice-president, was elected vice-president and treasurer, and F. M. Boughey, retired as treasurer to become secretary and controller; all with headquarters at Chicago.

Charles G. Du Bois has been elected vice-president of the Western Electric Company, Inc. Mr. Du Bois entered the employ of the company in 1891 at its New York office, and occupied successively the positions of chief clerk, secretary and supervisor of branch houses. In 1907 he became comptroller of the American Telephone & Telegraph Company and in this capacity inaugurated and supervised a comprehensive system of accounting for the Bell telephone system. During the winter of 1917-1918, Mr. Du Bois was in Washington as comptroller of the American Red Cross, which position he still retains. Mr. Du Bois is 48 years of age and graduated from Dartmouth College in 1891. He is a director of the Western Electric Company, Inc., and other corporations.

Latin-American Demand for American Steel

Latin-American concerns wishing to specify American structural steel for building and railway purposes can now do so without difficulty by referring to pamphlets in Spanish and English, just issued by the Bureau of Foreign and Domestic Commerce, Department of Commerce. These pamphlets are intended to facilitate sales of such materials in Latin countries, and are published in response to numerous requests from those countries.

The five pamphlets announced are, "Standard Specifications for Structural Steel for Buildings," Industrial Standards No. 8; "Standard Specifications for Structural Steel for Locomotives," Industrial Standards No. 9; "Standard Specifications for Carbon Steel Bars for Railway Springs," Industrial Standards No. 10; "Standard Specifications for Quenched and Tempered Carbon-Steel Axles, Shafts, and Other Forgings for Locomotives and Cars," Industrial Standards No. 12; and "Standard Specifications for Carbon Steel Forgings for Locomotives," Industrial Standards No. 13. These can be purchased at five cents a copy from the Superintendent of Documents, Government Printing Office, Washington, D. C., or from any of the district or co-operative offices of the Bureau of Foreign and Domestic Commerce.

CATALOGUES

FLANGE OILERS.—The Detroit Lubricator Company, Detroit, Mich., has issued catalogue F-6, illustrating and describing the Detroit automatic flange oiler.

LOCOMOTIVE LUBRICATORS.—The Detroit Lubricator Company, Detroit, Mich., has published a 62-page catalogue covering the Detroit Bullseye locomotive lubricators and other locomotive specialties manufactured by this company.

GUN IRON.—Why Railroads Use Hunt-Spiller Gun Iron, is the title of an eight-page booklet published by the Hunt-Spiller Manufacturing Corporation, South Boston, Mass. It contains a brief discussion of the merits of gun iron which led to recognition of its value in locomotive construction by the railroads several years ago.

PORTABLE CRANES AND HOISTS.—The complete line of portable floor cranes and hoists manufactured by the Canton Foundry & Machine Company, Canton, Ohio, is listed in a 34-page catalogue issued by that company. The construction and operation of the cranes is described in detail and each type is illustrated and the principal dimensions given.

HEAT INSULATION.—Nonpareil high-pressure blocks and cement for heat insulation is the subject of a 20-page catalogue published by the Armstrong Cork & Insulation Company, Pittsburgh, Pa. This material is used for insulating boilers, ovens, feedwater heaters, tanks, etc., and various installations in which Nonpareil blocks or cement were used are illustrated in the catalogue.

COAL GATES.—Catalogue No. 37 of the Beaumont Manufacturing Company, Philadelphia, Pa., illustrates and describes the Beaumont standard types of gates for controlling the flow of coal, ashes, coke, etc., from bins and pockets. The purpose of the catalogue is to present the results of the company's experience in designing and installing gates for varied purposes and the types illustrated in the catalogue have been adopted as standard.

INSULATING BRICK.—The Armstrong Cork & Insulation Company, Pittsburgh, Pa., has published a four-page leaflet which describes the composition of Nonpareil insulating brick for furnaces and ovens, and cites an instance in support of a claim that Nonpareil insulating brick will save from 60 to 75 per cent of the heat ordinarily lost by conduction and radiation and makes it possible to attain a desired temperature in less time than would otherwise be required.

ELECTRICAL MEASURING INSTRUMENTS.—The Potentiometer System of Pyrometry and Temperature Control is the title of a 60-page catalogue published by the Leeds & Northrup Company, Philadelphia, Pa., to describe its system of pyrometry and temperature control, in which the potentiometer method is employed for measuring the electromotive force of thermocouples. The catalogue contains many illustrations, and other electrical measuring instruments manufactured by the Leeds & Northrup Company are also described.

SUPERHEATER UNIT MAINTENANCE.—This is the title of an eight-page pamphlet issued by the Locomotive Superheater Company, New York, describing the principles pertaining to the care and operation of the locomotive which prevent the necessity of repairs to the superheater units. Some of the matters dealt with are the necessity for clean flues, the effects of high water, the maintenance of the damper and the ball ends, etc. The pamphlet is illustrated with a number of sketches and photographs of tools that are especially adapted to the work of repairing and maintaining superheater units.

CARNEGIE LIBRARY OF PITTSBURGH



3 1812 04296 1210

