

LB

1599

W6N4

UC-NRLF

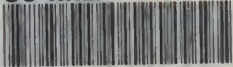

5C 12 590

WOODWORK

COURSE

FOR BOYS.

BY

WILLIAM NELSON,

ORGANISER OF MANUAL INSTRUCTION TO THE MANCHESTER SCHOOL BOARD.



LONDON

GEORGE PHILIP & SON, 32, FLEET STREET E.C.
LIVERPOOL 45 TO 51 SOUTH CASTLE STREET.

YL 00462 0

LIBRARY
OF THE
UNIVERSITY OF CALIFORNIA.

Received. *Dec.*, 1893

Accessions No. *53789* . Class No. *572*

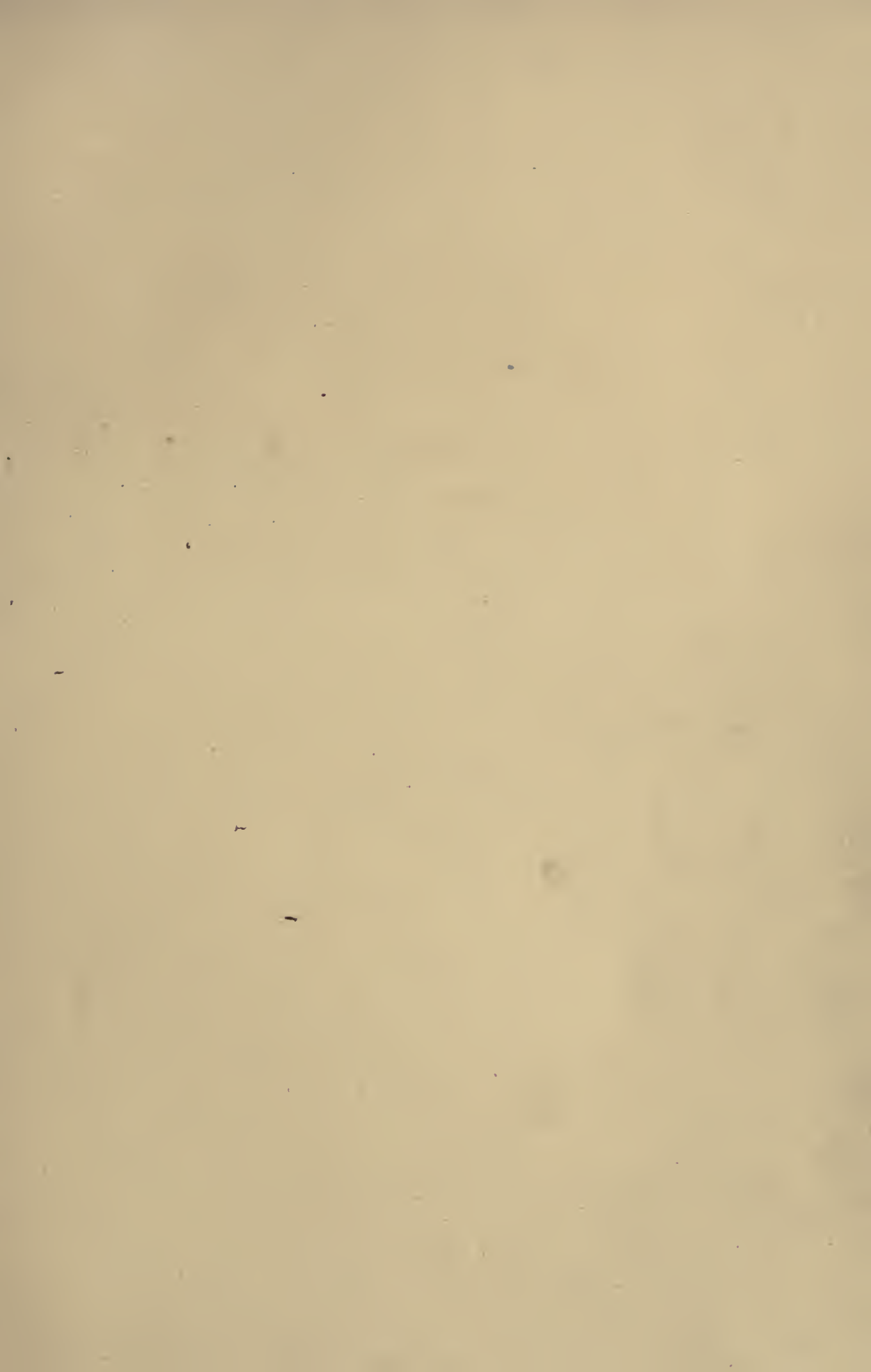



Digitized by the Internet Archive
in 2007 with funding from
Microsoft Corporation

WOODWORK COURSE FOR BOYS,

CONSISTING OF

A GRADUATED SERIES OF THIRTY MODELS,

ARRANGED SO AS TO COVER THE REQUIREMENTS OF THE SCIENCE
AND ART DEPARTMENT, SOUTH KENSINGTON.

*Containing full Working Drawings, and practical Directions for
Making each Model.*



WILLIAM NELSON,

ORGANISER OF MANUAL INSTRUCTION TO THE MANCHESTER SCHOOL BOARD.



LONDON:

GEORGE PHILIP & SON, 32 FLEET STREET, E.C.

LIVERPOOL: 45 TO 51 SOUTH CASTLE STREET.

1893.

All Rights Reserved.]

[*Entered at Stationers' Hall.*

L 131599
W 6N4

P R E F A C E.

This series of models was arranged primarily for use in the schools where the manual instruction was under my own supervision. It has been tested, and found to be a workable course.

The exercises involved are those found in English Carpentry.

Models 5, 6, 11, 13, 20, 26, and 28, are exercises that are not embodied in complete objects. They are good specimens of work that has actually been set at the wood-working examinations, held by the Science and Art Department in Elementary Schools.

The other twenty-three models are embodiments, in complete and useful objects, of these and other exercises in Carpentry.

The principle followed in arranging the series has been to proceed as logically as possible from easy to more difficult work.

In schools where the course has been worked, the method of instruction has been to first exhibit the object to be made to the class, then to draw several views of it to large scale on the blackboard, from which the boys make drawings to scale in their own books. Then the teacher has given a practical working demonstration of the model, and described the wood and tools used, the class taking notes. In the workshop the instruction has been individual, and the boys have worked from their own drawings, and not from models.

53789

It will be noticed that the sizes for the rough wood for each model are given along with the practical directions. The boys are not allowed to cut out their own timber from the board, as this entails unnecessary waste of wood, and takes up too much of the teacher's time in superintendence. On this account, care has been taken to provide a sufficient amount of sawing exercise in the working of the models. The timber should be ordered cut up to the sizes required. There is also an economical advantage in buying short lengths.

Some of the models in this course are taken from the Nääs series, arranged by Herr Otto Salomon, whose general principles have also been followed.

Manchester, Jan. 1893.

W. N.

CONTENTS.

No.	NAME.	WOOD.	DIMENSIONS.
1	Wedge.	Yellow Pine.	2 in. by $\frac{3}{4}$ in. by $\frac{1}{2}$ in.
2	Plant Label.	" "	$4\frac{1}{2}$ in. by 1 in. by $\frac{1}{4}$ in.
3	File Handle.	" "	4 in. by 1 in. by $\frac{3}{4}$ in.
4	Winder.	Baywood.	4 in. by $1\frac{3}{4}$ in. by $\frac{1}{4}$ in.
5	Sawing Exercise.	Yellow Pine.	6 in. by $1\frac{1}{4}$ in.
6	Tee Joint (halved).	" "	5 in. by $1\frac{1}{4}$ in. by $\frac{3}{4}$ in.
7	Round Ruler.	Cedar.	12 in. by 1 in.
8	Dish Rest.	Yellow Pine.	6 in. by $1\frac{1}{4}$ in. by $\frac{3}{4}$ in.
9	Pan Stand.	" "	5 in. by 1 in.
10	Bench Hook.	Basswood.	11 in. by $2\frac{1}{2}$ in. by $1\frac{1}{4}$ in.
11	Mortise Joint.	Yellow Pine.	5 in. by $1\frac{1}{4}$ in. by $\frac{3}{4}$ in.
12	Pen Tray.	Basswood.	10 in. by $2\frac{3}{4}$ in. by 1 in.
13	Dovetail Joint.	Yellow Pine.	5 in. by $1\frac{1}{4}$ in. by $\frac{3}{4}$ in.
14	Flower Pot Stand.	" "	16 in. by $4\frac{1}{2}$ in.
15	Sieve Rest.	Basswood.	15 in. by $5\frac{3}{4}$ in.
16	Scoop.	Sycamore.	$9\frac{3}{8}$ in. by $2\frac{3}{4}$ in.
17	Flat Ruler.	Baywood.	18 in. by $1\frac{3}{4}$ in.
18	Triangular Stand.	Yellow Pine.	8 in. by $1\frac{1}{4}$ in.
19	Clothes Rack.	" "	16 in. by 3 in.
20	Box Dovetail.	" "	4 in. by 3 in. by $\frac{1}{2}$ in.
21	Towel Roller.	Basswood.	17 in. by $1\frac{7}{8}$ in.
22	Soap Box.	Yellow Pine.	6 in. by 4 in. by $2\frac{3}{8}$ in.
23	Book Carrier.	Pine and Birch.	9 in. by 6 in.
23a	" "	" "	" "
24	Knife Box.	Yellow Pine.	$11\frac{3}{4}$ in. by 7 in.
24a	" "	" "	" "
25	Axe Handle.	Ash.	19 in. by $2\frac{5}{8}$ in.
26	Oblique Dovetail.	Yellow Pine.	5 in. by 2 in. by $\frac{3}{8}$ in.
27	Set Square.	Birch.	8 in. by $4\frac{5}{8}$ in.
28	Shouldered Dovetail.	Yellow Pine.	5 in. by 2 in. by $\frac{3}{4}$ in.
29	Tee Square.	Baywood.	18 in. by $1\frac{3}{4}$ in.
30	Tea-Tray.	Yellow Pine.	$13\frac{1}{2}$ in. by $9\frac{3}{4}$ in.

The complete Set of 30 Models, as above, may be had, well made and finished,
Price £2 10s.

No. 1.—W E D G E.

Rough Wood—Yellow Pine—4 in. × 1 in. × $\frac{3}{4}$ in.

TOOLS.—Knife and file.

- (1). Cut one side straight and flat, testing with the try square (using outer edge of blade lengthways and crossways).
- (2). Then cut an adjacent edge at right angles to the first side, testing with inside angle of square, and mark these two faces with the pencil to show that they have been made "true."*
- (3). Set out width with rule and pencil, and cut off.
- (4). Set out thickness and cut off.
- (5). Fix in bench vice, and file up with flat file to a more even surface.
- (6). Set out the wedge with square and rule on one end of block (tapering to the end).
- (7). Cut to shape with the knife and file over.
- (8). Now cut off the extra wood which has been used as a handle, and square up the thick end of wedge with the knife.
- (9). Cut off the corners as shown in the drawing, and finish the flat faces with sand-paper.

* These marks are called the face and edge marks, and should always be put on the first side and edge "trued up."

No. 2.—P L A N T L A B E L.

Rough Wood—Yellow Pine— $5\frac{1}{2}$ in. × $1\frac{1}{2}$ in. × $\frac{5}{8}$ in.

TOOLS.—Smoothing plane, gauge, square, knife, file, compass.

- (1). Plane up one side and one edge at right angles, and mark with face and edge marks.
- (2). Gauge to width and plane off.
- (3). Gauge to thickness and plane off.
- (4). Set out shape with square compass and rule, keeping curved end near to one end of the piece of wood.
- (5). Cut the convex end with the knife, and finish with file and sand-paper.
- (6). Cut the tapered end with the knife, but do not touch with the file.
- (7). Finish by smoothing off the sides and edges with the smoothing plane, testing measurements with the rule.

WOODWORK COURSE FOR BOYS.

No. 1. WEDGE—Pine. (Twice full size.)

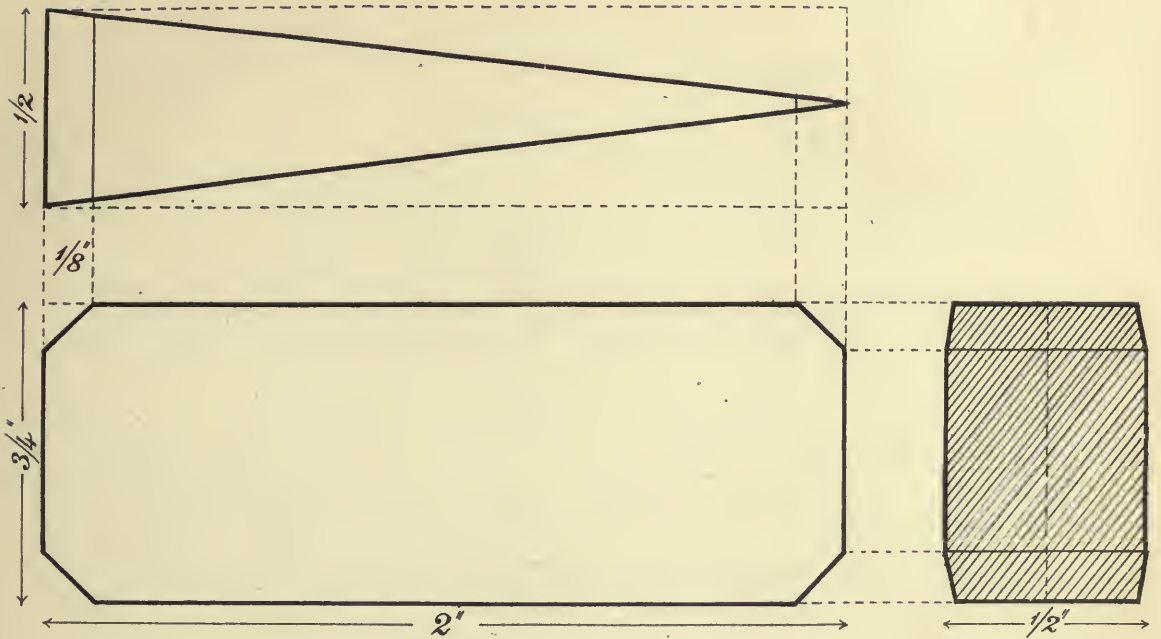

No. 2. PLANT LABEL—Pine. (Full size.)

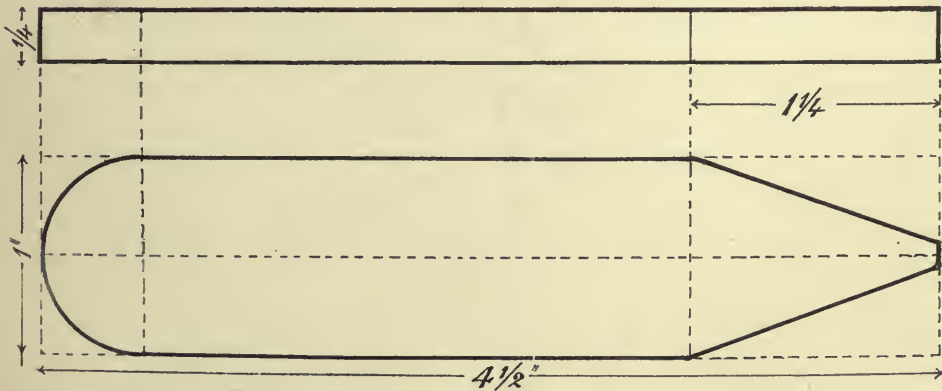

No. 3.—FILE HANDLE.

Rough Wood—Yellow Pine—5 in. × 1½ in. Square.

TOOLS.—Smoothing plane, square, gauge, gimlet, file, and knife.

- (1). Plane up.*
- (2). Square one end with knife and file.
- (3). Set out length, running the pencil marks all round the block with the square.
- (4). Cut to length, and square up the end.
- (5). Draw diagonals across one end to obtain centre for boring.
- (6). Bore the file hole 1 inch deep with the gimlet, holding block in left hand, and testing boring with the eye by watching inclination.
- (7). Set out for taper by gauging $\frac{1}{8}$ -inch around bored end, and running lines from the gauge marks to the corners of the top of the block.
- (8). Plane off the tapers.
- (9). Gauge for bevelling $\frac{1}{8}$ -inch.
- (10). Bevel sides with plane and top edges with knife, and finish.

***Note.**—The technical term “plane up,” means plane side and edge, and width and thickness; *e.g.*, plane up completely.

No. 4.—WINDER.

Rough Wood—Baywood—5 in. × 2½ in. × ½ in.

TOOLS.—Jack plane, smoothing plane, bow-saw, gauge, square, brace and centre-bit, spokeshave, file, knife, compass.

- (1). Plane a side and edge at right angles.
- (2). Then, before gauging to thickness, set out, gauging in the first place a line up the centre of the planed side, and constructing the shape of the winder on each side of this line.
- (3). Bore holes through the wood at each inside corner, where the quarter circles are shown on the diagram, with a $\frac{3}{8}$ -in. centre-bit.
- (4). Then, before sawing to shape, gauge to thickness, and plane off.
- (5). Saw to shape with small fine bow-saw, working from right to left.
- (6). Spokeshave the convex ends.
- (7). Pare the flat parts between the borings with the knife.
- (8). File and sandpaper the edges all round, keeping them square and sharp.
- (9). Finish the flat sides with smoothing plane.

Note.—The boring is done before the wood is “thickened,” in order that any roughness made by the centre-bit on coming through may be planed off.



WOODWORK COURSE FOR BOYS.

No. 3. FILE HANDLE. (Full size.)

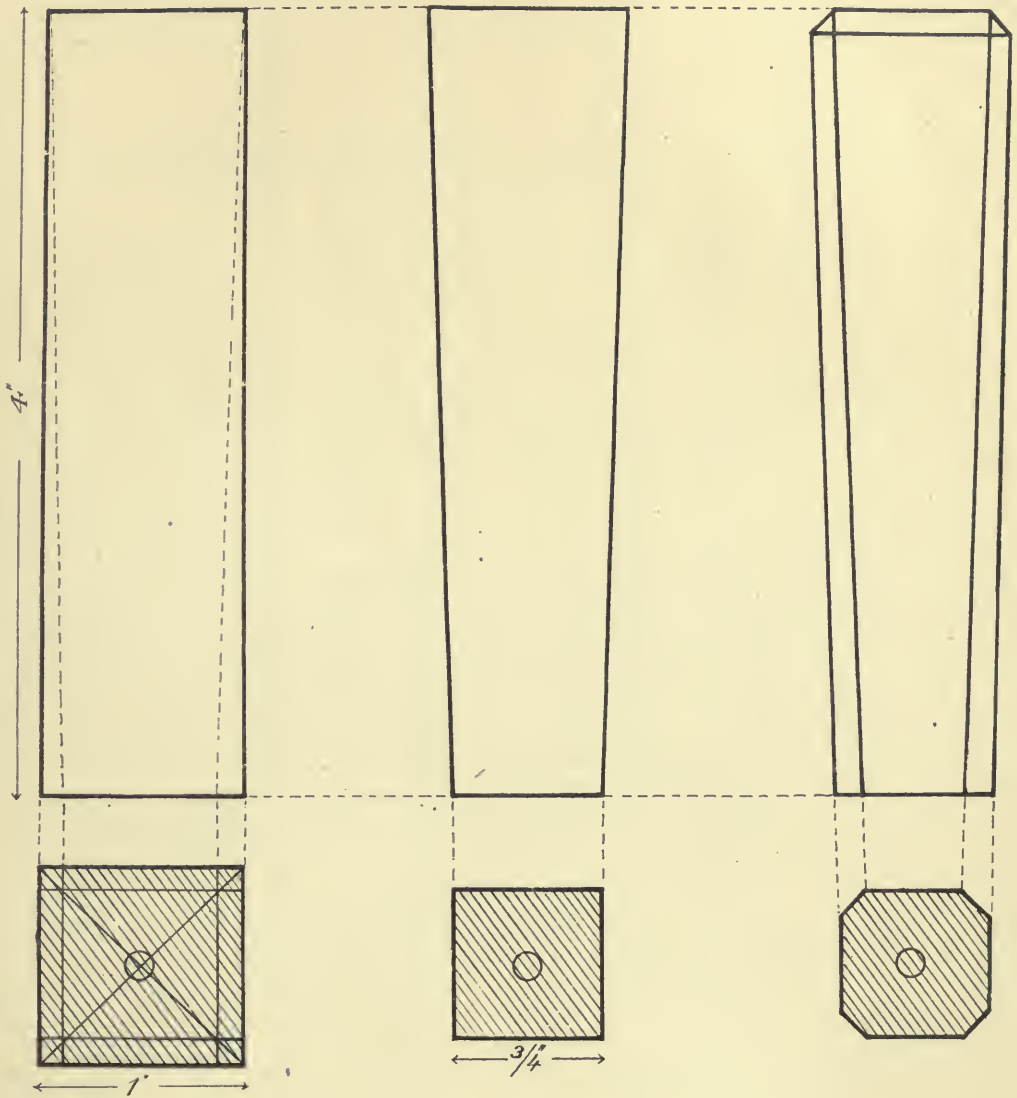

No. 4. WINDER. (Full size.)

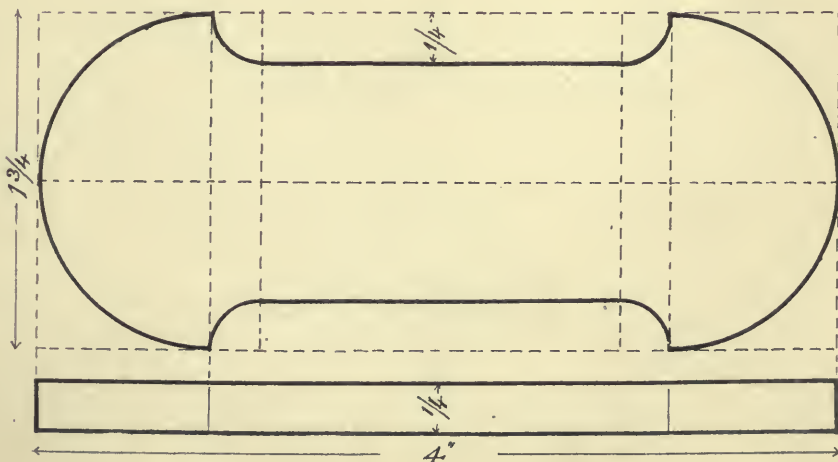

No. 3.—SAWING EXERCISE.

Rough Wood—Yellow Pine.—7 in. × 1½ in. square.

TOOLS.—Jack plane, smoothing plane, square, gauge, set bevel at 45°, tenon-saw, chisels.

- (1). Plane up to 1¼-in. square.
- (2). With paring chisel and file, square one end.
- (3). Set out length and square over with try square.
- (4). Saw to length, allowing ⅛-in. for paring off and filing.
- (5). Set out for sawing and paring, ends first, with gauge and square, then the side grooved at right angles, gauging depth of groove. With the set level set out the oblique groove and gauge the depth.
- (6). Saw the cuts across the fibre first, then saw down the ends, always keeping the saw kerf* in the waste pieces.
- (7). Pare out the grooves.
- (8). Finish with smoothing plane.

* The saw kerf is the slit made by the saw. It should always come in the waste piece, *e.g.*, it should be on the outside of a tenon and on the inside of a groove.

WOODWORK COURSE FOR BOYS.

No. 5. SAWING EXERCISE (Full size.)

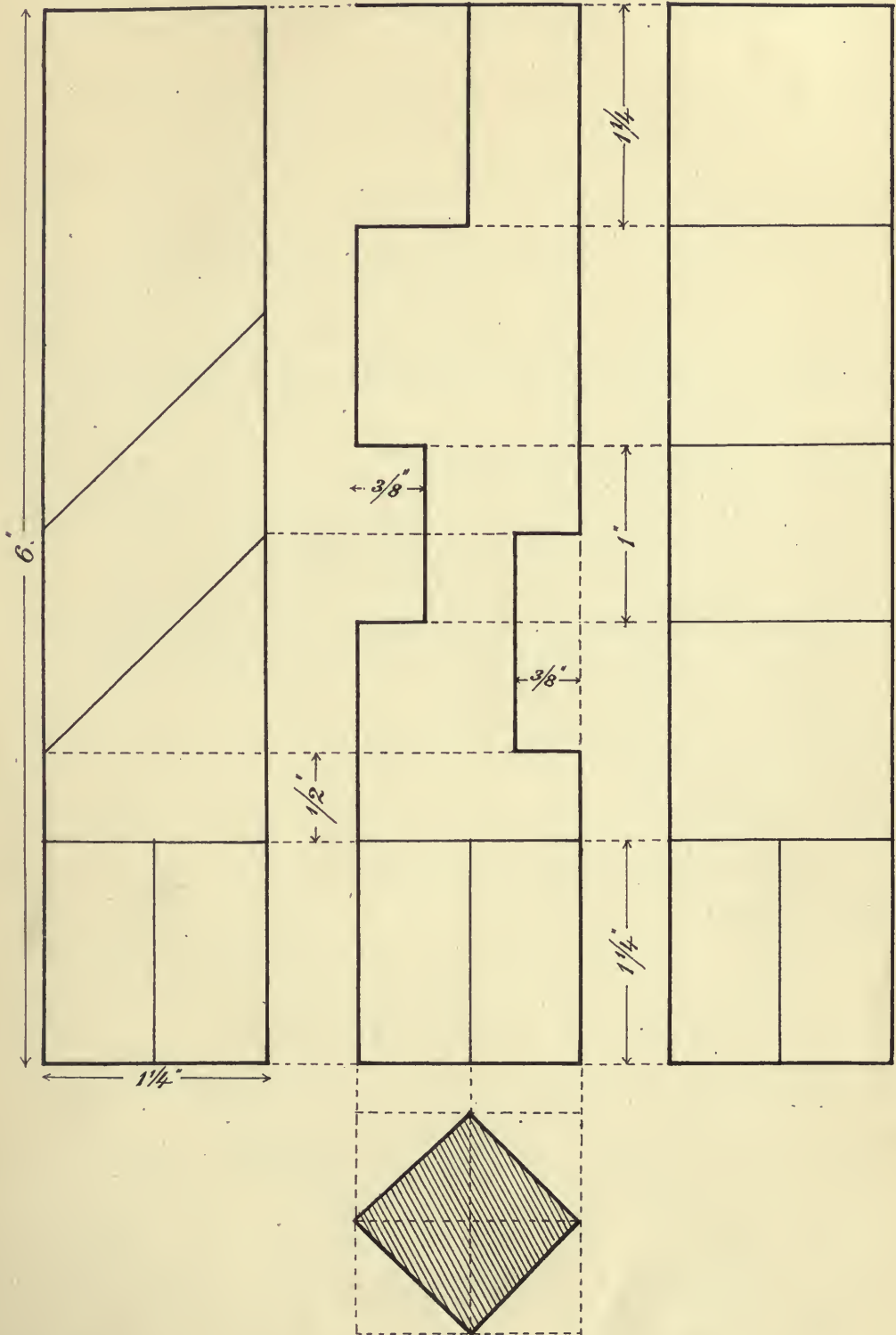

N o. 6.—T E E J O I N T.

Rough Wood—Yellow Pine.—11 *in.* × 1½ *in.* × 1 *in.*

TOOLS.—Jack plane and smoothing plane, square, gauge, compass, paring chisel, tenon-saw.

- (1). Plane up, in one piece, to right size.
- (2). Cut in half with tenon-saw.
- (3). Set out the tenon with square and gauge, and saw out.
- (4). Lay the tenon on the piece to be grooved, and mark out the width of groove, then square the marks over, and set out depth of groove with the gauge.
- (5). Cut out the groove with the saw and chisel.
- (6). Fit together.
- (7). Saw to right length and pare the ends.
- (8). Smooth off.

WOODWORK COURSE FOR BOYS.

No. 6. TEE JOINT (Halved). ($\frac{3}{4}$ full size.)

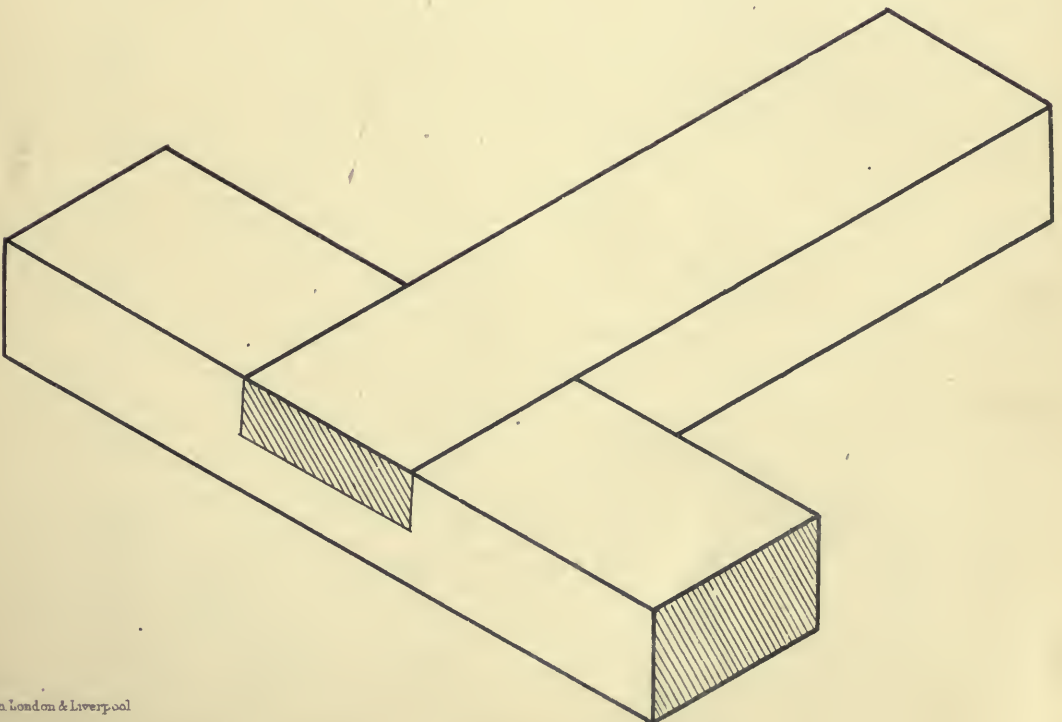
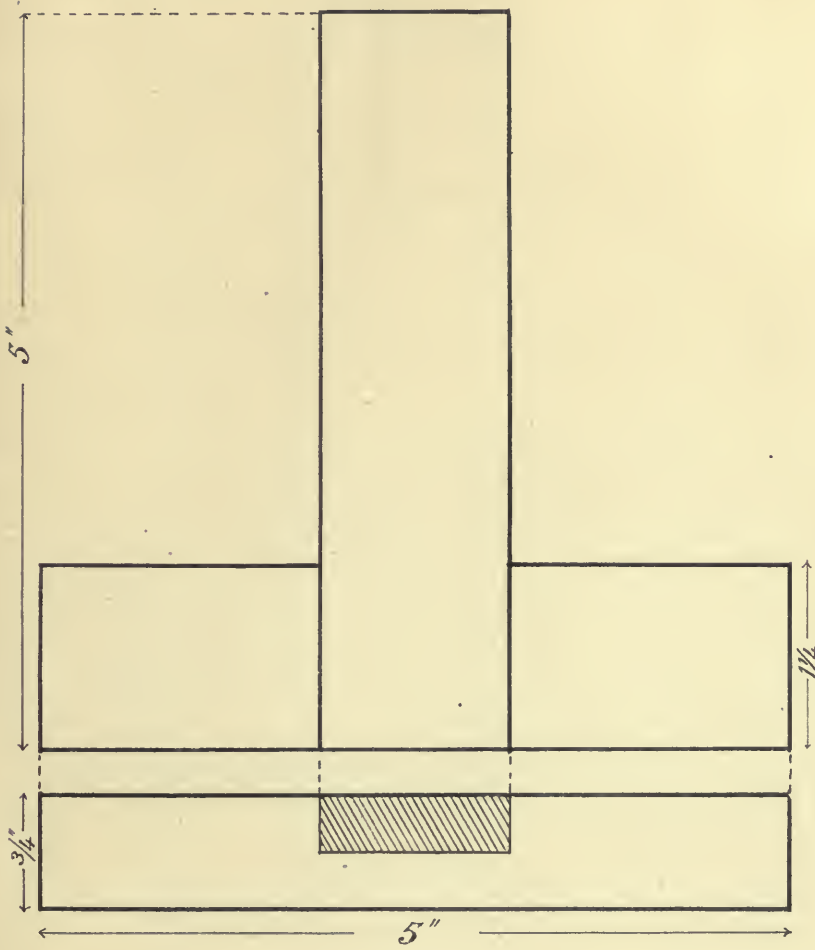

NO. 7.—ROUND RULER.

Rough Wood—Cedar— $12\frac{1}{2}$ in. \times $1\frac{1}{2}$ in. square.

TOOLS.—Jack plane, smoothing plane, square, gauge, file, knife.

- (1). Plane up, allowing $\frac{1}{16}$ -inch for rounding.
- (2). Set out octagon on each end, and gauge lines along the block as shown in the middle drawing of the diagram.
- (3). Plane off the corners, making an octagonal prism.
- (4). Again plane off the corners, making a sixteen-sided figure.
- (5). Round up with smoothing plane.
- (6). Square one end, and set out length.
- (7). Cut to length, and square the end.
- (8). Finish with file, and sandpaper.

WOODWORK COURSE FOR BOYS.

No. 7. ROUND RULER. (Full size, broken.)

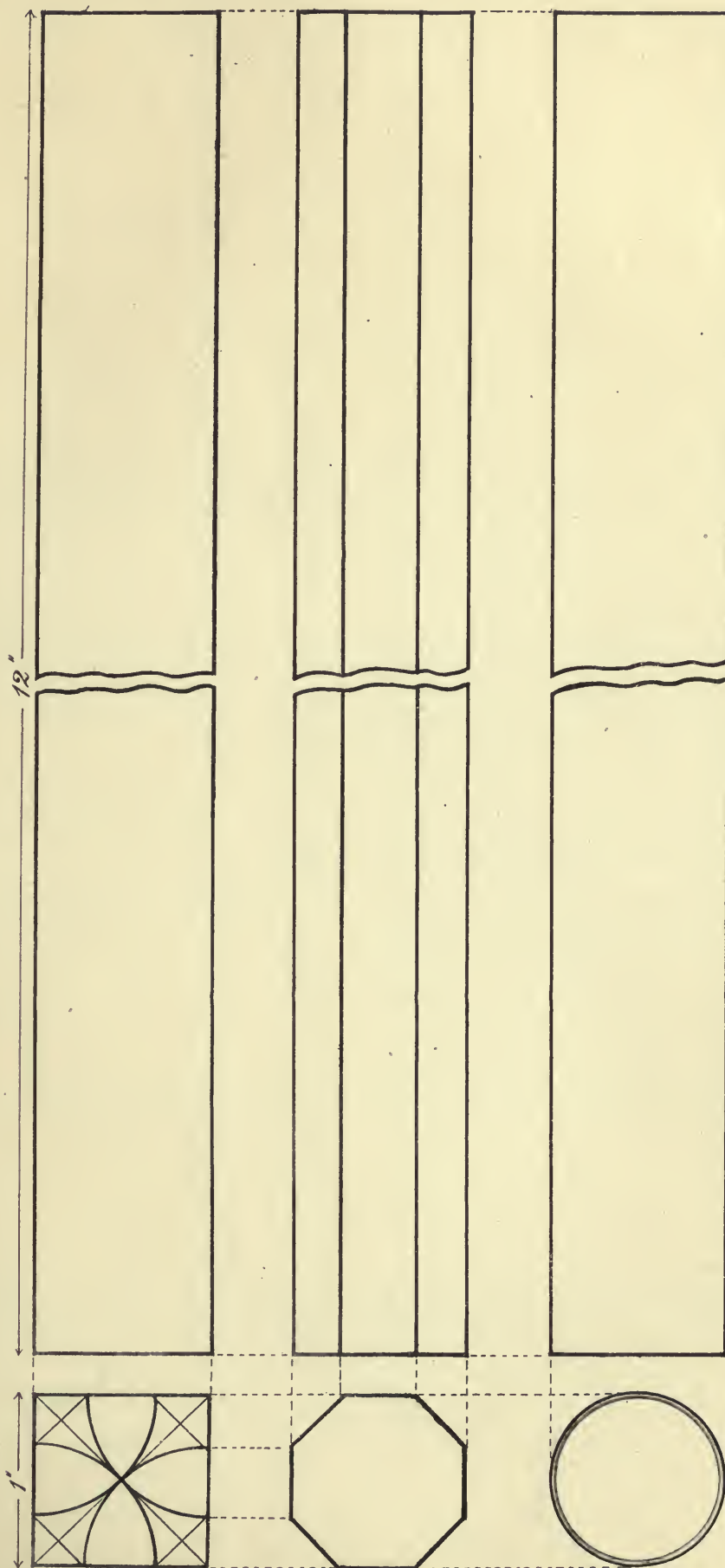

N o. 8.—DISH REST.

Rough Wood—Yellow Pine—13 in. × 1½ in. × 1 in.

TOOLS.—Jack plane, smoothing plane, square, gauge, compass, chisel, bow-saw, spokeshave, file, bradawl, screwdriver, countersink.

- (1). Plane up in one piece.
- (2). Cut in half.
- (3). Place the two pieces together, and set out for halving, with square, compass, and gauge.
- (4). Halve with tenon-saw and firmer chisel.
- (5). Fit together.
- (6). Set out the length and the curved ends.
- (7). Saw out the ends with the bow-saw, and round up with spokeshave, finishing with sandpaper.
- (8). Set out, and bore for screwing together.
- (9). Screw together and smooth off.

Note.—Use a ½-inch screw, and sink the head with the countersink bit.



WOODWORK COURSE FOR BOYS.

No. 8. DISH REST (Halved). (Full size.)

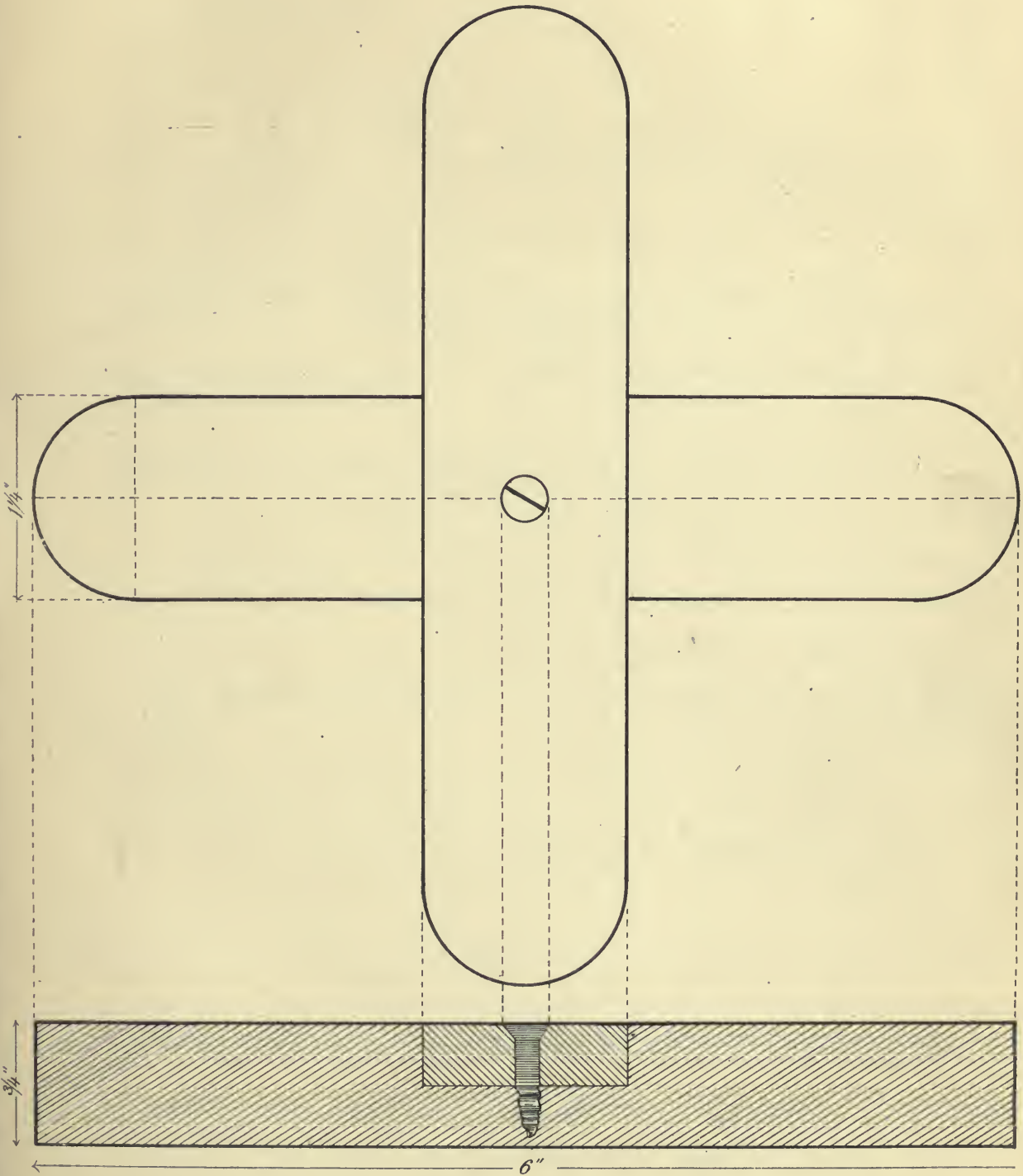

N o. 9.—P A N S T A N D.

Rough Wood—Yellow Pine—12 *in.* × 1½ *in.* × ⅝ *in.*

TOOLS.—Jack plane, smoothing plane, square, gauge, compass, tenon-saw, dovetail-saw, firmer chisel, knife, file.

- (1). Plane up in one piece.
- (2). Cut in half with saw.
- (3). Set out the feet with square and gauge, and cut out with the saw and knife, using the file to finish with.
- (4). Set out for halving, with square and gauge.
- (5). Halve with the dovetail-saw and ¼-inch firmer chisel.
- (6). Square the ends with chisel and file.
- (7). Set out the curved corners, and round with knife and file.
- (8). Smooth off, and fit together.

Note.—In setting out the part cut away for the feet, take the centre of the piece of wood and set off 1¾ inches on each side, leaving the final length of feet to be finished at step “6.”

WOODWORK COURSE FOR BOYS.

No. 9. PAN STAND. (Full size.)

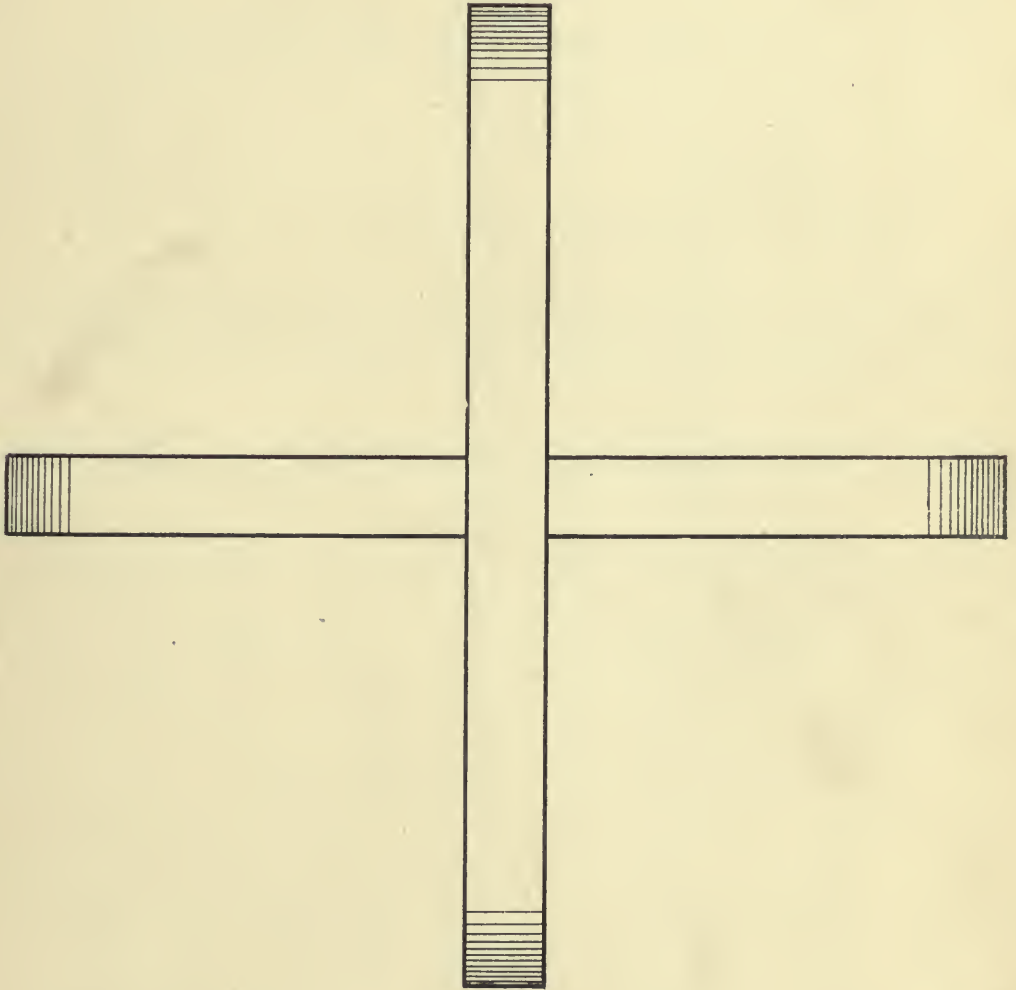
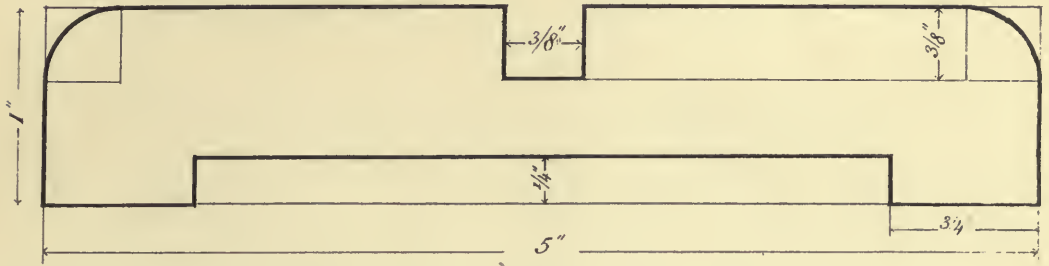

No. 10.—BENCH HOOK.

Rough Wood—Basswood.—12 in. x 3 in. x 1½ in.

TOOLS.—Jack plane and smoothing plane, square, compass, brace and centre-bit, rebate plane, gauge, file, hand-saw and tenon-saw, shooting board.

- (1). Plane up to right sizes, allowing $\frac{1}{8}$ in. for cleaning off.
- (2). Set out as shown on diagram.
- (3). Bore the hole.
- (4). Cut to length and shoot the ends.
- (5). With hand-saw rip down the pieces to be cut away on each side, and cross-cut with tenon-saw, allowing about $\frac{1}{8}$ in. for cleaning off with planes and chisel.
- (6). With smoothing plane, worked obliquely to avoid the "hooks," plane down to setting-out marks, testing with square; work out the corners of the "hooks" with rebate plane and chisel.
- (7). With marking gauge and compass set out the two curved ends, and work with smoothing plane, chisel, and file.
- (8). Smooth off generally, and sandpaper.

WOODWORK COURSE FOR BOYS.

No. 10. BENCH HOOK. ($\frac{3}{4}$ full size.)

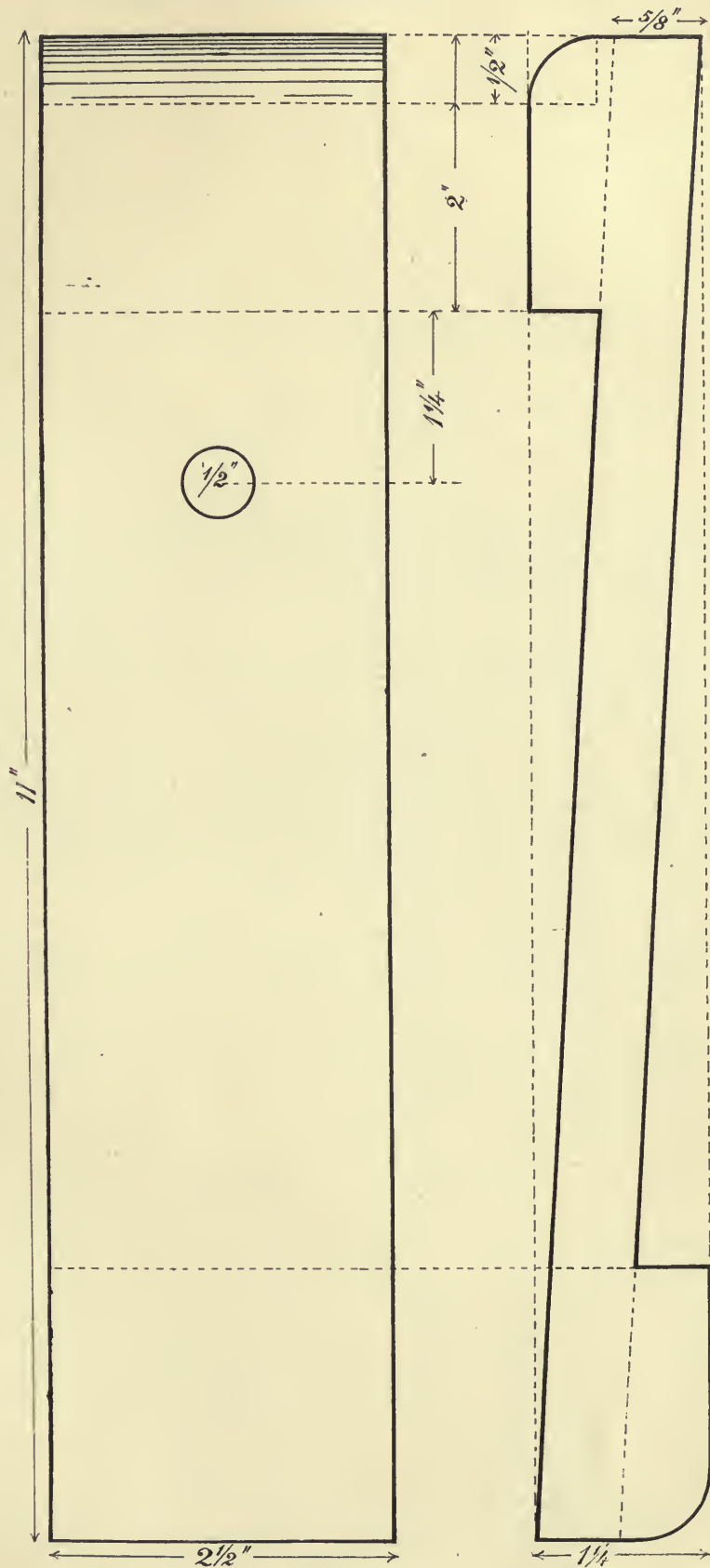

No. 11.—MORTISE JOINT.

Rough Wood—Yellow Pine.—6 in. × 1½ in. × 1 in.

TOOLS.—Jack plane and smoothing plane, square, gauge, compass, tenon-saw, firmer chisel, mortise chisel, mortise gauge, shooting board.

- (1). Plane up in one piece.
- (2). Cut in half with tenon-saw.
- (3). Set out tenon on one end of one piece, and mortise in the middle of the other piece, using square, compass, and mortise gauge. (The mortise gauge to be set to a $\frac{3}{8}$ -in. mortise chisel.)
- (4). Saw the tenon, keeping saw kerf in waste pieces.
- (5). Cut the mortise with a $\frac{3}{8}$ -in. mortise chisel, using mallet for driving, and working from each side.
- (6). Saw each piece to length, allowing $\frac{1}{8}$ -inch for shooting.
- (7). Put together, and clean off.

WOODWORK COURSE FOR BOYS.

No. 11. MORTISE and TENON JOINT. ($\frac{3}{4}$ full size.)

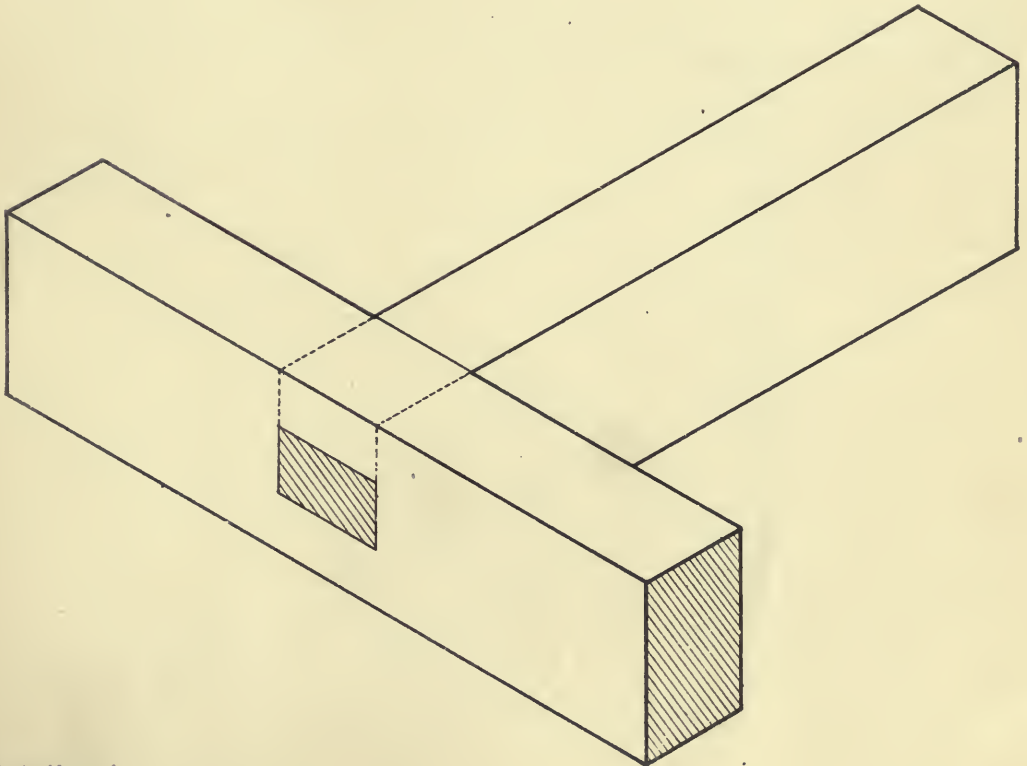
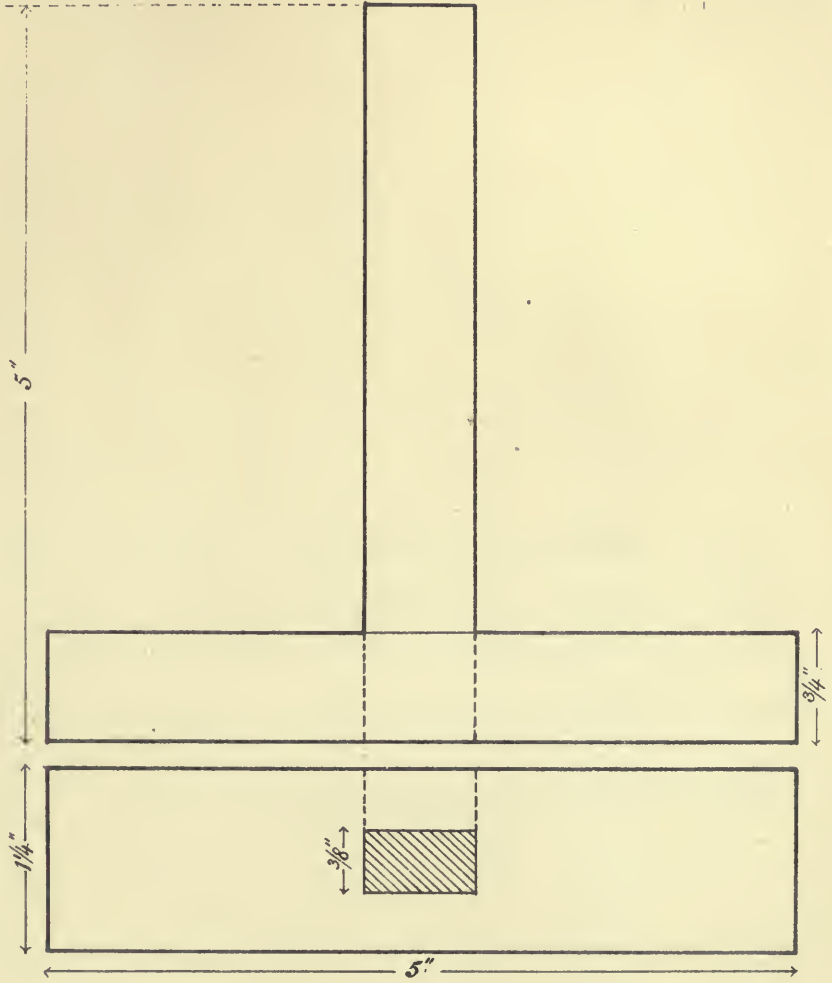

No. 12.—PEN TRAY.

Rough Wood.—11 in. × 3 in. × 1¼ in.

TOOLS.—Jack plane and smoothing plane, square, gauge, compass, gouge, spoon-iron, scraper, shooting board.

- (1). Plane up to thickness and width.
 - (2). Set out, allowing half-an-inch at each end to be cut off after gauging.
 - (3). Hollow out the tray with 1¼-in.* gouge, spoon-iron, and scraper, finishing with sandpaper.
 - (4). Cut to length, allowing ⅛-inch for shooting.
 - (5). Along underside of tray run a gauge line all round, ⅜-inch from the edges, then set out the curved sides as shown on diagram, and round over to the gauge marks with the smoothing plane, finishing with file and sandpaper.
 - (6). Finish by smoothing top and bottom with the smoothing plane.
-

* Flat gouge.



WOODWORK COURSE FOR BOYS.

No. 12. PEN TRAY. (Scale, 9" = 1')

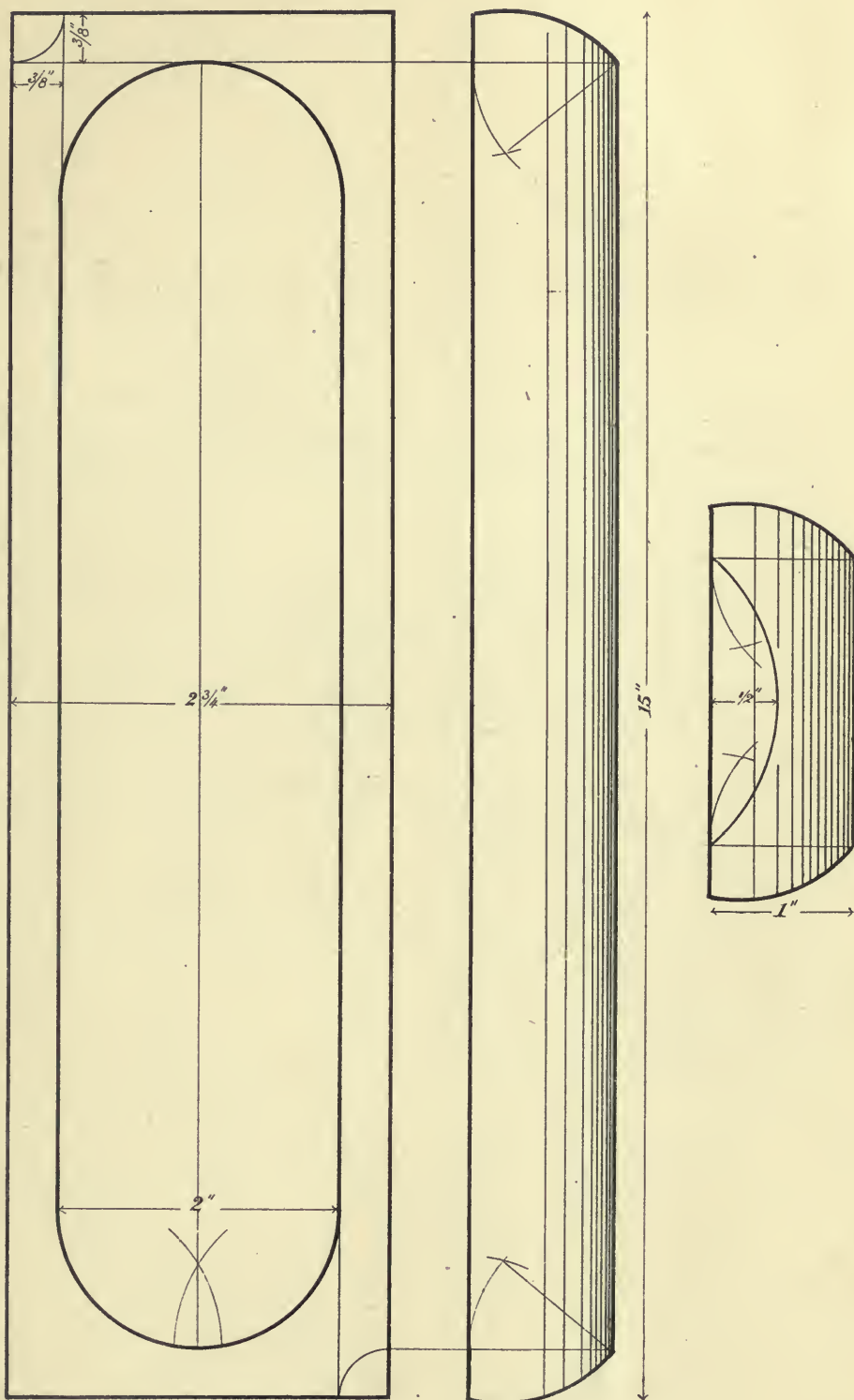

No. 13.—DOVETAIL JOINT.

Rough Wood—Yellow Pine.—12 in. × 1½ in. × 1 in.

TOOLS.—Jack plane and smoothing plane, square, gauge, compass, tenon-saw, firmer chisel, shooting board.

- (1). Plane up in one piece.
- (2). Cut in half with tenon-saw.
- (3). Set out the dovetail on the end of one piece, and the socket on the middle of the other, gauging depth of socket and thickness of dovetail with same gauge.
- (4). Halve the dovetailed end, as in making No. 5 Tee Joint, then saw the shoulders of the dovetail and pare off the oblique part with the firmer chisel.
- (5). Lay the dovetailed end on the marks for the socket and see if they tally. Then cut out the socket with tenon-saw and firmer chisel.
- (6). Cut each piece to length, and shoot.
- (7). Fit together, and smooth off.

WOODWORK COURSE FOR BOYS.

No. 13. DOVETAIL JOINT (Halved). ($\frac{3}{4}$ full size.)

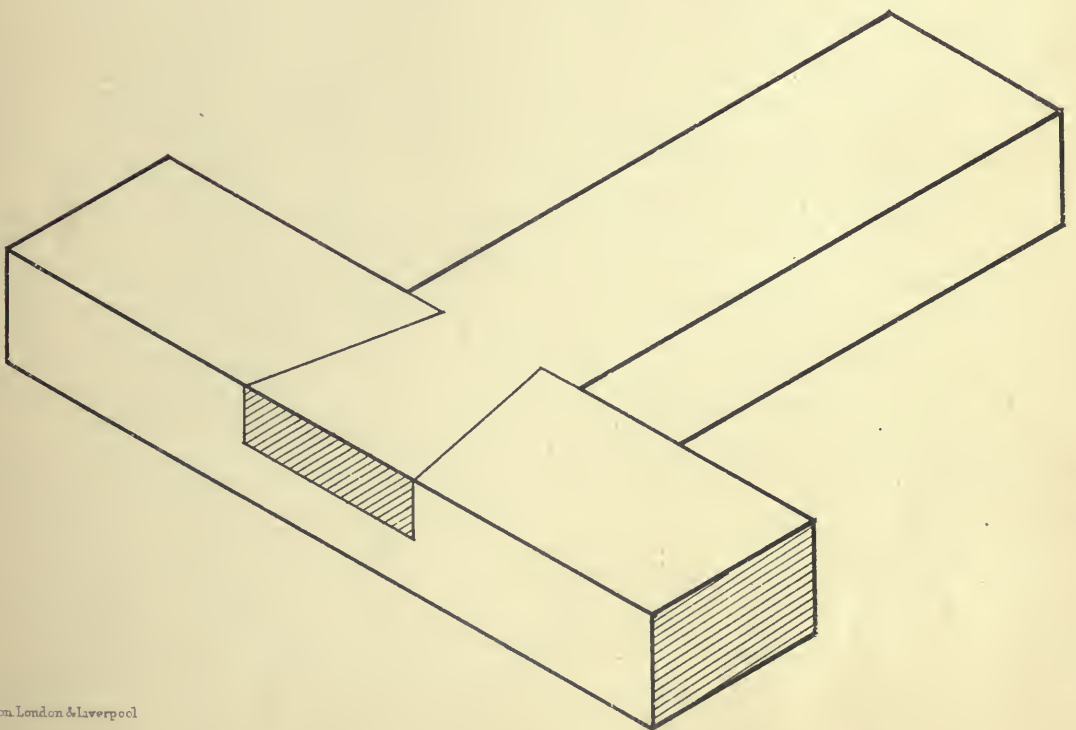
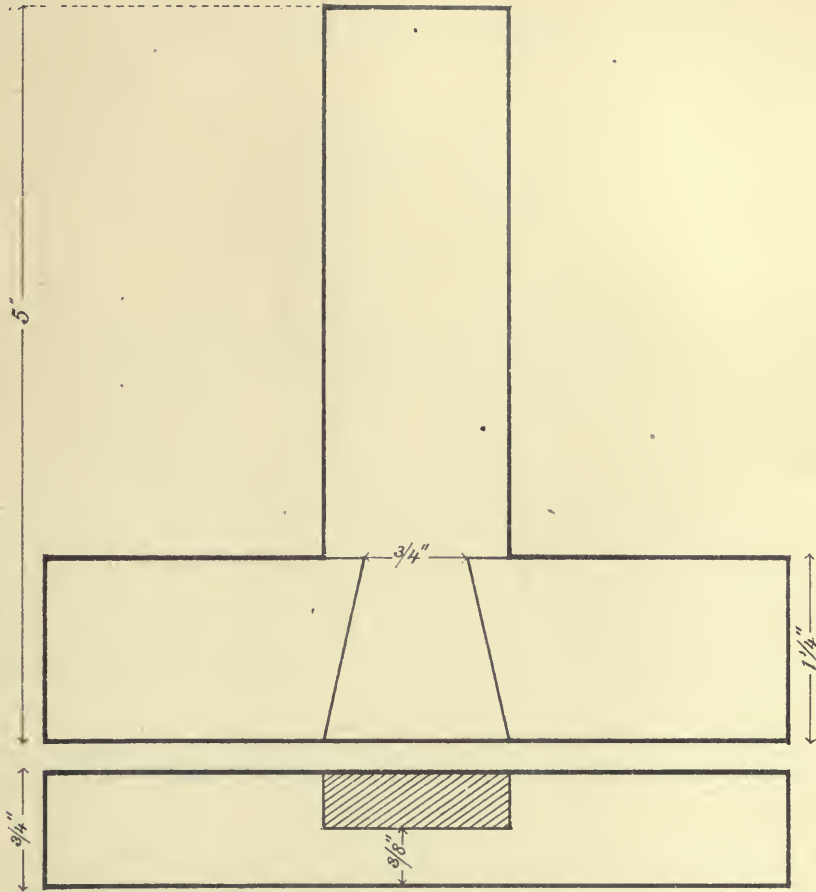

No. 14.—FLOWER POT STAND.

Rough Wood—Yellow Pine.

Piece for Rails, 17 in. × 4 in. × 1 in. Piece for Feet, 10 in. × 1½ in. × 1 in.
Nails—Oval Wire, ¾-in.

TOOLS.—Jack plane and smoothing plane, square, gauge, compass, tenon-saw, hand-saw, firmer chisel, shooting board, file, brad-awl, hammer, punch.

- (1). **Feet:** Plane up in one piece to thickness and width.
- (2). Cut in half (5 inches each piece), and square a line across lower edge of each, exactly in the centre.
- (3). Now set out the part to be cut away for feet, working from the centre line already got, $1\frac{1}{4}$ -inch on each side. This allows about $1\frac{1}{4}$ -inch for the feet.
- (4). Cut out this underneath part with saw, chisel, and knife, and file over.
- (5). Cut and shoot the feet to right length.
- (6). **Rails:** Plane up a side and edge of the full piece, and gauge to $\frac{3}{4}$ -inch thick, and plane off. This gives width of rails. Then shoot the ends to 16 inches long.
- (7). Set the gauge to $\frac{3}{4}$ -inch, and gauge down from face edge.
- (8). Saw this piece off with hand-saw, keeping saw kerf well off the gauge mark, and in the narrow strip. Lay the narrow strip aside, and plane down to gauge mark left on the broad piece, then gauge off $\frac{3}{4}$ -inch as before, and cut off. Repeat this operation until four rails have been cut off.
- (9). Now gauge the rails to right thickness— $\frac{3}{8}$ -inch, and plane off.
- (10). Set out rails for boring, preparing for two nails in each rail.
- (11). Smooth off the feet, and undersides and edges of rails.
- (12). Nail together, taking care to keep feet at right angles to rails, &c.
- (13). Smooth off, and level the top.

WOODWORK COURSE FOR BOYS.

No. 14. FLOWER-POT STAND. (Scale 6" = 1')

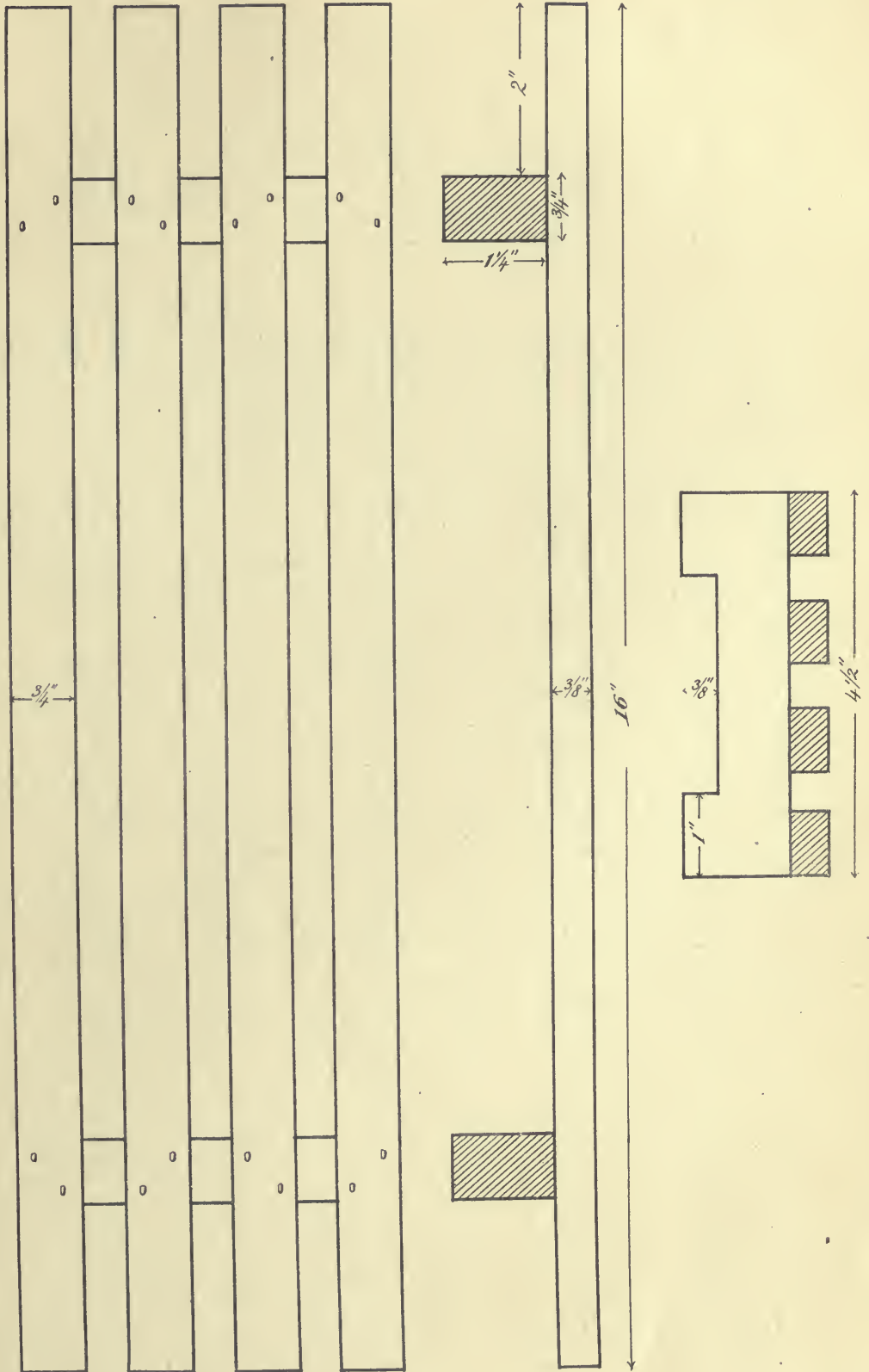

No. 15.—SIEVE REST.

Rough Wood—Basswood.—2 Pieces, 16 in. × 1½ in. × ¾ in.

TOOLS.—Jack plane and smoothing plane, square, gauge, compass, mortise gauge, mortise chisel, paring chisel, spokeshave, shooting board, file, bradawl.

- (1). Plane up to thickness and width.
- (2). Set out for mortising and tenoning.
- (3). Cut the tenons with the tenon and dovetail saws, using latter for shoulders only.
- (4). Mortise with mortise chisel and mallet.
- (5). Set out for chamfering.
- (6). Chamfer with spokeshave.
- (7). Shoot the long rails to right length.
- (8). Clean off inside.
- (9). Glue together, fixing with small wooden pins driven into holes made with bradawl, as shown in diagram.
- (10). Smooth off generally, and finish.

WOODWORK COURSE FOR BOYS.

No. 15. SIEVE REST. ($\frac{1}{2}$ full size.)

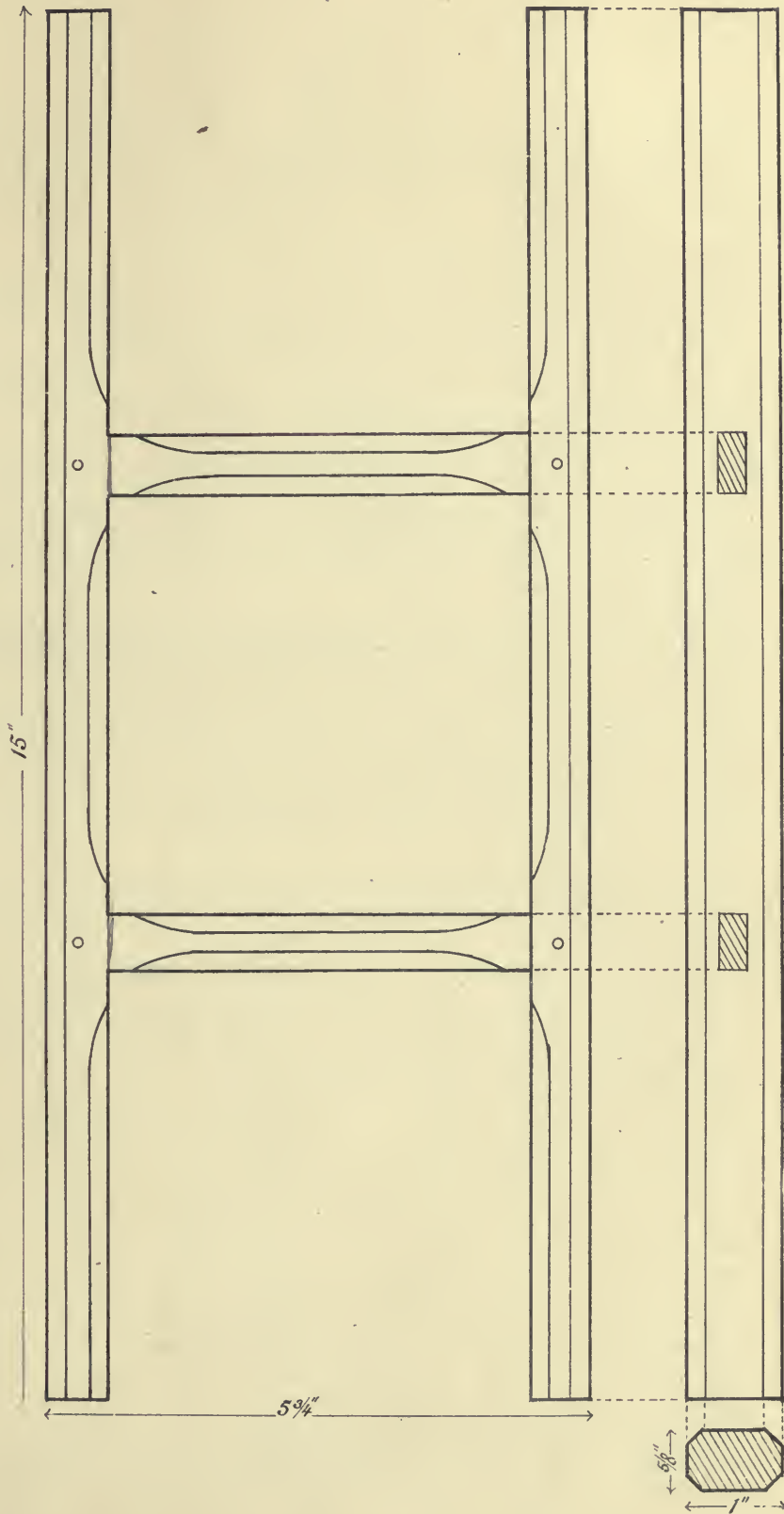

No. 16.—SCOOP.

Rough Wood—Sycamore or Chestnut.

Block 10 in. × 3 in. × 2 in.

TOOLS.—Jack plane and smoothing plane, square, compass, hand-saw, tenon-saw, bow-saw, chisel, gouge, spoon-iron, scraper, file, spokeshave, knife, brace and bit, and marking point.

- (1). Plane up a side and edge of block at right angles.
- (2). On the planed **edge** set out a side view of the top outline of the scoop, showing juncture of scoop with handle.
- (3). With hand-saw and bow-saw, saw out the shape, and level with smoothing plane and paring chisel.
- (4). Now set out the "PLAN" view of scoop as shewn in the diagram; working from a line gauged down the centre of the block.
- (5). Bore centre-bit holes ($1\frac{1}{4}$ in.) through the block where the handle joins the scoop.
- (6). Saw down on either side of handle with the hand-saw, and also on either side of scoop, and pare and plane down to marks.
- (7). Now gouge out the bowl of the scoop, fixing between bench pegs, and following the gouging with spoon-iron and scraper.
- (8). Draw the shape of the under side of the scoop (side view as shown on diagram).
- (9). Cut out the shape of the handle with the bow-saw, and carefully chop off the waste wood at the scoop end with the axe.
- (10). Work down to the lines of the handle with the spokeshave and knife, and model the rounded underneath part of the scoop end with the smoothing plane, and the handle with the knife (see sections of handle on diagram).
- (11). Set out the length of the scoop from the end of handle, and cut off with the dovetail-saw.
- (12). Round the corners of the mouth of the scoop with the knife and file.
- (13). Taper the inside edge of the mouth of the scoop with the knife and file.
- (14). Sand-paper generally, and finish.

Note.—The shape of the handle is drawn by freehand.

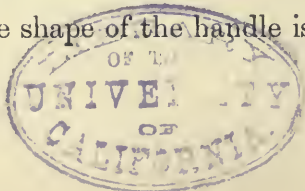

WOODWORK COURSE FOR BOYS.

No. 16. SCOOP. (Full size.)

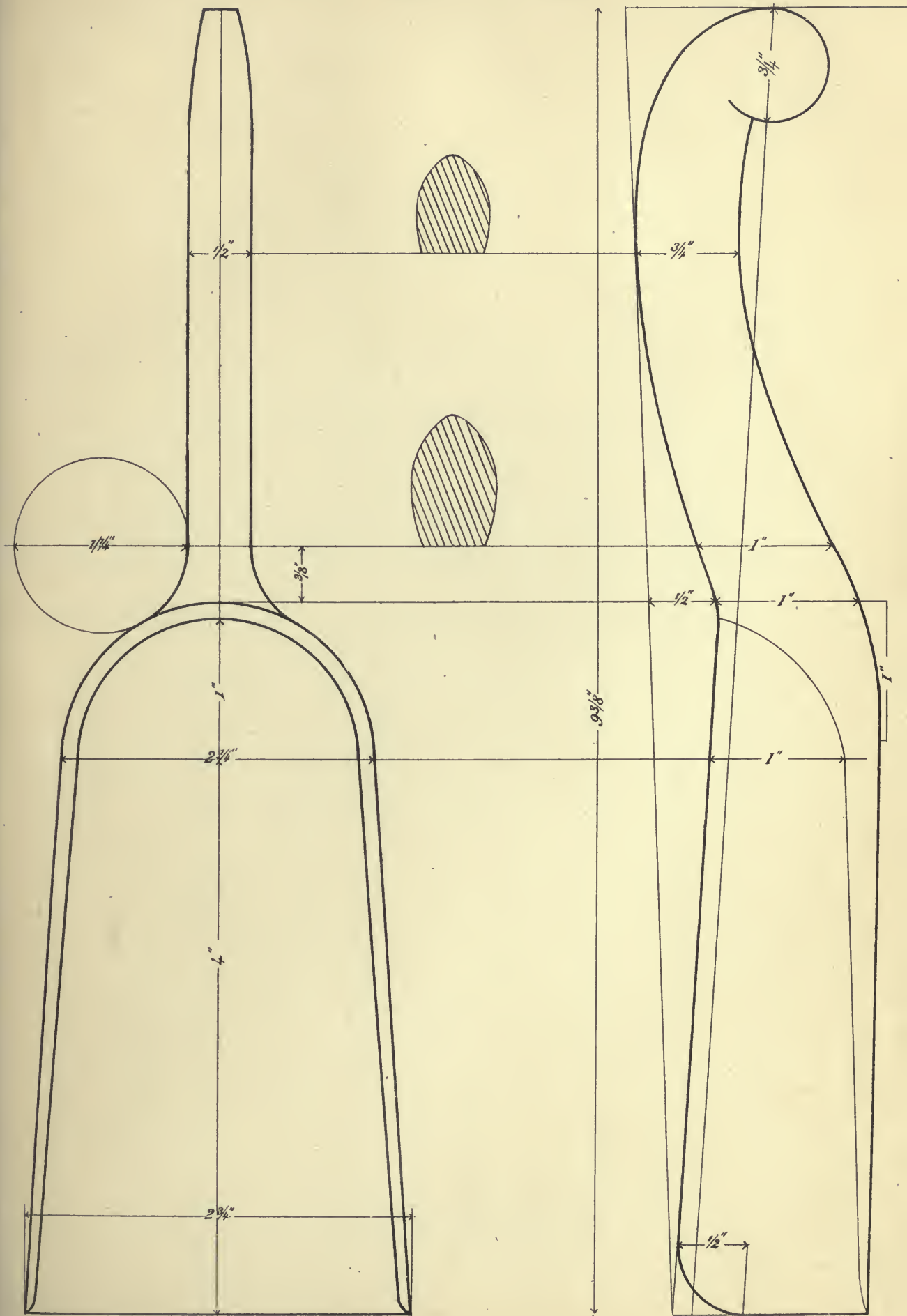

No. 17.—FLAT RULER.

Rough Wood—Baywood.— $18\frac{1}{2}$ in. \times $2\frac{1}{4}$ in. \times $\frac{3}{8}$ in.

TOOLS.—Jack plane, trying plane, smoothing plane, tenon-saw, gauge, square, brace and bit, shooting board, scraper.

- (1). Plane up to width and thickness.
- (2). Set out the bevelled edge with gauge.
- (3). Plane off with trying plane, and finish with smoothing plane.
- (4). Saw and shoot to right length.
- (5). Set out the centre-bit hole, and bore from each side.
- (6). Smooth off, finishing with scraper and sandpaper.

WOODWORK COURSE FOR BOYS.

No. 17. FLAT RULER. (Full size, broken.)

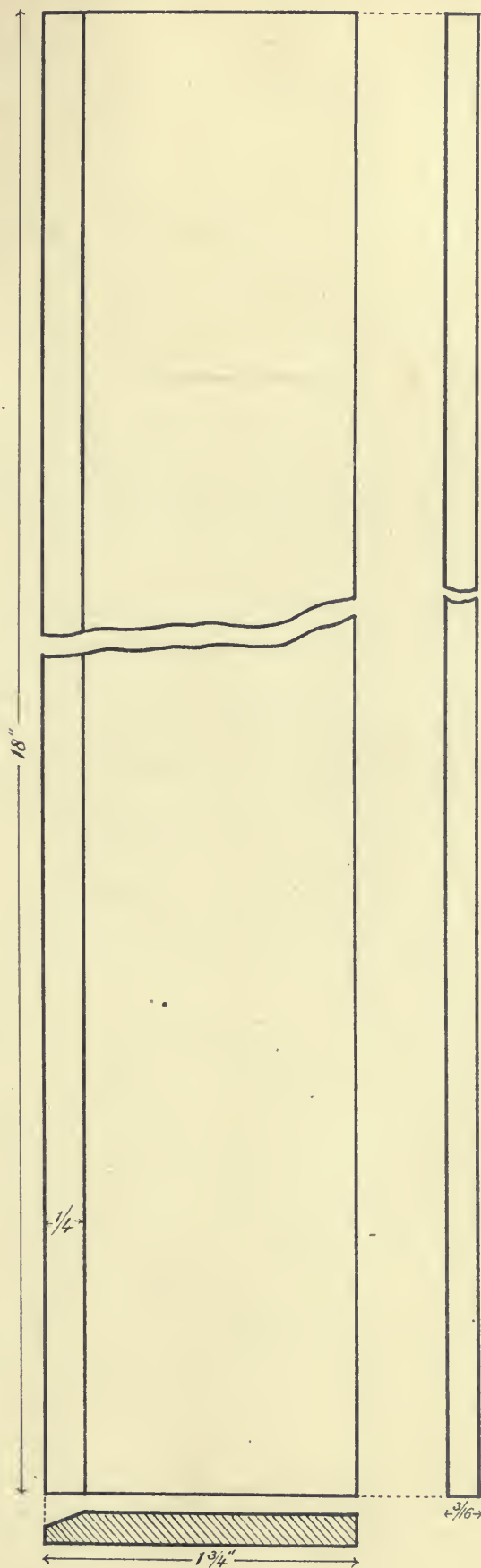

No. 18.—TRIANGULAR STAND.

Rough Wood—Yellow Pine.—26 in. × 1½ in. × 1 in. Screws, $\frac{5}{8}$ in.

TOOLS.—Jack plane, trying plane, smoothing plane, square, marking gauge, mortise gauge, set bevel, tenon-saw, dovetail-saw, mortise chisel, paring chisel, bradawl, screwdriver, countersink and brace, mallet.

- (1). Plane up in one piece.
- (2). Cut the piece of wood into three equal parts.
- (3). Fix the three pieces together in hand cramp or vice, and set out the inside measurement of stand. Then square over with the set bevel, setting out a mortise on one end of each piece, and a tenon on opposite end of each piece, and gauging with mortise gauge set to $\frac{1}{4}$ inch mortise chisel.
- (4). Saw down with tenon-saw, keeping saw kerf on inside of mortise and outside of tenon, and cutting the tenon shoulders off with dovetail-saw, and the open mortise out with mortise chisel and mallet.
- (5). Find the centre of each jointed corner by drawing diagonals, and bore and countersink for screwing.
- (6). Put together and screw up, sinking the heads of the screws just below the surface of the wood.
- (7). Smooth off and finish.

WOODWORK COURSE FOR BOYS.

No. 18. TRIANGULAR STAND. ($\frac{3}{4}$ full size.)

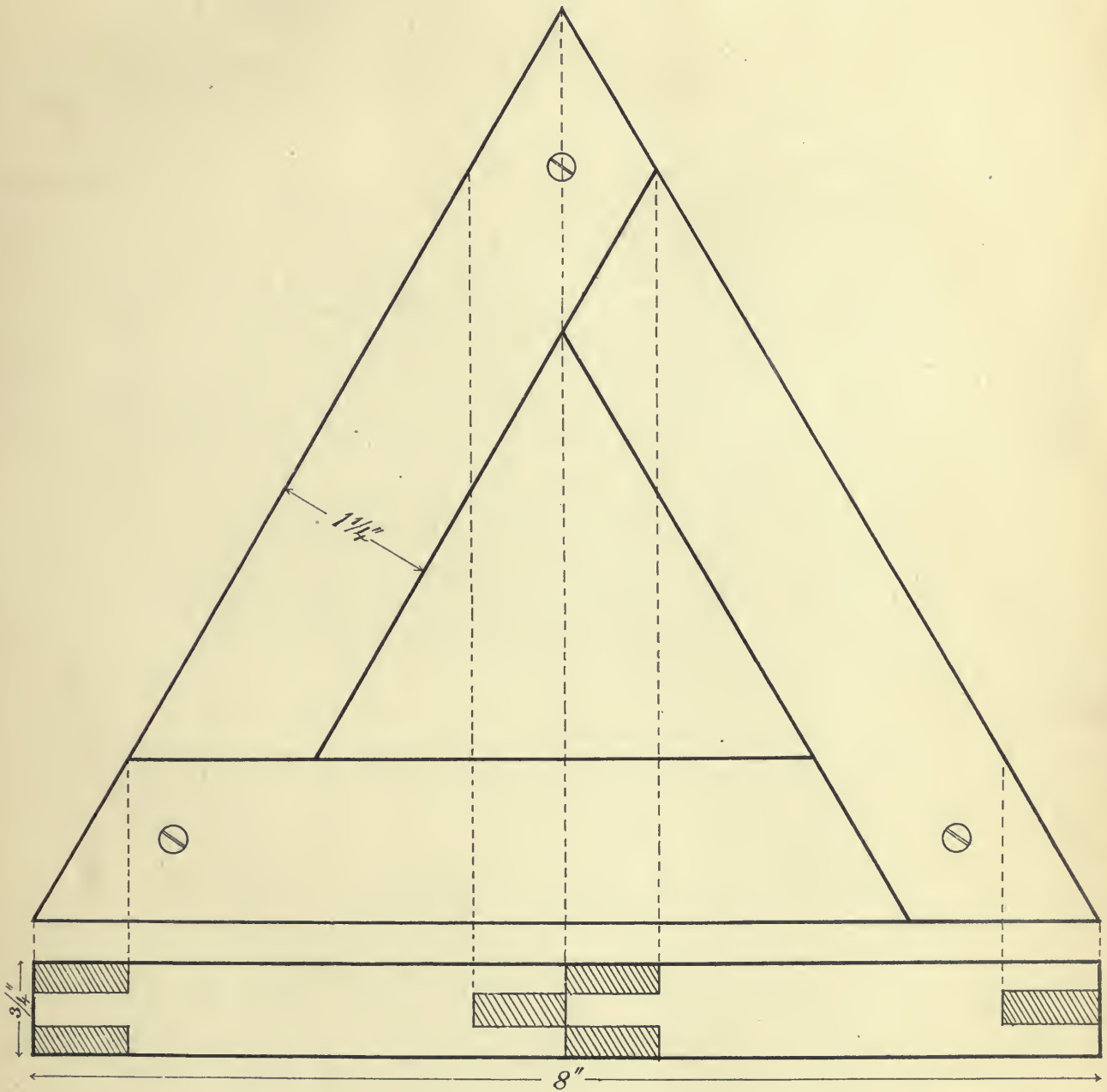

N^o. 19.—CLOTHES RACK.

Rough Wood—Yellow Pine.

Piece for Back, 17 in. \times 3½ in. \times 1 in. *Piece for Pegs*, 17 in. \times 1¼ in. \times ⅞ in.
Plates—Strip of Girth-iron, 4 in. \times ⅝ in. \times ⅛ in. *Screws*—4 Half-inch Screws.

TOOLS.—Jack plane, trying plane, smoothing plane, square, gauge, compass, tenon-saw, bow-saw, spokeshave, brace and centre-bit, firmer chisel, file, dovetail-saw, bradawl, countersink bit, screw-driver, punch, and cold chisel.

- (1). Plane up a side and an edge of back.
- (2). Set out shape of back.
- (3). Bore the holes for the pegs.
- (4). Plane up wood for the pegs.
- (5). Set out shape of pegs, and on the ends inserted into back describe circles with the brace-bit used for boring the holes.
- (6). With dovetail-saw, chisel, knife, and file, fit the pegs into the back, seeing that they stand out quite square.
- (7). Now saw the back to shape with the bow-saw, and finish the rounded ends with spokeshave, chisel, and file, planing to width first.
- (8). Set out for bevelling with gauge, and bevel the sides with the planes, and the ends with the spokeshave and chisel.
- (9). Shape the pegs according to the diagram, rounding the top edge, (shown shaded) and chamfering the underneath edges and the edges of the rounded ends, as shown, with the spokeshave and knife. (Small side view shows that the hook of the peg is rounded towards the back ; set this out with the compass and round with the knife).
- (10). Now smooth off the front side of the "back," and glue in the pegs, which ought to project through the holes about a quarter of an inch.
- (11). Saw the projecting ends of the pegs that come through "back" off, and smooth over with smoothing plane.
- (12). Now, out of the iron girthing, make the hanging plates.
File to width, then on each end of the 4-inch piece provided describe semicircles, and with cold chisel and file round up. Then cut to length, and square the ends. With sharp punch set out the screw-holes, and drill through with brace and hole-rimer, countersinking for screw heads.
- (13). Sink the plates into the back with dovetail-saw and chisel, and screw on with half-inch screws.
- (14). Sandpaper all over and finish.

WOODWORK COURSE FOR BOYS.

No. 19. CLOTHES RACK. (Full size, half length.)

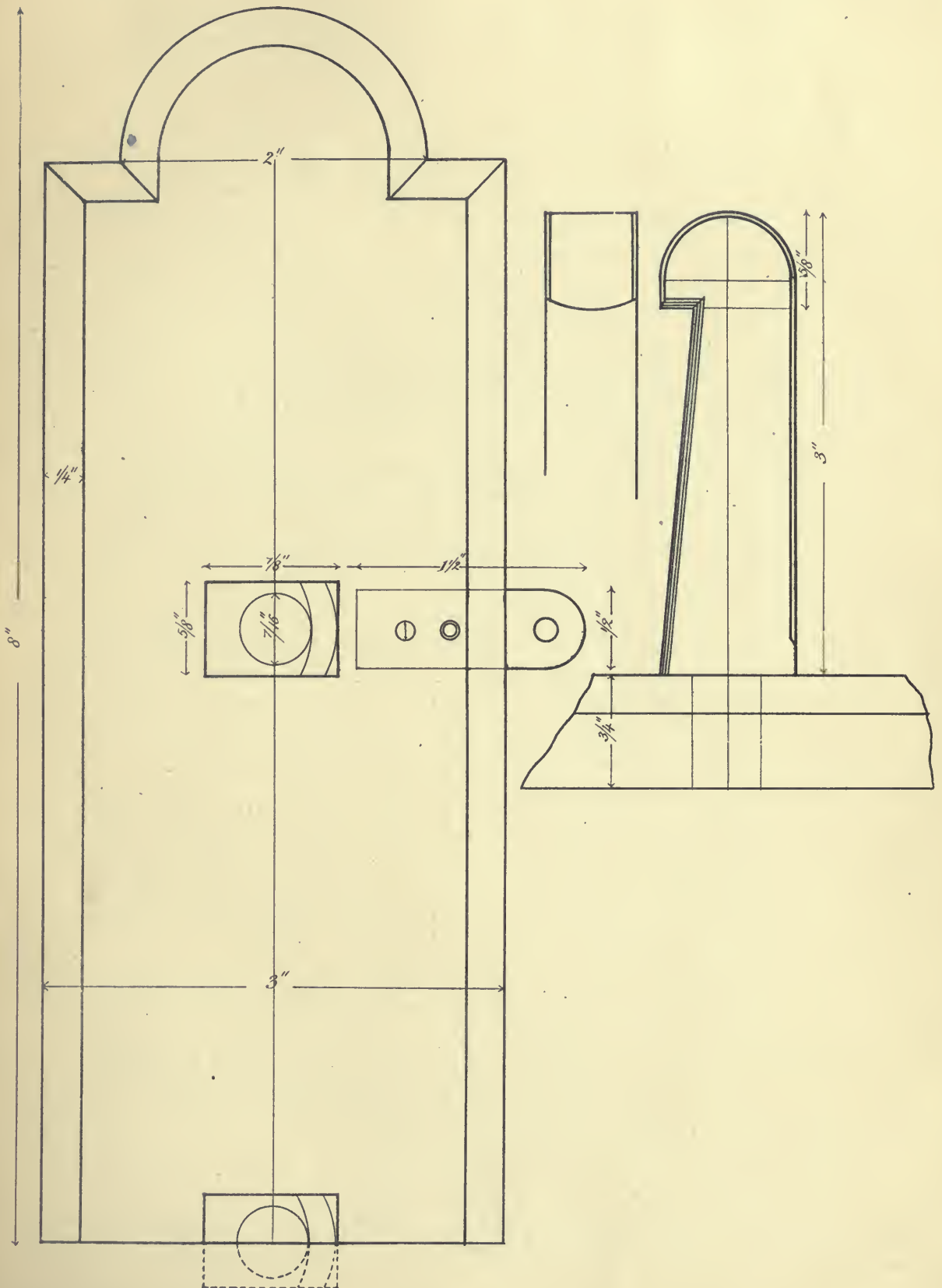

No. 20.—BOX DOVETAIL.

Rough Wood—Yellow Pine—11 in. × 3½ in. × ¾ in.

TOOLS.—Planes, square, marking gauge, cutting gauge, shooting board, tenon and dovetail saws, chisels, mallet, marking point.

- (1). Plane up in one piece.
- (2). Shoot each end square in the shooting board.
- (3). Set the cutting gauge to the exact thickness of the wood, and gauge across each face of block at both ends.
- (4). Now set out the shape of the dovetail pins (in this case, two side pins and one middle pin). It will be noticed on diagram, that in the direction of the length of the wood, and on the outside, that the pins have parallel sides, and that the two outside pins are thicker than the middle pin. In setting out, it is perhaps best to set out the edge of the wood on which the measurement of the narrow part of the pins come first, *e.g.*, the narrow part of the two side pins is $\frac{3}{16}$ -inch, and the narrow part of the middle pin $\frac{1}{8}$ -inch. When these measurements are properly marked off (the wood for the purpose of setting out ought to be held in vice endway up), set the bevel to a slope of $\frac{5}{8}$ -inch in 3 inches, and mark off the end slope of the pins. Square down with try square the straight narrow parallel side of the pins to the gauge marks.
- (5). Now the pins are ready for cutting, fix the block in the bench vice, endways up, with the narrow side pins facing worker, and saw straight down by the outside of the parallel marks and at proper angle of end of pins. (The saw is held a little to the right or a little to the left according to slope of pin, but the plane of the blade must be kept perfectly upright.)
- (6). After sawing down take the broadest paring chisel that will go between the pins easily, and from each side cut the pieces out for the socket, driving the chisel with mallet, and having the wood lying flat on the bench, making the first cuts a little way from the gauge mark; then putting edge of chisel right into the mark and making final stroke.
- (7). Now cut the block into two pieces and mark off for the sockets, holding the pin piece in proper position on the socket piece, and following shape of pins with marking point or sharp, hard pencil.
- (8). Then square across the end of the grain of the socket piece and cut down, keeping saw kerf on the piece to be cut away.
- (9). With small chisel cut out middle socket.
- (10). With dovetail saw cut off the shoulders.
- (11). Cut the two pieces to length and shoot.
- (12). Smooth off the insides and glue together.
- (13). Smooth off outsides and finish.

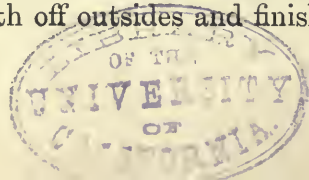

WOODWORK COURSE FOR BOYS.

No. 20. BOX DOVETAIL. (Full size, broken.)

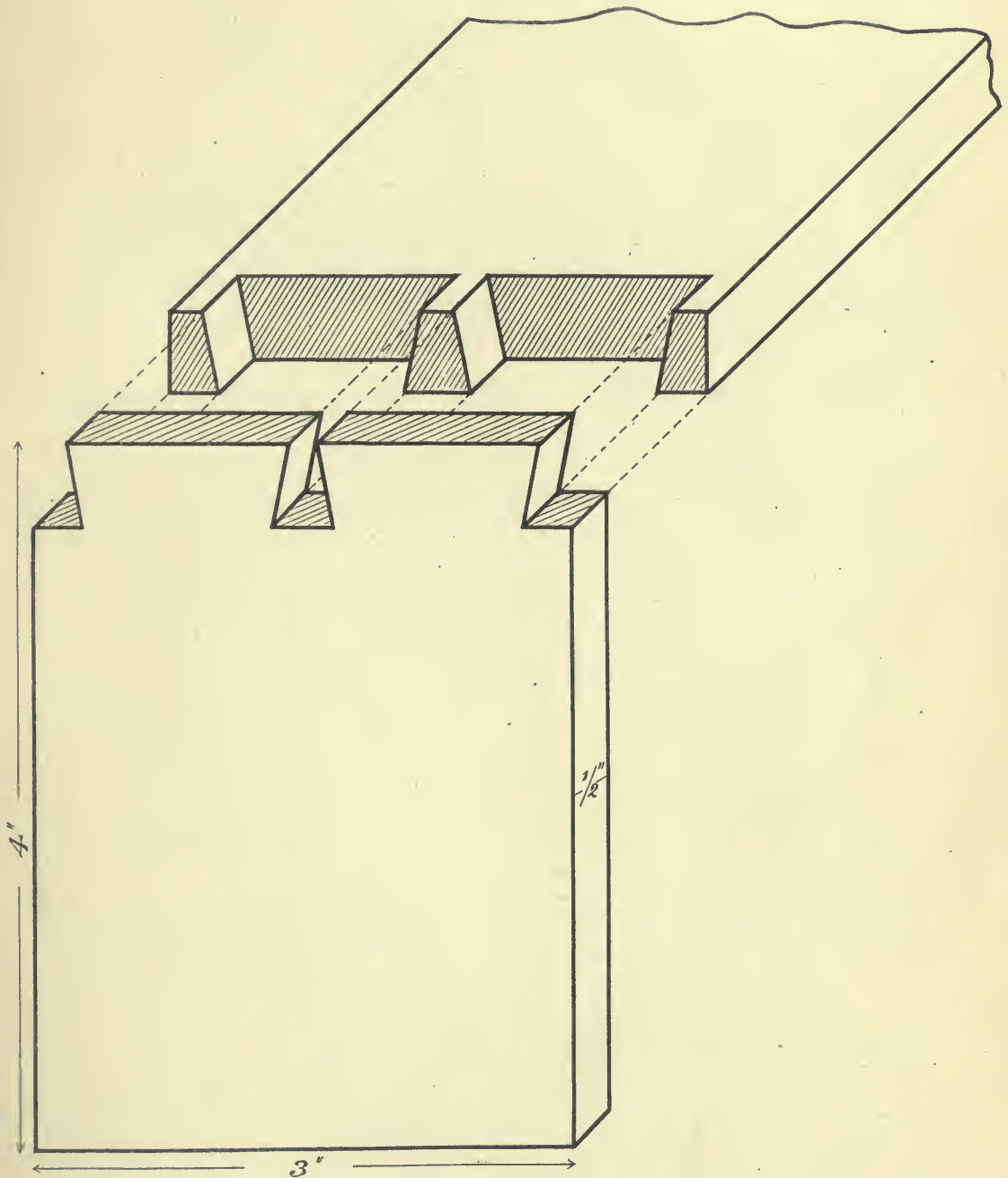

No. 21.—TOWEL ROLLER.

Rough Wood—Basswood.

Roller $18\frac{1}{2}$ in. \times 2 in. square. Rests 12 in. \times 3 in. \times 1 in.

TOOLS.—Jack plane, trying plane, smoothing plane, tenon-saw, bow-saw, brace and centre-bit, chisels, inside gouge (for paring), spokeshave, file. (Such tools as the square, gauge, and compass, may now be taken for granted. They are in constant use, of course.)

- (1). **Rests:** Plane up a side and edge in one piece.
- (2). Cut in half and set out shape and holes for the roller to run in.
- (3). Cut to shape with bow-saw, working to a finish with the chisel, inside gouge, and spokeshave, and cutting out the grooved entrance for roller pin on one of the rests. (See diagram.)
- (4). Gauge the rests to thickness and plane off.
- (5). Now take the rough piece for the roller and plane it up.
- (6). Then set out on one end the method of rounding, as shown in No. 7—Round Ruler.

At the same time set out the shoulder length of the roller, allowing $\frac{3}{4}$ -inch off at each end for the pins. Taking the centre got for the octagon, describe a circle at each end of block with the centre-bit used for boring the rests. Gauge lines across the end of the block, just clearing the pin. This will show the circle marked for the pin enclosed in a square. Cut tenon-saw cuts down by these marks, stopping before quite reaching the shoulder of the roller. Then in the same way cut the shoulders, stopping before reaching the down cuts. In this way the waste pieces are left on the block until after the rounding is done.

Now gauge for rounding, as shown in No. 7—Round Ruler, plane to octagonal shape, and then round.

- (7). The shoulders can now be cut off and the pegs properly rounded to fit the holes in the rest slackly. The length of the pins ought to be about $\frac{1}{8}$ -inch less than the depth of the holes in the rests.
- (8). File and sandpaper the roller, and smooth up the rests.

Note.—This model can be improved by making a back board ($20\frac{1}{4}$ -in. \times $6\frac{1}{2}$ -in. \times $\frac{5}{8}$ -in.), with bevelled edges, and screwing the rests on to it, inserting the screws from the back. If this is done, the rests should not be fixed quite tight up against the shoulders of the roller. About $\frac{1}{8}$ -inch should be allowed for play.

WOODWORK COURSE FOR BOYS.

No. 21. TOWEL ROLLER. (17" × 17/8")

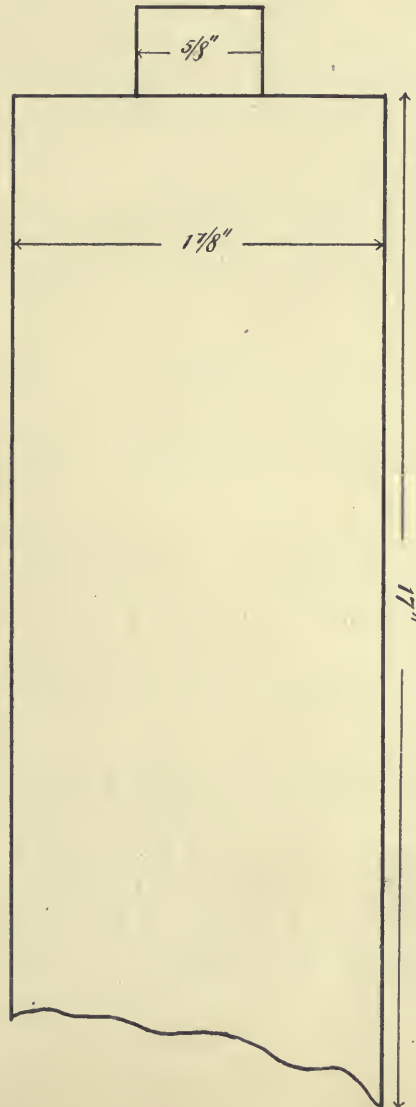
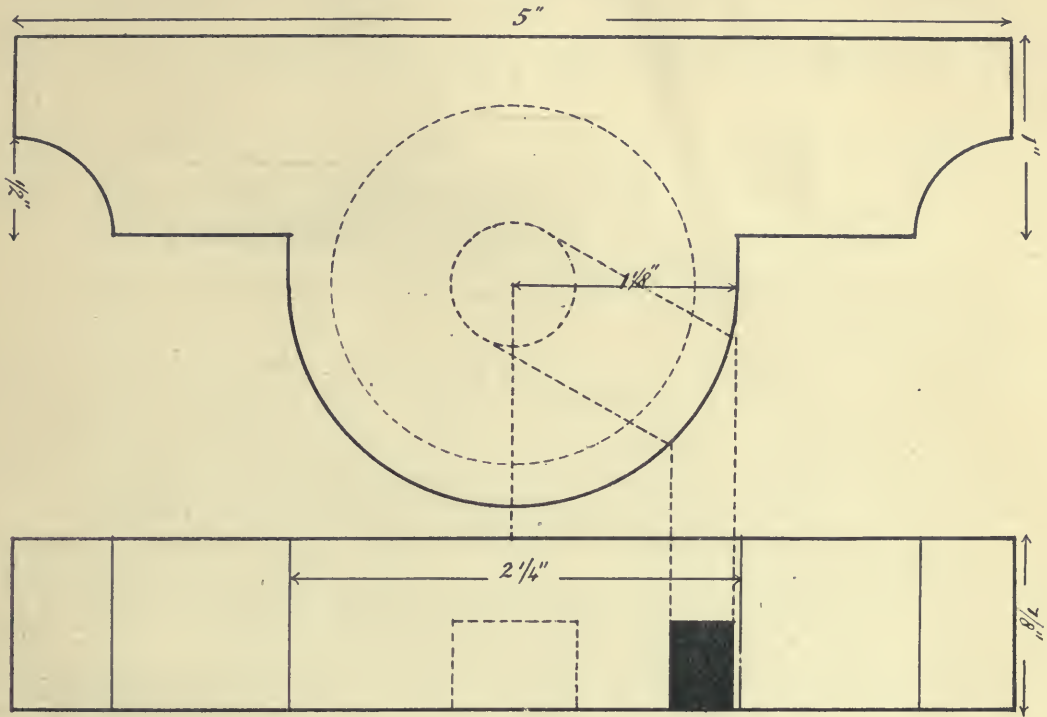

No. 22.—SOAP BOX.

Rough Wood—Yellow Pine.

*Back Piece and Bottom, 10 in. × 6½ in. × ½ in. Front Piece and Ends,
16 × 3 in. × ½ in. Nails—1 in. Oval Steel Nails.*

TOOLS.—Jack plane and smoothing plane, tenon-saw and bow-saw, brace and centre-bit, cutting gauge, dovetail saw, shooting board, firmer chisels, gouge, spokeshave, file, bradawl, hammer and punch.

- (1). **Back and Bottom** : Plane up in one piece to thickness and width.
- (2). Set out the shape of the back, including the depth of the notch for the ends and the length. Continue the gauging for the notched-out piece right along to the end of the wood, in order to get right width for the bottom, which it will be observed is only dovetailed into the back, the ends and front of box being simply nailed on it.
- (3). Cut off the piece for the bottom, plane down to the gauge marks mentioned, and shoot to right length, which is $3\frac{5}{8}$ in.
- (4). Before notching the back, shoot the end to be dovetailed. Then cut out the notches with dovetail saw.
- (5). Set out one end of the bottom and the back for dovetailing, with cutting gauge, compass, bevel and square, according to dotted lines on the diagram, working as described in Model No. 20.
- (6). Cut out the shape of the back with the bow-saw, and finish the curves with the spokeshave and file. Bore the hole shown, with the brace and $\frac{1}{2}$ -in. centre-bit.
- (7). Smooth up the inside of the back and bottom, and glue together.
- (8). Now take the rough wood for ends and front, and plane it up in one piece.
- (9). Cut it into two pieces, one 7-in. long for the front of box, and the other 9-in. long for the two ends.
- (10). Shoot the front to right length, 6-in.
- (11). Shoot the ends to right length, $3\frac{5}{8}$ -in., allowing about $\frac{1}{16}$ -inch for cleaning off.
- (12). Set out the parts cut away, to relieve the top edges of the box, as shown on the diagram.
- (13). Saw them out with the bow-saw and finish with inside gouge, chisel, and knife.
- (14). Smooth up the insides of the three pieces, and bore them for nailing.
- (15). Glue and nail the end pieces on first, quite level with bottom of box, then glue and nail the front piece on.
- (16). Punch in the nails below the level of the wood.
- (17). Smooth up the outside of the box and finish with sandpaper.

Note.—The notches spoken of are the pieces cut off the sides of the back to allow the ends to fit in level.

WOODWORK COURSE FOR BOYS.

No. 22. SOAP BOX. (Full size.)

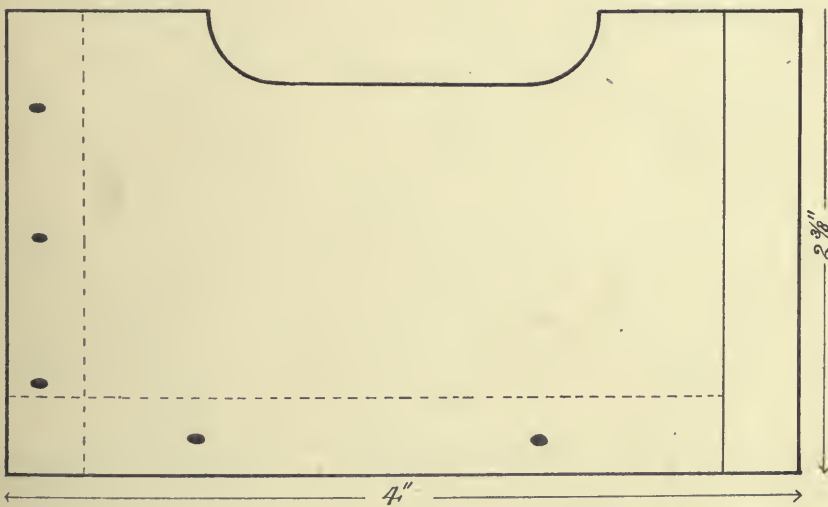
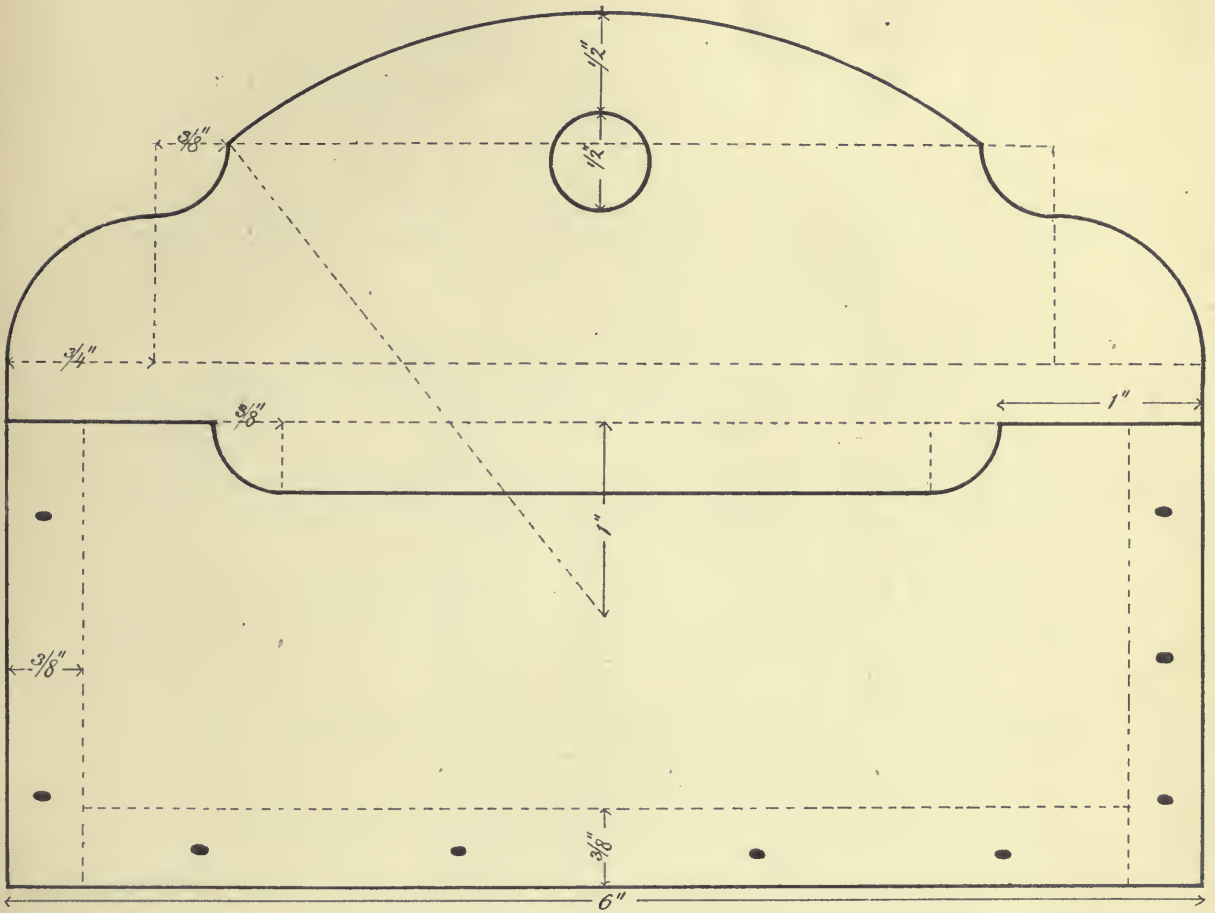

(a.) Shows dovetailing of back and bottom.

N O. 23.—BOOK CARRIER.

Rough Wood—Yellow Pine and Birch.

Boards—20 in. × 7 in. × $\frac{3}{4}$ in. *Clamps, two pieces*—8 in. × 2 in. × $\frac{3}{8}$ in.

Handle—8 in. × $2\frac{1}{4}$ in. × $\frac{7}{8}$ in. *Screws*—Two 1 inch.

TOOLS.—Jack plane and smoothing plane, tenon-saw, chisels, old woman's tooth plane, bevel, bow-saw, spokeshave, knife, gouge, gimlet, screwdriver, and shooting board.

- (1). **Boards** : Plane up side and edge in one piece.
- (2). Set out one end for clamping as shown in the diagrams, with bevel, gauge, and straight-edge.
- (3). Cut out the sockets for the clamps with tenon-saw, chisel, and old woman's tooth plane.
- (4). Fit the clamps into the sockets with the jack plane.
- (5). Glue the clamps into the sockets, using glue only at wide end for about an inch in.
- (6). Let the glue harden, and plane up the wood for the handle, one side and one edge only at first.
- (7). Set out the shape of the handle as shown on the diagram.
- (8). Cut to rough shape with the bow-saw, and square up with the spokeshave, smoothing plane, chisel, and gouge.
- (9). Gauge to thickness and plane off.
- (10). Round the top part of the handle with the smoothing plane, and the lower part with the knife.
- (11). Chamfer the edges, as shown, with spokeshave and knife.
- (12). Bore the holes for the screws with the gimlet, counter-sinking for the heads if flat-headed screws are used.
- (13). Finish the handle with the file and sandpaper.
- (14). Now plane up the boards to the right size, shooting the ends in the shooting board.
- (15). Set out the notches for the straps, and cut them out with the tenon-saw, chisel, and knife.
- (16). Smooth up the boards, and sandpaper.
- (17). Screw the handle on to the top board.

WOODWORK COURSE FOR BOYS.

No. 23. BOOK CARRIER. (Full size.)

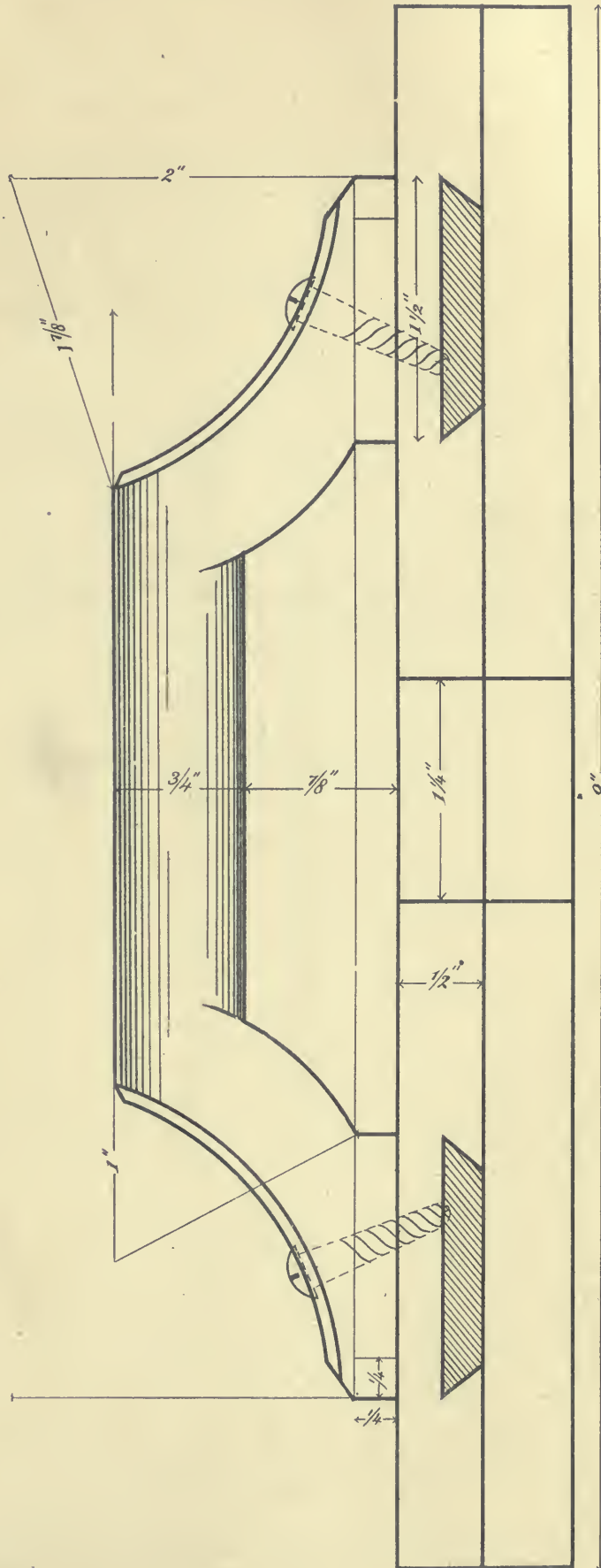

No. 23a.—BOOK CARRIER.

For Instructions, *see* previous page.

WOODWORK COURSE FOR BOYS.

No. 23a. BOOK CARRIER. (Full size.)

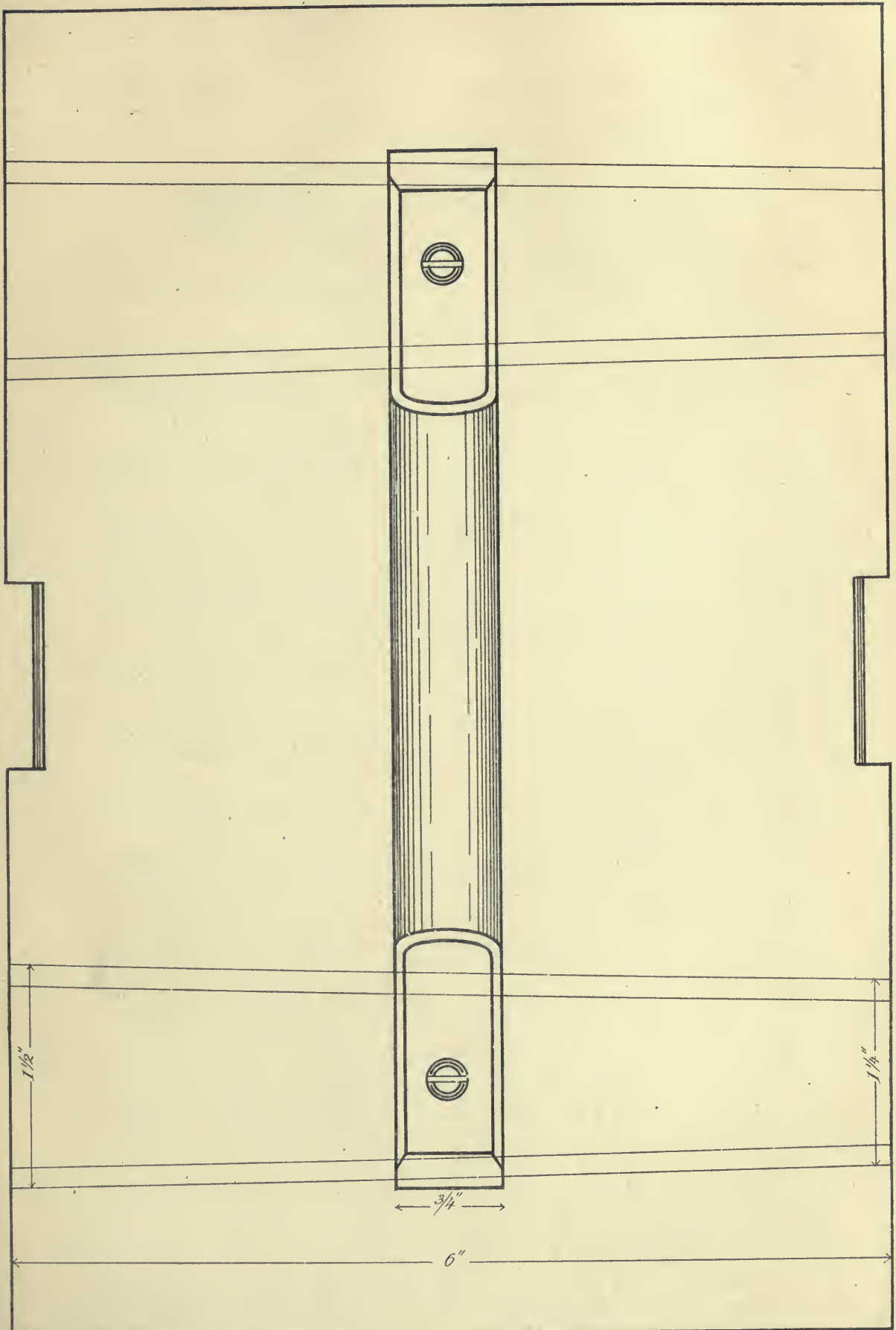

No. 24.—K N I F E B O X .

Rough Wood—Yellow Pine.

Handle Partition, 12 in. × 4½ in. × ⅝ in.

Sides and Ends, two pieces, 20 in. × 2½ in. × ⅝ in. Bottom, 13½ in. × 8½ in. × ½ in.

Nails—1-inch Oval Steel Nails.

TOOLS.—Jack plane, smoothing plane, shooting board, tenon-saw, dovetail-saw, bow-saw, brace and bits, chisels, spokeshave, knife, file, cutting gauge, bradawl, hammer, punch.

- (1). **Sides and Ends**: Plane up the two pieces cut out for this purpose.
- (2). Saw an end and a side off each piece after they have been planed up.
- (3). Shoot to right length, and gauge with cutting gauge for dovetailing.
- (4). Set out for dovetailing according to diagram, and follow the same system of working as that explained in Model 20.
- (5). Set out the groove for the partition on the inside of each end (*see* projection at side of diagram).
- (6). Cut this groove out with the dovetail-saw and chisels.
- (7). Smooth off the insides of the pieces dovetailed, and glue together, squaring and setting aside until hard.
- (8). **Handle**: Plane up the wood for the handle, and set out the shape on one side.
- (9). Cut to shape with the bow-saw, boring out the curved ends of handle-hole with the brace and bit, and inserting the bow-saw for the other parts.
- (10). Finish the curves of the handle with the spokeshave, knife, and file.
- (11). Now shoot the ends of the handle-partition to length for insertion in the ends, and cut out the notches at the top side (*shown* in diagram).
- (12). See that the handle fits properly, smooth off the sides, and glue it in.
- (13). Plane up the piece for the bottom, allowing $\frac{3}{8}$ -inch for projection all round.
- (14). Curve the edges, (as shown on diagram), with the smoothing plane, finishing them with file and sandpaper.
- (15). Bore the bottom for nailing with bradawl, and smooth off the inside.
- (16). Now level the box to fit the bottom, with smoothing plane, and smooth off and sandpaper the sides.
- (17). Nail the bottom on to the box, and sink the nails below the surface of the wood with the punch.
- (18). Smooth off and level the bottom, and finish up generally.

WOODWORK COURSE FOR BOYS.

No. 24. KNIFE-BOX. (Full size.) Sides and Ends.

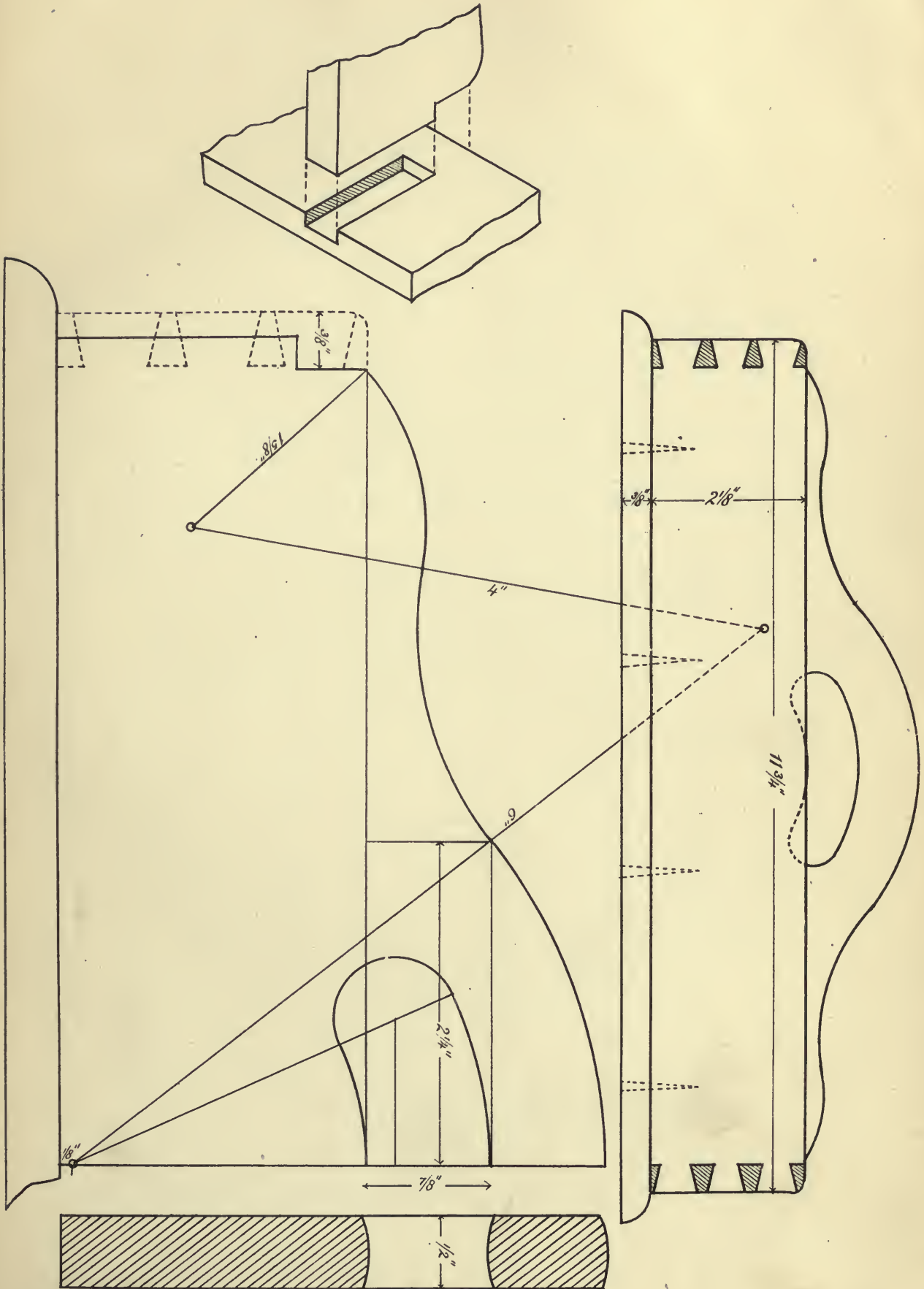

No. 24a.—KNIFE-BOX.

For Instructions, *see* previous page.



WOODWORK COURSE FOR BOYS.

No. 24a. KNIFE-BOX. (Full size.) Handle.

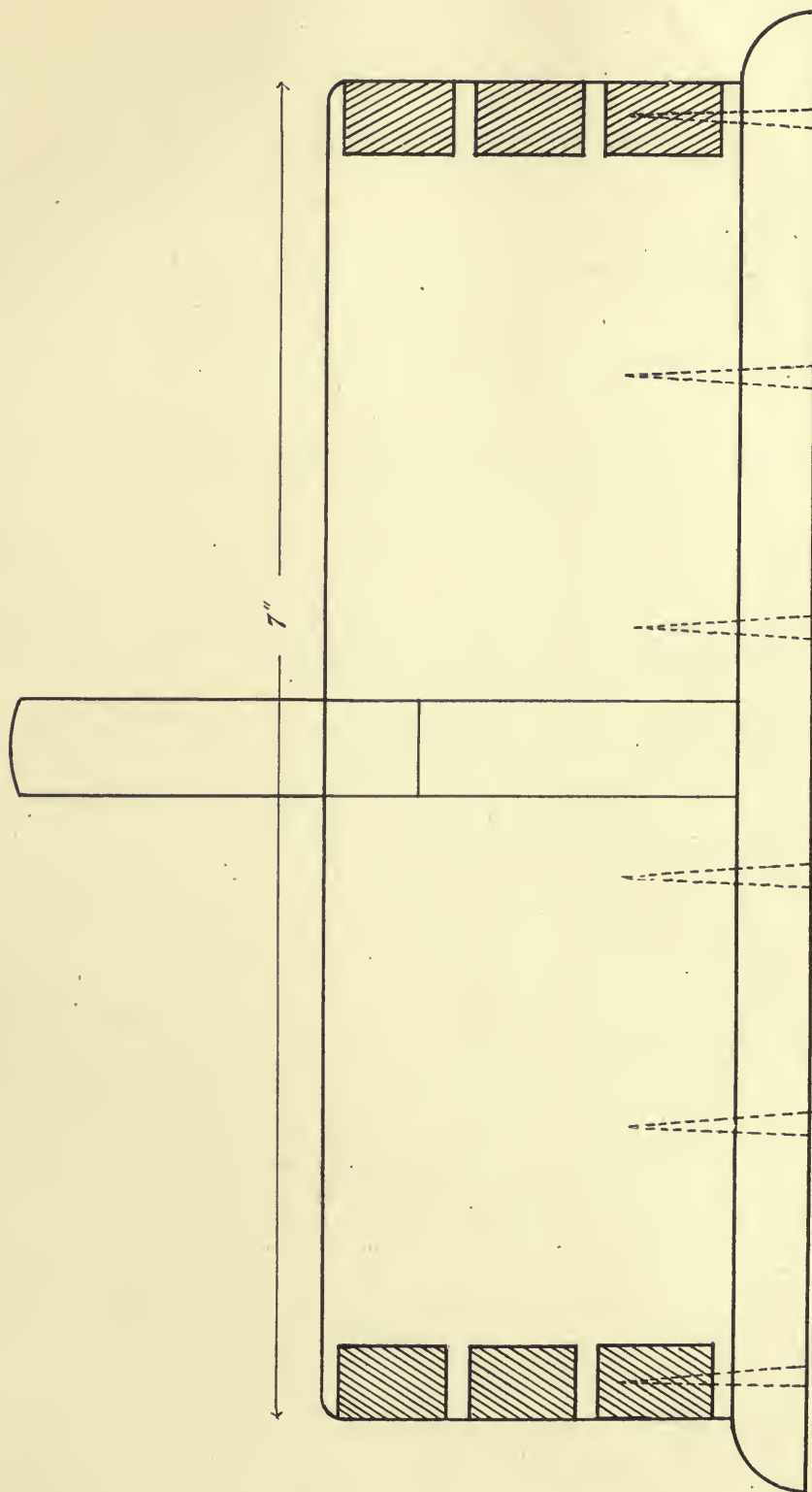

No. 23.—AXE HANDLE.

Rough Wood—Ash.—20 in. × 3 in. × 1¼ in.

TOOLS.—Jack plane, smoothing plane, tenon-saw, bow-saw, spokeshave, draw-knife, rasps, file, and sandpaper.

- (1). Plane up the wood on one side and edge, and to thickness, not to width.
- (2). Set out length, and saw off with tenon-saw, allowing about $\frac{1}{8}$ -in. for paring off afterwards.
- (3). Now draw the shape on the face side of the wood.
- (4). Cut out the shape, the curved parts with the bow-saw, and the straight parts with the hand-saw.
- (5). Now level down to marking lines, the straight end part of the handle with the smoothing-plane, and the curved part with the spokeshave. (That is, level down to marking lines simply at right angles to the sides ; don't attempt to round).
- (6). Now draw the elliptical shapes of the ends as shown in diagram, and chamfer the edges of the handle almost down to these marks with draw-knife and plane.
- (7). Then commence rounding, working the straight end with the smoothing plane, and the curved part of the handle with the spokeshave, finishing with rasp, file, and sandpaper.
- (8). Now pare the ends flat, and at proper angles to the rest of handle, and finish generally.

WOODWORK COURSE FOR BOYS.

No. 25. AXE HANDLE. (Scale, 6" = 1')

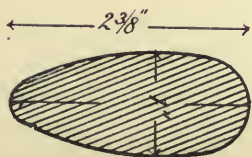
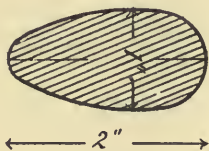

No. 26.—OBLIQUE DOVETAIL.

Rough Wood—Yellow Pine.—11 in. \times 2 $\frac{3}{4}$ in. \times $\frac{1}{2}$ in.

TOOLS.—Jack plane, smoothing plane, tenon and dovetail saws, bevel, cutting gauge, chisel, and mallet.

- (1). Plane up to thickness.
- (2). Set the bevel to right inclination of sides as shown on diagram, $\frac{1}{2}$ -inch in 2 inches.
- (3). Bevel one edge to this inclination, and then set out width, and bevel again.
- (4). Now cut the piece in half with tenon-saw, and with bevel at same angle, set out the slope of the ends and cut off.
- (5). Now set another bevel to one-third the number of degrees that the inclination is larger than a right angle, (that is, to one-third of the slope of half-an-inch in 2 inches). This gives the angle that the ends of the pieces of wood make with the sides.
- (6). Now shoot the sloped ends of the two pieces for the joint with the smoothing plane, testing with the first bevel for the general slope (stock of bevel resting against lower edge of wood), testing with second bevel for angle that the end makes with the face side of the wood (stock against side of wood).
- (7). Set out for dovetailing, after gauging with the cutting-gauge—pins first, taking centre of end of wood, and with first bevel running a pencil line across parallel to the narrow edges, and similar lines $\frac{1}{8}$ -inch from sides. The middle line marks centre of middle pin. The side lines mark narrow end of side pins from which slope of pin must start. Then set the compass to $\frac{1}{16}$ -inch, and set off $\frac{1}{16}$ -inch slope for the pins. With first bevel, square over the setting out for the pins on the outside, resting stock on end of wood, so that the blade runs parallel to the long edges, and the pins run in the direction of the grain of the wood.
- (8). Now follow same method of working as in common dovetailing.
- (9). Smooth off the inside and glue together.
- (10). Cut to length and smooth off generally.

WOODWORK COURSE FOR BOYS.

No. 26. OBLIQUE DOVETAIL. (Full size, broken.)

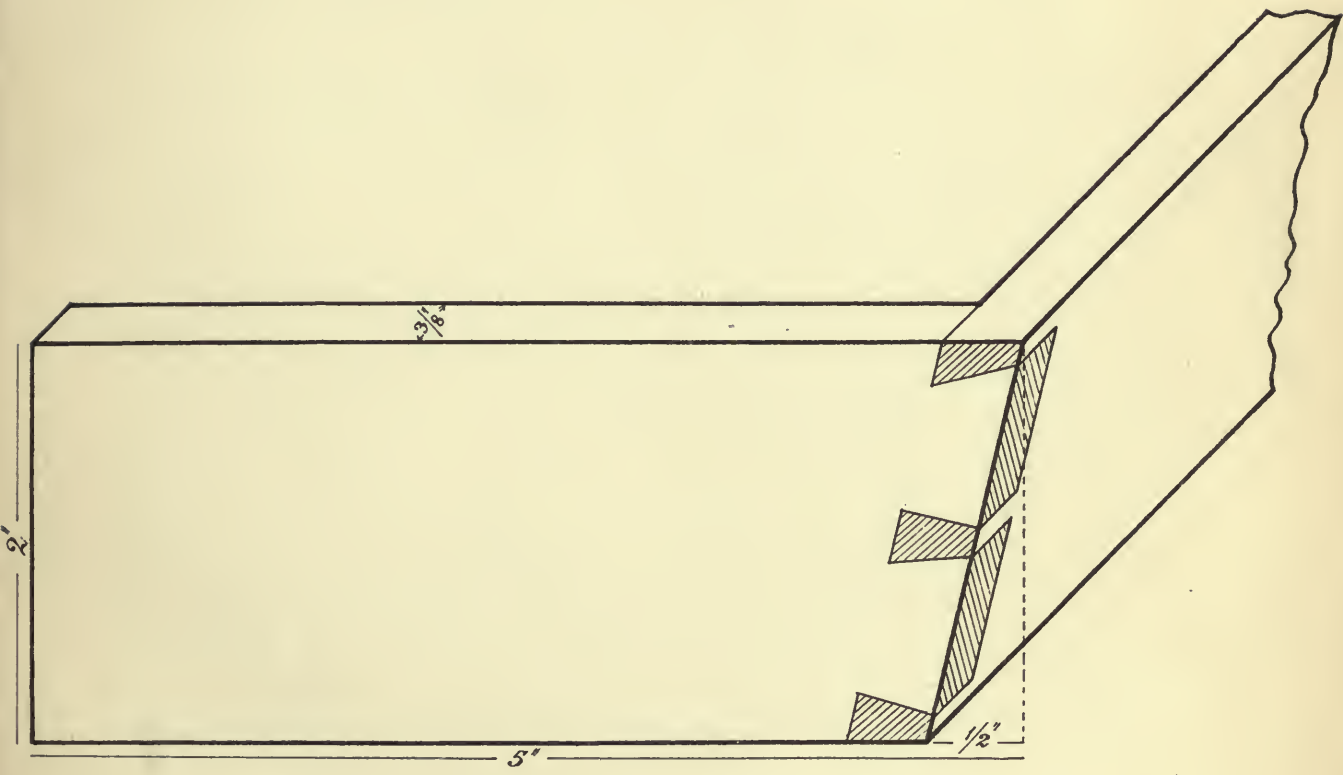

No. 27.—SET SQUARE.

Rough Wood—Birch.— $8\frac{1}{2}$ in. \times 5 in. \times $\frac{1}{4}$ in.

TOOLS.—Jack plane, trying plane, smoothing plane, shooting board, tenon-saw, brace, and centre-bit.

- (1). Plane up a side and edge, and gauge to thickness, and plane off.
- (2). Shoot the end to a right angle.
- (3). Set out the other two angles.
- (4). Saw off with tenon-saw, holding the piece flat down on the bench
- (5). Plane down to the lines carefully, and test the angles.
- (6). Gauge for bevelling, and bevel off.
- (7). Bore the hole.
- (8). Smooth off generally, scrape and sandpaper.

Note.—The piece of rough wood given for this exercise will make two Set Squares, one to the size given, and one at an angle of 45° with $4\frac{1}{4}$ -in. sides. In order that wood may not be wasted, this is recommended.



WOODWORK COURSE FOR BOYS.

No. 27. SET SQUARE. (Full size.)

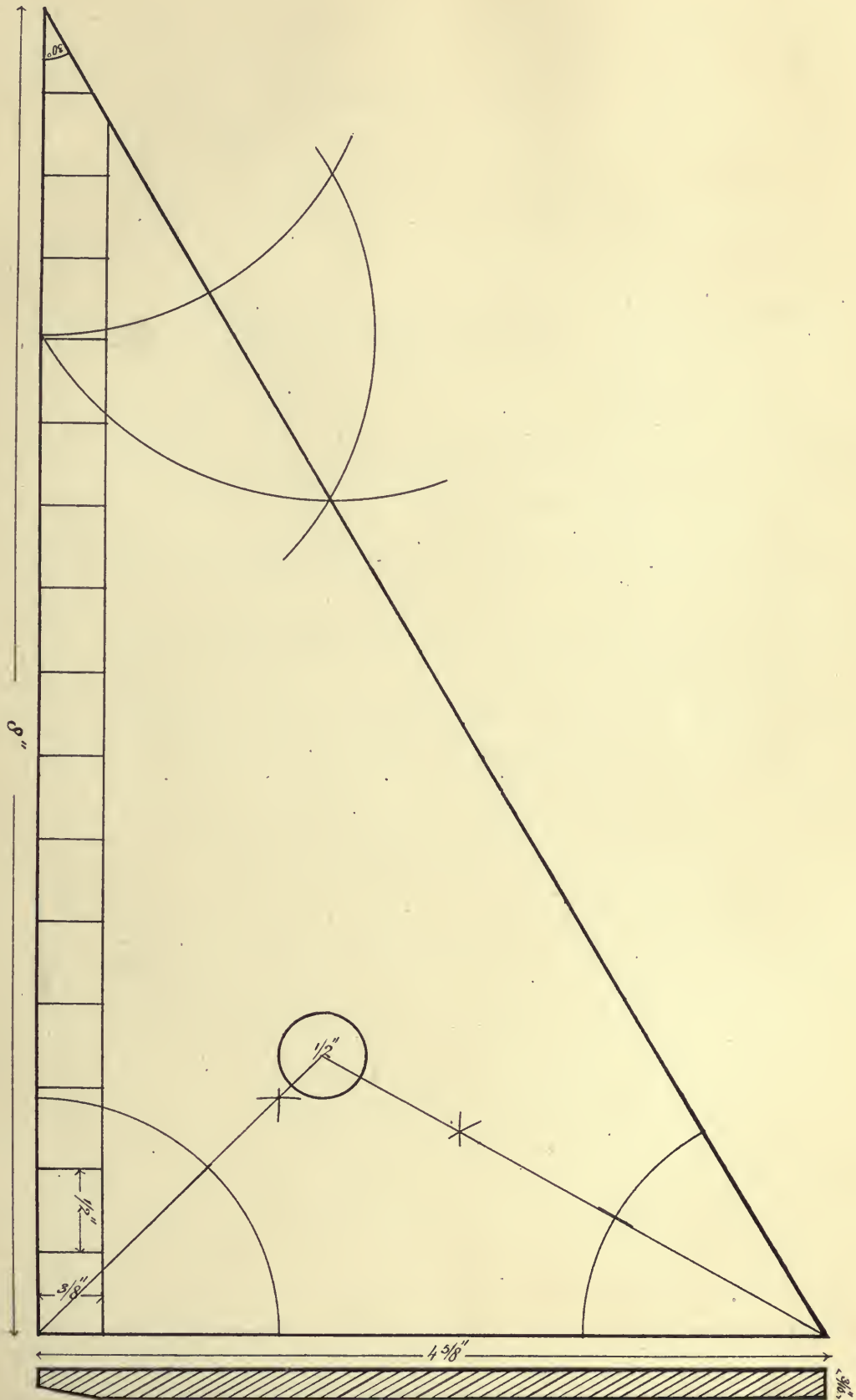

No. 28.—SHOULDERED DOVETAIL.

Rough Wood—Yellow Pine.—11 in. × 2¼ in. × 1 in.

TOOLS.—Jack plane, smoothing plane, shooting board, tenon and dovetail saws, chisels.

- (1). Plane up in one piece.
- (2). Set out for halving with gauge and square.
- (3). Halve the tenon piece, as in Model 6.
- (4). Set out the shape of the dovetail and the shoulders on the tenon piece.
- (5). Cut across for the shoulders with dovetail-saw, and pare the sloped sides with the chisel.
- (6). Now place the tenon on the socket piece in right position, and mark off from it the exact shape and size of the socket.
- (7). Cut the socket out with dovetail-saw and chisels.
- (8). Cut the pieces to length and shoot the ends.
- (9). Put together and smooth off.

Note.—This is a joint used for Tee Squares, and also for some purposes in carpentry.

WOODWORK COURSE FOR BOYS.

No. 28. SHOULDERED DOVETAIL. (Full size.)

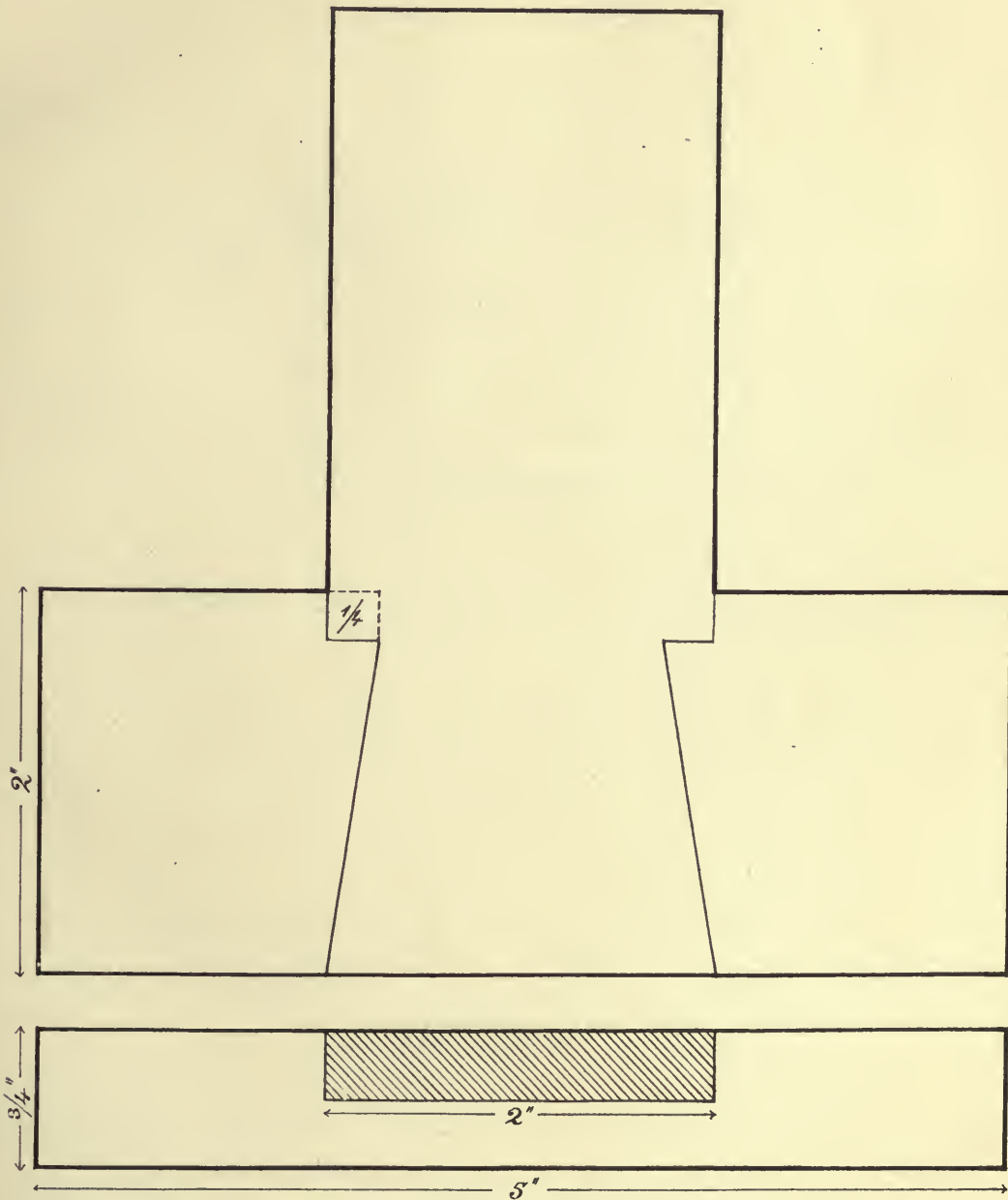

No. 29.—TEE SQUARE.

Rough Wood—Bay Wood.

Blade— $18\frac{1}{2}$ in. \times 2 in. \times $\frac{1}{4}$ in. *Stock*— $8\frac{1}{2}$ in. \times 2 in. \times $\frac{1}{2}$ in.

TOOLS.—Jack plane, trying plane, smoothing plane, dovetail-saw, tenon-saw, chisels, file, scraper, shooting board, and brace and bit.

- (1). **Stock** : Plane up and shoot to length.
- (2). Set out position for the blade.
- (3). **Blade** : Plane up, shooting the edges very carefully.
- (4). Set out the dovetail and the shoulders on the blade.
- (5). Cut out with dovetail-saw and firmer chisel.
- (6). Place the dovetailed end of the piece in proper position on the stock and mark off.
- (7). Cut out the socket with tenon-saw and chisel.
- (8). **Stock** : Round the corners of the stock as shown.
- (9). Smooth off the underside of blade.
- (10). Glue the pieces together.
- (11). Set out the centre for the hole, and bore from both sides with a centre-bit.
- (12). Smooth off, and finish with sandpaper.



WOODWORK COURSE FOR BOYS.

No. 29. TEE SQUARE. ($\frac{3}{4}$ full size.)

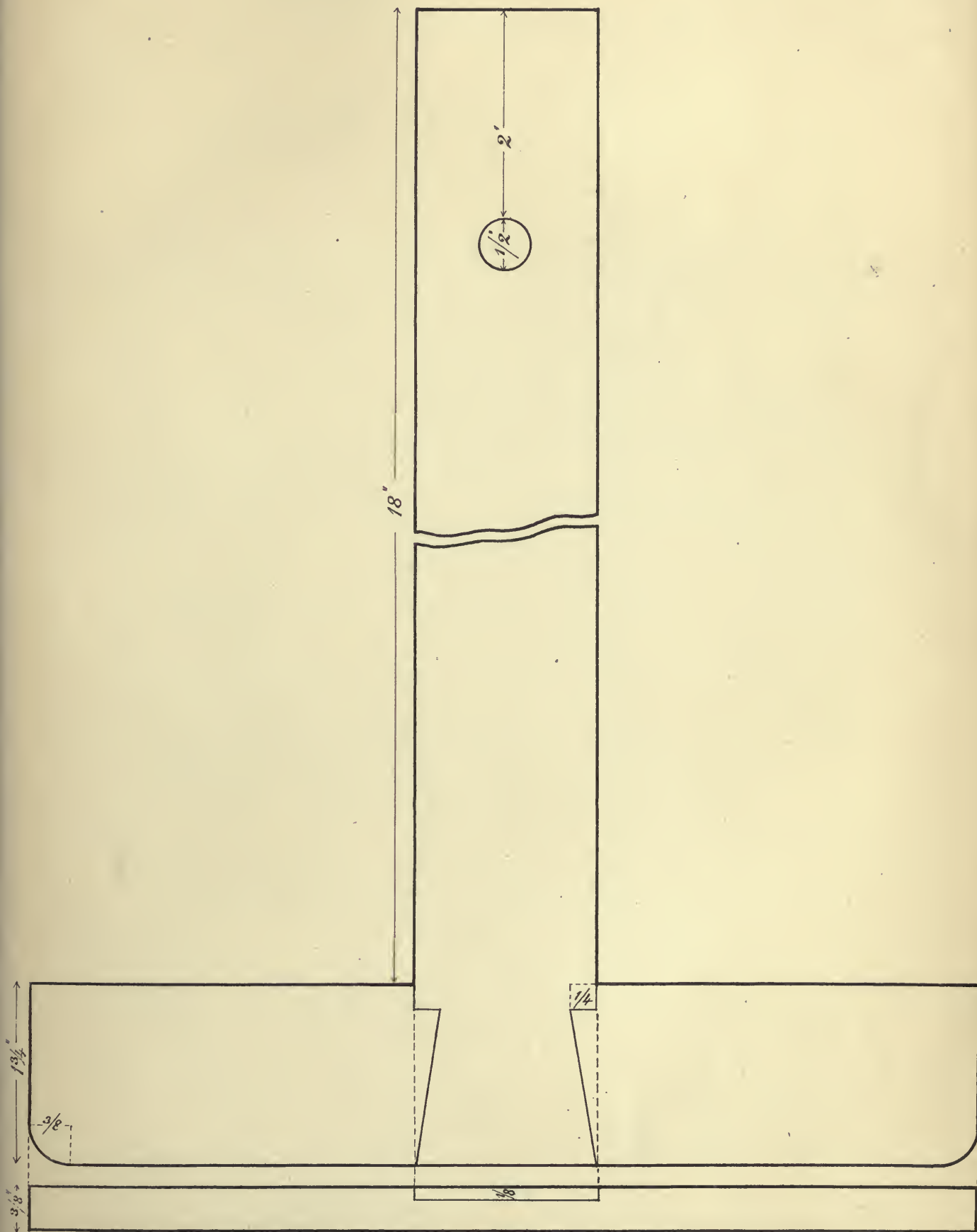

No. 30.—T E A T R A Y .

Rough Wood—Yellow Pine.

Ends—22 in. × 3 in. × $\frac{1}{2}$ in. *Sides*—30 in. × $1\frac{3}{4}$ in. × $\frac{1}{2}$ in.
Bottom—15 in. × $10\frac{1}{2}$ in. × $\frac{1}{2}$ in., in two pieces. *Nails*— $\frac{3}{4}$ in. Oval Steel Nails.

TOOLS.—Jack plane, smoothing plane, trying plane, tenon, dovetail and bow saws, brace and centre-bit, spokeshave, knife, cutting gauge, file, chisels, mallet, bradawl, hammer, punch, shooting board.

- (1). Bottom : make a plain joint and glue.
- (2). Plane up sides and ends to thickness.
- (3). Set the bevel to required inclination of side of tray.
- (4). Bevel off the edges of the sides to this inclination and to right width, as in Model 26.
- (5). Bevel off the lower edges only, of the ends.
- (6). Now cut and shoot the ends and sides to right lengths and angles, as in Model 26.
- (7). Set out for dovetailing, and dovetail as shown in Model 26.
- (8). Draw the shapes of the ends, and cut out as in Model 24, keeping to the special angle of tray (this is important). The top edges of the sides and ends are also slightly rounded, as shown in diagram ; do this with the spokeshave and file.
- (9). Smooth off the inside, and glue together.
- (10). Plane up, and make the bottom, allowing for projection and rounding the edges, as shown.
- (11). Bore the bottom for nailing.
- (12). Smooth up, and sandpaper the outside of the tray.
- (13). Nail the bottom on, and sink the heads of the nails with the punch.
- (14). Smooth off the bottom, and finish generally.

WOODWORK COURSE FOR BOYS.

No. 30. TEA-TRAY. (Full size.)

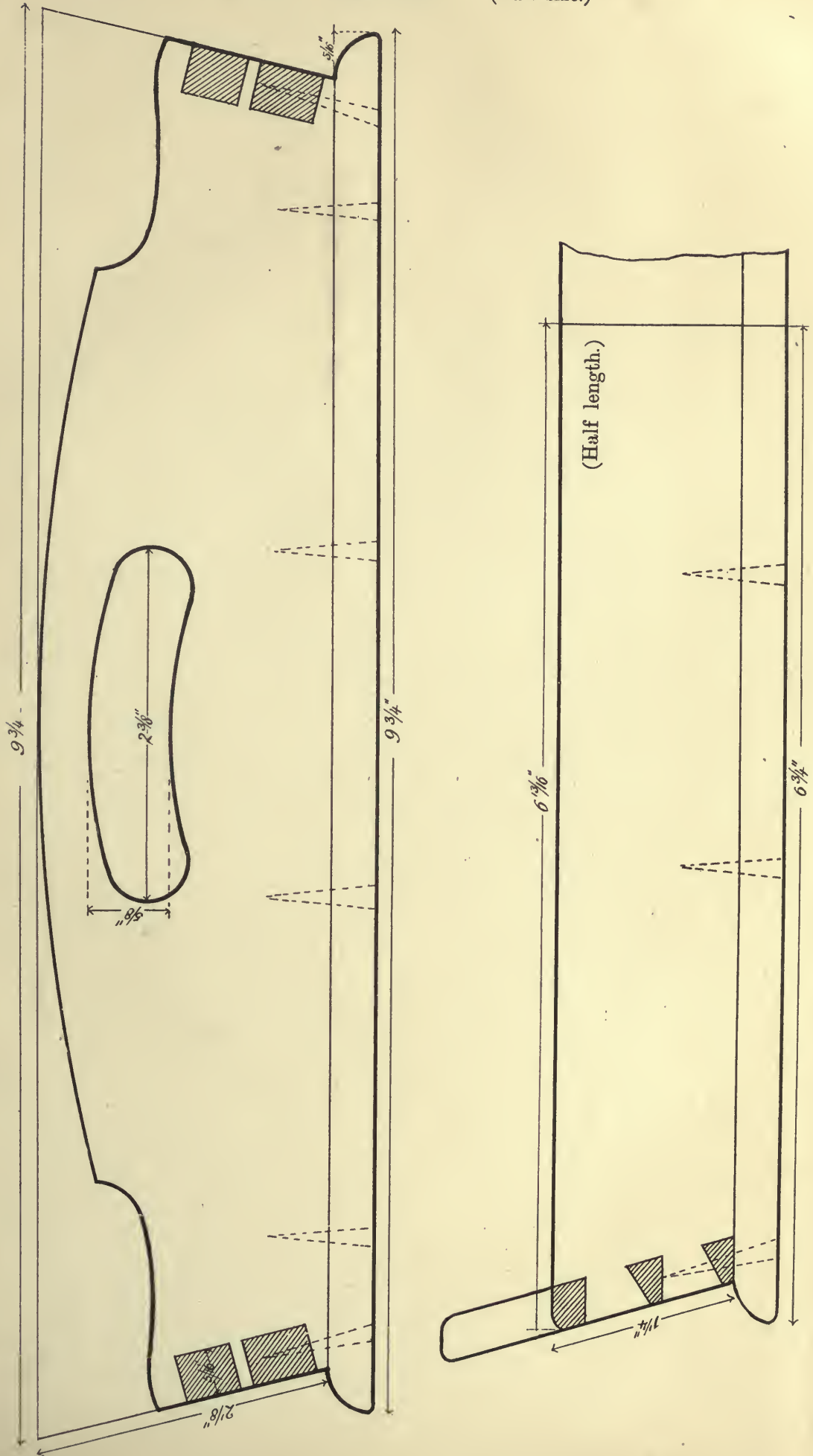

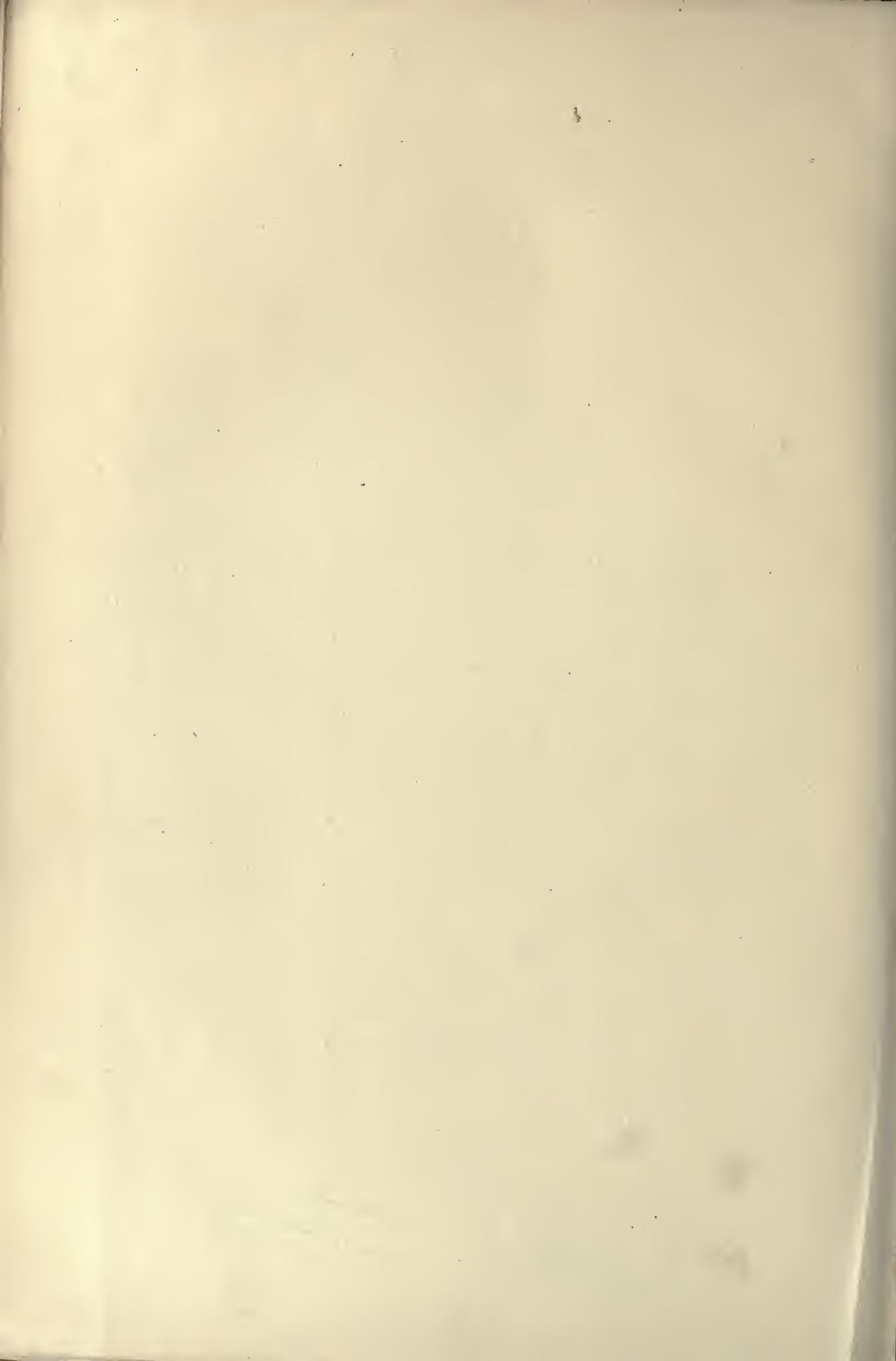

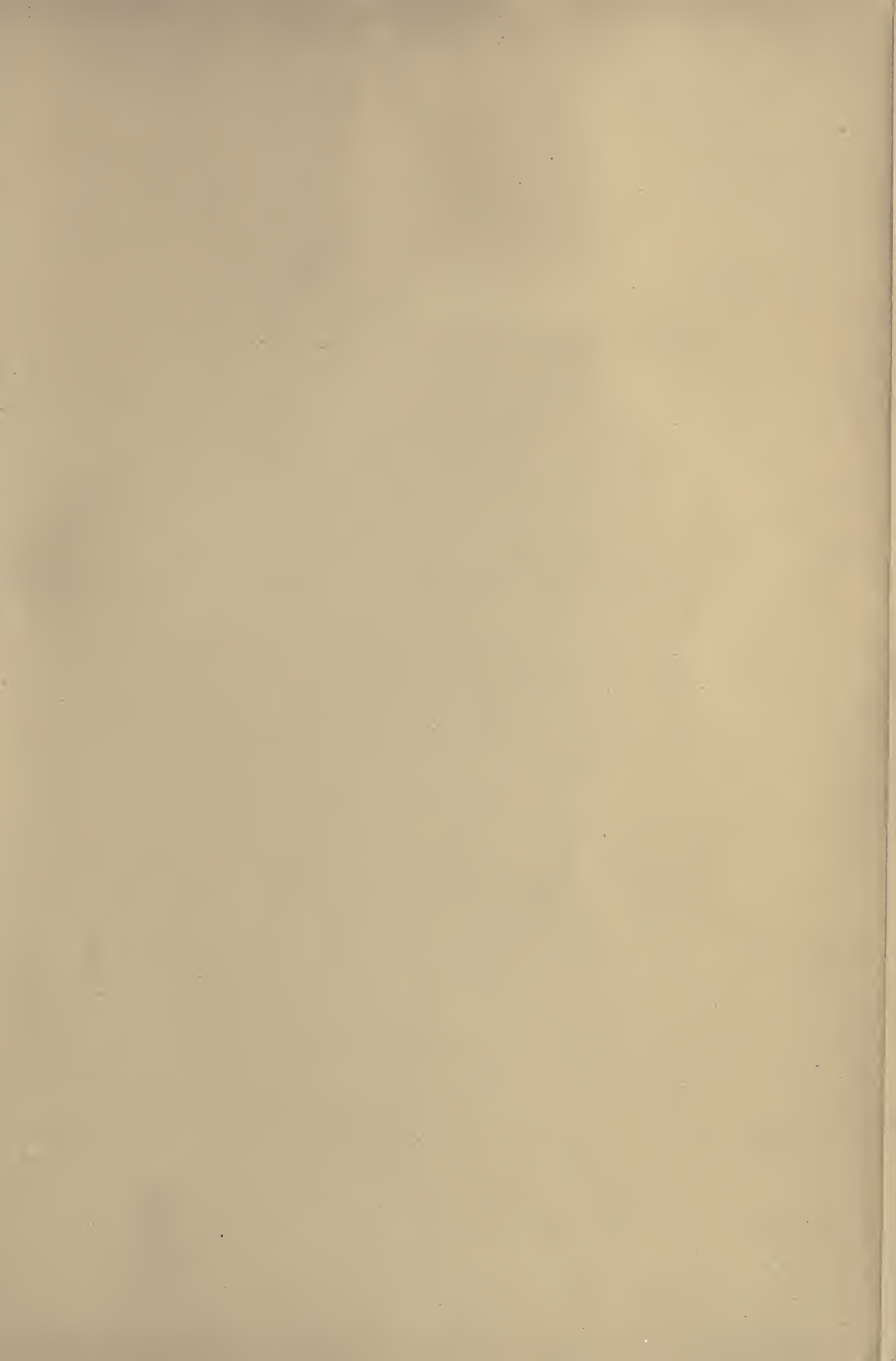

THIS BOOK IS DUE ON THE LAST DATE
STAMPED BELOW

AN INITIAL FINE OF 25 CENTS

WILL BE ASSESSED FOR FAILURE TO RETURN
THIS BOOK ON THE DATE DUE. THE PENALTY
WILL INCREASE TO 50 CENTS ON THE FOURTH
DAY AND TO \$1.00 ON THE SEVENTH DAY
OVERDUE.

AUG 14 1940

LD 21-100m-7,'39(402s)

53789

LB 1599
W6N4

PHILIPS'

TECHNICAL EDUCATION SERIES.

TECHNICAL EDUCATION IN THE COUNTIES: What is it? How may it be carried out? Treating of Agricultural, Mining, Engineering, Night Science and Art Trade School, and Commercial Requirements, with valuable appendices. By C. J. Michell, B.A., and E. P. Smith, A.R.C.Sci. (Lond.) Crown 8vo, price net, 1s.

MANUAL TRAINING.

The Authorised Translations of the Sloyd Handbooks used at Nääs, in Sweden, and published under the auspices of "The Sloyd Association of Great Britain and Ireland."

1. **THE TEACHER'S HANDBOOK OF SLOYD**, containing Explanations and Details of each Exercise. Translated from the Standard Swedish Work of Herr Otto Salomon, the Director of the Nääs Training School, and adapted for English Teachers. By Mary R. Walker and William Nelson. With over 130 illustrations and plates. Demy 8vo, 216 pp., cloth, price 6s.

2. **PRACTICAL DIRECTIONS FOR MAKING THE HIGH SCHOOL SERIES OF SLOYD MODELS**, for the use of Teachers and Private Students. By Alfred Johansson, Teacher at the Slöjd Training College, Nääs, Sweden. Translated and adapted for English Teachers. With a series of alternative models. By Mary R. Walker and William Nelson. Crown 8vo, interleaved, bound in cloth, price 2s.

Just published. Printed on Cards (size 11½ by 7¾ inches). In stout wrapper, with elastic band. Price 3s.

3. **WORKING DIAGRAMS OF THE HIGH SCHOOL SERIES OF SLOYD MODELS**. Drawn to English Measurements, and intended to accompany Johansson's "Practical Directions." By William Nelson, Organizer of Manual Training to the Manchester School Board. The Set consists of detailed Diagrams of all the fifty Models forming the High School Series, together with five additional Diagrams of Alternative Models, specially adapted to English requirements.

4. **THE THEORY OF EDUCATIONAL SLOYD**. The only Authorised Edition of the Lectures of Otto Salomon, Director of the Seminarium for Teachers at Nääs. Revised and Edited for English and American Students by an Inspector of Schools. Together with a Résumé of the History of Manual Training, and a Portrait and Biography of Herr Salomon. Crown 8vo, 164 pages, cloth, price 3s. 6d.

Just published.

5. **WOODWORK COURSE FOR BOYS**. Consisting of a graduated series of Thirty Models, arranged so as to cover the requirements of the Science and Art Department, South Kensington. Containing full-page Working Drawings, and Practical Directions for making each Model. By William Nelson, Organizer of Manual Instruction to the Manchester School Board. Imperial 8vo, boards, price 3s. 6d.

A Complete Set of the Wooden Models, as described in above work, can be had on application through the Publishers. Price £2 10s. per set, net.

The intention of this book is to put into the hands of Teachers a well-tried and thoroughly practical Woodwork Course for Boys in Elementary Schools. It covers the requirements of the Education Department in such a way as to be educational, and, at the same time, interesting. Any Teacher holding the City and Guilds 2nd year certificate in woodwork, or a Sloyd certificate, will be able from the directions given to conduct a class in woodwork in a methodical and satisfactory manner.

LONDON: GEORGE PHILIP & SON, 32, FLEET STREET, E.C.

LIVERPOOL: 45 TO 51, SOUTH CASTLE STREET.