

⊕
AËRIAL
NAVIGATION

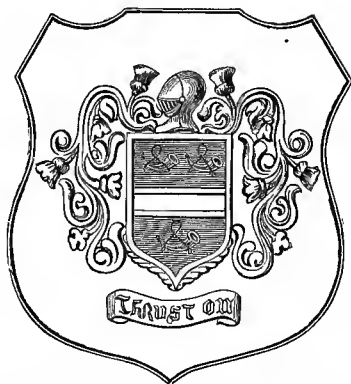

J.G.W. FIJNJE VAN SALVERDA



Robert Henry Thurston

A Gift to
Cornell University Library

1903

Cornell University Library
TL 544.F47

Aërial navigation.



3 1924 022 830 545

oim

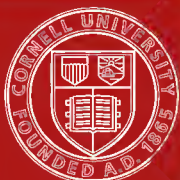

Cornell University Library

The original of this book is in
the Cornell University Library.

There are no known copyright restrictions in
the United States on the use of the text.

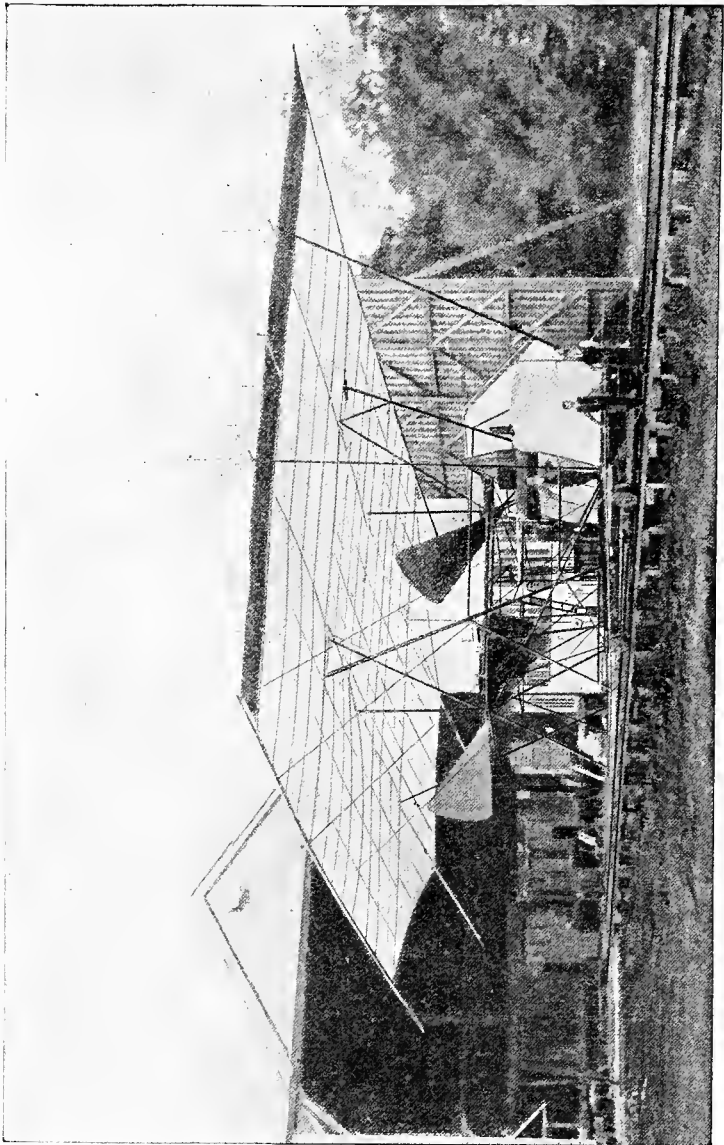

MAXIM'S EXPERIMENTAL MACHINE.

AËRIAL NAVIGATION

BY

J. G. W. FIJNJE VAN SALVERDA

LATE ADMINISTRATOR OF PUBLIC WORKS OF THE
NETHERLANDS, AND ADVISORY COUNCILLOR FOR
HYDROTECHNIC AND RAILWAY AFFAIRS

TRANSLATED FROM THE DUTCH BY

GEORGE E. WARING, JR.

*WITH NOTES CONCERNING SOME RECENT DEVELOPMENTS
IN THE ART*

NEW YORK
D. APPLETON AND COMPANY

1894

COPYRIGHT, 1894,
By D. APPLETON AND COMPANY.

ELECTROTYPED AND PRINTED
AT THE APPLETON PRESS, U. S. A.

NOTE BY THE TRANSLATOR.

THE following pages contain a comprehensive summary, mainly in popular form, of the development of aërial navigation from the balloon of Montgolfier (1783), which was filled with heated air, down to the early stages of the investigations and discussions of Langley, Maxim, Holland, and others (1892).

The writer is a most distinguished Dutch engineer, of advanced age, and now retired from the public service, in which he held the highest position.

The conclusions reached by Mr. Fijnje, after his careful review of the whole field, are entirely in the direction of the early successful solution of the problem of mechanical flight, and his conclusions are well sustained by his evidence.

After the publication of the original essay, Mr. Fijnje learned of the investigations of Prof. S. P. Langley, of the Smithsonian Institution, and of the published essays of Mr. Hiram S. Maxim and Mr. John P. Holland, which constituted an important addition to the material available at the time of his first writing. He thereupon issued a second pamphlet, describing and discussing the

new suggestions as to the application of the aëroplane principle. Copious extracts from this publication are given herein. To bring information as to the progress of the art down to the date of publication, there is presented, in addition to Mr. Fijnje's writings, a *résumé*, with extracts, of Langley's *Experiments in Aërodynamics*, Holland's essay on *Mechanical Flight*, and Langley's later and very important paper on *The Internal Work of the Wind*.

G. E. W., JR.

NEWPORT, R. I., *January*, 1894.

CONTENTS.

CHAPTER	PAGE
I.—INTRODUCTION	1
II.—THE MILITARY IMPORTANCE OF AËRIAL NAVIGATION	10
III.—COMPARISON OF BALLOONS WITH BUOYS USED TO INDICATE SHIP CHANNELS	23
IV.—THE AIR SHIP IN CALM WEATHER, OR IN THE ABSENCE OF WIND	32
V.—THE EXTRANEOUS OBSTACLE, OR THE WIND—ITS RÔLE IN AËRIAL NAVIGATION	40
VI.—PRACTICAL RESULTS ALREADY REACHED IN MACHINERY FOR PROPELLING BALLOONS	52
VII.—EXPERIMENTS WITH THE BALLOON "LA FRANCE" IN THE YEARS 1884 AND 1885	59
VIII.—THE FLIGHT OF BIRDS	64
IX.—THE BOY'S KITE	69
X.—THE ORDINARY FLYING OF BIRDS—"ROWING" FLIGHT	73
XI.—HOVERING FLIGHT	80
XII.—SAILING FLIGHT	89
XIII.—THE LAW OF AVANZINI	94
XIV.—THE EXERTION OF FORCE BY BIRDS	101
XV.—ATMOSPHERIC CURRENTS	104

CHAPTER	PAGE
XVI.—THE APPLICATION OF THE PRINCIPLE “LE PLUS Lourd que l’Air	109
XVII.—CONCLUSION	117
EXTRACTS FROM A LATER PAMPHLET BY MR. FIJNJE	125
PROF. LANGLEY’S EXPERIMENTS	167
STUDY OF A PRACTICAL AIR SHIP	184
THE SOARING OF BIRDS AND OF MEN	201
INDEX	205

AËRIAL NAVIGATION.

CHAPTER I.

INTRODUCTION.

THE important question of aërial navigation has taken on a more and more scientific character, and has enlisted the increasing interest of serious minds. The opinion that a brilliant future is before it is apparent from its very general acceptance among competent experts in France at this time. It is, indeed, slowly, and only within a few years, that it has made real progress. This is to be ascribed in part to recent meteorological observations, and in part to the numerous experiments and photographic observations, with the investigations thereby made possible as to the movements of birds in flying. Such investigations were necessary before the requirements of mechanical flight and the laws controlling it could be properly understood.

The investigation of this question assumed a practical and more especially a military importance during the siege of Paris and in the war of Tonquin. This

military side of the problem seems, in France at least, fully to keep pace with the more purely scientific interest, which has to do with meteorological problems generally.

These various trials have led to broader investigations, which must surely aid in the final solution of the difficult problem. Other enlightened countries of Europe and America have also joined in the inquiry. The more or less uncertain problem as to the use of air balloons is still far from being solved. The difference is indeed great when we compare with the present balloon the simple one which Joseph Montgolfier sent up on the 5th of June, 1783, at Annonay, and by which he and his brother Stephen made themselves famous.* This balloon was made of varnished paper and was filled with heated air. Nevertheless, the reports of

* The credit of the invention of the air balloon by the Montgolfier brothers was not disputed, notwithstanding the fact that already in ancient times mechanical flight had been spoken of. It appears, however, that attention had up to that time been given chiefly to the flight of birds. Reference may be made in this connection to Dædalus and Icarus in Greek mythology; to the natural philosopher Dante in the latter part of the fifteenth century, of whom it was reported that he flew several times across Lake Trasymene in Italy, till in descending too rapidly he broke one of his legs; and finally to the smith of Sable, in France, who with a pair of wings was able to descend obliquely, though he could not lift himself through the air. There are, aside from the foregoing, only traditions as to the air ship of Laurent in 1709, and that of the Jesuit priest Lara; and finally that of the Portuguese, Guzman, of whom it was maintained that he invented an air balloon in 1736.

this apparently unimportant experiment were soon spread throughout Europe, and attracted the universal attention of scientific men. Thereupon Prof. Charles, in conjunction with the brothers Robert, mechanics, filled the first balloon with hydrogen gas. This was only four metres in diameter. It was sent up from the *Champs de Mars* in Paris. Rising with astonishing rapidity, it soon disappeared from sight and burst from the great expansion of the gas in the lighter upper air. It came down about twelve miles from Paris, in the village of Genesse, where it was destroyed with hay-forks and flails by the superstitious peasants.

Five months after the ascension of the air balloon at Annonay the first ascent with passengers was undertaken by Pilatre de Rozier and the Marquis d'Arlande. They went up at the Château "la Mnette," not far from Paris, with a balloon fifteen metres in diameter, and in twenty-five minutes they came down at about five miles' distance from the starting place. This first trial was soon followed by several others,*

* In January, 1885, Dr. R. Joy Jeffries, of Boston, held a private centennial celebration of an achievement of his grandfather, Dr. John Jeffries, a graduate of Harvard University, who made, in 1785, the first passage by balloon from England to France, with the aeronaut Blanchard, paying him over £700 for the cost of the trip. They quitted the cliff at Dover at quarter past one. At three they passed over the French coast between Cape Blancenez and Calais. At quarter past three they descended in the forest of Guines. The spot is still indicated by a monument erected

with such improvements as the safety-valve, the rope net for hanging the car, the use of ballast, the anchor, etc. The idea was then also conceived of determining the elevation by barometrical observations. Prof. Charles and Robert had already reached a height of six hundred metres in a balloon starting from the garden of the Tuileries. When the last named got out, the balloon rose suddenly to a height of three thousand metres, but came down twenty-five minutes later. Gay-Lussac and Biot reached an elevation of four thousand metres, and the first named, alone, an elevation of even seven thousand metres.

The ascent and descent of balloons could, therefore, be more or less completely regulated; there was thus far, however, no suggestion of controlling the direction. The question of the buoyancy of the balloon necessary for the ascent still commanded exclusive attention, with the immediate result of giving a wrong direction to observations and to scientific investigations. This led to constant disappointment, and, strictly speaking, no further progress in the scientific development of aërial navigation was made for nearly a century.

Due account could be taken of the scientific considerations only by the aid of—

by the Municipal Council of the city and Compté of Guines. He was much *fêted*, and a very interesting account of the adventure, taken from his journal, is to be found in the *Magazine of American History*, January, 1885, page 66.—G. E. W., Jr.

1. Observations of meteorological phenomena and conditions which might influence aërial navigation, some of which became possible only after the erection of the Eiffel Tower in Paris.

2. Observations on the flight of birds, whereby the requirements of artificial flight might be determined in accordance with the laws of Nature. These observations became possible only after the development of instantaneous photography.

We could, before that, classify the mechanical work of flight into several kinds of movements, but we could not analyze these nor fully comprehend them. There were, therefore, no sufficient experimental investigations as to the resistance of the air as affecting artificial flight, and for the lack of these requisite means, and of a scientific basis for investigation, the development of the art was thus far impossible. As to the flight of birds, and as to the means of making observations concerning this, we worked in obscure uncertainty. This uncertainty has been removed only in these later years by the self-registering apparatus and the chronometric photography of Prof. E. J. Marey, of Paris. These marked a new era in the study, and as we watch their results we advance more and more towards the practical end of a knowledge of mechanical flight. The problem has already reached a good measure of development in France, or has at least attracted more and more general attention; and though great disappointments have thus far been encountered, we can, on the other hand,

show the important result that balloons have made us, in a certain measure, independent of gravitation ; that we can, with their aid, be for a time borne up in the air, and that within certain limits we can rise and descend. The possibility of moving at all times and in any desired direction is attained only imperfectly, and we have for nearly a century worked in vain towards this end, because of the erroneous supposition that the apparatus must be as light as possible, and that only buoyant balloons can fulfil this condition. Only recently it was proved that the object could never be perfectly attained with balloons, and that in this respect we had simply been following a wrong lead. The means for steering the balloon, which was at first supposed to be an unimportant part of the problem that would soon be solved, seems to require the most investigation and the most exact knowledge. But few had suspected this, and doubt with regard to it was ascribed to great and unaccountable over-anxiety. Yet this doubt was well founded.

Among the bold pioneers who have in modern times prepared the way for a scientific study of the problem, Nadar, of Paris, must be accorded the first rank. Without possessing the varied scientific knowledge requisite for such study—which, in fact, at that time was impossible—he yet arrived, by dint of his own observations and investigations, to the conclusion that the prevailing idea of the necessity of using light balloons was founded in error—a conclusion which was pithily expressed in the

designation of his principle, *Le plus lourd que l'air*. In order to secure acceptance for that principle, it must be followed out and analyzed, which required not only great outlay but the concurrence of men learned in different branches. That point of view had not before been taken, but Nadar became convinced of its necessity by mere force of his exceptional common sense, his immovable equanimity, his inspired enthusiasm, and above all his firm conviction, and he was soon recognized as the most fit person to awaken a general interest in the universal importance of the object in view. He did not spare himself in the always more or less hazardous strife with the powers of the air, and he hesitated even less to make pecuniary sacrifices to his principle, *Le plus lourd que l'air*, though he brought financial trouble on himself thereby. He was always sustained by his placid, gentle, but courageous wife.

Nadar set forth his principle in a pamphlet* entitled *Droit au Vol (The Right to Fly)*. At his own cost he constructed a gigantic balloon, with a capacity of six thousand cubic metres and a height of forty-five metres, trusting therewith to secure the capital, of uncertain amount, which he judged necessary for further exploration. He was fully convinced that his principle could attain general acceptance only after thorough investigation.† It was therefore a great disappointment

* Published by Hetzel, Paris, four editions.

† It should be noted here: (1) That already, in 1837, a Swedish engineer, Tollin, had tried to introduce the principle of *Le*

to him that the financial undertaking of "The Giant" was not a complete success.*

These efforts had only the result of giving his principle an important bearing on later scientific investigations. Beyond this we can attach no great scientific value to these ascents, which, indeed, they were not intended to have. It was always known that the larger the balloon the greater the number of persons that it would support; that account must be taken of the time available and of the state of the weather; and that, still more than in ocean navigation, the regulating and starting of the balloon demands the services of competent and tried experts. In this regard, the choice of times, and especially of the men in control, was not always

plus lourde que l'air and (2) Simultaneously with Nadar, Messrs. la Landelle and De Ponton d'Amecourt, in their studies, had advanced the same principle, which resulted in the association of the three men.

* Nadar made only six ascensions with his balloon, "The Giant," in the years 1864-'67—viz., three times at Paris, once at Brussels, once at Lyons, and once at Amsterdam. Tersteeg joined in the last-named ascent, and wrote a communication concerning it. The balloon was then turned over to a company. The first two ascensions at Paris were made in unfavourable weather; the first time the safety-valve did not close completely, and it became necessary to descend when they had only reached Meaux, five kilometres from Paris; the second time Nadar was accompanied by his wife and by a descendant of Montgolfier. In coming down they were in danger of their lives, for the balloon, driven by a fierce storm, bounded along the ground with heavy shocks. This account is derived from an accurate report which was soon published in somewhat romantic form, entitled *Mémoires du Giant*, with a preface by Babinet, 1 vol., 12mo, Dentu, 1864, two editions.

fortunate. The ascent was therefore sometimes a hazardous undertaking.

The principle *le plus lourd que l'air* has appeared to me, strictly speaking, not to be entirely sound, for the reason that the weight of the whole apparatus, so far as the conditions for ascent are concerned, need not be heavier than the displaced air; it contains, however, an unmistakable element of truth, and has helped to do away with a still existing erroneous idea concerning light balloons. It has also led to the conviction that ability to give any desired direction to the flying machine is absolutely necessary. The direction of the common balloon was entirely dependent on the wind; while the former opinion that the higher strata of the atmosphere moved in an opposite direction, and that advantage could be taken of this fact in the movement of the balloon was not confirmed. The possibility of controlling the direction of air machines has indeed now been established, but thus far only within certain limits; it is dependent on the nature of the apparatus, on the rapidity of its movement, and on the weight of the machinery employed. I shall endeavour, in the following considerations, to establish this opinion by a general review of the present status of the art, without pretending to a thorough knowledge of its fundamental principles nor of all the details of the subject.

This would be too extensive a work, and would be beyond my ability. It must, I think, be relegated to a future time, when a more intimate knowledge of the art of aerial navigation shall have been reached.

CHAPTER II.

THE MILITARY IMPORTANCE OF AËRIAL NAVIGATION.

BEFORE going into the general subject, however, it seems proper to give some attention to the advantages in warfare offered by mechanical flight, which, as has already been observed, has kept pace with the scientific side of the question, and which has led to wider investigation.

We have in view, in this connection, not only the siege of Paris, but also the war in Tonquin and the recent important military manœuvres in France.*

During the siege of Paris the Government was constantly striving to put itself into communication with the departments, and Nadar distinguished himself very greatly in establishing the balloon postal service, rendering his aid in the most disinterested manner; but he had to give way before the extravagant demands as to their personal safety of those employed in the service.

The state of the weather and the barometrical conditions were closely followed day by day, so that the

* See the *Revue du Génie*.

balloons which were sent up came down with much precision. This never failed. As it is not at all my purpose to enter into the political difficulties of the time, I will only say that even Gambetta himself did not hesitate to escape from Paris in a balloon.

In Tonquin the natives offered a stubborn resistance to the French troops under Admiral Courbet. In the low level ground of the delta, that seemed especially designed for rice cultivation, the enemy could deploy *en tirailleur*, and shield himself behind the smallest clump of bamboo plants, so that he was sufficiently protected, while the French were, on the contrary, exposed to a murderous fire. On the first landing of troops at Kelung they were also confronted in the unknown land by important defensive works of whose existence they had no suspicion. In consequence of the defeat experienced, the French Government found itself obliged to send out strong reinforcements under three generals. At the suggestion of Admiral Courbet, these were accompanied by a detail of aëronauts, consisting of Captain Aron, Lieutenant Jullien, five subordinate officers, eight corporals, and twenty-three sappers. These were all familiar with ballooning, while the arsenal at Chalais provided the needed material.*

* In this connection it is to be observed that—(a) The regulation army balloon of six hundred cubic metres could not be transported over the roads then existing in Tonquin, and smaller ones were sent out, which were made in Chalais in less than a fortnight. (b) The hydrogen gas needed for filling the balloon had to be pre-

According to the published accounts these balloons answered their purpose excellently well. They accompanied the troops in all the military operations in Tonquin, and were also used in action. Not to go too much into details, and confining ourselves to our main purpose, we shall not describe the expeditions and battles, but confine our remarks to some individual instances. One of the balloons, after being used uninterruptedly for thirteen days, was still in sufficiently good condition to allow one observer to make the ascent.

The outfit had sometimes to be conveyed over simple footpaths, and always over obstructed roads. By reason of the existence of unusually large bamboo plantations, which it was necessary to avoid, they had constantly to go through the flooded rice fields. The day's march thus became very difficult, and sometimes, during strong winds, the men had to tug at the ropes with all their might. No delay was, however, experienced from this source.

The observations were sometimes made during more or less wind. The balloon then rose to an average height of one hundred and fifty metres, and during

pared on the ground. (e) It was feared that the varnished balloons would be injured during the transit through the Red Sea. They were therefore loaded not in the hold but on the bridge, near the pilot-house, after being well oiled and covered on the seams with oiled paper. These balloons were not injured in transportation at all, in comparison with those that were left to be varnished on the spot.

battles to two hundred and fifty metres. From that height, by raising the voice, it was possible to inform the commanding officer as to the point where the projectiles fell, and as to the strength of the force to be attacked. The commanders acted in accordance with these indications, and thus maintained the courage of the army in a remarkable manner.

Communications for the chief of staff were written on paper, which was weighted with stones that they might easily be found; these were forwarded immediately by mounted couriers.

It was also through the exact reconnoitring of the aërial observers that the Chinese were prevented from retiring from Bac-Ninh; and that place was taken without assault and without firing a shot.

It has therefore occurred to me that a close study of the war of Tonquin in 1884, with an eye to the possible uses of aërial navigation, must be considered as full of importance to the art of war.

Concerning the use of aërial navigation in the recent great military manœuvres in France, we take the following account from the report of M. Debureaux, an officer of engineers, which appeared in the *Revue du Génie*.

According to this officer, the military value of aërial navigation was never so decisively shown as in the manœuvres in the Department of the Aube. Anchored balloons were in telephonic communication with the ground, and the great importance of this novelty was

fully appreciated. Instead of being obliged to draw the balloon down in order to receive the information that had been gathered, the officers in the car were in constant communication with the commanding general, and could keep him always informed of the least movement of the enemy, even those made at a considerable distance.

The advantages derived were not indeed limited to this. With the new means for making the gas, and with the improved method for filling the balloon, they were able to make the ascent within an hour, and could transport the balloon, whether filled or not, with the required aërostatic material without the least difficulty. This material was moved from Versailles to Brienne, more than one hundred and twenty miles distant, in ten days' march. They sometimes made more than twenty-five miles in a single day. It was found in practice, however, that the regulation number of men was not sufficient, and that the party was exposed to much too great fatigue, so that their number was more than doubled.

The first ascent was made in rain and wind, and under generally difficult and uncomfortable conditions, at the battle of Aulnay.

The aërostatic park had to be conveyed to Garenne, the place fixed for the ascent, over hilly and muddy roads. In spite of these difficulties, however, the ascent was made at the appointed hour, and great service was rendered. Warning was immediately given to the com-

mander of the Eighth Army Corps that he was moving his lines against a mere feint, and the position of the reserve and the real line of attack were pointed out to him. Thereupon four general officers got into the balloon to profit by the most important advantages that the position offered.

General Galiffet, at Colombey, remained two hours and a half in the car, and from there, at an elevation of from two hundred and fifty to four hundred metres, gave his orders by telephone. The army then covered a field eight miles long by from two to six miles wide. The commander of the Western army was, nevertheless, enabled closely to follow the movements made by the enemy in preparation for the battle; he could clearly distinguish all objects and thus decide how to place his artillery. He could study the country for a distance of twelve miles as on a map, and from the rising dust could follow the movement of troops concealed by woods. After leaving the balloon, this general remained in constant communication with the observers.

At Vendevre, the cavalry fight, more than nine miles distant, was signalled to General Davoust. During the night engagement on the Voire the balloon showed itself to be most serviceable. On the other hand, it was thought at Margeris that it was not best to risk the outfit during the stormy weather. In actual war this consideration would not be allowed to have weight.

The transportation of the filled balloon was most successful, even in the midst of a fight and in spite of the crowding of the troops at the passing of Bar-sur-Aube; in the march through the forest of Bassicin and the Great Eastern Woods, there was, in like manner, no disturbance of the movement of the troops. Every obstacle was overcome in from two to five minutes, while the balloon could always be brought at a trot with great precision and at any moment to its place in the column.

The last trial was at a review of the troops at Vitry. The balloon was sent up after the aërostatic park had been moved into its place, and hovered at a height of six hundred metres over the magnificent display afforded by an army of one hundred thousand men on the march.

In concluding his report, M. Debureaux observes that, had Napoleon at Waterloo and Bazaine at Saint Privat had a balloon service at their disposal, a different result might have been expected from both of these battles; the approach of Blücher in the first place, and in the latter the small force of the Germans, would have been known.

M. Debureaux thinks also that at a distance of three miles the balloon would have been beyond the reach of artillery, and that it would have commanded the ground for a distance of more than six miles. Even at night the country is sufficiently illuminated to be compared with a map. He commends also the ability to transport the balloons over routes which are removed from

the immediate scene of action, and is further of the opinion that, by reason of the facility with which they may be transported, they may be placed beyond the reach of fire, their information being communicated by telephone. The balloon may soon be of great service in sieges, for it can be flown quite over the invested place and descend beyond the reach of danger, reporting to the besieging army what is going on in the town.

From the experience obtained by the ascent at Vitry, such an expedition may be made with a loss of only three hundred and fifty pounds of ballast.

Finally, it is to be expected that with a portable outfit a buoyant balloon can be brought into use within half an hour of the arrival of the aërostatic park, and the foregoing account shows what services can be rendered. In the Netherlands, so far as I know, aërial navigation has engaged attention only from a military standpoint. At Utrecht experiments have been made with a balloon constructed after an old model which cost ten thousand florins, each trial costing seventy florins.

The conclusions reached were, that it was difficult in a covered or wooded country to distinguish the movement of troops and to learn their purpose. As will be shown later, the experience at Atjeh was of a similar character.

The possibility of applying aërial navigation to military ends was thus also realized in our own country, but its technical development had not been sufficiently

advanced for its place in the make-up of the army and in measures of defence to be definitely indicated. It was also thought that, in view of its great cost, its immediate development would not be justified while so many things, which in the opinion of experts were more necessary as means for our defence, must be provided, and which, for lack of means, still remain wanting.

The Military Department, which appreciated the importance of the subject in the Netherlands, was familiar with the work at Chalais, and with the establishment of the balloon service in the French, German, and Austrian armies. There was even prepared a plan for an organization of the service, according to which the cost of the plant with eight balloons amounted to three hundred thousand florins, while it was estimated that for their proper service there would be required nine officers, sixteen non-commissioned officers, and four men; and for the transportation of the park, ten sergeants, ten corporals, sixty-eight riders, and one hundred and sixty-eight horses; and for the service of the arsenal, one engineer, one stoker, three labourers, one mechanic, one tailor, and one sail-maker.

The cost would thus not be unimportant; it seems to justify the fear that such an addition to the military budget would not be acceptable to the States-General. It would seem judicious to leave these costly experiments to the great powers, and to let smaller states ultimately make use of their results. We should, how-

ever, keep ourselves constantly informed as to the latest development of the art, whether at Chalais and in the French army or elsewhere, in order at least to be prepared for a time of better financial conditions. We should not let our thrift get the better of our wisdom. We should keep to the idea of establishing a balloon service at least for the protection of the necessary force, against the time of need, and it is not advisable to postpone this until the emergency arises—not to await the threat of war.

The thought suggests itself that when, before Atjeh, we were seeking in every direction for the means of success, how much better the situation would have been there had we appreciated the value of exact reconnaissance by means of anchored balloons; and, on the other hand also, that the utility of balloons was not at all realized in Atjeh, because the position of the enemy's front stretched along the fortifications and was thickly overgrown with cocoa-trees, or lay in other covered ground. It was thought that even if the balloon should have reached the required elevation, nothing could be seen but a mass of tree-tops, under which the movements of the enemy would remain concealed.

Nevertheless, a foreigner, probably an Englishman, undertook to make observations. He was, however, not successful in his undertaking. His balloon met with a collision at the first trial, and thus soon became unserviceable. It was repaired after much trouble and delay, encountering difficulties for a time, but finally it

was possible to send it up. When it had risen to a certain height, they saw under them a mass of verdant islands, among which the enemy had taken up his position.

As a matter of fact, nothing could be seen of the enemy himself, so that the experiment with the anchored balloon was considered a failure and its use was discontinued. Had they not become discouraged, and had means been found in Atjeh to keep the balloon in good condition, the experiment would probably have been carried to a better result. Still, it was generally considered that it was not possible to observe much through the green foliage, and, for this reason, little practical utility was expected from ballooning in Atjeh. I do not consider myself competent to dispute this opinion. I therefore allow myself only to suggest the question whether this impediment could not have been removed by the burning or the cutting of the wood, at least in part, and whether it also existed in the case of the coast blockade. After the recent great military manœuvres in France, in which the reconnoissance was so complete and covered such distances, it seems to me that there can at least be no doubt as to the utility of balloons for military purposes in the Netherlands and in India, nor that this utility will increase with advances in the science.

Still, however this may be, the difficulty if not the impossibility of distinguishing an enemy scattered under cocoa trees or other wood cannot be denied, and the

difficulty cannot be considered slight. I should not, however, venture to maintain that if the trial had been made with suitable apparatus in place of an imperfect balloon, and with well-trained men, no better result would have been reached. It may very well be that, under the conditions existing, it would have been better not to make the trial at all. This opinion seems to be confirmed by the results obtained in Tonquin. It should be remembered, also, that the conditions of the ground differed too widely for a positive opinion concerning this case to be expressed, and I am bound to defer to the opinion of those who are more competent.

Indeed, if aërial navigation is to become generally possible in the future, we must learn to take exact account of the various situations and conditions under which it is to be effected. These differ materially from those encountered in navigating the water, where obstacles of no less importance had to be contended with. Yet we can now look back on those obstacles with complacency, for they have been slowly and more and more completely overcome, and the same may be assumed in the case of mechanical flight. Without underrating in the least the great services of so many who had already aided more or less in the solution of the important problems, it seems to me that Commandant Renard followed out the difficulties and the requirements of the art in the most exact way. By his analytical development of the principles upon which mechanical

flight must depend, he gave practical form to his observations, on which others can base further investigations and experiments. We shall, therefore, in the following observations, make use of his communications.*

* *La Navigation Aérienne*, par M. le Commandant Renard : *Revue de l'Aéronautique, Théorique et Appliquée*, Première Année, 1888, Paris, G. Masson, éditeur, Boulevard Saint-Germain, 120.

CHAPTER III.

COMPARISON OF BALLOONS WITH BUOYS USED TO INDICATE SHIP CHANNELS.

IN the effort to set forth the conditions under which aërial navigation must take place, the first air balloons of Montgolfier have frequently and not altogether improperly been compared with harbour and river buoys—a comparison which is, to a certain extent, reasonable. Both objects may be regarded as floating, inert bodies, which follow the impulse of the changing current. The resemblance is, however, limited to this condition. The buoy, if carefully constructed, floats in the water for an unlimited time, while the balloon, on the other hand, cannot maintain its position in the air and continue to float without the constant intervention of the aëronaut.

The comparison is, therefore, justified only if we conceive of an anchored buoy floating entirely submerged beneath the surface and rising or falling in the water under the least accidental impulse. To transform an air buoy into an air ship or balloon, its constant stability must be assured. This is, in the first place, im-

possible, and, in order to form a correct idea concerning it, it is necessary to suppose a buoy not floating on the surface of the water, but so ballasted that its own weight is the same as that of the water which it displaces. Were it, under these conditions of equilibrium, placed at a sufficient depth in the water, it would maintain its position without the least tendency to rise or to sink. When, however, by the accumulation of barnacles or other matters, or in consequence of other incidental causes, its weight increases and becomes greater than that of the displaced water, then will the buoy slowly settle to the bottom. The density of the water, which is practically incompressible, is about the same at all depths, so that the weight of the displaced water will hardly increase as the buoy sinks. Should the weight of the buoy become in any way lessened, then, by the same token, it would rise to the surface, while it can have no stable position when entirely surrounded by water. This instability of a completely submerged object was always a difficulty in the case of submarine vessels, which are constantly exposed to the danger of going to the bottom of the ocean in response to an increase of their weight from any cause. In this connection the movement of fishes is worthy of attention. These are perfectly provided with means for overcoming this instability, and maintaining any desired position by the unconscious use of effective mechanical means.

By imitating the methods of fish, submarine vessels have recently been made relatively stable, but they are

still far from satisfactory, and they are not at all to be compared with the strongly driven ships which sail over every sea. Had we thus far brought into use only submarine vessels, navigation would probably still be in the first stages of its development. A similar difficulty will be experienced in aërial navigation, because air ships and the means provided for their propulsion are completely immersed in the fluid air. Just as the submarine vessel moves in the water, so must the balloon move in the atmosphere; both are subject to the same conditions of instability.

The properties of the two fluids, water and air, are in fact very different. Air is not, like water, incompressible, so that its density, and consequently its specific gravity, decrease with the elevation, and its original buoyant force, however great it may have been, ceases and disappears at a certain height, or rather is there in equilibrium with the balloon. Therefore, at this elevation, the balloon is brought to a standstill, but on any accidental increase of weight it falls far enough to bring it again into equilibrium with the displaced air.

This condition appears to be indisputable, and indeed must be so were the balloon air-tight, and made, for example, of steel plates, so that its volume would remain the same at all elevations. This, however, is not the actual condition. The envelope must be opened on the under side, for without this precaution the rising balloon must burst as it passes into air of less and

less pressure, and the confined gas expands in consequence.*

A balloon of constant weight or volume, and capable of maintaining a fixed position, is therefore impracticable. We must, on the contrary, consider it as a bag filled, or partly filled, with gas, and which will yield freely to the changes of volume of this gas as it contracts in falling or expands in rising. Or that by the use of a very sensitive safety-valve the gas will be allowed to escape freely. This last precaution is imperatively needed when the balloon, originally relaxed, has become entirely full, and further expansion has become impossible.

Disregarding the condition just named, and taking account only of the state of equilibrium which must exist whenever a balloon, under ordinary circumstances, is not entirely filled, and is free to expand and contract, then the pressure of the outer air and that of the gas remain the same, and both constantly maintain equal density.

Let us suppose further, for the sake of simplicity, that the partly filled balloon contains one kilogramme of ordinary commercial hydrogen gas, the weight of which bears to that of the atmosphere the proportion of

* It is estimated that a common silk balloon, with a diameter of ten metres, completely filled with hydrogen gas at the level of the sea and tightly closed, will burst at a height of four to five hundred metres, and that to reach this elevation it is necessary to reduce the ballast by sixty or seventy pounds.

1 to $6\frac{1}{2}$. Then, so long as the balloon is not fully distended, this quantity of gas will always, at any elevation, displace 6·5 kilogrammes of air; therefore the result must be, according to the law of Archimedes, that the balloon will tend to rise with a force of 5·5 kilogrammes, according with the difference in weight of the displaced air and that of the gas.

This force is independent of the elevation reached. A balloon so provided with ballast as to be in equilibrium at a given height will therefore, below this height, be under the same conditions with a buoy submerged in the ocean, and thus, on any escape of gas or discharge of ballast, must rise or fall. This shows how difficult it is to convert such a constantly vacillating object into an air ship.*

* The instability of the partly filled balloon can be thus illustrated: Suppose that one cubic metre of ordinary hydrogen gas be introduced into a balloon of several metres' capacity at the level of the sea, and that we may disregard the relatively slight weight of the envelope. The weight of this one cubic metre of gas is 0·2, and that of the air 1·3 kilogramme; the difference of 1·1 kilogramme constitutes the lifting force of one cubic metre of gas at the level of the sea; this is, therefore, the lifting force of the balloon. Now, let this balloon reach an elevation of fifty-five hundred metres—that is to say, the zone where the pressure of the air is reduced one half—then, according to the law of Mariotte, (a) the volume of the gas is doubled, and amounts to two cubic metres; (b) the specific gravity of the air is reduced to one half, and so amounts for 1 cubic metre to $\frac{1}{2} \times 1\cdot3$ kilogr., or 0·65 that of the gas, also reduced to $\frac{1}{2}$, being $\frac{1}{2} \times 0\cdot20$ kilogr., or $\frac{0\cdot10}{2}$ so that the lifting force per cubic metre is reduced to . . . 0·55 or one half of its value at the sea level.

We have therefore, at this height, twice the original volume

When an imperfectly filled balloon rises and its gas expands, it becomes first completely filled and then a portion of its contents escapes through the safety-valve, and the weight of the gas contained in the balloon grows less with the necessary result of an increase of buoyancy, which is in a constant relation to the weight (5·5 times with ordinary gas). The balloon thereby becomes restricted in its movement and soon comes to a standstill. For a correct conception of this supposition, it is to be understood that it is not the weight but the volume of the balloon that remains the same, and that for the sake of simplicity it is assumed to have been filled with one cubic metre of hydrogen gas. The weight of this one cubic metre of gas at the sea level is equal to 0·2 kilogramme, and that of one cubic metre of air to 1·3 kilogramme; so that the lifting force of each cubic metre of gas at this level is equal to $1·3 - 0·2 = 1·1$ kilogramme. After the rising of such a balloon to a height of fifty-five hundred metres, the weight of the air and of the gas is only one half of their weight at the sea level, and consequently their difference of lifting force is correspondingly diminished at this height: $1·1 - 2 = 0·55$ kilogramme. Were the balloon, therefore, so ballasted that its lifting force at the

of gas; but each cubic metre has one half of the original lifting power, so that the whole force remains the same.

This illustration is applicable to all heights, whenever the balloon is not entirely filled and the gas in the envelope can swell or shrink.

sea level was only 0·55, then this force would be exhausted at the elevation of fifty-five hundred metres, and the balloon would there come to a standstill. In other words: it would there have reached its zone of equilibrium, and in general if a balloon filled at the sea level has one tenth; two tenths, three tenths, etc., of its lifting force discharged, it will reach the level where the atmospheric pressure is reduced by one tenth, two tenths, three tenths, etc. The elevations above the sea that will be reached by a balloon of one thousand cubic metres' capacity by such reduction of ballast are given in the following table:

Weight of the discharged ballast, kilogrammes.	Pressure of the air, the pressure at the sea level being the unit.	Corresponding elevation, metres.	Remarks.
0	1·0	0	The third column shows the height which a balloon of 1,000 cubic metres capacity, filled with common gas, would reach with the discharge of the amount of ballast given in the first column. There may be average variations of 50 metres, due to difference of atmospheric pressure.
110	0·9	800	
220	0·8	1,800	
330	0·7	2,900	
440	0·6	4,100	
550	0·5	5,500	
660	0·4	7,300	
770	0·3	9,600	
880	0·2	12,800	
990	0·1	18,300	
1,100	0·0	Uncertain.	

The rising of a full balloon will be, as shown in this table, in proportion to its decrease in weight, and the zones of equilibrium will be as shown in the third column. Between these zones of equilibrium and the earth the balloon is necessarily relaxed and conse-

quently unstable, so that by the least increase of weight it would sink to the earth, and by the least decrease of weight would rise to its zone of equilibrium.

This increase and decrease of weight occur constantly during the flight of the balloon. The force of the sun's rays, dampness caused by rain, snow, hail, etc., clouds, the unavoidable escape of gas, and many other causes, constantly disturb the delicate equipoise of the balloon, which can be maintained at a given height only by the constant intervention of the aëronaut.

As to the means by which this end is to be secured, we do not yet know the first principles. Still, there are means always available to counteract these accidental variations of the buoyancy of the balloon, as by throwing out ballast and letting a certain quantity of gas escape. However complete these means may be, they have the great drawback that the ballast is soon exhausted, and the balloon, weakened by loss of gas, can only settle lower and lower down as local causes present themselves which increase its weight. This explains the short duration of the flight in the air, and equally of ascents made with completely impervious balloons.

The balloon cannot, therefore, be compared in any way with a vessel floating on the water. It is rather an unstable buoy, which, even if its movements could be controlled, could not be of much service, because it can remain only a few hours afloat.

That we are now, however, becoming more and

more capable of coping with this difficulty, and that we shall be able completely to overcome it, cannot in the least be doubted. We already have at command powerful motors of little weight, and we need only combine these with propellers in order to create a strong movement in ascending or descending. It is only necessary for the aëronaut to give the proper direction in order to keep his apparatus in equilibrium. It seems as though accidental variations of buoyancy had already been completely provided against. These means, however, did not exist at the time of the invention of the balloon, and this of itself was enough to render fruitless every effort of the aëronauts to steer their balloons or to maintain their equilibrium; and though this may now be considered quite possible, there are still difficulties connected with it which are not to be foreseen.

CHAPTER IV.

THE AIR SHIP IN CALM WEATHER, OR IN THE ABSENCE OF WIND.

WE have thus far considered the balloon only as a floating mass, whose form has not been taken into the account. This is no longer sufficient. In place of the spherical "buoy," which is familiar to all, we now have the various forms indicated by the terms "air ship" or "flying machine," which are provided with motive power and with means of propulsion, such as a screw or oars. In order clearly to understand the conditions, let us suppose that the air above the earth is completely motionless, or without wind. From this simple condition we shall be able to go on to those of greater complexity.

In this air ocean suppose there to be placed a floating machine in complete equilibrium, and controlled by a strong oarsman with two light oars shaped like rackets. These will be so handled that the stroke is made with the broad side toward the air and the return with the edge, in order that the forward movement may not be retarded by the return stroke. This return must produce the same phenomenon that is pro-

duced in the water, and even a spherical balloon must yield more or less to the efforts of the oarsman. It is clear, however, that it will move more rapidly if it is given the elongated form of a boat or a fish, and that the shape of the common balloon is the most unfavourable. Hence the more recent adoption of elongated constructions in the classic form of a fish or a cigar.

It is to be noted, in this connection, that very soon after the first appearance of the balloon this elongated form was tried, and that attention was then given to its steering. We shall here, in the main, adopt this form, and assume accordingly a cigar-shaped flying machine with a car furnished with a propeller or with a crew of oarsmen. On the operation of these propellers or oars the whole apparatus must move forward like a boat. If also provided with a rudder, it may be turned in any direction and carried to any elevation above the earth, because it is assumed that the air is in a condition of rest, and the ship is therefore floating in an air ocean in which all movement is arrested.

The theory of aërial navigation is in this case a simple one, as it is sufficient for the direction of the balloon that its form should be elongated and that it should have a rudder. Furthermore, the oarsmen might be replaced by some kind of motive power by which greater force may be applied without a change of weight, and greater speed secured without the necessity of modifying the ordinary operation of the system. The speed that may be attained in a calm ap-

pears, according to computation and experiment, to be less than that which ordinary boats have indicated as possible. It is true that in recent trials with the flying machines at Chalais (Mendon) a speed was reached of 6·5 metres per second—equal to about fourteen miles per hour—but this required a much higher power than would be applied to an ordinary boat of the same size.

However this may be, the great question might be considered to be solved by this speed, if only the condition could be granted that the air above the earth should remain without movement. This, however, is not possible, and the great difficulty of the problem is due to the resistance of the wind. We shall recur to this later, confining ourselves for the present to indicating the inherent difficulties peculiar to this form of balloons, which are really formidable, and which nearly caused the death of Henri Giffard. This difficulty results from a tendency of the balloon to swing from end to end because of its elongated form. It is very different from the instability already referred to, which causes balloons of all forms constantly to rise and fall. It is the inclination to swing or pitch from front to rear, very much as a ship heaves.

This peculiarity is called *longitudinal instability*.

In order to understand this, let us assume, with Dupuy de Lôme, that the balloon, after having reached its zone of equilibrium, has fallen a little, and as a consequence its content of gas has contracted, and that the envelope has consequently become somewhat relaxed.

From this moment, as soon as it inclines a little forward, the gas, following its tendency to rise, moves toward the rear end and increases its elevation, so that the inclination is increased. If the person in charge now attempts by any means to restore the proper position, and goes a little beyond the mark, the gas will move more or less suddenly to the front, and the balloon will slope in the opposite direction. In 1855 such an elongated balloon, in which Henri Giffard was descending, pitched to such a degree that, as it reached the ground, it broke loose from its net with such force that it burst, and fell at some distance in two separate parts. Thus we see that even in calm weather we have to contend with a difficulty which may attach to propelled balloons, and which the early experimenters could not suspect. Recognizing this difficulty, however, Dupuy de Lôme was, by his observations and experiments, enabled to overcome it with the modern balloon of slight elongation.

The means applied by this excellent engineer were of two kinds: The first lay in maintaining a constant extension of the envelope by introducing air in proportion as the gas contracted. As, however, the mixture of air with the gas is not easy to accomplish, Dupuy de Lôme, following the example of General Meusnier, introduced into his balloon a smaller one filled with air for filling the place left by the contracted gas. A double purpose was hereby accomplished: in the first place, the constant filling of the

balloon was secured, so that it could fly through the air as a stable body; and, in the second place, the possibility of the movement of the gas from one end to the other was decidedly checked, which contributed very effectively to its stability.

The second means consists in the manner of hanging the car to the balloon * so that they were inflexibly bound together.

This is illustrated in the accompanying Figs. 1 and 2, where the balloon is indicated by the line AB , and the car by the line PQ . By suspending the car from

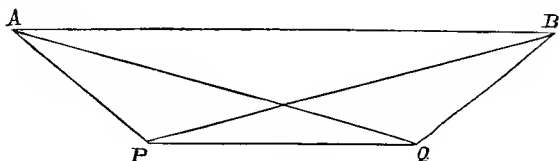

FIG. 1.

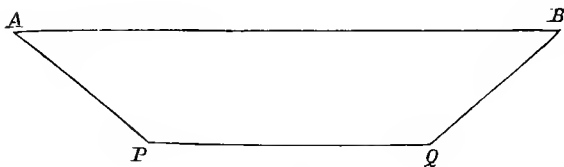

FIG. 2.

the points A and B with the cords or hangers AP , BP , AQ , and BQ , the displacement of the points P and Q is

* This method of hanging was not, indeed, original with Dupuy de Lôme. It was already known in America and in France.

held within certain limits, and sufficient stability of the whole is secured by the simple use of common ropes.

The rigidity thus secured must very materially steady the air ship lengthwise, so that the tendency to take an inclined position is much better counteracted by the arrangement shown in Fig. 1 than by that shown in Fig. 2.

It appears from the foregoing observations that correct ideas have been formed as to ballooning in calm weather, and that, leaving out of the consideration the question of stability of position in relation to the elevation attained, we must, in order to bring a balloon under control—

1. Give it an elongated form comparable to that of ordinary boats.

2. Insure the constancy of its shape by means of a small balloon placed inside of the large one, which will replace the contracted or escaped gas with atmospheric air.

3. Increase the longitudinal stability resulting from the use of this small balloon by attaching the car, by means of a rigid support, with triangular meshes.

4. Introduce a means of propulsion of suitable dimensions, combined with a motor, which shall have the maximum of power with a minimum of weight.

5. Establish at the rear end, as in ordinary vessels, a rudder by which the direction of the movement can be controlled.

With these means the question of aërial navigation

in its simplest form, and in calm weather, may be regarded as already solved. Thus far its general principles do not differ from those of ordinary water navigation.

That the problem is still incompletely solved, that it requires the creation of new and as yet unknown appliances, must not be ascribed to the peculiar properties of the atmosphere, but to another well-defined cause—namely, the wind, which we can neither avoid nor modify, and which, even in sailing a ship, we are obliged to contend with and counteract. By wind we must understand the moving of a stratum of air with relation to the earth, or, for the aëronaut, a movement of the earth with relation to the stratum in which he finds himself, because the balloon must be considered as belonging to this.

It is worthy of remark that wind considered as a motive power does not exist for the aëronaut, that it cannot be felt or observed by one who is immersed in the moving air, and that it cannot in the least disturb the equilibrium of the balloon.* It has for the aëronaut only the practical and important result that the earth moves under his feet with the velocity of the wind, and

* The velocity of the movement of the surface of the earth due to its daily revolution about its axis is equally little felt, because no power can be derived from it, and the free movement of the living beings and objects upon it cannot be disturbed thereby. The same phenomenon is to be observed in the case of carriages, steamboats, and trains.

in its passage mountains, towns, cities, and villages, and even the place which he desires to reach, are carried with it. The navigation of the air in calm weather has, as it were, an attainable fixed object; practical aërial navigation has, on the contrary, the movable aim of the flight of birds.

CHAPTER V.

THE EXTRANEIOUS OBSTACLE, OR THE WIND—ITS RÔLE IN AËRIAL NAVIGATION.

THE part that the wind plays in aërial navigation has added greatly to the difficulty of solving the problem. It seems to me also not thus far to be generally well understood and it becomes desirable that it should be more closely studied.

What we understand as wind manifests itself on the earth by the exertion of force which we call wind power, violence, etc. In this view there is, indeed, for the aëronaut, no such thing as wind. It exists for him only as a source of motion which, at a given moment and within the limits of the horizontal stratum in which he is floated, is to be regarded as straight and uniform.

If the balloon is, however, bound to the earth by one or more ropes, or anchored, then he feels, like everything else that is bound to the earth, the amount and force of the wind. For this reason an ascent in an anchored balloon is sometimes dangerous and always unpleasant.

If, however, the bonds are broken which attach it to

the earth and the balloon is allowed to rise in the air, its natural element, then the most severe shocks are quieted in a few moments and are followed by complete calm. The balloon, carried along by the storm, seems to be immersed in a layer of still air, or in the atmospheric ocean. The smoke of a cigar would, if smoking were permitted, rise vertically, while the trees, hundreds and perhaps thousands of metres below, are bending under the force of the wind, and the ships on the sea are braving the wild elements in great danger. The correctness of this illustration will be readily accepted, and it is, as it were, a daily incident of ballooning. It is, therefore, the basis of the following observations:

The wind—if the repetition may be excused—does not exist for the aëronaut, because he is enveloped in a layer of air and is cut loose from the ground. All that occurs, so far as the balloon is concerned, whether it can be propelled or not, is the same that would occur if the air were still. If the balloon can be propelled, it can move in any direction in this atmosphere, which to it is always calm, as if there were no wind. When moving forward, a breeze of greater or less force from front to rear will be felt; this, however, has no connection with the wind observed on the ground, but is a direct effect of the movement of the propelled balloon through the air. If the movement ceases, a complete calm soon follows.

The balloon, which belongs to the layer of air

through which it is moving, has nothing to fear from it, whether it is capable of propulsion or direction or not. The wind makes no difference either as to the sort of force which is in operation during the movement or as to the speed with reference to the surrounding air ocean in which it lies. All that takes place in the air ship takes place as if the air were motionless, and the earth moves under it with a velocity corresponding to that of the wind.

This idea being accepted, we can follow the effect of the movement of the ground, which Commandant Renard has clearly set forth by an illustration, in which it is assumed that there are assembled an air ship and twelve small air boats, which are floating over Paris; that they are for the moment without motion, and that, furthermore, the wind is blowing from the west—or, which amounts to the same thing, the air is motionless, and France with Paris is moving to the west—with a speed of about seven metres per second [fifteen miles per hour].

On an order from the ship the small boats leave the point of assembly. They move out in twelve different directions, the ship alone remaining in place. Assuming the speed of these boats through the air to be about three metres per second [six and a half miles per hour], they will then at the end of an hour be at the circumference of a circle which has a radius of six and a half miles, with the ship at the centre.

The earth has, however, moved to the west during

this manœuvre at the rate of fifteen miles per hour. Paris, which an hour before lay directly under the stationary ship, has now disappeared and lies fifteen miles away from it. On the other hand, the region fifteen miles from Paris, with the Marne and the small town of Châlons, stretches out under the plane of the circle of twelve boats, and the circumference of this region will be described by a circle of six and a half miles radius, of which Châlons is the centre. The effect of the west wind has thus been limited to the moving of the air fleet fifteen miles to the eastward without in any way changing the relative positions of the vessels. All have moved together in the same direction. Their respective movements with reference to the ground have been as follows :

The geometric circumference of the positions reached by the boats, propelled with the same velocity, forms at a given moment a circle of which the radius corresponds with the distance covered by their own speed through the air and of which the centre has been moved to a distance corresponding to the velocity of the wind.

This supposition is illustrated in the following four diagrams, wherein P is the point of departure of the twelve boats.

P¹ is the point reached by the ship, being at the same time the centre of the circle in which the twelve boats are placed after an hour's travel.

B E is the position of one of the boats at any

period of its travel. Its axis is parallel to the line $P M$.

M is the point reached by the boat $B E$ at the end of an hour.

$P P'$ is the distance representing the velocity, V , of the wind in one hour.

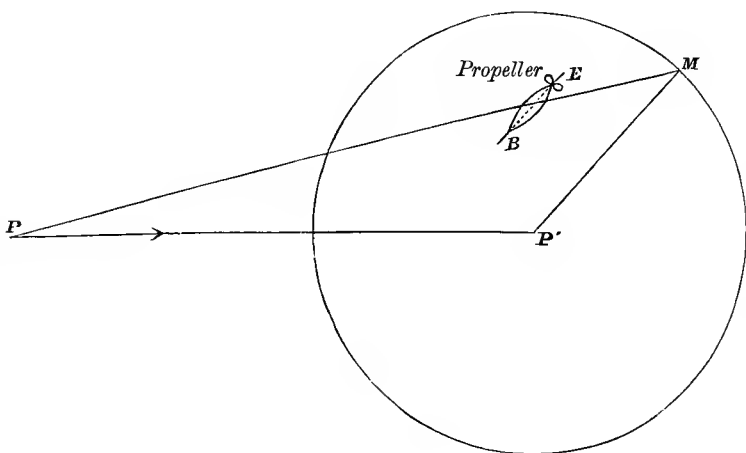

FIG. 3.

$P' M$ is the distance travelled by the boat $B E$ in one hour, v .

$P M$ is the distance representing the actual travel of the boat in one hour as seen from the ground.

The sketch shows the propeller as placed at the forward end of the boat.

The actual speed of the boat is therefore dependent on the motive power, the form of the vessel, and its size

and weight. It agrees, approximately, with the rate of propulsion of the balloon or air ship.

The application of these theoretical observations shows three cases in which the speed of the air boat, as measured from the ground, may be less, or equal to, or greater than that of the wind.

If it is less than that of the wind, as is assumed in Fig. 3, then the small circle in Fig. 4 shows the geo-

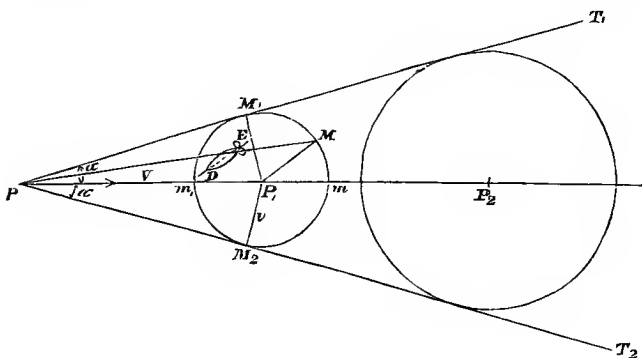

FIG. 4.

metric circumference reached by the boats after one hour, and the large one that reached after two hours, while PP^1 represents the velocity, V , and PP^2 that of $2V$.

Because V is greater than v , P is outside of the circle. If the two lines PT^1 and PT^2 are drawn tangent to the large and small circles, then it is clear that the boats originally starting from P cannot at the end of one hour have passed beyond the small circle nor beyond

the angle $T^1 P T^2$. After two hours, for the same reason, the whole series has moved to the circle whose centre is P^2 , the velocity of the wind for the two hours being represented by $2V$, and that of the boats by $2v$. Neither can the boats after two hours have gone outside of the angle $T^1 P T^2$. The whole atmospheric space may therefore be divided into two parts, one of which, included within the angle $T^1 P T^2$, can be reached by the boats, and the remainder of the space, outside of it, cannot be reached by them. The angle $T^1 P T^2$ will, for this reason, be called the "attainable angle."

For the point M , reached after one hour, $P^1 M$ is the direction in the air, and PM the direction over the surface of the earth, representing also the whole distance travelled by the boat in one hour. The maximum value of this distance is Pm or $V+v$, and the minimum PM^1 or $V-v$. In the first case the line of travel of the boat and that of the wind coincide. In the second case these lines are directly opposed to each other.

The maximum deviation occurs at the tangent lines PM^1 and PM^2 , where the direction of the movement is perpendicular to the actual line of travel.

The angle $P^1 P M$ or $P^1 P M^2$ will be called the "angle of the maximum deviation," and comprises one half of the attainable angle. It is expressed by the formula

$\text{Sin. } a = \frac{v}{V}$. If the inherent velocity of the boats is the

same as the velocity of the wind, then, according to Fig. 5, both tangents PT^1 and PT^2 are in the same

line, and the angle of maximum deviation is a right angle. The attainable angle then becomes equal to two right angles, so that one half of the horizon is accessible to the boats. Now, if P^1M is the direction of the boat or of its bow in the air, then PM is the actual line travelled over. The angle of deviation MPP^1 is equal to one half of the angle MPX formed by the

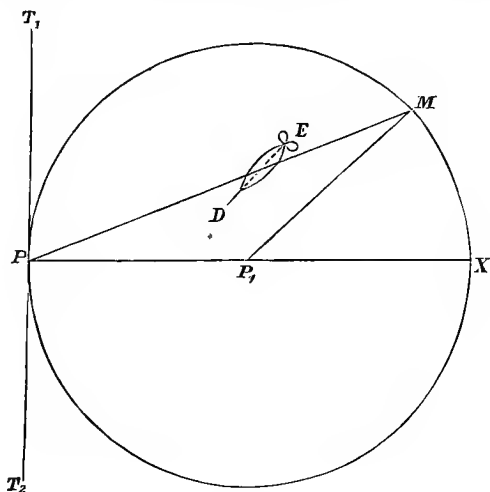

FIG. 5.

direction of the wind and that of the boat; the maximum velocity is twice that of the wind or of the inherent velocity, and the minimum velocity is zero.

Finally, if the inherent velocity v is greater than that of the wind V , then, according to Fig. 6, the point of departure, P , will fall within the geometric circum-

ference of the attainable positions, and the balloon can, therefore, command the whole horizon.

In this figure PM and PM^1 show the actual travel of the boats, and in the first case PM and in the second PM^1 show the direction of their movement through the air. The maximum velocity PM is again $V-v$, and the minimum velocity $PM^1 = v - V$, the inherent velocity and that of the wind being in opposition.

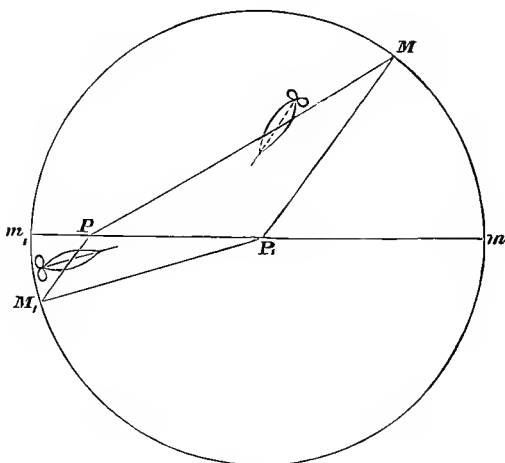

FIG. 6.

This geometrical analysis sets aside many incorrect observations, and demonstrates the falsity of the opinion that the inherent velocity of the boat need not be greater than that of the wind in order, when going against it, to reach a desired point by tacking like an ordinary sailing

ship. This, indeed, is impossible, while, whatever the direction of the boat or its bow may be, it can never get beyond the attainable angle, and it is further to be considered that in changing the direction it must fall farther to the rear. Consequently, to make the progress of the air ship possible, the condition is indispensable that its inherent velocity should be greater than that of the ordinary prevailing winds in those countries where aërial navigation is to be attempted.

This condition is clearly of only relative importance.

The boat that conforms to the theoretical requirements in calm weather, according to Chapter IV, can be controlled on certain days, and on certain days not, and in proportion to its increase of speed is the ability to control it extended.

In order to make this last condition practically useful, we must study the periods during which the wind blows with different velocities. To this end the velocity of the wind has been regularly observed at Châlons by means of a self-registering anemometer placed at the top of a mast ninety feet high on the plain of Châtillon. The results of these observations are given in the following table :

VELOCITY OF THE WIND AT CHALAIS.		Number of days in 1,000 when the velocity of the wind at Chalais may be expected to be less than that given in the first column.	Remarks.
In metres per second.	In kilometres per hour.		
2·50	9	109	According to the third column, we may expect that the wind will blow less than 40 metres per second, or 144 kilometres per hour, on every day of the 1,000. Nevertheless, greater velocities have been observed in exceptional cases. During the 11,049 hours of observation there was once 162, twice 153, and nine times 144 kilometres, during hurricanes from the southwest, which uprooted trees and destroyed roofs.
5·00	18	323	
7·50	27	543	
10·00	36	708	
12·50	45	815	
15·00	54	886	
17·50	63	937	
20·00	72	963	
22·50	81	978	
25·00	90	986	
27·50	99	991	
30·00	108	995	
32·50	117	996	
35·00	126	998	
37·50	135	999	
40·00	144	1,000	
42·50	153	1,000	
45·00	162	1,000	

According to this table, when the inherent speed is 12·50 metres per second [twenty-eight miles per hour] the boat can move in any direction eight hundred and fifteen out of one thousand days, and during seven hundred and eight of these days it can make two metres and a half per second [more than five miles and a half per hour] against a wind with a velocity of ten metres per second [twenty-two miles and a half per hour].

This velocity would make the free navigation of the air practicable under most circumstances. We may therefore conclude that the aëronautic problem will be

practically completely solved when we shall have arrived at the production of a balloon that can be propelled with a velocity of twenty-eight miles per hour, and when this velocity can be maintained, for example, for a whole day, or for ten or twelve hours.

By renewals of the motive force at different relays, which it is possible to maintain, like the taking of water for locomotives, an even shorter period may suffice. We need therefore grope in the dark no longer, and this is a great point already gained. We may also count on a constant improvement in the propelling appliances, and on the possibility of lessening the resistance of the air as the flying machine runs through it, which will guarantee the final solution of the question. Many experimenters will unconsciously work together, and the art of navigating the air will finally be due not to a single person but to many. Attention must, however, first of all be given to more powerful motors with the least possible weight. Even then everything will not have been achieved, and serious difficulties may yet remain; but we shall have secured the great condition that dominates all others in aërial navigation.

CHAPTER VI.

PRACTICAL RESULTS ALREADY REACHED IN MACHINERY FOR PROPELLING BALLOONS.

BEFORE discussing the practical results thus far reached with the machinery for propelling balloons, it will perhaps not be amiss to observe that the noteworthy experiments and observations undertaken on the part of the Government at the military arsenal at Chalais relate exclusively to balloons. These have thus far applied to modified and elongated forms which alone are used by the French military department. The experiments instituted were undertaken under the direction of Commandant Renard, from whose description of them this account is taken.*

Meanwhile, it will appear further that the study of aërial navigation is also prosecuted in another direction, and can even be regarded in some degree to have entered a wider field of observation. This does not deprive the investigations at Chalais of great scientific value and of much importance to the study of aëronautics.

* *Revue de l'Aéronautique Theorique et Pratique. Première année, 1888.*

The aërostatic installation at Chalais (Meudon), where the investigation of aërial navigation was carried on with reference to its military use, had since 1878 been applied especially to the propelling of balloons and to the applicability of electric motors. The condition was assumed that the balloon must return to its point of departure, which in the earlier experiments was not fully accomplished. The inherent velocity of the balloon had not been sufficient for this purpose, and must, for that end, be increased. This involved a serious difficulty, inasmuch as the motive power per unit of time is in general as the cube of the velocity, and that this rule obtains in aërial navigation. It was also further considered that for the success of the experiment the former speed must be doubled, and that, under nearly similar conditions, the weight of the motive appliances must be reduced to one eighth.

Account must further be taken of the former great obstacle of the resistance of the air caused by the spherical form of the balloon. It was therefore resolved to make this oblong, in order that its velocity might be increased to the utmost. It was thus necessary to satisfy two conditions, which it was apparently impossible to reconcile—that is, the weight of the machinery must be very much reduced in combination with greatly elongated balloons, and this without imperilling their stability. Finally, other details, especially the position and satisfactory working of the rud-

der, required improvements, to which little attention had yet been paid.

The motive power employed in these experiments consisted of an electro-dynamic apparatus with a galvanic column admirably suited to it. The machinery was of the usual Gramme type, and the greatest possible power was thus secured with the least weight. In 1885 this apparatus was replaced by a stronger combination supplied by Gramme.

Both appliances together weighed about two hundred and twenty pounds, and as the force developed at the shaft was estimated at eight horse power, the weight of the machinery was twenty-eight pounds per horse power.

This result was certainly satisfactory. But the great difficulty lay not so much in the weight of the machinery as in that of the galvanic column required to produce a force of eight horse power during a certain time—fixed at two hours—while the total weight must not exceed eight hundred and eighty pounds; corresponding, therefore, with a weight per horse power, independently of the working time, of..... 111 lbs., and per horse power, per hour, of..... 55 lbs.

Previously, however, in 1883, a trial had been made with an experimental model of a propelled balloon of only sixty cubic metres' capacity and provided with a motor of one half horse power, weighing twenty-two pounds, and with a galvanic column capable of producing one half horse power for one hour and a quar-

ter. The speed obtained with this model was very satisfactory, reaching 4·5 metres per second.

Accordingly, the galvanic column for eight horse power was made by Commandant Renard and the electro-magnetic motor by Captain Krebs. The advance thereby made, as compared with accumulators, with Tissandier's galvanic column, and with human power, is shown in the following table :

	Renard's galvanic column.	Accumulators (practical average of the best appliances).	Tissandier's galvanic column.	Man power (eight men employed by Dupuy de Lôme).
Total weight*.....	400	..	225	600
Maximum energy in horse power of 75 kilogrammes on the shaft.....	9	..	1·33	0·65
Time of working.....	1 h. 45 m.	4 h.	2 h. 30 m.	3 h.
Weight per horse power, independently of time:				
Actual weight.....	44·4	300	170	900
Weight, Renard's column being taken as the unit.	1·0	6·7	3·8	20·3
Weight per horse power per hour:				
Actual weight.....	25·0	75	68	300
Weight, Renard's column being taken as the unit.	1·0	3·0	2·7	12·0

If the motive power alone is considered without reference to its duration, then the weight of the galvanic column of Chalais is only one fourth of that of Tissandier, one seventh of that of accumulators, and one

* The weights given are in kilogrammes.

twentieth of that of human power, according to Dupuy de Lôme.

If, on the other hand, account is taken of the duration of the working, and if the weight is reduced to the unit of one horse power per hour, then the table shows that the galvanic column of Chalais is three times lighter than the accumulators and the galvanic column of Tissandier, and twelve times lighter than human power, as obtained by Dupuy de Lôme.

The improved application of electric power in the case of the balloon "La France" has thus marked a great advance, and I would recall in this connection (Chapter IV) the fact that Giffard, in 1855, in order to lessen the resistance of the air, risked an ascent in a balloon ten metres in diameter and seventy metres long. The proportion was one to seven, and the result was that the heavy pitching during the descent soon wrecked it.

The balloons of Dupuy de Lôme and Tissandier, whose stability left nothing to be desired, were not nearly so long as that of Giffard. The resistance to the air was, however, with reference to the weight required for the motive power naturally much greater.

For this reason the elongation adopted at Chalais in 1884 was sufficiently reduced. The balloon "La France" had a diameter of 8·4 metres and a length of 50·4 metres, so that the proportion was one to six. Nevertheless, various improvements were made and precautions taken which obviated the danger of pitching.

A comparison of the results obtained with the above-named balloons seems important with regard to the elongation of the form. These are set forth in the following table, wherein the value of the propelling force is also shown per unit of cross-section of the resisting surface, and where it is to be observed that the fastest balloon is that which, other things being equal, has the greatest power per unit of resisting surface :

	Giffard (1855).	Dupuy de Lôme (1872).	G. Tissandier (1883).	Chalais, balloon "La France" (1884).
Dimensions of the balloon:				
Diameter in metres	10·0	14·84	9·20	8·40
Length in metres	70·0	36·12	28·0	50·40
Relation of the diameters to the length	7·0	2·43	3·04	6·0
Total propelling force in horse power	3·0	0·65	1·33	9·0
Area of cross-section in square metres	78·5	172·8	66·5	55·4
Propelling force per 100 square metres cross-section:				
In horse power	3·82	0·38	2·0	16·25
Compared with that of the balloons of Dupuy de Lôme	10·0	1·0	5·3	42·7
Compared with that of the balloons of G. Tissandier	1·9	0·19	1·0	8·1

The power per unit of cross-section thus appears to have increased materially, for with Giffard's balloon it was ten times, with Tissandier's five times, and with that of Chalais forty-two times the power of Dupuy de Lôme's

balloon. The Chalais balloon has also eight times the power of Tissandier's.

From the foregoing general rule concerning the relation between power and speed, and from the figures given above, it is further to be considered that the speed of the Chalais balloon must amount to twice that of Tissandier—a relation which was very closely established by experiment.

In conclusion, it appears, from a comparison of "La France" with Tissandier's balloon, that the weight of the motive power employed is in the proportion of one to four; that the elongation of the former was twice that of the latter; and that the stability, because of the precautions taken, was not endangered; and, finally, that the power per unit of resisting surface, or cross-section, amounted in the former to eight times that of the latter.

Furthermore, the Chalais balloon differed in having various improvements relating to the general form of the envelope, the arrangement of the car and of the rudder, the placing of the rudder and of the propellers, etc. These details all contribute in greater or less degree to the improvement of the conditions contributing to speed and to steadiness of direction, which had in its predecessors left so much to be desired. In a word, a balloon had been made constituting a rigid mass in the air, and within the limits of its movement obeying immediately the least indication of its rudder.

CHAPTER VII.

EXPERIMENTS WITH THE BALLOON "LA FRANCE" IN THE YEARS 1884 AND 1885.

THE experiments with this balloon in 1884 and 1885 produced results which are of great use in the study of aërial navigation. The first trial was made in calm weather on August 9, 1884. The two aëronauts were Commandant Renard and Captain Krebs. They thought it advisable to limit the trial to a few kilometres, and not to make use of the full indicated power, which, however, did not prevent their expectations being exceeded by their success. As soon as they had reached the wooded heights that enclosed the valley of Châlons the propeller was put in motion. The balloon was immediately started forward and yielded readily to the indications of the rudder. Renard testified that they were in complete control of the direction, and that they could turn the balloon towards any point as easily as they could a steamer in a smooth sea.

After having reached Villa Comblay, the bow was headed for the meadow from which the balloon had ascended, it having been decided to alight there in

spite of the surrounding obstacles.* They reached this field at an elevation of three hundred metres. The speed of the screw was then slowly reduced, and the safety-valve was opened, so that a slow descent followed. With the help of the motor and with the rudder they kept the balloon almost immediately over the landing place and laid the car gently on to the grass.

In this trip the important conditions were fulfilled that the balloon had been controlled with practical exactness, that it had moved freely in the air, and that it was brought back exactly to the point of departure.

Three more experiments were made in 1884. On September 12th the balloon went up in a fresh breeze blowing from the west with a velocity of about six metres per second (about thirteen miles per hour). It withstood the wind, and might probably have been brought back to Chalais if some mishap had not disabled the machinery.

The accident was of very little importance in itself, but it made an unfavorable impression and had a bad effect. It probably contributed to this that many were entirely opposed to experimenting exclusively with balloons. This was, however, a wrong opinion, and was due to a misconception of the scientific purpose in view.

* The field is about seventy-five metres wide by one hundred and fifty metres long, and is surrounded by high trees and buildings, while it is bordered at one side by a pond of some seven acres.

Afterwards, on the 8th of November, another ascent was made, and the precaution was taken to carry along the whole galvanic column. The weather was beautiful, and the balloon was directed towards Boulogne.

After the Seine had been crossed near the bridge at Billancourt, it was, as on the first trial, made to return to Chalais without the least difficulty. During this trip it attained a speed of six metres per second (thirteen miles per hour). In the afternoon of the same day it was sent up again. In consequence of the rising of a fog they did not dare to venture far from Chalais. The balloon remained soaring within the circumference of the park, and the landing was made in the field from which it started. These ascents were always made by the same aëronauts—Messrs. Renard and Krebs—whose attention was given exclusively to the propelling of the balloon, so that there was no question of a correct record of speed. They confined themselves to the counting of the revolutions of the screw, and to the measuring of the force and tension of the currents resulting from the source of power. From these figures, however, the actual speed has since been worked out in close comparison with those of 1885.

These first experiments showed the need of a third man in the balloon, in order that the necessary measures for steering could be carried out with greater security. This required that the weight of the balloon should be reduced, and consequently that its different

parts should be modified. The car was furnished with a light and sufficiently strong motive apparatus by Gramme, which had for many weeks been most severely tested.

On the 25th of August, 1885, the trials were resumed. In the first flight, the return to Chalais was prevented by the velocity of the wind. Save for this apparent misfortune, the day's experiment was very useful, as it indicated the satisfactory working of the machinery.

On the 22d of September, in a northwest wind blowing four metres per second (nine miles per hour), the balloon went up from the usual spot, with Commandant Renard and Mr. Duté Poitevin, the civil aëronaut of the arsenal at Chalais. It was headed towards Paris and started straight against the wind. The full force of the machinery was employed, and, notwithstanding the head wind, the balloon soon passed the Seine, and shortly after that reached Boulogne and Point-du-Jour. After passing the fortifications, the course was laid towards Chalais, and, now favoured by the wind, the balloon arrived there promptly. Eleven minutes sufficed for the return trip, while the outward trip had occupied forty-seven minutes. The trial was repeated the next day, and though the wind now carried the balloon towards Paris, the expedition was nevertheless completed under the same conditions as the day before

After that, the experiments were discontinued, as it

was desired to make various improvements and to increase the power and speed of the machinery.

Concluding now the consideration of air balloons, we will next turn our attention to an examination based on Nature and on the movement of birds.

CHAPTER VIII.

THE FLIGHT OF BIRDS.

THE movements of a bird in flying are generally too complicated and too rapid to be observed in the usual manner and with the naked eye. Furthermore, the laws which govern the resistance of the air were until now so imperfectly understood,* that it was not possible to take full account of the two important facts: that the bird, supported only by the exertion of its own mechanical force, is able to maintain its position in the air; and that flight is possible only because this furnishes a fulcrum for the wings. Now, however, as the study of mechanical flight has been taken up in such a

* The study of the laws governing the resistance of the air has always been carried on under the simplest conditions. We have confined ourselves to the resistance that rigid surfaces of certain forms offer when they remain in the same relation to the line of motion. These observations are, however, not applicable to bird flight, because the resisting surfaces of the bird are very complex. Their form and size, under the influence of the resisting medium, and according to the greater or less spread of the wings, are constantly being modified; and, finally, these surfaces are in constant motion and in constantly changing relation to the line of advance.

systematic manner, an understanding of the flight of birds has become more and more necessary; and we borrow the following observations from the valuable work, *Le Vol des Oiseaux*, of Prof. E. J. Marey, of Paris.*

The former opinion that man can fly for the simple reason that birds fly now finds no acceptance. It had, indeed, no reasonable foundation, because the most complete means of conveyance attained up to this time are not borrowed from Nature, but differ widely from it. A correct knowledge of the laws of Nature should be all the more valued, however, because through the development of science in many directions it will become more and more possible to establish the physiological and mechanical conditions of bird flight. We can already make observations as to all the movements made in the raising and depressing of the wings, and can count them, and can measure the strength of the birds. We can also determine their course with much exactness, and, from the manner of their flight, can even determine their successive retarded and accelerated movements.

In order to get a correct idea of the mechanism of bird flight, it will, however, be necessary also to pay attention to the anatomical similarity of the organs of motion observed in birds and in animals moving on the

* *Le Vol des Oiseaux*, by E. J. Marey, Member of the Institute and of the Academy of Médecine; Professor at the College of France, Paris. G. Masson, 1890.

earth's surface or in the water. Even anatomy cannot be disregarded, for flying is not made impossible by clipping the wings, nor by depriving them of some of the flight feathers; neither is the tail absolutely necessary as a rudder, for in its absence the bird finds other means which serve the purpose. Therefore, due consideration must be given to anatomy.

Observations as to the movements of birds in flying have been made possible by the graphical methods of chronometric observation and photography, by optical analysis of the movements, and by instantaneous photography. By these means we have in a measure analyzed the movements of birds; yet, in order to obtain practical results therefrom, we must be able to imitate their flight, and attempts have been made in this direction. We are already able to reproduce some of their movements, such as the up and down strokes of the wings, and the floating in the air of a winged machine, in which the weight and the surface provided for its support are brought into accord, while we have been able to determine the various directions taken by different forms of such machines in their flight.

These imitations have already furnished encouraging results, so that the artificial appliances imitating the action of bird flight have been observed by optical instruments or by chronometric photography to detect imperfections which were invisible to the eye.

It is to be remembered in this connection that when-

ever a mechanical problem is thoroughly studied, the mathematical formulæ for its application can be established, as has been done for nearly all machines. We have, however, not yet gone so far as this with reference to flying, and we have until now tried in vain to form a scientific theory concerning it. For this reason the calculations thus far made are little to be relied upon, and considerable time will probably elapse before most of the questions relating to it will be cleared up by experiment and observation. Furthermore, while there is no doubt that we shall eventually understand all the movements of birds, there will still be needed for their application a complete knowledge of the resistance that the wings encounter in the air. This investigation is hardly begun. We are, therefore, still far from attaining the end in view, but we do know in what direction to turn our efforts, and we are in a position to take due account of the requirements already determined or still to be learned.

The movements of all birds in flying are very different, and they depend on various circumstances. They are, for example, different in regular flying, in soaring, and in sailing in the air—the last two forms of flying being made with almost motionless, outstretched wings.

We shall endeavour to set forth these methods of flight after having made some observations on the phenomena connected with the flying of the common boy's kite, which has already been brought into the realm of

science by that renowned student of Nature, Franklin, who used it to prove the existence of electricity in the air.*

* For this purpose a thin copper wire was substituted for the string.

CHAPTER IX.

THE BOY'S KITE.

THE laws that come into play in the flying of a kite are involved in the flight of birds without the actual movement of the wings, such as the sailing and soaring above referred to. The kite is flown under two very different conditions, namely, in a wind of greater or less force, and in calm weather, or when the air seems to be in a state of rest.

In the first case it is sufficient that the string of the kite be held firmly or tied to a fixed point, because if ballasted by its tail it rises of its own motion, and continues to rise until it reaches an elevation where it stands still in the air, and remains there so long as the wind maintains the same velocity. In the second case, it will rise in like manner whenever it is moved forward by a person running and drawing the string with him. This movement has only the result of creating a wind under the kite, although it is not the air, but the kite, that moves. The result of both forms of motion is the same. (See Chapter V.)

Let it now be supposed that in both cases the kite is

maintained steadily at the same height, and that it has as little tendency to rise higher as to fall, so that the resultant of the air pressure resolves itself into a vertical and a horizontal force.

The vertical force is, in this analysis, applied to overcome gravitation, and must, therefore, in order to maintain the stability and equilibrium of the kite, be equivalent to its weight.

The horizontal force perceptibly indicated by the tension of the string will, however, be neutralized, for the immovable position of the kite shows that the equilibrium attained is not disturbed by any of the existing forces.

Still, until this condition of equilibrium is attained—that is, so long as the kite is rising—it is exposed to varying air pressures, and these are dependent on the angle at which its surface is presented to the wind. At the moment when the kite is first let up, we may assume that its face is nearly perpendicular to the current, and that the whole force of the wind acts horizontally against it. The kite then develops a maximum drawing power, and the string is under the strongest tension, so that the vertical force is barely sufficient for the lifting of the weight.

In rising, however, the angle of the kite with the direction of the wind becomes constantly smaller, and so the tension on the string grows less. We feel, as it were, less pulling by the kite, and the decrease continues

until the moment when it reaches its greatest height and stands still, or the moment when it arrives at its state of equilibrium.

The equilibrium is disturbed, however, whenever the wind rises or becomes stronger, or whenever the person holding the string moves forward. The kite will by this increase of wind tend to rise higher ; it will, on the other hand, tend to fall when the velocity of the wind decreases.

Furthermore, the force exerted on the kite may have different values with winds of the same force. This is dependent on the manner in which the string is attached to it, because this determines the angle at which the surface is presented to the wind.

The rising of the kite, then, depends on both the velocity and the direction of the wind and on the angle of the kite with this direction ; for it is by this that the development and effect of the horizontal and vertical forces which act to raise the kite, and which therefore present themselves under modified forms, are regulated.

Let it be supposed that the place of the kite is taken by a bird with outstretched wings moving with great velocity through a still air, or that it stands motionless in a strong wind, with a tendency to fall towards the earth ; then, in both cases, the wings are exposed to the action of the wind, and the composite air pressure on the bird's mass will act in the same manner as on the

kite. This can thus be divided into two forces, of which the vertical is equal to the gravity or the weight of the bird; and the other the horizontal, whether due to the velocity of movement or to the resistance offered to the wind by the body and wings, equals the pressure against these.

CHAPTER X.

THE ORDINARY FLYING OF BIRDS—"ROWING" FLIGHT.

THE rowing flight of birds takes its name* from the similar movement in the water of oars moved by rowers. The two movements have, however, the difference that that of the oars is horizontal, while that of the wings is vertical. The work of propelling a rowboat is developed during the forward stroke of the oars in the water, while little if any force is developed during the return stroke, because this movement is in the air.

The mechanical force required for "rowing" flight is developed during the downward stroke of the wings, not while they are being lifted. A part of the force is taken up and accumulated in the mass of the bird, as momentum, which during the passive phase, or while the wings are being lifted, serves to support the body of the bird against the air, like a kite.

The amount of force so developed is not a constant quantity. It tends towards a minimum, and this is

* Ordinary flying, with regular strokes of the wings, is called, in Dutch, *Roeiende* flight. The designation "rowing" is used in all cases as its English equivalent.

reached when the number and extent of the strokes are reduced to the utmost. This indeed is fully shown by various experiments (see Chapter VIII), by which several problems connected with animal motion may be solved.

When mechanical flight is under consideration the question, What force does the bird consume in flying? acquires the greatest interest. On this will indeed depend the power to be applied to the propelling of flying machines, whether the muscular strength of the man can be used, or whether special mechanical appliances must be provided.

To determine this, the sum of the energy expended—being the force multiplied by the distance travelled by its point of support—must be determined. This we express in the case of living or animal motive power, as in the case of ordinary motors, in kilogramme-metres.*

It is to be remembered here that it is very difficult to estimate with precision, in the case of the flight of a bird, the force and the distance through which the supporting point travels, because of the complication and rapidity of the movements. Observations and experiments concerning bird flight have, therefore, produced no satisfactory results from which to estimate the energy consumed in its rowing flight.† This point

* This unit indicates the power required to raise one kilogramme to the height of one metre (the unit in English is "foot-pounds").

† In this connection, the strange calculations of Navier may

must some day be reached by the help of chronometric photography, but these observations are of the most delicate character, and their application calls for much scientific knowledge. It is to be remembered also that they relate only to the condition of the moment, and that they are made while the force exerted by the bird is changing every instant, and this decreases as its speed increases. In rowing flight the force exerted reaches its maximum, though only for a few moments, at the instant when the bird starts up; as soon as a certain speed is reached the flight becomes easier, and the air gives greater support to the wings, while the length and number of strokes diminish. Consequently, the bird needs to exert considerably less force in full flight than in its rising or in the beginning of its flight.

be recalled, by which it is shown that thirteen swallows exert one horse power, or 75 kilogramme-metres, per second. The above uncomplimentary expression is justified because the data on which the computation was founded were not reliable. Without taking account of the nature of the movements of bird flight, or of the resistance of the air, Babinet thought it might be assumed that, considering that a bird would, in consequence of gravitation, fall 4.90 metres in the first second, in order to fly horizontally it must exert as much force as would be necessary to lift its own weight 4.90 metres. Concerning this, it is pertinent to say that if we take the unit of time not as one but as two seconds, the height of fall becomes 4.90 metres $\times 2^2$, or 19.60 metres, and that it must, therefore, lift its weight 19.60 metres in two seconds, or 9.8 metres per second, and so must exert twice the force. D'Esterno has, therefore, thought it necessary to consider only the height of fall during the time in which the bird, before flying, is subjected to the influence of accelerating gravitation. Now, this is a correct standard, but it can be established only by many experiments.

It has, in fact, been observed that in the case of the sea-gull the number of strokes per second in full flight is little more than three, while it is as much as five at the beginning of the flight.*

Let us now suppose that each stroke of the wings requires the same force, then the amount of work done at the beginning of the flight and in full flight will be in the proportion of five to three.

Furthermore, the extent of the strokes decreases with their number, and amounts in full flight to only about one third part of that made at the first moment of rising. It may thus be estimated that if, at the beginning of the flight, T represents the work done by the bird in one second, the work in full flight will amount to only $\frac{3}{5} \times \frac{1}{3} T = \frac{1}{5} T$, and so that the more

* It is established that the average number of wing-strokes per second is, for the

Stork.....	1 $\frac{3}{4}$ stroke.
Carolinian kite....	3 $\frac{1}{4}$ strokes.
American vulture.....	2 $\frac{4}{5}$ “
Great gull.....	3 $\frac{1}{2}$ “
Common gull.....	5 $\frac{1}{2}$ “
Pelican.....	1 $\frac{1}{6}$, or 70 to the minute.
Pigeon.....	10 strokes.

The wing-strokes are, moreover, governed by various conditions. In descending, they decrease, and sometimes cease entirely, when the flight is very rapid. They increase, on the other hand, in rising and when the bird holds itself in one position, when it desires to increase its speed, when it carries a heavy body with it, and, finally, when its wings are clipped.

This has already been observed by Mouillard in the case of pigeons whose flight feathers he had cut to make the wings shorter.

and more rapid the movement, the less and less effort will be required to maintain the bird's position in the air.

It is also to be observed in this connection that the movement of the wings meets with more supporting resistance in the air as the horizontal speed of the bird increases. This appears clearly in the flight of a gull over the surface of the sea. It makes at first long strokes of at least one hundred or one hundred and ten degrees scope, but as its speed increases the sweep of the stroke decreases, until the angle covered is only thirty to forty degrees. These birds sometimes fly for a considerable space close to the water without rising or falling. Their movements are then marked by great regularity.

Further, it appears that the elevation at which the bird flies is maintained when the sweep of the strokes lessens, and that those of less sweep suffice for its support then, just as the greater sweep did at the beginning of the flight. The difference shown between the beginning and the continuance of horizontal flight depends on this, that as an increased speed is attained a firmer support is given by the air.

This supposition is confirmed by the following experiment: The legs of a large gull were tied to a long string that could unwind readily. At first the bird flew off as though it were free, but as soon as further horizontal movement was prevented by a tension on the string it fell heavily down, and was, in spite of the

movement of the wings, unable to support itself in the air. This phenomenon is, in certain respects, the opposite to that which we notice when the bird begins to fly, because there is then an increasing velocity.

The fact last stated seems to be explained by the resistance of the air: that is, when a rapid movement is given to the air by an external force, as by the downward stroke of the wings, its resistance becomes less. Thus, when the bird moves its wings up and down without changing its position, they act on a column of air which at first offers resistance, but afterwards, by reason of its quickened motion, escapes from under the wings. On the other hand, if the bird is moving horizontally, then the wings bear successively on a series of columns of air, and they find in each of these the original resistance due to its inertia. This theory has been established by a series of experiments.

While the vertical resistance of the air is thus increased by a swift movement of the bird, the same is not true with reference to horizontal resistance. This decreases, however, during a certain time, under the influence of the velocity, which is shown by the lifting wing, which presents itself in the air at an angle of increasing acuteness, but when that angle has decreased to a minimum the resistance of the air to the movement of the bird no longer decreases it increases, on the contrary, as the squares of the velocities. Thus the velocity of flight has its limits.

We may, indeed, in the case of all birds, observe

that the flight at its beginning requires the exertion of much force. Pigeons, which can for such a considerable time support themselves easily, almost playfully, high in the thin air, and which can fly to such great distances, will after successive ascents with a flight of hardly twenty metres' length, refuse to fly at all, gasping with open beak. If they are then compelled to fly again, they take only a downward sweep, and go almost immediately to rest.

CHAPTER XI.

HOVERING FLIGHT.

HOVERING flight is to be regarded as the gliding of the bird over a stratum of air. It occurs only in a calm, and requires further, as a condition for this movement, that the bird shall previously acquire a rapid motion. This speed, however it may first have been acquired, will be slowly expended and used up during the hovering. It serves to support the bird and to overcome gravitation. Thus, in like manner, in the falling sweep gravitation tends to increase the speed, so much so that it may be fully maintained during the whole time of such descending flight. Hovering flight has recently been compared with the flying of a kite, and has been observed under the following circumstances :

1. The bird which has for some time flown with strokes of the wings discontinues the strokes for a time, and assumes the horizontal movement; or—

2. It lets itself fall from a high position and spreads its wings as it gains sufficient speed for hovering. The force developed in falling carries the bird along, after the manner of a kite of which the string is drawn forward. Such hovering, which interrupts the regular rhythm of

rowing flight, may often be noticed in the case of herons, storks, hawks, gulls, vultures, and in general with all birds with outstretched wings.

In this flight the bird cannot raise itself in the air without greater or less loss of the velocity which has been attained by the movement of the wings. The loss of elevation, theoretically assumed, is not always perceptible to the eye, neither is it always inevitable. It appears, in fact, by observation that the bird cannot only hover without falling, but in case of need it can with the loss of a good part of its velocity rise higher. In this connection it is interesting to watch the manner of flight of falcons. They begin when set free by flying against the wind at an angle with the horizon of from fifteen to twenty degrees, which apparently calls for much effort; for if the distance to be gone over is too great, the bird interrupts its rising flight from time to time and is carried back horizontally by the wind so far as to come each time over the point from which it started. It thus rises by a zigzag course without a loss of elevation in the return movement, and continues thus until it has reached the position required for falling upon its prey. Its fall from the high air is made with great velocity, the wings being pressed closely against the body, describing a curve which brings it directly upon the quarry. Should this, however, escape it, then a slight change in the position of the wings and of the body suffices to turn its course upward again and to carry it back to the height from which it first swooped

down. This manœuvre is sometimes made repeatedly, until the falcon reaches its quarry and brings it tumbling to the earth, where it is despatched.

The pursued bird, on the other hand, tries to escape by turning suddenly upward or to one side, but the direction of the swoop of the falcon is nearly always so precise that it rarely misses its aim.

The velocity of its descent is greater in proportion as its direction is steeper. The falcon sometimes comes down perpendicularly and, as it were, in the twinkling of an eye. The duration of this fall is estimated to be in this case only the one-hundredth part of that of the ascent. The rising from such a descent is, however, very rapid.

The hovering flight which a bird can assume when it descends from an elevation may also sometimes be used to rise to a certain height.

When a pigeon seated at the edge of a roof flies to the ground, it does this with a hovering movement, but in various ways, according to the point to be reached, whether this is vertically under the point of departure or at some distance from it horizontally. In the first case the pigeon may simply go straight down by spreading the wings and the tail in such a way as to have three points of support in the air. The velocity attained is nevertheless considerable, and before it reaches the ground it has to check its motion with several strong strokes of the wings. In order to reach the ground with less velocity, the pigeon sometimes describes circles

which are wider according as a slower descent is required. On the other hand, if the point to be reached is horizontally far enough away from the starting point to be reached by a sloping sweep, the bird simply lets itself go, gliding downward through the air with outstretched wings, and if the movement given by gravitation is insufficient, it is aided by a few strokes of the wings. This brings up an important question, What is the greatest horizontal distance that a bird can cover when it lets itself glide through the air from a given height? This is dependent in downward hovering on the relation of the height of the drop to the horizontal distance traversed. This relation has been variously estimated. According to D'Esterno, it must be taken as one to eight, equal to an angle of seven degrees formed between the line traversed and the horizon. According to Moulliard, the angle amounts to ten degrees. Tatin found by his experiments with hovering appliances that the proportion of one metre vertical to eight metres horizontal gave the slightest slope that could be depended upon.

Finally, Bretonnière, on the basis of his observations on the flight of storks, concludes that the least slope at which hovering can take place is at an angle with the horizon of ten degrees.* This rough estimate or calcu-

* Bretonnière's observations related to the descent of storks from the high-lying rocks on which stands the city of Constantine. According to these, the birds swept through the air to a distance in a direct line of more than one kilometre. The velocity of the

lation is based on very close measurements of the relative heights and distances between the places of departure and of arrival of the birds. In estimating the angle between the line of flight and the horizon, it is to be considered that the course is never a right line for its whole length, but is at the beginning a curved line, which appears to be parabolic, and at the start nearly vertical, slowly attaining the minimum slope, which is continued to the end. An imaginary line was drawn through the points of departure and arrival, and this was taken as the average inclination of the course.

Here the question arises whether or not the bird always takes such account of the effect of gravitation as to reduce the resistance of the air to its horizontal progress to a minimum, so as to reach the end of its course just when its momentum is expended. This condition being complied with, hovering at an angle of ten degrees may be observed to take the best advantage of gravitation for traversing a given horizontal distance. Knowledge as to this has not yet been acquired. The computations of Bretonnière relate only to the rectilinear part of the course of the stork, so that he includes the parabolic portion or the part in which the bird first falls by gravity with a vertical movement and with accelerating speed in order after that to go with a slight slope in which the

bird's movement and the inclination of its course appear by the numerous observations not to vary in any marked degree, and with a velocity of flight of twenty metres per second the inclination of the line was equal to an angle with the horizon of ten degrees.

rate of fall is diminished. He considered only that portion of the course in which the bird moves at a fixed speed and at a fixed inclination, and while the movement is regular in both respects. In illustration of these remarks, in the following sketch the direction of the wings of a hovering bird are indicated by the heavy lines at A and at B, the course of the bird's movement, at first parabolic and afterwards rectilinear, by the dotted line A B C, and the horizon by the dotted line D E.

M. Bretonnière now computed the two angles α and β ; that formed by the direction of the wings and the horizon $\alpha = 5^\circ$, and that formed by the line of travel

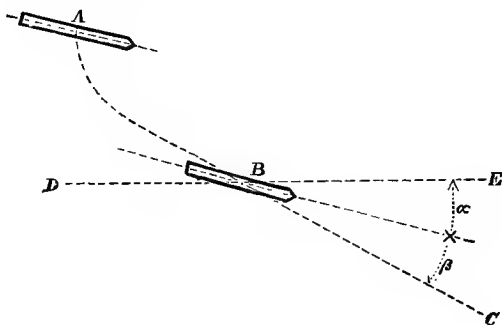

FIG. 7.

$\beta = 5^\circ 23' 11''$. Wherefore $\alpha + \beta$, or the angle of the line of travel with the horizon, amounts to about ten degrees.

It is here to be remembered that when the combined force, including the amount of air resistance caused by

the sloping plane of the wings, is separated into a vertical and a horizontal force, then, the more the angle of the wing plane with the horizon increases—that is, that as the descent of the bird becomes steeper—the horizontal force in fact increases; but, on the other hand, the reacting vertical force which supports the bird in the air decreases, so that it is compelled to fly faster. If the bird were not able to comply with this condition, it would not be sufficiently supported, and might lose its balance.

If, on the other hand, we suppose the bird to be soaring upward, then the sum of air resistance will increase with the angle of the wing plane with the horizon, and, consequently, the reacting horizontal force of this air pressure must have a more and more retarding influence on the flight. The momentum of the bird, already established, whatever its origin, whether by falling or by the use of the wings, would appear to be insufficient, and to require increased air resistance through greater velocity.

In order to reduce these considerations to figures, Marey supposes a hovering plane of a certain size to be placed at an angle with the horizon of ten degrees; the total vertical air pressure is taken as one hundred and thirty-two grammes, and the horizontal pressure as fifteen grammes. Then, if the weight to be supported is not more than one hundred and thirty-two grammes, the angle of ten degrees is sufficient. If, on the other hand, the weight to be supported is greater—for example, two

hundred and ten grammes—then the reacting vertical force of the air resistance must be made equal to the weight. This is possible without changing the direction of the plane or its angle with the horizon, if only the velocity of travel, and thereby the resistance of the air, can be correspondingly increased. If, however, we must maintain the same velocity, then, in order to increase the resistance and the consequent vertical supporting force, we shall be obliged to increase the angle with the horizon to twenty-five degrees. This will, it is true, carry the weight, two hundred and ten grammes, but the retarding resistance of the air in a horizontal direction will in like manner increase—that is, to ninety-five grammes—and the horizontal velocity will decrease. The angle of twenty-five degrees is thus less favourable than one of ten degrees. In the case of a bird, the loss of velocity always increases, and especially as a result of its need to maintain its position against the force of gravitation. In this it can indeed often succeed only by flying faster, and in that case meeting less resistance to its progress because it cuts the air at a sharper angle. It will also lose less of the momentum which has been accumulated in its mass by the increased action of the wings; while it results from this that it requires in full flight less effort for greater velocity than seems to be needed for less velocity.

It is to be considered, further, that when the bird flies upward the air is not brought under a pressure of the upper side of the rising wing. If, indeed, the air

were so pressed by the upper side of the wing from below upward an upward current would be produced. This, however, is not the case, for birds which fly upward with great velocity turn their flight feathers on their axes with wonderful skill, so that they cut the air and create no pressure. If, however, the bird is in full flight, then the turning of these feathers does not take place. Neither does the folding of the wings with which it is automatically connected; so that the air pressure on the upper side of the wings is dependent on—

1. The relative velocity of the wind.
2. The rapidity of the lifting of the wings.
3. The slope of the surface of the wings.

The vertical reacting force of the air resistance under the wings is regulated by the stroke, and this has also been shown by various experiments.

CHAPTER XII.

SAILING FLIGHT.

THE sailing flight of birds corresponds in many respects with hovering. It is possible only when the wind can act on the under side of the wings. If there is no wind, then the sailing bird must propel itself through the air by the action of its wings, for it can fly in no other way.

Sailing flight is confined to particular birds which are, physically, peculiarly constituted for it. Those best adapted for it have long, narrow, flat wings. For this flight often only a light wind is required, as is seen in the case of the frigate-bird and the Carolina kite, which fly in regions where, according to Barté, the air is comparatively calm. In regions where the wind is stronger, only such birds can sail as have wings of much less surface, as the common and larger gulls, storm birds, and vultures.

The existence of wind is, nevertheless, an absolute requirement for sailing flight; and while it has been thought that birds were seen to sail in still air, it is highly probable that while a calm reigns at the surface

of the ground there must still be a wind in the higher strata where they are.*

It is, however, to be remarked that many mechanics have denied the possibility of this flight, and have considered it to be as chimerical as perpetual motion. They considered that the name "sailing flight" indicated an incorrect comparison, and that the bird in no wise fulfils the conditions of a sail-boat. In this, however, they were wrong, and it is fair to suppose that they had never observed sailing flight correctly, for much resemblance is to be observed between the sailing of boats and the sailing flight of birds. It is only necessary, in this connection, to take account of the condition: that the wind strikes the sails of a boat from the side, and the wings of a bird from underneath.

The wind which strikes the sails of a boat or the wings of a bird at an acute angle is reflected from the surface of either and flows away. It thereby creates a counterbalancing force or reaction which sends the

* According to Barté, sailing flight on a wind of from three to five metres per second (four and a half to seven and a half miles per hour) requires a wing surface of fifty-five to sixty square decimetres per kilogramme of weight, and in a wind of from nine to twelve metres (nineteen to twenty-five miles per hour) a surface of thirty to thirty-five square decimetres; while in a gale of twenty to twenty-five metres (forty to fifty-five miles per hour) only such birds can fly as have wings of twenty-five to thirty square decimetres per kilogramme.—Barté, *Mémoire relatif au Problème de Locomotion dans l'Air, l'Aéronaute*, Octobre, 1872, page 191.

boat or the bird forward in a direction that is more or less different from its own.

The sail-boat can sail so close to the wind only because its keel prevents it from leaving its course; or, in other words, it is thereby kept from giving away before the force of the wind. The action of the air on the wings tends, according to their angle, to turn the course of the bird upward, and this tendency, which is called lifting propulsion, is more or less counterbalanced by the force of gravitation, according as the bird desires to maintain the same height or to fly higher or lower. The equivalent of the effect of the rudder, by which a sail-boat is kept from falling away from its course, the bird possesses in its tail, which it uses as a rudder and also as a means for changing the position of its centre of gravity. It will thus be understood that the pressure of the wind has a tendency to turn the bird and to tumble it over frontwise, and that this is prevented by simply moving the centre of gravity to the rear. Sail-boats and sailing birds are thus correctly compared with each other; and, in fact, naval officers who have watched this sailing flight acknowledge that the study of sailing gives useful indications for the elucidation of the flight of birds.

Based on considerations of this kind, D'Esterno, as early as 1864, attempted to form a theory of sailing flight. He was of the opinion that birds could not sail against the wind without losing velocity. Other writers, however, have gone further. Mouillard had ob-

served birds which were able from a state of rest in the air to rise and go forward against the wind without a stroke of the wings.

According to Audubon, the frigate-bird can make head against a storm and hold its own position without falling back. He also says that storm birds can rise against the wind. Marey has likewise seen large gulls begin with a sailing flight against a very strong wind, though they then made very slow progress. According to the testimony of all writers who have observed the vertical rising of a bird in the face of the wind, this manœuvre requires a stiff breeze. If the wind is light, then, according to Mouillard, the bird rises with a spiral course. A circular line of travel therefore admits of sailing flight in a breeze that is too light for a rectilinear course. By means of such circling the eagle maintains itself at a great height in the thin air. One was observed by Humboldt himself at an elevation of seventy-three hundred metres (twenty-four thousand feet). Under these circumstances, I trust that the theory of D'Esterno may be left to the future with its further investigations.

In this connection I think it will be well to say a word about the parachute, which belongs in a greater or less degree to the outfit of the balloon. With the parachute, courageous aëronauts—in one case a woman—have ventured to leave the car at a giddy height and descend to the earth. The parachute opens with the fall, and when opened it meets so much resistance

from the air that the ground is reached slowly and without danger. Hanging from the parachute, a man soars or sails downward and assumes in many respects the conditions of soaring or sailing bird flight. He can, in full compliance with the rules for sailing a boat, determine the direction of the descent, and fix with considerable accuracy the point at which the landing shall be made.

CHAPTER XIII.

THE LAW OF AVANZINI.

THE centre of air pressure takes different positions under the wings of the bird, according to the law of Avanzini.

When a bird stretches its wings out horizontally to descend vertically from an elevation, the centre of bearing of the wings and the centre of air pressure coincide. As soon, however, as the bird moves rapidly in a slanting direction the centre of air pressure is transferred to the hinder part of the wings, more and more so in proportion as the flight becomes faster and as the angle of the wing surface with the direction becomes sharper.

This transferring of the centre of air pressure was discovered by Avanzini in his experiments relative to the resistance afforded by water when planes are moved in it at different inclinations.

De Louvrié supposed that in the moving of a plane in a slanting direction through the air a resistance corresponding to that encountered in water must be created. This is confirmed by the observation that a bird soaring through the air at great speed carries its wings and con-

sequently its centre of gravity to the rear. In this case, in order that the equilibrium may not be disturbed and that the bird may not lose its balance, it follows that the resultant of the air pressure must not fall on the centre of the bird, but must also be transferred to the rear. Cayley has in like manner maintained that this transferring of the centre of air pressure takes place whenever the wings are carried at a very acute angle with the direction of flight.*

It also appears from the observations of M. Mouillard that the direction of the wings is modified in accordance with the velocity of soaring or travel. Birds that soar very slowly carry their wings to the front, so that they

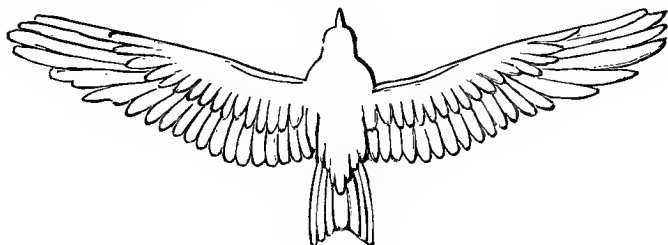

FIG. 8.

form an angle within which the head is placed as shown in Fig. 8. Other birds which fly rapidly carry their wings, on the other hand, to the rear, so that they form an angle in front as shown in Fig. 9.

The changing of position of the centre of air pressure

* *L'Aéronaute*, 1877, p. 260.

under the wings of a rapidly soaring bird may suggest the thought that a loss of balance is possible. Against this danger the bird is able to provide in several ways; the tail, which acts as a rudder, may be turned vertically upward, the wings may be carried backward, or, finally,

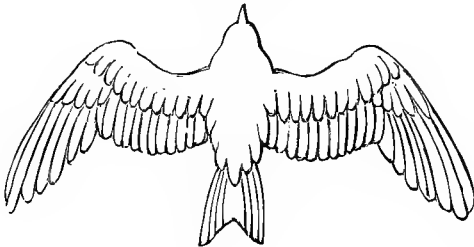

FIG. 9.

the neck may be stretched forward. The last is, for example, to be seen in the case of the heron, which in normal flight draws in its neck and holds its head between its shoulders, but which when pursued by a bird of prey stretches out its neck and therewith increases its speed.

The more the centre of gravity is thrown forward the greater is the velocity of flight. This assumption is based not only on what is observed in the case of birds, but is also deduced from a series of observations with hovering planes. Previously to these observations it was attempted to reduce the hovering of birds to the simplest form. A square of paper was with this view bent in the middle so as to form an angle with two equal planes. In the fold or angle a light needle was fastened with a little

wax, and this was loaded at the ends with small balls of equal weight, so that when the apparatus was hung from the middle in a horizontal position it was perfectly balanced. As the centre of gravity now lies in the angle and midway of the length, if the object is allowed to fall, the outer edge of the fold will remain horizontal and will be the lowest, as shown in Fig. 10. When, however, the ball is removed from one end and the centre of gravity is thus transferred towards the other end, the

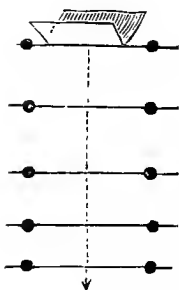

FIG. 10.

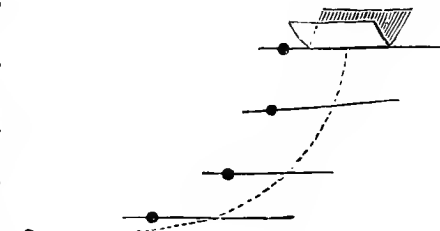

FIG. 11.

object floats in a slanting direction, and descends with increasing velocity towards the ground in the manner shown in Fig. 11.*

The apparatus may also be made to assume a vertical position as it descends, as when both leaves of the bent sheet are turned down at the upper rear corner as in Fig. 12. That is, the object, apparently in opposi-

* It is also asserted that a similar phenomenon is to be observed in the steering of a boat.

tion to gravitation, is seen at a given point of its side-long descent to turn upward, which is accompanied with a loss of velocity of movement. This has been explained by the fact that so long as the apparatus in descending had attained little speed, the influence of

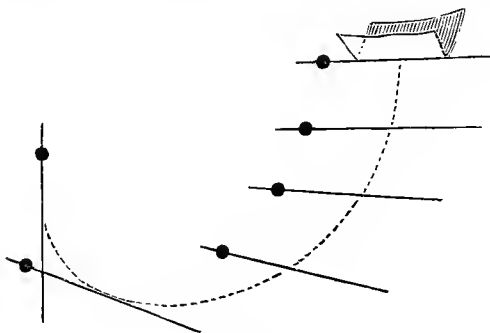

FIG. 12.

the curved course had not much effect; but, as the speed increases, the apparatus acts as under the influence of a rudder and turns upward, as shown in the figure. The force of gravity which had caused the increasing velocity in the descent acts after the turning as a retarding influence, so that the object is brought to a standstill.

With a height sufficient to permit the experiment, a second descent will follow, and a series of revolutions may be observed before the apparatus reaches the ground.

If the paper is arranged as shown in Fig. 13, with curved instead of flat wings, then the apparatus will be

seen at a certain point, after descending a little, suddenly to change its course and to fall heavily towards the ground. In this case, at the moment when the rudder-like action was exhausted, the new direction was helped by gravitation, aided rather than hindered by the descent, as in the former case.

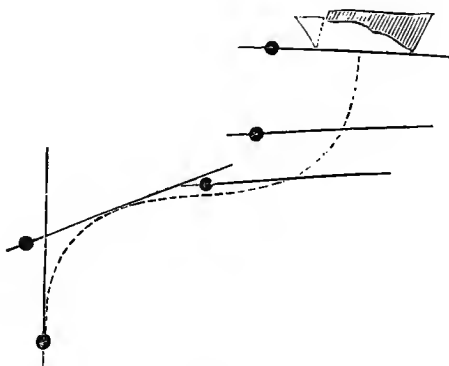

FIG. 13.

The movements of this little paper contrivance have much resemblance to those of birds, and were it possible during its descent suddenly to change the shape of the leaves, we might imitate the downward sweeping and the upward turning of the falcon, as described in Chapter XI.*

* Soaring devices are made of various shapes and forms. The *aéroplane* described by Cayley descended with a weight of two hundred pounds from the heights to the plain at an angle of ten degrees with the horizon. Pline constructed, twenty years ago, curious light toys in the form of birds and butterflies, which, by the bending or extending of the wings, thus slightly changing

The importance of a close study of the little appliances which imitate mechanically the flight of birds may now be generally understood. Artificially contrived appliances of the character of those prepared in 1875 and 1877 by Alphonse Penaud and Tatin have recently been taken up by Pichancourt, whose mechanical birds, weighing twenty-five grammes, with waving wings 0·35 metre wide, and with India-rubber feathers, worked with great regularity. These appliances can with a slow rising make a flight of some twenty metres' length. A larger machine, weighing six hundred and seventy-five grammes, when started forward by the hand, reached by its own movement a height of twenty-eight metres, and a distance of twenty-one metres against the wind, notwithstanding its velocity was four metres per second (over eight miles per hour). These small mechanical appliances, it is true, are intended chiefly for toys, but their regular working gives them an unmistakable value for experiment and observation.

the centre of gravity, can be made to take on various movements, going fast or slowly, smoothly or by fits and starts, and finally straight or on a sweep. The movements of these little toys were, because of their lightness, very slow, as the action of gravity which gave them their motion was slight as compared with the resistance of the air. Still, it was impossible, by reason of their slow movements, to follow all of their various changes with the eye or to distinguish all of their accelerations and retardations during their course, which must be seen with accuracy in order to understand soaring flight practically. This difficulty has now been overcome, since photographic observations of soaring devices have analyzed and determined them.

CHAPTER XIV.

THE EXERTION OF FORCE BY BIRDS.

THAT birds consume or exert any force at all in their soaring and sailing flight has often been doubted. According to Mouillard, the old falconers observed that falcons which sought to capture their prey, and in rising flew out and back, exerted no force in the manœuvre, though this seemed to be the case at first sight. They convinced themselves of this by watching the breathing of the birds, which was little if at all accelerated beyond what it was when only a few moments' use had been made of the wings.

The falconers likewise thought that the bird was also, so to speak, refreshed by the strong air currents in which it had been roaming. The truth is, however, that they had performed only the slightest mechanical work.

As artificial bodies, corresponding in form with the bird, properly balanced in the air, glide or float, and, in proportion to the height at which they are released, travel over considerable distances, so it appears that these movements, which compare exactly with soaring flight, require no exertion of force; gravitation alone

does the work in this case, which is shown by the decreasing elevation of the object above the ground, according to the distance that it has travelled in its floating.

Sailing flight is especially distinguished by a series of soaring and "rowing" movements. The force of the wind is here the source of power. In "rowing" flight the pectoral muscles of the bird perform a negative work. These great muscles offer a resistance to the lifting of the wings, but they yield to the force of these movements, and finally give way under it; just as a man who takes a heavy object from a high place and sets it on the ground, when his muscles are strained against the weight, but in reality yield to it.

In soaring or sailing flight the bird has, theoretically, exerted and consumed no force, because it performs only an imperceptible movement in changing its centre of gravity. Meanwhile it holds its wings outstretched in both soaring and sailing, so that the entire weight of its body is upheld and supported by the resistance of the air. The bird is, therefore, not inappropriately likened to an athlete, who, with straightened outstretched arms, is able to hold himself up between two points of support, although the whole weight of his body is bearing upon them. In this case, also, no work, or at least no perceptible work, is done, for the position of the body is not changed; yet the enormous exertion of strength required under this strain is evident from the fatigue that follows.

The bird, when soaring or sailing, exerts a force which may be compared with this—that is, it carries the weight of its body between its two outstretched wings, whose points of support are at the centre of the air pressure under them. Now, these centres of pressure may, in soaring or sailing, lie much nearer to the body of the bird than in “rowing” flight. Yet the force required for this flight is much less than that exerted by the large muscles of the breast in supporting the soaring bird. It is, therefore, very important to inquire whether or not the pectoral muscles of sailing birds have something special in their arrangement and operation that enables them to sustain the required exertion.

CHAPTER XV.

ATMOSPHERIC CURRENTS.

IT is true that we can draw inferences as to the direction of winds, and as to storms, from barometric variations, or from the atmospheric pressure at the surface of the earth; but no correct idea can thus be formed of the currents which may prevail at different elevations, resulting from the increasing rarity of successive strata. With regard to this we are wandering in complete uncertainty, for it has not yet been possible to determine the influence of this rarity by observations. A contrary belief formerly prevailed quite generally, that in the higher strata the currents had fixed directions which could be made serviceable in aërial navigation; and that at different elevations, currents, and counter-currents existed, which would serve for going and coming in different directions. Though I doubt it very much, still the possibility that such currents exist can as yet hardly be contested with absolute certainty when we consider the trade-winds and monsoons that exist elsewhere. Before we can assume that they are so general, they must first be established by observation and demonstration. The currents in the strata cannot, however, be tested and

determined without the aid of balloons or other means of traversing the air, for observations taken from the surface of the earth as to the direction of the movement of clouds are still very uncertain.

Observations with appliances made for determining the force and velocity of the wind at the surface cannot be used for studying the movements of the upper air, because the observer is immersed in this and is borne along with it, while the anchoring of a balloon at a great height has never yet been accomplished. The importance of an exact knowledge of the meteorological conditions of our atmosphere cannot, however, be denied, but, as the foregoing remarks indicate, there are great difficulties in the way of making observations in the boundless air. It is worth while, nevertheless, to call attention to observations made at about the same period by Gay-Lussac in his scientific experiments with the balloon in 1804, and by Saussure and Von Humboldt in high Alpine regions. In later times many observatories have been built on high peaks, and in their balloon ascensions Messrs. Glaisher, Gaston, and Tissandier rendered important services to science. The question has, therefore, presented itself as to the manner of observation to which the greatest weight should be given in seeking general knowledge of atmospheric phenomena.

Concerning this, however, there seems to be no room for doubt that the condition of the atmosphere on high mountains, in view of the temperature, the hygrometric conditions, and the state of the wind, differs very much

from that in the free air, so that the preference is to be given to observations by which the free, high air can be reached.

Meanwhile there are already sufficient indications that meteorological observations taken on the Eiffel Tower in Paris, where not only the horizontal but also the vertical or up-and-down movements of the air are being studied, will be of great value. In June, 1889, an anemo-cinemographic apparatus was set up there by which to observe the direction and the mean force of the wind. A second and more complete apparatus, made by the Brothers Richaud, was set up in October, 1891, by which the vertical movement was given by means of a small wheel with four wings or screw blades set, at a pitch of forty-five degrees, on a vertical axis, and running in either direction, according as the resultant of the air current is upward or downward, while it stands still under a horizontal wind of even the greatest velocity.*

According to the new apparatus, on November 23 and 24, 1891, this velocity reached thirty-four metres

* Ordinary anemometers seldom suffice for these conditions. They necessarily lead to the inference that the air pressure exerted on the opposite wings will have the same velocity. In order to obviate any source of error, or effect of external conditions, the apparatus now used is placed in the axis of a vertical cylinder twenty-five centimetres high (ten inches), which is open above and below; it is thus protected against the direct action of horizontal currents, and seems to give satisfactory results. The velocity of the wind is shown graphically on a strip of paper, which unwinds at the rate of three centimetres per minute.

per second (about seventy-eight miles per hour) on the morning of the 24th, and in less than thirty seconds fell off to 19·9 metres per second (from seventy-eight miles to forty-five miles per hour). The pressure, which is as the square of the velocity, was thus reduced to about one quarter in half a minute.

In this time the anemo-cinemograph gave the average velocity during a period of one minute as 26·3 metres (about fifty-eight miles per hour); while the same apparatus, on January 23, 1890, indicated thirty-two metres per second (about seventy-two miles per hour); so that it was considered probable that the greatest velocity reached was forty metres per second (ninety miles per hour).

Thus far, the greatest vertical velocity on the Eiffel Tower reached about 6·8 miles per hour (more than three metres per second), on the 24th of November, 1890, between 10.30 and 11.30 in the morning, with a rising wind. The horizontal velocity in the same time reached 18·8 metres per second (about forty-one miles per hour), giving, as the resultant of both of these velocities, an increasing force with a velocity of nineteen metres per second (about forty-two miles per hour), with an angle of nineteen degrees with the horizon. The observations on the Eiffel Tower have not continued long enough for laws or inferences as to the general conditions of the atmosphere to be deduced from them; so that I think we must limit ourselves to these conclusions:

1. Descending currents seem to be less frequent than rising currents, and to have less velocity.

2. Every rapid and continued fall of the barometer is accompanied by a more or less rising current of from two to three metres per second (about four and a half to six and a half miles per hour). The horizontal current is then also strong, the sky is covered, and the change of temperature is slight, so that the rising current cannot be ascribed to the influence of an increasing temperature of the tower itself. This occurs by night as well as by day.

3. The relation of the amount of the resultant of the horizontal and vertical force of the wind under different conditions cannot yet be sufficiently indicated. The vertical velocity during the storm very often increases, however, during the brief moment of calm following the blast.

4. The currents always rise during a rapid fall of the barometer. During a rising barometer they sometimes rise and sometimes descend. The investigation of these phenomena will probably yield important results when a sufficient number of observations to that end shall have been collected.

5. The longest periods of descending currents have been observed during very rapid rising of the barometer, or during continued high pressures. There have also been observed during such conditions successive descending and rising currents, each continuing several hours.

CHAPTER XVI.

THE APPLICATION OF THE PRINCIPLE "LE PLUS LOURD QUE L'AIR."

THE principle "*Le plus lourd que l'air*," which was considered in Chapter I, has many firm partisans. These have not failed to urge their opinion for practical application, and it was further advanced by the construction of several floating appliances.

These appliances were generally very different, and were of various kinds. They may be grouped under three classes :

1. The screw flyer (helicopterous).
2. The straight-winged (orthopterous).
3. The aëroplane.

The first apparatus of the screw character (helicopterous) was originally advocated by Vicomte Ponton d'Amecourt, Lalandelle, Nadar, Forlamini, and others. It was based on the application of one or more screws with vertical or slightly inclined axes operated by a sufficient motor.* The screws were depended on to de-

* The first idea of this movement had already been set forth in an apparatus submitted to the French Academy in the latter part of the last century by Messrs. Lannoy and Bienvenu.

velop the resistance or motive power in the air which was intended to support the apparatus and also to move it forward.

Small toys made according to this plan were able to maintain their position in the air for some moments. When, however, account was taken of the power required to operate these screws in the air, it was soon seen that no motive force as yet available would suffice for the support of the necessary weight. The vertical force developed in the shaft of the screw must at least equal the weight of the apparatus to be supported and propelled. According to the calculation of Drzewiecki,* however, this force applied to a horizontal screw would suffice to support and propel an aëroplane loaded with twenty or twenty-five times more weight than could be allowed in the case of a vertical screw machine. The operation of the last-named screw apparatus, therefore, from the point of view of useful work, was very unsatisfactory.

The second or straight-winged device (orthopterous) aimed at an imitation of the rowing flight of birds, according to the earlier conception of their movements. It had two or four horizontal inclined wings, which were set in motion by a light motor, and which, in order to support the apparatus, must be successively

* See the various writings of S. Drzewiecki; among others, *Les Oiseaux considérés comme des Aéroplanes animés* and *Le vol Plane*, published at Paris by E. Bernard & Co. The first paper is out of print and I have tried in vain to get a sight of it.

raised and lowered. By this means the propulsion by the inclination of the wings and the direction of the movement by the tail were secured. In the first application the wings were so arranged that, like the slats of a window-blind, they opened in rising to obviate the downward resistance of the air. It was fancied that this would correspond with the action of the wings of a bird. The erroneous opinion was entertained that the flight feathers of the bird turned in their places when the wings are lifted, so as to let the air pass through freely. According to the investigations of Prof. Marey, this earlier interpretation can no longer be maintained. It is shown in Chapter XI that the flight feathers turn on their axes only when the bird flies rapidly upward—not when it is in full flight. Greater attention must therefore also be given to the movement of the wings themselves, which during a descent are moved more to the front, and during an ascent to the rear, describing in their movement a sort of inclined ellipse; the lower edge of the wing is directed a little to the rear in descending, and to the front in rising.

If we take account, further, of the resistance that a plane of the size of a bird's wing encounters in the air when it is depressed as rapidly as it is in practice, the amount of the resistance will be found to be far below the weight of the bird, which indicates an absurdity.

Calculations based on the unit of time are, as is shown in Chapter X, not to be relied upon. Finally, Drzewiecki has observed that the insufficiency of the

normal centre of support of the bird can be shown by direct proof if a plane of the size of a wing is moved up and down with the rapidity of wing-strokes.*

These calculations and experiments had seriously disturbed confidence in the theory of the straight-winged apparatus (orthopterous). The important deductions of Marey, set forth in Chapter X, that the resistance of the air due to the downward stroke of the wings increases as the speed of the bird in a horizontal direction becomes greater, had, however, been left out of the consideration. From this Drzewiecki deduced, in 1885, the principle that the descending wing during the flight of a bird assumes the condition of an aëroplane.

The movements of the bird had always been studied under the supposition that it could hold itself motionless in the air; and no account was taken of the moving of the bird itself, although the velocity of this progress is much greater than that of the wing-strokes. If, according to the indications of Prof. Marey, we combine the movement of the wings throughout their whole sweep with the forward movement of the bird, then it appears that the upper side of the wing stands at an angle with the horizon both in rising and in descending, and that this angle is substantially constant. The wing is thus converted to the condition of a movable aëroplane, and the under side of the body and tail of the bird to that

* Communication of Drzewiecki to the Imperial Technical Society of St. Petersburg, April 13, 1885.

of a fixed aëroplane. Therefore, if account is taken of the rapid forward movement of the bird, then it appears that the straight-winged system of flying machines in correct relation to bird flight resolves itself, as it were, into the aëroplane system; and the first or screw flying system assumes the same character. The three systems so far correspond as to appear as one; while together they represent the principle "*Le plus lourd que l'air.*"

We must henceforth regard the bird as an animated aëroplane, which makes it possible that we may be able to determine the mechanical laws governing artificial flight, and that we may indicate the way by which we shall reach the result of aërial navigation through an investigation of this aspect of the question. We must therefore also consider the aëroplane with regard to its mechanical construction, the dimensions of its bearing surface, its conditions and velocity of movement, the weight to be carried, and the proportions of the supporting surface to this, the angle with the horizon of the plane itself and of its line of travel, the motive power required to secure the movement, etc. Furthermore, in forming a theory of the aëroplane, it is necessary to take accurate account of all questions relating to the conditions of equilibrium, and to consider also whether or not the observations of bird flight and the resulting calculations made always accord with the inference deduced therefrom.

For such scientific investigation we must start with a simple supposition: that a horizontal aëroplane moves

in a direction which, under a certain angle with the horizon, creates a resistance in the air that is perpendicular to the plane. This resistance is, therefore, a function of the size or dimension of the plane, of the velocity of its movements, and of the angle with which the air comes in contact with it. It may, therefore, according to Chapters IX and XI, be separated into a vertical impulse and a horizontal force which offers a resistance to the movement.

The flight of birds is also subject to this law: they cannot maintain their position in the air without great speed.* The correctness of these theoretical considerations cannot well be disputed, yet their practical application is difficult because of the lack of correct data as to

* The normal speed of birds increases with their weight and decreases with the increase of the spread of their wings.

Ducks, which sometimes weigh eleven kilogrammes per square metre, are obliged, in order to sustain themselves in the air, to fly with much greater speed than swallows or larks, whose weight per square metre is not more than 1.5 kilogramme. The swallow, the pigeon, and many other birds, reduce the surface of their supporting planes as they increase the velocity of their flight, folding the wings and tail; when it is to be observed that the tail is not used as a rudder, but as an auxiliary sail.

In the absence of the requisite velocity, birds cannot rise, as is well known to sportsmen, and as is clearly shown in the experiments of Marey, given in Chapter X. If the bird in its flight does not attain its normal speed, it then stretches out its wings to the utmost and spreads out its tail like a fan. If it has, on the other hand, attained speed enough, then the wings are reduced to the average spread, and the tail is closed. Drzewiecki concludes that, according to the theory of the aëroplane, the work performed by the bird in flying does not exceed the muscular effort of other animals.

the resistance encountered in a fluid medium by surfaces moving in an oblique direction. Nevertheless, it is possible, with the aid of the empirical formula of Colonel Duchemin, to calculate a table of weights which a horizontal aëroplane can carry per square metre, moving through the air at different velocities and at different angles; also the power required to propel the plane at the same velocities and angles. From these tables it has been deduced that the greatest amount of work with the least consumption of power coincides with an angle (of incidence) with the horizon of $1^{\circ} 50' 45''$, which is called the "optima angle." Further observations and computations will probably establish this angle as the correct one, and, according to Drzewiecki, will lead to the following inferences:

1. That the carrying power of the aëroplane is a direct consequence of its forward movement at a slight angle with the horizon, and originates in the vertical force created by the resistance of the air.

2. That the work done in floating becomes directly available for horizontal propulsion.

3. That so long as the position of the plane is maintained at the optima angle of incidence during the horizontal movement the apparatus must have a uniform speed, which is called the normal velocity, and is dependent on the weight of the plane, so that a heavy apparatus must move faster than a light one.

4. That the expenditure of force required for forward propulsion corresponds with the normal velocity

and the weight of the apparatus, so that the resistance during the movement, per unit of load, is constant for the normal velocity and the optima angle. Drzewiecki estimates it from four to five per cent of the weight of the apparatus, so that the horizontal force of one kilogramme should yield a duty of twenty to twenty-five kilogrammes.

In the movement of the aëroplane the maintaining of its stability or of its dynamic equilibrium is to be regarded as of great importance. According to the observations of Avanzini (see Chapter XIII), and also according to the direct observations of Joëssel, the centre of the resistance is transferred towards the front when a plane under changing angles of constantly increasing acuteness is exposed to the pressure of running water. This transference is sufficient to maintain substantially the equilibrium of the plane, because the force of the resistance and of the movement, acting on different points, form a couple which gives the plane a proper angle. In this connection we may refer to the various observations and experiments made by Langley at Washington, Maxim at London, and Lilienthal at Berlin, and we may therefore count on seeing this question brought to a solution, which, however, will meet serious obstacles because of the considerable expenses required for such experiments.

CHAPTER XVII.

CONCLUSION.

FROM the foregoing statements and considerations we arrive at the following results as to air balloons:

1. That in 1855 Giffard tried to improve the art of aërial navigation by a considerable increase in the length of the balloon, which, however, resulted in great difficulties and disappointments. To this there was applied a motor which gave a propelling force of 3·82 horse power per assumed unit (one hundred square metres) of cross section.

2. That in 1872 Dupuy de Lôme contributed important improvements with a view to increasing the stability of the balloon, and applied a small motor of 0·65 horse power, with a propelling force of 0·38 horse power per unit of cross section.

3. That in 1883 Tissandier also resorted successfully to a certain increase of the length of the balloon, and applied a propelling force of 2 horse power per unit of cross section. And, finally—

4. That in 1885, by means of several improvements, there was found to be no difficulty in re-establishing nearly the increased length of the balloon attempted

by Giffard in 1855; and that with a motor of one quarter the former weight there was obtained a propelling power amounting to eight times that of Tissandier. Furthermore, the balloon of Renard and Krebs, made at the arsenal of Chalais, attained the important result that in seven ascents a return was five times made to the point of departure, showing that they five times had complete control of its direction. A speed of 6·5 metres per second (about fourteen miles per hour) was reached, showing that, according to the table in Chapter V, it may be fairly estimated that during four hundred and fifty hours out of one thousand this balloon could, with more or less completeness, be driven in any direction. As compared with the results of 1884, the speed was nearly doubled, and the motive force was carried to nearly eight times that of Tissandier.

These results are important, for in aërial navigation velocity is of much more consequence than lifting power, which for many reasons is always limited. In aërial navigation, as is shown in Chapter V, we can control direction only by velocity; and, indeed, it has also been shown that the flight of birds is especially dependent on velocity. It further appears, from the communications of Commandant Renard, that an effort is now being made at Chalais to double the velocity, and so to carry it to thirteen metres per second (about twenty-nine miles per hour). If, in strict accordance with Chapter V, it is assumed that a velocity of 12·5 metres per second (27·96 miles per hour) is sufficient, and that

the power of the motor is as the cube of the velocity, then we have for the increased velocity of the Chalais balloon a power of $8 \times \frac{12 \cdot 5^3}{6 \cdot 5^3}$, or about fifty-seven horse power, which is a very satisfactory result.

Applying again the tables of Chapter V, we can estimate approximately that with this speed during eight hundred and fifteen hours in one thousand we may move in any direction, and we may count on a speed of twenty-five metres per second (about five and a half miles per hour) during seven hundred and eight hours in one thousand. In view of the exceptionally competent opinion of Commandant Renard, I do not doubt that such a speed can be attained. It is not necessary to adhere exactly to the dimensions and arrangements of the Chalais balloon, and we may even secure an increase of speed by various improvements. In spite of all this, the weight of the motor required for such great power must constitute a serious embarrassment, and, with due respect for the opinion of Renard, I venture to think that the solution of this difficult problem is perhaps not to be expected at an early date.

A balloon in moving against the wind is further exposed to the combined influence of the two opposed forces, with the great velocities of thirty-six and nine kilometres per hour. Even if able to withstand this, the velocity now secured cannot be regarded as sufficient for the future; and so the question comes more and more seriously to the front, whether or not a balloon

constructed of light material can be so made as to resist the combined force of the air pressures. Thus far this may be greatly doubted; and though the expectations of Commandant Renard may be satisfied up to a certain point, still the truly magnificent aim of navigating the air with balloons may not yet be reached, because they cannot be propelled with sufficient velocity to meet all conditions of wind. This does not mean that the continuance of the observations of Renard and Krebs on air balloons is not much to be desired at this time; for the scientific results to be expected from their investigations will benefit not only the art of ballooning, but that of aërial navigation generally.

Under these circumstances we may anticipate that the balloon will give place to flying machines made on the principle "*le plus lourd que l'air*," which has the advantage that we shall be no longer dependent on the limited time to which the use of gas with balloons restricts us. We must, however, in the application of this principle, at the outset keep it clearly in mind that the apparatus must be as light as possible, and that it must be driven at the highest possible speed. We must, furthermore, consider closely the laws regulating the flight of birds, and apply them more and more accurately as continued investigation develops them. Constructors, however, need not disturb themselves as to this. We already know, especially from the scientific investigations of Prof. Marey, how Nature has outlined the solution of the problem in the flying of birds; and it is

evident that in the application of natural laws to aërial navigation we cannot follow them blindly. Drzewiecki has very justly observed that birds perform two very distinct operations with the same organ; for the wings, by a wonderfully simple combination, form both an aëroplane—the extent of whose surface, whose position and whose angle are changed at pleasure—and a motive power whose greater or less activity is under control. Birds, also, when descending towards the earth, can draw in their wings without in the least endangering their safety.

This is very remarkable, and worthy of close study. For the present I shall be excused if I confine myself to the remark that the combination of these different conditions in a single organ is necessary to the bird in view of the natural laws relating to vertebrate animals. Alternate or “rowing” flight has been shown in the case of small birds to possess advantages which it has not in the case of larger ones with long wings and great weight. This is also the reason why large birds confine themselves especially to sailing and hovering flights. For this, no continuous propulsion, and consequently no up-and-down movement of the large wings, is required, and wing-strokes in the case of such birds seem to call for much exertion.

From the indications of Drzewiecki it further appears :

1. That a heavy flying machine must clearly be supported by an aëroplane of considerable dimensions.

2. That this aëroplane must not be used as a motive force, while the power developed by the different "rowing motions" would, because of the low velocity, be very slight. Furthermore, that the construction of this aëroplane would have to be very strong, giving considerable dead weight.

3. That, according to the foregoing, it will be well, in any case, to provide a special motor, working uninterruptedly, as, for example, is the case with the screw propeller.

4. That in the movement of the (rowing) aëroplane it would necessarily result that the mutual relation of the centre of air resistance and the centre of gravity would be continually changing, which would endanger the stability of the apparatus. This change is, in the case of the bird, constantly regulated by the sinews; while with a flying machine it would require a very complicated automatic apparatus, which, even with the most extreme sensitiveness, could never be compared with the perfect combination of the living bird.

With an immovable aëroplane and independent propelling screws, the varying positions of the centres named will, on the other hand, become fixed, and the stability of the aëroplane can be secured for a determined angle.

Drzewiecki has, therefore, recommended for the construction of the flying machine a simple aëroplane comparable to the outstretched wings of a large soaring bird, placed on a framework with wheels on which it

may be rolled along until it acquires the velocity needed to raise it from the ground; also a light motor, sufficient to drive a screw that will support the apparatus in the air. The various movements in the machine due to the changes of the centre of gravity, and the normal velocity, with the force required for horizontal propulsion, must be regulated by bringing the apparatus into a correct relation with the supporting surface of the *aéroplane*.

Very light motors have already been made, and by the use of hydrocarbon compounds an effective power can be produced with little weight; while modern ingenuity has by no means said its last word on this subject.

Moreover, it can no longer be denied that the question of *aërial navigation* has now assumed a really scientific character. It may, therefore, be supposed that the great problem will be carried to a complete solution; still, at the outset, nothing more will be attempted than a flying machine suited to carry only a very limited number of persons. These will be, as indeed was the case in the first navigation of water, only skiffs and small boats, which, however, will be able to render valuable service in meteorological, military, and various other fields, as for postal work, etc. It is, of course, not to be expected that these skiffs will escape the law of the evolution that grows out of necessity, as has been the case with all means of transportation on the earth. At the same time, we cannot, without seeming to paint a

lively picture after the manner of Jules Verne, imagine the growth of these skiffs into vessels carrying valuable freight or into war vessels and monitors, so that the wish must involuntarily come to our clever sailors that it may be granted to them to sail in air ships to higher spheres.

In conclusion, may I further observe that rapid travel in the free air need encounter no serious difficulty!

ARCACHON, *May*, 1892.

EXTRACTS FROM A LATER PAMPHLET
BY MR. FIJNJE.

AFTER the publication of his original pamphlet, the author received a copy of *Experiments in Aëro-Dynamics*, by Prof. S. P. Langley, of the Smithsonian Institution, and, based on this and on other more recent writings, he wrote a second pamphlet as an extension of it.

The new pamphlet begins thus: "Since the appearance of my first observations on aërial navigation, this subject has made an important advance, especially as a result of the investigations of Prof. S. P. Langley, of Washington. Recurring to what I then wrote, I am glad to see that I need to retreat from none of my former conclusions, and that, on the contrary, I can maintain them without fear. The agreement is remarkable between the conclusions that I advanced and those which Prof. Langley has set forth in his important experiments, and which appear in his paper on *Mechanical Flight*."

[The following extracts from this more recent publication relate largely to details of Prof. Langley's experiments. They are followed by somewhat copious ex-

tracts, of a general character, from Prof. Langley's own report.]—*Translator*.

In considering the various opinions as to soaring and sailing flight, I am met by an insurmountable difficulty when I try to regard the two methods of flying as one, according to the German students of the subject. In relation to this I cannot accord the same value to the German opinion as to that which seems to have been developed by Prof. Marey. In support of this statement, I will recall from my earlier pamphlets only :

1. That soaring flight takes place only in a calm, and must be due to and maintained by the weight of the bird ; and, on the other hand—

2. That sailing flight is possible only with preferably the strongest practicable wind, and is impeded by the gravity or weight of the bird.

Now, the result of both of these methods of flight may show great apparent similarity, but, on comparing the directly opposite causes to which the two are due, I can conceive no clear idea of their identity. Neither can I agree with the opinion that the flight of birds is not subject to the same natural laws that control mechanical flight. Still, we must not leave out of the consideration the ability of the bird so to exert its muscular power as to cause more or less increase of its weight. Birds also have the important advantage that they can increase their normal speed with their weight, and can reduce it in more rapid flight.

Ducks, which must sometimes carry eleven kilo-

grammes per square metre, are thereby obliged, in order to maintain their position in the air, to fly with much greater velocity than swallows and larks, whose weight per square metre is rarely more than 1.5 kilogrammes. The swallow, the pigeon, and many other birds even reduce the area of their supporting surfaces when they increase their speed by drawing in their wings and closing their tails.

[After referring to the fact that in railway travel heavy trains may be drawn at great speed if locomotives are made heavy enough to develop the necessary friction on the rail, and that in water transportation increased service is secured by the use of larger vessels of suitable draft, the author says:]—*Translator*.

The increasing carrying capacity of railroad trains and of vessels is in proportion to an increase of the size and weight of the means of transportation. Whether or not this principle can be regarded as applicable to aërial navigation cannot now be determined, but it is not likely that mechanical flight can be excluded from the operation of this general law. We are only now justified in expressing a preference for such appliances for navigating the air as are heavier than the air that they displace; but as these find for the development of their capacity no support, as on rails or in water, they will require at the outset great rapidity of movement and the least possible weight in order to maintain their position in the air. We must also consider the difficulty that we are limited in the power we can use for propul-

sion and for maintaining the stability of the floating machine.

The remarkable investigations of Prof. Langley are especially important in this connection. Aërial navigation has thereby been enabled to enter on a new phase, one which must lead to a solution of the question.

These investigations relate in general to the resistance of layers of air to flat aëroplanes, propelled horizontally under different conditions, or which fall by gravitation, and to the air resistance created by the revolving of a propelling screw.

Langley, in developing the velocity desired for his experiments, employed a swinging lever ("turn-table" or "whirling-table") 18·30 metres long. With the use of a ten-horse-power engine a velocity of 30·15 metres per second was given to the end of the lever, equal to about 108·5 kilometres per hour (about seventy miles). The apparatus was arranged for velocities from 4·5 to forty-five metres per second,* and the actual velocity was registered by an electrical appliance. The principle was adopted that when an object is moved through the air at a given velocity it has to resist the same pressure that it would be exposed to in a wind of the same velocity. In accordance with this principle, it was found

* That is, Prof. Langley says: "but owing to the slipping of belts the number of turn-table revolutions was less than this for the higher velocities, so that the highest attained in the experiments did not reach this upper limit, but was a little over one hundred feet (thirty metres) per second, or about seventy miles per hour."—*Translator*.

possible, by the use of extremely sensitive and ingenious appliances, to establish the resistance caused by the horizontal movement, or by the falling of the aëroplanes through the air.

In the experiments the aëroplanes were fixed exactly horizontal, or at various angles with the horizon, and provision was made for observing the time required for a fall through a height of 1·22 metres (four feet).

The apparatus was so arranged that the centrifugal force could exert no disturbing influence. With regard to the other influence that a circular movement might exert, through its effect on the circulation of the air, which can be determined only by elaborate experiments—the formulæ suggested thereon cannot be relied upon—Prof. Langley judged this influence to be negligible, as he shows by an appropriate example, . . . indicating that the difference appears so small that the average pressure on the outer edge, and so much more on the whole plane, may be assumed to be the pressure, and consequently the velocity, at the centre. The principle here involved will be considered further on.

The planes used in the experiments, which must necessarily have a certain thickness, were cut off square. The values obtained from them were thereby easier to calculate, but they were not so favourable as if the angles had been rounded off, or if the thickness had been gradually reduced to a section according with “stream-lines.”

The friction of the air on the surface may, as

was shown by the experiments, be disregarded. It was calculated at $\frac{1}{8000}$ the part of the pressure exerted on the aëroplanes at the speeds under consideration.

From considerations of cost the observations were taken in the open air, and therefore the conditions were most favorable in calm weather, for in a confined building the air assumes a slow movement and forms eddies. In practice, however, the open air is almost never at rest, and the observations were greatly delayed for this reason. An octagonal fence twenty feet high resulted in no improvement, and Prof. Langley advises that at all costs a large, completely enclosed building be used for future experiments. This building should furnish ample space.

It is to be remembered that these observations were undertaken at a time when all the renowned natural philosophers had asserted that the force required for horizontal flight is equal to the sum of that needed to uphold the object motionless in the air and that required to move it against the resistance of the air. According to this, the force required must increase with the velocity of movement.

The opposite, however, is shown by Prof. Langley's observations. In the horizontal movement of aëroplanes of equal size and weight, fixed at such an angle that they would sustain themselves at a given velocity, it was found that the propelling force needed for this movement decreased as the velocity increased, so that

the earlier theoretical considerations would never have led to a solution of the question.

The most important thing to be kept in mind is to be found in the results of the experiments, which are given at length, and concerning which it may be premised :

1. That the velocities were determined by exact observations of the time required for the revolutions (of the whirling-table); and—

2. That the wind pressures were established by exact measurements of the different deviations from the centre, as they were indicated by a recording pencil point, and which are the result of the velocity reached by the end of the lever. To this end the amounts of the deviations were found experimentally by the use of different weights.

Here follows a series of tables of mathematical calculations, for which the reader is referred to Prof. Langley's report.* They relate to trials of aëroplanes of different shapes, set in pairs, the support at the end of the lever being between them. The planes had each, except the last one, an area of half a square foot—one square foot for each pair. Their dimensions were :

6	inches	by	12	inches,	†	weighing	per	pair	123	grammes.
8	“		6	“		“		“	114	“

* See *Smithsonian Contributions to Knowledge*, vol. xxvii.

† The first measurement refers to the advancing edge. In other words, the first two pairs travelled with the narrow edge in front, and the others with the broad edge in front.

12 inches	by	9 inches,	weighing	per	pair	115	grammes.
18	“	4	“	“	“	114	“
15	“	4	“	“	“	118	“

The planes were set level or at various angles with the horizon, they were at rest or propelled at different velocities, and the results are indicated in the tables. For example—with the pair last described in the above enumeration—with a total front line of thirty inches and a width (in the direction of movement) of four inches, the planes at rest and horizontal dropped four feet in 0·69 second. At an angle of one degree and with a velocity of 24·6 metres per second, they fell in 2·20 seconds and then soared. With a velocity of 23·3 metres per second at an angle of one degree, they “fell slowly” (in 6·15 seconds). With a velocity of 20·9 metres per second, at an angle of two degrees, they soared and then fell in 4·15 seconds. With a velocity of 22·8 metres per second and an angle of two degrees, they fell in 5·80 seconds. With a velocity of 23·7 metres per second and an angle of three degrees, they stayed at the top.

In a table to determine “horizontal velocities at which inclined planes are supported by the air,” it is shown that a pair of planes of the third dimensions given, having a front reach of twenty-four inches and a width in the line of travel of six inches, when set at an angle of twenty-five degrees soared at a velocity of 11·0 metres per second, at an angle of six

degrees with a velocity of 16·2 metres per second, and at an angle of five degrees with a velocity of 18·7 per second.

By reversing the position according to the measurement first indicated, giving a total front length of twelve inches and a width of twelve inches, at an angle of

30°,			10·5	metres	per	second ;
20°,	“	“	12·3	“	“	“
15°,	“	“	14·7	“	“	“
13°,	“	“	16·2	“	“	“
9°,	“	“	21·2	“	“	“

From these tables the author makes the following deductions :

1. That the duration of the fall of the aëroplane is greater in proportion as its advancing edge is greater than the width. It is therefore clear that the volume of air of which the inertia is to be overcome by the movement of the aëroplane increases :

(a) With an increase of the edge of the plane that is perpendicular to the line of travel ; and—

(b) With the velocity of movement.

This result is not surprising, and is illustrated by the familiar example of a skater, who at high speed can cross a sheet of ice that would not bear him if standing still ; while ice is sometimes in a condition to bear two skaters moving side by side, when it would give way if one followed the other.

2. That as the horizontal velocity of movement becomes greater, it takes less force to support the object in the air than to maintain its velocity.

3. That the resistance to the air of two pairs of aëroplanes, placed at a sufficient relative distance above each other, is double that of one pair, but that with an insufficient separation, say five centimetres for the planes used, it may be less.

4. That the velocities in these experiments were often grouped under those from 5 to 8 metres, from 12·5 to 13·5 metres, and from 22·5 to 24 metres per second. With a velocity of twenty-three metres per second, the time of falling (four feet) of two pairs of aëroplanes at the respective distances from each other of 15·2 and 10·2 centimetres, was sometimes the same as for single pairs. The case was different when the separation was only 5·1 centimetres.

In order, independently of any formula, to establish by direct observation the fact that the force required for horizontal soaring becomes less in proportion as the velocity increases, Prof. Langley used what he called a self-registering component-pressure recorder.*

A series of tables is now given, for which the reader is referred to *Smithsonian Contributions to Knowledge*, vol. xxvii. The last is as follows :

* For a description of this, see Prof. Langley's report.

Angle with horizon.	Soaring speed. V.		Horizontal pressure. R.	Work expended per minute. 60 RV.			Weight with planes of like form that one horse power will drive through the air at velocity V.	
	Metres per second.	Feet per second.		Grammes.	Kilogrammetres.	Foot-pounds.	Kilogrammes.	Pounds.
45°	11·2	36·7	500	336	2,434	6·8	15	
30	10·6	34·8	275	175	1,268	13·0	29	
15	10·2	36·7	128	86	623	26·5	58	
10	12·4	40·7	88	65	474	34·8	77	
5	15·2	49·8	45	41	297	55·5	122	
2	20·0	65·6	20	24	174	95·0	209	

The author then continues :

A uniform supporting power per square unit is assumed when, with increased dimensions, the form and inclination of the *aéroplane* remain the same.*

The determination of the propelling power exerted by the whirling arm, and the estimate of the amount of useful work there done, could be arrived at only experi-

* Prof. Langley says: "This, strictly speaking, holds good only for a system of planes whose weight, inclusive of any actual motor or other attached weight, is five hundred grammes per square foot of inclined plane surface, and which is made up of 30 x 4·8 inch planes. The experiments with the *plane-dropper* show that in horizontal flight, at attainable speeds, a system of such planes can be made by placing one above the other at a distance of about four inches without any sensible diminution of relative efficiency. Whether these relations of power, area, weight, and speed, experimentally established for small planes, will hold good in the same ratios for indefinitely large ones, I am not prepared to say; but from all the circumstances of experiment I can entertain no doubt that they do so hold far enough to afford entire assurance that we can thus transport (with fuel for a considerable journey) weights many times greater than that of a man."

mentally. Prof. Langley limited his investigations to screw propellers, not because they were the only practicable device for propulsion, but because they seemed to offer the most important advantages for this purpose—and for reasons of convenience. For this investigation he prepared a dynamometer-chronograph, by which the driving force and the actual work done were indicated by a self-registering apparatus, in which three pencil points traced separate lines on a cylinder moved by clockwork.

It was necessary to take into account the renewal of the air in contact with the blades of the propeller, as this has a great influence on the amount of useful work and on the exertion of force in the direction of the shaft or end thrust. If a screw, working on a fixed support, is revolving in still air, a portion of its work will be expended and a certain force exerted in the direction of its axis. If the screw is then subjected to the action of a wind blowing parallel to its axis, then, for the same consumption of power, the end thrust will be increased. There is a perceptible wind in a direction parallel to the axis when the apparatus is driven through the air, and effects observed are greatly influenced thereby. This influence can be measured by a dynamometer placed at the end of the whirling lever.

Prof. Langley first used in his experiments wooden screws with four, six, or eight blades, pitched at various angles; and afterwards two aluminum screws

of twenty-four inches and thirty inches diameter respectively.

The observations, with an aluminum screw having two blades and a diameter of thirty inches, the blades being pitched at an angle of seventy-five degrees with the axis, gave the following results:

Speed of screws, 1,032 revolutions per minute.

Velocity of dynamometer drum, 1,063 feet per minute.

Power developed in the direction of the shaft, 0.20 pound.

Work done, being the speed of the whirling arm multiplied by the end thrust, 373 foot-pounds per minute.

The work done is thus about one half of the actual power.

It is to be remarked in this connection that a screw with two blades has the maximum efficiency (as a propeller in air), in contradistinction to a windmill, where both practice and theory have shown that, so far as is practicable, the whole circle should be furnished with blades.

With a screw propeller, the air is met by each blade after it has yielded to the pressure of the previous blade, and cannot, because of loss of inertia, offer so much resistance as if it were still at rest—as was suggested in my earlier observations on the rowing flight of birds.

The greater the velocity of advance, the less the

amount of back-flow * and the more effective the working of the screw.

.

It would appear from the investigations of Prof. Langley that the resultant of the pressure exerted on a moving plane is perpendicular, and that the following deductions may be made :

1. That less force is required to support a body in the air when it is moving horizontally than when it is at rest.

2. That this force diminishes with the increase of velocity of lateral movement; and that, therefore, the power needed to maintain the soaring of inclined planes will apparently lessen as the velocity increases.

3. That the length of time occupied by the fall of horizontal planes increases as their lateral travel grows faster, and that the time will increase as the edge of the plane that is at right angles to the line of travel is longer than the edges that are parallel to this line.

4. That the power required to maintain the *horizontal* velocity of a soaring plane, set at an angle, diminishes with increased speed.

5. That aëroplanes set one above another exert no unfavourable effect on each other if they are separated

* By back-flow ("slip") is meant the difference between the actual velocity of advance and the velocity that would be secured if the propeller were working in immovable air, like a common screw in a solid nut.

by a distance at least equal to the length of the edge that is parallel to the line of travel.

This condition is practically the most noteworthy, because it indicates that we may avoid the difficulties attending the use of very large aëroplanes.

Finally, the possibility is demonstrated of causing inclined aëroplanes to soar at a velocity of about twenty metres per second (about forty-four miles per hour), with a load of about ninety kilogrammes (about one hundred and ninety-seven pounds) per horse power. At the same time it is to be noted that we have steam motors weighing less than ten pounds per horse power, and that the weight that aëroplanes will have to carry is not more than ten per cent of what the investigations in question have shown. We may therefore assume that the above rules will be applicable to planes of larger dimensions, though we cannot yet assert that objects are to be carried soaring in the air in the best way by the use of aëroplanes.

It was stated on page 129 that further consideration would be given to the assumption that we are within the limits of exactness when we assume the average pressure on the whole plane to be the same as the pressure at the centre. This was correct in that instance, but is not to be taken as a general rule. With reference to this, we learn from the observations of Lauriol* that the pressure on each unit of the aëro-

* *Revue de l'Aéronaute*, fourth year.

plane is indeed proportionate to the square of the velocity of movement, but is not dependent on the velocity of movement of neighbouring points. Also with the self-registering apparatus for the resultant and component forces, we must consider not only the forces exerted on the plane, but also its momentum with reference to the centre of the lever. This indicates the points which are moved at the greatest speed, also at the greatest distance from the lever, so that the pressure and the distance, or the two factors of the moment, decrease simultaneously. The deviations that can result from this are, however, in the apparatus discussed, still within the limit of exactness.

The circular movement of the apparatus has also the inevitable result of carrying the air with it, especially by the points which, like the aëroplane under trial, stand perpendicular to the line of advance. A body carried in a circular movement at the end of an arm $r = 9$ M or thirty feet long, at a speed of 20 M or sixty-seven feet per second, is thereby subjected to the effect of a centrifugal force, which, per unit of the mass, amounts to: $\frac{V^2}{r} = \frac{400}{9} = 44$, or about 4.5 times, the gravity being assumed at 9.8.

The air will not, however, be exposed to such a great centrifugal force, for it will tend to move in the direction of the radii towards the outer side, which will have the result:

That the relation between the velocity of the air

and of the plane will be modified in quantity and in direction. The renewing of the air will thus, by the contact with the aëroplane, no longer appear under the same conditions; and as the pressure on the aëroplanes, according to Langley, will be controlled by the greater or less renewal of the air, it is to be feared that the value of the pressure may be modified by the addition of the component centrifugal force.

If, on the other hand, the component centrifugal force be disregarded, then the displacement of the centre of pressure in the planes under trial was not correctly indicated, and before determining the power the self-registering moments of the arm of the lever should have been carefully studied. Here the question comes up as to whether or not these forces may be entirely disregarded, as they cannot yet be determined. This calls still for an exact comparison with the results that may be reached by velocities in rectilinear movement, and this, for a speed of twenty metres per second (forty-four miles per hour), is only possible by observations to be taken on a railway car, which would even then call for the most careful consideration, and which could probably be carried out under favourable conditions on the Netherlands Railway.

Lauriol also considers Langley optimistic in his views when he decides that one horse power is sufficient for moving a weight of more than ninety kilogrammes (one hundred and ninety-seven pounds) at a velocity of twenty metres per second. Very possibly there may

be more or less justice in this, but an increase of the power of machinery need create no preponderating difficulty, and concerning this further investigations are necessary to a final conclusion. The importance of direct observations at high velocities and on a straight course is, in my opinion, imperative.

Finally, Drzwiecki, who has already been mentioned in my first publication, compares the results of his earlier theoretical observations and computations with the practical investigations of Prof. Langley.*

	V.	a°.	P.	R.
Langley, experimentally . .	20 m.	2°	5.38 kilos.	20 grms.
Drzwiecki, by computation	20 m.	1° 50' 45"	5.17 "	21.7 "

[The author, referring to the prize papers published in the *Cosmopolitan Magazine*, by Hiram S. Maxim and John P. Holland, says :]—*Translator*.

Mr. Maxim is, according to Prof Langley, recognized as one who has already distinguished himself by the practical application of his ideas. The apparatus projected by him is now probably complete. It is made on the principle of the aëroplane, with a width of about one hundred feet measured between the extremities of the wings, forming practically stiff, kite-shaped supporting planes. The machine is provided with two equal screw propellers, comparable with those of the great transatlantic steamers, operated by steam engines of

* *Revue de l'Aéronaute*, fourth year.

about the same nominal horse power as those of the earliest steamers. This power is, according to Langley, probably sufficient for maintaining the horizontal soaring movement of the machine, if only it can be moved in the right direction.

Especially must the machine be put together in the stoutest manner and constructed with the greatest mechanical skill. In view of Mr. Maxim's great energy and determination and of his knowledge, we may trust that he will be able to make head against the remaining mechanical difficulties of aërial navigation. This will now be the hearty wish of all; yet it cannot be concealed that he is sure to meet with great difficulties in connection with the steering of his apparatus; and these must be overcome during its free flight in the air.

On the other hand, it is not to be denied that in the high velocity of movement that must be attained there exists a guarantee that success will be reached in this also, as may be observed in the case of the movements of bird flight. We can therefore await with confidence the final success of aërial navigation. Nevertheless, he who shall first trust himself to such a means of transportation, and take the risk of flying through the element that lies above us at an amazing speed, must display a dauntless heart and great presence of mind. If he succeeds, however, which in the end cannot be questioned, then there can be no limit to the renown he will reap.

It must, however, be borne in mind that it is not enough to secure the means for sailing through the air; we must also learn to make use of these means. In this aspect a comparison may be made with swimming, skating, and riding the bicycle, for which we have the means and the strength, but for which we have to learn the

method of application. Probably here, as with everything else, it will be the first step that costs, and it is to be expected that the first navigation of the air will be attended with risk of life. Still, this should be no insurmountable obstacle, for the first balloon ascensions were not without danger, and they were made nevertheless. What yet remains to be assured before aërial navigation can become practicable, as was the case in ordinary navigation, is the ability to steer the apparatus, and concerning this we are not as yet in a position to form any definite conclusion.

As supplementing the author's remarks, it will be of interest to refer to the admirable article in the *Cosmopolitan Magazine* for June, 1892, for which Mr. Maxim received the first prize offered by that magazine. It is here suggested that the trial machine be constructed in a large building, for protection against wind, and that a circular railroad be provided, one mile in circumference, the machine being mounted on wheels. The conclusion of the paper is as follows :

“ We should first ascertain how much power was required to propel its bare poles or tubes through the air at various velocities. The machine should be run around the one-mile track at all speeds from twenty miles per hour to one hundred miles per hour, and the power actually required should be carefully noted. These runs would enable us to ascertain how our pumps worked at high speed, and how much our screws pushed, and if we put a brake to the wheels we should find out the slip of the screws. We could also ascertain the efficiency of our condenser at various speeds, and the tem-

perature of the water could be taken. In order to run on a railway track, the machine, of course, must be provided with wheels, and two sets of these would be necessary; one set should be of great weight, so as to hold the machine down when running on the track, and the other set should be very light, for actual flying. Springs should be interposed between the axletrees and the machine, after the manner of railway carriages, and there should be attached above each wheel some sort of an index or indicator to show the exact load resting on each wheel. When all the parts of the machine had been made to operate smoothly and satisfactorily, the silk could be placed on the *aéroplanes*, and then our serious experiments might be said to commence. We should first begin by running slowly—say at the rate of twenty miles per hour—and carefully note the lift on the indexes over each wheel. If we found that with a speed of twenty miles an hour three fourths of the load was lifted off the forward axletree and only one fourth off the hind one, then we should change the centre of weight farther forward so as to bring it as near as possible under the centre of effort or lift. We should then make another trial, and if we found that the lift was equal both fore and aft, we should increase the speed very carefully—gradually observing the lift at the four corners of the machine—until the whole weight of the machine was supported by the *aéroplane*, and the whole weight of the wheels—about one ton—by the railway track. Then, when there was neither lift nor load on either wheel, we might consider that we had arrived at a stage in our experiments where we could turn our attention to the subject of steering.

“A boat has to be steered in only one direction—namely, a horizontal direction—to the right or to the

left. A locomotive torpedo or a flying machine must be steered in two directions, right or left and up or down. We should experiment with the more difficult one at first, namely, the up-and-down or vertical direction. We should attach two long arms to our aëroplane in such a manner that they would project a considerable distance in the rear of the machine. To these arms we should pivot a very large and light silk-covered rudder and connect it with ropes so that it could be turned up or down by a small windlass from the machine. We should then take a run on the track and see if changing the angle of this rudder would increase or diminish the load on the forward or hind wheels. If we found that it would do this, but not sufficiently so, we should attach another rudder in exactly the same manner to the forward end of the machine. Suppose that at a speed of thirty-five miles per hour, with both rudders set at the same angle as the aëroplane, we should find that the whole weight of the machine was carried by the aëroplane, and the whole weight of the wheels (two thousand pounds) by the track; we could then consider that the adjustment of our load was correct, and that the centre of weight was directly under the centre of effort for a speed of thirty-five miles an hour. We should then elevate the front edge of the forward rudder and depress the front edge of the rear rudder; this would cause the machine to lift on the forward axletree and the rear end of the machine to press on the hind axletree. If we found by changing the angle of the rudders that the load could be increased or diminished on either axletree to the extent of fifteen per cent of our whole load, we could consider that this phase of the problem was solved.

“For horizontal steering, we should try first the effect of the screws. There should be a three-way valve in the

steam pipe connected with a lever, so that we should be able to partly close off the steam from the engine of one screw and turn more steam on to the other. This would probably be all that would be found necessary; if not, we should try rudders.

“To prevent the machine from swaying in the air, the *aëroplane* should be so constructed that no matter in which direction it tilted it would diminish the lifting power of the lifted part and increase the lifting power of the depressed part. This would be simple and automatic; moreover, the stability of the machine could be still further increased by having the centre of gravity much below the centre of lift. Having all things in readiness, the heavy wheels should be removed and the light ones put on, and taking one man with us to attend to the two horizontal rudders and to keep the machine on an even keel, we should take our first fly, running the engines and doing the right and left steering ourselves. A day should be selected when there was a fresh breeze of about ten miles per hour. We should first travel slowly around the circular railway until we came near that part of the track in which we should face the wind. The speed should then be increased until it attained a velocity of thirty-eight to forty miles an hour. This would lift the machine off the track, and probably would slightly change the centre of effort. This, however, would be quickly corrected by the man at the wheel. While the machine was still in the air careful experiments should be tried in regard to the action of the rudders; it should be ascertained to what degree they had to be tilted in order to produce the desired effect on the machine. The machine should also be run at a speed less than thirty-five miles per hour in order to allow it to approach the earth gradually; then the

speed should be increased again to more than thirty-five miles an hour in order to rise, at the same time trying the effect of running one propeller faster than the other to ascertain to what extent this would have to be done in order to cause the machine to turn to the right or to the left. If the machine should be constructed so that each particular foot of its surface carried a load of one pound two ounces, and if we should stop the engine dead and allow the machine to fall, it would approach the earth at a speed of fifteen miles an hour, or one mile in four minutes. This evidently would cause a considerable shock, and unless there was a good deal of elasticity to the parts and a good deal of travel between the axletrees and the machine, the shock would probably be sufficient to distort or injure some part of the light structure. But it is not necessary to approach the earth directly. Prof. Langley found in his experiments that when a horizontal plane was travelling rapidly through the air it approached the earth as though it were 'settling through jelly.'

"A large field as near our railway as possible should be selected for alighting, and having approached the field so as to be facing the wind, we should gradually descend by slowing up the engines, and finally alight while the machine was still advancing at the rate of twenty miles an hour. If the wind should be blowing at the rate of ten miles an hour the machine would approach the earth very gradually indeed, so that all shock would be avoided. It would only require a few yards of comparatively smooth ground to run on after alighting in order that there should be no disagreeable shock or danger. The cost of these experiments would be from fifty thousand to one hundred thousand dollars, and the time required would be two years."

The author continues :

Mr. John P. Holland, to whom was awarded the second prize offered by the *Cosmopolitan*, agrees with Maxim that the navigation of the air appears to be possible only with the use of the *aéroplane*, and that nothing is required for it that is not already known and proved. There is wanting only a suitable apparatus, combining what is now in daily use, and satisfying the following requirements :

1. The machine must be able to lift and support itself in the air.

2. It must be capable of rising and alighting vertically, and slowly or rapidly at will, in storm or calm.

3. It must be incapable of tipping over or upsetting.

4. It must be capable of rapid horizontal motion, and of easy and steady steering in any direction.

5. The complete machine and each of its parts must be so strong that there would be required to destroy it a strain or stress six to ten times greater than any to which it is ever likely to be subjected.

The motor must, therefore, be strong and light. It must be ample to lift its own weight and that of the machine with its ballast, and to move it steadily through the air. Mr. Holland is of the opinion that these requirements can be fully met by the use of the screw propeller and the *aéroplane*.

Agreeing with his opinion, I found it the more

entitled to acceptance because he has already distinguished himself as a constructor by the building of a submarine boat or torpedo, and he chooses this as the example best to be followed in navigating the air. This did not surprise me, for I had already (Chapter III) pointed out the similarity of air balloons with sea and river buoys; but the comparison of the torpedo with devices for traversing the air seems to me much closer. Both must always move with great speed through the surrounding fluid, the first through the water and the second through the air, and each must find support in its medium in order to maintain its stability and to travel. Both also have a tendency to sink or fall in the fluid, which, however, must not be permitted, so that they must not exceed a certain weight relatively to the resistance of the medium in which they are immersed. There thus exists, as to the motive power and the required lightness, an undoubted similarity in the conditions that must serve for the torpedo and for the air machine, and this justifies Mr. Holland's preference.

We can also point to a considerable number of powerful and at the same time light motors, used in connection with torpedo boats, which, including boiler and fuel, weigh only sixty pounds per horse power. In this matter attention may also be called to the following:

Mr. Norman L. Munro's yacht *Norwood* had boilers and engines weighing only nineteen pounds per horse power.

Mr. H. S. Maxim has built and operated a boiler and engines that weigh together only nine pounds per horse power.

Mr. Stringfellow, of London, built a complete steam motor, nearly a quarter of a century ago, that weighed only thirteen pounds per horse power. Prof. Langley is authority for the statement that effective steam engines have lately been built weighing less than ten pounds per horse power.

It is further to be said that—

Freninges, of Copenhagen, obtained by the lift of his wheel the effect of sixty-three per cent of the power applied.

Langley, in his observations, obtained a lifting effect of two hundred and forty pounds per horse power. Maxim obtained similar results.

These machines are all light enough, and even the heaviest—that of the torpedo, weighing sixty pounds per horse power—has a not inconsiderable margin, for, with a useful effect of sixty-three per cent and a weight of sixty pounds, about $\frac{60 \times 100}{63} = 95$ pounds per horse power will be delivered. Making the usual deduction for loss and friction, we get a weight of less than one half of what one horse power can lift.

Meanwhile Mr. Holland considers fourteen pounds per horse power enough for the weight of the rest of the machine, giving a total weight of $95 + 14 = 109$ pounds per horse power, leaving a margin of $240 - 109$

= 131 pounds per horse power before reaching the limit of the lifting force.

He then considers whether or not the Norwood boilers and engines will meet the conditions set up. He supposes a pair of propeller wheels of suitable dimensions to be placed in a framework concentrically or on concentric shafts with the Norwood boiler and engine, as shown in the figure. Care must be taken so to place the machinery that its centre of gravity falls in or under the propeller shafts.

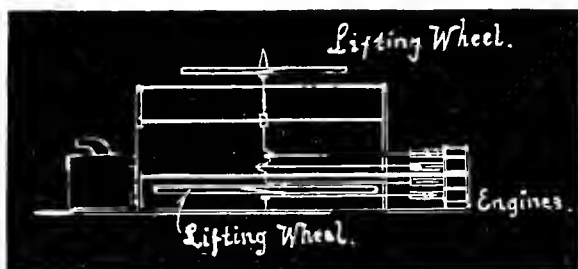

FIG. 14.—Scale, one-sixteenth inch=1 foot.

The apparatus will rise when the upward thrust caused by the revolution of the propellers is greater than the weight of the machine. The maximum speed of ascent will depend on the amount of reserve lifting power. This, and the speed of descent, may be regulated by the throttle-valve.

The machine answers in this condition for higher requirements than a balloon, because it completely satisfies conditions 1, 2, and 3, and, besides, a motor can be

made light and strong enough to meet the requirements of the 5th condition. There remains, then, only the 4th condition of rapid horizontal propulsion, which, as Holland shows, may be attained without providing any special power for the purpose. For this, aëroplanes are employed, and modifying the design, as shown in Figs. 15, 16 and 17, to permit of inclining the axes of the screws to a horizontal position, the power may be applied directly to lifting at first, and, when a suitable elevation has been attained, the axes of the screws, with the engines and framework, may be revolved about their common centre of gravity through ninety degrees, so that the axes or the common axis is placed horizontally.

While the machine is rising vertically, the power exerted by the screws serves both to support its weight and for the upward movement. When the axis is inclined, by the revolving of the framework, the power is in part transferred to the production of a horizontal movement, and in part to the support of the machine, in connection with the soaring of the aëroplanes. The operation is reversed in descending. We have then only to regulate the inclination of the axis, according to the direction and force of the wind, to make vertical descent possible even during a storm.

Thus the 2d, and the first part of the 4th condition, will be satisfied, while for the second part of the 4th there will be needed only vertical and horizontal rudders, after the manner of submarine boats and White-head torpedoes.

The superficial extent of aëroplanes is fixed by Chanute's table, which gives more than is needed, as it is based on experiments with flat planes of considerable thickness and with rectangular edges. We should, therefore, get better results with modified forms and sharpened edges. This is indicated by the important experiments of Horatio Phillips, of London, in 1885, where ordinary planes were compared with a thin plane with sharp edges, concave on the under and convex on the upper side. These experiments were confined to angles of fifteen degrees with the horizon, yet their results were remarkable. They should be more decisively repeated with Prof. Langley's apparatus.

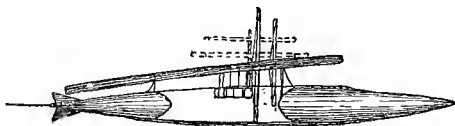

FIG. 15.—ELEVATION.

At an angle of fifteen degrees with the horizon, a thin flat plane had a power for lifting, according to Phillips, of 4·5 and, according to Chanute, of 3·714 times that of horizontal movement. The effect of the thickness of the edges in Chanute's tables is, however, uncertain, but, to judge from the correspondence of his results with those of Langley, there must have been a great similarity between the planes used in the experiments.

The results obtained by Phillips were sixteen per

cent more favorable than Chanute's, which probably resulted from the finer edges of the planes, and by the form. The results ought, however, to have been still more favorable, if the planes had been concave in the line of the direction of the wind and convex at the back, with stream lines at the edges. A plane of this sort, moderately concaved, but quite thick toward the leading edge, gave a force in lifting of 10·34 times that of the horizontal movement. This result seems, therefore, to be 2·75 times better than that of the angular plane and 2·3 times better than by Phillips's experiments. If these last are trustworthy, we need use only three hundred and sixty-five square feet of aëroplane where Chanute's table indicates one thousand square feet. The smaller dimensions are shown in the sketch, Fig. 17.

It is, however, quite possible that the superiority of the smaller planes tried by Phillips will appear less with smaller angles of elevation, though Holland suggests that it will continue for the smallest angles practical with aëroplanes. It appears also that the shapes of their sections modify the stream lines, reducing the horizontal resistance without changing the lift. This makes a greater angle of inclination possible, and obviates the liability to vibration that Maxim observed with very small angles, giving the power of a large surface at slight inclination, without its disadvantages.

Remembering that observation has shown the surface of the aëroplane, for a certain weight, to be in-

versely as the square of the velocity, and that the lifting power and the horizontal force increased directly as the square of the velocity, it is further possible that we may attain great speed with a very compact machine; but this opinion can lead to no practical results until it is established by more extended suitable experiment.

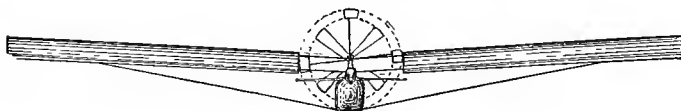

FIG. 16.—END VIEW.

Chanute's table shows also that for a good weight and great speed a small angle of inclination will suffice. One square foot of aëroplane, at an inclination of four degrees with the horizon, will, with a velocity of eighty miles per hour, give 4.448 pounds lift and a horizontal resistance of 0.3104 pound; so this aëroplane must be moved 7,040 feet per minute against a resistance of 0.3104 pound, amounting to 2,185.216 foot-pounds per minute, which is equal to 0.0662 horse power per square foot of aëroplane. Using the Norwood engines, with four hundred indicated horse power, we get a useful effect of sixty-five per cent—less than with some torpedo boats—and we have $400 \times .65 = 260$ horse power available, and for the surface of the aëroplane, according to Chanute, $\frac{260}{.0662} = 3,928$ square feet of aëroplane surface; $3,928 \times 4.448 = 17,471$ total lifting power.

Holland further estimates the weight of the com-

plete machine, including engines, with all appliances and operators, as twenty-nine pounds per indicated horse power.

Total weight (400 horse power \times 29 pounds) 11,600 pounds.

Total lifting power..... 17,471 “

Reserve lifting power..... 5,871 “

The correct adjustment of length to breadth of the calculated *aéroplane* is very important. That this is by no means a matter of indifference appears in a general way:

1. From the observations of Froude, with regard to frictional resistance of flowing water, which, with planes of equal area, increased with the increase of the width across the stream and with the decrease of length in the direction of the stream; and—

2. From the observations of Prof. Langley, who deduced the same results for resistance in the air.

We are, however, wandering in complete uncertainty as to the value to be ascribed to the different measurements, if we consider a large continuous surface, especially if it is capable of concaving, with an increase of efficiency, as is indicated by sailing vessels. We can thus make no calculation as to whether this advantage equals or overbalances that of the narrow planes or not. A single great plane will be simpler and lighter than a great number of small planes. On the other hand, from the point of view of safety, this would seem to offer less liability to accident, as will be seen by a comparison of Figs. 15, 16, 18, and 19.

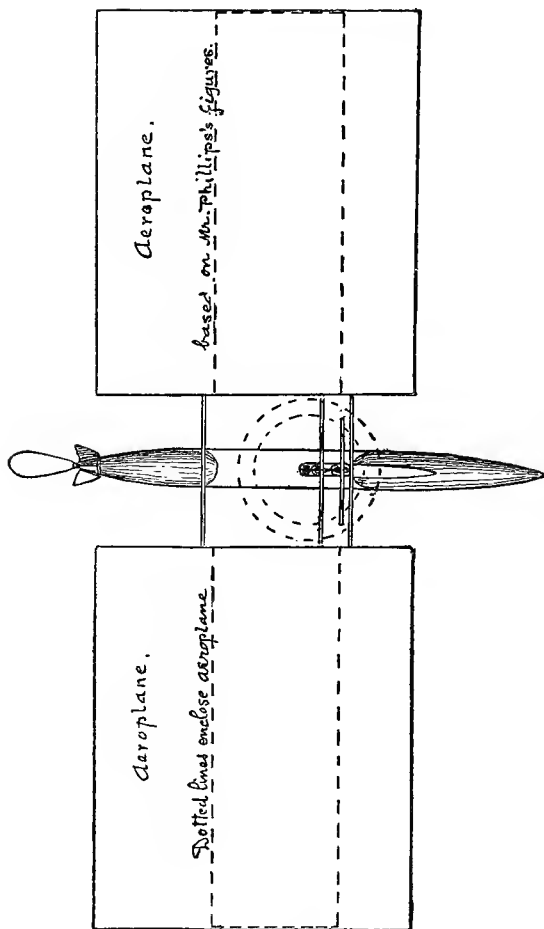

FIG. 17.—PLAN.

According to Chanute, the flying machine has to encounter three elements of resistance—due to the weight of the apparatus, to the velocity of movement, and to the friction on the surface (skin friction).

According, however, to the observations of Langley and Phillips, the loss of power by the skin friction and by the slip is included in the propelling power, so that, speaking in general terms, we need take account only of the velocity.

Mr. Holland has deduced his pair of screw propellers from the observations of Dr. Freninges. They must be able, with four hundred revolutions per second, to lift together a weight of 17,471 pounds. Their diameters are fixed at 16·89 feet and 14·16 feet, which at the same speed will give them equal power, and, of this, sixty-three per cent is assumed to be available.

The axes of the propellers in rising are placed exactly over and eight feet above the centre of gravity. For horizontal movement they are in the plane of the centre of resistance and five feet above the centre of gravity.

The weight of the motor and gearing is fixed as per the statements given :

Weight of Motor and Gear.

Boiler, complete, with water	4,000	pounds.
Engines, propellers, and frame . . .	2,000	“
	<hr/>	
Total weight of motor	6,000	“

Weight of motor and gear per indicated horse power,
 $6,000 \div 400 = 15$ pounds per horse power.

Weight of body, aëroplanes, connections, and operators :

Aëroplane frame.....	1,800	pounds.
Body	900	“
Cover for both	1,176	“
Trussing, stays, and braces.....	200	“
Three men	450	“
	4,526	“

Weight of machine and operators per indicated horse power,

$$4,526 \div 400 = 11.31 \text{ pounds.}$$

Weight of machine and motor, complete, with operators, per indicated horse power,

$$10,526 \div 400 = 26.31 \text{ pounds per horse power.}$$

Carrying Power.

Total lifting power at 80-miles speed... 17,471 pounds.

Total weight, complete, but unloaded... 10,526 “

Carrying power

6,945	“ *
-------	-----

As to the accidents and difficulties which may be encountered, Holland says that, in view of the rapidity of horizontal movement, a comparison with railroad travel is suggested. In this comparison aërial navigation is distinguished from railroad travel by an extraordinary smoothness of movement and the absence of many

* *Cosmopolitan Magazine* for November, 1892, p. 94.

difficulties with which railroad men have to contend, such as irregularities in the roadbed due to the slightest settlement, the joints of the rails, curves, vibration of the track, drawbridges, etc. Then, too, no care need be given to the correct position of signals, and there is nothing to be feared from obstructions by snow, freight trains, etc.

As to the possibility that the machine may not always maintain its position in the air, this cannot be altogether denied, even with the greatest care devoted to the planning and execution of the apparatus. Should, however, such trouble unexpectedly arise in the air, the vehicle still cannot suddenly come to a standstill and fall at once. It will, on the contrary, continue until its momentum is exhausted, and the descent can without difficulty be so controlled as to alight on a smooth place, with little speed and without shock or injury. This seems to be the opinion of Mr. Maxim, as well as of Mr. Holland. Even when alighting in the water there would not be a particle of immediate danger, for no shock would be felt, and the machine would float like an ordinary boat. If the injury is slight and can be quickly repaired, the machine can rise from the water and continue its flight.

The framework and the propellers can be made strong enough for all contingencies.

If we examine the relative positions of the point upon which the propelling power acts, and of the centres of resistance, of support and of gravity, during hori-

zontal movement and during ascent and descent, we must see that the machine cannot capsize, for the laws of Nature will prevent it.

Such difficulties as may be apprehended have indeed all been met and overcome in submerged vessels and

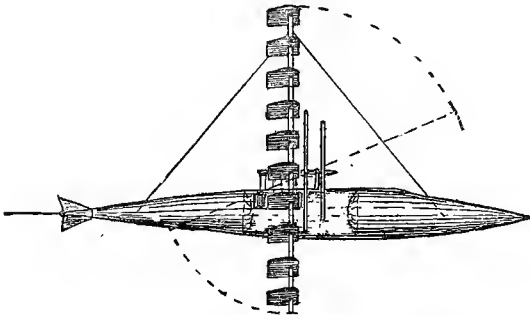

FIG. 18.—DESIGN WITH SUPERPOSED AËROPLANE.
Scale one-sixteenth inch = 1 foot.

torpedoes. They are evidently the same in this case, and they can be prevented by the same means, including the use of rudders of small size.

Finally, taking the estimates made as a basis, we must calculate on a considerable addition to our reserve force, to provide against unforeseen conditions and to enable us to make subsequent improvements.

A thoughtful consideration of the projects and ideas of Mr. Holland cannot fail to lead to the conviction that the possibility of navigating the air is no longer to be disputed on theoretical grounds. On the practical side we have still to consider—

1. In how far the velocities and the phenomena at-

tending circular movement will correspond with those of rectilinear movement.

2. Whether or not an apparatus constructed of aluminum, for the sake of lightness, will be in all respects strong enough. Possibly experience with the torpedo boats has given some indications as to this.

3. What is the best form for aëroplanes, and what is the minimum speed required at low angles of inclination, in order to carry a given weight of apparatus and load with the necessary stability in the air?

4. How steering at high velocities is to be insured. This may not be easy to do, and the difficulty may turn out to be only a temporary one.

5. What would be the influence of barometric conditions and the greater or less rarity of the air on its resisting power for the propulsion of the machine? The table on page 29, and the observations made in Chapter III, should be consulted for an assurance as to this influence.

It cannot be doubted that a scientific shipbuilder, possessing the required theoretical knowledge, will be able, following these principles, to plan an apparatus for navigating the air and to construct it and put it in operation. Such a machine could, perhaps, lay no claim to the best solution of the question, nor to correct proportion of its details, but that was also the case in the past with ordinary navigation. It is more to be expected here, because the investigations required for aërial navigation are not yet completed,

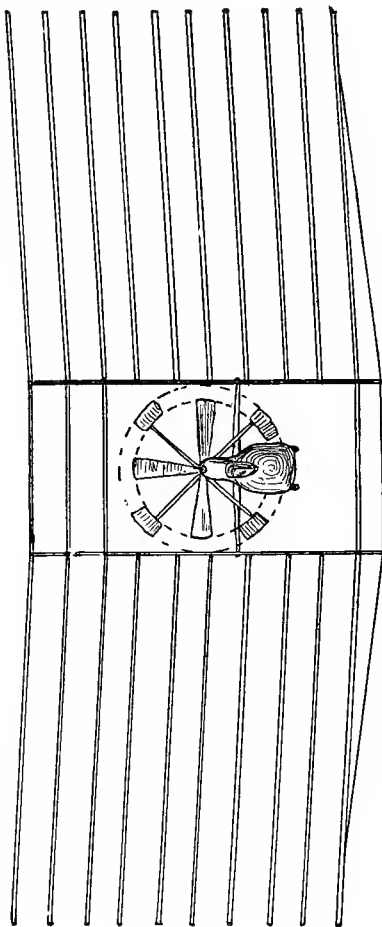

FIG. 19.—END ELEVATION.

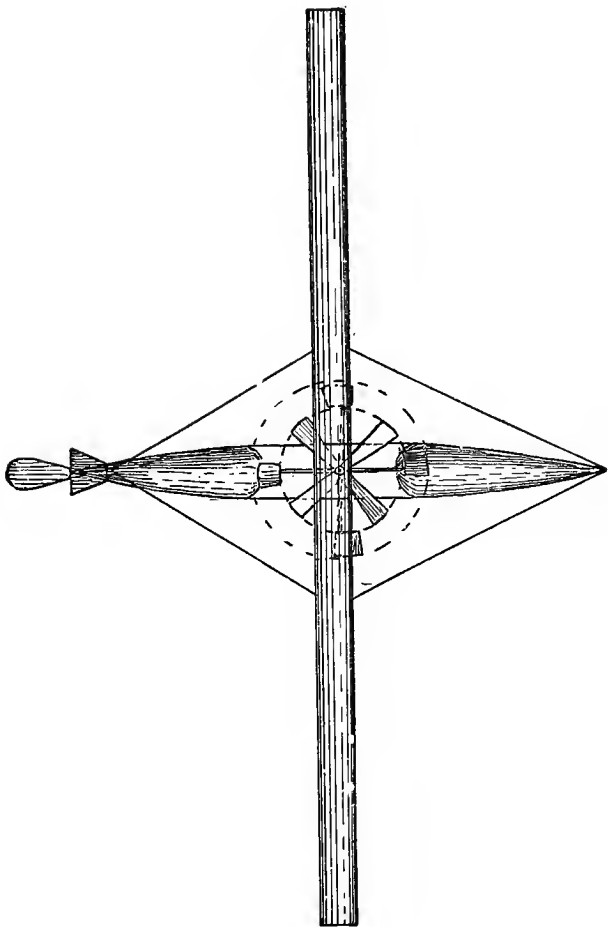

Fig. 20.—PLAN.

as is plain from the preceding considerations of the subject.

Knowledge is power, and it is most desirable that the whole subject be earnestly studied, so that the gaps still remaining may be filled. The development of aërial navigation was checked for nearly a century by the lack of knowledge to be gained only by thorough investigation. Scientific investigation really began only in the second half of this century, and it seems to me that in this field the installation at Chalons and the experiments of Prof. Langley are distinguished above all else. Some delay is to be expected. The necessary observations must require much time—in my opinion three years, if not longer—and the World's Fair at Chicago will not see them completed. It will, on the other hand, stimulate public interest to see aërial navigation practically exhibited there, even though not completely successful, as is, of course, to be expected.

This wonderful nineteenth century may yet show, as its final great achievement, a thus far unexpected perfection of the balloon, and, what will be still more important, a successful application of Nadar's principle, "*Le plus lourd que l'air.*"

This may exert a powerful influence on social conditions, of which we can now form no adequate idea.

ARCACHON, *February, 1893.*

PROF. LANGLEY'S EXPERIMENTS.*

No account of what has been done in connection with the navigation of the air would be complete, if even fully comprehensible, without further reference to the remarkable experiments in the field of aërodynamics devised and carried out by Prof. Langley. These are fully set forth in Volume XXVII of the *Smithsonian Contributions to Knowledge*. It will be useful to reproduce here some of the less detailed portions of Prof. Langley's report. He says :

“To prevent misapprehension, let me state at the outset that I do not undertake to explain any art of mechanical flight, but to demonstrate experimentally certain propositions in aërodynamics which prove that such flight under proper direction is practicable. This being understood, I may state that these researches have led to the result that mechanical sustentation of heavy bodies in the air, combined with very great speeds, is not only possible, but within the reach of mechanical means we actually possess; and that while these researches are, as I have said, not meant to demonstrate the art of guiding such heavy bodies in flight, they do

* *Experiments in Aërodynamics*, by S. P. Langley, Smithsonian Institution, Washington, 1891.

show that we now have the power to sustain and propel them.

“Further than this, these new experiments (and theory also, when reviewed in their light) show that if in such aërial motion there be given a plane of fixed size and weight, inclined at such an angle, and moved forward at such a speed that it shall be sustained in horizontal flight, then the more rapid the motion is the *less* will be the power required to support and advance it. This statement may, I am aware, present an appearance so paradoxical that the reader may ask himself if he has rightly understood it. To make the meaning quite indubitable, let me repeat it in another form, and say that these experiments show that a definite amount of power so expended at any constant rate, will attain more economical results at high speeds than at low speed—e. g., one horse power thus employed will transport a larger weight at twenty miles an hour than at ten, a still larger at forty miles than at twenty, and soon, with an increasing economy of power with each higher speed, up to some remote limit not yet attained in experiment, but probably represented by higher speeds than have as yet been reached in any other mode of transport—a statement which demands and will receive the amplest confirmation later in these pages.

“In this untrodden field of research, which looks to mechanical flight not by means of balloons but by bodies specifically heavier than the air in which they move, I think it safe to say that we are still, at the time this is written, in a relatively less advanced condition than the study of steam was before the time of Newcomen; and if we remember that such statements as have been commonly made with reference to this, till lately

are, with rare exceptions, the product of conjecture rather than of study and experiment, we may better see that there is here as yet no rule to distinguish the probably important from the probably unimportant, such as we command in publications devoted to the progress of already established sciences.

“ I do not, then, offer here a treatise on aërodynamics, but an experimental demonstration that we already possess in the steam engine as now constructed, or in other heat engines, more than the requisite power to urge a system of rigid planes through the air at a great velocity, making them not only self-sustaining, but capable of carrying other than their own weight. This is not asserting that they can be steadily and securely *guided* through the air, or safely brought to the ground without shock, or even that the plane itself is the best form of surface for support; all these are practical considerations of quite another order, belonging to the yet inchoate art of constructing suitable mechanisms for guiding heavy bodies through the air on the principles indicated, and which art (to refer to it by some title distinct from any associated with ballooning) I will provisionally call *aërodromics*.* With respect to this inchoate art, I desire to be understood as not here offering any direct evidence, or expressing any opinion other than may be implied in the very description of these experiments themselves.”

There was used in these experiments what was called a “whirling-table”—a revolving arm, sixty feet long,

* From *ἀεροδρομέω*, to traverse the air; *ἀεροδρόμος*, an air-runner.

driven by a central axis, geared to a ten-horse-power engine. The plane of revolution was about eight feet above the ground. The highest speed attainable for the end of the arm was about seventy miles per hour. The precise velocity was determined by an electrical self-registering apparatus.

The aëroplanes used in the experiments were mounted at the end of one of the arms in such a way as to reduce resistances due to centrifugal force and to friction to a minimum, and these resistances were carefully measured by suitable appliances. Other devices were used for recording the resultant pressure, the component pressure, the velocity of fall of the plane at rest and in motion, and the time-power consumed.

“Perhaps the most important primary fact exhibited by these experiments is that the time of fall for horizontal planes of all shapes is greater as the horizontal velocity increases, and also (as the form of the curves shows) that this retardation in the velocity of falling goes on at an increasing rate with increasing velocities of translation.

“Secondly, we see that those planes whose width from front to back is small in comparison with the length of the advancing edge have a greater time of fall than others. This difference is uniform and progressive from the 6×12 inch planes to the 18×4 inch planes. Expressing this advantage quantitatively, the curves show that the planes having an advancing edge of six inches and a width of twelve inches from front to back, when they have a horizontal velocity of twenty metres per second, fall the distance of four feet

in 0·7 second, while planes of the same area and weight having the advancing edge eighteen inches and four inches from front to back, when moving with the same velocity, are upheld to such an extent that their time of fall is two seconds. This interesting comparative result is also indirectly valuable in giving additional evidence that the largely increased time of fall of the better-shaped planes at the high speeds is not due to the lateral friction of the falling piece against the frame. The friction with the 6×12 inch planes is as great as with any of the others, yet their time of falling is only slightly greater at high speeds than at rest. Attention is called to the fact that at the highest velocity attained in the present series of experiments—twenty metres per second—the curve shows that the time of falling of the 18×4 inch planes was increasing very rapidly—so much so as to make it a subject of regret that the slipping of belts prevented experiments at still higher speeds. We may, however, reasonably infer that, with a sufficient horizontal velocity, the time of fall may be prolonged to any assigned extent, and that for an infinite velocity of translation the time of fall will be infinite, or, in other words, that the air will act as a solid support.

“It may be of interest to connect these observations with some partly analogous facts which are more familiar.

“It is frequently observed that a sheet of very thin ice will bear up a skater, if he is in rapid motion, which would not sustain his weight if he were still; and even if we neglect the slight difference of specific gravity between water and ice, and suppose the latter to have no differential buoyancy, the rapid skater will still be able to pass safely over ice that would not bear his weight if

he were at rest; for while his mass is the same in both cases, that of the ice called into play in sustaining him is only that corresponding to one unit of area when he is at rest, but to many when he is moving.

“In this form of explanation and illustration the attention is directed only to the action of the air *beneath* the plane, but, in fact, the behaviour of the air *above* the plane is of perhaps equal importance, and its action has been present to my mind throughout these experiments, although for the purpose of concise exposition only the former is here referred to. By analogous reasoning in the case of a heavy body immersed in any continuous fluid, even gaseous, while the mass of air or gas whose inertia is called into action is small and affords a slight sustaining power when the body is at rest, it becomes greatly multiplied by lateral motion, and the more rapid this lateral motion the greater will be the sustaining action of the fluid. So, then, in the case of any heavy body which will fall rapidly in the air if it fall from rest, the velocity of fall will be more and more slow if the body be given successively increasing velocities of lateral translation and caused to run (so to speak) upon fresh masses of air, resting but a moment upon each.

“The above analogy, in spite of its inefficiency as regards the effect of elasticity, is useful, and may be further extended to illustrate the relative results obtained with the differently shaped planes and with the same plane under different “aspects”; thus the action on the air of a plane whose advancing edge is twice its lateral edge—e. g., the 12 × 6 inch plane, with twelve-inch side foremost—may be compared to that of two skaters side by side, each advancing over his own lines of undisturbed ice; but the same plane with the six-inch side foremost, to the same skaters, when one is behind the

other, so that the second is passing over ice which has already yielded to the first and is partly sinking.

“The second series of experiments, made on the same dates as the first, was to cover the third object of experiment—that is, to determine for different angles of inclination what speed is necessary in order to derive an upward thrust just sufficient for sustaining the planes.

“The results of these two series of experiments furnish all that is needed to completely elucidate the proposition that I first illustrated by the suspended plane, namely, that the effort required to support a bird or flying machine in the air is greatest when it is at rest relatively to the air, and diminishes with the horizontal speed which it attains, and to demonstrate and illustrate the truth of the important statement that in actual horizontal flight it costs absolutely less power to maintain a high velocity than a low one. It has already been explained that when the planes have such an angle of elevation and such a horizontal velocity that they first rise from their support, and are then with a slightly diminished velocity just sustained without falling, they are said to ‘soar,’ and the corresponding horizontal velocity is called ‘soaring speed.’”

The planes experimented with, described in the previous pages, were set in pairs, and in one set of experiments observations were taken of the effect of placing one above the other at different distances of separation.

“The results of these observations with two sets of planes, one above the other, give us a first conception of the form and initial vertical amplitude of the wave

that is set in motion in the air by a plane passing horizontally through it in the manner of these planes.

“These later observations also furnish incidentally additional data as to the velocity of soaring. When inclined at an angle of ten degrees, the single planes and the double planes, at a distance of four inches apart and upward, are sustained in the air if they have a horizontal velocity of about 13·2 metres per second. When set at one degree, soaring took place at velocities from twenty-one to twenty-three metres per second. Close observation also indicated that the error of verticality of the plane-dropper during motion did not exceed one degree; hence, for these velocities the soaring angle may be taken at about two degrees. . . .

“The most general and perhaps the most important conclusion to be drawn from them appears to be that the air is sensibly disturbed under the advancing plane for only a very slight depth; so that for the planes four inches apart, at the average speeds, the stratum of air disturbed during its passage over it is at any rate less than four inches thick. In other words, the plane is sustained by the compression and elasticity of an air layer not deeper than this, which we may treat, for all our present purposes, as resting on a *solid support* less than four inches below the plane. (The reader is again reminded that this sustenance is also partly due to the action of the air above the plane.)

“I may add that these experiments with the horizontal plane, when properly executed, give results of a character to forcibly impress the spectator; for, since there is no inclination, there is no visible component of pressure to prolong the fall, yet the plane nevertheless visibly behaves as if nearly deprived of its weight. The pair of

18 × 4 inch planes, for instance, one tenth of an inch thick and weighing four hundred and sixty-four grammes, has a specific gravity of about 1,660 times that of air; yet while the retardation due to the still air in the direct fall is but 0^o·03, that due to the same air in strictly lateral motion is 1^o·50—a most noteworthy result in its bearing on the use in mechanical flight that may be derived from a property of the air much utilized by Nature, but hitherto almost wholly neglected in this connection by man—its inertia.

“The experiments consisted in measuring with a dynamometer the actual resistance to motion experienced by planes when just ‘soaring’ or supporting themselves under all the circumstances of flight in free air, except that the plane is restricted from the ‘flouncing’ caused by irregular currents, etc., and made to hold a steady flight.

“The most important conclusion may be said to be the confirmation of the statement that *to maintain such planes in horizontal flight at high speeds less power is needed than for low ones.*

“In this connection I may state the fact, surely of extreme interest in its bearing on the possibility of mechanical flight, that while an engine developing one horse power can, as has been shown, transport over two hundred pounds at the rate of twenty metres per second (forty-five miles an hour), such an engine (i. e., engine and boiler) can be actually built to weigh less than one tenth of this amount.”

Concerning a series of experiments with propellers of various forms, sizes, and materials to determine the ratio of power put out to return in end thrust obtained, Prof. Langley says:

“The whole series of experiments is not given here in detail, but their principal results will be communicated in general terms. The first result is that the maximum efficiency of a propeller in air, as well as in water, is obtained with a small number of blades. A propeller with two blades gave nearly or quite as good results as one with a greater number. This is strikingly different from the form of the most efficient windmill, and it may be well to call attention to the essential difference in the character of the two instruments, and to the fact that the windmill and the movable propeller are not reversible engines, as they might at first sight seem to be. It is the stationary propeller—i. e., the fan-blower—which is in reality the reversed windmill; and of these two the most efficient form for one is essentially the most efficient form for the other. The efficiency of a fan-blower of given radius is expressed in terms of the quantity of air delivered in a unit of time for one unit of power put out; that of the windmill may be expressed in terms of the amount of work done per unit quantity of air passing within the radius of the arms. If any air passes within the perimeter which does not strike the arms and do its work, it is so much loss of an attainable efficiency. This practical conclusion is confirmed by experience, since modern American windmills, in which practically the entire projection area is covered with the blades, are well known to be more efficient than the old windmills of four arms.

“Turning now to the propeller, it will be seen that the expression for its efficiency—viz., the ratio of useful work done to power expended—involves quite different elements. Here the usual work done (in a unit of time) is the product of the resistance encountered by the distance advanced, which is entirely different in character

from that in the fan-blower, and almost opposite conditions conduce to efficiency. Instead of aiming to set in motion the greatest amount of air, as in the case of the fan-blower, the most efficient propeller is that which sets in motion the least. The difference represents the difference between the screw working in the fluid without moving it at all, as in a solid nut, and actually setting it in motion and driving it backward—a difference analogous to that which in marine practice is technically called 'slip,' and which is a part of the total loss of efficiency, since the object of the propeller is to drive itself forward and not to drive the air backward. It may now be seen why the propeller with few blades is more efficient than one with many. The numerous blades, following after each other quickly, meet air whose inertia has already yielded to the blades in advance, and hence that does not offer the same resistance as undisturbed air or afford the same forward thrust. In the case of the propeller with two blades, each blade constantly glides upon new strata of air and derives from the inertia of this fresh air the maximum forward thrust. The reader will observe the analogy here to the primary illustration of the single rapid skater upon thin ice, who advances in safety where a line of skaters, one behind the other, would altogether sink, because he utilizes all the sustaining power to be derived from the inertia of the ice and leaves only a sinking foothold for his successors. The analogy is not complete, owing to the actual elasticity of air and for other reasons, but the principle is the same. A second observation relating to aerial propellers, and one nearly related to the first, is that the higher the velocity of advance attained the less is the percentage of 'slip,' and hence the higher the efficiency of the propeller. The propeller of maximum

efficiency is in theory one that glides through the air like a screw in an unyielding frictionless bearing, and obtains a reaction without setting the air in motion at all. Now, a reaction from the air arising from its inertia increases, in some ratio as yet undetermined, with the velocity with which it is struck; and if the velocity is high enough it is rendered probable, by facts not here recorded, that the reaction of this ordinarily most mobile gas may be practically as great as we please, and, with explosive velocities, for instance, may be as great as would be the reaction of a mass of iron.

“The theory of aërial propellers being that, for a maximum efficiency, the higher the velocity the sharper should be the pitch of the blades, it has been the object of the complete series of experiments with the dynamometer-chronograph to determine by actual trial the velocity of advance at which the maximum efficiency is attained when the blades are set at different angles, and the best forms and dimensions of the blades. The details of these are reserved for future publication, but, very generally speaking, it may be said that, notwithstanding the great difference between the character of the media, one being a light and very compressible, the other a dense and very incompressible fluid, these observations have indicated that there is a very considerable analogy between the best form of aërial and of marine propeller.

“The essential feature of the present work has been the insistence on the importance of a somewhat unfamiliar idea—that rapid aërial locomotion can be effected by taking advantage of the inertia of the air and its elasticity. Though the fact that the air has inertia is a familiar one, and though the flight of certain missiles has indicated that this inertia may be utilized to

support bodies in rapid motion, the importance of the deductions to be made has not been recognized. This work makes the importance of some of these deductions evident by experiment, and perhaps for the first time exhibits them in their true import.

“This memoir is essentially a presentation of experiments alone, without hypotheses, and with only such indispensable formulæ as are needed to link the observations together. These experiments furnish results which may be succinctly summarized as follows :

“The primary experiment with the *suspended plane* is not intended *per se* to establish a new fact, but to enforce attention to the neglected consequences of the fundamental principle that the pressure of a fluid is always normal to a surface moving in it, some of these consequences being (1) that the stress necessary to sustain a body in the air is less when this is in horizontal motion than when at rest; (2) that this stress, instead of increasing, diminishes with the increase of the horizontal velocity (a fact at variance with the conclusions of some physicists of repute, and with ideas still popularly held); (3) that it is at least probable that in such horizontal flight up to great velocities the greater the speed the less the power required to maintain it, this probability being already indicated by this illustrative experiment, while demonstrative evidence follows later.

“The experiments which are presented . . . result in an empirical curve, giving the ratio between the pressure on an inclined square plane and on a normal plane moving in the air with the same velocity. Incidentally it is shown that the pressure is normal to the inclined surface, and hence that the effects of skin friction, viscosity, and the like, are negligible in such experiments. It is also shown that for the small angles

most used in actual trial of the plane, the pressure on it is about twenty times greater than that assignable from the theoretical formula derived from Newton's discussion of this subject in the *Principia*. This last experimental result is not presented as a new contribution to knowledge, since it had previously been obtained by experimenters in the early part of this century; but as their results appear not to have met with the general attention or acceptance they deserve, it is not superfluous either to produce this independent experimental evidence or to urge its importance.

“The experiments with the *plane-dropper* introduce matter believed to be novel as well as important. They show (1) that the time of falling of a horizontal plane is greater when moving horizontally than when at rest, and (2) that this time of falling most notably increases with the velocity of lateral translation; (3) experiments with different horizontal planes show that this increase in the time of falling is greater for those planes whose extension from front to back is small compared with their length measured perpendicular to the line of advance; (4) the horizontal velocities are determined at which variously shaped inclined planes set at varying angles can *soar*—that is, just sustain their own weight in the air under such circumstances—and these data afford the numerical basis for the important proposition that the power required to maintain the horizontal motion of an inclined aëroplane is less for high speeds than for low ones; (5) by experiments with double planes, one above the other, it is shown that planes of the advantageous shape mentioned above do not interfere with each other at specified speeds, if so placed at an interval not less than their length from front to back; and it is pointed out that an extension of this method enables us

to determine the extent to which any underlying air stratum is disturbed during the plane's passage.

“The conclusions as to the weights which can be transported in horizontal flight have included the experimental demonstration that the air friction is negligible within the limits of experiment. It has not been thought necessary to present any evidence that an engine or other adjunct which might be applied to give these planes motion, need itself oppose no other than frictional resistance, if inclosed in a stream-line form, since the fact that such forms oppose no other resistance whatever to fluid motion has been abundantly demonstrated by Froude, Rankine, and others.

“The most important general inference from these experiments, as a whole, is that, so far as the mere power to sustain heavy bodies in the air by mechanical flight goes, *such mechanical flight is possible with engines we now possess*, since effective steam engines have lately been built weighing less than ten pounds to one horsepower; and the experiments show that if we multiply the small planes which have been actually used, or assume a larger plane to have approximately the properties of similar small ones, one horse power rightly applied can sustain over two hundred pounds in the air at a horizontal velocity of over twenty metres per second (about forty-five miles an hour), and still more at still higher velocities. These numerical values are contained in the following table.* It is scarcely necessary to observe that the planes have been designedly loaded till they weighed five hundred grammes each, and that such a system, if used for actual flight, need weigh but a

* See table, p. 135.

small fraction of this amount, leaving the rest of the sustainable weight indicated disposable for engines and other purposes. I have found, in experiment, that surfaces approximately plane and of 1·10 this weight are sufficiently strong for all necessary purposes of support.

“ I am not prepared to say that the relations of power, area, weight, and speed, here experimentally established for planes of small area, will hold for indefinitely large ones; but, from all the circumstances of experiment, I can entertain no doubt that they do so hold far enough to afford assurance that we can transport (with fuel for a considerable journey and at speeds high enough to make us independent of ordinary wind) weights many times greater than that of a man.

“ In this mode of supporting a body in the air, its specific gravity, instead of being, as heretofore, a matter of primary importance, is a matter of indifference, the support being derived essentially from the inertia and elasticity of the air on which the body is made to rapidly run. The most important and, it is believed, novel truth, already announced, immediately follows from what has been shown, that whereas in land or marine transport increased speed is maintained only by a disproportionate expenditure of power, within the limits of experiment in *such aërial horizontal transport, the higher speeds are more economical of power than the lower ones.*

“ While calling attention to these important and as yet little known truths, I desire to add, as a final caution, that I have not asserted that planes such as are here employed in experiment, or even that planes of any kind, are the best forms to use in mechanical flight, and that I have also not asserted, without qualification, that mechanical flight is practically possible, since this

involves questions as to the method of constructing the mechanism, of securing its safe ascent and descent, and also of securing the indispensable condition for the economic use of the power I have shown to be at our disposal—the condition, I mean, of our ability to guide it in the desired horizontal direction during transport—questions which, in my opinion, are only to be answered by further experiment, and which belong to the inchoate art or science of *aërodromics*, on which I do not enter.

“I wish, however, to put on record my belief that the time has come for these questions to engage the serious attention not only of engineers but of all interested in the possibly near practical solution of a problem, one of the most important in its consequences of any which has ever presented itself in mechanics; for this solution, it is here shown, cannot longer be considered beyond our capacity to reach.”

STUDY OF A PRACTICAL AIR SHIP.

IN a paper published in *Cassier's Magazine* of February, 1893, Mr. John P. Holland presented a very interesting study of a practical air ship. The following extracts and illustrations, reproduced through the courtesy of The Cassier Magazine Company, indicate, in a general way, Mr. Holland's suggestions as to the form and construction of such a machine :

It may assist in our study to consider what conditions are required in an aërial machine, in order that it may be safe for the experimenter, and capable of traveling a considerable distance under perfect control, and at good speed, and then to find whether we have the requisite means available.

1. It must be strong enough to endure all the strains to which it may be subjected, and have a considerable margin of safety or strength remaining.

If we employ steel for every part subject to tensile strains, hard-seasoned ash for those enduring compression, and silk for covering the aëroplanes, screws or wings, and body of our machine, there will be no occasion for employing any expensive or untried material in our experiments. This shall be shown later when we come to examine the functions of the parts that may be required in a practicable flying machine.

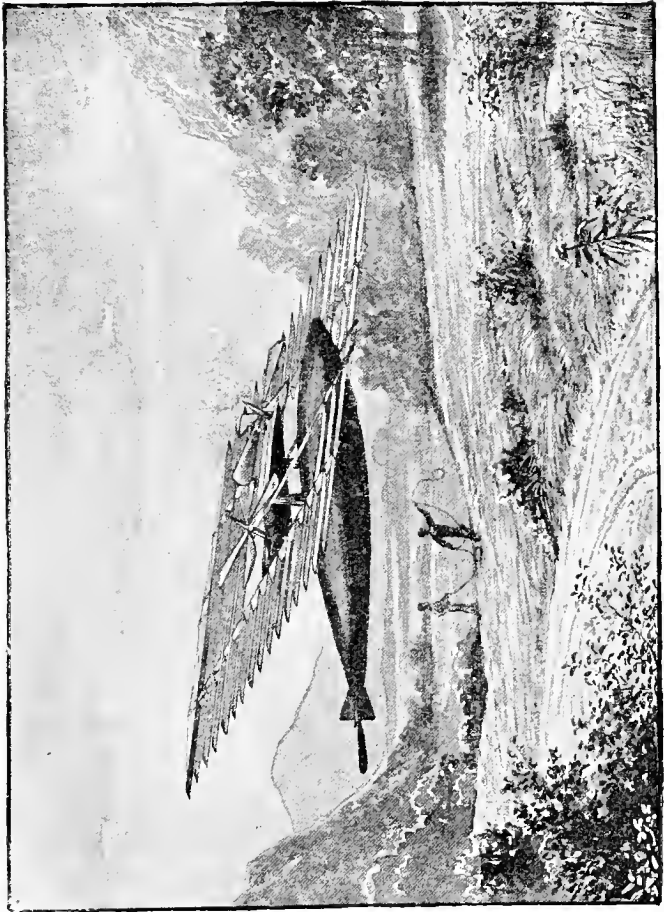

FIG. 21.—FLYING MACHINE RISING OR DESCENDING.

2. The aëronaut must be able to alight without shock or injury to himself or his machine; because, until this is assured, no one will be willing to risk getting a broken neck in the interest of aëronautics.

This is a simple matter in a machine that employs a pair of propeller screws on concentric or parallel axes capable of inclination between the horizontal and vertical positions, in connection with aëroplane surface of ample area. As a machine of this kind should be able to rise from a level surface, in still air, the power that lifts it, when rising, can be reduced so as to regulate its speed of descent and cause it to rest on the ground without injury.

If the power employed be not sufficient to lift the total weight directly, although it be enough to support it with the assistance of aëroplanes when moving horizontally, the rise and descent must be made against a strong wind, or the machine must be launched from an elevated position when starting, and rise from a low to a higher level, and rest on some elevated place when the energy due to its speed is absorbed. Observers of Nature notice that birds of all sizes face the wind, when it is considerable, both in rising and descending. The larger birds select elevated points, such as rocks or tree branches, on which to rest, so as to be able to launch themselves and attain full speed of flight with the least delay and exertion. It has also been observed that they reach those resting-places neither by descending nor by horizontal movement, but by rising from a lower level and alighting after a few vigorous wing-strokes against the direction of motion.

3. The machine must be able to travel at good speed, say thirty miles per hour at least, and steadily—that is,

without any tendency to plunging or diving, like an unbalanced kite.

The speed depends on the amount of power available and on the smallness of the surface and bulk relatively to the weight. For example, a vulture can travel six times faster than a crow, but it has only one third as much wing surface in proportion to its weight. One horse power, equal to 550 foot-pounds per second, applied to towing a flat aëroplane 184 square feet in area, weighing 118 pounds, and set at an angle of six degrees, at a speed of twenty-five miles per hour, equal to 36.66 feet per second, will overcome a resistance of $550 \div 36.66 = 15$ pounds while doing that work.

If the inclination of the plane be reduced to one degree and the speed made six times greater, the reduction of the angle reduces the lifting power to one sixth, but the increased speed raises it again as the square, or thirty-six times— $36 \times \frac{1}{6} = 6$. Therefore the same plane lifts six times as much with the new inclination and speed, and the original weight will be supported at the new speed with one sixth of the plane area.

The reduction of angle reduces the drift to one thirty-sixth, and the increase of speed raises it again thirty-six times, restoring the original resistance, fifteen pounds. When we reduce the plane area to one sixth, equal to 30.66 square feet, we reduce the drift to 2.5 pounds; but as it is exerted through six times the space in the same time, the work performed remains the same— $2.5 \times 36\frac{2}{3} \times 6 = 550$ foot-pounds = 1 horse power. Before the angle was reduced and the speed increased the proportion stood 1.56 square feet per pound weight. After the change was made the proportion became 0.166 square foot per pound weight.

If our machine have the speed, surface, and inclina-

tion of aëroplanes necessary to support its weight it will fly just as steadily as a properly balanced kite if corresponding conditions are observed—that is, if the centre of gravity is at a proper distance vertically under the centre of pressure or support, and if the point at which towing power or thrust is applied is on the intersection of the horizontal and vertical planes passing through the centre of pressure or resistance.

The chief problem awaiting solution, in the opinion of some investigators, is to find a reliable method of controlling its motions in the air, the power question having been disposed of long ago by the construction of torpedo-boat motors weighing sixty pounds per horse power; the Norwood's, nineteen pounds per horse power; Mr. Stringfellow's steam motor, weighing thirteen pounds per horse power; and Mr. Maxim's, weighing nine pounds per horse power. The impracticability of holding a thin, weak plane to its work when the speed is high and the inclination under two degrees to the horizontal, is the basis of this difficulty. Under these conditions the plane is liable to vibrate, and to lie sometimes parallel with its direction of motion, or to dip its leading edge or one of its sides, thus sustaining pressure on its upper surface on the part depressed, and causing the machine it supports to tip sidewise or plunge downward ahead. With these difficulties to encounter, steady horizontal motion and steering would be puzzling problems. However, we can avoid instead of meeting them by forming our aëroplanes in narrow superposed sections, placed far enough apart to prevent interference with each other, and by making the upper surface convex, with the greatest rise near the leading edge, and the under or pressure side slightly concave. Mr. Horatio Phillips has proved that this change increases the effi-

ciency in lifting 2.74 times without increasing the towing or drift force, and that a plane of this section left free to set its own inclination being held near the leading edge, would lie with its posterior or trailing edge at a higher level than its anterior or leading edge. As the curved shape of the upper and under surfaces, and the thick space between them, afford facilities for stiffening the planes, neither weakness nor vibration may be expected, and there remains only the question of steering a body immersed in a fluid, as a submarine boat or automobile torpedo when running submerged. It is clear that these cases are analogous, and that the aërial machine, when properly designed and constructed, can be as easily steered in every direction as the submarine boat, and by similar manual or automatic devices.

If we take some bird for the model of our machine and adopt its method of rising, progressing, and descending, the surface, weight, power, and speed will bear a certain proportion to each of these particulars in the

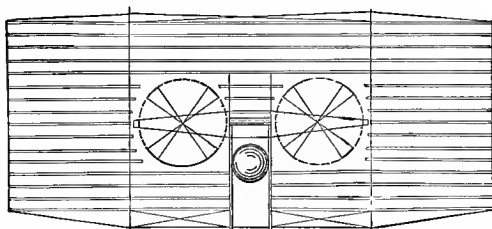

FIG 22.—APPEARANCE OF FLYING MACHINE FROM IN FRONT.

bird, provided the mechanical efficiency in each case is equal. But as this is unattainable, greater proportionate power must be provided. Some modification of other particulars must also be made to fit it for being controlled by a more inexperienced operator.

The rules relating to the ratios between models and the things they represent may be quoted as follows :

Proportionate power is as the cube of the ratio of some similar linear dimensions.

Proportionate weight is in the same ratio.

Proportionate surface is as the square of the ratio of similar linear dimensions.

Proportionate speed is as the square root of the ratio of similar linear dimensions.

Having advanced reasons for believing that a man can fly with wings, our next step will be to find whether a practicable solution of the problem of air navigation is attainable with a machine of simple design and of less exact construction than is required in one modelled on a bird.

The question stands thus : Can we build a kite, or its equivalent, large and strong enough, and push or tow it fast enough through the air to support itself, its motor and accessories, and some weight besides its operators? Can we cause it to rise from a level and descend without accident, and travel steadily in any desired direction?

A study of the things available and what we require of them will assist us to estimate our chances of success.

The size and capacity of our machine and its accessories will be determined by the power of the motor employed, and this must be large, because a small one will not do as much work in proportion to its weight and consumption of fuel—that is, it cannot be so economical.

Suppose we employ steam engines and a boiler capable of indicating four hundred horse power and a pair of air propeller wheels revolving in opposite directions.

We will deduct ten per cent for friction in the machinery, and if our air propellers prove to be as effective as some that have been tested they will give an efficiency

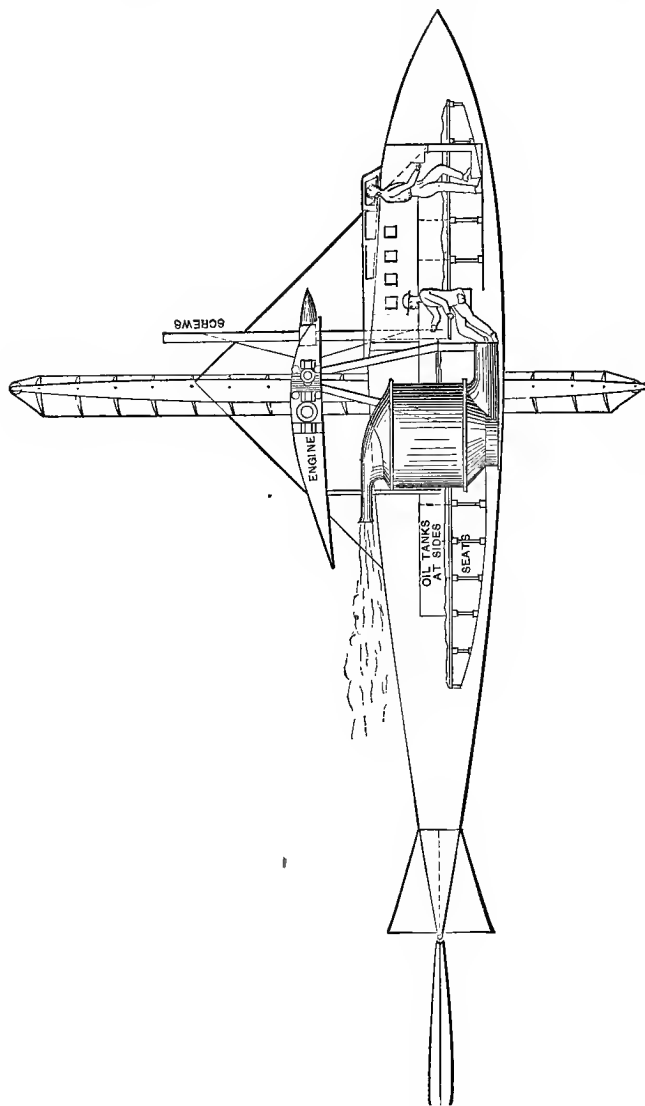

FIG. 23.—SIDE ELEVATION SECTION, SHOWING MOTOR.

of over eighty per cent, thus rendering effective seventy-two per cent, or two hundred and eighty-eight of the four hundred indicated horse power.

The propeller wheels are placed on parallel or concentric axes capable of inclining from the vertical to the horizontal position, and *vice versa*. Their power is first applied to lifting the machine vertically. When all elevated objects are cleared, the screw shafts are gradually inclined from the vertical, thus bringing a horizontal force, proportional to the size of the angle of inclination to the vertical into action at the expense of the elevating force. The latter can afford to suffer a considerable diminution before being reduced to a point at which it could no longer support the weight of the machine, because the weight to be lifted must be so proportioned that the power cannot only lift it at the start, but also give it a considerable upward velocity, say three feet per second. The weight multiplied by this speed is equal to the power spent in imparting upward velocity while ascending, and also what is available for beginning horizontal motion, and calling the aëroplanes into action. Every succeeding degree added to the inclination reduces the direct lift; but as there is a corresponding supporting power developed by the aëroplanes, the machine will lose nothing in elevation. This process continues until all the power is applied directly to propulsion or drift, the weight of the machine being supported by the corresponding lifting power developed by the aëroplanes.

In order to descend, the method of managing the ascent must be reversed, but the operation may be completed much more rapidly. In both cases the speed of the wind must be taken account of by facing the wind and by beginning the ascent and finishing the descent

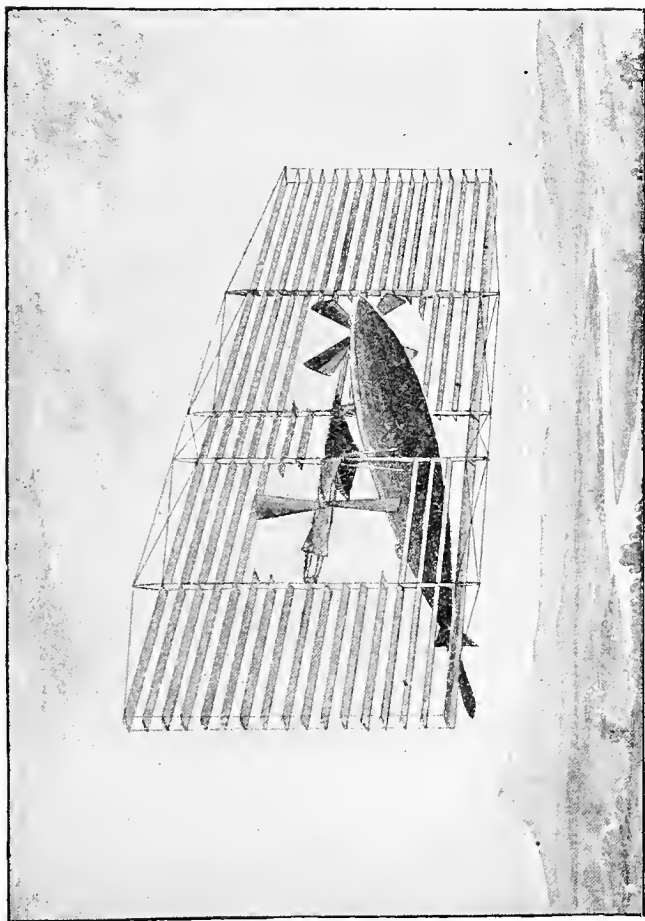

FIG. 24.—MACHINE IN FULL HORIZONTAL FLIGHT, SEEN FROM THE RIGHT AND UNDER.

with an inclination of the screw shafts, capable of imparting a horizontal velocity that compensates for the wind's speed in the opposite direction. The path, both in ascent and descent, will be represented by a vertical and a horizontal line connected by a curve to which each will be tangent.

The lifting power of screws next claims consideration; and it may be said that the experiments made with this object in view, the particulars of which have been published, have been indecisive and unsatisfactory, owing chiefly to the unsuitable proportions of the screws employed. Other defects have interfered with efficiency in some cases, but this one was found present invariably.

Mr. Maxim did not construct his screws for lifting, but to be effective when moving horizontally, and for that purpose they appear to be unexcelled. A combination of the two qualities—great lifting power and efficiency when moving rapidly—is what we require, and it is evident that we shall have it if we can construct a screw having a very short pitch or small inclination relatively to its transverse axis while it is employed in lifting, and that can automatically alter its pitch as the thrust or lifting power is reduced. There are many devices in existence for so changing the pitch, and almost any of them will answer our purpose. The efficiency in pushing was, with one of Mr. Maxim's screws, 81.45 per cent. One horse power per second is 550 pounds lifted one foot. The same percentage of this will be $550 \times 81.45 = 447.97$ foot-pounds. That is, one horse power can lift 447 pounds one foot high per second with either screw or aeroplane when properly designed. We want to lift our machine three feet high per second, therefore it may have a weight of $447 \div 3 = 149$ pounds per effective horse power provided. This degree of efficiency

would be quite unattainable with flat surfaces in screws and aëroplanes, and even if it were approached it could not be maintained with the materials suitable for a flying machine on account of their want of rigidity and stability when set at small angles.

The accompanying diagram (see Fig. 25) may suggest an explanation of the great efficiency of the convexed and concaved planes. The direction of motion of plane is indicated by the arrow on its section. The air-stream

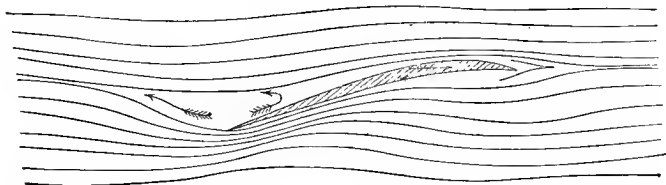

FIG. 25.—PROBABLE ARRANGEMENT OF STREAM LINES DURING MOVEMENT OF CONVEXED AND CONCAVED PLANE.

lines begin to be formed in advance of the plane, acting as if they felt its approach, and dividing at a slightly higher level than its leading edge. Those that pass below are bent downward, but recurve quickly, owing to the fluid pressure and the elasticity of the air, and they strike the under side of the blade in a direction approaching the normal on account of the recurving and the concaving of the surface. The part that recurves has its effectiveness increased as the square of the velocity due to elasticity, and this is in addition to the pressure due to the speed of passage and inclination of the blade.

The stream lines passing over the blade are bent upward and left behind by the rapidly advancing plane. The elasticity and pressure of the air cause them to

recurve downward, but not fast enough to lie against the back of the plane, where in consequence defective pressure must exist. This defective pressure or partial vacuum is made more intense by the rubbing of the streams against what air may follow the blade, thus drawing it away by friction or suction, and its intensity is increased probably as the square of the speed up to perfect vacuum. As the partial vacuum on the back is exerted in a direction opposite to the line of progress of the plane, it is just as effective as an equivalent positive pressure against the under side of the plane.

An air screw with a flat under surface and convexed back will operate efficiently when both the leading and trailing edges are on the plane of the direction of motion of the blades—that is, when the apparent angle of incidence of the air on the under surface is nothing. This condition of negative slip in marine screws is wasteful of power on account of the great increase of friction; but it is well known that, when all longitudinal sections are ship-shaped, the question of air friction may be neglected with aërial machines.

We have available 288 effective horse power, and it has been shown that we can lift 149 pounds per horse power and elevate it at a speed of three feet per second. If the speed of rising be reduced, the weight may be increased correspondingly.

$$149 \times 288 = 42,912 \text{ pounds.}$$

With a lifting force of 149 pounds per horse power at our disposal, there is scarcely any necessity for expending much ingenuity in the construction of very light engines, especially if they prove to be very costly. Motors similar to those employed on some launches, but modified to suit the circumstances, would serve our purpose quite well enough. We shall find, however, that a

motor of great strength and lightness can be built for very little more money than should be paid for first-class launch engines, specially built. Prof. Albert F. Zahm has shown us how a very light boiler may be built. "A boiler, for example, of quarter-inch tubes possesses sixteen times as much heating surface, and consequently sixteen times as much evaporative power, as a boiler of equal weight of four-inch tubes." For the same power the weight would then be only one sixteenth.

The action of the motor may be made perfectly automatic, as the fuel burned will be petroleum. It will require no extra care in handling, as there will be no variation of the power from the start until it is reduced when preparing to descend. The relative gain of power due to reduction of weight by fuel consumption will be spent on increasing the speed.

In order that our machine may be compact, yet speedy and manageable, we must have as little aëroplane surface, and of as little spread, as possible. To determine its area we must find what speed can be made.

Two hundred and eighty-eight horse power is equal to 158,400 foot-pounds per second.

Ninety miles speed per hour is equal to 132 feet per second; 158,400 foot-pounds ÷ 132 feet per second is equal to 1,200 pounds drift force.

$$\begin{array}{r} \text{Total lifting power} \dots\dots\dots 42,912 \\ \text{Total drift power} \dots\dots\dots 1,200 \end{array} =$$

35.67 = ratio of lift to drift force.

$$\begin{array}{r} \text{Ratio of lift to drift} \dots\dots\dots 35.67 \\ \text{Coefficient for convexed planes.} \quad 2.74 \end{array} = 13 =$$

ratio of lift to drift for flat plane with square edges. By consulting Mr. Chanute's table we shall find that this corresponds with an inclination of about 4.5 degrees. The wind pressure due to ninety miles speed—

40·5 pounds—multiplied by the drift coefficient for 4·5 degrees, gives the drift pressure per square foot of aëroplane :

$$40\cdot5 \times 0\cdot01245 = 0\cdot5042 \text{ pounds drift per square foot.}$$

Total drift force, 1,200 pounds, divided by drift per square foot.

0·01245 gives the extent of aëroplane surface required.

$$\frac{1,200}{0\cdot01245} = 2,379 \text{ square feet surface.}$$

This surface may be most conveniently disposed by arranging it in fifteen superposed planes, each eighty feet long, two feet wide, and spaced two feet apart.

The spindle-shaped body of the machine that carries the machinery and operators will be placed under the centre of the set of planes, with the axes of the screws slightly under the centre of pressure when moving horizontally. The centre of gravity may be four to six feet under the centres of pressure and support by this arrangement. (See Figs. 23 and 24.)

The trussed frame carrying the engines and screws will be solidly connected to the frame carrying the aëroplanes, the screw shafts being placed at right angles with the plane of their trunnioned ends. The aëroplanes, engines, and screws revolve together through ninety degrees during the change from vertical to horizontal motion during the ascent, and return during the descent.

In order to make room for the body and screws, an open space must be provided in the set of aëroplanes, and compensation for the corresponding loss of surface must be made by adding a sixteenth plane.

When the machine lies on the ground the aëroplane frame will be nearly horizontal, and it will stand nearly

at right angles to the axis of the body when moving horizontally. (See Figs. 21 and 24.)

As we have so large a margin of carrying power, there is no necessity for going closely into an estimate of the weight. Each aëroplane will require the equivalent of an ash pole eighty feet long, and about two and a half inches in diameter. The frame carrying it will require two thirty-foot pieces about one inch thick, and six inches wide at the centre. The body will require the equivalent of four sixty-foot pieces about three inches in diameter, with a small floor and hoops.

The wood required for the whole structure may be roughly estimated as equal to twenty-four eighty-foot poles, two and a half inches in diameter, and tapering to the ends. Their weight will be—

$$24 \times 80 \times .034 \text{ square feet} \times .6 \text{ for taper} \times 50 \text{ pounds} \\ = 1,958 \text{ pounds.}$$

Allow one half as much for ribbon stays of steel, and ash struts, say 1,000 pounds—total, 3,000 pounds.

The machine weighs 3,000 pounds.

The motor complete and water, 5,200 pounds.

Total weight of machine and motor, 8,200 pounds.

Total weight, $\frac{8,200}{288} = 28.4$ pounds per effective

Effective power, 288

horse power.

It is clear that everything may be four times heavier and yet be within practicable limits.

The consumption of petroleum will be about one pound per horse power per hour. The mean weight, if only oil for fuel be carried, is equal to one half the sum of the total lifting power, and the weight of the complete machine, without fuel :

$$\frac{42,912 + 8,200}{2} = 25,556. \quad \text{This divided by the lift-}$$

ing power of one horse power gives the mean power required.

$25,556 \div 149 = 175$ horse power. As each horse power requires one pound of oil, there will be a mean consumption of 175 pounds per hour. Carrying power, $42,912 - 8,200 = 34,712$ pounds of oil ; say 34,000 pounds, to allow for crew and supplies.

$34,000 \div 174 = 194$ hours' flight, and supposing the mean speed to be no higher than ninety miles per hour, the distance covered will be $194 \times 90 = 17,460$ miles, or about one half that distance with one half of the carrying capacity devoted to fuel and the remainder to cargo.

THE SOARING OF BIRDS AND OF MEN.

NOTHING connected with the study of problems of aërial navigation has engaged more attention, and nothing has remained more completely within the domain of speculation, than the means by which soaring birds maintain their elevation and the constancy of their movement in the air, with wings motionless, and every feather apparently at rest. The explanation of such soaring has been sought by scientific men for a century past.

At last light seems to have been thrown on this also by a paper prepared by Prof. Langley for the Conference on Aërial Navigation, at Chicago, in 1893. He furnishes a possible explanation of soaring in connection with what he calls "The Internal Work of the Wind." Very briefly stated, he finds by careful experiment that the movement of given portions of the air in the advancing mass constituting wind is not the steady movement of the wind itself. These individual portions of the whole volume change their velocity much more frequently and to a much greater extent than had heretofore been supposed. For example, let it be supposed that the velocity of the moving mass of the atmosphere

being twenty-five miles per hour, the velocity of integral parts may vary within minutes, or even within seconds, from an apparent calm to a velocity of fifty miles per hour. In this case, a heavy body carried by the wind at its mean velocity of twenty-five miles per hour, would, when passing through a period of total calm, be subjected to an impulse from the front of twenty-five miles per hour, and during the period of fifty miles forward velocity to an impulse from the rear of twenty-five miles per hour. Soaring birds are heavy, and their weight tends to maintain by inertia the velocity with which the general movement of the current propels them. They have, therefore, viewed as aëroplanes, only to elevate their forward edges during a calm, and their rear edges during an air movement greater than the mean velocity of the wind, to be in command of a lifting power which calls for no material muscular exertion. Having gained a higher elevation, they can soar forward with a slight descent against a strong wind.

This is hardly more than an intimation of the elaborate, carefully worked out and illustrated theory by which Prof. Langley seems not only to account for the soaring of birds, but to demonstrate the possibility of a like power to be gained for soaring machines or aëroplanes having sufficient weight to maintain their inertia. He evidently believes it possible that, by the use of this internal work of the wind, flying machines may be made to travel, except during calms, without making use of their motor appliances, or, to use his own words: "Fi-

nally, these observations and deductions have, it seems to me, an important practical application, not only as regards a living creature, like the soaring bird, but still more as regards a mechanically constructed body, whose specific gravity may probably be many hundred or even many thousand times that of the atmosphere. We may suppose such a body to be supplied with fuel and engines, which would be indispensable to sustain it in a calm, and yet which we now see might be ordinarily left entirely inactive, so that the body could supposably remain in the air and even maintain its motion in any direction without expending its energy, except as regards the act of changing the inclination or aspect which it presents to the wind while the wind blew.

“The final application of these principles to the art of aërodromics seems, then, to be that, while it is not likely that the perfected aërodrome will ever be able to dispense altogether with the ability to rely at intervals on some internal source of power, it will not be indispensable that this aërodrome of the future shall, in order to go any distance—even to circumnavigate the globe without alighting—need to carry a weight of fuel which would enable it to perform this journey under conditions analogous to those of a steamship, but that the fuel and weight need only be such as to enable it to take care of itself in exceptional moments of calm.”

INDEX.

- Accidents to air ships in flight, effect of, 161.
- Aërial navigation, compared with railroad travel, 127, 160.
- Aëroplane, aspects of, 133.
- bird an animated, 112, 113.
- compared with skaters on thin ice, 171, 177.
- computation of capacity by velocity and angle, 115.
- efficiency dependent on proportion of width to length and on aspect, 170.
- form of, 189.
- influence of edge, 154.
- influence of velocity on supporting power and on force required for propulsion, 138.
- load supported per horse power, 139.
- moving at an angle creates resistance, 114.
- optima angle for, 115.
- should travel at least thirty miles per hour, 186.
- specific gravity a matter of indifference with, 182.
- suggested by Maxim, 142.
- to rise and descend against the wind, 186.
- Aëroplanes, Langley's experimental, 131.
- soaring of, 171.
- Aëroplanes, stream lines for, 155.
- superposed, 134, 138, 173, 198.
- with sufficient velocity, air acts as solid support for, 171.
- Air friction, negligible within certain limits, 129, 159, 181.
- Air ship in calm weather, 32.
- Anchored halloons, 40.
- Atmospheric currents, 104.
- pressure, elevation, and ballast, 29.
- Avanzini, law of, 94.
- Backflow, or slip, 138, 177.
- Ballast, atmospheric pressure and elevation, 29.
- Balloon, an unstable buoy, 30.
- as air ship, requirements of, 37.
- first sent up by Montgolfier, 2.
- first sent up with gas, 3.
- first ascent with passengers, 3.
- "La France," experiment with, 59.
- Balloons, anchored, 40.
- at various elevations, 28.
- compared with buoys, 23, 30.
- compared with submerged vessels, 25.
- conclusions concerning, 117.
- early improvements in, 4.
- in French army in Tonquin, 11.
- in military manœuvres in France, 10, 13.
- in the Dutch army, 17.

- Balloons, results reached in propelling machinery for, 52.
 results reached with different forms, 57.
- Bird, an animated *aéroplane*, 113.
- Birds' flight, 5, 64, 73.
 force consumed in, 74, 101.
 less exertion expended in full flight than in its beginning, 75.
- Birds, number of wing-strokes per second, 76.
- Birds' speed depends on smallness of bulk relatively to weight, 187.
- Birds' wings, double function of, 121.
 movable *aéroplanes*, 112.
- Boy's kite, 69.
- Brettonnière, computation of angles in the hovering of the stork, 85.
- Calm weather, air ship in, 32.
- Capacity of *aéroplane*, computed by velocity and angle, 115.
- Centrifugal force, effects on experiments with whirling table, 140.
- Chalais, *aërostatic* installation, 53.
 experiments at, 34.
- Chanute's elements of resistance, 159.
- Currents, atmospheric, 104.
- Drzewiccki, calculations, 110, 112.
 on double function of birds' wings, 121.
 results of his investigations, 121.
- Dupuy de Lôme, improvements in elongated balloons, 117.
- Eiffel Tower, meteorological observations at, 5, 106.
- Electric motors, 54.
- Elevation, atmospheric pressure, and ballast, 29.
- Elongated balloons, stability of, 117.
- Engines; see MOTORS, also STEAM ENGINES.
- Experiments in *aërodynamics*, 167.
- Falcon, flight of, 81, 101.
- Flight of birds, 5, 64, 73.
 force consumed, 74.
 more exertion expended in beginning than in continuing, 75.
- Flight, rowing, 73.
 sailing, 89.
 sailing, only in wind, 126.
 sailing, compared with sailing of boats, 90.
 soaring, only in calm, 126.
- Floating or soaring appliances, 109.
- Flying machines, accidents to, 161.
 angle and drift of, 187.
 Maxim's experimental, 142.
 should travel at least thirty miles per hour, 186.
 speed depends on smallness of bulk relative to weight, 187.
 steering, 188.
 to rise and descend against the wind, 186.
- Freninge's propeller wheel, 151, 159.
- Friction, skin, negligible, 129, 159, 181.
- Galvanic columns, 54.
- Gas, hydrogen, lifting force of, 26.
- Giffard's increase of length of balloons, 117.
- Holland, John P., action of screws in rising, travelling, and landing, 153.
 calculations for construction of practical machine, 160.

- Holland, John P., conditions required, 184.
 flying machine with two broad aëroplanes, 156.
 flying machine with superposed planes, 162, 164, 165, 184, 188.
 flying machines, carrying power of, 160.
 paper in Cassier's Magazine, 184.
 prize paper in Cosmopolitan Magazine, 149.
 recommends screw propeller and aëroplanes, 149.
 requirements for navigating the air, 149.
 study of practical air ship, 184.
- Horizontal speed, 132, 147, 171, 186.
 thrust of screw, 136, 151, 175.
- Hovering flight, 80.
 angle of, 83, 87.
- Hovering toys, 96, 99, 100, 101.
- Hydrogen gas, lifting force of, 26.
- Internal work of the wind, Langley, 201.
- Jeffries, Dr. John, a Harvard graduate, crossed Dover Straits, 1785, 3.
- Kite, boy's, 69.
- Krebs and Renard's experiments, 118.
- Langley, Prof. S. P., aëroplane may support nine times its own weight, 182.
 air friction negligible within certain limits, 181.
 experimental aëroplanes, 131.
 experiments in aërodynamics, 167.
 internal work of the wind, 201.
 mechanical flight possible with engines now available, 181.
- Langley, Prof. S. P., reference to his experiments, 125.
 study of screw propellers, 136.
 summary of results of experiments with propellers, 176.
 whirling table, 169.
 with aëroplanes specific gravity a matter of indifference, 182.
 "Le plus lourd que l'air," 109, 120.
- Lifting force of hydrogen, 26.
- Load supported per horse power by aëroplanes, 139.
- Longitudinal instability, 34.
- Marey, calculations of angles and velocity, 86.
- Maxim, H. S., aëroplanes suggested by him, 142.
 efficiency of his propellers, 194.
 experiments in steering, 146.
 method of trial recommended, 144.
 prize paper in Cosmopolitan Magazine, 144.
- Mechanical flight, early experiments in (foot-note), 2.
 possible with means now available, 181.
- Military importance of aërial navigation, 10.
- Montgolfier, sent up first balloon, 1783, 2.
- Motors, comparison of, 55.
 electric, 54.
 examples of light, 150.
 for balloons, relation of power to weight in different experiments, 118.
 now available for mechanical flight, 181.
 weight per horse power, 139, 150, 188, 197.

- Nadar's balloon, "The Giant," 8.
 balloon postal service during
 siege of Paris, 10.
 principle, "Le plus lourd que
 l'air," 7, 9, 109, 120.
- Nineteenth century may still see
 practical results, 166.
- Optimal angle for aeroplanes, 115.
- Parachute, 92.
- Paris, siege of, balloon service dur-
 ing, 10.
- Petroleum as fuel, 199.
- Photography, chronometric, applied
 by Marey, 5.
- Plus lourd que l'air; see "LE PLUS
 LOURD QUE L'AIR."
- Power, effective, of motors, 196.
 weight, surface, and speed, ratio
 between, 190.
- Propellers, screw, analogy between
 aerial and marine, 178.
 angle and form for blades, 196.
 changing angle for lifting, for
 driving, and for descending,
 192.
 different from windmill or sta-
 tionary blower, 137, 176.
 efficiency of, 136, 151, 175, 194.
 Frenage's, 151, 159.
 Holland's, 159.
 Langley's experiments with, 136.
 lifting power of, 151, 194.
 maximum efficiency with small
 number of blades, 137, 176.
 with two blades glides on undis-
 turbed strata of air, 177.
 the higher the velocity the less
 the slip, 177.
- Propelling balloons, results reached
 with machinery for, 52.
- Propelling force decreases as ve-
 locity increases, 130, 168, 175.
- Railroad travel compared with aëri-
 al navigation, 127.
- Renard, Commandant, 22.
 experiments of, 52.
 and Krebs, experiments of, 118.
- Resistance of aeroplane moving at
 an angle, 114.
 the elements of, Chanute's, 159.
- Rowing flight, 73.
- Sailing flight, 89.
 compared with sailing of boats,
 90.
- Screws, action of, in rising, travel-
 ling, and descending, 153.
- Screw propellers; see PROPELLERS.
- Slip, 138, 177.
- Soaring of birds and of men, 201.
- Soaring velocities, 132.
- Speed dependent on power, form,
 size, and weight, 44.
 with reference to that of the
 wind, 45.
 see also VELOCITY.
- Specific gravity a matter of indif-
 ference with aeroplanes, 182.
- Stability of elongated balloons,
 117.
- Steam engines as motors, 191.
- Steering, 6, 146, 188.
 Maxim's experiments in, 146.
- Storks, flight of, 83.
- Stream-lines for aeroplanes, 129,
 195.
- Superposed aeroplanes, 134.
- Surface friction may be disregarded,
 129, 159, 181.
- Swaying of flying machine in the
 air, how prevented, 147.
- Tissandier's improvements, 117.
- Tonquin, balloon service in war
 with, 11.

- Velocity, increased, secures firmer support by the air, 77.
 influence on supporting power and on force required to propel aeroplanes, 77, 138.
 more important than lifting power, 118.
 of propellers, the higher, the less the slip, 177.
 of wind, 50.
 required for practical solution of the problem, 51.
 see also **SPEED**.
- Weight of engines and boilers, 150, 197.
 of machine suggested by Holland, 199.
- Weight per horse power that can be supported by aeroplane, 139.
 Whirling table (Langley's), 128.
 Wind, as affecting the sailing of air ships, 42.
 as an obstacle, 38, 40.
 does not exist for the aeronaut, 41.
 internal work of the, 201.
 maximum velocity of, 50.
 Wings, angle of, in relation to velocity, 86.
 Wing-strokes, number per second of different birds, 76.
- Zones of equilibrium, 29.

MODERN SCIENCE SERIES.

Edited by Sir JOHN LUBBOCK, Bart., F. R. S.

THE CAUSE OF AN ICE AGE. By Sir ROBERT BALL, LL. D., F. R. S., Royal Astronomer of Ireland; author of "Star Land," "The Story of the Sun," etc.

"Sir Robert Ball's book is, as a matter of course, admirably written. Though but a small one, it is a most important contribution to geology."—*London Saturday Review*.

"A fascinating subject, cleverly related and almost colloquially discussed."—*Philadelphia Public Ledger*.

THE HORSE: A Study in Natural History. By WILLIAM H. FLOWER, C. B., Director in the British Natural History Museum. With 27 Illustrations.

"The author admits that there are 3,800 separate treatises on the horse already published, but he thinks that he can add something to the amount of useful information now before the public, and that something not heretofore written will be found in this book. The volume gives a large amount of information, both scientific and practical, on the noble animal of which it treats."—*New York Commercial Advertiser*.

THE OAK: A Study in Botany. By H. MARSHALL WARD, F. R. S. With 53 Illustrations.

"From the acorn to the timber which has figured so gloriously in English ships and houses, the tree is fully described, and all its living and preserved beauties and virtues, in nature and in construction, are recounted and pictured."—*Brooklyn Eagle*.

ETHNOLOGY IN FOLKLORE. By GEORGE L. GOMME, F. S. A., President of the Folklore Society, etc.

"The author puts forward no extravagant assumptions, and the method he points out for the comparative study of folklore seems to promise a considerable extension of knowledge as to prehistoric times."—*Independent*.

THE LAWS AND PROPERTIES OF MATTER. By R. T. GLAZEBROOK, F. R. S., Fellow of Trinity College, Cambridge.

"It is astonishing how interesting such a book can be made when the author has a perfect mastery of his subject, as Mr. Glazebrook has. One knows nothing of the world in which he lives until he has obtained some insight of the properties of matter as explained in this excellent work."—*Chicago Herald*.

THE FAUNA OF THE DEEP SEA. By SYDNEY J. HICKSON, M. A., Fellow of Downing College, Cambridge. With 23 Illustrations.

"That realm of mystery and wonders at the bottom of the great waters is gradually being mapped and explored and studied until its secrets seem no longer secrets. . . . This excellent book has a score of illustrations and a careful index to add to its value, and in every way is to be commended for its interest and its scientific merit."—*Chicago Times*.

Each, 12mo, cloth, \$1.00.

EVOLUTION SERIES, NOS. 1 TO 17.

Popular Lectures and Discussions before the Brooklyn Ethical Association.

EVOOLUTION IN SCIENCE, PHILOSOPHY,
AND ART. With 3 Portraits. Large 12mo. Cloth, \$2.00.

CONTENTS.

<i>Alfred Russel Wallace.</i> By EDWARD D. COPE, Ph. D.	<i>Form and Color in Nature.</i> By WILLIAM POTTS.
<i>Ernst Haeckel.</i> By THADDEUS B. WAKEMAN.	<i>Optics as related to Evolution.</i> By L. A. W. ALLEMAN, M. D.
<i>The Scientific Method.</i> By FRANCIS E. ABBOTT, Ph. D.	<i>Evolution of Art.</i> By JOHN A. TAYLOR.
<i>Herbert Spencer's Synthetic Philosophy.</i> By BENJAMIN F. UNDERWOOD.	<i>Evolution of Architecture.</i> By Rev. JOHN W. CHADWICK.
<i>Evolution of Chemistry.</i> By ROBERT G. ECCLES, M. D.	<i>Evolution of Sculpture.</i> By Prof. THOMAS DAVIDSON.
<i>Evolution of Electric and Magnetic Physcs.</i> By ARTHUR E. KENNELLY.	<i>Evolution of Painting.</i> By FORREST P. RUNDELL.
<i>Evolution of Botany.</i> By FRED J. WULLING, Ph. G.	<i>Evolution of Music.</i> By Z. SIDNEY SAMPSON.
<i>Zoölogy as related to Evolution.</i> By Rev. JOHN C. KIMBALL.	<i>Life as a Fine Art.</i> By LEWIS G. JANES, M. D.
	<i>The Doctrine of Evolution: its Scope and Influence.</i> By Prof. JOHN FISKE.

"The addresses include some of the most important presentations and epitomes published in America. They are all upon important subjects, are prepared with great care, and are delivered for the most part by highly eminent authorities."—*Public Opinion.*

EVOLUTION SERIES, NOS. 18 TO 34.

MAN AND THE STATE. Studies in Applied Sociology. With Index. Large 12mo. Cloth, \$2 00.

CONTENTS.

<i>The Duty of a Public Spirit.</i> By E. BENJAMIN ANDREWS, D. D., LL. D.	<i>The Monetary Problem.</i> By WILLIAM POTTS.
<i>The Study of Applied Sociology.</i> By ROBERT G. ECCLES, M. D.	<i>The Immigration Problem.</i> By Z. SIDNEY SAMPSON.
<i>Representative Government.</i> By EDWIN D. MEAD.	<i>Evolution of the Afric-American.</i> By Rev. SAMUEL J. BARROWS.
<i>Suffrage and the Ballot.</i> By DANIEL S. REMSEN.	<i>The Race Problem in the South.</i> By Prof. JOSEPH LE CONTE.
<i>The Land Problem.</i> By Prof. OTIS T. MASON.	<i>Education and Citizenship.</i> By Rev. JOHN W. CHADWICK.
<i>The Problem of City Government.</i> By Dr. LEWIS G. JANES.	<i>The Democratic Party.</i> By EDWARD M. SHEPARD.
<i>Taxation and Revenue: The Free-Trade View.</i> By THOMAS G. SHEARMAN.	<i>The Republican Party.</i> By Hon. ROSWELL G. HERR.
<i>Taxation and Revenue: The Protectionist View.</i> By Prof. GEORGE GUNTON.	<i>The Independent in Politics.</i> By JOHN A. TAYLOR.
	<i>Moral Questions in Politics.</i> By Rev. JOHN C. KIMBALL.

"These studies in applied sociology are exceptionally interesting in their field."—*Cincinnati Times-Star.*

"Will command the attention of the progressive student of politics."—*Pittsburg Chronicle-Telegraph.*

Separate Lectures from either volume, 10 cents each.

EVOLUTION SERIES, NOS. 35 TO 48.

FACTORS IN AMERICAN CIVILIZATION:
STUDIES IN APPLIED SOCIOLOGY. Popular Lectures
and Discussions before the BROOKLYN ETHICAL ASSOCIATION.
12mo. Cloth, \$2.00. Separate Lectures, in Pamphlet Form,
10 cents each.

This volume is uniform with the two previous volumes of the series, entitled respectively "Evolution in Science and Art" and "Man and the State."

CONTENTS.

35. *The Nation's Place in Civilization.* By CHARLES DE GARMO, Ph. D., President of Swarthmore College.
36. *Natural Factors in American Civilization.* By Rev. JOHN C. KIMBALL.
37. *What America Owes to the Old World.* By A. EMERSON PALMER.
38. *War and Progress.* By Dr. LEWIS G. JANES.
39. *Interstate Commerce.* By ROBERT W. TAYLER.
40. *Foreign Commerce.* By Hon. WILLIAM J. COOMBS.
41. *The Social and Political Status of Woman.* By Rev. JOHN W. CHADWICK.
42. *The Economic Position of Woman.* By Miss CAROLINE B. LE ROW.
43. *Evolution of Penal Methods and Institutions.* By JAMES MCKEEN.
44. *Evolution of Charities and Charitable Institutions.* By Prof. AMOS G. WARNER, Ph. D., Superintendent of Public Charities, Washington, D. C.
45. *The Drink Problem.* By T. D. CROTHERS, M. D., Editor of the "Quarterly Journal of Inebriety."
46. *The Labor Problem.* By Rev. NICHOLAS P. GILMAN, Editor of the "New World."
47. *Political Aspects of the Labor Problem.* By JEREMIAH W. SULLIVAN.
48. *The Philosophy of History.* By Rev. E. P. POWELL, Author of "Our Heredity from God," etc.

"One can hardly speak too highly of the work which is being done by the BROOKLYN ETHICAL ASSOCIATION. Its plan is to bring within definite compass and knowledge some of the largest subjects which can occupy the minds of thoughtful men. It has found students and thinkers who are equal to this task, and here we have some of the best work on subjects of the highest meaning that has been done by Americans."—*Boston Herald.*

Recent Volumes of the International Scientific Series.

A HISTORY OF CRUSTACEA. By Rev. THOMAS R. R. STEBBING, M. A., author of "The Challenger Amphipoda," etc. With numerous Illustrations. 12mo. Cloth, \$2.00.

"Mr. Stebbing's account of 'Recent Malacostraca' (soft-shelled animals) is practically complete, and is based upon the solid foundations of science. The astonishing development of knowledge in this branch of natural history is due to the extension of marine research, the perfecting of the microscope, and the general diffusion of information regarding what has been ascertained concerning the origin of species. . . . This volume is fully illustrated, and contains useful references to important authorities. It is an able and meritorious survey of recent crustacea."—*Philadelphia Ledger*.

"In all respects an admirable piece of work."—*The Churchman*.

"One of the most valuable and entertaining volumes in the series. . . . The author is master of an engaging style, and offers words of cheer and counsel to the beginner who may be dismayed by the bewildering riches of the crustacean world. Every branch of the subject treated is presented in the most interesting and significant light."—*London Saturday Review*.

HANDBOOK OF GREEK AND LATIN PALEOGRAPHY. By EDWARD MAUNDE THOMPSON, D. C. L., Principal Librarian of the British Museum. With numerous Illustrations. 12mo. Cloth, \$2.00.

"Mr. Thompson, as principal librarian of the British Museum, has of course had very exceptional advantages for preparing his book. . . . Probably all teachers of the classics, as well as specialists in palæography, will find something of value in this systematic treatise upon a rather unusual and difficult study."—*Review of Reviews*.

"A well-arranged manual from the hands of a competent authority. . . . Of the nineteen chapters contained in the volume, seven deal with preliminary topics, as the history of the Greek and the Latin alphabets, writing materials, the forms of books, punctuation, measurement of lines, shorthand, abbreviations, and contractions; five are devoted to Greek palæography, seven to Latin."—*The Critic*.

"Covering as this volume does such a vast period of time, from the beginning of the alphabet and the ways of writing down to the seventeenth century, the wonder is how, within three hundred and thirty-three pages, so much that is of practical usefulness has been brought together."—*New York Times*.

MAN AND THE GLACIAL PERIOD. By G. FREDERICK WRIGHT, D. D., LL. D., author of "The Ice Age in North America," "Logic of Christian Evidences," etc. With numerous Illustrations. 12mo. Cloth, \$1.75.

"The author is himself an independent student and thinker whose competence and authority are undisputed."—*New York Sun*.

"It may be described in a word as the best summary of scientific conclusions concerning the question of man's antiquity as affected by his known relations to geological time."—*Philadelphia Press*.

"The earlier chapters describing glacial action, and the traces of it in North America—especially the defining of its limits, such as the terminal moraine of the great movement itself—are of great interest and value. The maps and diagrams are of much assistance in enabling the reader to grasp the vast extent of the movement."—*London Spectator*.

CAMP-FIRES OF A NATURALIST. From the Field Notes of LEWIS LINDSAY DYCHE, A. M., M. S., Professor of Zoölogy and Curator of Birds and Mammals in the Kansas State University. The Story of Fourteen Expeditions after North American Mammals. By CLARENCE E. EDWARDS. With numerous Illustrations. 12mo. Cloth, \$1.50.

"It is not always that a professor of zoölogy is so enthusiastic a sportsman as Prof. Dyche. His hunting exploits are as varied as those of Gordon Cumming, for example, in South Africa. His grizzly bear is as dangerous as the lion, and his mountain sheep and goats more difficult to stalk and shoot than any creatures of the torrid zone. Evidently he came by his tastes as a hunter from lifelong experience."—*New York Tribune*.

"The book has no dull pages, and is often excitingly interesting, and fully instructive as to the habits, haunts, and nature of wild beasts."—*Chicago Inter-Ocean*.

"There is abundance of interesting incident in addition to the scientific element, and the illustrations are numerous and highly graphic as to the big game met by the hunters, and the hardships cheerfully undertaken."—*Brooklyn Eagle*.

"The narrative is simple and manly and full of the freedom of forests. . . . This record of his work ought to awaken the interest of the generation growing up, if only by the contrast of his active experience of the resources of Nature and of savage life with the background of culture and the environment of educational advantages that are being rapidly formed for the students of the United States. Prof. Dyche seems, from this account of him, to have thought no personal hardship or exertion wasted in his attempt to collect facts, that the naturalist of the future may be provided with complete and verified ideas as to species which will soon be extinct. This is good work—work that we need and that posterity will recognize with gratitude. The illustrations of the book are interesting, and the type is clear."—*New York Times*.

"The adventures are simply told, but some of them are thrilling of necessity, however modestly the narrator does his work. Prof. Dyche has had about as many experiences in the way of hunting for science as fall to the lot of the most fortunate, and this recountal of them is most interesting. The camps from which he worked ranged from the Lake of the Woods to Arizona, and northwest to British Columbia, and in every region he was successful in securing rare specimens for his museum."—*Chicago Times*.

"The literary construction is refreshing. The reader is carried into the midst of the very scenes of which the author tells, not by elaborateness of description but by the directness and vividness of every sentence. He is given no opportunity to abandon the companions with which the book has provided him, for incident is made to follow incident with no intervening literary padding. In fact, the book is all action."—*Kansas City Journal*.

"As an outdoor book of camping and hunting this book possesses a timely interest, but it also has the merit of scientific exactness in the descriptions of the habits, peculiarities, and haunts of wild animals."—*Philadelphia Press*.

"But what is most important of all in a narrative of this kind—for it seems to us that 'Camp-Fires of a Naturalist' was written first of all for entertainment—these notes neither have been 'dressed up' and their accuracy thereby impaired, nor yet retailed in a dry and statistical manner. The book, in a word, is a plain narrative of adventures among the larger American animals."—*Philadelphia Bulletin*.

"We recommend it most heartily to old and young alike, and suggest it as a beautiful souvenir volume for those who have seen the wonderful display of mounted animals at the World's Fair."—*Topeka Capital*.

Established by EDWARD L. YOUMANS.

THE POPULAR SCIENCE MONTHLY,

Edited by WILLIAM JAY YOUMANS,

Is well known as a trustworthy medium for the spread of scientific truth in popular form, and is filled with articles of interest to everybody, by the ablest writers of the time. Its range of topics, which is widening with the advance of science, includes—

Prevention of Disease and Improvement of the Race.

Agricultural and Food Products.

Social and Domestic Economy.

Political Science, or the Conduct of Government.

Scientific Ethics; Mental Science and Education.

Man's Origin and Development.

Relations of Science and Religion.

The Industrial Arts.

Natural History; Discovery; Exploration, Etc.

With other illustrations, each number contains a finely engraved PORTRAIT of some eminent scientist, with a BIOGRAPHICAL SKETCH.

Among its recent contributors are:

WILLIAM A. HAMMOND, M. D.,
HERBERT SPENCER,
DAVID A. WELLS,
T. H. HUXLEY,
SIR JOHN LUBBOCK,
EDWARD ATKINSON,
T. D. CROTHERS, M. D.,
W. K. BROOKS,
E. D. COPE,
DAVID STARR JORDAN,
T. MITCHELL PRUDDEN, M. D.,
JOSEPH LE CONTE,
APPLETON MORGAN,
FELIX L. OSWALD,
J. S. BILLINGS, M. D.,

BENJ. WARD RICHARDSON, M. D.,
ANDREW D. WHITE,
F. W. CLARKE,
HORATIO HALE,
EDWARD S. MORSE,
J. S. NEWBERRY,
WALTER B. PLATT, M. D.,
EUGENE L. RICHARDS,
THOMAS HILL,
N. S. SHALER,
D. G. THOMPSON,
AMBROSE L. RANNEY, M. D.,
GRANT ALLEN,
SIR WILLIAM DAWSON,
J. HUGHLINGS JACKSON, M. D.

Subscription price, \$5.00 per Annum.

New York: D. APPLETON & CO., 1, 3, & 5 Bond Street.

