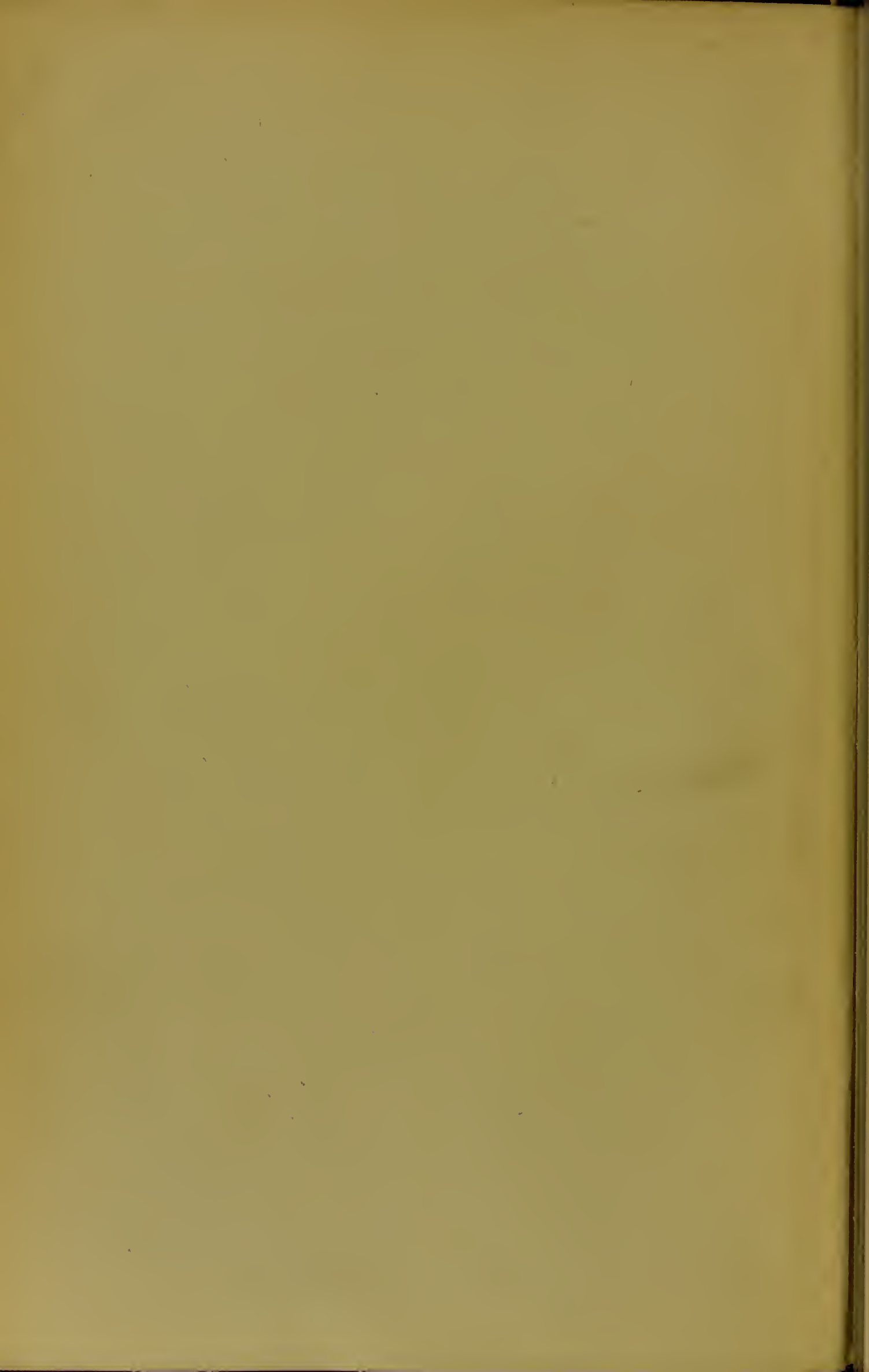


22101796776



1819





SYSTEM



OF

DISEASES OF THE EYE.

BY

AMERICAN, BRITISH, DUTCH, FRENCH,  
GERMAN, AND SPANISH AUTHORS.

EDITED BY

WILLIAM F. NORRIS, A.M., M.D., AND CHARLES A. OLIVER, A.M., M.D.,  
OF PHILADELPHIA, PA., U.S.A.

VOLUME II.

EXAMINATION OF THE EYE, SCHOOL HYGIENE, STATISTICS OF  
BLINDNESS, AND ANTISEPSIS.

*WITH THIRTEEN FULL-PAGE PLATES AND TWO HUNDRED AND FOURTEEN  
TEXT ILLUSTRATIONS.*

LONDON AND PHILADELPHIA :  
J. B. LIPPINCOTT COMPANY.

1897.

COPYRIGHT, 1897,  
BY  
J. B. LIPPINCOTT COMPANY.

M20514

WELLCOME INSTITUTE LIBRARY	
Coll.	we'MOmec
Call	
No.	WW100
	1897-
	N863





## CONTENTS OF VOLUME II.

### EXAMINATION OF THE EYE, SCHOOL HYGIENE, STATISTICS OF BLINDNESS, AND ANTISEPSIS.

	PAGE
<b>ON THE METHODS OF DETERMINING THE ACUITY OF VISION.</b> By HERMAN SNELLEN, M.D., Professor of Ophthalmology in the University of Utrecht, Utrecht, Holland. Translated by GEORGE A. BERRY, M.B., F.R.C.S. Ed., Lecturer on Ophthalmology in the University of Edinburgh, Edinburgh, Scotland . . . . .	11
<b>MYDRIATICS AND MYOTICS.</b> By HERMAN SNELLEN, Jr., M.D., Ophthalmic Surgeon to the Netherlands Hospital, Utrecht, Holland . . . . .	31
<b>LATERAL ILLUMINATION: MAGNIFYING INSTRUMENTS EMPLOYED IN CONNECTION WITH LATERAL ILLUMINATION; THE USE OF HIGHLY MAGNIFYING GLASSES WITH THE OPHTHALMOSCOPE.</b> By L. LAQUEUR, M.D., Professor of Ophthalmology and Director of the Ophthalmological Clinic in the University of Strassburg, Strassburg in Alsace, Germany. Translated by HARRY FRIEDENWALD, A.B., M.D., Associate Professor of Ophthalmology and Otology, College of Physicians and Surgeons, Baltimore; Ophthalmic and Aural Surgeon to the Baltimore City Hospital, Baltimore, Md., U.S.A. . . . .	47
<b>THE OPHTHALMOSCOPE AND THE ART OF OPHTHALMOSCOPY.</b> By GEORGE M. GOULD, A.M., M.D., late Ophthalmologist to the Philadelphia Hospital, Philadelphia, Pa., U.S.A. . . . .	63
<b>SKIASCOPY (THE SHADOW-TEST, RETINOSCOPY) AND ITS PRACTICAL APPLICATION.</b> By EDWARD JACKSON, A.M., M.D., Professor of Diseases of the Eye in the Philadelphia Polyclinic; Surgeon to Wills Eye Hospital, Philadelphia, Pa., U.S.A. . . . .	89
<b>OPHTHALMOMETRY AND ITS CLINICAL APPLICATIONS.</b> By ADOLPHE JAVAL, Jr., Paris, France. Translated . . . . .	111
<b>PRISMS AND PRISMOMETRY.</b> By WILLIAM S. DENNETT, M.D., Surgeon to the New York Eye and Ear Infirmary, New York City, N.Y., U.S.A. . . . .	141
<b>THE PRINCIPLES OF AND THE METHODS FOR THE ESTIMATION OF THE BALANCE OF THE EXTRA-OCULAR MUSCLES.</b> By GEORGE T. STEVENS, M.D., Ph.D., New York City, N.Y., U.S.A. . . . .	167
<b>PERIMETRY AND ITS CLINICAL VALUE.</b> By HERMAN WILBRAND, M.D., Ophthalmic Surgeon to the General Hospital of Hamburg, Hamburg, Germany. Translated by THOMAS R. POOLEY, M.D., formerly Professor of Ophthalmology in the New York Polyclinic; Surgeon to the New Amsterdam Eye and Ear Hospital, New York City, N.Y., U.S.A. . . . .	189

	PAGE
<b>DETECTION OF COLOR-BLINDNESS.</b> By WILLIAM THOMSON, M.D., Professor of Ophthalmology in the Jefferson Medical College; Attending Surgeon, Wills Eye Hospital, Philadelphia, Pa., U.S.A. Assisted by CARL WEILAND, M.D., Chief Clinical Assistant, Eye Department, Jefferson Medical College Hospital, Philadelphia, Pa., U.S.A. . . . .	315
<b>SCHOOL HYGIENE.</b> By S. D. RISLEY, A.M., M.D., Ph.D., Professor of Ophthalmology in the Philadelphia Polyclinic and College for Graduates in Medicine; Attending Surgeon to the Wills Eye Hospital, Philadelphia, Pa., U.S.A. . . . .	353
<b>BLINDNESS: ITS FREQUENCY, CAUSES, AND PREVENTION.</b> By I. MINIS HAYS, A.M., M.D., Philadelphia, Pa., U.S.A. . . . .	419
<b>ANTISEPSIS.</b> By JOSEPH A. ANDREWS, M.D., Ophthalmic Surgeon to the Charity Hospital, New York City, N.Y., U.S.A. . . . .	463
<b>THE MICRO-ORGANISMS OF THE CONJUNCTIVA AND LACRYMAL SAC.</b> By JOSEPH MCFARLAND, M.D., Demonstrator of Pathological Histology in the University of Pennsylvania; Adjunct Professor of Pathology in the Philadelphia Polyclinic, etc., and SAMUEL STRYKER KNEASS, M.D., Adjunct Professor of Bacteriology in the Philadelphia Polyclinic, Philadelphia, Pa., U.S.A. . . . .	489



## LIST OF ILLUSTRATIONS TO VOLUME II.

### PLATES.

	PAGE
Henschen's scheme of the visual paths . . . . .	284
The solar spectrum with Fraunhofer's lines from A to H as it appears to the normal eye . . . . .	315
The spectra of potassium, lithium, sodium, thallium, and cæsium . . . . .	315
The solar spectrum of the green-blind person . . . . .	315
The solar spectrum of the red-blind person . . . . .	315
Dr. Thomson's color-stick . . . . .	318
Pen sketches of crescents of chorioiditis at the temporal margin of the optic nerve in asthenopic eyes with hypermetropic astigmatism and increasing refraction . .	360
Beginning crescent of pigment-absorption at temporal margin of disk in a case of H + Ah with chorioiditis and asthenopia . . . . .	370
Francis M. Drexel School, Philadelphia . . . . .	386
Interior suite of rooms in Francis M. Drexel School, thrown into a general assembly room . . . . .	386
School-room in which the light is admitted from the right-hand side. Old form of seat and desk, arranged with plus distance . . . . .	390
School-room lighted from the left side and the rear; window surface one-fifth of the floor surface. Suitable desk and seat, arranged with minus distance . . . . .	390
The Chandler adjustable seat and desk . . . . .	406
Measuring the length of the leg preparatory to adjusting the height of the seat . .	406
Portable desk for use at home . . . . .	416
Agar-agar culture of the bacillus mesentericus vulgatus . . . . .	489
Agar-agar culture of the bacillus megatherium . . . . .	489
Agar-agar culture of the bacillus mycoides . . . . .	489
Agar-agar culture of the cladothrix dichomata . . . . .	489
Agar-agar culture of the bacillus hirsutus . . . . .	489

### FIGURES.

Diagram illustrating dilatation of the pupil and loss of accommodation following the instillation of atropine . . . . .	34
Diagram illustrating dilatation of the pupil and loss of accommodation following the instillation of atropine . . . . .	35
Diagram illustrating spasm of the sphincter iridis and change in accommodation following the instillation of the alkaloids of Calabar bean . . . . .	42
Diagram illustrating spasm of the sphincter iridis and change in accommodation following the instillation of the alkaloids of Calabar bean . . . . .	43
Westien's binocular corneal loupe . . . . .	58
Illustration showing the arrangement of the light and the method of using Westien's binocular corneal loupe . . . . .	59
Helmholtz's original ophthalmoscope . . . . .	66
Diagram illustrating Ulrich's variation of Helmholtz's ophthalmoscope . . . . .	66

	PAGE
Diagram of Meyerstein's ophthalmoscope . . . . .	66
Rekoss's ophthalmoscope . . . . .	67
Epkens's ophthalmoscope . . . . .	68
Coccius's modification of Epkens's ophthalmoscope . . . . .	68
Ulrich's ophthalmoscope . . . . .	68
Stellwag von Carion's ophthalmoscope . . . . .	69
Liebreich's "new ophthalmoscope" . . . . .	69
Epkens-Donders's ophthalmoscope . . . . .	70
Liebreich's small ophthalmoscope . . . . .	71
Czermak's orthoscope . . . . .	71
Coccius's orthoscope . . . . .	71
Loring's ophthalmoscope . . . . .	73
Additional disk for Loring's ophthalmoscope . . . . .	73
Morton's ophthalmoscope . . . . .	74
Hawes's modification of Morton's ophthalmoscope . . . . .	75
Diagram illustrating light in the interior of the eye . . . . .	76
Diagram illustrating ophthalmoscopy with a plane mirror . . . . .	77
Diagram illustrating ophthalmoscopy with a plane mirror and a concave lens . . . . .	77
Diagram illustrating ophthalmoscopy with a plane mirror held close to the eye . . . . .	78
Diagram illustrating the indirect method of ophthalmoscopy . . . . .	79
Diagram illustrating examination of the eye by oblique illumination . . . . .	81
Diagram illustrating the recognition of opacities by their parallax movement . . . . .	81
Diagram illustrating reversal of the image . . . . .	90
Diagram illustrating movement of light on the retina caused by change in direction of a plane mirror . . . . .	91
Diagram illustrating movement of light on the retina caused by change in direction of a concave mirror . . . . .	92
Diagram illustrating the course of rays when the nodal point of the surgeon's eye is at the point of reversal . . . . .	93
Diagram illustrating movement of light in regular astigmatism . . . . .	97
Diagram illustrating the ophthalmometer of Helmholtz . . . . .	113
Ophthalmometer of Javal and Schiötz (original model, 1882) . . . . .	115
Compound objective of the ophthalmometer of Javal and Schiötz (original model, 1882) . . . . .	116
Picture of mires reflected on the cornea . . . . .	116
Ophthalmometer of Javal and Schiötz (latest model, 1889) . . . . .	118
Ophthalmometer of Javal and Schiötz (latest model, 1889) . . . . .	118
Artificial astigmatic cornea for the ophthalmometer . . . . .	119
Guide-lines on the mire in astigmatism . . . . .	121
Stepped mires in contact with the rectangular mire in astigmatism . . . . .	121
Overlapping of the mires in astigmatism . . . . .	121
Figure showing construction of a curve giving the relation between corneal astigmatism and the total astigmatism . . . . .	125
Keratoscopic image in a non-astigmatic cornea . . . . .	129
Keratoscopic image in a case of corneal astigmatism . . . . .	131
Keratoscopic image in a case of corneal astigmatism with the eye turned through an angle of $22.5^\circ$ . . . . .	131
Keratoscopic image in a case of irregular astigmatism . . . . .	132
Diagram illustrating the radius of curvature of the cornea . . . . .	133
Diagram of an eye, showing unusual decentration . . . . .	133
Ophthalmophakometer of Tscherning . . . . .	135
Diagram illustrating the adjustment of the ophthalmophakometer of Tscherning . . . . .	136
Diagram showing position of ophthalmometric images . . . . .	136
Diagram illustrating ophthalmometry of the crystalline lens . . . . .	138
Diagram illustrating ophthalmometry of the crystalline lens . . . . .	139
Diagram of a principal section of a prism . . . . .	141

	PAGE
Diagram illustrating one of the formulæ of a prism . . . . .	142
Diagram illustrating the passage of light through a plane refracting surface . . . . .	143
Diagram illustrating refraction through a prism . . . . .	144
Refraction when the radiant is in a denser medium . . . . .	146
Refraction when the radiant is in a rarer medium . . . . .	146
Diagram illustrating differences in prism units . . . . .	150
Diagram illustrating the metre-angles . . . . .	151
Appearances of three vertical lines seen through a prism . . . . .	153
Diagram showing method of using prism scales . . . . .	154
Prism scale . . . . .	155
Method of obtaining deviation . . . . .	157
Geneva Optical Company's goniometer . . . . .	157
Diagram illustrating deviation and base-apex direction . . . . .	158
Use of dividers as a goniometer . . . . .	158
Diagram illustrating the vector, graphic, and trigonometrical methods of obtaining results of combining two prisms of different strength . . . . .	161
Trial frame . . . . .	163
Noyes's bar of rhomb-shaped prisms . . . . .	164
Noyes's stereoscope . . . . .	164
Risler's prisme mobile . . . . .	165
Stevens's phorometer . . . . .	165
Maddox double prism . . . . .	166
Diagram illustrating monocular diplopia . . . . .	168
Corresponding points . . . . .	169
The visual angle . . . . .	169
Stevens's phorometer with rotating slide . . . . .	175
Rotating slide of Stevens's phorometer . . . . .	176
Rod test . . . . .	177
Stenopæic lens and handle . . . . .	178
Position of candle-flame in orthophoria . . . . .	178
Relative position of candle-flame in heterophoria . . . . .	178
The tropometer . . . . .	186
Tropometer scale as seen magnified by the ocular . . . . .	186
Scheme to illustrate the field of vision . . . . .	189
Diagram of fields of vision . . . . .	190
Diagram illustrating comparable points . . . . .	194
Förster's perimeter . . . . .	194
Ring scotoma . . . . .	198
Semicircular scotoma . . . . .	201
Zonular insular defects . . . . .	201
Semilunar defects . . . . .	202
Absolute central scotoma commencing near a peripherally concentrically contracted field . . . . .	202
Visus reticulatus . . . . .	203
Field of vision in idiopathic hemeralopia . . . . .	207
Diagram illustrating the course of the optic fibres . . . . .	209
Wilbrand's bed-perimeter . . . . .	210
Binocular fields of vision . . . . .	211
Visual field in convergent strabismus . . . . .	213
Visual field in divergent strabismus . . . . .	213
Visual field in retinal coloboma . . . . .	217
Visual field in retinal hemorrhage . . . . .	218
Visual field in cerebral syphilis . . . . .	219
Visual field in albuminuric retinitis . . . . .	220
Visual field in embolism of the central artery of the retina . . . . .	221
Visual field in embolism of the central artery of the retina . . . . .	222

	PAGE
Visual field in wound of the sclerotic . . . . .	222
Visual field in rupture of the chorioid . . . . .	223
Visual field in gunshot wound of the eyeball . . . . .	224
Visual field in detachment of the retina . . . . .	225
Visual field in retinitis pigmentosa . . . . .	227
Visual field in glaucoma . . . . .	229
Visual field in glaucoma . . . . .	230
Visual field in glaucoma . . . . .	231
Visual field in choked disk and papillo-retinitis . . . . .	232
Visual field in choked disk and papillo-retinitis . . . . .	233
Visual field in progressive optic atrophy (left eye) . . . . .	236
Visual field in progressive optic atrophy (right eye) . . . . .	236
Visual field in progressive optic atrophy . . . . .	237
Visual field in progressive optic atrophy . . . . .	238
Visual field in partial optic atrophy . . . . .	239
Subdivision of nerve-fibres in the optic nerve in the optic papilla . . . . .	241
Subdivision of nerve-fibres in the optic nerve immediately behind the optic papilla . . . . .	241
Subdivision of nerve-fibres in the optic nerve in the optic foramen . . . . .	241
Subdivision of nerve-fibres in the optic nerve in front of the chiasm . . . . .	241
Subdivision of nerve-fibres in the retina . . . . .	242
Visual field in optic atrophy . . . . .	243
Visual field in atrophy of the papilla . . . . .	244
Visual field in syphilis simulating tabes . . . . .	245
Visual field in syphilis simulating tabes . . . . .	245
Visual field in syphilis of the optic nerve . . . . .	246
Visual field in descending neuritis following cerebro-spinal meningitis . . . . .	247
Visual field in descending neuritis following cerebro-spinal meningitis . . . . .	247
Visual field in a syphilitic patient with reflex iridoplegia . . . . .	248
Visual field in optic neuritis . . . . .	250
Visual field in optic neuritis . . . . .	250
Visual field in axial neuritis . . . . .	251
Visual field in axial neuritis . . . . .	252
Visual field in intoxication amblyopia . . . . .	253
Visual field in intoxication amblyopia . . . . .	254
Visual field in intoxication amblyopia . . . . .	255
Visual field in tabes dorsalis . . . . .	258
Nerve-fibres in the optic chiasm . . . . .	262
Optic chiasm . . . . .	263
Visual field in division of the optic chiasm . . . . .	264
Overshot field of vision . . . . .	265
Visual field in gumma of the chiasm . . . . .	267
Nerve-fibres of the optic chiasm . . . . .	268
Visual field in disease of the chiasm . . . . .	271
Visual fields in a case of inferior hemianopsia . . . . .	273
Overshot field of vision . . . . .	279
Diagram illustrating the effects of overshot fields in hemianopsia . . . . .	280
Diagram illustrating overlapping of visual fields . . . . .	281
Visual field in homonymous hemianopsia . . . . .	286
Nerve-fibres in the optic tract . . . . .	290
Nerve-fibres in the optic tract . . . . .	290
Visual field in tract hemianopsia . . . . .	292
Scheme showing overshot macular fields . . . . .	305
Visual field in functional disease . . . . .	309
Visual field in functional disease . . . . .	310
Oscillating field of vision . . . . .	312
Color-curve in green-blindness . . . . .	319

	PAGE
Color-curve in red-blindness . . . . .	320
Diagram illustrating the refraction of parallel rays of light in hypermetropia, emmetropia, and myopia . . . . .	354
Chart illustrating the advancement of myopia in St. Petersburg . . . . .	355
Chart illustrating the advancement of myopia in Philadelphia . . . . .	355
Chart illustrating the advancement of myopia in Philadelphia . . . . .	366
Chart illustrating disease in relation to refraction . . . . .	367
Chart illustrating vision and pain in relation to refraction . . . . .	367
Chart illustrating disease in relation to age . . . . .	367
Curves showing the steady fall in the percentage and degree of myopia from 1874 to 1893 inclusive . . . . .	377
Bad reading position . . . . .	380
Floor-plan of modern school-building . . . . .	386
Floor-plan of old school-building . . . . .	389
Ground-plan of model school-building . . . . .	393
Model school-building. Roof garden for sports and recreation . . . . .	394
Half-section of a window . . . . .	395
Illustrating the mechanics of correct and faulty postures in sitting . . . . .	399
Faulty position assumed in writing . . . . .	400
Distortion of the trunk while working at a too high desk . . . . .	401
Proper position in upright sitting . . . . .	402
Hygienic school-desk . . . . .	404
Single standard separately adjustable seat and desk . . . . .	405
Adjustable seat and desk . . . . .	405
Adjustment of seat . . . . .	407
Kallmann's face-rest . . . . .	416
Schimmelbusch's sterilizer . . . . .	479
Kettle for Schimmelbusch's sterilizer . . . . .	479
Lautenschläger's apparatus for sterilizing . . . . .	480
Kny's sterilizer for dressings. Longitudinal section . . . . .	481
Kny's sterilizer for dressings. Front elevation . . . . .	482
Kny's water-sterilizing tanks . . . . .	482
Kny's case for surgical dressings . . . . .	483
Andrews's washing bottle . . . . .	485
Andrews's bottle for boiling solutions . . . . .	485
Hospital sterilizer . . . . .	486
Ground plan of Andrews's portable sterilizer . . . . .	486
Andrews's sterilizer enclosed in its case . . . . .	487
Andrews's sterilizer over the lamp . . . . .	487
Case containing Andrews's sterilizer, lamp, and bottles . . . . .	487
Cultures of bacillus cœrulefaciens in gelatin . . . . .	493
Cultures of bacillus hirsutus in gelatin . . . . .	502
Cultures of bacillus megatherium in gelatin . . . . .	510
Cultures of bacillus mesentericus vulgatus in gelatin . . . . .	512
Cultures of bacillus mesentericus fuscus in gelatin . . . . .	513
Cultures of bacillus mycoides in gelatin . . . . .	515
Cultures of bacillus sucinacius in gelatin . . . . .	521
Cultures of bacillus violaceus flavus in gelatin . . . . .	525





S Y S T E M  
OF  
DISEASES OF THE EYE.

---

PART II.

EXAMINATION OF THE EYE, SCHOOL HYGIENE,  
STATISTICS OF BLINDNESS, AND  
ANTISEPSIS.

---

ON THE METHODS OF DETERMINING  
THE ACUITY OF VISION.

BY HERMAN SNELLEN, M.D.,

Professor of Ophthalmology in the University of Utrecht, Utrecht, Holland.

TRANSLATED BY

GEORGE A. BERRY, M.B., F.R.C.S. ED.,

Lecturer on Ophthalmology in the University of Edinburgh, Edinburgh, Scotland.

---

*The Retinal Image.*—Visual acuteness is measured in the same way as the tactile sensibility is determined,—*i.e.*, by the minimum distance at which two simultaneous impressions give rise to two independent sensations.

The power of distinguishing two separate visual sensations requires that either or both impressions shall be clearly perceived.

Illumination of one single retinal element may be perceived, and the source of light may be indefinitely small, if only its brightness be sufficiently great.

The projection of the image of an indefinitely small source of light must at least be of a size equal to that of the projection of one retinal element, but, if brightly illuminated, irradiation will give rise to a relatively larger retinal

image, and, consequently, to a correspondingly larger projection. The clearness of perception of a retinal image depends on the number of nerve-elements involved. It seems rational to express the size of each separate image in square and not in lineal measure. The relative distinctness with which two points or disks are separately discerned depends upon the distance that separates their retinal images,—*i.e.*, upon the rows of percipient elements which lie between them. This distance represents a lineal measure. Between two separately distinguishable images there must be at least a space equal in size to that of the projection of one unilluminated percipient element.

The distinction of two retinal images, especially if they be separated by an appreciable distance, may be aided by movements of the eye.

For clinical purposes, lines are preferable to points or small disks as objects for the determination of visual acuity. Lines provide the means of determining the conditions of perceptibility over a greater retinal area, and, further, it is easier to arrange lines in complex figures than it is to arrange sets of points in the same manner.

Two lines are seen as separate more readily—*i.e.*, with a shorter intervening distance—than two points. The perception of a line may be looked upon as resulting from the perception of a series of simultaneous stimulations.

The mosaic-like arrangement of the retinal elements makes it possible for a row of unilluminated or feebly illuminated elements to occupy the space left between the nearly contiguous images of two lines.

The retinal image of a line may fall at some places upon two contiguous elements and at other places on only one element, causing the lines to appear undulated or beaded in shape.<sup>1</sup> Such an appearance affords the indication that the limit of perceptibility has been reached.

Three parallel lines of equal breadth, separated by spaces equal to the breadth of the lines, can be distinguished under a visual angle of five minutes. Taking the distance of the second nodal point to the retina as fifteen millimetres, the retinal image of the figure would have a diameter of 0.0215 millimetre, or 0.0043 millimetre for each line. Such a limit for the separation of two retinal images seems to correspond in size fairly well with that of the retinal elements. Volkmann, however, has shown that retinal images are appreciably larger than as above calculated, this being dependent upon irradiation, and, consequently, that the correspondence between the measure of the limit in question and the size of the retinal elements would entail a greater visual angle.

To answer Volkmann's objection it is merely necessary to call attention to Hense's theory, which locates the perception at the outer divisions of the cones. These, according to Max Schultze, measure only 0.001 millimetre. Our knowledge of retinal perception, however, is not sufficient to enable us, *a priori*, to establish an anatomical basis upon which to fix

---

<sup>1</sup> H. von Helmholtz, *Handbuch der physiologischen Optik*, 2te Auflage, 1887, S. 259.

the required minimum size of the retinal image. On the other hand, it may be said that the minimum visual angle under which any object is seen can be measured, and from this the size of the corresponding retinal image may be calculated.

*The Visual Angle.*—For the determination of visual acuity we measure the visual angle for distant objects, in order to obviate the influence of the power of accommodation or the necessity for glasses for focussing near objects. Another advantage of this method of determination is that the larger figures used as distant test-objects are more easily constructed than the small ones that are required as tests for shorter distances. Moreover, any inaccuracy in measuring the exact distance at which the object is seen is of less importance at a long distance than it is at a short one. Consequently tests made at a distance are in all respects more accurate than those made at short distances.

As the most suitable objects for measuring the visual angle we may select sets of three parallel lines and the correspondingly distinct figures, which can be geometrically deduced from them. These figures should be square, measuring, as far as possible, the same, both vertically and horizontally, and having interspaces equal in thickness to their component lines. Everything which might facilitate guessing at the shape of the figures must be avoided; it is, therefore, preferable to select isolated letters or figures, instead of groups which might form words or signs.

Where the acuity of vision is greatly reduced, so that the visual angle under which objects are just seen is ten times greater than normal, it is no longer possible to estimate the visual acuity with the same precision. A less accurate test is then sufficient. In such cases we may with advantage test with the fingers held apart against a black background. The normal eye can count the number of fingers held in this way at about sixty metres' distance. Movements of the hand made in front of a black surface of five times its extent can be seen normally at a distance of about three hundred metres. In any case in which only light-perception is retained while the recognition of form is lost, the visual acuity may be indicated by  $\frac{1}{\infty}$ , corresponding to a visual angle  $\infty$ .

For ordinary purposes visual tests are made with series of letters or figures, each set being drawn to a definite size. The distance at which the individual letters or figures of each set subtend an angle of five minutes to the eye is marked.

*Quantities of Test-Objects.*—The determination of the visual angle might be made with one set of equal, tolerably large letters or figures, were it not that this method would suffer from the inconvenience that in the case of sharp sight it would become necessary to have the means of placing the test-board at a considerable distance from the patient, whilst with a subject having defective vision the board would have to be brought so near that convergence and accommodation would cause disturbing influences. Although the better plan is to have various sets of letters of different sizes

at one's disposal, yet experience has shown that it is important to reduce the letters to the smallest possible number. It usually takes time and trouble to make an individual with defective sight understand where he should begin to read, unless the simplest plan be adopted of having him begin by reading aloud all the letters of the test-board, commencing at the largest letter and proceeding to the smaller ones. For this reason, it is desirable not to have any more lines or letters than are absolutely necessary. We find seven lines sufficient for the purpose if we do not insist upon the letters being read from one invariable distance.

The patient is placed at a distance of five or six metres from the board, and, after noting the smallest letters which he recognizes at that distance, we cause him to move farther from or nearer to the board, so as to get the exact distance at which these or the next smaller lines remain visible to him.

*Formula for the Value of Vision.*—The acuity of vision ( $v$ ) is expressed as the reciprocal of the smallest visual angle at which the test-object can be distinctly seen.

We measure this visual angle by comparing the distance ( $d$ ) at which the letters are just seen, divided by the distance ( $D$ ) at which they subtend an angle of five minutes to the eye.  $v = \frac{d}{D}$ .

The five-minute angle has been chosen as the standard scale, because five is a number which corresponds well with lines and letters that are divided into five parts. A visual angle of five minutes also satisfies most of the practical requirements, and may, consequently, be looked upon as fairly representing the average of normal visual acuity. This angle also represents approximately the normal acuity of vision in middle life and with moderate intensity of illumination. Yet this degree of acuity must in no sense be looked upon as a maximum. On the contrary, every normal eye in young people and under favorable conditions of illumination may lay claim to a higher acuity. Under the best conditions the letters may even be recognized at double the distance, in which case, however, the requirements of seeing each constituent part with absolute distinctness are not complied with.

Hirshman,<sup>1</sup> who at the suggestion of Helmholtz made accurate researches to determine the limit at which lines are discernible, found that under the most favorable conditions this limit corresponds to a visual angle of fifty seconds.

Uhthoff<sup>2</sup> determined for himself, in using metal wire against a bright ground under the best circumstances that he could obtain, a minimum visual angle of  $55.2''$ , corresponding to a retinal image having a diameter of 0.004 millimetre.

The equation which expresses the visual acuity in the form  $v = \frac{d}{D}$

<sup>1</sup> H. von Helmholtz, loc. cit., S. 260.

<sup>2</sup> Uhthoff, Zeitschrift für Psychologie und Physiologie der Sinnesorgane, i. 3, S. 159; v. Graefe's Archiv für Ophthalmologie, xxxvi. 1.

is only strictly applicable so long as the same test-objects are made use of for determining the value of  $d$ , a fact that is at the present time far from being universally admitted.

Since the introduction of the more rational definition of visual acuity, as expressed by the formula  $v = \frac{d}{D}$ , numerous modifications of test-types have been brought forward. Finer types, less complicated letters, and forms which are not square have been proposed; thus losing sight of the principle which is particularly insisted upon,—viz., that the letters should, as far as possible, possess the same order of distinctness as our three equally thick parallel lines with equal interspaces. It is indeed a pity that it appears to be impossible to keep to one uniform scale by which visual acuity shall be tested.

Just as formerly every town and province desired a different coinage and standard of measurement, so it appears that every school of ophthalmology must boast of its own ophthalmoscope and its own visual tests. The number of “new,” “improved,” partly copied test-letters has indeed reached a considerable amount, and additions are constantly being made to the list, most of which are not reciprocally comparable. The equation  $v = \frac{d}{D}$  is threatened with the loss of its significance when easy and difficult test-objects are placed side by side and are indiscriminately used.

Even in making use of the same optotypes at each examination it is best to state at what distance and with what number of the letters the test has been made. This is easily done by leaving the fraction  $\frac{d}{D}$  unreduced.

If, for instance, we have  $v = \frac{6}{12}$ , the numerator shows that the test has been made at six metres' distance, while the denominator states the number of type on the test-board which has been recognized. The reduction of this fraction to a decimal, according to the plan introduced by Monoyer, is unfortunately followed by many, and has become popular. Particularly is this the case in Germany, since the calculation of the amount of compensation for eye-accidents has been based on this principle.

The disadvantages which arise from the reduction of the actual equation  $\frac{d}{D}$  to a resultant decimal are, first, that it does not indicate at what distance and with what letters the test has been made; second, as a rule, the result of the testing is limited to approximate values, in consequence of the necessity of obtaining round numbers; third, it requires a definitely fixed distance, and therefore does not allow the interpolation of intermediate values by altering the distance ( $d$ ) at which the test-board can be seen; and fourth, the arithmetical series 0.1, 0.2, 0.3, etc., tends to produce a wrong impression of the proportional values of the visual acuity which are indicated by the test. The intervals are too great for the larger visual angles, and too small for the higher degrees of acuity.

This disproportion becomes obvious if we look at the sequence of objects required. In completing the series, in order to state also the acuity of vision higher than 1, we get a sequence of numbers for which the difference becomes barely appreciable (Leopold Weiss<sup>1</sup>).

To be seen at a distance of six metres the required size of letters—*i.e.*, the tangents of the visual angle—will be as follows :

	Millimetres.		Millimetres.	
For $v = 0.1$	. . . . 87.266		For $v = 1.1$	. . . . 7.9265
For $v = 0.2$	. . . . 43.633		For $v = 1.2$	. . . . 7.2722
For $v = 0.3$	. . . . 39.089		For $v = 1.3$	. . . . 6.704
For $v = 0.4$	. . . . 21.817		For $v = 1.4$	. . . . 6.2249
For $v = 0.5$	. . . . 17.452		For $v = 1.5$	. . . . 5.8177
For $v = 0.6$	. . . . 14.544		For $v = 1.6$	. . . . 5.454
For $v = 0.7$	. . . . 12.465		For $v = 1.7$	. . . . 5.134
For $v = 0.8$	. . . . 10.908		For $v = 1.8$	. . . . 4.848
For $v = 0.9$	. . . . 9.687		For $v = 1.9$	. . . . 4.593
For $v = 1.$	. . . . 8.727		For $v = 2.$	. . . . 4.363

*Sequence of Test-Objects.*—If a complete sequence of test-objects be required, the progression should be a geometrical one.

Green<sup>2</sup> and Ewing, of St. Louis, have published a series of test-letters based upon a definite geometrical progression ( $x = \sqrt[3]{.5} = .795$  nearly). They thus obtain a scale in which the intervals are all equal. The numbers on this scale are approximately 50, 40, 32, 25, 20, 16, 12.5, 10.8, 6.25, 5. At five metres eleven different degrees of acuity can thus be noted in terms which are obtained by reducing the fractions  $\frac{5}{50}, \frac{5}{40}, \dots, \frac{5}{5}$ ,—*viz.*,  $\frac{1}{10}, \frac{1}{8}, \frac{1}{6}, \frac{1}{5}, \frac{1}{4}, \frac{2}{5}, \frac{1}{2}, \frac{5}{8}, \frac{4}{5}, 1$ ; or, in decimals, 0.1, 0.125, 0.16, 0.2, 0.25, 0.3, 0.4, 0.5, 0.63, 0.8, 1. The same series may also be extended to include greater or less degrees of visual acuity than the above.

Vierordt<sup>3</sup> has suggested that it might be better to express the visual acuity as inversely proportional to the surface of the smallest perceptible retinal image,—*i.e.*, to the tangent square of the smallest perceptible visual angle. Accordingly, instead of  $v = \frac{1}{2}, \frac{1}{4}$ , etc., we should write  $v = \frac{1}{4}, \frac{1}{16}$ , etc. Where one's aim is to note the brightness or color of the image, it seems appropriate to determine the surface by square measure; but, looking upon the visual acuity as determined by the recognizable distance which separates the two retinal images, as first proposed by Hooke in 1705, we should continue, contrary to Vierordt's proposal, to estimate the visual acuity in lineal measure, allowing the perceptibility of light and color to be reckoned in square measure. It must be remarked, however, that, as regards both lineal and square measure, the perceptibility does not alter in strictly direct proportion to the size of the retinal image,

<sup>1</sup> Schproben zur Bestimmung der Sehstärke für die Ferne, von Dr. Leopold Weiss, Heidelberg, 1895.

<sup>2</sup> Transactions of the American Ophthalmological Society, 1868.

<sup>3</sup> Archiv für Ophthalmologie, ix. 1, S. 163; *ibid.*, ix. 3, S. 219.

as the functional value of the retina diminishes from the centre to the periphery.

Visual acuity, besides depending upon the integrity of the retina, is influenced by (1) the transparency of the media; (2) the intensity of illumination; and (3) the requisite perfection of the dioptric system of the eye.

*Influence of Transparency of Media.*—Visual acuity is diminished by loss of transparency in the media of the eye. This loss of transparency may be in the inner layers of the retina, in the hyaloid membrane, in the vitreous humor, in the lens, in the pupil, in the aqueous, in Descemet's membrane, or in the cornea. Temporary lowering of the acuity may result from films of mucus, etc., lying on the surface of the cornea.

The surrounding air also is by no means always equally transparent, and for this reason  $v = \frac{6}{6}$  is not necessarily found, even in-doors, to correspond to  $v = \frac{6}{60}$ . Aqueous vapor, dust, and smoke diminish the visual acuity very considerably. Objects seen across a heated surface appear distorted, whilst those seen through a glass window appear indistinct, owing to absorption and irregular refraction of light.

*Influence of Illumination.*—The most suitable illumination for the examination of visual acuity is average daylight, or artificial light of about the same intensity. In both cases the surrounding light should be of corresponding intensity to that by which the test-objects are illuminated. Not only the absolute intensity, but also and especially the state of adaptation of the eye to light, determines the relative influence of illumination. A weak illumination is darkness to an eye which has just been exposed to strong sunlight, whilst the same illumination may appear bright to an eye that has been adapted for the dark. For complete adaptation to take place, an eye must be exposed for at least a quarter of an hour to the same intensity of illumination that is used during testing. It is necessary to avoid contrasts of illumination by which the apparent brightness is altered, although for differences of intensity which fall within the limits of ordinary daylight the acuity of vision remains almost the same. Strong illumination at first increases visual acuity, but beyond a certain degree causes after-images, dazzling, and irradiation, so that the retinal images become enlarged and confluent. On diminishing the illumination beyond a certain degree of intensity, there is a gradually resulting diminution in visual acuity.

*Effect of Refraction, Accommodation, and Glasses.*—Full visual acuity must be looked upon as that which is found after correction of any abnormality of refraction. If the test be made with the parallel lines, the influence of astigmatism may be excluded by placing the lines in the direction in which they are most distinctly seen. All that is then necessary is to determine the spherical glass which gives the best distant vision.

It is only by excluding all disturbances caused by want of trans-

parency or by abnormal refraction that a correct conclusion as to the perceptive power of the retina can be arrived at.

Giraud-Teulon has proposed to exclude all influence of refractive errors by the use of stenopæic apertures, in order to avoid the effect produced by glasses on the size of the retinal images. This plan, however, has its drawbacks, as the stenopæic apertures shut off a large amount of light, and, besides, clinically it is most desirable to combine the determination of the visual acuity with that of the refraction.

If we adhere to the rule of testing the acuity of vision at a distance, we avoid the effects of accommodation or of glasses upon near objects, and we have only to correct the refraction. Myopia and hypermetropia almost always depend upon alteration in the length of the axis of the eye, and not upon change in the refractive media. In such cases the size of the retinal image, in applying the correcting glasses, will be equal to that found in emmetropic eyes, if only the lenses be so placed as to coincide with the anterior focus of the eye.

As a rule, in making the distant vision test and in placing the glasses at one and a half centimetres' distance in front of the eye their effect on the size of the retinal image may be neglected. On the other hand, where the error of refraction depends upon abnormalities in the refractive media, the correcting glass may have a considerable effect on the size of the retinal image. This is chiefly the case with aphakia. By moving the glass away from the eye an increase of refractive power is obtained, which in the case of strong lenses is sufficient to enable an individual to focus alternately for both distant and near objects, thus supplying the want of accommodation; with the advantage, moreover, that near vision is facilitated by the increase of the size of the retinal image.

In aphakia the length of the visual axis remains unchanged; the hypermetropia is, therefore, in this case exclusively a refractive change. The second nodal point of the refractive combination of the correcting glass and the eye will advance, and the retinal image will enlarge, the stronger the correcting glass and the farther it is moved in front of the eye.

If the correction of an aphakic eye of 25.1 millimetres' length for distant vision be effected by a lens of ten diopters' strength situated ten millimetres in front of the eye, the focus of the system will be altered respectively to one hundred and eighteen, sixty-three, and forty-seven centimetres by increasing the distance between the lens and the eye to twenty, thirty, and forty millimetres.

These distances can be readily calculated by the formula for the cardinal points of the eye. The distance from the second nodal point to the retina ( $\gamma''$ ) is easily found, whilst the proportion  $\frac{\gamma''}{g''}$  gives the relative sizes of the images of the corrected aphakic and the emmetropic eye. The accompanying tables show the results of calculation for the aphakic eye:



Distance between glass and eye. ( <i>d</i> )	Distance of punctum remotum. ( <i>p</i> )	Distance between second nodal point and retina. ( $\gamma''$ )	Proportion between the distances from nodal point to retina in emmetropic and aphakic eye. $\left(\frac{g''}{\gamma''}\right)$
---	--	---	---

In aphakic eye of H. = 10 D and axis = 25.1 millimetres :

10 millimetres.	$\infty$	20.9 millimetres.	0.72
20 millimetres.	118 centimetres.	23.5 millimetres.	0.64
30 millimetres.	63 centimetres.	26.7 millimetres.	0.56
40 millimetres.	47 centimetres.	30 millimetres.	0.47

In aphakic eye of H. = 12 D and axis = 23.9 millimetres :

10 millimetres.	$\infty$	20.3 millimetres.	0.74
20 millimetres.	88 centimetres.	23.3 millimetres.	0.64
30 millimetres.	46 centimetres.	27.6 millimetres.	0.54
40 millimetres.	36 centimetres.	32.9 millimetres.	0.46

In aphakic eye of H. = 15 D and axis = 22.4 millimetres :

10 millimetres.	$\infty$	19.7 millimetres.	0.76
20 millimetres.	51 centimetres.	23.9 millimetres.	0.63
30 millimetres.	33 centimetres.	29.2 millimetres.	0.51
40 millimetres.	25 centimetres.	37.0 millimetres.	0.41

In aphakic eye of H. = 20 D and axis = 19.9 millimetres :

10 millimetres.	$\infty$	18.7 millimetres.	0.80
20 millimetres.	32 centimetres.	24.3 millimetres.	0.62
30 millimetres.	21 centimetres.	32.5 millimetres.	0.46
40 millimetres.	17 centimetres.	45.7 millimetres.	0.33

The same results are shown graphically in Figs. 1 and 2. The ordinates of the four curves give the distances of the punctum remotum from the aphakic eye. It will be seen that these change if the correcting lens, ten millimetres in front of the eye, be gradually removed farther down the nose. The upper curve represents this for a ten-diopter lens, the lower for one of twelve diopters' strength.

From these curves the following may be deduced: If a ten-diopter lens placed at a distance of ten millimetres from the aphakic eye corrects the eye for an infinite distance, its removal to twenty-five millimetres will cause the eye to see clearly at eighty-two centimetres. By slowly moving the glass, points at distances intermediate between these two limits will successively come into focus. The same removal of a twelve-diopter lens will give the limits of distinct vision from infinity up to fifty-nine centimetres, and of a fifteen-diopter lens from infinity up to thirty-nine and eight-tenths centimetres.

In Fig. 2 are shown, as abscissæ, the dioptric values of the lens which placed ten millimetres in front of the aphakic eye corrects it for distant

vision. The ordinates are (in hundredths) the corresponding values of the fraction  $\frac{g''}{r''}$ . We thus get, as in Fig. 1, straight lines which show corresponding equal increments of  $\frac{g''}{r''}$  for equal increments of diopters. The upper line shows the value of  $\frac{g''}{r''}$  for a distance of the lens from the eye of ten millimetres; those following designate the values of the same fraction for distances from twenty millimetres to forty millimetres.

From this graphic representation it may, for instance, be seen that the value of  $\frac{g''}{r''}$  with a lens of eleven diopters ten millimetres in front of the eye is 0.63, and for a lens of thirteen diopters twenty millimetres in front of the eye it is 0.53. The lines also show that for a lens of twelve and a half diopters the values of  $\frac{g''}{r''}$  will change from 0.74 to 0.636, to 0.539, and to 0.45, if successively it should occupy a position of ten, twenty, thirty, and forty millimetres in front of the eye.

In correcting astigmatism by cylindrical lenses the second nodal point of the combined system becomes displaced, and correspondingly also the size of the retinal image is different in the two principal meridians of the eye. An astigmatic individual after correction thus sees images differently from an emmetrope, and in a still more altered manner from that in which he himself would see them without the use of a correcting lens.

*Tests for Near Vision.*—By the power of accommodation the position of the second nodal point and, therefore, the size of the retinal image are altered. In an emmetropic eye focussed for distance, the second nodal point lies 14.86 millimetres in front of the retina. If the eye be accommodated for thirteen centimetres in front of it, this distance will measure 15.26 millimetres. Much greater is the alteration of this distance when in presbyopia the weakness of accommodation is supplemented by the use of lenses. The same rules as have been shown to apply to aphakia apply also here with reference to the displacement of the second nodal point, its dependence upon the strength of the glass, and its distance from the eye. Where strong lenses are required, their distance from the eye has an appreciable effect on the size of the retinal image.

Whilst for the distant test we have given the preference to isolated letters or figures, for near examination, on the contrary, reading tests are to be chosen. These are easily obtainable in the form of printed type, and, as more especially the smaller sizes are necessary, a great variety can be got within a moderate compass. By causing the patient to read, faults and inaccuracies will readily be determined, and, further, the time required to read a definite amount of print affords the opportunity of noticing the reading powers of the patient, thus providing an additional test by which to judge of improvement or deterioration in the visual function. In cases

of relative scotoma near the centre of the field of vision, and also with other disturbances, the test of facility in reading may be employed to advantage.

*Age and Vision.*—As a rule, the visual acuity remains unaltered up to the age of twenty-five years. After that time it slowly and regularly diminishes, as has been demonstrated by the result of examinations made upon a large number of individuals. In advanced life the measure of acuity is reduced to half of its original. Of course it is necessary in such examinations to exclude all pathological processes. Refraction-anomalies must also be corrected.

Cornical processes may occur which, without leaving any objective trace, produce nevertheless irregular astigmatism, which can only partially be corrected by lenses. In the interior of the eye, also, processes may occur without leaving any obvious traces. Consequently, the older the individual is, the greater is the chance that some such cause of diminished visual acuity may be present.

It would be of advantage to institute in established clinics a series of examinations on the same individuals, beginning in youth. If the examination be accurate and all concomitant circumstances be taken into consideration, the numbers available for statistics need not be numerous. Such series of observations are not yet at our disposal, but it is desirable that a beginning upon observations of this kind should be made.

With the advance of age decrease in the transparency of the media and in regularity of the refractive surfaces takes place. This is well shown in the *areus senilis* of the cornea, and in the increased reflection and coloration of the lens, which in more advanced subjects are so constant in appearance that they may almost be looked upon as physiological.

At the suggestion of Sattler, determinations of the eyesight as found in old age have been made on an elaborate scale by Boerma and Walther.<sup>1</sup> With great precision the eyes were previously examined, and, as far as possible, all that showed abnormality were excluded.

In a series of one thousand persons six hundred proved to be unfit for statistical purposes; the remaining four hundred, with seven hundred and twenty-five eyes, were used. The investigation confirmed the opinion that eyesight decreases slowly and regularly with increase of age.

For the ages of forty, fifty, sixty, seventy, and eighty years they found respectively 6.1, 5.98, 5.66, 5.21, and 4.15, as the distances at which letters of No. 6 of the author's optotypes could be recognized. Three persons from seventy-six to eighty years of age were noted as having an eyesight of more than  $\frac{5}{8}$ .

Still more favorable figures have been obtained by Cohn.<sup>2</sup> He studied a great number of persons above sixty years of age of a better social con-

<sup>1</sup> Untersuchungen über die Abnahme der Sehschärfe im Alter, Boerma und Walther, aus der Universitäts Augenklinik, Leipzig, Archiv für Ophthalmologie, xxxix. 2.

<sup>2</sup> Archiv für Ophthalmologie, xvii. 2, S. 305; xi. S. 326.

dition, and was enabled to exclude with greater precision all disturbances which were not to be included under the normal senile phenomena. Moreover, whilst Boerma and Walther made their examinations upon prisoners and convalescents, many of whom had passed indifferent lives and were addicted to the abuse of alcohol, Cohn made his studies in the healthy country of Schreiberschau. It also deserves to be taken into consideration that Cohn made his observations during clear weather and in the open air, where the pupils necessarily became narrow. The concurrence of the two circumstances narrow pupils and bright illumination may explain how Cohn seemed to find among his Schreiberschau people in old age a useful amount of accommodation. He mentions two old men, above seventy years of age, both with slight hypermetropia, who read type No.  $1\frac{1}{2}$  without lenses. This cannot very well be interpreted otherwise than by myosis and strong illumination. He stated that many individuals above seventy years under these circumstances had an eyesight of  $\frac{6}{6}$ . He concluded, however, that a great number of senile eyes would have to be examined before a definite law for the diminution of eyesight with increase of age could be established.

Very early in life the power of accommodation begins to diminish. With this diminution there is evidently associated a greater difficulty in rapid and accurate application of the accommodative power for definite distances, and, further, if astigmatism exists, there will be less rapidity in successively adjusting the vision for different meridians. In these determinations it is important to consider the rapidity of visual acuity.

After deducting the disturbing influences of changes in the refracting media, the remaining acuity of vision may represent the amount of perceptibility of the retina.

The term "visual angle" (*angulus visorius*) was originally employed by Scheiner in 1600. He spoke of two visual angles, one formed by two directional external lines from the observed object, the other drawn through the point of rotation and formed by the two lines of fixation by which, on movement of the eye, two points are successively viewed.

The determination of the visual angle under which two points can be separately distinguished was first made in astronomical research.

Hooke (1705) established the fact that two stars are in no case separately visible under a smaller visual angle than one-half minute, and that for most eyes an angle of at least one minute is required for their recognition. Stars, however, owing to their feeble luminosity and to their different brightnesses, are not suitable objects for such observations. Hooke's statements have been repeated from a physiological stand-point under different conditions by Hueck with black points on white paper; by Aubert with squares black on white or white on black; by Job Mayer, Weber, and Bergmann with parallel lines; and by Helmholtz with black metal wires looked at against the sky. The results of these experiments are far from being uniform. This is partly owing to observational differences,

but is mainly dependent upon dissimilarity in the eyes tested, where slight anomalies of refraction evidently had been left uncorrected.

*Review of Different Test-Types.*—For clinical examination reading-tests have been used. Alfred Smece<sup>1</sup> gives for this object several lines of differently-sized print. It is less generally known that eleven years previously (1843) there was published by KÜCHLER, of Darmstadt, “Die Schriftnummerprobe für Gesichtsleidende.”<sup>2</sup> In 1855 Stellwag von Carion added reading types to his book.<sup>3</sup>

As a practical test, the *Schriftscalen* of Jaeger have found favor. They were published in Vienna in 1854, and consisted of twenty different sizes of reading type to be used for testing at short distances. They were, however, not accompanied by any indication as to the distance at which each type should be seen, nor was there any regular gradation in the sizes of type employed.

At the instance of v. Graefe, the author undertook an investigation with the object of determining how the visual acuity might be tested in a more systematic manner. As the result of a series of experiments and trials, in 1862 the first edition of the author’s test-types appeared. These differ in many respects from Jaeger’s *Schriftscalen*. In the first place, they were meant to be used at a distance, and consisted principally of a series of separate letters and of correspondingly distinct figures. Additional types for reading purposes were added. The letters and figures were made square. The lines and interspaces as far as possible were alike, and amounted to one-fifth of the height of the letters. The construction of the letters was based upon that of the three parallel lines with equal width of lines and interspaces. The simplest figures consisted of differently directed series of three lines, of which the length equalled five times the thickness of each line. For further differentiation, these three short lines were joined together at one end by an equally thick line. As this served to make the figures less distinguishable, the middle line was shortened by one-fifth of its length. For the letters of the alphabet the so-called Egyptian paragon types were chosen. In these each stroke is ended by a transverse stroke. The less readily distinguishable letters of the alphabet were rejected. Over each series of letters of the same size a number was placed indicating the distance (in feet or metres) at which the letters subtended an angle of five minutes. In calculating the size, the arc and not the tangent was taken.

The *Schproben* of Schweigger consist of a large collection of reading-tests in German and Latin characters, made in the French, German, and English languages. In addition there are tables of single letters, approximately corresponding to the author’s optotypes. It must be mentioned

<sup>1</sup> *The Eye in Health and Disease*, 1854, p. 70.

<sup>2</sup> See Schirmer’s *Lehre von den Refractions- und Accommodations-Störungen des Auges*, S. 46, Berlin, 1866.

<sup>3</sup> *Accommodations-Fehler des Auges*, 1855.

that Schweigger recommends that in the fraction  $\frac{d}{D}$  another value should be given to  $D$ , in order to exclude the influence of the instability of the illumination at different times. "Sometimes," he says, "we may find an apparent improvement in patients, which in reality must be due to an improvement in the weather." He proposes to value  $D$  as the distance at which the test-objects are discerned by himself. It is clear, however, that he herewith introduces another factor, the stability of which is not absolutely beyond doubt.

Boettcher<sup>1</sup> has introduced a series of what he terms geometrical test-types. In addition to German (Gothic) reading tests, these contain sets of square figures with a notification of the distance at which the figures of each size may be recognized and counted by a normal eye. The objection to these tests is that it is not stated what is assumed to be the normal standard of vision.

Since 1869, Burchardt<sup>2</sup> has recommended, for the determination of visual acuteness, sets of dots, the diameters of which are, as a rule, equal to the reciprocals of the distances at which they should be counted. They are intended for those who are unable to read or who are unfamiliar with Latin type. They correspond in shape and arrangement with those that were first recommended by Striedingen.<sup>3</sup>

To meet the wishes of Deputy Inspector-General Longmore, similar disks were included in the second edition of Snellen's optotypes (1862), which was printed for the use of the Army Medical School in England. For the sake of comparison these disks were printed both in black on white and in white on black. Though the dimensions and arrangement in five-fold squares were in correspondence with the letters, they proved to be much less distinguishable, and, indeed, hardly comparable to the standard letters and figures. They have been omitted in later editions and replaced by series of parallel lines.

The author acknowledges the suitability of Burchardt's dots for some comparative experiments, but for clinical use, where the quickest means of noting the principal functions of sight are required, preference must be given to letters and corresponding figures.

Points and dots are of value in gauging the distinguishing power of small retinal areas. Parallel lines permit of the determination of the same functional activity over more extended portions of the retina. Complicated figures provide for testing the more complex retinal functions; something more nearly approaching to reading, which possesses a higher degree of psychical signification. This is well expressed by Burchardt :

<sup>1</sup> Geometrische Schproben zur Bestimmung der Sehschärfe bei Functionsprüfungen des Auges, mit besonderer Berücksichtigung der Untersuchung Militärpflichtiger, von Dr. Boettcher, Berlin, 1870, Verlag von Hermann Peters.

<sup>2</sup> Berliner Klinische Wochenschrift, xlviii.

<sup>3</sup> Statistical Sanitary and Medical Reports, London, 1860.

“The recognition of letters is not a simple and direct function of sight; it involves a conclusion, an act of thought, which is based upon uniting the retinal images of the separate parts of each letter.”

According to the requirements which are desired for the determination of vision, it becomes necessary to choose as tests, first, either dots or parallel lines, then figures and letters, terminating the examination with reading tests. The last edition of Burchardt contains, in addition to the disks, a set of reading types, which, however, do not occupy a prominent place.

A still more elementary visual act than the distinguishing of two separate points is the recognition of a single point or disk. Guillery<sup>1</sup> has recommended this as the simplest means of determining the acuity of vision, and gives a series of disks of different sizes, each arranged in a separate square, the requirement of the test being that the patient has to mention in what part of the square the disk lies. The distinctness and sharpness of perception will here increase with the size of the image, and, if the intensity of illumination diminishes or if the visual acuity decreases, a retinal image of greater dimensions will be required,—that is, the perception will be clearer in proportion to the number of nerve-elements involved in the retinal image.

There is no question here of distance, and certainly in this case Vierordt's principle,<sup>2</sup> that not the diameter of the image but its square is to be taken, may be considered. Just as with the color and brightness of a surface, so with the distinction of one single disk, it is more a photoptrical than an eidoptrical function: it is the brightness and not the shape that has here to be considered. The disk may be indefinitely small if only the light be sufficiently strong.


The observation of one disk is a retinal function different from and more restricted than the distinction of two points, and the result of the one does not directly lead to a conclusion as to the other. In observing a row of disks at gradually increasing distances—*i.e.*, under a decreasing visual angle—the distinguishability of the lineal distances of the separate figures sooner reaches the limits of perceptibility than does that of the surface. The row of disks first shows a beaded appearance, and at a greater distance is seen a diffused line. It is only under a much smaller visual angle that the image totally vanishes.

The greater influence of differences of illumination which affects Guillery's method of measuring the acuteness of vision has made it less acceptable for clinical employment. His tests have been executed with great accuracy, yet the distances from the disks to the edges of each square are unequal. Some of them are at the same or even a smaller distance from the edge of the square than the diameter of a disk, and these merge into the edge before they become invisible. Another objection for clinical use

<sup>1</sup> Sehproben zur Bestimmung der Sehschärfe, von Dr. Guillery, Stabarzt in Köln, 1891.

<sup>2</sup> Archiv für Ophthalmologie, ix. 1, S. 163, iii. S. 229.

is that uneducated people have great difficulty in noticing the limits between invisibility and only slight perception, and it is difficult to avoid the effects of imagination. Guillery himself makes the observation that the relation between his tests and the letter-tests is not equal for larger and for smaller visual angles.

For the examination of the vision of school-children Cohn has arranged thirty-six of the author's  figures in such a way that they form six rows of six figures each, from left to right and up and down. This allows for four different orders of succession of the figures, according to the position in which the square board is hung. This board is recommended by Cohn as a means of judging the amount of illumination of a room. He has also published "transparent test-types."<sup>1</sup> These are similar to the ordinary test-types, but are printed on transparent paper. They are intended to be placed between two glass panes and hung against the window, so as to be seen by transmitted light. This arrangement admits also of the types being seen reflected from a mirror, as for this purpose all that is required is to turn the back surface to the front. In a room which is sufficiently lighted, this may prove of some advantage, but, on the other hand, placing a patient with the face opposite to the window, or even to a mirror, may sometimes be a disadvantage.

Pflüger's Sehproben, which are dedicated to the present author, are similar to the original optotypes, except that the choice of letters and figures is different. Letters of less distinctness are employed by him, as he has been guided by the desire to choose symmetrical letters the reflected images of which are the same as their direct images, in order that they may be used with a mirror in the same way as Cohn's transparent board.

Oliver<sup>2</sup> has devised a series of test-letters made in metrical progression. These contain a series of letters which are uniform with the author's paragon type. The smaller letters are phototyped, and each letter occupies a square area included in a five-minute angle for both height and breadth. The breadth of each line subtends an angle of one minute at the appropriate distance, and each interspace subtends the same or a greater angle. In order to get easy fractions the following numbers have been chosen: 5,  $7\frac{1}{2}$ , 10, 15, 20, 25, 30, 35, 40, 45, 50, giving by reduction the following fractions:  $1, \frac{2}{3}, \frac{1}{2}, \frac{1}{3}, \frac{1}{4}, \frac{1}{5}, \frac{1}{6}, \frac{1}{7}, \frac{1}{8}, \frac{1}{9}, \frac{1}{10}$ . The printing of these types has been done with great care.

Nieden<sup>3</sup> and Albrand<sup>4</sup> have each brought out a series of test-types. Both of these begin with the problematical statement that the tests are intended to supply what they call "a much-needed desideratum." In contradiction to this statement, however, may be taken Albrand's remark,

<sup>1</sup> Professor Dr. Hermann Cohn, Transparent Test-types, F. Deuticke, Vienna, 1894.

<sup>2</sup> A New Series of Metrical Test-Letters, Transactions of the American Ophthalmological Society, 1885; Archives of Ophthalmology, 1893.

<sup>3</sup> A. Niden, Bochum, Schrifttafeln zur Bestimmung der Sehstärke für die Ferne.

<sup>4</sup> Sehproben, zusammengesetzt von Dr. Albrand.



“On account of the good execution and the manifold varieties and arrangement of a great many former test-types which have been generally adopted, it seems to me superfluous, on the whole, to propose any substantial alterations.”

In addition to these, a long series of modifications of different kinds have been published, of some of which it will suffice to mention the titles alone: Galezowski, “Echelles typographiques et chromatiques,” Paris, 1894; L. de Wecker, “Echelle métrique pour mesurer l’acuité visuelle,” Paris, 1877; and “Einheitliche Sehproben zur Untersuchung der Sehschärfe in der Ferne und in der Nähe, von Dr. Adolf Steiger,” Bern, 1892.

Both de Wecker and Steiger recommend boards having a series of  $\sqcup$ -like figures printed upon them. As the distance between the lines in all of these figures is three times the breadth of the lines themselves, they are much more easily recognized than the three parallel lines.

Lotz<sup>1</sup> has brought out a series of types which consist of simple figures of different shapes. They cannot, however, be compared with the standard lines.

Weiss<sup>2</sup> has arranged a series of types. These correspond with the original optotypes, except that this series is more complete. This is done in order to facilitate the determination of equal intervals of visual acuity without altering the distance at which the test is made. Weiss uses intervals of a tenth, although he disapproves of the method of denoting the acuity of vision in decimal fractions. He concludes his paper on the determination of vision as follows: “I agree with those who do not express the result of the visual test in decimal fractions, but who make the numerator refer to the distance at which the tests have been made, and the denominator to the distance at which the test-objects subtend the visual angle of five minutes. This notation gives information as to the way in which the test has been conducted.”

Wolffberg’s tests<sup>3</sup> contain, in addition to reading types, ingenious figures for children, and boards with sets of letters of twelve different sizes. The numbers are 50, 30, 20, 15, 12, 10, 8, 6, 5, 4, 3, 2. The letters are of the non-complicated antique shape, and are easier to recognize than the three parallel lines. A commendable arrangement is that he gives several sets of these types containing only one letter of each size. This makes the boards, which are printed on linen, more portable, and, what is of more value, the small number of letters is named by the patient in much less

<sup>1</sup> A. Lotz, Bâle, 1889, Echelles internationales à signes simplifiés pour l’examen de la force visuelle centrale chez les illettrés et les enfants, d’après le principe de Snellen,

$$v = \frac{d}{D}$$

<sup>2</sup> Leopold Weiss, Heidelberg, 1895, Sehproben-Tafeln zur Bestimmung der Sehschärfe für die Ferne.

<sup>3</sup> Hr. Dr. Wolffberg’s Sehschärfeproben, Breslau, 1892 (gesetzlich geschützt).

time than can be done where the series is more extended, quickness being of great importance in any clinic.

Straub's "proefletters" form the antithesis of Wolffberg's concise system. This series is arranged especially for military examinations, and consists of three maps, each with a large number of letters and figures, amounting altogether to four hundred and twenty. They provide well for the requirement that the person examined shall not learn the letters by heart. On the other hand, they have the disadvantage that the examiner cannot do so either; cannot control the accuracy with which the letters are named without himself looking at them. This is a drawback especially if he wishes at the same time to test the refraction by holding different glasses in front of the eye.

Jaeger's *Schriftscaln* consisted of a very complete set of reading tests printed in several languages. Unfortunately, Jaeger always refused my request that he should indicate for each number the distance at which the prints could be seen under a visual angle of five minutes. This want has now been supplied by Fuchs<sup>1</sup> in his modified edition of Jaeger's *Schriftscaln*.

Nicati<sup>2</sup> gives a set of five-fold square letters according to the expression  $v = \frac{d}{D}$ , to be seen at a distance of three and a half metres. The distance

of three and a half metres has been chosen because each line which subtends an angle of one minute at that distance is very nearly one millimetre in breadth. Besides these he gives a special series of letters which are based on an altogether different value and are intended to express what he calls "physiological vision." In opposition to the physical expression of vision as inversely proportional to the visual angle, he designates physiological vision as a series of values based upon a system which is in conformity with Fechner's psycho-physical law. His values representing physiological vision are brought into accord with the increase which takes place in visual acuity with increasing intensity of illumination. Board No. 6 contains a series of types for each set of which there is noted the minimum amount of light which the normal eye requires in order to read them at the indicated distance. The types increase in geometrical progression,  $L = 1, \frac{1}{2}, \frac{1}{4}, \frac{1}{8}, \dots$ , while at the same time his proposed corresponding values of physiological vision represent an arithmetical progression: 1, 0.9, 0.8, 0.7, . . . . .

If an undoubted direct relation between the geometrical increase of light and the arithmetical values of Nicati's scale of physiological vision can be stated, his test will permit of the one being deduced from the other. Indeed, he proposes to apply his scale of physiological vision to photometric purposes. From the amount of physiological vision he infers the relative strength of illumination, always, however, on condition that the

<sup>1</sup> Leseproben für die Nähe. Jaeger's *Schriftscaln* modificirt von Prof. Dr. E. Fuchs, Wien, 1895.

<sup>2</sup> W. Nicati, *Echelles visuelles et leurs applications*, Paris, 1894.

observing eye be normal, emmetropic, and adapted for the given amount of light. He observes that the use of one eye requires double the illumination that is necessary for the use of both eyes,—*e.g.*, seeing with both eyes is equal, from this physiological point of view, to seeing with one eye under a double intensity of illumination. His assertions seem still to call for experimental confirmation. Such researches are, however, not unattended with difficulty. The accurate measure of illumination as well as that of the limits of distinctness requires many precautions and great care in order to avoid obtaining erroneous results.



# MYDRIATICS AND MYOTICS.

BY HERMAN SNELLEN, JR., M.D.,

Ophthalmic Surgeon to the Netherlands Hospital, Utrecht, Holland.

---

CERTAIN substances, especially some alkaloids derived from the Solanaceæ, have the power of producing a dilatation of the pupil (*mydriasis*), and hence are termed *mydriatics*. At the same time they act upon the ciliary body, diminishing and, when applied in sufficient strength, completely paralyzing the power of accommodation, thus rendering the eye for some time unalterably focussed for the farthest point. If there has been permanent tension of accommodation, it gives way under the influence of the mydriatic, and the farthest point of distinct vision moves farther from the eye than it would in simple relaxation without the aid of such substances.<sup>1</sup>

Other materials,—for instance, *eserine* and *pilocarpine*,—when applied to the eye, have the power of diminishing the size of the pupil (*i.e.*, of producing *myosis*), and hence receive the name of *myotics*. They also act upon the ciliary muscles, producing more or less spasm of the accommodation. Unlike that of the mydriatics, the action of the myotics does not render the pupil immobile. The influence of light on the size of the pupil does not cease altogether; neither is the accommodative power paralyzed. On the contrary, during the period of diminution of the action of the myotic, the range of accommodation is absolutely increased, the influence on the near point being greater at that time than on the far point.<sup>2</sup>

The usual form of application of mydriatics and myotics is into the conjunctival sac in solution, in ointment, or in gelatin wafers that are impregnated with the drug. Most of these drugs being poisonous, great care should be taken not to apply them too freely or in too strong solution. If it is necessary to use a strong solution, it is advisable to close the canaliculi by pressure, so as to prevent the drug from running down with the tears into the nose and thence into the mucous membranes of the upper intestinal tract, where it can be more rapidly absorbed into the circulatory system.

All mydriatics act in the same way. They differ only in the time and in the strength of solution which are required to produce the same result. As an example we will choose *atropine*, an alkaloid which is derived from

---

<sup>1</sup> Donders, *Anomalies of Accommodation and Refraction of the Eye*, p. 587.

<sup>2</sup> Donders, *loc. cit.*, p. 613.

*Atropa Belladonna*, and which has been thoroughly investigated by Donders and some of his scholars. It is the oldest mydriatic known, and for a long time was the only reliable one. The action of belladonna on the pupil is spoken of by van Swieten.<sup>1</sup> Wells<sup>2</sup> has studied its influence upon the accommodation. The chemical substance to which these actions are due was not known until 1833, when Mein, Geiger, and Hesse determined it to be an alkaloid, which they named *atropinum*.

Atropine crystallizes from alcohol in the form of needles which are soluble in three hundred parts of water. With acids it forms salts that are more soluble, and therefore are more suitable for application. Among these salts the sulphate is the one that is most commonly employed.

According to Donders, one drop of a solution of one part of sulphate of atropine in one hundred and twenty parts of water is sufficient to produce the full effect.

Jaarsma<sup>3</sup> has found that one drop of a solution of one to twelve hundred paralyzed the accommodation for twenty-four hours. According to the same author, the weakest solution that is able to produce mydriasis is one to eighty thousand. Its full action takes place one hour after the instillation of the drug, and lasts twenty-four hours. It must be observed, however, that with these minimal doses we refer only to normal eyes. In case of inflammation or spasm of accommodation a repeated instillation of a much stronger solution often proves to be insufficient, not to mention the presence of synechiæ, in which case full dilatation of the pupil is often impossible.

Again, its influence differs in various individuals, the young, upon account of the thinness of their eye-walls, being more quickly affected than the old. In some animals—for instance, dogs and cats—its action on the pupil is about the same as in the case of man. The action is less marked in rabbits, very slight in birds, just perceptible in frogs, and scarcely or not at all noticeable in fishes.

The mode of action of atropine has been investigated by Donders and de Ruyter. Independently of their researches, von Graefe arrived at the same conclusion that they did,—viz., that atropine acts on the eye itself, without interference with the centre of innervation.

The following experiments<sup>4</sup> have established beyond doubt that atropine applied to the conjunctival sac passes into the aqueous humor, and that the result is produced by the direct action of the drug: first, removal of the outer layers of the cornea hastens the action; second, the application, confined to the cornea, in the eyes of frogs after excision of the heart (so as to stop the circulation), after decapitation, after removal of the brain and the spinal cord, and even after complete isolation of the eyes, produces

---

<sup>1</sup> Van Swieten, Comment. in Boerhaviæ Aphorismos, t. iii.

<sup>2</sup> Wells, Philosophical Transactions, 1811, p. 378.

<sup>3</sup> Jaarsma, Thesis, Leyden, 1880.

<sup>4</sup> Donders, loc. cit., p. 589.

distinct dilatation of the pupil in a few minutes; third, a trace of an extremely dilute solution introduced into the anterior chamber produces pupillary dilatation in rabbits. Finally, after repeated instillations into the conjunctival sac of a rabbit, the aqueous humor can be evacuated and instilled upon the cornea of another rabbit, producing considerable dilatation of the second animal's pupil. In a similar experiment von Graefe injected the aqueous humor into the anterior chamber of the animal.

Donders would not admit that atropine acted directly upon the muscular fibre-cells, as he believed that there was a muscular dilatator. He thought that in such a case atropine acted upon the dilatator muscle in the same way as it does on the sphincter. He therefore inferred that atropine acts either on the nerve-fibres or on the ganglionic cells in the eye.

The action of atropine, however, is not quite independent of central innervation. If division of the sympathetic nerve has previously taken place, the pupil on the same side is not so fully dilated by atropine as that on the undivided opposite side. Moreover, paralysis and division of the trigeminal nerve have no influence upon the action of the drug.

On the other hand, in case of complete paralysis of the oculo-motor nerve, the size of the pupil is considerably increased when atropine is used.<sup>1</sup> After removal of this nerve an additional dilatation occurs when atropine is employed. To explain this, Donders has assumed that in addition to the paralyzant action on the oculo-motor nerve there is a stimulating action on the sympathetic.

In cases of atropine dilatation, an additional enlargement of the pupil can be produced by the instillation of cocaine. This is accomplished by contraction of the blood-vessels.<sup>2</sup> On the other hand, dilatation of the pupil produced by atropine is greatly diminished if the aqueous humor is allowed to escape through a puncture of the cornea. This effect is mechanically obtained by a diminution of the intra-ocular tension and a filling of the blood-vessels of the iris.

According to Donders, the action of atropine begins within fifteen minutes after the instillation of one drop of a solution of one part of sulphate of atropine to one hundred and twenty parts of water (four grains to the fluidounce). The mydriasis is the first obvious result. The diminution of the accommodation begins later. Complete accommodative paralysis occurs much later. The mydriasis attains its maximum in the course of from twenty to twenty-five minutes, the loss of accommodation at that time being hardly noticeable. Immediately following this the accommodative power rapidly disappears. Subsequently it proceeds slowly, attaining its maximum loss about one hundred minutes after the instillation. At this time the nearest point of accommodation coincides with the farthest point, and therefore the accommodative loss is complete. Total paralysis lasts

---

<sup>1</sup> Ruete, *Klinische Beiträge*, Braunschweig, 1843.

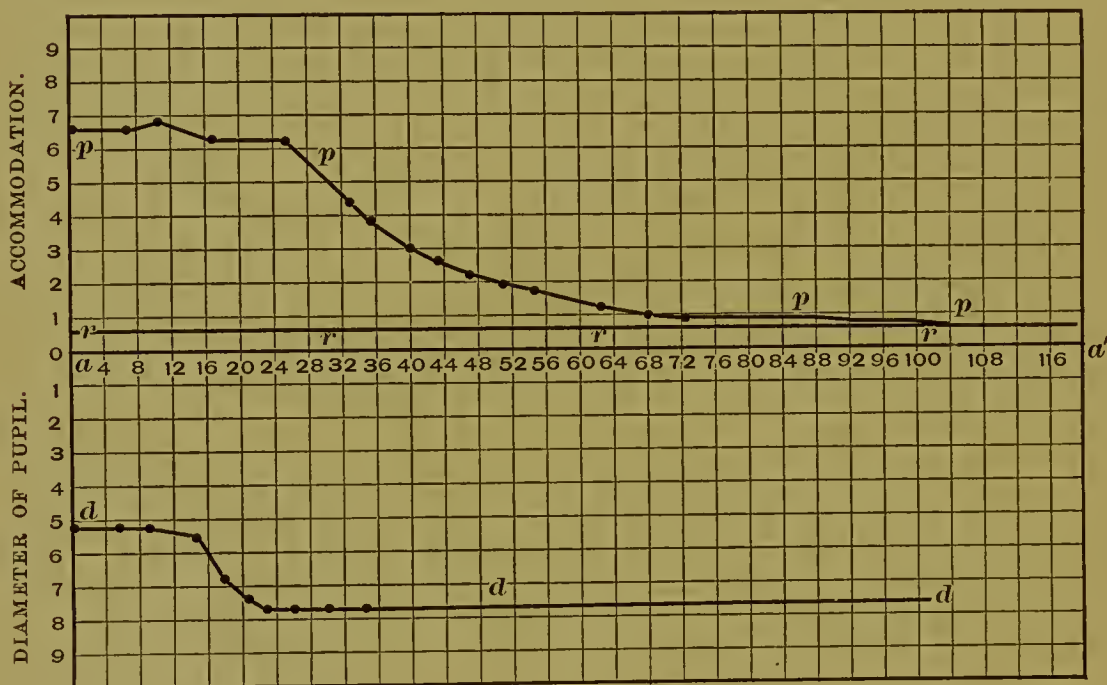
<sup>2</sup> Fuchs, *Lehrbuch der Augenheilkunde*, 1889, S. 285.

forty-two hours. After this the pupil becomes somewhat smaller, and a slight amount of accommodation returns. At first the power of accommodation increases rapidly until the fourth day, but it is not perfectly restored until after the eleventh day.

The course of the dilatation of the pupil and the degree of loss of accommodation are more clearly shown by the following curves, as given by Donders and adapted to the metrical system by Landolt.<sup>1</sup>

The dilatation is represented by the line *ddd* in the lower portion of Fig. 1. On the horizontal line *aa'* the minutes are indicated after the instillation, which took place at 0. The lengths of the downward ordinates give the diameters of the pupil in millimetres. The pupil was accurately

FIG. 1.



measured at short intervals, with perfectly equal illumination of the eye, the other eye being closed. In the upper portion of the figure the influence of the drug on the accommodation is represented. The curve *pppp* indicates the course of the near point (*punctum proximum*), and the curve *rrrr* that of the far point (*punctum remotum*). The figures at the left above zero stand for dipters.

Fig. 2, in which the horizontal line marks in days the total duration of the change of the pupil and of the accommodation, gives the diameters of the pupil in the lower portion and the course of the *punctum proximum* (*pppp*) and of the *punctum remotum* (*rrrr*) in the upper portion.

The curve *rrrr* being above the zero line shows that the person upon whom these investigations were made was slightly myopic. It shows scarcely any curvature, as is usually the case in myopic and emmetropic eyes. In hypermetropic eyes it principally shows that the far point moves from

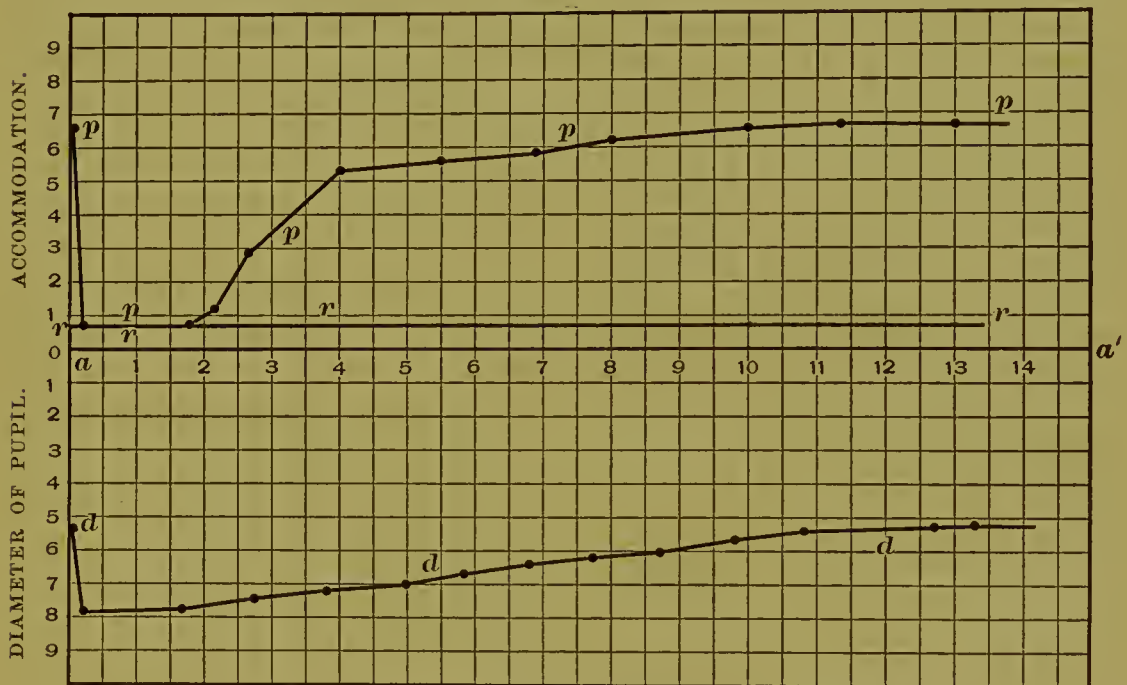
<sup>1</sup> *Traité complet d'ophtalmologie*, de Wecker et Landolt, t. iii.



the eye in proportion as the latent hypermetropia becomes manifest. The line *pppp* constantly moves from the eye, beginning from twelve to eighteen minutes after the instillation, till, at the end of one hundred minutes, *p* coincides with *r*; and, therefore, the range of accommodation equals zero.

During these experiments, on the third and succeeding days, when the accommodation began to return, but was not completely restored, Donders observed that the relative range of accommodation was similar to that of myopes, and that with a moderate convergence a comparatively small amount of accommodation could be obtained, objects at the same time appearing to be much smaller (*micropsia*<sup>1</sup>). The reason for this was that a greater effort of accommodation was required,<sup>2</sup> causing the patient to

FIG. 2.



imagine that objects were nearer, and, as the visual angle had not become greater, they were supposed to be smaller.

Objects also appear more strongly illuminated to the atropinized eye than to the fellow-eye. This effect can be best seen by placing a prism before one eye, so as to obtain double images. Again, in consequence of reflex action, the pupil of the eye not subjected to instillation of the drug becomes narrower than ordinary.

Visual disturbance differs according to the refraction of the eye. On hypermetropes the drug has the most unpleasant effect, as such subjects

<sup>1</sup> Donders, Ned. Lancet, 1851, p 607.

<sup>2</sup> H. Snellen and Redingius have found that it is not the effort of accommodation by which we judge of distance, but the convergence, which is to a certain degree associated with the accommodation. Micropsia can also be produced by putting prisms before the eye, in which case only a greater effort of accommodation is required, whereas the accommodation remains unaltered. (Verslag Ned. Gasthuis v. Ooglijders, 1895.)

cannot see distinctly at a distance nor close at hand without the aid of convex lenses. Myopes can distinguish less at a distance than usual, according to the dilatation of the pupil, but they complain less, as they can read as well as before the instillation. Emmetropes can see at a distance, but require convex glasses for near work.

Any mydriatic solution—for example, atropine—instilled into the conjunctival sac is carried away with the tears into the nasal cavity and thence to the mucous membranes of the upper portion of the digestive tract. In this way, especially after prolonged application, it may produce general disturbances, which sometimes assume a most alarming character, and may even cause the death of the patient. (Kugel.) The symptoms of general intoxication are dry throat, hurried pulse, giddiness, and weakness in the lower extremities, followed by general prostration. In order to avoid these, it is well to close the canaliculi by pressure of the finger, or to hold the patient's head on one side, so as to prevent the solution from running down with the tears into the nose during the time of instillation. The use of too strong solutions should also be avoided; but even instillations of weaker ones (0.1 to 0.4 per cent.) are said to be sometimes sufficient to provoke unpleasant complications. For the treatment of this form of intoxication, subcutaneous injections of morphine (0.01 to 0.03 gramme) are recommended. (Kugel, Hedler, Beauvais.) Pilocarpine (0.02 gramme)<sup>1</sup> has also been employed for the same purpose.

One of the inconveniences of atropine which may occur, even after but a few instillations of the drug, is an affection of the conjunctiva known by the name of *atropinism*. The condition has been attributed to impurity of the drug, to its acid or alkaline reaction, and to micro-organisms growing in the solution. Whatever the cause may be, it is advisable to add some boric acid to the solution, to use fresh solutions, and to ascertain by testing with litmus-paper that the drug is neutral. If atropinism has once occurred, the drug can never be borne. In such case extract of belladonna or some other mydriatic should be substituted. Landolt<sup>2</sup> advises the use of salicylate of atropine, because it keeps longer unchanged than the sulphate. Petorelli<sup>3</sup> recommends the employment of nitro-atropine.

In Utrecht the writer uses atropine in solution of one-half per cent., with the addition of boric acid. With this he has never met with the least general disturbance or irritation of the conjunctiva. If a very strong action is required, a one per cent. solution can be employed. In most instances repeated instillations of the half per cent. strength are preferable.

In normal eyes atropine hardly, if ever, affects the intra-ocular tension. In glaucomatous ones it may produce severe attacks of glaucoma.<sup>4</sup> Great care, therefore, should be taken not to employ atropine too freely in eyes

<sup>1</sup> Juhash, *Klin. Monatsbl.*, 1882, S. 82.

<sup>2</sup> Landolt, *loc. cit.*

<sup>3</sup> Petorelli, *Compte-rendu du congrès internat. de Milan*, 1881.

<sup>4</sup> Schumann, *Ueber den Mechanismus der Accommodation*, Dresden, 1868.

that are predisposed to glaucoma, as in old people with shallow anterior chambers. If in such cases a dilatation of the pupil is required for examination purposes, it is preferable to use a derivative of atropine,—viz., homatropine,—the effect of which lasts a much shorter time and is easily overcome by myotics.

*Homatropine* is obtained as an oleaginous liquid by the action of hydrochloric acid on the cyanate of tropine. Radenburg has succeeded in making the same substance synthetically. With hydrobromic acid the drug forms a readily crystallizable salt, which is the only one that is used in ophthalmic practice. Its effect on the pupil and on the accommodation is similar to that of atropine, except that it manifests itself more promptly and disappears more quickly. The drug, therefore, has a great advantage over atropine in those cases in which a dilatation of the pupil is wanted for examining the crystalline lens or the fundus,<sup>1</sup> or in which the accommodation momentarily has to be put at rest for testing refraction.<sup>2</sup>

Tweedy, Schaefer, and Goetz, who have investigated the action of this drug, agree that one drop of a solution of one to one hundred and twenty causes full dilatation of the pupil and complete paralysis of the accommodation, which disappears entirely within twenty-four hours, whereas the effect of a one-half per cent. solution of atropine lasts at least seven days. Patients can bear homatropine very well, and there is no serious danger of constitutional disturbance. The drug is generally employed in a one per cent. solution, one drop of which in most cases gives the full effect. In nearly all instances, even if there is strong tension of accommodation, three instillations of the above solution at intervals of five to ten minutes will produce a complete paralysis of the accommodation in twenty minutes after the last instillation. To obtain the same result, Sehell used a three per cent. solution.

*Daturine* is an alkaloid found by Geiger and Hesse in the leaves and seeds of *Datura Stramonium*. Jaarsma<sup>3</sup> has investigated its action, and has found that the weakest solution of the sulphate capable of dilating the pupil was one to one hundred and sixty thousand. The effect lasted about twenty-four hours. The accommodation became paralyzed after instillation of a solution of one to two thousand, and remained so for twenty-four hours. In all other respects it acted like atropine, and, in fact, it has been found to be identical with that drug.

*Duboisine*, extracted by Gerard and Petit from *Duboisia myoporoides*, is a most powerful mydriatic. It acts much more energetically and promptly than atropine, but its effect disappears somewhat sooner. Jaarsma<sup>4</sup> found that an extremely diluted solution of sulphate of duboisine (one in one million two hundred thousand) produced mydriasis in

<sup>1</sup> Oliver, American Journal of the Medical Sciences, July, 1881.

<sup>2</sup> Risley, Transactions of the Amer. Ophth. Society, 1881.

<sup>3</sup> Jaarsma, loc. cit.

<sup>4</sup> Jaarsma, loc. cit.

seventy-five minutes. A solution of one to three thousand paralyzed the accommodation for twenty-four hours.

Seely,<sup>1</sup> using a one to one hundred and twenty solution, saw its effect occur in from four to seven minutes. The eye bore the duboisine well, but the drug gave rise to general disturbances. On this account he recommends the use of weaker solutions.

Vierling<sup>2</sup> states that the action of duboisine is much more prompt than that of other mydriatics. The sulphate is mostly used in a solution of one to two hundred and fifty (two grains to the ounce). Instillations often produce smarting, but do not cause such severe disturbances of the conjunctiva as atropine sometimes does. On the other hand, the drug is more apt to give rise to general disturbances, and therefore has no great advantages over atropine.

*Hyoseyamine*, the alkaloid of *Hyoscyamus niger*, was obtained by Geiger and Hesse in 1833. *Hyoscine* seems to be isomeric with it, only that it differs from it in this respect, that the double chloride which it forms with gold is less soluble. Risley,<sup>3</sup> experimenting with the sulphate of hyoseyamine, found that one drop of a solution of one to three hundred paralyzes the accommodation during seventy-seven to one hundred hours. He thinks it preferable to duboisine, as being less dangerous as regards general symptoms, and better than atropine, because of its more prompt action.

Emmert found that the hydrochlorate of hyoscine prepared by Merck acts more energetically than atropine or even than duboisine, a solution of one to one thousand being sufficient to paralyze the accommodative functions. He also thinks that it is less injurious to the conjunctiva and to the general system. On this point, however, Hirschberg<sup>4</sup> and Oliver<sup>5</sup> do not agree with him. Michel also advises caution with the drug.

*Scopolamine*, the alkaloid of *Scopolia atropoides*, introduced into ophthalmology by Raehlman, is, according to Schmidt<sup>6</sup> and Merck,<sup>7</sup> considered to be identical with hyoscine. Raehlman<sup>8</sup> maintains that the drug is different, and that it has not the ill effects of hyoscine. Harvey Smith<sup>9</sup> states that scopolamine, even in a one-fifth to one-tenth per cent. solution, produces toxic effects. It is advisable, however, not to use it too freely, especially in children. Weaker solutions (less than one-half per cent.) do not appear to be so dangerous, and are quite efficient. According to Koenigstein, even a solution of one to one thousand gives the full effect. The hydrobromic salt seems to be preferable to the hydrochloric, and is em-

<sup>1</sup> Seely, Archiv f. Augenh., 1879, viii. S. 247.

<sup>2</sup> Vierling, Deutsehmann's Beiträge, xiii., 1894.

<sup>3</sup> Risley, Trans. Amer. Ophth. Soc., December, 1891.

<sup>4</sup> Hirschberg, Centralblatt f. prakt. Augenheilk., 1881.

<sup>5</sup> Oliver, Amer. Journal of the Medical Sciences, 1882.

<sup>6</sup> Schmidt, Arch. d. Pharm., 1894.

<sup>7</sup> Merck, Bericht über das Jahr 1894.

<sup>8</sup> Raehlman, Monatsbl. f. Augenheilk., 1893, S. 59.

<sup>9</sup> Harvey Smith, New York Medical Journal, July, 1894.

ployed in solutions of one-tenth to one-fifth per cent., which are equal in action to one-half and one per cent. solutions of atropine.<sup>1</sup>

*Ephedrin*, the alkaloid of *Ephedra vulgaris*, is a very weak mydriatic. Kinnozuta Miura (Tokio) found that a ten per cent. solution of the hydrochloric salt produced mydriasis in from forty to sixty minutes without affecting the ciliary muscles. Geppert discovered that a combination of ephedrin with a very weak solution of homatropine has a much greater effect on the size of the pupil than either of the drugs used separately. The mydriasis lasts only a short time, and the accommodation does not become paralyzed. This combination, therefore, has great advantages in those cases where only a temporary dilatation of the pupil is required for examining the media and the periphery of the fundus.

*Mydrin*, as sold by Merck,<sup>2</sup> is composed of one part of homatropine and one hundred parts of ephedrin. Its action has been studied by Groenouw.<sup>3</sup> According to this author, a ten per cent. solution of mydrin produces dilatation of the pupil in eight minutes. The pupil attains its maximum size in about thirty minutes. At this period the size of the pupil is between four and seven millimetres, which in most cases is sufficient for ophthalmoscopic examination. After twenty minutes the dilatation diminishes, and in from four to six hours it disappears entirely.

*Gelsemine* is a resinous substance extracted by Wormley from *Gelsemium sempervirens*. Its action has been investigated by Jaarsma, who found it variable in its effects. It readily produced symptoms of general disturbance, and is, therefore, unsuitable for practical application.

*Cocaine*,<sup>4</sup> the alkaloid of *Erythroxylon Coca*, introduced into ophthalmic practice by Koller,<sup>5</sup> is a most valuable anæsthetic, but as a mydriatic has little value when employed alone. The first preparations of this drug seem to have been impure and not free from other alkaloids, and therefore often had a marked influence on the pupil and accommodation. The pure drug causes only a relative dilatation of the pupil, the influence of light on the size of the pupil not ceasing. Paralysis of accommodation occurs only after repeated instillations of a strong solution, and very soon passes off. The other properties of the drug are not favorable for mydriatic purposes; for instance, the conjunctiva and cornea become dry, and the epithelium is easily injured. It is advisable, therefore, to bandage the eye or to apply wet compresses after using the drug. In combination with other mydriatics it has great merits. In the first place, it prevents

<sup>1</sup> Vide Oliver, American Journal of the Medical Sciences, September, 1896.

<sup>2</sup> E. Merck, Berichte, No. 119, 1895.

<sup>3</sup> Groenouw, Deutsche Med. Wochenschrift, No. 10, 1895.

<sup>4</sup> Koller, Wiener Med. Wochens., 1884, and Heidelberg. Ophth. Gesellschaft, September, 1884. H. Knapp, Medical Record, October, 1884. Landolt, Archives d'Ophth., November, 1884. Emmert, Correspondenz-Blatt für Schweizer Aerzte, May, 1885. Keyser, Therapeutic Gazette, 1885. Eversbusch, Aerztl. Intellig.-Blatt, 1885.

<sup>5</sup> Koller, loc. cit.

irritation of the conjunctiva and hypersecretion of tears, and it facilitates the absorption of the combined mydriatic; in the second place, it produces an additional dilatation, even when the pupil is dilated to the utmost that can be accomplished by atropine.

The hydrochloric salt is the most commonly employed, in solution of from two to five per cent. A few drops of this solution suffice to render the cornea anæsthetic within five minutes. For anæsthesia of the iris, repeated instillations during from twenty to thirty minutes are necessary.

If a mydriatic is employed for the purpose of examination, mydrin often proves sufficient; if not, a weak solution of homatropine can be used. In order to set the accommodation at rest for testing refractive errors, three or four instillations of a one per cent. solution of homatropine generally are efficient. Casey A. Wood<sup>1</sup> recommends a combination of homatropine and cocaine in gelatin disks.

In cases of spasm of accommodation, where a stronger mydriatic is required, duboisine or scopolamine or hyoscine is recommended; but for protracted use, as in inflammatory cases, atropine is more suitable, as it keeps the pupil and accommodation longer under control and is less dangerous than the other mydriatics.

#### MYOTICS.

*Myotics* are those substances which are capable of producing a narrowing of the pupil (*myosis*). If employed in sufficient strength, they act at the same time on the ciliary body, producing spasm of the accommodation.

Those derived from the Calabar bean (the fruit of *Physostigma venenosum* [Balfour], belonging to the Leguminosæ) are the most powerful.

The action of the alcoholic extract of Calabar bean on the pupil was discovered by Fraser in 1862; that on the accommodation by Argyll-Robertson in 1863, who introduced this drug into ophthalmology. Among the investigations as to the action of this myotic, we quote, in the first place, those of Donders and Hamer.<sup>2</sup>

In 1863, Jobst and Hesse discovered an alkaloid of the Calabar bean which had the same myotic power as the extract; this they named *physostigmine*. Vée and Leven also obtained an alkaloid which was named *eserine*. These two alkaloids have later been found to be identical. Another alkaloid of the Calabar bean, called *calabarine*, was discovered in 1866 by Harnach and Witkowsky. These alkaloids have replaced the extract, being more constant in action and less irritating to the conjunctiva.

The mode of action of myotics, in which they show great analogy with mydriatics, has been investigated by Donders and Hamer.<sup>3</sup> If introduced into the conjunctival sac, whether the drug be in solution, in ointment, or in gelatin wafers, it passes through the cornea into the anterior

<sup>1</sup> Pan-American Medical Congress, Washington, 1893.

<sup>2</sup> Donders, *Refraction of the Eye*, p. 610.

<sup>3</sup> Donders, *loc. cit.*

chamber and acts on the iris and the ciliary body without the intervention of the central nerve-system. Donders believed that myotics acted as stimulants on specific nerve-cells inside the eye in the course of the oculo-motor nerve.

Like mydriatics, myotics act more promptly and more energetically on the pupil than on the ciliary body. The effect on the accommodation ceases sooner than that on the pupil. Solutions not strong enough to produce ciliary spasm act on the iris. The contraction of the pupil after the application of a sufficient dose to the conjunctiva commences in from five to ten minutes, attains its maximum in from thirty to forty minutes, diminishes slowly after three hours, and disappears in from two to four days. This routine is occasionally varied by some pupillary dilatation. The whole process is more rapid than that of atropine. At the time of maximum contraction the pupil becomes smaller than in normal condition with the strongest light. This is associated with the most powerful accommodation. (V. Graefe.) Nevertheless, the influence of light does not cease. The consensual contraction especially can easily be observed by closing and opening the fellow-eye. When the pupil is in the state of maximum contraction it is mostly irregular and even angular in outline. To the eye to which the myotic has been applied objects appear much less brightly illuminated than to the other eye.

The effect on the accommodation manifests itself almost immediately after the beginning of the myosis. Both the far and near points of distinct vision move equally towards the eye. Therefore there is no loss of accommodation, as is the case after the instillation of mydriatics. Moreover, with the diminution of the action of the myotic the range of accommodation is increased, attaining its highest increment after one hundred minutes. (*Vide* Fig. 3.)

In this state of spasm a slight impulse of the will has a great effect upon the accommodation. For instance, Hamer found that one hundred and five minutes after the instillation, with a convergence to 10'', the eye in which the drug was used was not focussed at 10'', as was naturally the case with the other eye, but at 4.5''; after eleven hours it was focussed at 8.3'', with the same convergence to 10''; in fact, some difference remained in the state of accommodation of both eyes, with equal convergence, as long as the range of accommodation of the instilled eye continued to be greater than that of the other one. The eye behaved like a hypermetropic one. There was considerable accommodation with slight convergence, the reverse of what was seen when the eye was under the influence of atropine, in which there was a slight degree of accommodation with considerable convergence, as is found in myopic eyes.

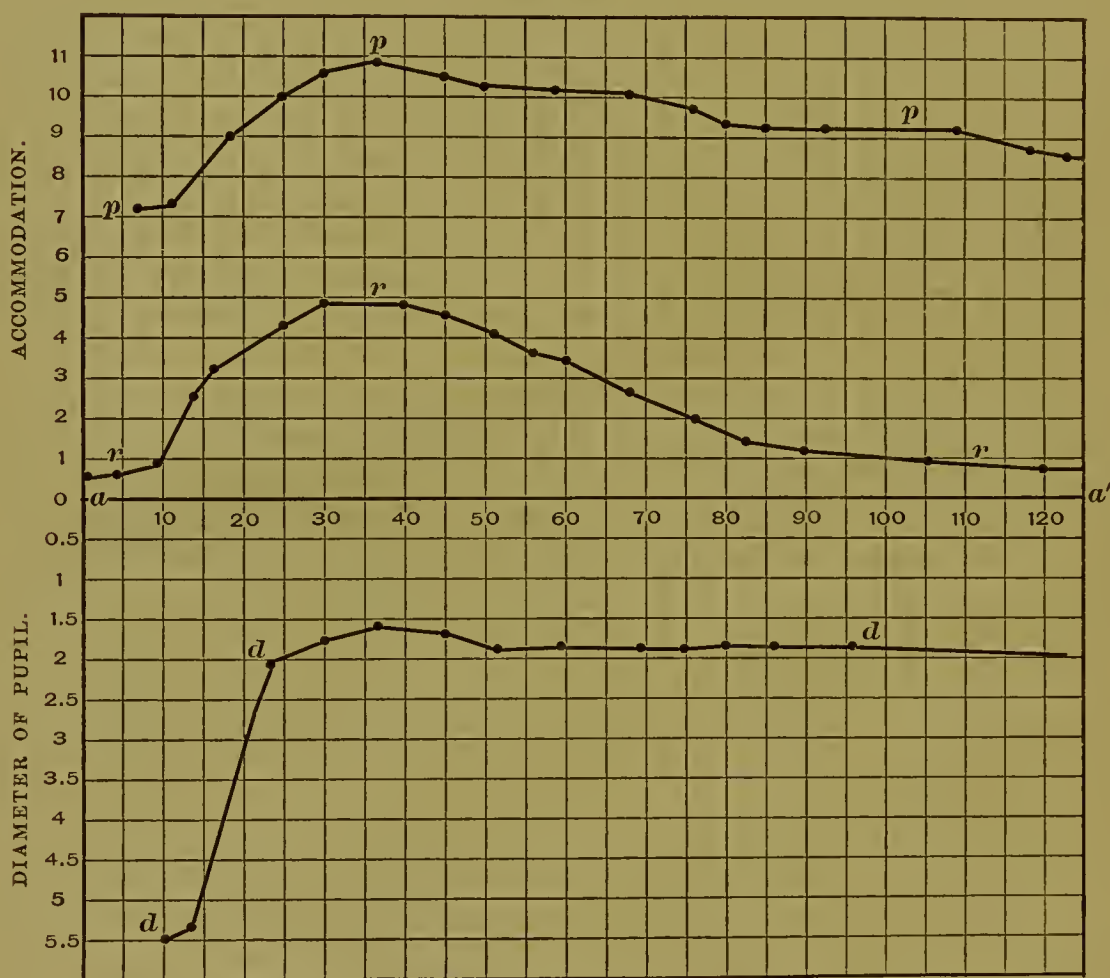
When myotics are used, it is found that, in proportion to the feebleness of the impulse required to accommodate for a certain distance, objects appear enlarged (*macropia*). The effort of accommodation being less strong, the objects are supposed to be farther away, and, as the angle of vision remains the same, they seem to be larger.

The course of the spasm of the sphincter and of the ciliary muscles is best shown by the curves in Figs. 3 and 4, which we owe to the investigations of Donders and Hamer, and which have been adapted to the metric system by Landolt.

In Fig. 3 the minutes after the instillation are indicated on the horizontal line  $aa'$ . The curves above the line show the changes of the near point of distinct vision ( $p$ ) and that of the far point ( $r$ ), expressed in diopters.

In the beginning the range of accommodation indicated by the space between the lines  $ppp$  and  $rrr$  is diminished. In another experiment, the

FIG. 3.



influence on the nearest point in the first period being greater than on the farthest point, the range of accommodation was increased. At the period of maximum action, thirty to forty minutes after the instillation, the near and far points are moved equally closer to the eye; the range of accommodation is, therefore, nearly the same as it was before the instillation. With the decrease of the action the punctum remotum returns sooner to its original place than the near point does, the range of accommodation thus becoming greater.

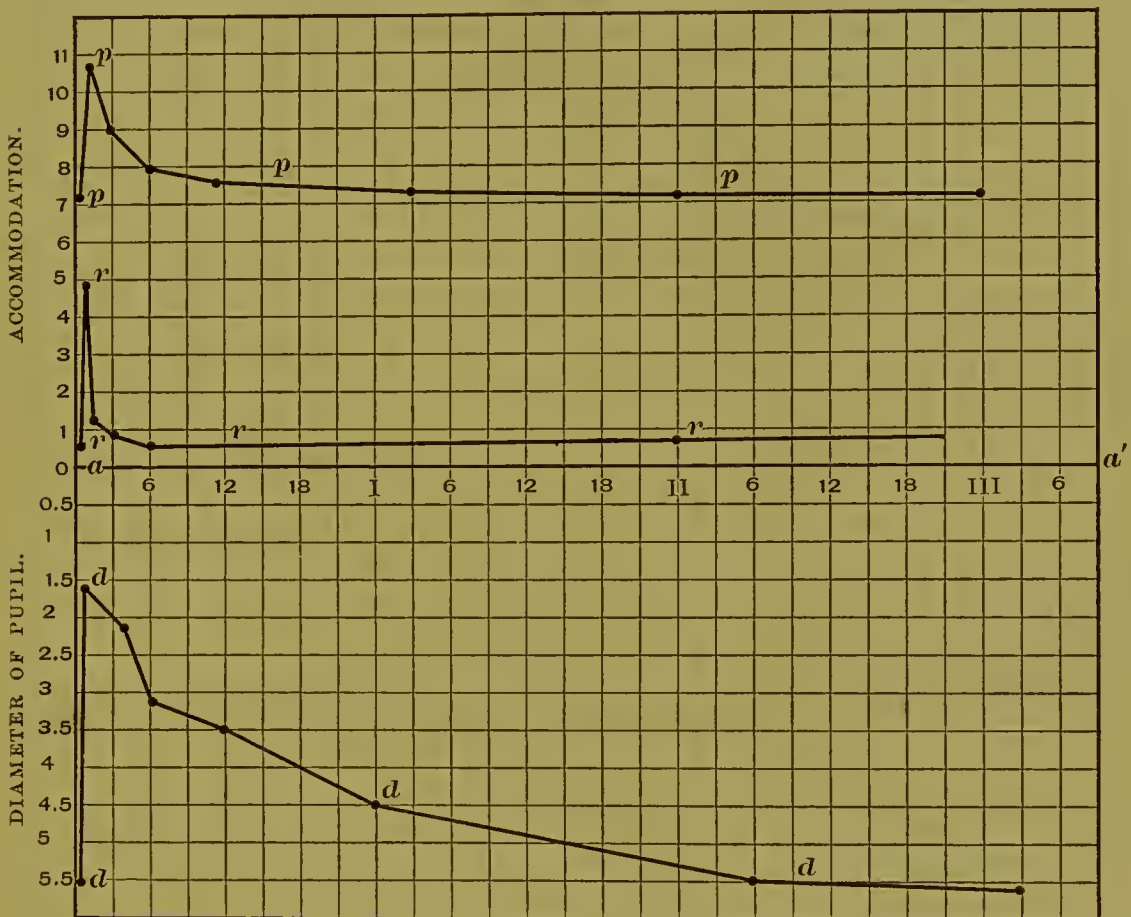
The line  $ddd$ , below the horizontal line, shows the alteration in the size of the pupil, indicated in millimetres.



Fig. 4 exhibits curves similar to those in Fig. 3, showing the gradually lessening action of the drug during the course of the first three days after its instillation. Here the influence on the far point ( $r$ ) ceases after six hours, whereas the near point ( $p$ ) regains its proper place only after twenty-four hours. The influence on the size of the pupil is still perceptible after two days.

We have already noticed that there is a marked antagonism between the action of myotics and that of mydriatics. It is interesting, therefore, to know how these two series of drugs act when instilled simultaneously or consecutively into the same eye. Hamer observed that when both drugs

FIG. 4.



were simultaneously instilled, the more rapidly acting myotic first showed its effect by contracting the pupil and producing spasm of the accommodation. This effect, however, was soon overcome by that of the mydriatic, the spasm of accommodation continuing while the pupil became wider.

Von Graefe investigated how far the action of atropine could be interrupted by the after-use of a myotic. He found that when extract of Calabar bean was applied while the action of atropine was diminishing, it was capable of temporarily producing contraction of the pupil and spasm of the accommodation. These phenomena, however, were soon followed by the ordinary routine action of the mydriatic.

According to Donders, Calabar bean is capable of lessening the size of

the pupil and of increasing the manifest refraction even when the pupil is dilated to its maximum by atropine and when paralysis of accommodation seems complete. This effect, however, is of short duration, being soon overcome by the stronger influence of atropine.

Rosbach, on the contrary, believing in the predominance of mydriatics over myotics, is of opinion that a pupil dilated by atropine can be contracted by a myotic only under exceptional conditions.

The author's observations agree with the results of the former investigators. In his left eye, which is normal, and its refraction = Hm. 0.25 D, a drop of atropine was placed, after which the pupil became dilated to its maximum and the accommodation was totally paralyzed, the refraction remaining the same. After two hours, in order to be quite sure that there was no tension of accommodation left, another drop of the same half per cent. solution of the same drug was instilled, but the refraction remained the same. The next day pilocarpine was freely applied, after which the refraction became equal to a myopia of half a diopter and increased in fifteen minutes to that of one diopter. There was no accommodation possible, and the size of the pupil was diminished to six millimetres. After twenty minutes the refraction was again emmetropic and the range of accommodation had regained three diopters, which after three hours became reduced to one diopter, and the size of the pupil again became eight millimetres. The next day—the third after the instillation of the mydriatic—the experiment was repeated; and then, by the aid of pilocarpine, the pupil could be contracted to four millimetres' diameter, and there was an increase of refraction of two diopters, which lasted about an hour. After seven days there was still a perceptible difference in the size of the pupil and in the range of accommodation in the two eyes.<sup>1</sup>

Schäffer<sup>2</sup> has observed that eserine can totally efface the mydriasis caused by homatropine. He has also shown that the drug is not capable of annulling the effect of duboisine or atropine.

From this we may deduce that myotics may be used with advantage to lessen and in some cases to annul the ill effects produced by mydriatics. They may be also employed to stimulate the action of the ciliary muscles in case of paresis. Their greatest value in ophthalmic practice, however, depends upon their power of diminishing the intra-ocular tension in glaucoma, as was determined by Laqueur<sup>3</sup> in 1876.

Von Graefe had used Calabar bean before Laqueur in the treatment of glaucoma, but only in order to facilitate iridectomy by contraction of the pupil. As it was known that atropine had a bad influence on the disease, Laqueur investigated how eserine might act as an antagonist of atropine. Since then myotics have been the principal therapeutic agents used in com-

---

<sup>1</sup> See similar results observed in a study of refraction in plastic iritis by Oliver, Transactions of the American Ophthalmological Society, 1892 and 1894.

<sup>2</sup> Schäffer, Archiv f. Augenheilk., x. S. 186.

<sup>3</sup> Laqueur, Archiv f. Ophthal., xxiii. 111.

bination with iridectomy or sclerotomy (H. Snellen<sup>1</sup>), or even without any operation (Cohn<sup>2</sup>), on account of their influence on the intra-ocular tension. A. Weber<sup>3</sup> strongly recommends their employment in the treatment of corneal ulcers. Finally, myotics may be used in irregular astigmatism for optical purposes.

We have already mentioned that the alkaloids of Calabar bean act in the same way as the extract, and that they are preferable because their action is more constant and less irritating to the conjunctiva than the extract. The sulphate of eserine is the most commonly employed salt. Very often patients complain of a slight smarting after the instillation, but the eye seems to become accustomed to it, and the instillations can be continued without unpleasant complications. In exceptional cases, however, especially when stronger solutions are used, the drug gives rise to such severe ocular pain, with headache and nausea, that it has to be discontinued.

Under the influence of light, the solution of sulphate of eserine becomes red by the formation of rubreserine, which has no myotic power.

Sulphate of eserine is used in solution of one-half to one per cent. It is desirable to add an antiseptic—as, for instance, boric acid or sublimate—to the solution. Landolt recommends the employment of the salicylate (Merck) instead of the sulphate, as this salt seems to be less irritating and more stable.

Physostigmine, as we have already stated, is identical with eserine. Another myotic, *pilocarpine*, was discovered by Hardy in 1875. It is an alkaloid derived from the leaves of jaborandi. With hydrochloric acid and nitric acid it forms crystallizable salts which are very soluble in water.

Jaarsma<sup>4</sup> investigated the action of the hydrochlorate of pilocarpine, and found it similar to that of eserine, but much weaker. While the smallest dose of eserine capable of contracting the pupil is one drop of a solution of one to twelve thousand eight hundred, the minimum dose of pilocarpine is one drop of a one to four hundred solution. The same solution of pilocarpine acts at the same time upon the accommodation, whereas eserine requires a strength of one to eight hundred to produce accommodative spasm.

After instillation of pilocarpine the contraction of the pupil begins within a quarter of an hour, attains its maximum in from thirty to forty-five minutes, and disappears within twenty-four hours. The strength of the solution seems to have no influence on the duration of the process. The strongest contraction can be obtained by a four per cent. solution. The spasm of accommodation begins about fifteen minutes after the instillation, and is independent of the contraction of the pupil. It lasts two hours and a half.

---

<sup>1</sup> H. Snellen, Donders-feestbundel, 1888, and Heidelberg Congress, 1888.

<sup>2</sup> Cohn, Berliner Klin. Wochenschrift, 21, 1895.

<sup>3</sup> A. Weber, Archiv f. Ophthalm., xxii. 4, S. 215, 1876.

<sup>4</sup> Jaarsma, loc. cit.

Hydrochlorate of pilocarpine in solution keeps well for a long time. It acts more mildly, and, according to the author's experience, patients bear it better, even in a four per cent. solution, than eserine. The usual strength of the solution is two to four per cent. As a myotic, pilocarpine is much employed in ophthalmic practice as a diaphoretic, in order to facilitate the absorption of vitreous opacities, exudations, and fluid situated behind the retina in cases of detachment. For these purposes subcutaneous injections are employed (ten to twenty milligrammes in water).

*Muscarine*, an alkaloid derived by Schmiedeberg and Koppe<sup>1</sup> from *Amanita muscaria*, is not reliable as a myotic. According to Kraenchel, who has made investigations with this drug in the clinic of Donders, muscarine produces spasm of accommodation in from five to ten minutes after the instillation into the conjunctival sac. The spasm attains its maximum in from fifteen to thirty minutes, and disappears in from one to two and a half hours. Its action on the pupil is variable. In some cases Kraenchel noticed spasm of accommodation with hardly any change in the size of the pupil. In others a strong myosis accompanied by a moderate spasm appeared. Contrary to other myotics, muscarine acts first on the ciliary muscle.

Other myotic agents, as inhalations of nitrogen protoxide (Bordier<sup>2</sup>), hypodermic injections of morphine (v. Graefe), and applications of nicotine, conium, extract of aconitine, and extract of digitaline, are useless in ophthalmic practice. (Kuyper,<sup>3</sup> Donders,<sup>4</sup> Weber.<sup>5</sup>)

The best myotic known at present is the hydrochlorate of pilocarpine, which keeps well in solution, does not produce any irritation of the conjunctiva, does not give rise to any complications or general disturbances, and, therefore, has every advantage over other myotics, except its exceedingly high price.

A new drug, *arecoline*, brought forward by Merck<sup>6</sup> in 1894, can perhaps in this respect be used advantageously as a substitute for pilocarpine. According to Merck, the hydrobromic salt of this alkaloid keeps better than eserine, acts more powerfully than pilocarpine, and is much cheaper. Lavagna<sup>7</sup> has found it useful. It does not irritate the eye, and even after repeated instillations fails to produce headache or other complications. According to the investigations of this observer, a one per cent. solution produces myosis in five minutes. The maximum of contraction of the pupil (the diameter being one and one-half millimetres) occurs fifteen minutes after the instillation and lasts for thirty minutes. After seventy minutes the pupil regains its original size.

<sup>1</sup> Schmiedeberg and Koppe, *Das Muscarin*, Leipzig, 1869.

<sup>2</sup> Bordier, *Journal de Thérapeutique*, 1876.

<sup>3</sup> Kuyper, *loc. cit.*

<sup>4</sup> Donders, *loc. cit.*

<sup>5</sup> Weber, Heidelberg, 1859.

<sup>6</sup> Merck, *Bericht über das Jahr 1894*.

<sup>7</sup> Lavagna, *Giornale della Reale Accad. Med.-Chir. di Torino*, i., 1894, and *Therapeut. Monatshefte*, 1894.

# LATERAL ILLUMINATION:

MAGNIFYING INSTRUMENTS EMPLOYED IN COMBINATION WITH LATERAL ILLUMINATION; THE USE OF HIGHLY MAGNIFYING GLASSES WITH THE OPHTHALMOSCOPE.

BY L. LAQUEUR, M.D.,

Professor of Ophthalmology and Director of the Ophthalmological Clinic in the University of Strassburg, Strassburg in Alsace, Germany.

TRANSLATED BY

HARRY FRIEDENWALD, A.B., M.D.,

Associate Professor of Ophthalmology and Otology, College of Physicians and Surgeons, Baltimore; Ophthalmic and Aural Surgeon to the Baltimore City Hospital, Baltimore, Maryland, U.S.A.

---

## I. THE PRINCIPLE OF LATERAL ILLUMINATION.

WHO has not admired the beautiful play of dust in the sunlight? Let a beam of sunlight enter an otherwise darkened room, and its path is immediately marked out by millions of fine particles of dust dancing in its course. The bright sunbeam is sharply defined by the surrounding darkness. In diffuse daylight we do not see the numberless particles at all times floating in the air; on the contrary, it appears perfectly clear and homogeneous. The explanation of this phenomenon is to be found in the following facts. The small floating particles of dust receive the diffuse daylight from all directions and are almost equally illuminated. Consequently they do not excite any visual sensation, for they do not contrast with their surroundings, and contrast is an essential requisite of every sensory perception. In the homocentric light of a single sunbeam, the particles of dust and the little crystals floating in its path are intensely illuminated (their minute surfaces sometimes reflecting like mirrors), while those in the surrounding air remain in darkness. A sharp contrast is the result, and we are enabled to perceive them easily.

This principle is applied in *lateral illumination* of the eye,—a method of examination known also as *oblique* or *focal illumination*. Though it is impossible to produce such a striking contrast as in the case of the dust in the sunbeam,—intense illumination beside absolute darkness,—still, a consider-

able amount of light can be thrown upon some portions of the eye and shade upon the neighboring parts, thus causing marked contrast. The bright light is obtained in a darkened room at or near the apex of a cone of light eoneentrated by a strong convex lens from the rays coming from a flame. The shadow is likewise due to the lens, and is thrown around the illuminated area,—a fact which does not usually receive due consideration. Some diffuse light falls upon the eye examined from the walls of the room and from the face and body of the observer, thus diminishing the contrast between illuminated and shaded parts: still, this does not eause any considerable disturbanee.

## II. OTHER FACTORS CONCERNED IN LATERAL ILLUMINATION.

It is important to vary the direction of our vision in examining by lateral illumination. A faint grease-spot or a slight unevenness in white paper is seen most distinetly when we look slantingly upon the paper. In a similar manner a little flake of mucus or an indistinet opacity of the cornea is more easily discovered. Other reasons besides eompel us to ehange the direetion of our gaze. At certain points the bright corneal reflex is very disturbing, and is avoided by ehanging the position. Furthermore, the baekground of the transparent eornea and aqueous humor varies aeording as it is formed by the dark pupil or by the eolored iris. It is obvious that a faint corneal opaieity can be best seen on the dark baekground of the pupil, while a dark foreign body is more easily discovered when viewed on the baekground of a light iris.

It is likewise necessary to alter the direction of the cone of light if the examination is to be performed in a eomplete manner. In general it is best to let the axis of the light eome from almost a right angle with the visual line of the eye examined; it is for this reason that the method has been ealled *lateral illumination*. In some examinations, sueh, espeeially, as of the lens, the angle mentioned must be mueh smaller, and the illuminaating lens is to be held more nearly in front of the patient. This may be ealled *perpendicular illumination*. The examination of pathological ehanges in the posterior eortex of the lens requires that the axis of illumination shall almost eoineide with the visual line, and artifieial mydriasis is usually necessary. In this ease the visual line of the observer must likewise elosely approach that of the eye examined.

## III. HISTORICAL NOTES CONCERNING LATERAL ILLUMINATION.

Though some of the earlier ophthalmologists (Himly, Samson, and Maekenzie) employed the convex lens for lateral illumination in isolated cases, still, Helmholtz<sup>1</sup> is to be regarded as the first to make systematic use of this method. The eredit of having recognized its great value, and

---

<sup>1</sup> Von Graefe's Arch. f. Ophthalm., Bd. i., Abth. II., S. 40. He employed this method in his examination of the ehanges oeurring during aeoommodation.

of having given it its proper place in ophthalmic practice, belongs to R. Liebreich.<sup>1</sup> In 1855, in his first publication on this subject, he likewise showed that the use of a magnifying glass, or even of a microscope, could with advantage be combined with this method. A. von Graefe<sup>2</sup> pointed out at about the same time that lateral illumination is of great service in the diagnosis of the consistency of cataract.

De Wecker<sup>3</sup> and Gayet also constructed microscopes to be used with lateral illumination. The corneal microscope, however, has never gained a footing in ophthalmic practice, on account of the great difficulties encountered in examining the living eye. The magnifying glasses, on the other hand, are of great service. Saemisch attempted to adapt the magnifying glass to binocular vision by employing a convex lens of 5 D. with an aperture made sufficiently large to admit of both eyes being used simultaneously. Though both eyes were used, true stereoscopic vision was not obtained. This has been accomplished by means of an instrument invented by F. E. Schulze and recommended by Zehender.<sup>4</sup> It is constructed by Westien, an optician in Rostock, and known as the *binocular corneal loupe*.<sup>5</sup>

A new and serviceable application of lateral illumination has recently been described by Knapp.<sup>6</sup> He has shown that intra-ocular operations such as iridectomy, and especially operations on secondary cataract, may be performed by lateral illumination and artificial light, and with especial advantage on cloudy days.

Attempts to use direct sunlight instead of artificial light for lateral illumination are to be restricted to amaurotic eyes. Diffuse daylight may also be used. Heddacus<sup>7</sup> states that diffuse daylight is as good as artificial light; but decided exception must be taken to this statement.

Priestley Smith<sup>8</sup> has recently suggested an ingenious modification of lateral illumination by substituting a concave mirror of very short focus for the convex lens. It has the advantage of enabling the direction of the cone of light to be changed from one side to the other without altering the position of the patient.

#### IV. METHOD OF EXAMINING BY LATERAL ILLUMINATION.

It is necessary to have the room quite dark. A small room in which the windows are closed with dark curtains and the walls and ceiling are of dark color will answer very well; or, in its stead, a part of the office shut off by dark curtains. As the source of light, any good oil lamp or gas-burner may be used. We have had no experience with the incandescent

<sup>1</sup> Von Graefe's Arch. f. Ophthalm., Bd. i., Abth. II., S. 351.

<sup>2</sup> Ibid., Bd. i., Abth. II., S. 264.

<sup>3</sup> Annales d'Oculistique, 1863, p. 258.

<sup>4</sup> Klin. Monatsbl. f. Augenheilk., xxiv. S. 504 and xxv. S. 496.

<sup>5</sup> I have provided it with a special apparatus for illuminating purposes.

<sup>6</sup> Von Graefe's Arch. f. Ophthalm., Bd. xiv., Abth. I., S. 262.

<sup>7</sup> Ibid., Bd. viii., Abth. I., S. 302.

<sup>8</sup> According to the oral information of Professor H. Snellen.

electric light. The lamp must be so constructed that it may be raised and lowered and the flame so arranged as to be kept on a level with the eyes of the patient. A convex lens of 15 to 18 D. is chosen for illuminating. Weaker lenses do not give sufficiently intense illumination. The lens should have an aperture of from four to four and a half centimetres. A second lens, to be used as a magnifying glass, may be from 12 to 20 D. in strength, or in its place one of the special magnifying instruments described in Section IX. can be employed.

The physician and the patient are seated opposite each other near a table. The lamp is placed at a distance of about fifty or sixty centimetres to the side and a little in front of the patient. The physician holds the lens of +15. to +18. D., with its edge between the thumb and the index finger of the right hand. The lens must be held with its plane perpendicular to the line joining the flame and the eye examined, and from six to eight centimetres distant from the latter.<sup>1</sup> The apex of the cone of light is thus thrown upon a part of the eye, brightly illuminating it. By slight movements of the hand, or of the eye or head of the patient, one part after the other of the front portion of the organ is illuminated for examination. At the same time the physician must not neglect viewing the eye from different points. If he desires to magnify the image, he will take a second lens between the thumb and the index finger of the left hand, holding it at somewhat less than the focal distance from the eye examined and placing his own eye as close as possible to it. With the fourth finger of the left hand he may at the same time raise the upper lid.

These rules may appear pedantic; still, they are not superfluous. We have often witnessed the difficulties which some beginners have in learning this simple method of examination. Sometimes their illumination is insufficient because the lens is not held in the line joining the flame and the eye, or is too much inclined, or even because it is shaded by the hand holding it. The magnifying glass is likewise often used improperly, being held too near or too far from the eye examined. The greatest enlargement is obtained when the object is situated within and very near the focal distance of the lens. If it is held farther away an inverted image is produced. By holding the magnifying glass too far away from the eye of the observer, the field is greatly reduced. All these annoyances can be avoided by closely following the rules stated above.

At this point mention may be made of a contrivance suggested by Priestley Smith, in which the sources of light and the illuminating lens are united. It is a hand-lamp about seventeen centimetres in length, containing a candle and having lenses (20 and 40 D. respectively) inserted on two sides. It is a handy instrument, and may be used to advantage whilst examining patients in bed.

---

<sup>1</sup> Noyes has devised an instrument by means of which this lens is held by a single finger, leaving the rest of the hand free.—TRANSLATOR.



## V. THE EXAMINATION OF THE NORMAL EYE BY LATERAL ILLUMINATION.

By this plan the position and division of the blood-vessels on the surface of the eyeball may be recognized with ease, and the net-like figures of the conjunctival vessels can be differentiated from the dimmer and deeper branches of the subconjunctival and episcleral vessels. With the aid of a magnifying glass, the marginal net-work of the limbus of the cornea becomes distinctly visible. As a rule, the surface of the cornea is found smooth and mirror-like, but particles of dust and flakes of mucus can be frequently seen lying upon it. These may be recognized by the fact that they change their position or disappear during movements of the eyelids.

If the illumination is very oblique, the anterior epithelial layer of the cornea may be recognized—though it is transparent—by a faint grayish reflex.<sup>1</sup> This reflex is especially distinct when a part of the corneal surface is robbed of its epithelium. The corneal parenchyma does not show any visible structure, nor is the posterior corneal surface to be seen; the cornea appearing optically to reach back to the surface of the iris. The angle of the anterior chamber—the spaces of Fontana—may be illuminated from the side, but the extreme periphery of the chamber cannot be rendered visible, because it is covered by the edge of the sclerotic. The canal of Schlemm, which we have often tried to discover by lateral illumination, does not reveal itself by any sign,—a fact which points to its being a lymph-space, and not a blood-vessel.

With its varying surface-relief, the concentric furrows, and the spots of pigment profusely scattered about in the stroma, the iris appears wonderfully distinct. Its pupillary portion containing the sphincter muscle appears thinner towards the margin of the pupil, and in many eyes shows numerous radial folds. The pupillary margin forms a sharp circular line, though there are often smaller or larger brown projections known as *ectropion uvæ*, that are produced by the dark posterior pigment surface of the iris reaching beyond the anterior surface.

The normal lens is likewise discernible within certain limits. Its anterior surface gives rise to a light gray reflex when the illumination is very slant, and when it is viewed from the opposite side. In young persons this reflex marks the lenticular star-figure with its rays and their dichotomous divisions. Under very favorable circumstances the radial arrangement of the fibres may be visible as fine streaks between the rays of the star-figure.<sup>2</sup>

It is to be noted that the vessels of the iris are not visible, except in very pronounced albinos. The posterior surface and the equator of the

<sup>1</sup> This reflex aids us in determining the depth of the anterior chamber.—TRANSLATOR.

<sup>2</sup> Laqueur, *Klin. Monatsbl. f. Augenheilk.*, xxv. S. 463, and Percy H. Friedenberg, "Die Sternfigur der Crystallinse," *Inaug. Dissert.*, Strassburg, 1891.

lens, the ciliary processes, the vitreous humor, and the fundus are not to be seen when the iris is normal. In cases of coloboma of the iris the margin of the lens becomes very distinct.

VI. THE EXAMINATION OF THE EYE BY LATERAL ILLUMINATION  
UNDER PATHOLOGICAL CONDITIONS.

Every pathological condition of the cornea, whether an injury or a foreign body, an opacity or a neoplasm, requires the use of lateral illumination for its thorough inspection. In serofulous vascular keratitis with photophobia the application of the method is often difficult, though cocaine lessens the difficulty. The gross changes of the cornea, and even some finer ones, may often, it is true, be seen by ordinary daylight, but details, boundaries, etc., escape us. In many cases diffuse daylight is entirely inadequate, as, for example, small foreign bodies in the cornea of dark eyes, or erosions of the corneal epithelium, which, though slight, may produce intense pain, congestion, and lachrymation. In this type of cases the additional use of a magnifying glass may be required for their detection.<sup>1</sup>

There is a form of keratitis that is characterized by the appearance of a great number of fine, gray, dotted infiltrations, which are invisible in daylight (*keratitis punctata vera*). Inasmuch as the disease is accompanied by considerable conjunctival congestion and irritation, it is commonly mistaken for conjunctivitis and accordingly is treated improperly. Faint opacities of the cornea, the result of inflammations during childhood, are also easily overlooked during ordinary daylight observation. Near the centre of the cornea they produce great visual disturbance, which cannot be improved with glasses. In such cases it is advisable to examine the eye by lateral illumination before testing the vision.

When interstitial or parenchymatous keratitis is pronounced, it is easily recognized by daylight. The isolated faint vascular or non-vascular opacities which often persist after the disease has run its course require lateral illumination for their detection. The same may be said of the fine superficial vessels of pannus. The deeper brush or twig-like vessels, which give rise to serious disturbance of vision and often persist throughout life, cannot usually be recognized by ordinary daylight. However, there is a method that is still better than lateral illumination for detecting these as well as the opacities to be described in the following paragraph. We refer to the use of the ophthalmoscope combined with a strong convex lens placed behind the central opening (*Loupenspiegel*).<sup>2</sup>

Iritis serosa, which is characterized by a large number of little corneal spots, deposits upon the middle and lower parts of the membrane of Des-

---

<sup>1</sup> The removal of foreign bodies from the cornea is often facilitated by the use of a magnifying glass. For this purpose a watch-maker's magnifier, which is easily held in place before the eye, leaving both hands free, is to be recommended. It requires but little practice to learn to work with but one eye.—TRANSLATOR.

<sup>2</sup> See Section VIII.

cemet, precipitated from the aqueous humor, may, if these are very close without being confluent, as is often the case, cause the cornea to appear only slightly dull. The true nature of this condition, as well as the location of the deposits upon the posterior surface of the cornea, however, will be revealed when the eye is examined by lateral illumination. As indicated above, the opacities are more easily recognized by the aid of the ophthalmoscope and the magnifying glass combined.

Extravasations of blood at the bottom of the anterior chamber (hyphæma), a coagulum of blood lying on the iris, a collection of pus (hypopyon), a fibrinous or gelatinous exudation in iritis, a lens dislocated into the anterior chamber, floating particles of lenticular substance from an injured lens or after discission, foreign bodies, and entozoa are all ordinarily visible in diffuse daylight. They are, however, seen much more distinctly by lateral illumination. When examined with the *binocular corneal loupe*, the relative position of the parts is determined exactly. It would, however, be an exaggeration to say that lateral illumination is absolutely necessary for the recognition of these conditions.

In the examination of changes of the iris and the pupillary margin lateral illumination plays an important, an indispensable, rôle. Especially is this so when the magnifying glass is used. Defects in the structure of the iris and small openings produced by perforating foreign bodies appear in diffuse daylight as round or oval black spots, which greatly resemble iris pigment. These spots are distinguished by lateral illumination by throwing the apex of the cone of light through the pupil and behind the iris, thus causing the openings to appear bright red. Large perforations and dialyses of the iris may likewise be detected with the ophthalmoscope. This method is unsatisfactory when the openings are small.

In the manner just described those spots where the posterior pigment has disappeared in atrophy of the iris may also be detected. By this plan they become bright red openings, and give a sieve-like appearance to the iris.

New growths of the iris, such as sarcomata, granulomata, gummata, cysts, and tubercles, may be recognized at an early stage by lateral illumination. When further developed, their inspection in diffuse daylight is frequently preferable to lateral illumination, because the coloring can be better seen.

Lateral illumination is invaluable in examining the pupillary space and margin. The finest thread lying in the pupil, be it a posterior synechia from the margin of the iris or a thread of a persistent pupillary membrane having its origin in the anterior surface of the iris, can be detected and distinguished. The numerous fine brown points of pigment on the anterior capsule of the lens, the vestiges of the foetal capsulo-pupillary membrane, can be recognized only by lateral illumination, or by the ophthalmoscope combined with the magnifying glass. In extensive posterior synechia, lateral illumination enables us to determine the extent and the density of the adhesion; especially is this so after a mydriatic has been

applied. In some cases careful lateral illumination will discover that a part of the pupillary edge is free and that a portion of the iris reacts to alternate illumination and shading of the pupil, though the case appeared to present complete circular adhesion.

Lateral illumination is of no little importance in some cases of anterior synechia. In a large corneal leucoma, by this method only are we enabled to determine the extent to which an iris is adherent to a scar, and the location where an iridectomy can be made with some hope of success. We find leucomata occupying four-fifths of the cornea with apparently total anterior synechia, which if examined carefully by lateral illumination show that the iris is partially free and movable behind the leucoma. Such conditions render prognosis more favorable.

Lateral illumination is practised in examining deposits upon the anterior capsule of the lens or in studying opacities of the anterior cortex in the same manner as in corneal or iritic affections. In such cases it is well to dilate the pupil with homatropine in order to inspect the peripheral portions of the lens and its capsule. The examination of the nucleus and the posterior cortex requires that the cone of light be directed more nearly perpendicularly to the pupil, and that the apex of the cone fall near the posterior pole of the lens. The patient's head is, therefore, to be turned more towards the light, and the observer is to view the eye from a point in front and somewhat to the nasal side. The rays thus passing through all the layers of the cataractous lens are reflected from the posterior surface, enabling the more consistent parts to be recognized by their peculiar color. In this manner—a method first practised by Liebreich—the existence, the size, and even the density of a nucleus may be diagnosticated. The yellowish or brownish color of the nucleus may be readily discerned. Mydriasis is necessary to determine the size of the nucleus, though the border of the cortex does not appear as a sharp line through the turbid cortex. The size and density of zonular cataract may be ascertained in a similar manner, though the examination with the ophthalmoscope is preferable in this condition. In incipient cataract, all the opacities, the little spots, the radial lines, and the larger plaques lying at various depths are rendered visible by lateral illumination. Dense opacities are also easily seen with the ophthalmoscope used in the ordinary manner. For the detection of fine opacities, Magnus's method—viz., magnifying glasses with the ophthalmoscopic mirror—surpasses all others. By this means Magnus demonstrated that the first elements of senile cataract consist of globular, pear-shaped, or tubular formations, which, though at first clear and transparent, gradually become opaque.

Lateral illumination is not suitable for the diagnosis of diffuse opacity of the lens. In advanced age the lenticular nucleus shows a decided gray reflex, which may be mistaken for developed hard cataract. By lateral illumination this reflex is likewise seen,—in fact, it may be rendered even more pronounced. In such cases the ophthalmoscope becomes necessary to determine whether the pupil and the lens are clear.

Lateral illumination is indispensable in secondary cataract. It furnishes the means of studying any membrane occluding the pupillary area, the direction of fine fibres, open spaces, and any adhesions that may be made to the iris. On the other hand, the transparency of the membrane is determined with the ophthalmoscope, alone or with the addition of a magnifying glass.

The method assists us in the diagnosis of luxation or subluxation of the lens. When the lens is situated partly in the pupillary area, its margin appears as a circular line, which, when properly illuminated, becomes bright and silvery. When the cataractous lens lies at the bottom of the vitreous humor, it may likewise often be seen from above and recognized by its bright reflex and movements.

#### VII. THE RARER APPLICATIONS OF LATERAL ILLUMINATION.

Total staphyloma of the cornea appears in ordinary daylight as a white or spotted prominence with a smooth or an irregular surface; the true condition of this membrane is revealed by lateral illumination. For this purpose the apex of the cone of light is thrown into the interior of the staphyloma, which thereupon becomes luminous. The transparency of the membrane, which is usually very thin, thus becomes evident. By this plan we also see the blood-vessels contained in it and the irregular masses of pigment (remains of the iris).

Though lateral illumination does not render any structures posterior to the lens visible when they are normal, still, there are certain pathological conditions of the vitreous humor and the retina which can be readily seen by this method. As examples may be cited: extensive detachment of the retina, retinal or choroidal tumors in their advanced stages, bright membranes in the vitreous, metallic foreign bodies, etc., which approach the posterior surface of the lens. Incidentally it may be mentioned that metallic foreign bodies in the vitreous can sometimes be seen by ordinary daylight (*vide Centralbl. für Augenheilk.*, 1888, S. 295). The examination of the vitreous becomes much easier if the lens has been removed or is dislocated. Then we readily see the little bright and floating cholesterin and lime crystals in the vitreous. When present in great quantities they may sometimes become visible by lateral illumination through the normal lens.

Occasionally the zonula and the ciliary processes can be observed, as when, after wounds near the limbus of the cornea, these parts are drawn forward by cicatricial contraction.

Lateral illumination, or, more properly, lateral transillumination, is sometimes useful in inspecting the contents of tumefied conjunctivæ. It has enabled us to recognize a lens dislocated under the conjunctiva by a severe contusion. The transparency of the fluid exudation in chemosis of the conjunctiva can be recognized, the presence of a foreign body may be determined, and a conjunctival cyst containing a cysticercus may be distinguished from a simple serous cyst, by this method.

## VIII. THE COMBINED USE OF THE OPHTHALMOSCOPE AND THE MAGNIFYING GLASS.

We have repeatedly mentioned this method as preferable in certain conditions to lateral illumination, alone or even when combined with a magnifying glass. Under this head would be included fine vascularization of the surface or the parenchyma of the cornea, the earliest traces of cataract, very small foreign bodies in the cornea, the fine precipitates upon the membrane of Descemet in serous iritis, and deposits of pigment upon the anterior surface of the lens.<sup>1</sup> Still, we must bear in mind that this method requires that the refractive media be sufficiently clear to admit considerable light, so that, when reflected, the pupil appears pinkish. The bright pupil thus becomes the background upon which the shadows of the fine spots or lines are marked.<sup>2</sup> These are seen best when they are sharply defined and when the pupil is dilated. Mydriasis is, therefore, often indispensable.

The instrument required and the method of using it are very simple. We need only fasten a convex lens of 8, 12, or 20 D. behind the central opening of any concave or plane ophthalmoscopic mirror. Instead of using a single lens, Magnus's suggestion may be adopted, and two lenses, as 9 and 11 D., be combined, thus obtaining a greater enlargement (about sixfold). The combination of three lenses still further increases the magnifying power, but their use entails difficulty. For examining the fine opacities of incipient cataract, Magnus prefers the plane mirror.

The instrument is used as in the direct method, the observer closely approximating the eye examined, so that the object viewed is near the focus of the lens used. We endeavor to illuminate the pupil with the part of the mirror nearest the central opening.

The results of this method are truly surprising. To those who have not practised it we would recommend it for the examination of corneal opacities resulting from interstitial keratitis. It is astonishing how clearly the fine ramifications of the blood-vessels can be seen, when by lateral illumination they may be invisible or seen with great difficulty. Hirschberg<sup>3</sup> thus found that the blood-vessels of syphilitic interstitial keratitis persist for many years, and he considers their presence a valuable sign of congenital syphilis. Seböbl and Nettleship have likewise used this method of examination in such cases with advantage. Magnus's interesting observations concerning the earliest appearances of cataract were made by means of this method. The plan deserves to be more widely known than it is at present.

<sup>1</sup> To these must be added dust-like opacities of the vitreous, which can be discovered only by this method. They are often overlooked, and in such cases the blurring of the retinal picture is falsely ascribed to retinitis.—TRANSLATOR.

<sup>2</sup> The most favorable light, especially when the fundus oculi is dark, is that reflected from the papilla. We therefore often find it best—sometimes absolutely necessary—to direct the patient's eye in such a way as to obtain this light.—TRANSLATOR.

<sup>3</sup> Hirschberg, *Centralbl. f. prakt. Augenheilk.*, 1888, S. 256.

IX. MEANS USED IN COMBINATION WITH LATERAL ILLUMINATION  
FOR THE PURPOSE OF MAGNIFYING.

As is well known, magnifying glasses give an enlarged, upright, virtual image of an object lying within but very near the focus. It has been mentioned above that a convex lens of 15 or 20 D., or such magnifying glasses as are used by botanists, may be employed. Besides these, certain magnifying instruments that are made expressly for this purpose will be mentioned.

1. Næchet's small pocket loupe (*petite loupe dite d'oculiste*) consists of a cylindrical metallic tube twenty-seven millimetres long and twenty millimetres in diameter, having a convex lens of 20 D. inserted at each end. Its focal distance is eighteen millimetres. The lens magnifies two to three times and gives a large field.

2. Steinheil's loupe<sup>1</sup> is a solid piece of glass embraced by a ring. It has convex surfaces at each end, and is contracted in the middle. The sides are blackened, and the contracted part thus acts as a diaphragm. It has an aperture of thirty-five millimetres and a focal distance of almost twenty millimetres. The image is very clear and the field is sufficiently large, but the instrument is somewhat heavy, and consequently it is not much used.

3. Hartnack's achromatic and aplanatic loupe consists of a short metallic tube twenty millimetres long, containing a series of lenses. They are equal to a convex lens of 60 D. The aperture is sixteen millimetres, the focal distance is very short (sixteen and six-tenths millimetres), and the linear enlargement is about fivefold. The field is quite as large as in the instruments previously mentioned.<sup>2</sup>

4. Bruecke's loupe<sup>3</sup> is a Galilean telescope (opera-glass) arranged for short distances. It is composed of two concentric metal cylinders, the inner moving into the outer as in a telescope. It is ninety-five millimetres long when drawn out, and seventy millimetres when closed. The ocular—a concave glass of about 25 D. with a diaphragm—is inserted in the inner tube; the objectives (their aperture about twenty-two millimetres) are composed of two plano-convex lenses of 20 D. and 10 D. respectively, and are inserted at the end of the outer tube. The focal distance of the objectives is about thirty-five millimetres. When the tubes are drawn out, the instrument has a focal distance of forty-eight millimetres and magnifies six times. When it is closed, the focal distance is sixty millimetres and the

<sup>1</sup> Not to be mistaken for Steinheil's *conus*.

<sup>2</sup> Similar magnifying glasses made in this country answer the same purpose. The Coddington magnifier is a single and very thick double convex lens which is grooved out around the middle, the contracted part acting as a central diaphragm. This is a very serviceable magnifying lens with good definition.

Still better are the achromatic triplets composed of one crown lens and two flint lenses cemented together. They are similar to Hartnack's loupe, and are made of various strengths (with foci of one-half inch, three-quarters inch, one inch, one and one-half inches, and two inches).—TRANSLATOR.

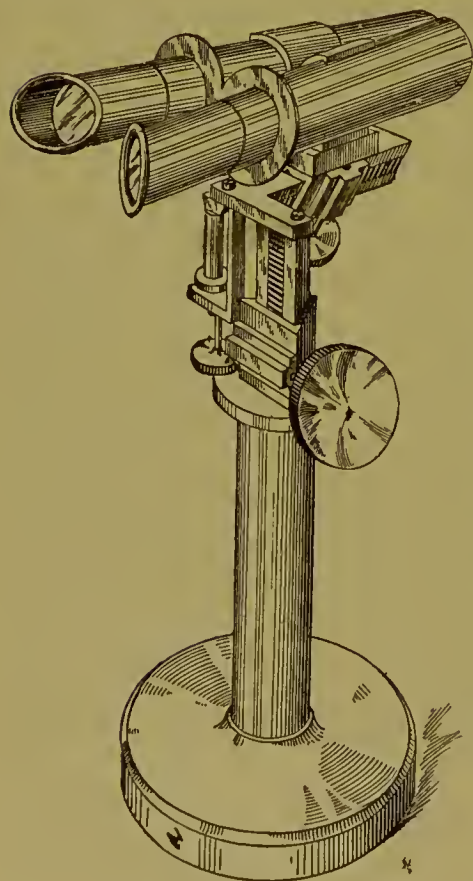
<sup>3</sup> This was, as Bruecke himself states, the invention of Chevalier; but Bruecke was ignorant of Chevalier's invention when he devised the instrument.

enlargement is four diameters. [The focal power of the lenses and their relative distance are such that the rays converging from the objective would intersect in the negative focus of the ocular, but meeting the concave ocular they pass out parallel.] The field is smaller than that of Hartnack's loupe, but the magnifying power is the same. Its advantage lies in the long focus, which permits the observer to remain at a considerable distance from the face of the patient. The weight of the instrument, however, makes it difficult to handle, and to be held steadily and kept in proper focus.

The foregoing appliances are all adapted to monocular vision. Sacmisch was the first to use a binocular instrument. It was a simple convex lens of six or eight diopters, but of a very large size (the aperture being nine or ten centimetres). It was held by a handle before both eyes of the observer, so that he could see simultaneously with both. The magnifying power of this weak lens is slight, and, though both eyes are used, there is not true stereoscopic vision. The outer parts of the lens act as prisms with their bases in, and the instrument is therefore more like "dissecting glasses" than like a stereoscope.

Stereoscopic vision combined with a high magnifying power is obtained through Westien's binocular corneal loupe. This is composed of two horizontal Bruecke's loupes which converge towards the objectives. The

FIG. 1.



inner thirds of the objectives are, as it were, blended. Two separate images are secured for the two eyes, and they are fused stereoscopically. The oculars are placed in tubes which can be drawn out and in, and they can thus be suited to any pupillary distance. The apparatus is fixed upon a solid stand, and may be raised and lowered or turned sidewise. The large screw under the objectives brings the instrument into focus. (See Fig. 1.) The head of the patient is fixed by a chin-rest which admits of being raised or lowered. The illumination is obtained in a manner suggested by us. A lamp is placed upon a table three or four metres distant, and in front of it, at a distance of twenty-five centimetres, a convex lens of 4 D. and ten and a half centimetres' aperture is mounted upon a strong stand. There is a second convex lens of 6.5 D. and eight and a half centimetres' aperture about sixteen centimetres from the patient's head. The latter

lens receives the parallel rays sent from the former and collects them in a small and very bright circle about one centimetre in diameter,—thus





FIG. 2.

large enough to illuminate at once the whole cornea. We alter the part illuminated by moving the second lens. The general arrangement is shown in Fig. 2. The preference of this method of illuminating over the lens supported by a jointed rod and attached to the instrument, such as Zehender at first used, lies in the fact that the illumination is larger and is fixed as long as the patient keeps his eye quiet, these being dependent upon the fact that movements of the instrument, such as focussing, do not disturb it.

The advantages of this instrument depend upon the magnifying power (which reaches a linear enlargement of ten diameters) and the beautiful stereoscopic effect, which enables us to recognize at a glance the relative topographical relations of the various parts. Thus we see how deeply a foreign body is embedded in the cornea, the depth at which blood-vessels lie in the corneal parenchyma, and the extent to which a tubercle or a gumma encroaches upon the anterior chamber; and yet the eye is nine to ten centimetres from the objective of the instrument.<sup>1</sup>

On account of its high price (about forty dollars), Westien has constructed a smaller, but similar, instrument, which is attached to the head of the observer (price about five dollars). This has but a slight magnifying power, but still the stereoscopic effect is present. It is far inferior to the larger instrument, as it is difficult to keep the head so quiet that the focus shall not be disturbed.

In 1855, R. Liebreich made the first attempts to examine the living eye with a microscope; for this purpose he inserted a Schick microscope in place of the mirror in his large stationary ophthalmoscope, which could be moved to and fro. The head was secured by rests for the chin and forehead. The illumination was obtained from a lens set upon a jointed rod. He states that he obtained an enlargement of ninety diameters of cornea and iris; but he also mentions that the unavoidable movements of the eye greatly impeded the examination.

In 1863, De Wecker described a similar instrument, composed of a Hartnack microscope placed horizontally (magnifying power from forty to sixty diameters). The forehead and cheeks were supported. The illumination is similar to that of Liebreich's.

Gayet's corneal microscope, invented a few years later, may be moved up and down, to the right and left, and backward and forward. To employ this plan the eye is fixed by a ring which fits around the orbit and is fastened to the instrument. The linear enlargement is from twenty to thirty diameters. The illuminating apparatus consists of a movable lens which receives the parallel rays reflected by a concave mirror.

In 1891, H. Aubert presented a binocular corneal microscope at the Ophthalmological Congress in Heidelberg,<sup>2</sup> which yields an upright picture by double inversion of the image. It produces a linear enlargement of

---

<sup>1</sup> *Klin. Monatsbl. für Augenheilkunde*, 1887, S. 496.

<sup>2</sup> *Trans. Ophth. Society, Heidelberg*, 1891, p. 260.

twenty diameters, and is ten and a half centimetres from the eye examined. The field is quite large. Concentrated daylight may be used for the illumination.

It was quite natural to think of applying the microscope to the examination of the living eye, and great hopes were built upon it. They have not, however, been realized, and they can never be realized, because of insurmountable difficulties. The short focal distance—less than one centimetre, even with low powers—and the unavoidable slight movements of the eye cause mechanical irritation of the eyelids and injuries of the cornea that may be serious. Furthermore, the field is so much narrowed that it becomes very difficult to find any particular spot. The greatest difficulty, however, is that, owing to the movements of the eye, any part can be rarely observed for half a minute before it disappears out of the field or out of the area of illumination. This difficulty is less pronounced in Aubert's microscope, but even with this instrument it is not entirely avoided.

The use of the corneal microscope is illusory. There is no new fact that owes its discovery to the microscope in its application to the living eye. Whatever can be seen by its means can be seen more easily and surely with the binocular corneal loupe. For this reason it is rarely used, and it is doubtful whether it will ever be useful in examining the living eye.

An enlargement of from ten to twenty diameters may be easily obtained with a small telescope for short distances. Thus, we have frequently used the ophthalmometer of Javal-Schiötz by taking out the double-refracting prism and illuminating the eye by our method as described above. The eye is twenty centimetres distant from the instrument, and the field is quite large. As we use but one eye, we do not get the stereoscopic effect of the binocular loupe: besides, the image is inverted.



# THE OPHTHALMOSCOPE AND THE ART OF OPHTHALMOSCOPY.<sup>1</sup>

BY GEORGE M. GOULD, A.M., M.D.,

Late Ophthalmologist to the Philadelphia Hospital, Philadelphia, Pennsylvania.

---

UNTRAINED minds accept things as they appear, without asking for causes or reasons. Every-day occurrences are noted by mankind for centuries, even for thousands of years, and nobody attaches any significance to the phenomena observed, and everybody is contented in the conviction that things are so because they cannot be otherwise. Here the matter rests until some genius works out a new law and shows a better and clearer understanding of some part of the universe. It needed a Newton to teach us the law of gravitation, although the falling of bodies to the earth had been observed since the very infancy of the human race; slings and swings were old in Galileo's time, but it was left for him to teach us the science of the pendulum. Diseased conditions of the interior of the eye had long been studied in cadavers, but it required the genius of Helmholtz to give us, in the beginning of the second half of this century, an instrument with which to examine the interior of the living eye.

That the eyes of some animals emit a phosphorescent glow in the dark must have been known even to prehistoric man when he hunted the cave lion, but not until the sciences of optics, anatomy, and physiology had sufficiently developed to formulate a rudimentary knowledge of the laws of light and of the nervous system was any explanation offered. The glow of the eye was looked upon as due to luminous rays produced *in* the eye under the influence and control of the nervous system and visible to the observer through the transparent cornea. The peculiar function of the *tapetum lucidum* in night-prowling animals makes the glow from such eyes very intense and easily seen. Instead of arousing true scientific inquiry, the phenomenon seems, indeed, to have had the contrary effect, both as to the discovery of this peculiar structure and its function, and as to the reason for the strange darkness of the human pupil.

Not until the early part of the present century do we find exceptions taken to this view. Rudolphi<sup>2</sup> calls attention to the fact that the lumi-

---

<sup>1</sup> I am indebted to Professor Julius Pohlman, of Buffalo, New York, for much research-work in the preparation of this article.

<sup>2</sup> Lehrbuch der Physiologie, 1810.

luminosity is visible only when the observer looks in a certain definite manner into the animal's eye. Gruithuisen<sup>1</sup> maintained that the phenomenon was due to the tapetum and to the extraordinary refraction of the light-rays in their passage through the crystalline lens. Prévost<sup>2</sup> noticed that a luminous eye is never seen in an absolutely dark room, and hence concluded that the appearance can be nothing else than the reflection of light-rays passing into the eye. Esser<sup>3</sup> in 1826 asserted that the varying coloration of the glowing eye was due to the different colors of the tapetum brought into view by the movements of the eyeball. Hassenstein in 1836<sup>4</sup> attempted to show that the eye was shortened by pressure of the eye-muscles, and that the change of axis thus produced influenced the luminous appearance seen in the dark. Behr in 1839<sup>5</sup> gives for the first time a correct explanation of the phenomenon, but apparently without understanding its principle. He had the opportunity of examining the eyes of a girl with total aniridia, and found that the eye of the observer must look nearly parallel with the rays of light that enter the patient's eye, in order to see the luminosity, and that it disappeared so soon as the observer's eye was held below the light. Behr merely published the fact, without attempting any explanation. In 1846, Cummings<sup>6</sup> adds to this knowledge by stating that such observations must be made in a dark room, with the candle held from eight to ten feet in front of the patient's eye. Finally, Brücke, as the result of investigations extending from 1845 to 1847,<sup>7</sup> gave a *résumé* of the subject and a correct explanation of the principles underlying the phenomenon, and these results were fully corroborated in 1853 by Coccius.<sup>8</sup> Brücke, indeed, came near making the discovery of the ophthalmoscope when he placed a tube through the flame of a candle, by which his own eye caught some of the rays reflected from the eye-ground of the observed eye.

In the light of our present knowledge it seems strange that so many careful observers should have devoted their energy for over thirty years to what now seems to us so simple a problem, and yet in the slow evolution of the understanding of the principle the work of each was necessary for the final solution, and each added his share to the gradual development of the science of ophthalmoscopy.

It is noteworthy that in all the attempts to explain the luminosity of eyes in darkness, the illumination of the interior of the globe for an exam-

<sup>1</sup> Beiträge zur Physiognosie und Ontognosie, 1810.

<sup>2</sup> Bibliothèque Britannique, xlv.

<sup>3</sup> Karsten's Archiv für die Gesammte Naturlehre, viii. 399.

<sup>4</sup> De luce ex quorundam animalium oculis prodeunto atque de tapeto lueidæ, Jenæ.

<sup>5</sup> Hecker's Annalen, i. 373.

<sup>6</sup> Medico-Chirurg. Trans., London, vol. xxix.

<sup>7</sup> Anatomische Untersuchungen über die so-genannten leuchtenden Augen bei Wirbelthieren, Mueller's Archiv f. Anat. und Phys., 1845, S. 387; and Ueber das Leuchten der menschlichen Augen, *ibid.*, 1847, Ss. 225, 479.

<sup>8</sup> Ueber die Anwendung des Augenspiegels, Leipsic.

ination of the fundus was entirely ignored, or, if thought of, was never mentioned in any of the numerous publications, although Méry as early as 1704<sup>1</sup> published the fact that he was able to see the blood-vessels and the color of the retina in the eye of a cat which he accidentally held under water, and De la Hire in 1709<sup>2</sup> had given a correct explanation of the phenomenon. The glowing eye had fully engrossed the attention of all students, and the possibility of examining the fundus of the living eye was lost sight of for nearly a century and a half,—and even so late as 1845, when Kussmanl wrote a prize essay<sup>3</sup> on the colors visible in the human eye.

At last Professor von Helmholtz, in 1851, gave to the world an instrument which he called the *ophthalmoscope*, by means of which he “does not doubt that all the pathologic changes in the retina and vitreous humor, so far observed only in the cadaver, can be seen in the living eye: a fact which promises great progress in the little-known pathology of this organ,”—certainly a promise which the last forty years have abundantly verified.

In the history of science it very often happens that two investigators, or even more, in complete independence of each other, have simultaneously discovered or invented the hitherto unknown. The one who first puts on record the most certain and clear account of it is he that is most honored. It is not improbable—of this we cannot be sure—that the essential principle of the ophthalmoscope was clearly recognized, and even a simpler application of it made, prior to the announcement of Helmholtz. Professor Wharton Jones announced,<sup>4</sup> three years after Helmholtz’s publication, that “Mr. Babbage had showed him seven years ago—*i.e.*, in 1847—an ophthalmoscope which consisted of a plain mirror with the silvering scraped off at one or two small spots in the middle. This mirror was fixed in a tube at such an angle that the rays of light falling on it through an opening in the side of the tube were reflected into the eye to be observed, and to which one end of the tube was directed. The observer looked through the clear spots of the mirror from the other end of the tube.” Jones further remarks that “it is much to be regretted, for the sake of British ophthalmic surgery, that this discovery was not made public or even utilized at an earlier date.” Supposing this to be fact, and not merely hearsay, it does not in any way detract from the honor due to Helmholtz. No other publication, not even the briefest notice, exists anywhere of Mr. Babbage’s instrument previous to the announcement made in 1854 by Professor Jones.

Helmholtz<sup>5</sup> found that when light strikes a polished glass plate some of it passes through and some is reflected. More is reflected when two plates of glass are screwed together; more yet with three, etc.; and his

<sup>1</sup> Annales de l’Académie des Sciences.

<sup>2</sup> Ibid.

<sup>3</sup> Die Farbenercheinungen im Grunde des menschlichen Auges, Heidelberg.

<sup>4</sup> British and Foreign Medico-Chirurgical Review, October, 1854.

<sup>5</sup> Der Augenspiegel, Berlin, 1851.

original instrument (Fig. 1) consisted of four thin plates of glass carefully polished, screwed together, fastened at an angle of fifty-six degrees to a brass disk, and forming the hypotenuse of a right-angled triangular prism. The other sides of this hollow prism were made of metal, and all

carefully blackened inside. The brass disk had a hole in its centre and an arrangement to place a concave lens over it; for normal eyes Helmholtz used a No. 10 glass. The light from a lamp falling on the glass plates was in part reflected into the patient's eye, and the observer, looking through the concave lens and the opening in the brass disk, received the returning rays in his own eye, and was able to see the fundus, weakly illuminated, but still distinctly.

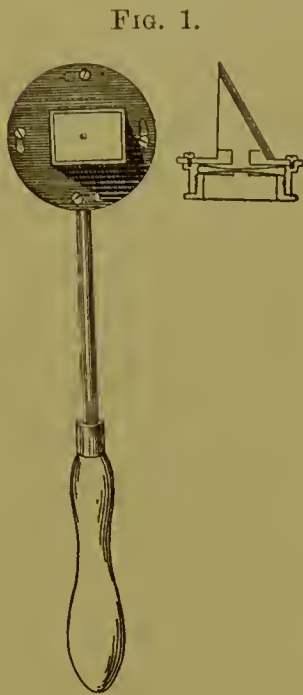


FIG. 1.

Proceeding on the lines of the invention of Helmholtz, Frobélius<sup>1</sup> recognized the necessity for better illumination, and substituted for the four thin glass plates of the Helmholtz instrument a solid right-angled prism with a hole drilled through it in such a way that the observer could see the fundus of the eye without looking through glass. We may also mention the variation of Ulrich,<sup>2</sup> who combined in 1853 two equal-sided right-angled prisms in such a way that the hypotenuse of the one stood at right angles with the hypotenuse of the other prism. (Fig. 2.) With this arrangement a ray of light striking the prism at *a* was reflected at a right angle into the patient's eye at *P*;

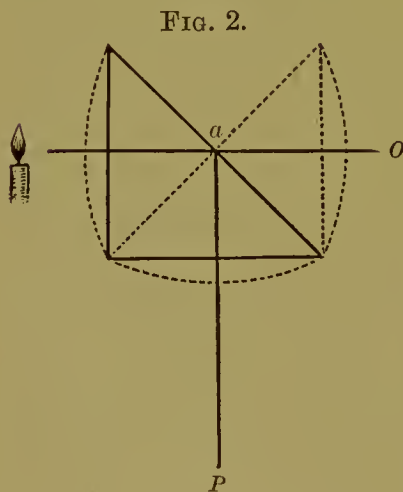


FIG. 2.

when leaving the eye it would again be reflected at *a* into the observer's eye at *O*. In this way Ulrich utilized the total reflecting power of his prism. In order to concentrate the light-rays, the external surfaces were ground convexly.

Meyerstein's ophthalmoscope<sup>3</sup> is a further improvement, with a right-angled prism at one end (Fig. 3), upon which the light falls and is reflected at right angles from the hypotenuse into the eye of the patient, the observer seeing the fundus through the hole drilled in the prism. Later Meyerstein

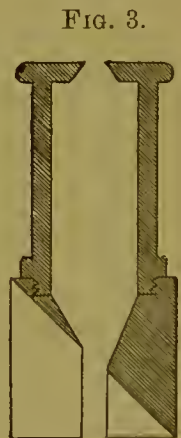


FIG. 3.

<sup>1</sup> Med Zeitschr. Russlands, 1852, No. 46.

<sup>2</sup> Zeitschrift für rationelle Medizin, neue Folge, iv. 175.

<sup>3</sup> Ibid., iv. 310.

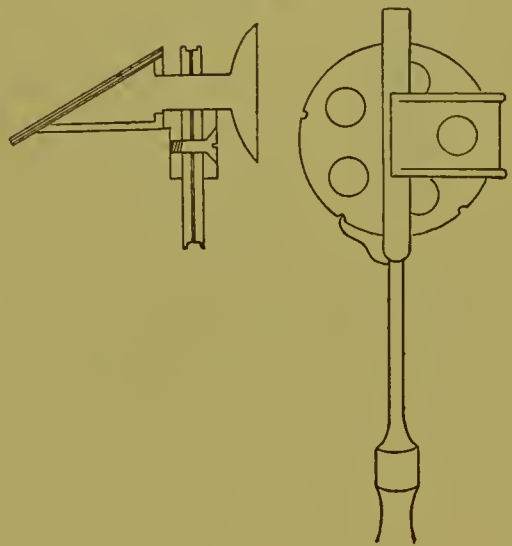


substituted a perforated plane mirror for the prism, adding a movable tube for the accommodation of distances, and a lens to collect the rays of light; this was fastened by an adjustable bracket holding a wax candle to the tube; his earlier simple instrument was thereby rendered rather cumbersome and clumsy.

But, while everybody has honored Professor Helmholtz for the scientific parts of the ophthalmoscope which he gave to the world, mankind has almost forgotten the man who made the first mechanical improvement on the instrument. Helmholtz's original device had merely a holder for one lens, and for different conditions this lens had to be changed again and again until the right one was found.

The revolving disks, carrying a series of lenses, were invented by Rekoss, of Königsberg, Prussia. (Fig. 4.) The two disks had each five round openings; four of these were filled with concave lenses from six to thirteen inches in focal length; the fifth was empty; by a simple turning of the disks, any one lens or any combination of two lenses could be utilized. A small spring kept the disks in place. Mr. Rekoss was a "Mechaniker," a term for which the English language has no exact equivalent. Most German text-books, when

FIG 4.



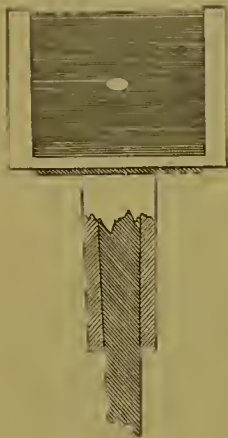
speaking of the ophthalmoscope, mention the Rekoss disks, but the English-speaking nations have not done justice to the mechanical mind that added so much to the scientific parts of the instrument to make it one of precision and easy of manipulation.

Usually when some new principle in applied science has been evolved and given to the world in the form of an instrument or apparatus, it is elaborated and made more and more complex (and sometimes more clumsy) by so-called improvements, until, little by little, in the course of time it reaches simplicity and perfection. The ophthalmoscope has followed this rule. The original instrument of Helmholtz was simple and easily handled, and, as has been said, has "even to-day no superior in its powers when weak illumination is desirable, or when the study of the faintest opacities in the media or of the slightest changes in the tint of the optic-nerve head and the blood-columns of the retina is desired." Helmholtz himself admitted that only a weak illumination of the fundus of the eye was attainable by his instrument, and, as a matter of course, the question how to improve this shortcoming was the first to engage the attention of those for whose use this instrument was especially designed.

To us it seems strange indeed that Helmholtz should not at once have seen that a piece of an ordinary mirror with a hole through it, or with the

amalgam or "silvering" scraped from a spot, would give the perfect illumination desired. It was, however, only a few months after the original publication in December, 1851, that Epkens, of Amsterdam,<sup>1</sup> published an account of a new form of ophthalmoscope (Fig. 5), in which this plan was followed. A small mirror with some of the silvering removed from an

FIG. 5.

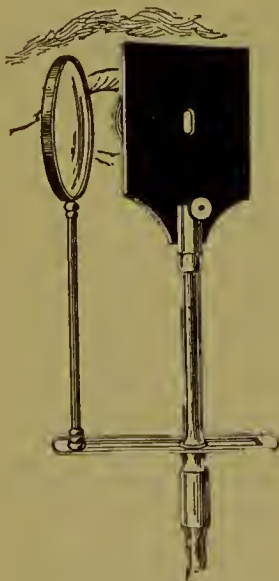


oval space in the centre was substituted for the series of glass plates of Helmholtz. The illumination was further improved by Ruete, of Göttingen.<sup>2</sup> To him belongs the honor of having been the first to use a concave mirror with a hole drilled through the centre. He had the mirror mounted on a stand in such a way that it was movable in all directions. On one side of the stand a screen was fastened to shield the observer's eye from the rays of the lamp; on the other side was a movable arm on which slid two lens-holders. The lenses could be changed with ease, and lifted, lowered, or taken out entirely, as occasion demanded. Ruete's instrument was more or less stationary on a small table, and he himself admits that

"for irritable and inflamed eyes he prefers Helmholtz's simpler form to that of his own designing."

Coeius, in 1853, elaborated Epkens's<sup>3</sup> instrument by adding a movable and adjustable arm on which could be fastened lenses of different strengths. (Fig. 6.) This enabled him to put the lens between the mirror and the

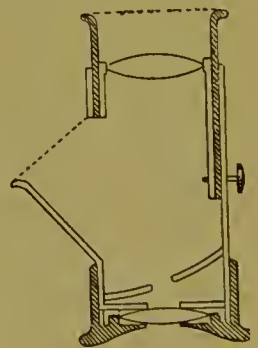
FIG. 6.



patient's eye, or between the mirror and the light, as he thought best for correct examination. The mirror was movable on its handle, and the little screw at its back kept it at any desired angle. It was a portable instrument, and, with the lens-holder removed, was conveniently carried in a pocket-case six inches long.

Ulrich<sup>4</sup> published in 1853 a new form of ophthalmoscope. (Fig. 7.) It consisted of two tubes fastened to each other at an angle of forty degrees. The longer one, the "observation tube," was five inches in length and one and two-thirds inches in diameter; the shorter one, the "illumination tube," was only

FIG. 7.



two inches in length and somewhat narrower. The interiors of the tubes were blackened. The small tube had at its open end a movable arm that

<sup>1</sup> Nederlandsche Weekblad voor Geneeskundigen.

<sup>2</sup> Der Augenspiegel und das Optometer, 1852.

<sup>3</sup> Anwendung des Augenspiegels nebst Angabe eines neuen Instruments, Leipsic.

<sup>4</sup> Zeitschrift für rationelle Medizin, neue Folge, iv. 175.

held a small candle as the source of illumination. One end of the large tube contained a concave perforated mirror and a convex lens four and one-half inches in focal length; the other end held a convex lens one and one-half inches in focal length; the latter was movable by means of a screw, so that the image of the fundus could be brought to a focus at the observer's eye behind the mirror. To shield the eyes of both patient and physician from the direct rays of the candle, one screen was fastened to the tube between the light and the patient, another between the light and the observer. The special advantage claimed for this form of ophthalmoscope was that it could be used in daylight, whereas all other instruments needed a darkened room for the examination of patients.

In 1854, Stellwag von Carion described his modified form of ophthalmoscope<sup>1</sup> (Fig. 8), and it is remarkable that after this almost perfect style of instrument had been devised so many new and cumbersome improvements followed in the succeeding four years. Stellwag's instrument consisted of a concave perforated mirror fastened to a holder by a ball-and-socket joint, an arrangement that permitted it to be placed at any desired angle to the light. Behind this mirror was placed a Rekoss disk with eight lenses, usually +2, +4, +8, +10, +12, -2, -6, and -12. The whole instrument could be placed in a box six inches long and two inches wide, and was, therefore, of a convenient size.

Examples of elaborate and cumbersome ophthalmoscopes are those of Liebreich and the so-called Epkens-Donders instrument.

Liebreich described in 1855<sup>2</sup> a "new ophthalmoscope" (Fig. 9), as follows. Two telescoping tubes, adjustable by means of screws, are supported by a stand fastened to the edge of a table. At the observer's end is a small, concave, movable, perforated

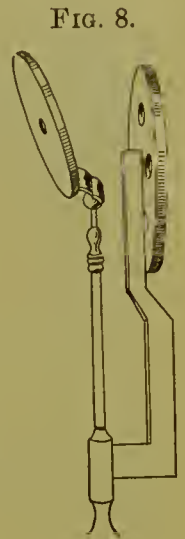
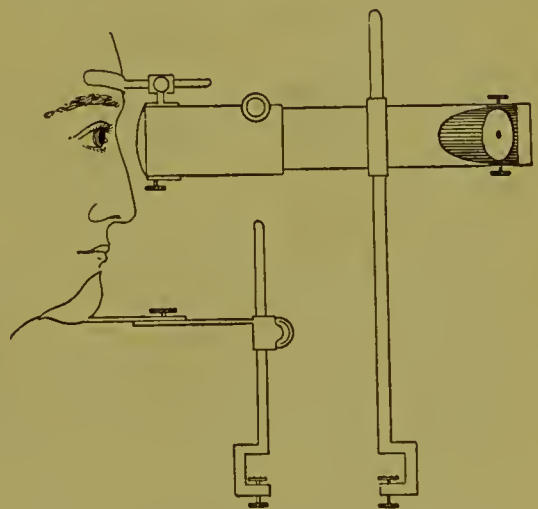


FIG. 8.

FIG. 9.



mirror, and a section of a tube is removed to allow the light of a lamp to fall upon it. The other end of the tube at the patient's eye holds a concave lens of two-inch focal length. The patient's chin rests on another adjustable stand, and the head receives additional support from a "claw," attached to the tube, in which the forehead rests. The light

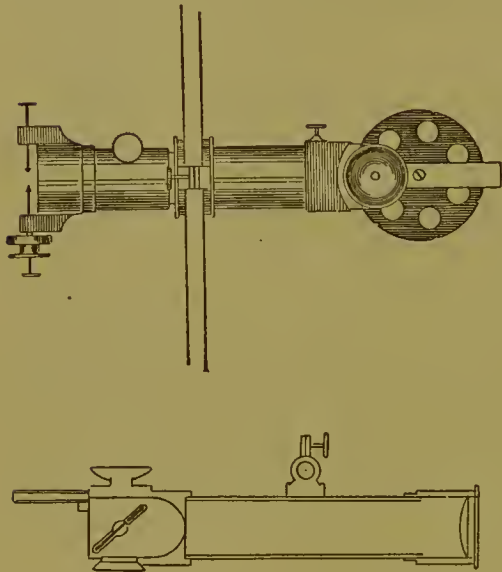
<sup>1</sup> Theorie der Augenspiegel, Wien.

<sup>2</sup> Archiv für Ophthalmologie, 1, 2.

of a lamp reflected from the mirror along the tube into the patient's eye gives the observer the opportunity to examine the fundus through the hole in the mirror. Shades were placed on the sides of the lamp in such a manner as to protect the non-used eyes of the patient and physician. By placing a camera lucida in the tube at the observer's end, a correct picture of the fundus could be drawn on the table. It may be noted that Liebreich was the first to photograph the interior of the eye\* by the aid of this instrument.

Another elaborate instrument was that of Epkens-Donders.<sup>1</sup> (Fig. 10.) A cubical box held diagonally a plain mirror perforated in the centre;

FIG. 10.



this mirror could be rotated by means of screws. The box had openings on three sides,—one opposite the reflecting surface of the mirror for the patient's eye, one behind the mirror for the observer looking through the lenses of a Rekoss disk and the central perforation into the fundus of the eye, and the third for the tube that admitted light to the mirror. The whole instrument was fastened by an adjustable stand to the corner of a table, so that observer and patient could sit opposite and facing each other, with the instrument between them. The light-tube had at its ex-

tremity a convex lens of small foetal length, to collect the rays of a lamp placed opposite. These rays struck the mirror, and, after adjustment of the instrument, were reflected into the patient's eye, illuminating the fundus. A micrometer screwed into the end of the light-tube had, when properly focussed, its two sharp points pictured on the fundus, and, as the tube with micrometer could be turned on its own axis, an exact measurement of all spots, changes, etc., could be obtained. Then, knowing the distance between the micrometer points and the length of the tube, the exact size of blood-vessels, nerve-head, and discolorations could be determined. A camera lucida could also be placed at the observer's end of the tube, permitting a correct drawing of any desired part of the fundus.

Of all the old styles of ophthalmoscope only one has survived unchanged and is made and sold to-day in exactly the same form which it had when first invented. Liebreich's small ophthalmoscope (Fig. 11) consists of a concave perforated mirror fastened to a handle. On the side of the mirror is a movable arm with a lens-holder fastened in such a way

<sup>1</sup> Verbeteringen an dem Oogspiegel, Jahrg. iv. 131.

that the lens can be swung close behind the opening in the mirror. A large convex lens accompanies the instrument for the examination of the inverted image, and other smaller ones correct the refraction-error of the observer.

While the discovery of the ophthalmoscope stimulated research on the physiology and pathology of the eye by means of artificial illumination, the knowledge that the fundus is visible when the eye is immersed in water, although ignored for one and a half centuries, came in for its share of attention. Czermak<sup>1</sup> devised a cup for this purpose, which he called the orthoscope. (Fig. 12.) Two of its sides were made of metal, and two of glass. He surrounded the eye to be examined with a thick layer of dough, filled the cup with water of eighty-five or ninety degrees' temperature, had the patient lean forward and close the eye, then the edges of the cup were pressed into the dough to prevent leakage. After this the eye was opened and a clear examination of the fundus was obtained.

Arlt<sup>2</sup> modified Czermak's orthoscope by making it of soft rubber, with one glass side; this simplified the instrument by doing away with the cumbersome dough, and yet allowed it to be closely applied to the eye. Coccius devised a cup (Fig. 13) the rim of which was made to fit tightly around the eye and the bottom of which was made of glass; this could be held to the eye close enough to permit an examination. It was said that the use of the orthoscope required less skill than that of the ophthalmoscope, although more disagreeable to the patient; and that in cases in which corneal opacities were to be studied carefully, or when the fundus was obscured by an irregularly shaped cornea, the examination under water gave the best results. These instruments are of little interest except from an historical stand-point.

From 1852 to 1858 the so-called improvements of the ophthalmoscope and descriptions of new instruments became, as it were, epidemic, the number of new forms increasing at a surprising rate, every country contributing a larger or smaller share. As some thought that monocular vision could not be so accurate as binocular vision, much ingenuity was wasted upon the invention of binocular instruments. Auto-ophthalmoscopy, an idea quite early broached by Coccius after the original discovery

FIG. 11.

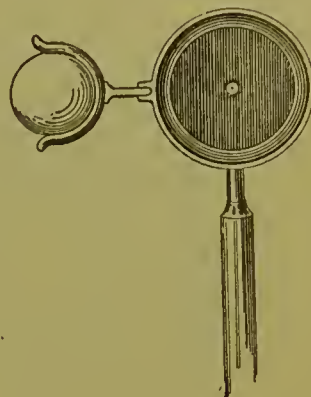


FIG. 12.

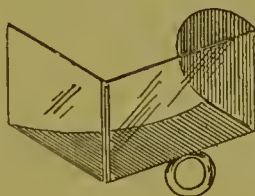


FIG. 13.



<sup>1</sup> Prager Vierteljahrsschrift, Bd. xxxii.

<sup>2</sup> Lehrbuch der Krankheiten des menschlichen Auges, Wien, 1856, vol. iii.

by Helmholtz, was followed out and gave birth to a long series of more or less cleverly conceived auto-ophthalmoscopes. But as time passed and the test of practical use was applied, the many cumbersome forms and useless modifications were slowly but surely eliminated, and to-day they are interesting only historically. In spite of this there are to-day probably more differently named ophthalmoscopes in the markets of the world than there are of any other form of instrument for a single purpose, not even excepting the obstetrical forceps; the differences between them are usually matters of small moment. A change or modification never so trifling immediately produces a so-called new instrument, named, of course, after the inventor; used, however, as a rule, only by the students and followers of a particular ophthalmologist. Such serve well enough their purposes of satisfying vanity and of illustrating the catalogues of enterprising opticians.

There are, however, a few ophthalmoscopes of modern invention which have stood the test of time and have reached as near perfection as is, perhaps, possible. After many experiments, the illuminating powers of the ophthalmoscope have been clearly perfected. For direct observation a plane mirror, and for indirect a concave mirror, is now almost universally accepted, although some observers prefer a weak concave to the plane mirror. The mirror itself for direct work is either hinged, so that it can be tilted from twenty to twenty-five degrees to each side, or made to revolve at any angle (the former method preferable), an arrangement that permits the instrument to be held in an upright position before the eye. The sight-hole is now always made circular, the lenses fit as closely up to it as possible without interfering with free movements, and in this manner the loss of light and distortion of rays coming from the patient's eye are reduced to the minimum. Some ophthalmoscopes have the two mirrors hinged in such a way that either can be swung into place when desired; others have them separate, so that one must be taken out when the other is wanted.

The best instrument must always be that which under all conditions gives the best results in the easiest and simplest way for both patient and observer. Liebreich's ophthalmoscope is undoubtedly the simplest, but the unhandy changing of lenses makes it very inconvenient for even approximately exact results. Helmholtz's instrument with the Rekoss disk, while good enough for much work, has not a sufficient number of lenses to admit of delicate adjustments. The rotating disk that holds the lenses is in itself self-limiting in regard to the number of glasses it can hold and yet remain of convenient size; two disks with different lenses moving against each other allow of an increased number of combinations, but need elaborate and complex mechanical arrangements to facilitate such combinations and to enable one to know what glasses are before the observer's eye.

Dr. Loring, of New York, has tried to overcome the difficulties of the double disk by having one with fifteen lenses,—seven convex and eight

concave,—giving a sufficient variety for all ordinary cases. (Fig. 14.) To this he added a quadrant of another disk (Fig. 15), which held two plus and two minus lenses, each of 0.5 and 16 D respectively. Between these two he was able to obtain any possible combination of lenses that

FIG. 14.

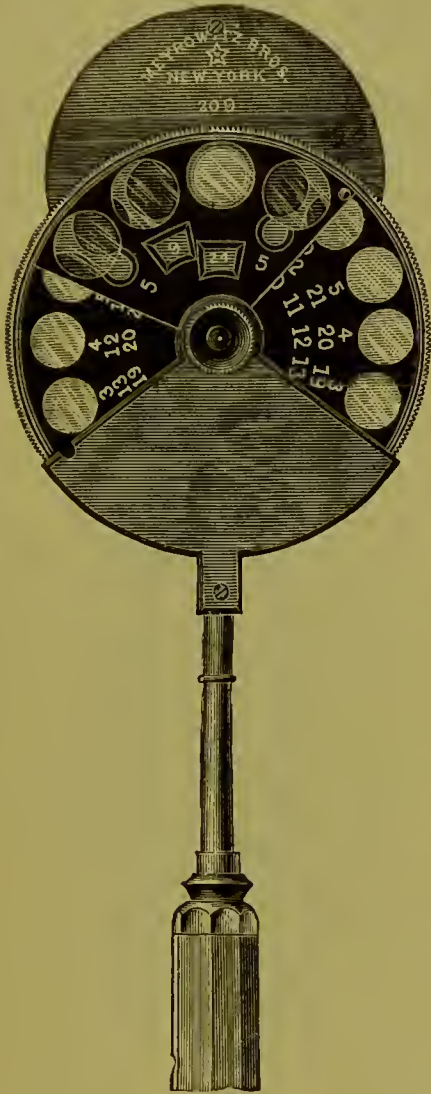


FIG. 15.

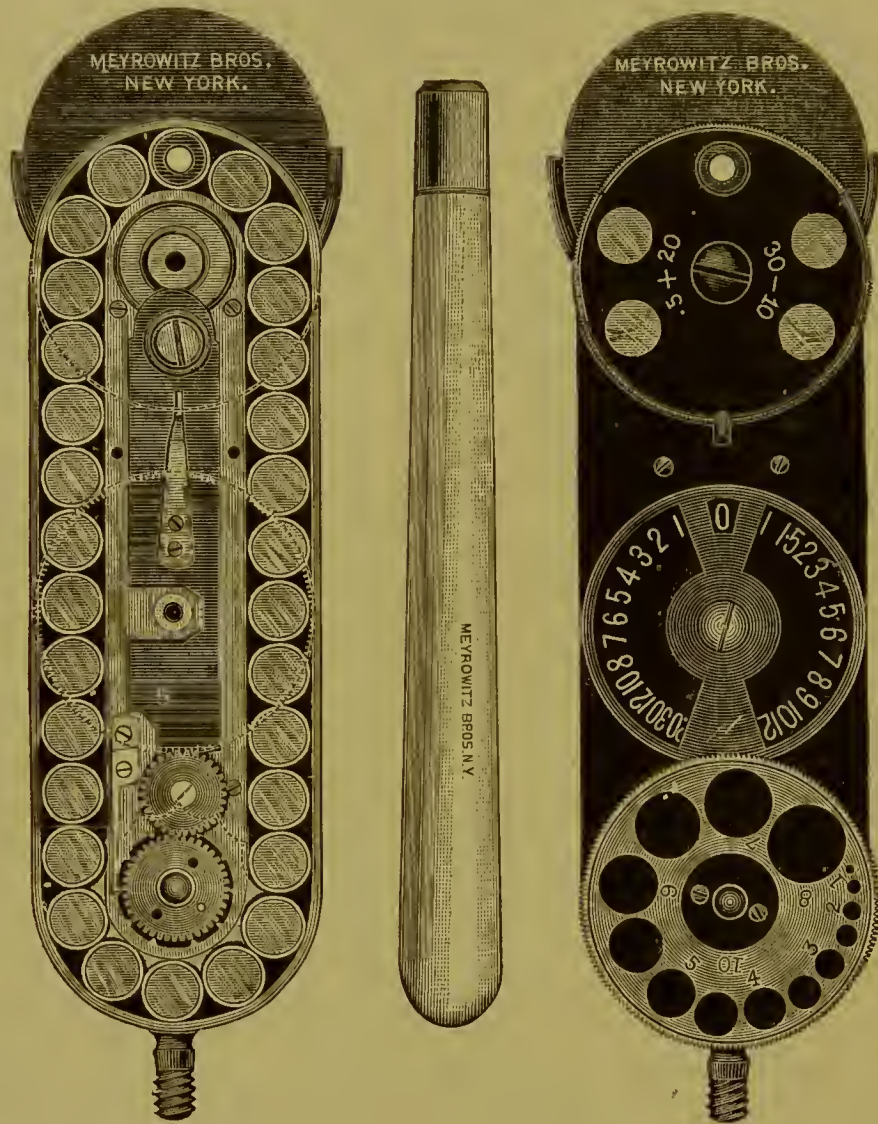


could be called for at any time in ophthalmic practice; but in order to have the disk hold so many lenses they had to be very thin, and that proved a rather serious drawback, necessitating extra care in making, in centring, and in cleaning the lenses. Another disadvantage that many find in using this instrument is, that the surgeon's index finger, in operating the revolving disks, is frequently in contact with the patient's nose, thus interfering with freedom of motion.

Dr. Morton, of London, has given us what, up to this time, may be held to be the most perfect form of ophthalmoscope. Recognizing the limitations of the single as well as of the double disk, he discarded both, and substituted for them a series of twenty-nine lenses, mounted separately in a metal ring or "shell," and arranged in such a manner that they just touch each other. (Fig. 16.) One ring is left without a lens, and the whole series of eighteen convex and eleven concave lenses forms an endless chain which is turned backward and forward with the greatest ease by the operator's finger, by a system of ratchet-wheels, to bring the right lens before the sight-hole and mark its strength at the same time on an index in numbers, white for concave and red for convex lenses. The advantage of this form of instrument is apparent. It allows the insertion of a practically unlimited number of lenses of larger diameter and thicker glass, and yet retains the simplicity of movement and indexing of the single disk.

A second disk is now added to Morton's ophthalmoscope, containing two minus lenses, of 10 and 30 D, and two plus lenses, of 0.5 and 20 D, for the sake of obtaining higher power and a larger number of combinations. For practical purposes these are not often necessary. The lower

FIG. 16.



ratehet-wheel has round perforations from one to eight millimetres in diameter, forming a convenient pupillometer.

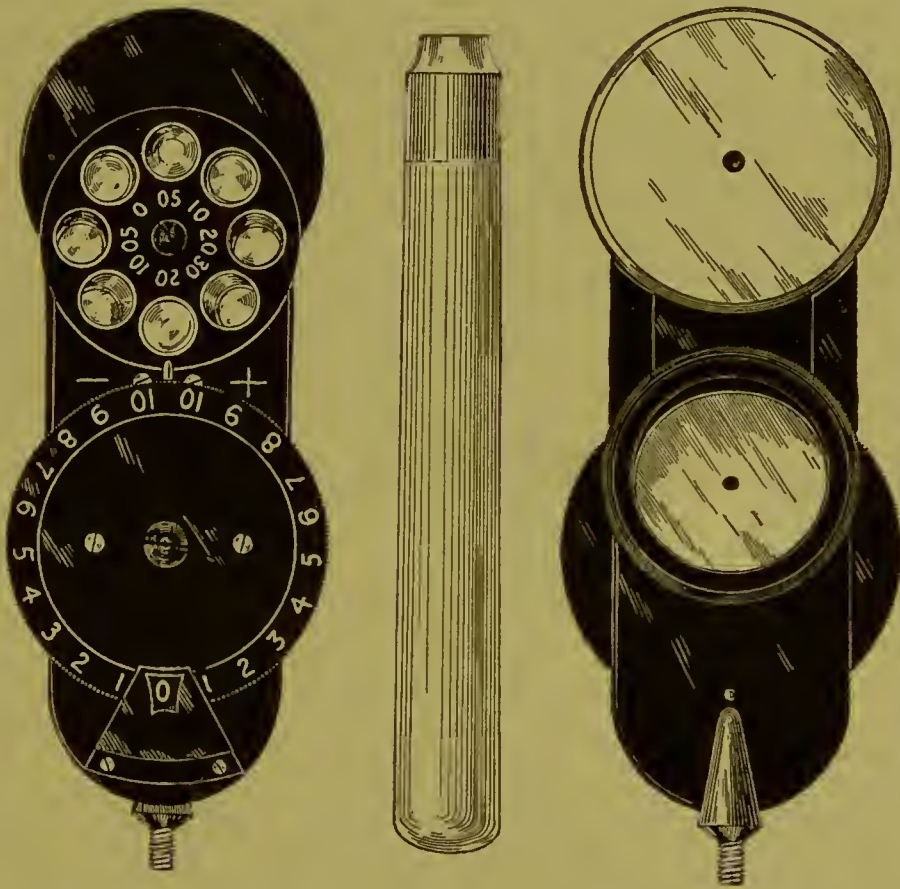
A modification of the Morton instrument (Fig. 17), very commendable as regards size and price, has recently been brought out in England by Hawes, of London. It contains a chain of lenses—ten minus and ten plus—giving all the whole diopters from one to ten; it has the secondary disk armed with  $+0.5$ ,  $+10$ , and  $+20$ , and  $-0.5$ ,  $-10$ ,  $-20$ , and  $-30$  diopters; it has a hinged attachment for both mirrors, and can be placed in a box three and a half by two and a half inches.

The art of illuminating and examining the interior of the living eye,—ophthalmoscopy,—like most other arts, has a practical and a theoretical aspect, and, as in those other arts, one may understand the theory without



being able to carry out the practical application, or, *vice versa*, he may be a good practical ophthalmoscopist and know little about the theory. It is, of course, unnecessary to urge the advisability of the inclusion of both parts in any complete curriculum of study. The laws of catoptries and of dioptries, upon which the art of ophthalmoscopy is based, are treated in the first volume of the System, and in the suggestions to be made a knowledge of them on the part of the reader is presupposed. It was the lack of such knowledge, or the lack of a simple, practical application of it,—probably the former,—that prevented men so long from understanding why the pupil is black when we look into it in the ordinary way, and also, of course, that pre-

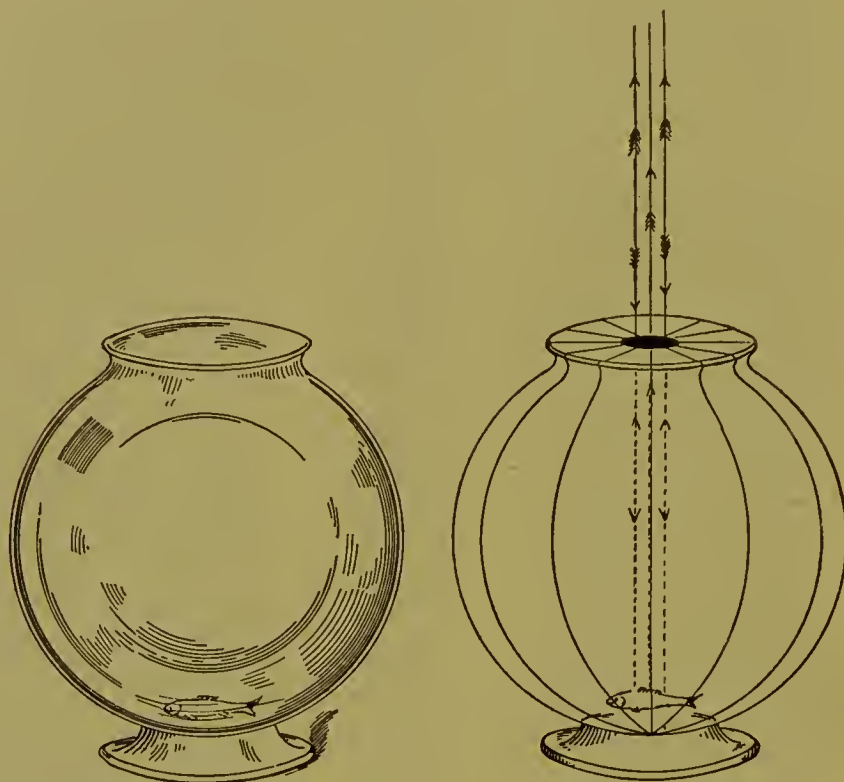
FIG. 17.



vented them from at once devising the ophthalmoscope. It had been supposed that the choroidal or retinal pigment absorbed the entering light; but only a slight experiment was required to convince one that there is no substance so "black" as to absorb all the impinging light and reflect none. All that was needed was a realization of the consequences of one of the primary laws of light,—namely, that it is partially reflected back from a non-transparent surface in such a direction that the angle of incidence is equal to the angle of reflection. If, for example, a glass globe containing a gold-fish is covered on all sides, except the top, with dark cloth (Fig. 18), one looking into it from above will see the fish plainly; if, however, the covering is advanced over the top equally from all sides, or from any one side, the view into the globe becomes less and less clear, until, when only

a circular opening one or two inches in diameter is left uncovered, the fish will have disappeared entirely from view, and the interior of the globe will appear black, although light enters it and light leaves it; the eye, when placed over it, will be either in the path of the light entering or in the path of the light leaving the globe; and as the rays that leave are those that have entered perpendicularly from above, and hence are reflected back

FIG. 18.



in the same direction, we can see why the observer's face must be always in the way.

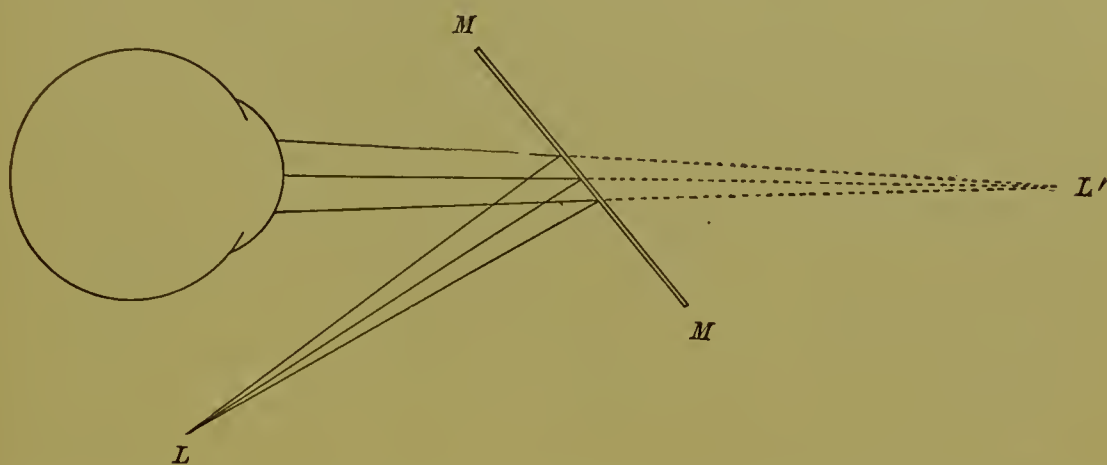
The human eye is a similar globe, with a small opening—the pupil—in front, through which the interior of the eye must usually appear black. If the observer manages to look closely along the direction of a ray of light entering the eye not quite perpendicularly, without obstructing its passage, he may catch a part of the returning ray, and will then see the fundus in its natural red color. But the light that enters the eye is made up of convergent rays which under normal conditions become divergent in leaving, and hence the observer's eye, when receiving some of the red glow, can see no more than a diffused circle of light, never a distinct image.

The first object of the ophthalmoscope, therefore, was to insure an arrangement that should throw a ray of light into a person's eye without having the observer's head in the way; the second was to catch the returning rays and modify them in such a way that the diffuse circle of light should be changed into a clear image in the observer's eye.

To attain the first object was a simple procedure after Helmholtz had shown the way. Any piece of smooth plane glass will do. Rays of light

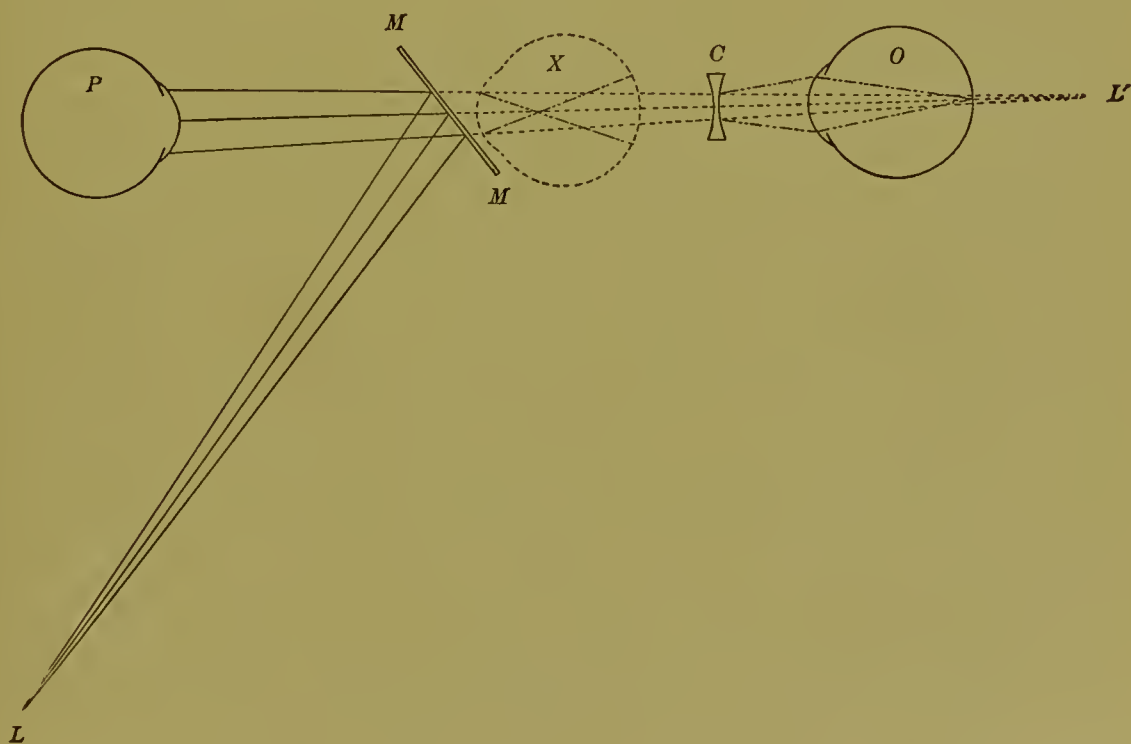
(Fig. 19) coming from  $L$  are thrown on the mirror  $MM$  and reflected into the eye; the fact that a large amount of the light passes through the mirror into space, and only a small amount is thrown into the eye, can be ignored as having no bearing upon the principle under discussion. The eye in this

FIG. 19.



wise receives a quantity of light coming apparently from  $L'$ , and, supposing the eye to be normal, the reflected rays leave the eye so convergent that they meet at  $L'$ . The observer's eye placed anywhere between  $MM$  and  $L'$  will see the red glowing pupil of the patient, but no more, because the

FIG. 20.

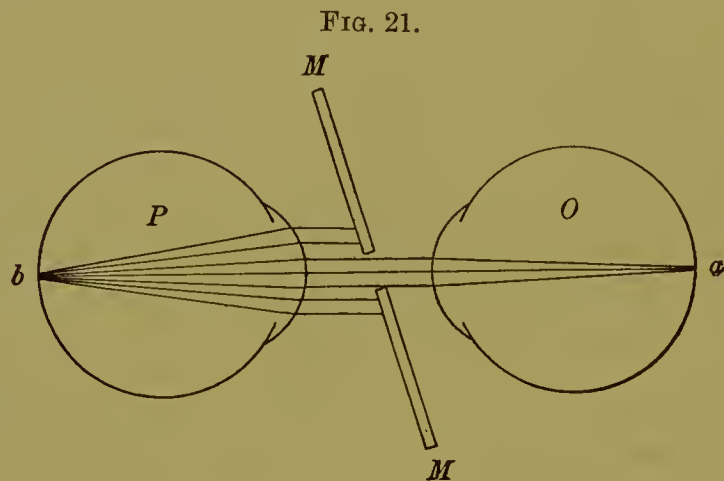


rays striking the eye when already convergent become more so on entering the observer's eye, and unite in front of the retina. ( $X$ , Fig. 20.) Helmholtz placed a concave lens,  $C$ , behind the mirror  $MM$ , in such a way that the convergent rays were made so divergent that when they entered the eye

and united the union took place on the retina, thus changing the diffuse red glare into a clear and distinct image, and the observer's eye, *O*, was able to examine the well-illuminated fundus of the patient's eye, *P*.

To increase the rather weak illumination obtainable by the plane glass, a silvered plane mirror with a central opening in the silvering was substituted; and later a concave silvered mirror with a hole drilled through the centre.

But the fundus of the eye can be examined without the aid of a concave glass, if the rays (Fig. 21) reflected from a plane mirror into an eye are made to strike the cornea parallel, by holding the mirror as close to the eye as possible without interfering with the illumination; then these rays are brought to a focus on the retina at *b*, if the eye is emmetropic. As



they are reflected out they are again parallel when leaving the eye, and will strike in a parallel direction another eye placed close behind the perforation in the mirror; and, supposing this eye to be also emmetropic, the rays will be brought to a focus on the observer's retina at *a*, and the latter will see a clear image of the patient's eye-ground, provided both have relaxed their accommodation and are adapted to distant vision.

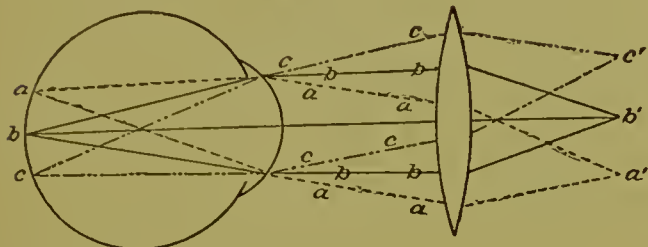
This form of ophthalmoscopy is called the "direct" method, and gives to the observer a magnified erect image of a limited area of the fundus. If the eye to be examined is myopic,—*i.e.*, if the focus is in front of the retina,—a concave glass equal to the ametropia must be placed behind the mirror; if hypermetropic, a convex glass of equal power must be used. The observer's eye is under all conditions supposed to be emmetropic, and if not so naturally, the proper glasses must be used to correct the existing error. With the observer's eye in normal condition and with relaxed accommodation, the spherical lens necessary to give a clear image represents approximately the error of refraction in the eye examined.

The "indirect" method allows the examination of a larger part of the fundus, but does not magnify the image as highly as the "direct" method; it may be explained as follows:

Every part of the fundus located in the focus of the refracting media

of the eye sends out rays of light that are parallel after they leave the cornea. (Fig. 22.) Thus, from *a*, there leave *aa* and *aa*; from *b*, *bb* and *bb*; from *c*, *cc* and *cc*, etc. A convex lens placed in the path of

FIG. 22.



these rays will gather *cc* and *cc* at *c'*; *bb* and *bb* at *b'*; *aa* and *aa* at *a'*, producing at *c'b'a'* a somewhat enlarged "inverted" picture of *abc*, which the eye looking through the opening of the mirror can plainly see, provided

all the rays have been properly brought to a focus,—*i.e.*, if the convex lens is held at the proper distance before the eye and the observer's accommodation has been thoroughly relaxed. For this method of examination a concave mirror is used in most cases in order to concentrate the light better.

We thus have five methods of examining the eye: 1, without instruments and by the aid of ordinary daylight; 2, by the aid of the ophthalmoscopic mirror alone; 3, by oblique illumination, either with or without the magnification by a second convex lens; 4, by the indirect method; 5, by the direct method. The first three methods enable us to examine the anterior parts of the eye, the so-called *tutamina oculi*, or the defensive and protective portions of the lids, eyelashes, etc., the conjunctiva, cornea, anterior chamber, iris, pupil, and the anterior capsule of the lens; and in case lenticular and vitreous opacities exist, these may also be seen by one or more of these methods. By means of the last two methods—ophthalmoscopy proper—we examine the retinal and choroidal structures or lesions.

In the routine clinical examination of a patient's eyes we should use each method *seriatim*. Each supplements the other, and by one may be revealed some abnormality that the other would not show. By the naked eye alone the general condition of the anterior structures is made manifest, and any considerable departure from normality, such as strabismus, blepharitis, corneal leucomata, shallowness of the anterior chamber, immobility or occlusion of the pupil, cataract, etc., is roughly diagnosed.

After we have thus examined the eyes, we have to decide whether or not we shall use a mydriatic before proceeding with the examination by the aid of instruments. This decision will be governed by many considerations: the leisure of the patient, the purpose of the examination, the expertness of the physician, the probable nature of the malady, etc.

If we conclude to paralyze the iris, we must not do so until we have examined the pupillary movements and made notes of the findings. The pupillary examination is often more important than that of the rest of the eye, especially in diseases of the cord and brain.

In patients over fifty years of age we do not really need to use a mydriatic in order to diagnose the existing errors of refraction, and in such

cases, therefore, we shall rarely need to widen the pupil for purposes of ophthalmoscopy. There are also other conditions in which the mydriatic is useless or contra-indicated, if we are expert enough with the ophthalmoscope to make a satisfactory examination of the eye-ground without it. This expertness it is highly desirable to obtain. Without a mydriatic, however, it is often extremely difficult and even impossible to make a satisfactory examination of the macula region. For this and other reasons this region is not commonly inspected, although it is of course one of the most important parts of the eye-ground, if not absolutely the most important. If we find it impossible to make the accurate examination we desire without mydriasis, and if at the same time there is no other need for a mydriatic than for purposes of ophthalmoscopy, we may use a weak solution of homatropin. One or two instillations of such a solution will in a short time keep the iris out of our way, and the consequent paralysis of accommodation is slight, or will last, at longest, for but a few hours. In those cases in which we wish to estimate refractive errors, or in which we wish to use the mydriatic as a therapeutic measure, we will of course use either atropin or a stronger solution of homatropin. I have found that a half-dozen instillations during an hour of a solution of homatropin of a strength of ten grains to the ounce, combined with cocain of the same strength, almost always gives mydriasis sufficiently reliable to insure correct refraction work, and the paralysis of the accommodation passes away in from twenty to thirty hours.

The value of the method by the ophthalmoscopic mirror alone is chiefly to reveal opacities of the transparent media of the eye, and especially to manifest the existence of incipient cataract. By reflecting the light in sideways, above, or below, effected by changes of position of the surgeon or by instructing the patient to rotate the eye, we are able to examine the peripheral portions of the lens and detect the beginnings of cataract in these parts. The weak illumination at the peripheral parts of the retina does not arouse such energetic contractions of the iris and pupil as does the stronger central illumination, and by dexterity we are able to see the extreme radial parts of the lens in a non-mydriaticized eye. Opacities in the vitreous humor are also to be detected by means of the mirror alone, especially in mydriasis, and can be proved stationary or "floating" by a change in position either of the physician or of the patient. If floating, we may, as it were, give them a fillip or "ocular ballottement," as I have named it, by asking the patient to look upward and suddenly again straight in front, when the dark particles, having been thrown upward by the motion, will be seen to float or settle downward again to the lower parts of the vitreous chamber.

The examination by oblique illumination is carried out by bringing to a focus upon the cornea, etc., the rays of a strong artificial light by means of a lens of two or three inches' focal length. (Fig. 23.) The structures thus brilliantly illuminated may, if desirable, be examined more accurately and

closely by the aid of a second lens held in the other hand. By this method we may detect all pathologic conditions of the cornea, anterior chamber, iris, and anterior portions of the lens, such as corneal leucomata, onyx, hypopyon, ulcers, opacities or foreign bodies in the anterior chamber, anterior and posterior synechiæ, occlusion of the pupil, anterior polar cataract, etc. By this method also it is determined whether the reactions of the iris, the size of the pupil, etc., are normal or abnormal.

A convenient method of locating several opacities, or of determining the number present, is that suggested by Professor Fuchs. This is by

means of what he calls their parallaxic movement. For example, the observer's eye at *A* (Fig. 24) will see the four opacities as one; with the patient's eye remaining fixed and the observer's eye moved over to *B*, the one spot will resolve itself into four distinct points, 1, 2, 3, and 4. The same parallaxic movement helps to localize the opacities. Any opacity situated, say, in the centre of the pupil, on or near the anterior part of the

FIG. 23.

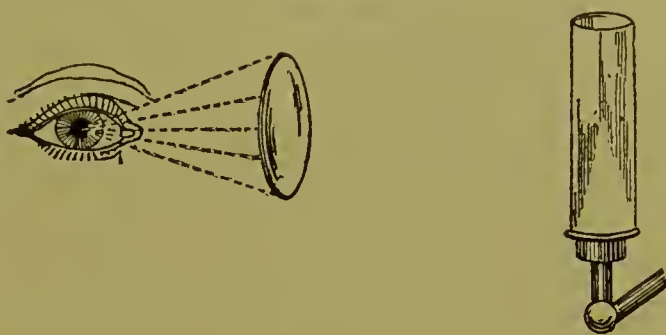
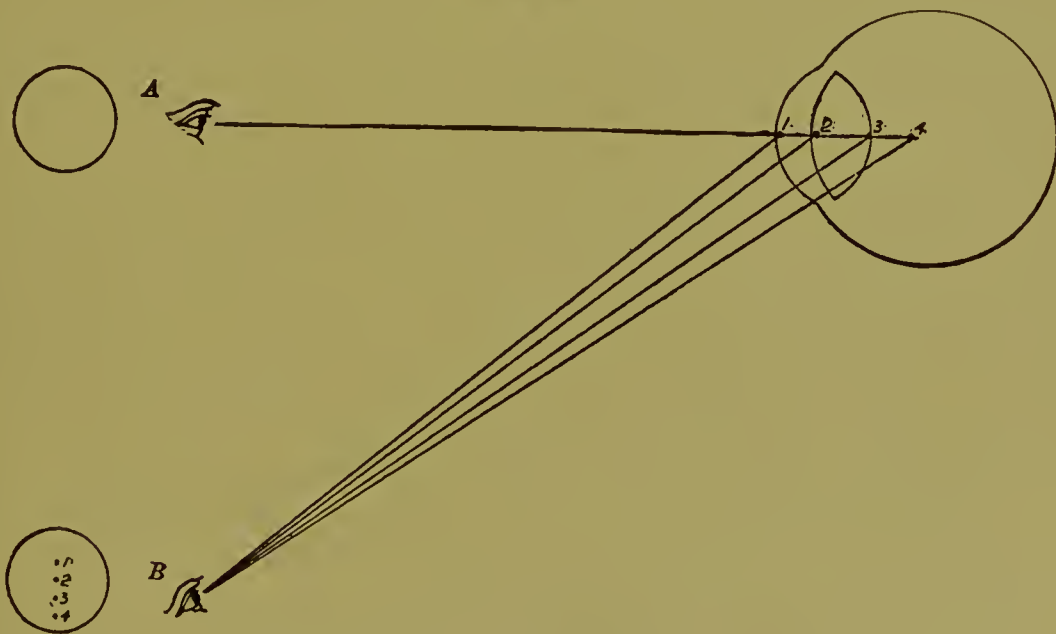


FIG. 24.



lens, will retain its position at 2, no matter whether the eye views it frontwise or sidewise; if, on the other hand, *a*, *c*, and *d*, which seemed to occupy the centre of the pupil with the observer in front, are looked at sidewise, they each change position in a definite way: the opacity at 1 travels in a direction opposite to that taken by the observer's eye over to the margin of the pupil,—*i.e.*, it is situated in front of the lens; the other two take the same direction as the observer and travel over to the opposite margin of

the pupil,—they are situated behind the anterior surface of the lens,—and the more rapidly they travel the farther back in the eye the opacity is located.

When the crystalline lens is normal, and especially in the young, its presence cannot be demonstrated by the ophthalmoscope, but with oblique illumination light-reflexes can be obtained from the anterior as well as from the posterior surface. Care not to mistake this reflex must be exercised in this form of examination, because at times the strong light will give to the lens a grayish appearance, a slight opacity that may suggest the beginning of cataract, especially if the patient be of the cataract age. In old people the anterior capsule increases in opalescence, which is in a sense physiologic, and which at least is not cataract.

Ophthalmoscopy by the indirect method requires the twelve-inch ophthalmoscopic mirror and a condensation lens (or biconvex lens) of about two-inch focal power. The light is placed a little behind the head and a little towards the side of the eye to be examined. A simple rule, of service, at least to beginners, by either method of ophthalmoscopy, is that the rays from behind shall strike the eyelashes on the temporal side of the eye to be examined, without illuminating the cornea. The patient directs his gaze in front, while the physician stands a little to the side. Holding the mirror in his right hand, close to his own right eye and about a foot from that of the patient, the observer, looking through the aperture of the mirror, reflects the light into the pupil, and the roseate glow of the fundus appears. The lens, held between the thumb and the index finger of the left hand (the little finger resting on the patient's forehead or temple), is now interposed in the path of the illuminating rays, and at a distance of two or three inches from the observed eye. The rays returning from the fundus are thus brought to a focus between the observer's eye and the lens, and an aerial image is formed of a large portion of the eye-ground. More peripherally lying portions of the fundus are brought into view by directing that the eye be moved laterally, vertically, etc. To examine the left eye the patient is directed to look to the left of the physician, thus avoiding a change of position either of the light or of the patient's body.

The chief advantage of this method of ophthalmoscopy lies in the fact that a larger area is observed at one glance than by the direct method. We see the fundus, as it were, almost as a whole. The magnification is about five or six diameters, varying according to the strength of lens used, while that of the direct method is from sixteen to eighteen diameters. The close proximity of face to face required by the direct method is also avoided by the indirect method, a thing that is sometimes desirable.

The chief disadvantage of the indirect method as compared with the direct is that it gives a much more poorly defined image, the sharp details and more intimate nature of lesions not being clearly brought out. While it may be used sometimes when the other method is not so available, diagnoses made by it must be more rough, general, and doubtful.



The direct method of ophthalmoscopic examination is carried out by means of the modern ophthalmoscope alone, and will always be relied upon to give the more accurate reports of the condition of the living eye itself and of the indications of systemic conditions to be gained from the ocular state. It is practised by means of the light placed as in the indirect method, relatively to the patient and physician. If the physician is taller than the patient, considerable time and trouble will be spared by making the examinations with both standing. The light must be a steady, clear, white-light flame. To examine the right eye, use the right hand, tilt or turn the mirror so that its surface shall be at right angles to the impinging light, and place the instrument close to the observer's eye. Standing about a foot away, fix the patient's gaze in a direction forward, so that his axis of vision and that of the physician shall form an angle of about fifteen degrees, and reflect the light into the pupil of the observed eye. When the fundus-glow appears, keep it in view while advancing rapidly until within an inch or less of the observed eye. It is well to warn beginners in the use of this method to imagine that they are looking at an object a foot or more away, thus not arousing accommodative effort. If the observer have a considerable error of refraction, this must be neutralized by bringing one of the lenses of the Reikoss disk into position. If the patient have an error of refraction, it must be neutralized as nearly as possible in the same way, in order to bring out sharply all details of the fundus. In this way, indeed, may be roughly estimated the kind and the degree of the patient's error. For this purpose the papilla is not the proper object upon which to fix the attention, because this may not be of the same level as the retina. The best objects for this purpose are the finest capillaries or the delicate structural peculiarities of the retina or choroid in the neighborhood of the macula region.

To examine different parts of the fundus requires a synchronous adjustment and direction of the light-reflex and of the gaze to the part desired. It is well also to use the left hand upon the back of the patient's head to hold it in position and to move the head, in order to keep the light reflected in the direction desired.

To examine the left eye the instrument is held in the left hand, and the relative positions of the light, the physician, and the patient are correspondingly changed.

If the refracting media of the eye are normal, they are transparent and invisible when we examine the eye-ground with the ophthalmoscope. If either cornea, aqueous humor, crystalline lens, vitreous humor, or retina become visible, we have to deal with pathologic conditions. There is, perhaps, no problem more puzzling to the young ophthalmologist than that of deciding whether the peculiarities of an observed eye-ground are physiologic or pathologic. The normal or physiologic differences are so infinite in variety and extent that any attempt to describe them would be absurd. The expert eye and judgment recognize at a glance a peculiarity as physiologic that is glaring and astonishing in its anomalousness and boldness, and

it is only after years of practice and a peculiar sensitiveness of personality and perception that even they recognize some trifling, almost invisible, flecking or evidence of morbidity that reaches to brain, heart, or kidney for its origin, and the ocular warning of which, thus early thrown out and early recognized, may mean the saving of the patient's life.

No two ophthalmoscopic pictures are alike, every one being as different from every other as are faces. This gives perennial interest to the work of the ophthalmoscopist. Just as the student of psychology finds in every physiognomy a new expression of the infinitely subtle and variant life within and behind all faces, so in every eye-ground the ophthalmoscopist finds something new that challenges interest and inquiry. This, as I have said, is true even of eye-grounds the differences of which are normal or physiologic; but when there are added the variations that are pathologic in origin, the interest of the physician is more than doubled.

Congenital anomalies must also be distinguished, in order that they may not be confounded with acute pathologic abnormalities and thus lead to errors in diagnosis.

Perhaps the most commonly encountered condition of this class is that of opaque nerve-fibres. As the light has to penetrate the nerve-fibre layer of the retina in order to reach the rods and cones,—the ultimate organs intermediating the transformation of ethereal vibrations into neural vibrations,—it is evident that this stratum must be highly transparent. In the optic nerve each fibre of the several hundred thousand is insulated from its neighbors by an encasing material called the white substance of Schwann. This myeline sheath is normally not continued beyond the entrance of the fibres into the globe, but when it is so continued the extension upon the retina becomes ophthalmoscopically brilliantly manifest, and the "opaque nerve-fibres" are seen as feather-edged, somewhat flame-shaped or cloud-like, opaque white striated patches, continuous with the papilla, extending from it outward upon the retina in the direction of the course of the fibres for variable distances, and of ever-varying forms. The fact serves to increase the area of the "blind spot," normally limited to that of the papilla; but I have not observed any inconvenience from this to the patient, however extended the region of the retina thus invaded. The condition is sometimes liable to be mistaken for albuminuric retinitis, posterior staphyloma, or an enlarged coccus.

Noteworthy "cupping of the disk" is not infrequent, and may closely simulate the early stages of the pathologic or atrophic excavation due to glaucoma; it is, however, not so deep nor so broad as the glaucomatous variety. At the bottom of the cupping a mesh-work of fibres called the *lamina cribrosa* is to be seen when brought into focus by the proper lens of the ophthalmoscope. The vessels curl over the edge of the depression, where they show darker because looked at along the line of flexure, are sometimes temporarily lost to view as they cling to the sides, and reappear again upon the floor of the excavation.

Coloboma of the choroid is more rarely met with, but presents a striking object. It is due to a developmental fault, and at the same time may extend to one or more other structures of the eye, such as the optic disk, retina, ciliary body, lens, or iris. The rent or absence of the pigmented structures of the fundus permits an unimpeded view of the white sclerotic, which thus boldly stands out as a sharply defined, dead-white patch, usually in the lower part of the fundus, of varying area and shape, traversed by the choroidal and ciliary vessels, and, if the retina does not participate in the anomaly, by those of the retina. Sometimes in the white space there are pigment heapings or other color-changes.

Persistence of the hyaloid artery, or rather of remnants of it, also occurs in a very small proportion of cases.

The fundus of the eye of the albino offers a congenital abnormality of peculiar and pathetic interest. The failure in the secretion of the ocular pigment is of the same mysterious nature as that of the skin, the hair, etc. The iris is affected in the same way, the iris-defect, in my opinion, constituting the chief source of origin of the sufferings of the albino. The light shines through the iris, thus preventing its chief function, viewed as a camera, of sharp definition and focalization of the image upon the retina, with resultant amblyopia and photophobia. The eyeball is rotated and vibrated from side to side, vainly seeking a more clearly defined, shade-bordered image, thus inducing nystagmus. The lids seek to replace the lost function of the iris, and this spasmodic crushing of the globe produces high degrees of astigmatism and other forms of ametropia. Ophthalmoscopically, the albinotic fundus is but a more accentuated form of the same picture seen in the eye of a pronounced blonde. The pinkish pallor and transparency of the background permit the tracery of the choroidal vessels to be plainly seen, while the retinal vessels stand out with remarkable clearness.

With the ever-varying pigmentation of the retina, extending from the entire lack of it in the albino to the black rippled or densely stippled darkness of the negro, we pass from the question of positive abnormalism to variations that are simply physiologic. The rich, rosy, glowing hue of the eye-ground is due to reflection of the light from the choroidal capillaries and their contained blood, modified, of course, by the general degree of pigmentation.

The most striking object of the normal fundus is the disk, or papilla, sometimes also called the nerve-head. It is the intra-ocular ending of the optic nerve, and is really about one and three-quarters millimetres in diameter, appearing by the direct method about sixteen times its actual size. Its whiteness, usually more pronounced at the temporal side, is due to the myeline sheathing of the fibres, which is discontinued at the papilla border, the fibrils there becoming transparent. The slightly pinkish hue is due principally to the capillaries supplying it with blood. The disk is situated a little to the nasal side of the vitreous chamber, and is usually circular in

form, though occasionally somewhat oval, with the long diameter in the vertical axis. High degrees of astigmatism produce apparent abnormalities of form, according to the type of the astigmatic defect, and high degrees of hypermetropia and of myopia produce the corresponding appearance respectively of an abnormal smallness or largeness of its diameter.

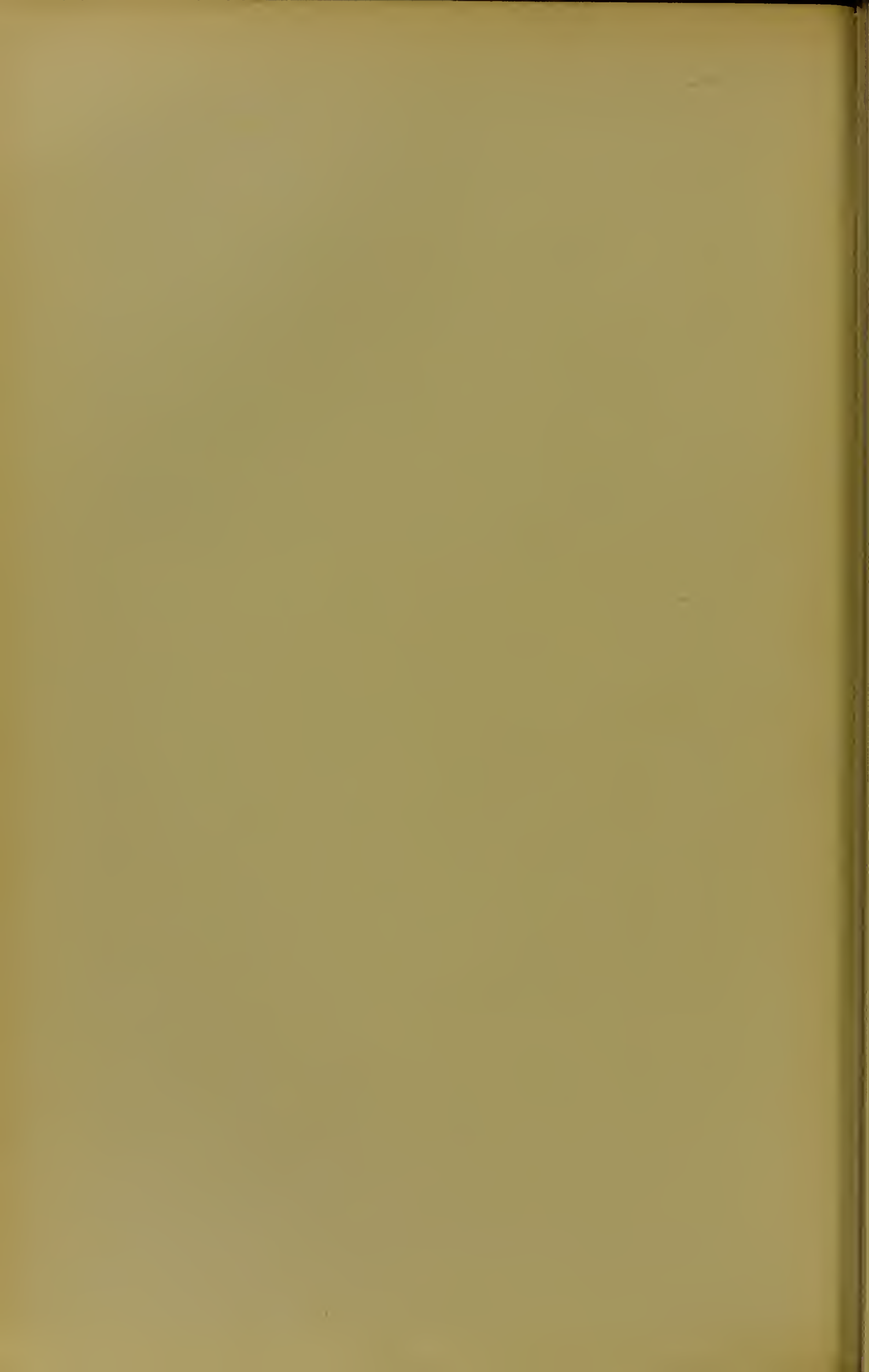
The disk is usually surrounded by a tiny marginal ring, sometimes pigmented, and called the scleral or connective-tissue ring, formed by a partial or complete opening of the choroid, which allows a ring of sclerotic tissue to shine through. At the margin of this ring is usually another ring-like pigmentation of the choroidal edge, called the choroidal ring. These rings must not be confounded with the pathologic conditions called conus, myopic crescent, posterior staphyloma, etc.

From the central depression of the papilla rise the branches of the central artery of the retina, spreading in their subdivisions towards all the parts of the retina, and to it also converge the veins. These vessels by direct ophthalmoscopy seem to be so large that we can hardly realize that they are in reality only from two-fifths to three-fifths of a millimetre in diameter. The arteries are lighter in color and more tortuous than the veins, are about one-third smaller, and usually pass over the veins. The central white streak or line of light-reflex from them is more marked and more regular than in the veins. The arteries often pass spirally around the veins once, or even twice, near the disk. As the veins dip down over the edge of the cup of the disk, a distinct pulsatory movement is frequently seen at this point synchronous with the cardiac beat. This phenomenon—the venous pulsation—is physiologic, and should not be confounded with the rare pathologic pulsation of the arteries in the same position. The division of the main central artery into two branches, the superior and the inferior, usually occurs before its emergence upon the papilla, and these two principal trunks undergo dichotomous subdivision into temporal and nasal branches, and others, as they progress towards the peripheral parts of the retina. Corresponding coalescences of the peripheral capillaries of the veins occur in approaching the disk, until all unite in the two chief trunks that enter the optic nerve by the side of the arteries. Sometimes the central artery of the optic nerve may subdivide after its exposure upon the disk, or the superior and inferior branches of the vein may unite before disappearing from view.

Although not by any means so striking an object as the disk, the macula is, as regards the eye, *per se* the most important region of the fundus. It lies about a disk-diameter, or two millimetres, from the disk, temporally, and is recognized only by a slightly darker tint than the adjacent retina, and by an entire absence of larger vessels and the disappearance of the small capillaries at this point. It was called the yellow spot by the early anatomists, who saw it after death only. In life its tint as seen by the ophthalmoscope is not yellowish, but is only a little more deeply pigmented than the rest of the retina. The size of the macula varies con-

siderably, if this somewhat indeterminate region can properly be termed measurable, but it is commonly slightly larger than the disk, somewhat oval, with the long diameter horizontal. It is sometimes, and especially in the young, surrounded by a "halo," or shimmering ring of light, due to a reflection from the slight depression or compression of the retinal elements which constitute the macula and fovea. In the centre of this region is the pit or depression called the *fovea centralis*, often almost or quite invisible, sometimes seen as a tiny spot of lighter, glittering coloration. The fovea is the point of retinal contact of the visual axis, and constitutes the retinal intermediary of the most minute and perfect vision. Here the less essential or contributory elements are reduced to their lowest number, and the essential ones, the rods and cones, are packed into closest proximity.

In children there is sometimes seen a shimmering, ill-defined, glittering reflex, glancing along the vessels and over the fundus with the movements of the ophthalmoscopic mirror. It is certainly not pathologic. For obvious reasons, it has been called the watered-silk or shot-silk phenomenon. Its cause has not been definitely ascertained.



# SKIASCOPY (THE SHADOW-TEST, RETINOSCOPY) AND ITS PRACTICAL APPLICATION.

BY EDWARD JACKSON, A.M., M.D.,

Professor of Diseases of the Eye in the Philadelphia Polyclinic; Special Lecturer on Physiological Optics in the University of Colorado, Denver, Colorado, U.S.A.

---

## OPTICAL PRINCIPLES.

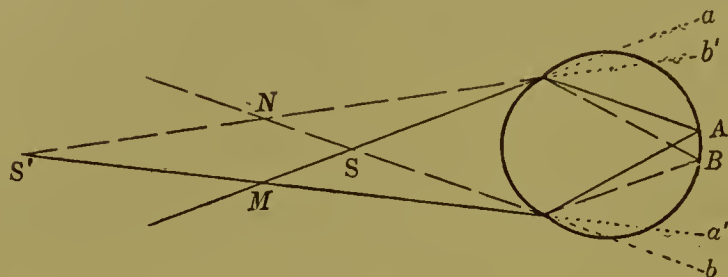
THE theory of the ophthalmoscope as originally worked out by Helmholtz recognized the relation of direct and inverted images of the fundus, and the seeing of an erect or an inverted image when the eye was looked at from some little distance, without the intervention of a lens, has from the first been ranked among the important signs of hyperopia or myopia in the ophthalmoscopic examination. The direct method of ophthalmoscopy deals with an erect enlarged image of the fundus, apparently situated behind the eye, such an image as is obtained with the simple microscope, the ordinary magnifying glass. The indirect method, on the other hand, works with an inverted image of the fundus formed in front of the eye, either by the dioptric media alone, as in high myopia, or by a strong convex lens placed before the eye, as in other states of refraction. In the highly myopic eye an erect image can be seen if the observer place his eye close enough to the observed eye, although this image will be indistinct unless the light from it be made to focus on the observer's retina by the use of the appropriate concave lens.

*Reversal of the Image.*—In any eye, therefore, the use of the ophthalmoscope at short enough distance reveals an erect image of the fundus, and in any eye from a greater distance one may obtain an inverted image by reason of its own myopic refraction, or by the artificial myopia effected by the use of a convex lens.

This is illustrated by Fig. 1. The direction in which a certain portion of the fundus appears to be located is determined by the direction in which a ray from it falls upon the nodal point of the observer's eye. In the figure let *A* and *B* represent points upon the retina of the patient, and *M* and *N* points outside of the eye from which the rays would be focussed upon *A* and *B*, or to which the rays from *A* and *B* are focussed as they pass outward. When the surgeon places his eye with its nodal point at *S*, the ray which reaches that nodal point from *A* is one that passes through the upper part

of the pupil and is turned downward: hence from this position the point  $A$  of the retina will appear to be situated in the direction of  $a$ , in the upper part of the pupil. The ray which reaches the nodal point from  $B$  is one which passes through the lower part of the pupil and is turned upward:

FIG. 1.



hence  $B$  appears to be situated at the lower part of the pupil in the direction  $b$ . That is, comparing the two points  $A$  and  $B$ , the one which is really above appears to be above, and the one which is really below appears to be below. The retina is then seen in the erect image.

If now the surgeon places his eye beyond the distance of  $M$  and  $N$  for which the patient's eye is focussed, say with his nodal point at  $S'$ , the ray which reaches his nodal point from the point  $A$  is now one which passes through the lower part of the pupil and is turned upward, so that the point  $A$  appears to be situated in the lower part of the pupil at  $a'$ . On the other hand, the ray coming from  $B$  to his nodal point is one passing through the upper part of the pupil and being turned down, so that  $B$  now appears at the upper part of the pupil in the direction of  $b'$ . That is, the point which is really higher on the retina appears at the lower part of the pupil, and the lower point at the upper part of the pupil. The retina is seen in the inverted image.

Another way to think of this matter, less analytic but perhaps easier to understand, is, that when the surgeon is closer to the eye than  $M$  and  $N$  he sees an erect image back of the eye, but when he gets beyond  $M$  and  $N$  he has to look at the inverted image which is formed at  $M$  and  $N$ .

The point at which the change from the erect to the inverted image occurs is the point for which the eye is focussed, either by its own refraction or by that of the lens before it,—the conjugate focus of the retina,—the far-point for the myopia, natural or artificial. To know the distance of this point from the eye is to know the focal distance of the lens which will correct the myopia, and, therefore, to know the error of refraction present.

Skiascopy furnishes us a ready and accurate means of determining the location of this point where the change from the erect to the inverted image occurs,—this point which I have termed *the point of reversal*.

*Movement of Light on the Retina.*—If one attempts to locate the point of reversal by the ordinary ophthalmoscopic examination, he finds that as it is approached the images of the fundus become diffuse and indistinct, so that for a considerable distance on either side of this point it is impossible to determine whether the image seen is erect or inverted.

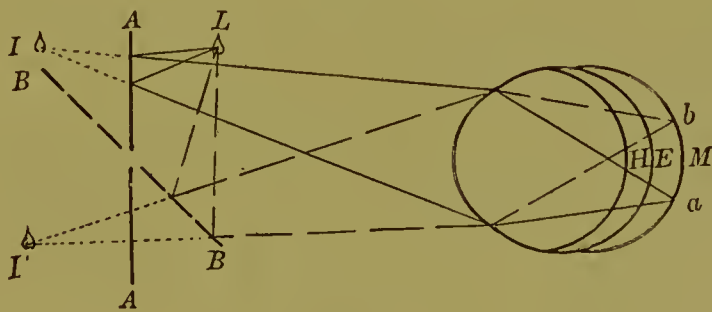


Skiascopy avoids all attempt to see any details of the fundus of the eye distinctly, and indicates whether the image is erect or inverted simply by the direction of the movement of light and shade in the pupil. If the light on the retina removes from *A* to *B*, it will appear to move upward when the image is erect, downward when it is inverted; so that if one knows in which direction it really moves, he has only to observe the direction of its apparent movement in the pupil to determine whether it is an erect or an inverted image that he sees, and, by making the test at various distances, he can determine where the change from the erect to the inverted image occurs, and measure the distance of this point from the eye.

The movement that is to be watched is the apparent movement of an area of light on the retina. This movement is brought about by changing the angle of the ophthalmoscopic mirror (usually a special form adapted to skiascopy), so that light falling on it at different angles is reflected into the eye from slightly different directions. This movement was early employed by Bowman for the detection of irregular astigmatism.<sup>1</sup> He also pointed out that it frequently revealed the presence of regular astigmatism and the direction of its chief meridians.<sup>2</sup> The recognition that this manœuvre was capable of development into a distinct method for the measurement of refraction, of universal application and great practical value, is due to Cuignet.

How the change in the direction of the mirror affects the movement of the light upon the retina may be understood by reference to Fig. 2, in which

FIG. 2



the action of a plane mirror is represented. *L* is the position of the light. The mirror being in the position of *AA*, the light reflected from it, in accordance with the laws governing the reflection of light, will diverge as though starting from a point *I*, as far behind the mirror as *L* is in front of it, and in the same perpendicular to its surface. From the direction of *I* the light is converged within the eye towards *a*, and falls upon that portion of the retina. If, however, the position of the mirror be changed to *BB*, the line passing through *L* perpendicular to the mirror undergoes a similar change, and, therefore, *I'*, the point from which the rays appear to diverge after they have been reflected by the mirror, is considerably removed from the

<sup>1</sup> Royal London Ophthalmic Hospital Reports for 1862, p. 157.

<sup>2</sup> Donders, Accommodation and Refraction of the Eye, p. 490.

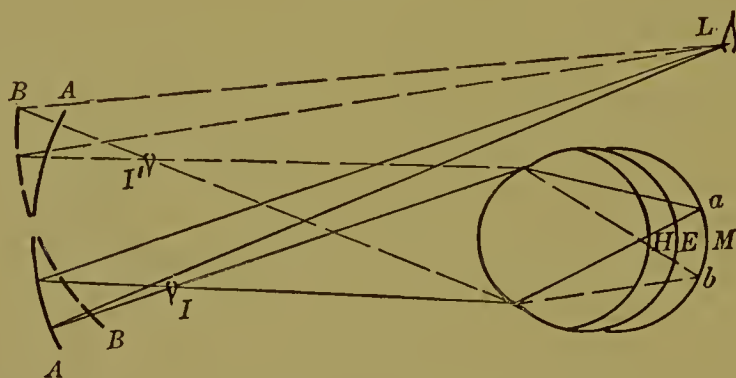
point  $I$ , and the rays coming from it focus in the eye towards  $b$ , and fall upon that portion of the retina.

As the mirror turns from  $AA$  to  $BB$ , the area of light upon the retina moves from  $a$  to  $b$ . Calling  $L$ , the lamp flame, the *original source* of light,  $I$ , or  $I'$ , the point from which the rays at the time appear to proceed, may be called the *immediate source* of light. The original source of light being fixed, the position of the immediate source will vary with the direction of the mirror, and the position of the light area on the retina will vary to correspond with it. When the light is thrown on the eye with the skiascopic mirror, a portion of it enters the pupil to form the *retinal light area*, but the greater part falls upon the face, and, as the direction of the mirror is changed, the position of this *light area on the face* is also changed.

It is evident that as the mirror is changed from  $AA$  to  $BB$ , the light area on the face moves upward in the same direction as the light area on the retina. Hence, *with the plane mirror the real movement of light on the retina is always with the light on the face, or with the movement of the mirror*, and this applies equally to hyperopia, emmetropia, and myopia, as can readily be understood by looking at the lines  $H$ ,  $E$ , and  $M$ , which represent positions of the retina in these different states of refraction.

When the *concave mirror* is employed, the movement of the light on the retina is in the opposite direction. The reason of this may be understood from Fig. 3, in which, with the original source of light at  $L$ , and the mirror

FIG. 3.



in the position  $AA$ , the immediate source of light will be  $I$ , to which all the rays falling on the mirror from  $L$  are converged. Evidently  $I$  is a focus of the mirror conjugate to  $L$ , and from this point  $I$  the rays diverge to be focussed towards  $a$ , and to fall upon that portion of the retina. If now the position of the mirror be changed to  $BB$ , the immediate source of light (the focus conjugate to  $L$ ) changes its position to  $I'$ , and from  $I'$  the rays enter the eye to be converged towards  $b$ , and to fall upon that portion of the retina. With the change of the direction of the mirror from  $AA$  to  $BB$ , the immediate source of light moves from  $I$  to  $I'$ , and the area of light on the retina moves from  $a$  to  $b$ , and this occurs whether the eye be hyperopic, emmetropic, or myopic, as represented by the lines  $H$ ,  $E$ , and  $M$ . In this case the change of direction of the mirror has been the same, and it will be found that the

change in the position of the area of light on the face has been the same as in a former case, but that the movement of the light on the retina has been in the opposite direction. Hence, with *the concave mirror, the real movement of light on the retina is in the direction opposite to that of the movement of light on the face, is against the movement of the mirror*, and this applies for all states of refraction.

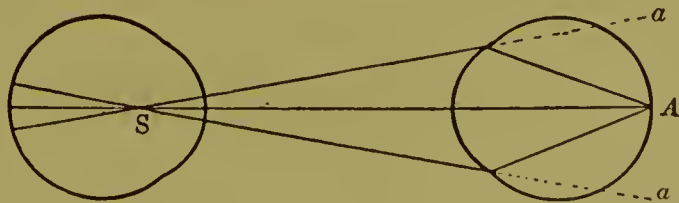
*Apparent Movement of Light in the Pupil.*—We thus, whichever mirror is employed, know the real direction of the movement of the light area on the retina, and, watching its apparent movement in the pupil, are able to determine whether the image seen is erect or inverted. In the *erect image* the apparent movement will correspond with the real,—*with the light on the face for the plane mirror, against it for the concave.* In the *inverted image* the apparent movement will be the opposite of the real movement,—*against the light on the face for the plane mirror, with the light on the face for the concave.* By determining the point where the movement changes from direct to inverted, we determine the point of reversal and the refraction of the eye.

*Rapidity of Movement of Light in the Pupil.*—In making application of the test, it is frequently convenient, before the point of reversal has been ascertained, to be able to estimate approximately how near we are to it, and how great a change of glass will be necessary to bring it into the desired position. This estimate is to be based upon the rapidity of the apparent movement of light in the pupil, and also upon the brilliancy of this light; but principally upon the former.

The apparent rapidity of movement of light in the pupil depends on the real rate of movement of the light on the retina, and on the extent to which this is magnified by the magnification of the retina. The real rate of movement on the retina depends on the rapidity of movement of the mirror, on the distance of the source of light from the mirror, and on the distance of the mirror from the eye. But with the same observer working under the same conditions, these distances will be tolerably uniform, so that differences of apparent movement will depend principally on differences of the magnification of the portion of the retina seen in the pupil.

When the nodal point of the surgeon's eye is situated at the point of reversal (the focus conjugate to the position of the retina), rays coming from

FIG. 4.



a single point of the retina reach this nodal point from all parts of the pupil. This is illustrated by Fig. 4, in which the surgeon's eye with its nodal point at *S* receives rays from a point *A* on the patient's retina. These rays coming

through every part of the pupil, the single point *A* of the retina appears to occupy the whole area of the pupil, *aa*.

As the nodal point of the surgeon's eye is moved away from the point of reversal, rays reach it from more than one point of the patient's retina, as seen in Fig. 1; and the farther the eye is withdrawn from the point of reversal the larger the portion of retina seen in the patient's pupil at one time, and, therefore, the less magnified is this image of the retina, whether erect or inverted. Since the rapidity of the apparent movement depends on the degree of magnification of the image seen, the more nearly the point of reversal is approached the more rapid is the apparent movement of light and shadow in the pupil.

*The brightness of the light in the pupil* will depend on the actual brightness of the light area on the retina and on the extent to which this light area appears magnified, being directly proportioned to its actual brightness and inversely to its magnification. The actual brightness of the retinal light area depends on the brightness of the source of illumination and on the accuracy with which the light is focussed on the retina.<sup>1</sup> The brightness of the source of illumination is discussed below; for any given series of tests it may be assumed to be uniform.

If the light from this source could always be perfectly focussed on the retina, the actual illumination of the retinal light area would always be the same, and the apparent illumination would depend entirely on the amplification of the retinal image, as seen in the pupil. However, the light is accurately focussed on the retina only when it comes from the point of reversal; and in practice it will do this only when the surgeon's eye is somewhere near this point. In proportion as the point of reversal is moved from the surgeon's eye (measuring this removal in dioptries,—units of refraction) will the actual illumination of the retina become feeble. When the surgeon's eye is brought exactly to the point of reversal, or within a few inches of it, the immediate source of light cannot be brought directly to it, and in this latter position the amplification of the retina also tends to make the illumination feeble. Hence we have generally the most brilliant lighting of the pupil when the observer is within 1 or 2 D of the point of reversal. Approaching closer than this, the light becomes more feeble, while its movement is more rapid. Departing farther from the point of reversal, the light also becomes more feeble and its movement slower. In this way is deduced the practical rule, that *when the light is feeble and its movement slow, or slight, the observer is considerably removed from the point of reversal; when the light is feeble and its movement swift, he is very close to the point of reversal.*

*The Best Arrangement of the Light.*—The best source of light will be brilliant and occupy but a small area. In practice this will be a small portion from the most brilliant part of some flame, with the other parts

---

<sup>1</sup> See "Retinal Illumination for the Shadow-Test," Jackson, *Ophthalmic Review*, 1890, p. 44.

excluded by an opaque shade. Wax or paraffin furnishes the most brilliant flame; after this come the higher grades of mineral oil, and still inferior to them, gas. But even the latter is a satisfactory source of illumination. The area of flame employed should be between five and ten millimetres in diameter. Larger than this gives more light than is necessary, renders less characteristic the band-like appearance of astigmatism, and makes it more difficult to discriminate between different movements of the light in different parts of the pupil. A smaller area is liable to the objection that too much of it is swallowed up in the sight-hole when it crosses this part of the mirror, causing a sudden fading of the light, or even its complete disappearance. The writer employs simply a metal chimney placed over the ordinary chimney of the Argand gas-burner, with an opening of the proper size placed opposite the brightest part of the flame. To attain the greatest accuracy and delicacy in certain directions, it is important to have the source of light freely movable, as in the universal bracket, so that its distance from the mirror can be speedily and easily adjusted.

*Form of the Light Area in the Pupil in Hyperopia and Myopia.*—In hyperopia or myopia, of whatever degree, the actual shape of the light area on the retina will approach that of the source of light. If, as must be the case for accurate testing, the source of light be small enough to approximate the optical conditions of a single luminous point, where the refraction and, therefore, the magnification of the retina are the same in all meridians, the apparent form of the light area as seen in the pupil will be a circle. When the observer is considerably removed from the point of reversal, so that the retina of the observed eye appears but slightly magnified, the whole of the retinal light area will be visible in the pupil at one time, and its circular shape will be readily recognizable.

When the observer's eye approaches closely to the point of reversal and the visible image of the retina becomes enormously magnified, only a very small part of this circular area being visible at one time, the short segment of its circumference that can be seen in the pupil will have but little curve, and the line separating light from shade will appear comparatively straight. The direction of this straight line, though, will vary according to the part of the retinal light area that is brought in view, and in every direction the rate of movement will be equally rapid.

*Form of the Light Area in Regular Astigmatism.*—In regular astigmatism the *actual* form of the light area on the retina will depend on the position of the retina with reference to the lines into which the eye tends to focus the rays that come from the source of light. If the retina is coincident with one of these lines, the light area has the shape of such a line or narrow band running in a certain direction. If the retina passes through the other focal line, the light area is a similar band running in the direction perpendicular to the first. If the retina be situated at a point intermediate between these two, the light area will be a circle. In other situations the actual form of this area will be an ellipse.

The *apparent* form of the light area, as seen in the pupil, depends, however, more upon the unequal magnification of the retina in different meridians. In regular astigmatism the observer's eye can be at the point of reversal for only one of the principal meridians at one time. In the direction of this meridian the retina is greatly magnified; at right angles to it it is much less magnified. It follows, therefore, that even with an area of light on the retina actually circular in shape, this difference of magnification will make it appear more or less elongated, and this elongation will be most marked when the surgeon's eye is placed at the point of reversal for one principal meridian and the source of light is placed at the point of reversal for the other principal meridian.<sup>1</sup>

The band of light thus made to show in the pupil is the appearance characteristic of astigmatism. If the band be broad, as it is under certain conditions, only one margin of it will appear at a time, and this may look very much like the margin of an enormously enlarged circular area. It will be found, however, on causing the light to move in different directions, that while in non-astigmatic eyes the boundary line may be obtained in any direction, in astigmatism it is always found in the same, or nearly the same, direction, and this is the direction of the principal meridian which has its point of reversal at the observer's eye.

On placing his eye at the point of reversal for the other principal meridian, the surgeon will see a band having its direction perpendicular to that of the first. At distances between these two points of reversal the band-like appearance will be less distinct, or will disappear entirely; but at such points the movement of the light will differ in different meridians: either it will be with the light on the face in the direction of the one principal meridian and against the light on the face in the direction of the other principal meridian, or it will move faster in the one meridian than in the other.

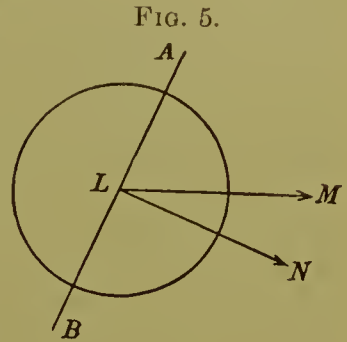
In general, the light and shade in the pupil appear to move in the meridian in which the mirror is turned and the light moves on the face, whether the apparent movement be erect or inverted. An exception to this is seen in the case of a band of light characteristic of regular astigmatism. If the movement of the mirror and the movement of the light on the face be in some direction oblique to that of the band, in whatever oblique direction the mirror be moved, the apparent motion of the band will be at right angles to its length.

This apparent anomaly is due to an optical illusion, which may be illustrated by cutting a small circular hole in the centre of a sheet of paper and placing behind it a card. If this card be uniform, so that all portions have the same appearance on moving it in a direction oblique to its edge, the apparent motion, as watched through the opening, will be perpendicular to the edge. Thus, in Fig. 5, let *AB* represent the edge of the card at the

---

<sup>1</sup> See "The Position of the Source of Light and the Observer in Skiascopy," Jackson, *Archives of Ophthalmology*, vol. xxii. p. 323.

opening. If now the card be moved in the direction of  $LM$ , its edge will appear to move in the direction of  $LN$ . In the case of the shadow-test, the direction of the band of light will be represented by  $AB$ , the direction of its movement by  $LM$ , and the apparent direction of its movement by  $LN$ . This tendency of the apparent movement to be perpendicular to the direction of the band is an aid in recognizing the direction of such a band, and in distinguishing it from an almost straight edge of a nearly corrected hyperopia or myopia. It, however, adds to the difficulty of determining the point of reversal for the meridians in the direction of the band, because, unless the light is made to move exactly in the direction of the band, there will be a very confusing lateral movement of the band itself.



*Appearance of the Light Area in Aberration.*—What has been said about the light in the pupil in non-astigmatic eyes and those the seat of regular astigmatism is theoretically correct; but when the test is applied in practice, such appearances are found, in the large majority of eyes, to be partly or completely masked by the effects of aberration and irregular astigmatism.

The *aberration* of the eye commonly resembles that of the ordinary spherical lens, being such that the refraction is least at the centre and greatest at the margin of the pupil. This I have called *positive aberration*.<sup>1</sup> The centre of the pupil is more hyperopic and less myopic than the margin. This difference of refraction causes a difference in the point of reversal. The point of reversal for the margin of the pupil is usually much closer to the eye than the point of reversal for the centre of the pupil. Hence, when the observer's eye is situated between the two, he sees the light at the centre of the pupil moving with the light on the face (plane mirror), while the light in the margin of the pupil is moving against the light on the face, and between the two is a neutral zone, the point of reversal for which is situated at about the observer's eye, in which the light is extremely feeble and the direction of its movement imperceptible. The typical appearance, then, presented by a case of ordinary *positive aberration* is that of an area of light in the centre of the pupil giving the erect movement, and a ring of light near the pupillary margin with an inverted movement.

In a certain number of cases the relations of the centre and margin of the pupil are reversed; the centre is more myopic and less hyperopic, the margin less myopic and more hyperopic, constituting *negative aberration*. In these cases there exist the same neutral zone and the same central area and peripheral ring of light, but this ring is usually much less clearly marked than in positive aberration.

<sup>1</sup> Symmetrical Aberration of the Eye. Transactions of the Amer. Ophthalmol. Soc., 1888, vol. v. p. 141.

In any case of aberration, if the surgeon places his eye near the point of reversal for the margin of the pupil, it will be comparatively far removed from the point of reversal for the centre of the pupil. The movement of the light at the margin will then be rapid; the movement of the light area at the centre will be slow. Although the movements may be all in the same direction, this will cause the light in the margin to appear to run around the light at the centre, giving the effect of a light area fixed at the centre and turning about this point as on a pivot. When the light is thrown from one side of the mirror, the light in the pupil will appear triangular in shape, with its base on one side of the pupil. When the light area on the face is moved across to the other side of the eye, the triangular area of light in the pupil will be found to have wheeled around, so that its base is towards the other margin. It is this wheeling, somewhat triangular, area of light in the pupil that has been regarded as characteristic of conical cornea. Its recognition was made the first application of the shadow-test, but it does not necessarily indicate conical cornea. Conical cornea causes very high negative aberration, but the more common positive aberration is also capable of producing essentially the same appearance.

*Appearance in Irregular Astigmatism.*—In irregular astigmatism the refraction differs entirely from point to point of the pupil, and thus gives rise to an infinite variety of combinations of light and shadow, which are intelligible only when the observer keeps clearly in mind the general optical principles of the test. Thus, wherever erect movement is perceived, the point of reversal is back of the observer; wherever inverted motion is noticed, it is in front of the observer; and in limited areas of the pupil may be recognized characteristic bands of regular astigmatism, while other portions may be free from it.

One group of cases that we can scarcely class anywhere but under this general title of irregular astigmatism presents a characteristic movement of light and shadow which deserves special mention. This is what I have been in the habit of calling the *scissors movement*. There appear two more or less distinct areas of light occupying different portions of the pupil at the same time. When the light on the face is made to move in one direction, these light areas in the pupil come together; when the light on the face is moved in the opposite direction, they separate very much as do the blades of a pair of scissors. Such areas have usually an approximately straight boundary, and often resemble somewhat the band-like appearance of regular astigmatism, and in cases of this kind regular astigmatism is very frequently present. The appearance depends on the fact that one side of the pupil has a higher hyperopia or a lower myopia than the other side, so that when the light is moved in a direction perpendicular to the line separating the two portions, an erect movement is obtained in one part of the pupil and an inverted movement in the other.

The position of the line separating the erect from the inverted movement will vary with the distance of the surgeon from the patient, or with



the strength of the lens placed before the eye. As the convex lens is made stronger, or the concave lens weaker, or as the surgeon withdraws farther from the patient's eye, the area of inverted movement will enlarge and the area of erect movement will diminish. If, on the other hand, the strength of the concave lens is increased, or the strength of the convex lens is diminished, or the surgeon brings his own eye nearer to that of the patient, the area of direct movement will be enlarged and the area of inverted movement diminished.

Always between the two is a zone of comparatively feeble illumination, for which the point of reversal is just at the observer's eye, and in estimating the strength of the correcting lens this neutral zone must be made to include the centre of the pupil, the portion that will be available for purposes of vision when the pupil is contracted, as in a strong light or with convergence.

The scissors-like movement of the light area in the pupil may be imitated by applying the shadow test to the artificial eye, with the lens representing the dioptric surfaces tilted, so that the rays shall pass through it obliquely. It may also be brought out in most eyes by applying the shadow-test, not in the direction of the visual axis, but at a considerable angle from the visual axis. It is probable that in most cases in which it is noticed in the direction of the visual axis it is due to an oblique position of the crystalline lens.

#### PRACTICAL APPLICATION OF THE TEST.

**The Plane Mirror.**—When we come to fix accurately the point of reversal, it is essential that the retinal light area should be as small and sharply defined as possible. On this account it is necessary that the immediate source of light should be as near to the point of reversal as possible. With the plane mirror, this source being an image of the flame employed, as far back of the mirror as the flame is in front of it, to bring it to the point of reversal at the same time with the surgeon's eye it is essential to have the original source of light as close to the mirror as possible. Therefore the patient is to be placed in a thoroughly darkened room, to give contrast between the general shadow, and the light on the face and in the pupil. A movable flame covered with a metal chimney, in which an opening five to eight millimetres in diameter is cut opposite the brightest part of the flame, is brought as close to the surgeon's eye and the mirror as is convenient, and the light reflected by the mirror on to the patient's face is made to move in different directions by the changes of inclination of the mirror.

**Hyperopia.**—In hyperopia the movement of the light in the pupil is found to be with that of the light on the face. If the hyperopia be of a high degree, the point of reversal being many dioptries from the observer's eye and the light giving a comparatively large circle of diffusion on the patient's retina, the movement of light in the pupil is slow and the illumination comparatively faint. Under these circumstances it is often necessary to use

quite a broad mirror (twenty-five to forty millimetres in diameter) and to rotate it rapidly in order to make sure in which direction the light moves.

By the faintness of the illumination and the slowness of its movement the surgeon must estimate about the strength of lens that will be necessary to give him the point of reversal, and such a lens he places before the eye. Then repeating the observation, if the light still has a direct but rapid movement the surgeon will draw back from the patient, keeping the source of light as close to his mirror as practicable. Thus the distance from the patient's eye is to be increased until an inverted movement of the light is noticed, or until the apparent size of the pupil has so diminished that it becomes difficult to be sure in which direction the light is moving. Should he find the movement in the pupil already inverted, the observer will bring his eye, and necessarily the source of light also, closer to the patient until erect movement is obtained.

Then the observation should be verified by a number of repetitions, finding both the greatest distance at which erect movement is seen, and the least distance at which the inverted movement is visible. Between these two lies the point of reversal. One not thoroughly familiar with the test should be reminded that the movement differs in different portions of the pupil, and that the movement it is of practical importance to study is that in the visual zone at the centre of the pupil,<sup>1</sup> while the movement in the periphery of the dilated pupil is to be disregarded.

For the final accurate determination such a lens should be placed before the eye as will bring the point of reversal to the greatest distance from which the movement within the visual zone is readily visible. For most eyes this is one metre or less. The most accurate determination can be made when the surgeon's eye is slightly closer to the patient than the point of reversal, so that in practice the greatest distance at which the erect movement is visible may be taken as the point of reversal sought.

For example, suppose the original observation give a faintness of reflex in the pupil and a slowness of erect movement judged to indicate 5 D of hyperopia, but the convex 6 D lens being placed before the eye the movement is still found to be with that of the light on the face, even when the surgeon draws back six or eight feet from the patient, at which distance the direction of movement becomes uncertain. The 6 D lens is then to be replaced by a 7 D lens, and with it the movement of light in the pupil is found to be reversed. The surgeon then, approaching the patient, finds on reaching 0.50 metre that he has a distinct movement with that of the light on the face. He is, therefore, within the point of reversal. He draws back again, and finds that at thirty inches all movement is inverted, while at twenty-four inches there appears a slight direct movement in the centre of the pupil. This indicates that with the 7 D lens the point of reversal is

---

<sup>1</sup> "The Visual Zone of the Dioptric Media and its Study by Skiascopy," Jackson, *Journal of the American Medical Association*, Sept. 1, 1894.

about two-thirds of a metre from the eye, corresponding to 1.50 D of myopia. The hyperopia of the eye, therefore, is 7 minus 1.50 equal 5.50 D. To verify this, the 6.50 D lens may be placed before the eye, and the observation made that with it the erect movement is distinguishable up to thirty-eight or forty inches.

*Myopia.*—In myopia, the original observation without a glass shows inverted movement in the pupil. The surgeon then brings his eye closer and closer to that of the patient until erect movement is seen; then measuring from the patient's eye to the greatest distance at which this erect movement is visible gives the focal distance of the lens required for the correction of the myopia. This first estimate will, of course, be only approximate, but will serve to indicate very closely the proper lens to use for the more accurate measurement, which lens should be about 1 D less than the amount of myopia indicated. Placing this lens before the eye, the point of reversal is sought with it as in the case of hyperopia, fixed in the same way, and its distance from the eye measured; and the lens having this focal distance, added to the lens already before the eye, gives the full correction for the myopia present. If the amount of myopia present be about 1 D, the accurate determination will be made without the use of any lens whatever.

For example, suppose, in a case of high myopia, the erect movement is not visible until the surgeon is within four inches of the patient's eye. This would correspond to a myopia of about 10 D; a 9 D concave lens is then to be placed before the eye and the test repeated. If now it is found that the erect movement is visible at from thirty-eight to forty inches and the inverted movement distinctly seen at forty-five or fifty inches, corresponding to 1 D of myopia still remaining uncorrected, the total amount of myopia present will be 9 plus 1 equal 10 D.

In the case of very low myopia the first trial will show erect movement in the pupil, but this movement will be very rapid. The surgeon should then withdraw farther from the patient's eye until erect movement ceases and only inverted movement appears in the pupil, or until such a distance is reached that the direction of movement is no longer easy to determine. In the latter case a weak convex lens should be placed before the eye and the determination made as for a case of hyperopia. When this has been done, however, it will be found that the amount of myopia with the lens is greater than the strength of the lens, and the strength of the lens, deducted from the myopia with it, will leave the amount of myopia originally present.

In a case of low myopia, suppose it has been impossible to get a distinct reversal of movement without a lens, and a convex 1 D lens gives a point of reversal at twenty-six inches, this would correspond to 1.50 D of myopia, and from this deducting 1 D of convex lens employed, we find the original myopia to be 0.50 D.

*Emmetropia.*—Without a lens before the eye, the movement will be found

with that of the light on the face, just as in low hyperopia. The placing of a convex lens and the subsequent testing are to proceed in precisely the same way as for hyperopia. But in the end it will be found that the point of reversal is just at the focal distance of the lens used, showing that the rays emerged from the eye and reached the lens parallel.

In any case of myopia or hyperopia, before accepting the results of the shadow-test, the movement of the light should be tried in various meridians, and should be found the same in all. It should also be carefully noted whether the area at the centre of the pupil, for which the refraction is determined, be large or small, and whether from it the refraction increases or diminishes rapidly towards the margin of the pupil, since these points may have important practical bearings in the decision as to what glasses should be worn, and how constantly. It is also well to test both eyes together by placing before them lenses which will bring their points of reversal to the same distance, and then to compare the movement of the light in the two pupils at this distance, and also nearer and farther away.

*Regular Astigmatism.*—In regular astigmatism the examination will begin as for simple myopia or hyperopia, but when a point of reversal is found it will be discovered that it is a point of reversal for only a single meridian, and that for any other meridian the point of reversal is situated elsewhere. Or it may be noticed before this that the light moves more rapidly in one meridian than in another, and from this the presence of astigmatism may be inferred.

When the discovery is made that astigmatism is present, the surgeon should try first to find the point of reversal nearest to the patient's eye,—the one for the meridian of greatest myopia or least hyperopia. Having found this point with a lens that brings it rather close to the eye (one-half metre or less), the source of light, which has hitherto closely followed the changes of distance of the mirror from the patient, is now moved away from the mirror as far as may be found necessary. As it is moved away, the appearance of the light is watched in the pupil, and when the source of light has reached the point of reversal for the more hyperopic or less myopic meridian, the most distinct band-like appearance of the light in the pupil will be obtained. Under these circumstances, with the surgeon's eye at the near point of reversal and the source of light at the more distant point of reversal, the direction of one principal meridian, as shown by the direction of the band of light, is to be accurately determined. The other principal meridian is, of course, just perpendicular to this. Having determined the direction of the principal meridians, the light is again to be brought back as close to the mirror as possible and the measurement of the amount of myopia in each principal meridian made, as in a case of simple myopia or hyperopia. The difference of refraction between the two principal meridians gives the amount of astigmatism.

After the astigmatism has been thus determined, it is always wise to place before the eye the cylindrical lens correcting it, and again to study the

movements of light and shadow from near the point of reversal. If the determination already made be not perfectly accurate, the pupil will still present the appearance of low astigmatism. There may be no distinct band, but at one distance the light will have no perceptible movement in one meridian, while at right angles to this there will be a perceptible movement, either with or against the light on the face. If these meridians correspond in direction to those originally determined, it is only needful to increase or diminish the strength of the cylinder. If, however, the meridians of the remaining low astigmatism appear to differ from those originally fixed upon, then the direction of the axis of the cylinder needs to be slightly altered to give a perfect correction.

*Irregular Astigmatism.*—In all eyes, as the point of reversal is approached, there becomes apparent a certain amount of irregular astigmatism. Up to a certain point the movements of light and shadow follow the rules laid down; but when the observer approaches the point of reversal within this limit, new distributions and movements of light and shadow appear, peculiar to the individual case. As they become pronounced, the determination of the exact point of reversal sought becomes uncertain and difficult: so that in general the accuracy of the result attained by skiascopy will be limited by the amount of irregular astigmatism present in the visual zone of the cornea. In every case these irregular movements should receive careful attention, since among them may be found some one, usually at the centre of the pupil, of especial significance; and even where such a movement cannot be distinguished, the amount of irregular astigmatism revealed will be an indication of the probable visual acuteness to be obtained by subjective tests.

*The Near-Point of Accommodation.*—The point of reversal can be as well determined when it is brought close to the eye by the exertion of the accommodation as when it is so situated from the presence of myopia. To determine its position when the accommodation is exerted to its maximum, it is only necessary to have the patient fix a small object held close to his eye in the direction of the surgeon's eye. If the patient's eyes converge to this point, he will necessarily exert his full power of accommodation, and the position of the point of reversal under these circumstances is to be ascertained as in a case of simple myopia.

**The Concave Mirror.**—The *immediate* source of light with the concave mirror is the small image of the flame formed at the focus of the mirror conjugate to the position of the *original* source of light.

To bring this immediate source of light as close to the observer's eye as possible, so that both together may approach the point of reversal, the original source of light must be removed a considerable distance from the mirror. The light is to be back of the patient's head, usually the farther back the better. With the light in this position, the shading of it by a metal chimney with a small aperture is of less importance than with the plane mirror, yet it adds something to the accuracy of the results attainable.

It is also of no importance to have the position of the light movable, except for the exact determination of the principal meridians of astigmatism. On the other hand, the observer must place himself at a fixed distance from the eye he is testing. This distance should be the greatest from which he can watch clearly the movement of light and shade in the pupil, because the distance between the mirror and its focus remaining practically the same, as measured in inches or in centimetres, the difference of dioptries corresponding to this distance will diminish as the total distance from the patient's eye increases.

Variations in the focal distance of the mirror employed, or in the position of the original source of light, will permit variations of the distance of the surgeon from the patient; but in general, with a mirror of twenty to twenty-five centimetres' focal distance (eight to ten inches), and the light some little distance back of the patient's head, the surgeon should be about one metre from the eye he is testing. From this position, then, he watches the play of light and shade in the pupil when the mirror is rotated.

*Hyperopia.*—The movement of light on the retina being really in the direction opposite to that of the movement of light on the face, when the retina is seen in the erect image, the light in the pupil appears to move against the light on the face—against the mirror. The rapidity of this movement becomes the chief indication of the degree of hyperopia. The movement being slow, the hyperopia is probably high. If it be fast, the hyperopia is probably low.

The lens which is expected to correct the hyperopia and cause, in addition, 1 D of myopia, is placed before the observed eye. Through this lens the movement of light in the pupil is again observed. If it be still against the light on the face, a stronger lens must be employed, and the rapidity of its movement is a gauge of the amount of additional strength required. When, however, the light in the pupil is found to move with the light on the face, it is known that a lens has been reached which brings the point of reversal closer to the patient than the surgeon's position, which, therefore, causes more than 1 D of myopia, and a weaker lens is to be tried. In this way, trying alternately stronger and weaker lenses, is ascertained the strength required to bring the point of reversal to one metre. The nearest approach to this will generally be the weakest convex which causes movement in the pupil with the light on the face, because with this lens the point of reversal, lying somewhere in front of the surgeon's eye, is in close proximity to the position of the immediate source of light at the focus of the mirror, and the conditions are, therefore, favorable for the most accurate test. The lens which does this corrects the hyperopia and causes 1 D of myopia, and by subtracting 1 D from its strength the correction of the hyperopia is found.

For example, suppose on the first inspection the light in the pupil is seen to move slowly against the light on the face. A 6 D convex lens placed before the eye still allows it to move against the light on the face, but very swiftly. The 6.50 D lens, however, causes the light in the pupil to

move with the light on the face, also very swiftly. The presumption is that the lens causing 1 D of myopia lies between the 6 D and the 6.50 D; but the latter, conforming to the conditions of the more delicate test, may be assumed as the nearer right, and 1 subtracted from the 6.50 D leaves 5.50 D as the amount of hyperopia present. The lens strength obtained in this way will always be a full correction.

*Myopia.*—In myopia of over 1 D, the light, on first testing without any lens, will be found to move with the light on the face, and according to the slowness of its movement will be the strength of the concave lens required before the patient's eye to bring the point of reversal to the observer's position. So long as the light moves with the mirror,—with the light on the face,—the lens is too weak; so soon as it begins to move against the light on the face, the lens is too strong. By repeated trials, the two lenses are found between which the reversal of movement occurs, and the strongest concave allowing of erect movement is fixed upon as the one leaving a single dioptré of myopia uncorrected. To find the correction of the total myopia, then, 1 D is added to the strength of the strongest concave that allows the movement of light in the pupil with the movement of light on the face.

Where the myopia is less than 1 D, the movement in the pupil is found from the first to be against that of the light on the face, and to produce reversal a convex lens must be used. It is found, however, that the weakest convex that produces movement with the light on the face is weaker than 1 D; that is, a convex lens of less than 1 D causes 1 D of myopia. Hence its strength subtracted from 1 D will give the amount of myopia present in the eye to start with, or the concave lens required for its correction.

*Emmetropia.*—In emmetropia also the light is first seen to move against the light on the face, but is brought to move with it by a 1 D convex lens. Here, the amount of myopia produced being just equal to the strength of the lens, the original refraction must have been emmetropic.

*Regular Astigmatism.*—The presence of this condition will be suspected or recognized so soon as it is found that with a given lens the movement is faster in some one meridian than in the meridian perpendicular to it, or that the movement in one meridian is with the light on the face and in the meridian perpendicular to it against the light on the face, or when it is found that for one meridian the point of reversal has been brought to the surgeon's eye, while there still exists a distinct movement, either erect or inverted, in the meridian at right angles to it. So soon as this is recognized, the surgeon's attention is to be directed to determining the lens which brings his eye to the point of reversal for the meridian of greatest hyperopia or least myopia, this lens giving no movement in one principal meridian, and in the other a distinct movement with the light on the face.

With this lens in front of the patient's eye, and keeping his own position one metre from it, the surgeon is to have the original source of light brought closer and closer to the mirror until the immediate source of light, which correspondingly retreats from the mirror, reaches the neighborhood of the

point of reversal for the other principal meridian. In this position the band-like appearance of light in the pupil comes out most distinctly, and the direction of one principal meridian (commonly the horizontal) is accurately determined, the direction of the other principal meridian being perpendicular to this.

The original source of light is then removed again to its maximum distance, to bring the immediate source of light as close as possible to the mirror, and the lens ascertained that brings the point of reversal to the distance of one metre,—first for one principal meridian and then for the other. The difference between the two gives the strength of the cylindrical lens required to correct the astigmatism.

To complete the test, this correcting cylinder should be placed before the eye, with the spherical which should bring the point of reversal to a distance of one metre, and the play of light and shade in the pupil should again be carefully studied, to discover any evidence of astigmatism remaining uncorrected. By the amount and direction of this uncorrected astigmatism the cylindrical lens is to be modified, as explained for the plane mirror.

*Aberration and Irregular Astigmatism.*—The effects of these conditions upon the appearance and movements of the light in the pupil are much the same as with the plane mirror. We have to encounter, usually (positive aberration), the circle of light in the margin of the pupil now moving with the light on the face, while the central fainter area of light moves against the light on the face. The reverse relation of movement is seen in negative aberration. The wheeling triangle of light in conical cornea, the scissors-like movement in obliquity of the crystalline lens, and the broken patches and variety of movement, with and against the light on the face, are of similar significance.

What is said as to the test with the plane mirror applies equally here. These appearances should always be looked for and carefully studied. So considered, they will frequently throw valuable light upon practical aspects of the case.

**Relative Advantages of the Plane and the Concave Mirror.**—Each of these varieties of skiascopy has certain advantages over the other. The *concave* mirror, at first more widely used, gives the better results, when the original source of light is large and irregular in outline but can by removal to a considerable distance from the mirror be made to give a sufficiently small immediate source of light. With the concave mirror, the changes being made by changes of lenses, the appearance shown by one lens gives place to a distinctly different appearance brought out by another lens; and the definite selection of the lens sought is, perhaps, easier than with the plane mirror, where the appearances present at different distances fade gradually one into the other.

In regular astigmatism, the concave mirror, with its immediate source of light in front of it, enables one to fix most accurately the meridian of greatest hyperopia or least myopia.



In aberration, the immediate source of light being in front of the mirror, and the rays from it, therefore, intercepted before they reach the focus, the margin of the light area becomes in some cases slightly sharper by reason of the condensation ring of aberration. This latter advantage is, however, rarely perceptible in practice.

The *plane* mirror, on the other hand, permits the determination of the point of reversal with fewer changes of lenses; and since to secure certainty and accuracy requires repeated trials both from within and beyond the point of reversal, it is a very great advantage to be able to make these trials without repeated changes of the lens in front of the eye. The plane mirror enables the surgeon to do this simply by slightly varying his distance from the patient. Then the plane mirror, by making the test more flexible, makes it also more valuable in the extent and exactness of its results. The exactness attainable with the concave mirror is limited by the interval between the glasses used; with the plane mirror it is not.

With the plane mirror the meridian of least hyperopia or greatest myopia can be fixed with the greater accuracy, and in negative aberration the light area of the retina shows a more distinct border. In general, the light area of the retina is brighter and more sharply defined, because by bringing the original source of light close to the mirror the immediate source can always be kept near the observer's eye and nearer to the point of reversal than it is possible to bring the focus of the concave mirror. With the plane mirror the principles of the test are more easily mastered, and on this account skiascopy should first be studied with it.

One will have at his command all the resources of the shadow-test only if he be thoroughly familiar with its use in both forms.

#### USE TO BE MADE OF THE TEST.

Skiascopy is applicable to the measurement of refraction in all cases. It therefore has a certain usefulness where other methods cannot be employed, as for the lower animals, for children whose movements cannot be controlled, for cases of nystagmus, and in some cases of hazy media where the other chief objective method of determining refraction (the ophthalmoscope) cannot be satisfactorily employed.

The writer has found it more valuable than all other methods together where an objective method must be chiefly relied on, as in measuring the refraction of applicants for benefits or pensions; but its most general application is as an objective method to furnish the foundation for the subjective tests. These latter are rendered easier of application and more certain in their results when they can begin by the bringing before the eye of a close approximation to the accurate correction, and this the shadow-test can readily be made to yield.

The writer's practice is, after the ophthalmoscopic examination, which gives approximately the hyperopia or myopia, and the use of the ophthalmometer, which indicates the probable astigmatism, to employ the shadow-

test, which checks or corrects the results obtained by the other objective methods and gives an almost perfectly accurate idea of the ametropia present, that has only to be slightly revised or confirmed by the subjective test with lenses. Used in this way, it not only gives greater certainty to the result by reason of arriving at it by an independent method, but it always saves much more time than is required to employ it, and it gives information as to the existence of residual accommodation, aberration, or irregular astigmatism which can be obtained in no other way, and which in a large proportion of patients is of decided practical value.

#### APPARATUS.

The mirror must be large where the test is to be relied on alone; but is more convenient to be small, fifteen to twenty millimetres in diameter, if the test is used to confirm and revise the results of other tests. The sight-hole should be about two and a half millimetres in diameter, and absolutely free from reflections at its margin. The best I have used have merely had the silvering removed from the back, leaving the glass unperforated.

If the plane mirror is employed, a movable bracket is required to support the light; and a metal chimney to enclose it, with an aperture of five to eight millimetres in diameter opposite the brightest part of the flame. These, with the trial set of lenses, are all that are necessary. It is, however, convenient to have a metre stick, upon which is laid off a scale of dioptric focal lengths, for the measurement of the distance from the point of reversal to the patient's eye. With the concave mirror, the swinging bracket to support the light and the metal shade are of less importance; but it may be a convenience to have, instead of the lenses from the trial case, a series of spherical lenses arranged in a disk or slide, as suggested by Hill Griffith, Burnett, Würdemann, and others. I have employed such a disk arranged with lenses running from 7 D convex to 7 D concave, with intervals of 0.50 D, and rotated by a rod fastened to its face by a universal joint. Where the test is to be applied with the concave mirror to large numbers of patients, some such apparatus is worth having.

#### HISTORY AND NAME OF THE TEST.

The method of investigation and diagnosis we have been considering was differentiated from the general ophthalmoscopic examination by Bowman, who called attention to it for the detection of irregular astigmatism and conical cornea, in a paper upon conical cornea in the *Royal London Ophthalmic Hospital Reports*, vol. ii. page 157. Later he recognized the somewhat "linear shadow in some meridians rather than in others," significant of regular astigmatism, as already mentioned.

As a test for conical cornea and irregular astigmatism, its application continued and became general, but for several years received no further development. In 1872, John Couper, of London, read before the Fourth International Ophthalmological Congress a paper on "The Ophthalmoscope

as an Optometre in Astigmatism," in which he proposed as a test the recognition of the reversal of the image of the retinal vessels and its distortions at various distances. His method does not seem to have been adopted by others. Two or three years later Cuignet, of Lille, described the test with the plane mirror, announcing that it was applicable to the recognition and measurement of all forms of ametropia; but, apparently supposing the different appearances elicited by it to depend entirely on the curvature of the cornea, he termed the test *kératoscopie*. This was the first distinctive name given to it.

Mengin, a pupil of Cuignet, introduced the practice of the method in Paris, where it was taken up by Parent, who demonstrated its optical basis and used the concave mirror; and because the play of light and shade in the pupil was really due to the movement of an area of light on the pigment-layer of the retina, he called it *rétinoscopie*. After this, Lytton Forbes (1880) and Charnley (1882) wrote upon it in the *Royal London Ophthalmic Hospital Reports*. The former described rather minutely the forms of light and shade observed in the pupil, but without full explanation of their optical basis. The latter somewhat extended Parent's optical demonstration regarding it. Chibret, in 1882, urged the advantages of the plane mirror for the detection of myopia sufficient to exclude recruits from military service. He proposed the name of *fantoscopie rétinienne*. Story, in the *Ophthalmic Review*, 1883, described the test with the plane mirror, which he used in the same manner as the concave, but at a greater distance. A year later, in the same journal, Priestley Smith, in suggesting a simple mirror for it, spoke of the method as the *shadow-test*. The writer's description of the test with the plane mirror, varying the distance of the surgeon from the patient, for the measurement of all errors of refraction, was published in 1885.<sup>1</sup>

Landolt proposed calling the test *pupilloscopie*, because it was in the pupil that the phenomena were to be studied, and later, for etymological reasons, suggested the equivalent *koroscopie*. The term *skiascopy* was proposed by the Greek scholar M. Egger, at the request of Chibret. Being a simple word constitutes its superiority to the popular term shadow-test; and being inapplicable to any other kind of examination, it cannot permit the confusion which might arise from the use of *kératoscopie*, *rétinoscopie*, or *koroscopie*, which are all applicable to examinations of the cornea, retina, or pupil for totally different purposes.

During the past ten years much has been written about the test, but no important contribution made to its development, except, perhaps, the elucidation of the effect of various relations of the light and the mirror to the observed eye. The elaboration of these, and a more extended consideration of the subject than is here practicable, are to be found in the writer's monograph published in 1895.

---

<sup>1</sup> The American Journal of the Medical Sciences, April, 1885.



# OPHTHALMOMETRY AND ITS CLINICAL APPLICATIONS.

BY ADOLPHE JAVAL, JR.,

Paris, France.

TRANSLATED.

---

## I.—THE PURPOSE AND USES OF THE OPHTHALMOMETER.

OPHTHALMOMETRY, as its name indicates, has for its object the measurement of the different parts of the eye.

Under ophthalmometry we may consider two entirely distinct problems, the one looking to the general investigation of the dimensions of the average normal or schematic eye, the other to the measurement of the actual dimensions of individual eyes.

To construct a schematic eye we may have recourse to anatomy,—*i.e.*, to measurements made upon the cadaver; but, by reason of the changes which take place after death, the investigation should be conducted as far as possible on the living subject.

In his immortal memoir,<sup>1</sup> which Tscherning has lately reprinted with annotations,<sup>2</sup> Thomas Young describes, among other things, how he measured his own eye. These measurements were made with such precision that even at this day we may accept them as exact.

Young first measured the diameter of the cornea with dividers. He then measured the height of the cornea by looking “with the right eye at the image of the left, in a small speculum held close to the nose, while the left eye was so averted that the margin of the cornea appeared as a straight line;” he “compared the projection of the cornea with the image of a cancelled scale held in a proper direction behind the left eye and close to the left temple.” Having thus found the diameter and the versed sine of the cornea, he calculated the radius of curvature, assuming the cornea to be a segment of a sphere. He determined also the eccentricity of his own cornea with reference to the visual axis. By investigating the refraction of his eye under water, he discovered that the cornea took no part in the act of accommodation. To measure the length of the eyeball he made use of blunt dividers, applying one of the tips to the vertex of the cornea and

---

<sup>1</sup> Philosophical Transactions, 1801.

<sup>2</sup> Œuvres Ophthalmologiques de Th. Young, par M. Tscherning, 1894.

the other to the posterior pole of his eye. In executing this remarkable experiment he turned his eye—which is stated to have been very prominent—strongly inward, and he made use of the phosphenes to assure himself that the posterior tip of the dividers was placed exactly upon the posterior pole.

But for the fact that Young's methods were such as to demand unusual experimental skill on the part of the observer, the repetition of his measurements by others might easily have led to the construction of a schematic eye. The complete solution of this problem was, however, reached by other and more convenient methods devised by Helmholtz and applied by him and by his disciples.

In the practice of ophthalmology it is the second of our two problems that mainly interests us,—namely, the measurement of individual eyes; for it is evident that if we could make such objective examinations exhaustively and rapidly there would no longer be any need of resorting to the subjective determination of the refraction.

In the present stage of development of ophthalmometry, one dimension of capital importance eludes measurement,—namely, the distance of the cornea from the retina. Failing so important a measurement, there is no very urgent reason for investigating either the exact position or the dimensions of the crystalline lens. The inquiry may, therefore, be confined to the measurement of the curvature of the anterior surface of the cornea in its different meridians. Such measurements are of interest in cases of variation in the tension of the eye, but they are of especial importance in the diagnosis of astigmatism, as enabling us both to form an approximate estimate of its grade and to determine the direction of the principal meridians.

It is reasonable to expect that in the near future the applications of practical ophthalmometry may be so far extended as to include the measurement of the curvature of the posterior surface of the cornea and the estimation of the obliquity of the crystalline lens, besides affording information on other points for which we have now to rely on subjective tests.

For a review of actual progress in the direction of the solution of these problems we refer the reader to the “*Mémoires d'Ophthalmométrie*,”<sup>1</sup> in which the principal memoirs bearing more or less directly upon this part of ophthalmology have been brought together in their original languages.

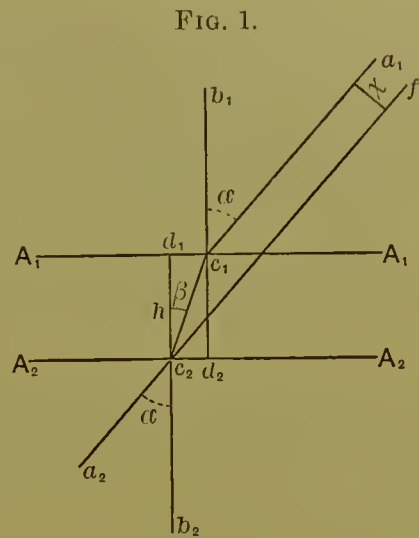
## II.—THE OPHTHALMOMETER OF HELMHOLTZ.

The genius of Helmholtz inaugurated a new era in ophthalmometry. In 1854, in the *Archiv für Ophthalmologie*, appeared his paper “*Über die Accommodation des Auges*,” in which he gave a detailed description of the ophthalmometer, together with the results of investigations made with the aid of that instrument.

The ophthalmometer of Helmholtz, which is essentially a modification of one of the forms of the heliometer, consists of a telescope having in front

<sup>1</sup> E. Javal, *Mémoires d'Ophthalmométrie*, Paris, 1890.

of its objective two plates of glass, with parallel plane surfaces, placed side by side, so that each plate corresponds to one-half of the objective. So long as the two plates lie in the same plane, only a single image is seen through the telescope; but when the plates are rotated in opposite directions, the rays emanating from the object are separated into two bundles, and two images are seen, the distance which separates these two images increasing with the angle through which the plates are turned. When the rotation of the plates is such that the two images of a linear object are seen exactly in contact, end for end, the distance by which the two images are separated is exactly equal to the length of each image; the amount of displacement of the two images may then be calculated from the angle made by the plates with the axis of the telescope.



This method, which was originally employed in astronomy in the measurement of small angular distances, as in the case of double stars, has the special advantage that it does not require complete immobility of the object to be measured.

Let  $A_1A_1$ ,  $A_2A_2$  (Fig. 1) represent one of the two refracting plates; let  $a_1c_1$  be an obliquely incident ray; let  $c_1c_2$  be the same (refracted) ray in its course within the plate; let  $c_2a_2$  be the same (twice refracted) ray emergent at  $c_2$  and parallel to the incident ray  $a_1c_1$ . Draw  $b_1c_1d_2$  normal to the two parallel surfaces at the point of incidence, and  $b_2c_2d_1$  normal to the same two surfaces at the point of emergence. We will designate the angle of incidence  $b_1c_1a_1$ , which is equal to the angle of emergence  $b_2c_2a_2$ , by  $\alpha$ ; the angle of refraction  $d_2c_1c_2$ , which is equal to the angle  $d_1c_2c_1$ , by  $\beta$ ; and the thickness of the plate  $d_1c_2$  by  $h$ . Extending the emergent ray  $c_2a_2$  backwards to  $f$ , the image of the point  $a_1$  will, to an observer stationed anywhere in the line  $a_2c_2$ , appear to lie in the direction of  $f$ , and the line  $x$ , drawn perpendicularly from the line  $a_1c_1$  to the line  $c_2f$ , will represent the amount of the lateral displacement of the point  $a_1$ .

Now,

$$\frac{h}{c_2c_1} = \cos \beta,$$

$$c_2c_1 = \frac{h}{\cos \beta}.$$

Again,

$$\frac{x}{c_2c_1} = \sin c_1c_2f = \sin (\alpha - \beta),$$

$$x = c_2c_1 \cdot \sin (\alpha - \beta)$$

$$= \frac{h}{\cos \beta} \cdot \sin (\alpha - \beta) = h \cdot \frac{\sin (\alpha - \beta)}{\cos \beta}.$$

The angle  $\alpha$  is found from the reading of the instrument; knowing

also  $n$ , the index of refraction from air into glass, we have, by the law of refraction,

$$\sin \alpha = n \cdot \sin \beta.$$

From this equation we may deduce the values of  $\cos \beta$  and of  $\sin (\alpha - \beta)$ , and, knowing also  $h$ , the thickness of the glass plate, we have all the data required for calculating  $x$ .

Inasmuch as, by the construction of the instrument, we have two plates, which are rotated symmetrically in opposite directions, the separation of any two corresponding points in the double image is equal to  $2x$ . Designating  $2x$  by  $E$ , we have

$$E = 2h \cdot \frac{\sin (\alpha - \beta)}{\cos \beta}.$$

In default of other determinations, the values  $h$  and  $n$  may be calculated from measurements made with the instrument itself; but in practice it is quite unnecessary to know them, or, indeed, to make use of any calculation in order to find the value of  $E$ . By directing the telescope upon a finely graduated scale, the successive values of  $\alpha$  corresponding to successive displacements of tenths of a millimetre may be observed and tabulated or plotted for subsequent reference. It is then only necessary to observe the angle  $\alpha$  through which the plates have been rotated in order to bring the double images into the position of contact, and to take the corresponding value of  $E$ , which represents the length of the image, from the table.

The separation of the double images corresponding to a rotation of  $\alpha^\circ$  corresponds also to a rotation of  $-\alpha^\circ$ , of  $180^\circ - \alpha^\circ$ , and of  $180^\circ + \alpha^\circ$ . To eliminate instrumental errors, it is advisable to repeat each measurement for these four positions and to adopt the mean of the four readings.

To investigate the curvature of the cornea, Helmholtz observed on the cornea, as in a convex mirror, the double image of a luminous object consisting of a group of three small flames disposed in a row. The catoptric focus and the radius of curvature of the cornea are calculated from the known length and distance of the luminous object and the length of the reflected image, as found from the observed value of the angle  $\alpha$ .

It will be remarked that the distance of the observed eye from the micrometric plates does not enter into the formula for calculating the length of the image formed by reflection on the cornea; it is, therefore, unnecessary to know this distance, and it is convenient to take it pretty large. The distance of the luminous object from the observed eye should also be large in comparison with the length of the object, so that the length of the image may be small in comparison with the radius of curvature of the cornea; any error that may arise from inevitable slight variations in distance, due to involuntary to-and-fro movements of the patient's head, will then be so small as to be safely negligible, and the corneal curvature may be calculated with sufficient accuracy from the proportion

$$\frac{\text{Half radius of curvature}}{\text{length of image}} = \frac{\text{distance of object}}{\text{length of object}}.$$

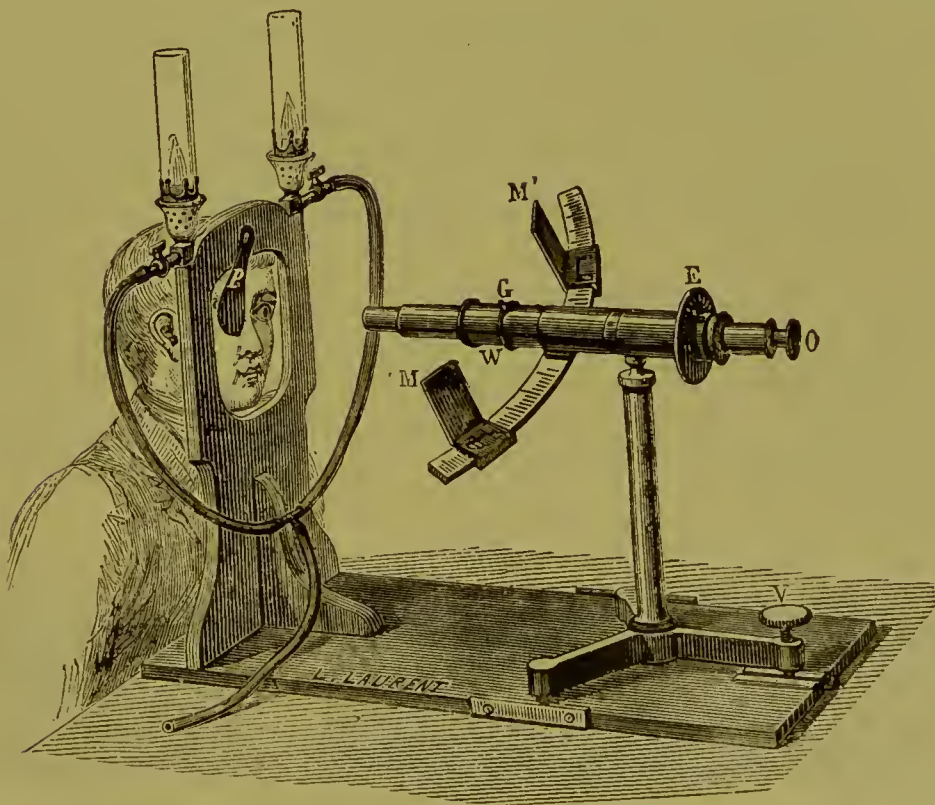


To calculate the configuration of the cornea, as approximately represented by a general ellipsoid (of three unequal axes), it is necessary to make several successive measurements of the image, as formed by reflection at different points taken at known angular distances from each other on the same corneal meridian. Each of these measurements involves taking the mean of four readings, representing as many observations; and the measurements must be repeated for different meridians. The complete examination of a single eye requires, therefore, numerous sésances.

III.—THE OPHTHALMOMETER OF JAVAL AND SCHIÖTZ (ORIGINAL MODEL, 1882).

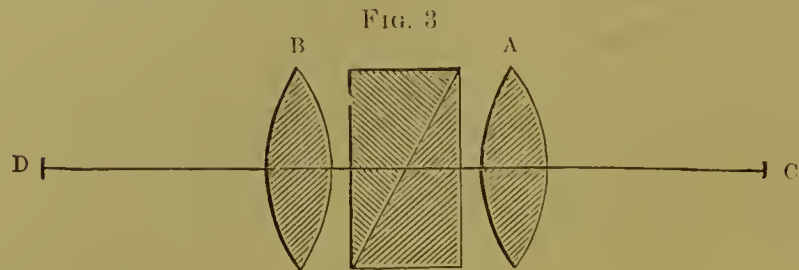
This ophthalmometer, as originally constructed by Laurent (Fig. 2), consists of a small inverting telescope mounted on a tripod, one of the feet

FIG. 2.



of the tripod sliding in a groove in the board which serves as a base for the instrument. By means of an elevating screw, which raises or lowers this foot of the tripod, the telescope is adjusted for the level of the observed eye; the necessary lateral adjustment is effected by moving the tripod on the board. The compound objective of the telescope (Fig. 3) consists of two convex lenses, between which is placed a doubly-refracting prism. Each of these lenses is of a focal length of twenty-nine centimetres. The eye to be measured is placed at *D*, the principal focus of the lens *B*. At *C*, the principal focus of the lens *A*, there is formed an inverted image of the same size as the erect image formed by reflection on the cornea; there is a spider-

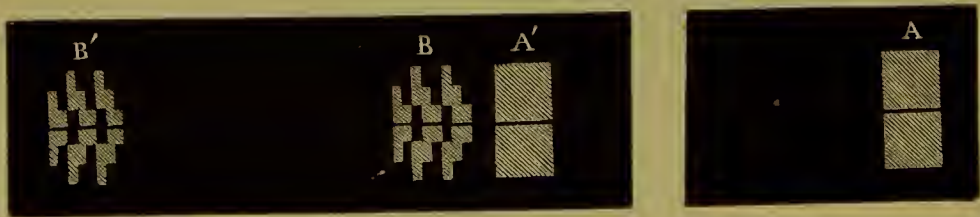
line sight at *C*, for which the ocular is focussed. A graduated arc of thirty-six centimetres' radius, whose centre of curvature falls a little beyond the focus *D* of the lens *B*, is fixed upon the tube of the telescope, so as to rotate



with the tube, about its axis. This arc is provided with a pointer, which indicates upon a stationary graduated circle *E* (Fig. 2) the angle through which the telescope and the arc are rotated. The effect of the doubly-refracting prism is to double the image formed by reflection on the cornea by exactly three millimetres.

It is important to choose the object of such form that its image as viewed by reflection on the cornea shall indicate at a glance the equivalent, in dioptres, of the difference in the refraction of the observed eye in its two principal meridians. The object which has been adopted as best fulfilling this requirement is a pair of white enamelled sights (*mires*), the one rectangular in shape, the other cut in a series of steps, each step measuring six millimetres. These two mires are arranged to slide upon the graduated arc; when properly adjusted, their images, doubled by the prism in the objective of the telescope, are seen reflected on the cornea of the observed eye, as shown in Fig. 4.<sup>1</sup> The arc is supposed to be set in the horizontal meridian, which is, as a rule, approximately the meridian of minimum curvature of the cornea.

FIG. 4.



The ophthalmometer of Javal and Schiötz, as compared with that of Helmholtz, presents several important advantages.

1. The suppression of the error of collimation, which is effected by the substitution of the doubly-refracting prism for the heliometric plates; the bundles of luminous rays by which the two images are formed are cones having a common circular base, instead of half-cones with semicircular bases.

2. The suppression of all calculation, enabling the observer to read directly, in dioptres, the refraction for each meridian.

<sup>1</sup> Fig. 4 shows the modified form of mires adopted in the new model (*vide* Fig. 5).

3. The reduction of the number of readings to one for each corneal meridian.

4. The possibility, in a case of astigmatism, of finding directly the meridians of maximum and minimum curvature, thereby effecting an enormous saving of time in this fundamental determination.

5. The doing away with the need of a special darkened room, the measurements being made either by daylight or by artificial light.

6. The smaller dimensions of the instrument, enabling it to be placed ready for use on any ordinary table.

7. A reduction of at least one-half in the cost of the instrument.<sup>1</sup>

#### IV.—THE OPHTHALMOMETER OF JAVAL AND SCHIÖTZ (LATEST MODEL, 1889).

The latest model (Figs. 5 and 6) differs in many respects from the earlier forms of the instrument.

The compound objective of the telescope is of increased diameter and of somewhat shorter focus, thus materially enhancing the brightness of the images.

The focussing of the cross-lines is regulated by a helical groove cut in the tube of the ocular, thus making it very easy for the observer to readjust the ocular to suit his own eye when the same instrument is used by different persons.

A large enamelled disk, upon which the degrees are conspicuously painted in inverted characters, stands just behind the arc which carries the mires. The degrees are numbered from  $0^{\circ}$  to  $180^{\circ}$ , and again from  $0^{\circ}$  to  $180^{\circ}$ , around the periphery of the disk, so that both extremities of the corneal meridian corresponding to any diameter of the disk are indicated by the same number. The inverted numerals appear erect and in correct position for reading from the image of the disk, when reversed by reflection on the cornea and viewed through the inverting telescope. The face of the disk is of black enamel, with concentric white circles whose radii represent tangents of arcs measured from the middle point of the arc which carries the mires; these circles correspond to differences of  $5^{\circ}$ , between the limits  $5^{\circ}$  and  $45^{\circ}$ . By directing the observed eye upon any designated point on one of these circles, the curvature of the cornea may be measured at any required angular distance from the point of intersection of the visual line. A scale marked on one of the diameters of the disk enables the instrument to be used also as a pupillometer. The special purpose subserved by the large disk is to enable the observer to read the angles of inclination of the meridians of greatest and least curvature directly from the reflected image. To this end, each of the mires is furnished with a short white pointer; a long white pointer, indicating the meridian at right

---

<sup>1</sup> For additional details, *vide* Transactions of the Seventh International Ophthalmological Congress, Heidelberg, 1888.

angles to that marked by the short pointer, is attached to the centre of the arc.

FIG. 5.

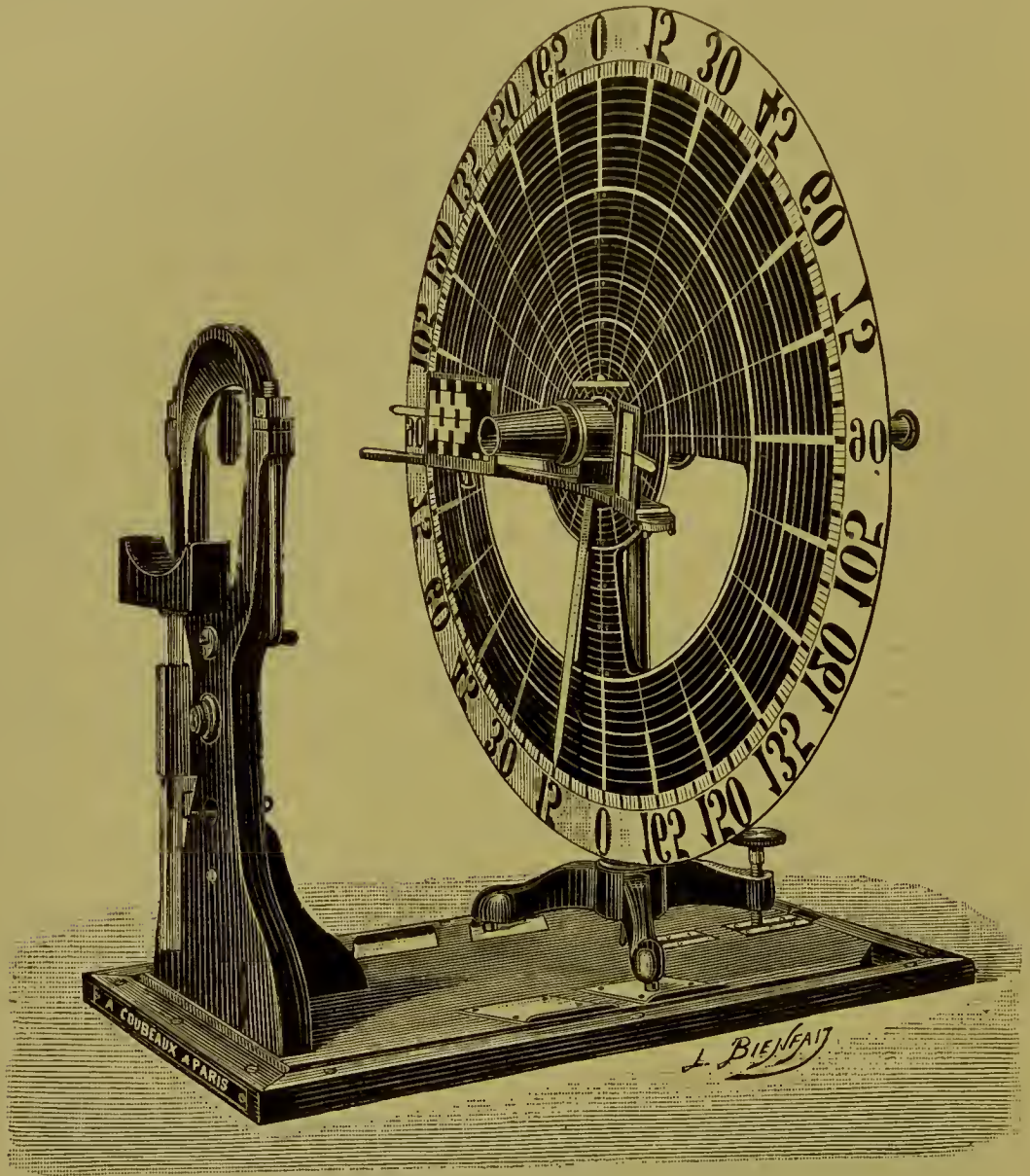
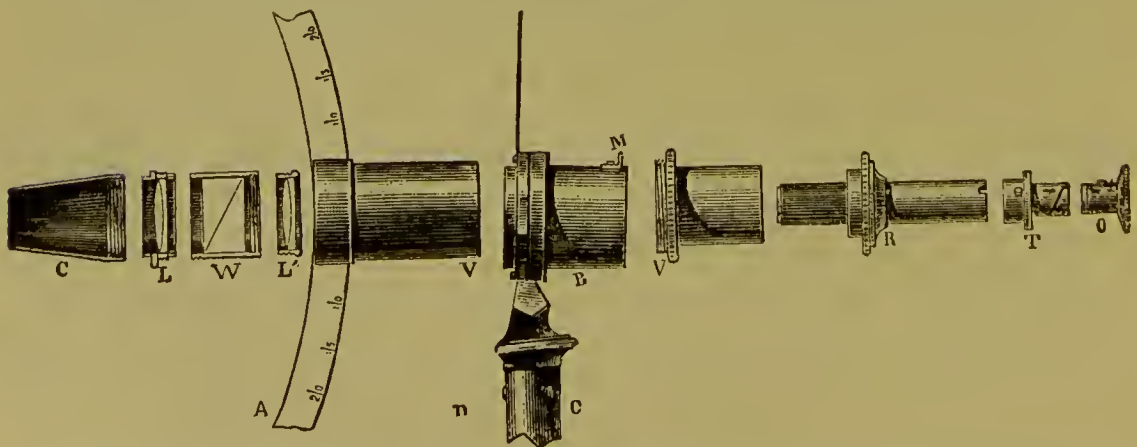


FIG. 6.

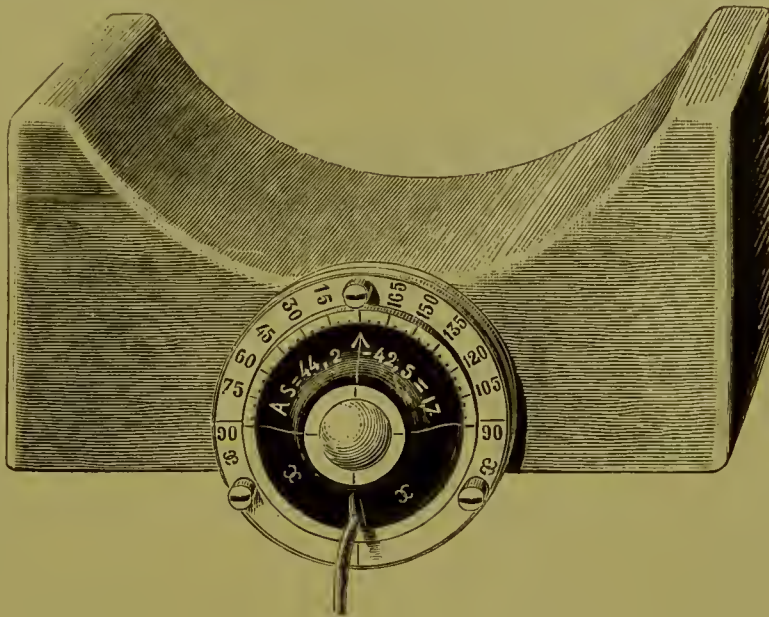


The white enamelled mires are mounted on a background of black

velvet. The rectangular mire is clamped in a fixed position on the arc; the contact of the doubled images is effected by moving the stepped mire along the arc.

A recent very useful addition to the ophthalmometer is the artificial astigmatic cornea (Fig. 7), which is made of polished metal, and mounted

FIG. 7.



on a small disk so as to rotate within a graduated circle, an arrow engraved on the movable disk serving to indicate the direction of the principal meridian of greatest curvature. When the arrow points to zero the meridian of greatest curvature is vertical, and the astigmatism is "according to the rule." For this meridian the reading of the overlapping steps indicates 44.2 dioptres, and for the other principal meridian 42.5 dioptres; the difference,  $44.2 - 42.5 \text{ D.} = 1.7 \text{ D.}$ , is the measure of the astigmatism of the artificial cornea.

The artificial cornea is of particular service to those who have occasion to verify the exactness of their instrument, especially in the case of instruments made elsewhere than in Paris. It is also of great value to students in learning the use of the ophthalmometer, enabling them to practise as long as they please without trying the endurance of a patient, and also, by reason of the great brilliancy of the images, to make the readings with ease and precision. The known value of the radii of curvature of the artificial cornea for the two principal meridians affords the means of controlling the accuracy of the measurement.

The use of the ophthalmometer includes several operations, all of which, with a little practice, may be executed very rapidly. In enumerating them we follow in the main Dr. Motais.<sup>1</sup>

1. We begin by rotating the tube of the ocular until we obtain a clear

<sup>1</sup> Mémoires d'Ophthalmométrie.

view of the cross-lines. The ocular should then be turned slowly to the left, so as to draw it out to the greatest extent that is compatible with seeing the lines sharply defined. This preliminary adjustment is of the greatest importance, as enabling the observer to see both the cross-lines and the mires without making use of his accommodation,—a very necessary precaution for securing accuracy of observation, besides saving needless fatigue. It is evident, therefore, that the adjustment of the ocular ought always to be the same for each particular observer, and that it should be made anew, in every case in which it has been disturbed, before entering upon the examination of an eye.

2. We next make sure that the head of the patient is firmly supported in the head-piece of the instrument, with the two eyes exactly on the same level; this condition is indispensable for ascertaining the precise direction of the principal meridians. The images of the mires are then brought into the field of the telescope by moving the entire instrument to the right or to the left on its base and making the necessary vertical adjustment by means of the elevating screw.

3. We have now to focus the instrument for the image. With one hand on the cast-iron tripod and the other on the elevating screw, we move the instrument forward or backward, according as the image is seen more or less sharply defined, until we obtain the sharpest definition possible; we next bring the image into the centre of the field by slight lateral movements of the instrument and by a further adjustment of the elevating screw. We now see, pictured upon the cornea of the observed eye, two overlapping images of the large disk. In the area defined by the overlapping portions of the two disks we see: (1) an image of the stepped mire crossed at its centre by a black guide-line, and (2) an image of the rectangular mire crossed also by a black line. We take account only of these central images, paying no attention to the lateral images of the mires which will be visible near the outer limits of the field when the instrument is properly centred.

4. When the eye under examination is astigmatic, we see that in certain positions of the arc the guide-lines on the mires do not lie in a continuous right line (Fig. 8). We bring them into line by rotating the arc, with the left hand, turning it to the right or to the left as may be necessary. At the same time, with the right hand, we move the stepped mire along the arc until its image is seen exactly in contact with that of the rectangular mire, as shown in Fig. 9. At this stage of the observation care should be taken to focus the image perfectly by moving the instrument as a whole, without disturbing the adjustment of the ocular which has been already focussed for its cross-lines. Particular care should be taken in this act of focussing to draw the entire instrument as far away from the observed eye as possible without impairing the definition of the mires. The doubled image of the disk, which lies in a plane a little behind the mires, will then appear slightly blurred.



each white step representing one dioptrie of astigmatism, and each fraction of a step representing a fraction of a dioptrie. For example, in the state of things represented by Fig. 10 we read one and a half dioptries.

Having noted the degree of astigmatism, we observe the direction of the principal meridian of greatest refraction by reading, from the numbers painted on the circumference of the disk, the angle indicated by the pointers on the mires in the second position, or by the long pointer in the first position of the instrument.

These two numbers are identical when the meridians of greatest and of least curvature are at right angles; if this is not the case, both numbers should be noted.

If, on turning the arc into the vertical position, the mires, instead of overlapping, are seen to recede from each other, the astigmatism is "contrary to the rule;" that is to say, the meridian of greatest curvature is horizontal or approximately horizontal.

In this case we may obtain an approximate reading by the aid of two small white squares (not shown in the figure) at the sides of the stepped mire, each of these squares representing a value of one dioptrie; but measurements made in this way are inexact, by reason of the defective achromatism of the instrument (the prism of Wollaston cannot be achromatized). It is preferable, therefore, in this second position of the arc, to bring the images again into contact by moving the stepped mire, and to read the number of dioptries of astigmatism after turning the instrument back to the first (horizontal or approximately horizontal) position.

It is sometimes desirable to obtain a closer approximation than is afforded by observing the overlapping of the steps; in such a case we may bring the images of the mires into the position of exact contact and take the reading from the graduation on the arc. If, as is generally the case, the rectangular mire is clamped at the division marked 20, we obtain the required value in dioptries, for the meridian for which the arc is set, by adding 20 to the reading of the stepped mire. We proceed in the same manner for the other principal meridian, and by subtracting one number from the other we obtain the measure of the astigmatism in dioptries.

Whenever, in passing to the measurement of the second eye, it is found necessary to make any considerable change in the elevating screw in order to bring the image into the field, it is a proof that the patient has inclined his head towards one or the other shoulder: in such a case the position of the head must be rectified and the measurement made anew from the beginning.

#### V.—OPHTHALMOMETRY AFTER CATARACT OPERATIONS.

Inasmuch as the eye, after it has been operated upon for cataract, has no longer any crystalline lens, it might naturally be assumed that in this particular case the information obtained from ophthalmometry would be most precise. In fact, the total astigmatism differs from the corneal astigmatism



so far only as the latter may be affected by astigmatism of the posterior surface of the cornea.

Nevertheless, even here we encounter certain minor difficulties. For instance, immediately after the operation of extraction there is developed a notable grade of inverse astigmatism,—that is, of astigmatism “contrary to the rule.” E. Javal, on examining an eye three days after an extraction, found an inverse astigmatism of seven dioptries. Little by little this astigmatism diminishes, until, in the course of two or three months, as the case may be, it is found to have fallen to between one and two dioptries, after which it undergoes little further change.

Scimemi and Weiss have sought the cause of this inverse astigmatism in an imperfect coaptation of the lips of the incision, in consequence of which the corneal curvature is diminished in the meridian perpendicular to the line of the cicatrix. As cicatrization progresses, the borders of the incision are gradually drawn closer together, but there still remains a certain difference in level, with some permanent flattening in the vertical meridian.

On the other hand, Laqueur<sup>1</sup> has reported a case in which an astigmatism of several dioptries “according to the rule” was found after a cataract operation. Although this case would seem to tell against the explanation just cited, it is nevertheless possible that in this particular instance there may have been a very high grade of astigmatism “according to the rule” before the operation, and that some part of this direct astigmatism may have persisted after the operation.

The question is, in fact, not altogether a simple one. Chibret has shown, and Ostwaldt has verified the observation, that the subjective examination not infrequently reveals an astigmatism of lower grade than that shown by the ophthalmometer. This may depend on the fact that the cornea is not a true ellipsoidal surface of three unequal axes with its vertex in the visual line: in other words, it will not do to ignore the angle *alpha*.

Again, when the operation has been combined with iridectomy, also in many cases of simple extraction, the pupil is notably deformed and displaced; in such a case the rays which go to form the retinal image must enter the eye through a more peripheral part of the cornea than that measured by the ophthalmometer, and in this way a new cause of error may arise.

Ostwaldt has called attention to another important fact. The ophthalmometric formula assumes for the cylindrical correcting glass a position of actual contact with the cornea; but in the higher grades of astigmatism, such as are often found after extraction, the distance of a centimetre or more from the cornea, at which the cylindrical glass is necessarily worn, must be taken into account in comparing the results obtained by ophthalmometry with those reached by subjective tests.

---

<sup>1</sup> Mémoires d'Ophthalmométrie, p. 140.

## VI.—EMPIRICAL FORMULA INDICATING THE TOTAL ASTIGMATISM.

It is not impossible that, when ophthalmometry shall have made sufficient progress, we may be able to construct a curve, or establish an empirical formula, by means of which the probable total astigmatism may be calculated from measurements of the corneal curvature as made with the ophthalmometer.

For the present we may adopt, as fairly in accord with the data derived from observation, a formula, of the first degree, of the form

$$y = a + bx.$$

Until we can take into account a greater number of elements than is now possible, it will be useless to introduce terms of a higher degree than the first. The formula suggests an analogy with anthropometric methods,—namely, having given a single measurement of the individual, such as the length of a finger, or the corneal astigmatism, to deduce from it other characteristics of the individual; in the present case the total astigmatism. In the formula which we have just indicated,  $y$  represents the total astigmatism and  $x$  the corneal astigmatism; it remains to find values for the two constants  $a$  and  $b$ .

The independent term  $a$  is probably determined in great part by astigmatism of the posterior surface of the cornea. According to Bull and Chibret, the value of this term is about three-fourths of a dioptrie in the inverse sense,—*i.e.*,  $-0.75$  D. In fact, when we measure an eye in which no subjective astigmatism can be detected, the statistics of Nordenson and of Schiötz show that there is generally present from 0.5 dioptrie to 0.75 dioptrie of corneal astigmatism “according to the rule,” and also that when the anterior surface of the cornea shows no astigmatism there is generally found an inverse subjective astigmatism of about 0.75 dioptrie. Numerous observations, made by different investigators, show that this astigmatism, which, to avoid prejudging the case, we shall call internal, and which is on the average equal to  $-0.75$  dioptrie, may be either greater or less than this mean by about one dioptrie. It appears, then, that the normally constructed eye shows a slight direct astigmatism of the anterior surface of the cornea, and that this direct corneal astigmatism is approximately neutralized by an inverse internal astigmatism of the same grade.

The factor  $b$ , whose value has also been determined empirically, depends, probably, upon a deformation of the crystalline lens, giving rise to an astigmatism proportional to that of the cornea,—to a sympathetic astigmatism, we might almost say. In this coefficient, which has been found to be equal to about 1.25, is included also the change in the effective value of the cylindrical glass due to its distance from the cornea when the eye is examined subjectively.

Inserting these numerical values of  $a$  and  $b$  in our formula, we have

$$y = -0.75 \text{ D.} + 1.25 x.$$

For the case in which the total astigmatism is equal to zero, the equation becomes

$$1.25 x - 0.75 \text{ D.} = 0.$$

$$x = \frac{0.75}{1.25} \text{ D.} = 0.6 \text{ D.}$$

If we assume a series of values for  $x$ , we obtain from our formula the following table, showing the relation between the corneal astigmatism and the total astigmatism :

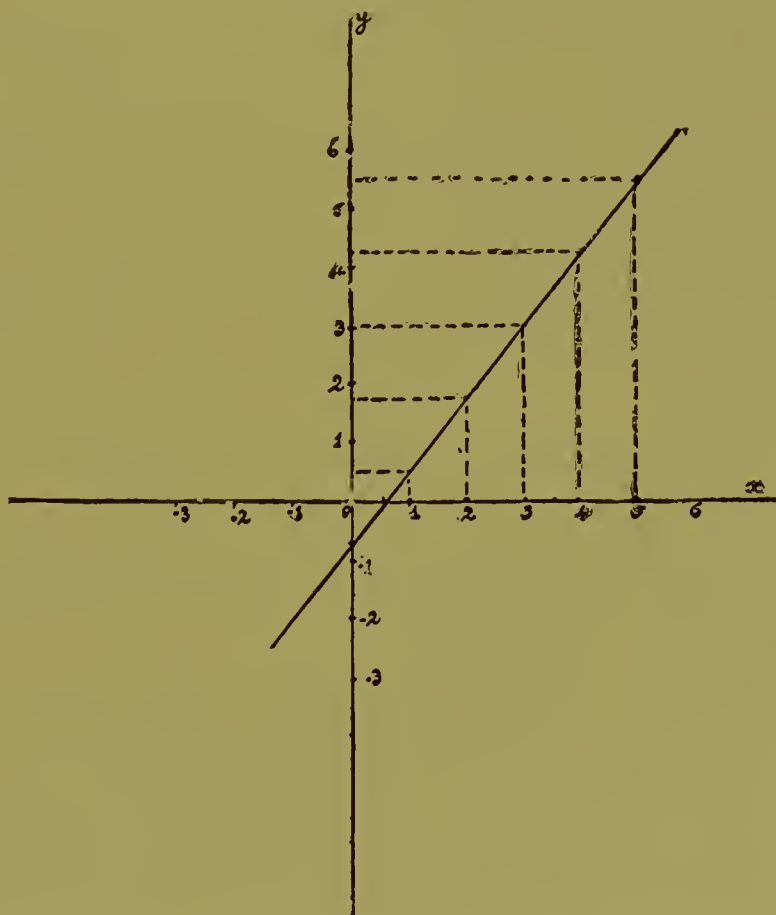
Corneal astigmatism ( $x$ ) =	0.	1.	2.	3.	4.	5.	6.
Total astigmatism ( $y$ ) =	-0.75	0.50	1.75	3.00	4.25	5.50	6.75

It will be observed that when the corneal astigmatism amounts to three dioptries the total astigmatism and the corneal astigmatism are equal.

Fig. 11 shows the construction of the curve (which, being of the first degree, is a straight line) corresponding to the formula

$$y = -0.75 \text{ D.} + 1.25 x.$$

FIG. 11.



In this figure the abscissas represent dioptries of corneal astigmatism and the ordinates dioptries of total astigmatism.

It goes without saying that neither the formula nor the values of the constants  $a$  and  $b$  are definitively established. As a first approximation to the truth, it may be said that the total astigmatism differs but little from the corneal astigmatism. A second approximation may be expressed by the

statement that in high grades of direct astigmatism, and generally in inverse astigmatism, the total astigmatism is greater than the corneal astigmatism.

For the present, as has been already stated, the observed facts are best expressed in the form of an equation of the first degree; but it is to be expected not only that the independent constant  $a$  and the coefficient  $b$  will have to be modified, but also that one or more terms will have to be added, by which the equation may be transformed into one of the second or even of a higher degree. It is not unreasonable to hope that, in the light of wider experience, the formula may be so perfected as to render real service to ophthalmology.

#### VII.—PRACTICAL APPLICATIONS.

When MM. E. Javal and H. Schiötz devised their practical ophthalmometer, they preferred to leave to their *confrères* the pleasure of setting forth its applications, thinking that it was not for them to insist upon the utility of their own instrument. The various researches which have been made by means of the ophthalmometer have been brought together in the volume entitled “*Mémoires d’Ophtalmométrie.*”

1. *Statistics.*—The first application of the new instrument was naturally in the examination of a considerable number of normal eyes. This was undertaken by Nordenson, who in 1882, at the *École Alsacienne*, examined the eyes of one hundred and fifty-eight pupils with the ophthalmometer, and also with the ophthalmoscope and with the optometer. In his memoir he states the following conclusions:

(*a*) Conformably to what has been stated by Donders, Mauthner, and others, in the case of eyes free from astigmatism the radius of corneal curvature is the same for the two eyes; the difference is generally so slight as not to be measurable.

(*b*) In children free from astigmatism the acuteness of vision is equal, as a rule, to fully once and a half the normal.

(*c*) Of emmetropes, nine out of ten show a measurable grade of astigmatism; the proportion is even greater in the case of hypermetropes, and greater still in the case of myopes.

(*d*) Of a total of two hundred and twenty-six children, sixty-nine had astigmatism of at least one dioptre in one eye,—that is to say, of a grade so high that it ought to have been reported to the parents, with a warning as to the necessity of calling in the aid of a specialist, either immediately or on the appearance of the first symptoms of myopia or of asthenopia.

(*e*) Of the same two hundred and twenty-six children, four had astigmatism of a grade higher than one and a half dioptres. These children ought at once to have been provided with suitable glasses.

(*f*) In young pupils, normal acuteness of vision is compatible with a corneal astigmatism of at least a dioptre and a half.

(*g*) The observations made upon the pupils of the *École Alsacienne* support the theory that in young persons the crystalline lens plays a part in the correction of astigmatism.

(h) The same observations appear also to confirm the statement, made long ago by Javal, that astigmatism predisposes to myopia; in fact, not a single case of myopia was found among the nine pupils who were entirely free from corneal astigmatism, whereas among the thirty-three myopes not one had eyes free from astigmatism, and two-thirds had at least a half-dioptic of this defect in both eyes.

The following year Schiötz conducted a similar statistical investigation upon nine hundred and sixty-nine eyes of pupils of the Cathedralschule at Christiania.

The percentage of eyes free from corneal astigmatism was found to be about fifteen; neglecting astigmatism of one-fourth or one-third dioptic, the percentage varies somewhat from this figure. The percentage of cases of corneal astigmatism "according to the rule" was found to be very near sixty-five, and of cases of corneal astigmatism "contrary to the rule" about fifteen; in about five per cent. of the eyes examined the direction of the principal meridians is given as oblique.

It is to be remarked that this last percentage varies considerably, according to different authors. Schiötz included in this category only those eyes whose principal meridians showed a variation of at least  $20^\circ$  from the vertical and horizontal.

Reuss, who examined the eyes of ninety-five young persons between seven and twenty years of age, states that the curvature of the cornea undergoes no change up to the age of twelve, but that beyond this age it shows a slight increase. Nordenson had not observed any such difference.

Schiötz followed with a special investigation of the corneal curvature in myopia, in hypermetropia, and in emmetropia; but in no one of these conditions did he discover any definite law.

Donders and Reuss found a somewhat greater radius of corneal curvature in myopia than in emmetropia. Mautlner, Nordenson, and Schiötz, on the other hand, found the radius of curvature a little less in myopia. All, except Reuss, have found the radius of curvature greater in hypermetropia than in emmetropia. It is, in fact, remarkable how greatly the radius of curvature may vary for the same refractive condition. In emmetropia the radii of curvature, as measured by Schiötz, varied between the limits 8.657 millimetres and 7.243 millimetres, or, in dioptics, between 38.8 D. and 45.3 D.,—a difference of not less than 6.5 D.

From these figures it would appear that variations in the radius of corneal curvature do not play any great rôle in determining the refraction.

A still more conclusive proof is afforded by observations made on anti-metropes. As a rule, in such persons we find the same radius of corneal curvature in both eyes, even when one of the eyes is highly myopic.

Referring to the work of Bourgeois and Tscherning,<sup>1</sup> it will be seen that the general measurements of the body, and especially the dimensions of the

---

<sup>1</sup> Mémoires d'Ophthalmométrie, p. 241.

head, show a positive relation to the radius of corneal curvature: thus, large men have larger eyes, with correspondingly greater radius of corneal curvature. The question of the existence of such a condition as myopia of curvature cannot, therefore, be settled until a coefficient expressing the relation between the size of the eyeball and some particular dimension of the head has been established for emmetropia. When this shall have been done it is almost certain that cases of myopia of curvature will be discovered.

2. *Troubles to which Astigmatism may give rise.*—To determine whether there exists any definite connection between astigmatism and other ocular affections, it was necessary first to collect statistics based on the examination of large numbers of diseased eyes.

The first investigation undertaken with a view to throwing light upon this question is that of Laqueur (1883); his paper, reprinted in the “*Mémoires d’Ophthalmométrie*,” merits a careful reading.

Attention should also be directed to the important work of Pfalz (1885), reprinted in the “*Mémoires*,” in which a positive relation is shown between glaucoma and astigmatism “contrary to the rule.”

Lastly, in numerous articles, in which he has occasionally gone somewhat further, perhaps, than the facts warrant, Martin, of Bordeaux, has called attention to the part played by astigmatism in a great number of ocular affections.

We give here a partial *résumé* of Martin’s conclusions:

(a) Whereas astigmatism of high grade is a cause of amblyopic vision, the lower grades of astigmatism are among the most frequent causes of asthenopia: this depends on the fact that the moderately astigmatic eye is constantly making efforts to see distinctly, whereas in the case of highly astigmatic eyes such efforts are unavailing, and are, therefore, not made.

(b) Astigmatism is often an active cause of relapsing keratitis, of the type generally regarded as serofulous. In young serofulous subjects relapses are much rarer when correcting cylindrical glasses are worn.

(c) Hemierania is often the result of astigmatism, generally of higher grade in the eye corresponding to the side of the head which is affected; the attacks are less frequent when correcting glasses are worn.

(d) In glaucomatous patients, astigmatism “contrary to the rule” is present in the enormous proportion of fifty per cent. of all cases (Pfalz has found a similar percentage); it has also been found that in certain cases of glaucoma an increase or a diminution in the grade of astigmatism goes hand in hand with increase or diminution of tension.

(e) Martin finds in astigmatism the cause of several ocular affections besides those which we have mentioned, but we must leave to others the task of verifying or refuting his conclusions.

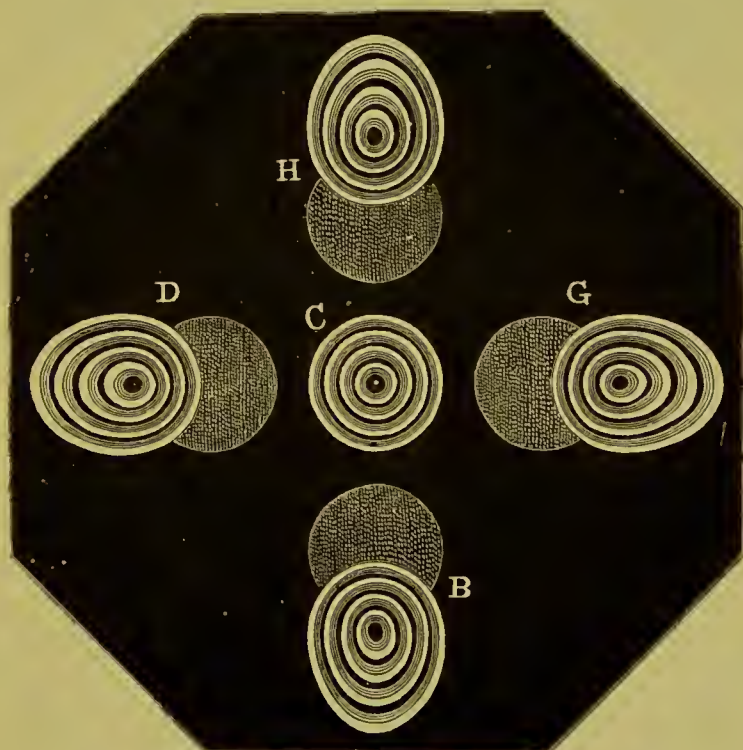
In view of facts now well established, it is certain that the correction of astigmatism deserves to be undertaken much oftener than is yet the practice in Europe, and that the greatest care ought to be taken both to ascertain the exact position of the principal meridians and to make sure

that the correcting glasses are accurately adjusted with respect to the direction of the axis of the cylinder.

VIII.—OPHTHALMOMETRY OF DIFFERENT PARTS OF THE ANTERIOR SURFACE OF THE CORNEA.

1. **Keratotomy.**—When we hold a keratoscopic disk in front of an eye, we see reflected on the cornea an image of the disk, which may be most advantageously observed by means of the ophthalmometer and preferably without the use of the doubly-refracting prism. The image of the disk is seen inverted, as is the case with all images seen through this instrument; and in the following illustrations (Figs. 12 to 15) the images have been drawn in the inverted position, in order to make it easy to compare them with those which the reader may observe for himself upon the living eye. The keratoscopic disk is made up of concentric circles, which, however, are

FIG. 12.



not equidistant, the radii of the several circles being calculated according to the law of tangents, so that when reflected on a cornea of spherical curvature they appear equidistant in the image.

Let us now see what variations the image presents (1) in the case of a cornea free from astigmatism, (2) in the case of a cornea which is the seat of regular astigmatism, and (3) in the case of irregular corneal astigmatism.

1. The cornea is assumed to be a surface of revolution about the visual axis. We know, according to J. L. Petit, that the surface of the cornea is not a segment of a sphere, but that it presents an ovoid configuration, the radius of curvature being less at the centre than towards the periphery. The keratoscopic image formed by reflection at the geometrical vertex of

such a cornea will, therefore, be made up of concentric circles, but these circles will not be equidistant, as would be the case if the cornea were of spherical curvature. An attempt has been made to indicate this appearance in the drawing of the central image *C* (Fig. 12).

Again, supposing the direction of the eye to remain unchanged, if we move the instrument so as to observe the keratoscopic image as formed by reflection on different lateral portions of the cornea, we shall obtain oval figures similar to the four images *H*, *B*, *D*, and *G* (Fig. 12).

Instead of changing the position of the instrument, it is easier to change the direction of the observed eye; this is, in fact, the way in which the images *H*, *B*, *D*, and *G* (Fig. 12) were drawn from observations made on the right eye of Dr. Nordenson, the eye having been turned through an angle of  $22.5^\circ$  downward, upward, to the left, and to the right, respectively.

It will be observed that in each of the four oval images the centre of the disk is displaced towards the centre of the cornea.

If our assumption that the cornea is a surface of revolution about the visual axis were strictly exact, the central image would be made up of perfect concentric circles, and the four oval figures would be perfectly symmetrical. This is, however, not exactly the case, inasmuch as the visual axis cuts the cornea at a greater or less angular distance from the vertex (angle *alpha*). Thus, it will be noticed that the oval image *G*, which is drawn as reflected at the nasal side of the cornea, appears somewhat more elongated than the image *D*, which is formed at the temporal side. If the drawing were absolutely exact, we should also be able to detect a very slight oval deformation of the circles of the central image.

2. The cornea is supposed to be astigmatic. From what has gone before it is easy to see that in the case of a cornea whose curvature is regularly astigmatic "according to the rule" the central image *C* will be made up of concentric ovals with the major axis horizontal, and that the images *G* and *D* will appear conspicuously elongated horizontally. In the case of the images *H* and *B*, on the other hand, there will be two possible positions on the vertical meridian at which the increase in the vertical diameter of the image, due to the changing curvature of the cornea, will approximately neutralize the horizontal elongation as shown in the central image *C*. In these positions the images *H* and *B* will appear nearly circular.

As we have no drawing showing exactly this state of things, we give (Fig. 13) a representation of the images as seen in the left eye of Dr. E. Javal (corneal astigmatism "contrary to the rule" of about one and a half dioptries). The concentric rings of the central image *C* are slightly elliptical, with the major axis vertical, while the images *H* and *B* differ only in degree from the corresponding images in Fig. 12. On the other hand, the lateral figures *G* and *D*, resembling as they do the central image *C*, suggest a configuration of the cornea approaching much more nearly that of a torus than of an ellipsoid of three unequal axes. (In this figure the peripheral images are drawn with the eye turned through a smaller angle,



in each of the four directions indicated, than in Fig. 12 and in the other figures of this series.)

FIG. 13.

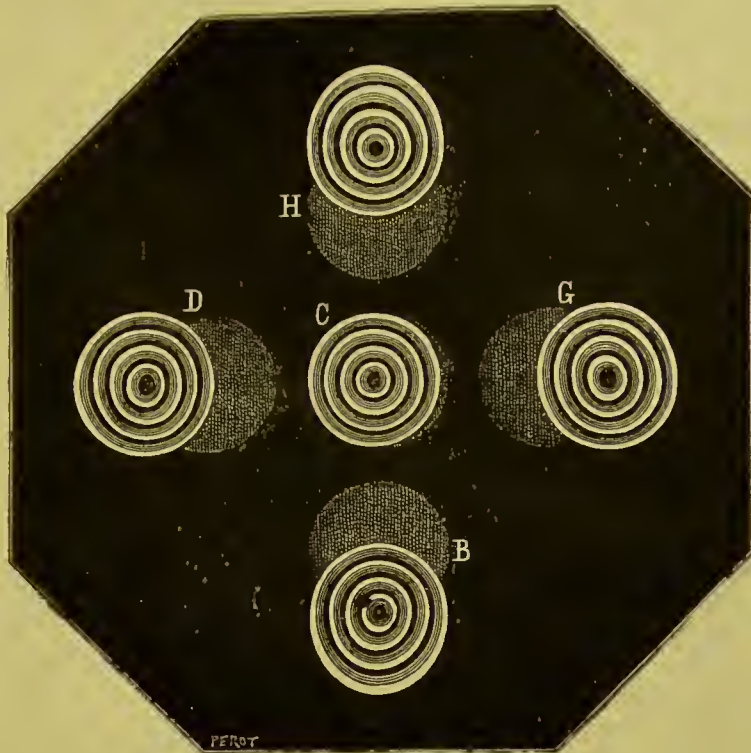
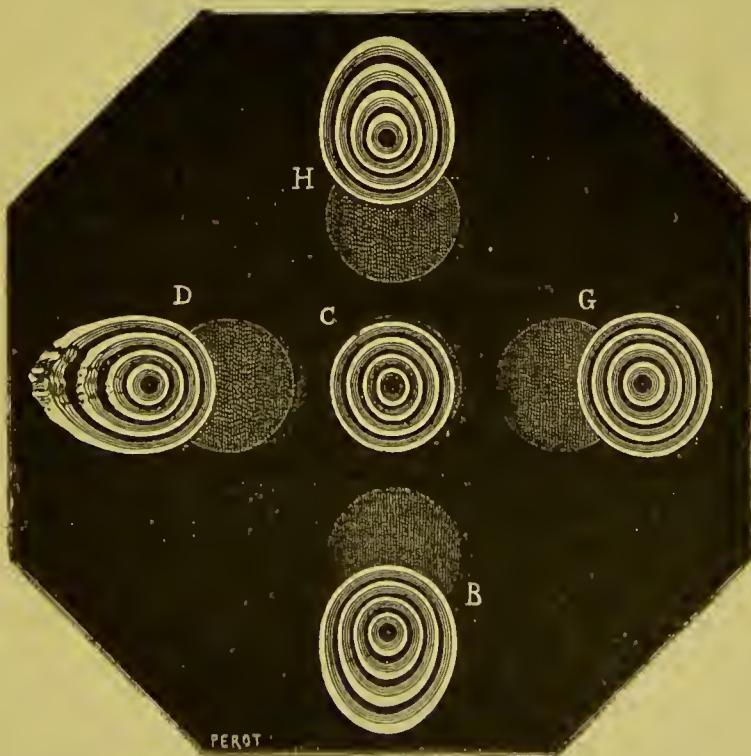


Fig. 14 shows the four images reflected on the same cornea when the eye is turned through an angle of  $22.5^\circ$ . The very dissimilar images *G*

FIG. 14.

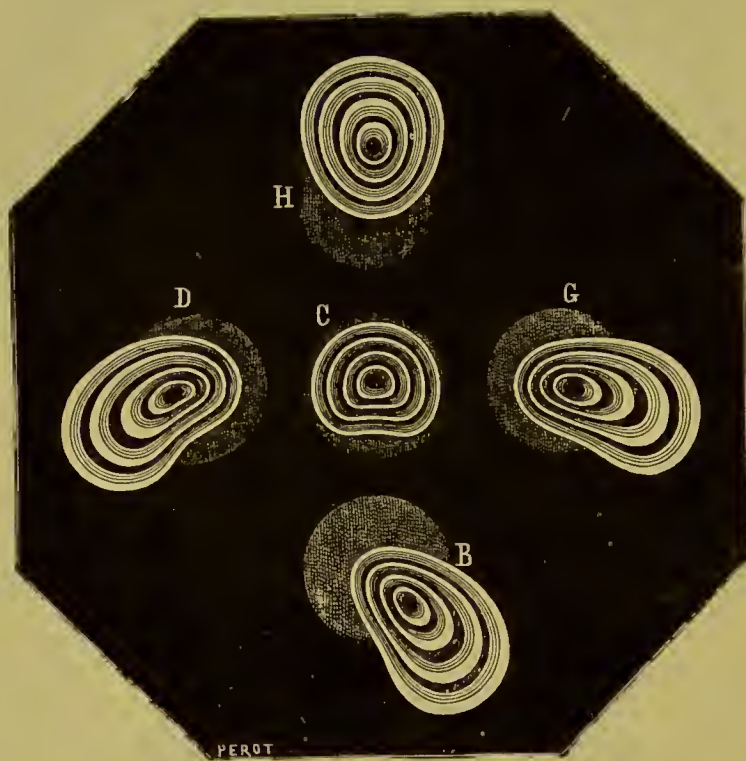


and *D* now show a marked asymmetry of the cornea with reference to a vertical plane passing through the visual axis. (The ribbon-like appearance

shown in the left-hand image is due to the image encroaching a little upon the scleral border.)

3. Fig. 15 shows the keratoseopic images in a case of irregular astigmatism,—the eye of Dr. T. The conspicuous distortion of the images *B*, *G*, and *D*, together with the flattening of the circles in the central image, shows at a glance that this eye has suffered at some former period from a keratitis which has given rise to a local deformation of the cornea, although without visibly affecting its polish and its transparency.

FIG. 15.



2. Diagrammatic Representation of Corneal Astigmatism.—The keratoseopic images would furnish a complete record both of the corneal astigmatism and of the decentration of the visual axis, if only it were practicable to fix them by instantaneous photography and measure them under the microscope. Until this shall have been accomplished we must depend upon the ophthalmometer to obtain an approximate idea of the form of the anterior surface of the cornea; but whereas the keratoseopic image shows the complete topography of the portion of the cornea on which it is reflected, a single measurement made with the ophthalmometer gives information regarding only two points lying in some particular corneal section.

It has already been stated that the curvature of the cornea is more pronounced at the centre than at the periphery, and that its general configuration approaches more or less closely that of the small end of an egg. Hereafter, in speaking of the radius of curvature of a cornea it will be understood that we do not mean the curvature at the actual vertex, but rather the radius of a sphere tangent to the cornea in a small circle *AA'* (Fig. 16) when the cornea is a surface of revolution, or the radius of a circle

tangent to a corneal meridian at two opposite points  $A$ ,  $A'$ , when the cornea is astigmatic;  $A$  and  $A'$  being the two points on the cornea at which the mires are reflected. When the ophthalmometer is fitted with a prism of weak doubling power, this tangent sphere or circle passes so near to the curved surface at  $C$  that we may, without material error, take its radius as equivalent to the radius of curvature of the cornea in the zone on which the mires are reflected.

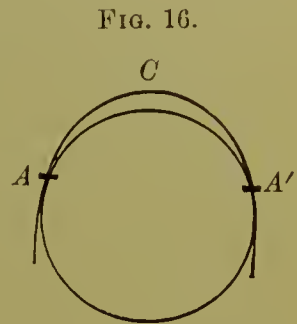


FIG. 16.

Sulzer<sup>1</sup> has measured with the ophthalmometer, in a large number of eyes, both the corneal curvature and the astigmatism at points taken at successive angular distances of  $5^\circ$  from the visual centre on the two principal meridians. In plotting his results he has made use of a form of diagram in which the angular distances of the several observed points from the visual axis and the number of dioptres of curvature found at these points are laid off on rectangular co-ordinates; the same system of co-ordinates is made to serve for both meridians by interchanging the ordinates and abscissas.

Referring to the images of the keratoscopic disk, the measurements of Sulzer represent only the length and breadth of the oval image, but give no information regarding the position of the image of the centre of the disk with reference to the two extremities of the oval. More satisfactory measurements might probably be made by using a prism of half the doubling power, such as is now furnished as one of the accessories of the ophthalmometer.

We reproduce from Sulzer the diagram of the right eye of Dr. K. (Fig. 17), as presenting an example of somewhat unusual decentration.

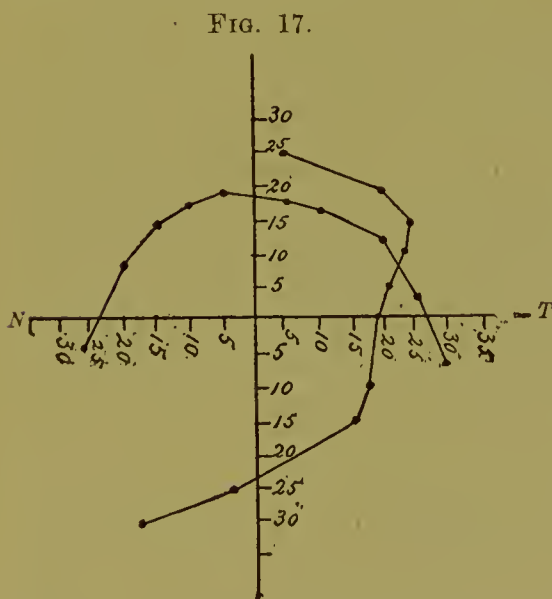


FIG. 17.

the lower corneal margin; from this summit the corneal curvature flattens abruptly towards the upper limbus, but very gradually in the opposite

In the horizontal meridian the curvature is seen to be nearly regular; but this is by no means the case with the vertical meridian. In the horizontal meridian the point of maximum curvature falls  $5^\circ$  to the nasal side of the visual line, or  $20^\circ$  from the nasal and  $35^\circ$  from the temporal border of the cornea; towards the nasal side the curvature diminishes rapidly, but more slowly towards the temporal side. In the vertical meridian the point of maximum curvature falls  $15^\circ$  above the visual line, or  $10^\circ$  from the upper and  $45^\circ$  from

<sup>1</sup> Archives d'Ophthalmologie, xi. 5.

direction through an angular distance of  $30^\circ$ , after which it again flattens abruptly towards the lower limbus.

The conclusions drawn by Sulzer from his investigations on the form of the cornea are briefly as follows :

(a) The central region of the cornea differs but little in its configuration from a segment of a sphere (leaving astigmatism out of account).

(b) At a certain distance from the point of intersection of the visual line with the cornea—*i.e.*, at an average angular distance of  $15^\circ$  (which in the case of a cornea of mean curvature corresponds to a linear distance of two millimetres)—the curvature begins abruptly to diminish. From this point to its periphery the corneal surface shows a progressively decreasing curvature assimilable to that which would be presented by a succession of ellipsoids of progressively increasing eccentricity.

(c) Whether we assume the point of intersection of the visual line with the corneal surface, or the point of maximum corneal curvature, as representing the centre of the cornea, the corneal curvature does not diminish proportionally to the distance from this centre, and this whether the distance be measured on the two principal meridians or on the two halves of the same principal meridian; in other words, the cornea is not in any sense a surface of symmetrical curvature.

Astigmatism is only a particular form of corneal asymmetry, though, fortunately, the most common one, since in the more complicated cases cylindrical glasses afford but an imperfect correction of the visual defect.

A rational interpretation of these results, and perhaps also an explanation of the existence of the angle *alpha* in the human eye, may be found in the fact that most animals have the eyes directed laterally. From this point of view, the slight lateral deviation of the ocular axes in man may be regarded as a phenomenon of incomplete evolution.

#### IX.—OPHTHALMOMETRY OF THE POSTERIOR SURFACE OF THE CORNEA.

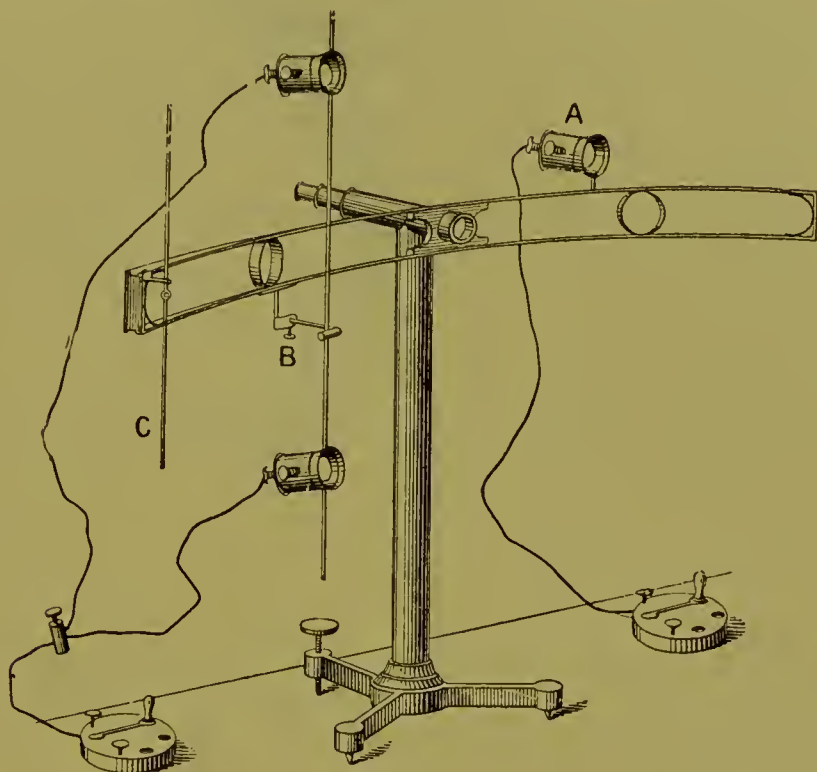
In the foregoing pages we have considered the measurement, by means of the ophthalmometer, of the curvature of the anterior surface of the cornea. But the objective determination of the total astigmatism involves also the measurement of the posterior corneal surface and of the two surfaces of the crystalline lens. The ophthalmophakometer of Dr. Tscherning (1890) supplies a means of making these measurements. The instrument resembles, in a general way, the ophthalmometer of Javal and Schiötz, omitting the doubly-refracting prism.

A metallic arc (Fig. 18) of eighty-six centimetres' radius, graduated to tenths of a degree, is arranged to turn upon the axis of a small telescope through which the images of three small incandescent lamps, carried by the arc, are observed by reflection at the two surfaces of the cornea and at the two surfaces of the crystalline lens; the eye to be measured is stationed at the centre of curvature of the metallic arc.

Arranged to slide along this arc are (1) a carrier *A*, bearing an incan-

descent lamp of six volts, (2) a carrier *B*, bearing a rod perpendicular to the plane of the arc, to each end of which is fixed a smaller incandescent lamp, and (3) a carrier *C*, also bearing a rod perpendicular to the plane of the arc, upon which slides a small brilliant ball serving as a point of fixation for the observed eye. Each of these carriers is fitted with a pointer to mark its angular distance from the centre of the arc.

FIG. 18.



Each of the lamps is enclosed in a small brass tube, which is fitted in front with a strong plano-convex lens arranged to slide in and out, so as to render the pencils of rays from the incandescent filament either parallel or convergent, at will.

The instrument is designed for observing and measuring the catoptric images formed by the feebly reflecting surfaces within the eye,—namely, the erect and inverted images of Purkinje (formed by reflection at the anterior and at the posterior surface, respectively, of the crystalline lens) and the faint erect image formed by the posterior surface of the cornea.

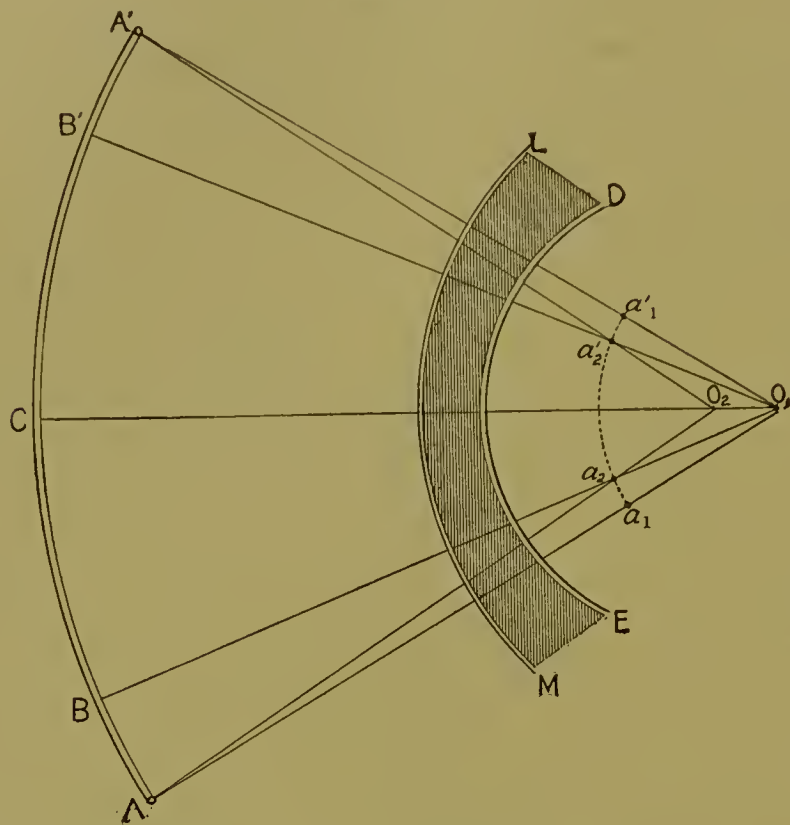
The image of the more powerful lamp *A* is viewed as formed by reflection at the posterior surface of the cornea; the images of the two smaller lamps *B*, reflected on the anterior surface of the cornea, are brought into line with the first image by sliding the carrier on the arc.

The eye to be measured is directed upon the centre of the objective of the telescope, and the carrier *A*, with its lamp, is moved along the arc until the fainter image  $a_2$  is seen clearly defined and at a little distance from the brighter image  $a_1$  (Fig. 19).

The two weaker lamps carried by the rod *B* are now lighted, and the

carrier is moved along the arc (on the same side) until the two images formed by reflection at the anterior surface of the cornea are seen exactly

FIG. 19.

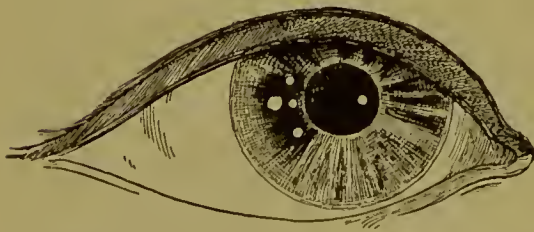


in line with the image  $a_2$ ; the line  $O_1B$  will then pass through  $a_2$ . The positions of the carriers  $A$  and  $B$  on the arc are then noted.

Fig. 20 shows the relative positions of the three images as they appear at this stage of the observation.

The brighter image  $a_1$  of the lamp  $A$  is seen to the left, and the feebler image of  $A$ , formed by reflection at the posterior surface of the cornea, is

FIG. 20.



seen between and in line with the two images of the lamps  $B$ . The bright point seen to the right, in the field of the pupil, is the image of the lamp  $A$ , formed by reflection at the posterior surface of the crystalline lens.

Two measurements are required in order to obtain the necessary data

for determining the radius of curvature of the posterior surface of the cornea, the one with the lamps in the positions  $A$  and  $B$ , and the other with the lamps in the symmetrical positions  $A'$  and  $B'$ .

Referring to Fig. 19,  $a_2a'_2$  represents both the length of the image of  $AA'$ , as formed by reflection at the posterior corneal surface, and the length of the image of  $BB'$ , as formed by reflection at the anterior corneal surface.

The difference in distance of  $O_1$ , the centre of curvature of the anterior corneal surface, and  $O_2$ , the centre of curvature of the posterior surface,

from the middle point of the arc at  $C$  is so small that we may, without sensible error, assume for both a common value  $l$ , which by the construction of the instrument is equal to eighty-six centimetres.

Now, the radius of curvature of a convex mirror of small angular diameter is found (see page 114, *ante*) from the proportion

$$\frac{\text{Half radius of curvature}}{\text{length of image}} = \frac{\text{distance of object}}{\text{length of object}}$$

Designating the radius of curvature of the anterior surface of the cornea by  $v_1$ , and the radius of the posterior surface by  $v_2$ , we have for the anterior corneal surface

$$\frac{\frac{1}{2} v_1}{a_2 a'_2} = \frac{l}{BB'}$$

and for the posterior corneal surface

$$\frac{\frac{1}{2} v_2}{a_2 a'_2} = \frac{l}{AA'}$$

Dividing the first of these equations by the second, member by member,

$$\begin{aligned} \frac{v_1}{v_2} &= \frac{AA'}{BB'} \\ v_2 &= v_1 \cdot \frac{BB'}{AA'} \end{aligned}$$

$AA'$  and  $BB'$  are found from the readings on the arc; the value of  $v_1$  is calculated from measurements of the anterior surface of the cornea, made by means of the ophthalmometer.

The measurements of Tscherning give the average result

$$v_2 = 0.77 v_1.$$

This corresponds to a value of about six millimetres for the radius of curvature of the posterior surface of the cornea, or about two millimetres less than that of the anterior surface; but, by reason of the fact that the refractive index of the corneal substance is only slightly greater than that of the aqueous humor, the refraction at this surface is small in amount. The cornea is, therefore, in effect a concave lens of feeble power; its value is probably about  $-0.5$  D.

The posterior surface of the cornea is found to diminish in curvature from the centre towards the periphery, as in the case of the anterior surface, and in cases of corneal asymmetry it appears also, as might be expected, to follow the asymmetry of the anterior surface. As a concave lens of asymmetrical curvature, the effect of the cornea is, therefore, to compensate in some degree the astigmatism of the anterior corneal surface as measured by the ophthalmometer.

The maximum compensation due to this cause, so far as has been observed, is about 1 D. (as estimated for an eye in which the total astigmatism measured about 6 D.).

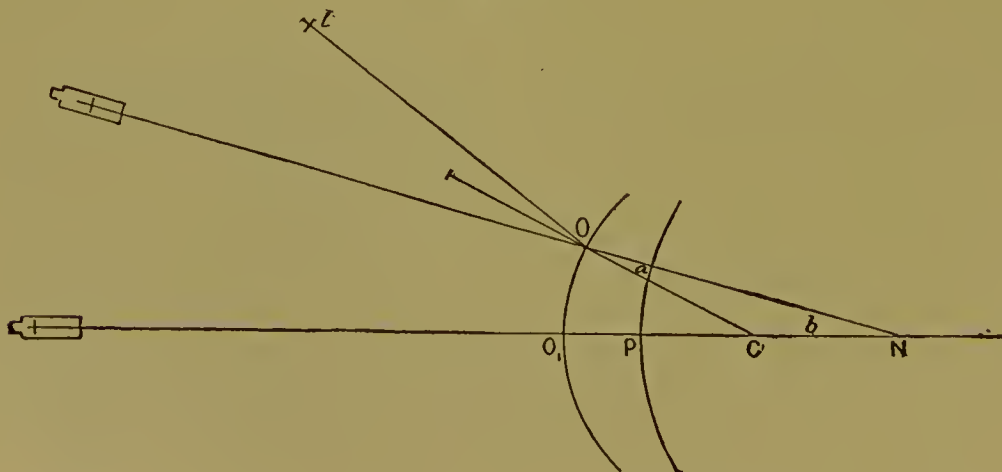
## X.—OPHTHALMOMETRY OF THE CRYSTALLINE LENS.

The ophthalmophakometer serves also for measuring the curvature and the position of the anterior surface of the crystalline lens; but first it is to be remarked that the catoptric image to be measured is formed by rays which before reflection have been refracted at the two surfaces of the cornea, and which after reflection are again refracted at the same two surfaces before reaching the eye of the observer. The measurements made with the ophthalmophakometer represent, therefore, not the actual position and curvature of the observed reflecting surface, but its position and curvature as modified by these refractions. From the measurements deduced from the observation of this *apparent* reflecting surface (whose position is about one-half millimetre in front of the actual position of the anterior lens-surface, and whose radius of curvature is about fifteen millimetres instead of about ten millimetres) the true position and radius of curvature of the anterior lens-surface may be easily calculated.

In the case of the posterior lens-surface, the apparent position and curvature are further modified by refraction at the anterior lens-surface; but, owing to the fact that the posterior lens-surface lies very near the nodal point of the eye, the apparent surface differs but little from the true surface.

The observation of the anterior lens-surface is begun by directing the eye to be measured upon a fixed point, and then moving the telescope until the image of a lamp situated in its axis, as formed by reflection at the anterior lens-surface, is seen in the centre of the field in line with and midway between the images of two smaller lamps stationed at opposite sides of the tube of the telescope and reflected on the cornea. In this position the axis of the telescope is normal both to the cornea and to the anterior lens-surface, and consequently passes through their two centres of curvature  $C$  and  $N$  (Fig. 21). The position of the telescope on the arc is then noted, after

FIG. 21.



which it is moved along the arc to a new position, whose angular distance from the previous position we will designate by  $b$ , taking care to keep the image formed by reflection at the anterior lens-surface always in the centre







# PRISMS AND PRISMOMETRY.

BY WILLIAM S. DENNETT, M.D.,

Surgeon to the New York Eye and Ear Infirmary, New York City, New York, U.S.A.

IN optics, any medium which is homogeneous and transparent, and separated from surrounding media by at least two non-parallel plane surfaces, is called a *prism*. The two plane refracting surfaces are the *sides* of the prism, and the dihedral angle formed by them and in which the substance of the prism is situated is the *edge*, the *apex*, or what may more properly be termed the *refracting angle* of the prism. A section of the prism so made as to be perpendicular to both sides is a *principal section*, and lies in a *principal plane*. It is convenient also to call the plane that bisects the refracting angle the *plane of the prism*, and to term any line which is perpendicular to the edge of the prism and contained in this plane a *base-apex line*.<sup>1</sup>

A prism whose refracting angle is infinitely small has parallel sides and is called a *plate*. The direction of a ray of light which passes through a prism is, in general, changed at each of the refracting surfaces. The resulting change of direction is called the *deviation*, or,

when necessary to distinguish it from the deviation produced by a single surface, the word "total" is prefixed.

Fig. 1 represents a principal section of the prism  $ARB$ .  $M$  and  $N$  are perpendiculars to the refracting surfaces, and they meet at  $L$ . Let  $D$  be the total deviation, then

$$D = \phi - \phi' + \psi - \psi'. \quad (1)$$

By similar triangles and Euclid I. 32,

$$R = \phi' + \psi', \quad (2)$$

from which immediately follows

$$D = \phi + \psi - R. \quad (3)$$

<sup>1</sup> There will be no occasion to consider any prism whose refracting angle is greater than  $180^\circ$ , for in such a case the containing medium becomes the prism, and *vice versa*.

Snell's law gives

$$\begin{aligned} \sin \phi &= \mu \sin \phi', \\ \sin \psi &= \mu \sin \psi'; \end{aligned} \quad (4)$$

and if it is remembered that these relations hold good whether the angles designated by  $\phi$ ,  $\psi$ , etc., are those which the ray makes with the normal to the refracting surface or with any plane passing through that normal, the whole theory of the passage of a ray through a prism in any direction is obtained. It thus appears that  $D$ , the deviation, that for which the prism is most frequently used, is a function of the three variables  $\mu$ ,  $\phi$ , and  $R$ . In matters that concern the reader,  $\mu$  is practically constant, and, unless otherwise stated, is assumed to be 1.54. The manufacturer of spectacles often assumes it to be 1.50, though it is almost always between 1.52 and 1.55.  $\phi$  is usually so conditioned as to be a simple function of  $R$ , and variations in the deviation are obtained by variation of  $R$ .

The expression for  $D$  in terms of  $R$  is thus found :

$$\text{From (3)} \quad \psi = R + D - \phi, \quad (5)$$

$$\text{From (2)} \quad \psi' = R - \phi', \quad (6)$$

$$\text{From (4)} \quad \sin \{ (R + D) - \phi \} = \mu \sin (R - \phi'), \quad (7)$$

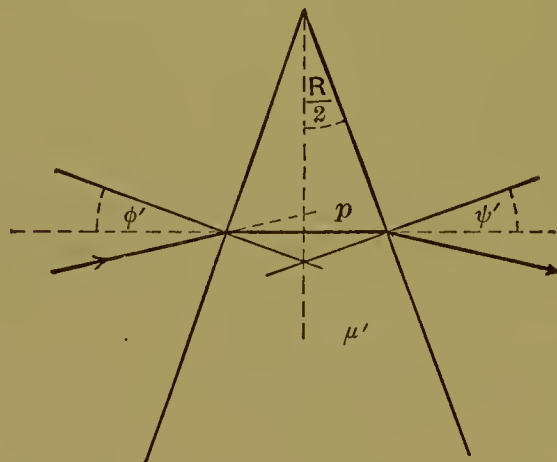
and hence

$$\sin (R + D) \cos \phi - \cos (R + D) \sin \phi = \mu \sin R \cos \phi' - \mu \cos R \sin \phi'. \quad (8)$$

If this formula is to be applied only to prisms so thin that, without sensible error, the arc  $R$  or  $(R + D)$  can be substituted for its sine, and 1 for its cosine, it will be much simplified and readily reduced to

$$D = R \left\{ \frac{\mu \cos \phi'}{\cos \phi} - 1 \right\}. \quad (9)$$

FIG. 2.



This is a useful formula, for where the angles  $\phi$  and  $\phi'$  are small, so that their cosines may be considered equal to 1, the ratio of their cosines is also equal to 1, and it becomes

$$D = (\mu - 1) R, \quad (10)$$

by which formula deviation is ordinarily estimated. Another formula which is of frequent use will by Fig. 2 be shown to be true, since  $\varphi' =$  one-half  $R$  gives the deviation at the minimum position,—*i.e.*, when  $\varphi = \psi$

$$\frac{D}{2} = \sin^{-1} \left( \mu \sin \frac{R}{2} \right) - \frac{R}{2}. \tag{11}$$

If, also, all the fractions in (11) are replaced by their numerators, the equation gives the deviation at position of perpendicular incidence, thus :

$$D = \sin^{-1} (\mu \sin R) - R; \tag{12}$$

and a simple transposition of (11) gives

$$\mu = \frac{\sin \frac{R + D}{2}}{\frac{R}{2}}, \tag{13}$$

which is the common rule for obtaining the index of refraction where the refracting angle is known.

The end for which the prism is most frequently used in clinical ophthalmology is the angular displacement of objects seen through it. All objects are seen by means of small pencils whose various directions are indicated by their axial rays, and consequently the laws that govern the displacements sought are the common laws of optics which have just been considered in their application to the path of the ray through the prism. But, as the adventitious phenomena of color and distortion are so great as to be in some cases prohibitory, it is necessary to consider these. Three things must be known about the passage of light through a plane refracting surface before the significance of the preceding paragraphs can be understood. (See Fig. 3.) These three things are,—

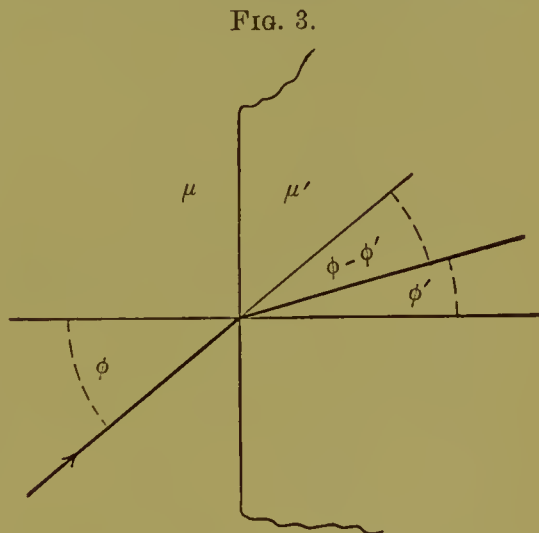


FIG. 3.

(a) The greater the angle of incidence the greater is the angle of refraction.

(b) The greater the angle of incidence the greater is the deviation.

(c) The greater the angle of incidence the greater is the change in the angle of deviation produced by any change in the angle of incidence.

The truth of (a) is established by experience, which has given the well-known general formula, of which (4) are special cases,

$$\mu \sin \phi = \mu' \sin \phi'. \tag{14}$$

$\varphi$  being the angle of incidence,  $\varphi'$  the angle of refraction, and  $\mu$  the recip-

recal of the velocity of light along the path indicated, the deviation produced is of course  $\varphi - \varphi'$ . Differentiating (14) by logarithms gives

$$\frac{d\varphi}{d\varphi'} = \frac{\tan\varphi}{\tan\varphi'}, \quad (15)$$

and in the case where  $\varphi$  is greater than  $\varphi'$ , since neither  $\varphi$  nor  $\varphi'$  can be greater than a right angle, both members of Equation (2) are improper fractions, and consequently  $d(\varphi - \varphi')$  is positive, which proves (b).

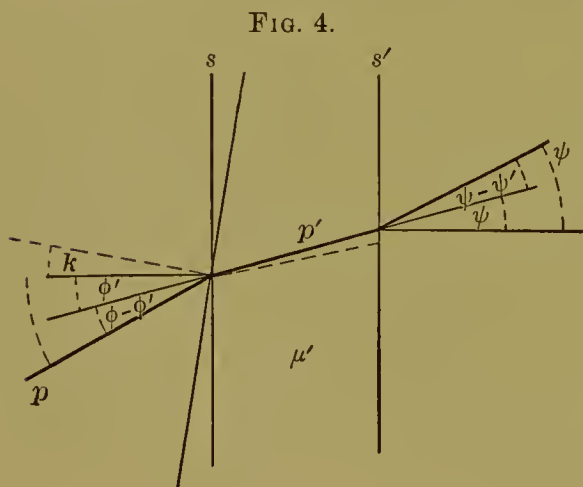
Equation (15) is easily transformed to

$$\left(\frac{d\varphi}{d\varphi'}\right)^2 = \frac{\left(\frac{\mu'}{\mu}\right)^2 - 1}{\cos^2\varphi} + 1, \quad (16)$$

which establishes the truth of (c).

Experience has shown, as indeed (14) indicates, that the path of the light ray is reversible; and so, since the incident ray can always be taken on that side of the surface which renders  $\frac{\mu'}{\mu}$  greater than 1, the above demonstration may be considered general.

The principle of reversibility of path insures also that there can be no deviation when light passes through two parallel plane surfaces which separate one medium from another. Hence, by considering a plate as a prism



of infinitely small refracting angle, it can be proved (Fig. 4) that where the index of refraction of the prism is greater than that of the surrounding medium, a ray or thin pencil is bent away from the refracting angle. Let  $p'$  be the path of a ray of light passing in principal section in either direction through  $\mu'$ . As  $s$  is parallel to  $s'$ ,  $R = 0$ , and that  $(\varphi - \varphi') + (\psi - \psi') = 0$  follows from (14), and there is no resulting deviation.

Let  $p'$  be the same ray after  $s$  has been moved towards  $s'$ , so that the surfaces are no longer parallel, and the plate becomes a prism of finite angle. The change in the position of  $s$  increases  $\varphi'$ , that  $\varphi$  is increased follows from (a), and that  $(\varphi - \varphi')$  is increased follows from (b). Attention to the signs of the quantities involved will show that  $(\varphi - \varphi') + (\psi - \psi')$  is positive, and that, in accordance with (c),  $(\varphi - \varphi')$  increases faster and faster till the critical angle is reached and refraction ceases. This proof is general, since  $p'$  might have been taken in any direction and followed either way.

A prism whose index of refraction is higher than that of the surrounding medium produces the least deviation in that ray or pencil which in its passage through the substance of the prism makes equal angles with its two sides. Let  $p$  in Fig. 2 be the ray making equal angles with the sides

of the prism  $\mu'$ , the deviation will be the same on the two sides of the prism and have the same sign. When, however, the direction of  $p$  is gradually changed clockwise, on account of (b), both  $\varphi'$  and  $\varphi$  will be decreased, and  $\psi'$  and  $\psi$  will be increased, but on account of (c) the increase ( $\psi - \psi'$ ) will be greater than the decrease ( $\varphi - \varphi'$ ), so that the total deviation will be increased. The analytical proof of this is not difficult. It is shown<sup>1</sup> that in (1)  $D$  is a function of one independent variable,—say  $\varphi'$ ,—and that the first differential coefficient is equal to 0 when  $\varphi' = \psi'$ , and that the second differential coefficient is positive when  $\mu' > \mu$ .

The above proofs apply to refraction in a principal plane. It may be well to add, omitting proofs, for which see Heath,<sup>2</sup> that if incidence takes place in any other plane the deviation is greater if the index of refraction is greater than 1, and that the planes of incidence and emergence, though parallel, are not coincident, the “fault” being the same as would be caused by a plate in the plane of the prism having a thickness such that its two sides contained respectively the points of incidence and emergence of the ray under consideration.

Though the preceding equations “contain the whole theory of refraction through a prism,” and are sufficient to determine the angular displacement of any point seen through it, the illusions concerning distance and the distortions of outline caused by prismatic glasses cannot be understood without a consideration of the effect of plane surfaces on convergent and divergent pencils. Parallel rays of monochromatic light pass through plane surfaces unchanged, except in direction; but pencils, besides being altered in focal length, cease to be homocentric. The interesting demonstration of this must be omitted for lack of space.

It is a well-known fact that if the radiant is in the denser medium the rays become the normals to an ellipse, but if it is in the rarer medium they become the normals to a hyperbola.<sup>3</sup> The first case is illustrated by Fig. 5, the second by Fig. 6,  $O$  being the radiant and  $OP$  the ray which is perpendicular to the refracting surface. In each figure is seen also the same pencil as changed by refraction, the perpendicular ray alone being unaltered in its position, and the focus  $O$  being replaced by a caustic  $O'A$ , which in Fig. 5 is the evolute of an ellipse and in Fig. 6 is the evolute of a hyperbola. These figures are drawn to scale and are accurate for a glass of index 1.54. It will also be seen that the point  $O$ , being the radiant, is not represented by a point after refraction, but by a long line, the caustic. As the size of the pupil, however, is such as to limit vision to the use of pencils of not much over five degrees, a point from which a five-degree pencil emerges will, after refraction at the plane surface, be approximately represented by a point after refraction, and the divergence

<sup>1</sup> Michie, Elements of Wave-Motion, New York, 1891, p. 164.

<sup>2</sup> Heath, Geometrical Optics, Cambridge, 1887, p. 31, § 28.

<sup>3</sup> Heath (p. 121, art. 106). The Theory of Light, by Thomas Preston, London, 1890. (Example 1, p. 89.)

of the pencil thus refracted depends very much upon the obliquity of incidence on the refracting surface. The figures will illustrate what it is inconvenient here to prove,—viz., that the part of the pencil whose rays are nearest to perpendicular is the part that is altered the least in focal length, but that the alteration is even here very material, as the relative length of the pencil, before and after refraction, at perpendicular incidence, is the same as the relative index of the second medium to the first. It is a necessary consequence of (a), (b), and (c), previously demonstrated, that for oblique pencils the lengthening or shortening increases in an ever-increasing ratio, so that a small change of inclination of a pencil that is inclined at forty degrees will for glass produce double the effect that an equal change would have produced at one degree.

The principle of reversibility also insures that if the angle of refraction in Fig. 5 equals the angle of incidence in Fig. 6, whatever the original angle of incidence, the effect on a pencil which passes through

FIG. 5.

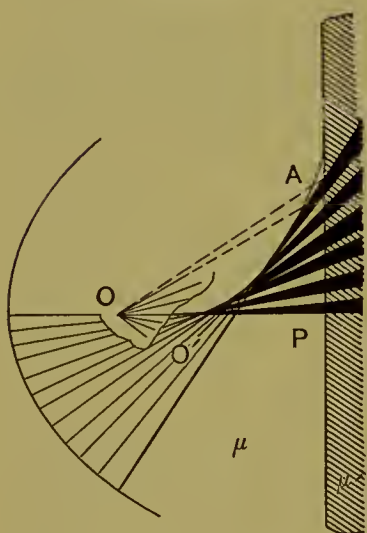
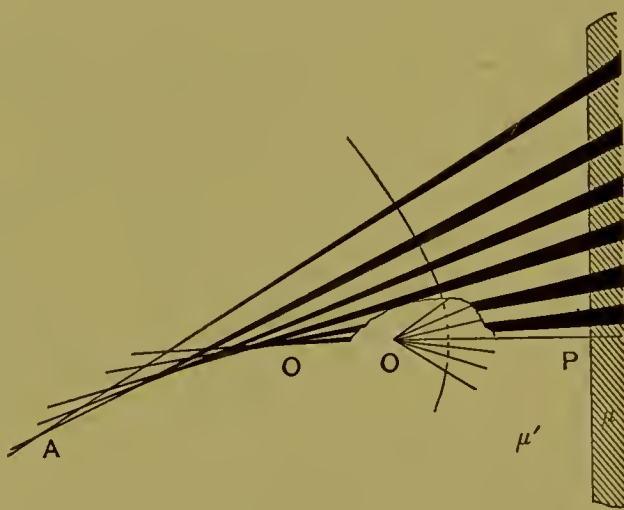


FIG. 6.



both these refracting surfaces successively will be nothing but a comparatively unimportant translation which is due to the thickness of the glass, and which in ordinarily weak lenses may be ignored. Remembering this, and also knowing that the magnification produced in simple lenses is directly proportional to the length of the pencils that connect object and image with refracting surfaces, it becomes plain that that part of the field which is seen at the position of minimum deviation will appear unchanged in size, since the lengthening of the pencil at the first surface is exactly compensated by the shortening at the second surface.

That part of the field which is seen by pencils that pass through the prism at the position of perpendicular incidence—*i.e.*, incidence at right angles to the front surface—will be magnified, because this change of position has shortened the refracted pencil at both the front and the back surfaces, which is just the effect that a convex lens would have had. Those objects seen at perpendicular emergence, however, will be minified.



Still greater departure from the position of minimum deviation will increase at an increasing rate the magnification or minification, as the case may be.

Perhaps a single concrete example will best show the utility of these last paragraphs. Imagine a patient wearing before each eye a prism of four degrees' refracting angle, the edges vertical, the base-apex lines coincident the one with the other, the bases towards the nose, the index of the glass, for simplicity, 1.50. Let the patient's face be directed towards a surface finely tessellated with vertical and horizontal lines, at a distance of one and three-quarters metres, and perpendicular to the line of direct vision. By equation (10), the deviation produced in rays or pencils nearly perpendicular to the plane of the prism is

$$D = R(\mu - 1) = 4^\circ (1.50 - 1) = 2^\circ. \quad (17)$$

Since .03, half the interpupillary distance, is the tangent of one degree to radius 1.75, rays coming from that square which is directly in front of the patient will enter either eye by passing symmetrically through the prism. This square, as previously shown, will be unchanged in size. To see it, however, each eye must be directed outward, since one degree, or half the deviation, will remove the apparent place of the central square from the median line to a position that lies directly in front of the eye that sees it, while the other half of the displacement will move it one degree farther outward.

Considering now the apparent size and shape of all the squares, as seen by the right eye, the horizontal line dividing the upper from the lower half of the field will be straight. The reason for this is that rays entering the eye from this line pass through the prism in a principal section, and by Snell's law cannot pass out of this plane. As previously shown, the squares increase in width as they go from left to right, the rate of change being slowest at the median line; also, each square will look a little too tall, and the height of the squares will increase from right to left, the rate also increasing. This increase necessitates that the line along the top of the squares in the upper half of the field shall run up-hill to the right, and the increasing rate indicates that it will be a curved line. The lower half of the field will be a looking-glass picture of the upper half, and the picture seen by the left eye will be a looking-glass picture of that seen by the right eye. This, however, does not combine all the distorting effects of the prisms, for, as has been shown by Dr. John Green,<sup>1</sup> differences in the retinal picture, as seen by the two eyes, which are so slight as to be otherwise unnoticeable, may by their stereoscopic effect produce marked delusions: so that, besides the shear that would be given to nearly every square on the checker-board, the superposition of the right and left pictures, thus symmetrically distorted, would by the stereoscopic effect cause the wall to appear convex towards the observer, while the opposite impression of distance and size

<sup>1</sup> Trans. Amer. Oph. Soc., 1889, p. 449.

would be produced on the middle squares by the divergence of the visual axes. Thus, the exact appearance of a wall or of any other object, as viewed through prismatic glasses of the simplest character, would be determined by factors not entirely consistent among themselves, each one of which would be weighted by the previous experience and habits of observation of the individual wearing the glasses.

The color-phenomena attending the use of prismatic glasses are not difficult to understand. One may imagine every object in the field made up of the three layers of Young-Helmholtz primaries, and that in any change of outline due to distortion or displacement the violet is moved a little more, while the red is moved a little less, than the green, the result being that uniform surfaces are unchanged in hue, but that outlines of light surfaces on the side towards which the displacement is effected are fringed with violet and those opposite are fringed with red.

Turning now to matters of nomenclature and manipulation, it will be conformable to the requirements of the art if for unit prism one is selected whose deviating power is, within reasonable limits, the smallest useful increment. That which common consent and long usage have made familiar, and which is as good as can be chosen, is a prism whose index is within two or three one-hundredths of 1.54, and whose refracting angle is equal to one degree. This prism gives a deviation of a very little over five-tenths of a degree, an amount as small as is ordinarily required. The scale to which this unit naturally belongs, though faulty, is still used, and prisms are designated thus, Pr. 1°, Pr. 2°, Pr. 3°, etc., the numeral, unless otherwise stated, referring to the refracting angle of the material of which the prism is made.

The numbers of the scale can be connected by no sufficiently simple law with equal increments of deviation. This is seen by reference to column 1 of the subjoined table, or to equation (11), by which that part of the table was made.

TABLE I.

TABLE SHOWING THE DEVIATION PRODUCED BY THE REFRACTING ANGLE SERIES, BY CENTRADS, BY PRISM-DIOPTERS, AND BY METRE-ANGLES.

Refracting Angle.	Deviation.	Centrad.	Deviation.	Prism-Di- opter.	Deviation.	Metre-An- gle.	Deviation.
Pr. 1° = 0° 32' 20"		1∇ = 0° 34' 22"		1Δ = 0° 34' 22" +		1 <sup>m</sup> = 1° 43' 6"	For interocular distance of .06.
2° = 1° 4' 50"		2∇ = 1° 8' 45"		2Δ = 1° 9'		2 <sup>m</sup> = 3° 26' 12"	
3° = 1° 37' 20"		3∇ = 1° 43' 7"		3Δ = 1° 43'		3 <sup>m</sup> = 5° 9' 18"	
4° = 2° 1' 20"		4∇ = 2° 17' 30"		4Δ = 2° 17'		4 <sup>m</sup> = 6° 52' 24"	
5° = 2° 42' 8"		5∇ = 2° 51' 53"		5Δ = 2° 52'		5 <sup>m</sup> = 8° 30' 5"	
6° = 3° 14' 50"		6∇ = 3° 26' 15"		6Δ = 3° 26'			For interocular distance of .064.
7° = 3° 47' 20"		7∇ = 4° 0' 38"		7Δ = 4°			
8° = 4° 20' 2"		8∇ = 4° 33' 10"		8Δ = 4° 34'			
9° = 4° 51' 40"		9∇ = 5° 9' 23"		9Δ = 5° 12'			
10° = 5° 23' 40"		10∇ = 5° 43' 46"		10Δ = 5° 43'		1 <sup>m</sup> = 1° 50'	
11° = 5° 58' 20"		11∇ = 6° 18' 8"		11Δ = 6° 17'		2 <sup>m</sup> = 3° 40' 43"	
12° = 6° 32'		12∇ = 6° 52' 31"		12Δ = 6° 51'		3 <sup>m</sup> = 5° 30' 41"	
13° = 7° 4' 50"		13∇ = 7° 26' 53"		13Δ = 7° 24'		4 <sup>m</sup> = 7° 21' 23"	
14° = 7° 38'		14∇ = 8° 1' 16"		14Δ = 7° 58'		5 <sup>m</sup> = 9° 12' 3"	
15° = 8° 11' 32"		15∇ = 8° 35' 39"		15Δ = 8° 32'			

It is true that in other branches of physical science prisms are thus designated, and the refinements of practice are not such that gross errors can arise from assuming the scale to be one that gives uniform differences of deviations, since other considerations confine the choice very much to that part of the scale where such an assumption is approximately correct.

The deviation is commonly thought of as half the refracting angle. For ordinary glass this result is too small, and demands the addition of six to eight per cent. of itself for prisms under three degrees, eight to ten per cent. for others under twenty degrees, and eleven per cent. for thirty degrees.

In 1887 the sentiment in favor of a better scale, as voiced by Dr. Jackson, received the attention of the American Ophthalmological Society, whose committee recommended that prisms used in ophthalmological practice be designated by the number of degrees of minimum deviation, and that this should be made evident by writing after the number of the prism a small *d*, thus, Pr.  $3^{\circ} d$ , meaning a prism of such a refracting angle that it would cause a deviation of three degrees in any ray passing symmetrically through it.

A set of prisms numbered by this system would be reduced to the old system by being multiplied by two. The resulting error may be seen and corrected by reference to the preceding table.

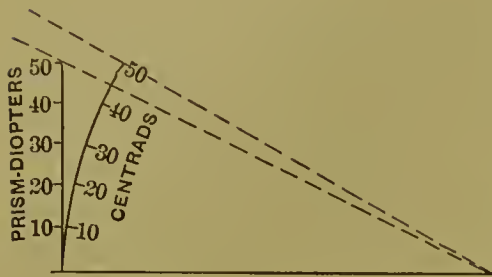
In 1889 the writer suggested measuring the deviation in hundredths of the radius, so that the unit of the old and that of the new scale would be alike and their multiples so nearly alike as to be ordinarily interchangeable. The new unit was called a "centrad," the etymology being obvious and the nomenclature and general method in keeping with the "C. G. S." system. In this system, as in the last, the deviation is equicrescent, but the unit has one-half the value of the unit in the last, and coincides exactly with the unit of the first for glass of index 1.57+. For ordinary glass, No. 1 of the centrad system deflects the ray two and one-third minutes more than No. 1 of the old system,—a discrepancy of less than seven per cent., and entirely negligible in practice. The greater the refracting angle the more nearly do the old and the radian systems coincide, until (for glass of index 1.54) Pr.  $33^{\circ}$  and Cr. 33 (thirty-three centrads) become the same.

The recommendations of the author concerning the kind of glass to be used and the position for which the deviation should be calculated were unimportant and perhaps irrelevant. The radical part of the system is that its consecutive numbers give equal increments of deviation, in units of an already well established scale, which measures the angle instead of a transcendental function of the angle, and which is theoretically unobjectionable. Its advantage is that it so nearly resembles the old system that the change is practically one of symbol only, and can be made without mental effort, or, being made, will be quite undiscoverable to those who find mental effort objectionable.

In 1890, in the *Archives of Ophthalmology*, Mr. Prentice suggested a system of prisms in which the unit called the "prism-diopter" produces

a deviation whose tangent is one-hundredth of the radius, the higher numbers designating deviations that produce corresponding increments of

FIG. 7.



tangent. This system has no advantage over the last, and was not introduced for any such supposed advantage, but came into existence independently in answer to the same demand, which it very well satisfies. The theoretical difference is shown by Fig. 7. The actual difference between corresponding numbers of the two scales is the difference between the

tangent and the arc of the same number of hundredth-radians. The practical difference within the limits of actual use is hard to see.<sup>1</sup>

In 1891 the Ophthalmic Section of the American Medical Association passed a resolution recommending the adoption of the centrad unit and scale, and equally with that up to 20° the prism-diopter.

Recently Mr. Prentice has recommended that in writing for prism-diopters, instead of P.-D. 2 and P.-D. 3, as formerly, they be indicated by replacing the old sign of degrees by a capital delta, thus, 2<sup>Δ</sup>, 3<sup>Δ</sup>, etc. This is an excellent idea; and, as uniformity of method in writing for prisms is desirable by whatever system they are measured, it is here suggested that the following symbolism be adopted, viz.:

Refracting angle system.—Pr. 1°, Pr. 2°, etc. (as formerly).

Angle of deviation system.—Pr. 1<sup>d</sup>, Pr. 2<sup>d</sup>, etc.

Centrad system.—Pr. 1<sup>∇</sup>, Pr. 2<sup>∇</sup>, etc.<sup>2</sup>

Prism-diopter system.—Pr. 1<sup>Δ</sup>, Pr. 2<sup>Δ</sup>, etc.

Metre-angle system.—Pr. 1<sup>m</sup>, Pr. 2<sup>m</sup>, etc.

The "metre-angle" of Nagel has also been suggested as a prism unit. It is the angle which each visual axis makes with the median plane when the point of fixation is at one metre's distance from the centre of rotation of each globe. It was introduced as a measure of convergence, and is so chosen that while for an emmetrope the *punctum remotum* is equal to the focal distance of the glass that is worn, the fusion angle may be equal also to the strength of that glass in diopters. This relation should not be lost sight of, as it is capable of accurate expression in any individual case. The value of the metre-angle, however, depends on the distance between the

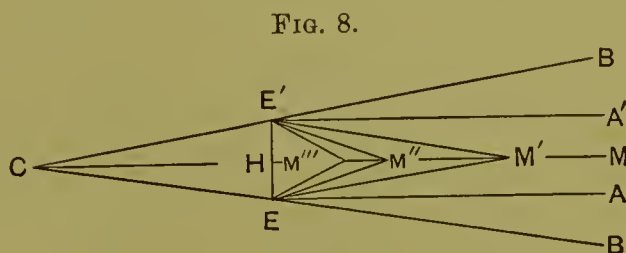
<sup>1</sup> It cannot be seen on the prism-diopter scale published by its author in 1891, as the lines are so thick that they much more than cover any discrepancy between the two scales, the origin being supposed at the left-hand edge of the 0 line. In the centrad scale published by Meyrowitz in 1895, where the origin and measurements are calculated from the lower edge of the lines, the prism-diopter falls behind the centrad exactly the width of one line (1.6 millimetres) at the end of the scale. Indeed, if a scale were made with the finest visible lines showing centrads and prism-diopters up to No. 10, only with perfectly good vision and exceptional illumination could the No. 10 lines of the two scales be distinguished the one from the other; all lower numbers would be incapable of resolution.

<sup>2</sup> "∇," a symbol much used in other branches of science.

eyes, and is subject to considerable variation; the average is near  $1^{\circ} 45'$ . In adults it does not often vary  $10'$  (ten per cent.) from this magnitude.

One might without great error assume that six centimetres is the correct interocular distance, and then the following convenient relations would be approximately established:  $1$  metre-angle  $= 1.71^{\circ} = 1^{\circ} 43' 6''$ , a deviation produced by  $\text{Pr. } 1^{\text{m}} = \text{Pr. } 3^{\circ} = \text{Pr. } 1.50^{\text{d}} = \text{Pr. } 3^{\text{v}} = \text{Pr. } 3^{\text{A}}$ . This is accurate enough for clinical work as now conducted, though  $.64$  is a better average interocular distance for adults.

In Fig. 8,  $E$  and  $E'$  represent the eyes;  $M$ ,  $M'$ , and  $M''$  are both far points and fusion points for myopia of one, two, and three diopters;  $EMH$ ,  $EM'H$ , and  $EM''H$  are metre-angles one, two, and three, respectively. They have the same numbers as the glasses that will place the far points of emmetropic eyes



at their apices, and are consequently capable of calculation by the same formulæ. The foci for hypermetropic eyes are minus quantities, and may be represented behind the line  $EE'$  in the same way, where  $C$  is the far point for hypermetropia of one diopter, and  $ECH$  is the corresponding metre-angle, which of course must have a minus sign.

The constants of a prism may be determined with great precision on the table of the spectrometer, and there are numbers of instruments for the measurement of angles that are or can be applied to this purpose. As ophthalmologists, however, we thus far have little need of any but the most easily attainable accuracy. We are required to estimate within reasonable limits the prismatic effect of decentred lenses, either spherical or cylindrical, or both, and to determine also the strength and position of a prism on either of whose sides one of the above surfaces has been ground. This leads to the remark that a decentred spherical lens differs in no respect from a sphero-prism; and though there are combinations of prism and cylinder that cannot be obtained by displacement of the cylinder, those that are so obtained are identical with the prism of like degree on whose side has been ground a cylindrical surface.

Spherical lenses, as ordinarily used, have the centres of their spherical surfaces and all their cardinal points on the axis of the optical system to which they belong. When simply decentred, these points are all translated at right angles to the axis of the system. The direction and distance from the original to the final position of the optical centre of either of these points measures the amount of the decentring.

That point on the decentred lens through which the axis of the system passes is frequently spoken of as its *geometrical centre*, a term which is so often accurately descriptive as to warrant its future use in that sense, unless otherwise specified.

It seems hardly necessary to remark that the prismatic action obtained from any glass other than a simple prism is dependent somewhat on the point that is chosen for its geometrical centre. Hence, in many cases, the work of the manufacturer is corrected or modified, and, indeed, often the whole prismatic action is obtained, by attention to the position of the lens, and this attention is necessary in any of the curved lenses, whether to produce or to prevent the deviations that are dependent upon decentring.

Neglecting spherical aberration, which in spectacle lenses is slight, the one ray that passes through the spherical lens unrefracted is crossed at the focal plane by every ray which before refraction was parallel to it: hence the deviation is always directly towards or away from the optical centre of the lens, through which centre the base-apex line must necessarily pass. So, also, when the geometrical and optical centres of the lens do not coincide, the base-apex line connects them, and the apex is towards the thinnest part of the glass. The refracting angle of the equivalent prism must, from geometrical considerations, be the angle formed by planes tangent to the front and back surfaces at the geometrical centre.

A cylindrical lens is decentred only in proportion as the axis of the cylindrical surface is removed from the optical centre of the system: a translation that is parallel to the axis of the cylinder has no prismatic effect.

In case of a sphero-cylinder, the effect of decentring must be calculated for each surface independently. The base-apex line for the spherical side may be determined as just stated, and its direction is the direction of translation. The base-apex line of the cylindrical side, however, is not in general the same as this: it is always in the direction of a line that is perpendicular at the same time to the axis of the cylinder and to the axis of the system. Such a line measures the amount and marks the direction of the decentring of the cylindrical side of the lens. Its length is equal to the distance which the lens has been moved, multiplied by the sine of the angle which the direction of translation makes with the axis of the cylinder.

The joint prismatic effect of the front and back surfaces of a decentred compound lens cannot be obtained by simple addition. The deviations must be treated as vectors (see Fig. 16), or combined in accordance with formulæ (23) and (24) below.

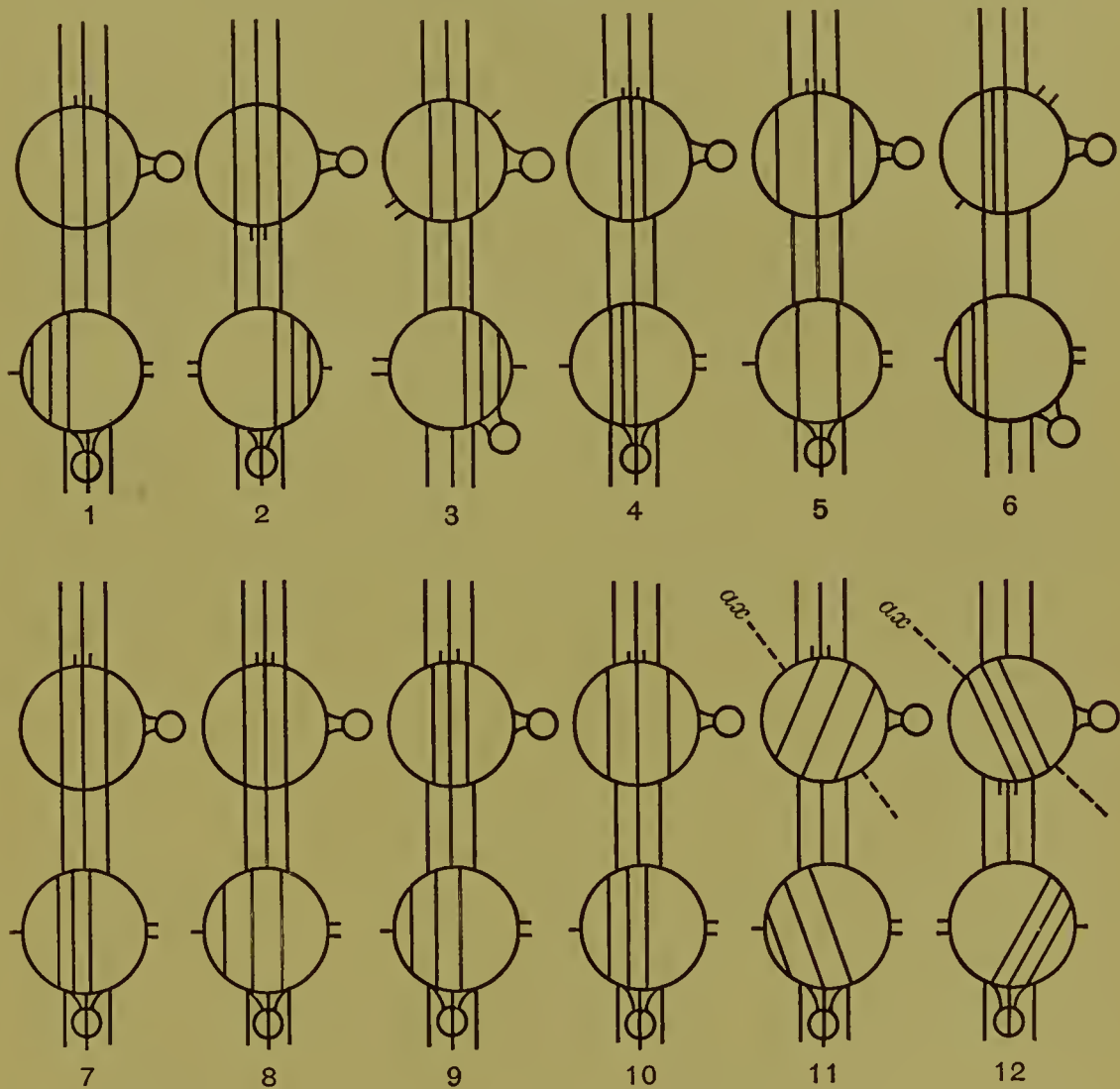
It often happens in practice that prismatic action is desired at right angles to the axis of the cylinder. In this case the results are simply added. If it is desired parallel to the axis, the cylinder may be ignored.

Though instruments of precision are sometimes used in the examination of spectacle lenses, the most common method is to judge of their strength by neutralizing or comparing them with the lenses of the test case or by noticing the distortions and displacements produced in some distant object by them. One ordinarily holds the lens to be tested so that its plane is perpendicular to the axis of vision, and looks through the geometrical centre at a straight line which is also perpendicular to the axis of vision and at the same time at such a distance from the anterior focus of the lens

that it can be made to form a reasonably clear image of itself on the retina. If the lens is spherical or a spherocylinder with the axis of the cylinder either parallel to or at right angles to the object line, this latter will apparently pass unbroken through the lens. It is thus that one determines the optical centre of a lens; and if it is identical with the geometrical centre, no prism has entered the combination either by construction or by decentring.

By having two object lines at right angles to each other, as in Dr.

FIG. 9.



Ziegler's scale, or in Fig. 14, below, one may at a glance determine the optical centre. If a spherical lens, held as above, be rotated about its optical centre in its own plane, the picture will not be changed; but if there be a cylinder in the combination, the peripheral parts of any line seen through it will be displaced in opposite directions. That point, however, which is seen through the optical centre of the lens will suffer no displacement, while that part which is seen through the geometrical centre will, by the direction and amount of its displacement, determine the prism which has thus entered into the combination.

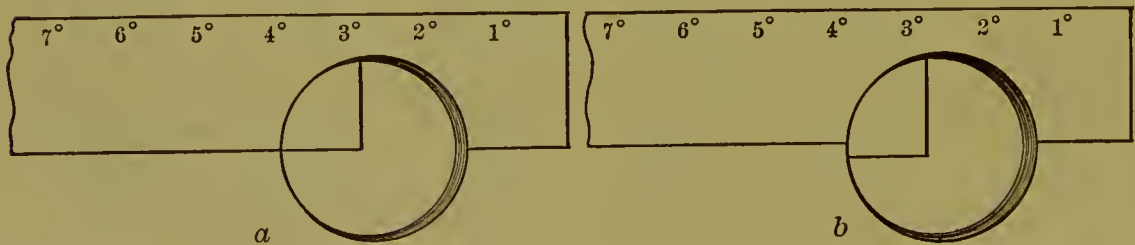
In cylinders or sphero-cylinders the observations and measurement of displacements must be confined to the one point seen through the geometrical centre of the lens, but in spherical lenses the maximum displacement of the line as a whole may be measured.

Three vertical lines looked at directly through a prismatic glass will present one of the pictures delineated in Fig. 9. Each number shows the same lens in two different positions, the base being marked by two short strokes, the apex by one. By rotating the lens in its own plane the upper picture may in each number be changed into the lower, and the picture seen as the lens rotates in its own plane through  $90^\circ$  is sufficient to determine the character, though not the strength, of the combination. Nos. 1, 2, and 3 are plane prisms; 4 and 6 are  $-$  sp.  $\odot$  Pr.; 5 =  $+$  sp.  $\odot$  Pr.; 7 =  $-$  Cyl.  $\odot$  Pr. base on axis; 8 =  $+$  Cyl.  $\odot$  Pr. base on axis; 9 =  $-$  Cyl.  $\odot$  Pr. base  $90^\circ$  from axis; 10 =  $+$  Cyl.  $\odot$  Pr. base  $90^\circ$  from axis; 11 =  $+$  Cyl.  $\odot$  Pr. base oblique to axis; 12 =  $-$  Cyl.  $\odot$  Pr. base oblique to axis. It will be observed also that only in convex glasses is the picture magnified, only in concave is it minified; and that as the glass rotates, only in plane prisms or sphero-prisms is there translation without rotation of the picture, and only in cylinders is there rotation of the picture; and in the first ten of these cuts the distance from the original place of the line to its apparent place when seen through the geometrical centre of the lens whose base-apex line is at right angles to it (divided in each case by the distance of the lens from the object line) is the tangent of the deviation. On this fact depends the utility of the prism scales by which most of our measurements are made.

In cases 11 and 12 the measurement must be made from the *point* seen through the geometrical centre of the lens to the line in its original position.

Fig. 10 *a* and *b* (from Maddox<sup>1</sup>) will show the method of use. The prism is held so that one sees, with minimum deviation, through it a

FIG. 10.



picture of the origin or 0 line of the scale, enough of the scale being visible with one or other eye to give with desirable accuracy the amount of the displacement as in *a*, *b* being an inaccurate attempt. The distance thus measured is the tangent of the deviation; but the lines of the scale may be so spaced and numbered as to determine the prism in units of any of the systems in use. Such a scale may be made from the following table for any of the previously mentioned systems, the distance from the prism to

<sup>1</sup> The Clinical Use of Prisms, Ernest Maddox, London, 1893.



the scale being one metre. For any other distance, larger or smaller, the numbers in the table are to be multiplied by the desired distance in metres. It seems hardly necessary to remind the reader that in the table given the third decimal place means millimetres, and the third column is a table of natural tangents.

TABLE II.

IN A WALL-TABLE FOR THE MEASUREMENT OF PRISMS THE DISTANCE OF EACH DIVISION FROM THE ORIGIN IS THE TANGENT OF THE DEVIATION PRODUCED BY THE PRISM WHOSE NUMBER IT MARKS. THESE TANGENTS ARE HERE GIVEN FOR THE DIFFERENT SYSTEMS INDICATED.

Number of Prism.	Refracting Angle System.	Deviation.	Centrad.	Prism-Diopter.	Metre-Angle.
1	.0094056	.0175	.0100034	.01	1 .0299
2	.01886	.0349	.0200035	.02	2 .0599
3	.028321	.0524	.0300045	.03	3 .0902
4	.035309	.0699	.0400194	.04	4 .1205
5	.04719	.0875	.0500407	.05	5 .1475
6	.05673	.1051	.060067	.06	
7	.06487	.1228	.070112	.07	
8	.07578	.1405	.080170	.08	
9	.08504	.1584	.090240	.09	
10	.09443	.1763	.100332	.10	
11	.10462	.1944	.110441	.11	1 .0320
12	.11452	.2126	.120575	.12	2 .0641
13	.12422	.2309	.130735	.13	3 .0966
14	.13402	.2493	.140926	.14	4 .1290
15	.14395	.2679	.151132	.15	5 .1620

} Interocular distance = .06.

} Interocular distance = .064.

The measurement of prismatic glasses at short distances by this method requires the use of finely ruled scales and mechanical devices for holding the prism. Such devices are embodied in Mr. Prentice's prismometer, an instrument which measures deviation at the position of perpendicular incidence on a radius of one-half metre or less. Prism scales, however, are usually made for longer distances than one metre, the advantage being that coarse scales are more easily constructed than fine ones, and that without sensible error one may bring the prism to the proper place by toeing a mark on the floor instead of adjusting it more carefully to a finer measurement.

There is little use in multiplying scales for office use. Take, for example, the one in Fig. 11. Within its limits one can measure centrad and prism-diopters with equal accuracy. To do this it is necessary to stand at five metres. To measure metric angles the left-hand numbers are to be used, and one must move seven centimetres towards the scale for every millimetre that the pupillary distance exceeds sixty, and ten centimetres away from the scale for every millimetre that it falls short of that number. To measure deviation in degrees it is necessary to hold the prism three-quarters of a metre farther back, and the scale reading is then to be divided by two. To measure refracting angles it is necessary to stand at 5.28

metres. In none of the above cases will the error be more than the width of the line. The usefulness of either of the other scales may be extended in the same way.

A caution is necessary in using these scales. With certain limitations, it may be said that their usefulness depends on the production of diplopia in the observer. As commonly used, this is a veritable binocular diplopia, and the displacement measured is the angular distance of the image seen by one eye from that seen by the other. A muscular insufficiency in the observer is quite likely to show itself as an error in the result. For that reason the vertical prism scale has a certain advantage over the horizontal, as being liable to a less average error. An error in either case, however, is inexcusable, for by moving and replacing the prism quickly before the eye while looking at the scale one obtains the result before the muscular trouble has time to injure the observation. In fact, by taking advantage of the long duration of the retinal image, one may in this way produce a unocular diplopia into which this error cannot enter.



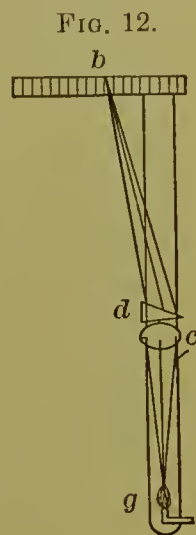
Perhaps there is no more satisfactory way of getting the prismatic power of a strong sphero-cylinder than by covering it, if necessary, with a diaphragm having an aperture of about five millimetres over the geometrical centre of the lens, and then producing in one eye, by its quick passage back and forth, the doubling of the scale.

All the strong lenses + or - 5 and over may be very accurately measured by the following method. To the origin of the scale a small reflecting surface of some brilliancy or a very small burning gas-jet is fixed. On the lens which is passed in front of the eye as above directed a pin or fine needle is so held that its point is at the geometrical centre. In the midst of the circle of diffusion caused by the point of light will be seen the image of the pin, and always at the same distance from the origin, which distance can be easily measured and is the deviation sought. One who wears glasses may

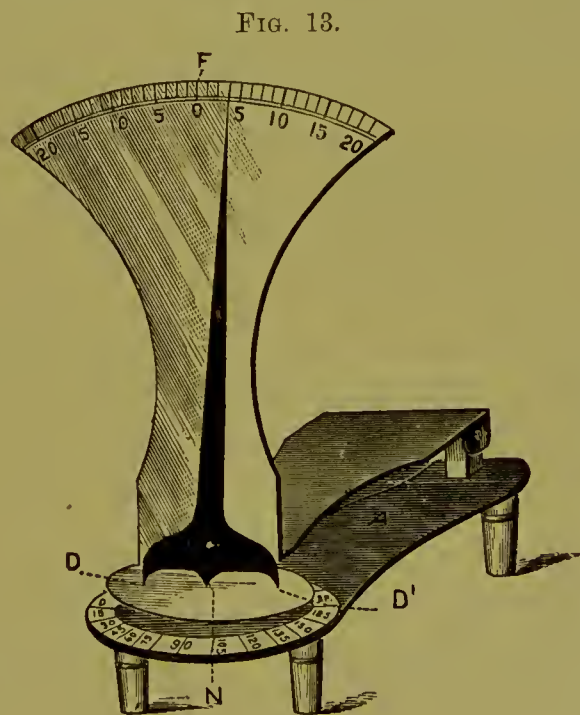
or may not vitiate this experiment by turning the head, and such an observer may do better to remove his glasses, for the success of this method requires that the lens being examined shall not correct the refraction of the examiner within three or four diopters. The pin-point may be replaced by an ink dot or by a strong lens having a diamond mark at its geometrical centre. With two such lenses—one plus and one minus—of five diopters or over to choose from, any spectacle lens may be thus examined.

Another method of getting the deviation is shown in Fig. 12, taken

from Maddox, where the image  $b$  of a small point of light  $g$  is thrown on the tangent scale or arc by a focussing lens  $c$ . The prism introduced at  $d$  displaces the image along this scale. The lens  $a$  should be replaced by a telescopic erecting piece, so arranged that the distance between its two lenses might be changed at will. It would then be equally suited for all sphero-prismatic combinations, the distance between the two lenses required for the formation of a distinct image indicating the number of the sphere, and the displacement denoting the number of the prism. The same principle can easily be extended to cylinders.

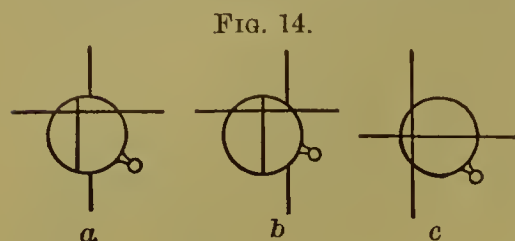


For measuring the refracting angle of a prism the Geneva Optical Company has introduced a cheap form of goniometer that does equally well for all lenses, either simple or compound. It gives, to be sure, only the refracting angle, but it is exceedingly convenient. The principle is shown in Fig. 13. The geometrical centre of the lens is placed under the point  $N$ . The extreme points  $D$  and  $D'$  are then pressed on the lens, which may be turned if necessary to give the maximum reading at  $F$ , the other end of the index hand.



Any object seen at the position of minimum deviation through a plane prism will be neither magnified, minified, nor distorted: it will be simply displaced. Translation of the prism in its own plane will produce no apparent motion in the object. Rotation of the prism in its own plane will change simply the direction, but not the amount of displacement; consequently, any point that can be identified will apparently rotate with the prism about its real position. A straight line whose elements cannot be distinguished the one from the other, however, will assume a simple har-

monie motion as the prism is turned, returning to its original position as often as the base-apex line of the prism becomes parallel to it. Its maximum displacement will be when it is at right angles to the base-apex line. Hence a picture like Fig. 14 determines at once the deviation and the base-

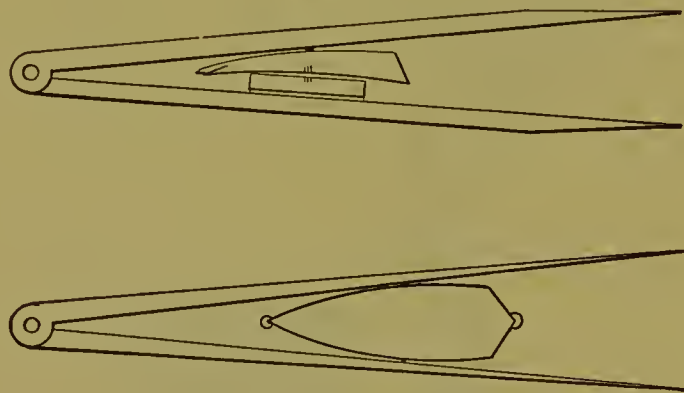


apex direction. By moving the prism to the left or right till the perpendicular line is unbroken, the optical centre of the lens, if such centre is situated in the glass itself, can be found at the intersection of the two lines.

In a plane prism the first thing to be determined is the base-apex line. It may be obtained by sight, as above, or, if the prism is so cut as to leave its edge intact, any line perpendicular to this may be taken as a base-apex line. In the prisms of the test cases that line passing through the geometrical centre is marked.

If it is desired to know the refracting angle, the index being known or assumed to be 1.54, it may be tested as previously noted on page 155; or it may be placed under the Geneva goniometer and revolved in its own plane until the maximum reading is obtained. It also may be placed between the legs of an ordinary pair of dividers, so that the legs fit closely along its two sides in the base-apex direction. (Fig. 15.) If the frame of the glass

FIG. 15.



interferes or the edge is cut too thin for such procedure, a small coin or a finger-ring of uniform section placed on one or both sides of the prism will obviate the difficulty. The degrees may be then read by placing the dividers on a protractor of radius that is equal to their length of leg. The spread of the dividers at the  $(\mu - 1)^{\text{th}}$  part of the distance from the hinge to the points will give the deviation for the same prism; if a weak one. It is easy from Formula (10) to mark on the dividers the place at which the deviation may be approximately measured for any refracting angle.

If the lens to be examined is a sphero-prism, the dividers are not as good a makeshift for the goniometer, though a double convex lens or a plano-convex pinched by them at its geometrical centre will show its refracting angle, and by the aid of the ring or a small well-centred coin the refracting angle can be nearly approached. The Geneva instrument, how-

ever, is more satisfactory; and this, in its turn, is not so accurate as the optical method, because the ultimate desire is usually the deviation, and that may be obtained more directly by the wall-scales, in accordance with the rules previously given on pages 153, 154, and 155. If there is a cylinder in the combination, it is best to rely on the optical methods or to employ the Geneva instrument.

It is very often convenient to know with considerable exactness the relation that exists between decentring and prismatic action. For this purpose the table on page 160, taken from Maddox, will be found useful.

Without a table, the relations are easily obtained from the properties of the lens. Parallel rays entering the lens all cross each other at the focal plane, only the central ray being unchanged in direction. Hence any ray passing through the plane of the lens will make an angle with the central ray which is equal to the deviation that is produced by the lens at that point,—an angle whose tangent is the decentring of the lens, the focal distance being the radius. Hence, if  $D$  equal the strength of the lens in diopters,  $y$  the amount of the decentring,  $f$  the focal distance (equal, of course, to  $\frac{1}{D}$ ), and  $d$  the deviation, we have

$$\frac{y}{f} = \tan d, \text{ or } Dy = \tan d. \quad (18)$$

Multiplying both sides of the equation by 100 to reduce to prism-diopters,

$$100 Dy = d^\Delta. \quad (19)$$

For centrad, use the same formula,

$$100 Dy = d^\nabla, \quad (20)$$

but measure the decentring  $y$  on the curved surface (supposed double convex), or, rather, imagine it measured there; the difference is usually imperceptible. For degrees, reduce by the coefficient .57295,

$$57. Dy = d^\circ. \quad (21)$$

For metric angles, divide by 3,

$$19. Dy = d^m. \quad (22)$$

These formulæ are useful as answers to questions of this type: What will be the deviation in metre-angles caused by decentring a seven-diopter lens six millimetres? In the metric system six millimetres is .006, and Formula (22) solves the question, thus:

$$19 \times 7 \times .006 = d^m = .798,$$

which is nearly eight-tenths of a metre-angle.

In a question like this, How far shall a four-diopter lens be decentred to give a deviation of three prism-diopters? we have from (19)

$$y \frac{d}{100D} = \frac{3}{400} = .0075,$$

which gives the answer, 7.5 millimetres.

TABLE III.

D.	1 mm.	2 mm.	3 mm.	4 mm.	5 mm.	6 mm.	7 mm.	8 mm.	9 mm.	10 mm.	11 mm.	12 mm.	13 mm.	14 mm.	15 mm.	16 mm.	18 mm.	20 mm.	22 mm.	24 mm.	26 mm.	28 mm.	30 mm.	32 mm.
.5	1' 43"	3' 26"	5'	7'	8' 25"	10'	12'	14'	15' 28"	17'	19'	20' 37"	22' 27"	24'	26'	27' 30"	31'	35'	38'	41'	45'	48'	52'	55'
.75	2' 30"	5'	8'	10'	13'	15' 28"	18'	20' 37"	23'	26'	28'	31'	33'	36'	38'	41'	46'	52'	57'	1° 2'	1° 6'	1° 12'	1° 17'	1° 22'
1	3' 26"	7'	10'	14'	17'	20' 37"	24'	27' 30"	31'	35'	38'	41'	45'	48'	52'	55'	1° 2'	1° 9'	1° 16'	1° 23'	1° 30'	1° 36'	1° 43'	1° 50'
1.5	5'	10'	15' 28"	20' 37"	26'	31'	36'	41'	46'	52'	57'	1° 2'	1° 6'	1° 12'	1° 17'	1° 22'	1° 32'	1° 43'	1° 53'	2° 3'	2° 13'	2° 24'	2° 34'	2° 44'
2	7'	14'	20' 37"	27' 30"	35'	41'	48'	55'	1° 2'	1° 9'	1° 16'	1° 23'	1° 29'	1° 36'	1° 43'	1° 50'	2° 4'	2° 18'	2° 32'	2° 46'	2° 58'	3° 12'	3° 26'	3° 40'
3	10'	15' 28"	21' 41"	27' 30"	35'	41'	48'	55'	1° 2'	1° 9'	1° 16'	1° 23'	1° 29'	1° 36'	1° 43'	1° 50'	3° 6'	3° 26'	3° 46'	4° 7'	4° 27'	4° 48'	5° 9'	5° 29'
4	14'	27' 30"	41'	55'	1° 10'	1° 22'	1° 36'	1° 50'	2° 4'	2° 18'	2° 32'	2° 46'	2° 58'	3° 12'	3° 26'	3° 40'	4° 8'	4° 35'	5° 2'	5° 29'	5° 56'	6° 24'	6° 50'	7° 18'
5	17'	35'	52'	1° 9'	1° 26'	1° 43'	2°	2° 18'	2° 35'	2° 52'	3° 9'	3° 26'	3° 43'	4° 1'	4° 17'	4° 35'	5° 9'	5° 44'	6° 17'	6° 51'	7° 24'	7° 58'	8° 32'	9° 6'
6	20' 37"	41'	1° 2'	1° 23'	1° 43'	2° 4'	2° 24'	2° 45'	3° 5'	3° 26'	3° 46'	4° 7'	4° 27'	4° 48'	5° 9'	5° 29'	6° 10'	6° 51'	7° 31'	8° 12'	8° 52'	9° 32'	10° 12'	10° 52'
7	24'	48'	1° 12'	1° 36'	2°	2° 24'	2° 48'	3° 12'	3° 37'	4° 1'	4° 24'	4° 48'	5° 12'	5° 36'	6°	6° 24'	7° 11'	7° 58'	8° 45'	9° 32'	10° 19'	11° 5'	11° 52'	12° 38'
8	28'	56'	1° 22'	1° 50'	2° 18'	2° 46'	3° 12'	3° 40'	4° 8'	4° 35'	5° 2'	5° 29'	5° 56'	6° 24'	6° 50'	7° 18'	8° 12'	9° 6'	9° 59'	10° 52'	11° 45'	12° 38'	13° 30'	14° 22'
9	31'	1° 2'	1° 32'	2° 4'	2° 35'	3° 6'	3° 37'	4° 8'	4° 38'	5° 9'	5° 39'	6° 10'	6° 40'	7° 11'	7° 41'	8° 12'	9° 12'	10° 1'	11° 12'	12° 11'	13° 10'	14° 9'	15° 7'	16° 4'
10	35'	1° 9'	1° 43'	2° 18'	2° 52'	3° 26'	4° 1'	4° 35'	5° 9'	5° 44'	6° 17'	6° 51'	7° 24'	7° 58'	8° 32'	9° 6'	10° 12'	11° 19'	12° 25'	13° 30'	14° 34'	15° 39'	16° 42'	17° 45'
12	41'	1° 23'	2° 4'	2° 45'	3° 26'	4° 7'	4° 48'	5° 29'	6° 10'	6° 51'	7° 31'	8° 12'	8° 52'	9° 32'	10° 12'	10° 52'	12° 11'	13° 30'	14° 47'	15° 39'	16° 42'	17° 45'	18° 48'	19° 48'
14	48'	1° 36'	2° 24'	3° 12'	4° 1'	4° 48'	5° 36'	6° 24'	7° 11'	7° 58'	8° 45'	9° 32'	10° 19'	11° 5'	11° 52'	12° 38'	14° 9'	15° 39'	17° 7'	18° 34'	19° 48'	20° 47'	21° 47'	22° 47'
16	56'	1° 50'	2° 46'	3° 40'	4° 35'	5° 29'	6° 23'	7° 19'	8° 12'	9° 6'	9° 59'	10° 52'	11° 45'	12° 38'	13° 30'	14° 22'	16° 4'	17° 45'	19° 24'	21'	22° 7'	23° 8'	25° 38'	27° 7'
18	1° 2'	2° 4'	3° 6'	4° 8'	5° 9'	6° 10'	7° 11'	8° 12'	9° 12'	10° 12'	11° 12'	12° 11'	13° 10'	14° 9'	15° 7'	16° 4'	17° 57'	19° 48'	21° 36'	23° 22'	25° 5'	26° 45'	28° 22'	29° 57'
20	1° 9'	2° 18'	3° 26'	4° 35'	5° 44'	6° 51'	7° 58'	9° 6'	10° 12'	11° 19'	12° 25'	13° 30'	14° 34'	15° 39'	16° 42'	17° 45'	19° 48'	21° 48'	23° 45'	25° 38'	27° 29'	29° 15'	30° 58'	32° 37'

Table showing the prismatic effect of decentering any lens made from the formula  $\tan x = \frac{d}{f}$ ;  $x$  being the deviating angle of the virtual prism,  $d$  the decentering in millimetres,  $f$  the focal length of the lens. (From Maddox.)

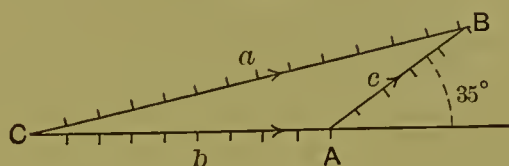
It is sometimes necessary to know the result of combining two prisms of different strength, so placed that the base-apex lines are not parallel. The general problem is one of spherical trigonometry, where each side of the triangle is an arc which is equal in degrees to the deviation, and where one of the angles—that between two of the prisms—is given. The formula is

$$\cos a = \cos b \cdot \cos c - \sin b \cdot \sin c \cdot \cos A, \quad (23)$$

in which, of course, small letters are sides and large letters are angles.

The following example will illustrate and Fig. 16 will show the vector, the graphic, and the trigonometrical method. What is the result of putting

FIG. 16.



before the eye two prisms,  $b$  and  $c$ , the apex of one being at  $0^\circ$ , the other at  $35^\circ$ , on the trial frame,  $b$  being equal to  $9^d$ ,  $c$  equal to  $5^d$ , and  $a$  equal to the resultant prism?

$$\cos a = .9877 \times .9962 - .1564 \times .0871 \times .8192 = .97274.$$

.97274 is the cosine of  $13^\circ 24'$ , the required prism. The same formula may be transposed and applied to the finding of the angle  $C$ , when the whole problem is determined.

It is rarely necessary to use a rigidly accurate formula. The customary method is to consider the question one of simple trigonometry on the tangent plane, using the formula for the solution of oblique triangles, and changing the sign of the cosine as before, this being done because the angle between the two prisms becomes the external angle in the triangle to be solved. The formula in this case is

$$a^2 = b^2 + c^2 - 2bc \cos A. \quad (24)$$

When the angle  $A$  between the two prisms is a right angle, the last term in the equation becomes 0, and the problem is reduced graphically to the Pythagorean proposition that the resultant prism is the square root of the sum of the squares of the other two prisms. The strength of the prisms being given, either of the angles can be found by the formula

$$\cos B = \frac{a^2}{2ac} + \frac{b^2}{2ac} - \frac{c^2}{2ac}; \quad (25)$$

or, when  $A$  is a right angle,

$$\tan B = \frac{c}{b}. \quad (26)$$

The above results are obtained for the superposition of two prisms before

one eye. If one of the prisms is placed before the other eye, the sign of the last term of equation (24) is to be changed from  $-$  to  $+$ , and the last term of equation (25) from  $+$  to  $-$ ; or, what amounts to the same thing,  $180^\circ$  is to be added to the position of the prism in the trial frame, and the above formulæ used as they stand.

It is sometimes desirable to produce a displacement of variable degree, but in one direction only, by prismatic action. In most cases this is accomplished by the rotation of one or more prisms, each in its own plane.<sup>1</sup> When a prism with its plane perpendicular to the axis of vision is rotated in that plane and about the visual axis, any object seen through it moves in a circle about its real position. The displacement is always equal in amount, but is variable in direction. The well-known device of considering circular motion as composed of two simple harmonic motions at right angles to each other is particularly useful here, since the principal motions of the eye are made by two pairs of muscles whose lines of action are also at right angles to each other.

The resolution of the circular motion into its vertical and horizontal harmonic components enables us to show at a glance, or calculate with precision, just how much of the displacement caused by a prism in any position is corrected by the horizontal, and how much by the vertical, muscles. The deviation or displacement being always towards the apex, to obtain the component for any other direction the total amount is to be multiplied by the cosine of its angular distance from the apex. As an illustration, let it be asked, What part is played by each of the four recti muscles in adjusting the right eye to a prism of  $8^d$ , whose apex is, as placed in the trial frame, at  $85^\circ 30'$ , the degree marks on the frame being numbered counter-clockwise from the insertion of the internal rectus? Below is given the result of multiplying the cosine of the angular distance of the insertion of each muscle from the prism's apex by the number of the prism:

$$\begin{aligned} \text{Internal rectus, } & - 85^\circ 30' + .25 \times 8 = 2^d. \\ \text{Superior rectus, } & + 14^\circ 30' + .968 \times 8 = 7.75^d. \\ \text{External rectus, } & + 104^\circ 30' - .25 \times 8 = - 2^d. \\ \text{Inferior rectus, } & + 194^\circ 30' - .968 \times 8 = - 7.75^d. \end{aligned}$$

The minus sign in the first column indicates that the position of the internal rectus was measured by counting the degrees backward on the scale. Minus in the last column indicates an adjustment by relaxation.

The distribution of work among the muscles may also be estimated by multiplying the strength of the prism by the sine of the number of degrees through which the apex of the prism is removed from the "position of no effect," the positive direction being that in which it will reach the muscle the most quickly. Thus, when the apex is vertical, the prism has no effect on the right internal rectus, because, as the apex is turned clockwise, the sine

<sup>1</sup> For convenience of construction, the prism is sometimes rotated in the plane of one of its faces, the resulting difference being unimportant.



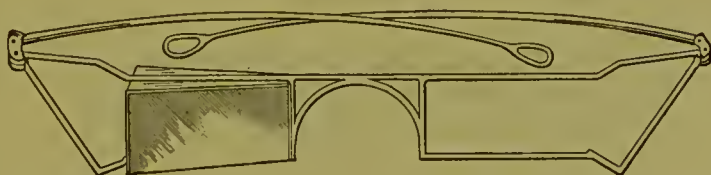
of the angle through which it has turned is the fractional part of the deviation which must be corrected by the internal rectus. Consequently, if the prism is numbered in units of deviation, it is convenient to assume that the initial departure from the "position of no effect" produces one minute of deviation per unit of prism for every degree of rotation. After about thirty degrees have been reached the rigid formula must be used.

The compounding of two circular motions of equal period, amplitude, and epoch, but of opposite sense, produces a simple harmonic motion of double the amplitude, and so the deviation for any position produced by two prisms which are turned equally in opposite directions may be thus found. It will be in a line which bisects internally the base-apex lines of the component prisms, and in amount will be a prism which is equal to their sum multiplied by the sine of the angle through which either one has turned from the "position of no effect."

Familiarity with the principles thus far considered will make it an easy matter to understand and apply prisms and prism-carrying instruments to the purposes for which they are designed. It only remains to mention the forms in which they are generally seen. Most familiar are the ten prisms from  $2^\circ$  to  $20^\circ$  that are furnished with the Nacet case of lenses. These fit the trial frames and have the base-apex line marked. By a little care and management they will do almost everything that is required in ordinary clinical work. Nearly all the required amounts of deviation may be produced by interchange and superposition before one or both eyes.

Any pair of muscles may be eliminated from the experiment by using a line of uniform width in the plane of the muscles for an object. Equal prisms homonymously or symmetrically placed one before each eye and rotated by the fingers will be found a very good makeshift for some of the more elegant arrangements. This is said without any desire to cheapen the better instruments or to discourage the use, under all circumstances, of the best obtainable.

FIG. 17.



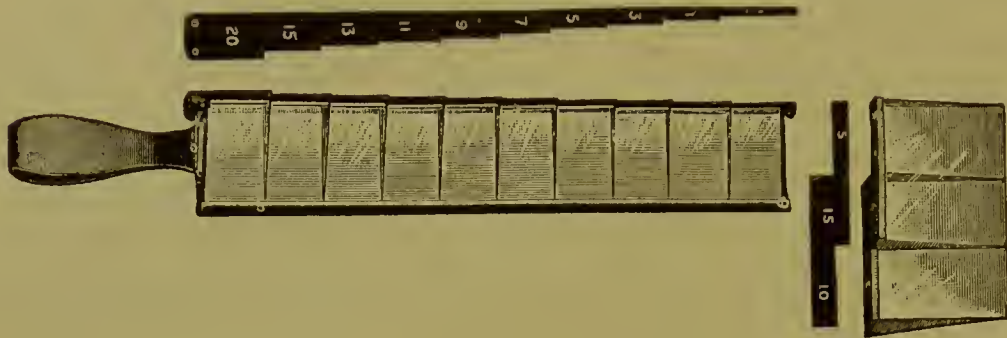
For producing definite amounts of heterophoria, prisms can be permanently mounted in special trial frames, with or without a spirit-level attached, or can be made in sets to fit such frames as shown in Fig. 17, from Maddox.

This is not the place to consider the advantage of intermittent over-continuous increase of deviating power in the examination of muscular troubles. It is quite likely that neither plan should entirely supplant the other, and the next instrument in order of simplicity is Dr. Noyes's<sup>1</sup> bar

<sup>1</sup> Text-Book of Diseases of the Eye, Henry D. Noyes, New York, 1890.

arrangement of rhomb-shaped prisms (Fig. 18) advancing by intervals of  $2^\circ$ , with a supplementary bar containing prisms of  $5^\circ$ ,  $15^\circ$ , and  $10^\circ$ , to be held in front of the longer bar if necessary. Dr. Emerson has modified this device by fixing one or more supplementary prisms so that they may

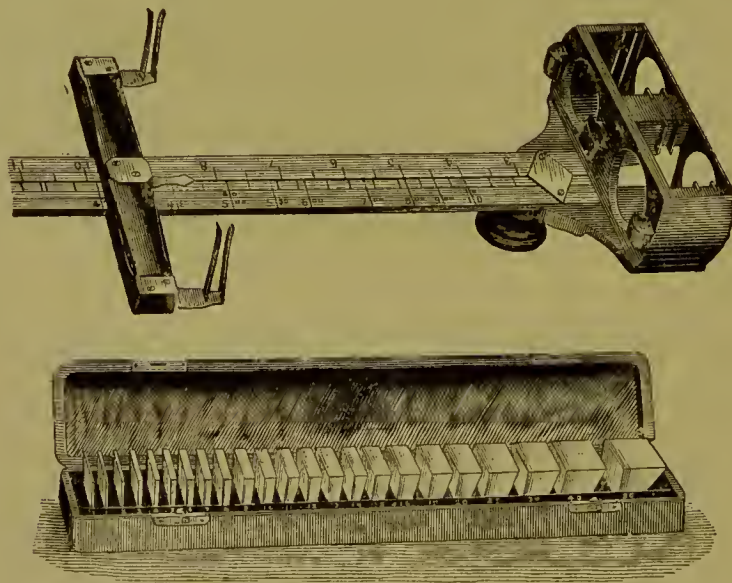
FIG. 18.



be slid along the back of the long bar to the place needed. Dr. Noyes has also introduced a very convenient form of stereoscope to be used with a set of square prisms. Any useful deviation can be produced by this device, either for near, for virtual, or for actual distance, components and resultants being calculated if necessary.

The Herschel combinations for continuous increase of deviation in a single and definite direction are all analogous in action and construction

FIG. 19.



to the Stokes lens. The first to be introduced to the clinical ophthalmologist was the Creté "prisme mobile." In this contrivance two equal prisms are moved in opposite directions by a button that slides along the handle at a rate which is proportional to the angular motion of the prisms. Mounted in various ways and moved by various gears, this combination was modified without material improvement until it was made by Dr. Risler to fit the trial frame. (See Fig. 20.) This arrangement has been

still further modified by Dr. Jackson, by the addition of a third prism of like strength, but immovable, it being so placed that it entirely neutralizes the Herschel combination when that combination is in the position of maximum effect. The object of this addition is to reverse the irrationality

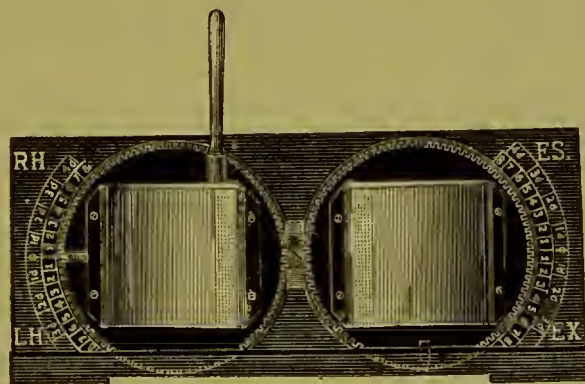
FIG. 20.



of the scale, so that the finer gradations may be easily noted at the first part,—*i.e.*, for the weaker numbers.

A radical improvement for some purposes has been made over the Herschel combination by Dr. Stevens's phorometer (Fig. 21), which trans-

FIG. 21.



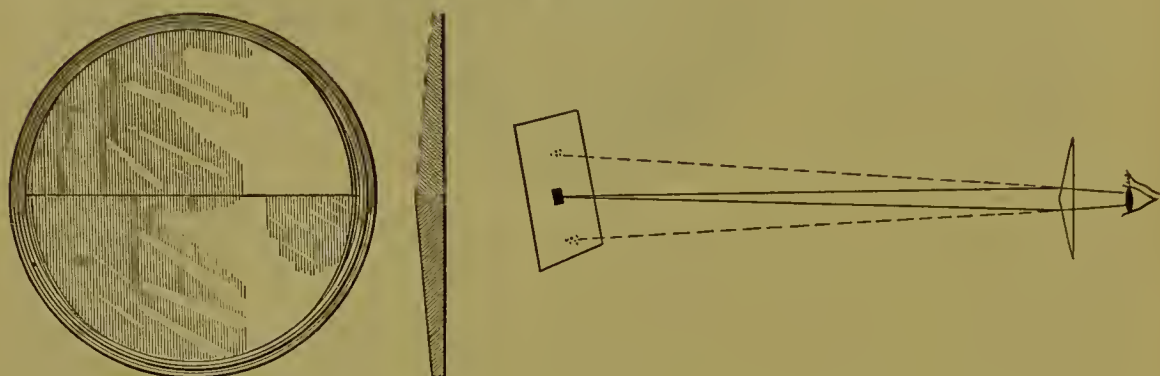
fers one of the prisms to the other eye, thus dividing the effect between the two eyes. It need only be referred to here, as the instrument is described by him in another article in the System. From a physical standpoint, the difference is that the two images are equally displaced, and revolve about the fixation point of the "œil cyclopienne" at opposite ends of the diameter that passes through it. The lenses are so large, also, that they may be operated at a considerable distance from the patient's eye, thus adding to the convenience of both the patient and the examiner. The formula by which the results are calculated is the same as for the Herschel combination, except that it is necessary to add  $180^\circ$  to the trial frame position of the prism which is transferred from one eye to the other.

Every one is familiar with the "Maddox double prism" (Fig. 22), which is a prism of  $175^\circ$ , so worn that the apex bisects the pupil and thus

produces unioocular diplopia, the two objects thus seen determining the line of equilibrium for the other eye. The apex should be perfectly ground.

The Wollaston prism in the Javal ophthalmometer consists of two quartz prisms, so cut that when in position the base of each is at the apex of the other, and the optical axis of each is at right angles to that of the other and to the axis of vision. By this arrangement the two waves that are ordinary and extraordinary in the first prism become respectively extraordinary and ordinary in the second. The result is that the second prism is rarer for one wave and denser for the other than the first, and the refraction takes place

FIG. 22.



in equal amounts, but in opposite directions. The deviation thus obtained is for each ray the same as if it had passed at perpendicular incidence through a prism of like number of degrees, but of a refractive index equal in the one case to the ordinary divided by the extraordinary index of quartz, and in the other case to its reciprocal. These numbers as obtained from Everett are for one wave 1.00689, for the other .99414.

The refracting angle  $R$  of either of these equal prisms thus becomes the angle of incidence for either ray in its passage from one to the other. The deviation may be calculated for either, as the amounts are equal, the directions being opposite. That for the ordinary ray is thus obtained :

$$D_1 = \sin^{-1} (1.00689 \times \sin R) - R.$$

$D_1$  then becomes the angle of incidence on the last surface of quartz, and its further increase may be calculated by using the mean index of quartz for air, which is 1.54874 :

$$\sin^{-1} (1.54874 \times \sin D_1) = D_2.$$

$D_2$  is the total deviation produced in one ray. Doubling this final result gives  $2D_2$ , the angular separation of images seen through a Wollaston prism. The following simple formula connects  $D_2$  with  $R$  :

$$\sin D_2 = (\mu_o - \mu_e) \tan R.$$

# THE PRINCIPLES OF AND THE METHODS FOR THE ESTIMATION OF THE BAL- ANCE OF THE EXTRA-OCULAR MUSCLES.

BY GEORGE T. STEVENS, M.D., PH.D.,  
New York City, New York, U.S.A.

---

IN the determination of the relative positions of objects in the field of regard by the sense of sight, the relation of the points of the retina on which the impression of the object is received to the macula lutea, or the sense of the muscular adjustment demanded in order to bring the impression to the macula, constitutes the basis on which is formed the judgment in regard to the positions and the expanse of the objects seen.

If the normal eye is so directed as to receive the most distinct perception of a given object or portion of an object, the eye must be so adjusted that a straight line drawn from the point of regard will pass through the nodal point of the eye to the macula or fovea centralis retinæ.

The extent of an object in the field of vision or the distance or direction of any other object with reference to the first in any other part of the plane of the field of vision is determined by reference to the relative distance and position of a second retinal impression from this given point or by the estimation of the muscular sensations which arise or which would arise from changing the adjustment from the first point of regard to the second.

The straight line drawn from the point of regard through the nodal point to the macula is known as the visual line, which nearly, although not precisely, corresponds with the axis of the eye. The angle made by the intersection of the visual line and of the axis of the eye is known as the angle  $\alpha$ .

If the rays of light from an object are concentrated at any one point of the retina, the object is seen singly with that eye; but if the rays are so divided as to fall upon more than one point, an image of the same object may be recognized as having the appearance of more than one object.

When two images of the same object are seen by the same eye the phenomenon is known as monocular diplopia. In eyes not abnormally affected or not very irregular in refractive character monocular diplopia can be induced only by artificial means, but in certain diseased conditions of the media in which dispersion of the rays of light results, and in certain

refractive anomalies, multiple images may be the cause of much annoyance. Monocular diplopia sometimes also follows a surgically induced change in the relative adjustments of the two eyes.

It is, for experimental purposes, easy to induce the second image in a single eye by artificial means. If one holds a prism or a convex spherical lens before the eye in such a manner that the edge intercepts a part of the rays from the object which enter through the pupil while other rays from the object pass directly through the pupil, the prism or spherical lens will divert the rays passing through it so that an impression of the image will be made on the retina at a point removed from the impression made by the rays passing directly, and the object will be attributed to two positions; that is, monocular diplopia will be induced.

In the adjoining figure (Fig. 1) the edge of the prism is brought from below so as to be at the height of the centre of the pupil. The rays of light which pass through the upper portion of the pupil from *A* pass

FIG. 1.

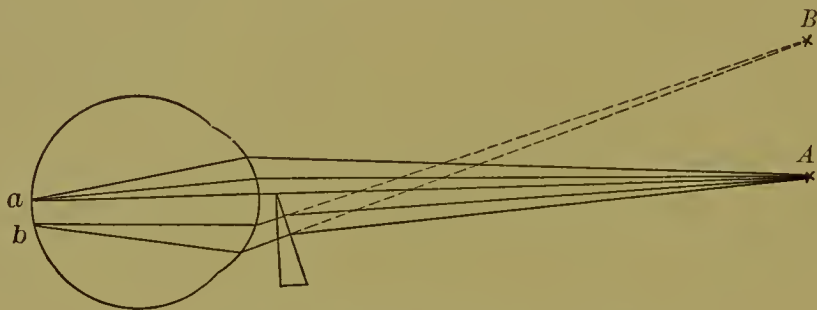


Diagram illustrating monocular diplopia.

directly, with the usual refraction, to the macula at *a*, while those which enter the lower half of the pupil have been directed downward in their course, and the impression is made at *b*. The object as perceived at the point *a* will appear at *A*, while the same object as perceived at *b*, the lower point in the retina, will appear above the first image at *B*.

From this experiment with a single eye it will be easy to understand that if the images which are represented upon the two retinae are not represented upon corresponding points of these retinae, the object will appear to the two eyes as being seen in two places. For example, if, the head being in the primary position, in one eye the image is formed at the macula or point *a*, as in the figure, and in the other eye it is formed at a point corresponding to *b*, then the apparent position of the images will be exactly in the same relation as when they were seen by one eye at *A* and *B*, and therefore there will be double vision resulting from the two eyes, or binocular diplopia.

In the normal arrangement of the eyes there is always an effort, by means of muscular adjustments of the axes of the two eyes, to bring them into such relations that the image of the "point of regard" will fall upon exactly corresponding parts of the two retinae. When this adjustment is

accomplished the two eyes see as one and a single perception is presented to the mind. Although the two eyes in ordinary vision act as one, they are by no means restricted to a single sensation. The impressions may be made at points of the retinae which are not at all identical in the two eyes, but in order to convey the impression of single vision they must be corresponding points.

The manner in which the impressions are made upon corresponding points is illustrated in Fig. 2.

If the point *A* makes impressions at the points *a, a* of the two retinae, and if *B* makes impressions at *b, b*, then *a* and *a* are corresponding points and *b* and *b* are corresponding points.

The visual angle is that angle which is formed at the nodal point by the crossing of lines drawn from different points in the "field of regard,"—that is, from different points of an object or from different objects. The

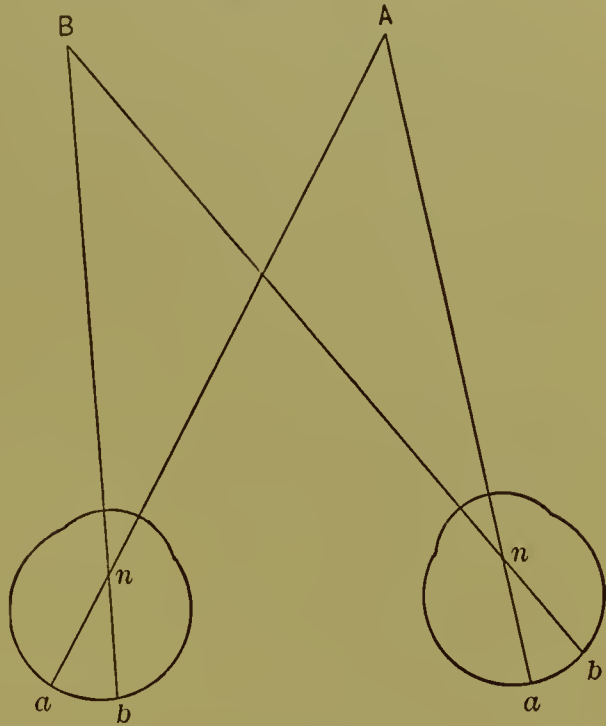
spatial points of the retina affected by the extension of these lines backward (Fig. 3) convey to the mind by their relative positions the idea of the relative positions of these different points of regard.

This mental achievement is in reality an interpretation, either before the act or the result of it, of sensations excited by the muscular effort which is, or which would be, required to move the eye so that the point *a'* should be brought to occupy the position of the point *A'*.

When we consider the minute distances between the retinal spaces which are to be measured by muscular sensation, and when we further consider the fact that this wonderfully accurate estimation

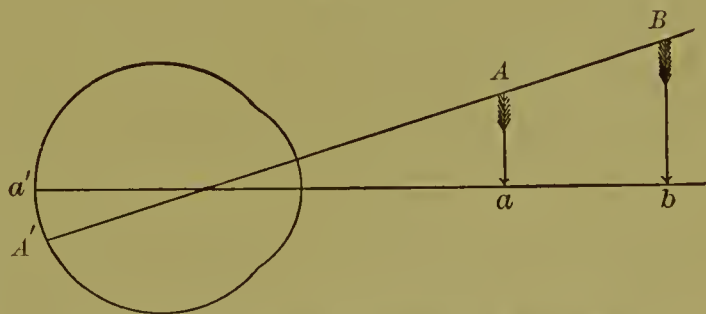
of muscular energy must be directed to the two eyes in infinitely varying positions, the marvellous delicacy of the sense of the small ribbon muscles which move the eyes becomes a subject of great practical importance. It

FIG. 2.



Corresponding points.

FIG. 3.



The visual angle.—The extremities of the object *Aa*, at the distance *A*, are projected on the retina at *A'a'*, while the extremities of the larger object *Bb*, at the distance *B*, by forming the same angle at the nodal point, are projected at points of the retina equally separated with those of *Aa*.

is apparent that if at every instant of the constantly changing adjustments of the eyes during all the hours of wakefulness this unity of adjustment and this perfect judgment of energy are unceasingly exercised, it cannot require a gross malassociation of these most accurate of all muscles to cause disturbance. As a matter of fact, very slight faults of relative tensions may result in extremely important disturbances of nervous energy when the adjustments demanded are minute and continuous.<sup>1</sup>

The associated movements of the two eyes, achieved by the combined action of the various eye-muscles, imply a nicety of balance and a quick response to nervous impulse not found in other parts of the organism.

It is impossible to form an estimate of the force which under the influence of the will may be exercised in bringing about the adjustments required of the two eyes.

By reason of a less favorable arrangement of the muscles one person may be obliged to exercise greater force under the direction of the will than another person in whom the arrangements are more favorable, and the disadvantageous construction in the case of the first does not by any means imply weakness of any muscle or pair of muscles. Indeed, in many, if not in most, cases of the conditions which have often been styled "weakness" of certain muscles, all the muscles within the orbit are strong, often much stronger than they would be in a condition of perfect equilibrium. Especially is this true of muscles to which the expression "weak" is most commonly applied. This statement can be easily verified by the tropometer.

Reactions through the medium of the nervous centres resulting from anomalies in the moving apparatus of the eyes may be of greater or less account, and may assume a variety of forms, depending upon the physical force at the command of the individual, his environments, and the circumstances to which he may be subjected. And it happens that an anomalous condition of the eye-muscles which may induce little apparent nervous reaction in one person may be the cause of important disturbances in another.

In all examinations relating to the equilibrium of the eye-muscles the fact that the element of voluntary effort on the part of the person examined can rarely be eliminated is not to be underrated.

We cannot measure the comparative difference of effort in all ocular adjustments in different individuals directly. We may, however, take advantage of the double images which may exist, or which may be artificially induced, to make an approximate estimate of the extent and character of the hinderances to perfectly free associated movements.

As a result of such an examination, we may find either that there is an apparently correct muscular arrangement or that certain muscular disabilities exist.

---

<sup>1</sup> Stevens, Light in its Relation to Disease, New York Medical Journal, June, 1877.



In the cases in which there is apparently the best muscular equilibrium—that is, the condition in which parallelism of the visual lines is maintained with the minimum of nervous effort—the condition is known as *Orthophoria*.

The disabilities of less favorable muscular conditions may be arranged in three classes.

In the first there exists the power to bring the two eyes into such relative positions that single vision is habitually maintained; but the tendency is for the visual lines not to fall upon the same point of regard, and it is through an effort of the will, conscious or unconscious, that they do not follow the tendency and thereby induce double vision.

The conditions of tendencies unfavorable to adjustments of the two eyes in perfect accord, but which tendencies are successfully resisted, are known under the general term of *Heterophoria*.

In cases in which the disability is still greater and the visual lines are actually not directed to the same point of regard, there is habitual diplopia, which, however, is not always conscious diplopia. Such cases in which the visual lines do not fall upon the same point of regard are included under the general term of *Heterotropia* or *Strabismus*.

The various conditions of equilibrium or variation from it may, then, be arranged in the four general classes:<sup>1</sup>

1. *Orthophoria* (*ὀρθός*, right; *φορά*, a tending), a tending of the visual lines in parallelism.

2. *Heterophoria* (*ἕτερος*, different), a tending of the visual lines in some other direction, but with ability to adjust them habitually for single vision.

3. *Heterotropia* (*τροπός*, a turning), a deviation of the visual lines from parallelism in such manner that they cannot habitually be united at the same point of fixation.

4. *Anotropia*, *Katotropia*; or *Anophoria*, *Katophoria*. Variations from equilibrium which may or may not be consistent with parallelism of the visual lines, but in which with the least innervation of the eye-muscles the visual lines of both eyes would fall below (*katotropia*) or rise above (*anotropia*) the most favorable plane for the minimum effort. Thus with *ano-* or *katotropia* there may be associated *heterophoria* or *heterotropia*.

**Class I.**—*Orthophoria*, or the condition of equilibrium, recognizing in this connection the question of *anotropia* or *katotropia*, is, then, the ideal form of adjustment, and is subject to no divisions.

**Class II.**—The second group of conditions, *heterophoria*, may be divided into the following specific conditions:

1. *Esophoria*, a tending of the visual lines inward.

---

<sup>1</sup> Stevens, *Archives d'Ophthalmologie*, November, 1886; *New York Medical Journal*, December 4, 1886.

2. *Exophoria*, a tending of the visual lines outward.
3. *Hyperphoria* (right or left), a tending of the visual line of one eye (right or left) in a direction above its fellow, constituting, as the case may be, *right* or *left* hyperphoria.

The term does not imply that the line to which it is referred is too high, but that it tends higher than the other, without indicating which may be at fault.<sup>1</sup>

The compound tendencies are—

1. *Hyperesophoria* (right or left), a tendency of one visual line above the other, with a tendency also of the lines inward.
2. *Hyperexophoria* (right or left), a tendency for one visual line to rise above the other, with a tendency also outward.

**Class III.**—The class *Heterotropia*, in which, when the visual line of one eye is fixed upon a given point within the ordinary field of regard, that of the other is directed to some other point, may be divided into two sub-classes. They are—

(a) Deviations consistent with a physiological state of the muscles and nerves, as in the ordinary concomitant squint.

(b) Deviations resulting from pathological conditions, as, for example, deviations from paralysis or from mechanical causes.

The specific divisions of the sub-class *a* are—

1. *Esotropia*, a deviation of the visual lines inward.
2. *Exotropia*, a deviation of the visual lines outward.
3. *Hypertropia* (right or left), a deviation of one visual line above the other.
4. *Hyperesotropia* and *Hyperexotropia* are the compound deviations.

These are the conditions usually found in concomitant squint. A large proportion of the subjects of heterotropia are unconscious of seeing double, for, while the physical phenomenon of diplopia exists, there is a mental suppression of the consciousness of the anomaly.

In heterotropia one eye is, in a large proportion of cases, selected by the subject of the defect for habitual fixation, while the other is permitted to deviate. This choice is usually made with regard to the comparative fitness of the eyes for easy vision, or with reference to the comparative ease of adjustment with respect to the depression of the angle of regard. For example, if one eye is nearly emmetropic while the other is highly astigmatic, the emmetropic eye is commonly used in fixation. Also if the visual line of one eye deviates considerably above the other, it is commonly more difficult to adjust the eye whose visual line is highest to objects below the horizontal plane, and consequently this eye is the one often permitted to deviate, and it frequently turns not only up, but in or out.

---

<sup>1</sup> Hence there can be no possible reason for the introduction in this relation of any other term to show that one is lower than the other.

For somewhat similar reasons alternating strabismus occurs; but in this case the refractive conditions are usually less unequal, and the muscular tensions, although unfavorable, are more uniform.

In heterotropia of the sub-class *a* the various motor muscles are supposed to be in a physiological condition, or nearly so, although in old and extreme cases some of the muscles of the habitually deviating eye lose their physiological characteristics in some measure.

If, in the cases where the muscles retain their physiological functions, the eye habitually fixed is covered or rendered less serviceable in seeing than the other, then the usually squinting eye assumes the function of fixation, while the usually fixing eye deviates.

In heterotropia of this sub-class the rotations of the two eyes in various directions (except in the old and extreme cases above referred to) are nearly equal. Hence it is unnecessary to regard the anomaly as confined to one eye, even if one is habitually deviating. The practice (almost universal) of regarding one eye only as the squinting eye results in infinite mischief in the surgical treatment of strabismus.

**Class IV.**—This class includes—

1. *Anotropia*, *Anophoria*, a deviation or a tendency to deviate, on the part of both visual lines, above the most favorable plane for passive adjustment.

2. *Katotropia*, *Katophoria*, a corresponding deviation or tendency to deviation of both visual lines below the most favorable plane for passive adjustment.

In the most marked conditions of anotropia or katotropia, if either eye is in fixation the visual line of the other rises above the plane of fixation (anotropia) or sinks below that plane (katotropia), and if the second eye is made to fix, the visual line of the former fixing eye will rise or fall in the same direction as did the free eye which is now in fixation.<sup>1</sup>

In the large majority of cases these deviations cannot be thus perceived, and the conditions can be known only by the comparative upward and downward rotations of the eyes, which can be best determined by the tropometer. These lesser deviating tendencies are classified as anophoria and katophoria.

The methods for determining the existence and character of the defects included in these great classes of anomalies must differ to a greater or less extent for each class. The methods for each will therefore be considered separately.

#### CLASS II.—HETEROPHORIA.

As single vision is in these cases of heterophoria the rule, and as the voluntary, although unconscious, effort serves to maintain the just relations between the lines of vision, the existence and form of heterophoria can best be ascertained by inducing double vision.

<sup>1</sup> Stevens, Trans. Internat. Ophthal. Congress, 1884; Annales d'Oculistique, June, 1895.

If prisms of certain strength are employed, diplopia may be induced; and on the theory that, single vision being impossible, the voluntary effort to adjust the eyes will be withdrawn, it is assumed that the visual lines will take the direction which would be given by the minimum nervous impulse acting upon the eye-muscles.

This assumption is true only in a measure, and is often without foundation in fact, as it is frequently impracticable for the individual to permit the eye-muscles to become entirely passive.

Notwithstanding the imperfection of this theory, we possess no method of investigation in heterophoria so available as the artificial induction of diplopia.

Allied to this, but less uniform and therefore less useful, is the method of inducing contrasting images in the two eyes.

The simplest method of inducing double images is by the use of a prism. The principle governing the use of prisms for determining heterophoria, *but not the definite method*, is as follows:

If a prism of certain strength is held before one eye with its base directly up or down, double images will result; and on the theory of the passivity of the eye-muscles under such circumstances, if there exists no tendency of the visual lines to drift inward or outward, the images will be in an exact vertical line, provided that the object of regard is removed to a suitable distance from the eyes. This distance should be at least twenty feet. *No just appreciation of the muscular balance can be arrived at while the accommodation is considerably exercised or while convergence is required.*<sup>1</sup>

If in such suitably conducted experiment the images deviate from a vertical line, heterophoria is assumed, and its manifest extent is measured by a prism, placed with its base out or in, which will bring the images to a vertical line. If in this experiment the image seen by the right eye should drift to the right side (homonymously), esophoria would be indicated; if to the left (heteronymously), exophoria would be shown.

Let us suppose, the head being in the primary position, that a prism of  $8^\circ$  is placed before the right eye with its base directly down, and that diplopia is thereby induced. The image seen by the right eye will in this case be above, that seen by the left below. If now the upper image (that of the right eye) appears to the right of the other, we have an indication of esophoria. Taking a weak prism from the trial case, we may find whether it is sufficient, when it is placed with its base out before the other eye or before the vertical prism, to bring the two images to the same vertical line. If too weak, a stronger one may be used; or if the correction is overdone, a weaker one may be tried. The prism which neither leaves the upper image still to the right nor carries it to the left is the measure of the *manifest* esophoria. On the contrary, had the upper image (that of the right eye in

---

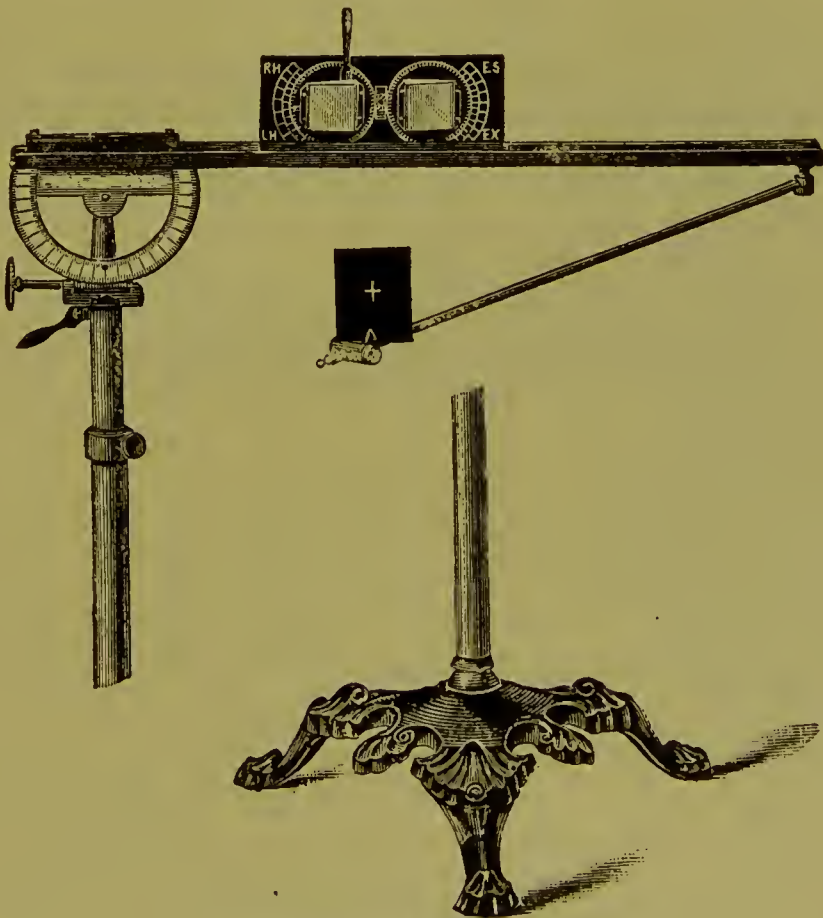
<sup>1</sup>Stevens, Archives d'Ophthalmologie, 1886; Anomalies of the Ocular Muscles, Archives of Ophthalmology, 1887, No. 2, p. 150.

this experiment) appeared at the left of the other, the prism which, with its base in, should bring the images to the vertical line would measure the *manifest exophoria*.

In like manner, if a prism of sufficient strength, with its base directly inward, should be placed before one of the eyes, diplopia would again be induced, and the images on the respective sides would belong each to the eye of the same side; that is to say, in this instance homonymous diplopia will have been induced.

If there is perfect equilibrium of the vertically acting muscles, the double images will be in the same horizontal plane, neither image being higher than the other. In case, however, the right image should appear *below* the other, a tending of the right visual line to rise above its fellow (right hyperphoria) is indicated; while should the right image appear *above*, left hyperphoria, or a tending of the left visual line to rise above, is indicated. In either case a prism that, with its base up or down, serves to make the images perfectly horizontal measures the right or left hyperphoria.

FIG. 4.



Stevens's phorometer with rotating slide.

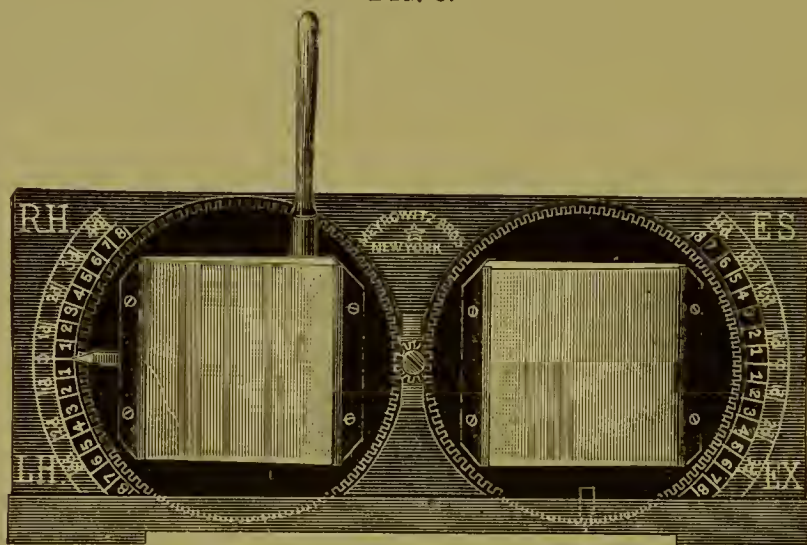
The method of determining the manifest heterophoria by the use of a prism held in the hand as just described or placed in a trial frame, although the simplest and most convenient of any, is subject to manifest and important disadvantages. It is not easy for one to know when the head of the examined person is exactly in what is known as the primary position,

nor can one always judge correctly regarding the position of a prism held in the hand or placed in a frame. A most important disadvantage, however, is the tendency on the part of the eyes to neutralize the correcting prism by making adjustments when the principal prism or the correcting prism is held near the eyes.<sup>1</sup>

In order to avoid these sources of error the *phorometer* was devised.<sup>2</sup> By its means tests giving the most reliable information which we are at present able to obtain in the determination of heterophoria are secured.

The improved phorometer has a standard and an adjustable arm furnished with a spirit-level, and a slide which contains two cells, in each of which rotates a disk, each disk carrying a prism of  $5^\circ$ . Each disk is furnished with a border of eogs. A small gear-wheel placed between the two disks communicates the movement from one disk to the other.

FIG. 5.



Rotating slide of phorometer. (The outer scale here shown is no longer in use.)

Around the outer part of the border of each cell is a narrow raised band, on which is marked a scale of degrees, increasing from the centre each way from  $0^\circ$  to  $8^\circ$ , the numbers representing the refracting power of prisms in diopters, the method of notation which will be used in this article.<sup>3</sup>

The scale represents a greater degree of accuracy and uniformity than the prisms found in the trial cases in common use.

The phorometer, when in use, should always be somewhat removed in front of the eyes. A distance of from four to six inches permits of much freedom in respect to the position of the head, while this distance also prevents in large measure, and in most cases entirely, the adjustments for neutralizing the corrections which may be made when the testing instrument is held near the eyes.

<sup>1</sup> These disadvantages have been discussed somewhat at length by the author in the *Ophthalmic Record* of January, 1892.

<sup>2</sup> *Medical Record*, May 5, 1888.

<sup>3</sup> The value of a prism of  $1^\circ$ , as used, will be equal to a refraction of one diopter, but the sign of the degree as formerly used will be maintained.

*Directions for using the Phorometer with Rotating Prisms.*—The phorometer should be so placed that the side of the slide on which the scales of degrees are seen should be *from* the patient. The side marked *RH* and *LH* will then be before the patient's right eye, and that marked *ES*, *EX* before the left eye. The arm of the instrument is to be brought to a perfect level, as indicated by the spirit-level. To determine *hyperphoria*, the instrument being adjusted to the height of the patient's eyes, and at least four inches in front of them, bring the lever of the prism slide to the vertical position. The pointer will then be at  $0^\circ$ . The patient, looking through the two glasses at an object (a lighted candle) placed at a distance of twenty feet directly in front, sees double images of the object.<sup>1</sup> Should one of the images appear higher than the other, the prisms are caused to rotate until the images are brought to the same horizontal plane. By making the rotation slowly it will in many instances be carried farther than when the correction is quickly made. The pointer then indicates the form and degree of manifest hyperphoria.

To examine for esophoria and exophoria, bring the lever to a horizontal position, and then make adjustments until the images are in an exact vertical line.

Instruments of less bulk, which can be carried about easily, in addition to the square prism which may be held in the hand, are sometimes useful.

*Rod Test for Heterophoria.*<sup>2</sup>—This consists of a disk of the size of trial lenses, which holds in the centre a glass rod. The effect of this transparent cylinder is to cause an apparent elongation of the image of a flame into a thin line of light quite dissimilar to the flame itself, as seen at the same time with the other eye, the theory being that there is a less peremptory desire to unite the two images, whose relative position thus approximately indicates the condition of equilibrium of the two eyes. The line is always at right angles to the axis of the rod, so that to produce a vertical line, with which to test horizontal deviations, the rod is placed horizontally, and to produce a horizontal line, to test vertical deviations, it is placed vertically.

With this instrument correcting prisms from the trial case may be used as in employing a simple diplopia test with a strong prism.

*Stevens's Stenopæic Lens.*—The purpose is also to present contrasting images to the two eyes.

<sup>1</sup> Should it happen that the prisms are not sufficiently strong to cause diplopia, a supplemental prism can be slipped behind the slide, with its base in, taking care that its axis is placed and remains horizontal.

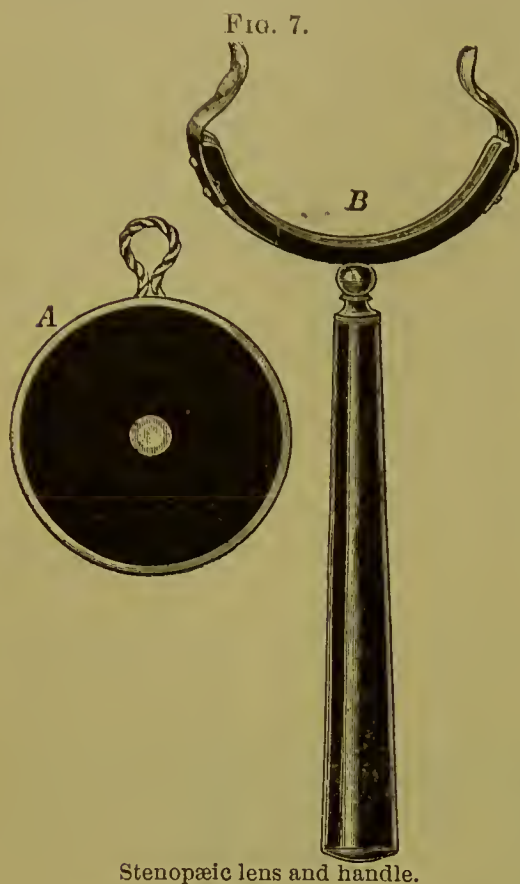
<sup>2</sup> E. H. Maddox, *Ophthalmic Review*, May, 1890.

FIG. 6.



Rod test.

With the lens the image of the candle-flame twenty feet distant, seen through the stenopæic opening, is a large and perfectly defined disk of diffused light.

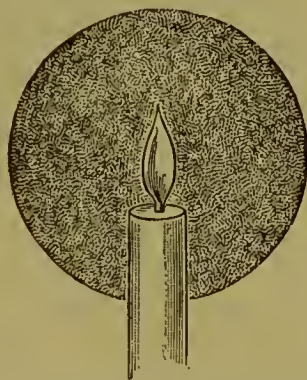


Stenopæic lens and handle.

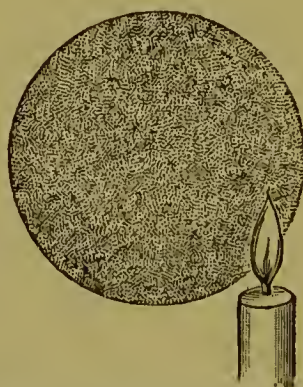
If a convex lens is covered, except at the optical centre, where a small opening acts as a stenopæic window, the small opening serves the double purpose of preventing an adjustment of the lens as a prism, and of cutting off the halo in such a manner as to give the impression of an exact disk of light bordered by a frame. A disk of the size of the lenses of the trial case, perforated by an opening of the required diameter and supplied with a perfectly centred lens of 13 D focus, is a convenient form. It may be used with a handle (Fig. 7 B), enabling the patient to hold it in his own hand, or it can be placed in the trial frame.

In orthophoria the untransformed image should be found exactly in the centre of the disk. In heterophoria it will tend towards or beyond the border. If the flame sinks below or rises above the centre, while at the same time it deviates laterally, we thereby discover by a single comprehensive view all the elements of a compound deviating tendency, so far, at

FIG. 8.



Position of candle flame in orthophoria.



Relative position of candle flame in heterophoria.

least, as that tendency is manifest. (Fig. 8.) In this important respect the stenopæic lens presents a feature both unique and of much significance.

The disadvantages of this instrument are those common to every instrument held close to the eye when in use in these examinations.

The theory that with such contrasting images the desire to make adjust-



ments with respect to the maculæ is suppressed has little foundation in fact. All such tests must be provisional and auxiliary, and it cannot be said that any of the class of instruments designed to be held near the eye possesses any marked advantage over the ordinary prism, while the prism has the advantage of more rapid use. There are other important elements of error in the use of all of this class of instruments for inducing contrasting images, which need not be discussed here. With these instruments rudely approximate results only may be reached. For determinations in which operations are to follow it is safer to trust to the phorometer.

If with the phorometer we could assume that the condition of all the directing muscles is in such a state of passivity as to permit of a registering of the absolute heterophoria, no further examination in this respect would be required. The practical fact is that the heterophoria manifest is often less than the absolute. We should therefore avail ourselves of all the means of arriving at a knowledge of the actual dynamic condition of the eye-muscles. We require also confirming tests in different ways, inasmuch as we may be misled by any single test.

The effort to unite, by the exertion of the force of the muscles rotating the eyes outward, images which have been separated by a prism with its base in, is known as *Abduction*.<sup>1</sup> The effort to overcome diplopia caused by a prism with its base out, by exertion of the muscles which rotate the eyes in, is known as *Adduction*.<sup>2</sup> The ability to overcome a prism with its base down before one eye is known as *Sursumduction*.<sup>3</sup>

A prism with its base down before one eye is equivalent in its action to a prism with its base up before the other eye.

The ability to unite images by overcoming the effect of a prism with its base down before the right eye or its base up before the left eye is known as *Right Sursumduction*. A corresponding ability when the prism is placed with its base down before the left eye or up before the right eye is *Left Sursumduction*.

The standard of abduction (uniting with a prism with its base to the nose) adopted by myself many years ago is  $8^\circ$  (prism).<sup>4</sup>

A prism of that grade should be overcome, and images of an object situated at not less than twenty feet distant should blend.<sup>5</sup> Many years of close observation have confirmed the correctness of this standard.

The ability to blend images of an object at a similar distance when prisms with the bases out are used (adduction) should be about  $50^\circ$  (prism), but this ability may be so greatly modified by practice that an exact standard of adduction is not to be expected. Yet, should the adducting ability fail

<sup>1</sup> Von Graefe, *Archiv für Ophthalmologie*, Bd. viii., 2.

<sup>2</sup> Von Graefe, *op. cit.*

<sup>3</sup> Stevens, *Archives d'Ophthalmologie*, November, 1886.

<sup>4</sup> *Op. cit.*

<sup>5</sup> If abduction is tested at a point removed less than twenty feet, the abduction should be greater: *e.g.*, suppose at fifteen feet, the abduction should be about  $10^\circ$ .

to reach  $50^\circ$  after a reasonable amount of practice, it is likely to be deficient.

The sursumduction ability is in the majority of cases about  $2^\circ$  (prism), but frequently in myopia of high grade and in some exceptional conditions in which myopia does not exist the sursumduction, both right and left, may reach  $9^\circ$ , or even more.

Applying these principles to an actual examination of the eyes, then, we learn, first, the record of the phorometer. We next apply the test for abduction, placing a prism of  $4^\circ$  or  $5^\circ$  with its base nasalward before one eye, while the examined person looks at a bright point,—*e.g.*, the flame of a candle twenty feet distant. If the images continue united, we may use a stronger prism. (The simple prism taken from the trial case is in every way the most convenient and satisfactory means of testing abduction.) If the images separate, we require the person examined to use strenuous effort to cause them to unite. If this is accomplished, we interpose a stronger prism, or use, in addition to the one already placed, a weak one before the other eye. Thus, step by step, we advance to the highest prism that can be overcome, which marks the abduction.

Then in similar manner the sursumduction may be tested; but between testing in one and the other direction for sursumduction some minutes must elapse.

Last of all the adduction may be tried.

Let us suppose that the phorometer has registered esophoria and exophoria and hyperphoria  $0^\circ$ , and that by abduction a prism of  $8^\circ$  is overcome by some effort; also that sursumduction right and left are equal. These are ideal tests, and indicate no manifest heterophoria. In the majority of such cases practical orthophoria may be thought to exist. Nevertheless, even these tests do not prove the absence of latent heterophoria, and even with such favorable tests an adjustment above or below the most favorable plane may exist for both eyes.

Let us next suppose the phorometer to indicate esophoria  $3^\circ$ , hyperphoria  $0^\circ$ , abduction  $5^\circ$ , and sursumduction right and left each  $2^\circ$ . We may without hesitation assume that there is a simple manifest tendency of the visual lines inward, and we may at once hand to the patient spectacles of  $1^\circ$  prism, base out, for each eye for temporary use. This is  $1^\circ$  less than the manifest esophoria, as it should be in nearly every instance.

Let us make a third supposition. We have esophoria  $0^\circ$ , exophoria  $0^\circ$ , hyperphoria  $0^\circ$ , with abduction not exceeding  $5^\circ$ . This restricted abduction may indicate esophoria which by virtue of a sufficient effort the patient renders latent, or it may represent the existence of a moderate element of hyperphoria, but more frequently it indicates a tendency on the part of the visual lines of both eyes to rise above the most favorable plane (anophoria), or to fall below it. It is best to wait before applying a temporary prism until a second or third examination. Then, if the tests continue as before, and there is no symmetrical excess in the rotations up or down, we may use

a prism of  $1^\circ$ , permitting the patient to use it a day or two continuously. If we have to deal with simple esophoria, we are likely to find that the tension of the muscles has somewhat relaxed, and that esophoria in excess of the glass will be shown by the phorometer.

On the other hand, should the abduction be in excess, while no exophoria is manifest, we may again suspect either hyperphoria or a tendency of both visual lines above or below the best plane. We may, with equal care, use a weak prism with its base in, when, if exophoria beyond the prism becomes manifest, we may follow as closely as, in our judgment, the case may demand.

We have greater difficulty when by the phorometer we find exophoria with abduction considerably below the standard, or esophoria with excessive abduction. In general, we shall find the existence of anophoria or katophoria by the tropometer, or in the absence of these we may assume the existence of latent hyperphoria, and perseverance should be observed in the efforts to render it manifest. Corrections of esophoria or exophoria by operative means should not in this class of cases be attempted before all the tests are brought into harmonious relations.

It should not be forgotten that the manifest heterophoria is usually only a portion of the absolute heterophoria,<sup>1</sup> and that, in order to reveal more approximately the absolute defect, repeated examinations should be made and approximate means for relaxing the tensions of the muscles should be employed. The use of temporary prisms was adopted by me and suggested to the profession several years ago, and the rule then announced, that such prisms should be of less grade than a nominal correction of the known defect, in order that an apparent anomaly be not induced by the correcting glasses, should be carefully observed.

These temporary prisms, which should follow but should not lead the anomaly, may be increased in strength from time to time, as the case may require. For example, should a patient manifesting  $2^\circ$  esophoria use a prism of  $1^\circ$  for a day or two, a larger record of the anomaly is likely to be made, and the patient may safely use a prism of  $1^\circ$  for each eye, and thus an advance by careful increase of the correcting glasses may be made. But if this method is practised while an important condition of anophoria or katophoria is present, the resulting esophoria or exophoria may be the manifestation of the vertical tension only.

In the temporary correction of hyperphoria the same general principles apply.

Nothing has been said thus far of testing at near points, because tests of the state of the ocular muscles made at near points have no direct value.<sup>2</sup> It may, however, in certain cases be found advantageous to ascertain the action at the reading distance as a collateral test.

In the best condition of equilibrium there will generally appear exo-

---

<sup>1</sup> Stevens, Archives d'Ophthalmologie, 1886.

<sup>2</sup> Op. cit.

phoria in accommodation  $4^\circ$  or  $5^\circ$ , and this should be taken into account in adjustments for glasses for reading; for if the exophoria in accommodation as shown by a prism is abolished, the patient is given a practical esophoria.

This important point in adjusting reading glasses often demands careful attention. By pursuing the following very simple method, the comfort to be obtained from glasses designed for use only at near points may be materially increased.

The proper glasses having been selected, place them in one of the adjustable trial frames in common use, with the optical centres at the height of the pupil. Then adjust the phorometer for exophoria  $5^\circ$ , and bring the slide within one or two inches of the eyes of the patient. Hold a card, on which is a single dot, or through which is made a small opening, in front of the instrument and at the distance of ordinary reading. Now, by means of the screw of the adjustable trial frame, bring the two images of the dot or other mark to a vertical line. Measure the distance between the optical centres, which is the distance at which the optical centres of the permanent glasses should stand. Some cases require the adjustment to be for rather more than  $5^\circ$ .

The *power of convergence* should also be observed, but by itself, as a separate phenomenon, it gives us little important information. Indeed, insufficiency of convergence is not infrequently associated with a tendency of the visual lines inward amounting to actual squint.<sup>1</sup>

As a good converging ability may be absent, even if there is marked deviation of the visual lines inward, so there may be excessive converging power when exophoria of a high degree is manifest.

The fact of a deficient converging power associated with esophoria is indicative of anomalous tensions in the vertically acting muscles, in the form either of hyperphoria or of an unfavorable tendency of both visual lines to rise above or fall below the horizontal plane of the primary position. This absence of converging power should warn the surgeon against the assumption that he is dealing with a simple case of esophoria. Similar caution should be observed in cases of excessive convergence associated with a high degree of exophoria.

Observation of the movement of an eye as it passes from exclusion to fixation may also afford information of importance. This method of observation is a useful one, which will not be discussed in this place. It will be described later.

#### CLASS III.—HETEROTROPIA.

Turning from those conditions of the eye-muscles in which binocular vision is not only possible but habitual, to those cases not pathological (subclass *a*) in which diplopia (conscious or unconscious) is the habitual and single vision the exceptional condition, even if the latter is ever possible, we find

<sup>1</sup> Stevens, Archives of Ophthalmology, 1889, p. 337.

occasion to vary our tests. In a large proportion of the cases of this class we are forced to accept, tentatively, for certain classes of tests rude approximations to the truth. Too little attention to such examinations as can be made in heterotropia leads to unfortunate results in the operative treatment. No really valuable success in the attempt to establish binocular vision in cases of squint, by operation or otherwise, can be attained without an acquaintance with the details of the relative tensions of the various eye-muscles.<sup>1</sup> To this end a knowledge of the relative positions of the images of the two eyes is essential.<sup>2</sup>

The determination of these positions is rarely easy, and is often extremely difficult. In many cases of strabismus the patient is at first unconvinced of the fact of his diplopia, and in such cases the patience and skill of the surgeon are put to the test.

In arranging the discussion of the means of determining the character and extent of heterotropia, the cases may be conveniently grouped according to the comparative case with which the examination may be made.

In physiological heterotropia of slight extent, and in cases in which double images are recognized without much difficulty, we may proceed in much the same way as in heterophoria. In many cases it becomes necessary to give to the images of the two eyes contrasting colors, which is best done by placing a red glass before one eye, usually the best seeing eye. If the patient with this contrast recognizes the two images (*e.g.*, the flame of a candle at twenty feet), we may learn their relative positions.

1. If they are not in the same horizontal plane, we employ prisms from the trial case to bring them to such a plane, placing the prism or prisms with the bases up or down, as may be required, to effect this purpose. If the image seen by the left eye is higher than that seen by the right, there is *right hypertropia* measured by the prism that brings the images to the same level. In *left hypertropia* the right eye image appears above.

2. If the images are seen separated in the lateral direction, we learn whether the images are homonymous (esotropia) or heteronymous (exotropia), and in either case we ascertain the strength of the prism required to bring them together, or, if they are not in the same horizontal plane, to the same vertical line. In many cases of low degree of heterotropia the phorometer (with, perhaps, the aid of a colored glass) will best serve in making the determinations.

In the trials above described, the prisms which served to unite images and thus correct the heterotropia do not necessarily indicate the absolute tensions which induce the deviations. Indeed, they may come far short of it. The phorometric measurement will, however, most nearly approximate to the actual condition.

---

<sup>1</sup> Stevens, Archives of Ophthalmology, 1889.

<sup>2</sup> It cannot be too strongly impressed upon the mind of the student of this subject that measuring squint by so-called strabometers must be abandoned by one who proposes to operate for squint with the view to ultimate good binocular vision.

In a second group of cases greater difficulties are encountered. The image of one eye has been so long mentally suppressed that the patient rejects the idea of diplopia. The difficulty is in some measure removed if the examination is conducted in a room dark except for the light of a candle at the farther side from the patient. By repeated changings of the relative positions of the two images, such as may be induced by placing a strong prism in various directions, at the same time instructing the patient when and how to direct attention in the search for the second image, success may crown the efforts, perhaps, after many days. The patient may in certain cases be aided in his search if an assumed partial correction by prisms of pretty high grade is permitted to remain in the trial frames while the changes are made by a free prism.

An approximate estimate of the deviations and their directions may be made by the examination of the *deviations in exclusion*.

In the examination of the deviations in exclusion we find two elements,—the first being the movement which can be observed by the examiner as the patient brings one or other eye from exclusion to fixation, the other the lesser movement, which the examiner cannot perceive, but which may be recognized by the patient in the slight apparent movement of the object looked at as the small screen (*e.g.*, a small visiting-card) is passed from in front of one eye to in front of the other. This little movement of the object as observed by the patient has been called by Dr. Alexander Duane the parallax test. The examiner should observe the movement of the eye as it changes from exclusion to fixation, and neutralize the movement with prisms so long as it can be observed by himself. The observation of the patient is then brought to bear, and stronger prisms are, if necessary, used until the patient can detect no further movement in the original direction. A movement in the opposite direction indicates an over-correction.

The extent of movement ascertained by the observation of the examiner and by that of the one examined may be recorded under the term *Deviation in Exclusion*.

In a great proportion of cases of heterotropia this deviation is compound, and the different elements of the deviation should be carefully estimated.

It not infrequently occurs that each of the eyes may be seen to deviate up behind the screen while the other is in fixation (anotropia), or down in like circumstances (katotropia). In such cases a prism before a single eye does not neutralize the movements, but symmetrical prisms before both eyes may do so.

The positions of the double images in cases of considerable deviation are sometimes misleading. It may happen that crossed diplopia is observed while there is marked convergent squint, and homonymous diplopia when the eyes as evidently turn outward. In such cases great caution should be observed in respect to operative correction, for, although it may not be easy to demonstrate, there is presumably a vertical deviation as well as a lateral

one.<sup>1</sup> Indeed, such a vertical deviation should always, when incongruities of this kind present themselves, be assumed to exist.

It may therefore be advisable that operative corrections be made for much less than the apparent deviation, thus bringing the visual lines into closer relations, when the actual deviations can be better studied before proceeding to the final corrections. If, however, there is an important defect in the rotations in the lateral or in the vertical direction, as shown by the tropometer, such defect should receive the first attention.

A third group within this class presents still greater difficulties. In the cases of this group one eye has become so completely amblyopic that the patient either fails to recognize the existence of such an object as a candle-flame by the use of that eye, or if, after some search, he is able to discover it, it is located far to one side of the field of regard, and he is absolutely unable to locate the position of the object in space. Here, again, partial operative correction may be made of the apparent strabismus, careful tropometric measurements being taken into consideration, and then time allowed for the patient to learn to recognize the true position of the object. In most instances, if reasonable attention has been given to the indications of the tropometer in making these tentative corrections, a few months serve to enable him to do this, but in exceptional cases the ability to locate by the amblyopic eye remains wanting after many months.

#### CLASS IV.—ANOTROPIA, KATOTROPIA.

From what has already been said, it will appear that many cases of esotropia and exotropia, esophoria and exophoria, depend upon the unfavorable tensions of the vertically acting muscles, and the rotations of the eyes in the vertical directions should be studied in interpreting the deviations and tendencies in or out.

The eyes should rotate upward at least  $33^\circ$  (of arc) and downward at least  $50^\circ$ . (In old age these rotations are lessened.) The nasal and temporal rotations should be each from  $48^\circ$  to  $53^\circ$ . An excess of  $33^\circ$  upward or of  $50^\circ$  downward should be regarded as anomalous. If in a case of converging or of diverging strabismus the temporal and nasal rotations do not greatly vary from the normal, care should be observed in regard to operations on the interni or externi, inasmuch as extreme cases of squint often arise largely, or even entirely, from vertical tensions.

The tropometer is designed to measure the rotations of the eye in all directions.<sup>2</sup> It consists of a telescope in which an aerial image of the cornea is formed near the eye-piece. A scale, graduated to measure the rotations of the eye in all directions, is placed at the point where the image is formed.

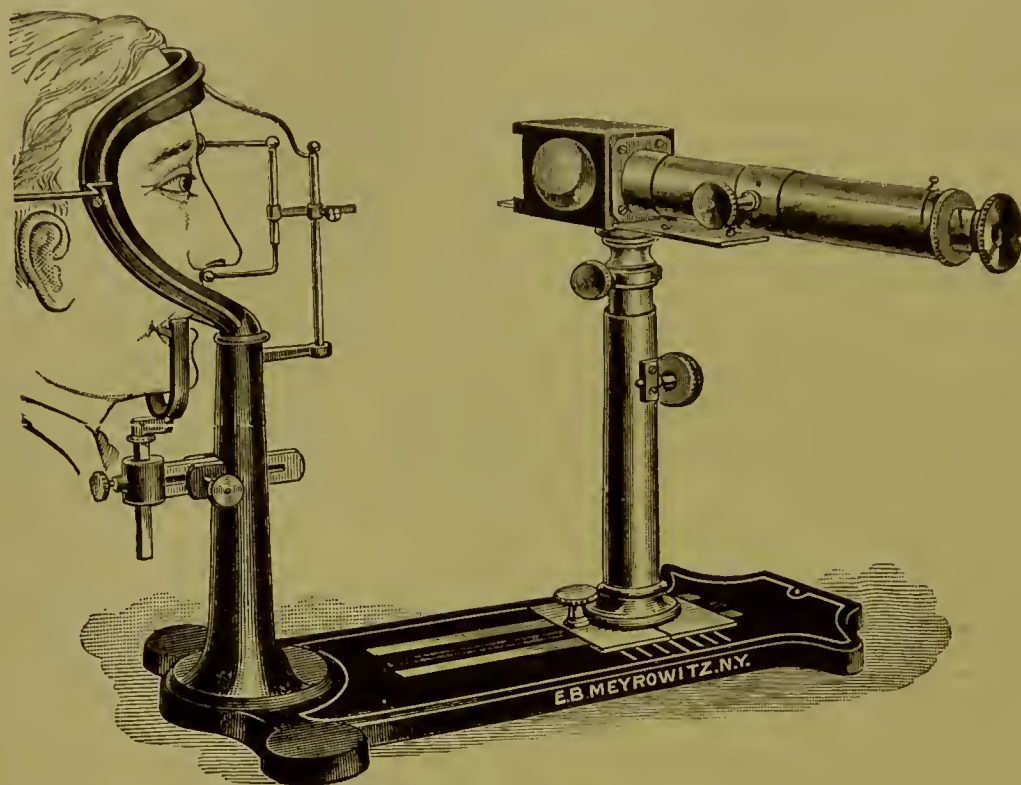
The scale of the tropometer is represented in Fig. 10. After placing

<sup>1</sup> Stevens, Archives of Ophthalmology, 1889, p. 329.

<sup>2</sup> Annales d'Oculistique, July, 1895.

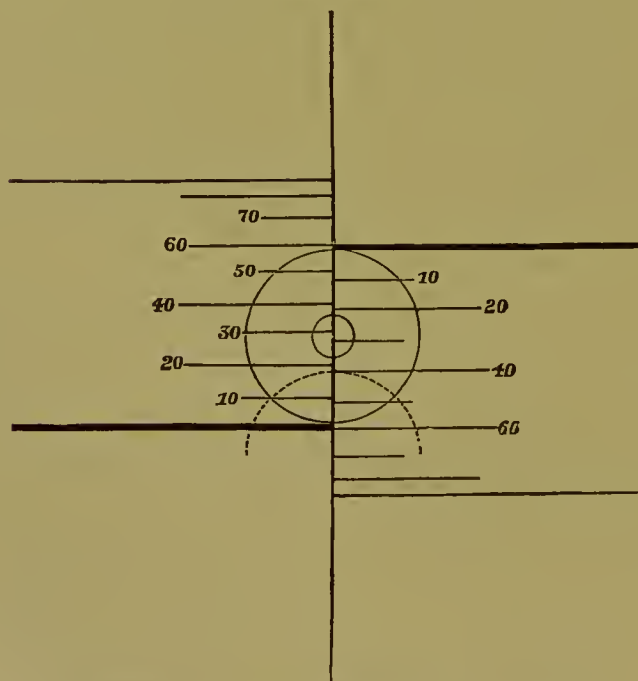
the head in the rest in such a way that the two selected points—the glabella and the commissure of the upper lip—are exactly vertical, the instrument is to be so adjusted that the border of the cornea is exactly in contact with the

FIG. 9.



The tropometer.

FIG. 10.



Tropometer scale as seen magnified by the ocular.

line *a* or *b*, while the observed eye looks directly at a spot at the centre of the object-glass. The person examined is then directed to rotate the eye in the given direction to the greatest possible extent, while the head is kept



strictly immovable. The rotation of the eye, as indicated by the change of position of the border of the cornea, is shown at *e*.

#### EXAMINATIONS OF PARALYSIS OF THE OCULAR MUSCLES.

(HETEROTROPIA, SUB-CLASS *b*.)

The diagnosis of paralysis and the determination of the muscle specially affected may be made by observation of (*a*) the rotating ability in various directions, and of (*b*) the diplopia which usually results when the eyes are turned in certain directions.

Double vision is the phenomenon which generally calls attention to the existence of paralysis, and it is through the peculiarities in the manifestation of this phenomenon that the most valuable data for the localization of the affection are obtained.

In a small proportion of cases, notably those which, originating in infancy, have been of long standing, double images are mentally suppressed. In the great majority of cases, however, the double images, the false projection, and the frequently accompanying vertigo, all of sudden accession, compel a recognition of the anomalous condition.

The fact of the existence of paralysis of one or more muscles having been ascertained, we may in many instances, by a careful examination of the rotations of each eye, by general inspection, and by tropometric measurements, determine not only to which eye the affected muscle belongs, but the muscle or muscles which are at fault. For example, should it be found that double vision in the horizontal plane on looking to one side has been developed (binocular vision having previously existed), and that the temporal rotation of the right eye is much restricted while that of the left is free, we may assume that the external rectus muscle of the eye with the restricted rotation is the affected one.

It is not always so easy to determine the restrictions of rotation, especially when the paralysis is quite incomplete, or when the oblique muscles are the seat of the affection.

In examining the rotation the examiner may hold an object—for example, a pencil—before the eyes of the patient, and direct him to follow with his eyes all its movements while the head remains immovable. Still better, he may arrive at correct results by the use of the tropometer. If there is marked restriction in either of the lateral or of the vertical movements, the observer carefully compares the rotation in this respect with that of the opposite eye and with what should be the normal extent of the movement in question.

In marked paralysis of any single rectus muscle this examination is sufficient to enable the examiner to locate the affected muscle.

In more obscure cases the determination of the disabled muscle is made by the relative positions of and the variation of the distances between the double images as the gaze is directed towards different points.

The image lying farthest in the direction in which the separation is

greatest always belongs to the affected eye. The farther the gaze is turned in the direction of the affected muscle the farther apart the images will appear.

Let us, for example, suppose a paralysis of the internal rectus of the right eye. If the gaze is turned towards the right, there will be no diplopia; but if directed towards the left, towards the affected muscle, diplopia at once occurs, and increases in proportion to the extent of the turning. In this case the right-eye image passes to the left, while the left-eye image is seen at the right. Bearing in mind these two rules,—first, the rotation is restricted in the direction of the affected muscle, and, second, diplopia increases in the direction of the action of that muscle,—we can without difficulty, by means of the following scheme, locate the paralyzed or paretic muscle in cases of affection of a single muscle.

#### GENERAL SCHEME OF DIPLOPIA IN PARALYSIS OF THE OCULAR MUSCLES.<sup>1</sup>

##### *Diplopia caused by lateral rotations in the median plane.*

Images homonymous, paralysis of the externus of the eye towards which the rotations cause the greatest separation of the images.

Images crossed, paralysis of the internus of the eye towards which the rotations cause the least separation.

##### *Diplopia induced by vertical rotations above the median plane.*

The higher image belongs to the affected eye.

Images homonymous, paralysis of the inferior oblique of that eye.

Images crossed, paralysis of the superior rectus of that eye.

##### *Diplopia induced by vertical rotations below the median plane.*

The lower image belongs to the affected eye.

Images homonymous, paralysis of the superior oblique.

Images crossed, paralysis of the inferior rectus.

Coexisting exophoria of sufficient degree may cause the images in paralysis of the obliques to become crossed; and esophoria, in like manner, may cause the images in paralysis of the superior and inferior recti to become homonymous. In such case diagnosis may be aided by the tilting of the images. If the tilting of the upper end of one image inward increases with the rotation above or below the median plane, paralysis of the rectus muscle is suggested. If the tilting of the upper end outward increases with the rotation above or below the median plane, paralysis of one of the obliques is suggested.

Examinations of the extent of diplopia in paralysis may be roughly estimated by the perimeter. Those described in some of the text-books scarcely serve to indicate the rotations of the visual lines. A method described by the author<sup>2</sup> is more satisfactory, but even this gives only a vague idea of the real condition.

<sup>1</sup> Stevens, Ophthalmic Record, July, 1894.

<sup>2</sup> Proceedings of the International Medical Congress, Washington, 1887.

# PERIMETRY AND ITS CLINICAL VALUE.

BY HERMAN WILBRAND, M.D.,

Ophthalmic Surgeon to the General Hospital of Hamburg, Hamburg, Germany.

TRANSLATED

BY THOMAS R. POOLEY, M.D.,

Formerly Professor of Ophthalmology in the New York Polyclinic; Surgeon to the New Amsterdam Eye and Ear Hospital, New York City, New York, U.S.A.

## GENERAL PART.

By the field of vision we understand that part of space which is simultaneously perceptible to an eye during sustained central fixation. That angle which two visual lines drawn to the terminal points of an observed object form together is known as the visual angle. If all the cones lying along the periphery of the retina (*ab* and *cd*, Fig. 1) be drawn outward into space, they will embrace a cone (Fig. 1) whose apex lies in the nodal point of the eye. The base of this cone, *g'g'* or *h'h'*, represents a field of vision projected either upon a flat surface, *gg*, or upon a hollow sphere, *hh*. The fixation-point *F* lies in the visual field at the point where the base of the cone is cut by its axis. If the distance along the visual axis *mk* be increased, the base of the cone, and, consequently, the visual field, will increase in equal extent until at an infinite distance it will become infinitely large. Clinically it is best to obtain the field of vision

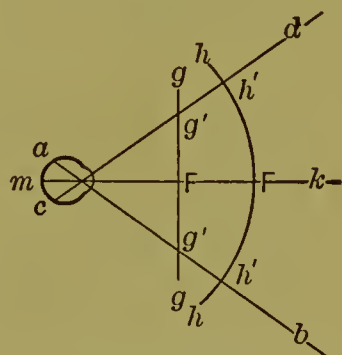


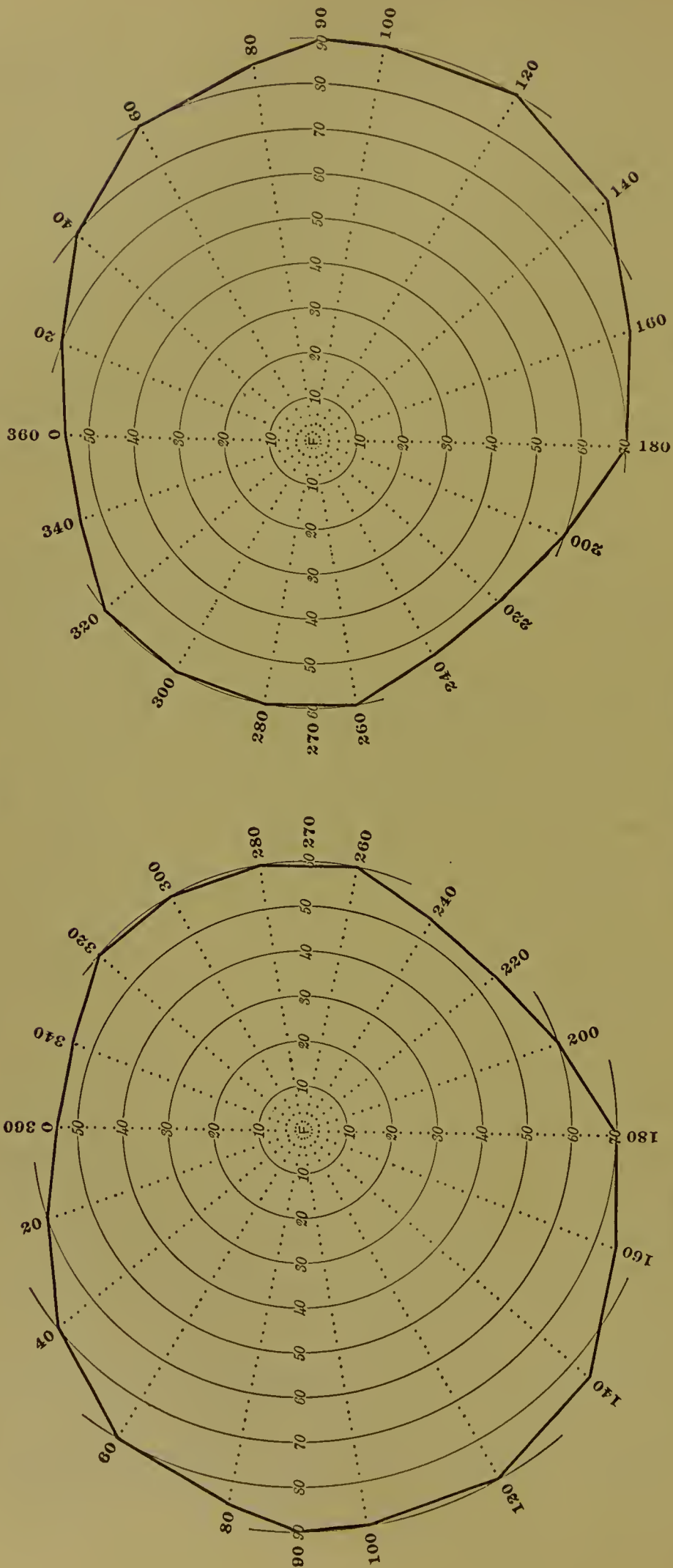
FIG. 1.

Scheme to illustrate the field of vision.

upon a graduated blackboard placed at a fixed distance from the eye, or upon a graduated hollow sphere known as a perimeter. Along the separate meridians of the blackboard *gg* or the hollow sphere *hh* a white or colored object of a fixed area is to be moved towards the fixation-point *F*, which lies in the centre of the graduations, and the points at which the object is first perceived in the periphery of the meridian are then to be noted. The results are entered upon a diagram (Fig. 2) representing the various graduations.

In order to be able to draw proper conclusions for the comparison between fields of vision found in pathological conditions, it is necessary to establish an average form and extent of a normal field of vision in the healthy emmetropic eye. Since in the cortex, in the region of the calca-

FIG. 2.1



Right field.

Diagram of fields of vision.

Left field.

<sup>1</sup> It will be noticed that in this and all the succeeding charts of fields of vision the angles are designated in a different manner from what is customary in English-speaking countries. It has not, however, been thought worth while to alter the beautiful graphic work of the author or to make any relative changes in the tables.

rine fissure upon each hemisphere, the stimuli conveyed from the retina become transformed into their physical correlative, light-perception, and since certain areas of these cortical sight-centres, as well as certain groups of fibres of the conductive apparatus, stand in functional relations to certain parts of the retina, it follows that all lesions which affect the long path from the retina to the ganglion-cells of the cortex, the fibres of conduction, the primary centres, and the cortical centres of vision cause a deficiency of the sensation in those parts of the field of vision which stand in direct anatomical connection with the diseased portions of the apparatus. Again, as the measurement of the visual field and the registration of the obtained results in fixed diagrams have made it possible to represent graphically the intensity and extent of existing visual disturbances and to compare these pictures with one another, it can be proved that certain defects in the field of vision correspond with certain disease-processes. Moreover, a more precise diagnosis has been rendered possible by this method in lesions of those parts of the optic tract in which the ophthalmoscope cannot afford any assistance. Perimetry has obtained a still greater diagnostic importance, since careful study of the results of microscopical examination, with exact sketches of the field of vision, has widened our knowledge about the partial course of the fibres in the optic tracts, and seems about to fix the distinguishing symptoms under which neuritis, primary atrophy, and purely functional disturbances make their appearance in the visual field, as well as with regard to their prognosis and treatment.

In every case, however, the method is of diagnostic value only when central visual acuity, light-sense, and the ophthalmoscopic appearances have been determined.

As visual acuity is greatest in the fovea centralis, and as in the normal eye the ball is placed in such a way that the image of an object is projected upon the macula lutea, it seems natural that this point should be considered as the centre of the field of vision. The measurements of the field of vision in normal eyes have proved that the limits of the visual field are not situated at the same distance from this point of fixation in every meridian, but that the boundaries represent a rather irregularly shaped horizontal oval. (See Fig. 2.) This form depends chiefly upon the extension of the anterior parts of the retina, the retina extending farther forward on the nasal side than on the temporal, and therefore, upon account of reversed projection, the field of vision must have a greater extent outward. (See Fig. 2.)

Still another series of circumstances influence the normal extent of the field of vision. Foremost are the bones which surround the edge of the socket, and the soft parts which cover them; the bridge of the nose, which limits the extent of the visual field inward; the tip of the nose, which contracts it inward and downward; and the cheek, moustache, and lips, which limit it downward. The width of the lid-opening, the narrow-

ness of the pupil, and the position of the pupil plane also lessen it. In the binocular field of vision a part of these limiting factors is missing.

The wider the pupil the greater becomes the extent of the field, because rays of light can then strike the more anterior parts of the retina. If, for example, as during accommodation, the plane of the pupil advances, or if the depth of the anterior chamber is diminished, as in hypermetropia, visual lines placed through the margin of the pupil and the nodal point will be able to reach farther forward than when the anterior chamber is deeper, as in myopia. The field of vision is also diminished by the longer optic axis of myopia, because the peripheral parts of the retina then lie at a greater distance from the plane of the pupil. The contrary is the case in the shorter optic axis of hypermetropia.

A part of these factors may be easily removed by raising the lids and eyebrows, by turning the head in the direction of the nose, and by throwing the head slightly backward. The disturbing elements of myopia may be avoided by the use of concave glasses, and lack of accommodation overcome by corresponding convex glasses.

There are three methods of obtaining the field of vision. The easiest, but the most primitive, is to determine the field by the hand. The second is to obtain it by a graduated blackboard. The third, which is the best and most scientific, is to employ the perimeter.

In the first, the patient is placed with his back towards a window, at about one to two feet from the examiner, who brings his own eyes to the same height as the patient's. When the right field is to be examined, the patient is to be directed to look constantly with his right eye into the examiner's left. He is then to be asked whether he perceives the different movements of the examiner's hands by indirect vision. At the same time the examiner controls the fixation of the patient's eye with his own eye. To render the examination more precise, white and colored squares of paper of a fixed size may be employed instead of the hand. This rough method of examination may in many cases give distinct hints whether there are defects in certain directions, or whether there is concentric contraction. Ill defined scotomata and small defects remain undiscovered by this procedure, and it is impossible accurately to represent them upon a diagram.

In some forms of hemianopsia in patients who are in a semi-conscious state, in individuals with sensory aphasia, and in cases of weakness of mind, as paralytics and certain apoplectics who cannot be examined by the perimeter, we may make use of the so-called winking reflex for the determination of the defective part of the visual field. To do this a light is to be approached from one side into the field of vision, but not so near as to permit any heat-reflex, and notice taken whether there is any reflex closure of the lids. In the first type of cases the half of the field of vision within which this reflex is wanting corresponds to the opposite or functioning part of the retina. Since in somnolent patients the eyes

generally remain at rest, it is not necessary in such instances to provide for fixation. For this method the wire of an electric battery which can be suddenly brought to a glow in a dimly lighted apartment is the best form of apparatus for the procedure. In order to obtain proper fixation in children or some adults with sensory aphasia, an assistant can hold a brilliant object one-half a metre's distance in front of the eye. By this means the attention of the patient is caught. A peripheral light is then moved from different directions towards the object of fixation, and observation made as to when the attention of the patient is diverted from the fixation-light to the second light. By frequently repeated examinations of this kind a clear idea about the existence of defects can be obtained. All noise must be avoided, and it is a good plan to have a dark cloth held before the patient.

Large squares of white and colored paper can also be used to advantage. To test the field of vision in an individual with ripe cataract the following procedure may be tried. In a dark room is placed a lamp behind and to one side of the patient. He is then told to look straight forward. The reflection of a flame is thrown from an ophthalmoscope into the eye from different directions. If the field of vision is good, the patient can state exactly from what point the light has been thrown into his eye, thus proving roughly that light-projection is unhindered. During this test, however, the reflexes produced by the opacity of the refractive media form an impediment, and it is often difficult for the unintelligent to differentiate between the vague general impression of light and the real situation of the flame.

The second plan is to employ a graduated blackboard. This method was introduced by von Graefe,<sup>1</sup> and considerably improved by de Wecker.<sup>2</sup> The patient is placed at a definite distance from a blackboard, upon the centre of which he is made to fix. The surface of the board is divided into meridians and concentric circles. A piece of chalk is advanced along the different meridians towards the centre of the board (fixation-point), and the places marked upon which the object first becomes visible. On the board constructed by de Wecker the chalk is replaced by white ivory balls which can be moved along the different meridians.

This method suffers from the fault that the various parts of the retina are measured at different distances.<sup>3</sup> In Fig. 3,  $DG$  represents the surface of the blackboard and  $F$  the point of fixation. Here the distance of the macula lutea ( $f$ ), which is directed to  $F$ , is equal to  $fF$ . The point  $c$ , which is at a distance of forty degrees from the macula ( $f$ ), is at a distance  $cc$  from the retina. The point  $d$ , lying at eighty degrees from the macula, is at a much greater distance,  $dD$ .

<sup>1</sup> Archiv für Ophthalmologie, ii. 2.

<sup>2</sup> Klinische Monatsblätter für Augenheilkunde, 1867, S. 275.

<sup>3</sup> Carl Möser, Das Perimeter und seine Anwendung. Inaugural Dissertation, Breslau, 1869.





point, which lies opposite the eye, at the pole of the arc as zero, the arc is divided into ninety degrees towards each side; upon the small upper and lower surfaces  $g, g'$  of the arc the numbers of the separate concentric circles can be read off. By turning the arc upon its axis it can be placed in every meridian of the field of vision, and the position of the meridian last taken can be read by means of the meridian hand  $l$ , which moves in the same direction as the ring  $b$  over a graduated disk  $m$ .

By this means the eye is placed in such a manner that it lies just over the ledge  $f$ , while the other eye is covered with a shade. The patient is then directed to fix. A comfortable seat and an unconstrained position of the head are of great importance in securing the long attention which is required. Both conditions are best brought about by seating the patient on a revolving chair and placing the perimeter upon an adjustable table-top. With the aid of the movable chin-holder, the revolving stool, and the perimeter-table, children as well as the largest adults can be seated properly. A good plan is to place the perimeter between two windows, with the concave side of the arc turned towards the incoming daylight.

On the opposite side the instrument is surrounded by a high partition, covered with unglazed black cloth, in order to prevent the patient's attention from being diverted by brilliant objects and thus influencing the light-sensibility of the retina. All visible surfaces of the instrument and the table-top are painted dull black. The examiner should be dressed in a long, dull-black coat, and his right hand covered by a black glove. The examination-object is moved by means of the sliding apparatus originally placed on Förster's instrument, from the periphery of the arc towards the centre. The number of the concentric circle upon which the object is first recognized is read and noted upon a diagram that is graduated in a way as if one were to gaze at his own field of vision. (Fig. 2.) During the examination of the upward limits of the field it is necessary to elevate the upper lid with a finger, and if the forehead and eyebrow project much, it is well to raise the chin-holder in order to tilt back these structures. It is absolutely necessary to move the object to and fro when examining the peripheral parts of the field of vision, because during strict and constant central fixation a resting object disappears much too fast, in consequence of simultaneous light-induction. (Hering.)

To mark the limit for a white object it suffices to note the places where the patient gets the sensation of the appearance of a light spot. For the determination of the peripheral limits of colored objects the sensation of color must be present. Instead of Förster's slide, which makes a sound, and by it informs the patient of the approach of the test-object, dull-black rods, fifty centimetres long, to the end of which the object is fastened, can be substituted.

The test-objects generally employed are white and colored squares of five millimetres each. The colored objects are made of so-called Heidelberg flower-paper. For the examination of high grades of amblyopia,

white and colored squares of ten, twenty, and more centimetres' side-length are often necessary for employment. Likewise, squares of one or two millimetres' side-length for the discovery of small central defects in the field of vision are of value.

The fixation-point must neither be too large, because then the eye moves to and fro, nor too small, since the fixation of a very small object is more fatiguing, and because during constant fixation it disappears rapidly, in consequence of simultaneous light-induction. The manner of sketching the field of vision as shown in Fig. 2 is, properly speaking, not exact. Such a diagram is neither the projection of a hollow sphere upon a plane nor an expansion on a plane, yet it is well adapted for sketching the limits of the field. It is true that the defects become somewhat distorted in form, since they are more diminished in the meridional than in the equatorial direction (the projection of a hollow sphere upon a plane spreads much more in the meridional direction); but, as this mistake remains the same for all examinations, it may be disregarded. A correct representation of the field of vision is possible only upon a hollow sphere.

#### NORMAL FIELD OF VISION.

The extent of the normal field depends upon individual difference; this explains why most observers have obtained such different values for it.

It is necessary to distinguish between an absolute and a relative limit, because each retinal periphery when the organ is at rest has a zone of perceptive elements that are acted upon by feeble light. The width of this zone is calculated from the considerable expansion brought about by the action of strychnine, which increases the susceptibility of the entire retina and at the same time moves the plane of the pupil forward so that a great number of peripheral cones which were acted on by too feeble light now receive more dispersed rays, this addition being sufficient to produce a sensation of light and thus increase the field of vision. This assumption of the limit of the field agrees with the experience that it becomes wider by repeated examinations, and likewise that a greater field of vision is obtained if the trial-object is moved from the centre to the periphery than if it is moved from the periphery to the centre.<sup>1</sup> The assumption is further substantiated by the fact that the field of vision is made larger and rounder through the use of strychnine (von Hippel) and by using very bright objects. (Schweigger.)

The limit indicated in Förster's diagram (Fig. 2) may be taken as the minimum size of the normal eye for a five-millimetre-square white object. The normal field has its largest area in the horizontal meridian, and the smallest ones in the vertical and lower inner meridians.

From the fixation-point the acuteness of vision rapidly diminishes. The curves of equal eccentricity, called isopters by Hirschberg, were determined

<sup>1</sup> Lievin, Ueber die Grösse und Begrenzung der normalen Gesichtsfelder. Inaugural Dissertation, Königsberg, 1877.

by him by means of the large test-letters of Snellen. The more nearly physiologically correct, and for perimetric diagnosis the more useful, is the method of Groenouw, who determined the isopters by means of the points of most acute vision.<sup>1</sup> The term acuteness of vision is applied to two different functions of the retina: (1) the ability to distinguish a small point from its environment, termed acuteness of vision for points; (2) the ability to differentiate two or more objects, termed acuteness of vision for form. Aubert calls the smallest perceptible point the "physiological point." Groenouw has determined the isopters for points of different diameters from a series of emmetropic eyes, and, according to him, an isopter is the line that connects those points on the retina at which the physiological point has the same size. The separate isopters are obtained by determining the limiting point on each meridian of the field of vision, where a black point of a determined size, when moved from the periphery to the centre, just begins to become visible. These limiting points are connected with one another by isopters which run almost parallel to the limits of the field of vision. If the physiological point just doubles from one isopter to another, they maintain among themselves very regular intervals. The examination of these points is of advantage in improving our sketches of the field of vision from the diagnostic stand-point.

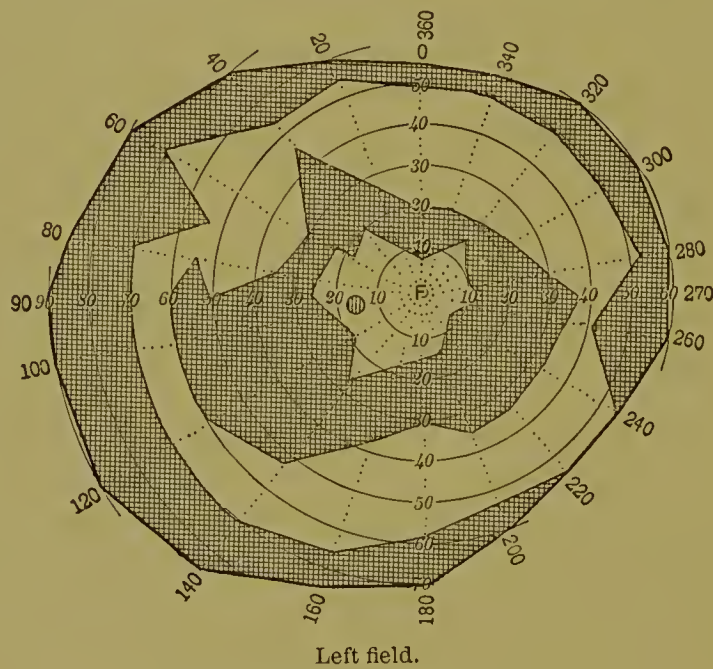
The method is as follows. A white card six degrees wide, with a black spot in its centre, is moved on Förster's perimeter from the periphery towards the point of fixation until the spot just becomes visible. The height of the card is made to correspond to the width of the perimeter, which is thirty millimetres wide. On the middle of its front surface is a black spot of a definite size. On the reverse side a strip of card-board is fastened in such a manner that it nowhere overlaps the card. This card is suspended from the arc of the perimeter, and is so arranged that it can be moved along the arc. The spots used are of a diameter of one-fourth, one-half, one, two, and four millimetres each, and, as they are exactly in the middle of the card, they must be three degrees distant from its border. This fact must be borne in mind when the registration of concentric circles is read.

The macular region may be alone diseased and show field-defects of different forms, extent, and intensity. Such defects are termed central scotomata. If all light-sensibility of the retina is lost in a central scotoma, the eye no longer has a central fixation-point. In such a case the nearest physiologically best formed point in the vicinity must be taken for a fixation-point. If the diseased eye has not acquired a squinting position, and if the other one is normal, the perimeter is placed in front of the eccentrically fixed eye in the usual manner, and the normal eye is left uncovered. The patient is then asked to fix his gaze on the spot on the perimeter. It will be then found that the diseased eye, through the sympathetic influence

---

<sup>1</sup> Ueber die Sehschärfe der Netzhautperipherie, Wiesbaden, 1892.

of the normal eye, takes the proper position. The sound eye can be then covered, and the examination continued as long as a proper position is maintained. By repeatedly removing the cover, and so regaining the proper position, a field of vision which exactly answers the physiological requirements can be obtained during the intervals. In a case where both eyes are eccentrically fixed, the patient can be asked to place his index finger on the fixation-point, and told to gaze at the spot where the tip of his index-finger touches. When all light-sensation has disappeared within such a central defect, it is spoken of as an *absolute central scotoma*. If the defect shows itself for one or all colors, and no defect is proved for the smallest white objects, it is known as a relative central scotoma. The terms indistinct and inaccurate central scotoma are used to signify that condition in which, although the color-impression prevails in the centre of the field of vision, its tint undergoes a modification.

FIG. 5.<sup>1</sup>

Besides this classification of absolute central scotomata, relative central scotomata, and indistinct central scotomata, central defects of field of vision may be divided after Förster's method into positive and negative central scotomata. In positive central scotomata the patient perceives a dark spot in the field in place of the fixation-point. Negative central scotomata are not recognized as scotomata, the patient perceiving a blurred and indistinct image. Central scotomata are also divided, according to their position in relation to the point of fixation, into pericentral scotomata, where the fixation-point lies in the centre of the scotoma, and paracentral

<sup>1</sup> In this, as well as in all following figures, the absolute defects are sketched double their natural size. The relative defects are sketched natural size; --- signifies the boundaries for blue; ... signifies the boundaries for red. In order to simplify the figures the boundaries for green have been omitted; — is the limit for white in functional nervous disturbance of sight.

scotomata, where the field lies on the edge of the scotoma. (*Vide* Fig. 5.) It is of great importance to observe whether these central scotomata appear on one or both sides, and if they are observed simultaneously in both eyes. Among the bilateral paracentral scotomata the temporal hemianopic and the homonymous hemianopic types play an important rôle, because the point of fixation remains intact. The first groups of central scotomata lie in the temporal half of the field of each eye outward from the fixation-point. The bilateral central scotomata may be either on the right or the left side of each eye, but are always on the same side of the point of fixation. A peculiar form is the central scotoma of fatigue, which is observed only in functionally nervous conditions.

Central scotomata may be produced by chorio-retinal changes in the macular region, and then they are mostly positive; or they may be produced by a disease of the papillo-macular bunch of fibres of the optic nerve, and then they are negative in character.

An affection of the papillo-macular bunch of fibres in the chiasm produces a double-sided temporal hemianopic scotoma. An isolated lesion of the papillo-macular fibres of a tract of the optic radiations and of the macular cortical field produces an homonymous hemianopic paracentral scotoma. The hemianopic paracentral scotoma also belongs to the negative group. Even if colored objects, on account of their feebler brightness, form a much more sensitive test for existing disturbances in the field of vision than white ones, yet they do not suffice if it is desired to determine the real extent of a central scotoma. The reason for this is that it is difficult to fix the exact limits of such scotomata, because the absolute types are generally surrounded by a zone of diminished sensibility, in which, for instance, a red square appears as dark red or brown through all varying shades from red to black. Again, the determination of colors depends upon a certain arbitrariness of the examiner and the patient, because it is placed at the option of both of them to decide which tint they still regard as red. To obviate this, the acuteness of vision for points is employed as a still more precise test. Especially is this so if in a case of diminished central acuteness of vision no central scotoma is found for the smallest colored objects, or if in a case with autopsy the field-defects can be compared with the microscopical preparations of the cross-section of the optic nerve. In this latter instance it is of importance to know where the function was missing in the field of vision, in order to determine the position of certain bunches of optic-nerve fibres.

The determination of the exact boundaries of a relative central scotoma always offers some difficulties, even to the experienced observer: still, it is easier for the patient to state if he sees a black point than to determine exactly the tint to which a color-object has turned.

In spite of the disturbing elements of the black points, it will be found that there is hardly any transition zone between the absolute defect of the field of vision and the healthy area. However, the existence of a zone of diminished sensibility can be proved by using points of different

sizes, finding for a large spot a central defect of less extent than for a smaller spot. A spot of one millimetre diameter is an extremely delicate test for a central scotoma, much more so than a red square of nine millimetres on a black background. The determination of point acuteness of vision is of the greatest prognostic importance, because the field sketched with black points gives in advance the form it will assume when disease has progressed. A central absolute scotoma may completely disappear, or it may change in the course of the treatment into a paracentral one and then remain stationary.

On the other hand, a paracentral scotoma, if it is not hemianopic, may change into a central one and increase in size. Again, a central scotoma, after having attained a certain size, may remain stationary without the periphery of the field being altered in any particular. This also applies to hemianopic scotomata, but with the modification that either the extension or the contraction of the scotomata remains limited to the half of the field in which the scotomata are found.

An important place in the field of vision is the blind or Mariotte's spot. Its position and extent correspond with the situation and size of the optic disk. This area is termed the "blind spot" because in this situation the fibres of the optic nerve cannot be affected directly, and hence the patient receives no light-sensation at this point. Its form is, according to von Helmholtz,<sup>1</sup> that of an irregular ellipse with short projections representing the beginnings and endings of the retinal arteries and veins.

As the point of entrance of the optic nerve lies somewhat inward and upward from the fovea centralis, the blind spot is found somewhat outward and downward. Usually it is situated between the tenth and twentieth concentric circles on the perimeter. Landolt<sup>2</sup> and Dobrowolsky<sup>3</sup> have determined the distance between the optic disk and the macula lutea. In emmetropia they say it is 3.915 millimetres. In hypermetropia it is somewhat greater, but in eyes of a moderate degree of myopia it is slightly less; in pronounced myopic eyes it is much greater.

The area of the blind spot is determined by means of the point method of examination. During such a procedure the peculiar fact which agrees with the discovery of Bjerrum can be noted, that the defect for a small spot (0.5 millimetre in diameter) extends one degree farther than for a larger one, showing that the absolute defect is surrounded by a circular relative one.

Under certain pathological conditions, when the perceptive elements of the retina in the vicinity of the optic disk become pressed upon or undergo atrophic changes, there is an enlargement of the blind spot: for example, in choked disk and peripapillary chorio-retinitis. The same result occurs congenitally when macillary fibres of the optic nerve run

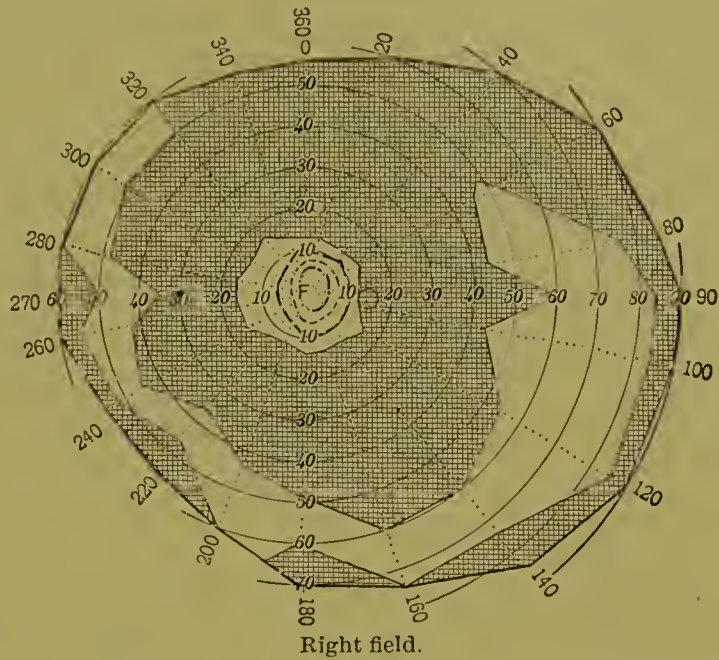
<sup>1</sup> Physiologische Optik, ii. Aufl., S. 253.

<sup>2</sup> Centralblatt für die Medicinischen Wissenschaften, xlv., 1871.

<sup>3</sup> Klinische Monatsblätter für Augenheilkunde, 1871, S. 437.

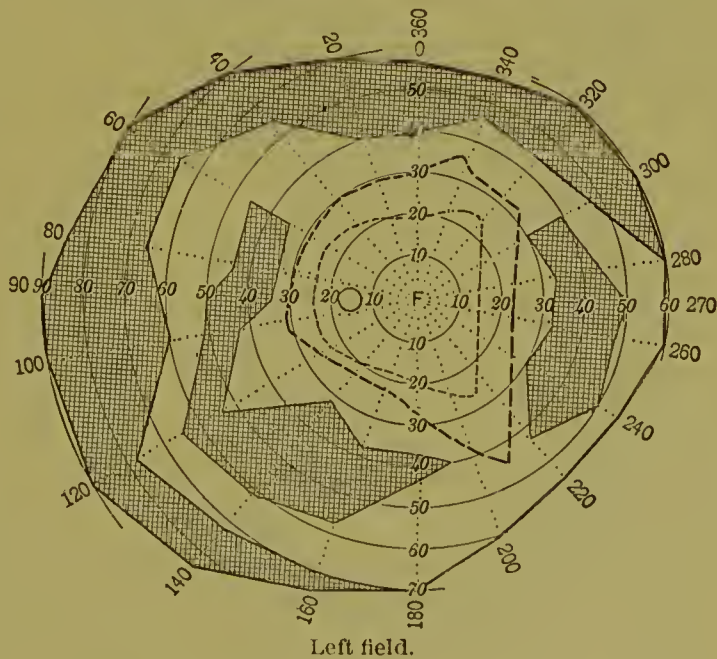
for a greater or less distance into the retina. In congenital coloboma, which always lies downward, the blind spot shows an upward enlargement. It may be enlarged by the formation of new connective-tissue bands on the optic papilla.

FIG. 6.



That part of the field which lies between the fifteenth and forty-fifth concentric circles is termed the intermediate zone. This zone also shows peculiar pathological defects. A peculiar manifestation is the so-called ring

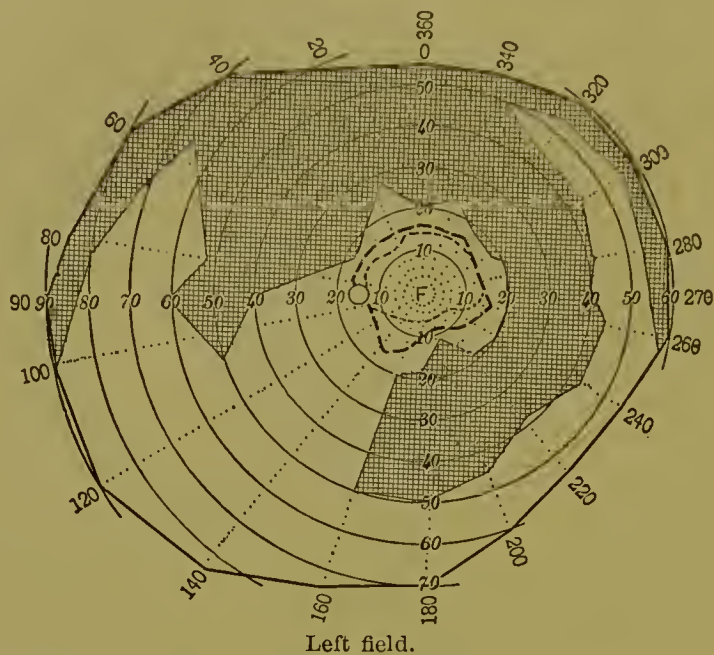
FIG. 7.



scotoma,—*i.e.*, a defect which surrounds the healthy macular part like a ring. This circular defect is of a gradually increasing breadth, and is partly or wholly surrounded by the remaining healthy peripheral part of the field of vision. (See Fig. 5.)

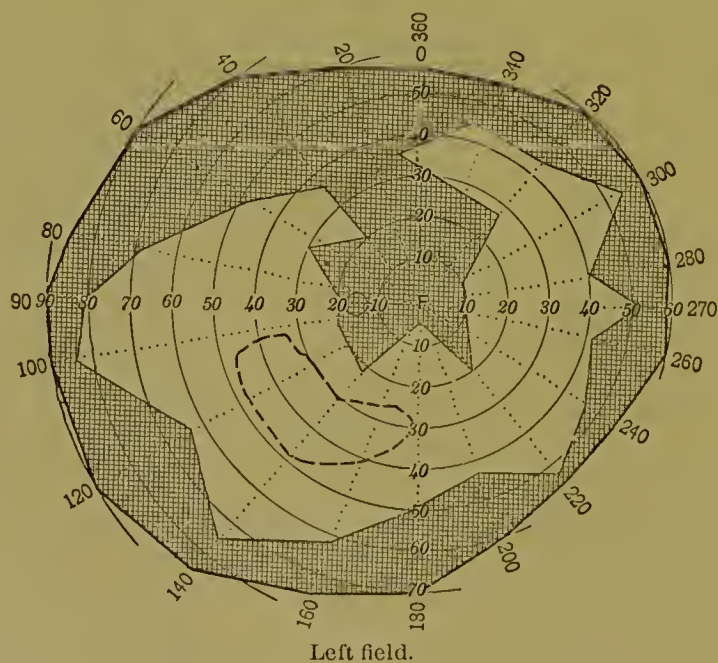
Sometimes the remaining macular part is surrounded by a semicircle (as in Fig. 6). The scotoma begins with one or several so-called zonular insular defects (at least in cases of chorio-retinitis luetica) (Fig. 7), which in advancing press against one another until the ring scotoma is formed.

FIG. 8.



Sometimes during the development of ring scotomata semilunar forms which reach—in one part, at least—the periphery of the field can be seen. (See Fig. 8.) In retinitis pigmentosa, in which ring scotomata are some-

FIG. 9.

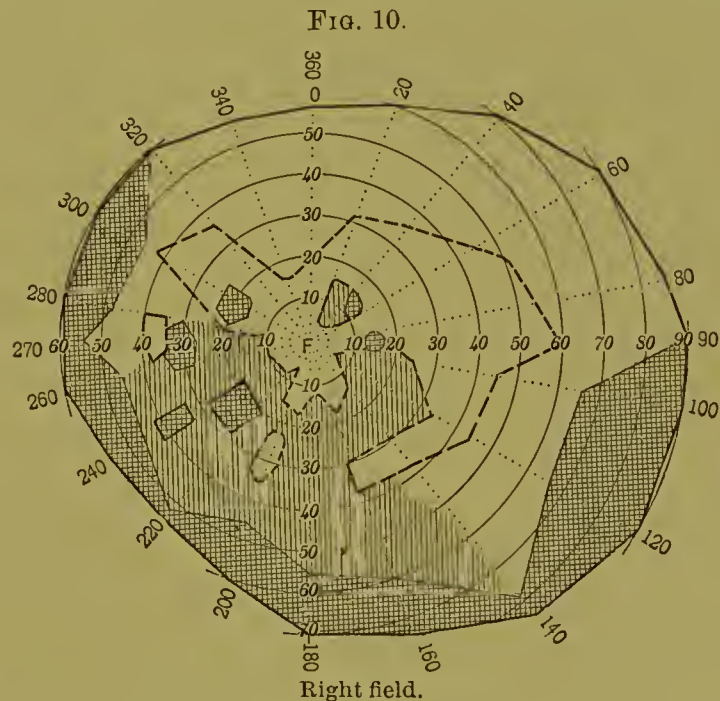


times found, the periphery and the macular part alone remain. In such cases the color-field is contracted, existing only in those portions which are connected with the fixation-point.



In syphilitic chorioiditis the closed-ring scotomata change during treatment into zonular defects, which gradually disappear. They are occasionally observed in multiple sclerosis of the optic nerve resulting from various forms of inflammation. A small ring-scotoma of this character has been observed and sketched by Uthhoff.<sup>1</sup> In certain forms of optic-nerve atrophy, absolute central scotomata commencing near a peripherally concentrically contracted field, so that only the intermediate zone of the field of vision remains, are found. (See Fig. 9.) Within this retained region color-perception is limited to islands of blue. By eccentric growth of the central scotomata and by the increasing concentric contraction of the field, the remaining zone is divided into two parts, one lying inward and the other outward. Finally, these remaining parts gradually disappear, and blindness ensues. These defects are nearly always bilateral.

If a number of small and large insular scotomata lie dispersed over



the field of vision, we term the condition a cribriform field of vision, or *visus reticulatus*. These small scotomata usually occur in the intermediate part of the field, and near them vast peripheral zonular defects are often found. (See Fig. 10.) This cribriform field is frequently seen in grave cases of chorioiditis disseminata where the chorioidal disease has invaded the layer of rods and cones and caused them to undergo atrophy. We see how the upper and lower damaged borders of the field for blue (Fig. 10) indicate the gravity of the lowered visual power.

That portion of the field of vision which lies outside of the forty-fifth concentric circle is called the peripheral zone. Peripheral insular defects disturb the vision but slightly, especially if they lie far from the point of fixation, and become manifest only when the field is examined.

<sup>1</sup> Archiv für Psychiatrie, xxi.

Greatly contracted fields cause the patients to feel as if they were looking through a tube. They are therefore compelled to turn their eyes in all directions in order to orient themselves, and even then they find it necessary to make use of their memories. Defects in the inferior portion of the fields cause the patients to stumble over objects whilst looking straight ahead. This peculiarity of the eyes, with the tapping gait, in these two types of cases, gives a characteristic appearance of helplessness.

The degree of acuteness of vision of the periphery of the retina is quite small. It is not constructed for perceiving distinct forms, but only to call attention to points and surfaces as contrasted with their surroundings, the real conditions of which are perceived by directing the eyes to such points and surfaces, this being assisted by the increased sensibility of the periphery for moving objects. The faculty of the periphery of the retina for perceiving forms is never made use of in physiological conditions, and is therefore so slightly developed that exact examinations appear uncertain; but this uncertainty is neutralized by the fact that a certain amount of physiological perfection may at times be obtained, especially if central sight is lost.

The peripheral zone generally begins where the perception of a five-millimetre-square blue object ceases.

An image projected from the periphery of the retina of a centrally fixing eye is very dim, because the cone of rays falling laterally into the pupil is smaller than the cone that comes from the point of fixation.

Förster<sup>1</sup> states that the rays of the sun may fall into the eyes for several seconds at an angle of forty-five degrees to the visual axis without producing or leaving any vivid impressions. Besides, the greater the angle at which the light falls upon the eye the greater will be the loss to the lateral parts of the retina by reflection from the cornea and the lens. From the fixed relation between the amount of light- and color-perception it follows that the farther we pass from the centre of vision the less light will fall upon the retina and the less perfectly will any colored test-objects be recognized. Finally, there is a stage at which all colors give the sensation of their having been mixed with black and white. This is the reason why test-objects of all colors, while passing from the periphery to the point of fixation, appear in other shades and tints before being properly recognized. These transitions from the light to the saturated impression of the color take place gradually, so that a certain arbitrariness cannot be avoided in determining the values on the perimeter for the limits of different colors, and hence no agreement has been reached in regard to the boundaries for color-fields. Yellow has the greatest extent, then blue; red and green have the smallest extent. From the fact that individuals with normal eyes are differently endowed for the perception of color, it follows that color-fields cannot be the same in different subjects under equal conditions.

---

<sup>1</sup> Hemeralopia, Breslau, 1857, S. 30.

Women have a more pronounced faculty for distinguishing color, and consequently have a larger color-field. The result of the examination of color-fields depends upon the following conditions, under which every examination is made: (1) the saturation of the color; (2) the size of the object,—*i.e.*, the magnitude of the visual angle; (3) the illumination of the object; and (4) the background (because of simultaneous contrast).

Although we find a rather broad and apparently color-blind zone between the limit of the field for white and the peripheral limit for a blue of twenty-five square millimetres, still the periphery of the retina in its normal condition is said not to be color-blind. Donders and Landolt<sup>1</sup> have shown that the sensibility of the peripheral zone of the retina for colors would be the same as that of the centre if the intensity of the light were proportionally increased.

We must use clean colored objects, and only with the strongest daylight. The colors must be kept in a dark place, as the pigments are changed by the action of light.

Aubert has shown that when the eye is centrally fixed, the peripheral zone of the retina becomes fatigued more quickly by color-sensations than the central regions; and, further, that the peripheral zone of the retina is more easily fatigued by a colored object than by a white one fixed on the periphery of the perimeter. For this reason, and because of the greater sensibility of the retina for moving colored objects, it is advisable to make trembling movements with the test-object during the determination of peripheral boundaries.

In order to have uniformity of pigments in perimetric examinations, it has been agreed upon to use the so-called Heidelberg flower-paper. If it is desired to compare the extent of the color-field with the limits for white, the same-sized objects must be used. Strong diffuse daylight should always be employed.

As the quantitative sensibility for colors is greater in the adapted than in the non-adapted eye (Aubert), the organ must repose before the examination of the colored fields of vision. The relation of the limits of color to the limit of the field of vision for white is of the greatest importance, inasmuch as the limit of vision for colors recedes from the limit of the field of vision for white in the order blue, red, and green, under the following conditions: in all atrophic conditions of the optic nerve and of the chiasm, and in all morbid processes resulting in pressure upon the visual fibres in the optic tract and the cerebrum.

The distance between the limit for blue and that for white becoming greater, the size of all color-fields becomes smaller. The relation of the color-limits can be compared with the extreme limit of the field of vision for white only when the latter has been determined with an object of the

---

<sup>1</sup> Ophthalmological Congress of Heidelberg, 1873; *Klinische Monatsblätter für Augenheilkunde*, 1873.

darkest gray, which in full daylight is still distinguished as "bright" until the limit of the normal visual field is reached.

The limits of the field of vision of a normal eye will still be found normal for a white test-object of five millimetres even in a darkened room. Hence it is of no consequence, in the case of a normal eye, whether the boundaries for white be determined in such a room, or in full daylight with a gray object which is in brightness equal to the white object used in that dim light.

In regard to color-limits, the normal eye furnishes quite different results. If they are determined by the subdued light in which the field for white still proves normal, the color-field will be found to have undergone a marked degree of concentric contraction. But by using a gray test-object in strong daylight, the several fields of vision for color are obtained with their respective normal limits.

Landolt<sup>1</sup> has proved that small blue objects in subdued light are perceived by the normal eye more distinctly in the peripheral zone than in the central one, whereas red objects are perceived more distinctly in the central zone,—*i.e.*, the reverse of the arrangement that is found when the tests are made during strong daylight.

The relation between the color and white limits is of diagnostic importance. If the sensibility of the retina, or, what is the same thing, the conducting ability of the optic cross-section, be assumed to be equally diminished until the white test-object in full daylight just reaches the limit of the normal field of vision, the color-limits will prove to be more concentrically contracted. This is accounted for by the fact that the sensibility of the eye for colored test-objects is much less than that for the same-sized white test-objects. In cases in which the color-limits are contracted and central acuteness of vision is diminished, even though a normal or a slightly contracted limit for white exists, the condition is a pathological one in which progressive atrophy of the optic nerve may exist.

There are three different pathological states in which the determination of the field of vision in full daylight shows normal or almost normal limits for white and a great reduction in its limits for colors: (1) idiopathic hemeralopia; (2) the early stage of progressive atrophy of the optic nerve; (3) the purely functional nervous disturbances of vision.

In hemeralopia the field for white is increasingly contracted by the gradual diminution of light. Color-limits contracted in daylight are perceived only at the point of fixation, and soon vanish as darkness is increased. Fig. 11 shows the field of vision of the left eye of a twenty-year-old man suffering from idiopathic hemeralopia. The examination was made by daylight. The right eye exhibited an analogous condition. Central visual acuteness in full daylight equalled  $\frac{6}{9}$ . In the sketch a slight concentric contraction for white and a considerable one for color can be

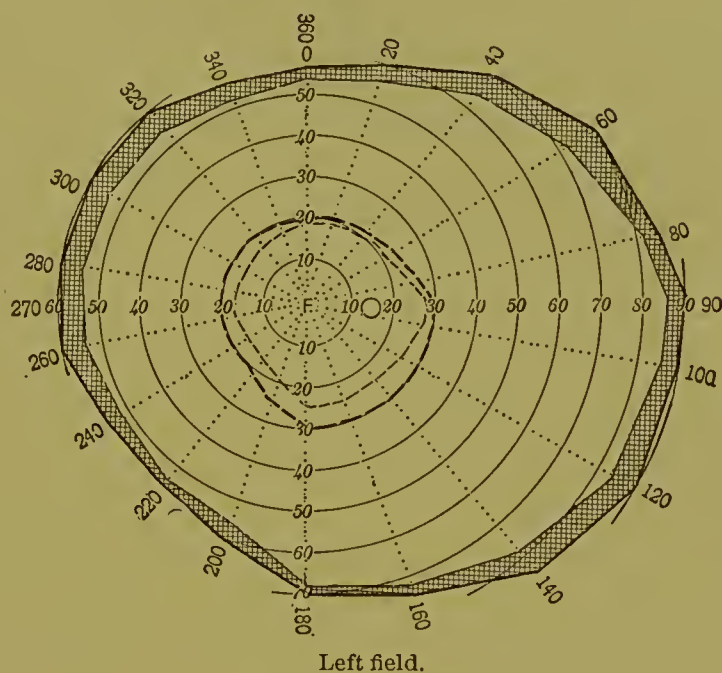
---

<sup>1</sup> Graefe und Saemisch, *Handbuch der gesammten Augenheilkunde*, ii. S. 535.

noticed. When the light was diminished in this case, my own visual acuteness still equalling  $\frac{6}{6}$ , all color had disappeared from his field of vision, and his field for white (obtained with a five-millimetres square of color) became contracted to almost the size of the red field shown in Fig. 11.<sup>1</sup> The ophthalmoscopic appearances were negative. This patient could not perceive large objects indirectly in a slightly darkened room, and his orientation was diminished.

In symptomatic hemeralopia the field of vision is contracted in diminished light in its whole extent or in single zones according to the extent

FIG. 11.



of the disturbed portion of the retina. Zonular defects and ring scotoma can be demonstrated by either gray test-objects in daylight or white test-objects in a diminished light. Figs. 5 and 6 are sketched from fields taken in this manner.

According to Bjerrum,<sup>2</sup> certain chorio-retinitic processes have proved to be hemeralopic in type; for example, retinitis pigmentosa, chorio-retinitis syphilitica, and chorioiditis disseminata. The following conditions also give hemeralopic fields: high-grade myopia, senile eyes, and glaucoma that has developed from chorioiditic conditions. Förster<sup>3</sup> has found more or less extensive central scotomata in symptomatic hemeralopia caused by dazzling light, especially if the macular region is affected. The hemeralopia is explained by the tardy recovery of the retina in a dark room,—*i.e.*, by the slow reproduction of the substance of the nervous retinal elements

<sup>1</sup> The mode of expressing the color by the character of the line used is that which has been agreed upon by all scientific observers, thus avoiding the constant repetition of initial letters or words denominating the color used.

<sup>2</sup> Archiv für Ophthalmologie, xxx. 2.

<sup>3</sup> Loco citato.

which are decomposed by the action of light. Mention must be made here of the condition known as the non-adapted eye (adaptation as understood by Aubert). Treitel<sup>1</sup> has proved experimentally that the non-adapted eye, after looking for three minutes upon a snow-covered surface and then entering a darkened room, could for some time perceive objects only indirectly, everything centrally placed appearing black. The external limit of the non-adapted eye, when using a white (twenty millimetres square) color, was found to diminish according to the degree of darkness, the limit being contracted to the point of fixation when the darkness was marked. The external limit of the adapted (recovered) eye remains unchanged, even under a marked degree of darkness, this result being in contrast with that for the color-fields, which are more or less contracted according to the degree of darkness.<sup>2</sup>

Treitel<sup>3</sup> is convinced that when a non-adapted eye is examined in daylight with a gray test-object so that the field just shows normal limits, it will be contracted when the examination is made with the same object in a waning light. Landolt<sup>4</sup> has stated that during recovery the first tint to be perceived properly is green, followed by yellow, red, and blue.

In pure (*i.e.*, not hemeralopic) amblyopia, Treitel could not find any further contraction of the limits of the visual field when the illumination was diminished. In regard to the central visual acuteness, Bjerrum has found (confirmed by Treitel) that with diminished illumination the lessening of the field in amblyopic eyes which are not hemeralopic is much less in comparison with normal eyes than when they are examined by daylight.

Concentric contraction of the field of vision for white, with a reduction of the color-area, is pathognomonic of disturbance resulting from neurosis. Here can be found, as proved on Förster's photometer, a slow adaptation as compared with the normal eye.

The normal eye perceives the lines on Förster's diagram through an opening of the diaphragm of two millimetres square after one and a half or two minutes' exposure, while in the diseased condition this result can be obtained only after ten or fifteen minutes' time, according to the gravity of the case and the high degree of contraction of the field, as sometimes seen in hysterical women, in whose cases a half-hour may elapse before it can be accomplished.

In contrast to hemeralopics, patients suffering from purely functional nervous disturbances of sight are nyctalopic. If such patients are examined after adaptation (as Aubert understands the term) has taken place, the field of vision will be found to be either normal or considerably enlarged.

The pathological appearances of the fields of vision of such patients are also explained by the slowness of the recovering processes of the retina in

<sup>1</sup> Archiv für Ophthalmologie, xxxiii. 2, 97.

<sup>2</sup> Wolfberg, Archiv für Ophthalmologie, xxxi. 1, and xxxiii. 1.

<sup>3</sup> Archiv für Ophthalmologie, xxxi. 1, xxxiv. 3, and xxxvii. 2.

<sup>4</sup> Aubert, Graefe und Saemisch, Handbuch der gesammten Augenheilkunde, ii. 535.

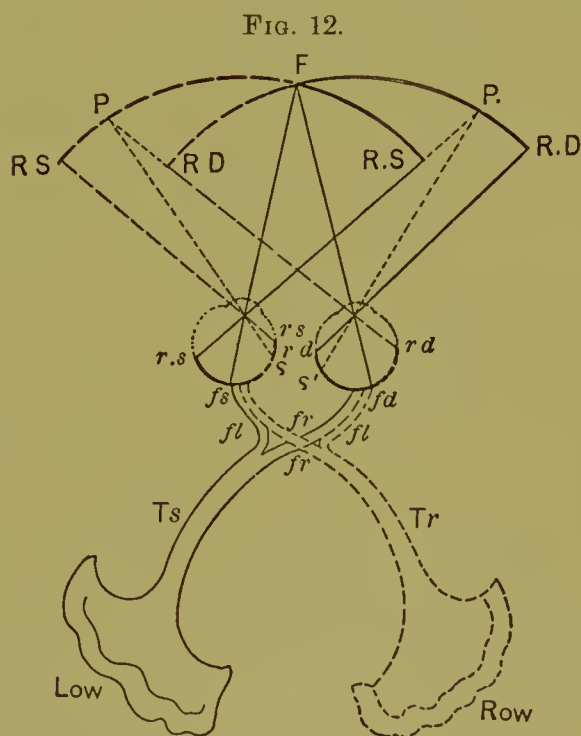
darkness; either because the blood of such patients furnishes a much less useful material for the rapid recovery of the visual substance that has been decomposed by the action of light than in normal eyes, or because the slow recovery of the decomposed substance depends upon centrifugally conducting nerves in the optic tract.

In regard to the varieties of defects of the peripheral zone of the visual field, three forms can be distinguished: (1) General equally concentric contraction. (2) General concentric contraction with sector-like defects. (3) Peripheral zonular, or sector-like, or plane-like defects extending from a certain point on the periphery more or less closely to the point of fixation, while the remaining portion appears almost, if not quite, normal.

If the defect is absolute, all light-sensation disappears out of the area. To determine the limits of such defect it is necessary to employ intensely bright objects. Moreover, all the surrounding or neighboring scotomata show areas which are in direct proportion to the size of the object used. In all this work the size and brilliancy of the object employed should be noted.

The relation of the defects of the field of vision to the vertical meridian makes the position of the field very important. The vertical meridian divides the eye into a smaller nasal and a larger temporal portion. The proportion of the latter to the former is from two-thirds to one-third.

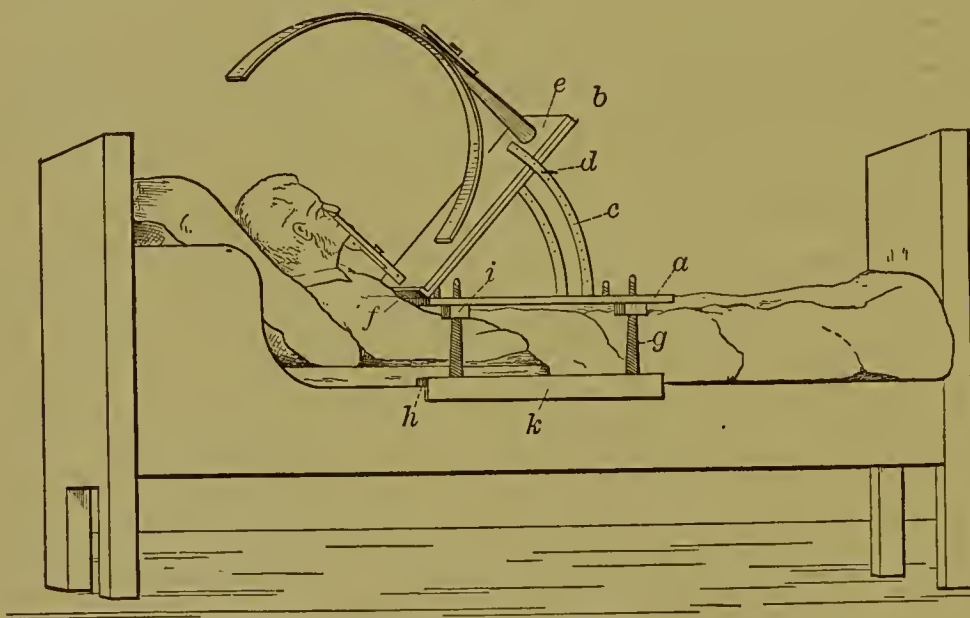
The course of the optic nerves is so arranged that those parts of the retina of each eye, *rs* to *fs* and *rd* to *fd*, which lie on the left side of the fovea centralis *fs* and *fd* (Fig. 12) are connected with the left optic centre of perception *Low* in the left hemisphere, so that the nerve-fibres of the nasal part of the retina, *rd* to *fd*, of the right eye run to the optic tract of the left side, *Ts*, as a crossed fasciculus through the chiasm. The temporal part of the left retina, *rs* to *fs*, of the left eye, however, sends nerves as a lateral or uncrossed fasciculus into the optic tract of the same side, *Ts*. Consequently the temporal portions of the retina of each eye are connected with the optic centre of their respective side, and the nasal portions with the optic centre of the opposite hemisphere. If the right visual centre *Row*, or the corresponding nerve-tract, *Tr*, is destroyed, those parts of the retina, *fs* to *rs* and *fd* to *rd*, which lie on the right side of the two foveas *fs* and *fd* will have their function destroyed, while the related parts of the fields of vision will become defective.



As that part of the retina lying nasally from the fovea centralis is almost twice as large as that lying temporally, so the surface of the temporal portion of the visual field is almost twice as large as the nasal surface of the same. The dividing line of the two parts of the field lies nearly always in the vertical meridian, or at least runs quite near it. As the fibres coming from the nasal parts of the retina cross one another in the chiasm, and as the fibres coming from the temporal parts of the retina do not cross before uniting with the optic fibres coming from the nasal part of the opposite retina, so morbid processes which meet the chiasm in the direction *fr fr* (Fig. 12) or the tracts *Ts*, *Tr*, or farther back, must produce field defects which lie at corresponding places laterally from the vertical meridian. If the chiasm is destroyed in the position *fr* or *fr* (Fig. 12), a bitemporal defect in the field of vision occurs, showing functional interruption of the nasal sides of the two retinae.

As it often happens that bedridden patients must be examined while lying down, the author has constructed an apparatus which he terms a *bed-perimeter*. (Fig. 13.) A wooden board (*a*), the breadth of which is

FIG. 13.



Wilbrand's bed-perimeter.

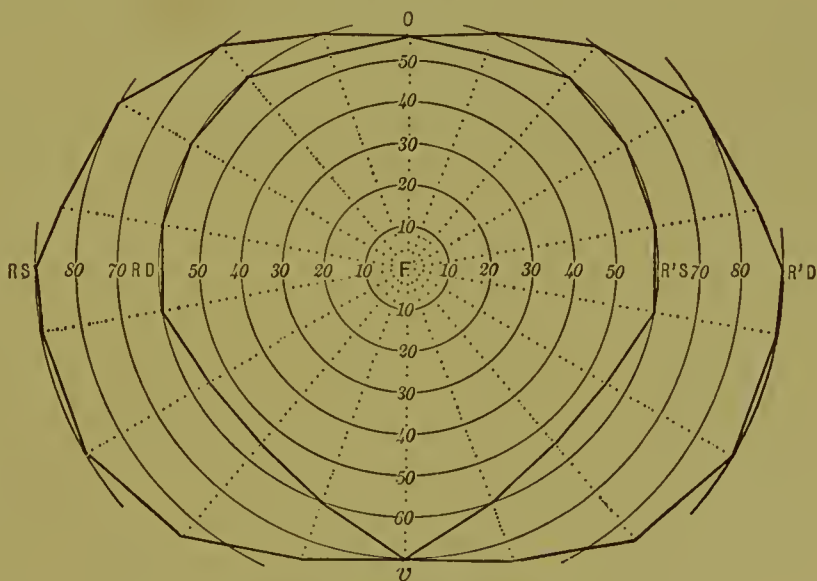
equal to the length of the perimeter, and the length of which equals the width of the bed, is made so that it can be raised or lowered like a reading-desk. A second board (*b*), which can be placed at any degree of inclination upon two perforated irons (*c*), is supported by putting a little iron pin (*d*) into a series of holes. Upon the board *b* is placed the perimeter. The board *b* is connected with the board *a*, on the side turned towards the patient, by means of two hinges, which are placed near the corners. Both boards between the hinges are hollowed out so as to fit the regions of the chest and abdomen. The perimeter itself is supported below by a clamp (*f*), which is fixed vertically to *b*. The board *a* is supported by four wooden screws (*g*), which are fastened by pairs to a rather narrow board (*h*) resting hori-



zontally on the lateral bed-boards. On the board *h*, near the outer end, is placed a clamp (*k*), so as to prevent the whole apparatus from moving sideways. A head-rest is so arranged that the chin of the patient can be brought into a comfortable position on the chin-rest of the instrument.<sup>1</sup>

*The Binocular Field of Vision.*—As patients nearly always judge their visual defects binocularly, we must also consider the binocular field of vision. Inasmuch as under normal conditions of the eye-muscles the lines of sight of both eyes cross each other at *F* (Fig. 14), the vertical meridian running through *F* is common to both. The nasal portion of the field *O—RD—v* of the right eye takes its place in the temporal part of the field of vision *O—RS—v* of the left eye; the field of the right eye alone being *O—R'D—v—RD—O*. The nasal portion of the field of the left eye, whose monocular part is represented by *O—RS—v—R'S—O*, is likewise analogous. Both nasal parts of the field meet in the vertical meridian, and to a certain extent they form a smaller field of the size *O—RD—v—R'S—O*. To this the binocular field of vision adds the temporal portions of the fields of both eyes. If the optic chiasm (Fig. 12) is destroyed in the direction *fr fr*, then both temporal parts of the visual field will be missing, and (Fig. 14) consist of the two remaining

FIG. 14.



Binocular fields of vision.

nasal portions alone. Fig. 12 shows that all that lies in the binocular field of vision on the left side from *F* and the vertical meridian respectively is perceived by the right optic centre, and all that lies on the right side from *F* is seen by the left optic centre.

Through experiments, especially those of v. Gudden, it has been determined that the uncrossed fibres of the optic nerves (Fig. 12, *fl*) increase in thickness with the size of the binocular field of vision. In the lower vertebrates a total crossing of the optic nerves takes place, because their eyes are

<sup>1</sup> This apparatus can be obtained from John Plumbeck, of Hamburg, Germany.

placed so far to the sides of the head that an object cannot be seen simultaneously with the two organs. In higher mammals—for example, the dog—the eyes are moved farther to the front, and consequently objects lying straight in front and near the prolongation of the median line of the body are seen by both eyes at the same time, so that in this animal a small binocular field of vision is formed. Here the fovea centralis lies entirely in the nasal portion of the retina. In the human species both eyes lie in the frontal plane, so that the binocular visual fields fall upon one another and in consequence have a common fixation-point.

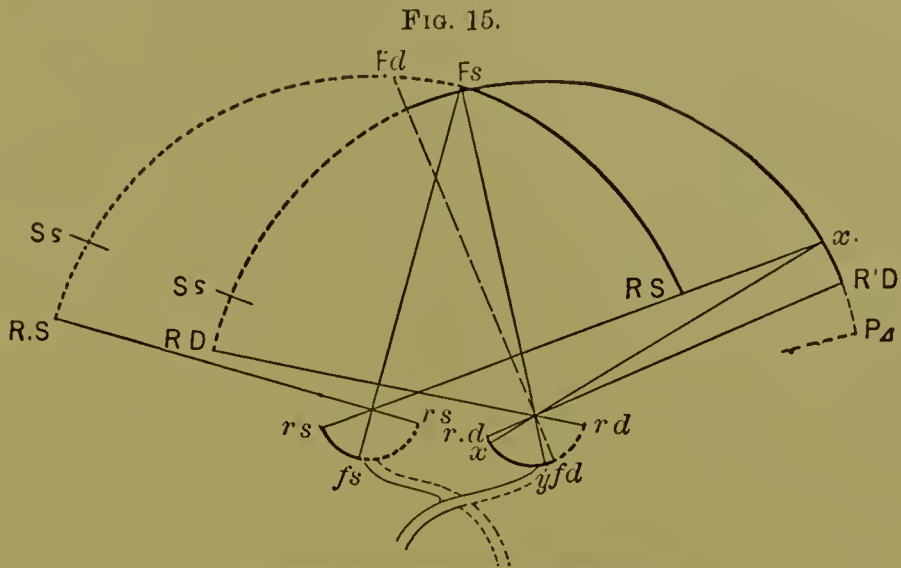
In the binocular field of vision Mariotte's spot cannot be determined experimentally, lying as it does on the right and left sides of the field in each temporal portion. Moreover, in the common field of vision the corresponding parts of the nasal halves adjust the light-sensation for their respective places. The monocular defects lying in the region of the common field ( $O - RD - v - R'S - O$ , Fig. 14) may therefore disappear in the binocular field of vision, provided that those parts which cover one another remain normal in each eye.

In disturbances of the binocular fixation the extent of the binocular field of vision undergoes certain modifications.

If the binocular field of vision of a squinting person be measured, its lateral extent will not correspond with the size of the temporal parts of the fields of both eyes, this being dependent upon the relation of the eyes to each other. In pronounced cases of convergent strabismus the field of the squinting eye will lie (if the resulting position be considered) almost entirely in the field of the non-converging eye.

In Fig. 15, which represents convergent strabismus with a squinting right eye, the limit of the binocular field of vision, which should, in normal binocular fixation, lie towards the right in  $P\Delta$ , lies in  $R'D$  just as long as the right eye ( $r.d - rd$ ) is squinting inward. The image of the fixed object  $Fs$  falling on the part of the right retina  $y$  lies inward from the fovea  $fd'$ . That part of the cortical visual centre which belongs to the region  $y$  of the retina gradually acquires the habit of suppressing the perceived images (regional exclusion) in the interest of simple binocular sight, because, through divergence of the eye, it becomes necessary to divert the attention from the image of the squinting eye and direct it upon that of the fixing one. However, as the exclusion of images by the squinting eye is practised only to avoid double vision, the habit is applied to such objects alone as project their images into both eyes,—that is to say, to those images which are in the common part of the field of vision. If the object advances into that part of the temporal half of the field of the squinting eye where it can no longer be seen by the other eye (Fig. 15,  $x - R'D$ ), then the image is no longer suppressed in the squinting eye. The extent of the binocular field of vision in moderate degrees of convergent strabismus is practically somewhat less than that of the non-squinting eye. That part of the retina in which no suppression of the image takes place remains in constant prae-

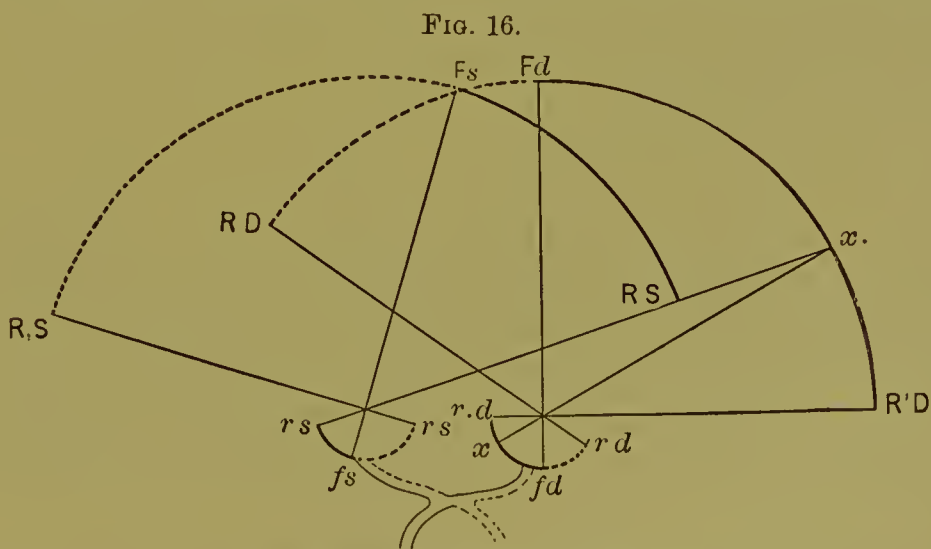
tice, and in consequence retains a fair visual power, while other portions of the retina gradually lessen their sensibility.



Visual field in convergent strabismus.

It can be easily seen from Fig. 16 that the binocular field of vision increases in divergent strabismus. The exclusion of the images of the squinting eye in the region of the common field of vision must be regarded as a process occurring outside of the sphere of pure sensory activity.

In monocular squint a congenital amblyopia, in which the visual acuteness is reduced to the ability to see to count fingers, is often found. In this form the ophthalmoscopic appearances are normal, and color-sensibility for small objects is retained. Usually, without any trace of a central sco-



Visual field in divergent strabismus.

toma, the visual acuteness of the fovea centralis is so slightly different from the perimacular region that the eyes oscillate in order to find a suitable retinal spot for a fixation-point. From this circumstance the conclusion is arrived at that under such conditions the physiologically favored macula lutea from birth equals or approaches in functional value that of the sur-

rounding retinal zones. This supposition is further substantiated by the fact that, like the peripheral retinal regions of the normal eye, during continued fixation, the images rapidly become confused and disappear. On account of these facts it can readily be understood that under such circumstances perimetry must be difficult.

A definite criterion for amblyopia exanopsia is not yet possessed. A differential diagnosis can be arrived at only by exclusion. Groenouw has been able to prove, by means of observations upon the acuteness of vision for points, that in one case the amblyopia was caused by a defect of the visual centre, and has shown that peripheral sight was normal. In his case the isopter in the immediate neighborhood of the point of fixation (the isopter found for an object point of a quarter of a millimetre) extended in the sound eye nearly half a degree farther towards the periphery than in the amblyopic eye.

Cases of congenital amblyopia in which the fixation is normal must have their fields of vision studied with diminished illumination in order to make a differential diagnosis between them and a coexistent hemeralopia. In congenital amblyopia the functional disturbance always affects the macula lutea and the temporal portion of the retina in preference to the nasal part of the retina, which functions wholly or incompletely.

As a rule, the non-suppressed monocular part of the field of the squinting eye is not projected in the direction of the outer world, which it should be in accordance with the law of identity. That is to say, it is not projected in a direction which is in opposition to the diverging eye, but directly joins the field of vision of the other eye. This is probably explained by the experience through which the squinting subject finally acquires an idea of the divergence of the eye, and by which he is taught to correct the deviation by a changed projection.

## SPECIAL PART.

In order better to understand the significance of the visual fields in the diagnosis of disturbances in the visual apparatus, it seems best to make the following divisions: 1, the orbital portions (consisting of retina, optic papilla, and chorioid); 2, the optic nerves; 3, the optic chiasms; 4, the optic tracts; 5, the primary optic centres; 6, the intra-cerebral tracts leading to the cortical centres; and, 7, the visual centres in the cortex of the brain.

### I.

#### THE VISUAL FIELD IN DISEASES OF THE RETINA AND CHORIOID.

As the outer layers of the retina are chiefly nourished from the chorioidal capillaries, we often find a pathological change in the outer layers of the retina as a consequence of disease of the chorioid. It is also found that in diseased conditions of the chorioid the contiguous patches of the outer layer

of the retina in contact become involved, presenting differences from diseases of the inner layers of the retina. Although in diseases of the inner retinal layers (changes in the retinal vessels, hemorrhages, œdema, sclerosis of the nerve-fibres, fatty degeneration, etc.) we usually find only a certain degree of amblyopia, without any characteristic defect of the visual field, yet in affections of the outer layers of the retina scotomata soon appear in patches where the nourishment of the delicate structures is altered by the disease-processes. At their commencement these patches can, as a rule, be demonstrated only by perimetry with diminished light.

In order to make as clear as possible the general symptomatology of diseases of the optic disk and inner layers of the retina (the nerve-fibre layers of the retina) in contradistinction to that of the outer retinal layers (epithelial nerve-layers), as well as the chorioid (as affected in chorioido-retinitis), the author has compiled the following table :

TABLE I.

## GENERAL SYMPTOMATOLOGY.

Diseases of the optic nerve, optic papilla, and innermost layers of the retina.	Diseases of the outer layers of the retina and of the chorioid (retino-chorioiditis).
---	---

*Perception of Light.*

Dark objects on a white ground picked out as well or almost as well as with healthy eyes.	Torpor retinae.
---	-----------------

*Field of Vision by Diminished Light.*

The eye acts as a sound one, and shows the same faults as by ordinary daylight illumination.	By diminished light the field of vision shows either concentric diminutions, zonular defects, or central scotomata, while in these cases by full daylight no defects can be found, or by diminished light the small defects that are obtained by full daylight will appear increased and more intense.
--	--

*Form of the Defects of the Field of Vision.*

Mostly concentric limitation with sector-shaped re-entering angles. The field of color-perception is diminished as compared with that for perception of white. Central scotomata with diminution of the field of vision on one side are present.	Large irregular defects with zones and islands (visus reticulatus). Circular scotomata.
--	---

*Nature of the Scotomata.*

Central and peripheral negative scotomata which are not recognizable, but in which objects are not ordinarily recognized.	Central and peripheral scotomata are positive, being recognized as dark spots.
---	--

*Central Visual Acuteness.*

Usually better by diminished illumination; nyctalopia exists.	Usually diminished by diminished illumination; hemeralopia exists.
---	--

TABLE I.—(Continued.)

*Perception of Color.*

<p>Typical disappearance of color from the visual field: green goes first, then red, and lastly blue. Zones of dulled perception to color (color-blindness) to absolute loss of power of perception of color. In partial optic atrophy the fields of white- and color-perception approximate towards the point of disease.</p>	<p>In ordinary daylight, concentrically limited field boundaries. In clear, full daylight the colors appear in the diseased areas just as they do by diminished light to the normal eye. In the disturbed portion of the field, green appears bluish, yellow appears reddish, and violet appears as gray.</p>
--	---

*Metamorphopsia (Retinal).*

Not present.

Common.

## CONGENITAL ANOMALIES.

*Medullated Nerve-Fibres.*—Here there is an irregular enlargement of the blind spot, the expansion corresponding to the direction of the extent of the anomaly. In some cases where the medullation is not opaque it is not possible to demonstrate any increase in the blind spot.

*Retinal and Chorioidal Colobomata.*—The exact size of colobomata of the *retinal* tunie can be established only by the perimeter. It is in this not sufficient simply to discover the presence of a defect in the field of vision by means of the white examining object, for there might be a relative defect due to a congenital disease of the chorioid, with participation of the corresponding portion of the retina, because it is absolutely necessary that in the retinal colobomata no perception of the most intense light exists.

For this reason Lindsay Johnson<sup>1</sup> has had a small electric lamp constructed, so that by means of a lens all the rays are made parallel. This can be used as an examining object in the sliding apparatus of Förster's perimeter. By this means the deficiency of each and every perception of light over the region of the coloboma may be obtained, and thus the actual size of the defect demonstrated by the perimeter. Retinal colobomata situated below the papilla cause corresponding defects in the upper part of the field of vision. Such defects may extend into the field towards the blind spot. (Fig. 17.) The field-defect often does not correspond in size with the chorioidal colobomata as seen with the ophthalmoscope. The reason for this is that the portions of the retina lying near or in contact with the coloboma of the chorioid are only more or less disturbed in their development. In consequence it is the retinal defect alone that corresponds to the visual defect, as demonstrated by the perimetrical examination made in a partly darkened room with a Lindsay Johnson lamp.

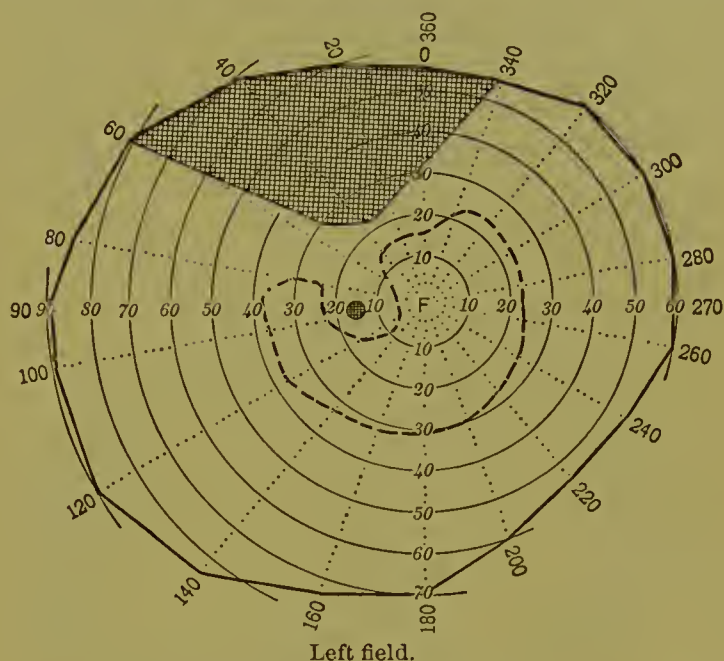
The same thing occurs in the so-called extra-papillary colobomata which Lindsay Johnson considers to be caused by atrophy of congenital *nævi* of the chorioid. In these cases, as well as those of the true macular colobomata, which, according to the experience of this author, occur occa-

---

<sup>1</sup> Archiv für Augenheilkunde, xxi.

sionally, the extent of the scotoma corresponds to the size and the shape of the coloboma in but slight measure, as shown by the ophthalmoscope. Further, the scotomata as observed with the electric lamp are smaller than those that are determined with white paper disks. In one case no scotoma could be made out during the examination with the white paper disk. This was because the portion of the field of vision which held the scotoma was limited to the innermost bounds of the scotoma. Only after examination with the electric lamp was it possible to make the scotoma appear.

FIG. 17.



*Congenital conus* on the inner lower margin of the optic disk, caused by actual absence or imperfect development of the retina, which, according to Wollenberg, is common in the mentally diseased, shows itself in an enlargement of the blind spot. According to Manz,<sup>1</sup> the position of the defect in the visual field in such cases is upward. Sometimes it extends as far as the fixation-point.

*Retinal hemorrhages* do not generally cause disturbance in the field of vision, unless they occur at the macula. The large cup-shaped, round, or oval hemorrhagic foci in the neighborhood of the macula lutea, situated between the retina and the lamina vitrea, cause positive central scotomata.

In the course of resolution of such a hemorrhage the defect grows smaller and gradually disappears. Sometimes a minute area of degeneration remains in or near the macula, and in consequence leaves a small scotoma. As the blood is situated between the arterial layer of the retina and the vitreous humor, the rods and cones remain intact, and the patients perceive the scotoma as red spots. Later everything appears yellowish or grayish.

Small tongue-shaped or roundish hemorrhages in some cases cause the

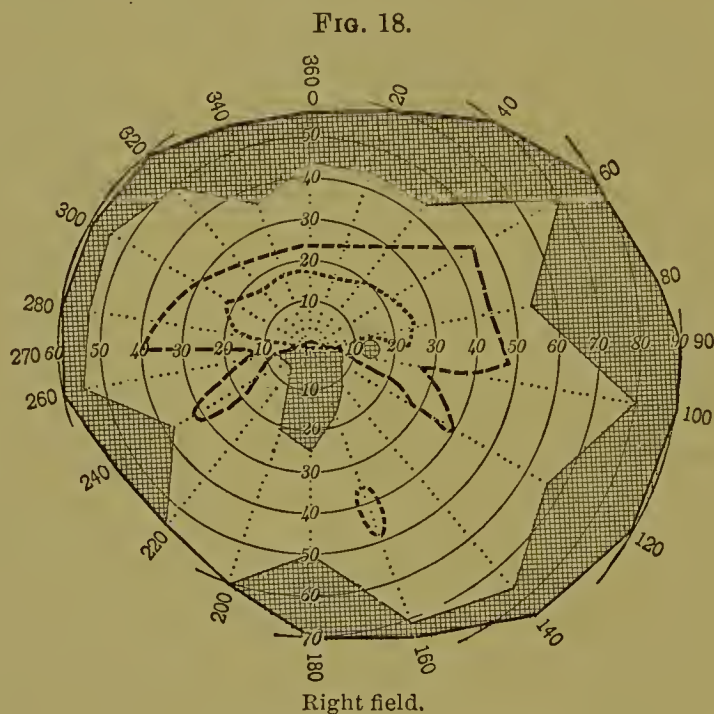
<sup>1</sup> Graefe und Saemisch, Handbuch der gesammten Augenheilkunde, ii. 79.

appearance of sector-shaped defects, especially if the hemorrhages are present in large quantities in the region of a large vessel.

In such cases the field-defect is caused by a lessening in the nourishment of the retina from interference with the circulation of the blood in the diseased vessels, and secondarily by the dioptric disturbance which the hemorrhage causes.

The author's experience leads him to believe that those retinal hemorrhages which occur in consequence of disease of the blood, such as pernicious anæmia and leukæmia, cause less changes in the field of vision than pathological processes which attack the walls of the blood-vessels, as, for instance, atheromatous degeneration.

The field of vision for white is irregularly diminished, with almost always an irregular central scotoma. Fig. 18 shows an absence of color-



perception in the lower part of the field corresponding to the position of the most disturbed portions of the retina.

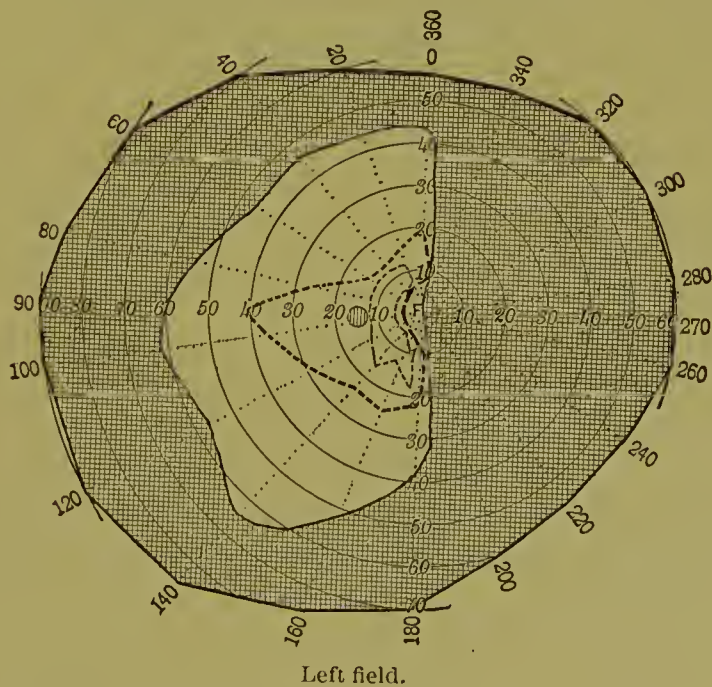
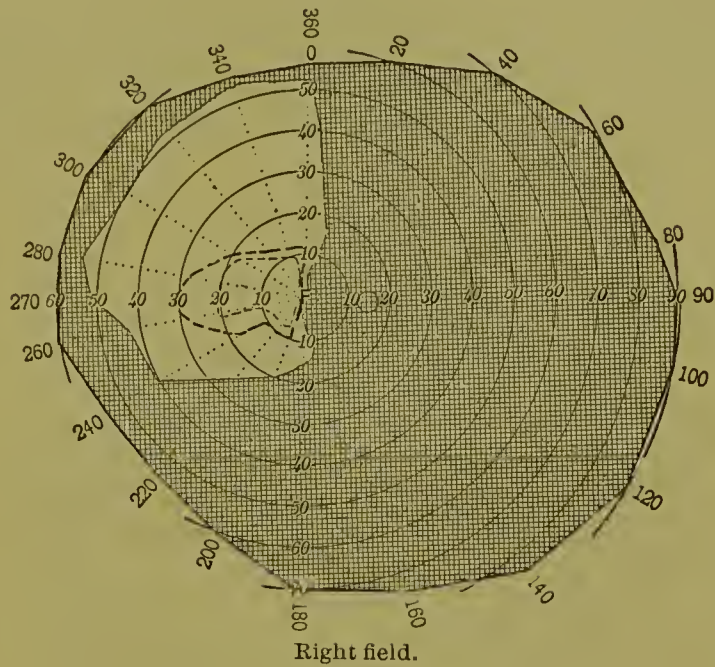
It is remarkable that these conditions often occur unilaterally. Sometimes, usually early, the changes appear in but one position of the field. Analogous changes are caused by disease of the retinal vessels found in late forms of cerebral syphilis. At the same time foci of disease may occur in consequence of thrombosis in the cerebral vessels, so that it may happen that fields of vision (like those seen in Fig. 19) in which the retinal disease has already produced changes may become complicated by a homonymous hemianopsia. The fields of vision in Fig. 19 were taken from a case of cerebral syphilis, with subsequent mania and death from apoplexy.

In those cases of *albuminuric retinitis* in which the changes are marked about the macula, and the patients complain that everything seems to be covered with a greenish sheen, it will often be found that when the field



of vision is examined with small colored objects the color-perception over isolated areas in the macular region is weakened. There is an irregular scotoma for white and colors only where the changes are well developed and marked at the macula, or where there are hemorrhages into this portion

FIG. 19.



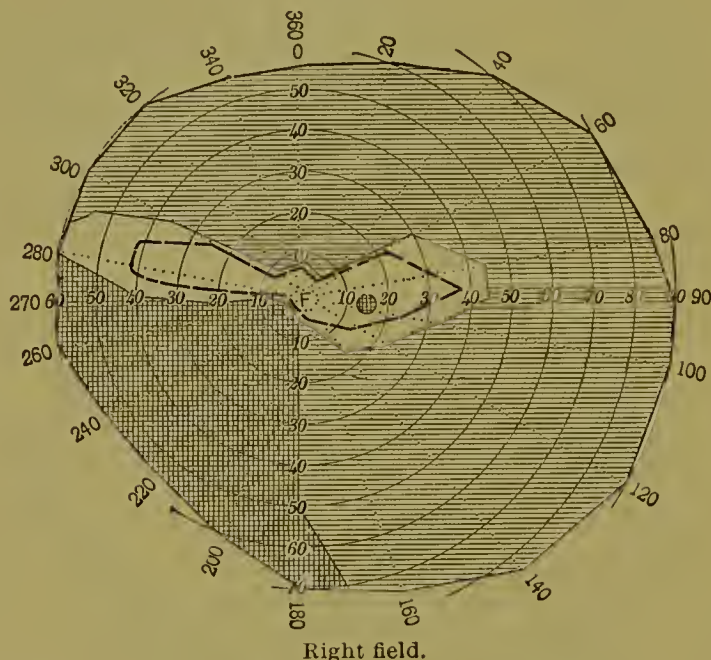
of the retina. Sometimes the peripheral boundary of the visual field is irregularly diminished, being at times produced by an optic neuritis.

Apoplexies often occur which, when the hemorrhage involves the path of optic conduction, may lead to homonymous hemianopsia. Occasionally a temporal hemianopsia may be recognized. It is evident that the addition of hemianopsia to a neuritis or a retinal detachment increases the complica-

tions in the field of vision. Such a field of vision is shown in Fig. 20. In this case, beginning with a normal field, an incomplete left-sided homonymous hemianopsia appeared (the cross-hatched portion). Later an attack of neuro-retinitis occurred in both eyes. During the course of this the single-lined portion of the field lost all visual power, leaving only the small horizontal oval area active.

In that rare form of disease described by von Graefe<sup>1</sup> as *central relapsing syphilitic retinitis* there is a characteristic disturbance of vision,—a series of sudden onsets of a central darkening of vision, with the later develop-

FIG. 20.



ment of an irregularly central permanent scotoma, which may extend as a sector-shaped area to the field periphery. Ring scotomata (see Fig. 5) have also been observed.

In *retinitis proliferans*<sup>2</sup> the condition of the visual capacity is sometimes surprisingly good, when considered in contrast with the great changes shown by the ophthalmoscope, as Leber<sup>3</sup> has recorded in one case. The field of vision was peculiar: it exhibited regularly arranged indentations extending from the periphery. Later, in one eye almost the whole field of vision was lost by the extension of the process inward towards the centre. At last only two small islands, situated at the periphery, remained.

In a case observed by the author at a comparatively early stage, in which the thickening had spread only a short way into the retina, there was an irregular scotoma which connected with the blind spot.

In *embolism of the central artery of the retina* the plugging of the artery

<sup>1</sup> Archiv für Ophthalmologie, xii. 2, 211.

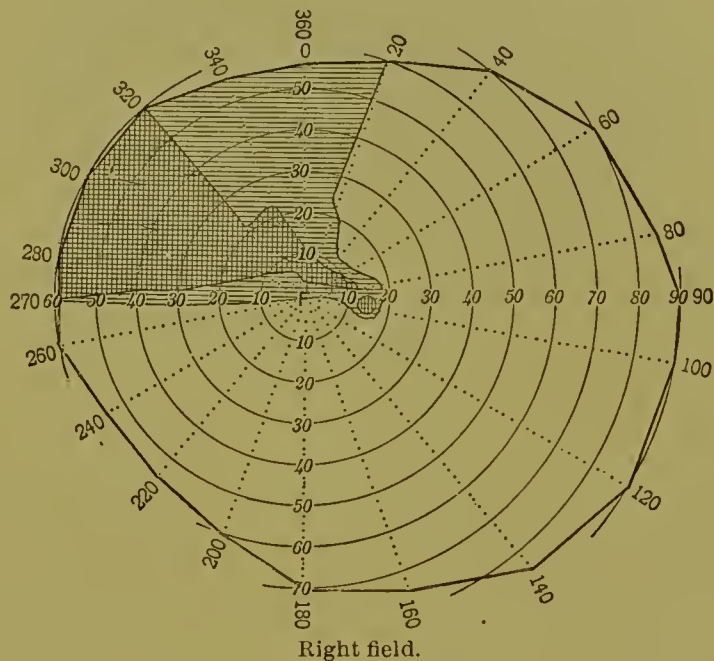
<sup>2</sup> Manz, Archiv für Ophthalmologie, xxii. 3, 229.

<sup>3</sup> Graefe und Sacmisch, Handbuch der gesammten Augenheilkunde, v. 668.

produces sudden and complete blindness of the affected eye, and only in those rare cases in which the lumen of the vessel is not completely occluded does a larger or smaller portion of the field of vision recover where there is a plugging of the small branches of the artery.

At the commencement there is a darkening of the whole field of vision. This is soon followed by a clearing of the field until only that portion from which the blood-supply is completely cut off remains blind. This portion is either situated in the position shown in Fig. 21, or covers the

FIG. 21.



upper or the lower half, according to which division of the artery is plugged. The defect may decrease in size in a few weeks as a consequence of the re-establishment of collateral circulation.

The slit-shaped fields which occur in embolism of the central retinal artery are very interesting. They appear when the twig which supplies the macula springs from the main artery in the trunk of the optic nerve. The field of vision of such a case is shown in Fig. 22. The acuteness of vision in this instance remained normal.

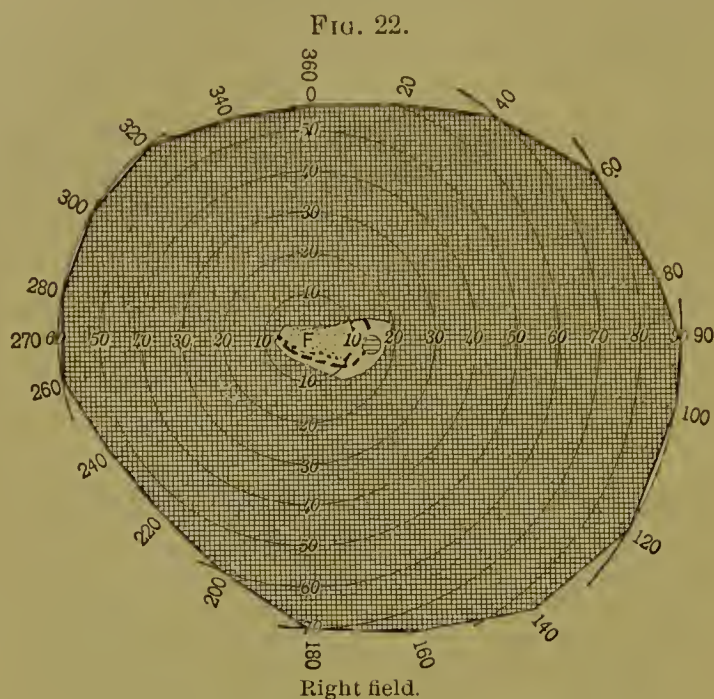
When, in *perforating wounds* of the sclerotic and choroid, the nerve-fibre layers of the retina are divided in a circumscribed region, the perceptive power over the retinal elements which are in the involved region is lost.

The disturbance of function caused by the division of the nerve-fibres spreads, according to the ray-like distribution of these fibres in the retina, as a sector-shaped defect whose base lies at the periphery of the field and whose apex coincides with that of the foreign body. The loss of function is greater than the ophthalmoscopic diagnosis would lead an observer to imagine.

In the cases observed by Jacobi<sup>1</sup> the foreign body was situated below

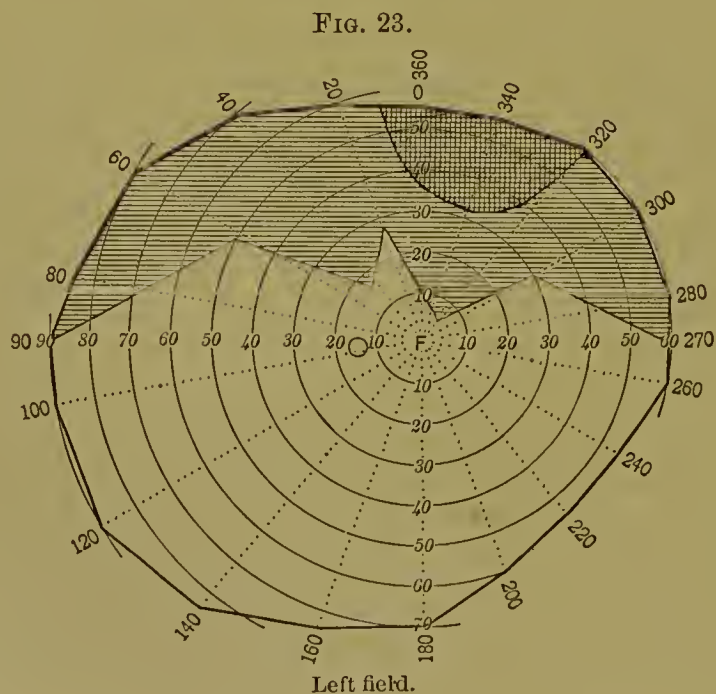
<sup>1</sup> Archiv für Ophthalmologie, xiv. 1, 138.

the papilla. The form of the defect in the field of vision, which was very narrow at the central end, corresponded accurately with the bow-shaped course which the nerve-fibres ordinarily take in the neighborhood of the



macula. Larger wounds which perforate the sclerotic and cause loss of vitreous are usually followed by a separation of the retina.

In Fig. 23 the double-lined portion shows a defect which was caused by a clean-cut wound in the lower and outer part of the sclerotic. One year



later the retina was separated towards the lower part and exhibited a defect in the visual field, shown by the single-lined shading.

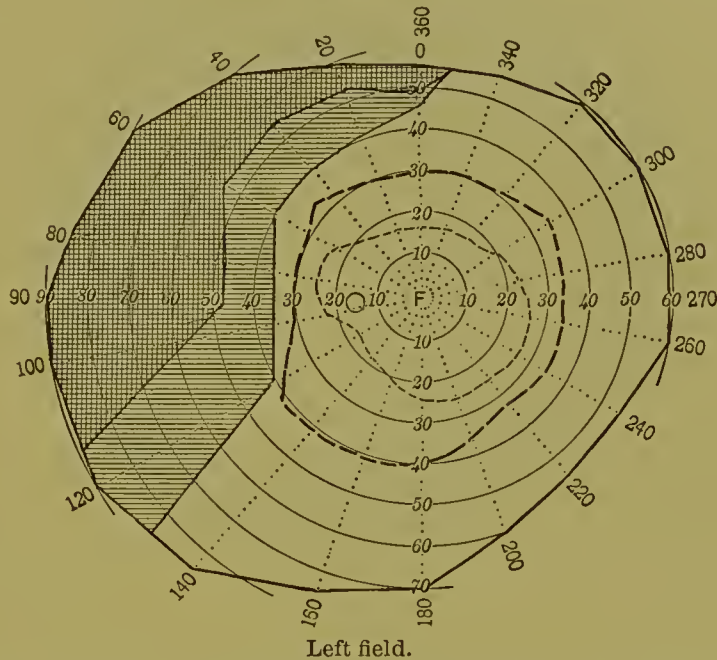
In ruptures of the chorioid caused by blunt objects, the retina is not

generally torn, but the neuro-epithelial layers are often markedly altered by stretching and hemorrhage. The torn area is ordinarily situated at the posterior pole of the eye, and in the greater number of cases it is found on the temporal side of the disk. Rarely the tear is horizontal.

The field of vision is disturbed in accordance with the position of the injury. Central scotomata are observed.

Fig. 24 shows a field of vision from an eye suffering from rupture of the chorioid. The break was caused by pressure of air following an ex-

FIG. 24.



plosion of a dynamite cartridge which the patient was holding between his fingers. The double-shaded portion in the figure shows the defect which ultimately resulted. It was much larger at first (single-shaded portion). The acuteness of vision rose to  $\frac{6}{6}$ .

Fig. 25 shows the field in a case in which a bullet from a revolver crossed from the temporal side to the posterior and upper part of the eyeball. Ophthalmoscopically, at this point dark layers of pigment with glistening white areas could be seen. At the beginning hemorrhages were present.

In *contusions* of the eye clouding of the retina, which is obviously due to œdema, is met with. (R. Berlin.<sup>1</sup>) This condition is followed by a moderate decrease of visual acuteness with temporary concentric diminution of the field of vision.

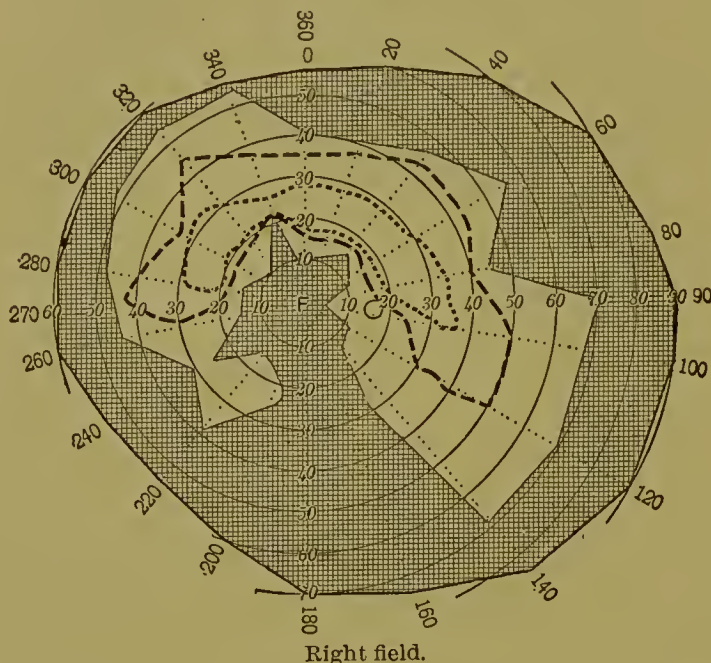
Absolute central scotomata are known to be caused by staring at the sun during eclipses. These may disappear, become relative, or remain permanently positive.

In the form of blindness resulting from bad nourishment, scotomata appear when the patients are examined in diminished illumination.

<sup>1</sup> Klinische Monatsblätter für Augenheilkunde, xi. 42-78.

(Förster.<sup>1</sup>) Alfred Graefe found exactly the opposite to this,—that is, the periphery of the field of vision was disturbed. The measurement of the field of vision is of more importance in *ablatio retinæ* than in all other diseases affecting the retina, for it definitely determines the degree of change of the function in the involved portion. Occasionally during the first few days the function of the retina may appear to be but slightly altered. Leber<sup>2</sup> relates a case in which the whole lower half of the retina was sep-

FIG. 25.



arated and pushed forward like a bag, and in spite of this the field of vision, even during a slightly darkened illumination, showed no sign of diminution. Central vision seemed to be but slightly disturbed.

The separation ordinarily occurs suddenly. It becomes perceptible to the patient by a darkening of the field of vision, and is usually described as a cloud or a curtain spread before a part of the visual field. At the same time, on account of the floating of the still acting retina, a waving of bodies seen in the corresponding field appears. Moreover, by reason of the changed position of the cones, troublesome symptoms of distorted vision may ensue.

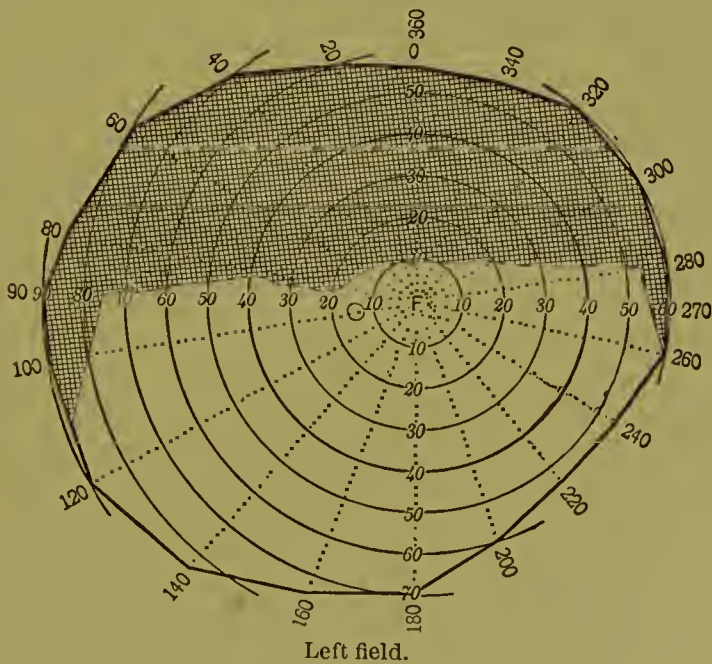
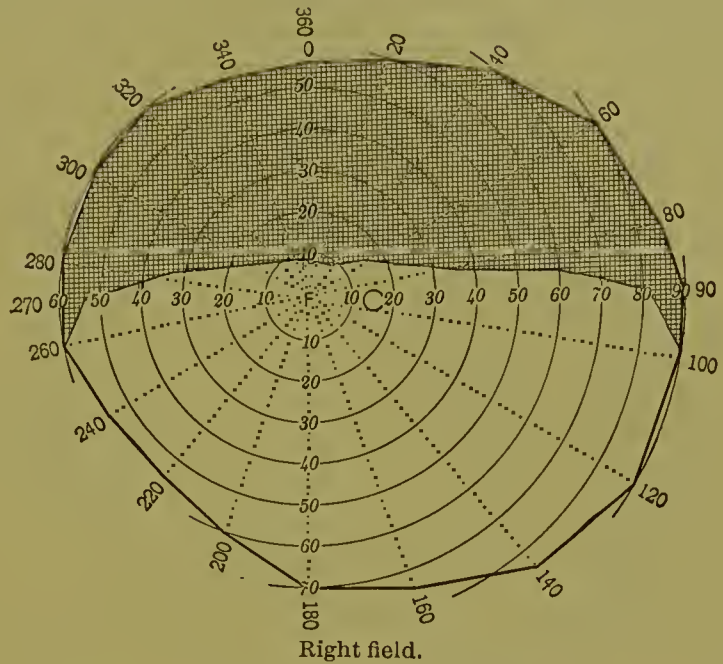
In addition to these symptoms, the disturbed area of the field of vision may rise to the upper part of the field, in consequence of a sinking of the fluid to the lower part of the eyeball.\* Thus those portions of the retina which were separated may again come in contact with the chorioid and resume their function. Sometimes such cases may present a picture in slight measure resembling bilateral upward hemianopsia. This is shown in Fig. 26.

<sup>1</sup> Ueber Hemeralopie und die Anwendung eines Photometers im Gebiete der Ophthalmologie, Breslau, 1857.

<sup>2</sup> Graefe und Saemisch, Handbuch der gesammten Augenheilkunde, v. 694.

If the macula is separated with the rest, eccentric fixation in most cases occurs. In these instances central fixation may be preserved for a longer or shorter period in spite of the decrease of the central acuteness of vision. In consequence of gravitation of the fluid behind the retina, the macula may become reattached and central fixation be re-established.

FIG. 26.



As every separation of the retina has a tendency to increase in size, the defect in the field of vision gradually augments until only a slight perception of light in the lower part of the field remains. The apparent size of the separation as shown by the ophthalmoscope is not always represented by a similarly sized defect in the field of vision. In cases of visual field-defect without any demonstrable elevation of the retina, the visual power

may be so much improved that no eccentric visual disturbance can be shown in ordinary daylight. In such cases the field-defect may be demonstrated by means of diminished illumination.

The disturbance of function of the separated retina depends principally on the changes wrought in the rod-and-cone layer of the retina. These delicate elements become macerated, producing torpor retinæ. In such cases it often happens that central acuteness of vision is disturbed on cloudy days. In these instances, however, the defects in the field of vision are better shown by diminished illumination than by daylight.

If the retina has been separated only a short time, and no anatomical changes of its inner layer have occurred, this part may regain its original power of perception of light. It is to this form of torpor retinæ that the phenomenon of a dark cloud or wall similar to that seen in positive scotomata is to be ascribed.<sup>1</sup> The reason for this is that by daylight the separated and sound portions of the retina are excited by almost equal strengths of stimulus. When less illumination is used the stimulus in the separated region is lowered, and hence the scotomata must appear.

*Retinitis pigmentosa*, or pigmentary degeneration of the retina, is the only disease among all the pathological conditions of the retina which produces typical changes in the field of vision.

At the commencement of the disease the field of vision by bright illumination shows no change from normal, whereas by examination with diminished light a considerable concentric decrease can be demonstrated.

The disturbance of vision depends on the destruction of the rod-and-cone layer of the retina, which cannot be recognized with the ophthalmoscope. In typical cases the disease develops in the periphery and spreads in the direction of the macula lutea. Whilst at the beginning a concentric shrinking of the field of vision can be shown with diminished illumination, in full daylight the boundaries of the field are normal. As the disease progresses, the concentric shrinking of the field appears also in the bright illumination of daylight, a sign that the rod-and-cone layer is destroyed. If the field be examined by diminished illumination at this time, it will be found that the concentric shrinking has advanced so far that the eye appears totally blind,—a proof that the torpor has spread over the whole retina.

The diameter of the field of vision with good central acuteness of vision can diminish to an area of from seven to ten degrees in extent. Such patients see as does one looking through a long tube. In this area, by bright daylight, the color-fields are recognized in their usual order.

Occasionally so-called ring scotomata appear. In the peripheral portion vision is defective either throughout or in isolated areas. Sometimes ring scotomata are complete. Again, they may consist of half-circles which are separated by fairly well reacting portions of the field. At times the

---

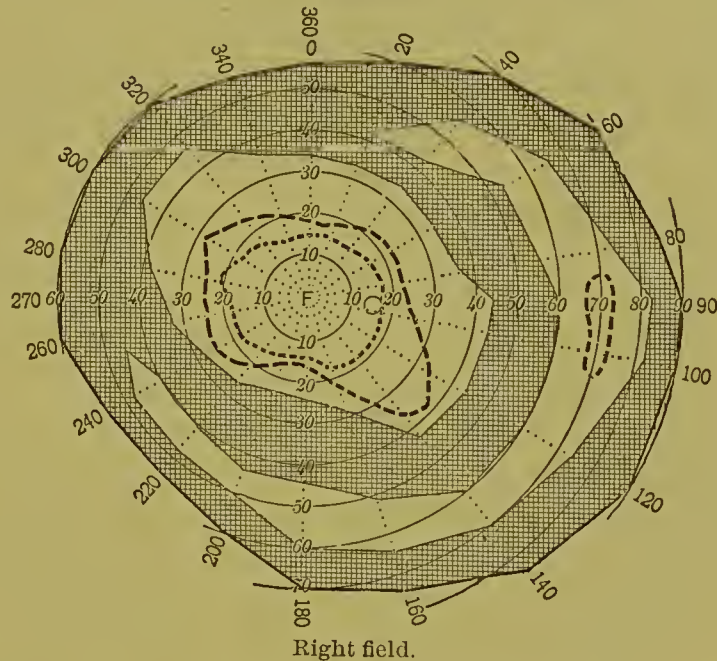
<sup>1</sup> Förster, *Klinische Monatschrift für Augenheilkunde*, ix. 341.



remaining active part of the centre of the field is surrounded by a half-moon-shaped area (see Fig. 27), giving the working field of vision a resemblance to the star and crescent of Turkey. These half-ring or zonular defects of which the ring scotomata are formed, as well as the ring scotoma itself, are often found in chorioido-retinitis of syphilitic type,<sup>1</sup> as well as in central relapsing syphilitic retinitis as described by von Graefe.

In the beginning of syphilitic chorioido-retinitis, described by Förster, the field of vision when examined by bright daylight is either normal or

FIG. 27.



slightly diminished concentrically. Island-shaped and zonular defects first appear in diminished illumination. Central scotomata are sometimes observed. Schoen<sup>2</sup> regards the mode of origin of these annular scotomata as following the arrangement of the vasa vorticosa. Upon account of their rich blood-supply, these zones of vessels are specially prone to inflammation, taking at the same time a position coinciding with that of the centre of the ring scotomata ( $30^{\circ}$  to  $35^{\circ}$ ).

Perlia<sup>3</sup> has made a careful collection of the cases of annular scotomata from all the writings on the subject. He has found thirteen cases of syphilitic chorioido-retinitis, two of non-syphilitic chorioido-retinitis, seven of retinitis pigmentosa, and one in which no ophthalmoscopic diagnosis was made. Thus no less than 56.5 per cent. is referred to a syphilitic origin. Hence in every case of ring scotoma syphilis must be first considered.

A ring scotoma disappears in the same way as it is formed. It is broken into zonular defects, which become smaller and are demonstrable only by

<sup>1</sup> Förster, *Archiv für Ophthalmologie*, xx. 1, 32.

<sup>2</sup> *Die Lehre vom Gesichtsfeld*.

<sup>3</sup> *Centralblatt für Augenheilkunde*, 1886, S. 41.

diminished illumination, and at last pass out of existence. In the closing stages of chorioido-retinitis island-like spots of vision around the large central defects are alone found. These areas are most plentiful in the peripheral parts of the field, causing this portion to appear retiform in character,—the so-called *visus reticulatus*.

According to Nettleship,<sup>1</sup> there is both a chorioiditis and a retinitis of syphilitic type. They are constantly found associated in the chorioidal variety. The primary seat of inflammation is in the capillaries. The disturbance seems to show a greater tendency to spread along the surface than to involve the thickness of the vascular layer.

The principal change occurring in pure syphilitic retinitis is a diffuse thickening of the retina in all its layers. This thickening shows itself most distinctly in the nerve-fibre layer, where the cells appear heaped in masses.

The areolar and circumscribed forms of *chorioiditis disseminata* exhibit fields of vision which are dependent upon the seat of the disease and the method of extension through the retinal layers. Here, notwithstanding the striking pictures which the ophthalmoscope gives, a precise examination of the whole field of vision with a small object can alone show where and to what degree the rod-and-cone layer of the retina is affected. In chorioido-retinitis ad maculam the outer layers of the retina in contact with the disease are usually involved, and the metamorphosis is produced by disturbance in the sensitive layers. This leads to the formation of a positive central scotoma of an atypical form, its shape varying with the size of the disease-foei. At first white objects appear darker in the affected region than ordinary. Later there is an absolute scotoma.

In some cases of chorioido-iritis disseminata in which there are marked ophthalmoscopic changes a normal field of vision is found. In such types the tissues of the chorioid and the iris alone are affected. In other cases the foci of disease lie nearer the retina and cause the appearance of circumscribed absolute scotomata in the intermediate zone of the visual field. At times a central scotoma may be present, giving a sieve-like appearance to the field, so that to some extent the patients see as through a sieve. (Fig. 10.) In addition there may be wide-spread peripheral defects.

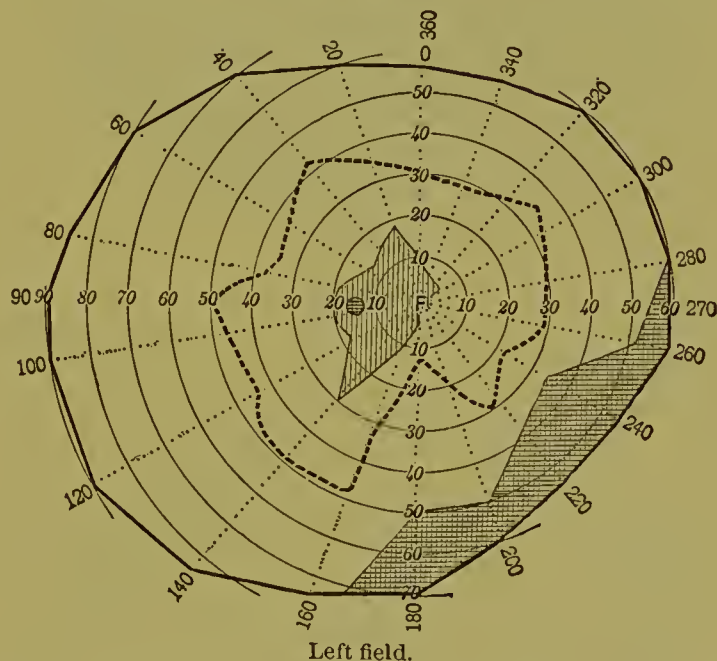
In *sclero-chorioiditis posterior* there is an occasional increase of the blind spot, which signifies that there is atrophy of both the chorioid and the rods and cones. Owing to changes in the nourishment of the chorioid in high degrees of myopia, torpor retinae occasionally occurs. This condition produces a still greater degree of concentric diminution of the field, as shown by diminished illumination, than is usually found in myopia. If to this an inflammation of the vascular layers be superadded, it will be easy to understand why very short-sighted patients, notwithstanding complete correction of vision by lenses, find it hard to orient themselves in twilight.

---

<sup>1</sup> Royal London Ophthalmic Hospital Reports, vol. xi., Part I.

In the prodromal abortive attacks of *glaucoma* both central acuteness of vision and the field of vision are diminished. After the first severe attack the visual power never regains its normal condition. The decrease in the field of vision, which is more or less concentric or localized to the nasal half, is a consequence of intra-ocular pressure. This compression shows itself first and chiefly in those vascular regions which lie farthest from the heart, for here the blood-pressure is least. Hence an anæmic condition in the retinal periphery, which is the cause of the diminution in the field of vision, is early recognized. As the optic disk lies to the nasal side of the posterior pole of the eye, the vessels which supply the temporal side of the retina travel farther in carrying the blood, and thus, their capillaries lying at a greater distance from the heart, the field of vision on this side (which is the nasal side to the perception of the patient) is most diminished. (Compare Figs. 28 and 30.)

FIG. 28.



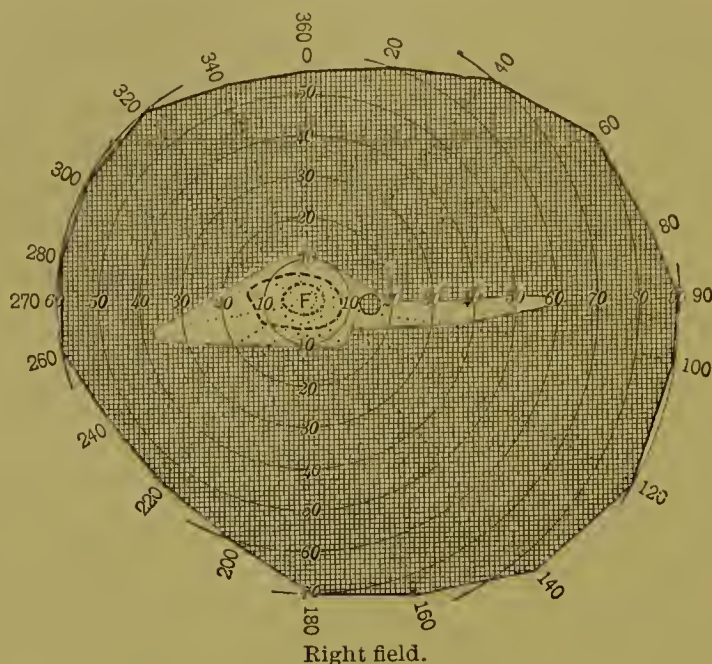
If the disease goes so far as to form a pathological excavation, both central acuteness of vision and the visual field suffer still more, by reason of atrophy of the optic nerve fibres in the head of the nerve from pressure. After iridectomy central acuteness increases, owing to increased transparency of the cornea, whilst the field of vision returns to normal so far as the eye was healthy before the attack.

In *simple glaucoma* the field-disturbance depends upon the atrophy caused by pressure on the nerve-fibres in the cupped disk. On account of a slow and gradual increase of this pressure, the fibres adapt themselves, being mostly pushed over to the nasal side of the disk, so that the condition of visual acuteness and the field of vision do not always correspond with the depth of the cupping. Thus, Schmidt-Rimpler<sup>1</sup> describes a case

<sup>1</sup> Eulenberg's Realencyclopädie, Bd. vi.

in which, although glaucoma symptoms were present for between ten and twelve years and a deep cupping existed, visual acuteness and the field of vision were normal. If there is an additional concentric diminution of the field, a narrow horizontal or an oblique area may be all that is left. (See Fig. 29.) Usually for a long time before complete blindness ensues

FIG. 29.



a small remnant of vision is present in the outer upper or outer lower quadrant of the field. Sometimes at the commencement a relative central scotoma (see Fig. 28), which gradually grows into an absolute area, appears.

Sachs<sup>1</sup> has examined four fields of vision in simple glaucoma in which paracentral scotomata were present. In these cases the meridional boundary was from two to four degrees separated from the fixation-point, and the lateral boundary included most of the blind spot.

Schnabel<sup>2</sup> found, among one hundred and eighty eyes suffering from primary glaucoma, fifteen with a greatly diminished field of vision and a high degree of central acuteness. He also saw six cases with central and paracentral scotomata. Fifteen per cent. exhibited a condition of function indicating retrobulbar neuritis.

In simple glaucoma, though central acuteness of vision generally decreases slowly, yet it can be normal whilst diminution of the peripheral area is far advanced. In a narrow slit-like area color may be recognized. (See Fig. 29.)

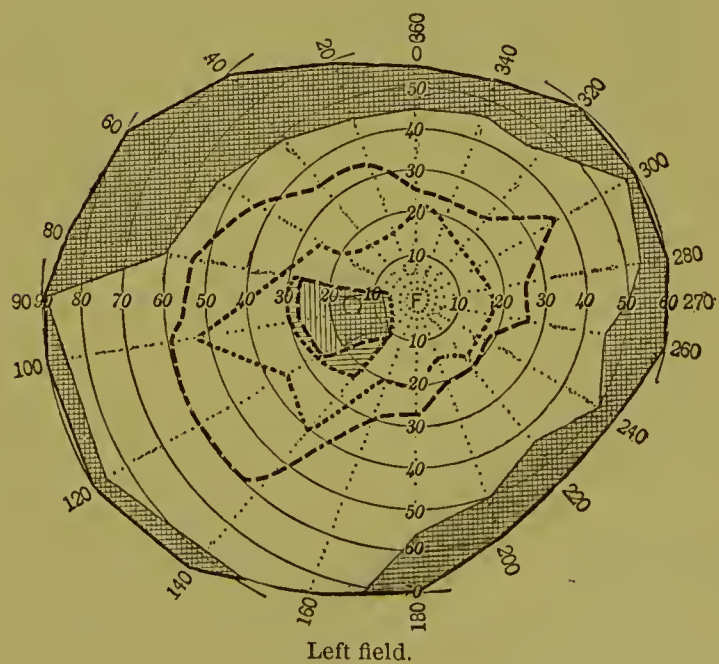
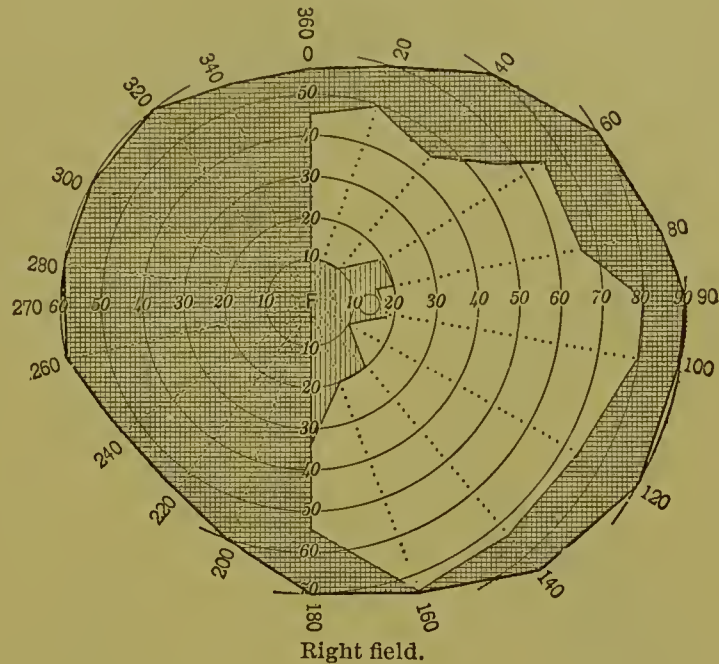
If the field of vision is narrowed to the fixation-point before a sclerotomy or an iridectomy is performed (see Fig. 30, in which the lined part represents the area of growth of defect after operation), there is generally

<sup>1</sup> Centralblatt für Augenheilkunde, 1887, 161.

<sup>2</sup> Archiv für Augenheilkunde, Bd. xxiv.

an increase of the mischief after the procedure, the increased narrowing passing beyond the fixation-point and destroying central vision. These are examples of simple glaucoma which can be easily mistaken for simple optic atrophy with unusually deep cupping of the disk. In doubtful cases the presence of color-perception in the remaining field of glaucoma will serve to differentiate the two conditions.

FIG. 30.

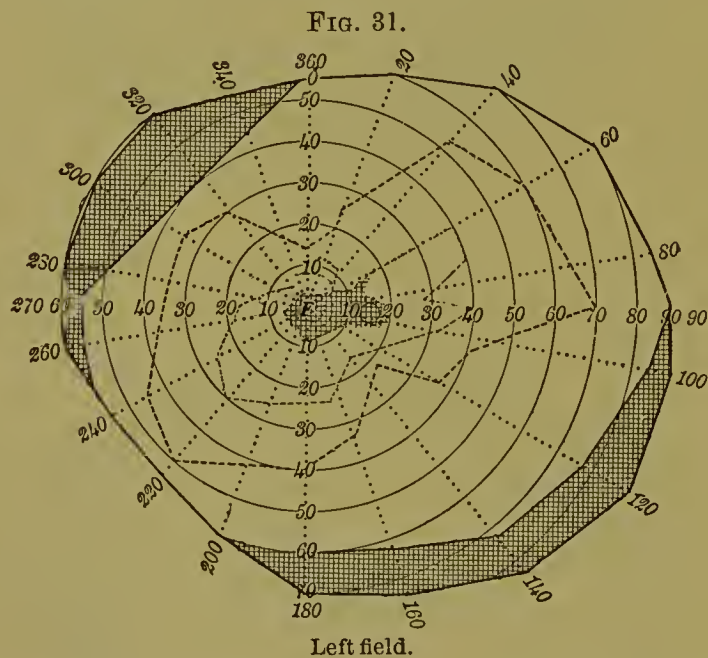


The field of vision in *choked disk* (papillitis) and *papillo-retinitis* appears in marked contrast with the ophthalmoscopic signs. As long as the choking of the disk is due to œdema the conductivity of the nerve-fibres remains but slightly affected. When the hyperæmia and infiltration of the papilla develop slowly it does not seem to be disturbed, the nerve-fibres

having opportunity to move to one side, as in glaucomatous conditions, and to become adapted to their new position. Thus, Ivanoff found in a case of Becker's<sup>1</sup> that although the process remained for a year in a condition of high degree of pressure, with comparatively great increase of the capillary circulation, yet there was normal vision.

Lately the author has had an opportunity to observe a case in which, in consequence of an abscess of the temporal lobe consecutive to purulent ear-disease, choked disk developed. After trephining and cleansing of the abscess-cavity, the nerve-head swelling disappeared without leaving diminution of acuteness of vision or disturbance in the visual field.

Early, and often before any diminution in the periphery of the field is present, an increase in the size of the blind spot, varying from twice to many times its normal size, may be found. This condition, which was first observed by Knapp,<sup>2</sup> is chiefly caused by the pushing aside of the retina round the papilla by the so-called neurotic swelling. (In Fig. 31 the size of the blind spot is shown by the double-lined portion.)



In the course of the disease a continuous diminution of the field ensues. This is greatest on the nasal side, and is accompanied by angular- or sector-shaped defects, with retraction of the boundaries of color-perception from the edge of the defective white field. (See Fig. 32.) In a few cases the fault is seen in both eyes on the nasal half only. Mandelstamm has incorrectly endeavored to designate this condition as an example of the so-called nasal hemianopia.<sup>3</sup>

As a rule, the visual disturbances and changes in the field of vision are due to the rapid development of the choked disk caused by the œdema and

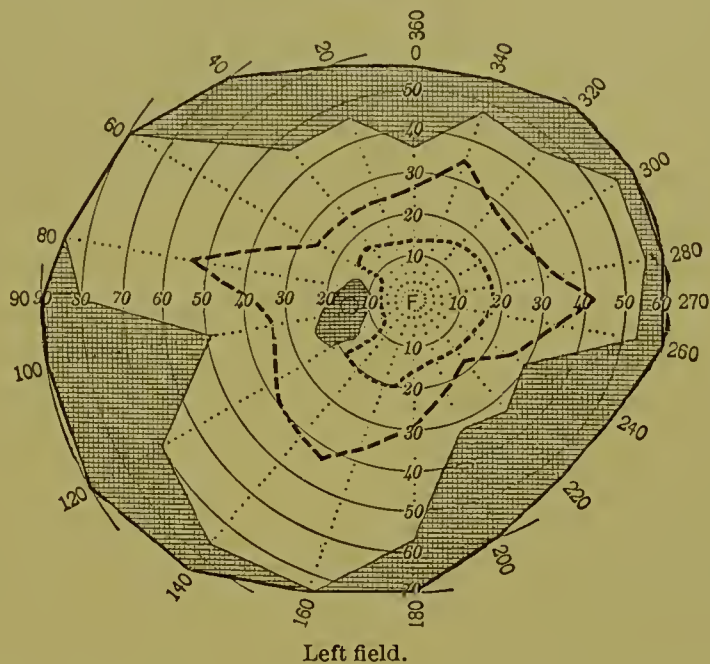
<sup>1</sup> Graefe und Saemisch, *Handbuch der gesammten Augenheilkunde*, v. 781.

<sup>2</sup> *Transactions of the American Ophthalmological Society*, 1870, p. 118.

<sup>3</sup> *Archiv für Ophthalmologie*, xix. 2, 39.

dilatation of the capillaries. With the commencement of the stage of inflammation and papillary atrophy, conduction is destroyed by the newly formed connective tissue, as it grows and contracts, causing rapid loss of visual power. During these processes the field of vision is continually lessened, color-perception is gradually lost, and finally incurable blindness

FIG. 32.



sets in, the last remnant of the field in which large white objects can be seen being situated external to the fixation-point.

There is a diversity of opinion as to which side of the field the diminution most often affects. Schlüter,<sup>1</sup> after collecting the peculiarities of the field of vision in thirteen cases of choked disk and neuro-retinitis of cerebral origin, found as follows: six times (in three patients) enlargement of the blind spot; three times (in two patients) peripheral diminution, particularly from above; twice (in one patient) peripheral diminution, particularly on the outer side; twice (in two patients) small remains of the field towards the lower part; twice (in one patient) marked concentric diminution with retention of color-perception; twice (in one patient) remains of the field below and above the fixation-point; and once (in one patient) a large and absolute central defect.

The course of choked disk and its destructive results to central visual acuteness and the field of vision depend not only on the nature of the intra-cranial disease-processes, but also partly on the result of the therapeutic or surgical measures which have been undertaken early in the disease. Here there is direct pressure or other influence of a tumor at some distance from the nerve, bringing about a decrease in the intra-cranial space and acting directly on the optic tracts and the visual centres.

Patients suffering from choked disk sometimes complain of previous

<sup>1</sup> Ueber Neuritis Optica. Inaugural Dissertation, Berlin, 1888.

blindness or diminution of visual power. These are symptoms that follow distention of that portion of the cerebrum which forms the roof of the third ventricle over the optic chiasm. Hydrocephalic effusions, causing augmentation in the quantity of cerebro-spinal fluid, produce pressure upon the optic chiasm, and thus diminish the conducting power of the retinal impulses from both eyes through this body. Those reductions of visual power which appear at the beginning of the disease are therefore always about the same in both eyes. If such patients bend forward, the visual power is diminished by the greater pressure which follows the engorgement thus brought about. A like character of blindness can be caused by the pressure of an expansile tumor upon the chiasm in a case of choked disk.

If the choking is caused by disease-processes in the orbit, the field-defect essentially follows the point on which a tumor, for example, acts on the nerve-fibres, or physiologically represents the position of those fibres in which the mass grows. Thus, Schlüter observed in a patient twenty years of age, whose peripheral field of vision and color-perception were good, that the fixation-point was covered by a large absolute scotoma, which extended inward a great distance.

If typical choked disk with marked differences in the two fields of vision is present in a case of cerebral syphilis, a greater involvement of the optic trunk, which eventuates in a descending destruction of the nerves, must be suspected. For instance, if in a double choked disk, caused by intra-cranial syphilis, one eye becomes almost blind, whilst the other regains normal vision, a direct involvement of the optic trunk of one side, either in the cranium or in the orbit, may be assumed.

## II.

### THE FIELD OF VISION IN DISEASES AFFECTING THE OPTIC NERVES.

In such conditions both neurotic and atrophic changes must be considered. The first may be divided into the acute and the chronic forms and combinations of forms of peri-interstitial neuritis, isolated neuritis, and inflammation of the fibres forming the papillo-macular bundle. The inflammation may spread in an ascending or a descending direction from the brain (perineuritis or neuritis ascendens or descendens). Again, it may attack any point in the nerve and extend in both directions from this point.

The atrophic conditions of the optic nerves may be divided into simple genuine optic-nerve atrophy (*atrophia nervi optici*); neurotic atrophy, which follows the action of inflammatory processes in the optic nerves; and secondary atrophy (ascending or descending), as, for example, that following pressure on the optic nerve or division of the nerve in its continuity.

The disturbances of vision in inflammatory processes attacking the optic nerves are caused partly by the destruction of conduction in consequence of swelling and increase of the connective-tissue septa pressing on the nerve-fibres, and partly by the disturbance in the nourishment which



the inflammation produces in the connective-tissue septa in diminishing their capacity as conductors of nourishment. So long as these processes of diminished nourishment and pressure interfere only with the action of the nerves without destroying their anatomical integrity, the disturbance of sight may completely disappear on their subsidence; otherwise such disturbances are irreparable and deficient vision is permanent.

In simple true optic atrophy visual changes are generally caused by an evenly spreading loss of power in the separate nerve-fibres of the whole transverse section of the optic nerve. The condition, without any known reason, is progressive, and always results in blindness.

In neurotic atrophy the visual changes depend upon the size and intensity of attack of the affected portion of the optic nerve as well as upon the frequency and permanency of the disturbances of nourishment to which the several separate bundles of optic nerves are exposed.

In secondary descending atrophy the degree of visual defects is commensurate with the interruption of connection of the nerve-fibres produced by disease of their ganglion-cells.

With regard to the constant relation of the ophthalmoscopic diagnosis to the disturbances of central acuteness and the field of vision in neurotic affections of the optic nerves, the following queries must be kept in view: 1. Do the inflammatory processes extend into the papilla, or do they extend behind the orbit into the intra-cranial part of the optic tract, or have they their seat in the tracts themselves? 2. How much time has passed since the commencement of the disease?—that is, how long is it since the disturbance of vision appeared?

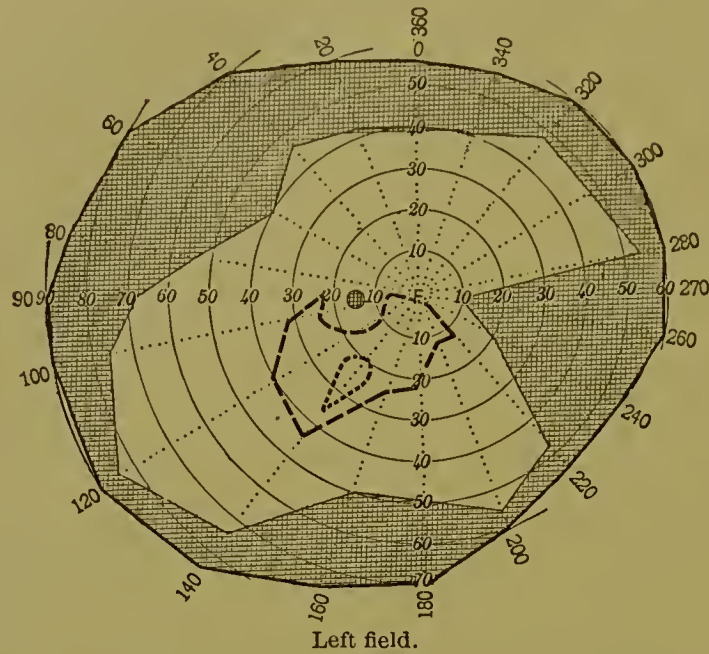
If the signs of a neuritis are found ophthalmoscopically, they give in a measure directly also the explanation of the changes in the field of vision seen at the same time.

In diseases of the optic nerves, and chiefly in the primary atrophic conditions, the degree of acuteness of vision and the diminution of the field of vision for white and color bear a regular relation to each other, which is of the greatest importance for diagnosis and prognosis.

In simple true progressive atrophy of the optic nerves, where the degeneration has attacked in a more or less regular manner the whole optic tract, defects first appear in those portions of the field whose corresponding retinal areas ordinarily exhibit in the normal physiological condition weaker visual acuity. For this reason the early defects are found towards the periphery of the field. In consequence of this, examining objects reflecting colored light that is less intense than white show at this period of the disease a marked decrease in the limits of the color-field towards the fixation-point. (See Fig. 33, which is the field of a case of progressive optic atrophy in a forty-year-old tabetic.) As the atrophic process progresses, those colors which, under ordinary physiological conditions, exhibit a tendency to disappear first in the field, fade in regular sequence. Hence, for example, the color-blind zone between the fields of blue and white increase in size, whilst

over the entire field green and red cannot be seen, followed by loss of perception of every color except blue. (See Fig. 34, which represents the field of vision of the right eye of the same case as in Fig. 33.) Fig. 35

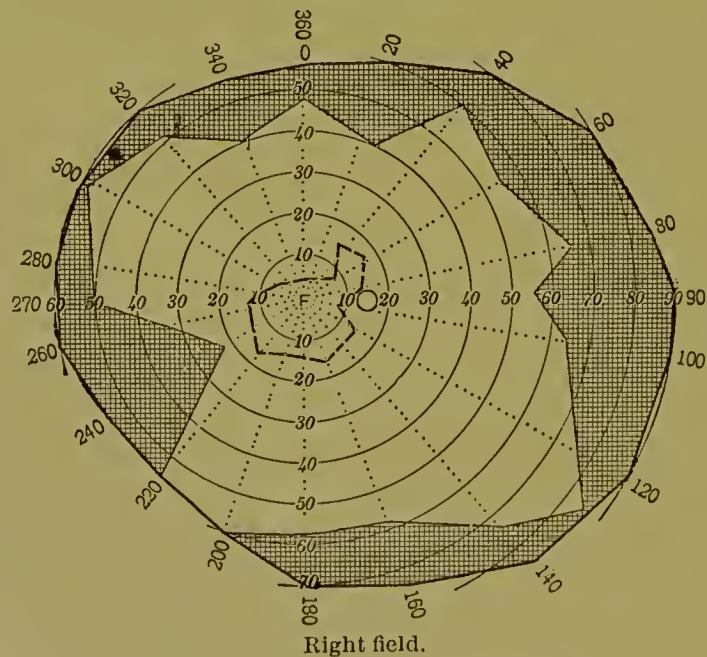
FIG. 33.



exhibits the last remnant of a color-blind field of vision in the progressive optic atrophy of tabes dorsalis.

With a normal field of vision for white, a marked diminution in the

FIG. 34.

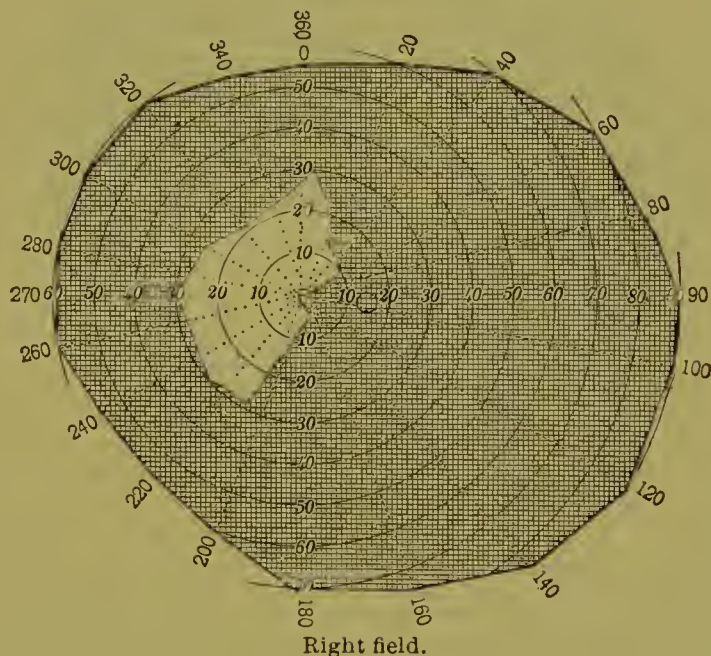


limits of the color-fields, which is to be regarded as a symptom of the commencement of progressive atrophy, may be found. In all cases of simple progressive atrophy, therefore, the relation of the extent of the field for white to that of the fields of the colors, when examined with equal-sized

objects, corresponds exactly to the diminution of such fields to a normal eye when examined with decreased illumination.

If it be wished to compare the size of the color-fields with that of the white field in ordinary daylight, a gray surface that is just large enough to show the extreme limits of the normal field by the illumination of bright daylight should be used as the examining object. In this way a diminution of function in the optic nerve, in an atrophy that spreads evenly over the whole nerve, may be recognized without any limitation of the periphery of the field manifesting itself when examined by means of an ordinary-sized white object. On the contrary, however, any derangement is shown

FIG. 35.



in the limitation of the color-fields, because colored light has less power of impressing itself on the retina than white light; and, further, under normal conditions colored light makes an impression which gradually lessens as it impinges upon the retina from the fixation-point, until at last it produces the impression of gray.

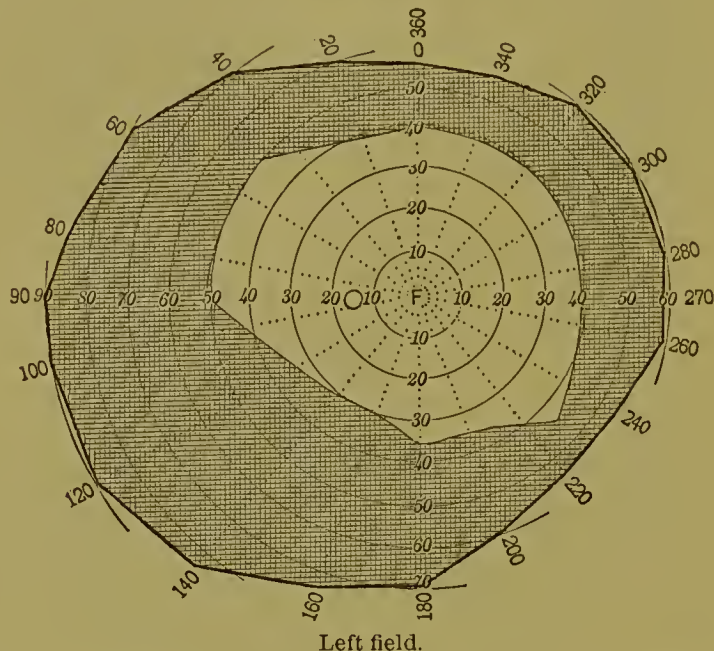
If a sector-shaped area of the optic nerve is attacked more intensely, and projects a similarly-shaped defect into the visual field of white light, the field for blue will exhibit a diminution following the conformation of that of the white light. (See Fig. 43.) The color-blind zone between the limits of the fields of white and blue, where they are encroached on, becomes narrower at the part of the sector which is nearest the fixation-point, and wider towards the periphery of these fields. The reason for this is that the sensitiveness of the central part of the retina is much greater than it is towards the periphery. If the limits of the color-fields approach closely to the boundary of the defect in the white field, it proves that the eccentric acuteness of vision still remains near normal.

As the area and intensity of a defect in the visual field are only relative

to the size of the test-object used and the degree of illumination, it is uncertain to what degree the physiological function is lost. An absolute defect is spoken of only where the affected regions are absolutely blind to the most powerful light that can be employed.

Fig. 36 shows a field of vision tested with a white object whose sides were one hundred millimetres long. When the same patient was examined with a white object whose sides were five millimetres long, no perception of

FIG. 36.



light could be demonstrated. In this case large blue surfaces appeared a little bluish. A similar condition was present in the other eye. The patient suffered from tabetic progressive atrophy of the optic nerves.

In most diseases affecting the optic nerves the line of demarcation between the relatively healthy and the absolutely defective portions of the field of vision consists in a zone in which visual perception is markedly diminished. This intermediate portion lies between the limits of the absolute defect and the boundaries of the field for green. The number of the diseased nerve-bundles may, to a certain extent, be determined in accordance with the width of this zone.

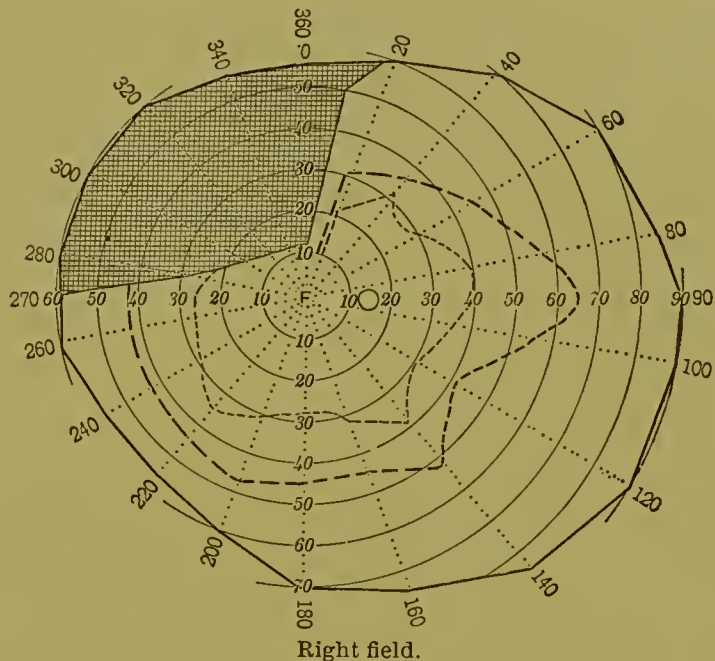
If a defect reaches into the boundaries of the normal color-fields and divides both them and the field of white, so that the limits of the two series of fields coincide, such a condition of disease is known as *partial atrophy*. It does not affect the rest of the field, whose limits for white and color remain normal. (See Fig. 37.) Such a field shows a past circumscribed process of disease, and indicates a favorable prognosis. Uthoff has described a classic diagnosis of such a condition.<sup>1</sup>

In some diseased conditions of the optic nerves there is usually, outside the limits of the defect found when examined with a white object five

<sup>1</sup> Archiv für Ophthalmologie, xxxii. 131.

millimetres square, a zone of partially deadened perception which gradually shades into the defective portion. With large white strongly illumined objects this zone is also demonstrable, the patient sometimes, in cases of progressive optic atrophy, becoming conscious of it because objects which are moving away seem to be gradually enveloped in a fog before being lost. This fog which surrounds the boundaries of the pathological field of vision appears brighter on the side of the field towards the light, and is broader in proportion to the smallness of the limits of the field for white.

FIG. 37.



In progressive atrophy, even after no field of vision can be obtained by a five-millimetre white object and the patient has lost the power of counting fingers, there is often present for a long time the power of preception of intensities of light. Fig. 36 was obtained by using an object one hundred millimetres square. Later this condition is followed by blindness.

In regard to prognosis as shown by field-disturbances, the disease should be regarded as progressive under the following circumstances: 1. When it can be proved, after repeated examinations with similar objects and quantities of light, that there is a constantly increasing shrinking of the bounds of the color-fields from the limits of that of white, or that the white field is diminishing. If only one side or one sector of the field is diminished, a further shrinking in the field of white at this part of the visual field is to be expected. 2. When the field of vision for white begins to shrink, whilst there is a constant diminution of the fields for colors. 3. When in the course of repeated examinations red or green objects of like size to the white one are not recognized in bright daylight, although larger objects of these colors can be seen.

In making examinations for defective color-vision it must be borne in mind that the patient may be congenitally color-blind. Further, it must

be remembered that a congenital hemeralope may become subject to disease of the optic nerves. In such cases examination with lessened illumination differentiates the condition. In disease of the optic nerves which are not hemeralopic the visual field shows the same area as when the illumination is markedly diminished.

A retrogressive tendency in the condition of the disease is present and the prognosis is more favorable when, on comparing with earlier examinations, it is found: 1. That the limits of the visual field for white and color have increased when examined with similarly-sized objects. 2. When, with a stationary condition of the limits of the color-fields, the white field exhibits an expansion when examined with similarly-sized white objects. 3. When, after an earlier loss of vision of green and red, or of green only, these colors become recognizable. 4. When the same extent of field as was determined with a large colored object is found with a similarly-colored small object. In all this work it is essential to know whether the patient has taken any strychnine.

The process of retrogressive evolution after a subsidence of the inflammatory conditions may cease at any time, and the condition which is then reached may become permanent.

The relation of central visual acuteness to the defects of the visual field in diseases of the optic nerves cannot be regarded as a constant one. With Jacobsohn, the author formulates the following rules: 1. If central visual acuteness and the visual field are synchronously diminished, it is a sign that the disease has attacked the whole optic tract. 2. If central visual acuteness is diminished and the visual field is lessened by sector-shaped defects which seem to cut into the field from the periphery, it is a sign that, though the whole optic tract is affected, yet those parts related to the sector-shaped defects are more disturbed. 3. If central visual acuteness is markedly diminished, with a relatively free periphery in the visual field, a central scotoma, which may be relative or absolute, is to be suspected. From the fact that the central visual acuteness, in contrast to the peripheral visual acuteness, is not only absolutely but relatively better preserved, the author believes that the conclusion may be drawn that the disturbance of function in optic atrophy shows a tendency to spread commonly in a centripetal direction.

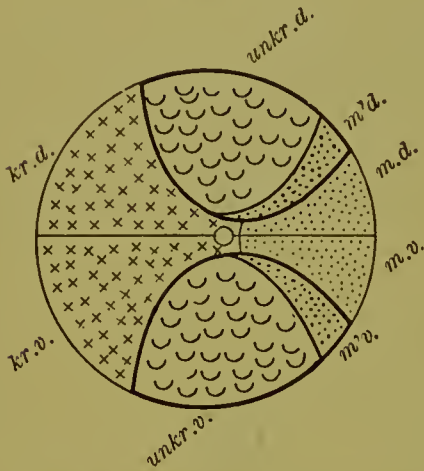
In some rare cases the centre of the retina and the part immediately around it act almost normally, whilst all the rest of the membrane shows a high degree of visual acuteness or is completely blind. In such instances the disease-process has stopped without touching the fibres of the papillo-macular nerve-bundle. Up to this time there is no actual proof whether this condition may remain permanently or not.

It seems necessary at this point to discuss in a few words the anatomical condition of the optic nerves as given by Henschen.

(a) The macular bundle lies ventro-laterally in the papilla and also immediately behind it. At the latter place it forms a keystone-shaped sector,

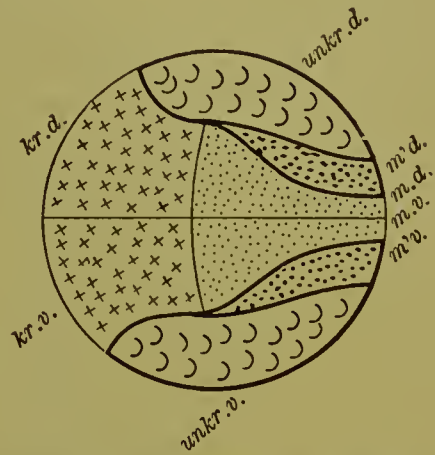
with its base turned towards the pial sheath and its point towards the central vessels. (Figs. 38 and 39.) In Fig. 38 the positions of the different portions are indicated: *kr.d.* shows the dorsal part of the crossed bundle; *kr.v.* represents the ventral portion of the crossed bundle; *unkr.d.* designates the dorsal part of the uncrossed bundle; *unkr.v.* represents the ventral part of the uncrossed bundle; *m.d.* shows the dorsal part of the macular

FIG. 38.



Subdivision of nerve-fibres in the optic nerve.

FIG. 39.



Subdivision of nerve-fibres in the optic nerve.

uncrossed bundle; *m.v.* represents the ventral part of the macular uncrossed bundle; *m'd.* signifies the dorsal part of the macular crossed bundle; and *m'v.* represents the ventral part of the macular crossed bundle.

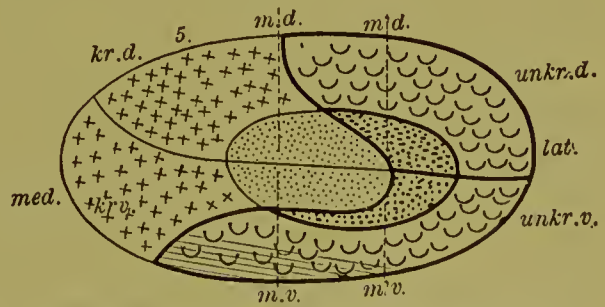
Farther back this bundle is half-moon-shaped. Still farther back it takes the form of an upright oval, and approaches nearer the axis of the

FIG. 40.



Subdivision of nerve-fibres in the optic nerve.

FIG. 41.

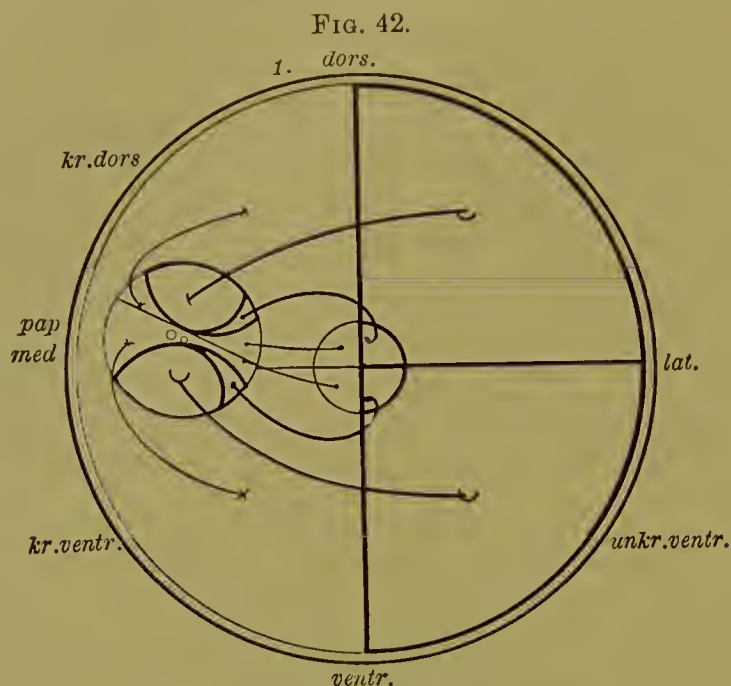


Subdivision of nerve-fibres in the optic nerve.

optic nerve. In the optic foramen it assumes an axial position. (Fig. 40.) In front of the chiasm it assumes the form of a horizontal oval. (Fig. 41.) The macular bundle contains crossed and uncrossed nerve-fibres. In front in the papilla the crossed fibres lie ventrally and the uncrossed ones more ecentrically, being in proximity to the other uncrossed fibres. The spreading of the fibres over the retina appears as shown in Fig. 42. Farther back the macular fibres become drawn together towards the centre. (Fig.

39.) The dorsal half of these fibres goes to the dorsal half of the retina, whilst the ventrally placed fibres go to the ventral half.

(b) The uncrossed (not the macular) bundle is divided in the anterior division of the optic nerve into two fascicles, a dorso-lateral uncrossed dorsal part and a ventro-lateral uncrossed ventral portion. In the lamina cribrosa these fibres are separated by the macular bundle. Behind the



Subdivision of nerve-fibres in the retina.

entrance of the central vessels the fascicles approach one another and form a united half-moon-shaped bundle, which includes the lateral periphery and lies somewhat ventro-laterally.

(c) The crossed bundle (not macular) forms a closed cord in the whole optic nerve. In the papilla it is situated dorso-medially, and retains this position until it passes the chiasm.

Defects of the visual field in diseases of the optic tract are best divided after Uhthoff's method into three principal groupings: 1. Cases in which the whole optic nerve appears affected by the disease-process, and in which a more or less even diminution of the size and color-perception of the whole extent of the visual field is found. 2. Cases in which more or less clearly defined defects of the visual field, appearing in conjunction with comparatively normal function over the remaining portions of the field, are found. 3. Cases in which an even concentric diminution of the visual field, with good central visual acuteness and good color-vision in the preserved portions of the field, is found, and in which a comparatively normal condition of the macula and the nerve-fibres in its immediate neighborhood is recognized.

In a case of multiple sclerosis seen by Uhthoff,<sup>1</sup> the upper part of the

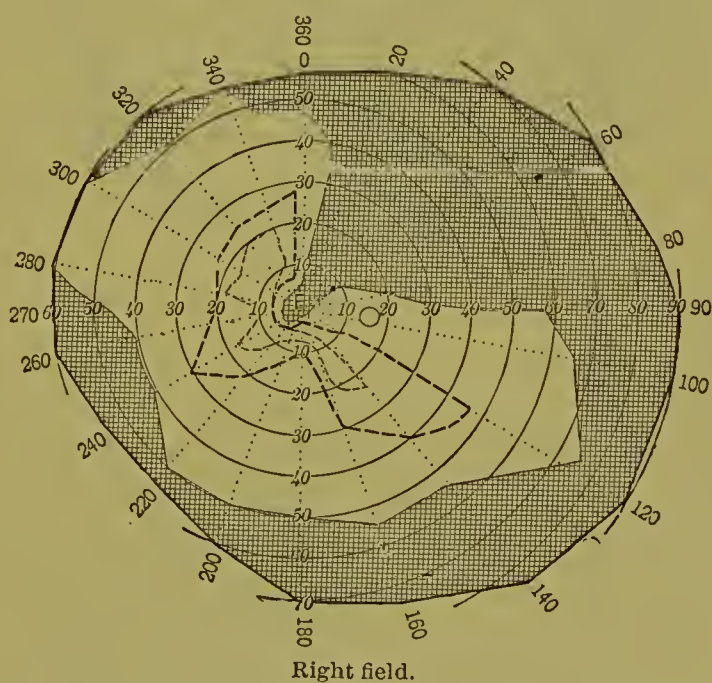
<sup>1</sup> Archiv für Psychiatric und Nervenkrankheiten, xxi. 318.



field of vision showed a color-defect, which in time disappeared and gave place to a ring scotoma. The disturbance of vision developed suddenly in this eye, whilst in the other it appeared very slowly. In optic atrophy, a ring-shaped portion of the field surrounding a central scotoma, in which perception is good and outside of which the field is deficient, may be more frequently met with than ring scotoma. This, however, is but a temporary condition in an inevitable lessening of visual power.

Passing to the consideration of the separate series of defects of the visual field in diseases of the optic nerves, the first grouping is reached. Here the central visual acuteness continuously decreases during the shrinking of the sector-shaped or irregular areas in the peripheral zone of the visual field. In the remnants of the field which remain active a decrease of function can be recognized by the great lessening of the color-fields,—the

FIG. 43.

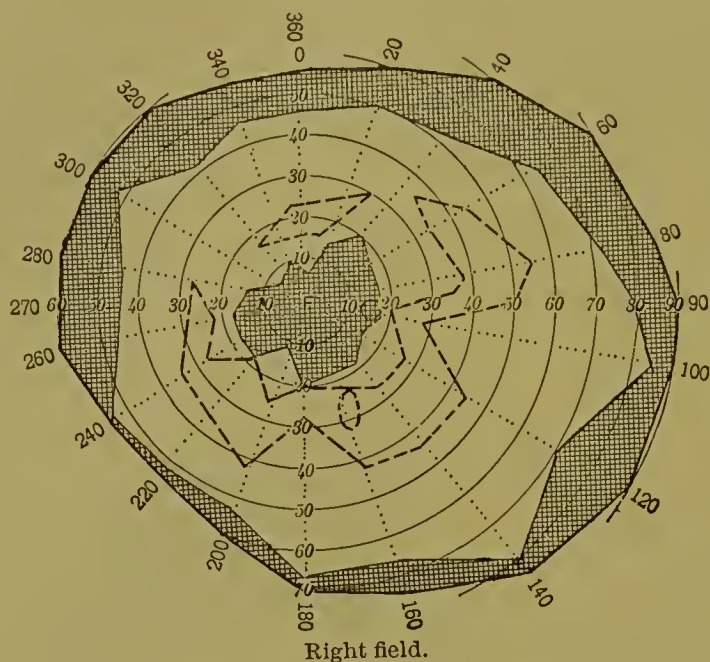


first to disappear being green, then red, and lastly blue. (See Figs. 33 and 34.) In extremely rare instances red disappears before green. After the appearance of complete color-blindness, a small portion of the field for white remains, situated either at the centre or more frequently in the nasal half of the field. (Fig. 35.) At times the sector-shaped encroachments extend beyond the fixation-point in such a way as to interrupt central fixation. (See Fig. 43.) Such fields prove that the atrophic processes are more or less evenly distributed over the whole area of the visual nerve-fibres, even though, as shown by the presence of the deep sector-shaped defects and the larger deficient portions of the visual field, separate areas are much more severely disturbed than others. (Compare Figs. 33, 34, 35, and 43.) Such visual fields are generally found in true primary atrophy of the optic nerves and in spinal atrophies.

In these cases it has not yet been decided from which side the shrinking

commences. Many authors assert that the outer half is first attacked, and that it shrinks the more. Occasionally symmetrical defects are found. Some types, which are found usually among young men, differ from this course in that with the commencing absolute central scotoma the periphery of the field becomes evenly diminished. (See Fig. 44, which represents the

FIG. 44.



visual field of the right eye of the same patient whose left field is represented in Fig. 9.) Here vision rapidly decreases and the ophthalmoscope shows atrophy of the papilla. Later the central scotoma extends in one direction to unite with the peripheral defect at this point, which has increased rapidly towards it, causing the remaining portion to assume a half-moon shape. (See Fig. 9. This condition is also indicated by the color-blind zone shown in the upper part of Fig. 44.) Before the development of complete blindness, which occurs in this type of cases without exception, a small remnant of a color-blind area of vision usually remains in the intermediate zone of the original visual field.

The second group of cases includes all those in which more or less clearly defined defects of the visual field appear and accompany a comparatively normal function of the other portions of the field.

In *sector-shaped* defects with partial atrophic appearance of the disk, the optic nerves are only partly attacked by the disease-process. The classic case by Uhthoff<sup>1</sup> showed a clearly defined defect in a tabetic subject. In this instance the limits for the colors nearly coincided with those of white light. Pathologically there was primary atrophy. The process, which ordinarily attacks the whole optic tract, was circumscribed into a distinct group of nerve-fibre bundles, which were destroyed, the remaining ones being normal. Such cases are, however, extremely rare.

<sup>1</sup> Archiv für Ophthalmologie, xxxii. 181.

In cases of defects in which *the visual field is more or less diminished on one side only, accompanied by retention of color-vision in the rest of the field, with good central visual acuteness, there may be either a normal condition, a more or less widely spread neuritis, or a simple atrophic fading of the disk (descending atrophy). All of these cases, however, are caused by*

FIG. 45.

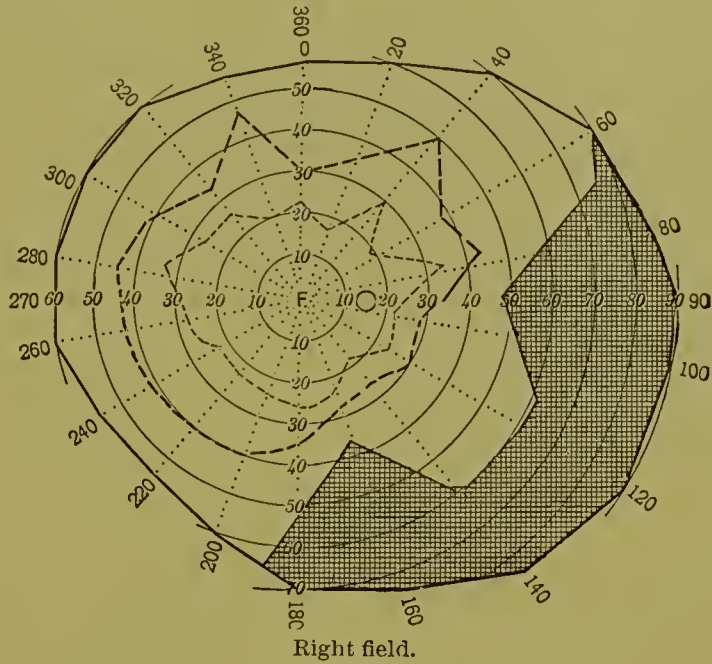
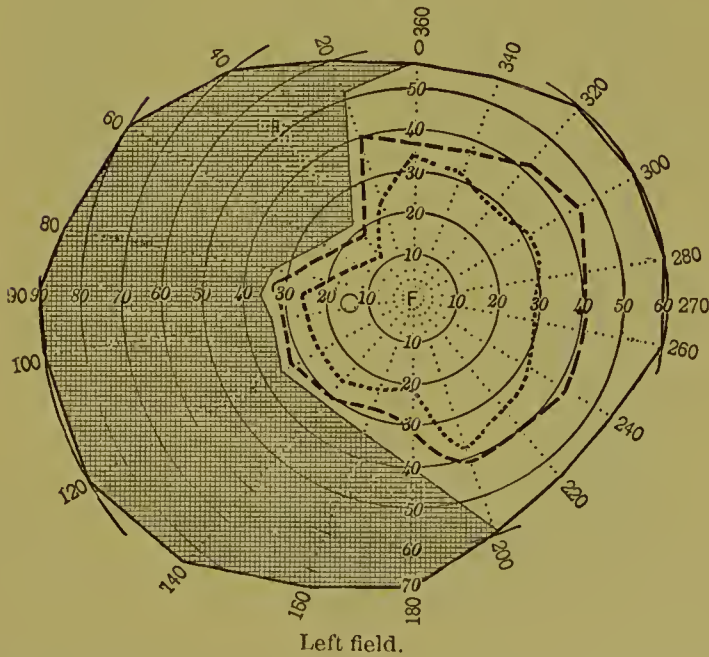


FIG. 46.



inflammatory processes that are mostly situated far back in the optic nerve tract. The recognition of the condition, which, unfortunately, is often mistaken for progressive atrophy of the optic nerves by those who are not well grounded in the art of perimetry, is of the utmost importance, because, when it is properly diagnosed in time, the power of vision may be preserved by energetic antipllogistic measures. The author has frequently

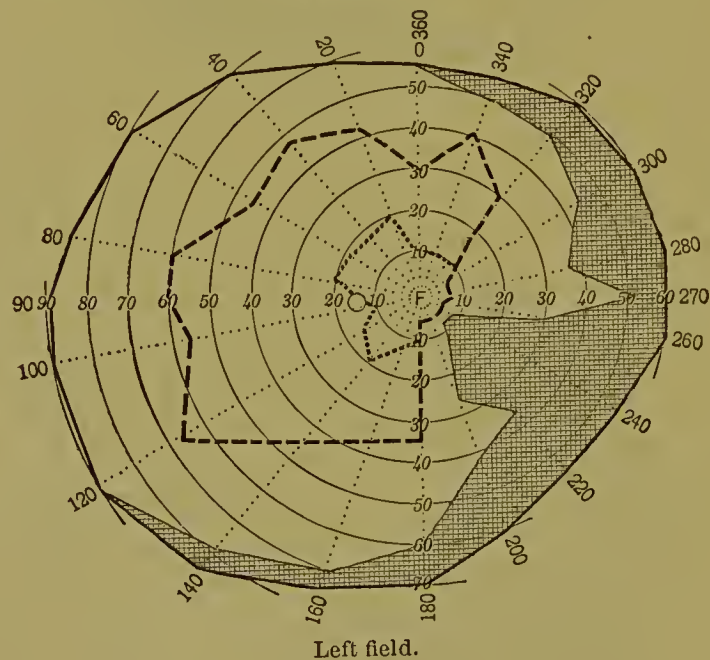
observed such cases among those suffering from syphilitic spinal affections, and has noted examples which exhibited conditions similar to those of tabes, and in which a marked improvement occurred after the energetic use of inunctions of mercury.

In simple progressive atrophy of the optic nerves the use of inunctions of mercury is rightly prohibited; in those cases, however, which are often so similar to tabes, mercurial inunctions are especially to be employed.

Figs. 45 and 46 represent an otherwise perfect field in which at one side there is a marked defect that is accompanied by a narrow margin parallel to the limits of the color-field, in which color-perception is lost. In these cases the central acuity of vision was normal or nearly so. They were taken from syphilitics suffering from symptoms simulating tabes. In both the disease-process was markedly improved. In the case represented in Fig. 45 the visual field was completely regained.

Fig. 47 shows an analogous case of a syphilitic patient without any other nerve-symptoms. At first an optic neuritis occurred. After ener-

FIG. 47.



getic use of mercurial inunctions the disease-process was brought to a complete stop. The figure shows the visual field a year and a half after the commencement of the disease.

Where two or three quadrants of the fields of vision are alone defective, and the ophthalmoscopic signs which are caused by the same pathological processes greatly resemble those of the previous group, the cause will be found to be a basal gummatous meningitis which has attacked the intracranial portion of the optic tract and has spread as a perineuritis in different degrees towards the eyeball. Uhthoff has been able to observe microscopically three such cases with atrophy of the disk. In them he

found a clearly defined neuritis of the optic tract, with a descending neuritic and perineuritic process in the orbit, continuing as far as the eyeball as a descending atrophy. He also determined that the actual inflammatory changes of the optic nerve and its sheath had already ceased in the hinder part of the orbit. These cases, which seem to pass under the classification

FIG. 48.

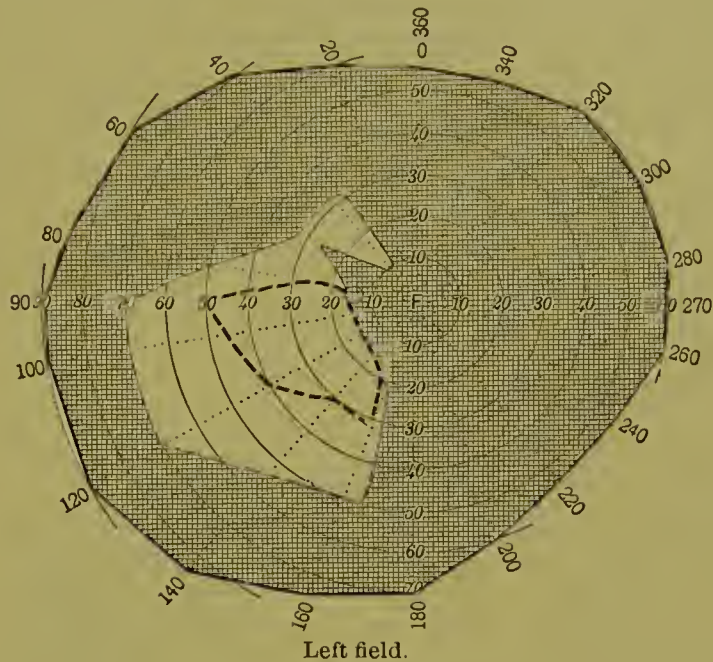
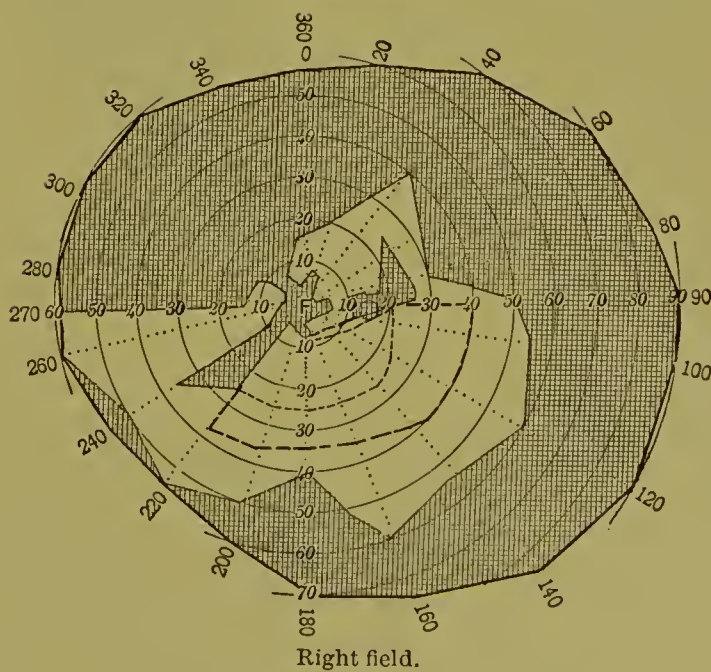


FIG. 49.



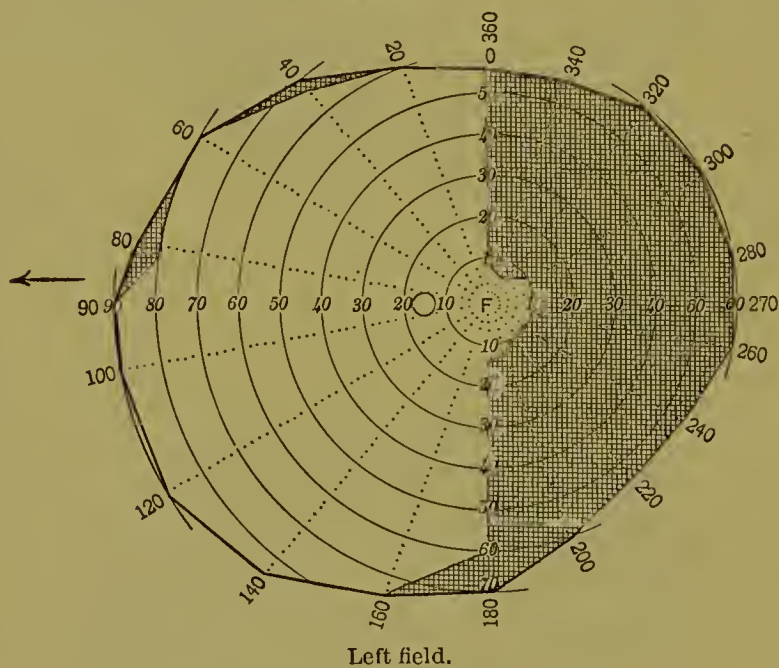
of simple optic atrophy, must always be regarded as secondary to the disease-process, which is situated far back in the optic tract.

Figs. 48 and 49 represent the visual field of the left and right eyes of a man aged forty-eight years, who in childhood suffered from a cerebro-spinal meningitis, and, with the one exception of an attack of pneumonia, never

had any subsequent illness. He had constantly suffered from this trouble of vision as long as he could remember. It is evident in this case that the defect was caused by a descending neuritis following the basilar meningitis. The ophthalmoscope showed simple white pallor of the disk. The right visual field particularly teaches how such a condition may remain fixed to any one stage after a neurotic disease-process. It is interesting to see how the limits of the individual portions of the color-fields coincided with those of the white field. The lacunal-shaped defect and the lower limits of the scotoma in Fig. 49 point towards partial atrophy of the optic nerve, whilst the inner lower quadrant of the remainder of the visual field, where all color-perception is wanting, evidences the fact that here the corresponding bundles of visual nerves must be markedly interwoven with atrophied nerve-fibres.

Fig. 50 represents the field of a syphilitic patient who suffered from

FIG. 50.



reflex iridoplegia, with loss of patellar reflexes. The right eye was quite normal. The patient observed that three weeks previously there suddenly appeared to be a fog before his left eye. The ophthalmoscope exhibited a marked pallor of the optic disk. The field shows that there must have been a disturbance which produced a partial destruction of the function of the nasal half of the left visual field (which is almost hemianopia in form). Although the temporal half showed normal boundaries when examined with the white five-millimetres-square object, yet color-perception in this area was obtained only by using large surfaces. The diagnosis in this case was a gummatous condition of the intra-cranial part of the left optic nerve, close to the chiasm, where the fasciculus cruciatus and the fasciculus non-cruciatus appear as separate tracts.

In Uhthoff's classical work, a case in which there was not only a

sharply defined boundary for both color and white up to the defect, but in which all the other boundaries were identical, is mentioned. In this case partial atrophy was present.

Frequently in cases of retrobulbar inflammation of the optic nerves the growth of a *central scotoma*, either by itself or combined with a peripheral shrinking of the field which assumes the most diverse forms, may be observed. Sometimes in retrobulbar disease temporary blindness appears rapidly, and on recovery a central scotoma of larger or smaller extent is noticed. Often the remaining portions of some such fields (isolated spots in a peripheral ring-like area) indicate that the condition originated in a central scotoma.

With the exception of those which have been described in Figs. 9 and 44, central scotomata are never found in *primary* atrophy of the optic nerves. A central scotoma should always be suspected in a patient who, with a great diminution in central acuteness of vision, has full power of orientation, and had good vision in the affected eye before the onset of the disease. Such scotomata may appear at once as absolute, or primarily for color alone.

The appearance of a scotoma of a lengthened oval shape in the red and green colors is, according to some, pathognomonic of *toxic amblyopia*. In studying such scotomata it is essential, however, to use objects only one or two millimetres square.

If it be desired to compare the size of the fault in the visual field with the extent of the atrophic portion of a cross-section of the optic nerve in a microscopic specimen, it is best, as previously noted, to examine the visual field with the smallest possible colored objects.

At the commencement of the appearance of a central color-scotoma a weakening of saturation of green and red is observed. The tones of these colors show a change, in the fact that gray appears more pronounced. In the blue field no scotomata can be found. Later red disappears and blue becomes slightly faded. Finally white, in a small spot of the scotoma, cannot be perceived, or appears to be darkened. At this stage the absolute defect is surrounded by a color-blind zone, beyond which vision for blue is present, followed by red and green. Thus the scotomata, to a certain extent, seem to lie inside one another, that of green being the largest, that of red a little smaller within it, followed by blue showing a similar relation to the red, and lastly by the smallest of all, the scotoma for white, in the centre.

In diseases attacking the papillo-macular bundle of nerve-fibres, where the periphery of the visual field is undisturbed, it may be considered, perimetrically, that the condition of the disease is progressive only under the following circumstances: first, when an examination with large examining objects shows the extent of relative and of absolute scotoma to be the same; second, when the limits of the scotoma remain the same during examination with similarly-sized white or blue surfaces, whilst the extent of the scotoma is increased when a similarly-sized red surface is employed; third, when the

extent of the red field remains unaltered, yet inside the scotoma a defect which was not previously present is found during an examination with a white object of any size ; fourth, when a scotoma in the field of white is present, a similarly-sized object for red or blue is used, and it is found that only the remnants of the color-fields remain (or when colors are found successively disappearing from the visual field).

FIG. 51.

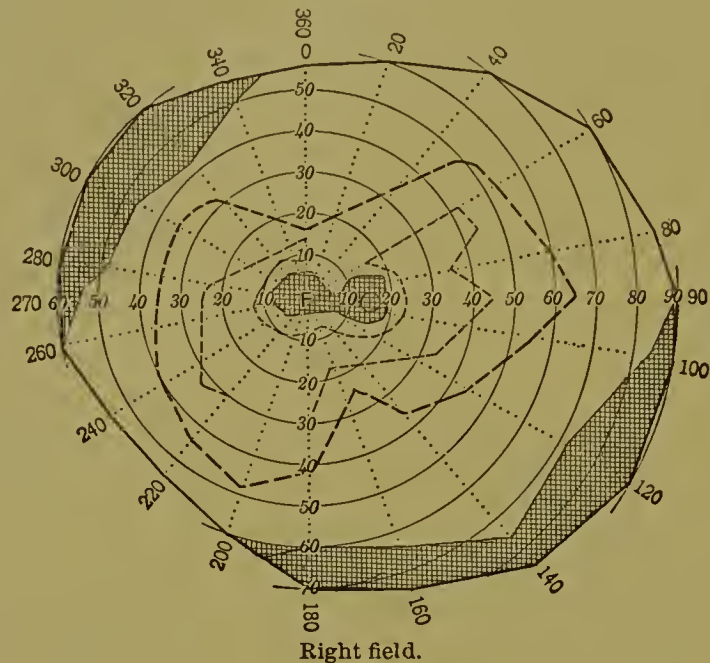
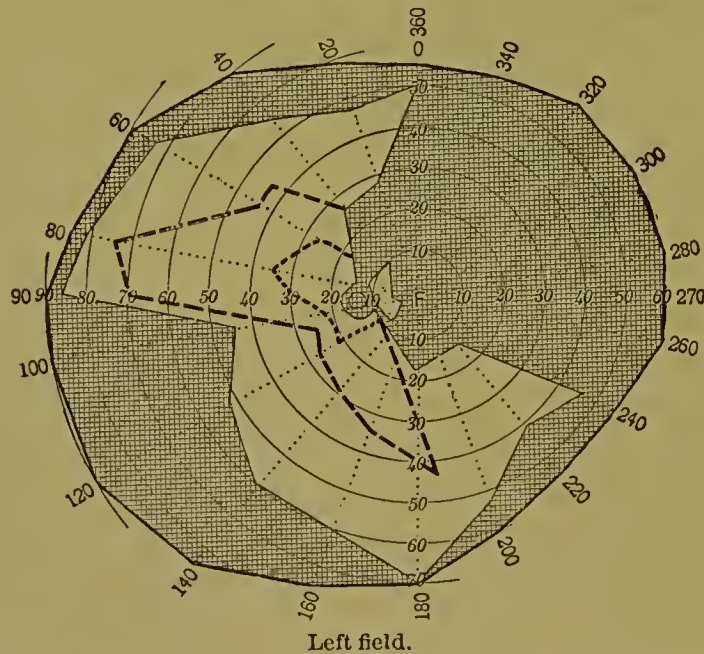


FIG. 52.



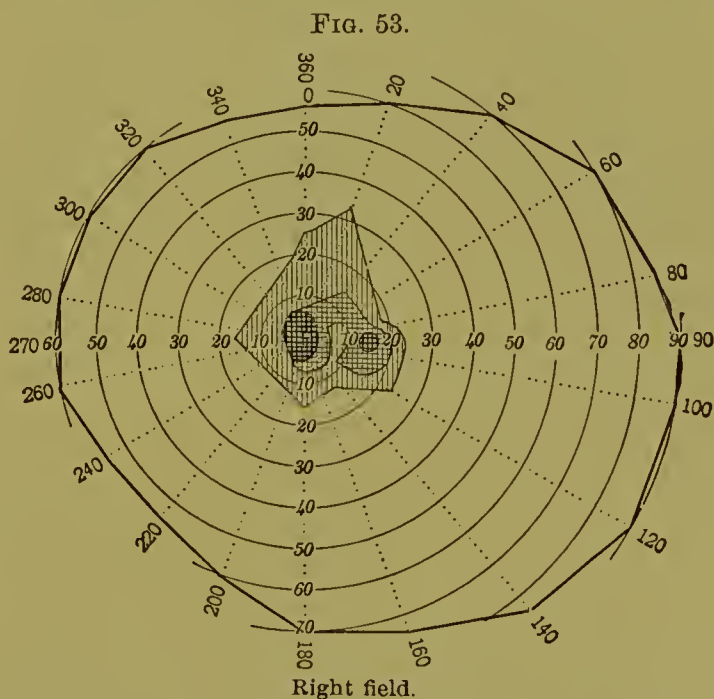
The condition should be regarded as retrogressive, first, when the sizes of central defects of the fields of red and blue remain unaltered, whilst the scotoma for white decreases in size ; secondly, when a color-blind zone encircling an absolute defect grows narrower ; thirdly, when a single red defect decreases in extent.



In all stages of *central scotomata* which are caused by inflammatory processes, the development of the process, and hence the condition of the visual field defects, may become stationary. Figs. 51 and 52 show such a case, of fifteen years' duration. Ophthalmoscopically, the inner sides of the papillas contained reddish bands of nerve-fibres arranged in the form of a half-moon.

A central scotoma alone, even if it has been absolute, may disappear and the sight return completely. When combined with a peripheral shrinking, it may lead to absolute blindness. Long-standing cases, in which primarily the ophthalmoscope shows that the fundus is normal, will later evidence a white discoloration of the temporal half of the disk.

Among the many forms of central scotoma caused by a *chronic retrobulbar neuritis*, special mention should be made of a type that is distinguished from others by the general clinical symptoms. This group consists in, first, that form which is described by Förster, and which the author has



also studied, as *neuritis axialis*;<sup>1</sup> secondly, a retrobulbar neuritis dependent upon *heredity*; and, thirdly, the *chronic amblyopia of intoxicants*. All three forms show that both eyes are affected, and that young males are especially prone to the condition.

If the field of vision in a case of axial neuritis be examined with a one-millimetre-square white object at the commencement of the disease, usually a small scotoma at the point of fixation will be found. At the same time close to it there will be an enlargement of the blind spot. Slowly these spots will unite either above or below (see Figs. 53 and 54), so that the visual field for *white* assumes the shape of a horseshoe. Later the scotoma spreads and encloses the fixation-point, the blind spot,

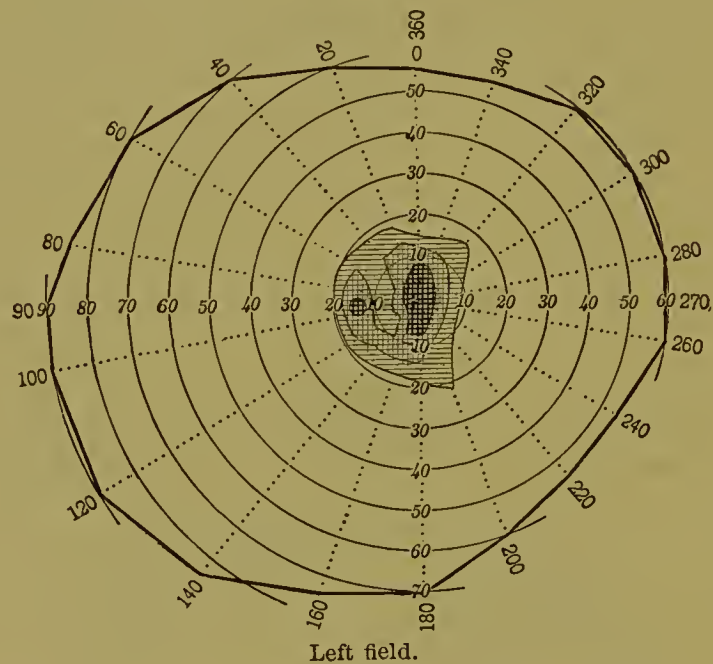
<sup>1</sup> Klinische Monatsblätter für Augenheilkunde, 1878.

and a large portion of the central visual field. (See Figs. 53 and 54.) The periphery of the field generally remains normal.

This form of field is ordinarily seen in cases of hereditary retrobulbar neuritis. Here the central scotomata commonly occupy a larger area. At times the periphery may exhibit a marked shrinkage in several directions. In a case of this kind recorded by Ulthoff<sup>1</sup> there remained at last on both sides of the visual field only half-ring-shaped zones extending towards the lower part of the field. In one of Jever's cases<sup>2</sup> the visual field recovered, so that only a small relative scotoma for green remained, lying close to the fixation-point. Recovery is, however, of rare occurrence.

A central scotoma is relatively often met with in *multiple sclerosis*. Still, it is seldom so absolute in these cases that a white object is lost in the

FIG. 54.



scotomatous area. In most cases the defect is present as a color-scotoma, or one causing uncertainty in the area where colors seem darker than normal. Often it appears suddenly to vanish, followed, at times, by alterations in the periphery of the field. Such scotomata may be easily overlooked, because, even if very small examining surfaces are used, the colors only assume a darker hue, or appear as if covered with a fog.

The visual-field symptoms of chronic intoxication-amblyopia caused by the abuse of tobacco and alcohol are distinctly separated from all other forms of field-defect found in retrobulbar neuritis. There is an elongated oval defect for red, situated between the fixation-point and the blind spot, the outer boundaries of the field being intact. In examining such a field, small colored surfaces five millimetres square or less should be used,

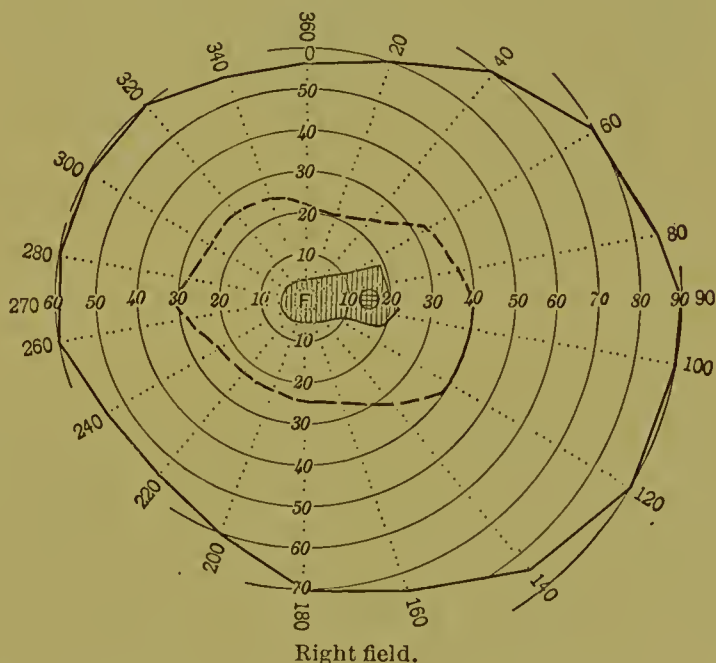
<sup>1</sup> Beiträge zur Pathologie der Sehnerven und der Netzhaut, Berlin, S. 37.

<sup>2</sup> Zur Symptomatologie der eigentlichen, nicht durch Intoxication bedingten retrobulbären Neuritis. Dissertation, Berlin, 1887.

because often a scotoma cannot be demonstrated by a larger object. Ordinarily, in the scotomatous area a red object appears gray or dark gray. When the disturbance is less intense the red color appears yellowish, and if the disease-process be slight it may assume a faint or dark red tint. White shows in the defective area as either "less clear" white or gray. The defect is not sharply defined round the edges, but passes gradually through a zone of diminished perception to the intact part of the field. The size of the defect, therefore, often depends on the judgment of examiner and patient.

At the beginning of intoxication-amblyopia a small defect for red color is found situated external to the fixation-point. Should it spread to the fixation-point, it does so to only a trifling degree. The color-scotoma is invariably present in both eyes, and seems to appear on one side in the new cases. The blind area for red is increased on both sides equally to eight or ten degrees, though intelligent patients may assert that even in the portion

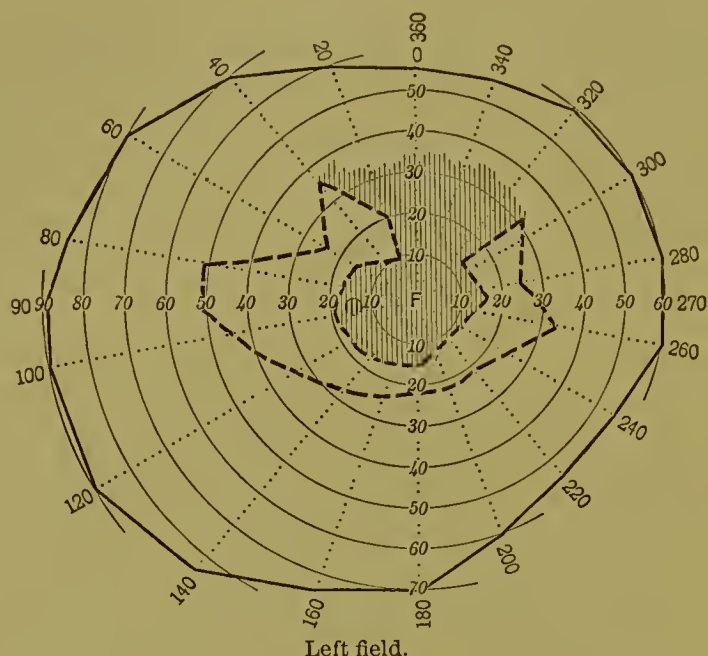
FIG. 55.



where red is still perceived (between the point of fixation and the normal blind spot) they cannot perceive the red object so clearly as they can when it is situated inward from the fixation-point or outward from Mariotte's spot. If the disease becomes more pronounced, the two defects at the fixation-point and the blind spot increase (as in Figs. 53 and 54) towards one another, leaving a narrow bridge between them. Finally they unite. This union, however, does not usually occur in the direct line joining the fixation-point and the blind spot, but, like that seen in Figs. 53 and 54 (in cases of neuritis), shows that they unite either above or below in such a way that a peninsula of red-perception extending from above or below into the horseshoe-shaped defect is present. Sometimes an island in which red-perception is present remains, surrounded by a ring-shaped defective

portion of the field. (Compare Fig. 52, in which the defect of the inner upper quadrant has developed from a central scotoma in a case of axial neuritis.) This area also disappears, so that the defect assumes the form of a horizontal oval. (See Fig. 55.) At the same time the peripheral limits for red remain normal. The egg-shaped defect for red does not increase equally all round, but at first enlarges in an upward direction, until it reaches the limit of red-perception, giving rise to the saying, "The defect has broken through upward." (See Fig. 56.) Occasionally the increase

FIG. 56.



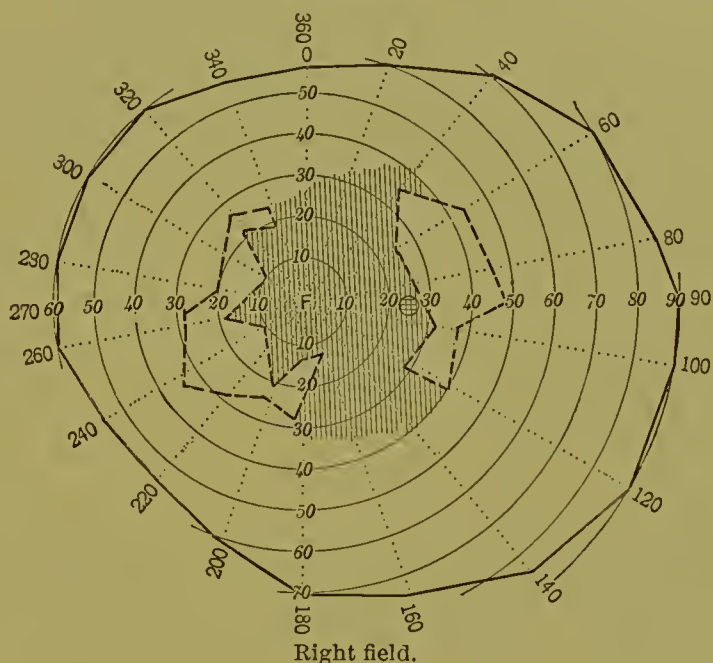
of the scotoma causes a drawing in of the bounds for red of the outer edge of the visual field, so that the narrow bridge of red which lies between them is broken through. If the defect continues to extend through the entire region where red is perceived, it next breaks through downward, so that the visual field for this color is divided into two halves. (See Fig. 57.) Later red is preserved only in an area situated inward from the fixation-point in the region of the uncrossed fasciculus. Finally the last remnants of red fade, leaving the patient only the ability to distinguish between blue and yellow. The phases of loss for the green field exhibit the same peculiarities as do those for red. This acquired variety of color-blindness is distinguished from the congenital form by the marked diminution of central visual acuteness.

Uthoff's experience<sup>1</sup> has shown that but two among one hundred and thirty-eight cases showed a large central absolute scotoma surrounded by a wide blue-blind zone. The writer can add his testimony to this assertion. In his cases red and green were unrecognized. This ending to a tobacco and alcohol amblyopia is rare. According to Uthoff, even those cases in which the perception of red and green is lost may recover. In uncon-

<sup>1</sup> Archiv für Ophthalmologie, xxxiii. 257.

plicated cases the outer margins of the field remain normal throughout the continuance of the disease, but there may be a coincident concentric shrinkage as the result of an intercurrent functional nervous disturbance; a condition that is of importance when field-defects are compared with the microscopic findings of cross-sections of the optic nerve. The termination of intoxication-amblyopia (which is invariably binocular) in by far the greater number of cases is a more or less complete recovery, with return of the fields of vision. In others the defects remain unaltered. Rarely

FIG. 57.



the condition passes on to atrophy of the optic nerves, with progressive peripheral shrinkage of the field limits.

Bunge<sup>1</sup> and Sachs<sup>2</sup> have shown that the position of the typical oval scotoma, lying as it does eccentrically and to the outer side of the fixation-point, becomes of prominent importance in that in the corresponding parts of the retina the finer qualities of the visual sense are often destroyed. During the period of recovery the last remnants of the scotoma may be demonstrated when the centre suffices for all demands, as regards color- and space-sense, that ordinary clinical methods of examination require. This area, called by Sachs the "corespace," extends in a horizontal direction from one or two degrees to about eight degrees laterally from the fixation-point. Its extent of vertical direction generally nearly coincides with the horizontal. In this space it is easiest for small absolute scotomata to appear, and it is the situation in which the scotomata shrink as they gradually lessen during the stages of recovery from amblyopia. The area itself is situated between the fixation-point and the peninsula already alluded to, giving the scotoma its horseshoe shape during the beginning of the disease.

<sup>1</sup> Ueber Gesichtsfeld und Faserverlauf im optische Leitungsapparatus, Halle, 1884.

<sup>2</sup> Archiv für Augenheilkunde, Bd. xviii. S. 42.

Uhthoff calls attention to this space.<sup>1</sup> As there may be a visual acuteness of  $\frac{6}{8}$  at the centre of the field, and yet a small red object completely disappear at this point, Bunge, in order to make a rapid diagnosis of such a color-scotoma, places two red surfaces on the bow of the perimeter, so that one is eight degrees on the nasal side and the other the same number of degrees on the temporal side of the fixation-point. This done, he makes the patient simultaneously compare the two color-areas whilst central fixation is carefully preserved.

The lateral position of the "corespae" also demonstrates the almost constant observation that the right eye finds difficulties in reading print, which runs together, because a large part of the letters of a long word falls on this space of the scotoma. Hence also can be understood why there should be difficulty in seeing near objects when distant ones are distinct. Moreover, it can be seen, on account of the lateral position of this space, why vision in the left eye fails in passing from the end of one line to the beginning of another when reading, and often for the first letter of a word.

Though an oval-shaped defect with its long diameter lying transversely includes the fixation-point as well as the blind spot, yet the former area is ordinarily covered in a minor degree inward. The defect is less noticeable in binocular vision, because the central healthy halves of the visual fields cover the greater part of the temporal portions of the scotoma and thus form a useful field. In consequence of this slight inclusion of the fixation-points, there remains only a small scotoma close round the fixation-point in the binocular field. For this reason even watchful patients commonly overlook the commencement of the disturbance, through not testing their own monocular visual power.

Physicians with little experience may be tempted to mistake a central scotoma of intoxication-amblyopia for a temporal hemianopia one. In order to differentiate between the two conditions it must be borne in mind that in temporal hemianopsia the scotoma always extends to the fixation-point, while in the scotoma of intoxication-amblyopia it extends inward over the fixation-point, usually only slightly, in all meridians.

Uhthoff<sup>2</sup> has shown from those cases which he was able to examine microscopically that there are always some nerve-fibres which remain healthy among the diseased ones of the papilla, even where the disease is most intense, a condition which is observed only at the outer edge of the affected parts of the nerve in primary atrophic processes.

This partial retention of small retiform spaces with healthy nerve-fibres in the midst of a marked degree of interstitial change is peculiar to those alterations of the visual nerves which are caused by alcohol.

The field of vision in diseased conditions of the nerves behind the

<sup>1</sup> Archiv für Ophthalmologie, xxxiii. 1, 307.

<sup>2</sup> Ibid., xxxii. 3, 4, 146.

eyeball can give no direct answer to the question as to where the primary seat of the disease is to be regarded as situated in the whole course of the optic tract. If much disturbance of vision has been present for a long time before the slight inflammatory changes at the papilla can be recognized with the ophthalmoscope, this indicates a point of origin of the trouble far back from the eyeball. Hock believed it necessary to locate the point of origin of the disease in the optic canal in such cases, because in acute retrobulbar neuritis pain is frequently felt when the eye is moved or pressed into the orbit. An inflammation of the dura mater (which acts as periosteum in this canal) spreads along the pial sheath of the optic nerve and thus causes a secondary neuritis. The swelling following this inflammation then presses on the whole optic nerve, and thus the papillo-macular fibres, which are here situated in the centre, are hindered in their function. The peripheral defects of the visual field would at the same time correspond with those portions of the conducting optic nerve fibres which are nearest to the pathological process in the sheaths.

Uhthoff<sup>1</sup> has made investigations in the neuritis of the papillo-macular nerve-fibre bundle in cases of intoxication-amblyopia, which show that the process in the optic canal has also its point of exit behind the eyeball.

### III.

This group includes all those cases in which concentric shrinkage of the field with good central visual acuteness and color-perception over those portions of the field which remain active is found. In this variety of disturbance it must be assumed that there is a relatively normal condition of the nerve-fibres passing to the macula lutea and its neighborhood.

Very few of these cases have been described up to the present time. Uhthoff<sup>2</sup> has pictured and described three such instances, and the author is able to add two cases from his own observations.

Uhthoff has demonstrated by microscopic examination that in this disease there is an interstitial-neurotic process which has spread from the innermost sheath of the optic nerve and covered its whole trunk, enclosing and compressing its outer portions, thus causing a secondary atrophy of the nerve-fibres, so that only its central portions are healthy or relatively so.

Figure 58 represents the left field of a case of tabes dorsalis. The condition developed very suddenly, and remained stationary.

It should be regarded as a rule in *progressive atrophy* of the optic nerves to find a positive ophthalmoscopic change with the characteristic retreat of the color-limits from the periphery, and commencing shrinkage of the visual field limits.

A high degree of concentric diminution of the field with good central

---

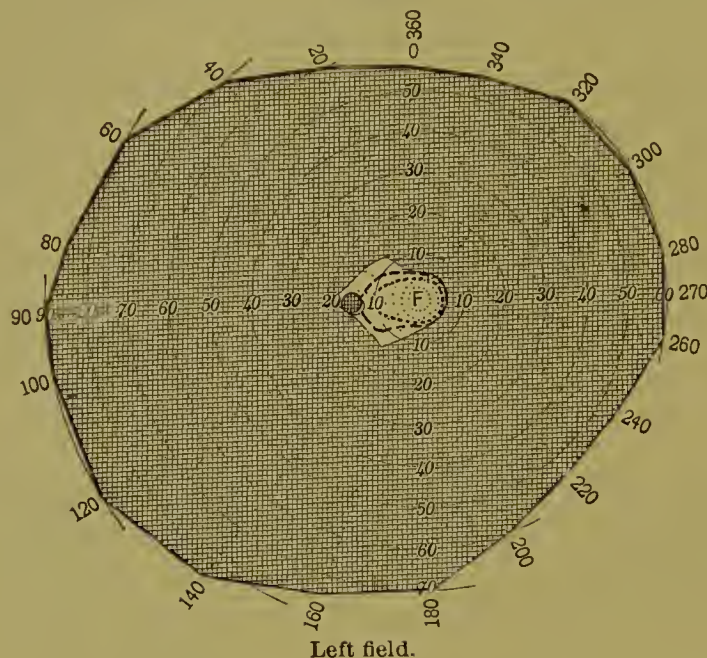
<sup>1</sup> *Loco citato.*

<sup>2</sup> *Opere citato, p. 255.*

visual acuteness and color-perception, and the retention of a small part of the field situated at the periphery, ring-shaped portions of the field, or the appearance of a central scotoma with free periphery of the visual field, are symptoms of the utmost rarity in progressive atrophy of the visual nerves.

Syphilitic diseases usually appear as perineuritis and neuritis descendens, as von Graefe described them. The intra-cranial part of the optic tract is chiefly affected, and the disturbance consists in an increase of its volume (interstitial gummatous neuritis). A central scotoma is a relatively unusual disturbance of the field of vision. While syphilitic retrobulbar neuritis

FIG. 58.



is distinguished from the other forms of retrobulbar neuritis by the rarity of the occurrence of central scotoma, yet it must be remembered that certain analogies exist between the visual disturbances of disseminated foci of sclerosis and those of cerebral syphilis. Hemianopic defects of the field of vision are unusual in disseminated sclerosis.

According to the form of the defects in the field of vision, *multiple sclerosis* may be divided into the following groupings:

1. The anomaly of the field of vision consists in the appearance of a central scotoma with a normal periphery field in one or both eyes. The scotoma is seldom absolute. Usually it is one for green and red, less often for green, red, and blue. Very often it is simply an indistinct one in which the colors are darker or altered in color-tone.

The peripheral portion of the field may remain good whilst green or red and green either are not seen or are recognized only as separate spots. Blue is also recognized in only small parts of the field. The limits of the color-fields alone are concentrically decreased.

2. There are central scotomata combined with diminution of the periphery of the field of vision which attack one or both eyes.



3. The visual field has a periphery which is more or less irregularly shrunken, with relatively perfect central vision.

4. There is regular general concentric diminution, caused by a purely functional condition.

Stress must be laid also on the sudden onset and the equally rapid disappearance of defects in the field of vision, on the fluctuation and alternation from one eye to the other, and on the sudden change in the same eye from a central scotoma to a peripheral diminution.

In Table II. the chief primary atrophic and neurotic diseases of the optic tract are contrasted with one another, in order to give in condensed form a *résumé* of the chapter on the diseases of the optic tract, as well as to assist in the differential diagnosis by direct contrast of the separate diagnostic indications and the different forms of their appearance.

TABLE II.

**TRUE PROGRESSIVE ATROPHY OF THE OPTIC NERVE.** This is rarely idiopathic. *Bilateral.*—Always bilateral. The onset may occur in one eye or in both eyes at once. *Age.*—From eighteenth year upward. *Sex.*—Both sexes suffer, but the male cases preponderate. *Ophthalmoscopic Diagnosis.* White or grayish paling of the disk. Atrophic cupping of the disk. Vessels usually somewhat shrunken. Paling of the disk always present at commencement of visual disturbance. *Field of Vision.*—Concentric and often irregular shrinkage of the field, with defects which enter deeply into the field and are often sector-shaped. Early reduction of the limits of color-vision, with the disappearance of the colors from the field in this order: first green, then red, lastly blue. Central scotomata are present only in conjunction with an evenly spread peripheral shrinkage and a high degree of diminution of color-perception. At the onset of the disease the extent of the field of vision for white light may be normal, whilst the fields for color-vision are already markedly smaller. *Visual Acuteness.*—Usually decreased at the beginning of the attack. Seldom relatively good, with marked concentric diminution. In the latter cases the fields for color-vision are all retained. *Pupils.*—Dilated. Slow contraction to light: *Course of Disease.*—Creeping onset, steady increase. Sometimes a passing halt in the progress for a time. Usually two or three years after the onset of the disease blindness results. *Pathological Anatomy.*—Primary degeneration of the nerve elements in the optic nerve tract. Degeneration in large degree of the non-medullated nerve-fibre tracts in the papilla and in the retina.

**PROGRESSIVE ATROPHY OF THE OPTIC NERVE IN SPINAL NERVE AFFECTIONS, TABES, AND DEMENTIA.** Present in from fifteen to eighteen per cent. of tabetic cases. *Unilateral.*—As in true progressive atrophy. *Age.*—Usually between twenty-eighth and forty-fifth years. *Sex.*—Males preponderatingly attacked. *Ophthalmoscopic Diagnosis.*—As in true progressive atrophy. *Field of Vision.*—As in the true idiopathic form. Very rarely a partial atrophy is present, where the defect is sector-shaped and as if cut with a chisel, the limits of the defect coinciding accurately with those of the color-fields, which are equally clear-cut. The condition is stationary. An isolated central scotoma is rare. *Visual Acuteness.*—As in true idiopathic optic atrophy. *Pupils.*—Unequal dilatation. Irregular, often angular-shaped. Does not react to light. Acts for accommodation. *Paralysis of Eye-Muscles.*—Nuclear paralysis and paralysis of the peripheral muscles of the eye very common, as well as the concomitant condition of optic atrophy, which it often precedes. *Course of Disease.*—The disturbances of vision may precede the tabetic or paralytic symptoms by many years. Blindness almost always results. A partial atrophy is very rare. Tabes with optic atrophy should have a slow and benign course. *Pathological Anatomy.*—Primary degeneration of the nerve elements in the optic nerve tract. Degeneration in large degree of the non-medullated nerve-fibre tracts in the papilla and in the retina.

DISEASES OF THE NERVES OF VISION COMMON IN CENTRAL AND SPINAL SYMPH-

ILIS.—*Unilateral and Bilateral.*—Both. *Ophthalmoscopic Diagnosis.*—In forty per cent. a positive ophthalmoscopic diagnosis. Gray atrophy is never found, because the processes are inflammatory. At first usually negative, because the descending atrophy or neuritis has not yet reached the lamina eribrosa. Simple descending atrophy in fourteen per cent. of the cases. Neuro-retinitis and neurotic atrophy in twelve per cent. of the cases. Choked disk fourteen times in one hundred and fifty cases. Usually bilateral, but sometimes unilateral. Choked disk in one eye, neuritis in the other. Hyperæmia and slight neuritis usual in syphilis. *Field of Vision.*—Constant changes in the condition of the shrinkage in the field of vision. Shrinkage on one side of field of vision only, whilst the rest of the field retains its normal condition. Wedge- and circular-shaped remnants of visual field in the extreme periphery of this field. Concentric diminution of field with relatively good or normal acuteness of vision and retention of all the colors in field. Central scotomata rare, and present only in isolated syphilitic disease of the optic tract. Unilateral blindness, with temporal hemianopsia of the second eye. *Visual Acuteness.*—Variable. Sometimes passing blindness and a high degree of visual disturbance present, with little change observable by the ophthalmoscope. *Pupils.*—Comparative relation to the intensity of the disease. Sometimes reflex immobility of pupil. Deficiency in the pupillary reaction as a result of nuclear paralysis. *Paralysis of Eye-Muscles.*—Often the presence of an involvement of one or more of the nerves of the base of the brain is present. In one hundred and sixty-seven autopsies affections of the optic apparatus = 101, of the oculo-motor nerves = 66, of the abducens = 29, of the superior oblique = 6, of the trigeminus = 25. *Course of Disease.*—Onset of disease subacute. Recovery at any stage of the disease. Frequent variability, particularly in the acuteness of vision and the field of vision. Restitutio in integrum possible. Permanent bilateral blindness very unusual. *Pathological Anatomy.* Usually gummatous meningitis at the base of the brain and syphilitic disease of the cerebral arteries. Strangulation of the nerves of vision by the arteria corpora callosi or by pressure from the carotis interna, where this vessel lies in contact with the under surface of the intracranial optic tract. Less often large isolated gummatous tumors. Descending neuritis with hydrops of the sheath of the optic nerve. Perineuritis with interstitial neuritis, usually of the peripheral nerve-fibre bundles of the optic tract, so that the nerve-fibre bundles which are situated in the centre of this tract remain normal or relatively so. Gummatous degeneration of the intraeranian optic tract. Interstitial inflammation or gummatous degeneration of a separate portion of the cross-section of the optic tract only. Variable conditions of pressure-conducting nerve-paths occasioned by the rapid growth and resolution of granulation-tissue, which constricts the chiasm and the nerves. In addition to this, the tissue which sends its processes between the nerve-fibres is very prone to swell in consequence of the growth of numerous new blood-vessels.

DISEASES OF THE OPTIC NERVES IN MULTIPLE SCLEROSIS.—*Unilateral and Bilateral.*—Often passes from one eye to the other. About half the cases are unilateral and the other half bilateral. *Age.*—From twentieth to fortieth year. *Sex.*—Males usually attacked. *Ophthalmoscopic Diagnosis.*—In about one-half of all cases the diagnosis is abnormal. With a normal diagnosis there may nevertheless be wide-spread disease back in the optic tract. Incomplete atrophic paling of disk in consequence of the retention of part of the axis-cylinders of the papilla and retina. Partial paling of the temporal half of the disk. One can draw no conclusion as to the visual field (central scotoma) from this paling of the disk. Optic neuritis (six per cent. of the cases) usually fugitive in its course, and dependent on fresh sclerotic changes close behind the lamina. *Field of Vision.*—Predominating central scotoma, usually a color, seldom a complete scotoma. Periphery is almost always free. Small ring scotomata very rare. Scotomata of indistinctness common. Change from central scotoma to diminution of periphery of field in the same eye. Disappearance, reappearance, or complete recovery of central scotomata. Also concentric irregular diminution of field as in tabes, and genuine progressive atrophy of optic nerve. Purely functional disturbances are also observed, such as shrinking, and appearances of field following exhaustion. Hemianopsia has not yet been observed. Marked irregularity in the relation of the ophthalmoscopic diagnosis and the disturbances in the field of vision. *Visual Acuteness.*—Well-marked irregularities in the relation between

the ophthalmoscopic changes and the central acuteness of vision, without any demonstrable scotoma of indistinctness. *Pupils*.—Reaction may be still well preserved even where vision is markedly disturbed. *Course of Disease*.—The eye-symptoms may precede other symptoms even by several years. A sudden attack, often with great disturbance of vision. Rapid recovery. Recovery common. Complete blindness very rare. Differential diagnosis of multiple sclerosis and hysteria often very difficult. Remarkable and irregular change in the alterations of the field of vision. *Pathological Anatomy*.—The changes in the optic nerve are usually distributed quite irregularly, and may be scattered over the whole optic tract; meanwhile the ophthalmoscopic diagnosis of the partial temporal or the incomplete atrophic paling of the disk perhaps is caused only by unimportant changes close behind the lamina cribrosa, which do not give rise to any disturbance of vision. There is no tendency to descending degeneration from foci lying farther back in the optic tract. Often there is good preservation of the axis-cylinders in the retrobulbar sclerosed portions, and an almost normal condition of the non-medullated nerve-fibre tracts in the papilla and the retina. The changes in the nerves of vision appear to stand equally between the condition of primary tabetic atrophy and the atrophy of the visual nerves which is consequent on interruption of the conducting path on the one hand, and on the other an actual interstitial neuritic atrophy. (Uthoff.)

**RETROBULBAR NEURITIS NOT CAUSED BY SYPHILIS OR CHRONIC INTOXICATION.**—*Unilateral and Bilateral*.—In this case not so typical. Defects present in both eyes, as in the chronic intoxications. A space of weeks or months may pass before the second eye is affected. *Age*.—Youth is mostly the period of attack. *Sex*.—Males two-thirds, females one-third. *Ophthalmoscopic Diagnosis*.—Normal and optic neuritis, which then usually occurs later. Mostly partial paling of the papillo-macular nerve-fibre bundle. *Field of Vision*.—Predominance of large absolute central scotomata, usually with a clear periphery of the field, or defects in the field, which are the result of the enlargement of central scotomata (partial ring-shaped zones of the field of vision which remain preserved). Also central color-scotomata. Seldom irregular defects extending towards the periphery are present. *Visual Acuteness*.—The visual acuteness shows great variations. It may vary from the reading of small print to complete blindness. A permanent absolute amaurosis is rare. *Pupils*.—The pupil, when the sound eye is covered, is more dilated and moves more slowly than the healthy eye. There is no reflex paralysis. *Course of Disease*.—Sometimes there is pain in back of orbit. Onset sudden; often accompanied by a high degree of disturbance of vision. Rapid improvement. Recovery or arrest and stasis at any stage of development, also complete blindness. Improvement common. *Pathological Anatomy*—Neuritis of the papillo-macular bundle is very common; less often there is interstitial neuritis of special parts of the cross-section of the optic tract. Always descending atrophy towards the papilla, which causes the paling of the temporal half of the papilla.

**NEURITIS DEPENDENT ON HEREDITARY CONDITIONS.**—*Bilateral*.—Always bilateral. *Age*.—Early years. *Sex*.—Chiefly males attacked. *Ophthalmoscopic Diagnosis*.—Atrophic paling of the disk, following the descending atrophy. *Field of Vision*.—Absolute central scotomata of larger or smaller extent, sometimes allowing only half-ring-shaped zones to remain in the periphery of the field. *Visual Acuteness*.—Weakened in a large degree. *Course of Disease*.—The ultimate result is very weak vision; never blindness. Slow course. Recovery not impossible.

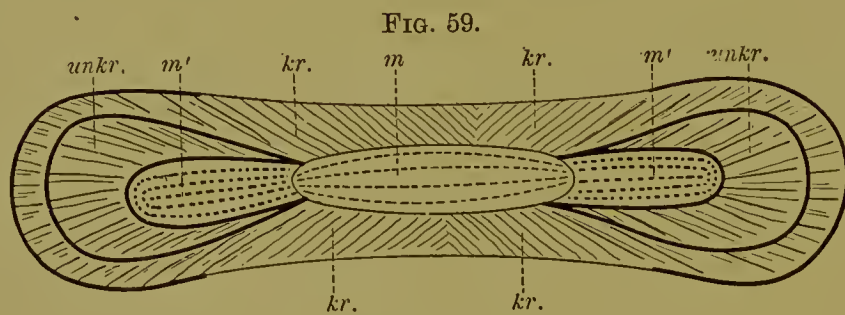
**TOBACCO AND ALCOHOL AMBLYOPIA.**—*Unilateral*.—In one case. *Bilateral*.—Of one hundred and thirty-nine cases one hundred and thirty-eight bilateral. *Age*.—Usually between forty and sixty years. *Sex*.—Males with almost no exceptions. *Ophthalmoscopic Diagnosis*.—At commencement normal, later paling of the temporal halves of the disks. Faint cloudiness of the disk and surrounding portions of the retina. Hyperæmia of papilla. Retinal hemorrhages. *Field of Vision*.—Predominating presence of long, oval-shaped color-scotomata for red and green situated between F and M. Scotomata for blue are rare. Absolute scotomata within the color-scotomata are rare, and, when present, small. Periphery of field of vision unaffected. Complete loss of red-color perception in the field of vision, whilst the extent of the perception of white remains normal. In alcohol poisoning there is also a general, evenly spread concentric diminution of the field resulting

from functional cause. *Visual Acuteness.*—Great weakness in visual acuteness, with no constant relation to the size of the defect in the field of vision. In cases where early treatment can be obtained, complete restoration of sight is usual. *Pupils.*—In alcohol poisoning difference in the two pupils not uncommon. *Paralysis of Eye-Muscles.*—In alcohol poisoning we sometimes find paralysis of the abducens. *Course of Disease.*—Attack bilateral and mostly synchronous. Slow development of the disturbance of vision. Usually recovery or improvement. *Pathological Anatomy.*—A neuritis limited to the papillo-macular nerve-fibre bundle, reaching often in its diverse further spread centrally to the primary centre. Even in those portions which are most virulently attacked there are separate, well-preserved nerve-fibre bundles. Hence the rarity of absolute scotoma. There may be well-marked anatomical changes together with paling of the temporal half of the papilla without any substantial disturbance of the vision.

#### THE FIELD OF VISION AS FOUND IN DISEASES AFFECTING THE CHIASM.

*The Paths of the Nerve-Fibres in the Chiasm.*—The papillo-macular bundle, which reaches the chiasm in the shape of an oval lying horizontally (see Fig. 41), retains its central position until it reaches the chiasm. (See Fig. 59, *m*, *m'*.) Farther back towards the centre of the chiasm it almost reaches the periphery, and here the fibres belonging to the fasciculus eruciatus cross one another (*m'*, *m'*). It sinks once more and lies ventro-centrally in the tract. The crossed fibres of this bundle lie more centrally (*m*), and the uncrossed ones more laterally (*m'*, *m'*).

When a cross-section of the optic tract is made immediately in front of



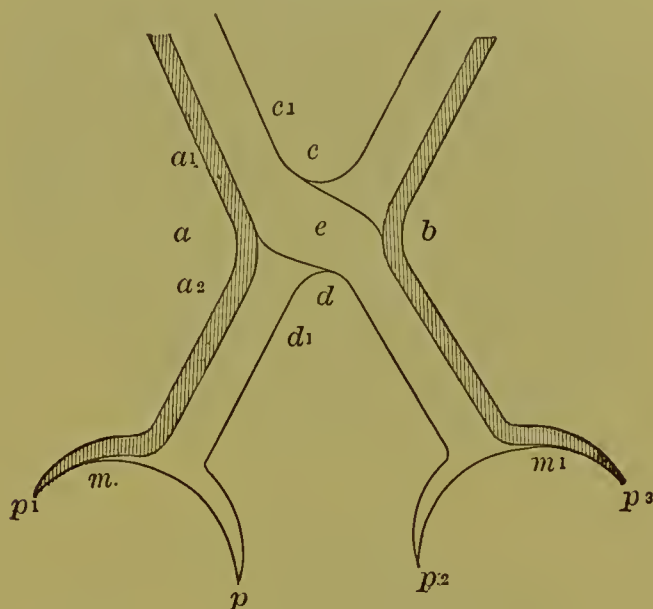
the chiasm, it will be found that the crossed fibres occupy the dorso-medial part of the periphery of the section, and the uncrossed fibres are situated in the ventro-medial portion of the periphery of the section. The bundles then become divided into a number which are flattened horizontally, and these intermix with one another. The crossed fibre-bundles come together again at the ventro-lateral margin of the chiasm, forming the tract. Then there is a displacement. The crossing does not take place all at one point, but the dorsal nerve-fibre bundles first cross, followed by the more centrally situated ones. (Fig. 59.) At the posterior angle of the chiasm the commissural nerve-fibres, described by von Gudden, Meynert, and Forel, which have no influence on vision, are found.

The disturbance of vision which is pathognomonic of disturbances that interfere with conduction at the chiasm is temporal hemianopsia in its various modifications.

Temporal hemianopsia is observed only in organic lesions or in transient disturbances of vision which result from organic changes, never occurring in disease-conditions of a purely functional character.

Let the chiasm be divided by a frontal incision passing in the direction  $a_1eb$  (Fig. 60) into an anterior and a posterior section. The conducting path is destroyed (the fasciculi laterales plus the fasciculus cruciatus of each hemisphere), causing amaurosis with loss of pupil reflex in both eyes. In the course of some weeks the descending atrophy that follows the division of the

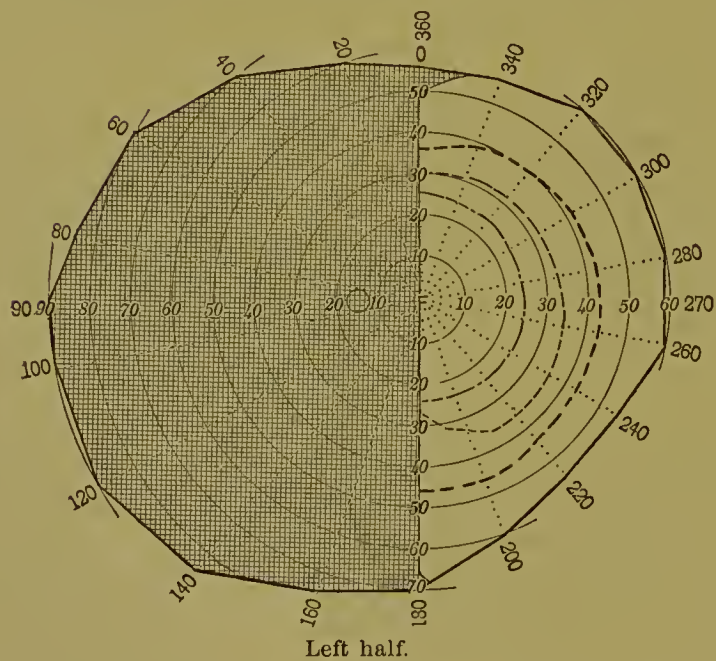
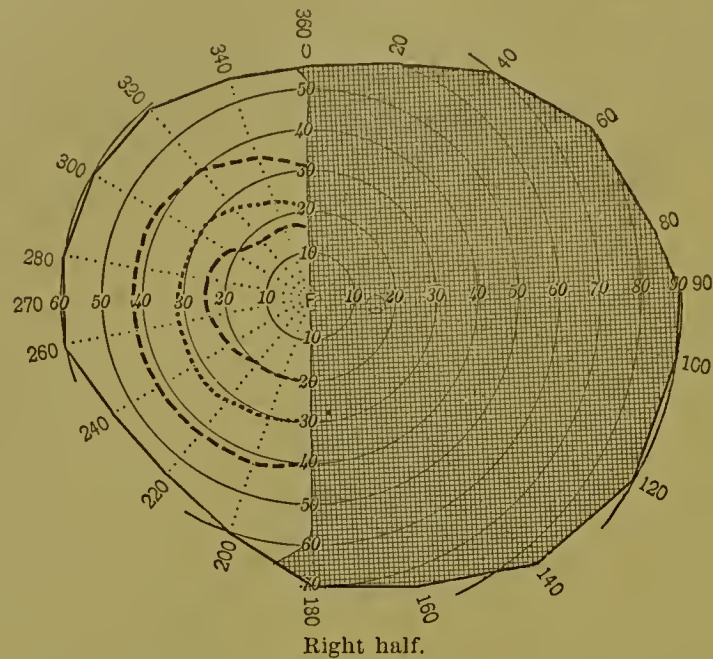
FIG. 60.



axis-cylinders of the whole nerve-trunk (the centrifugal and centripetal) from their primary centre (the anterior corpora quadrigemina and the corpus geniculatum externum) on the one hand, and the ganglion cells which lie in the ganglion-cell layer of the retina on the other hand, causes the fundus, which was at first quite normal, to present gradually the picture of optic atrophy. In contrast to this, let the chiasm be supposed to be divided by a line in the plane of the sagittal suture,  $ced$ , into a left and a right half. (Fig. 60.) The conduction path from the inner halves of the retinae of both eyes ( $mp$  and  $m'p^2$ , Fig. 60) is completely destroyed. This causes the temporal halves of both fields of vision to be blind, and, in consequence of the interruption in the conductivity of both crossed fasciculi, permanent temporal hemianopsia results. After a few weeks the inner halves of the papillae (Fig. 38,  $kr.d.$ ,  $kr.v.$ ) and the temporal halves, which are formed of the crossed bundles of nerve-fibres ( $m'd.$  and  $m'v.$ , Fig. 38), as well as the papillo-macular system, become whitened in consequence of descending atrophy, leaving the fasciculi non-cruciati intact. The nasal half of the field of vision of each eye remains normal, and the normal color-limits of these halves coincide accurately with the vertical line of separation between the two halves of the field of vision. In such a case of typical hemianopsia (see Fig. 61) caused by a division of the chiasm at its centre by a cut in

the plane of the sagittal suture, the blindness of the halves of the field of vision remains stationary, and the nasal halves of the field permanently retain their normal action, partly because the nerve-fibres which are included

FIG. 61.



in the fasciculus non-cruciatus are not separated from their ganglion-cells, and partly because the supply of their nourishment is in no way disturbed.

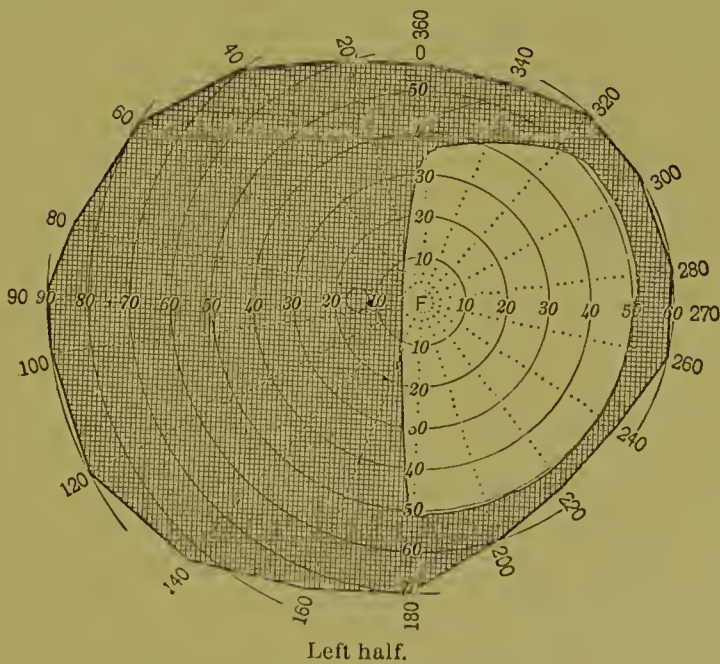
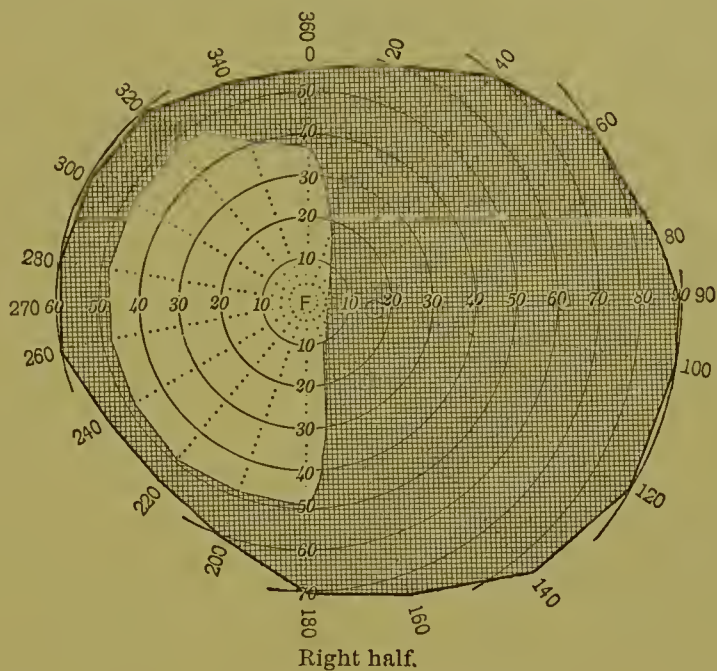
Heubner<sup>1</sup> and Duret<sup>2</sup> assert that each half of the chiasm, exactly to the middle line, is supplied from the basal artery of the brain of the corresponding side, and especially from the two anterior cerebral arteries. The

<sup>1</sup> Die luetischen Erkrankungen der Gehirnarterien, Leipsic, 1874.

<sup>2</sup> Archives de physiologie normale et pathologique, iii. tom. i., January, 1871.

internal carotids on both sides send several twigs to the sides of the chiasm, and the posterior communicating arteries also, in less degree, contribute to the blood-vessels of the posterior portion of the chiasm. The line of separation between the halves of the field of vision in typical temporal hemianopsia does not always necessarily lie in the vertical meridian. It

FIG. 62.



may, in consequence of differences in anatomical conditions, be situated more or less beyond the point of fixation (see Fig. 62), a condition which is termed *overshot field of vision*, and which must give rise to the supposition that the macula lutea is provided with a double set of nerves, one from each hemisphere.

Förster<sup>1</sup> had a case under observation for ten years in which the typical temporal hemianopsia was accompanied by unaltered medial halves of the fields of vision. Weir Mitchell<sup>2</sup> has recorded a case of temporal hemianopsia in which an aneurism had separated the chiasm at its centre, so that the nerve-fibres of each fasciculus cruciatus were entirely destroyed. Siemerling<sup>3</sup> has examined the specimens from a case of temporal hemianopsia microscopically. He found the chiasm so thinned that it was almost divided into two halves in consequence of the pressure of the floor of the third ventricle upon it at its centre.

If a limited portion of the centre of the dorsal surface of the chiasm is altered by a disease-process at the point where the papillo-macular fibres from the fasciculus cruciatus lie at the surface and interlace, then such lesion is followed by paracentral scotomata in the temporal halves of the visual fields to the outer side of the fixation-point in each eye. Here the disease-process, and with it the temporal hemianopic scotoma in each eye, may remain in the same condition, according to the original cause of the disease. Such a condition is illustrated by a case of Beer's.<sup>4</sup> In a boy who died insane a long narrow exostosis was found at the sella turcica which penetrated through the chiasm. Such temporal hemianopic scotomata are described by Vossius<sup>5</sup> and Förster.<sup>6</sup> Such scotomata gradually increase, and include finally the entire temporal halves of the fields of vision. In opposition to this course, a typical temporal hemianopsia may gradually recover until it is merely a temporal hemianoptic scotoma. In such a case possibly a basilar gummatous meningitis, during a certain stage of development of the disease, may have injured the function of the fasciculus cruciatus by pressure (see Fig. 60), whilst at the point of intersection of the papillo-macular fibres interstitial neuritis has produced atrophy of the fibres. Such a case is described by Treitel.<sup>7</sup> (See Fig. 63.) A female, twenty-seven years of age, married to a syphilitic husband, exhibited bilateral temporal hemianopsia, which after fourteen days spontaneously shrank to symmetrical paracentric temporal hemianoptic scotomata.

In contrast to this, if a disease-process acting upon the centre of the chiasm, such as, for example, a tumor of the hypophysis, increases in size evenly, after it has caused a temporal hemianopsia, by the destruction of the fasciculus cruciatus, it may finally interfere with the function of the fasciculus non-cruciatus. Such a process shows itself in the field of vision by a more or less irregular overstepping of the vertical line of division of

<sup>1</sup> Graefe und Saemisch, Handbuch der gesammten Augenheilkunde, vii. 116.

<sup>2</sup> Journal of Nervous and Mental Disease, 1889, xiv. 44.

<sup>3</sup> Archiv für Psychiatrie und Nervenkrankheiten, Bd. xx. Heft 1.

<sup>4</sup> Lehre von den Augenheilkunde, ii. 582.

<sup>5</sup> Von Graefe's Archiv für Ophthalmologie, xxx. 3, 172.

<sup>6</sup> Graefe und Saemisch, Handbuch der gesammten Augenheilkunde, vii. 116.

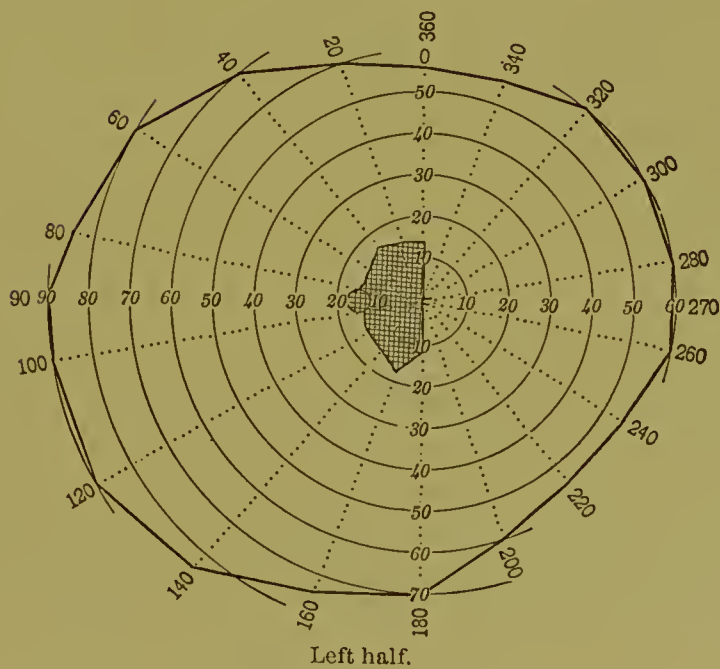
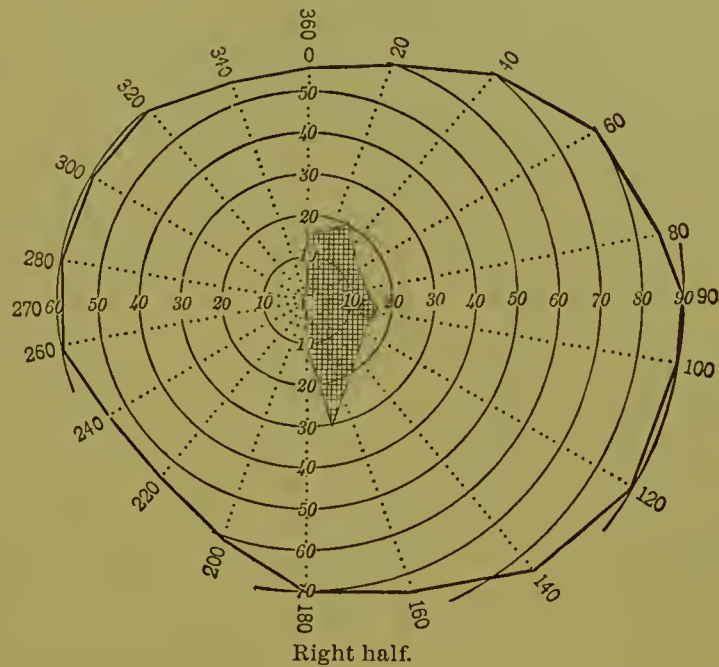
<sup>7</sup> Centralblatt für Augenheilkunde, 1881, 320.



the field, and a blindness of the nasal half of the field. If a patient suffering in this manner is seen only in this stage, the diagnosis of chiasm disease is difficult, because such defects of the visual fields can be caused by disease of both optic nerves at symmetrical points.

If the disease-process has a tendency to spread from the centre of the

FIG. 63.



chiasm farther over one half whilst the other half remains unaffected, blindness occurs in that eye which corresponds with the diseased half, while temporal hemianopsia remains in the other eye. Such a case Hirschberg describes.<sup>1</sup> The increase of the disease-process in one half of the chiasm may also be manifested by the neighboring lower or upper quadrant of

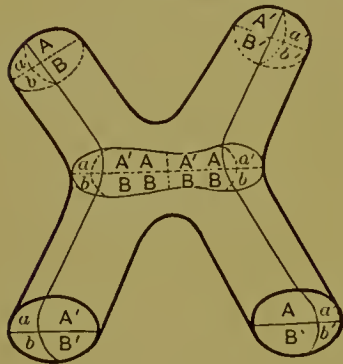
<sup>1</sup> Deutsche Zeitschrift für praktische Medizin, 1878.

the nasal half of the field of vision of the eye corresponding to the diseased portion of the chiasm failing in function, as in the case described by Lang.<sup>1</sup> The temporal half of the field of vision of the right eye in this case was wanting, and in the left eye not only this portion but also almost the whole lower quadrant of the nasal half of the field.

In contrast to this, one fasciculus cruciatus may be quite destroyed, the mischief in the other gradually abating, as in a case observed by Schoen.<sup>2</sup> In this case there was bilateral loss of the outer halves of the visual fields, that of the left eye being complete, whilst only the upper and the outer quadrant of the right had disappeared.

If this process which destroys the function spreads from the anterior or posterior fork of the chiasm towards the fibres of the fasciculus cruciatus, then, should the focus of disease destroy the nerve-fibre bundles supplying both the upper and the inner quadrant of the retina ( $AA'$ , Fig. 64),

FIG. 64.



only both the lower and outer quadrant of the retina will be wanting; or should the nerve-fibre bundles  $BB'$  be altered, only both upper retinal quadrants will be gone. If only  $A$  on the one side and  $B$  on the other (Fig. 64) suffer a diminution of function, defects will be found in the fields of vision corresponding to the lower temporal quadrant of the retina in the one eye and to the upper temporal quadrant of the retina in the other. According to the attack of the disease-focus, sector-shaped or zonular defects in the temporal halves

of the visual fields will be found; and according to the outward pressure and the interstitial neuritic processes, those portions of the nerve-fibre bundles which are nearest to them will lose their conductivity. Treitel<sup>3</sup> has described a case in which the half of the lower and the whole of the upper quadrant of the temporal half of the visual field of the right eye were deficient. In the left eye there was a large wedge-shaped scotoma situated mostly in the upper quadrant of the temporal half of the visual field. This began at the fixation-point, but did not quite reach to the periphery.

The following table shows the forms of defects that are present or develop in the course of typical temporal hemianopsia, or which, commencing as typical temporal hemianopsia, gradually partially recover.

TABLE III.

1. Typical temporal hemianopsia in one eye; in the other the upper outer quadrant was lost. (Schoen, *Die Lehre vom Gesichtsfeld*, S. 71.) According to Fig. 64, a single disease-focus has destroyed  $A'A B'B B'B$ , by which  $A'B'$  the fibres in the right opticus and the conducting path  $B$  in the left opticus failed to act.

<sup>1</sup> *Centralblatt für Augenheilkunde*, 1880, S. 217.

<sup>2</sup> *Die Lehre vom Gesichtsfeld*, S. 71.

<sup>3</sup> *Archiv für Ophthalmologie*, xxv. 3, S. 67.

2. Typical temporal hemianopsia in one eye; in the other the lower outer quadrant was lost. (*A'A B'B A'A.*) (Lang, *Centralblatt für Augenheilkunde*, 1880, S. 217.)
3. In both eyes only the upper and outer quadrants were lost. (*B'B B'B.*) (Schoen, loco citato, S. 71.)
4. In both eyes only the lower and outer quadrants were lost. (*A'A A'A.*) (Dimitrowski, *Centralblatt für Augenheilkunde*, 1880, S. 539.)
5. One eye was blind; the temporal half of the field of vision in the other was also blind. (*A'A B'B ab.*) (Siemerling, *Archiv für Psychologie und Nervenheilkunde*, Bd. xix. Heft 2.)
6. One eye was blind; in the other only the upper nasal quadrant remained active. (*ab A'A B'B A'A B'B a'.*) (The author's case of aeromegaly.)
7. One eye was blind; in the other the lower nasal quadrant remained. (*ab A'A B'B A'A B'B b'.*) (Seguin, *Journal of Nervous and Mental Disease*, 1887, xiv. 721.)
8. In both eyes only the upper nasal quadrants remained active. (*a A'A B'B A'A B'B a'.*) (Schoen, loco citato, S. 71.)
9. In both eyes only the lower nasal quadrants remained active. (No case has been reported.)

As the chiasm with both tracts and the other intracranial portion of both optic nerves may be surrounded by gummatous masses and meningitic thickenings, so may any disease-process spread deeper into the chiasm or separate portions of the tracts or optic nerves, causing irregular defects in the field of vision, from which complicated disease of the chiasm may be assumed.

For inexperienced observers it may be difficult in such cases to make a correct diagnosis from the appearance of the defects of the field of vision. As in such irregular-shaped defects the function is often merely disturbed, it is wise, in order to make more certain of the diagnosis of disease of the chiasm, to test the field of vision for white. To do this, the patient should be placed with his back to the light and made to fix his eye on the examiner's corresponding eye and cover the other. The patient is to be examined with large white surfaces of paper. In this way the form of typical temporal hemianopsia may be obtained.

In considering these irregular defects of the field of vision, the influence of disease-processes in the optic tract and the optic papilla should be taken into account. Basal gummatous meningitis, which often causes disease of the chiasm, has also a tendency, by a descending neuritis and perineuritis, to cause a more or less deep-spreading disease of both optic tracts, with resultant changes in the fields of vision. In this manner, or by means of direct pressure of a tumor, for example, against the chiasm, choked disk may be caused. This occurrence would influence the field of vision in such a manner that the periphery of the nasal halves would be concentrically diminished or would exhibit sector-shaped defects. Further, it should be borne in mind that with a typical temporal hemianopsia there may be a peripheral concentric diminution of the remaining nasal halves of the visual fields through a complication of this trouble with diseases of the papilla and the retina, such as glaucoma simplex, retinitis albuminurica, or functional nervous disorders.

If one half of the chiasm is destroyed by pathological process, as in divisions 5, 6, and 7 of the preceding table, complete blindness of the eye corresponding to the diseased half of the chiasm and temporal hemianopsia of the other will be found. This unilateral blindness, with temporal hemianopsia in the other eye, may be developed in three ways, as follows:

(a) From a case commencing as typical temporal hemianopsia, in which, for instance, a tumor presses on the centre of the chiasm and destroys the function of both fasciculi cruciati ( $AB$  and  $A'B'$ , Fig. 64), but in its farther growth spreads towards one side of the chiasm, and at last also destroys the fasciculus non-cruciatus of this side (about  $ab$ , Fig. 64). Such cases, with section diagnosis, have been described by Uhthoff<sup>1</sup> and Ross.<sup>2</sup>

(b) From a case beginning as a persistent homonymous hemianopsia. The affection of the optic tract (for example,  $ab$ ,  $AB$ ) is followed by a disturbance of the fasciculus non-cruciatus dexter ( $ab$ ) and the fasciculus cruciatus dexter ( $AB$ ) through a failure of function thus caused in the temporal half of the retina of the right eye and the nasal half of the retina of the left eye, producing homonymous left-sided hemianopsia. The disease-process spreads over the corresponding halves of the chiasm, and in that way diminishes the function of the fasciculus cruciatus  $A'B'$  of the left optic tract in  $A'A B'B$ . Thus the conductive powers of the whole right optic tract, and of the nasal half of the retina of the left eye, are interrupted. Here, on account of the homonymous hemianopsia which is present at the commencement, the line of division between the halves of the visual fields is marked. In such cases, even before blindness occurs in one eye, the temporal half of the fields of vision of the second, as well as that of the same side as the diseased tract, gradually weakens until one-sided blindness ensues. If the disease-focus still grows towards the other half of the chiasm, the sharply defined vertical line of separation of the field of vision becomes irregular, and this, coupled with the lessening of the nasal half of the field of vision of the other eye (and diminution of function of  $a'b'$ ), causes blindness gradually to ensue. Such cases, with microscopic examination, are described by Uhthoff,<sup>3</sup> Siemerling,<sup>4</sup> Nettleship,<sup>5</sup> and Hjort.<sup>6</sup>

(c) From the beginning of a unilateral blindness, because in this type of defect the disease-focus has destroyed the right optic nerve just before reaching the chiasm ( $ab A'B'$ ). Later the whole right half of the chiasm becomes involved in the process, so that the conducting path ( $AB$ ) from the left eye is broken. Such cases, with sectional descriptions, are cited by Leudet<sup>7</sup> and Rossander.<sup>8</sup>

<sup>1</sup> Archiv für Ophthalmologie, xxvi. 1, 264.

<sup>2</sup> British Medical Journal, 1881, i. 852.

<sup>3</sup> Loco citato, p. 226.

<sup>4</sup> Archiv für Psychiatrie, Bd. xix. Heft 8.

<sup>5</sup> The Lancet, 1883, ii. 688.

<sup>6</sup> Klinische Monatsblätter für Augenheilkunde, 1867, 166.

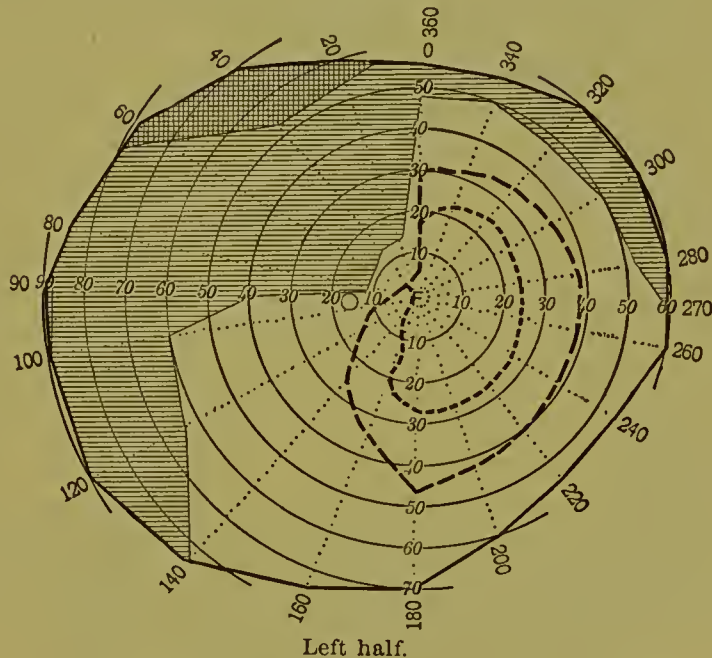
<sup>7</sup> Nothnagel, Topische Diagnostik der Gehirnkrankheiten, S. 519.

<sup>8</sup> Jahresbericht ueber die Leistungen und Fortschritte der gesamten Medicin von Virchow und Hirsch, 1868, ii. 499.

Unilateral hemianopsias are also observed. These cases generally later develop typical hemianopsia in both eyes. A homonymous hemianopsia, however, may also result. The fibres of the optic tract shortly before they enter the chiasm lie in separate strands, so that in this manner any cause of pressure circumscribed to the fibres of the fasciculus cruciatus or at the central surface of the optic tract may attack this or the optic nerve itself only, and thus produce a unilateral temporal hemianopsia. If such a disease-focus gradually spreads, and involves the whole posterior or anterior fork of the chiasm, in the course of time the fasciculus cruciatus of the other eye becomes involved, and thus defects appear in the temporal half of the corresponding field of vision.

The author has described and pictured the fields of vision of such a case.<sup>1</sup> Schoen has also described one.<sup>2</sup> The case whose field of vision is depicted in Fig. 65 is at the present time still under observation. It is

FIG. 65.



that of a man sixty years of age, with gummatous affection of the bones, gummatous inflammation of the testicles, and basilar gummatous meningitis. To a condition of paralysis of the left side with anæsthesia was added a marked defect of the temporal half of the field of vision of the left eye. The field of vision of the right eye was normal. Right vision equalled  $\frac{1}{1}$ ; left vision was  $\frac{6}{18}$ . In the left eye the papilla was slightly redder than in the right. In this case there were undoubtedly gummatous tumors which pressed upon the right pedunculus cerebri, the posterior angle of the chiasm, and the median portion of the right optic tract. After the

<sup>1</sup> Ueber Hemianopsie und ihr Verhältniss zur topischen Diagnose der Gehirnkrankheiten, 1881, S. 50.

<sup>2</sup> Loco citato, S. 70.

use of inunctions of mercury almost complete recovery occurred. Schultz<sup>1</sup> has described such a case in which homonymous hemianopsia developed.

Sometimes a typical temporal hemianopsia recovers, leaving a monocular hemianopsia, as in a case of Schweigger's.<sup>2</sup>

Von Baumgarten and Treitel<sup>3</sup> have described a case, with section descriptions, of unilateral temporal hemianopsia which was due to gummatous inflammation of the cerebral arteries. The disturbance of function in this case was caused, according to Treitel, by an obliteration of the vessels to the nerve-fibres of the fasciculus cruciatus of one optic tract at its point of departure from the chiasm.

A one-sided monocular hemianopsia may be caused by pressure in the angle of the chiasm acting on the fibres of the fasciculus non-cruciatus which pass along in this position (Fig. 64, *ab* or *a'b'*). A glance at Fig. 64 shows that only such a monocular nasal hemianopsia could be caused by such single-sided disease-focus. A case of nasal monocular hemianopsia in which the line of separation between the two halves of the field of vision is sharply defined in the vertical meridian has been observed by Uhthoff and described and pictured by Jevers.<sup>4</sup>

Henschen<sup>5</sup> cites a case of blindness of the left eye with nasal hemianopsia in the other. Such a form of hemianopsia cannot be due to a single focus of disease. In his case the microscopic section showed in conformity to this not only that the whole chiasm was situated in a gummatous inflammation, but that the actual mass of the tumor which caused the hemianopsia of the right eye was pushed farther back and had destroyed the right tract, whilst in the same way the uncrossed left bundle in the outer angle of the chiasm was involved, so that only the left fasciculus cruciatus appeared relatively intact.

Knapp<sup>6</sup> has described a case of bilateral nasal hemianopsia with a study of the microscopic sections. In this case disease of both the lateral angles of the chiasm was caused by degeneration of the arteries of the corpus callosum. These vessels were found to be converted into two very inelastic cords placed in contact with the outer sides of the chiasm.

The cases of nasal hemianopsia described by other authors seem to belong to symmetrical disease of both optic nerves, because in none were found distinct lines of separation of the two halves of the fields. Thus, Strümpell<sup>7</sup> records an instance following a multiple degenerating neuritis. In this case a commencing atrophy was found in the outer sections of both optic nerves.

<sup>1</sup> Deutsches Archiv für Klinische Medizin, xxxv. 468.

<sup>2</sup> Archiv für Ophthalmologie, xxii. 3, 319.

<sup>3</sup> Virchow's Archiv, 1888, cxi. 251.

<sup>4</sup> Zur Symptomatologie der retrobulbar Neuritis. Dissertation, Berlin, 1887, S. 12.

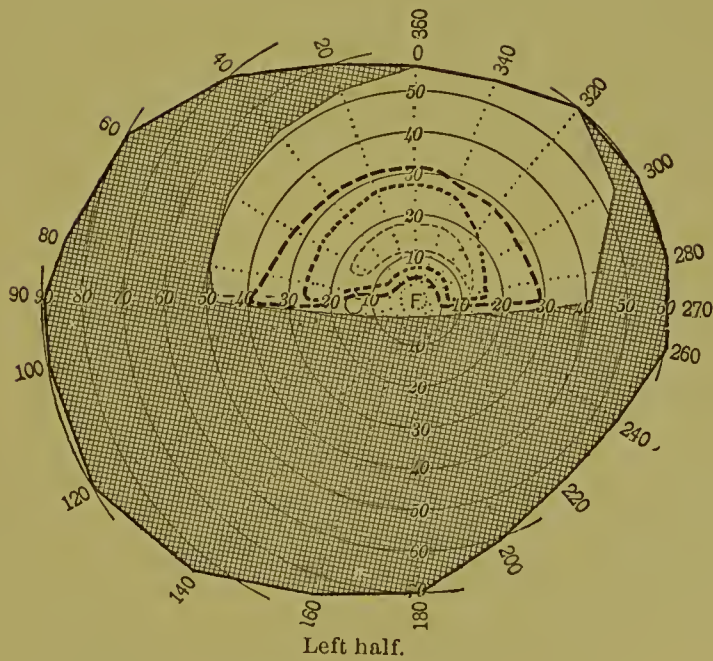
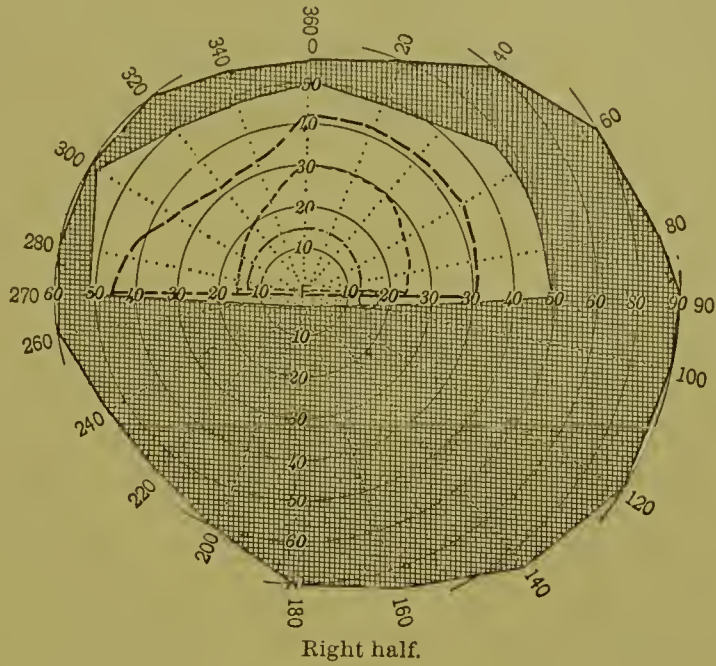
<sup>5</sup> Klinische und anatomische Beiträge zur Pathologie des Gehirns.

<sup>6</sup> Jahresbericht für Ophthalmologie, 1875, 372.

<sup>7</sup> Archiv für Psychiatrie und Nervenkrankheiten, xiv. 339.

Theoretically, it is conceivable that cases of binocular superior or inferior hemianopsia can occur. For example, a gummatous infiltration might involve only the upper half of the chiasm (*a A' A' A' a'*, Fig. 64), thus

FIG. 66.



not permitting the right optic nerve (the bundle *aA'* in the left *Aa'*) to conduct any impressions of light from the upper retinal halves of the two eyes.

The only case the author is acquainted with, in which microscopic sections have been studied, is one described by Russell.<sup>1</sup> The case was one of basilar bone tumor with paralysis of the eye-muscles, producing

<sup>1</sup> The Medical Times and Gazette, 1873, ii. 91.

a hemianopsia which cut out the upper part of the right field. Complete blindness, commencing in the right eye, followed. Unfortunately, there was no study of the microscopic conditions.

Uhthoff<sup>1</sup> pictures an interesting case of inferior hemianopsia (Fig. 66). It was suspected that this field-defect was caused by symmetrical disease of the optic nerves. The patient was suffering from tabes dorsalis.

During the periods of development and recovery from temporal hemianopsia, large zones of so-called deadened perception (Fig. 65), in which a white examining object is perceived as more or less gray and colors cannot be distinguished, are often found in the temporal halves of the fields. The same relation between the color-limits and the limits for white as exists in diseases of the optic tract is met with in temporal hemianopsia, except that, owing to the peculiar course of the nerve-fibres, it remains limited, at least in typical temporal hemianopsia, to the temporal half of the visual field. If a disease-focus interferes merely with the fibres of the crossing bundle, there is no reason why color-perception through the fasciculus non-cruciatus should be disturbed. The color-fields, therefore, coincide sharply with the line of separation of the nasal fields of vision, or they may overlap them, in accordance with the relations of the defect to the temporal halves. Yet if the color-limits retire from the line of separation into the region of the nasal halves of the fields of vision, and if the field for red gradually disappears, these signs show that the disease-process has affected the fasciculus non-cruciatus, even when the outer limits for white in this half of the field of vision remain normal or nearly so. The normal relation of the color-limits to the line of separation of the halves of the field of vision in temporal hemianopsia offers no certainty in regard to prognosis, as it cannot thus be determined whether the disease will cease with the destruction of the crossed bundles or will pass beyond these to the other fibres. The fields of vision found in diseases of the chiasm thus afford only a glance, as it were, into the momentary condition of the optic path. Even after blindness due to disease of the chiasm has appeared, intact or nearly normal power of vision may return. If the color-limits in the temporal halves retire from the limits for white, and the defect for white increases in size, the process in the territory of the crossed-fibre bundle should be regarded as progressive. If the process, by slow but steady growth, has overstepped the limits of the nasal halves of the fields, this should be considered a serious sign. The disease may even then come to a halt, although there may be but a small quadrant of the nasal half of the field of vision remaining, as occurred in a case under the author's observation. From this it may be concluded that caution should be exercised in making a prognosis in disease of the chiasm.

It is well to direct attention to the fact that no case has ever been

---

<sup>1</sup> Beiträge zur Pathologie der Sehnerven und der Netzhaut, 1884, S. 16.



found in which there was an absolute loss of every trace of color-sensation from the temporal halves of both fields of vision, in which the limits for white were completely intact, as demonstrated by an examining object five millimetres square, and in which there were perfect isopters in the color-blind halves. This point is important because in homonymous hemianopsia occasionally a so-called manifestation of color-hemianopsia is asserted.

In typical cases of temporal hemianopsia the binocular field of vision is diminished towards each outer side. If the disease-process has produced atrophy of the fasciculi cruciati, while the fasciculi non-cruciati remain intact, orientation with binocular vision will still be good. If in both nasal halves of the fields a so-called "overshot" field, in which the fixation-point of the two nasal halves of the fields of vision is overreached, is present, and there is a double innervation of the macula lutea, central acuteness of vision suffers little or not at all. Central vision can also be quite good when in the one eye the disease-process has overstepped the line of separation towards the nasal half of the field, while in the other eye there is present an intact field which reaches over the fault in the first field and completely covers the deficient macular region of the first. If the disease-process, however, has passed into the nasal halves of the fields of both eyes in the region of the fixation-points, then a central scotoma in the binocular field of vision, with all the conditions impairing direct vision which follow it, will appear.

As regards the relation of central visual acuteness in temporal hemianopsia, the following may be asserted :<sup>1</sup>

TABLE IV.

In a large number of cases of disease of the chiasm with described sections the condition of visual acuteness was found as follows :

Seventeen at latest condition, complete bilateral amaurosis.

Two hundred and forty-two, amaurosis in one eye, amblyopia in the other.

One, amaurosis in one eye, normal acuteness in the other.

Fifteen, bilateral amblyopia.

Five, amblyopia in one eye, normal acuteness in the other.

Four, normal acuteness in both eyes.

Six, normal acuteness in one eye.

In twenty cases of temporal hemianopsia without description, sections showed as follows :

Two, amaurosis in one eye, amblyopia in the other.

Sixteen, amblyopia in both eyes.

One, normal visual power in both eyes.

One, amblyopia in one eye, normal acuteness in the other.

The condition of the central acuteness of vision in temporal hemianopsia is dependent on whether the crossed and uncrossed fibres of the papillo-macular nerve-fibre bundles in their course through the chiasm have

<sup>1</sup> Wilbrand, Ueber Hemianopsie und ihr Verhältniss zur topischen Diagnose der Gehirn-Krankheiten, 1881, S. 85.

suffered a direct lesion or whether they are indirectly disturbed by pressure. As these bundles lie close to one another (see Fig. 59,  $m'$ ,  $m$ ,  $m'$ ), in the destruction of the crossed bundle the uncrossed portion whose fibres lie close to it in the papillo-macular bundle is easily injured by pressure, and may in that way give cause for a lessening of central acuteness of vision, even in the remaining active nasal half. Still more normal acuteness of vision in one eye may be expected when the disease-focus has involved only one half of the chiasm and accordingly the fasciculus non-cruciatu of the other remains at a relatively great distance from the focus. It is well to remember that there is always more or less intense action at a distance from the actual focus of disease, at least in acute disease. Uthoff<sup>1</sup> believes that twenty per cent. of the cases of temporal hemianopsia are caused by syphilis.

Among the characteristic symptoms of basilar cerebral syphilis is a remarkable fluctuation in the manifestation of the disease. Sudden blindness, rapid resolution into temporal hemianopsia, limitation of the nasal half of the field of vision, irregular defects in the field, blindness of one eye, and resolution and complete recovery, in disease of the intracranial optic tract, as well as in disease of the chiasm, are not unusual symptoms.

Insight into this remarkable fluctuation of the visual disturbance may be gained if Oppenheim's finding<sup>2</sup> that syphilitic tumors are rich in vessels whose walls are markedly changed, and the degree to which the structures are disturbed through destruction of the intima or diminution of the lumen or actual closure by the process of thrombosis, are considered. Further, it must be remembered that the tissue which has thrust itself between the chiasm and the base of the brain and which shows processes between the fibres of the visual nerve is extremely capable of distention.

As complete recovery is often observed after the use of antisyphilitics, the prognosis of temporal hemianopsia may be considered to be good. Sell<sup>3</sup> has recorded a series of such cases. For the same reason there can be no doubt that in blindness due to basilar meningitis of gummatous type the visual power may be almost completely regained after energetic treatment.

Often temporal hemianopsia is caused by a tumor which has its seat in the region of the chiasm. In a collection of the literature on the subject up to the year 1880<sup>4</sup> the writer has found tumors of the sella turcica fifteen times, of the hypophysis cerebri eleven times, of the chiasm five times, growing in the floor of the third ventricle five times, at the side and the base of the skull three times, and at the crista galli four times. Tubercles were demonstrated in the chiasm three times.

<sup>1</sup> Loco citato.

<sup>2</sup> Virchow's Archiv, civ. 315.

<sup>3</sup> Chiasmaerkrankungen. Inaugural Dissertation, Leipzig, 1894, S. ii.

<sup>4</sup> Wilbrand, loco citato, S. 87.

Tumors may also press upon the chiasm without producing actual disturbance of vision, as in a case of A. Levii.<sup>1</sup> Sell, in the dissertation mentioned above, has collected the cases from the year 1880 to the present date. The etiology of these appears to have been as follows: seven cases by trauma, twenty-five by tumors, six by tuberculous exudations or granulations, four by aneurisms, two by pressure from the third ventricle, two by periostitis, four by partial meningitis, sixteen by basilar gummatous meningitis and syphilitic disease of the chiasm, one by gummatous arteritis, one by hemorrhages into the chiasm, one by multiple sclerosis, and one by hyperplasia in elephantiasis.

A change in the relation of the defects of the field of vision always indicates activity in the process, and therefore must be considered in the prognosis. Passing weakness of vision and blindness may occur in cases of tumors of the base, and are due to pressure of the floor of the third ventricle caused by intercurrent or consequent hydrocephalus. Tumors that are capable of swelling may cause this. Sometimes when patients bend forward blood-circulation is stopped, occasioning increased blood-pressure.

The chiasm is covered on its upper surface by the recesses of the third ventricle. Such a condition is carefully described by Michel.<sup>2</sup> In normal conditions it reaches to the anterior angle of the chiasm in the mesial line, and in internal hydrocephalus it may readily influence the central portion of the chiasm. Siemerling<sup>3</sup> describes a case in which the chiasm was thinned and almost divided into two halves by the pressure of the floor of a greatly distended third ventricle.

Temporal hemianopsia may occur as a single focal symptom. This is sometimes the case when the defect is caused by exostosis of the base of the skull or in a partial meningitis. In these cases, when no form of therapeutics has effect, the field-defects stop at a certain stage of development. Even after secondary blindness the cerebral symptoms may cease, and the patient live for a long time, as in the cases described by Osler.<sup>4</sup> It is doubtful whether hemianopic disturbances occur in simple progressive atrophy of the visual nerves, although theoretically their appearance may be accepted. In any case, a temporal hemianopsia due to gummatous meningitis may appear concurrently with tabes dorsalis, as in an instance cited by Uhthoff.<sup>5</sup>

In a case described by Gowers<sup>6</sup> there were similar accidental complications, probably symmetrical disease of the visual nerves, in which the disturbance of vision appeared quite suddenly as a nasal hemianopsia in a case of tabes dorsalis. The author has seen such a case in a patient suffer-

<sup>1</sup> Jahrbuch für Ophthalmologie, 1890, S. 479.

<sup>2</sup> Archiv für Ophthalmologie, Bd. xix. ii. S. 81.

<sup>3</sup> Archiv für Psychiatrie und Nervenkrankheiten, Bd. xx. Heft 1.

<sup>4</sup> Journal of Nervous and Mental Disease, 1887, xiv. 657.

<sup>5</sup> Loco citato, S. 226.

<sup>6</sup> Manual of Diseases of the Nervous System, vol. ii.

ing from the same disease. (Compare Fig. 50.) The right eye showed a normal field of vision with normal acuteness of vision. Over the surviving temporal half of the field of the left eye only large colored objects could be recognized.

THE FIELD OF VISION IN DISEASES OF THE OPTIC CONDUCTING PATHS FROM THE COMMENCEMENT OF THE TRACTS TO THE CORTICAL CENTRES OF VISION.

Homonymous hemianopsia (also called lateral) is a pathognomonic disturbance of the visual field for all anatomic lesions of the visual apparatus, beginning at the optic tract and extending to and including the centres of vision in the region of the calcarine fissure.

It is never seen in purely functional nervous conditions in the sense of hysteria and neurasthenia, but may be added to a case of hysteria. In such a case the fields of vision will show the hemianopic defects, together with concentric diminution of the remaining portions of the field.

Homonymous hemianopsia is, accordingly, the result of organic disease which either directly or indirectly destroys the conducting nerve-fibres of the optic tract in some point of the portion above described. In the first type the hemianopsia is permanent. In the second it disappears as soon as the pressure decreases sufficiently to permit of proper conduction. Thus a fugitive hemianopsia appearing as an indirect focal symptom is often met with in permanent aphasia and hemiplegia. Frequently the primary loss of the homonymous halves resolves itself in the course of a few weeks into an incomplete homonymous hemianopic defect. Here the actual focus of disease has destroyed only a portion of the optic conducting path, whilst the remaining fibres are rendered temporarily inactive by pressure.

In typical right-sided homonymous hemianopsia total loss of the right halves of the fields of vision is found, the line of separation coinciding with that of the division into the nasal and temporal halves of the fields of vision. An analogous condition of the left halves of the fields of vision of each eye is seen in typical left-sided homonymous hemianopsia.

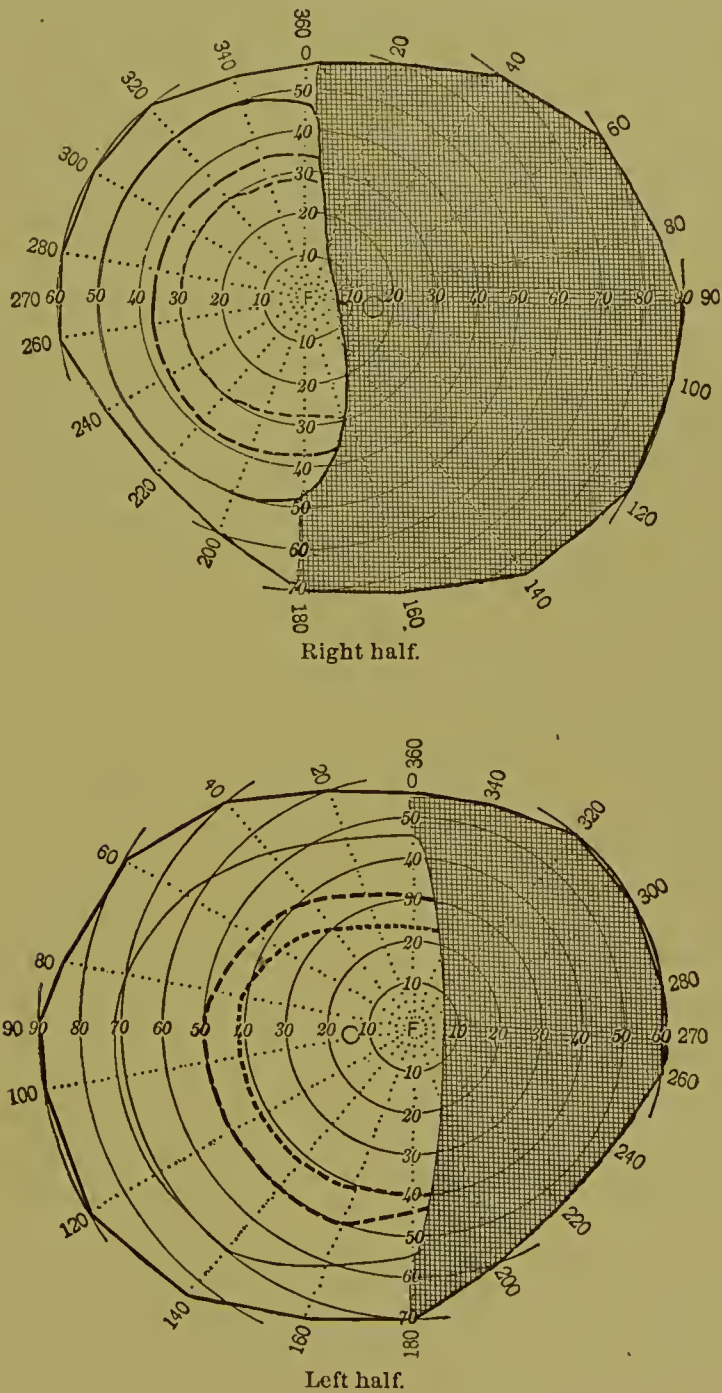
As regards the position of the line of separation in the vertical meridian, a series of individual differences is met with. In one series of cases this vertical line of separation lies mathematically in the vertical meridian of the fields of both eyes and cuts through the fixation, as in the observations on right-sided homonymous hemianopsia by Pooley<sup>1</sup> and on left-sided homonymous hemianopsia by Baumgarten.<sup>2</sup> In another type the line of separation is carried past the fixation-point, to the advantage of the remaining halves of the fields of vision. As those portions of the field which lie beyond the vertical meridian reach into the territory which is covered by

<sup>1</sup> Archiv für Augenheilkunde und Ohrenheilkunde, 1877, ii. 27.

<sup>2</sup> Centralblatt für die Medicinische Wissenschaften, 1878, xxii.

the optic tract of the other hemisphere, and in that way appear superfluous, they are known as "the overshoot portions of the field of vision." The picture of such an overshoot field of vision is shown in Fig. 67. It was taken from a twenty-four-year-old woman who from earliest childhood suffered from complete right-sided homonymous hemianopsia. Three days

FIG. 67.



before her death, during a condition of comparatively good health, the field of vision was examined and recorded. The patient bled to death after an operation for trepanning. The left occipital lobe appeared to be changed into a crumbling mass, and was greatly contracted. There was a descending atrophy of the left optic tract extending deep into the chiasm, proving

that the overshoot portions of the visual field had an organic relation with the organization of the right optic perception centre and its conducting path. Analogous observations confirming this have been made by von Monakow.

Assuming in one of these cases of homonymous hemianopsia that the path of vision leading to the optic centre of the other hemisphere is provided with such areas, they would appear in the following form (Fig. 68) on both sides of the vertical line of separation in the binocular visual field.

FIG. 68.

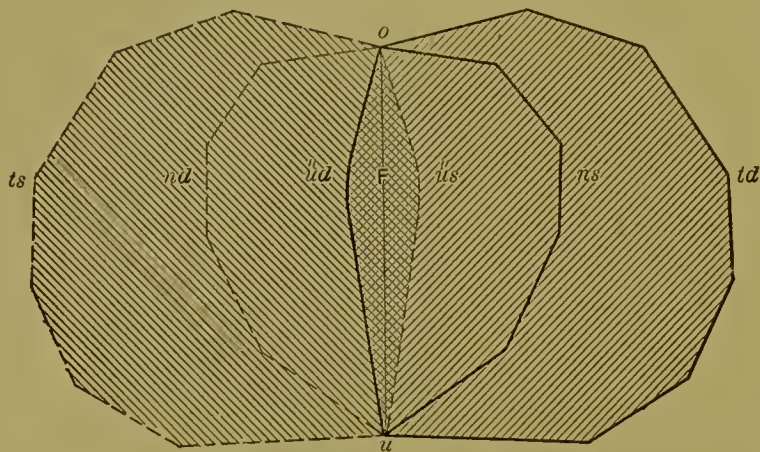


Diagram illustrating the effects of overshoot fields in hemianopsia.

*Otdüido* would be the temporal half of the field of the right eye, and *onsüido* the nasal half of the field of the left eye. In total left-sided homonymous hemianopsia, *otdüido* would represent the bounds of the remaining field of vision in the binocular field of vision. In the monocular field of the right eye *otdüido* would represent the temporal half, and in the left eye *onsüido* the nasal half which remains active, because *otdüido* represents the visual field of the right eye and *otsunso* the visual field of the left eye. *OüduFo* represents the overshoot visual field of the left hemisphere, and *oüsuFo* the overshoot field of the right hemisphere. From this it must be concluded that for each eye the region lying between *oüdüiso* is directly related to the cortical optic centre of both hemispheres. We describe this process as *double provision for the macula lutea*, because usually these overshoot portions of the field of vision are confined to regions of the macula lying around the fixation-point.

In those cases in which the line of separation of the homonymous halves of the visual field lies in the vertical meridian, as in Fig. 69, the former half of the macular portion (chiefly the portion of the field of vision passing along the vertical meridian) comes in relation only with the cortical centre which corresponds to this half.

The overshoot portion of the visual field presents itself in many different ways. Usually the line of separation encloses only the fixation-point, and in some cases it includes only portions of this point. It may be situated to the under half of the line of separation, which is here surrounded by the

overshot field of vision, as is the case with the upper part of the region, or there may be a strip of overshoot field of the same width along the entire vertical meridian.

FIG. 69.

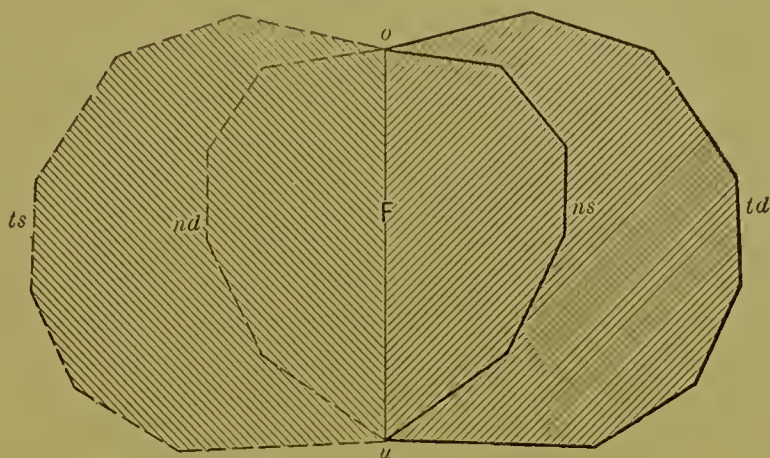


Diagram illustrating overlapping of visual fields.

The overshoot portion is further characterized by the fact that the color-field boundaries coincide accurately with the line of demarcation which it forms. This is of the greatest importance, because otherwise it might be easily and falsely concluded that the portion which extends over the median line was the remnant of an incompletely destroyed conducting tract in a case, for example, of a hemisphere, by which a homonymous hemianopsia is caused. Finally, in these cases there is no color-field reaching to the vertical meridian, or perhaps only the blue field may be found to extend so far in the remnants of the retained portions of the field.

The "overshot" portion of the field is due to differing anatomical conditions of the conduction paths and cortical centres. In consequence of this, the line of separation between the halves of the fields in homonymous hemianopsia usually presents one of the following forms: (1) it passes over the separating line in the vertical meridian; (2) it consists in an overshoot field of vision; and it passes over the separating line in a sloping direction, as, for example, in a case of Siemerling's,<sup>1</sup> in which the absolute defect passed across the median line in a wedge-shaped manner in the upper portion of the field, whilst in the lower portion there was a similarly-shaped portion which did not reach this line.

In order to locate the exact position of the line of separation, and its relation to colors, an examining surface two millimetres square should be used. The patient must maintain accurately the central fixation of sight. For this purpose it is best to have a small black point in the centre of the white surface used for the fixation-object, and to require the patient to fix upon this point. A slight change in the fixation moves the line of separation from the fixation-point and produces apparent irregularities in its course.

<sup>1</sup> Archiv für Psychiatrie und Nervenkrankheiten, Bd. xxi. Heft 1.

Typical homonymous hemianopsia is always absolute; that is, in the defective halves of the field every impression is as completely lost to view as are those falling on the blind spot. If only a portion of the optic tract be rendered inactive, the hemianopic disturbances will appear as partial defects. Incomplete homonymous hemianopsia should be differentiated from the following characteristic forms of defects in the homonymous halves: (a) Quadrant-hemianopsia, in which either the upper or the lower quadrant of the affected homonymous halves is deficient. (b) Retention of an octant in the defective halves of the visual fields. This usually lies upward or downward in the vertical meridian. (c) The loss of corresponding sectors in the homonymous halves. (d) Island-like defects in the corresponding points of the homonymous halves. These island-shaped defects may extend to the fixation-point, or to the intermediate or peripheral zones. They always lie at corresponding points in the homonymous halves of the fields. The island-shaped homonymous hemianopic defects may be easily overlooked, especially if they are small and are situated at some distance from the fixation-point. If such scotomata include the macular portion of the homonymous halves of the fields, they will appear smaller if there is an "overshot" portion in the macular region. This circumstance must be taken into account when the size of the defect in the field is compared with that of the focus in the optic tract. (e) Retention of a peripheral zonal ring in the fields, usually in the lower or the upper quadrant and reaching to the horizontal meridian of the defective halves of the field. If this zone is narrow and extends only beyond the limits of the blue color-field, it can be demonstrated only by white examining objects. (f) The retention of corresponding islands of active perception in the defective homonymous halves of the fields. (g) The loss of a peripheral zone at corresponding points of the homonymous halves of the fields.

The author has given a description of these types of fields in his work entitled "Die hemianopischen Gesichtsfeld-Formen und das optische Wahrnehmungszentrum," published in Wiesbaden in 1890.

If the disease-focus which causes these incomplete homonymous hemianopsias is narrowly circumscribed and causes no direct pressure on the surrounding tissues, the color-limits in the affected regions of the homonymous halves correspond with the defects.

Besides these complete and incomplete hemianopic defects, there is a series of defects which are relative in type. These generally appear in one of the following forms: (a) Either a wide or a narrow zone of diminished perception, in which colors, possibly with the exception of blue, are not perceived. If blue is recognized it is only partially, lying between the absolutely defective portion of the field and that in which there is normal function. (b) The hemianopic defect causes diminution only in power of perception, and consequently there is no absolute defect. (c) There is loss of color-perception only in the homonymous halves of the field.



The central and peripheral visual acuteness and the extent of the field of vision remain normal, or very nearly so, in these cases of so-called "color hemianopsia."

If in the course of a case of incomplete hemianopsia the defect increases, the disease-process in the hemisphere corresponding to the diseased halves of the fields is progressive. If this increase is sudden, the augmentation in the hemianopsia is caused by fresh embolic or apoplectic foci.

If the defect decreases, the disease-process is lessening, because those fibres which were injured in their activity by pressure are regaining their functional power. If the disease-focus is situated in the neighborhood of the optic conducting tract, and causes no anatomical destruction, complete resolution and recovery of the homonymous hemianopsia may occur, even if the physiological disturbances have been absolute. During this process of recovery perception of light, that of dark, and that of color are successively regained.

Many cases of relative hemianopsia perceive waves and bubbles, as if dark gauze shades were shoved one over the other beyond the defective halves. They may see a fog, or a veil.

If in cases of previous homonymous hemianopsia the patient complain of flickering on the affected side, and no defect can be demonstrated with an ordinary examining object, smaller and smaller objects must be used in the perimeter. In this manner Schweigger<sup>1</sup> demonstrated a hemianopsia by examining the area by the aid of the head of a needle.

Some cases of absolute homonymous hemianopsia perceive strong impressions of light in the region of the defective homonymous halves. In such instances, though the path of conduction between the chiasm and the cortex is broken, yet there is a mechanical or inflammatory irritation of the centripetal optic conducting nerve-fibres, which conduct the light-impressions to the cortical centre, where they are recognized as such. These occur mostly a few days after the onset of the defect, and usually disappear. The author has observed this phenomenon in a patient suffering from hemiplegia, hemianæsthesia, and hemianopsia. Westphal<sup>2</sup> has demonstrated the same symptom in a case of hemianopsia after distention of the medullary substance of the occipital lobe with an affection of the same. Gowers<sup>3</sup> has seen such impressions of light in a case of tumor of the membranes of the occipital lobes. Cases are often observed in which visual hallucinations occur in the direction of the defective homonymous halves of the fields. The author has described such a case.<sup>4</sup> Here there was a focus about the size of a bean near the cortex of the occipital lobe, lying to one side of the sagittal medullary fasciculus.

---

<sup>1</sup> Archiv für Ophthalmologie, xxii. 3, 288.

<sup>2</sup> Charité-Annalen, Bd. vi.

<sup>3</sup> The Lancet, 1879.

<sup>4</sup> Die hemianopischen Gesichtsfelds-Formen, Wiesbaden, 1890, S. 58.

Analogous cases are described by Henschen,<sup>1</sup> Putzel,<sup>2</sup> Wollenberg,<sup>3</sup> and Peterson.<sup>4</sup> This last case is remarkable. In a woman with healthy eyes hallucinations of vision appeared in both right halves. These never extended beyond the middle line. If the patient turned towards the right the illusions turned the same way.

The accompanying scheme and chromolithograph show the most important combinations of the visual paths described by Henschen.

FRONTAL DIVISION (from the bulb to the central ganglia).

MIDDLE DIVISION (the central ganglia).

Visual fibres (blue), passing and terminating as centripetal (clear and dark blue), uncrossed, crossed, and macular fibres in the outer corpus geniculatum. Centrifugal fibres (red), passing from the outer corpus geniculatum, and ending in the retina (orange and clear red), crossed, uncrossed, and macular bundles. (?) Reflex fibres passing from the retina (dark and clear violet) and terminating (1) in the pulvinar (superficial deep fibres), (2) in the colliculus anterior, for the pupillary nerves (yellow), for the eye-nerves (yellow), for the other motor nerves of the medulla oblongata and the medulla spinalis (dark violet), by means of the posterior longitudinal bundle.

OCCIPITAL DIVISION (vertical medullo-occipital visual radiation).

Visual (centripetal) fibres (clear blue), passing from the cells of the outer corpus geniculatum and ending in the cortex of the calcarine fissure. The non-visual centripetal fibres (dark blue), passing from the corpus geniculatum and ending in the cortex. Centrifugal fibres (red), passing from the cells of the cortex and ending in the pulvinar (reflex fibres), in the colliculus anterior (reflex fibres). Descending fibres (brown), passing from the cortex through the hindmost division of the internal capsule into the pons. Association fibres (brown), interhemispherical (1) from left hemisphere to right, (2) in the contrary direction, intracortical (green), intergyral (green), between the cuneus and the lingual lobe (green), between the median and the lateral cortex (green), interlobar, between the occipital and the other lobes (gyrus angularis temporalis, etc.),—fasciculus longitudinalis inferior (green).

1 = capsula interna.

2 = corpus lenticulare.

3 = colliculus anterior.

4 = ganglion geniculatum internum.

5 = pulvinar.

6 = ganglion geniculatum externum.

In this scheme the following fibres are not included: Beehterew's fibres from the chiasm to the third ventricle; Bogrow's fibres from the tract to the

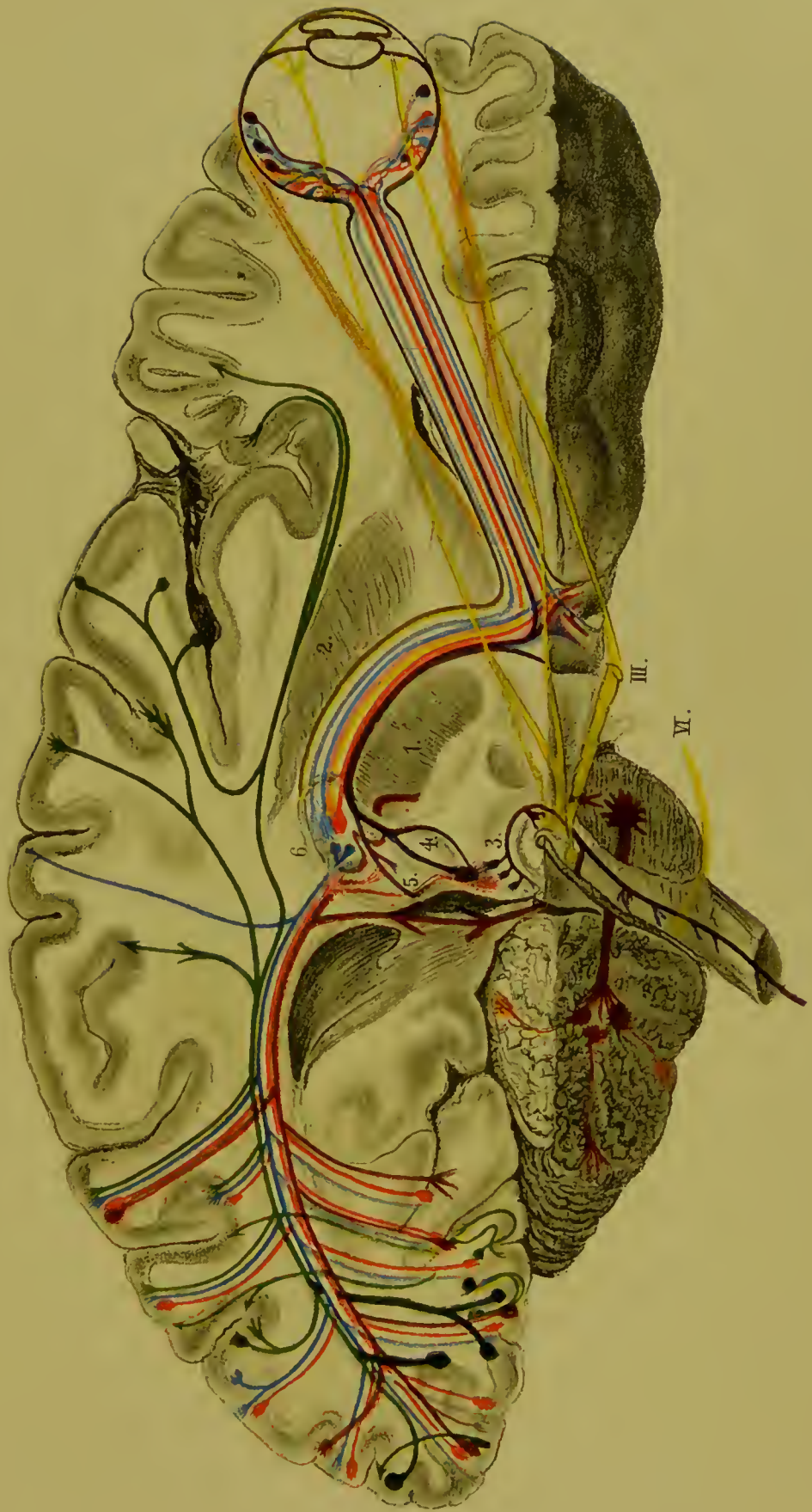
<sup>1</sup> Klinische und anatomische Beiträge zur Pathologie des Gehirns.

<sup>2</sup> Medical Record, 1888, June 2.

<sup>3</sup> Archiv für Psychiatric und Nervenkrankheiten, xxi. 778.

<sup>4</sup> New York Medical Journal, August 30, 1891.

FIG. 70.



Heuschen's scheme of visual paths.



thalamus; v. Monakow's fibres from the tract to the lenticular ganglion; v. Gudden's fibres from the tract direct to the cortex; Edinger's fibres (in amphibia); Perlia's fibres to the medulla oblongata; v. Monakow's fibres from the colliculus anterior to the eyeball; Bernheimer's fibres from the tract to Luys's body; v. Gudden's fibres to the tractus peduncularis transversus; Darkschewitz's fibres from the tract to the ganglion habenulæ.

The bright-blue so-called visual fibres convey the retinal irritation to the optic perceptive centre and represent the fibres used for the special action of sight. By their destruction homonymous hemianopsia is produced. Hallucinations of the destroyed homonymous halves of the visual fields are caused by irritation from a focus of disease which acts on the dark-blue centripetal fibres. They also pass from the corpus geniculatum and intercept the clear-blue visual fibres at some point, possibly near the cortex, the cortex of the occipital lobe, with the exception of the region near the calcarine fissure, being considered answerable for the existence of optic memory-pictures.

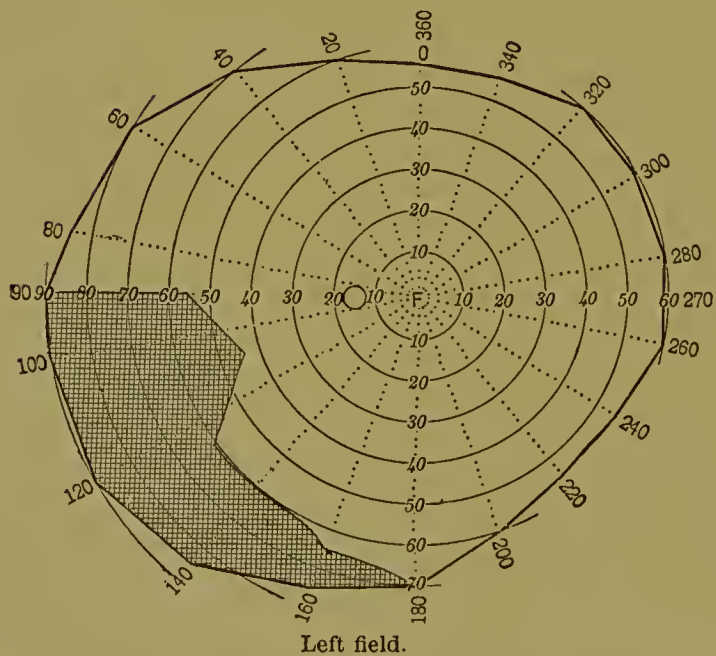
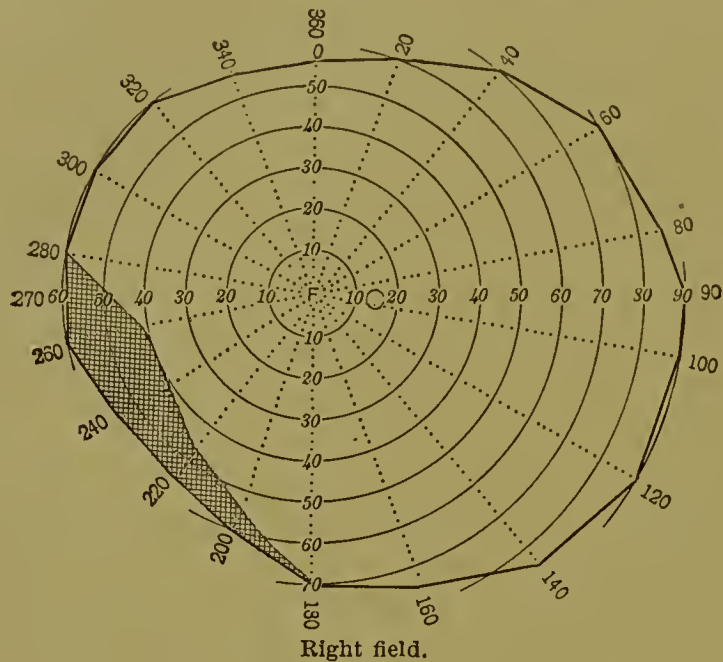
Notwithstanding the facts that the relative areas of the temporal and nasal halves of the field of vision are about in the proportion of two-thirds to one-third, and that hemianopsia is characterized by identical defects, yet defects in the visual field in cases of homonymous hemianopsia which differ between absolute and complete incongruity are continually met with. This is of great importance, particularly in regard to individual irregularity in the optic perceptive centre. As the temporal half of the field of vision in the binocular field of vision is about one-third greater in extent than the nasal half (see Fig. 14), so must the areas of retinal surface in relation to this overreaching temporal field of vision be connected again with their cortical field by a closed conducting bundle. This closed conducting bundle can be formed only of fibres which cross one another, because it belongs only to the temporal side of the field of each eye. If this bundle or the cortical surface of the visual centre which is related to it be alone injured, the loss of function of the field in the eye of the other side of the peripheral third, corresponding to the temporal half, is perceived. Here there would be a case of absolute incongruity of a field of vision belonging to a hemianopic disease-process, which still only through the rarest chance might be found in such purity. If, however, the disease-focus extends beyond this closed bundle of visual spreading fibres or over the cortical area corresponding to it, then there must be elements of function which belong to the fasciculus non-cruciatu of the homonymous retinal half of the eye belonging to the foci of the same side. According to this, the nasal homonymous half of the field of vision of the other eye would show a defect at a corresponding point that would have a smaller extent than the corresponding temporal half of the other eye, as in the case observed by Förster, shown in Fig. 71.<sup>1</sup>

---

<sup>1</sup> Wilbrand, Die hemianopischen Gesichtsfeld-Formen, S. 147.

Incomplete homonymous defects of the field of vision—for instance, island-shaped scotomata lying in the hemianopic region of the binocular field of vision—may be so placed that the nasal and temporal halves are situated towards both sides of the vertical meridian (Fig. 14, *O R D v R' S O*),

FIG. 71.



and may show absolute congruity, as in a case observed by the author.<sup>1</sup> The quadrant hemianopsia may show a relative congruity in the proportion of two-thirds to one-third of the superficial extent, as in a case seen by Schöler.<sup>2</sup>

Only the acceptance of an individual difference in the organization of

<sup>1</sup> *Loco citato*, Fig. 1.

<sup>2</sup> *Beiträge zur Pathologie der Sehnerven und der Netzhaut*, 1884, S. 74.

the optic centre in regard to the situation of the cortical sensory units of the fasciculus non-cruciatatus and the fasciculus cruciatatus, which relation has been described as a "mixture of the small fibre-bundle fields,"<sup>1</sup> can offer any solution of these relationships.

In the symmetrical chess-board-like mixture of the small fibre-bundle fields, inside the region in which in the binocular field of vision the homonymous nasal and temporal halves of the visual fields cover each other, there is, for each small or large disease-focus in the optic path to the hemisphere, an absolute congruous island-like hemianopic defect. If the disease-focus spreads to this region, which stands only in relation to the peripheral zone of the temporal half of the field of vision, relatively congruous hemianopic defects which have the surface relation of two-thirds to one-third in the field of vision are obtained.

An irregular mixture of the fields of the small fibre-bundles, in which large groups of sensory units of the fasciculus cruciatatus lie next to small groups of the fasciculus non-cruciatatus over the cortical surface of the visual centre in the brain cortex, furnishes more or less incongruous hemianopic defects. If the fields of both kinds of sensory units form closed areas, so that an area in the cortical visual perception centre of one hemisphere consisting of sensory units of the fasciculus cruciatatus, and another area composed entirely of sensory units from the fasciculus non-cruciatatus, can be differentiated from each other, then one-sided hemianopic defects are obtained. Nieden<sup>2</sup> describes such a case. The patient, a man, was struck on the head, producing fracture of the occipital bone with injury to the dura mater and the brain. As a consequence a defect appeared in the temporal half of the field of vision of the eye on the side opposite to the injury.

If the disease causing homonymous hemianopsia is unaccompanied by disease of the retina, papilla, or optic tract, and there are no intercurrent disturbances of a purely functional nervous nature, which, as is well known, usually produce concentric diminution of the field of vision and lowering of central visual acuteness, then generally there is no reason why central visual acuteness should not be normal in cases of typical homonymous hemianopsia. In any case, if the central acuteness of vision is not found normal, and if all troubles which might influence it have been excluded, it must be remembered that in old people, who furnish the majority of cases of homonymous hemianopsia, central visual acuteness is itself somewhat diminished. In the face of great diversity of normal visual acuteness, even to a doubled degree, it can be readily understood that individuals with overshoot fields, who therefore have a double innervation of the macula, must have their visual acuteness somewhat diminished in absolute hemianopsia.

Patients in whom the line of separation passes through the fixation-

<sup>1</sup> *Loco citato*, S. 77.

<sup>2</sup> *Archiv für Ophthalmologie*, xxix. 3, 143.

point are more troubled in reading, and, indeed, in any active vision, than those who exhibit an overshoot portion at the fixation-point. In regard to reading, left-sided hemianopsia is more convenient to a patient than right-sided, because in the latter form the end of a word is not yet visible when the fixation-point rests on the commencement of the word.

Small homonymous hemianopic scotomata in the macular region of the field usually cause trouble when attempts are made to read small print, because the letters fall within the region of the defect. With large print very little or no hinderance may be present, and during distant vision little or no complaint is made.

Generally those suffering from homonymous hemianopsia insist that the eye which is on the side corresponding to the homonymous defect is blind. This belief rests on the idea that the right eye sees the right side of an object and the left the left side.

If the statements of such patients are trusted without making perimetric examinations, crossed amaurosis, whose presence in brain-disease foci of one side only has not yet been demonstrated and probably never will be, might be assumed.

In hemianopsias after lesions of the optic path in the hemispheres and the cortical visual centre, the secondary degeneration never, as a rule, extends to the papilla. It generally terminates in the corpus geniculatum externum. Even in lesions of the tract it is often a long time before the descending atrophy passes the chiasm and becomes visible in the papilla. Ordinarily the ophthalmoscope shows a normal fundus in homonymous hemianopsia. There must be wide-spread disease of the cerebral vessels to cause such a condition, as in atheromatous and syphilitic degenerations and in albuminuria, thus giving rise to trouble in the retina as well as in the brain. Sometimes homonymous hemianopsia appears during the course of an albuminuric retinitis, usually the result of an apoplexy.

When in cases of homonymous hemianopsia the peripheral limits of the retained halves of the fields of vision do not possess the normal extent, the following three questions should be immediately taken into consideration: 1. Can changes be made out in the fundus of the eye? 2. Is the ophthalmoscopic appearance of the fundus normal? and, 3. Did the bilateral homonymous hemianopsia cause the shrinkage in the remaining active halves of the fields of vision?

If a patient comes suffering from hemianopsia and marked changes in the fundus oculi for the first time, it is not easy to diagnose the presence of homonymous hemianopsia from the complicated changes in the field of vision. The indication of the complication of the trouble with homonymous hemianopsia is obtained from the sudden onset of increase in visual disturbance, markedly towards one side, and sometimes the addition of other cerebral symptoms. If there is a normal fundus, it should be determined whether the patient is myopic, whether there is hemeralopia, and whether



there is congenital amblyopia of one eye. If there is symmetrical concentric diminution of the retained halves, with similar lessening of the color-limits, then the condition is due to a purely nervous trouble, and there will be probably other hysterical stigmata on the side of the body that is opposite to that of the hemianopsia.

In aged patients with homonymous hemianopsia, in whom the nutrition of the brain has suffered a good deal, irregular shrinkage of the limits of the retained halves of the visual fields is often met with. Sometimes such patients tire so rapidly that perimetric examination is not possible, giving rise to bizarre fields that do not appear hemianopic in type.

Patients with sensory aphasia, or those who are in a semi-conscious state, and in whom a possible hemianopsia should be looked for, are best examined by means of a light, which should not be brought too near, lest the heat be noticed. The light should be placed first on one side, then on the other, and gradually brought towards the point where the patient can fix upon it. Whilst this is being done the patient's eyes should be watched, to see whether they follow the movements of the light. Hemianopsia in such subjects can at times be determined by means of the blinking reflex when, without the patient's knowledge, any object is suddenly moved from one side towards the eyes.

Hemianopsia is seldom seen in children. If such a condition appears in early childhood, the homonymous deficiency may never be realized, because such patients have never seen with any larger fields.

Freund<sup>1</sup> and Silex<sup>2</sup> have described cases of hemianopsia occurring in childhood. In making such examinations the child should be made to gaze at some object, whilst a second one (for instance, a piece of candy) is brought from the side before its eyes. If the second piece comes into the active part of the field the child at once reaches for it, but if the object is moved in the defective portion no notice is taken of it. Such examinations can be made in the binocular field only, for if one eye be covered or bandaged the child becomes fractious, rendering further examination impossible.

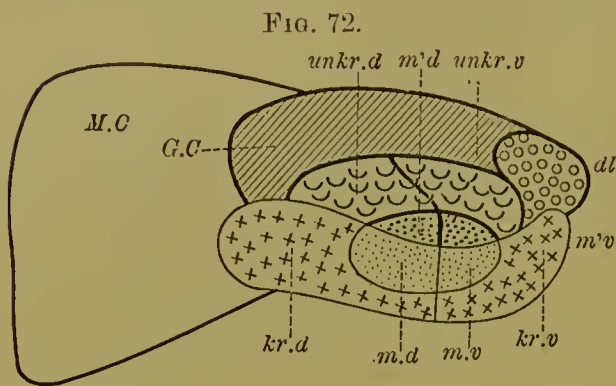
#### HEMIANOPSIA DUE TO DISEASE OF THE TRACT.

The particular nerve-fibre path in the tract, according to Henschen, is: (a) The macular bundle courses centrally in the tract (*m'd*, *m'v*, and *m'v*, Figs. 72 and 73). (b) The uncrossed bundle lies dorso-laterally, forming a close cord (*unkr.d*, *unkr.v*, Figs. 72 and 73). The bundles retain this position until they enter the corpus geniculatum, where they separate into a mass of separate fibres. (c) The crossed bundle (*kr.d*, *kr.v*) lies ventro-medially, and forms a bundle which lies slantingly and hangs loosely together, somewhat in the form represented in the same figures.

<sup>1</sup> Wiener Medicinische Wochenschrift, Nos. 32 and 33, 1888.

<sup>2</sup> Berliner Klinische Wochenschrift, No. 42, 1888.

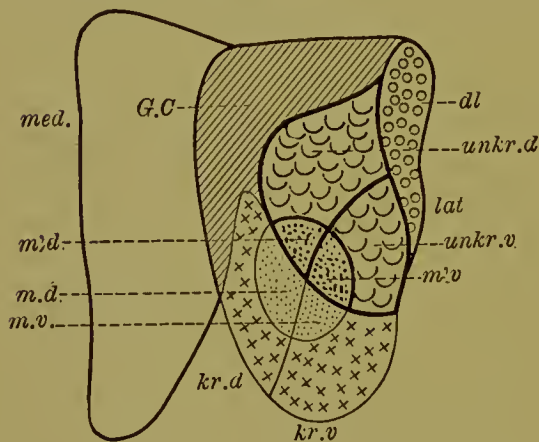
Hensehen had this scheme taken from the appearances seen during the examination of a preparation from a patient suffering from recent atrophy.



There is another dorso-lateral area in the tract (*dl*, Figs. 72 and 73) which contains fibres that have undergone a partial crossing in the chiasm. *M.C* indicates Meynert's commissure; *G.C* shows the relative position of von Gudden's commissure.

When the tract is found filled with small capillary hemorrhages, as described by Weigert<sup>1</sup> and Saenger,<sup>2</sup> large-sized defects in the field of vision may appear. The atrophic conditions in the tract seem never to be of a primary nature, hemianopic disturbances, as the expression

FIG. 73.



of a progressive primary atrophy of the tract analogous to that of diseases of the optic nerves, never yet having been observed. The atrophic conditions in the tract seem, therefore, to be merely of a secondary atrophic nature. Even in multiple sclerosis homonymous hemianopsia is well known to be very rare, Uhthoff<sup>3</sup> not having found a single example among one hundred cases. This is remarkable because in five cases which were examined

under the microscope by Oppenheim,<sup>4</sup> sclerotic foci were found in the orbit, in the chiasm, and in the tract.

Two similar cases of direct injury to the tract by stabbing have been recorded,—one described by Steffan,<sup>5</sup> and a second by Wernicke,<sup>6</sup> in which, after a stab in the left temporal lobe, right-sided hemiplegia and right homonymous hemianopsia, with a slight ptosis of the left upper eyelid, appeared. Hemianopic pupil-reaction was present. The diagnosis was a punctured wound of the left cerebral peduncle at the point where the tract lies against it. The ptosis in each instance indicated that the root-bundle of the levator was affected by the injury.

<sup>1</sup> Virchow's Archiv, lxxv. 221.

<sup>2</sup> Archiv für Psychiatric und Nervenkrankheiten, x. 150.

<sup>3</sup> Ibid., xxi.

<sup>4</sup> Zur Pathologie der disseminirten Sclerose, Berliner Klinische Wochenschrift, xli., 1887.

<sup>5</sup> Klinische Monatsblätter für Augenheilkunde, 1865, 167.

<sup>6</sup> Allgemeine Wiener Medicinische Zeitung, 1890, 48, 49.

Often the tract is pressed on by tumors which are situated in the neighboring portions of the brain. Most commonly these tumors originate in the central ganglia, as in the cases described by Rosenbach, Oliver, Dreschfeld, Norris, and Dereum. A complete clinical history of these cases is given by Heuschen.<sup>1</sup> In a case of Gowers's the tumor grew from the temporo-sphenoidal lobe through the tract into the pedunculus cerebri. Setsina has found a tumor in the gyrus fornicatus which had pressed upon the optic tract.

In a case by Leyden<sup>2</sup> a focus of softening which spread into the pedunculus cerebri and attacked the optic tract was found in the lenticular nucleus of the right side. There were left-sided homonymous hemianopsia and hemianopic pupil-reaction.

For the diagnosis of a purely tract hemianopsia it might well be expected *a priori* that in such a narrow band of fibres, in which all the optic fibres of one hemisphere pass, pressed close together, the usual result would be a complete homonymous hemianopsia. To decide this question statistically a far larger number of indisputable observations of tract hemianopsia than, unfortunately, is at present known of, would be necessary.

From recorded observations it may be concluded that monocular defects of the field, which later become homonymous, point to primary development of disease-foci in the immediate vicinity of the chiasm, whilst primary bilateral homonymous defects, with more or less congruity, point towards the primary focus, being situated in the tract farther towards the centre.

In simple complete tract hemianopsia the color-limits in the retained halves of the fields coincide exactly with the line of separation, and their extent is normal. In the incomplete variety, an analogous color-blind zone, similar to that which has been described in the diseases of the optic nerves, appears. Thus, in Baer's case the perception of light was re-established in the lower right quadrants in spite of the fact that this portion of the field showed no power of perceiving color when examined with a five-millimetres-square colored surface.

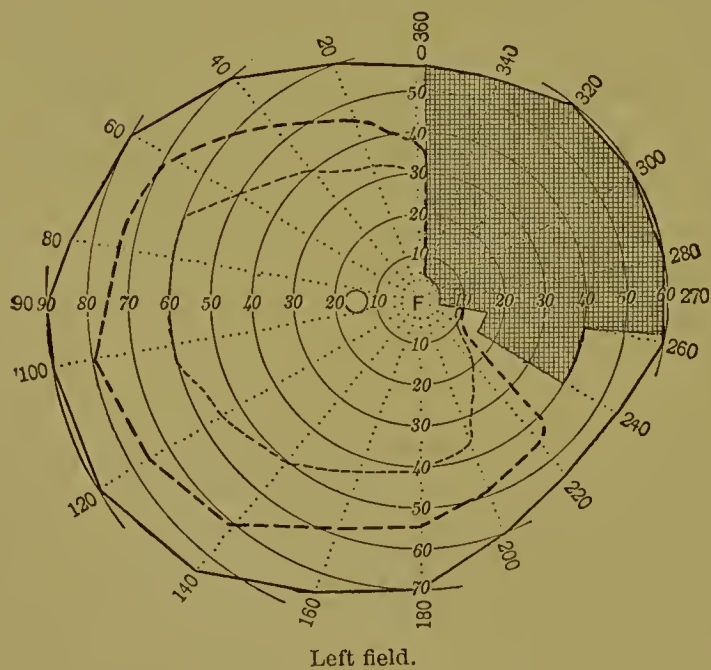
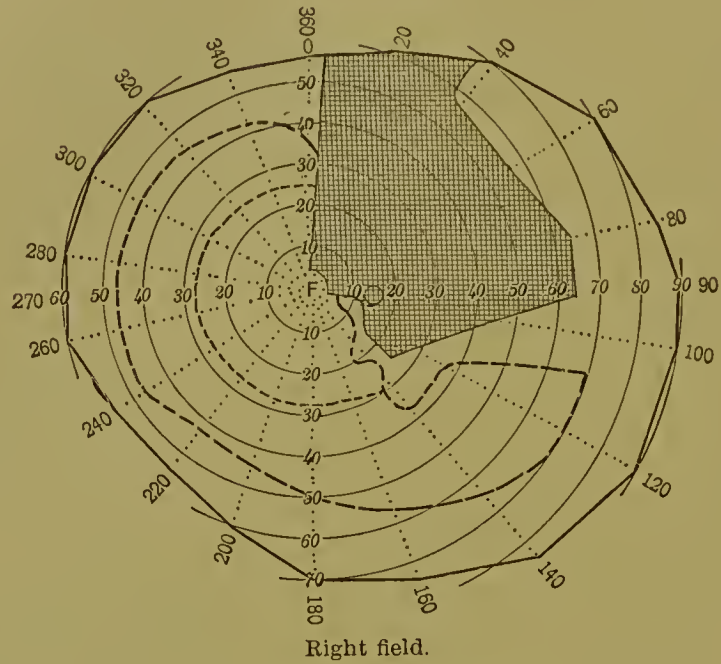
Fig. 74 shows a tract hemianopsia following a basal gummatous meningitis. In this case headache, vomiting, and slight loss of consciousness were followed by the development of weakness of the left leg, left-sided disturbance of sensibility, paresis of accommodation, and ptosis on the right side, with bilateral paralysis of pupil-reflex. There was a slight optic neuritis. At the beginning the absolute defect had the same extent that the limits of blue vision had after three months' time. In the first stages there was a narrow color-blind zone in a downward direction from the absolute defective portion. The half-ring-shaped peripheral zone was added later. All the other symptoms, except a slight weakness of the left leg, disappeared after the use of mercurial inunction. When last seen, the

<sup>1</sup> Loco citato, Bd. ii. S. 267.

<sup>2</sup> Jahresbericht für Ophthalmologie, 1891, 485.

optic conducting path was perfect where the red limits coincide with those of blue. Fig. 74 also shows an overshoot portion of the field along the line of separation with which the limits of the colors coincide.

FIG. 74.



With regard to the development of the defects in the field of vision in lesions of the tract, the following points should be noted :

(a) Bilateral homonymous hemianopsia may develop from the monocular form.

(b) The disease-focus may attack the second tract after it has caused a homonymous hemianopsia in both eyes by lesion of the first tract, and in this manner cause the presence of duplex homonymous hemianopsia.

Oppenheim describes such a case<sup>1</sup> caused by basilar meningitis. First there was typical homonymous hemianopsia of the left side, with narrowing of the retained portions of the fields of vision, this being marked in the left eye. Irregular concentric shrinking appeared only occasionally, indicating the type of hemianopsia, until at last a left-sided homonymous hemianopsia was clearly defined. This change in the symptoms is explained by the rapid growth of the connective-tissue structure of the syphilitic affection, which swells and shrinks alternately, producing changeable pressure.

Russell<sup>2</sup> narrates a case in which a tumor destroyed both of the optic tracts, causing binocular amaurosis.

(c) The disease-process may spread from the tract to the chiasm. Such cases have been spoken of in describing temporal hemianopsia. At the commencement of the spreading of the attack to the chiasm, the retreat of the limit of color-perception from the dividing line, together with the concentric diminution of the color-fields in the retained half of the field of vision of one eye, with unilateral loss of visual acuteness, gives the direction of the progress of the disease. If the disease-process first attacks the papillo-macular bundle, a relative or an absolute central scotoma develops, and the dividing line bends towards the retained halves of the fields of vision in a manner corresponding with the size of the scotoma. The extent of the field for white and colors in the half of the other eye remains, at least in the commencement, normal.

(d) The disease-focus grows from the chiasm to the tract. At first there is temporal hemianopsia. To this is slowly added complete blindness of one eye. This order of symptoms cannot be separated from that which appears when the process spreads to the optic nerve of one side, or when the whole of one side of the chiasm is destroyed.

To recapitulate the diagnostic points of tract hemianopsia. 1. The optic tract may be affected by itself. 2. It is impossible to conclude that there is a tract hemianopsia from the form of the hemianopic field of vision alone. 3. If to a homonymous hemianopsia is added a failing of the visual acuteness of one eye, with a corresponding change in the retained half of the field of vision of this eye, the disease-process has spread to the chiasm. 4. If nasal homonymous hemianopsia is found in one eye and blindness or a high degree of amblyopia in the other, then a disease of the tract on the side of the nasal hemianopic defect of the field of vision is probable. 5. The loss of only one-half of the field of vision of one eye of a hemianopic character, soon followed by the loss of the homonymous half of the field of the other eye, indicates a tract hemianopsia in which the seat of the disease is near the chiasm. 6. The bilateral appearance of incomplete homonymous hemianopic defects, which point to tract hemianopsia, indicates that the point attacked in the tract is situated centrally at some dis-

<sup>1</sup> Zur Kenntniss der syphilitischen Erkrankungen der Central Nervensystems, Berlin, 1890, S. 10.

<sup>2</sup> Schmidt's Jahrbücher, cxxvii. 164.

tance from the chiasm. 7. Weakness of one or more cerebral nerves on one side of the body, with loss of the homonymous halves of the visual fields on the other side, sometimes followed or accompanied by hemiplegia or anaesthesia towards the side of the hemianopic defect, indicates disease of the tract. Often polyuria is associated with these conditions. 8. Hemianopic pupil-reaction in homonymous hemianopsia indicates disease of the tract. 9. A slow development of homonymous defects indicates disease of the tract, whilst hemianopsia which appears suddenly (particularly in previously healthy patients) is often caused by intra-cerebral hemorrhages and emboli. Hemorrhages into the tract are mostly of a capillary nature.

#### HEMIANOPSIA IN LESIONS OF THE PRIMARY OPTIC CENTRES.

By the primary optic centres are understood the corpus geniculatum externum, the colliculus anterior, the corpus quadrigeminum, and the pulvinar.

Although there is no doubt that fibres from the tract pass to each of these ganglia, yet a differentiation between those fibres which serve for actual sense of vision (the visual fibres) and those which serve for reflex transmission from the optic nerve to the other cerebral centres must be noted. In regard to the question whether visual fibres pass to the colliculus anterior and the pulvinar, Nothnagel has found that a lesion of the colliculus anterior is not necessarily followed by visual disturbances. In like manner cases have been recorded which seem to demonstrate that lesion of the pulvinar is not essentially accompanied by disturbances of vision.

All authors are nevertheless agreed that the corpus geniculatum externum is intimately associated with the visual fibres. The ganglion-cell layer of the retina is regarded as the chief point of origin of the fibres of the optic nerve. The axis-cylinder continuations of the centripetal fibres terminate in the primary optic centres and cause the transmission of impulses to the ganglion cells, especially to the peripherally situated ones of the corpus geniculatum externum.<sup>1</sup> At their entry into the outer corpus geniculatum the several bundles of fibres of the optic nerve separate. Henschen has shown that the fibres of the crossed and uncrossed bundles appear to lie close together. They then form in the corpus geniculatum the beautiful bundles which radiate in a sagittal direction. Whether their separation in the corpus geniculatum is of such a kind that distinct portions or layers of the ganglion correspond to certain quadrants of the retina or not is as yet unknown. Probably the homonymous fibres lie close to one another. A projection of the tract fibres over the primary centres takes place. Here an ending of the fibres of the tract appears, and the ganglion-cells giving rise to the conducting fibres for the visual sphere are seen.

Between these two systems of fibres there must be assumed to be a transmuting system of ganglion-cells in the primary optic centres. This system

<sup>1</sup> V. Monakow, *Archiv für Psychiatrie und Nervenkrankheiten*, Bd. xxiv. Heft 1.

should, according to v. Monakow,<sup>1</sup> permit a series of changes and thus cut off isolated conduction. For instance, it is conceivable that in the corpus geniculatum externum the bundle of the tract should excite not only the ganglion-cells which are situated in its immediate neighborhood, but also those which are more distantly situated. This explains the incongruities of the different defects in hemianopsia.<sup>2</sup>

Von Monakow also believes that the key to the cause of the remarkable phenomenon that the macular field so often remains free in homonymous hemianopsia (the overshoot field of vision) is to be found in the arrangement of the primary optic centres. It is conceivable that the fibres in the tract originating in the macula lutea terminate in a different manner in the corpus geniculatum externum from those that do not radiate into a circumscribed region; that is, they end in a scattered manner, corresponding to the importance of the spot for vision,—in fact, in such a way that the macular-fibre bundle takes part in the perception of each section of any picture impressed on the retina. It is clear that it must be assumed that the macular fasciculus is projected indirectly in a corresponding manner into the cerebral sphere of vision, and that this extends to the outermost limits of this sphere, so that the cortical distribution of the macular bundles forms a special sphere included within the actual one. In assenting to these assumptions it must under all circumstances be assumed that if a focus of softening leaves only a small portion of the sphere of vision free, allowing it to act, then excitation of the macula can reach this undestroyed portion, and in such a way that light is still perceived when it impinges on the macular region.

As soon as any slow-growing permanent process of disease appears in the occipital lobe, a secondary degeneration develops through the sagittal medulla from the point of the lesion. This causes those ganglion-cells of the primary optic centre from which the axis-cylinder continuation of the sagittal medulla springs to atrophy.

The focal symptoms of a disease-focus in the primary optic centres are generally homonymous hemianopsia, and hemiplegia and hemianæsthesia of the same side, this being in consequence of the common involvement of the neighboring fibres passing along the internal capsule or the pedunculus cerebri. If the posterior end of the tract is involved, through pressure or softening, the hemianopic pupil-reaction is observed, as in the cases of Oliver<sup>3</sup> and Dercum,<sup>4</sup> and in the earlier recorded ones of Leyden.

In diseases affecting the thalamus opticus, with homonymous hemianopsia and hemiparesis there are hemiplegia and hemiathetosis, as in the cases observed by Dercum and Henschen.<sup>5</sup> Tumors in the neighborhood of the

---

<sup>1</sup> Archiv für Psychiatrie und Nervenkrankheiten, Bd. xxiv. Heft 1, S. 87.

<sup>2</sup> V. Monakow, loco citato, S. 90.

<sup>3</sup> Ophthalmic Review, 1890, 268.

<sup>4</sup> Journal of Nervous and Mental Disease, 1890, 506.

<sup>5</sup> Loco citato, i. 103.

Sylvian aqueduct cause the early appearance of such conditions in association with ventricular dropsy and choking of the optic disks.

Hemianopsia, with loss of the mimetic movements and temporary hemiplegia, is found in disease of the optic thalamus.<sup>1</sup>

Disease of the optic thalamus usually leads indirectly to hemiplegia. If the posterior portion of it, with the pulvinar, is affected, the hemianopsia is observed as an indirect focal symptom. Post-hemiplegic chorea and athetosis are symptoms which ought probably to be regarded as focal symptoms of disease of the optic thalamus. Involuntary movements of the limbs have often been observed in cases of tumor of the optic thalamus. Vaso-motor and trophic disturbances of the paralyzed half of the body and on the side of the hemianopsia should be numbered among the focal symptoms of the disease.<sup>2</sup>

Bouchut<sup>3</sup> relates a case in his article concerning cerebral amaurosis consequent on bilateral disease of the optic thalami. Here there was incomplete paralysis of all four extremities. Walking or standing was impossible. Ataxic movements and tremors occurred when the patient endeavored to use his hands. Marked anæsthesia of the entire skin surface was observed.

#### THE FIELD OF VISION IN LESIONS AFFECTING THE OPTIC FIBRES IN THE CEREBRAL HEMISPHERES.

The intact connection of the external corpus geniculatum of each side with the occipital cortex is of the utmost importance, because the visual nerve fibres pass along this path. Fibres which originate in the corpus geniculatum externum pass to the parietal and temporal convolutions. These, however, do not serve for visual purposes in the proper sense, and therefore a lesion of them does not produce disturbance of vision.

The *visual* fibres originate in the larger cells of the corpus geniculatum, and form a bundle about five millimetres in thickness, which passes anteriorly from the top of the first temporal sulcus. From there they go into the second temporal gyrus and second temporal sulcus, spreading in a radiating manner into the cortex at the top of the calcarine fissure. Inside the occipital convolution this bundle sends two bow-shaped radiations upward and downward to the cortex in the calcarine fissure.

The fibres which originate in the cells of the corpus geniculatum terminate in the cortex. The visual fibre-bundle contains also centrifugal fibres, which originate in the cells of the cortex and terminate in the corpus geniculatum in the same manner. Besides this, fibres connect the occipital convolution with the corpora quadrigemina, the pulvinar, and the external capsule. These fibres, though *optic*, are not *visual* in type. The crossed and the uncrossed fibres probably lie intermixed. According to Henschen,

<sup>1</sup> Rosenbach, Neurologisches Centralblatt, v. 241.

<sup>2</sup> Wernicke, Lehrbuch der Gehirn-Krankheiten, ii. 77, iii. 345.

<sup>3</sup> Gazette des Hôpitaux, No. 149, 1879.



the visual fibres do not pass through the internal capsule, but close underneath it.

It is impossible to determine, from a study of the defects of the field of vision alone, whether a focus of disease is situated in the path of the visual fibres through the hemisphere; for here, according as the whole or a part of the fibres is destroyed, complete or incomplete homonymous hemianopsia results. Attention should be called to the fact that, according to the author's experience, sometimes in foci of disease of the knee or posterior limb of the inner capsule, which occur with hemiplegia and hemianæsthesia, incomplete hemianopsia is seen.

In a case described by the author,<sup>1</sup> in which a small focus in the occipital lobe had indirectly affected the path of optic conduction, the homonymous right halves of the fields of vision were found filled with small scotomata. There was also an absolute scotoma which included the macular portion of the right half of the field of vision. In addition to symptoms of psychic blindness, homonymous hemianopsia should be regarded as one of the focal signs of lesions of the occipital lobe.

According to Knies, the centres for the associated movements of the eyes are situated in the cortex of the occipital convolution; and it is on account of the destruction of these centres by foci of disease in the occipital convolution, he says, that hemianopes read badly, even when there is an overshoot field of vision. A focus in the left temporal lobe which attacks the posterior portions of the temporal convolutions, and which spreads into the brain-substance as far as the descending cornu of the lateral ventricle, causes right-sided hemianopsia with aphasia and right-sided hemiplegia in the majority of cases.<sup>2</sup> Lesions of the cortex and nerve-substance of the angular gyrus and the upper parietal lobe of the left hemisphere usually produce alexia with right-sided homonymous hemianopsia.

In monoplegias with hemianopsia a focus in the parietal lobe which has encroached at a point into the nerve-substance and destroyed the sagittal nerve-bundle should be considered. Hemianopsia may occur with Jacksonian epilepsy in which the foci originally caused the hemianopsia by disease of the occipital lobe. Later, through a spreading of the disease-process to the cortex of the parietal lobe there are unilateral convulsions on the same side as the hemianopsia, without any loss of consciousness.

Westphal<sup>3</sup> says, "Paroxysmal onset of unilateral convulsions, with permanent hemianopsia of the same side, is the result of disease of that portion of the opposite hemisphere which lies behind the anterior parietal convolutions, whether it attacks the cortex or the nerve-substance or both together. Disturbance of the muscle-sense and movement of the arm, together with slight weakening of the sensibility and involvement of a portion of the

<sup>1</sup> Die hemianopischen Gesichtsfeld-Formen, Wiesbaden, 1890, S. 57.

<sup>2</sup> Oppenheim, Jahresbericht für Ophthalmologie, 1886, 299.

<sup>3</sup> Charité-Annalen, vii. 466.

face, doubtful weakening of the mimetic movements of one side of the face, and homonymous hemianopsia of the same side, are to be regarded as conclusive signs of a disease limited to the cortex of the hinder part of the parietal convolution, both parietal lobes, and extending slightly into the temporo-sphenoidal convolution and occipital lobes."<sup>1</sup>

The pupils give no hemianopic reaction when the hemianopsia results from disease situated centrally from the primary centres, as shown by Renvers.<sup>2</sup>

Flashes of light in the lost halves of the fields of vision are occasionally observed in the early days, after the onset of a hemianopsia that is due to intracerebral disease-foci. Their occurrence might be used in the differential diagnosis from homonymous hemianopsia following destruction of the optic centre in the brain cortex. The reason for this is that the flashes of light cannot possibly occur after the destruction of the centres, because the perception of every quality of light (subjective and objective) is brought about by means of the perception centres.

In cases of homonymous hemianopsia consequent on lesion of intracerebral optic conduction, the same individual relations of the line of separation with regard to the overshoot visual field are met with as in lesions of the tract. In a case of Baumgarten's<sup>3</sup> the line of separation lay in the vertical meridian between the two halves of the visual fields, and cut through the fixation-point; whilst in other cases, of which Wernicke's<sup>4</sup> is an example, the line of separation was placed some distance from the fixation-point.

Zones of deadened perception, in which colors can no longer be recognized, may be observed, as seen in Förster's case.<sup>5</sup>

#### CORTICAL HEMIANOPSIA.

According to Hensehen, the visual centre is situated in the cortex of the calcarine fissure. It is not certain whether the most anterior and posterior portions of this space must be included or not. The lateral extent of this centre upward and downward is such that a strip of some millimetres over the surface of the cuneus and the lobulus lingualis is recognizable. The cortex of the upper surface of the fissure corresponds to the dorsal half of the retina, that of the lower surface to the ventral half. The macular portion probably lies towards the front, and the peripheral area is situated nearer the occipital point.

The crossed and uncrossed bundles do not terminate, as Munk assumes, in separate large areas, but the fibres of the homonymous halves of the retina end close together. The dorsal and ventral fibres of the sagittal nerve-bundle terminate in the macular area of the cortex of the calcarine fissure.

<sup>1</sup> Westphal, *Charité-Annalen*, vii. 466.

<sup>2</sup> *Deutsche Medicinische Wochenschrift*, 1888, xvii. 372.

<sup>3</sup> *Centralblatt für die Medicinischen Wissenschaften*, 1878, 21.

<sup>4</sup> *Virchow's Archiv*, lxxxvii. 335, 1882.

<sup>5</sup> *Graefe und Saemisch, Handbuch der gesammten Augenheilkunde*, vii. 118.

It remains uncertain whether color-perception is produced by the same cells that cause light-perception, and whether the centre for color lies in another layer than that intended for the perception of light, because up to the present time no anatomical observations have been recorded. At any rate, the cortical color-centre does not lie in the ventral cortex, as was formerly assumed. The centre for perception of position in space, in the same sense as the centres for light- and color-perception, probably does not exist, for the sense of position in space is caused by several references to the action of the muscles of the eye, etc., whose central point Knies<sup>1</sup> places in the cortex of the occipital lobe.

The theory of von Monakow and of Vialet, of a movable centre of vision, has gradually lost all clinical and anatomical support. A lesion of the central division of the cortex of the calcarine fissure calls forth a permanent defect in the visual centre, and no other portion of the cortex area can officiate for the destroyed centre. On the other hand, the macular retinal region often receives a double innervation,—*i.e.*, from both hemispheres. To a certain extent it may be said that there is a cortical retina.<sup>2</sup>

Disease of the optic centre in the cortex may occur without any other focal symptoms. A partial destruction of cortex area, as in the case of Hun,<sup>3</sup> may cause simply an incomplete homonymous hemianopsia. Unfortunately, however, the focus is usually not limited to the cortex only, but spreads into the nerve-substance. After destruction of the cortical centre neither flashes of light nor hallucinations of vision can appear in the half of the visual field which is connected with the destroyed centre. Still, before this assertion can be implicitly accepted, further research must be made.

Cases are known in which, as in apoplexy, the color-perception of the homonymous halves of the fields of vision is lost, whilst the peripheral extent of the field for white and the central and peripheral acuteness of vision of homonymous color-blind halves of the visual fields are not altered, or only to an unimportant degree. In this connection attention may be called to the cases of Samelsohn,<sup>4</sup> Steffan,<sup>5</sup> and Alexander,<sup>6</sup> in which the acuteness of vision and the visual field for white remained normal for years after an apoplectiform hemianopic color-blindness (so-called color-hemianopsia) had appeared as bilateral color-blindness in eyes which had formerly good color-perception. This peculiarity of the sudden and permanent loss of the power of color-perception in both eyes, or in the homonymous halves of the two fields, whilst the eccentric acuteness of vision and the extent of the fields of vision for white (when examined with a white

<sup>1</sup> Grundriss der Augenheilkunde, ii. 89.

<sup>2</sup> Vide Oliver, American Journal of the Medical Sciences, Jan. and April, 1885.

<sup>3</sup> Centralblatt für Klinische Medizin, 1888.

<sup>4</sup> Centralblatt für die Medicinischen Wissenschaften, 1881, 47, 50.

<sup>5</sup> Archiv für Ophthalmologie, xxvii. 2, 1881.

<sup>6</sup> Ibid., xv. 3, 102.

five-millimetres-square object) are normal, can be explained only by the sudden separation of that portion of the cortical surface which affects the power of the perception of color, without any destructive interference with the ganglion-cells in which the perception of light originates.

The author has studied these relationships, and has asserted<sup>1</sup> that the so-called centre for color-perception must be situated in the outer cortical layers of the visual centre, and over that cell-region which appeared as the centre for "clear-sight perception." The case shown by Verrey,<sup>2</sup> in which the disturbance was caused by a lesion of the occipital lobe close under the cortex of the calcarine fissure, is not clear, and fails to affect this belief, because the power of perception of light was reduced to one-eighth of the normal. The author has found a case by Oppenheim<sup>3</sup> in which following a fracture of the left side of the occiput there was the single cerebral symptom of right homonymous color-hemianopsia. Bardeleben trephined, chiselling off the affected portions of the bone. A marked depression was found, with several splinters and hairs situated in the deepest part. The bone was removed. The dura mater was not opened. The result was successful as to the patient's general condition, but the color-hemianopsia remained unchanged.

More such cases must be observed and carefully examined.

Mackay<sup>4</sup> has well criticised the cases which had occurred up to the time of the appearance of his paper. He recommends the following method of determining perimetrically the eccentric acuteness of vision in these cases, which is well worthy of adoption. Upon one side of a white card eight and a half centimetres long and two centimetres broad two black squares each one and a half centimetres wide are so fastened that a white space three centimetres wide separates them. At the side of the black squares a white margin of the card remains. Upon the back of the card a strip of black eight and a half centimetres long is fastened so that it covers the white card from the lower margin to the same height as the black square on the face of the card reaches. This examining object is pushed from the outer and inner margins of the perimeter towards the fixation-point, and frequently reversed so that alternately the black rectangle and the two black squares of the other side are turned towards the patient. The subject must tell in order (1) the moment that the object comes into the field of vision; (2) which of the two conditions appears, white or black; (3) whether one or two black spots are to be seen, and, lastly, (4) the form that the spots and rectangle assume. As soon as the patient answers one of the questions, the point upon the perimeter arc at which the test-objects are seen is noted on a scheme of the field of vision. For determination of the peripheral visual acuteness the points are said to be proportionate when

<sup>1</sup> Wilbrand, *Ophthalmiatische Beiträge zur Diagnostik der Gehirn-Krankheiten*, 1884.

<sup>2</sup> *Archives d'Ophtalmologie*, 1888, Juillet, Août.

<sup>3</sup> *Verhandlungen des X. internationalen medicinischen Congresses*, Berlin, Bd. iv. S. 2.

<sup>4</sup> *British Medical Journal*, Nov. 10, 1888.

the patient is able to state whether he perceives one or two of the squares. In this manner every meridian of each half of each field of vision is examined, a good comparison between the peripheral perception of space (visual acuteness) of the healthy and color-hemianopic halves of the visual fields being obtained.

The following examination serves as a control. An object from one to five centimetres square is left white upon one side. Upon the other side a black triangle is so fastened that its base embraces one side and its apex touches the centre of the opposite side of the square. The eyes are examined, and the results are set down on a scheme, as follows: (1) where the object enters the field of vision; (2) where it appears white, or black and white; and (3) where the form of the black triangle is recognized.

There remains to note specially that lesions in the visual tract in the occipital lobe—for instance, in disease-foci in or under the parietal lobe of the left side—cause alexia with disturbances of color-perception, reminding one strongly of color-hemianopsia in the homonymous halves of the fields of vision. This condition, however, may not be regarded as pure color-hemianopsia in its strict sense, for the reason that in the known cases the eccentric acuteness of vision and perception of light were altered in a high degree.<sup>1</sup>

A peculiar disturbance which is known by the author as *amnesic color-blindness*, and which is at times found in right-sided homonymous hemianopsia with aphasia, consists in the patient's not being able to name, or in his naming wrongly, colors that are held before his eyes. When examining with the perimeter, this circumstance might easily lead to the assumption that an alteration of the color-sense is present. Such patients are merely not in condition to find spontaneously the word which belongs to the color set before their eyes. If bundles of colored wools are placed before them, and they are set to sort the colors which belong together, they do it without hesitation or fault, thus proving that the color-sense is normal and that the disturbance is one that belongs to the aphasic symptom-complex. The author has described such cases.<sup>2</sup>

#### HEMIANOPSIA HOMONYMA DUPLEX.

If right- and left-sided homonymous hemianopsias occur in the same patient, then the loss of the homonymous right and left halves of the visual fields of both eyes causes absolute bilateral blindness, just as if the right and left optic conducting paths from the chiasm had been destroyed at any two points. If in this condition the disease-focus in both hemispheres attacks the optic conducting path on the other side of the primary optic centres, and if there is no indirect pressure exerted on the primary optic centre, the pupil-reaction of both eyes remains intact, notwithstanding the

<sup>1</sup> Compare Verrey, *Archives d'Ophthalmologie*, 1888, Juillet, Août; and Eperon, *Archives d'Ophthalmologie*, 1888, Juillet, Août.

<sup>2</sup> *Ophthalmiatische Beiträge zur Diagnostik der Gehirn-Krankheiten*, 1884, S. 28.

presence of absolute amaurosis. In contrast to this, if the optic tract is destroyed on one side, and the optic path in the hemisphere or the optic perception centre in the cortex on the other has lost its function, a hemianopic pupil-reaction is obtained, notwithstanding the bilateral absolute blindness and the loss of the pupil-reaction on exposure to light-stimulus.

If a lesion occupy the situation of the primary optic centres on both sides, the pupil-reaction on both sides will fail with the occurrence of sudden bilateral blindness. Peltzer<sup>1</sup> has described such a case in which post-mortem section showed embolism of the basilar artery, with foci of softening in both optic thalami, the corpora quadrigemina, and the occipital lobe.

A sudden onset of bilateral lesion of the tract, in which pupil-reaction is wanting, has not yet been observed.

Dojne<sup>2</sup> mentions a case in which a temporary right-sided homonymous hemianopsia lasting fourteen days occurred, followed by a left-sided homonymous hemianopsia. At the post-mortem examination disease-foci were found in both occipital lobes.

Occasionally patients suffering with homonymous hemianopsia state that they were entirely or almost entirely blind for some seconds, or even for hours, after their attack, followed by a slow return of power of vision upon one side. In such instances probably a large hemorrhage has destroyed the optic perception centre of one hemisphere at its median surface, and exerted a pressure on the centre in the other hemisphere, by which the first one affected was temporarily stopped from functional activity.

Bilateral hemianopsia, with blindness, may occur suddenly, without any further focal symptoms, as a case of Bouveret's, in which a post-mortem was made, shows. Unilateral or bilateral paralytic symptoms, with disturbances of sensation and aphasic symptoms, are associated with the sudden onset of blindness, according as other brain paths or cortical centres are unilaterally or bilaterally involved.

When an apoplectiform bilateral blindness in which the conditions point to a cerebral lesion appear, the following points when making a prognosis should be considered. The primary bilateral blindness changes to normal vision. In this case the foci, which occur in each hemisphere, press only temporarily on the optic conduction path, without destroying it. Here also the bilateral blindness might be considered as an indirect bilateral focal symptom. Again, one optic centre may be destroyed and the other only temporarily pressed upon. In this case, after a few days, a right- or left-sided complete or incomplete homonymous hemianopsia will ensue. Again, an original attack of blindness may produce right- or left-sided hemianopic defects.

All forms of defect which are observed in simple homonymous hemi-

---

<sup>1</sup> Berliner Klinische Wochenschrift, 1872, 47.

<sup>2</sup> Ophthalmic Review, 1889, 377.

anopsia may appear in the most diverse combinations in bilateral homonymous hemianopic cases. Limiting the study and analysis to those examples which have been described with special regard to defects of the field of vision up to the year 1894, the following groupings are met with : I. Absolute defects in both homonymous halves of the visual fields. II. An absolute defect in the homonymous halves of the visual field in one direction, whilst an incomplete defect occurs in the homonymous halves of the other visual field. III. Defects in the fields of vision which are complete and absolute in both homonymous halves ; or complete and absolute in the homonymous halves in one direction and incomplete in the other ; or incomplete in the homonymous halves in both directions. To the first group belongs Steffan's case,<sup>1</sup> in which apoplectiform bilateral color-hemianopsia with normal visual acuteness occurred (bilateral homonymous hemianopsia). An analogous case has been seen by Alexander.<sup>2</sup> In a case seen by Hoche<sup>3</sup> the lower halves of the fields failed as far as the horizontal meridian. Inside the limits of these defects perception was incompletely lost, and in these portions photopsia and visual hallucinations occurred. Schöler<sup>4</sup> has seen an interesting case in which the loss of the right halves of the fields of vision was such that there was only bare perception of light left, whilst there was a color-hemianopsia in the left remaining homonymous halves. There were also tongue-shaped defects in the upper quadrants of the right homonymous halves, with a narrow peripheral active zone that extended as far as the vertical line of separation.

In Quaglino's case<sup>5</sup> apoplectiform blindness first occurred. Later there was only an absolute defect in the upper left quadrants of each eye, the rest of the fields, with the exception of a color-blindness which remained permanently, recovering completely.

Schöler's and Quaglino's cases to a certain extent form a separate section in Group I., because small absolute defects in the homonymous halves in one direction occurred in them.

To Group II. belongs a case of Siemerling's.<sup>6</sup> Here complete homonymous hemianopsia of the right side occurred suddenly, whilst in the left halves a color-hemianopsia was present.

The following cases belong to Group III. In one seen by Schweigger<sup>7</sup> there was a complete hemianopsia on the left sides of the fields of vision. In the homonymous right halves only a portion of the upper quadrants had failed. Sachs<sup>8</sup> notes an instance in which absolute homonymous hemi-

<sup>1</sup> Archiv für Ophthalmologie, xxvii. 2, ii.

<sup>2</sup> Ibid., xv. 3, 102.

<sup>3</sup> Archiv für Psychiatrie und Nervenkrankheiten, Bd xxiii. Heft 1.

<sup>4</sup> Loco citato.

<sup>5</sup> Giornale d'Oftalmologia italiano, 1867.

<sup>6</sup> Archiv für Psychiatrie und Nervenkrankheiten, Bd. xxi. Heft 1.

<sup>7</sup> Archiv für Ophthalmologie, xxii. 3, 305.

<sup>8</sup> Wiener Klinische Wochenschrift, 1888, 22, 23.

anopsia of the right side was present. In the homonymous left sides of the visual fields the upper quadrants temporarily failed. Swanzy and Werner<sup>1</sup> have seen instances in which both left upper and right lower quadrants were lost. Groenouw<sup>2</sup> has represented the scheme of an analogous field of vision in which in addition there were small homonymous hemianopic scotomata in the lower left quadrants. In a case by Doyne<sup>3</sup> there was at first a complete right homonymous hemianopsia. This condition having been recovered from, an incomplete absolute hemianopsia appeared in the upper quadrants of the left halves of the visual fields. A post-mortem examination was made. In a patient studied by Moeli<sup>4</sup> a left-sided complete homonymous hemianopsia was present. Large objects could be imperfectly perceived in the right halves of the fields. Later, almost complete blindness ensued. There was also a small portion of the field in the macular region of the right side in which a deadened perception remained stationary for some time. A post-mortem description is given.

A case which Förster describes<sup>5</sup> is interesting. A complete right homonymous hemianopsia appeared in a man forty-four years old. The dividing line between the defective and active portions of the fields passed round the fixation-point of both eyes in such a manner that it reached beyond the horizontal meridian two degrees in the right halves. It also lay slightly above and below the horizontal meridian, and somewhat to the right of a perpendicular line drawn through the fixation-point. There was an overshoot portion of visual field in the region of the macula. Vision was almost normal. Four years later an absolute left homonymous hemianopsia appeared, so that only a small central portion remained active. This little area extended to the right of the fixation-point in the horizontal meridian of each field about one degree and to the left two degrees below from the fixation-point. In several other meridians it reached from two degrees to two and a half degrees to the right. Upward from the horizontal meridian there was no field. The field was obtained by a white square object one and one-half millimetres wide. Absolute color-blindness was present in this very small visual area.

Absolute blindness might naturally have been expected to result from the second attack, and the query arises, How was such a small central field of vision retained? After the first attack it is clear that there was an overshoot portion of the field of vision in the macular region, which reached towards the right two degrees beyond the fixation-point. From this circumstance it may be assumed that when the left halves of the visual fields first became defective there was an overshoot portion of the field situated towards the left, which was present as an organic part of the right halves of the

---

<sup>1</sup> Ophthalmic Review, 1890, p. 369.

<sup>2</sup> Archiv für Psychiatrie und Nervenkrankheiten, xxiii. 2.

<sup>3</sup> The Lancet, 1889, ii. 1062.

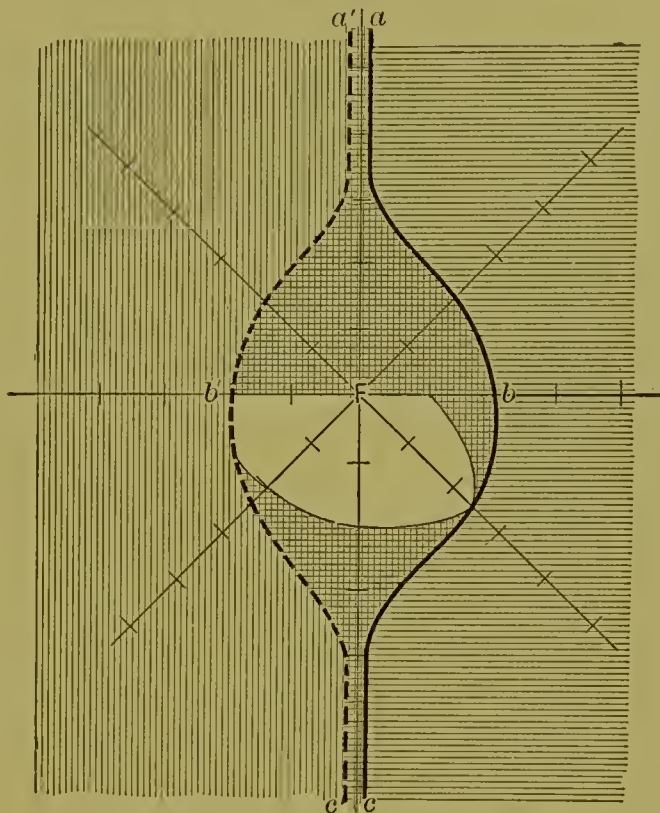
<sup>4</sup> Archiv für Psychiatrie und Nervenkrankheiten, xxii. 99.

<sup>5</sup> Archiv für Ophthalmologie, xxxvi. 1, 94.



visual field, and which reached two degrees beyond the fixation-point into the left halves of the visual fields. In the beginning, however, there was a right-sided incomplete homonymous hemianopsia that contained a remnant of the active portion of the visual field, which reached one degree in the horizontal meridian towards the right beyond the fixation-point and two degrees towards the left. This area had an extent of two and a half degrees towards the lower part of the field. This small remnant in the right homonymous halves of the right field that alone remained active (shown in Fig. 75, in which the double-lined portion is the space of the

FIG. 75.



Scheme showing overshoot macular fields.

double-innervated portion of the macula) became covered in consequence of the overshoot macular portion (*abc*) of the homonymous left halves, and hence could be brought into provable existence only when the left homonymous halves were lost four years later.

That such small remnant of the visual field may remain active in homonymous hemianopsia is proved by the following case which the author has observed. A man, forty-two years old, who had suffered from syphilis some years before, became suddenly paralyzed on the right side and had a right-sided homonymous hemianopsia. He recovered from the paralysis. The ophthalmoscopic condition was normal. Acuteness of vision was almost normal. The dividing line lay exactly in the vertical meridian, the color-vision limits coinciding with it. The right halves of the fields, with the exception of a small macular portion, were lost. The retained central area was cut in an upward direction exactly in the horizontal meridian,

and extended from the fixation-point eight degrees towards the right side, being situated between this and the one hundred and fortieth meridian. It formed a triangle whose base lay in the eighth parallel circle towards the right, and whose apex was situated towards the vertical meridian. It passed beyond the fixation-point by a width of two degrees in the vertical meridian. There was a color-blind zone between the line which sharply cut off the color-field limits in the vertical meridian of the left halves which were active and situated towards the right. Two degrees to the right of the fixation-point there was a deadened area for red and blue. Schweigger<sup>1</sup> has described an analogous case of bilateral homonymous hemianopsia in which a macular remnant of the field of vision, having an extent of from two to three degrees, and in which color-perception was present, was retained.

Sometimes bilateral hemianopsias of this kind are accompanied by disturbances of the perception of position in space, as in Förster's and Groenouw's cases, or with psychical blindness, as in Quaglino's and Siemering's cases, as well as in one described by the author.<sup>2</sup>

Homonymous hemianopsia is not observed in the so-called purely nervous diseases, except under the name of amaurosis partialis fugax (scotoma scintillans, or hemianopic glimmer scotoma), which lasts a short time and to a certain degree must be placed among the functional disturbances. The condition is most likely to be the result of a passing spasm of the vessels in the region of single cerebral arteries. It may be well conceived that, in consequence of sudden alteration of the condition of nourishment of the optic paths, such a stimulus which is conducted to the optic perception centres and there causes lively photopsias may be set free. The continuation of the nutrient disturbance, with the diminished capacity of conduction in the paths, calls forth a scotoma which increases in size, and at its margins the flashing of light continues because adjacent fibres are placed in a condition of excitation.

Mauthner<sup>3</sup> believes that the conduction by the tract fibres is interrupted at some definite point, and at the same time the end of the tract at this spot which is connected with the intact centre is excited, and hence, in addition to the defect, peculiar subjective light-symptoms are called forth.

In an epileptic case seen by the author<sup>4</sup> there was loss of the homonymous left lower quadrants of the fields of vision, followed by a loss of the entire left halves. During the first day the attacks occurred at irregular intervals. On the second day they appeared every quarter of an hour. The third day there were epileptic seizures, which caused the patient to pass into a condition of status epilepticus, during which he died. Post-mortem ex-

<sup>1</sup> Archiv für Augenheilkunde, 1890, xxii. 336.

<sup>2</sup> Die Seelenblindheit als Herderscheinung und ihre Beziehungen zur homonymen Hemianopsie, zur Alexie und Agraphie. Wiesbaden, 1887.

<sup>3</sup> Gehirn und Auge, Wiesbaden, 1881, p. 513.

<sup>4</sup> Ueber Sehstörungen bei functionellen Nervenleiden, Wilbrand und Saenger, Leipzig, 1892, S. 44.

amination showed an extreme congestion of the brain and its vessels, which was most marked in the occipital lobes. Over this region the pia mater was separable with great difficulty. This case shows that scintillating scotomata, which are usually so harmless, may precede some severe nervous disease,—a point to which Charcot has already called attention, at the same time citing a very interesting case. Generally the attacks last but a short time, and this accounts for the want of published accounts of the visual fields. The patients usually come to the physician when the attack is over. As scotoma scintillans occurs both unilaterally and bilaterally, and as in the latter cases it leads to blindness, such cases should not be mistaken for the bilateral hemianopsia that appears as an indirect focal manifestation in both hemispheres.

#### THE FIELD OF VISION IN FUNCTIONAL NERVOUS DISTURBANCES.

In nervous subjects visual disturbances, such as the appearance of small clouds and the rapid tiring of the eyes when doing near work, so that, for example, letters run together and disappear, are troublesome symptoms. At the same time there may be complaints of photopsia, visual hallucinations, sudden onsets of monocular and binocular double vision, pain in the eye and orbit, attacks of seeing objects larger, smaller, nearer, or farther than they actually are, with tears in the eyes, and blindness on exposure to light. The ophthalmoscopic condition and pupil-reaction are perfectly normal. With this symptom-complex, which is known as nervous asthenopia, certain pathological phenomena are almost invariably associated, the knowledge of which is of the greatest importance to the physician. This is so, on the one hand, because the whole symptom-complex may be mistaken for signs of severe organic lesion of the hinder portion of the visual nerve-tract, without any ophthalmoscopic symptoms in a series of cases; and, on the other hand, because it may be confounded with organic lesions of the cerebro-spinal nerve-system and of the optic tracts themselves.

With regard to the changes in the field of vision, two groups of visual field changes can be differentiated: (*a*) general concentric shrinkage, and (*b*) symptoms of weariness in the field of vision. Both these are only different degrees of intensity of the same condition.

(*a*) When such a field is examined with the usual white surface five millimetres square, it appears evenly reduced. It varies in size from almost normal to a reduction of the fifth degree. The field of vision is assumed to be shrunken in a high degree if its peripheral extent does not pass beyond the fifteenth parallel circle.

While the organic lesions of the visual nerves usually cause irregularities and sector-shaped gaps in the outline of the limiting margin of the field of vision, the limits of the field of vision give, on the contrary, by functional nervous disturbances, a non-toothed form corresponding to the diminution of the field of vision for white test-objects. The limits for colors also show a relative diminution. In some cases of general moderate

diminution the limits for red and for blue, as Charcot has observed, are seen approaching each other very closely, coinciding with or crossing each other.

In cases of concentric diminution where the shrinkage is great, the color-limits may almost coincide with those for white. There is a weakening of the power of distinguishing colors, so that small colored objects are not correctly perceived. Thus, blue appears gray and red may seem brown. Acuteness of central vision seems to be greatly lessened. The sense of orientation is retained. If the field be examined with intensely lighted large objects, it will be found to have increased evenly in all its meridians: in fact, electric sparks are recognized at the periphery. If the subject is made to fix a certain point accurately for some time, the periphery changes quickly from clear vision to a vague appearance of fog, thus being brighter on the side towards the light and darker on the other side. If the vision is kept firmly fixed on one point for some time, the fixation-point becomes lost and the whole field of vision appears as if covered with a bright fog. This process, which occurs under physiological circumstances in every person, occurs in such subjects in a markedly brief period of time; that is, such individuals adapt themselves (in Aubert's sense) very slowly. The author has demonstrated this by a series of examinations on a number of patients with a Förster's photometer. This peripheral fog is the result of rapid tiring of the retinal substance, and results only when a small point is accurately and continuously fixed by the eye. In this way light and shadow cannot alternate on the surface of the retina, and the affected portions of the retina have no chance to recover themselves as they do in the processes of assimilation when light and shadow alternate. (Hering.)

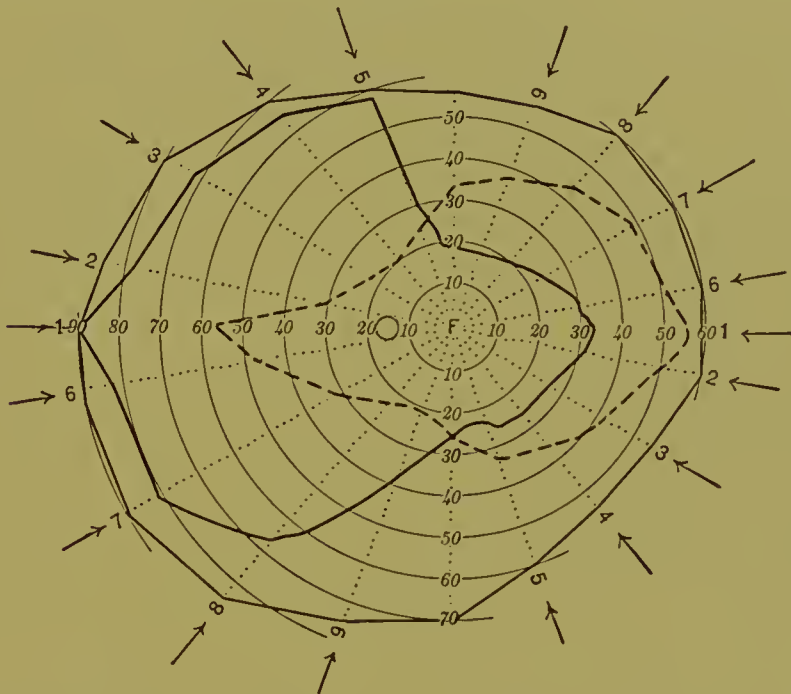
If the functional disorder is of recent origin, the size of the diminution of the field is to a certain extent changeable, so that upon some days the shrinkage appears greater than upon others. Often the degree of diminution is the same in both eyes. In these cases there are disturbances of cutaneous sensibility which are much more marked on the side of the body where there is the greater diminution of the field. Rarely there may be an apparent concentric shrinkage of one field only. Charcot has observed concentric shrinkage of the field of vision lasting without change for thirty-eight years in an hysterical patient.

(b) The symptoms of *too rapid appearance of exhaustion in the field of vision* should be regarded as a slighter degree of such conditions, and, therefore, easier of response to therapeutical measures. Objects directly or indirectly fixed rapidly become indistinct and disappear,—a condition that becomes troublesome when the eyes are used continuously for near work. In the year 1877 Förster first called attention to this abnormal condition of exhaustion, and recommended the method of examination now known as "Förster's displacement type," which consists in using a white examining object, and then, beginning on the vertical meridian, bringing the test-object from the periphery of the field of vision on the temporal side

with equal rapidity across the field in all its meridians to the nasal side, and noting the points of recognition and disappearance.

If the functional nervous disturbance has the form of the too ready exhaustion of the retina, then the succession of figures will present a type (see Fig. 76) which in the meridians that exhibit the temporal half (the first part examined) possess a larger area than the nasal half. This is so because in the region of the latter half the retina had become exhausted. After a slight period of rest, during which the patient must keep the

FIG. 76.



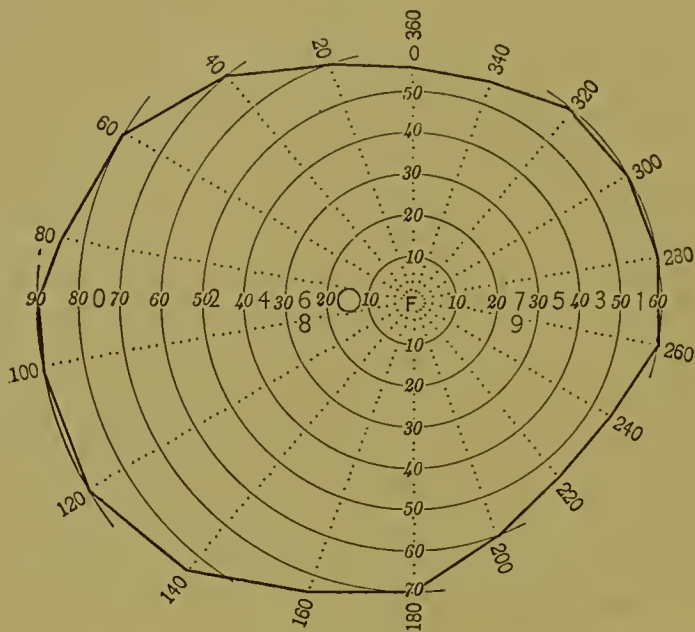
eyes shut, the so-called "control examination" is made reversedly in the same meridians and in the same succession. In this way a second field is obtained whose greatest extent is on the nasal side, because this was the less exhausted half of the patient's retina during this examination.

The author has modified this somewhat clumsy and prolonged method of examination in the following manner. The white examining object, beginning at the temporal margin, is passed along the horizontal meridian (that being the meridian of greatest extent) regularly and slowly towards the nasal margin. An assistant is then to mark the point where the object is first perceived as O on the form (see Fig. 77), and the point where it disappears as 1. This action is reversed, and the point on the temporal side where the object disappears from the field after the second tiring movement is designated on the form by the number 2. Then the first movement is immediately repeated, and the point where the object disappears is marked on the nasal side with the figure 3. If the points do not lie inside one another, in consequence of the exhaustion of the retina not producing any decrease in the extent of the field, the figures are marked one over the other on the form. In this manner it can be determined whether

the field is evenly diminished at first, in which half of the field the exhausting process acts most rapidly, and to what parallel circle the field may be diminished by increasing exhaustion.

In all such exhausting examinations it is shown that the field of vision becomes at first more rapidly exhausted in the temporal half than in the nasal half, and that the nearer the fixation-point the less is the shrinkage. In order to avoid mistakes in the examination, at least as far as is practicable in clinical examinations, care must be taken that the patient fixes the point on the perimeter, and that there is as little closing of the eyelids as possible.

FIG. 77.



It must be understood that any other meridian than the horizontal one may be used for the examination, because if the condition of ready exhaustion is present it shows itself equally over the whole surface of the retina.

These subnormal appearances of a ready exhaustion are caused by the rapid diminution of excitability in the visual substance of the retina as compared with what is present in physiologically normal subjects. In these latter the recovery (assimilation of Hering) of the used material (dissimilation of Hering) during the action of the light upon the retinal substance in a measure spontaneously continues, so that the excitability of the retina remains at one stage continuously, thus under ordinary circumstances satisfying the requirements of vision. A lessening of the recovery of the used material produces a rapid diminution in the excitability and a condition of uselessness in the visual substance of the retina, from which condition the symptoms of nervous asthenopia (anæsthesia retinae, hyperæsthesia retinae) may arise.

As the recovery of the visual substance depends upon the replacement of the used material, so a process of assimilation which is slower than usual must delay such a recovery of substance. That this is so in a large series of cases of functional nervous disturbance possessing evenly spread con-

centric diminution of the field of vision, especially where there is shrinkage due to exhaustion, can be proved by means of Förster's photometer. Whilst the normal eye, after the usual stay in a bright light, takes one minute to see the string-table of Förster's photometer through an opening in a two-millimetres-square diaphragm, subjects suffering from general concentric diminution of the field caused by purely functional nervous disturbances find it necessary to take ten minutes' or even a half-hour's rest in a darkened room to recover a degree of vision equal to that obtained by the normal eye. If such subjects were adapted (in Aubert's sense, for Hering places the attainment of the condition of morbid equilibrium under adaptation), and they were placed with the proper precautions in front of a perimeter, the field of vision would be found to be nearly or quite normal.

In some subjects whose assimilation processes are retarded during the time they keep the eye fixed on the fixation-point in the perimeter and when they are examined with a white object of the regular size, there is an even concentric loss of the peripheral portions of the field of vision. If the strength of the excitation be increased,—for instance, by using a larger examining object,—the extent of the field of vision under otherwise like conditions will appear larger. If a less intense examining object—for instance, a colored one—be employed, a reduction of the color-limits will be found. Thus it will be seen that in the purely functional nervous disturbances there is a relative reduction in both the white and the color fields.

Usually, if normal or only slightly contracted limits to the field of vision are commenced with, symptoms of exhaustion can be established. Further, if it be desired to call forth exhaustion symptoms of diverse type, no attempt should be made when the patient is already exhausted; and, finally, it will be found that the exhaustion in the peripheral parts of the temporal halves of the field takes place more rapidly than it does in the peripheral portions of the nasal halves, upon account of the peripheral portion of the temporal halves lying farther away from the fovea centralis.

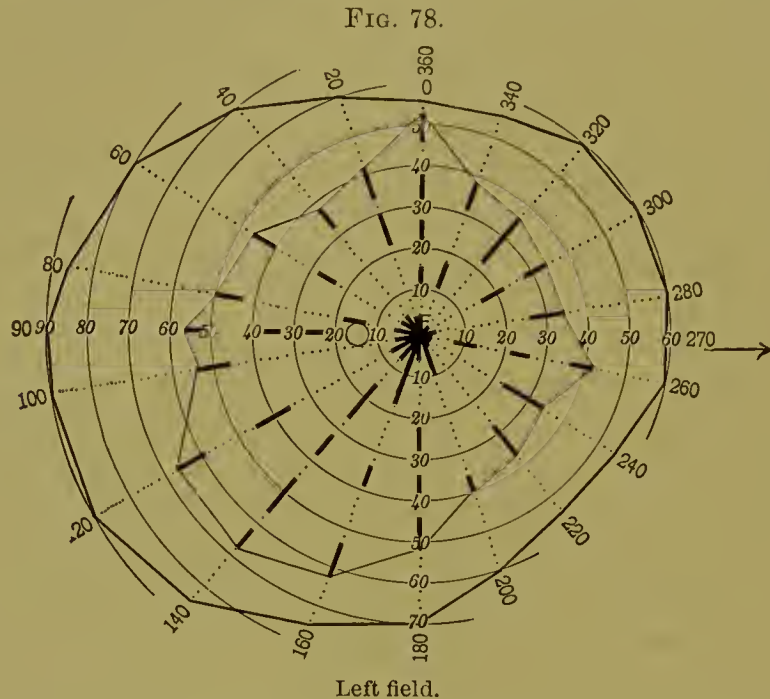
In certain grades of concentric shrinkage of the field caused by purely functional nervous trouble, it will generally be found that the limits of red vision reach to or even pass beyond those for blue vision. This fact is due to the remarkable phenomenon<sup>1</sup> that small blue objects seen during diminished illumination are more clearly recognized at the periphery than at the centre of the field.

Diminution of the field in purely functional nervous conditions is directly related to the degree of retardation of assimilation in the visual substance. This progress of concentric lessening can be demonstrated only when the exhaustion is systematically studied and central fixation is accurately maintained. The process of exhaustion generally becomes complete during examination with the perimeter. Occasionally cases are observed

---

<sup>1</sup> Landolt, Graefe und Saemisch, Handbuch der gesammten Augenheilkunde, iii. 535.

in which to a certain extent the exhaustion appears rhythmically, so that from point to point along the same meridian the examining object alternately appears and disappears. This condition the author has designated "oscillating field of vision." The heavy dashes (Fig. 78) mark the strips in which the examining object was perceived. In the intervening free spaces perception was wanting at the moment of the examination. The same oscillation existed when the examination was made with colors. Such an oscillating field of vision ordinarily shows a different form at each examination. Sometimes when the disappearing portions of perception in



the field of vision are studied in association with one another it will be found that to a certain extent they have a zonular form. It is very unusual to find a central exhaustion scotoma.

The oscillating field of vision is obtained only in such patients as complain of extraordinarily intense photopsias. It is usually a passing phenomenon during the condition of too ready exhaustion. Many nervous subjects when entering a dark room perceive bright and colored appearances similar to those of the kaleidoscope in the field of vision.

#### THE SIMULATION OF DEFECTS IN THE FIELD OF VISION.

As a rule, malingerers know nothing about central scotomata, ring-shaped scotomata, or hemianopic defects of the visual field. These conditions are simulated with great difficulty, and only when the subject is well up in the special knowledge of these conditions. The simulation, therefore, usually takes the form of a mere concentric contraction, either in a case in which the objective conditions are normal or in one in which some disturbances are present. In both cases, the simulator, as a rule, is not satisfied with the pretence of concentric diminution of slight degree.



If there is a well-grounded suspicion of malingering, the confidence of the examinee must be preserved in order that he can carry his deceit through successfully. His first statements are valuable, as changes in later statements become apparent the more he becomes confused by the different methods employed.

The examiner must keep the examinee under observation, and dictate the limits of the field areas to an assistant as they are found. The simulator must be examined on separate days with the same objects and by similar methods, so that the several results may be compared.

One of the simplest and most important means of proving the truth of the subject's statements consists in estimating the size of the field at different distances from the eye, thus permitting a comparison of the several values found. For this purpose the string apparatus introduced by the writer can be employed. To the middle of the upper margin of the perimeter (the point for fixation, *f*, in Fig. 4) is to be fastened a black linen thread three times as long as the radius of the perimeter, and on this thread is to be hung a white ball having a diameter of fifteen millimetres. This ball is placed at the end of a long black iron rod. By this means the ball can be carried in all directions of the field of vision at similar distances, as, for example, from the point *f* shown in Fig. 4. If the circle of the perimeter is placed in the vertical meridian, the examinee made to fix his eye, and the white ball placed at the full extent of the thread and carried from the periphery towards the fixation-point in the horizontal meridian, the ball will be arrested when it reaches the spot where the patient observes it. The circle of the perimeter is then to be brought to the ball and the corresponding parallel circle read off. In this way the greater portion of the field of vision can be determined. Care must be taken to have the circle of the perimeter perpendicular to the axis of the meridian that is examined, so that the simulator may have no point by which he can mentally measure the position of the object in space. It is necessary that the perimeter be so placed that a black wall in the shape of a half-cylinder shall surround the test-object so that the simulator cannot by indirect vision see anything but the perimeter upon a black surface.

The size of the field is first measured; after a calculated period of time for recuperation, the field is retaken with an ordinary five-millimetre-square white object. Generally the simulator is found to possess a much larger field when examined by the thread apparatus than when he is examined by the ordinary method.

The plan recommended by Schmidt-Rimpler<sup>1</sup> is more cumbersome. The examining object is made fast at the utmost limit of its recognition, and a prism of thirty degrees is placed before the eye. The patient is made to open the other eye and fix with it as well. The base of the prism is held in such a manner that the picture of the examining object falls on the part which is said to be blind. As the fixation-point is seen double, the simu-

---

<sup>1</sup> Deutsche Medicinische Wochenschrift, 1892, 24.

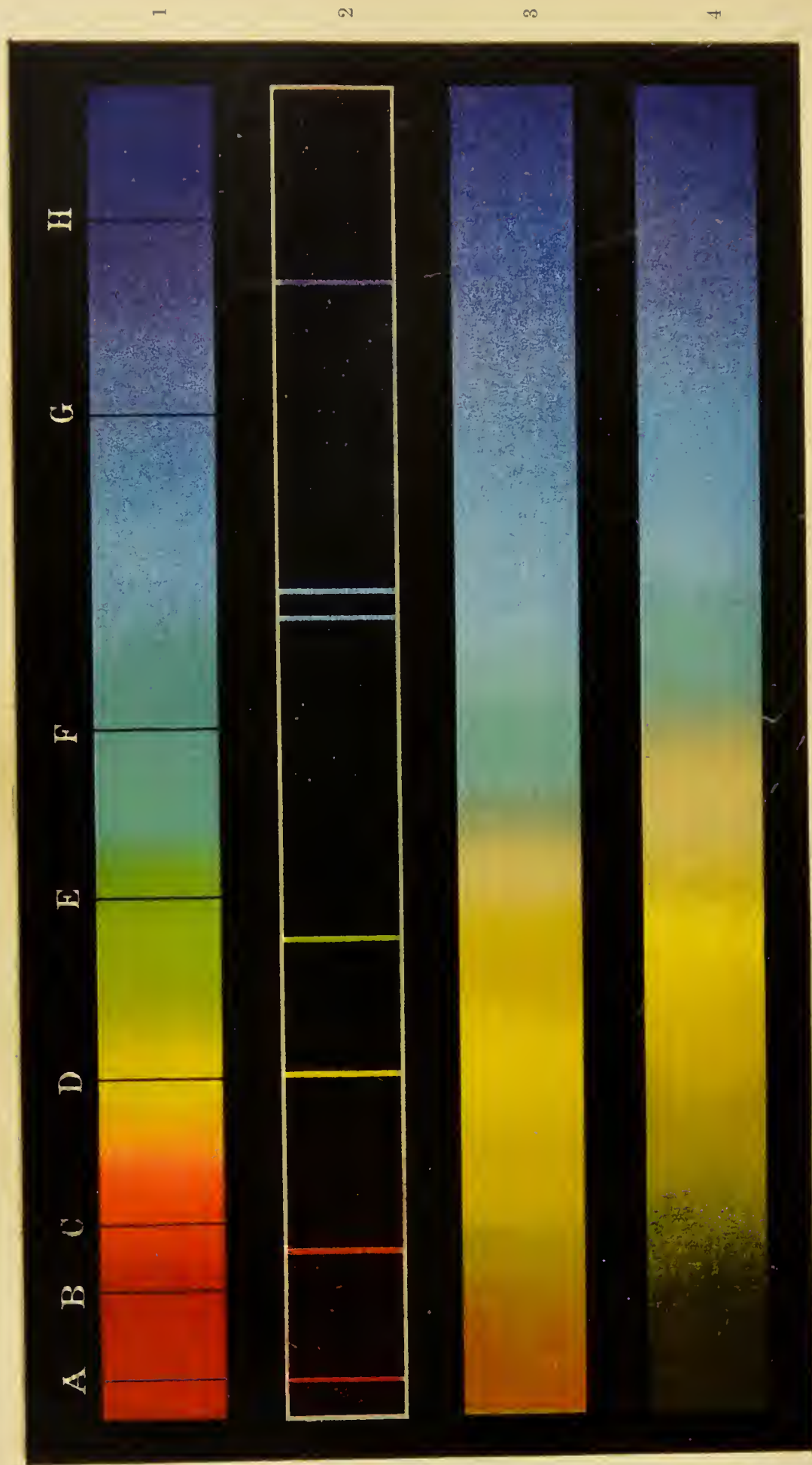
lator is tempted to give a correct answer as to the examining object at the periphery also. The presence of an object in the periphery surrounded by colors is proof of the fraud.

Uneducated simulators at times state that the examining object cannot be perceived at the fixation-point, whilst it can be recognized in other meridians. This they do even when no other symptoms of exhaustion can be determined. The relation of the orientation to the size of the defect found in the field is important. If there is a narrow field of vision, and the patient can move about without hinderance, it is probable that there is no organic lesion present. Proof of simulation can be obtained from the relation of the size of the visual field to central acuteness of vision. Often so high a degree of loss of visual acuteness is simulated that in reading only separate letters of the larger prints are said to be recognized. If this be so, the least trouble found when the case is examined with a perimeter will be a central color-scotoma. The simulator, knowing nothing about the existence of such a condition, will almost without exception not complain of such a symptom, and thus will be detected.

When color-limits are studied with the perimeter, the boundaries for color of the least light intensity should be taken first, beginning with green, then red, and lastly blue. During the examination the simulator should not be asked to state when he recognizes the color of the examining object, but should always be requested to state when he recognizes the surface.

In regard to the trustworthiness of the statements of the patients, conclusions may be drawn from the gradual loss of the impression of color towards the periphery and the assertions as to change in the tone of the color of the examining object. Usually the patients state that the colors suddenly appear and disappear.





1. The solar spectrum with Fraunhofer's lines from A to H as it appears to the normal eye. 2. The spectra of potassium (the first red and the last dark-blue line), lithium (the second red line), sodium (the yellow line), thallium (the green line), and cesium (the two light-blue lines). 3. The solar spectrum of the green-blind person. 4. The solar spectrum of the red-blind person.

# DETECTION OF COLOR-BLINDNESS.

BY WILLIAM THOMSON, M.D.,

Professor of Ophthalmology in the Jefferson Medical College; Attending Surgeon, Wills Eye Hospital, Philadelphia, Pennsylvania, U.S.A.,

ASSISTED BY

CARL WEILAND, M.D.,

Chief Clinical Assistant, Eye Department, Jefferson Medical College Hospital, Philadelphia, Pennsylvania, U.S.A.

---

CONGENITAL color-blindness, or the congenital defect in some eyes of confounding certain pronounced colors, has probably existed as long as the human race. But the first recorded case, so far as known to the authors, dates back only about one hundred and twenty years. This is reported by Huddar in the sixty-seventh volume of the *Philosophical Transactions* of 1777, and is that of a shoemaker named Harris, a very intelligent man, who could not distinguish certain colors, and who could not find the cherries on the tree because they appeared to him of the same color as the leaves. This case is referred to by the Abbé Rozier in the thirteenth volume of his journal, in 1779, with the remark that the anomaly in question was not so rare, as was shown by the case of the painter Calarean, who painted in his own portrait red close to green without observing it. Rozier must have had a clear view on the subject, for he states that there are people to whom nature appears dichromic, and also people to whom the colors seem to be nothing but shades or "degradations" of white or gray. The next best known case in the last century is that of the English chemist Dalton, who was red-blind and probably the first to study his color-sense by the spectrum. He found that the color-series from red to green appeared to him monochromatic and like yellow, whilst the other half appeared blue. While Dalton was thus successful in studying his color-perception, he was less so in looking for the cause of his anomaly. He thought it was not only probable but almost beyond doubt that one of the media of his eye was colored, most likely the vitreous, so that the green and red rays of light were absorbed there before reaching the retina,—an idea which even John Herschel could not argue him out of. Dalton insisted upon it, and directed that after his death his eyes should be examined. This was done by his physician, Ransome, who found the vitreous of a pale yellow color and when held before the eye without influence upon the color of red or green objects.

The first who entered into a systematic study of this subject was Seebeck. He not only collected all the former observations, but examined many persons himself with the view of determining the frequency of this anomaly.<sup>1</sup> He used colored papers and glasses, sometimes even prismatic diffraction colors, and mentions colored worsteds, rejecting silk, however, on account of its lustre. He clearly points out that no scientific value can be placed on the naming of the color, but that the method of matching has to be employed. He knows red-blindness and green-blindness and the factor of heredity, but blue-blindness is unknown to him. Though Seebeck covered almost the whole ground as far as the theoretical side of the subject was concerned, still the practical side remained untouched. This was done first by George Wilson (1818–1859), who published his main researches in 1853–55 in different papers read before the Royal Scottish Society of Arts, and in 1855 in book form under the title “On Railway and Ship Signals in Relation to Color-Blindness.” He examined over a thousand persons, recognized *total* color-blindness, *red*-blindness, and *green*-blindness, and first proposed to make the position of a certain class of railroad employees dependent upon the possession of a normal color-sense. He also employed worsteds for the examination, and, to shorten the latter, proposed to let the person pick out only the red and green colors.

Wilson’s work did not receive the attention it deserved, probably mainly because at that time the ophthalmoscope was occupying the minds of ophthalmologists and left no space for a subject in which that wonderful instrument could be of no avail. Indeed, it seems that Wilson’s researches were almost entirely forgotten for twenty years, when Favre in France (1873) and later Blasehko and Stilling in Germany and Cohen in Holland took up the subject anew.

But the main impetus to the practical side of this question was given by Holmgren, who in 1877 published his work on “Color-Blindness and its Relation to Railroads and the Marine.” In this he described, without any knowledge of Wilson’s work, the dangers of color-blindness, and proposed a method of testing with skeins of wool, which is still most used, under the name of Holmgren’s test, and will be given later. In the same year Donders in Holland published his papers on the quantitative examination of the color-sense,<sup>2</sup> and two years later Dr. B. Joy Jeffries, of Boston, followed with his well-known work “Color-Blindness: its Dangers and its Detection” (Boston, 2d ed., 1884), which has done a great deal to impress upon the American people the importance of the subject. At about the same time (1879) the writer of this article called the attention of the officers of the Pennsylvania Railroad to the researches of Holmgren, with the happy result that in 1880 a new system of testing for color-blindness, vision, and hearing was introduced, which will be described later. At the

---

<sup>1</sup> Poggendorf’s Annalen, Bd. xlii., 1837.

<sup>2</sup> Graefe’s Archiv, Bd. xxiii. 4, 1877.

International Medical Congress held at London in 1881 an international committee, of which Donders was the president and upon which the writer had the honor of being placed as the American representative, drew up important recommendations for the examination of the eyesight of mariners and railway servants. They emphasized the necessity for a standard of acuteness of vision as well as proof of color-sense. In November, 1880, the Council of the Ophthalmological Society of the United Kingdom had appointed a committee to consider defects of sight in relation to public safety, but only the question of color-blindness was dealt with in this body, with the result that among eighteen thousand and eighty-eight persons at different periods of life and in various social positions 4.76 per cent. of males and 0.4 per cent. of females were found to be color-blind to some extent. Though in England the question has been frequently discussed since that time, in medical journals as well as in commercial papers, still up to the present time there have been no government regulations issued in that country with regard to it. But to this subject we must return subsequently. At present we shall close our historical remarks and turn to the existing condition of the question.

It is easy enough to define congenital color-blindness as that defect of an eye through which it is unable to distinguish between certain colors while in other respects the eye is normal, but the greatest difficulty at once arises when we undertake to classify the different kinds. For the different views on the subject of color-perception, especially the theory of Helmholtz and that of Hering, have changed not only the nomenclature but even the symptomatology, so that, as Geissler<sup>1</sup> remarks, it would be almost necessary for the unbiassed student to treat of the subject side by side in two different ways, first in the sense of Helmholtz, and then in the sense of Hering. We shall try in this article to refrain as much as possible from theories and hypotheses, which had to be given to some extent in the article on Normal Color-Perception, and endeavor to keep mainly to the facts.

The principal types of color-blindness are usually described under the headings of *total* and *partial* color-blindness. These will now be described, and then a few words added about *reduced color-sense*; but it must be remembered that we treat only of the congenital form at present, while the acquired form will be referred to later.

*Total Color-Blindness, or Achromatopsia.*—Little difference exists between the authors of the different schools in the description of the manner in which the colored world appears to individuals of this class. The whole spectrum appears to them in different shades of gray, with the maximum of brightness in the yellow or the green. A totally color-blind teacher, whose case Magnus<sup>2</sup> reports, compared the spectrum to a delicately executed lead-pencil drawing which from the sodium line became gradually darker towards

---

<sup>1</sup> Die Farbenblindheit, Leipzig, 1882, p. 40.

<sup>2</sup> Centralblatt für Prakt. Augenheilk., Bd. iv. S. 373, 1880.

both unshortened ends. Any photographic print of flowers or colored objects will indicate the appearance, but with this difference, that here the blue parts appear the brightest. This, according to Hering, would mean that all the chromatic substances had disappeared, only the white-black one remaining. With regard to the Young-Helmholtz theory, Foster thinks that such cases, well authenticated, would be almost fatal to it; but, as already mentioned in the article on Color-Perception, it is even easier to comprehend these cases by this theory on the assumption that all the three photo-chemical substances have become alike, as is amply justified by the color-vision of the extreme periphery of our retina. Further, such cases as that mentioned in the report of the Committee on Color-Vision,<sup>1</sup> in which the principal sensation was green, and another in which it was blue-violet, can then be easily explained by assuming that all color-sensitive terminals are provided with a substance very similar to the green- or the blue-sensitive material of the normal eye.<sup>2</sup> We might therefore be tempted to add a class of *monochromatics* to that of achromatics; but, as all these cases are very rare, and therefore not of much practical importance, we shall pass to the second class, the *partially color-blind*.

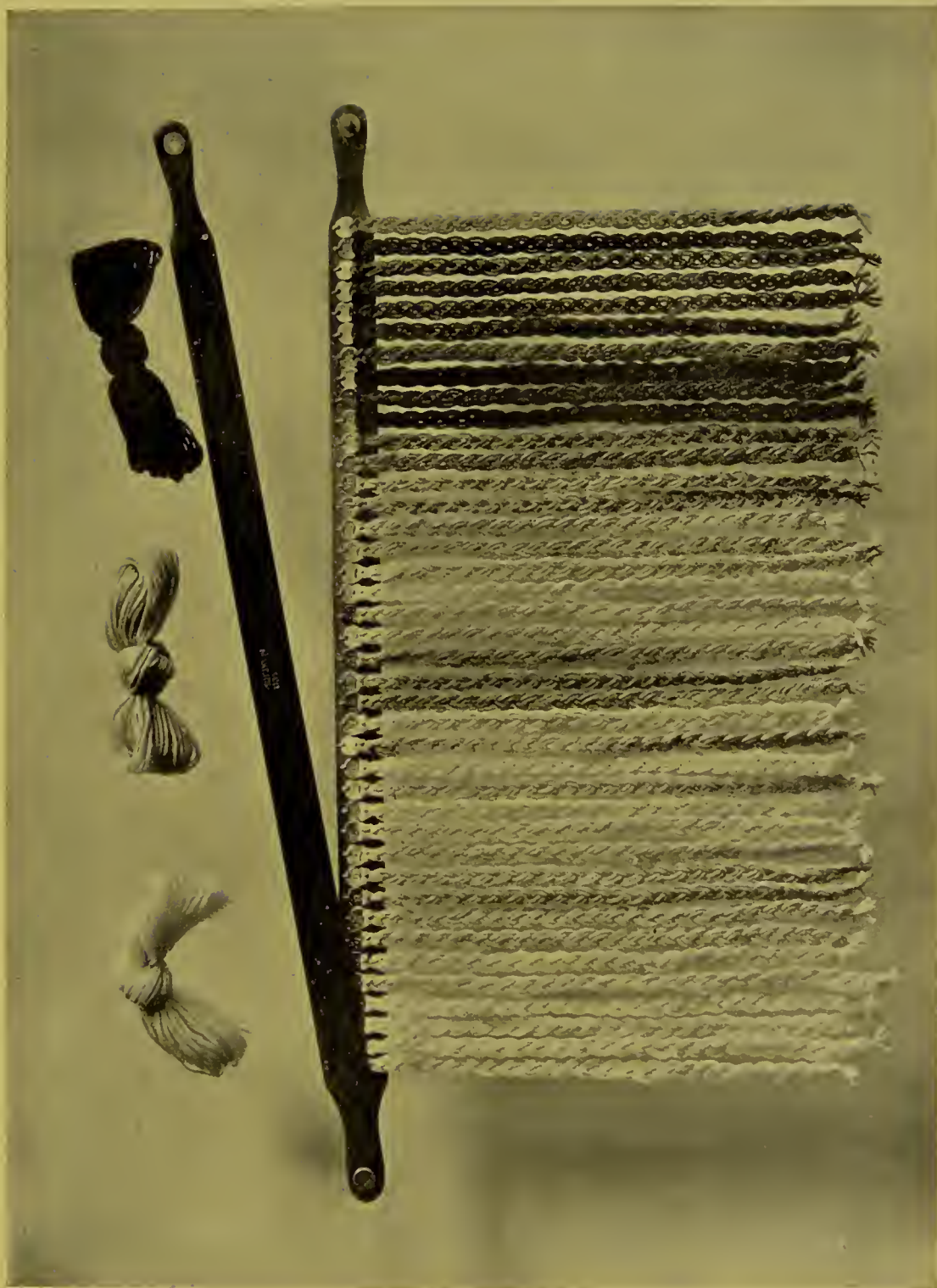
All typical cases of *partial color-blindness* are characterized by the spectrum appearing to them dichromatic and by the presence in it of a *neutral band*,—i.e., of a spectral region that looks to them white or gray. According to Helmholtz's theory, which is followed by Holmgren, three classes are distinguished,—blue-blindness, green-blindness, and red-blindness.

*Blue-blindness*, also called *violet-blindness*, *akyanopsia*, *axanthopsia*, according to the Young-Helmholtz theory is due to the blue-sensitive substance having become equal to the green-sensitive, or sometimes, perhaps, to the red-sensitive substance, so that the blue-blind person sees only red and green. Holmgren had such a case of unocular blue-blindness, where the red half of the spectrum was separated from the green part by a neutral colorless zone in the yellow. This yellow appears to such persons gray, because yellow, like gray, excites all the cones of their retina. Hering calls this condition *yellow-blue-blindness*, which according to his hypothesis is due to the absence of the yellow-blue substance in the retina. Usually the spectrum is considerably shortened at the blue end, which was also found to be so in the case of this kind examined by the Committee on Color-Vision above mentioned. In a typical case of this class we find, besides the symptoms just given, that *blue* is usually confounded with *green*, *purple* with *red*, *orange* with *yellow*, and *violet* with *yellow-green* or *gray*, which can easily be explained by the Helmholtz theory.

<sup>1</sup> Proceedings of the Royal Society, vol. li., No. 311, p. 287, July, 1892.

<sup>2</sup> One might compare the usual sensitive plate of the photographer with the retina of that patient of Abney's who perceived only the blue-violet well, because that plate also is most sensitive to that color; and the phototype of the author's color-stick for the detection of color-blindness, shown in the accompanying illustration, will serve to show how the different colors would appear to such a person.



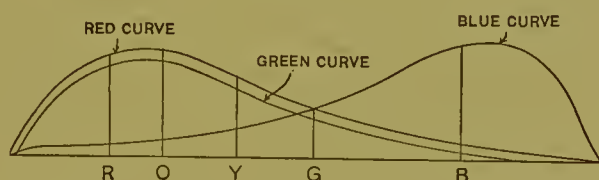


Dr. Thomson's color-stick.



*Green-blindness, achloropsia, aglaukopsia*, or, according to Hering, *red-green-blindness* with the spectrum not shortened, is of greater practical importance than the foregoing types. A person with this defect confounds light green with dark red; he does not recognize a dark-green letter on black, but recognizes well a red one on the same background. The spectrum is not shortened at either end, and contains only two colors for him, separated by a more or less marked neutral band, as the colored plate shows. What name these persons give the colors to the left of the neutral zone, the "*warm colors*" of Donders, whether they call them red, green, or yellow, is not of much significance, and depends upon circumstances, especially the degree of brightness, but usually the name yellow is preferred. The very interesting case recorded by von Hippel of *uniocular green-blindness* without shortening of the spectrum could name all the colors of the spectrum when he saw it in its entire length; but when single colors alone were shown, while the rest were covered, he called all colors from the extreme red to the bluish green yellow, and from there everything blue. *The single colors were perceived only as different shades of yellow or of blue.* The green-blind recognizes blue, and sees a certain green like red and gray, so that if he is given purple to match he will match it with bluish green or gray. The reason of this is that purple excites two color-sensations, red and blue, or in his eyes all the sensations which make up gray; but as green, according to the modified Young-Helmholtz theory, affects this patient in the same way as a weak red, it is clear that a bluish green must appear to him like blue plus red, and therefore equal to purple or gray. The accompanying diagram will make this still clearer. Here the red and the green curve may

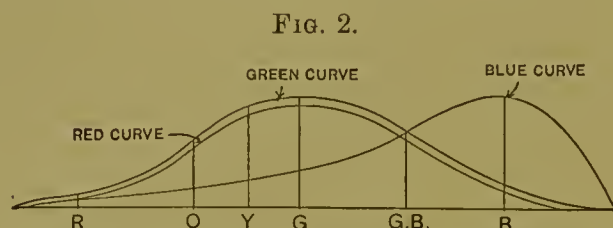
FIG. 1.



indicate by their neighboring position that the green-sensitive substance in the retina has become equal to the red-sensitive material. It is evident from the figure that at *G*, where in normal eyes green would be perceived, all the substances are equally stimulated, just as gray would stimulate them; but it is also clear that the purple of normal eyes would find its position here, as it stimulates the red and the blue sensation equally. We have therefore at this point the equation: Green = Gray = Purple. Some of the most frequent confusions, according to Preyer, are the following: brown with dark green, red with green, red with orange, red with yellow, red-yellow with green-yellow, bluish green with purple.

*Red-blindness, anerythroptia*, or, according to Hering, *red-green-blindness* with shortened spectrum, is characterized by the fact that three important points—the beginning of the spectrum, the band of greatest brightness,

and the neutral zone between the yellow and the blue—are transferred farther towards the blue. The red-blind person confounds the light-red colors with dark green, and he cannot see a dark-red square on a black ground. His spectrum consists also of yellow and blue, but his yellow does not begin, as in the former class, in the red, but only in the orange. This, according to the Young-Helmholtz theory, would mean that the red-sensitive substance has become equal to the green-sensitive, so that bluish green excites all the terminals of his retina, producing the sensation of gray. The accompanying diagram shows this at a glance. Here again the red and the green



curve indicate by their position that the red-sensitive has become equal to the green-sensitive substance. The point where the two substances are equally stimulated is at *GB*, therefore farther towards the blue than in the case of green-blindness. Here is situated the neutral line, indicating that to this patient a bluish green must appear as gray. Red at *R* stimulates very slightly, so that the purple of the normal eye must look to the patient like blue. It will be interesting in this connection to hear from Dr. Pole, who is red-blind, and who describes his case very carefully in a long article in the *Philosophical Transactions*, vol. cxlix., 1859, from which we give the following extract: "It is only after long and careful investigation that I have come to the conclusion that my sensations of color are limited to blue and yellow. But before I found this out—that is, for nearly thirty years of my life—I firmly believed that what I now know to be only differences in tone of one or other of these were different colors, and hence I was in the habit of talking of red, crimson, scarlet, green, brown, purple, pink, orange, etc., not, of course, with the confidence of normal eyes, but still with a full belief that I saw them. If, therefore, at that time any scientific man had examined me, I should have given him a description of my case which I now, after more careful study, know would have been entirely wrong. I should have told him, among other incorrect statements, that I saw red objects of a full tone, such as vermilion, a soldier's coat, etc., perfectly well, and I could, if necessary, have supported my assertion by naming correctly a great variety of bodies having this color, which indeed I am in the habit of doing every day." Purple to such a patient appears like blue, because he cannot see the red in it. From Preyer<sup>1</sup> we will give now the most frequent confusion-colors for the red-blind: red with dark green, yellow with green, green with bright red, bluish green with gray, orange with greenish yellow or with red, orange with golden yellow, with grass green, or with red,

<sup>1</sup> Arch. für Physiol., Bd. i. 4, 5, S. 299, 1868.

purple with blue. Very interesting also are the two tables given by Pflüger in the *Archiv für Augenheilkunde*, Bd. xi. 1, S. 9, 1881, in which he shows by means of the revolving disk that the red-blind requires on the disk a much larger surface of black than does the green-blind to produce the sensation of the same gray, as is also demonstrated by the fact that the neutral gray of the red-blind appears to the normal eye darker than that of the green-blind.

*Reduced Color-Sense, Dyschromatopsia.*—By this term is meant that condition of an individual in which only quantitative disturbances of color-perception are present. Here no errors are committed if the colored objects are of sufficient size and in a very good light; but admixture of white, gray, and black changes the character of the main color much more quickly than for the normal eye. This is quite different from a color-blind eye, which has a very fine power of distinction for the colors that it can recognize. Holmgren calls incomplete color-blind those persons who cannot recognize the ground color in tones strongly mixed with white, but see in them principally gray or brown. We also find other persons who cannot well distinguish the violet rays from the blue, or who call violet gray or brown. But, as they recognize all the other spectral colors, we must put them in this class. As a strange peculiarity we must further mention that some persons who recognize all the spectral colors, even if they are carefully isolated, who see no neutral band in the spectrum and stand the test with the polariscope (*vide postea*), do not pass Holmgren's test No. 1. They seem to stand on the limit. Perhaps their defect is to be explained by the fact that the spectral colors are much purer, while those of the worsteds are frequently very mixed, and that they can recognize colors well if pure, but not if these colors contain many spectral colors, making it more difficult for the mind to pick out the dominant one. Here we must again call attention to the fact mentioned in the paper on Color-Perception, that, according to Helmholtz, persons with trichromatic vision do not always show the same color-perception. Even the two eyes of the same observer frequently show small differences as tested by his leukoscope. Helmholtz explains these differences by the assumption that in such abnormal trichromatics the green-sensitive substance has become not like, but somewhat similar to, the red-sensitive substance. We may add here that for complete color-perception the brain-cells are just as necessary as the photo-chemical substances. It might occur that these central elements do not perform their function well, because they are not developed and educated enough; just as we find is the case with the cerebral parts connected with the periphery of our retina, where the faculty of distinguishing colors and form can be developed by practice to some extent. We can understand now that there may be such a condition as *color-ignorance*, in which the peripheral and conducting parts are perfectly normal, but the central parts are not educated enough to react with the proper name for the peculiar sensation. That even this may be objectionable for certain employments is evident;

and how far this ignorance may go sometimes is shown by the following passage from the Report of the Committee on Color-Vision: "The possibility of the existence of real color-ignorance such as would lead to a non-recognition of the true color of a signal appeared to them [the committee] very doubtful until they had taken the evidence of Staff-Surgeon Preston, R.N., for it was hard to conceive of ignorance which would lead to confusion in naming a red, a green, and a white signal. His evidence, however, was conclusive of its existence at certain recruiting centres, and more especially in a certain class of recruits."<sup>1</sup>

With the examination of the color-sense, it must be remembered, we have made about the reverse experience of that for acuity of vision. Taking the least visual angle which among educated people has been found necessary for the recognition of objects, we find that this is far too large for the inhabitants of mountain villages or of prairies. There we find many "over-normal" eyes,—which of course is a misnomer,—whilst when we examine the color-sense at the same remote places where neither occupation nor dress educates the mind for color-perception, we find also many who, measured by the complex color-language of the educated, are subnormal. But here it must be remarked that *color-ignorance* can be cured by education, while *true congenital color-blindness* is incurable, so that a person who shows simple color-ignorance in an examination may be justly re-examined.

*Relation of Congenital Color-Blindness to Heredity and Sex.*—There can be no doubt that heredity and sex play an important part in the occurrence of color-blindness. *Total* color-blindness occurs almost entirely in the male sex, and frequently several brothers are affected with the same abnormality, as in the instance reported by De Wecker. Sometimes nystagmus and amblyopia are present, so that the eyes have often been regarded as abnormal in other respects. In *red-blindness* and *green-blindness* these relations have been studied best, and it was known for a long time that this anomaly usually passes from grandfather to grandson, while almost without exception the daughter of the color-blind father, and frequently even the son, remain free from the defect. Thus, Dr. Pliny Earle, in the *American Journal of the Medical Sciences* for April, 1845, communicates the case of his own family, in which during four generations there were derived from seventeen marriages thirty-two male descendants with eighteen color-blind and twenty-nine female descendants with two color-blind. The fourth generation was divided into nine families of twenty-one male members with nine color-blind and twenty-two female members with two color-blind. Once it occurred that neither father nor grandfather showed the anomaly, which, however, appeared in the great-grandson. Jeffries, in his book on Color-Blindness, p. 58, reports from Professor Horner, of Zurich, the case of an ancestor born in 1642 from whom seven generations de-

---

<sup>1</sup> Loc. cit., p. 300.

scended with fourteen color-blind male descendants. The transmission of the anomaly was such that no female offspring ever suffered from it, that with one exception the color-blind fathers had sons with normal color-vision, and finally that the color-blind male members had normally seeing mothers, but were always (except the one son) the grandsons of color-blind grandparents upon the maternal side. It seems, further, that the influence of heredity is gradually diminishing, as in the case reported by Mauthner.<sup>1</sup> The transference of the defect to female members of a family is rare, but Cunier<sup>2</sup> gives an observation which shows an heredity of the defect from the mother to the daughters in *five* generations, whilst the sons remained free; altogether twelve color-blind women, who could not distinguish cherry-red from blue. Five of these descended from one mother; the male members of the family, eight in number, were not color-blind. Interesting also is the fact that brothers show usually the same individual character of red-blindness or green-blindness.

The visual acuity with the color-blind of these types is usually very good, though of course errors of refraction occur. Nystagmus does not occur, and both eyes show usually the same kind of anomaly, if they are both color-blind; at least there is no case on record where the one eye was red-blind and the other green-blind.

Blue or yellow-blue blindness has thus far not been shown to be hereditary, but, as Geissler<sup>3</sup> remarks, "as this kind of anomaly is not found out so easily, and as, besides, only a few well-authenticated cases are known, the factor of heredity cannot be excluded." Uniocular blue-blindness was found three times by Holmgren. This anomaly also occurs exclusively among men.

Here the fact may be mentioned that Darwin, Preyer, Jeffries, and Thomson found among their color-blind cases some which showed a very defective power of distinguishing different tones, but this we must regard perhaps rather as an accident; at least we are not warranted as yet in assuming causal connection.

*Acquired Color-Blindness.*—There is one great difference between congenital and acquired color-blindness. In the congenital form the visual acuity or form-sense is almost always normal, while in the acquired form we can almost always find a loss of form-sense: so that it may be stated that a man who once had normal *color-sense* cannot lose it without sooner or later losing more or less of his *form-sense*. We shall see later that there are a few exceptions to this rule, but they seem all to depend on some trouble in the cerebral centres for color-perception. As in acquired color-blindness the loss of color-sense may be confined either to the central parts of the retina, as in central color-scotoma, or to peripheral parts of the visual field, it is clear that testing by colored worsteds, as in Holmgren's method,

<sup>1</sup> Vorträge aus dem Gesamtgebiet der Augenheilkunde, 4. Heft, 1879.

<sup>2</sup> Annales d'Oculistique, t. i. p. 417, 1838.

<sup>3</sup> Loc. cit., p. 88.

will not suffice, since the color of such large objects may still be recognized by certain healthy areas of the retina. Other tests have to be used, which will be mentioned hereafter. Acquired color-blindness is frequently found in diseases of the optic nerve. In typical cases of atrophy the following changes are observed with regard to color-perception. First the perception of green is disturbed, it appearing yellowish, later grayish, whilst all the other colors are well recognized; soon, however, the red also is seen grayish, so that in orange only the yellow and in purple only the blue is perceived. The green-blindness is therefore soon followed by red-blindness, and so it happens that red, green, and yellow are confounded. Violet is considered to be dark blue. Later yellow also is lost, and finally blue is perceived no longer as such. These changes occur first in the peripheral parts of the retina, so that the areas in which the respective colors should be recognized according to the table given in the article on Normal Color-Perception are more and more narrowed down, until the fovea centralis begins also to be involved, at first still recognizing the colors of large objects, but later losing even this power and seeing everything grayish. Central scotomata for colors may occur alone, as in various affections of the optic nerve, the chorioid, and the retina, but the most frequent form is that which occurs in tobacco amblyopia. Here is observed an oval area, involving more or less the fovea centralis and extending as far as the optic nerve, in which colors are not recognized. Such a patient could do the rough work of a laborer, but would be unable to follow the occupation of a clerk, as his reduced visual acuity would not allow him to see fine print. He could still recognize the colors of large objects, like skeins of wool, but would be unable to see the color of a distant signal, as the small image of that colored light would fall only on his color-blind area. Besides these chronic nervous diseases, acute infectious diseases, like typhoid and typhus fever, malaria, erysipelas, etc., may be followed by defects in color-perception, usually inducing these by attacking the optic nerve.

There are, however, a few cases on record in which the color-sense is suddenly disturbed while the visual acuity remains the same as before. Here belongs a case carefully studied by Steffan,<sup>1</sup>—that of a man sixty-two years old, who after an apoplectic attack suddenly lost the power of distinguishing colors, which, as a color-printer, he had formerly been able to do very well. His vision remained perfect otherwise, and his color-defect in both eyes was most pronounced for green. Four years later this status was the same, light-sense and fundus oculi remaining perfectly normal. Steffan justly remarks that this case is probably the first by which a separate centre for color-vision is established, and he explains this sudden loss of color-sense in both eyes by an apoplectic focus in the median line affecting the color-centres in each occipital lobe. This case, then, is one of *psychical color-blindness*, and falls into the same category as the case of

---

<sup>1</sup> Arch. für Ophthal., Bd. xxvii. 2, S. 11, 1881.



temporary general psychical blindness lately reported by Macewen and mentioned by Keen in his article on Brain Surgery in *Harper's Magazine* for August, 1893. Very important also are those cases in which after concussion of the brain the color-sense becomes affected either temporarily or permanently. Wilson, for example, mentions the case of a physician who, after a fall from his horse, was unable to distinguish the different color-shades of flowers, and to whom the stalk and the leaves of a rose-bush appeared of the same color as the rose. Other more or less temporary anomalies of color-vision, as in hysterical amblyopia or in hypnotism, seem also to depend on central disturbances, but will not be further considered, as they are of no practical importance.

*Statistics of Congenital Color-Blindness.*—We must accept the earlier statistics about defective color-vision with great reserve, as they were frequently obtained by inaccurate methods and with an unconscious tendency to error in the direction of excess. The following table gives the result of trustworthy observers, who worked with numbers large enough to exclude accidental circumstances.

Observer.	Examined, Males.	Color- Blind.	Per Cent.	Examined, Females.	Color- Blind.	Per Cent.
Holmgren <sup>1</sup> . . . . .	32,165	1,019	3.16			
Jeffries <sup>2</sup> . . . . .	19,183	802	4.12	14,764	11	0.073
Committee of the Ophthalmological Society of England <sup>2</sup> . . . . .	14,846	617	4.16	489	2	0.4
Fontenay in Denmark <sup>3</sup> . . . . .	4,000	155	3.8			
Dr. Adele Field in China <sup>4</sup> . . . . .	600	19	3.16	600	1	0.17
In two Japanese regiments <sup>2</sup> . . . . .	1,200	41	3.4			
Total . . . . .	71,994	2,653	3.69	15,853	14	0.088

This table points clearly to the prevalence of color-blindness among the male population, and also to its equal occurrence in different nationalities. Among ten thousand men there are about three hundred and sixty-nine who are more or less color-blind, while among ten thousand women only about nine are found to be defective in color-perception. With regard to the cause of the rare occurrence of color-blindness among the female sex, one might think of the early education of the female mind for color. But although this fact may account to some extent for its rarity, and certainly does for the absence of color-ignorance, it cannot be considered a sufficient cause, as we have too many examples of highly educated men, like Dr. E. Brodhun or Dr. Hochecker, who have given much attention to their color-perception and undoubtedly developed it to the highest degree possible for them, but who by no amount of color-education can be made to distinguish between

<sup>1</sup> Dr. F. H. Bickerton, in Report of the Committee, p. 319.

<sup>2</sup> Report of the Committee, p. 290.

<sup>3</sup> Geissler, *Die Farbenblindheit*, S. 97.

<sup>4</sup> *Medical and Surgical Reporter*, June 1, 1889, p. 651.

certain colors. It seems to be more probable that the highly developed color-sensitive retina and brain of women belong to the development of their sex, like the highly developed mammary gland. Slowly indeed this fine feminine color-sense has been developed for thousands of years by the needs, wants, and pleasures of the feminine life, but now they are endowed with this result of long development at birth by the very nature of their sex.

*Seat of Color-Blindness.*—As our complete nervous apparatus for the perception of color consists essentially of three parts,—the *retina* with the chromo-sensitive end-organs, the *conducting fibres*, and the *cerebral centres*, in the latter term including those of the higher and lower orders,—it is evident that the cause of color-blindness might lie in either of these three organs. The question now arises, Where must we locate the defect in the different forms of color-blindness? With regard to *congenital* color-blindness, there seems to be no doubt that the fault is in the photo-chemical substances in the retina, or that at any rate the defect lies in front of the chiasm, as there are undoubted cases of unocular color-blindness. *Reduced color-sense* must probably be also attributed to abnormal conditions of the photo-chemical substances, while *color-ignorance* of course has its cause in uneducated or undeveloped centres. With reference, however, to *acquired* color-blindness, we find that any or all of three factors may be at fault. A lesion in the retina, a defect of conducting power in the optic fibres, or a pathological change in the cerebral centres for color-vision may explain a special case. But it is a strange fact, according to Leber,<sup>1</sup> that in diseases of the retina color-blindness sets in only when the pathological process has gone on to secondary atrophy of the inner retinal layer (the layer of nerve-fibre) and of the papilla nervi optici. Stilling found the color-sense intact in chorio-retinitis, glaucoma, retinitis albuminurica and apoplectica, and hemorrhage into the macula lutea in chorioiditis. This fact, that retinal or chorio-retinal diseases produce reduced vision without color-blindness, whilst diseases of the optic nerve produce reduced sight with more or less color-blindness, seems to indicate that the photo-chemical substances have a greater power of resistance to pathological influences than the axis-cylinders, and that the former become much affected only when the latter begin to be diseased. It seems, then, that acquired color-blindness is more apt to be due to lesion of the optic nerve or of the cerebral centres. If due to lesion of the conducting fibres, it is plain that form-vision must be disturbed also, as is the case in atrophy of the optic nerve, etc. But if the lesion (contusion, blood-clots, tumor, etc.) is in the cerebral centres, especially of the occipital lobes, then with the color-sense the form-sense may or may not be affected, according as the morbid process extends to one or both centres, as Steffan's case above mentioned demonstrates.

*Dangers of Color-Blindness.*—We have already spoken of the mistakes

<sup>1</sup> Graefe und Sämisch, Bd. ii. S. 1037.

that color-blind people are apt to make ; but, as most color-blind men are either red-blind or green-blind, and as, further, white, red, and green are the colors of the signals used, we give here a little table, modified from the Report of the Committee, p. 291, which shows at a glance the most frequent mistakes with regard to these signals.

Color of Signal.	To a Red-Blind Person appears	To a Green-Blind Person appears
Red.	Green or yellow. <sup>1</sup>	Red or yellow.
Green : the dominant color of signal being equal to green of spectrum well to the red side of the neutral band.	Grayish green or grayish yellow.	Grayish red or grayish yellow.
Green : the dominant color of signal being equal to green of spectrum at the neutral band of the green-blind.	Whitish green or whitish yellow. <sup>2</sup>	Whitish.
Green : the dominant color of signal being equal to green of spectrum at the neutral band of the red-blind.	Whitish.	Whitish blue. <sup>3</sup>
Green : the dominant color of signal being equal to green of spectrum well to the blue side of the neutral band.	Whitish blue.	Grayish blue.
White.	White.	White.

From this table it is clear how dangerous to the travelling public a red-blind or green-blind man would be, as he might mistake a red signal for a green one, or a green signal for a white one, or *vice versa*. It is true that in a testing-room a color-blind might recognize the colors by their relative brightness and dilution with white, for which these color-blind have indeed a very fine power of distinction. For, as the table shows, the red and different green signals look different, for example, to a red-blind man, and this power of distinction by their relative luminosity has been confirmed by the Committee, and has been observed frequently by the writer, who found that men who could not pass Holmgren's test nevertheless differentiated more or less correctly the colors of the lanterns in the office if the light was not diminished at the same time by some means or other.

It might be supposed that if the colors of the signals could be rightly given in the testing-room they would be equally well recognized elsewhere. But it must not be forgotten that the atmospheric conditions of the testing-room are often very different from those existing outside. For the color-

<sup>1</sup> The table of the Committee says green, but it is clear from the former exposition that the red-blind may think the red green or yellow, according to circumstances.

<sup>2</sup> Here the table of the Committee gives a grayish blue, which is seemingly not correct, as the green of that position in the spectrum lies in the red-blind towards the red side of the neutral band, as their own colored table shows.

<sup>3</sup> Here the Committee's table gives a grayish red, which cannot be correct, as the green of that spectral position lies beyond the neutral band of the green-blind towards the blue.

blind depends in his judgment mostly on the brightness of the colors, which factor is frequently changed by a misty atmosphere or by dirt on the cloth or the glass, and under such conditions he may easily confound the white signal of safety with the green one of caution or even with the red one of danger, so that it must be evident that *any judgment of the color of a signal which depends upon its brightness would be fallacious*. In this connection it may be interesting to mention the case of a red-blind man who was accustomed to take his standard from a star and decide upon his signal lights by comparison.

*Change of the Colors of Signals.*—One might argue that the colors of signals should be changed, as a greenish color well towards the blue would make it easier for the color-blind to tell it from red; but even then mistakes would occur, especially in certain conditions of foggy weather, when the bluish-green light in its passage through the mists is deprived of the blue rays in greater proportion than of the green ones,<sup>1</sup> so that then the same mistakes would happen as with the light that was green from the start. Blue might still more easily overcome the difficulty of the color-blind; but that cannot be done for practical purposes. For a blue glass as commonly met with, which means one that transmits many red rays besides the blue ones, allows four per cent. of the naked light behind it to pass through it, while by a glass of fairly pure blue the luminosity would be reduced to about two per cent. This luminosity in foggy weather would be reduced to nothing, a great danger in our times of high speed by land and water, where it is necessary to recognize the color of the light a few thousand feet away. A *yellow* signal would be luminous enough, but under certain circumstances would appear too much like white. Hence no good substitute can be found for the green, which transmits from ten to twenty per cent. of the luminosity of the light behind it, whilst the red glass also allows about ten per cent. of the light behind it to pass through. *Red, green, and white*, then, seem to be the best signal colors for practical purposes, and cannot be replaced by others, where three signals must be used; so that as the colors cannot be adapted to the color-blind, these latter ought not to be admitted to positions where quick and accurate distinction between red, green, and white is an absolute necessity.<sup>2</sup>

*Accidents Due to Color-Blindness.*—Wilson was the first who laid stress upon the practical importance of the subject; but his warning was unheeded. Nobody believed that accidents could be due to color-blindness until it happened on the night of November 15, 1875, near Lagerlunda in Sweden, that two express-trains ran into each other, whereby many persons

<sup>1</sup> Report of the Committee, p. 305.

<sup>2</sup> It may be interesting in this connection to remark that Cohn (*Archiv für Augenkunde*, Bd. viii. 3 and 4; Bd. ix. 1, 1878) found that in electric light the color of the same object could be recognized from two to four times as far with red and from one and a half to two and a half times as far with green as was the case in daylight, a fact that may perhaps be made practical use of in the near future.

were injured and one passenger and eight employees of the road were instantly killed. At the inquest facts were developed which led Holmgren to believe that this accident was caused by color-blindness. From that time Holmgren worked with indefatigable energy in this matter, and so successfully that since the beginning of 1877 only men with normal color-vision are employed in the railroad service of Sweden. But this is by no means so at present in all other countries. Even in Europe, where the government has more power in such matters than here, the regulations are as yet by no means perfect<sup>1</sup> and efficient, except in Holland, where the arrangements leave nothing to be desired. In Italy, where the railways belong to the state but are worked by private companies, there is no special law for the examination of railway servants as to their color-sense, but the employees are tested by Holmgren's method and as a means of control by Stilling's or Pflüger's tables. In France there are state and private railroads. There exists no uniform law about examination for color-sense, but Holmgren's wools are usually employed. In Germany, where nearly all the roads belong to the government, the examination for color-sense is prescribed by law, but the methods differ in the different states. In Austria, at least in the state railroads, the color-sense is looked into, and the examination is similar to Holmgren's. In England up to the present time there have been no government regulations issued to enforce an examination for color-blindness. Each company adopts or neglects precautions as it pleases, and the tests employed are generally inefficient. In the United States of America only three States, Ohio, Massachusetts (1881), and Alabama (1887), have passed laws; but they are satisfactorily carried out only in the State of Alabama. There are, indeed, in other States of this country, for example, in Pennsylvania, private companies that for their own satisfaction have instituted a color-examination, but the great majority of them seem still to think like a certain railroad company in Georgia, which, on an inquiry as to their examination for color-sense, reported in 1893, "The State laws of Georgia do not require the railroad companies to examine their employees as to color-blindness; hence we do not require it of them."

And yet there can be no doubt that every color-blind person who is employed on a ship or a railway must in certain positions be a source of danger to the public. To get a better idea of the danger to which the public is exposed in this respect, the reader must be reminded that in the year 1892 there were employed by the different railroad companies of the United States no fewer than 821,415 men, while the number of miles covered amounted to 171,563.52. Taking 3.69 as the percentage of color-blindness among men, we should get the enormous number of 30,310 color-blind men. Though of course not all of these have to do with the recognition of colored signals, and though many thousand miles have been protected by a test for

---

<sup>1</sup> Report of the Council of the British Medical Association on the Efficient Control of Railway Servants' Eyesight, March, 1892.

color-vision, nevertheless there must be still thousands of color-blind railroad employees who are a serious danger to the public. That many accidents have been caused by their mistakes seems very probable, though it must be admitted that it would be more difficult to ascribe them conclusively to defective color-vision than it was in the loss of the Isaac Bell, in 1875, reported in the Annual Report of the Supervising Inspector-General of Steamboats to the Secretary of the Treasury, Washington, 1880. It reads as follows: "On the night of the 5th of July, 1875, there was a collision near Norfolk, Virginia, between the steam-tug Lumberman and the steamship Isaac Bell, the former vessel bound to, and the latter from, Norfolk. The accident occurred about nine P.M. on an ordinary clear night, under circumstances which until recently seemed more or less mysterious. The master of the steamer and all his officers made oath that at the time signals were made to the tug the latter was from one to two points on the steamer's starboard bow, and consequently the steamer's green light only was visible to the approaching tug. Yet the master of the tug, whose statement was unsupported by any other testimony, asserted that the steamer's red light was exhibited, and signalled accordingly. The discrepancy in the statement was so great that many persons uncharitably charged the master of the tug with being intoxicated, although no evidence was offered in support of the charge. By this accident ten persons lost their lives. Upon a visual examination of this officer under the rules during the past summer, and during which time there had been no question as to sight by the Sergeant of the Marine Hospital at Norfolk, he was found to be color-blind, two examinations having been accorded him, with an interval of ten days between them." Two more cases are given in the evidence of Dr. T. H. Bickerton before the Committee on Color-Vision. There can be, then, no longer any doubt that the color-blind must be excluded from such positions, as their defect is incurable and the colors of the signals cannot be changed. The only question now is, How can they be quickly detected? What test shall be employed?

*Tests for Color-Blindness.*—More than forty different methods are in existence for testing color-vision, to describe which fully would be impossible in the space allotted to this article, so that only the most important ones will be mentioned here. First, however, it must be remarked that, no matter what test is employed, but *one* eye at a time should be examined, because even if only one eye is defective the person should be rejected, as from dust, foreign bodies on the cornea, or other causes in the normal eye he may be obliged to close it at the very moment when the recognition of the color is necessary.

*Naming of Colors.*—This test is a bad one, and by no means conclusive, as on the one hand the congenital color-blind may be able to name the colors used in the examination, having taught himself to give the usual names to the different shades, as was before mentioned, especially in the case of Pole, and as on the other hand many a normal-eyed person may not succeed in giving

the proper names to puzzling tints from sheer confusion or ignorance. This test, though still used,—for example, by the Board of Trade in London at least up to 1892,—is of no value for the detection of congenital color-blindness, though it is of use in acquired color-blindness, where the patient formerly had the full knowledge of colors, and where this method must be employed not only for direct vision, but also to obtain the field of vision for the different colors. As a test for *color-ignorance*, further, it is very good, especially if the puzzling shades are avoided. Such a test to exclude color-ignorance is necessary, especially in navigation, where it is often requisite that the lookout-man should without a moment's delay pass to the officer in charge the name of the color of a light; because hesitation, whether caused by real color-ignorance or by want of knowledge of the proper word (from being a foreigner), might involve serious disaster. Such color-ignorant people ought to be excluded until they have so perfected their education that they can name the important colors without hesitation.

*Matching of Colors.*—All the other tests to be named now depend upon the principle of matching a given color with another one to be selected from a greater number by the person examined. Here the naming is avoided, and the examiner can draw conclusions about the color-sense of the examinee by the colors taken to match the first. Most of these tests use colored pigments in reflected or transmitted light, some use spectral colors, and some the subjective colors of successive or simultaneous contrast.

*Wool Test of Holmgren.*—This method has been recommended by the Committee on Color-Vision as, in their opinion, the “simplest efficient test.” This test, or a modification of it, is certainly more used than any other. One important point, however, must be stated here. A color, as explained in the article on Color-Perception, has three constants, which together determine it unambiguously: 1, *hue*; 2, *purity, tint, or saturation*; and, 3, *brightness or shade*; and matching it exactly with another color would for a normal eye require this latter to have these three constants also the same. Now, the color-blind person mistakes the *hues*, but still looks for the same *purity* and *brightness* as in the test-skein. This would require, however, an immense number of wools, in order that the confounded hues should be present in the proper admixture with white and the corresponding brightness to be of perfect equality for the color-blind eye. Equality, therefore, being impossible, similarity only can be insisted upon. “As long, however, as there is only similarity, it is very difficult to agree whether the difference is one of hue, or of saturation or brightness.”<sup>1</sup> This must be conceded; but though a perfect *scientific* diagnosis cannot be obtained in that way, but by other methods to be given later, for practical purposes this method is perfectly sufficient, as it certainly shows that the color-blind person confounds colors in a way that would render his employment in certain occupations a danger to the public. Besides, this method is even more convincing, as it

<sup>1</sup> Helmholtz, loc. cit., p. 371.

is with pigment colors that he has to do in his signals. Holmgren frequently calls attention to the point that to get *resemblance* in color must be the main endeavor of the examinee, and that he must pick out all those wools that are somewhat lighter or darker, but of the same color, etc.

One other point must be mentioned here. There can be no doubt that the wools are apt to deteriorate with use, not only by the constant handling, but also to some extent by the light. They must, therefore, be renewed from time to time. But special care must be taken to have the test-skeins always of the proper character as to hue, purity, and brightness. The Committee recommends that sealed patterns of all three test-colors should be kept by some central authority, and that every set of test-wools should be officially passed as fulfilling the necessary conditions as to these three standard colors, and also as to the sufficiency and variety of confusion-colors. Captain Abney has referred the standard test-colors as approved by Holmgren to the spectrum, as follows: "The first standard is a light-green color, which can be matched with a green in the spectrum ( $\lambda = 566 \mu\mu$ ) when forty per cent. of white is added. The second standard skein is light purple or pink, and its complementary color is a green in the spectrum of  $\lambda = 510 \mu\mu$ . The color is diluted with about forty per cent. of white. The third test-skein has a color corresponding with a red of the spectrum ( $\lambda = 633 \mu\mu$ ) diluted with eighteen per cent. of white." Thus the three standard test-colors are fixed once for all, and can always be found again when by an accident the standard sealed pattern skeins shall have been lost. We will give now Holmgren's method of examination and diagnosis in his own words.

#### "METHODS OF EXAMINATION AND DIAGNOSIS.

"The Berlin wools are placed in a heap on a large table, covered by a white cloth, and in broad daylight. A skein of the test-color is taken from the pile and laid far enough away from the others not to be confounded with them during the examination. The person examined is requested to select other skeins from the pile nearly resembling it in color, and to place them by the side of the sample. At the outset it is necessary that he should thoroughly understand that he is required to search the heap for the skeins which make an impression on his chromatic sense, and quite independently of any name he may give the color similar to that made by the test-skein. The examiner should explain that resemblance in every respect is not necessary; that there are no two specimens exactly alike; that the only question is the resemblance of the color, and that, consequently, he must endeavor to find something similar in shade, something lighter and darker of the same color, etc. If the person examined cannot succeed in understanding this by a verbal explanation, resort must be had to action. The examiner should himself pick out the skeins, thereby showing in a practical manner what is meant by a shade, and then restore the whole to the pile, except the sample skein. As it would require too much time to examine every individual in this way, it is advisable, when examining large numbers, to instruct them



all at once, and to ask them to observe attentively the examination of those preceding them, so as to become more familiar themselves with the process. This saves time, and there is no loss of security, for no one with a defective chromatic sense will be able to find the correct skeins in the pile the more easily from having a moment before seen others looking for and arranging them. He will make the same characteristic mistakes; but the normal observer, on the other hand, will generally accomplish his task much better and more quickly after having seen how it has to be done.

“The well-known colored plate of Holmgren is for the purpose of assisting the examiner in the choice of his colors, and to help him to decide the character of the color-blindness from the mistakes made. The colors in the plates are of two characters :

“1. The colors for samples (test-colors); that is, those which the examiner presents to the persons examined; and,

“2. The ‘confusion-colors;’ that is to say, those which the color-blind will select as matches with the sample.

“The first are shown on the plate as horizontal bands, and are distinguished by Roman numerals; the second are shown as vertical bands, under the test-colors, and are distinguished by Arabic figures.

“The colored table is not intended to be used as a test; it is simply to assist the examiner in his choice of correct test-colors, and to help him to diagnose the special form of color-blindness.

“As to the similarity between the confusion-colors of the plate and the wools which the color-blind take from the heap, reliance must be placed simply on the hue, and not on their brightness or degree of color saturation. In all cases where we have to vary from this rule we must hold to the relative rather than the absolute saturation. The confusion-colors shown in the plate are only to illustrate the mistakes which the color-blind will make, and for this purpose they serve perfectly. Having made this explanation, we can pass directly to the test itself. The following are the directions for conducting it, and for making a diagnosis from the results :

“*Test I.*—The green test-skein is presented. This sample should be the palest shade (the lightest) of very pure green, which is neither a yellow-green nor a blue-green to the normal eye, but fairly intermediate between the two, or at least not verging upon yellowish green.

“*Rule.*—The examination must continue until the examinee has placed near the test-skein all the other skeins of the same color, or else, with these or separately, one or more skeins of the class of ‘confusion-colors’ (1–5), or until he has sufficiently proved by his manner that he can easily and unerringly distinguish the confusion of colors, or gives unmistakable proof of a difficulty in accomplishing it.

“*Diagnosis.*—An examinee who places with the test-skein ‘confusion-colors’ (1–5)—that is to say, finds that it resembles the ‘test-color’—is color-blind, whilst if he evinces a manifest disposition to do so, though he does not absolutely do so, he has a feeble chromatic sense.

“*Remark.*—We might have taken more than five colors for ‘confusion ;’ but we must remember that we are not taking into consideration every kind of defective color-sense, but only those which are important in connection with railways.

“As to No. 1, which represents a gray, we would remark that too much stress must not be laid on its luminosity, or any slight difference in its hue from the gray skeins which the examinee puts with the sample.

“If it is only required to determine whether a person is color-blind or not, no further test is necessary ; but if we want to know the kind and degree of his color-blindness, then we must proceed with the next test.

“*Test II.*—A purple skein is shown to the examinee. The color should be midway between the lightest and darkest. It will only approach that given in *II* of Plate II., as the color of the wool is much more brilliant and saturated, and bluer.

“*Rule.*—The trial must be continued until the examinee has placed all or the greater part of the skeins of the same shade near the sample, or else, simultaneously or separately, one or more skeins of the ‘confusion-colors’ (6–9). If he confuses the colors he will select either the light or deep shades of blue and violet, especially the deep (6 and 7), or the light or deep shades of one kind of green or gray inclining to blue (8 and 9).

“*Diagnosis.*—1. A person who is proven color-blind by the first test, and who in the second test selects only purple skeins, is incompletely color-blind.

“2. If in the second test he selects with the purples blue and violet, or one of them, he is completely red-blind.

“3. If in the second test he selects with purple only green and gray, or one of them, he is completely green-blind.

“*Remark.*—The red-blind never selects the colors taken by the green-blind, and *vice versa*. The green-blind will often place a violet or blue skein by the side of the green, but it will then only be the brightest of these colors. This does not affect the diagnosis.

“The fact that, in this test, many green-blind select, besides gray and green or one of these colors, also bright blue, has led to misunderstanding. Some have concluded from this that red- and green-blindness may exist together in the same individual ; others have thought that these two kinds of color-blindness are not readily distinguished by this method. The first conclusion is not correct. The two kinds of color-blindness have great similarity, but differ in innumerable slight variations. They are to be considered as two sharply defined classes.

“The second conclusion can arise only from not understanding and not using the method correctly. The especial purpose of this method must be kept constantly in view,—*viz.*, to find out the characteristics of the defects in color-perception of those examined. The characteristic of green-blindness is the confusion of purple with gray or green, or both. This confusion is the point to be determined ; everything else may be neglected. A

complete color-blind, who confuses purple with gray or green (bluish green), or with both, is *green-blind*, *do what else he may*. This is the rule; and the careful and observant examiner who understands the application of the test will at once distinguish it. It is, indeed, often possible, in marked cases of incomplete color-blindness, to decide to which class it belongs by the way the examinee acts with his hands. We do not mean by this that the diagnosis is always very easy. Practice and knowledge are necessary. As there is a long series of incomplete color-blindness between normal vision on the one hand and complete color-blindness on the other, there must naturally be a border-line where differences of the two kinds of color-blindness cease to be recognized.

“The examination may end with this test, and the diagnosis be considered as perfectly settled. It is not even necessary, practically, to decide whether the color-blindness is red or green. But to more thoroughly convince railway employees and others, who are not specialists, of the reality of the color-blindness, the examination may be completed by one or more tests. It is not necessary to the diagnosis, and serves only as a confirmation of it.

“*Test III.*—The red skein is presented to the examinee. It is necessary to have a vivid red color, like the red flag used as signals on railways. The color should be that of *I Ib* of the plate, rather towards yellowish red.

“*Rule.*—This test, which is applied to those completely color-blind, should be continued until the person examined has placed beside the test-skein all the skeins belonging to this hue or the greater part, or else one or more ‘confusion-colors’ (10 to 13). The red-blind chooses, besides the red, green and shades of brown, which (10 to 11) to the normal sense seem darker than red. On the other hand, the green-blind selects shades of these colors which appear lighter than red (12 to 13).

“*Remark.*—Every case of comparatively complete color-blindness does not always make the precise mistakes we have just mentioned. These exceptions are either instances of persons who are not quite completely color-blind, or of completely color-blind persons who have been practised in the colors of signals, and who endeavor not to be discovered. They usually confound at least green and brown; but even this does not always happen.

“*Monochromatic Vision.*—The absence of all except one color-sensation will be recognized by the confusion of every hue having the same intensity of light.

“Violet-blindness will be recognized by a genuine confusion of purple, red, and orange in the second test. The diagnosis should be made with discrimination. The first test often shows blue to be a ‘confusion-color.’ This may in certain cases be the sign of violet-blindness, but not always. We have not thought it advisable to recognize defects of this kind, and only the marked cases, that other tests establish as violet color-blindness, should be reckoned in the statistics.”

That Holmgren’s test, if carefully carried out, is a very efficient one

there can be no doubt. But that it takes some time will be admitted by all who have used it, and also that such testing requires, as the Committee<sup>1</sup> says, "careful training, and is not to be learnt except by practice; for it requires not only a registration of the absolute mistakes, but also a ready observation of the manner in which the candidate acts whilst under examination." In short, a medical man is needed, as is also demanded for this test by the Council of the British Medical Association mentioned above,—a medical man with special knowledge about the physics of light and the physiology and pathology of color-perception, who is not very frequent, and whose services for large bodies of men would be a heavy financial burden. These points were clearly brought to the mind of the writer when in 1880 the officers of the Pennsylvania Railroad invited him to give advice and assistance to them in their examination of the employees as to sight, color-sense, and hearing. Here the number of men to be examined was about forty thousand, scattered over more than five thousand miles of track, with about twelve thousand men actually dependent upon colored signals for their guidance, whilst the number of ophthalmic surgeons was limited, and not sufficient to make these examinations in any reasonable time. This idea was therefore given up, as well as the thought of training a sufficient number of the company's surgeons to perform this special task with fairness to the men and safety to the company. A system was needed that could be applied locally on each division, quietly, and at the convenience of the men without compelling them to lose much time. It had to be of so simple a nature that the facts could be collected by non-professional persons and could be so clearly presented to the division superintendent and to the surgical expert as to enable a perfectly correct decision to be made in every case. These and other considerations of weight led the writer to the invention of an instrument for the examination of the color-sense which could be efficiently used by any intelligent, instructed official, and a record of which could be permanently kept for the information of the officers, and as a guide for the action of any surgical expert whom the company might appoint to superintend the entire system. Holmgren's method of matching colored worsteds is adhered to, and the test-colors to be matched are green, rose, and red. Hence there is no departure from Holmgren's principle, the only novelty being to reduce the number of colors to those similar to the test-colors and to those usually chosen by the color-blind, and so to identify them as to enable an absent expert or superintendent to know precisely what colors had been selected to match the test-colors. The instrument was first described in the *Transactions of the American Ophthalmological Society* for 1880, and later in several other journals. The description of it as given by the writer at the sixteenth annual meeting of the American Ophthalmological Society is as follows. The instrument consists of two flat sticks about two feet in length and one inch in width, fastened by a

---

<sup>1</sup> Loc. cit., p. 302.

hinge at one end and connected by a button at the other. Between these, and concealed from view, are forty white buttons, having the figures from 1 to 40 clearly engraved on them, attached to the stick by small wire hooks, *which will permit of their easy removal or change of position.* To the eyes of these buttons are attached forty skeins of colored wool.

In obedience to Holmgren, the test-skeins are three: 1, light green, *A*; 2, rose or purple, *B*; and 3, red, *C*. These skeins are shown to the persons examined in turns, and they are directed to select from the stick the colors which will match them.

On the stick the colors are arranged alternately to match the tests, and to be of those confusion-tints which experience shows to be most commonly selected by the color-blind. The first twenty tints, set *a*, are therefore green and gray and tan-colored confusion-tints, and this part suffices for detecting any color-blindness.

From 21 to 30, set *b*, the tints are alternately rose and blue, and from 31 to 40, set *c*, the tints are red, and its confusion-colors brown or sage, etc. It is arranged, however, that the real tints commence with figure 1 and range onward by the odd figures, while the confusion-tints are designated by the even figures, so that when the entire examination is concluded—in a case of normal sight—only odd figures should appear recorded on the blank, whilst if a fault has been made by a color-blind person it will be revealed by the even numbers. In the green test the appearance on the blank of numbers beyond 20 would be more than suspicious, with the rose anything below 21 or above 30, and with the red any number below 31. It will be seen that any superintendent or supervising expert could thus be sure of the presence or absence of color-blindness by remembering the simple theory of the arrangement and scanning the blank on which the numbers of the tints selected had been recorded.

The first twenty tints are green and its confusion-tints, but the color-blind has the whole forty to choose from, and does frequently select reds at the end of the series, and thus proclaim his defect. Again, of these confusion-tints, five are gray and five are shades of brown, and we may thus guess at red- or green-blindness by the first mistakes of the color-blind,—the green-blind preferring the grays, and the red-blind selecting the browns. The positions of the skeins in each set can be readily changed at pleasure on the stick.

In the rose-test, between 21 and 30, the green-blind frequently select greens in the first series, and thus show their defect.

The examination for color-blindness by this instrument is conducted for the Pennsylvania Railroad Company by the agents of the division superintendents according to the following instructions:

Place the test-skein *A* at a distance of not less than three feet, and, without naming the color, direct the person examined to name the color, and to select from the first twenty tints, or set (*a*), of the yarns on the stick, ten tints of the same color as skein *A*, stating that they do not match, but

are different shades of the same color. Record the number of tints so selected. Do the same with skeins *B* and *C*, using for *B* the tints from 21 to 30, and for *C* the tints from 31 to 40. If the odd numbers are selected readily, the examination may be gone over very quickly.

When color-blindness is detected, any one of the even numbers or "confusion-colors" may be used as a test-skein, and the man may be directed to name the color and to select similar tints, when he will most probably choose odd numbers, which should be recorded, stating the number on the stick of the "confusion-color" used for a test, and then giving the numbers chosen to match it.

Then a soiled white flag should be shown, and the man be directed to name it, give its proper value as a signal, and select tints to match it, which should be recorded; next a green and finally a red flag are used likewise.

All the particulars are to be recorded as the examination proceeds, not leaving them to memory. Use the numbers in recording. Note whether the selection is prompt or hesitating by a distinct mark after the proper word on the blank form. When the deficient color-sense is discovered, and variations in the mode of testing are made by the examiner or examinee, they should be noted under remarks, or on a separate sheet to be referred to, if the blank has not room enough.

This plan has worked to the entire satisfaction of the company. An important feature of it is that it allows an intelligent layman to test the men, and so to sift out those that are suspicious according to the numbers on the blank. These reports are then sent to the surgical expert of the road, at whose request the color-defective person also would be ordered to report for a final professional examination. Thus on the road the laymen merely collect data, which do not decide the question, but lead to the examination by an expert; and the men are provided with a place for an appeal and a protection from all errors of the examination or mistakes of their own the result of trepidation or misunderstanding. This is a point highly valued by the men of the road themselves, as the following words show, written by Grand Chief Conductor C. S. Wheaton, of Cedar Rapids, Iowa, in 1887: "The Pennsylvania system permits of appeal, while that in Alabama does not. A greater latitude is allowed on part of the Pa. R. R.; they give an employee an opportunity to thoroughly test himself; while in Alabama they do not. I look upon the Pennsylvania system as the most fair to the employee, and still affording the company and its patrons the best possible protection." From records of the examination of the first two thousand men by non-professional but intelligent employees, it is evident that all color-blind persons must have been detected, since about 4.2 per cent. are clearly so defective from their separate reports. Later a smaller percentage was found,—among twenty-five thousand one hundred and fifty-eight men, only four hundred and eighty-one, or about 2 per cent.,—apparently because the men had begun to ask themselves about their color-

sense, and, when defective, left the service before detection, that they might obtain employment on other roads where no examinations were required. This also refers to the new men, who would not apply when they became aware of something wrong with their color-sense.

In 1887 the same system was adopted by the Philadelphia and Reading Railroad, with about fifteen thousand employes on two thousand two hundred miles of track, after a serious conflict between the officers and the men, which was settled to the satisfaction of both by the mediation of the writer. Among the first four thousand five hundred and fifty-three men examined there were 3.5 per cent. found to be color-blind. This test was also used in England by the Midland Railway, the London and South-western, and by many roads of this country, as has been shown lately by the writer in the *Medical News* for August 18, 1894, in an article "A New Wool Test for the Detection of Color-Blindness," from which we shall now cite. How many roads have adopted Thomson's color-stick is shown by the replies received in response to a circular recently sent to one hundred of the most important railroad corporations of this country, controlling 129,970 miles, asking if examinations were made as to color-blindness. Thus it was found that

	Miles.
Twenty-four using Dr. Thomson's test controlled . . . . .	38,786
Eleven using other methods controlled . . . . .	15,679
Thirty-one making no test controlled . . . . .	29,428
Thirty-four making no reply controlled . . . . .	46,077

The Pennsylvania Railroad system has accomplished much good, but there is yet more to be done to bring all the roads in the country under the protection of some efficient method of testing, to secure both the roads and the public against loss of life and property from these well-known defects of their employes. The total mileage of the country is 180,955, and there are nearly 1,000,000 employes.

Great progress has been made, since, at this time (1896) the total number of corporations which have adopted this system, and have used the "color-stick" and the new wool test for the detection of color-defects, is estimated at seventy-eight, having under control a total mileage of 106,395 miles,

The protection of over 100,000 miles of track by one system is an efficient answer to the charge from England, where the total trackage is but 19,288 miles, that nothing had been done in the United States beyond the passing of a law in the State of Alabama on this subject. It is also a great credit to the directors and officers of those roads, who have voluntarily brought about this reform without any pressure from legislation.

In order to show how the Pennsylvania Railroad Company keeps its records of these examinations, we submit the following fac-simile of an actual blank :

WEST JERSEY RAILROAD COMPANY.

CAMDEN, January 19, 1883.

Examination of sight and hearing of James A. Morris, aged twenty-two, employed as locomotive fireman, applicant for

ACUTENESS OF VISION.		RANGE OF VISION.		
The number of the series seen at twenty feet distant.		Least number of inches at which type D—0.5 in test-type pamphlet can be read.	Right eye, 4½ inches.	Left eye, 4½ inches.
Right eye.	20-30			
Left eye.	20-20	FIELD OF VISION.		
Good or defective . . . . .			Good.	

*Color-sense.*

Test-skein submitted.	Name given.	Numbers selected to match.
A—Green.	Green.	3, 26, 24, 7, 11, 22, 15, 5, 1, 17, 28, 9, 19, 30, 13.
B—Rose.	Red.	37, 33, 29, 12, 39, 31, 21, 35, 25, 27, 23.
C—Red.	Red.	37, 33, 31, 35, 23.

Second Color-Test.			Third Color-Test.		
Number shown.	Name given.	Numbers selected.	Flag shown.	Name and use given.	Numbers selected.
24	Green.	26, 22.	Soiled White.	Safety, White.	2, 4, 6.
39	Yellow red.	Could find no match.	Soiled Green.	Caution, Green.	36, 38.
30	Blue.	26.	Soiled Red.	Danger, Red.	37, 33, 31.

*Selection prompt or hesitating.*

Prompt.

*Hearing.*

Right Ear.		Left Ear.	
Watch.	Conversation.	Watch.	Conversation.
8 feet.	20 feet.	8 feet.	20 feet.

*Remarks.*

Escaping steam prevented watch-test.

J. J. BURLEIGH, *Examiner.*

Acuteness, right eye defective. Range, good. Field, good. Color-sense, defective. Hearing, see remarks.

JOS. CRAWFORD, *Superintendent.*

NOTE.—Those approved, marked "Appd."  
Those not approved, marked "Not Appd."



As the result of much experience, and after a recent study of the entire subject, I would suggest some improvements that will enable a new test to be used in connection with the color-stick or as a substitute for it. The color-skeins of this new arrangement have been most carefully selected, and a standard set will be kept, so that renewals may be made of the entire set or of those skeins that may become faded, soiled, or lost. The new set consists of a large green and a large rose test-skein, and forty small skeins, each marked with a bangle having a concealed number, extending from 1 to 40, placed in a double box, so arranged as to keep the two series apart and to permit each to be exposed upon a table in a confused mass. The stick is dispensed with, as giving too fixed an arrangement to the skeins and not enough *confusion*, although the skeins could be readily removed from their hooks and changed in position for this purpose.

The large green skein being placed near by, the small skeins from 1 to 20 are exposed in good daylight, and the employee under examination is directed to select ten shades of the same color as the test-skein. One with normal vision will choose promptly and with ease the ten greens with odd numbers on the bangles. A color-blind person will hesitate, and his selections will contain some even numbers, and the confusion-colors will be shades of brown, etc., containing some red, or shades of gray, and will indicate the color-defect. These figures are to be recorded on a blank, and the twenty skeins are to be removed. The large rose skein is then used, and the examination repeated in like manner with skeins numbered from 21 to 40, and the result recorded. The confusion-skeins, which have even numbers, are blue, green, and gray. From the selections made by the man found color-defective by the green-test, we are able to decide the character of his color-blindness. Those selecting blues are red-blind; those taking greens and grays are green-blind, according to the nomenclature of Holmgren. There are ten roses and ten confusion-colors in the second series.

The red test-skein of the stick, with its confusion-colors, is omitted entirely, and the test is made to conform more strictly with Holmgren's method, while the examiner is also provided with forty questions of decisive clearness. Greater scientific accuracy is obtained by this method, and with the careful selection of these confusion-colors I now regard this system as an improvement upon the stick, and as a safer and more simple method to be used by a non-professional examiner. The blank will also give to the division superintendent or to any supervising surgical expert a more simple report of the examination. The yarns are to be kept from the light in the double box, one side of which is colored green and the other rose, to aid the examiner in keeping the series separate and to save time. The test will be a valuable addition to those to be used by surgical experts. This test is known as the New Wool Test, and will be used by the Pennsylvania Railroad Company in conjunction with the color-stick test.

Doubtful cases are tested again by Holmgren's wools and other tests.

Another modification of Holmgren's test is Dr. Jeaffreson's test-disk, which is thus described by the Committee:<sup>1</sup>

"Dr. Jeaffreson's test-apparatus consists of a rotating celluloid disk, about a foot in diameter, upon which skeins of wools are arranged radially at the outer edge. All of the disk, except a small aperture, is covered. By means of a button attached to its centre, the disk can be turned until any color is brought opposite to that standard test-color which is seen in the upper aperture. The test-skeins are the three Holmgren test-colors, and a yellow, blue, and purple. The apparatus is mounted on a frame, so that it can be hung upon the wall.

"In using the test the usual course is to point out to the person under examination the pale-green wool in the upper aperture, and request him to turn the button until he brings several skeins of what appear to him to be the same color on the disk opposite to the one he has to match. When the examination with this color is completed, the pink skein is proceeded with in the same manner, and this is followed by the other test-colors, if considered necessary, following it, if desired, with from one to twenty confusion-colors. The colors on the disk which are chosen can be registered by numbers for future reference, or for comparison with the results of a second examination, where, in case of disputes, it is called for."

A new series of Berlin wools for an accurate detection of subnormal color-perception was brought forward by Dr. C. A. Oliver<sup>2</sup> in 1886. He objects to all fixed arrangements, and makes his set consist of three series of colors. First, five principal test-skeins, pure green, red, blue, yellow, and rose, all of equal intensity. Second, a series of twenty small pure match-skeins of either a pure tint or a pure shade of one of the larger skeins. Each skein has a small black metallic bangle, containing intaglio lettering, fastened to it, which indicates the tint or the shade of one of the principal tests. Third, a series of seventy-two small confusion match-skeins. This set may also be used by any educated layman, as each test-skein has its color-value expressed upon it. It is certainly a good test, on account of the careful choice of the colors and their scientific arrangement. At the meeting of the American Ophthalmological Society in 1893 Dr. Oliver simplified his method still more by dispensing with all but the five principal test-skeins, five pure match-skeins, and eighteen confusion-skeins of relative equal intensity to the pure match-skeins, so that he now employs only twenty-eight wools. The patient is asked to pick out the three nearest matches to each of the test-skeins.

The color-table by Dr. A. Daae, of Norway, is based upon the principle of Holmgren. It contains ten horizontal lines of seven little squares of colored wools each. Only in two lines (No. 8 and No. 10) are all the colors alike, being different shades of green and red. All the other lines

---

<sup>1</sup> Loc. cit., p. 392.

<sup>2</sup> Transactions of the American Ophthalmological Society, 1886.

contain different colors. If any of these other lines seem to consist of shades of the same color to any person, he is color-blind, the different lines indicating the different kinds of color-blindness. This table is very convenient; but in most cases a confirmatory examination by some other test will be required.

There are many other modifications of Holmgren's method, as the color-tables of Reuss, the embroidery patterns of Cohn, the colored cylinders of Badal, the yarn-covered spools of Schenke, and the rolls of pseudo-isochromatic wools of Donders; but we must pass them over and turn to the examination by colored pigments, which are much lauded by Cohn and Mauthner, the latter of whom remarks that one of his color-blind patients could distinguish red worsteds by the difference of their surface, whilst the same person with these pigments, enclosed as they are in little glass bottles, did not have the same clues, and so betrayed himself. Mauthner has thirty-three little bottles filled with different pigments, some with one pigment only, some with two pigments, *pseudo-isochromatic*, but so chosen that they appear of different colors to the normal but of the same color to the color-blind eye, and some vials finally with such pigments, *anisochromatic*, as must appear different to normal and to color-blind eyes. The examination is proceeded with in the same way as with the wools, but the bottles must always be held so that as little light as possible is reflected from the glass, since otherwise this light mingles with that from the pigments and disturbs the test.

Colored lanterns have also been used by Holmgren and others, one with red and one with green glasses. There are three shades of each color that can be turned around the flame. This method is not so conclusive as other tests, for reasons already given, but is useful to convince the color-blind or the officers of a railroad of the actual presence and danger of the defect. A similar lantern-test is used by Dr. Emmet Welsh, who in his present examination of the employees of the Grand Rapids and Indiana Railroad uses also Holmgren's test and the writer's color-stick, and thus far has found among six hundred and seventy men twenty-six color-blind, or 3.88 per cent.

Stilling has constructed chromo-lithographic tables which depend upon the fact that the color-blind are not able to distinguish two colors quite different to the normal observer if these lie on the same side of the neutral band in his dichromatic spectrum and have the same brightness. His Table 2, for example, consists of red letters on a brown ground, which cannot be deciphered by a red-blind person. They are, however, open to the objection that if the two colors do not happen to suit the patient's individual peculiarity the letters will be still recognized by him.

While the methods above mentioned allow only of the determination of the color-perception *qualitatively*, there are other tests by which the color-sense can be tested *quantitatively*. Of these we shall mention two or three. The first is that by Donders, first described in *Graefe's Archiv*,

xxiii. 4, p. 282, 1877. For *reflected* daylight he uses small circles of colored paper one, two, five, ten, and fifteen millimetres in diameter, which are glued to a small piece of black velvet. For railroad men he recommends the material used for the signal-flags. If the object which is recognized in its color by the normal eye at twenty metres is seen only at four metres, then the examinee should have a color-sense equal to  $\frac{4}{20}$ . Donders takes it as a general law that bright saturated colors one millimetre in diameter when placed on black velvet in a *good* light will be seen at five metres by an eye with normal color-acuity. Donders has also constructed an apparatus for examination by *transmitted* light, which allows the brightness of the light to be so varied that the one-millimetre opening covered by the colored glass will appear in the right color to the normal eye at five metres. The openings in the screen are also one, two, five, ten, fifteen, and twenty millimetres in diameter. If we now call  $m$  the diameter of the opening necessary to make the patient see the color at  $d$  metres, whilst the color of the one-millimetre opening is normally seen at  $D$  metres, then the patient's power of color-perception  $K$  is really  $K = \frac{1}{m^2} \frac{d^2}{D^2}$ , as the color-perception is in inverse ratio to the amount of light necessary for its recognition. The amount of light, however, is proportional to the square of the diameter of the colored opening, and inversely proportional to the square of the distance of the patient from the luminous opening. But, as Donders says, this  $K = \frac{1}{m^2} \frac{d^2}{D^2} = \left( \frac{1}{m} \frac{d}{D} \right)^2$  is not very convenient, "so that, as a rule, we may confine ourselves to the formula Color Vision, or C. V., equals  $\frac{1}{m} \frac{d}{D}$ , and, if we use the one-millimetre opening only, to the formula C. V. equals  $\frac{d}{D}$ ;" *i.e.*, the usual formula employed also to express the visual acuity. To give an example, let us suppose that the patient could recognize the color of the twenty-millimetre opening only when at one-fourth metre from it, while the examiner with normal color-sense could see the color of the *one*-millimetre opening at five metres, then the person's C. V. would equal  $\frac{1}{20} \times \frac{1}{5} = \frac{1}{400}$ . Should, however, the light behind the opening be so weak that the examiner himself sees the color of the *one*-millimetre opening only at three metres, while the patient recognizes the color only when the opening is twenty millimetres large and he is one-half metre from it, then the C. V. of the patient would be  $\frac{1}{20} \times \frac{1}{3} = \frac{1}{120}$ . In reality the color-vision is more reduced, it being only  $\frac{1}{160,000}$  in the first and  $\frac{1}{14,400}$  in the second case, as compared with that of the examiner. The examiner must not allow the patient to gaze steadily at the color longer than one or two seconds, as

otherwise the complementary color may be called up and thus the decision be rendered difficult.

Dr. Oliver has also constructed an instrument for measuring the color-sense.<sup>1</sup> This instrument consists of a perforated disk of blackened zinc in which there is inserted a movable graduated slide made of dead-black vulcanite, the disk being bolted to three circular cards upon which are known areas of color. By rotation of these color-bearing cards and movement of the slide, any definite amount of color-exposure may be made. By means of an ingenious scale upon the slide, the amount of exposed color-area (from one millimetre square to ninety millimetres square) can be seen at a glance. The color-cards have upon them adaptations for both reflected and transmitted light.

Lately Dr. Brudenell Carter has devised a new instrument for the quantitative determination of the color-sense. It must be used in a dark room, and consists of an oblong box which has in the front side a collimator lens that makes the rays of light from a lamp enclosed in a separate box fall parallel on the opposite side of the little dark chamber, where a slide moves behind a round hole in this back wall. This slide is so arranged that different pigment colors either on a white or a blackened background can be exposed to view; while the amount of light that falls on these colors is regulated by a changeable diaphragm, the opening of which can be made to vary from zero to one thousand square millimetres. There are also on the front side two sight-tubes, so that both examiner and patient may look at the same time. The physician first determines with what diaphragm he is just able to distinguish the different colors on the slide; then the patient does the same for his eyes. At the outside of the box there is an index that registers the side of the square diaphragm used, in millimetres. Suppose the examiner had to use under the existing conditions a square diaphragm of 2 millimetres' side and the patient one of 3.5 millimetres' side, then the color-sense of the patient as compared with that of the surgeon would be  $\frac{(2)^2}{(3.5)^2} = \frac{4}{12.25}$ , or a little less than  $\frac{1}{3}$ , as of course the color-sense, as stated before, is in inverse proportion to the amount of light necessary, and this quantity of light is directly proportional to the opening or the square of the side of the diaphragm used, the diaphragm retaining always the form of a square. While the instrument is thus used for reflected light, it can also be employed for transmitted light by using the colored glasses in the side and letting the patient look at them from the opposite side as before. Carter found in several cases of imperfect color-perception that while he could readily distinguish light-red and light-green dots with a diaphragm of four square millimetres, the patient had to use an opening of eighty square millimetres for the same thing. Of course the absolutely red-blind or green-blind could not see the colors, even in the fullest illumination possible,

<sup>1</sup> Transactions of the American Ophthalmological Society, 1885.

in the sense in which we see them : so that the three last-mentioned instruments are more useful for patients with *reduced color-sense*, but very good for an examination of the central color-sense.

The phenomenon of simultaneous contrast has been referred to in detail in the article on Normal Color-Perception. This contrast has been used for the detection of color-blindness in various ways by Cohn, Pflüger, and others. We shall mention here only the test of the colored shadows by Stilling, which depends upon the fact that the shadow of an object like a lead-pencil produced by colored glass in front of a light appears in the complementary color of the glass used if the shadow is illuminated by daylight. In day-time all that is needed is an ordinary lamp, in front of which is held a piece of colored glass with the one hand, whilst with the other one holds a lead-pencil in front of a sheet of white paper fastened to the wall. The shadow of the pencil at once appears upon the white paper in the contrast-color of the glass. The red-blind or green-blind, who mostly concern us, will declare the shadow to be simply dark if red or green glass is used ; at the best they may pronounce it blue with a red glass, as this also transmits yellow rays, whilst with the use of a green glass, which transmits not only yellow but also blue rays, they may consider the color of the shadow as blue or as yellow. If the examiner is in doubt about the statement of the candidate, it is best to make the patient match the color of the shadow by worsteds, or to make him point to the nearest color in a good color-table. Holmgren has constructed an apparatus, called a chromatioskiameter, which allows this examination to be made with greater convenience, and Cohn for the same purpose has devised his chromaskiopticon ; but, as Oliver remarks, it is a serious objection to the general employment of this method that " we are dealing here with subjective colors, which are so vague and dependent upon so many idiosyncrasies" that not everybody sees them well enough to make it a conclusive test. Here the author may be allowed to mention a very simple and quick method which he frequently employs in his office. It consists in making a patient look through a good cobalt glass at a light which to an eye accommodated for the distance of the light or a nearer point will appear red with a blue halo around it, whilst to an eye accommodated to a distance greater than that of the light it will appear blue with a red halo around it. The red-blind or green-blind will see the blue very well, but the red will betray him soon by its absence.

In Belgium an instrument like an optometer is used which allows at the one end a green, blue, red, or violet glass to be placed while the person being examined looks through a stenopæic opening into the instrument and matches the colors he sees by colored worsteds. This method, like that of Donders, will also demonstrate central color-scotomata.

For scientific examinations the *spectral colors* are used. A spectroscope is employed, and the patient is not only asked to name the colors of the spectrum *seriatim*, as of course he might have learnt them by heart, but also to match them with colored wools. The instrument must be so con-

structed that by a special device any color of the spectrum in variable width can be exposed alone, and that this spectral color is indicated by a scale. Hirschberg had a double spectroscope made for him which is fully described in the *Centralblatt für praktische Augenheilkunde*, Bd. iii. S. 55, 1879. The patient is here enabled to match a given spectral color with another immediately below it. It allows further of the superimposition of any two parts of the two spectra, to see, for example, whether two colors are complementary. These spectroscopic examinations are especially useful because they enable the examiner to determine exactly whether the spectrum at either end appears shortened or not, and also whether there exists a neutral band of gray in the spectrum, the presence of which alone would indicate color-blindness without further examination. This method, of course, cannot well be employed for the examination of large bodies of men, but perhaps ought to be more used for fine clinical work, as by it the colors are accurately fixed quantities and allow other investigators to verify the work under the same conditions. As the Committee says, "The test with the spectroscope requires an apparatus somewhat complicated in construction, and therefore expensive, but it should be applied when an appeal from the verdict of the examiner is made." Captain Abney<sup>1</sup> lately has constructed an apparatus which enables a patch of what is practically pure monochromatic light of any spectrum-color to be placed upon the screen at once, and an equally large patch of white light alongside of it by means of the beam reflected from the first surface of the first prism.

The spectra of different metals, like sodium, thallium, etc., have also been made use of. E. Rose invented in 1863 his polariscope, or color-measurer, which is much lauded by Helmholtz and Pflüger. The principle is to compare two complementary colors produced by a quartz plate cut at right angles to its optic axis between a Nicol's prism and an Iceland spar.<sup>2</sup> The patient if color-blind will find on turning the prism that in a certain position the two complementary colors are equal, which shows at once what colors are confounded by him. An instrument of a similar kind was constructed by Helmholtz and called by him the leukoscope. As both these last instruments have not been used much and are expensive, the reader is referred to the original papers<sup>3</sup> for a full description.<sup>4</sup> A similar instrument is the chromatophotometer of Chibret,<sup>5</sup> in which also complementary colors are compared with each other, with this advantage, that the colors may be given any degree of saturation desired. Here the quartz plate used is cut parallel to its optic axis.

---

<sup>1</sup> Color Measurement and Mixture, 1891.

<sup>2</sup> Helmholtz, loc. cit., p. 372.

<sup>3</sup> Virchow's Archiv, Bd. xxviii. S. 30, 1863; A. König, Wiedemann's Annalen, Bd. xvii. S. 990, 1882.

<sup>4</sup> A simple device to convert Javal's ophthalmometer into a good chromatoscope of the same kind is given by Dr. C. Weiland in the Arch. of Ophthal., vol. xxiv., No. 3, 1895.

<sup>5</sup> Bulletins et mémoires de la Société française d'Ophthalmologie, Janvier, 1885.

I. Clerk Maxwell in 1855 first proposed colored segments on a revolving disk for the examination of the chromatic sense. This method has been much used by Woinow since 1870. It gives accurate results, but it requires a great deal of patience, both on the side of the examiner and on that of the examinee, so that it cannot be used for large numbers.

Examinations of the *peripheral* fields for color are very important in cases of acquired color-blindness, whilst they are only of scientific interest in cases of congenital color-blindness. A perimeter is used, or, if this is not at hand, a black board may be taken. The patient's head is fixed, and, one eye being covered, the other is made to look at a white or gray mark in the centre of the perimeter. Little squares of from ten to twenty millimetres' side, if possible differently colored on the two sides, fastened to a blackened wire, are moved along the black background of the arc of the perimeter, and the degree is marked down not only where the color is lost when moved from centre to periphery, but also where it is recognized again when brought from periphery to centre. Red and green are the most useful colors for testing the field, because it is with them that pathological defects first manifest themselves. It is also very necessary that the examiner should determine the field for his different colors on a *normal* person under the *same conditions*, because the pigments of the same name are by no means all alike, nor is the illumination always the same. Thus he will be better able to eliminate the accidental factors and obtain results that will allow accurate deductions.

In testing for a central color-scotoma there are not so many precautions necessary to be observed. The patient is again told to fix the same point as before, and now smaller squares of colored paper of from one to ten millimetres' <sup>1</sup> side are taken. They are first held to either side, and finally on the point of fixation, when in the presence of a marked scotoma the color will be recognized to one or both sides, but not in the very centre. If the defect is only partial, the color will appear not so bright at the point of fixation as to the side of it, for which examination in such a case very light shades of red or green must be taken. The limits of the scotoma may be mapped out in the same way, if the squares are not too large nor their shades too bright.

*Conclusions.*—Looking back over all the different tests mentioned, it seems that at present the *best practical* test for congenital color-blindness is the matching of properly prepared colored worsteds. If large bodies of men have to be examined in a short time it will perhaps be preferable to proceed with the writer's test as it is done on the Pennsylvania Railroad, and make only the final examinations of the men thus singled out by laymen, by Holmgren's method. Of course this latter must be carried out by a well-trained man, for which the Council of the British Medical Association on

---

<sup>1</sup> Cf. Groenouw, in Graefe's Archiv, Bd. xxxviii., 1, S. 28, and Perimetrie, by Ole Bull (Bonn, 1895).



the efficient control of railway servants' eyesight considers a qualified medical man to be necessary who himself must have been found of normal color-sense by a consulting ophthalmic surgeon. Other tests may be used as auxiliary ones, as the pseudo-isochromatic tables of Stilling, the spectroscope test for the finer diagnosis or for reduced color-sense, or the test for central color-vision by Donders's method. And indeed in Holland the government demands this last examination of the central color-sense to eliminate a central color-scotoma. Such a central color-scotoma could, however, be induced only by disease; and with regard to this the Committee remarks that "special tests for color-blindness induced by disease will very rarely be necessary if, as should always be the case, every examination for color-vision is preceded by one for form."<sup>1</sup> The Committee would "*rely rather on the form-test being stringently carried out than on instituting another color-test for this particular class of color-blindness.*"<sup>2</sup> We have, however, already mentioned the possibility that after an accident, concussion of the brain, etc., the color-sense alone may become affected, the visual acuity remaining perfectly normal. It must be further observed that what we call normal visual acuity is a very relative term, so that  $\frac{20}{XX}$ , the usual standard, may in a good light be read by a young person with reduced visual acuity when his real normal standard is  $\frac{20}{15}$  or even  $\frac{20}{10}$ . Such may have been the case with the girl reported by MacGillivray,<sup>3</sup> who had apparently normal visual acuteness and recognized colors perfectly according to Holmgren's method, but had a very small central color-scotoma for red and green, and was unable at three hundred yards to distinguish red from green signals. It seems, therefore, that so-called normal visual acuity is not always a sufficient safeguard, and it is particularly advisable that after an accident such an examination for central color-sense should be gone through in some form or other.

A case of central color-scotoma caused by the abuse of tobacco seen recently was promptly recognized, and its extent demonstrated, by means of the red and ground glasses taken from the test case and a candle. At and within a distance of thirty-three centimetres this man could recognize the red color, beyond it he was color-blind. The test-glasses were thirty-three millimetres in diameter, and when placed at thirty-three centimetres subtended an angle of about six degrees and gave the size of the scotoma, limited to the distribution perhaps of the macular fibres. The man recovered entirely under treatment.

Here it may be of interest to state how the author proceeds with the cases sent to him for a final examination as to color-blindness. The exam-

<sup>1</sup> Report of the Committee, p. 301.

<sup>2</sup> Loc. cit., p. 302.

<sup>3</sup> British Medical Journal, July, 1892.

ination is usually made by the following means and in the following manner, as described in the *Medical News* for August 18, 1894 :

1. The stick or the new test-skeins ; or both.
2. Holmgren's set of one hundred and fifty various-colored skeins will be used, and the proportion of mistakes recorded.
3. Browning's pocket spectroscope will then be used, and the man be directed to describe the colors he sees when looking through the instrument. If color-blind, he will say that he sees but two colors, yellow and blue, with a gray or a neutral band between them.
4. The color-tables of Stilling will then be used ; these are so arranged that on a colored background letters and figures are printed in the confusion-colors of this background so as to be indistinguishable by the color-blind.

It now becomes requisite to test the central vision, and to determine the power to perceive the signal-colors that are used by night.

5. A piece of dark cobalt-blue glass should be used in the trial-frame over each eye separately, and the man be directed to look at the flame of a candle or other small light from a distance of twenty feet. An eye normal in refraction and color-sense sees the light, colored rose or pink, surrounded by a blue halo. To a hypermetrope there may be a blue light, with a ruby-colored ring or halo ; but two colors will always be seen, whilst the color-blind man sees but one color, blue, or a light spot with a blue halo.

6. Donders's instrument has a standard candle in a dark cylinder, with a wooden disk, and pieces of red, green, blue, and white glass so arranged as to be rotated in turn in front of the flame. Here also there is a metallic slide with perforations ranging from one to twenty millimetres in diameter. The man is placed five metres away, and while the colors of the light are changed by rotating the disk he is challenged to designate the colors of the transmitted light. The normal eye recognizes them through the one-millimetre opening at five metres ; or, better still, the candle is so placed that the examiner with normal color-sense just perceives the color through the one-millimetre opening at five metres. The color-blind individual may fail through a series of openings until the twenty-millimetre one is presented. He may still call white green, and red green. If so, he is asked the significance of the green, and answers "caution." He is then requested to approach the light slowly, and as he does this he may perhaps at one metre or one-third of a metre, by its intensity or size, recognize and call it red. Using the same ratio for his color-blindness as we employ for his acuteness of vision, we can reason thus : Full color-sense enables one to see the lights promptly at five metres through the one-millimetre opening ; if the man sees them only after the apertures have been increased, his color-sense must be defective. Thus, if an opening of twenty millimetres is needed, the color-sense =  $\frac{1}{20}$  ; should the man fail with the twenty-millimetre opening at five metres, he is told to approach it, and if he sees it at one metre he has  $\frac{1}{100}$  of color-sense, and if at one-third metre, or one foot, he

has only  $\frac{1}{300}$  of the normal power. The mere diminution of white light by interposing pieces of London smoke may induce the color-blind to pronounce it in turn white, green, and finally red.

7. A tin lantern with a switch-light condenser having a four-inch opening arranged so as to admit of placing pieces of white (ground), green, red, blue, and London-smoke glass before it is now employed. This could also be made to take the place of Donders's instrument, if covered with a front, and with a sliding-piece with small perforations. A man failing to recognize the light from a four-inch aperture leaves no possible room for doubt, and this fixture is useful in convincing the friends of the man, and any railroad officers who may desire a rude test. The light is in diameter one hundred millimetres, and should be seen at five hundred metres.

8. The instrument of Mr. Carter, of London, is then made use of. This is to guard the surgical expert against a hasty opinion, and is to act as a check upon all wool-tests. It is based upon the sensibility of the retina and its power to recognize form and color in various intensities of light. The surgeon and the man examined regard the tests simultaneously, while the quantity of light is varied: in this way possible errors with other tests, especially Holmgren's, can be avoided.

9. In Dr. Chibret's instrument, by means of polarized light various colors may be produced at will. The color-blind betray themselves by placing the instrument so that two dissimilar disks of light appear to them alike.

10. Finally, an assortment of flags that have been in actual use, ten of each color, white, green, blue, and red, are used as a test. These are thrown down in a confused mass on the floor, and the man is directed to assort them properly. Astounding mistakes are often made; as, for example, when a man is directed to take a red flag and use it to protect the rear of a train, he may select a green one.

A profound understanding of this curious defect of color-perception must be acquired to enable the surgical expert to make the best use of these various methods, and, whilst they are sufficient, they are decisive and require but little time. Perhaps the transcript of one case from my record-book may illustrate these brief descriptions:

J. H., employed by the Pennsylvania Railroad Co., forty-three years old; found defective, and referred for final opinion.

Color-stick: With green, selects Nos. 1, 2, 3, 4, 6, 7, 11, 13, 15, 17; with rose, selects Nos. 22, 25, 21, 27, 28; with red, selects Nos. 31, 32, 33, 34, 37.

Holmgren: Green, selects 2 greens and 21 confusions; rose, selects 5 greens, with 13 confusions; red, selects 8 greens, with 9 confusions, 2 greens.

Donders: Fails at 5 m. on all apertures; fails at 1 m. on all apertures;  $\frac{1}{3}$  m. on all apertures; color-sense less than  $\frac{1}{300}$ .

Calls, with 20 mm. opening, green red; red green; and white light red.

He made more mistakes than successes, with gray (London-smoke glass) over white; called it red and green, as light was increased or diminished, and finally declared that he had never seen such lights on a railroad.

Failed with switch-light, 4 inches in diameter, at 5 m. and at 1 m., and manifested a color-blindness or defect greater than  $\frac{1}{500}$ , as he failed to see at 1 m. what a normal eye would recognize infallibly at 500 metres.

Cobalt-glass: Sees white light with blue halo; no red or rose.

Flags: At 1 m. calls dirty-white green; fails to distinguish red from green. He was then told to select from a pile of flags the danger-signal, or red one, and to hurry back and protect his train; with his own hands and deliberately he chose six—three red, two green, and one blue—stating that "they would all stop trains."

Stilling's tables: Fails in all but VII, which should be recognized by a color-blind.

Pronounced color-blind and unfit for any duty in which he would govern his actions with color-signals.

Finally we come to the question of *re-examination for color-blindness*. That color-blindness of the congenital type is never acquired there can be no doubt. Therefore it can be only the acquired form that can appear in an individual who has once successfully passed a carefully conducted examination for color-blindness. As abuse of tobacco and alcohol, concussion of the brain, cerebral disease, diabetes mellitus, albuminuria, syphilis, rheumatism, and even some acute fevers, may produce color-blindness, it seems necessary that the employees should be retested from time to time, say every third year. It would probably mostly suffice, as the Committee thinks, to test the form-sense alone, though in doubtful cases, especially of young men, an ophthalmic examination of the central and peripheral color-vision ought not to be omitted. It seems further desirable that after each accident that may be attributed to defective eyesight the employees involved in it should be tested again as to their visual acuity and color-perception, and that all other witnesses who testify as to the color of a signal should be examined as to their color-perception. But not only the employees, but also the tests used for the detection of color-blindness, as well as the colors of the signals used, should be re-examined from time to time by a scientific expert, as stated before, not only to protect the public properly, but also to insure justice to the men.

# SCHOOL HYGIENE.

BY S. D. RISLEY, A.M., M.D., PH.D.,

Professor of Ophthalmology in the Philadelphia Polyclinic and College for Graduates in Medicine; Attending Surgeon to the Wills Eye Hospital, Philadelphia.

---

SANITARY science can have no more important or fruitful field of application than is presented in our educational institutions. In the school statistics of our Census Bureau, collated under the admirable management of Mr. James H. Blodgett, it appears that during the years 1889-1890 there were in the various schools and colleges of the United States more than fourteen millions of pupils. When we consider that this vast army of students is composed of those to whom the destiny of the nation is to be speedily committed, it is obviously important not only that their mental and moral training should be wisely conducted, but that great care should be exercised to avoid physical degeneracy during the years of school life, which are also the years of physiological growth. It is reasonable to expect that some degree of physical deterioration will result from depriving young children of the freedom of the nursery and playground and subjecting them to the confinement and tasks of the school-room; but observation has shown that a considerable percentage of those who enter upon the educational process in apparently good health soon manifest impaired general vigor, acquire distorted spines, and develop near-sight. It is plainly important, therefore, that due regard should be paid to the hygienic environments of the children, and that the work of the schools should be so regulated that it shall rest as lightly as possible upon the growing child. It does not fall within the design of this paper to consider the subject of general hygiene, except so far as it has a more or less direct bearing upon the vision of the school-children. The important questions, therefore, relating to educational methods and the general sanitation of school-buildings will be dismissed from any extended consideration, and attention will be devoted to the nature and causes of impairment of vision during the years of school life.

## PART I.—DEFECTS OF VISION IN THE SCHOOLS.

It was recognized at the beginning of the present century that the requirements of school life resulted in injury to the eyes of many of the children. A. G. Beer published a treatise on "Healthy and Weak Eyes"

in 1800, in which many important hints to teachers are given. (Cohn.) In 1813, James Ware, of London, published his well-known investigations, in which is found the first allusion to the relation between the myopic eye and the demands of civilized life that has come under my notice. No other examinations seem to have been made until those by Szokalski in Paris, in 1848. These were followed in 1856 by the published investigations of Sehurmayr in Baden, in 1861 by those of Von Jaeger in Vienna, in 1866 by those of Rueta in Leipsie, and in 1867 by those of Reek, Alexander, Gaertner, and Cohn. The examination of the eyes of ten thousand and sixty children by Cohn in the schools of Breslau and vicinity, and the published results of his extensive investigation, gave a great impetus to the discussion of the subject of school hygiene. So numerous were the examinations made by different observers, that in 1885 Randall collected the published records of one hundred and forty-six thousand five hundred and twenty-two examinations, and at the present time more than two hundred thousand pupils of all grades have been subjected to a more or less critical study of ocular conditions, particularly as to the relative frequency of emmetropia, hypermetropia, and myopia. (Fig. 1, *b*, *a*, and *c*.)

FIG. 1.

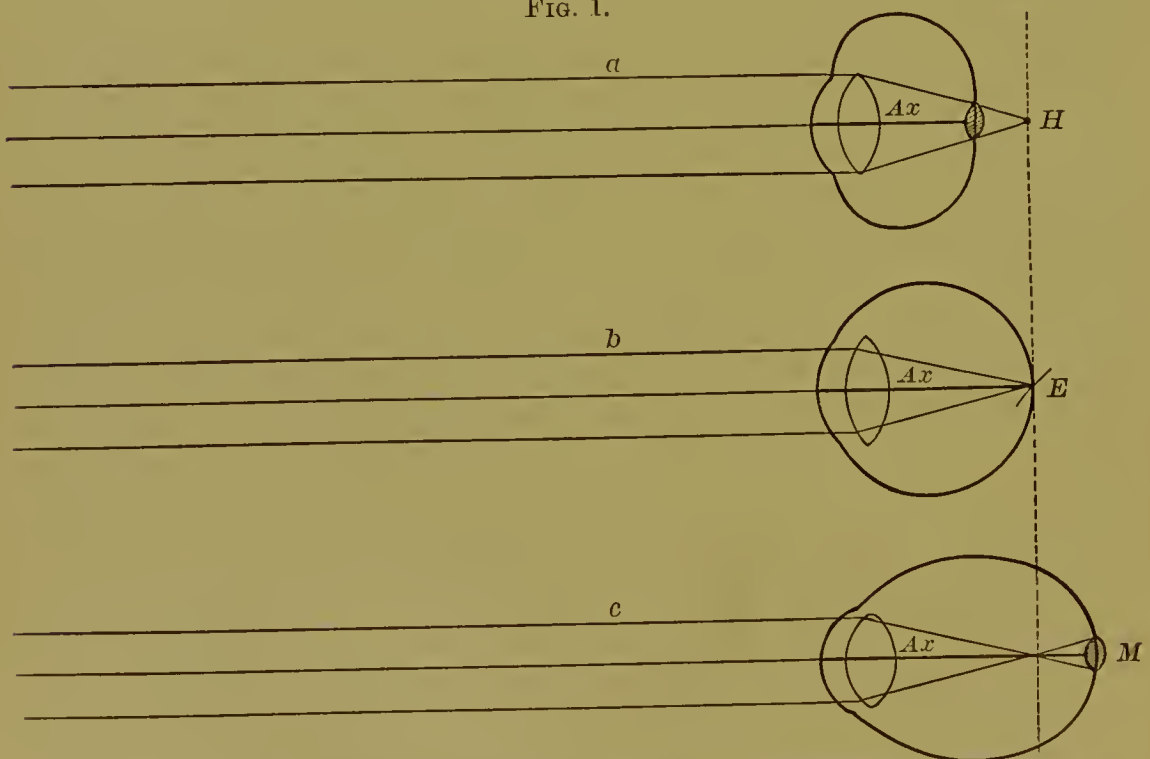


Diagram illustrating the refraction of parallel rays of light in hypermetropia (*a*), emmetropia (*b*), and myopia (*c*).

The results of the great labor bestowed upon the collection of these voluminous statistics are too well known to need any detailed presentation or any extended reference to the bibliography. Stated in general terms, it was shown that the eyes with hypermetropic refraction greatly outnumbered the emmetropic and myopic eyes, particularly during early childhood; that the emmetropic eye was comparatively rare, but that the state of refraction most nearly approaching this ideal condition retained an almost uniform

percentage throughout school life; that myopia, extremely rare or entirely absent before the beginning of the educational process, was found to advance steadily in percentage with the progress of the pupils in the schools, while the percentage of hypermetropia diminished in approximately the same degree. Figs. 2 and 3 will serve to illustrate this general truth as set forth in the published statistics. The figures on the left of the diagram

FIG. 2.

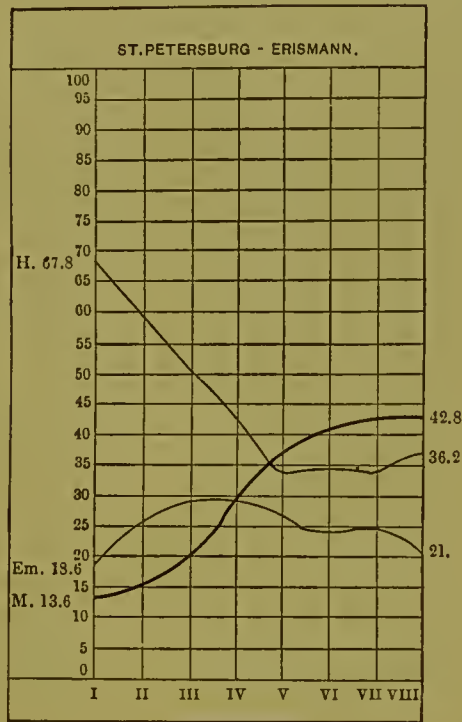
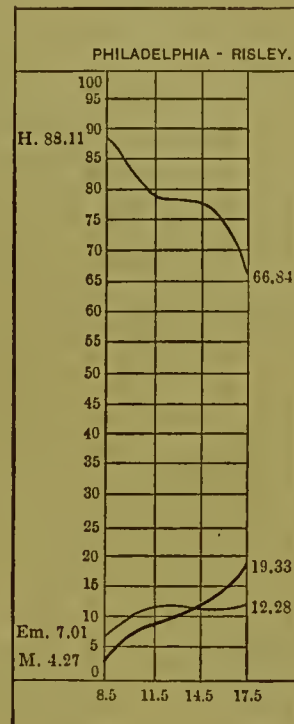


FIG. 3.



refer to percentages, while those at the bottom represent the age or advancement in school life. *H.* = hypermetropia, *Em.* = emmetropia, and *M.* = myopia. With varying results as to actual percentages, due in part to different standards and to different methods pursued in the investigation, the same general truth was set forth with remarkable uniformity in the work of all observers. In Cohn's statistics the following progression in the percentage of myopia was shown in the various schools examined by him:

School Type	Percent. of Myopia.
Five village schools . . . . .	1.4
Twenty elementary schools . . . . .	6.7
Two higher girls' schools . . . . .	7.7
Two intermediate schools . . . . .	10.3
Two realschulen . . . . .	19.7
Two gymnasiums . . . . .	26.2

Among the students of the university he found that the percentage of myopic eyes had advanced to 59.5. He very properly concludes, therefore, that not only does the number of short-sighted pupils increase from the lowest to the highest schools, but that the increase is in direct proportion to the length of time devoted to the strain of school life. Allowing the

work of Professor Cohn to stand as representing the main truth, verified by a large number of European observers, we turn to the work done in this country. It will be observed in these statistics that there is also a continuous progression in the percentage of myopia in the American schools as we proceed from the lowest to the highest grades. In the following table (Table I.) only the work done by American observers is presented,

TABLE I.  
WORK OF AMERICAN OBSERVERS.

Year.	Observer.	Locality.	Age.	Institution.	No.	Per- cent. M.
1875	Callan.	New York.	5-19	Negro Schools.	457	3
				Primary Department.	?	.
				Grammar Schools.	?	5
1876	Loring and Derby.	New York.	6-21	Primary Schools.	205	7
				District Schools.	249	12
				Normal School.	679	27
				Children of Germans.	..	24
				Children of Americans.	..	20
				Children of Irish.	..	14
1877	Williams and Ayres.	Cincinnati.	?	District Schools.	630	10
				Intermediate Schools.	210	14
				High Schools.	210	16
1877	Agnew.	New York.	?	New York College.	579	39
				Brooklyn Polytechnic.	300	19
				Academic Department.	142	10
				Collegiate Department.	158	28
1877	H. Derby.	Boston.	15-24	Amherst College.	1880	28
				Howard College.	122	29
1877	Bacon.	Hartford.	7-17	District Scholars.	308	16
1877	Stevens.	Hartford.	7-17	District Scholars.	675	18
1881	Risley.	Philadelphia	8½-17½	Primary Schools.		
				Average age, 8½.	228	4
				Average age, 11½.	228	9
				Grammar Schools, age 14.	430	11
				Normal Schools, age 17½.	553	19
1882	Mittendorf and Derby.	New York.	. . .	Primary Schools.	203	3
				Grammar Schools.	698	8
				Grammar Schools.	896	13
				College Students.	201	35
1883	H. Derby.	Massachusetts.	21-26	Amherst College.	254	47
1884	Gardner.	Springfield.	?	Several Schools.	1082	9
1885	Randall.	Philadelphia.	19-34	Students of Medicine.	90	10
1887	Tiffany.	Kansas City.	?	Different Schools.	2040	5

and it is so tabulated as to show at a glance the steady increase in the percentage of myopia with the advance in age of the pupils. In Table II., arranged from Randall's tables,<sup>1</sup> the work of the same observers is again tabulated, the percentage of other states of refraction being also shown. (See Table II.)

It is plain, therefore, that the same problem confronts us in the United States as was presented for solution to European observers. Although the percentage of myopia is not so high among advanced students and in the

<sup>1</sup> American Journal of the Medical Sciences, July, 1885.



TABLE II.  
WORK OF AMERICAN OBSERVERS.

Date.	Examiner.	Character of Examined.	Age.	Per- sons.	Eyes.	Em.	Per- cent.	M.	Per- cent.	Em.	Per- cent.	H.	Per- cent.	As. and Amb.
1875	Callan.	Negro Primary and Grammar School, New York.	5-19	457	..	81	17.7?	12	2.6	289	67	350	76.5	..
1876	Loring and Derby, R. H.	Pupils various schools of New York.	6-21	..	2265	1531	67.59	448	19.78	286	12.63	?	?	..
1877	Bacon.	District scholars, Hartford.	7-17	308	616	464	75.3	102	16.5	..	..	..	..	..
1877	Steven.	District scholars, Hartford.	7-17	675	..	..	..	120	18	..	..	..	..	..
1877	Agnew, Williams, and Ayres.	Primary District Schools, Cincinnati.	..	630	..	507	80.5	85	13.5	37	6	..	..	..
1877	Agnew and Cheatham.	College students, New York.	..	549	1097	651	59	333	30.3	105	9.6	..	..	..
1877	Agnew, Prout, and Mathewson.	Technical Institute pupils, Brooklyn.	..	300	600	372	62	79	12.5	126	21	..	..	..
1877	Derby, Hasket.	College freshmen (Harvard), Boston.	..	122	..	..	..	36	29.5	..	..	..	..	..
1878	Roosa.	Medical students and graduates, New York.	21-34	14	..	3	22	..	..	..	..	11	78	..
1879	Derby, Hasket.	College freshmen, Amherst.	15-24	321	..	145	45.2	114	35.9	67	20.9	?	?	..
1880	Ely.	Infants, New York.	1-60 d.	111	154	21	14	27	18	..	..	106	69	..
1881	Risley.	Pupils various schools, Philadelphia.	6-21	1212	2422	272	11.2	332	13.7	..	..	1792	74.1	As. (1330)
1882	Fox.	American Indian pupils, Carlsic.	8-22	250	..	237	94.8	6	2.4	4	1.6	..	..	..
1882	Mittendorf and Derby, R. H.	Primary pupils, New York.	..	203	..	162	80	6	3	35	17	..	..	..
1882	Mittendorf and Derby, R. H.	Grammar pupils, New York.	..	698	..	555	79.5	59	8.5	84	12	..	..	..
1882	Mittendorf and Derby, R. H.	Grammar pupils, New York.	..	896	..	..	..	119	13.5	..	..	..	..	..
1882	Mittendorf and Derby, R. H.	College students, New York.	..	201	..	..	..	69	35	20	10	..	..	..
1883	Derby, Hasket.	College graduates, Amherst.	21-26	254	..	87	34.3	120	47.2	47	18.5	..	..	..
1884	Fox.	Indians, girls, pupils, Carlisle.	..	60	110	36	32.7	13	11.8	..	..	48	48.6	..
1885	Randall.	Medical students, Philadelphia.	19-34	90	180	32	18.8	17	9.44	37	26	131	72.77	..

higher classes of our public schools as was shown to exist in the older civilizations of Europe, nevertheless the fact of its steady increase is clearly demonstrated, and in the lower classes it differs but little from that shown in the European statistics.

#### THE SIGNIFICANCE OF MYOPIA.

The full significance of the figures is appreciated, however, only when viewed from the stand-point of the genesis of the myopic eye. It will be seen from any careful study of the statistics of school examinations that the production of myopia was the striking fact presented, and that it furnished a basis of discussion as to the hygienic requirements of the schools. It is worthy of observation that the very frequency and uniformity of its occurrence gave rise to the inquiry in the minds of some as to whether myopia was to be regarded as an evil: was it not rather a manifestation of normal evolution? In confirmation of this proposition the well-known facts were cited that the small or hypermetropic eyeball (Fig. 1, *a*) is always present in animals, in infants, in the uncivilized races, and in those who pass their lives in employments of the grosser sort, while myopia (Fig. 1, *c*) is almost unknown under these conditions of life. In the statistics of school examinations it was shown that at the beginning of school life hypermetropic eyes were more numerous than both emmetropic and myopic combined, but with the increase in the percentage of myopia it was found that the percentage of hypermetropic eyes diminished in approximately the same ratio, the intermediate emmetropic eyes remaining in nearly uniform percentage through all the classes. The figures seemed to teach that the refraction of the human eye steadily increased during the years of school life, which are also the years of growth in stature. This suggested the possibility that with the growth of the body the small hypermetropic eyeball of infancy and childhood was also outgrown,—*i.e.*, developed into the larger emmetropic ball,—and this, under the strain imposed by the requirements of school life, passed into the large myopic eye; some even maintaining that it was, in fact, better adapted to the exigencies of civilization than either the emmetropic or the hypermetropic eye. In a word, the change of refraction was to be regarded as a process of normal evolution, “an appropriate adaptation to the act of work.” In this connection it should be remembered, however, that the adult Indian, the farmer, and the day-laborer do not outgrow their hypermetropia, and that the myopic eye results only under the stress of those employments which require the protracted use of the eyes at near-work. Moreover, myopia is not a characteristic of the student any more than of the artisan whose trade requires accurate near-vision, provided only that his work was begun early in life. The editorial sanctum, for example, is no more liable to develop myopia than the composing-room. Cohn found fifty-one and a half per cent. of near-sight among the composers of Breslan, and I have myself frequently witnessed the most malignant forms of progressive

myopia among compositors, joiners, and brass-turners in Philadelphia. Therefore it must be shown that the increase in the refraction of the eye is consonant with the health of the organ, and that it is conducive to greater comfort and usefulness to the individual, before we can accept the view which regards the myopic eye as a manifestation of normal growth, or of "an appropriate adaptation." If in either or both of these respects demonstration is wanting, or if the contrary should appear on sufficient investigation, then the increasing percentage of near-sight in the community must be classed among the baneful physical results of our civilization.

That this increase of refraction in the human eye is not a physiological process finds ample demonstration in many simple facts open to common observation. In communities where the vocations are of such a nature as to demand but little accurate vision, the necessity for care of the eyes is not felt, since the strain at near-work in ill-lighted rooms is not required. Examples are found in farming districts and among those engaged in the coarser mechanical pursuits. If the children from these communities are sent to school, or into the counting-rooms of mercantile establishments, or are placed at some mechanical employment demanding accurate vision for many hours daily, the problem of how to prevent injury to the eyes soon obtrudes itself. When we study the nature of the ensuing injury which may befall the school-child, the clerk, or the artisan, we find first of all that it is attended with certain subjective symptoms,—*e.g.*, headache, painful eyes and impaired vision, undue sensitiveness to light, and increased lacrymation,—all the symptoms being aggravated by work at the near-point or by exposure to strong light. A careful study reveals, during the early history of these eyes, *a more or less tonic cramp in the accommodation, injected external tunics, and great hypercemia of the optic nerve, retina, and chorioid.* The subjective symptoms, together with the intra-ocular hyperæmia, subside under rest, but recur when work is resumed. If the refraction is *myopic*, the degree of myopia steadily advances, and is attended with certain intra-ocular changes of an unquestionably pathological character, which also steadily advance with the increasing refraction. If the eyes are *hypermetropic*, they have been observed, in a large group of cases to be hereafter noted, to increase their refraction; but in each instance the increase was attended with advancing pathological conditions of the intra-ocular membranes of the same nature as those observed in the myopic eyes. It is obvious, therefore, that the process of change in the form and refraction of the eyes is not physiological in character. The more closely we study individual examples of increasing refraction the more forcibly does the pathological significance force itself upon the attention. These studies of individual cases shed much light upon the school statistics, since the observed conditions are the same as those which at a later stage are characteristic of the eye with progressive near-sight. It is, for example, shown in the admirable studies of Erismann in the schools of St. Petersburg (Fig. 2) that in twelve hundred and forty-five short-sighted pupils there

were but five per cent. who were free from pathological conditions of the chorioid. Of eighteen hundred and seventy-eight myopes observed by Horner, thirty-four per cent. developed dangerous complications,—in nine per cent. diseases of the vitreous, in eleven per cent. inflammations of the chorioid, in four per cent. detachment of the retina, and cataract in twenty-three per cent.<sup>1</sup> In my own work in the schools of Philadelphia, sixty per cent. of the eyes with myopic astigmatism had chorioidal atrophies or inflammation, usually at the temporal margin of the optic nerve, eighty-seven per cent. exhibited varying forms of chorioidal disease, and seventy per cent. were asthenopic. (Figs. 5 and 6.) While it is obvious from the foregoing statements that the myopic eye must of necessity be recruited from the other states of refraction, the weight of clinical experience is certainly opposed to the view which would regard the change as a physiological growth.

In this discussion we may fairly dismiss from consideration the extremely rare congenital myopia, as it is obviously not this, but the acquired and progressive form of near-sight, which is found in increasing percentage in the schools, and which, therefore, interests us here. In these eyes it has been shown that the increasing refraction is brought about by a distention or stretching of the tunics of the eyeball, and the most painstaking study has served only to demonstrate more and more forcibly the pathological character of the process. The important lessons which were taught by the four cases published by Arlt in 1853, and by the careful study by Jaeger of the changes which occur at the entrance of the optic nerve in the distending myopic eye, are fully in accord with clinical experience in the treatment of these eyes, and also with the excellent early teaching of Donders,—viz., “the progressive elongation and progressive short-sight advance together, and this advance is an actual disease. I maintain without hesitation that a short-sighted eye is a diseased eye. . . . Progressive short-sight is in every case ominous of evil for the future, for if it remains progressive the eye soon develops painful symptoms and becomes less equal to its work; and not infrequently, at the age of fifty or sixty, if not much earlier, the power of sight, either from detachment of the retina, or from hemorrhages, or from atrophy and degeneration of the yellow spot, is irrecoverably lost.”<sup>2</sup> If, then, we come to regard increasing refraction in the human eye as a manifestation of disease, the figures in the school statistics acquire a vital significance when viewed from the stand-point of school hygiene.

The obvious association of the increasing percentage of myopia with the work of the schools seemed naturally to fix the responsibility for the disease upon the educational process, and led directly to efforts for the discovery and reform of faulty educational methods. Much care was devoted

---

<sup>1</sup> Vide Cohn, *Hygiene des Auges*.

<sup>2</sup> Cohn, *Hygiene of the Eye*, English ed., p. 49.

PLATE I.

No. I.



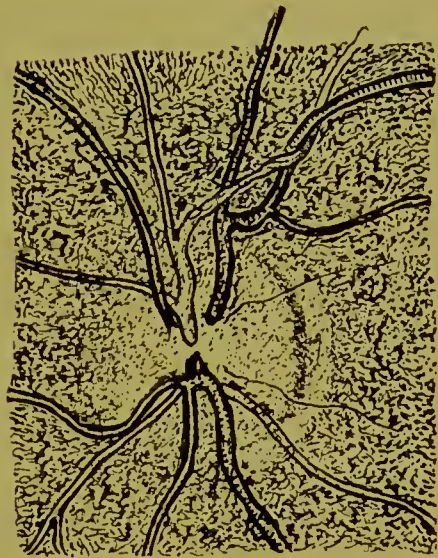
No. II.



No. III.



No. IV.



No. V.



Pen sketches of crescents of chorioiditis at the temporal margin of the optic nerve in asthenopic eyes with hypermetropic astigmatism and increasing refraction. Nos. IV. and V. have already acquired a low degree of myopia.



to the proper ventilation, lighting, and furnishing of the school-houses; while the type employed in the printing of school-books, the script used in writing, and the position assumed by the children at their work were subjected to the most rigid scrutiny. But, notwithstanding the introduction of much-needed reform in all these matters, the injurious results of the educational process were not notably arrested.

In this connection another notable fact, set forth in the statistics of Professor Cohn and others, is of much importance,—viz., *that not only the percentage but also the degree of near-sight was progressive.* In the course of a year and a half the average degree of myopia was found, on a second examination of the same pupils, to have advanced from 2 D. to 2.75 D. Of fifty-four myopes still in the Frederiek Gymnasium at Breslau, twenty-eight had suffered a decided increase in their myopia. Von Reuss also re-examined in three succeeding years the eyes of the same pupils, still remaining in the Leopoldstadt Gymnasium in Vienna, and found that after three years in only twelve per cent. of them had the myopia remained stationary. At the close of the first year the refraction of all eyes had increased in forty-seven per cent. of the pupils examined; at the close of the second year, in fifty per cent.; and after three years, in sixty-one per cent. (Cohn.) These results were confirmed through repeated examinations of the same eyes in other localities by Erismann, Reich, Ulrich, Adamuk, and Just. Dr. H. Derby (Table I.) examined two hundred and fifty-four students at Amherst College, and four years later found not only that the thirty-five per cent. of myopia present at the first examination had increased to forty-seven per cent., but that the average degree of myopia had advanced from 1.8 D. to 2.4 D. These statistics have an added interest from the fact that the pupils examined by Derby were from nineteen to twenty-six years of age, and therefore beyond the years of greatest liability to progression. They were, furthermore, college students, and therefore not subject to the school-room restraints and limitations of the lower schools. It is a significant, though discouraging, fact that the increase as found by Cohn both in the percentage and in the degree of myopia had taken place in those schools where he had especially exerted himself to secure the introduction of hygienic reforms, and the same is true of the observations of Just, who had examined the eyes of twelve hundred and twenty-nine of the pupils in the two High Schools of Zittau, in both of which the hygienic conditions were all that could be desired. He found, nevertheless, that the excellent arrangements had not in any degree lessened the percentage of increase in myopia. It became necessary, therefore, to look beyond faulty hygienic environments for the cause of the pathological states represented by myopia.

A closer approach to the problem of the arrest of myopia in the schools has served to invest it with increased difficulty. Reasoning *a priori*, since only a certain percentage of the children acquired the steadily distending ball, with its accompanying disease, it was probable that the

cause of injury would be found in some peculiarity of structure in these eyes, or possibly in some special liability to disease in those affected.

#### HEREDITARY PREDISPOSITION AND CONGENITAL ANOMALIES IN THE FORM OF THE EYEBALL.

The wide-spread popular impression that near-sight is handed down from parent to child has directed attention to heredity as a probable foundation for the malady. The peculiar difficulties which stand in the way of adequate investigation of hereditary influence have, up to the present time, prevented any sufficient statistical answer as to its importance. The early statement by Arlt, "That short-sight itself cannot be looked upon as hereditary, but only the tendency to short-sight," must for the present be accepted as expressing all that can be claimed for the doctrine of heredity, and it is probable that even this tendency is explained by certain peculiarities in the congenital form of the eyeball itself, or possibly by certain anomalies in the form of the orbit, as urged by Stilling, or in the length of the optic nerve, as suggested by Hasner, Emmert, and Weiss.

Cohn found in one thousand and four myopes that only two and seven-tenths per cent. had a near-sighted father or mother. My own observations, made in the routine of professional work, have thus far shown that the children of myopic parents have more frequently been sufferers from hypermetropic astigmatism, and that myopic children have quite as frequently had parents afflicted with hypermetropic as with myopic refraction. It is rare, however, to find myopic children in families where both parents have normal eyes. Much clinical material could be brought forward to substantiate the above statement, were it within the scope of this paper to enter upon the critical study of the myopic eye.

The most cursory observation will show that physical perfection is not a characteristic of any class of school-children. Distorted skulls, crooked noses, bowed legs, etc., are by no means rare exceptions. The statistics of school examinations abundantly demonstrate the fact that the eyes are also involved in this physical degeneracy from anatomical standards. The skull is especially liable to great variation in form, as inspection of a hatter's forms will show, many of them being so curiously shaped as to appear almost grotesque when compared with the diameters of a model skull. It is probable that certain distortions in the form of the skull affect the shape of the orbits, and that any marked change in the plane of the orbital walls would have a tendency to modify the size and form of the eyeball. That this is true I have had the opportunity to observe in a number of instances of high degrees of astigmatism and anisometropia. A slight distortion in the curvature of the cornea, or a few millimetres' shortening in the antero-posterior axis of the ball, introduces more or less serious disturbance of function, since the dioptric system of the astigmatic eye can cast only imperfect images upon the retina. The struggle to improve the sharpness of vision by accommodative effort causes undue



strain upon each eye, and disturbs also the proper relation between accommodation and the binocular balance. The irritation and hyperæmia caused by these anomalous conditions, sooner or later, in a large number of individuals, set up the pathological states which lie at the foundation of progressive near-sight. Therefore it would seem that if heredity has any important place in the history of the near-sighted eye, it lies in the reproduction of these anatomical defects. I am of the opinion that the congenital anomalies in the form of the eyeball are hereditary rather than the myopia itself or any tendency to myopia. The shape of the family skull, upon which the family likeness so largely depends, is handed down with more uniformity than, possibly, any other anatomical peculiarity.

Observations are not wanting which demonstrate clinically the important relation these anomalies, particularly astigmatism, bear to the production of myopia. Dr. W. F. Norris has published the records of eleven carefully observed cases, in each of which the advancing refraction was demonstrated by continuous observation extending over a number of years, and by repeated measurements of the static refraction of the eyes, made under the use of strong mydriatics. Astigmatism was present in all, and in each case there was demonstrable chorioidal change.<sup>1</sup> That this is the history of some cases of progressive myopia I also have had opportunity to witness in a considerable number of patients, the detailed records of which have been published in seventeen cases: in 1880 a group of four cases in the *American Journal of the Medical Sciences* for October, in 1884 a fifth case (*Transactions of the American Ophthalmological Society*, vol. iii. p. 751), three additional cases in 1885 (*loc. cit.*, vol. iv. p. 102), and in 1887 nine cases (*loc. cit.*, vol. iv. p. 520). Adding these seventeen cases to the eleven observed by Norris, we have twenty-eight examples in which the change of refraction was observed through a series of years, and the static refraction of each eye repeatedly demonstrated by the rigid employment of a strong mydriatic for many days. Since the publication of these cases I have seen a much larger number presenting similar histories. *My own cases, without exception, passed from the hypermetropic ball over into near-sight through the turnstile of astigmatism.* In all of them the observed changes of refraction were attended with pain and symptoms of external irritation,—*e.g.*, blepharitis, conjunctival hyperæmia, increased lacrymation, undue sensitiveness to light, etc.,—while the ophthalmoscope revealed advancing pathological changes in the chorioid. *In no instance did these eyes, in passing from hypermetropia into myopia, become emmetropic at any stage of their progress.* It would seem, therefore, that the inherited congenital anomalies of refraction, particularly astigmatism, are responsible for the myopic eye, by virtue of the pathological changes they occasion in hard-worked eyes, rather than any inherited predisposition to disease.

In the routine of professional work the study of the very obvious rela-

---

<sup>1</sup> *Transactions of the American Ophthalmological Society*, vol. iv. p. 369, 1886.

tions between asthenopia and the anomalies of refraction and accommodation has served to confirm the teaching of Donders (*vide* p. 360), while increasing experience in the management of these cases has shown that the asthenopic symptoms are attended by hyperæmia or actual disease of the ocular membranes as the result of eye-strain. Careful repeated studies of individual cases, as noted above, have demonstrated that, for these cases certainly, the tender, readily yielding sclera of youth had distended under the strain, and the probable increase of tension, produced by the prolonged turgescence of the intra-ocular tunics, thus bringing about the observed increase in the refraction. What was true of these carefully studied cases was doubtless true of many others also, and seemed to furnish a sufficient explanation of the facts set forth in the school statistics.

In the various studies different observers had assumed that in the process of evolution the short hypermetropic eyeball (*a*, Fig. 1) must have passed through the intermediate stage of emmetropia (*b*, Fig. 1) into the long myopic eye (*c*, Fig. 1). If this were true, it would be reasonable to expect that in the approximately emmetropic eyes would be found the more or less pronounced forms of disease which are recognized, when seen at a later and more advanced stage, as characteristic of progressive myopia, —*e.g.*, chorioiditis and conus, or posterior staphyloma,—while the incipient steps of the process would be first seen in those hypermetropic eyes which were destined to become myopic. Furthermore, these eyes would in all probability have been the subjects of asthenopia, thus revealing their condition and probable future by discomfort at work.

#### THE EXAMINATION IN PHILADELPHIA SCHOOLS.

With these possibilities in mind, opportunity was secured, through the courtesy of the Board of Public Education, to examine the eyes of the children in the various grades of the Philadelphia public schools. The investigation was undertaken with the assistance of the following corps of thoroughly competent associates, to each of whom was assigned a definite part in the examination of every pupil: Dr. James A. Wallace, Dr. Charles A. Oliver, Dr. J. T. Eskridge, Dr. Heilman, Dr. L. B. Hall, and Dr. F. M. Perkins.<sup>1</sup> In arranging and elaborating the work for publication I was greatly indebted to Dr. B. A. Randall, who has since done such valuable work in independent examinations and in collecting the extensive statistics of school examinations. The following details of the method pursued are condensed from the report of the work then made.<sup>2</sup>

In order to give the statistics a true value, the utmost care was exercised throughout to avoid inaccuracy. The examinations were made without the

---

<sup>1</sup> Included in the statistics are the results of the examinations made by Dr. Edward Jackson in the schools of West Chester. The work was conducted in the same manner in all respects as in the Philadelphia schools, and his results were recorded on the same blanks as those there used.

<sup>2</sup> Transactions of the Medical Society of the State of Pennsylvania for 1881.

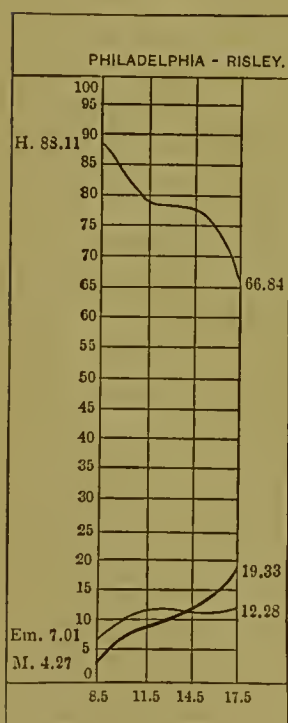
use of a mydriatic, but everything else was done to secure an accurate diagnosis of the existing state of refraction. In order to preserve as complete a record as possible of each individual, a blank form was prepared for noting all the principal features of the case. Upon it were recorded the age, the sex, complexion, color of hair and eyes, the state of the general health, and the condition of the eyes. Under the latter head were recorded whether the eyes were comfortable or weak when used, the presence of blepharitis, conjunctivitis, corneal macula or strabismus, or any other condition or fact bearing upon the special or general medical history of the case. The sharpness of vision, as shown by Snellen's test-types, was then carefully recorded for each eye separately. The probable presence or absence of astigmatism was tested by means of Dr. Green's astigmatic charts. If lines were unquestionably seen better in a given meridian than elsewhere, the direction selected was recorded in degrees. The range of accommodation was carefully taken with fine type,—D. = .50,—the near-point only being recorded, except in cases of myopia of 2.50 D. or more, in which case the remote-point was also recorded. The presence or absence of muscular anomalies was then determined and noted.

With the paper upon which all these data had been recorded, the pupil entered the dark room for the ophthalmoscopic examination, which was made in the most painstaking manner, and with the aid furnished by the facts previously ascertained. The refraction was determined by the ophthalmoscope with all possible care, and any existing error and its apparent extent were recorded. Then the fundus oculi was studied in detail and all notable changes accurately described, and, where permitting of representation, such changes were sketched upon the paper. As it was upon the ophthalmoscopic determination of the condition of refraction that most of the subsequent work hinged, it will be proper to state that all sources of error were excluded with great care. The sharpness of vision and range of accommodation, as previously recorded, were carefully borne in mind and used as checks to guard against mistakes; and if there appeared to be any inconsistency between them and the apparent condition of refraction as revealed to the ophthalmoscope, care was redoubled to find the source of variation. Thus, if  $V = \frac{20}{XX}$ , myopia was at once excluded. Every means, other than the use of a mydriatic, was employed to remove any spasm of accommodation which might simulate near-sight. With these precautions it often happened that what had at first appeared to be a myopia proved, under the examination, to be emmetropia or even hypermetropia. The record thus obtained was as complete and free from all sources of error as was possible from a single examination, unless a mydriatic had been employed, and upon it I should not have hesitated to venture an opinion or prescribe treatment had that been the object of the diagnosis. The results thus obtained were arranged in tabular form, in the order of classes and schools, from the lowest grade to the highest, and the totals and percentages of the several states of refraction, together with the attending conditions of comfort or discom-

fort, health or disease, for each group, carefully worked out and recorded under the appropriate headings. The grouping, therefore, was as follows: 1, (Em.) Emmetropia; 2, (H.) Hypermetropia; 3, (H. As.) Hypermetropic Astigmatism; 4, (M.) Myopia; 5, (M. As.) Myopic Astigmatism; 6, (Mixed As.) Mixed Astigmatism. Under each group were arranged columns in which were recorded the number and percentage of eyes which were comfortable or asthenopic, vision normal or lowered, healthy or unhealthy, and a special heading for conus; and, lastly, a separate grouping according to refraction only, in which astigmatism was ignored in order to make the resulting curves readily comparable with the statistics of other observers. These tables are omitted here, but the results of the investigation are graphically set forth in the accompanying percentage curves, which are copied from the report then made.

A reference to Fig. 4, in which astigmatism is omitted, shows a steady rise in the percentage of myopic eyes from 4.27 per cent. in the lowest

FIG. 4.



grades, the average age being eight and a half years, to 19.33 per cent. in the Normal School, the average age being seventeen and a half years. Thus it will be seen that, so far as the steady rise in the percentage of myopia is concerned, the work simply confirmed the findings of other observers. The high percentage of hypermetropia, amounting to 88.11 per cent. in the lowest grades and sinking to 66.87 per cent. in the highest, did not accord with the statistics of some observers, but was confirmed by the examinations made under mydriatics. The difference is largely explained by the great care exercised to exclude sources of error arising from the accommodative efforts of the pupils, and by the adoption of a different standard for emmetropia and hypermetropia, the static refraction of the eye being sought for in each case, and even low grades of hypermetropia—*e.g.*, .50 D.—being recorded as H.

The facts set forth in Fig. 4 were not regarded, however, as the most important features of the work, since these had been repeatedly demonstrated and needed no further confirmation. It is interesting to observe that the percentage of myopia is lower than in some of the European statistics, but conforms closely with the results obtained by other Americans.

The significant lessons taught by Figs. 5 and 6 are of a different value, since they shed much light upon the etiology and history of the rise in the percentage of myopia. In Fig. 5 is shown the percentage of intra-ocular disease in relation to the different states of refraction. The eyes were divided into Em., H., H. As., M., M. As., and mixed astigmatism. The upper curve indicates the proportional frequency of unhealthy condi-

tions in eyes of different states of refraction ; and it may be well here to state that in this category were included only distinct departures from health. They varied from retinal irritation, with congestion of the nerve, striation of the retina, and undue hyperæmia of the entire eye-ground with commencing pigment absorption, to marked neuro-retinitis, chorioiditis, and posterior staphyloma. The percentage of these conditions in emmetropic eyes will be seen to have been 31.97, a frequency which is explained in part by the fact that the eyes in two of the lower schools were subjected to outrageous hygienic surroundings, and, further, that the

FIG. 5.

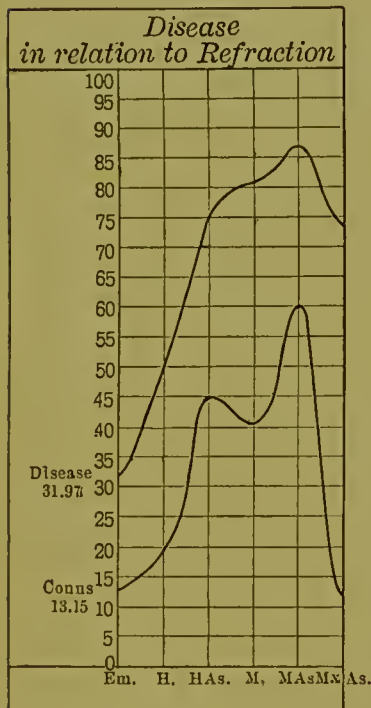


FIG. 6.

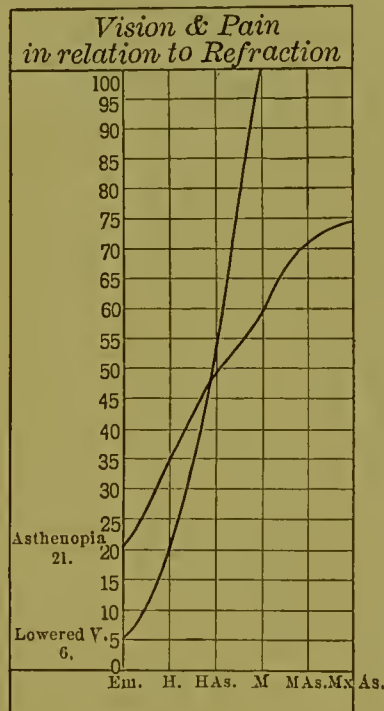
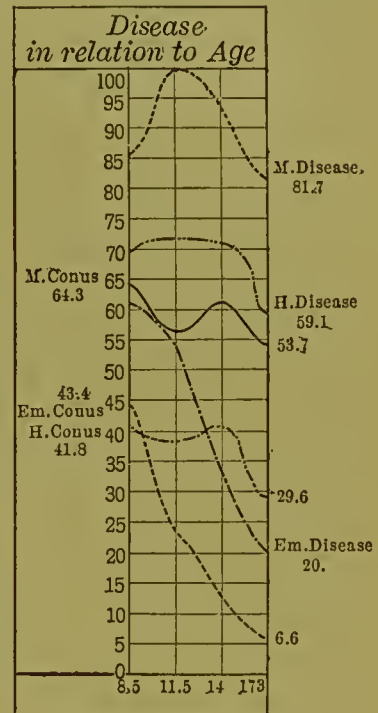


FIG. 7.



other eye of the same pupil was often of a different refraction, or that some form of muscular anomaly was present, and to these causes may justly be charged the diseased conditions in many of the emmetropic eyes. Only twenty per cent. of the emmetropic eyes in the Normal School (age seventeen and a half years) presented these pathological eye-grounds, but here also the difference of refraction in the two eyes of the same individual was present in a large number of cases, thus causing a higher percentage of asthenopia and disease than would have been shown had such differences been eliminated. In hypermetropia the percentage of disease passes fifty per cent. ; in hypermetropic astigmatism, seventy-six per cent. ; while in myopic astigmatism eighty-seven per cent. of the eyes were unhealthy. In the secondary classes there was not found a single myopic eye in which the fundus was healthy ; and even in the Normal School the diseased eye-grounds were present in nearly eighty-two per cent. of the myopic eyes. It would be well to state here that, while some of the classes in the primary and secondary schools had bad hygienic surroundings, and while in the grammar schools the arrangements were not the best, in the Normal

School the greatest possible care had been exercised to secure the best lighting and seating of the class-rooms, with the result of making them as nearly perfect as possible with our present knowledge of the requirements. Yet, notwithstanding this and the fact that the pupils were much older and therefore, as we shall show, less susceptible to unfavorable circumstances, the showing for myopic eyes or those with hypermetropic astigmatism was little better than in the lower schools, except as compared with the two classes noted above. Turning, then, to the lower or conus curve in Fig. 5, it will be seen to occupy a very striking and important relation to the errors of refraction. The curve begins with emmetropia, in which the conus was found, often only in its incipient form, in 13.15 per cent. In this relation the frequent occurrence of anisometropia should also be borne in mind. In hypermetropia it was found in twenty per cent., and where astigmatism was combined with the hypermetropia it rose to forty-five per cent. Simple myopia presented it in but forty-one per cent., distinctly less often than in hypermetropic astigmatism; and only where myopia was itself combined with astigmatism did the percentage of conus rise higher; there, however, to reach sixty per cent. The changes in the eye-ground to which the term conus is here applied were presented in great variety and extent, but, though differing widely in their extremes, were nevertheless regarded here as differing only in degree, not in their essential nature. A study of this pathological condition and its clinical history seems to justify the statement *that it is a limited chorioiditis of varying extent and intensity, affecting the region of the nerve entrance, and generally manifested at the temporal margin of the optic disk as a crescent of altered color and pigment absorption.* The massing of pigment in the ring of chorioid immediately surrounding the optic nerve is a phenomenon often present to an extraordinary extent. So long as these pigment bands and crescents remained undisturbed they were regarded as physiological. When, however, these masses of pigment, or the normal pigmentation about the disk, had partially absorbed, giving rise to crescents of thinned and semi-atrophic chorioid, and the process was accompanied by general chorioidal disease, they were no longer regarded as physiological. The attending symptoms of asthenopia and the clinical history as derived from the individuals where these conditions were found pointed emphatically to a diseased action with a well-marked and more or less permanent anatomical lesion.

These atrophies at the border of the nerve have long been associated with myopia and regarded as standing in close relation to the process of elongation in the myopic ball, as shown by Jaeger. Donders taught, indeed, that a quite uniform relation existed between the degree of the myopia on the one hand and the extent of the zone of chorioidal atrophy on the other. Observation proves, however, that these chorioidal changes, embracing usually the temporal border of the nerve, are by no means confined to myopic eyes, but are also very frequently present in eyes *still* hypermetropic. This is especially true of hypermetropic astigmatism, as

set forth in Fig. 5, where the conus curve rises to forty-five per cent. in H. As., and to sixty per cent. in M. As.

In eyes where this conus is present and the change is still progressive, it is invariably attended with asthenopic symptoms, and with more or less marked general chorioidal disturbance, and must be accepted as evidence of actually increasing refraction, or at best of threatened increase, a contingency controlled largely by the resisting power of the sclera in the individual case and by the industry of the pupil. The figures on Plate I. are reproductions of pen-and-ink sketches of eyes with hypermetropic refraction found in my note-books, made by Dr. Randall, and will serve to illustrate the foregoing remarks. The clinical histories of each case were elaborate and extended over several years.

Nos. I. and II. are from the records of a brother and sister, aged respectively ten and twelve years. Both of them were members of the classes included in the school examination, but were detained from school temporarily because of the bad condition of their eyes, and therefore do not appear in the tables. The conditions here represented were repeated, however, in scores of their fellows at school. Both had suffered severely from their weak eyes and headache, No. II. being subject to petit chorea. Both had hypermetropic astigmatism, and after a few weeks returned to their work with correcting glasses and pursued their studies without further difficulty. These children were followed for several years, but developed no further change in refraction. Their mother had a high grade of H. As., and the father, a post-office clerk, had mixed astigmatism, with a large conus in both eyes, and retino-chorioiditis, with marked asthenopia and so-called "*sick headaches*."

No. III. is a sketch of the condition seen in a lady, aged sixty-eight, with hypermetropic refraction, who had been a life-long sufferer from weak eyes and headaches, which were relieved by glasses correcting her hyperopic astigmatism. The other eye presented similar conditions. There were large areas of pigment absorption throughout the eye-ground, and a general fluffy appearance of the fundus, which slowly subsided under the use of her glasses.

No. IV. is a sketch of the changes seen in a college student, aged seventeen, made in 1877. There was then simple H. As. = .75 D. The severe asthenopia compelled him to abandon his work, which, however, was resumed with correcting glasses and continued comfortably for a year. The glasses were then abandoned, as he thought they were no longer needed. After a term of study without them, the asthenopia returned. The former hypermetropic meridian was then found to be M. = 1 D., and the meridian before emmetropic to be M. = 1.75 D. There was a marked advance in the chorioidal changes, which is carefully described in the notes, but, unfortunately, no sketch was made. Both the first and the later determinations of the refraction were made under the prolonged use of atropine. Correcting glasses were once more prescribed, and two years later there had

been no further increase in the myopia, notwithstanding his continued work at college. The father and mother, a sister, and one brother of this patient were asthenopic, and all had hypermetropic astigmatism.

No. V. is sketched from a case, aged thirteen, of commencing myopia, with astigmatism. The father and a younger brother had hypermetropic astigmatism. The same changes were beginning in the brother, who was also brought for treatment for his weak eyes and headache at school. He was found with a cramp of the accommodation simulating near-sight. It gave way under the use of a mydriatic, and he received convex glasses, correcting a compound hypermetropic astigmatism. Both children received correcting glasses and resumed their school duties. They were kept under observation for two years, but had no return of trouble or increase of refraction.

Plate II. is a portrait of the right eye of a patient under treatment at the Wills Eye Hospital, suffering from violent asthenopia and headache, which were entirely relieved by her glasses, given to correct a hypermetropic astigmatism of low grade. The eye-ground was fluffily throughout, an appearance very difficult to reproduce, and lost in the sketch made for me by Dr. Sehwenk. The commencing macular disease and the crescent of pigment-absorption at the temporal margin of the nerve are seen.

The important rôle played by the errors of refraction, especially by astigmatism, is revealed by any careful study of the curves. (Figs. 5 and 6.) Not only is the well-known fact of the uniform percentage of emmetropia in all the classes again exemplified in Fig. 4, but in Figs. 5 and 6 it is shown that the emmetropic eye enjoyed the highest acuity of vision and was relatively free from pain and disease. As opposed to this claim, it does not suffice to contend that the mathematically emmetropic eye does not exist, for the contention still remains that those eyes most nearly approaching this ideal state of refraction enjoyed in the highest degree immunity from the perils of school life. The eyes with simple H., next to Em., were freest from pain and disease; while simple M., though on the whole very rare,—2.68 per cent.,—stands third. *The rapid mounting of the curves where astigmatism was also present is a fact of the most significant interest in this study.* Its relation to asthenopia and disease is unmistakable as one of cause and effect.

Such relation is, moreover, strongly borne out by clinical experience. In this connection the relative frequency of astigmatism is a point of importance. In the school statistics the following relation was shown :

	Per Cent.
Em. . . . .	11.19
H. . . . .	31.23
H. As. . . . .	42.81
M. . . . .	2.68
M. As. . . . .	11.02
Mixed As. . . . .	1.07
	<hr/> 100.00



PLATE II.



Beginning crescent of pigment-absorption at temporal margin of disk in a case of H + Ah with chorioiditis and asthenopia.



That the frequency of astigmatism was probably underestimated in the school work is shown in the following record of two thousand six hundred and twenty-eight hypermetropic eyes taken consecutively from my case-books, all having been corrected under mydriatics :

H. = 9.70 per cent.  
H. As. = 90.30 per cent.

The percentage of astigmatism is probably higher than would be found in the same number of hypermetropes taken promiscuously from the community, since these had all presented themselves for relief from troublesome symptoms ; nevertheless, the figures serve to illustrate the great relative frequency of this anomaly. The same relation is set forth in Table III., page 376, for myopic eyes, where it is shown that the average percentage for all the years included in the investigation was for

M. = 9.67 per cent.  
M. As. = 90.33 per cent.

The percentage of astigmatism in both hypermetropic and myopic eyes is, therefore, practically identical, a significant fact as pointing to the source of the myopic eye : it would seem, indeed, fair to claim that the latter had been attained through the turnstile of astigmatism, which was already present in the hypermetropic eyes.

In Fig. 7, page 367, a lesson of much significance is taught. Here the percentage of disease and asthenopia in all states of refraction, in relation to the age of the pupils, is made manifest. It will be observed that all the curves make a notable descent as the age of the pupils advances. The explanation is found principally in the facts that, in the *first* place, a certain number of the weakest eyes had dropped out of the schools, and, *secondly*, with advancing age the tissues of the ball were better able to endure the imposed strain of school work. Attention is called especially to the upward trend of the curves in Fig. 7 between the ages of eleven and fourteen, — a fact significant of the bad influence of puberty over the resisting power of the tissues.

The obvious lesson is that our children enter upon their educational training at a too tender age, and that during the first years at school the methods of instruction should be so modified as to avoid as far as possible continuous work at a near-point.

## PART II.—NECESSITY FOR AN ENTRANCE EXAMINATION.

The observed facts set forth in the preceding pages have a very important bearing upon the subject of the hygiene of vision in the schools. It is obvious that if the deductions there made are true, the most painstaking attention to the details of general hygiene of the school-room and the adoption of the most approved educational methods will not suffice to arrest the spread of myopia and its attending pathological conditions.

While the great prevalence of congenitally defective eyes should serve to enforce the necessity for every sanitary precaution, it is nevertheless plain that our first duty is to place specific guardianship over the children who enter upon their educational process with defective eyes. To this end some systematic method of inspection should be adopted in the schools which would be effective, at the very outset, in detecting the anomalies of vision, and at least make it possible to warn the parents of existing unfavorable conditions and of the probable injury to the eyes if neglected.

That children are entered without question as to the state of their vision is doubtless due in large measure to ignorance of any necessity for such inquiry. Parents who are careful of their children's welfare in other respects are unmindful in this, and educators thoroughly versed in the improved methods of mental training accept the important trust committed to them, not knowing whether the vision of the child is sufficient to sustain the coming struggle with books. There is great need, therefore, for popular education in this respect. When parents come to understand that the vision of their children may be defective, and in consequence their school life fraught with danger to the eyes and their educational progress retarded, there will be less negligence in this direction.

When a child is brought for admission to the school, one of the first questions should be, "Have your eyes been tested?" If answered in the negative, such investigation should be urged upon the parents, or made at the time by the teacher or some person detailed for this duty and instructed in the proper methods of examination.

For this purpose professional training is not necessary. The requirements are so simple that any teacher should be able to determine whether the acuity of vision is normal or not. All that is essential for the purpose is, *first*, a chart of standard test letters and a few simple instructions as to its employment; *second*, a small card of clearly printed 4½-point (diamond) type and a metre or foot-rule. The test letters should be placed in a good diffused light, preferably falling upon it from the side, and the pupil stationed at a measured distance of six metres, or twenty feet. He should then be required to name the smallest letters which can be called correctly with each eye separately. The nearest point at which the diamond type can be read clearly should then be determined. On the back of the cards should be printed a table showing the normal near-point for an emmetropic eye at all ages from six to twenty years, together with simple instructions as to the manner of determining it. If the sharpness of vision should prove to be much below the normal, or if the near-point is found too remote for the age of the pupil, admission should be granted only after apprising the parents or guardians of the existing defect of vision and the consequent need of professional advice.

Such inspection would at once eliminate all those pupils with considerable errors of refraction, with corneal opacities, or with serious pathological conditions of the fundus. For children who have not been taught the

alphabet the "illiterate" card of Snellen might be employed, but this is an unsatisfactory method at best. It is probably better to defer the examination until familiarity with the letters of the alphabet has been acquired. In a considerable percentage of cases the impaired vision is due to corneal opacities or intra-ocular disease. These are, of course, in some measure without remedy, but must be left to the direction of professional counsel. Where, however, the lowered acuity of vision is shown to be due to some defect of refraction, this should be corrected by optical means. Happily, the unwarranted prejudice of former years against the use of glasses is rapidly disappearing. Spectacles should be regarded as a protection against harm, a function not essentially different from that of other articles of clothing. *If, at the beginning of the school life, these congenital anomalies of refraction could be carefully corrected by suitable glasses, we should hear much less complaint of the harmful influence of the schools upon the eyesight of our children.* The truth of this statement is borne out by the daily routine of professional work and by the experience of teachers.

Children with red or inflamed eyes should never be permitted to enter the school until a physician's certificate of the non-infectious nature of the disease has been presented. This precaution is especially necessary in our modern school-houses, with their lavatories, where the children find facilities for bathing the hands and face in wash-basins which of necessity must be used by all in common.

In 1875 the Board of Public Education of Philadelphia proposed a series of questions to the teachers in the various schools, one of which was as follows: "How many children in your school are known to you to have weak or sore eyes, or near-sight, or other defects of vision?" Miss Coates closed her reply to this question with the following statement: "You will notice that at present in the Second Division only two pupils' eyes are affected; by the time that class is ready for promotion, as much as one-third of the whole number will be so suffering from weakness of vision as to occasion considerable manœuvring on my part to seat them in such positions as will enable them to copy from the blackboard."

In December, 1893, I asked Miss Dunn, the efficient supervising principal of the Francis M. Drexel School, where she has thirteen hundred and sixty children under her care, to what extent the children suffered from weak or defective vision. She replied, "We have much less trouble in that direction than formerly. Almost daily some child will be sent to me complaining of weak eyes. In all such cases I send them home with a note requesting the parents to have the eyes examined. We miss them from the class for a few days, when they return with a pair of spectacles, and we hear no more complaint." These replies indicate the great advance which has taken place in the popular understanding of the cause of asthenopia since my publication of "Weak Eyes in the Public Schools of Philadelphia," in 1881.<sup>1</sup>

---

<sup>1</sup> Transactions of the Medical Society of the State of Pennsylvania, 1881.

The almost universal resort to correcting glasses in all cases of weak eyes has proved a great boon to the school-children of this city, where the truth of the views which have been expressed is being constantly demonstrated in a broad field of practical application. In a word, when the existing defects of refraction are carefully corrected by suitable glasses, trouble is at an end in the majority of cases of asthenopia. When this is neglected, the asthenopic pupil either spares the weak eyes at the expense of poorly prepared lessons, and, as a consequence, gets on badly at school, or drops out of the contest entirely. If the school work is continued with success, it is done by placing the integrity of the eyes in peril. The following study will serve to demonstrate with much force the value of correcting glasses in preventing the advance of near-sight.

#### THE RESULTS OF THE OPTICAL CORRECTION OF ASTHENOPIC EYES IN ARRESTING MYOPIA.

In seeking for additional light upon the etiology of the myopic eye and the probable value of correcting glasses in arresting the disease, I have made a careful analysis of the recorded cases of myopia treated in my private practice since January 1, 1874. Since the patients were drawn from the more studious and successful portion of the community, it seemed probable that the percentage of myopia in the resulting statistics might be higher than would be shown in the community at large or in the hospital records. In order to avoid misleading conclusions, I secured access to the prescription-books of two large optical companies, and culled from them all prescriptions given for distance glasses,—*i.e.*, formulæ ordered by ophthalmic surgeons for the correction of errors of refraction. These formulæ were from all sources of practice, both public and private, and therefore furnish as accurate data as are obtainable from any source. I was assisted in the analysis of the private case-books by Dr. John T. Carpenter, Jr., while the data from the books of the optical companies were collected for me by Dr. James Thorington.

During the twenty years covered by the resulting table of statistics it has been the almost uniform habit of ophthalmic surgeons in Philadelphia to correct more or less completely and accurately all errors of refraction found in asthenopic patients, in both private and hospital practice. In the analysis of my own books only those cases which were corrected under mydriatics are included. In the analysis of the opticians' books it was not possible to determine this fact. The work covers the correcting glasses for a total of one hundred and ninety-five thousand seven hundred and fifty-four eyes.

It seemed reasonable to expect that if there were indeed a true relation of cause and effect between the congenital anomalies of refraction and progressive near-sight, as has been urged in the preceding pages, the uniform correction of these anomalies in the community for all asthenopic eyes, or even for any considerable percentage of them, would during or after twenty

years reveal the beneficial results of such correction in a diminution both in the percentage of myopic eyes applying for treatment and also in the grade of myopia found. The following tables and percentage curves are instructive not only as showing the results of the analysis made for nearly two hundred thousand eyes, but also as substantially demonstrating the responsibility of congenital anomalies of refraction in the etiology of near-sight, and the value of their optical correction in arresting the disease.

As the design was to ascertain the percentage and grade of M. and M. As. in the several years, the eyes with hypermetropic refraction were not included in the analysis, but simply counted in order to show the percentage of eyes with myopic refraction to the whole number receiving correcting glasses. The degrees of myopia from M. = .50 D. to the highest grades were also recorded, but grouped as follows: 1 D. or less, 1 D. to 3 D., 3 D. to 7 D., 7 D. to 10 D., 10 D. or greater; and these were grouped for the years included as follows: 1874 to 1880 inclusive, 1881-1883, 1884-1886, 1887-1889, 1890-1893. The whole number of eyes for which distance or constant-wear glasses had been furnished by Queen & Co., opticians, and by the Fox Optical Company, were one hundred and eighty-seven thousand and eighteen, of which 21.6 per cent. were for myopic refraction. Of the myopic eyes, as revealed by the glasses ordered, 39.5 per cent. had simple M. and 60.5 per cent. had M. As.

In the private case-books eight thousand seven hundred and thirty-six eyes had received careful correction of refraction errors under the use of mydriatics pressed to thorough paralysis of the accommodation. Of these nineteen hundred and twenty-five were myopic, or twenty-two per cent. Of these myopic eyes, 9.67 per cent. showed only simple M., while 90.33 per cent. were astigmatic. The difference in these percentages is in a measure accounted for by the fact that in my own work astigmatism was carefully sought for and corrected in every case where found, while it is possible that many of the prescriptions prepared at the opticians' were ordered without a mydriatic having been used, or that the lower grades of astigmatism were regarded as unimportant and therefore neglected, especially in the hospital work, which is there included. Then, too, in manifest corrections of irritable myopic eyes the low grades of astigmatism are easily overlooked. The high percentage of astigmatism found in myopic eyes, even the lower percentage—60.5—of the opticians' books, points unmistakably to the important *rôle* that this defect of refraction plays in the etiology of the distending eyeball and of the attending pathological conditions.

In my own case-books it was shown that in many cases a mixed astigmatism was present on one side, while on the other the eye had already passed over into myopia in all meridians, similar pathological conditions being present in both eyes. This is strongly suggested, however, in the table (Table III.) showing the percentage and grades of myopia in succeeding periods of years. It is there shown, in columns 7 to 11, and also in the

TABLE III.

FROM PRIVATE CASE-BOOKS, SHOWING BY YEARS THE STEADY FALL IN THE PERCENTAGE AND DEGREE OF MYOPIA.

1	2	3	4	5	6	7	8	9	10	11
Years.	Number of Eyes.	Number of M. Eyes.	Percentage of Myopia.	Percentage of Simple M.	Percentage of M. As.	M. = more than 10 D.	M. = 7 to 10 D.	M. = 3 to 7 D.	M. = 1 to 3 D.	M. = 1 D. or Less.
1874 } 1881 }	1956	559	28.43	15.5	85.5	2.58	2.36	11.77	9.5	2.3
1881 } 1883 }	1354	308	23.05	15.45	84.55	2.10	1.96	6.92	8.6	2.3
1883 } 1886 }	1376	313	22.07	5.75	94.25	1.67	2.90	8.43	7.8	1.9
1886 } 1889 }	2154	427	19.82	6.50	93.50	1.10	1.20	6.79	7.5	2.7
1889 } 1893 }	1896	318	16.78	5.66	94.34	1.37	1.47	5.27	5.5	3.1
Averages and Totals.	8736	1925	22.03	9.67	90.33	1.76	1.98	7.84	7.78	2.46

curves constructed from it (Figs. 10 and 11), that all the higher grades steadily decrease, while the lower grades, in which are included by far the greater number of the cases showing simple myopic, or mixed, astigmatism, rise in percentage, as shown in column 11. The increase, however, is only relative, as any study of the curves will show. Indeed, there was, in fact, an actual decrease in the number of these eyes also. The obvious lesson taught by the figures in columns 7 to 11 is that the progress of the myopia was arrested by the treatment and by the glasses received, and that there is, therefore, not only a steady fall in the percentage of all myopic eyes, as shown in column 4, but also a steady diminution in the grade of the myopia (columns 7, 8, 9, and 10). The rise in percentage in column 11 is due to the fact that the low grades of myopia were arrested in their progress, and hence did not pass into the higher grades, as in former years. In a word, we are here taught by large numbers of eyes the lesson so obvious in clinical experience, that we have first the asthenopic eye with hypermetropic astigmatism, then the mixed form which passes into the simple, and finally compound myopic astigmatism and progressive near-sight.

The main facts of Table III. are graphically depicted in the percentage curves. (Figs. 8 to 11.) The tables from which the curves representing the work of the optical companies are drawn would have taught the same lesson as Table III., and have therefore been omitted. As was anticipated, the percentage of myopia is somewhat higher in the private work,—only three per cent., however; but it will be observed that the steady decrease in the percentage of near-sight is almost identical in both sets of curves. Thus, in Fig. 8, 1874–1880, M. = 28.43 per cent.,



which steadily falls through the succeeding periods of years to 16.98 per cent. ; and in Fig. 9, commencing at 25.4 per cent., it falls to 15.2 per cent.

FIG. 8.

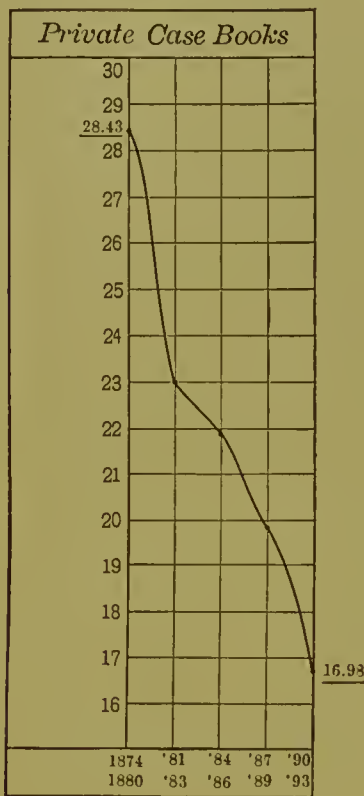


FIG. 9.

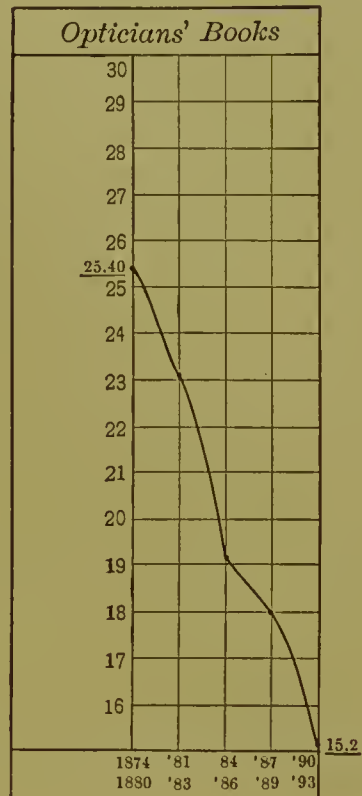


FIG. 10.

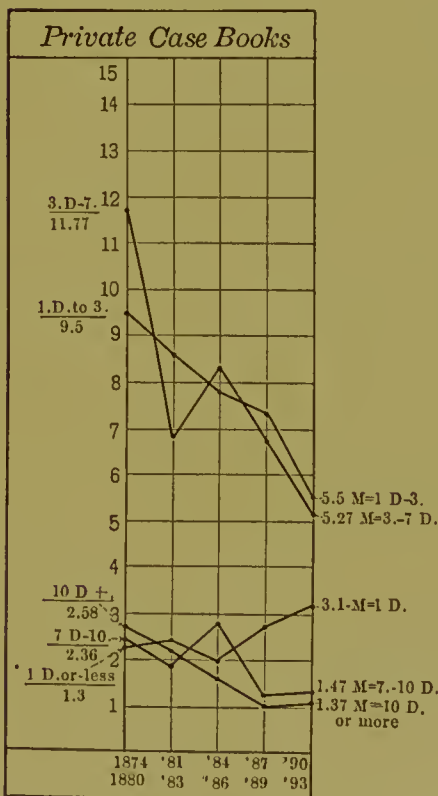
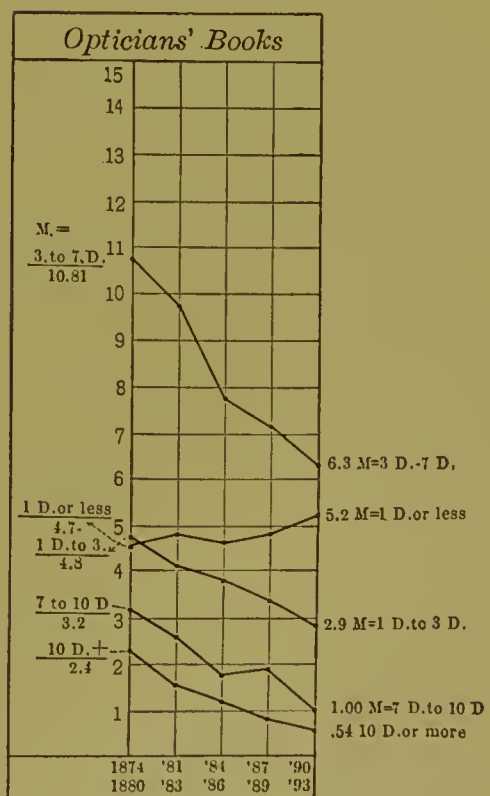


FIG. 11.



Curves showing the steady fall in the percentage and degree of myopia from 1874 to 1893 inclusive.

Incidentally there are also shown in Table III., by years, the percentage of M. and that of M. As. to the whole number of myopic eyes. In the latter

are included all eyes with a near-sighted meridian,—*e.g.*, cases of mixed astigmatism. The percentage of simple M. is seen (in column 5) to fall from 15.5 per cent. in the first period to 5.66 per cent. in the latest period, while the reverse is true of myopic astigmatism, the rise in the latter being in almost the same ratio as the fall in the former. This is accounted for by the greater care with which the astigmatism was sought and corrected as increasing experience taught its importance. The striking fact is the very high percentage of eyes with myopic refraction which are shown to be astigmatic when this defect is carefully sought.

The curves in Fig. 10 are constructed from Table III., columns 7 to 11, and show in the most forcible manner the steady fall in the degree of myopia, except in the grades lower than 1 D., where the curve is seen to rise from 1.3 to 3.1 per cent.; while those in Fig. 11 are constructed in like manner from the tables based upon the books of the optical companies and rise from 4.8 to 5.2 per cent.

The percentage of mixed as well as of simple myopic astigmatism for each grade of myopia is instructive in this connection, as set forth in the following table (Table IV.), which also demonstrates with much force the need for the thorough use of a strong mydriatic in seeking the static refraction of asthenopic eyes. If this precaution is not observed many cases of simple hypermetropic astigmatism will select concave cylinders with the axis at a right angle to that of the proper convex cylinder.

TABLE IV.

SHOWING THE RAPID DECLINE IN PERCENTAGE OF EYES WITH SIMPLE MYOPIC AND MIXED ASTIGMATISM IN GRADES OF MYOPIA HIGHER THAN 1 D. TO 3 D. IN MIXED ASTIGMATISM THE REFRACTION FOR THE MYOPIC MERIDIAN WAS TAKEN AS REPRESENTING THE GRADE OF M.

Grade of M. in Meridian of Highest Refraction.	Mixed Astigmatism.		Simple Astigmatism.	
	Case-Books.	Opticians' Books.	Case-Books.	Opticians' Books.
Less than 1 D. . . . .	38.7	21.	32.6	38.
1 D. to 3 D. . . . .	19.7	11.2	15.1	20.3
3 D. to 7 D. . . . .	4.4	3.2	6.3	7.2
7 D. to 10 D. . . . .	0.	0.	0.	0.
10 D. or more . . . . .	0.	0.	0.	0.

The marked difference in the percentages of myopic and mixed astigmatism between the mydriatic corrections of the private case-books and those of the opticians' books is notable, and shows that without the mydriatics the hypermetropic meridian is overlooked, and the case passes for simple, or possibly compound, myopic astigmatism. For example, in the case-books there were found in M. of less than 1 D. 38.7 per cent. of mixed astigmatism, while in the opticians' books only twenty-one per cent. were found. In simple astigmatism the percentage is higher than in the private work.

It is probable that here many cases of mixed astigmatism had passed for simple myopic astigmatism, since in many instances a mydriatic had not been used.

The result of these studies is to relieve the schools of much of the responsibility for the increase in percentage of near-sight, since the increase is shown to depend upon the strain due to the congenital defects in the eyes which develop it, but nevertheless to emphasize the great need for hygienic precaution, and for some method of inspection which shall detect these defective eyes at the outset of the educational work.

### PART III.—HYGIENE OF THE SCHOOL-ROOM.

Passing from the study of the eyes, we come to the consideration of the hygiene of the school-room, so far as it may affect the vision of the school-children. While there is a wide opportunity for reform in many directions, there has nevertheless been a great advance in school hygiene since 1880. In all the newer school-houses in Philadelphia the light is for the most part adequate and properly arranged. The newer school-desks have been adopted and arranged in accordance with modern teaching. The type in the text-books (especially those employed in the lower grades) is good, and the paper used in most of the books is not open to adverse criticism. In many of the older school-houses, however, glaring defects are still present. The old patterns of desk and seat are still in use, and in many instances are arranged with a plus horizontal distance, while the relation between the height of the seat and that of the desk is not correct. The light in many of the school-rooms is painfully insufficient, even on bright days; but these defects are being remedied as far as the architectural designs of the buildings and financial limitations will permit. I am greatly indebted for courtesies extended by Dr. Edward Brooks, Superintendent of the Public Schools, and by Mr. Paul Kavanagh, Chairman of the Property Committee of the Board of Public Education, and to Mr. Joseph D. Austin, their architect, all of whom have aided me in securing data for this paper. Notwithstanding the earnest co-operation of the Superintendent and the Board of Public Education to secure the best hygienic conditions, there is still much room for reform in our educational methods, viewed from the stand-point of the hygiene of vision.

*A Modified Curriculum.*—Among these reforms the first which suggests itself is the necessity for a more elastic curriculum of study, which will allow the attendance of partially disabled children without demanding of them the urgent pursuit, at the same time, of all the branches of study required of the class to which they belong. It is possible that some system of certified proficiency in as many studies as the individual is able to master safely might be adopted, even in our public schools. Such a curriculum is needed not only for children with defective eyes, but for a very large number who are in more or less feeble health. The effect of such a

course would be to lengthen the time of their school life by a year or more, but would do much to preserve the eyes and general health, and not infrequently would make educational training possible for children who are now forced to relinquish it at a very early age. The physician often finds it necessary to remove young children from school and place them under the care of tutors, or in private schools, where the amount of work required can be strictly under control, the alternative being to stop their work altogether.

*The Work required at Home.*—The large amount of work required to be done at home in the preparation of lessons for the following day is an evil calling for definite modification. The greatest possible care as to the hygienic arrangement of our school buildings and furnishings cannot remove evils which assail the child at home. During the winter months especially, the lessons at home must be prepared by the aid of artificial light, and usually in the midst of the family circle. With rare exceptions, the child will be left to his own arrangement of book and light, and there will be no attention paid to the relation between chair and table, or to the position assumed in reading and writing.<sup>1</sup> Observation and wide inquiry among

FIG. 12.



patients have shown that for both private and public school-children in this community three, and often four, lessons must each evening be prepared at home. When this work is added to that of the sessions of the

<sup>1</sup> The possibilities in reach of the child at home are strongly suggested in Fig. 12.

school, together with the necessary confinement and restraint, it is obvious that the school life of the child becomes a heavy burden, which rests upon the young shoulders with a continuity almost unbroken—certainly for certain temperaments and for ambitious or studious children—for about ten hours daily. It is not surprising, therefore, that so many children fail in general health, or that their eyes should give way under the strain of so many hours of work, a very large percentage of which is done at a near-point, as in reading and writing. Even should it be at the cost of less rapid progress in their educational work, I am convinced that a decided reform in this respect is much needed. It is probable, however, that no loss would be sustained, since the freedom from restraint and the opportunity for exercise in the open air and the earlier hour for bed would add efficiency to the work performed in the school-room. It is an unmixed evil to require a tired, drowsy, and anxious child to work over books in the close atmosphere of the family room until overcome by exhaustion. An evening passed in this manner must be followed by restless sleep, disturbed by dreams, instead of the calm slumber so natural to the healthy child. Wise parents are often able to modify these harmful conditions in a measure; but it is nevertheless true that in numberless cases the comfort of an entire family, and especially of the self-sacrificing mother, is destroyed night after night by the preparation of the children's lessons at home. It would seem reasonable to contend that the five or six hours daily devoted to the sessions of the school from the age of six or eight years to that of sixteen or eighteen should be sufficient to prepare the young student either for college or for business, without infringing so seriously upon the home life of the child and employing in study time which should be devoted to recreation.

*Evils of the Reading Habit.*—In this connection allusion must be made to the almost universal habit of reading. Interesting books and periodicals expressly prepared by skilful authors for the instruction and amusement of the young afford constant temptation to the use of the eyes in reading, which is often allowed or encouraged by parents at hours when their children should be sleeping. There can be no reasonable doubt that this reading habit is an important factor in producing injury to eyes which would without it pass safely through the strain imposed by the schools.

*Necessity for a Break in the Continuity of Work.*—Much might be said here regarding investigations which have been made into the physiological limit of time in which useful intellectual work can be done. This would appear more appropriately, however, in considering the general subject of school hygiene. All investigation points to the need for frequent intervals of rest. What is true of the brain is also eminently true of the eyes. Since the strain upon the eyes is greatest at near-work, it should be so arranged that the blackboard and wall-map exercises, oral instruction, lectures, etc., should frequently interrupt the studies which require close application in reading and writing, and that the school session should be

broken by short recesses passed in the open air, or by gymnastic exercises, marching, etc. In one of our city schools, at a recent visit, I found the entire school, consisting of over thirteen hundred pupils, marching and countermarching through the rooms and corridors, and on inquiry found that this was done twice daily,—in the middle of the morning and afternoon sessions,—each class being marched to the urinals and back again to their respective class-rooms, a device which not only saved much otherwise unavoidable annoyance and interruption during the session of the school, but also afforded a break in the continuity of work.

*Term Examinations.*—Another evil to be deplored is the system of term examinations in vogue in the schools. In order to determine the class standing of the pupils, midwinter and June examinations are held. Since promotion is made contingent upon the successful passing of the examination, it follows that for a few weeks before the coming trial both teacher and pupil are prompted to extraordinary diligence in reviewing the work of the term. This requires upon the part of the children a considerable increase in the hours of study and a corresponding trespass upon the time which should be devoted to recreation or sleep. While it is doubtless true that this protracted strain falls heavily upon the eyes and general health of all the pupils, I have had abundant opportunity to witness its especially baneful influence upon weak-eyed children. I have many times observed almost sudden relapses of choroidal disease with an increase in refraction brought about in the eyes of patients after this spasmodic exertion in preparing for examination, and this, too, after the steady work of the term had been accomplished without harm. In view of the great strain upon the physical endurance of the children imposed by these periodical examinations, it is probable that better results, even from the stand-point of the educator, would be reached by frequent unexpected reviews, by more careful teaching throughout the term, and by allowing the class standing and fitness for promotion to be determined by the marks for recitation and by the teacher's estimate of the pupil based upon knowledge gained by daily contact.

It does not fall within the province of the physician to sit in judgment upon the relative merits of the educational methods adopted in our schools, except so far as they may affect the physical well-being of the pupils; but where injury is liable to occur as a result of the methods employed, I submit that such methods should be either abandoned or so modified as to remove their injurious effects.

#### THE ARCHITECTURE OF SCHOOL BUILDINGS.

Another phase of school hygiene, separated from the educational methods of the school-room, but of vast importance both for the general health of the pupils and for the safe and comfortable use of the eyes, is the question of school-house architecture.

*Location.*—In the construction of school buildings the first point for

consideration is a suitable and healthful location. In cities it is not always practicable to take into account the nature of the soil upon which the school building is to be reared, nor is it so important as in rural districts, since care is usually exercised to secure artificial drainage and sanitary protection. In the country, however, it is important to choose a well-drained location, if possible, without a clay subsoil and remote from malarial or other injurious environments. In cities the school buildings should not be situated on narrow streets, or amid high surrounding buildings which shut out the light and prevent the free circulation of air. The locality should always be remote from manufactories, markets, etc., in order to avoid their distracting noise and confusion and their exhalations, smoke, and dust. Where it is possible, ample ground should be secured for sports in the open air during intermissions of the school session. Where this is not possible from any cause, the building should be constructed with a flat roof, which in fair weather can be used as a play-ground, and with large, well-lighted, and dry cellars, which can be used for purposes of recreation on stormy days. In the construction of the school building provision should always be made for a well-lighted and well-ventilated cellar under the entire structure, the floor of which should be not more than three feet below the surface of the ground, and its ceiling not less than eight feet from the floor, which allows space above ground for windows. The cellar walls should be constructed with a water table, and inside both walls and floor should be thoroughly cemented in order to exclude all dampness from the surrounding soil, while the ceiling should be plastered in the most thorough manner. The windows should be ample in size and sufficient in number to secure good lighting and draughts of air by opening them in dry weather. In the newer school-houses in Philadelphia this plan has been adopted, and in one of them, the Francis M. Drexel School, I found a large, dry, and well warmed and lighted cellar devoted to the purposes of recreation on rainy days. In one part of it a large quantity of dry, clean sand had been placed, and the primary school children were pleasantly amusing themselves with bucket and shovel, as at the sea-shore. On the surrounding wall had been painted a representation of the surf.

As to the general plan or detail of construction, only those points which interest us from the stand-point of the hygiene of vision will be mentioned. Sufficient light, properly admitted to the school-rooms, is of essential importance, and, therefore, should be first considered in the architectural plan for every school-house. The best plan for large buildings is that which provides for their construction around a large, open, central square or quadrangle, one or more sides of which can be utilized, the other sides of the square being covered as the growing demands of the neighborhood may require. The sides of the building next to the central square should be devoted to corridors, teachers' rooms, the executive department of the building, water-closets, fire-escapes, etc., while in the square should be placed a smoke-stack, heating apparatus, and machinery for forced ventila-

tion. The outer side of the structure can then be devoted exclusively to the school-rooms. The further details of this general scheme are shown in the ground-plan (Fig. 13) kindly furnished me by Mr. Joseph D. Austin, the architect of the Philadelphia School Board, and its general features are explained in his accompanying letter, which through his courtesy I am permitted to publish.

“OFFICE OF THE ARCHITECT AND SUPERVISOR OF THE BOARD OF PUBLIC EDUCATION.

“PHILADELPHIA, December 12, 1893.

“DEAR SIR,—Agreeably to promise, I enclose herewith a plan which, after years of experimenting, appears best adapted to school purposes, under the system of teaching adopted in this city.

“The chief merit of this plan of building is in economy of room. The sliding doors separating the class-rooms, when pushed into the pockets provided for their reception, afford a large hall for assembling purposes, which can be again converted into separate class-rooms, each heated, ventilated, and lighted as well as if designed separately.

“Another merit of the plan is the facility with which the size of the building can be increased as the growth of the district may require.

“The wing rooms in very many cases are attached several years after the main building is finished, and this can be done without interfering with the sessions of the school.

“Most of the buildings are of necessity three stories in height. This, under the law, requires fire-escape stairways. We endeavor to make these of such easy access and so easy of themselves that they can be used daily in preference to the internal stairways.

“The steps and risers are of slate enclosed in brick partitions, but open to the weather at each landing, so that there can be no possibility of an accumulation of smoke in the event of a fire in the building.

“The class-rooms are of uniform size, twenty-four by thirty-two feet, with ceilings thirteen feet high,—nine thousand nine hundred and eighty-four cubic feet,—designed to accommodate forty-five pupils, about two hundred and twenty-two cubic feet for each (good authorities recommend two hundred and fifty cubic feet).

“In an eighteen-division school building constructed on this plan, two-thirds of the class-rooms are lighted from two sides [front and rear—S. D. R.], the window surface being equal to one-fifth of the floor surface; while the inner or side rooms are lighted from one side only, the window surface being equal to only one-ninth of the floor surface.

“I think in a perfect school-room the window surface should not be less than one-sixth of the floor surface.

“You will notice a coat-room attached to each class-room, of sufficient size to accommodate hats and wraps of the forty-five pupils in the class. These rooms are ventilated by transoms into the hall-ways, and cannot contaminate the air of the class-room.

“In reference to seating arrangements, we have adopted the combination seat and desk, arranged to have the light either on the left of the pupil or on the left and rear.

“We find the following table of heights and sizes best adapted to our three grades,—Grammar, Secondary, and Primary,—with two sizes for each grade.

Length of Top.	Height to Lower Part of Top.	Height to Front of Seat.
Grammar, double, 42 inches . . . . .	27 $\frac{1}{4}$ to 28 inches.	15 $\frac{3}{4}$ to 16 $\frac{1}{4}$ inches.
Grammar, single, 24 inches . . . . .	27 $\frac{1}{4}$ to 28 inches.	15 $\frac{3}{4}$ to 16 $\frac{1}{4}$ inches.
Secondary, double, 40 inches . . . . .	25 to 26 $\frac{1}{2}$ inches.	13 $\frac{1}{4}$ to 15 inches.
Secondary, single, 21 to 22 inches . . . . .	25 to 26 $\frac{1}{2}$ inches.	13 $\frac{1}{4}$ to 15 inches.
Primary, double, 38 inches . . . . .	21 $\frac{1}{4}$ to 23 $\frac{1}{4}$ inches.	11 $\frac{1}{2}$ to 13 $\frac{1}{2}$ inches.
Primary, single, 19 to 20 inches . . . . .	21 $\frac{1}{4}$ to 23 $\frac{1}{4}$ inches.	11 $\frac{1}{2}$ to 13 $\frac{1}{2}$ inches.



“Blackboard surface is always arranged to the front and right of the pupils, and never between windows.

“The rooms are heated with steam, direct and indirect system combined: indirect for the purpose of introducing fresh warmed air into the room, and the direct system to supplement the indirect in very exposed positions.

“We aim to inject into the room about nine hundred cubic feet of air per minute, or about twenty cubic feet for each pupil.

“Ventilation is effected at the floor and ceiling line by register openings into the large stacks, where an artificial current is established either by coils of pipe or exhaust fans.

“Very truly yours,

(Signed) “Jos. D. AUSTIN.”

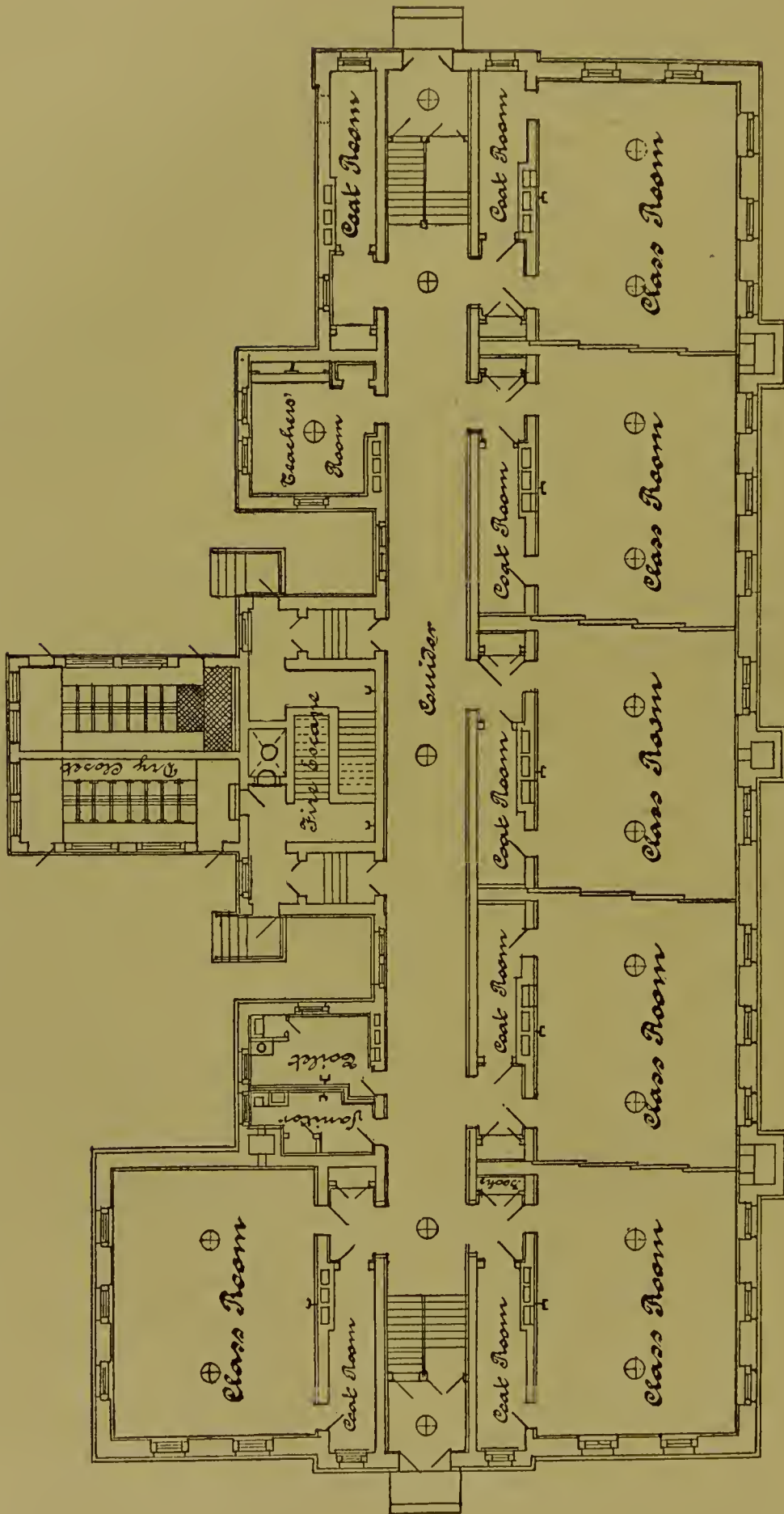
Fig. 13 is the floor-plan furnished by Mr. Austin, and Figs. 14 and 15 are views of the completed building and of the interior of the school-rooms. The blackboard partitions are run back into their pockets, so that the series of school-rooms along the eastern side of the building are thrown into one large assembly-room.

#### THE LIGHTING OF SCHOOL-ROOMS.

Among the many advantages secured by this admirable method of construction is that it affords opportunity to secure sufficient and proper lighting of all the school-rooms, which are arranged in succession around the outer side of the quadrangle. So far as the hygiene of vision is concerned, this is of primary importance, since without adequate light, properly admitted to the room, the eyes cannot be placed under favorable conditions for the performance of their important function. The importance of sufficient light cannot be too strongly urged. Two points are of especial importance: *first*, the quantity, and, *second*, the direction, of the light. Neither of these is likely to be secured unless they are placed before the architect as fundamental requirements in the construction of school buildings.

*Quantity of Light.*—It is obvious that no plan of construction can atone for the too close proximity of surrounding structures which shut out the light or reflect it injuriously from their opposing walls or windows. The rule given by Javal is a good one,—viz., that the distance of surrounding structures should be twice their height. Fuchs places the angular measurement of near buildings at from twenty to twenty-five degrees. With this rule strictly followed, the sky-light will fall directly upon the desk of every pupil in any properly proportioned school-room. As to the quantity of light, Cohn very properly maintains that there cannot be too much, and Javal insists that every portion of the room should be so flooded with light that the darkest place will have sufficient illumination on a dark day. Numerous and ingenious photometers have been devised to determine the actual amount of light in any given room. A sufficient test, however, is the ability of a normal or optically corrected eye to read D. = .50, or diamond type, at one-third of a metre (twelve inches) readily, or to distinguish No. VI. on a card of standard test-letters at six metres

FIG. 13.



Ground-plan of a Philadelphia school-house.

FIG. 14.



Francis M. Drexel School, Philadelphia.

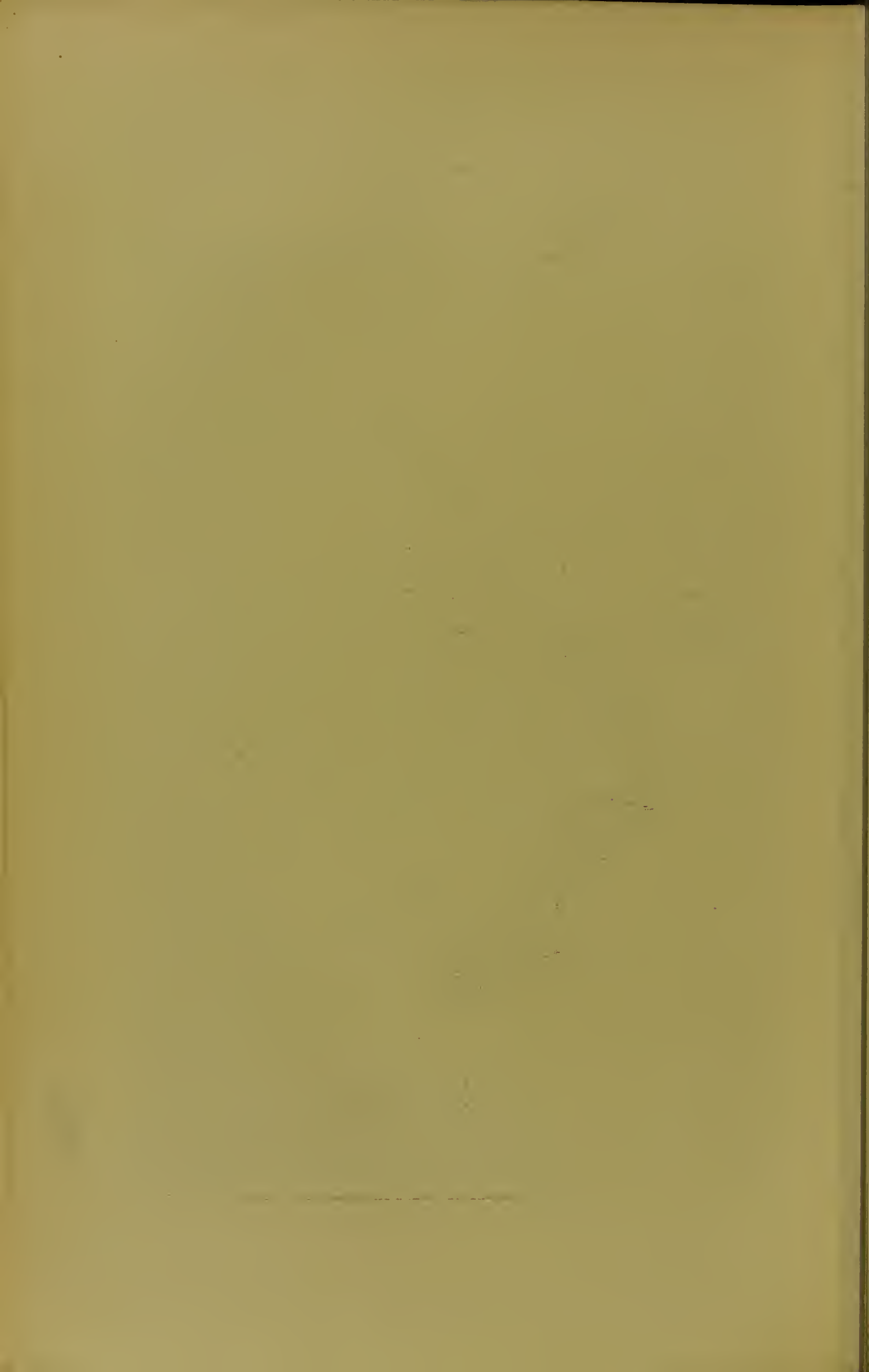


FIG. 15.



Interior suite of rooms in Francis M. Drexel School (Fig. 14), thrown into a general assembly room.



(twenty feet). The importance of sufficient light is made manifest by any attempt to read in the twilight or in a dimly lighted room. The tendency is to hold the page too near the eyes, in order to secure a larger retinal image, or possibly to take advantage of the law that the illumination diminishes as the square of the distance. The strain upon the accommodation and convergence brought about by this abnormal near-point soon causes undue congestion of the eyeball and surrounding tissues, and thus leads to increased intra-ocular tension. This turgescence of the ocular membranes is still further favored by the disturbance of the circulation and respiration brought about by the faulty position of the body which is also usually assumed when the book is held too near the face. The great harm which may result from insufficiently lighted rooms I saw illustrated in a school of eighty children. The light was so poor that on a bright afternoon I could not read diamond type in any part of the room. The average age of the children was about nine years, and yet I did not find a single healthy eye in the class. They were, without exception, unduly sensitive to light, had turgid chorioids, and suffered from headache and other nervous symptoms in varying degrees. Many were suffering from cramp of the accommodation, and, although very few had as yet developed a static myopia, that this would have been the result in many, had their work been continued under such unfavorable conditions, cannot be doubted, since many of them had V. less than  $\frac{6}{VI}$ , and the accommodation cramp simulated near-sight. Cohn found in 1865 more myopia among the elementary schools where the light was shut out by contiguous buildings, and especially in those classes which were located on the ground-floors, for here the light was still more deficient than in the higher rooms.

It is the duty of the architect, therefore, to secure in his plan all the window surface possible consistent with safety of construction. The relation between the actual surface of glass in the windows and the floor space should be subject to definite requirement, below which it should never be allowed to fall. In the Prussian model school-room exhibited at the Paris Exhibition in 1867, Professor Cohn found 16.7 square inches of glass to each square foot of floor space, and in the American model 32.2 inches, but he proposes that there should be at least 30 square inches to every square foot, or one square foot of glass for every five square feet of floor space. In the Vienna Exhibition of 1873, in seven exhibits this percentage of glass to floor space was not reached in five and was exceeded in two. In the Swedish school it was 32, and in the model of the Franklin School at Washington 52.8. As demonstrating the growing recognition of the importance of sufficient light, he found at the Paris Exhibition in 1878, in the Ferrand School-House, that the window space and the floor space were approximately equal.<sup>1</sup> It is obvious that the proper ratio of glass to floor space is modified by the environments of the building, by the elevation of

---

<sup>1</sup> Hygiene of the Eye.

the school-room above the ground, and by the color of the walls both of surrounding structures and of the room itself. The ratio should of necessity be a more liberal one for the rooms situated upon the ground-floor, unless the building is remote from obstructions.

Undue regard to cost of construction or to the external appearance of the buildings should not control the architect as to the amount of surface devoted to windows and the intervening wall space. In every school building the latter should be sufficient only to insure the stability of the structure and to supply accommodation for ventilation, heat- and dust-flues, etc.

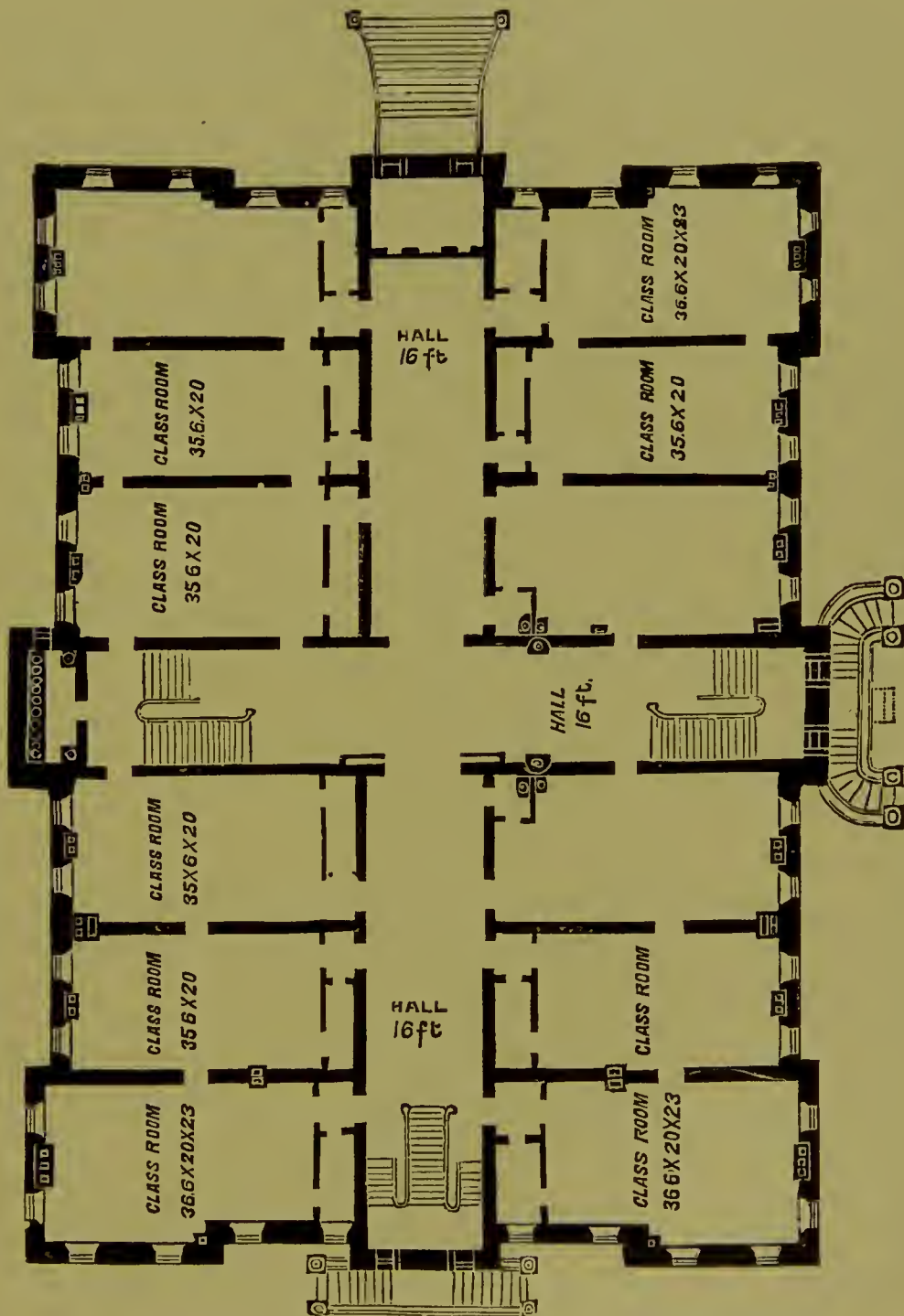
The quantity of light is greatly modified by the color of the walls in the school-room. The red end of the spectrum should never be chosen in the painting or decorating of school-rooms, as much light is lost by the employment of these colors. The lighter or more delicate shades of yellow, green, blue, or light grays should be chosen. The large percentage of wall space often occupied by blackboards causes much loss of light. They are, of course, a practical necessity in every school-room, but when not in use they can be covered by roller shades of the same color as those used at the windows or on the walls. For the same reason light-colored woods should be selected for the school furniture and for the wood-work used in the construction of the building. The value of the lighter shades of color in the decoration of rooms as a means of saving light I have found forcibly demonstrated in different rooms of my own house. In one room the prevailing tints are medium shades of terra-cotta, with dark frieze and hangings and walnut bookcases. In a second the tints used in the decoration are faint yellow, with hangings in harmonious shades of color, and light furnishings. In the first, D. = .50 could be read distinctly at one-third of a metre, no farther than two metres, from a single sixteen-candle incandescent electric lamp; while in the second room, with its lighter shades of color, the same type, under exactly similar conditions in all other respects than the color used in the decoration, could be read with equal facility at three and a half metres from the lamp. The quantity of light will also vary greatly on different days and during different parts of the same day. Thus, rooms having an eastern or a southern exposure will be better lighted during the morning hours. The window space should therefore be estimated for the least favorable conditions, so that even on dark days or during the least favorable hours of the day the light shall be adequate. There should never be less than one square foot of glass in the windows to five square feet of floor in the school-room. This is often inadequate in the dark weather which prevails for so large a percentage of the time during the winter months in this climate, and for school-houses badly situated as to surrounding buildings. Indeed, I think it should always be exceeded for rooms with a northern exposure and where the windows are situated in but one end of a long, narrow room (Fig. 16).

The architectural arrangement should be such that the windows will



be placed at the side of the room rather than at one end. The disadvantage of the latter relation is exemplified in the floor-plan of one of the older school buildings in Philadelphia, shown in Fig. 16. The ground-plan is here radically and hopelessly wrong, except for the corner rooms, which

FIG. 16.



A defective ground-plan.

are well lighted, while the remote ends of the inner rooms are so dark that even on bright days the light is insufficient. This plan should be compared with the admirable later plan introduced by Mr. Austin (Fig. 13), or with the ideal plan suggested on page 393 (Fig. 19).

Sky-lighting has been recommended as preferable to all other methods. I have seen examples of this only in weaving establishments and in the anatomical amphitheatres and operating-rooms in hospitals and medical colleges. In large school buildings it is obvious that the sky-light is possible only for the upper floor, just where it is required least. The great heat produced in such rooms during the summer months, and the difficulty of heating them in cold weather, are, however, insuperable objections to this form of lighting.

*Direction of Light.*—Another point of great practical importance is the direction from which the light falls upon the desk. In the first place, the desks should never be so arranged that the pupils shall face the window. The harmful effect of such seating is unmistakable, as I have had abundant opportunity to observe. In 1878 I found many classes in the Philadelphia schools so seated, and in many of the rooms the blackboards occupied the wall surface between the windows. The injurious results of this arrangement had been recognized by the School Board, and the class seating was being rapidly reversed. This, of course, made it necessary for the teachers to face the window, and as a result I was soon greeted with a chorus of complaints because of their headaches and troublesome eyes, dating back to the change in the seating of their school-rooms. Thus incidentally was furnished a practical demonstration of the injurious effects of working with a light falling directly upon the unprotected eyes while reading or writing. From the stand-point of the ophthalmologist, the ideal school-room is lighted only from the left side, or the left and the rear, of the pupils. In every properly constructed school-house lighting from two opposite sides should be avoided under all ordinary circumstances, since it occasions cross-lights and perverse shadows. In localities where the light is obstructed by tall trees or contiguous structures, or where the architectural design of the building permits, the light in the room may be increased by windows on the right side also, since this is better than a too dark room; but they should be placed high, the bottom of the window being not less than three metres from the floor, or the lower sash should be habitually shaded by board shutters or opaque shades. The added illumination of the ceiling thus secured will increase the diffused light in the room, and in hot weather these windows will afford additional ventilation; but even under this arrangement the sky-light will fall from the right side upon the desks most remote from the windows and cause annoying shadows and cross-lights. Where additional light is necessary, better results can be reached by placing at the lower half of the windows, on the left, a second outer sash, glazed with fluted glass, which can be dropped outward at an angle of thirty-five or forty degrees and will then act as a reflector and throw the sky-light on the desks of the pupils. This expedient I have seen adopted to increase the illumination in insufficiently lighted counting-rooms in mercantile houses where the windows open into deep wells formed by other parts of the large buildings, and in one instance I saw the lower rooms of a church lighted in this way.

FIG. 17.



School-room in which the light is admitted from the right-hand side. Old form of seat and desk arranged with plus distance.



FIG. 18.



School-room lighted from the left side and the rear; window surface one-fifth of the floor surface. Suitable desk and seat, arranged with minus distance.



Where there are high contiguous structures, their harmful influence in excluding the light may in some measure be obviated by painting their walls in some light color.

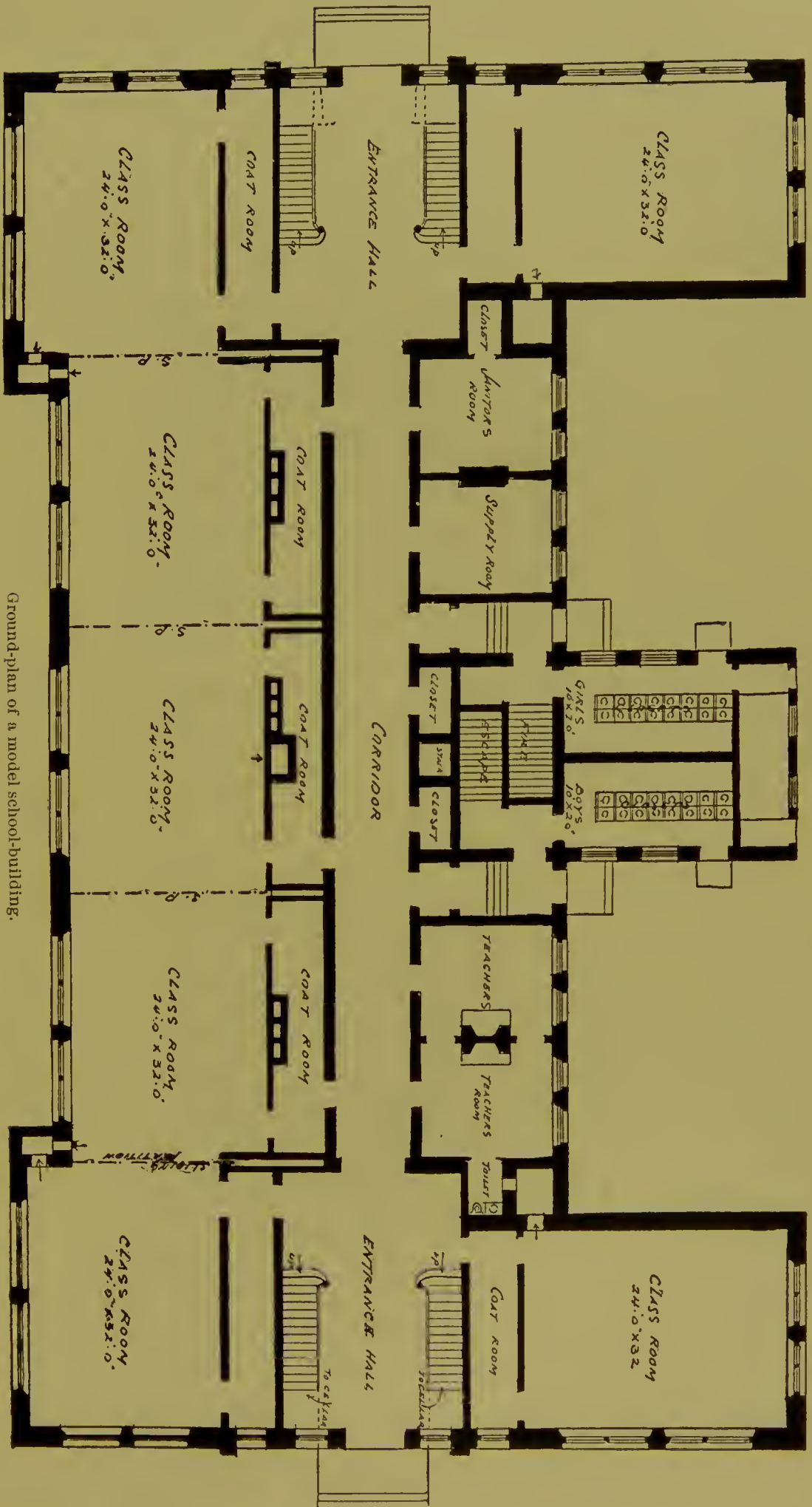
The unfortunate effect of the perverse lighting afforded by windows on the right side only is well illustrated by the photograph taken for me by Mr. Sword and reproduced in Fig. 17. The uncouth and irregular postures of the young children in the class are occasioned in large part by the struggle to avoid the shadow of the hand, which falls directly at the point of observation. There is scarcely a member of the class in a comfortable or natural position. As we shall observe later, this is in part due to the improper arrangement of the desk and seat, but the injurious effect of the right side light is not open to question. The class shown in the photograph Fig. 18 occupied a southeast corner room on the second floor in the Francis M. Drexel School (Fig. 15). The windows are on the left and rear of the class, and the proportion of window surface to floor surface is as one to five. The modern single desk and seat were used throughout this almost perfect school building. The natural pose of almost every pupil, and the air of comfort which pervades the class of girls at their work, are unmistakable and very gratifying, and afford a vivid contrast to the unfortunate situation of the children in Fig. 17. When the picture was taken, the pupils were simply requested to write a sentence dictated by their teacher, and no instruction was given as to the posture they should assume. It will be observed that in the northwest corner of the room several of the pupils have placed their paper in such a position as to secure light from the rear window also. In the same building, on a cloudy day, in the side rooms, where the window space is but one-ninth of the floor space, the light was not sufficient on the side of the room remote from the windows, but was found adequate on a clear day. After a careful study of the practical results reached in this and other buildings constructed on essentially the same plan, but with various modifications, I placed in the hands of an architect, Mr. J. M. Huston, a ground-plan in outline much the same as Mr. Austin's, with the dimensions of each room, window and wall space calculated to meet the ideal requirements of a school-room, together with many suggestions as to details of construction. He was requested to furnish the floor-plan and a sketch of the completed building. The result is shown in Figs. 19, 20, and 21. In unilateral lighting the lower sill of the windows should not be less than one metre from the floor, so that the light shall enter well above the heads of the pupils while seated at the desks, and the tops of the windows should extend to the ceiling. The wall space on the left side of the room should be as small as architectural requirements will admit, and the sash and centre of supports so constructed as to intercept the light to a minimum degree. We see examples of the possibilities in this direction in our great shop-windows. The windows should be grouped, occupying the centre space of the left-hand side of the room, and the jambs bevelled in order to avoid shadows. These conditions of lighting determine largely

the dimensions and form of the school-room. A high ceiling will permit higher windows, and therefore a broader floor space, and still allow direct sky-light to fall upon the desks farthest removed from the window. In the new school-houses in Philadelphia the windows are constructed so that a section of the upper sash is hinged and can be drawn inward at the top, thus giving opportunity for ventilation without direct draughts of air upon the heads of the children, since the incoming current will be directed first along the ceiling. This small upper sash is glazed with lightly ground glass. The following dimensions are given as a working basis. Any considerable departure from the figures given will introduce less favorable conditions. (Fig. 19.)

	Feet.
Height of ceiling . . . . .	15
Length of room . . . . .	32
Width of room . . . . .	24
Pier or blank wall, rear of room . . . . .	4
Pier or blank wall, front of room . . . . .	4
Space allotted to group of windows . . . . .	24
Window-sill from floor (bevelled) . . . . .	3
Top of window from floor . . . . .	14
Dimensions of window: <i>height</i> , 11 feet; <i>breadth</i> . . . . .	24
(Window-casing bevelled to six inches from ceiling.)	

Disregarding the sash and narrow piers or jambs introduced in the construction of the group of windows, there would be for the centre rooms two hundred and sixty-four square feet of glass to seven hundred and sixty-eight square feet of floor surface, or 1 of glass to 2.9 of floor surface; while for the corner rooms the proportion would be approximately as 1 to 1.5. The capacity of the room would be eleven thousand five hundred and twenty cubic feet, or two hundred and fifty-six cubic feet of air space for each of forty-five pupils. This scheme was presented to Mr. Austin for criticism in the light of his large experience in school-house construction, and met with his approval in every particular, as possessing added advantages in all respects. "The cost of construction," he remarked, "would be slightly greater, and girders should be placed under the broad windows for increased support, and the intervening walls should be heavier." Fig. 14 is a cut of one of the Philadelphia school buildings which illustrate the possibility of securing beauty of architectural outline and at the same time meeting all the hygienic requirements of the school-room. Fig. 15 is an interior view, with sliding partitions which contain the blackboards driven home into the pockets provided for their reception, thus throwing the succession of school-rooms into one large hall for general exercises. The ground-plan of this building is the same as the one furnished by Mr. Austin (Fig. 13). The plan constructed for me by Mr. Huston is presented in Figs. 19, 20, and 21, the latter being a detail of the window. In the floor-plan the broad window space and the narrow intervening wall are well shown. That such an arrangement of windows is susceptible of very





Ground-plan of a model school-building.

FIG. 19.

FIG. 20.

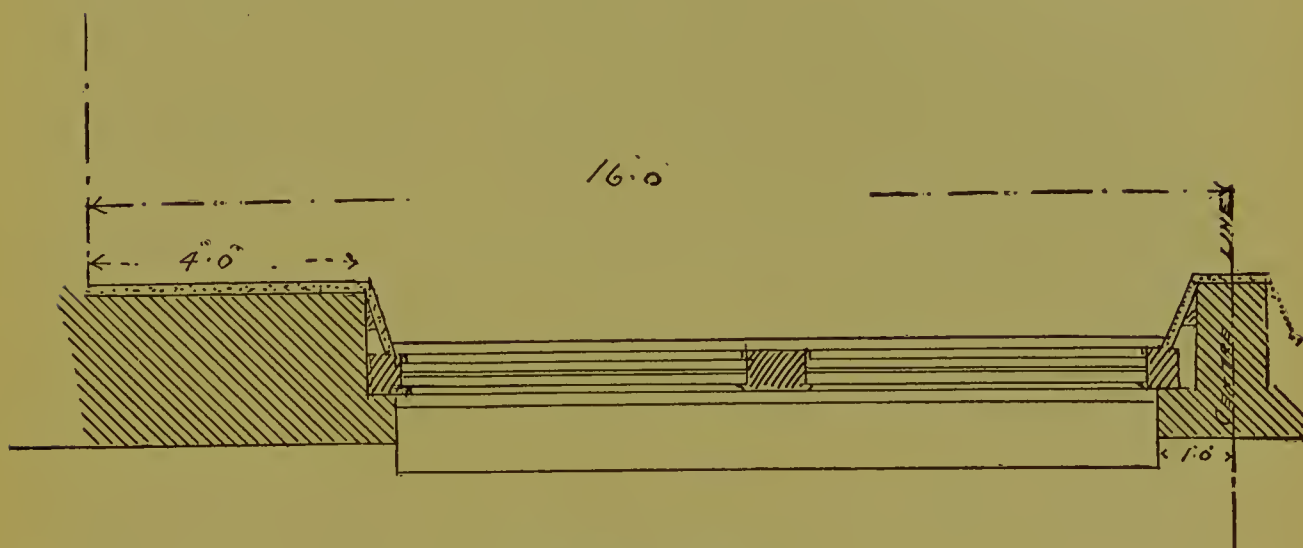


Model school-building. Roof-garden for sports and recreation.

effective architectural treatment is obvious from the beautiful design suggested by Mr. Huston. In an accompanying letter he suggests "a light color for the building, red granite base, yellow brick and light stone or white terra-cotta trimmings, and Renaissance treatment in detail." The flat roof he regards as a departure in school building, and he has placed the national flag at the four corners, because he thinks it should fly from all public school buildings. The flat roof I had suggested as a suitable play-ground for the children, since with proper fencing it could be made entirely safe, and in crowded districts of the city it is not always possible to secure sufficient ground for the purpose.

While the material used in construction as suggested by Mr. Huston may be too costly for public school purposes, the beautiful effect of such

FIG. 21.



Half-section of a window.

treatment is beyond question. From the point of view of hygiene, a less ambitious structure as to materials employed would, however, be equally effective.

*Artificial Illumination.*—In such a structure as has been suggested, properly located, artificial illumination need not be considered; but in old or faulty school-rooms it often becomes a necessity, and is greatly to be preferred to insufficient light. For this purpose the incandescent electric lamp is the best. A sufficient number of sixteen-candle lamps should be arranged in a group in the centre of the ceiling, with a large porcelain reflector above them, and others distributed at intervals of a metre or less along the cornice of the room, all being so arranged that a part or the entire number of lamps may be turned on or off, as required, by conveniently placed switches. The lamps should be made of lightly ground glass, so that the glowing carbon wire may be concealed, the white globe itself becoming the source of illumination for the room. Another excellent arrangement is the distribution of a sufficient number of lamps at regular intervals over the ceiling. These guarded lamps placed on the

ceiling do not cause dazzling, and when properly distributed need no other shading and do not cast shadows, as I have been at pains to verify. In a room five metres high, ten metres long, and eight metres wide, containing, therefore, four hundred cubic metres, twenty-five sixteen-candle incandescent lamps would furnish one candle for each cubic metre of space in the room. In a room with *one and a half* candles to each cubic metre, all distributed from a central chandelier, I was able to read D. = .50 (diamond type) readily at one-third of a metre in any part of the room, with the lamps as a sole source of illumination. Therefore, in a room of the dimensions suggested, designed for forty-five pupils, twenty-five lamps would furnish approximately *nine* candles for each pupil, and, added to the daylight, even on the darkest days would afford ample illumination in any part of the school-room. The electric lamp has the great advantage of being readily turned on when required and off again when not needed, and does not interfere with the air of the room by consuming the oxygen or vitiate it by the products of combustion.

*Exposure.*—There is difference of opinion as to the best exposure with reference to the cardinal points. Dr. William F. Norris decides, where a choice is possible, in favor of a northern exposure for our climate, as giving a more uniform light and avoiding the direct glare of the sun through the windows, and as being less hot in the summer. Cohn, on the other hand, favors without qualification a southern and eastern exposure. In a warm climate, or in localities like Denver, Colorado, where the days of bright, uninterrupted sunshine outnumber the cloudy days, a northern exposure is probably desirable. In Philadelphia, dentists, photographers, and draughtsmen prefer a northern light because of its greater uniformity. South rooms, even on bright days, are subject to a constantly varying light, as the fleeting clouds now and again cast their shadows over the landscape. My own preference is, nevertheless, for rooms having an eastern, southern, and western exposure, so that at some time during each day they shall be bathed in a flood of sunshine. In the school-house plans given above I would, therefore, where it is possible, place the corridor east and west, the side rooms of the plan being to the south, and the wings facing respectively east and west. The greater cheerfulness and warmth of sun-bathed rooms, and their comparative healthfulness, are not open to question. I inquired of the principal of one of the large Philadelphia schools whether she preferred the south or the north rooms in the building. She replied, "I like the north rooms for the drawing classes, but prefer the south rooms for general school purposes, because the children are always brighter, more cheerful and orderly, in them." The building faced east, with north and south wings, so that she had opportunity for daily comparison. It should be remembered also that, other things being equal, the light is better on the south side. Cohn demonstrated this to his satisfaction at the Zwinger School in Breslau, where his reading tests at four feet could not be distinguished in a room facing north, but were readily made out in a south

room, all other conditions being the same. The superiority of a south light I also have been at pains to verify. While this may be of but little importance in bright weather, the light then being sufficient in any case, it is of much significance on cloudy days.

The increased heat in sun-bathed rooms during the hot months finds ample compensation in the added warmth and cheerfulness in the winter, while in the summer, it should be remembered, in this climate the prevailing winds are from the southwest, and may be admitted, when found desirable, through the open windows and corridors. It is true also for the United States that the school vacations begin in the latter part of June and extend into September, so that the schools are closed during the hottest weather. That it is objectionable from the stand-point of the hygiene of vision to permit the direct rays of sunlight to fall upon the desks in the school-room is true; but this can be controlled by a judicious arrangement of shades. These should be of some neutral tint. A linen shade known in the trade as the "Holland shade," of a light gray or straw-yellow or cream color, is suitable for this purpose. I prefer the cream-tinted shade. The shades should be mounted on stop-spring rollers, two at each window, one at the top, the other at the bottom, and each long enough to cover the whole length of the window. The lower shade can be drawn upward the entire length of the window by means of a cord running through a check-pulley at the top and thus held in any position that may be desired. The top shade can be drawn downward and also caused to screen the entire window, the two forming a double screen, if needful, or they may be made to follow each other upward and downward, shading any part or parts which it may be desirable to screen. When not in use, they roll up out of the way, and do not intercept the light, as would be the case if they were hung in the middle of the sash.

#### PART IV.—SCHOOL FURNITURE.

Among the many reforms in school hygiene, none are more deserving of mention than those pertaining to school furniture. The literature on the subject is already voluminous. No sooner was the increasing percentage of myopia in the schools made manifest by the extensive statistics which were collated, than it was sought to fasten the responsibility for the increase on the faulty construction of the school desk and seat. Prior to the work of Cohn in Breslau, orthopædic surgeons had placed the responsibility for spinal curvature upon the faulty relation which was found to exist between the seat and the desk. To one of our own countrymen, Henry Barnard, is due the credit of having been the first to attract attention to the serious defects in the seating of our school-rooms. As early as 1860 he pointed out the great importance of the seat being placed close up to the desk, in order that the harmful posture of reaching forward, which was made necessary by what afterwards came to be known

as the plus distance of the seat, might be avoided. It was reserved, however, for Fahrner, of Zurich,<sup>1</sup> and for Hermann Meyer<sup>2</sup> to point out the mechanical problems involved in faulty and correct postures in sitting, and thus to pave the way for much-needed reform in the construction of seat and desk. There is much cause for just condemnation of school authorities in the fact that, thirty years after the clear and convincing demonstrations made by these authors, thousands of school-children are still required to pass their school lives at desks with the old faults uncorrected.

No essential addition has been made to the teaching of Barnard, Fahrner, and Meyer. The principles involved in correct and faulty sitting, as taught by them, are simple and readily comprehended. To Meyer is due the credit of the anatomical demonstration. The figure on the next page (Fig. 22) is taken from Cohn after Meyer,<sup>3</sup> from whom also the following statement of the principles to be considered is condensed.

#### PRINCIPLES OF CORRECT AND FAULTY SITTING.

At the lower part of the pelvis are the two seat-bones, which are curved and rock easily backward and forward. A line drawn through these may be called the *seat-bones line* (*S*, Fig. 22). It is only when the line of gravity of the body falls perpendicularly upon the seat-bones line that the body can remain at rest in a sitting posture. Any movement which displaces the centre of gravity of the trunk, which is situated in front of the tenth chest vertebra (*P*, Fig. 22), must carry the line of gravity either in front of or behind the seat-bones line and make it necessary to seek a third point of support as a guard against the instability of the support now afforded by the seat-bones line. This third point may be either in front of or behind it, depending upon the direction of deviation from the position of equilibrium. (Fig. 22.) In the forward sitting posture it is obvious that this third point of support must be the front edge of the seat or some point between it and the seat-bones line. The farther forward it falls the more unstable is the support and the greater the exertion required by the muscles of the pelvis to maintain the unstable equilibrium. These muscles soon tire, and the trunk, obeying the law of gravity, falls forward if not upheld by some extraneous support. This is ordinarily furnished by the desk or table upon which the elbows or chest are allowed to rest. In a word, we simply prop ourselves up to prevent the trunk from falling forward after the muscles of the pelvis and back are tired out. In the backward sitting posture the third point of support is the coccyx, and the fall backward must be prevented by a back rest for the pelvis, which it is obvious from the foregoing should be centrally placed, and low enough to arrest the

---

<sup>1</sup> The Children and the School Desk, Zurich, 1865.

<sup>2</sup> Virchow's Archiv, 1867.

<sup>3</sup> Hygiene des Auges, 1892, p. 306.

pelvis as it rocks backward, not higher than the lower lumbar vertebra, if the body is to be supported in the upright sitting posture. These conditions are well illustrated in Fig. 22. It is plain from these mechanical considerations that the so-called plus horizontal distance of the school desk and seat—*i.e.*, where the front edge of the seat is so placed that a line dropped from the edge of the desk would fall some distance in front of the front edge of the seat—is a faulty and harmful arrangement of the school furniture.

In order to work at a desk so placed, the pupil is compelled to reach forward. To do this he perches himself on the front of the seat, while the feet are carried backward under it. The trunk falls forward and finds support upon the elbows, one or both of which rest upon the desk. If but one—the left—is used for support while the right hand is employed, as in

FIG. 22.

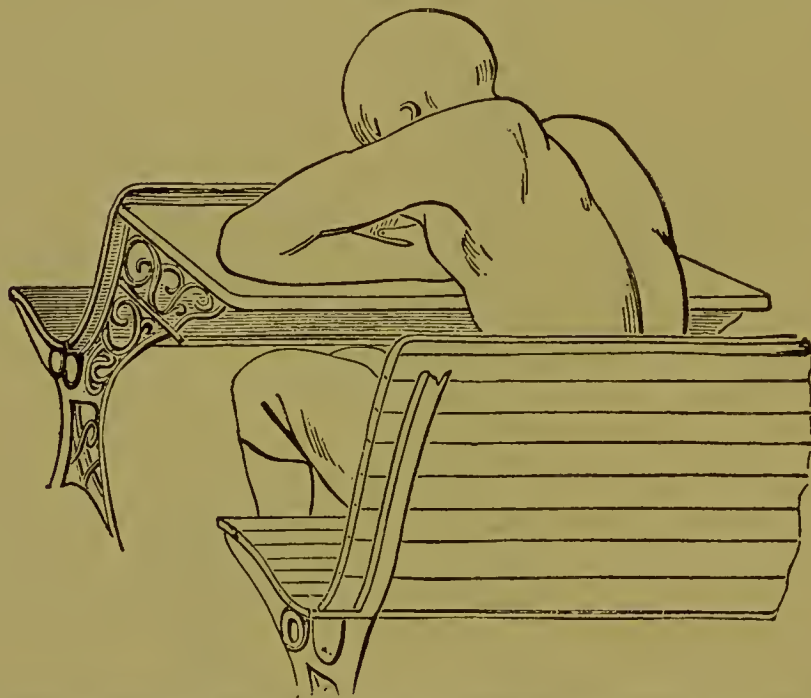


Illustrating the mechanics of correct and faulty postures in sitting (Cohn).

writing, the vertebral column is partially turned on its long axis and the entire trunk held in a distorted position which we may well believe is conducive to the production of spinal curvature in growing children. In this forward pose of the trunk the head is no longer supported by the spine, and must, therefore, be upheld by the muscles of the neck, which should be required only to balance the head. They soon tire, and the work then falls upon the muscles of the back, which in turn give up the task, and the head falls forward towards the work, while the trunk sags forward and downward between the shoulders, which are upheld by the arms, the elbows being supported by the desk. This faulty position is well illus-

trated in Fig. 23.<sup>1</sup> If the body is supported in this manner by the left arm alone, the head falls forward and is rotated to the right. The face is brought too near the page, and the left eye nearer than the right. The normal relation between the plane of the face and the work is thus disturbed, which, together with the abnormal near-point, adds greatly to the strain upon the accommodation and convergence. The practical value of this teaching can be readily demonstrated at pleasure by placing the chair in the respective positions already indicated. The abnormal position which must be assumed when the chair is placed at the plus horizontal distance will soon cause fatigue of the muscles of the back and pelvis, which speedily disappears when the seat is placed close up to the table, so that the upright sitting posture can be maintained.

FIG. 23.



Faulty position assumed in writing with the desk and seat too low and with plus horizontal distances.

#### THE SCHOOL DESK AND SEAT.

In these physiological and mechanical considerations are found the data which should guide us in the construction or selection and arrangement of the school desk and seat. Two points are of especial importance: first, the horizontal distance between desk and seat, as already pointed out; and, second, a proper vertical relation. If the seat is too high for the desk, the pupil must stoop over while at work, and thus render upright sitting impossible, the faulty posture being in most respects similar to that assumed when a too great horizontal distance is allowed between desk and seat. On the other hand, if the desk is too high, the arms cannot rest upon it without forcing the shoulders upward. The faulty position rendered

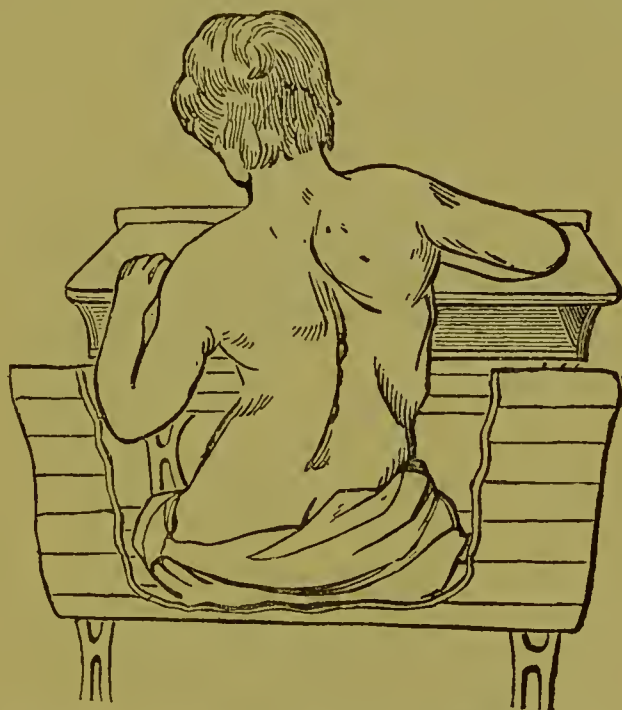
<sup>1</sup> Taken from catalogue of Hygienic School Furniture Company, New York.



necessary by this arrangement of the desk is well illustrated in Fig. 24, where the accompanying distortion of the spine is shown, as well as the too near approach of the eyes to the work.

The essential points to be observed in the proper seating of a school-room may be briefly stated as follows. The arrangement of seat and desk must be such that the child will find it easier to sit upright at his work than in any other position he can assume in the seat. To secure this the seat must be of such a height as to permit the soles of the feet to rest upon the floor. The measured distance will be the same as that from the sole to the inner bend of the knee. (Figs. 30 and 31.) The seat must be as wide as the thigh is long, measured from the inner bend of the knee to the back, and should be slightly concave to prevent sliding forward, but it should

FIG. 24.



Distortion of the trunk while working at a too high desk. (Loc. cit.)

not be inclined either backward or forward,—*i.e.*, it should be level. The front edge of the seat should be placed from one inch to two and a half inches under the inner edge of the desk. This is known as the minus distance. (A, Fig. 28.)

The top of the desk should be inclined towards the pupil,—*i.e.*, downward and backward ten degrees,—and must be low enough to permit the forearm of the pupil to rest lightly upon it without raising the shoulder while in the act of writing, but sufficiently high to avoid the necessity for stooping in order to reach it. The lower part of the back and the pelvis should be supported by a rest easily felt while sitting upright. (Fig. 25.) In order, however, to meet these requirements it is necessary to secure some definite relation between the size of the pupil and the size of the desk and seat. With this end in view, measurements of the different parts of

the body have been made in large numbers of children, ranging in age from six to fourteen years. Upon these measurements the school forms have been constructed in from three to six different sizes, to meet the necessities of different grades. It is obvious, however, that any desk rigidly constructed on the average measurements will work injustice to the extremes of size in the various grades. That this is true is incidentally shown in Fig. 17, where it is plain that the children in the class, although varying greatly in size, are nevertheless thrust into forms of the same dimensions, with the result of making some of them quite comfortable, while others are in uncomfortable postures similar to that shown in Fig. 24. Geissler and Uhlitzsch measured in the Freiberg district the height and relative length

FIG. 25.



Proper position in upright sitting, the pelvis supported by the forward curve in the back of the seat. (Loc. cit.)

of different parts of the body of twenty-one thousand one hundred and seventy-three children between the ages of six and fourteen years, for the purpose of finding the proper dimensions of school desks and seats. At the latter age the tallest boy measured one hundred and seventy-six centimetres, while the shortest measured but ninety-seven centimetres. Then, too, it is well known that in individuals of approximately the same height there will be considerable variation in the respective measurements of different parts of the body. It follows, therefore, that it is not sufficient to have the desks made of several different sizes to meet the requirements of the several grades, but that they should be so constructed as to be easily adjusted to meet the requirements of different individuals within the grade.

Mr. Priestley Smith has suggested four different sizes as sufficient, and divides the pupils according to height into four classes, advancing in each case by six inches, thus: three feet six inches to four feet, four feet to four feet six inches, four feet six inches to five feet, five feet to five feet six inches. The dimensions of the desk and seat are calculated to meet the needs for these four heights, and are set forth in the following table:<sup>1</sup>

TABLE V.  
HYGIENIC DESK (SMITH).

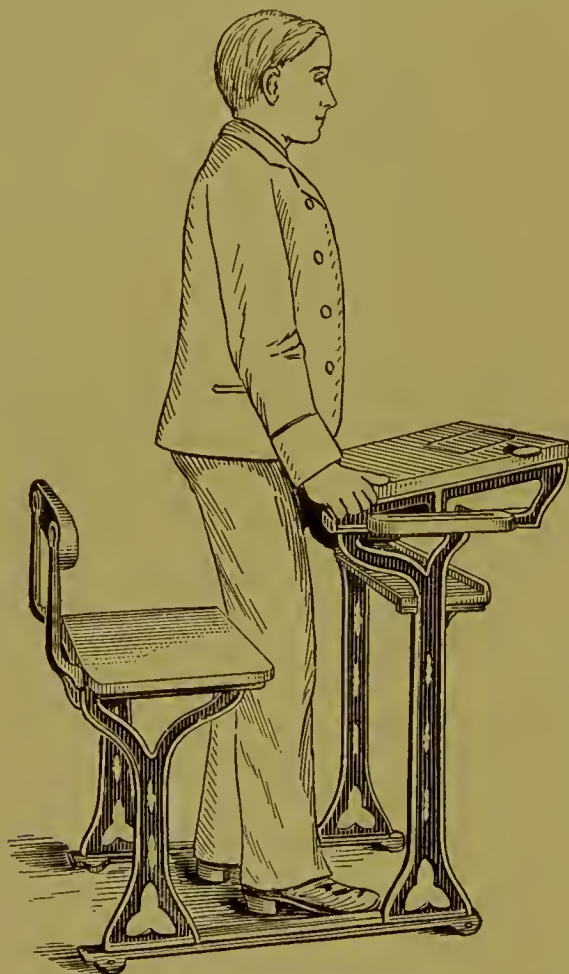
	No. 1.	No. 2.	No. 3.	No. 4.
Height of scholars . . . {	3 ft. 6 in.—4 ft. 107—122 cm.	4 ft.—4 ft. 6 in. 122—137 cm.	4 ft. 6 in.—5 ft. 137—152 cm.	5 ft.—5 ft. 6 in. 152—168 cm.
a. Height of seat from the floor. {	13 inches. 33 cm.	14½ inches. 37 cm.	16 inches. 41 cm.	18 inches. 46 cm.
b. Breadth of seat . . . {	10 inches. 25.5 cm.	11 inches. 28 cm.	12 inches. 30.5 cm.	13 inches. 33 cm.
c. Height from seat to edge of desk. { Height from seat to top of back. {	8 inches. 20 cm.	8¾ inches. 22 cm.	9½ inches. 24 cm.	10½ inches. 26.5 cm.
d. Overhang of desk (i.e. minus distance). {	1 inch. 2.5 cm.	1 inch. 2.5 cm.	1½ inches. 4 cm.	1½ inches. 4 cm.
e. Play of desk . . . . {	4½ inches. 11.5 cm.	4½ inches. 11.5 cm.	6 inches. 15 cm.	6 inches. 15 cm.
f. Breadth of desk (front to back). {	15 inches. 38 cm.	15 inches. 38 cm.	17 inches. 43 cm.	17 inches. 43 cm.

Fig. 26 sets forth with sufficient clearness the general plan of construction. One feature is noteworthy,—viz., the sliding top, which permits the pupil to stand in his place and thus overcome the inconvenience in this respect introduced by the minus horizontal distance. This otherwise admirable desk is not so constructed as to permit of independent adjustment to meet the inequalities of size in the same grade. This can be adequately done only by desks and seats which permit of ready and *separate* adjustment. The best forms of adjustable school furniture that have come under my notice are the "Single Standard Desk and Seat" of the "New York Hygienic School Furniture Company," and those of the "Chandler Adjustable Chair and Desk Company," of Boston. Both of these permit of a rapid, easy, and separate adjustment of the height of seat and desk, and are manufactured in three sizes designed to meet the general requirements

<sup>1</sup> Ophthalmic Review, vol. v.

of the Primary, Intermediate, and Grammar Schools. The details of their construction are sufficiently illustrated for the purpose of this paper by Figs. 27 to 31,—Figs. 27 and 28 for the former, Figs. 29, 30, and 31 for the latter. The last two figures illustrate also the method of measuring the length of the leg and the adjustment of the chair. The adjustment, once made, cannot be altered by the pupil, since it is accomplished only by the aid of a key, which should be in the hands of some authorized person. In both forms the desk and chair are screwed firmly to the floor, and are perfectly rigid, while the iron supports furnish but little obstruction to

FIG. 26.



Hygienic school desk. (Smith.)

sweeping the floor, and do not afford much opportunity for the accumulation of dust. The Chandler desk possesses the added advantage of a free space for the feet of the pupil, while the single standard desk presents some obstruction, as shown in Fig. 25. In both forms the desk is also a receptacle for the books, pencils, paper, etc., of the pupil, and is provided with a covered ink-well. Attention is called especially to the central upright support in the back of the chair in Fig. 29, which is curved forward at the proper height to furnish the requisite support to the sacrum and the lower lumbar vertebræ, and thus counteracts the tendency for the pelvis to rock backward. The following table (Table VI., page 406) of

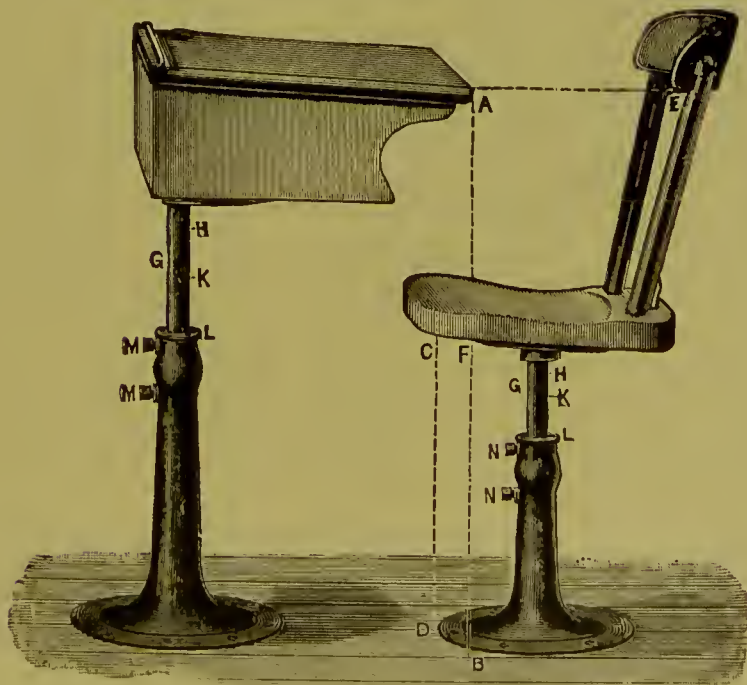
dimensions and measurements is given by the Hygienic School Furniture Company as a guide for the arrangement and adjustment of the desk and

FIG. 27.



Single standard separately adjustable seat and desk.

FIG. 28.



Adjustable seat and desk, showing their proper relative arrangement.

seat. It is based upon the tables of Erismann and Fahrner, and differs in no essential particular from the table given by Priestley Smith.

TABLE VI.

Scale numbers . . . . .	I.	II.	III.	IV.	V.	VI.	VII.	VIII.	IX.	X.	XI.	XII.	XIII.	XIV.	XV.	
Height of scholars in inches {	From	40	42	44	46	48	50	51 $\frac{1}{2}$	53 $\frac{1}{2}$	55 $\frac{1}{2}$	57 $\frac{1}{2}$	59 $\frac{1}{2}$	61 $\frac{1}{2}$	63 $\frac{1}{2}$	65 $\frac{1}{2}$	67 $\frac{1}{2}$
	To . .	42	44	46	48	50	51 $\frac{1}{2}$	53 $\frac{1}{2}$	55 $\frac{1}{2}$	57 $\frac{1}{2}$	59 $\frac{1}{2}$	61 $\frac{1}{2}$	63 $\frac{1}{2}$	65 $\frac{1}{2}$	67 $\frac{1}{2}$	and up.
Height of desk, line AB (Fig. 28)	20	20 $\frac{1}{2}$	21 $\frac{1}{2}$	22 $\frac{1}{2}$	23	23 $\frac{1}{2}$	24 $\frac{1}{2}$	25 $\frac{1}{2}$	26	26 $\frac{1}{2}$	27 $\frac{1}{2}$	28 $\frac{1}{2}$	29	29 $\frac{1}{2}$	30 $\frac{1}{2}$	
Height of chair, line CD (Fig. 28)	11	11 $\frac{1}{2}$	12	12 $\frac{1}{2}$	13	13 $\frac{1}{2}$	14	14 $\frac{1}{2}$	15	15 $\frac{1}{2}$	16	16 $\frac{1}{2}$	17	17 $\frac{1}{2}$	18	
Width of seating space, line AE } (Fig. 28).	9	9 $\frac{1}{2}$	9 $\frac{3}{8}$	9 $\frac{5}{8}$	10 $\frac{1}{4}$	10 $\frac{1}{2}$	10 $\frac{3}{8}$	11 $\frac{1}{8}$	11 $\frac{1}{2}$	11 $\frac{3}{8}$	12 $\frac{1}{8}$	12 $\frac{3}{8}$	12 $\frac{5}{8}$	13	13 $\frac{3}{8}$	

"It is recommended that the desk for a girl should be about  $\frac{3}{4}$  of an inch higher than that for a boy of the same height. The width of the seating space should be about  $\frac{5}{8}$  of an inch greater for a girl than that for a boy.

"*Directions for using the Table.*—Measure the height of the scholar; then find in the table the number that most nearly corresponds to it, and directly under it in the same column will be found the figures required for the different adjustments.

"*Example.*—A boy is found to be 52 inches in height. In column VII, 51 $\frac{1}{2}$ –53 $\frac{1}{2}$  are the nearest to it; looking down this column, we find 24 $\frac{1}{2}$  inches for the height of the desk, line AB (Fig. 28); 14 inches for the height of the chair, line CD; and 10 $\frac{3}{8}$  inches for the space between the desk and the back of the chair, line AE."

These desks have not the adjustable top which permits the pupil to stand between the desk and the seat, but this is not considered desirable by the educators with whom I have had opportunity to converse. They have invariably preferred the single instead of the double desk, and require the pupils to step quickly into the aisle when called upon to stand, holding that the position then assumed is better than when the desk is in front of the pupil, since in the latter case there is constant temptation to lean against it for support. This preference removes the necessity for any form of adjustable top or lifting seat. When such are in use, they not only cause confusion and noise, but require time for adjustment, and the additional mechanism adds cost to the forms and is always liable to get out of order.

It is doubtless true that sick, tired, or listless children will be able to assume more or less faulty positions in the most approved school form, so that teachers will be required to admonish them; but systematic instruction of teachers in the physiological and mechanical laws underlying upright sitting, which they can in turn impart to the children, will do much to correct this tendency. Careful instruction will accomplish far more than admonition or reproof, and will furthermore have a far-reaching influence over the community. A cursory study of the positions assumed by the average citizen at home or abroad will show the great need for education in this direction. Chairs are for the most part so constructed that they furnish no support for the pelvis or the lumbar vertebræ, and this faulty con-

FIG. 29.



The Chandler adjustable seat and desk.





FIG 30.



Measuring the length of the leg preparatory to adjusting the height of the seat.



struction accounts in large measure for the uncouth positions which are ordinarily assumed, since without such support the pelvis rocks backward unless sustained in the erect posture by muscular strain, which soon becomes fatiguing. It follows from the preceding remarks that no class should be considered fully organized for the work of the term until each pupil has been measured and the seat and desk have been adjusted to meet the requirements of the individual. While this will occasion additional trouble at the beginning, I am convinced that in the end it will avoid much annoyance and trouble, since a properly seated class will not suffer from the restlessness

FIG. 31.



Adjustment of seat.

occasioned by compressed viscera and impeded circulation and respiration, and will, therefore, perform their allotted tasks with less fatigue and be more orderly. I would call attention again to the strong contrast afforded by the two classes shown at their work in Figs. 17 and 18.

#### BLACKBOARDS, MAPS, BOOKS, ETC.

Other articles of school furniture which claim attention are the blackboards, wall maps and charts, slates, books, and writing-materials.

The blackboard is an important article of furniture in every school-room, not only as a convenient and valuable means of imparting instruction, but also from the point of view of the hygiene of vision. It should always be borne in mind that the strain upon the eyes is much greater at the near-point, as in reading and writing, than when looking at relatively distant objects, as at the blackboard across the school-room. Hence the

instruction imparted by board exercises is much less fatiguing than work done with slate and pencil or pen and paper. The use of the large crayon by the pupil himself is also less tiresome than work at the desk. The surface should, however, be kept black by frequent washing, as the adherent particles of chalk which remain upon it after dry cleansing soon cause it to appear gray, and thus the strong contrast between the crayon-marks and the black surface is lost. The old painted board should be banished from the school-room and only the large plates of slate or the black plaster surfaces employed. The crayon should be white or yellow for all ordinary purposes, as these colors afford the strongest contrast with the surface. The figures and letters should be made with a broad stroke and sufficiently large to be readily seen at the full width of the room.

The blackboard has been condemned because of the gray surface it so readily gains under use, and paper upon which a black crayon may be used recommended as a substitute. The soiling of the hands by the black crayon is, I think, sufficient to condemn its use for school-room purposes, except when used by the teacher, especially when the objection urged against the blackboard can be removed by daily washing its surface.

The advantage, however, of a *white* letter on a black surface or a *black* letter on a white surface cannot be denied. Professor Horner found that ink-made letters on white paper sufficiently large to be seen distinctly at *two hundred and eleven* centimetres on a clear day could be distinguished only at *one hundred and eighty-three* centimetres when made with a lead-pencil, and only at *one hundred and fifty-nine* when made with a slate-pencil on a slate-colored surface. The ratio of slate-pencil to lead-pencil was "seven to eight," that of lead-pencil to pen and ink also "seven to eight," while that of slate-pencil to pen and ink was "three to four." That is to say, an eye that can read ink-made letters of a given size at twelve inches (.33 metre) would be compelled to bring them to nine inches (.23 metre) in order to see them if made on a gray-black slate with a slate-pencil, thus causing greatly increased strain upon the accommodation and convergence. On this ground Horner advocated the banishment of the blackboard, slate, and lead-pencil from the schools. I am also willing to banish the slate and lead-pencil, but not the blackboard, since it has so many compensating features. The more modern habit of requiring so much of the work to be done with pencil and paper is probably to be condemned for other reasons, especially the protracted strain at a near-point, but if so much work at the near-point is to be continued it should be done with *black ink* and a pen with a point which will make a broad stroke. This is especially important for children with bad or defective eyes. The ordinary gray desk-slate may be advantageously replaced by the white, so-called porcelain slate, upon which a black pencil or crayon can be used. This does away in a great measure with the objection to the faint contrasts afforded by the gray surface of the ordinary slate, but is open to the objection of uncleanliness, since the hands of the

pupil are soiled in the process of cleaning the slate, and with his blackened hands he soils his face, clothing, and books.

The wall maps and charts are also important articles of school furniture, since they permit instruction to be given at a relatively remote distance. The figures and letters upon them, however, should be at least as large as No. XII. (XL.) of the chart of test-letters designed to be seen by the normal eye at twelve metres (forty feet). As far as practicable, the groundwork of maps should be white or light tints of yellow, as characters printed upon darker shades, such as red or blue, are not so readily distinguished. The teaching of geography from these large maps is a great saving of fatigue to the eyes of the pupils. Work done at the ordinary hand atlas, with its varied coloring, adopted by authors to differentiate the political divisions of the earth's surface, and the names of towns, rivers, etc., printed in small black type upon these dark colors, tries to the utmost the acuity of vision, and is probably the most injurious of the school requirements. I have very frequently asked pupils with weak eyes as to which of their lessons they found most tiresome, and have with great uniformity been told that their geography was the most trying, because of the pain occasioned by hunting for names on the atlas. Properly printed wall maps are therefore important additions to the school-room furniture.

*The Type in Text-Books.*—In considering school-room supplies there is no more important item than the securing of properly printed books. In selecting a book from the stand-point of hygiene two points should be considered: first, the kind of paper employed, and, second, the size, shape, and arrangement of the type. It is false economy to place in the hands of our children cheaply made books. Text-books for our schools should be accepted only after approval by an expert who is familiar with the many ingenious devices by which cheap publication is accomplished.

First of all, the paper should be of good quality, for the best arrangement of proper type cannot produce a satisfactory page on poor paper. Two points are important: it should be opaque, so that the shadow or shape of the type will not be seen through the paper, and it should not be bibulous, as in that case the ink stain is visible through the paper and mars more or less the impression of the type on the back of the sheet. Bluish-white or gray paper should also be avoided, although the quality may be good. Glazed papers are not admissible, since not only do they reflect the light injuriously, but the black ink and the white surface of the paper seem to encroach upon each other, producing a certain diffusion or penumbra-like effect which disturbs the distinctness of the letters. My own judgment favors first of all a thoroughly opaque paper, with either a dead white or a cream surface, preferably the latter. The thickness of the paper is of less importance than the quality of its fibre, which should be such as to prevent the absorption of the ink. A supercalendered paper, forty-five pounds to the ream, is a suitable one for most school-books. But even on paper of satisfactory quality the printing should be done in

the best manner, in order to avoid the *embossing* of the page, which interferes with the distinctness of the print on the reverse or embossed side of the sheet. Embossing is prevented by printing upon a hard, unyielding back.

The size, form, and arrangement of the type are of great importance in securing the most readily legible print. My observation has shown that but little fault can be found with the American school-book in this respect. This is certainly true of the text-books employed in the primary and intermediate schools, with the exception of the school atlas, some of the arithmetics, and all the dictionaries. In the more advanced grades some of the text-books of history are not to be commended, either as to the quality of paper employed or as to the size and arrangement of the type.

In selecting properly printed books the following points are to be observed: (*a*) the size or height and breadth of the letters and the thickness of the strokes; (*b*) their arrangement,—*e.g.*, the distance between the letters and words, known to printers as the *spacing*; (*c*) the distance between the lines, or the *leading*; and, finally (*d*), the length of the lines.

*Size and Form of the Letters.*—In order to be distinguished, letters must subtend an angle of at least five minutes, and the lines of which they are composed an angle of one minute. This is the limit of normal acuity of vision, but it is obvious that the eye should not be required to work for any length of time at a task which requires its utmost endeavor. Any effort to read pearl or diamond type for a short time must convince the most sceptical on this point, when they compare the ensuing fatigue with the ease which follows turning to a long primer type.

Both Cohn and Weber decide in favor of a type at least one and a half millimetres in height as the smallest which should be used in school-books. This is equal to our *ten-point type* (long primer). (Fig. 39.) Larger letters were found to retard the rapidity of reading, and would thus lengthen the time required to complete a given amount of work. The face of the type is of signal importance in determining its comparative legibility, and this is in large measure dependent upon the thickness, or, as printers say, the "boldness," of the strokes or "face" of the type. The so-called spacing of the line depends also upon the same factor, as in order to secure the bold stroke a certain relation must obtain between it and the open space in the letter. This makes the entire face of the letter wider, as well as the interval between the letters, and thus increases the space required for a given number of letters or words. Such print gives a much lighter appearing page, which is more easily legible, but adds materially to the cost of publication. The type-founder seems to have no mathematical rule by which the breadth of letters is fixed in relation to their height. The man who draws the design fixes the length of the type in points, each *point* being the seventy-second of an inch, but the other features are left to his artistic sense of proportion. With reference to the thickness of the lines, Cohn insists that "no print of which the down strokes are thinner than one-

fourth of a millimetre should be tolerated in school-books." Any comparison of a narrow type with a broad or "bold-faced" type must convince one of the greater legibility of the latter, and that it must, therefore, be far less fatiguing. (Figs. 36 and 37.)

*Leading.*—The distance between the lines of a printed page is of much importance in determining the comparative legibility of the page. Lines crowded together as closely as the letters which project above and below the line will permit always make a dark-appearing page and one which is relatively difficult to read. In ten-point type the distance should be at least two and a half millimetres, and in eight-point type two millimetres. The advantage of sufficient leading is illustrated in Figs. 33, 35, and 39, when contrasted with Figs. 32, 34, and 38. It is there made evident that the height of a letter is relatively of less importance than a sufficient distance between the lines. The importance of adequate spacing of the letters and words, even in the presence of proper leading, is shown in Figs. 36 and 37. Figs. 35 and 37 illustrate the advantage of a bold-faced type as compared to a thin condensed type, as shown in Fig. 36, where the vertical dimensions of the type and the leading are the same as in Fig. 37, but by the lateral condensation of the face of the type almost as much space is saved to the publisher as in the absence of leading, shown in Figs. 34 and 38. An isolated letter is much more readily made out than one closely crowded by other letters. It will be observed, for example, that the eight-point type (Fig. 35), well spaced, with a bold face and suitably leaded, is made out even more readily than the crowded ten-point type (Fig. 38) with insufficient space between the lines.

FIG. 32.

4½ Point, No. 17 (Diamond).

The model or emmetropic eye is comparatively rare, but the eyes which most nearly approach this ideal state of refraction, other things being equal, enjoy the highest acuity of vision, are freest from pain and disease, and, in the school examinations, have been found to remain in a nearly uniform percentage through all the classes, from the lowest to the highest. In the same classes the hypermetropic eyes were found to diminish steadily in percentage, while the eyes with myopic refraction increased in approximately the same ratio. Careful study of individual cases in which this increase of refraction was taking place revealed the fact that the change was associated with certain pathological conditions of the choroid, the two seeming to stand in the relation of cause and effect. Where astigmatism was also present the diminished sharpness of sight, pain, and the diseased states were more marked than when this anomaly of refraction was absent.

FIG. 33.

4½ Point, No. 17 (Diamond) leaded.

The model or emmetropic eye is comparatively rare, but the eyes which most nearly approach this ideal state of refraction, other things being equal, enjoy the highest acuity of vision, are freest from pain and disease, and, in the school examinations, have been found to remain in a nearly uniform percentage through all the classes, from the lowest to the highest. In the same classes the hypermetropic eyes were found to steadily diminish in percentage, while the eyes with myopic refraction increased in approximately the same ratio. Careful study of individual cases in which this increase of refraction was taking place revealed the fact that the change was associated with certain pathological conditions of the choroid, the two seeming to stand in the relation of cause and effect. Where astigmatism was also present the diminished sharpness of sight, pain, and the diseased states were more marked than when this anomaly of refraction was absent.

FIG. 34.

8 Point, No. 11 (Brevier).

The model or emmetropic eye is comparatively rare, but the eyes which most nearly approach this ideal state of refraction, other things being equal, enjoy the highest acuity of vision, are freest from pain and disease, and, in the school examinations, have been found to remain in a nearly uniform percentage through all the classes, from the lowest to the highest. In the same classes the hypermetropic eyes were found to diminish steadily in percentage, while the eyes with myopic refraction increased in approximately the same ratio. Careful study of individual cases in which this increase of refraction was taking place revealed the fact that the change was associated with certain pathological conditions of the chorioid, the two seeming to stand in the relation of cause and effect. Where astigmatism was also present the diminished sharpness of sight, pain, and the diseased states were more marked than when this anomaly of refraction was absent.

FIG. 36.

8 Point, M. O. S. (Brevier), leaded.

The model or emmetropic eye is comparatively rare, but the eyes which most nearly approach this ideal state of refraction, other things being equal, enjoy the highest acuity of vision, are freest from pain and disease, and, in the school examinations, have been found to remain in a nearly uniform percentage through all the classes, from the lowest to the highest. In the same classes the hypermetropic eyes were found to diminish steadily in percentage, while the eyes with myopic refraction increased in approximately the same ratio. Careful study of individual cases in which this increase of refraction was taking place revealed the fact that the change was associated with certain pathological conditions of the chorioid, the two seeming to stand in the relation of cause and effect. Where astigmatism was also present the diminished sharpness of sight, pain, and the diseased states were more marked than when this anomaly of refraction was absent.

FIG. 35.

8 Point, No. 11 (Brevier), leaded.

The model or emmetropic eye is comparatively rare, but the eyes which most nearly approach this ideal state of refraction, other things being equal, enjoy the highest acuity of vision, are freest from pain and disease, and, in the school examinations, have been found to remain in a nearly uniform percentage through all the classes, from the lowest to the highest. In the same classes the hypermetropic eyes were found to diminish steadily in percentage, while the eyes with myopic refraction increased in approximately the same ratio. Careful study of individual cases in which this increase of refraction was taking place revealed the fact that the change was associated with certain pathological conditions of the chorioid, the two seeming to stand in the relation of cause and effect. Where astigmatism was also present the diminished sharpness of sight, pain, and the diseased states were more marked than when this anomaly of refraction was absent.

FIG. 37.

8 Point, No. 11 (Brevier), leaded.

The model or emmetropic eye is comparatively rare, but the eyes which most nearly approach this ideal state of refraction, other things being equal, enjoy the highest acuity of vision, are freest from pain and disease, and, in the school examinations, have been found to remain in a nearly uniform percentage through all the classes, from the lowest to the highest. In the same classes the hypermetropic eyes were found to diminish steadily in percentage, while the eyes with myopic refraction increased in approximately the same ratio. Careful study of individual cases in which this increase of refraction was taking place revealed the fact that the change was associated with certain pathological conditions of the chorioid, the two seeming to stand in the relation of cause and effect. Where astigmatism was also present the diminished sharpness of sight, pain, and the diseased states were more marked than when this anomaly of refraction was absent.



FIG. 38.

10 Point, No. 8 (Long Primer).

The model or emmetropic eye is comparatively rare, but the eyes which most nearly approach this ideal state of refraction, other things being equal, enjoy the highest acuity of vision, are freest from pain and disease, and, in the school examinations, have been found to remain in a nearly uniform percentage through all the classes, from the lowest to the highest. In the same classes the hypermetropic eyes were found to diminish steadily in percentage, while the eyes with myopic refraction increased in approximately the same ratio. Careful study of individual cases in which this increase of refraction was taking place revealed the fact that the change was associated with certain pathological conditions of the choroid, the two seeming to stand in the relation of cause and effect. Where astigmatism was also present the diminished sharpness of sight, pain, and the diseased states were more marked than when this anomaly of refraction was absent.

FIG. 39.

10 Point, No. 8 (Long Primer), leaded.

The model or emmetropic eye is comparatively rare, but the eyes which most nearly approach this ideal state of refraction, other things being equal, enjoy the highest acuity of vision, are freest from pain and disease, and, in the school examinations, have been found to remain in a nearly uniform percentage through all the classes, from the lowest to the highest. In the same classes the hypermetropic eyes were found to diminish steadily in percentage, while the eyes with myopic refraction increased in approximately the same ratio. Careful study of individual cases in which this increase of refraction was taking place revealed the fact that the change was associated with certain pathological conditions of the choroid, the two seeming to stand in the relation of cause and effect. Where astigmatism was also present the diminished sharpness of sight, pain, and the diseased states were more marked than when this anomaly of refraction was absent.

*The Length of the Lines.*—Javal very properly condemns the quarto line, and I could wish its banishment from all new books. The long line of a quarto page is certainly more difficult to read, other things being equal, than when the page is divided into two columns. As an illustration of excellent printing, viewed both from the stand-point of the hygiene of vision and from that of the printer's art, I would call attention to the *St. Nicholas for Young Folks*. The ten-point letter with a bold face is employed, well spaced, and the lines are two and a half millimetres apart. The page is divided into two columns by a four-millimetre blank space.

*Position assumed in Writing; Kind of Script.*—The proper posture of the pupil while writing, the position of the paper, and the kind of script to be employed are questions of great interest to both teacher and physician. Fahrner, in 1879, apparently unmindful of his important teaching regarding the appropriate arrangement of the school desk, writes, "We allow our children to grow crooked in order that their handwriting may be nicely slanted," obviously favoring, therefore, the vertical script. In this he is supported by many eminent Continental authorities. Indeed, the weight of authority would seem to favor the vertical script and the placing of the paper in a central position in front of the pupil, the top and bottom of the sheet—that is to say, the ruled lines on the paper—being parallel to the plane of the body, the pupil being required to face the desk squarely, as in Fig. 25. This position of pupil and paper, together with the vertical script, is supposed to favor upright sitting, the importance of which has already been pointed out. It should be borne in mind, however, that upright sitting is dependent upon the proper relation between the desk and the chair rather than upon the nature of the required work. Assuming that the pupil is seated properly, it is probable that little attention need be given to the script he employs, so long as the paper is maintained in a central position. If he is required, however, to hold the paper with its ruled lines parallel to the edge of the desk and to the plane of his body, he will be inclined to move the paper to the right side, into the so-called *right-dexter* position. In this position the eyes must be carried to the right in a constantly increasing degree as the line on the paper increases in length from left to right. To favor the strained ocular muscles, the head is turned to the right and the spine is twisted on its long axis, a posture which must grow more and more fatiguing as the task is continued. To relieve the fatigue, the head and the body fall forward to find support on the left elbow and the desk.

All that is needed to demonstrate the fatigue which must follow this right-dexter position of the paper is the attempt to read for a few moments with the book in a corresponding position, the eyes being held to the right. An excellent example is also furnished by the fatigue experienced by copyists, whose work requires the constant movement of the eyes from one page to another. The increased tension upon the ocular muscles soon manifests itself in painful fatigue. The essential points to be kept in mind are the

upright position and that both eyes shall be at an equal distance from the paper. To secure this, a proper arrangement of the desk and seat is of primary importance. When this is secured there will be little need to question the relative advantages of the vertical or the slanting script. My own judgment is in favor of the latter, if a choice is to be made, not because it is more favorable to upright sitting, but because I am unable to see sufficient reason for replacing it by the less graceful vertical writing. In order to keep the eyes equidistant from the work, the paper must be centrally placed before the pupil. The position of the sheet in its relation to the plane of the face and the edge of the desk must determine the kind of letter it is most convenient and natural to make. If the sides of the sheet are vertical to the plane of the face, the vertical letter is most naturally made if the pen is held in the proper position in the hand,—*i.e.*, with the pen-stock resting in the crotch between the thumb and the index finger and pointing to the right shoulder. If, on the other hand, the sheet of paper is inclined to the left from twenty to thirty degrees, all other conditions remaining unchanged, the slanting script is the form that is most naturally adopted. The argument that vertical lines are less fatiguing to the eyes than those which are diagonal to the vertical meridian of the cornea falls when it is considered that with the paper inclined to the edge of the desk the lines in the slanting script are in fact vertical in their relation to this meridian of the eyes.

It is my opinion, therefore, that in properly seated and lighted school-rooms, aided by judicious instruction of teachers and pupils as to the importance of upright sitting, we may safely leave both the position of the paper and the kind of script to be employed to a process of natural selection. With the light coming from the left side of the room, there will be no temptation to carry the paper to the right side; the central position is the natural one. In a suitably arranged desk there is no temptation to turn to the left or to lean forward; the proper position is the easiest and most natural one to assume. My own observation, both in the school-room and by personal trial, seems to point to the inclined position of the paper, and consequently to the slanting script, as the most natural. To me the vertical position of the paper is in some measure a cramped one.

In the American schools the Spencerian inclined script is preferred, the paper being inclined to the edge of the desk in varying degrees,—from twenty to forty degrees. There is, however, great diversity of opinion as to the best positions. In some cases coming under my own observation the children were placed with the right side turned to the desk, the paper inclined at an angle of forty-five or even sixty degrees. The feet were also carried to the left, so that the sitting was diagonal. This position is not to be commended. In others the central position was taught, with the paper inclined to the left thirty degrees. In the class represented in Fig. 18 the teacher had adopted the central inclined position for the paper and the inclined script. But little fault is to be found with the positions assumed by the pupils. It should be observed, however, that in

the front of the room, on the right side, where the light from the left is less bright than elsewhere in the room, the children have carried the paper into the right-dexter position in their attempt to secure the light from the rear windows also, a fact which incidentally demonstrates that other factors, particularly the source of light, enter into the problem of the attitude naturally assumed by a class of school-children, if left to their choice of position, far more than the kind of script employed.

#### SPECIAL DEVICES FOR THE CARE OF WEAK EYES.

Notwithstanding every proper precaution for the prevention of harm, there will always be a large number of children in our schools who need special provision made for their welfare, if they are not to be left to the operation of the harsh law of the "survival of the fittest." I have already urged the importance of an elastic currieulum of study which would make it possible for pupils with weak eyes and feeble health to lengthen the period to be devoted to school life without being compelled to follow their class rigidly in successive promotions in all the branches.

FIG. 40.



Kallmann's face-rest.

For children who have already developed commencing near-sight, with its attending chorioiditis, much is to be gained by special devices to insure against any further increase of their disease. The tendency in such eyes is to bring the face nearer and nearer the work as the eyes become congested with use. This can be prevented by the use of a rest which will hold the head erect and at the proper reading distance. Many forms of so-called "straight holders" or crutches have been devised for this purpose, but the only one which seems worthy of commendation is that devised by Kallmann, an optician of Breslau, which he calls a "face-rest." Its general

FIG. 41.



Portable desk for use at home.



features and mode of application are made sufficiently plain by Fig. 40. Cohn says of it, "I never allow my own children to write without it, whether at home or in school, even when sitting at the best possible desk." It is screwed to the desk, and causes little, if any, annoyance. The introduction of this rest for all children with tender eyes, both at school and in their homes, is worthy of commendation.

In my practice I have long been in the habit of urging the adoption of a special portable reading desk so constructed that the book-support can be inclined to any desired angle. This is represented in Fig. 41. By its means the book is held more or less upright before the eyes, which is a distinct advantage over the flat page, and moreover removes in great measure the tendency to lean forward. Mr. Priestley Smith also has strongly urged the importance of a similar device. In home work the reading and writing desk is of signal importance, since at home the child is likely to be left to his own choice of position. I have frequently urged upon the parents of children under treatment for their defective eyes the purchase, for home use, of some form of the hygienic desk represented in Figs. 27-30, which has the added advantages of the properly adjusted seat and a receptacle for books and other school materials. It is supplied with a movable platform, upon which the desk and seat are firmly screwed, and can be placed in any convenient place for light, or be moved out of the way when not in use. In the case of children with weak eyes, I have forbidden the use of pen or pencil and paper at home, and advised a black-board. It should be placed upon an easel or hung at the proper height against the wall. I esteem this expedient of much value in preventing the strain upon tender eyes in the preparation of lessons at home.

#### CONCLUSIONS.

The conclusions which seem to be borne out by the discussion in the preceding pages may be briefly summarized as follows:

*First.* The schools cannot be held solely responsible for the harm which befalls the eyes of the school-children during the educational process, since it has been shown that a very large percentage of the children enter the schools with congenitally defective eyes. This conclusion is strengthened by the fact that these defective eyes have been shown to be especially liable to injury, while the model or emmetropic eye and the eyes most nearly approaching this ideal state of refraction enjoy the highest acuity of vision, are comparatively free from pain, and maintain a nearly uniform percentage in all the grades of school life.

*Second.* In the light of the preceding conclusion, it is highly important that every child seeking to enter the schools should be subjected to a systematic examination as to the state of the vision, and where this is found defective the parents should be notified and advised of the probable harm which will result from the school work if professional advice is not secured.

*Third.* The skilful correction of the errors of refraction in our children's

eyes by glasses would go far to arrest the acquisition of near-sight and its attending pathological conditions, and in most cases would prevent also the asthenopia which precedes and accompanies the increase of refraction.

*Fourth.* The very great frequency of these congenital anomalies should stimulate our school authorities to the adoption of every sanitary precaution and to the most scrupulous avoidance of faulty educational methods.

The following suggestions should be borne in mind as important :

(a) Sufficient light, properly admitted to the school-room, should be regarded as a fundamental requirement in school-house architecture. The light should be admitted from the left side of the pupils, and the ratio of window surface to floor surface should never fall below one to five, and this should be exceeded in many localities, on the north side of buildings and on the ground-floors.

(b) The desks and seats should be of such a pattern as will permit independent adjustment as to height and size to meet the requirements of individual pupils, and should be arranged with a minus horizontal distance, in order to insure upright sitting.

(c) Instruction should be imparted as far as possible by means of black-boards, wall maps, charts, and orally, instead of by work at a near-point, as with peneil and paper or slate. Where the work must be done at a near-point, a pen and black ink should be used instead of a lead-peneil or slate and peneil.

(d) The work required to be done at home should be in large measure abandoned, or at least largely reduced.

(e) A more elastic curriculum of study is desirable for pupils with weak eyes or feeble health, which will permit the lengthening of the school life and at the same time admit of steady promotion.

(f) The system of term examinations should be abandoned entirely.

(g) Great care should be exercised in the selection of properly printed text-books. Only good paper, and type no smaller than eight-point, or preferably ten-point, are admissible in school-books, and these should be bold-faced and well spaced, on a double-column page. For the former a distance of two millimetres between the lines, and for the latter a distance of two and one-half millimetres, should be required.

(h) In writing, the central position of the paper should be maintained, but in properly lighted rooms with suitably arranged seating the kind of script, vertical or slanting, will depend upon the vertical or the inclined position of the paper, and may safely be left to natural selection.



# BLINDNESS: ITS FREQUENCY, CAUSES, AND PREVENTION.

BY I. MINIS HAYS, A.M., M.D.,  
Philadelphia, Pa., U.S.A.

---

DEFINITION.—Blindness is properly defined as an incurable total loss of sight. The popular definition of it, however, is that condition in which the sight is so diminished that any occupation requiring the use of the eyes is impracticable.

## STATISTICS.

According to George Mayr,<sup>1</sup> there were in the year 1876 in the entire world 208,381,478 inhabitants, of whom 180,537, or .000866 per cent., were blind, or one blind person to every 1154 inhabitants. Statistics of blindness based on the census of population are not, however, absolutely reliable. It is believed that the census returns generally materially underrate the number of blind, owing, probably, to the fact that those who are of defective sight, although able to walk about and to distinguish light from darkness, but practically blind, are disinclined to return themselves as such. This belief has been confirmed by a careful inquiry into the number of blind in the population of the three Scottish counties of Lanark, Renfrew, and Ayr, made after the taking of the British census of 1881, when it was found that the number of blind was 173 in excess of the number given in the Census Report, and for the whole of Scotland it was estimated as 15½ per cent. in excess of the census return. Zehender,<sup>2</sup> too, has critically examined the data for the Grand Duchy of Mecklenburg, and has found that many blind inhabitants were not counted as such, while some who could see were enumerated as blind, and that no accurate distinction had been made between blindness and a high degree of weak sight, nor between curable and incurable blindness.

The *proportion of blind to the entire population* varies in different countries, owing to occupation, climatic peculiarities, and other causes, which will be considered in detail hereafter. The following table, compiled from the Report of the Eleventh Census of the United States and from statistics given

---

<sup>1</sup> Cohn, Lehrbuch der Hygiene des Auges, s. 758.

<sup>2</sup> Klin. Monatsblätter für Augenhk., 1870, s. 277.

by Corradi in 1886,<sup>1</sup> exhibits the proportion of blind to one million of population in various countries, arranged in the order of increasing frequency, as follows :

*Proportion of Blind to One Million of Inhabitants.*

Holland (1889) . . . . .	445	Bavaria (1871) . . . . .	822
Baden (1871) . . . . .	524	Prussia (1880) . . . . .	831
Canada . . . . .	619	German Empire . . . . .	870
Hesse (1880) . . . . .	629	France (1883) . . . . .	947
Denmark (1880) . . . . .	653	Spain (1860) . . . . .	1109
Scotland (1891) . . . . .	698	Ireland (1891) . . . . .	1135
Poland . . . . .	700	Hungary (1880) . . . . .	1332
Austria (1890) . . . . .	710	Norway (1865) . . . . .	1363
Saxony (1880) . . . . .	711	Russia (1886) . . . . .	about 2000
Switzerland . . . . .	761	Argentine Republic . . . . .	2024
Italy (1881) . . . . .	761	European Russia (1869) . . . . .	2100
United States (1890) . . . . .	808	Portugal . . . . .	2190
England and Wales (1891) . . . . .	809	Finland (1873) . . . . .	2226
Belgium (1856) . . . . .	811	Iceland . . . . .	3400
Sweden (1880) . . . . .	816		

The countries showing the highest percentage, arranged in the order of diminishing proportion, are Iceland, Finland, Portugal, European Russia, and the Argentine Republic, and the percentage of the United States is slightly below the world's average.

*United States.*—According to the census of 1890, out of a total population of 62,622,250, the total number of persons returned as blind in both eyes was 50,568, which is in the proportion of 808 to a million of population, or one blind to every 1238 inhabitants. The corresponding figures in 1880 were : total number of blind, 48,928 ; and the number per 1,000,000 of population, 976, or one blind to every 1032 inhabitants. The decrease in the proportion of blind in 1890 is probably in part a real one, corresponding with the decrease which has occurred in Great Britain and other countries, and in part may be due, according to the Eleventh Census Report, to a less complete enumeration of this class of population than was made in 1880. Among the males, according to the census of 1890, there were 28,080 blind in a total of 32,067,880, or one in every 1142 of population ; and among the females, 22,488 in a total of 30,554,370, or one in every 1359 of population.

Of the 50,568 blind, 43,351, or 788 per million of population, belonged to the white race, and 7217, or 945 per million of population, to the colored race ; the proportion of blind is, therefore, somewhat greater among the colored race than among the whites.

41,390, or 775 per million of population, were native-born, and 9178, or 992 per million of population, were of foreign birth ; the proportion of blind is, therefore, greater among the foreign-born than among the native population.

<sup>1</sup> *Annali universali di medicina e chirurgia*, vol. cclxxv. p. 174.

The following table shows the respective ages of the blind population:

*The Blind in the United States—Census of 1890.*

Sex.	Total.	Age Un- known.	0-5	5-10	10-15	15-20	20-25	25-30	30-35	35-45	45-55	55-65	65-75	75-85	85 and upward.
Males . . . .	27,983	339	401	789	1094	1207	1124	1160	1225	2802	4064	4186	4545	3650	1397
Females . . .	22,428	236	362	632	975	1011	941	877	926	1920	2275	2962	3627	3733	1951
Total . . . .	50,411	575	763	1421	2069	2218	2065	2037	2151	4722	6339	7148	8172	7383	3348

From a study of the detailed table from which the preceding table has been compiled, it is found that the proportion of blind rapidly increases up to the age of twenty; between the ages of twenty and thirty there is either no increase or an actual decrease; and after the age of thirty the proportion increases gradually until the age of forty-five is reached, after which period the increase is very rapid up to the age of seventy-five. This diminution in the proportion of the blind between the ages of twenty-five and thirty-five exists in the white and the colored races and in the males and the females, and it is also seen in the statistics of England and Wales. It is probably due to the fact that the number of persons who become blind between twenty and thirty years of age is proportionately small.

Of the 50,568 cases of blindness in the United States, 4267, or 8.4 per cent., were *congenital*. Of these, 2346 were males and 1921 females. The ages were as follows:

*Congenitally Blind by Age-Groups—U.S. Census of 1890.*

Age-Groups.	Number.	Ratio to 1000 of the Congeni- tally Blind.
Unknown . . . . .	52	
Under five years . . . . .	378	89.68
From 5 to 10 years . . . . .	476	112.93
From 10 to 15 years . . . . .	566	134.28
From 15 to 20 years . . . . .	538	127.64
From 20 to 25 years . . . . .	427	101.31
From 25 to 30 years . . . . .	355	84.22
From 30 to 35 years . . . . .	287	68.09
From 35 to 45 years . . . . .	434	102.96
From 45 to 55 years . . . . .	333	79.00
From 55 to 65 years . . . . .	206	48.88
From 65 to 75 years . . . . .	122	28.94
From 75 to 85 years . . . . .	62	14.71
85 years and upward . . . . .	31	7.36

The highest number in any age-group, it will be seen, was found in that from ten to fifteen, and, allowing for errors of omission, it still seems probable that the number of congenitally blind infants born has been very appreciably diminishing during the past fifteen years, and there can be but little doubt that this is largely owing to our better methods for the prevention and cure of ophthalmia neonatorum.

The proportion of the blind to total population increases steadily with advancing age. The following table shows the number of blind in each of

certain age-groups per one hundred thousand of population in these age-groups in the United States and in England and Wales, Scotland and Ireland:

*The Blind in Age-Groups per One Hundred Thousand of Population.*

Countries.	Under 15 Years.	15-25.	25-35.	35-45.	45-55.	55-65.	65 and over.
United States (1890) . . . . .	19.3	34.0	43.3	67.9	126.9	230.8	789.9
England and Wales (1891) . . . . .	20.8	37.7	46.1	74.8	116.4	214.3	602.0
Scotland (1891) . . . . .	15.2	29.6	45.1	68.9	99.6	173.0	503.7
Ireland (1891) . . . . .	9.1	24.1	54.8	105.7	186.6	298.0	753.6

A study of the United States census tables exhibiting the ratios of the congenital blind in each of certain age-groups per one hundred thousand of population in each of these age-groups, shows that the proportion of the congenital blind remains about the same in each age-group until the period of sixty-five years and upward is reached, when it slightly increases. This indicates that the death-rate of the congenital blind is about the same as that of the rest of the population until the age of sixty-five years is reached, when it becomes somewhat lower than the average. The increase in the proportion of the blind with advancing age is entirely among the non-congenital blind, and is due to causes acting at all ages to destroy vision.

The total number of *pupils in schools for the blind* in the United States was 1499. Taking the average school age as being between five and twenty years of age, there were 5708 blind of school age, of whom only 1105, or 19.36 per cent., were at school; the proportion being a little greater for males than for females, and more than twice as great for the white as for the colored population.

*Great Britain.*—According to the census of 1891, the total number of persons returned as blind in England and Wales, out of a population of 29,002,525, was 23,467, which is in the proportion of 809 to a million of population, or one blind to every 1236 inhabitants. Among the males, one in every 1144 was so affected, and among the females, one in every 1336.

The respective ages of the blind population of England and Wales are shown in the following table, extracted from the Census Report for 1891. The total population was 29,002,525, of which 14,052,901 were males and 14,949,624 were females.

*The Blind in England and Wales—Census of 1891.*

Returned as	All Ages.													85 and upward.	
	Persons.	M. & F.		0-	5-	10-	15-	20-	25-	35-	45-	55-	65-		75-
Blind from childhood .	4,005	M.,	2,194	297	346	235	269	201	301	206	153	109	54	21	2
		F.,	1,811	253	292	188	176	170	250	187	130	96	51	15	3
Blind, others . . . . .	19,462	M.,	10,087	297	316	263	345	369	864	1295	1599	1796	1878	1389	289
		F.,	9,375	253	292	250	302	279	605	802	1025	1550	2108	1914	540
Total blind . . . . .	23,467	M.,	12,281	297	346	498	614	570	1165	1501	1752	1905	1982	1410	291
		F.,	11,186	253	292	438	478	449	855	989	1155	1646	2159	1929	543

The proportion of the blind to the population has decreased with each successive enumeration since 1851, when the blind were included in the census for the first time; but the decrease in the decade ending 1891 was much greater than in any of the preceding decennial intervals.

*Table showing the Diminution in the Proportionate Number of Blind in England and Wales.*

Year.	Number of Blind.	Persons enumerated to One Blind Person.
1851 . . . . .	18,306	979
1861 . . . . .	19,352	1037
1871 . . . . .	21,590	1052
1881 . . . . .	22,832	1158
1891 . . . . .	23,467	1236

The total number of persons returned as blind in Scotland, according to the census of 1891, out of a total population of 4,033,103, was 2797, which is in the proportion of 695 to a million of population, or one blind person to every 1439 inhabitants. Among the males, one in every 1371 is so affected; among the females, one in every 1509.

The respective ages of the blind population of Scotland are shown in the following table, extracted from the Census Report. The total population was 4,033,103, of which 1,951,461 were males and 2,081,642 were females.

*The Blind in Scotland—Census of 1891.*

Returned as	All Ages.													85 and upward.	
	Persons.	M. & F.		0-	5-	10-	15-	20-	25-	35-	45-	55-	65-		75-
Blind from childhood . . . . .	359	M.,	188	5	16	23	25	21	41	26	17	8	5	0	1
		F.,	171	12	20	25	18	14	29	25	9	9	6	4	0
Blind, others . . . . .	2438	M.,	1229	14	28	25	46	47	119	168	181	214	194	154	39
		F.,	1209	9	19	23	32	29	74	86	137	180	255	262	103
Total blind . . . . .	2797	M.,	1417	19	44	48	71	68	160	194	198	222	199	154	40
		F.,	1380	21	39	48	50	43	103	111	146	189	261	266	103

The proportion of the blind to the population of Scotland has decreased with each successive enumeration since 1871, when the blind were included in the census for the first time; but the decrease in the decade ending 1891, as in England and Wales, was much greater than in the preceding decennial intervals.

*Table showing the Diminution in the Proportionate Number of Blind in Scotland.*

Year.	Number of Blind.	Persons enumerated to One Blind Person.
1871 . . . . .	3019	1112
1881 . . . . .	3158	1182
1891 . . . . .	2797	1439

The total number of persons returned as blind in Ireland, according to the census of 1891, out of a total population of 4,706,162, was 5341, which is in the proportion of 1135 to a million of population, or one blind person to every 881 inhabitants. Among the males, one in every 901 is so affected; among the females, one in every 863.

The respective ages of the blind population of Ireland are shown in the following table, extracted from the Census Report. The total population was 4,706,162, of which 2,317,076 were males and 2,389,086 were females.

*The Blind in Ireland—Census of 1891.*

All Ages.	0-	5-	10-	15-	20-	25-	35-	45-	55-	65-	75-	85 and upward.
Males . . . 2572	10	29	40	56	67	164	255	405	488	474	430	154
Females . . . 2769	8	19	34	55	62	164	261	451	508	542	468	197
Total . . . 5341	18	48	74	111	129	328	516	856	996	1016	898	351

The proportion of the blind to the population has apparently not decreased with each successive enumeration, as is shown in the following table :

*Table showing the Proportionate Number of Blind in Ireland at each Census Decade.*

Year.	Number of Blind.	Persons enumerated to One Blind Person.
1851 . . . . .	7587	864
1861 . . . . .	6879	843
1871 . . . . .	6347	852
1881 . . . . .	6111	847
1891 . . . . .	5341	881

The Commissioners of the Census of 1851 attributed the large proportion of cases of blindness to the fact that during the three preceding years no less than 86,959 cases of epidemic ophthalmia were treated in the Irish workhouses. During the next decade the total population was decreased by 753,760, and the blind by 708. This decrease was mainly owing to the great stream of emigration to America; and as emigrants were prohibited from taking their blind relatives with them, the ratio of that class to the remaining population consequently increased. The slight increase in the proportion observed in the decade of 1871-81 was probably also owing to the large emigration during that period.

In *France*, including *Algeria*, according to the census statistics of 1883,<sup>1</sup> in a population of 40,803,395, there were 38,632 blind, or one blind to every 1056 inhabitants. Of these, 3794 (2132 males and 1662 females), or 9.8 per cent., were under twenty-one years of age, and 34,838 (19,684 males and 15,154 females), or 90.2 per cent., were adults.

<sup>1</sup> Trousseau, *Hygiène de l'Œil*, Paris, 1892.

In *Holland*, according to the census of 1869, there were 1593 blind persons, or one in every 2247 inhabitants.<sup>1</sup>

In *Denmark*, according to the census of 1870, there were 1249 blind (577 males and 672 females), or one blind to every 1428 inhabitants.<sup>2</sup>

The *German Empire*, with a total population of about 45,000,000, has about 39,000 blind, or one to every 1154 inhabitants.<sup>3</sup>

*Austria*.—The number of blind in the provinces represented in the Reichsrath amounted to 15,582 in the year 1884.<sup>4</sup> Of these, 2325 were children under fifteen years of age,—namely, 433 were below five years, 779 from five to ten years, and 1113 from ten to fifteen years.

*The Blind in Hungary.*<sup>5</sup>

	Men.	Women.	Total.	Proportion to every 10,000 Inhabitants.
In 1870 . . . . .	9,800	8,723	18,523	12
In 1880 . . . . .	10,242	10,597	20,839	13
Increase . . . . .	442	1,874	2,316	1

*Classification of the Blind according to Age—Hungarian Census of 1880.*

Age.	Males.	Females.	Total.	Per Cent.
Up to 2 years . . . . .	122	101	223	1.07
3- 5 years . . . . .	194	208	402	1.93
6-10 years . . . . .	443	379	822	3.95
11-15 years . . . . .	495	498	993	4.77
16-20 years . . . . .	479	455	934	4.48
21-30 years . . . . .	930	846	1,776	8.52
31-40 years . . . . .	1,016	1,101	2,117	10.16
41-50 years . . . . .	1,346	1,282	2,628	12.61
51-60 years . . . . .	1,570	1,752	3,322	15.94
Above 60 years . . . . .	3,631	3,959	7,590	36.42
Unknown . . . . .	16	16	32	0.15
Total . . . . .	10,242	10,597	20,839	100.00

*Italy*.—The number of blind, according to the census of 1881, was 21,718, and those of school age were estimated to form about twenty-five per cent. of the whole, or about 5429.<sup>6</sup>

In *Sweden*, according to the census of 1880, there were 3723 blind, or one blind person for every 1226 of the population.<sup>7</sup>

In *Finland* there were 22.26 blind in every 10,000 inhabitants, 15.14 being males and 29.38 females. The northern districts show a particularly large proportion of blind,—viz., 30 to every 10,000 inhabitants. In the

<sup>1</sup> Report of the Royal Commission on the Blind of the United Kingdom, London, 1889, ii. p. 78.

<sup>2</sup> *Ibid.*, p. 78.

<sup>3</sup> *Ibid.*, p. 77.

<sup>4</sup> *Ibid.*, p. 80.

<sup>5</sup> *Ibid.*, p. 81.

<sup>6</sup> *Ibid.*, p. 82.

<sup>7</sup> *Ibid.*, p. 79.

cities the proportion was 8.26, whilst in the country it was 22.43 to every 10,000 inhabitants.<sup>1</sup>

*Russia.*—The total number of blind in Russia, Poland, and Caucasia, according to the census returns of 1886, was 189,909 in a general population of about 100,000,000;<sup>2</sup> but the average varied considerably in the different provinces, and was much greater in the country than in the cities, and in the northeastern half of Russia than in the southwestern.

*The Blind in Russia—Census of 1886.*

	Number of Blind to 10,000 Inhabitants.	Persons enu- merated to One Blind Person.
European Russia . . . . .	21	476
Poland . . . . .	7	1429
Caucasia . . . . .	15	667
Average . . . . .	20	500

*Number of Blind to Ten Thousand Inhabitants.*

	In Cities.	In the Country.
European Russia . . . . .	11	23
Poland . . . . .	6	7
Caucasia . . . . .	10	16
Entire Russian Empire . . . . .	10	21

RELATION OF CLIMATE TO BLINDNESS.

The exact climatic peculiarities, if any, which conduce to the causation of blindness have not yet been definitely determined. Blindness is more frequent in hot than in temperate and cold countries, and on the sea-coast than in elevated districts. Sormani found the proportion of blind largely increased in the maritime regions of Italy, and Dumont has found the same in France. In Belgium, the coast shows the largest (9.67 per 10,000) and the southern hilly provinces the smallest proportion (5 and 5.16). Switzerland has a remarkably small proportion of blind (7.61), whilst the equally mountainous Norway possesses a very large proportion.

The reflected light of the sun in the warm climates of the south and the glare of the snow in the cold climates of the north are probably important factors in the production of blindness. Dust and strong winds are also climatic factors, and the squalor and loose habits of life which prevail in hot countries and in sea-coast towns favor the spread of contagious eye-affectations which have blindness for their frequent sequel. It is by no means certain, however, that an individual placed under favorable hygienic conditions and properly protected from harmful surroundings would run

<sup>1</sup> Schaefer, Ein Beitrag zur Blindenstatistik, Kiel, 1893.

<sup>2</sup> Ibid.



greater risks in regard to his sight in a hot than in a cold country, or at the sea-side than in the valley. Nor are particular eye-diseases confined to certain countries. Epidemic trachoma used to be thought to be peculiar to Egypt and Arabia, but it is now known to prevail more widely, and to be found in Sweden and in Ireland as well as on the borders of the Nile.

The vastly larger proportion of cases of blindness observed in hot and cold than in temperate countries has led Zeune to formulate a law, according to which the proportion of cases of blindness is less in the temperate than in the frigid zone, and rapidly increases in the torrid zone as the equator is approached. His statistics give approximately the following distribution of blind to population:

Between 20° and 30° of latitude . . . .	1 blind in every 100 of population.
Between 30° and 40° of latitude . . . .	1 blind in every 300 of population.
Between 40° and 50° of latitude . . . .	1 blind in every 800 of population.
Between 50° and 60° of latitude . . . .	1 blind in every 1400 of population.
Between 60° and 70° of latitude . . . .	1 blind in every 1000 of population.

A study of the statistics of the individual countries does not show an entire conformity to this law. Thus, Norway has 13.63 blind per 10,000, and Finland 22.45; whereas Sweden, which lies between them, has only 8.05. Nevertheless, the general truth remains, that blindness is more common in the frigid and torrid than in the temperate zones.

If the United States be divided into three areas according to latitude, the first comprising all the territory below the thirty-fifth degree of latitude, the second the area between the thirty-fifth and fortieth degrees, and the third the area above the fortieth degree, we find, as pointed out by Howe,<sup>1</sup> that there is a constant increase in the proportion of the blind to the population as we pass from the north to the south.

In the first (or northerly) range the proportion of the blind to every 100,000 inhabitants is . . . . .	66.7
In the second (or middle) range the proportion of the blind to every 100,000 inhabitants is . . . . .	77.8
In the third (or southern) range the proportion of the blind to every 100,000 inhabitants is . . . . .	92.1

This is in accord with the aforementioned law formulated by Zeune.

If the United States be divided according to longitude into three groups, each including about fifteen degrees, we find that the proportion of blindness decreases as we pass from the east to the west. In this division the first group of States lies between the Atlantic Ocean and the Mississippi River, the second extends from the Mississippi River to the Rocky Mountains, and the third from the Rocky Mountains to the Pacific Ocean. According to the census of 1890,

In the eastern group there are 80 blind to each 100,000 inhabitants;
In the middle group there are 76.2 blind to each 100,000 inhabitants; and
In the western group there are 40.3 blind to each 100,000 inhabitants.

---

<sup>1</sup> Transactions of the American Ophthalmological Society, 1887.

These figures show that the greatest proportion of blindness is nearest the centre of density of population, and also nearest that portion of the country where immigration would be apt to exercise the greatest influence upon the native population.

While the above figures show a uniformity for large groups of States, a like uniformity does not obtain for the individual States forming these groups, or the counties composing these States. According to the census of 1890, the proportion of blind was greatest in the following widely separated States, and in the order given : New Mexico, Vermont, Kentucky, Virginia, Tennessee, Arkansas, and Maine ; and while New Mexico has a ratio of 209.6 per 100,000 of population, the adjoining State of Colorado has a ratio of only 45.9, and Arizona of 47. Maine has a ratio of 101.7, Vermont of 131.8, while Massachusetts has but 82.4 and New York but 73.2. The differences in the ratios in the several States, according to the Census Report, "are in part due to differences in the proportion of persons of advanced age in the population, in part to previous epidemics of eruptive fevers in certain localities, and in part, perhaps, to heredity in certain families."

In the United States the blind show no tendency to collect in the large cities. In the cities of 50,000 inhabitants and upward the aggregate number of blind was 6272, which is in the ratio of 535 per million of population, and is about thirty-three per cent. below the average rate for the whole country. This indicates that not only is there no tendency for the blind to collect in the large cities, but that the largest proportion of the blind to the population is found in the small towns and rural districts. The figures previously quoted show the same to be true of Russia.

#### RELATION OF AGE TO BLINDNESS.

According to Magnus,<sup>1</sup> the first five years of life present the greatest danger of loss of sight.

From the fifth to the twentieth year the danger is relatively smallest.

From the twentieth to the fiftieth year the danger constantly increases, but not in progressive proportion.

From the fiftieth to the sixtieth year the liability to blindness rapidly increases.

From the sixtieth year this liability appears to diminish.

In early childhood the danger of injury to sight by traumatism is very great, and in 233 cases of blindness, Seidelmann has found 40, or seventeen per cent., attributable to injuries caused by playthings. A large proportion of the blind from accidents or various other causes lose their sight during adult age, especially between the ages of forty-five and sixty-five.

The British Royal Commission on the Condition of the Blind (1889) estimates the average age of the blind as forty-nine, and the average commencing age of blindness as thirty-one years.

Of the 50,411 cases of blindness noted in the United States census of

---

<sup>1</sup> Die Blindheit, ihre Entstehung und ihre Verhütung, Breslau, 1883, s. 240.

1890, the age at which blindness occurred was not reported in 5790; of the remaining 44,621, the age at which blindness came on is shown in the following table:

*Age at which Blindness occurred—U.S. Census of 1890.*

Sex.	At Birth.	Under 1 Year.	1-5.	5-10.	10-20.	20-50.	50 Years and over.
Males . . . . .	2346	712	1349	1376	2192	8,332	8,409
Females . . . . .	1921	669	1191	1206	1650	4,743	8,525
Total . . . . .	4267	1381	2540	2582	3842	13,075	16,934

The following table shows for each 1000 blind for whom the age when blindness occurred is known, the number in which it occurred at certain ages:

*Age at which Blindness occurred per One Thousand Blind—U.S. Census of 1890.*

Sex.	Birth.	Under 1 Year.	1-5.	5-10.	10-20.	20-50.	50 Years and over.
Males . . . . .	94.92	28.81	54.58	55.67	88.69	337.11	340.22
Females . . . . .	96.51	33.61	59.83	60.59	82.89	238.28	428.29
Total . . . . .	95.63	30.95	56.92	57.87	86.10	293.02	379.51

The following table shows the age at which blindness came on in the 5341 cases embraced in the census of Ireland of 1891:

*Age at which Blindness occurred—Census of Ireland, 1891.*

Age.	Number of Cases.	Per Cent.
Congenital . . . . .	280	5.24
Under 5 years . . . . .	320	5.99
From 5 to 10 years . . . . .	269	5.04
From 10 to 15 years . . . . .	285	5.34
From 15 to 20 years . . . . .	269	5.04
From 20 to 25 years . . . . .	296	5.54
From 25 to 30 years . . . . .	266	4.98
From 30 to 35 years . . . . .	258	4.83
From 35 to 40 years . . . . .	237	4.44
From 40 to 45 years . . . . .	258	4.83
From 45 to 50 years . . . . .	256	4.79
From 50 to 55 years . . . . .	296	5.54
From 55 to 60 years . . . . .	312	5.84
From 60 to 65 years . . . . .	364	6.82
From 65 to 70 years . . . . .	326	6.10
From 70 to 75 years . . . . .	299	5.60
From 75 to 80 years . . . . .	260	4.87
From 80 to 85 years . . . . .	149	2.78
From 85 to 90 years . . . . .	76	1.42
90 years and upward . . . . .	27	0.51
Unspecified . . . . .	238	4.46
Total . . . . .	5341	100.00

The quinquennial period at which the greatest number of cases of blindness occurred in Ireland was from sixty to sixty-five years, but in the census of 1881 it was the period from sixty-five to seventy years.

Zehender<sup>1</sup> gives the following table of the age at which blindness occurred in 513 blind persons in the Duchy of Meeklenburg:

*Age at which Blindness occurred in Mecklenburg.*

Age.	Number of Cases.
Born blind . . . . .	45
Became blind in first year . . . . .	58
From 1 to 10 years . . . . .	52
From 11 to 20 years . . . . .	45
From 21 to 30 years . . . . .	41
From 31 to 40 years . . . . .	48
From 41 to 50 years . . . . .	47
From 51 to 60 years . . . . .	54
From 61 to 70 years . . . . .	57
From 71 to 80 years . . . . .	30
From 81 to 90 years . . . . .	6
Over 90 years . . . . .	1
Age not given . . . . .	29
Total . . . . .	513

#### RELATION OF SEX TO BLINDNESS.

More cases of blindness are found among males than among females. According to the United States census of 1890, one in every 1142 males was blind and one in every 1359 females, and for each 1000 blind there were 555 males and 445 females; in 1880 the corresponding figures were 547 males and 453 females. For the congenital blind in 1890, the figures were 550 males and 450 females. The proportion of blind among the males in the United States is about the average which prevails at the present time in the principal countries of the world, but the proportion of blind among the females is decidedly below the average.

In England, according to the census of 1891, one in every 1144 males was blind and only one in every 1336 females, and in each of the five preceding censuses in which account of the blind has been taken the same preponderance of blindness among males has been found; and this proportion appears natural, as in most parts of America and Europe more boys are born than girls, and males, by their occupation, are more exposed than females to accidents which result in loss of sight. This rule, however, is not uniform, as will be seen by examination of the accompanying table, taken from the United States Census Report of 1891, from which it will be observed that in the northern countries, where the proportion of the blind is increased, the relation is reversed, and the larger proportion of cases among females here found is difficult to explain. It is curious to note, too, that this preponderance of blindness among females is also found in Ireland, according to the census of 1891 and previous enumerations. In this respect Ireland agrees

<sup>1</sup> Klin. Monatsblätter für Augenhk., 1870, ss. 277-379.

with Finland and the Scandinavian countries in the north of Europe. The last census of Ireland, however, shows a slight diminution in the proportion of females compared with the returns of the three preceding censuses,—viz. :

Census of 1861 . . . . .	100 males to 118.4 females.
Census of 1871 . . . . .	100 males to 110.0 females.
Census of 1881 . . . . .	100 males to 111.5 females.
Census of 1891 . . . . .	100 males to 107.3 females.

The average proportion for the past four decades is 100 blind males to 111.8 blind females.

*Blind per Million of Each Sex.*

Country.	Males.	Females.	Country.	Males.	Females.
United States . . . . .	876	736	Denmark . . . . .	655	743
England and Wales . . . . .	873	748	Sweden . . . . .	766	842
Scotland . . . . .	729	662	Norway . . . . .	1313	1411
Ireland . . . . .	1109	1160	Finland . . . . .	1514	2937
Russia . . . . .	845	817	Iceland . . . . .	3504	1773
Bavaria . . . . .	822	822	Italy . . . . .	851	686
Saxony . . . . .	790	706	Spain . . . . .	1225	996
Austria . . . . .	779	655	Newfoundland . . . . .	529	817
Hungary . . . . .	1329	1334	Nova Scotia . . . . .	561	556
France . . . . .	845	699	Jamaica . . . . .	2613	2968
Belgium . . . . .	981	640	Barbadoes . . . . .	1701	1433
Holland . . . . .	499	393	Argentine Republic . . . . .	2134	1907

As a rule, the number of blind males exceeds that of females at all ages up to sixty years, after which period the females outnumber the males at like ages. In the United States, however, according to the census of 1890, it is not until the quinquennial period of eighty to eighty-five is reached that the females outnumber the males.

THE CAUSES OF BLINDNESS.

In 50,411 cases of double blindness enumerated in the Eleventh United States Census, the cause of blindness was unknown in 14,456. Of the remaining 35,955 cases, the cause was given as follows :

*Table of Causes of Blindness—U.S. Census of 1890.*

Cause.	Total.	Per Cent.	Males.	Females.
Congenital . . . . .	4267	11.87	2346	1921
Disease of the eye itself . . . . .	5455	15.17	2973	2482
Injury . . . . .	7134	19.84	5618	1516
Cataract . . . . .	4875	13.56	2447	2428
Scrofula and other blood-diseases . . . . .	1822	5.07	835	987
Small-pox . . . . .	448	1.25	269	179
General fever . . . . .	1213	3.37	637	576
Scarlet fever . . . . .	556	1.55	253	303
Measles . . . . .	889	2.47	476	413
Brain-disease . . . . .	2366	6.58	1006	1360
Glaucoma . . . . .	209	.58	90	119
Disease of one eye following injury of the other eye . . . . .	158	.44	121	37
Cancer . . . . .	82	.23	42	40
All other causes . . . . .	5738	15.96	2504	3234
Resulting from military service . . . . .	743	2.07	743	. .

It will be seen from the preceding table that 19.84 per cent. of cases of blindness from known causes were due to injury, and that the proportion due to this cause was much greater among males than among females; also that the proportion of cases which were congenital or due to disease of the eye itself, to cataract, to small-pox, to fevers (except scarlet fever), and to measles, was greater among males than among females; while the proportion of cases due to scrofula, scarlet fever, diseases of the brain, and glaucoma was greater among females than among males.

Statements as to the causes of blindness obtained in the usual course of a census enumeration are not sufficiently accurate for trustworthy deductions. To be available for such purpose, the reported cause of blindness in each case, before acceptance, should be confirmed by an examination by an ophthalmologist, and in many cases of long standing it is very difficult, or even impossible, to ascertain the real cause even in this way. Hence the reliable statistics of the causes of blindness in both eyes which have as yet been published embrace but a relatively small number of cases, and for these we are chiefly indebted to Magnus in Germany, Trousseau in France, and Oppenheimer in the United States.

As regards the *anatomical seat* of the disease causing blindness in both eyes, Magnus<sup>1</sup> gives the following table based upon 1037 cases observed by von Landesberg, Bremer, and himself:

*Anatomical Seat of the Disease causing Blindness.*

	Number of Cases.	Per Cent.
Optic nerve . . . . .	242	23.33
Uveal tract . . . . .	237	22.85
Retina . . . . .	109	10.51
Conjunctiva . . . . .	158	15.23
Cornea . . . . .	102	9.82
Congenital malformation . . . . .	20	1.06
Unclassified . . . . .	33	3.18
Glaucoma . . . . .	136	13.11

From this table we learn that the optic nerve and the uveal tract are the parts of the eye disease of which tends most frequently to blindness; after them come the conjunctiva, the retina, and the cornea.

For the purpose of the study of the *development of blindness*, Magnus has arranged his collection of accurately observed cases into two classes,—I., congenital blindness; II., acquired blindness; and the latter class he subdivides into three groups,—1, blindness from primary idiopathic diseases of the eyes; 2, blindness from traumatism; and, 3, blindness from diseases of the eye following upon general diseases of the body.

In addition to his own 770 cases, Magnus<sup>2</sup> has collected from other reliable German sources and tabulated 2528 cases of double-sided blindness, as follows:

<sup>1</sup> Loc. cit., s. 93.

<sup>2</sup> Loc. cit., s. 106.

*Magnus's Table of 2528 Cases of Blindness in Germany.**I.—Congenital Blindness.*

	Cases.	Per Cent.
Anophthalmus and microphthalmus . . . . .	27	1.068
Megalophthalmus . . . . .	11	0.435
Cataract . . . . .	3	0.119
Choroiditis . . . . .	4	0.158
Atrophy of the optic nerve . . . . .	19	0.751
Retinitis pigmentosa . . . . .	19	0.751
Amaurosis from retinal atrophy . . . . .	2	0.079
Anomalies of the cornea . . . . .	5	0.198
Tumors . . . . .	1	0.039
Undetermined forms of amaurosis . . . . .	6	0.237
Total . . . . .	97	3.835

*II.—Blindness due to Idiopathic Diseases of the Eyes.*

	Cases.	Per Cent.
Ophthalmia neonatorum . . . . .	275	10.876
Trachoma and ophthalmia . . . . .	240	9.492
Diphtheritic conjunctivitis . . . . .	9	0.356
Disease of the cornea . . . . .	204	8.068
Irido-choroiditis, cyclitis, iritis . . . . .	224	8.860
Myopic choroiditis . . . . .	24	0.949
Choroiditis, retino-choroiditis . . . . .	28	1.107
Retinitis pigmentosa . . . . .	32	1.266
Hemorrhagic retinitis . . . . .	3	0.119
Neuro-retinitis . . . . .	20	0.791
Detachment of the retina . . . . .	120	4.746
Glaucoma . . . . .	227	8.978
Atrophy of the optic nerve . . . . .	196	7.751
Tumor of the eye or orbit . . . . .	9	0.356
Undetermined . . . . .	85	3.362
Total . . . . .	1696	67.077

*III.—Traumatic Blindness.*

	Cases.	Per Cent.
Direct injuries . . . . .	102	4.034
Unsuccessful operations . . . . .	49	1.938
Injuries of the head . . . . .	7	0.277
Sympathetic ophthalmia . . . . .	114	4.509
Total . . . . .	272	10.758

*IV.—Blindness due to General Diseases.*

	Cases.	Per Cent.
Syphilitic eye-disease . . . . .	12	0.470
Gonorrhœal conjunctivitis . . . . .	23	0.910
Scrofulous eye-disease . . . . .	1	0.039
Irido-choroiditis from meningitis . . . . .	36	1.424
Atrophy or cerebral optic neuritis . . . . .	176	6.961
Spinal optic atrophy . . . . .	59	2.333
Atrophy or optic neuritis after hæmatemesis . . . . .	10	0.396
Atrophy from vomiting without hemorrhage . . . . .	2	0.079
Atrophy after hemorrhoidal bleeding . . . . .	1	0.039
Atrophy after facial erysipelas . . . . .	2	0.079
Atrophy of the insane . . . . .	1	0.039
Atrophy of epilepsy . . . . .	4	0.158
Atrophy after dysentery . . . . .	2	0.079
Nephritic retinitis . . . . .	5	0.198
Diseases of the eye after typhoid fever . . . . .	24	0.949
Diseases of the eye after measles . . . . .	16	0.633

*Magnus's Table.*—Continued.

Diseases of the eye after scarlet fever . . . . .	13	0.514
Diseases of the eye after small-pox . . . . .	56	2.216
Diseases of the eye after various exanthems . . . . .	6	0.235
Diseases of the eye after heart-disease . . . . .	1	0.039
Diseases of the eye in pregnancy or childbed . . . . .	11	0.431
Intoxication amaurosis . . . . .	1	0.039
Blindness from disease of the orbit . . . . .	1	0.039
Total . . . . .	463	18.299

Trousseau<sup>1</sup> has collected the statistics of the Hospice des Quinze-Vingts for a period of ten years, and the record embraces 625 carefully observed cases, tabulated in the order of frequency of their causes, as follows :

*Trousseau's Table of 625 Cases of Blindness in France.*

	Males.	Females.	Total.	Per Cent.
Atrophy of the optic nerve.				
Medullary . . . . .	33	21	54	
Cerebral . . . . .	20	12	32	
Various or undetermined . . . . .	27	16	43	
	80	49	129	20.64
Purulent ophthalmia.				
Congenital . . . . .	15	14	29	
Children . . . . .	35	20	55	
Adults . . . . .	10	7	17	
	60	41	101	16.16
Irido-choroiditis.				
Post-operative . . . . .	20	10	30	
Intra-ocular causes . . . . .	20	8	28	
General causes . . . . .	7	10	17	
	47	28	75	12.00
Glaucoma . . . . .	39	27	66	10.56
Traumatisms				
Various causes . . . . .	23	8	31	
Blasts . . . . .	13	0	13	
Burns . . . . .	8	2	10	
	44	10	54	8.64
Affections of the cornea.				
Diathetic . . . . .	10	11	21	
Variola . . . . .	10	4	14	
Measles . . . . .	4	4	8	
Typhoid fever . . . . .	1	0	1	
	25	19	44	7.04
Detachment of the retina.				
Myopic . . . . .	9	11	20	
Traumatic . . . . .	2	2	4	
Undetermined causes . . . . .	6	7	13	
	17	20	37	5.92
Trachoma . . . . .	19	5	24	3.84
Retinitis pigmentosa.				
Unknown cause . . . . .	11	7	18	
Hereditary . . . . .	4	1	5	
Consanguineous . . . . .	0	0	0	
	15	8	23	3.68

<sup>1</sup> Archives d'Ophthalmologie, 1892, xii. p. 218. Trousseau states that he gives the statistics of 627 cases, but his tables add up only 625 cases.



*Trousseau's Table.—Continued.*

	Males.	Females.	Total.	Per Cent.
Choroido-retinitis . . . . .	12	8	20	3.20
Sympathetic ophthalmia . . . . .	10	4	14	2.24
Myopic sclero-choroiditis . . . . .	8	6	14	2.24
Congenital cataract.				
Without cause . . . . .	6	4	10	
Hereditary . . . . .	3	1	4	
Consanguineous . . . . .	0	0	0	
	9	5	14	2.24
Buphthalmia . . . . .	3	2	5	.80
Optic neuritis . . . . .	2	1	3	.48
Conical cornea . . . . .	0	2	2	.32
Grand total . . . . .	390	235	625	100.00

In order that a comparison may be made with the table of Magnus, we have recast the table of Trousseau as follows :

*Trousseau's Statistics of 625 Cases of Blindness in France.*

	Males.	Females.	Total.	Per Cent.
I.—Congenital blindness.				
Congenital cataract . . . . .	9	5	14	
Buphthalmia . . . . .	3	2	5	
	12	7	19	3.04
II.—Blindness due to idiopathic diseases of the eye.				
Atrophy of the optic nerve . . . . .	27	16	43	
Blennorrhœa purulenta . . . . .	60	41	101	
Irido-choroiditis . . . . .	20	8	28	
Glaucoma . . . . .	39	27	66	
Detachment of the retina . . . . .	15	18	33	
Trachoma . . . . .	19	5	24	
Retinitis pigmentosa . . . . .	15	8	23	
Choroido-retinitis . . . . .	12	8	20	
Myopic sclero-choroiditis . . . . .	8	6	14	
Optic neuritis . . . . .	2	1	3	
Conical cornea . . . . .	0	2	2	
	217	140	357	57.12
III.—Traumatic blindness.				
Injury . . . . .	46	12	58	
Unsuccessful operations . . . . .	20	10	30	
Sympathetic ophthalmia . . . . .	10	4	14	
	76	26	102	16.32
IV.—Blindness due to general diseases . . . . .	85	62	147	23.52

The principal causes of blindness, according to Trousseau's statistics, are, in order of diminishing frequency, as follows :

Atrophy of the optic nerve, Purulent ophthalmia, Irido-choroiditis, Glaucoma, Traumatism, Affections of the cornea, Detachment of the retina, Trachoma,	Retinitis pigmentosa, Choroido-retinitis, Sympathetic ophthalmia, Myopic sclero-choroiditis, Congenital cataract, Buphthalmia, Optic neuritis, Conical cornea.
--	---

This order corresponds in the main with that given by Magnus, who has shown that the ocular diseases most to be feared as causes of blindness are, in order of diminishing frequency,

Atrophy of the optic nerve, Purulent ophthalmia, Trachoma, Glaucoma, Irido-choroiditis,	Affections of the cornea, Detachment of the retina, Traumatism, Choroido-retinitis, Congenital affections.
---	--

In comparing these statistics we do not find absolute agreement in the two series. They unite in showing, however, the extreme harmful frequency, first, of papillary atrophy and of purulent ophthalmia, and, secondly, of glaucoma and of irido-choroiditis.

Trousseau's figures, too, throw some light on the subject of irido-choroiditis and of optic neuritis. Irido-choroiditis often conceals other alterations of the eye; it accompanies cataract or pupillary obstructions which hinder examination of the deeper tissues of the eye; and it may be the result of operative interventions. The investigator is thus reduced to suppositions. The figures indicated, then, should be diminished, and the part subtracted added to other diverse affections, especially to detachment of the retina.

It is evident that more than three of the 627 blind examined by Trousseau had had optic neuritis, but the earlier condition was not easy to establish. Many atrophies of the papilla are evidently due to old neuritis, and these have been tabulated under the headings of their several causes.

The general diseases most fatal to the sight, according to Trousseau, are, first, the nervous diseases, especially tabes, syphilis, and the eruptive fevers of childhood, measles especially favoring the evolution of the scrofulous diathesis.

Congenital diseases do not cause a great number of cases of blindness.

Myopia and the traumatism, aggravated by sympathetic ophthalmia, always remain frequent causes of blindness; and the contagious affections, purulent ophthalmia and trachoma, are responsible for a very large proportion of cases.

Schaefer<sup>1</sup> states that the causes of blindness in Russia, following the grouping of Magnus, were, according to the last census, as follows:

<sup>1</sup> Op. cit., s. 10.

*The Causes of Blindness in Russia.*

	Per Cent.	
	Males.	Females.
I.—Congenital, or blind soon after birth . . . . .	8.	6.7
II.—Blindness due to idiopathic diseases of the eye . . . . .	51.2	55.9
III.—Traumatism . . . . .	1.6	0.8
IV.—Blindness due to general diseases . . . . .	23.9	24.3
Other causes . . . . .	8.7	7.1
Unknown causes . . . . .	6.6	5.2

The only published American statistics dealing with any considerable number of cases are those of Dr. Henry S. Oppenheimer,<sup>1</sup> based upon his examination of the adult blind poor of the city of New York who came before him, as the official examiner of the city, to obtain a grant from the fund divided among the poor blind adults who endeavor to maintain themselves without becoming inmates of public institutions. Oppenheimer's statistics, as published, in many cases relate to the number of eyes rather than to the number of patients, and are therefore not properly comparable with the statistics which have been already cited. His original notes are, unfortunately, destroyed, but he has carefully gone over his figures, and has kindly furnished us with the following revised statistics, which form a basis for comparison with the foreign statistics already cited.

Oppenheimer's statistics are based upon 572 cases, of which 304 were males and 268 females. 226, or 39.58 per cent., were natives of the United States, and 346, or 60.42 per cent., were of foreign birth. Of the latter, 29, or 8.4 per cent., were blind when they arrived in this country, and 51, or 14.78 per cent., became blind within five years after their arrival.

Oppenheimer has classified his cases of blindness under the four heads adopted by Magnus, as follows:

*Oppenheimer's Statistics of 572 Cases of Blindness in the United States.**I.—Congenital Blindness.*

	Cases.	Per Cent.
Retinitis pigmentosa . . . . .	2	
Atrophy of the optic nerve . . . . .	5	
Buphthalmia . . . . .	1	
Congenital cataract . . . . .	8	
Syphilis . . . . .	6	
Total . . . . .	22	3.84

*II.—Blindness due to Idiopathic Diseases of the Eyes.*

	Cases.	Per Cent.
Atrophy of the optic nerve . . . . .	26	
Blennorrhœa neonatorum . . . . .	18	
Blennorrhœa virulenta . . . . .	90	
Blennorrhœa gonorrhœica . . . . .	3	
Cataract, senile . . . . .	47	
Dalrymple's disease . . . . .	1	

<sup>1</sup> Transactions of the American Ophthalmological Society, 1891, vol. vi. p. 156, and personal communication.

*Oppenheimer's Table.—Continued.*

	Cases.	Per Cent.
Detachment of the retina . . . . .	3	
Choroiditis and iritis . . . . .	10	
Iritis . . . . .	5	
Keratitis . . . . .	4	
Glaucoma—		
Eyes not operated . . . . .	19	
Eyes operated . . . . .	12	
Myopia . . . . .	5	
Retinitis . . . . .	1	
Retinitis pigmentosa . . . . .	8	
Trachoma . . . . .	23	
Total . . . . .	275	48.08
<i>III.—Traumatic Blindness.</i>		
	Cases.	Per Cent.
Burns . . . . .	7	
Cataract operations . . . . .	32	
Dislocated lens . . . . .	1	
Explosions (blasts, etc.) . . . . .	44	
Foreign bodies . . . . .	4	
Injuries—		
To eyes direct . . . . .	31	
To head . . . . .	19	
Jequirity . . . . .	1	
Poison-ivy . . . . .	1	
Sunstroke . . . . .	1	
Sympathetic ophthalmia . . . . .	23	
Total . . . . .	164	28.67
<i>IV.—Blindness due to General Diseases.</i>		
	Cases.	Per Cent.
Diphtheria . . . . .	1	
Erysipelas . . . . .	4	
Interrupted menses . . . . .	1	
Malaria . . . . .	1	
Measles . . . . .	19	
Meningitis—		
Cerebral . . . . .	26	
Cerebro-spinal . . . . .	3	
Pertussis . . . . .	2	
Pneumonia . . . . .	1	
Pregnancy . . . . .	1	
Rheumatism . . . . .	2	
Scarlatina . . . . .	12	
Sclerosis (multiple) . . . . .	2	
Syphilis . . . . .	9	
Tobacco-poisoning . . . . .	1	
Tabes . . . . .	4	
Typhoid fever . . . . .	3	
Typhus fever . . . . .	3	
Tumor of brain . . . . .	1	
Variola . . . . .	15	
Total . . . . .	111	19.41

The sexes are represented about equally in all these diseases, except in typhus fever, tabes, multiple sclerosis, and meningitis.

For the purpose of comparison, these statistics bearing on the causation of blindness are grouped in the following table:

*The Causes of Blindness.*

Observer.	Congenital Blindness.	Blindness due to Idiopathic Disease of the Eyes.	Blindness due to Traumatism.	Blindness due to General Diseases.
	Per Cent.	Per Cent.	Per Cent.	Per Cent.
Magnus . . . . .	3.84	67.08	10.76	18.30
Trousseau . . . . .	3.04	57.12	16.32	23.52
Oppenheimer . . . . .	3.84	48.08	28.67	19.41

These combined statistics tend to show that congenital blindness prevails in about the same proportion in Germany, France, and the United States; that blindness from idiopathic diseases of the eye is more frequent in Germany and France and is less often met with in the United States; that blindness from traumatism rises to a high proportion in the United States; and that blindness due to general diseases is more frequently observed in France than in Germany and the United States.

#### I. CONGENITAL BLINDNESS.

This group includes both those cases born into the world blind and those born with the germs of blindness already existing in the eyes, but the process not yet fully completed. Magnus's general table of 2528 cases shows 97 cases of congenital blindness, or 3.83 per cent., which corresponds with the 3.04 per cent. given by Trousseau, the 3.7 per cent. found by Dumont in the large Paris Blind Asylum, and the 3.84 per cent. found by Oppenheimer among the poor of New York City. In the United States at large the proportion appears to be more than double these figures. According to the census of 1890, of a total of 50,411 blind, 4267, or 8.46 per cent., were returned as congenitally blind. The average proportion was 68 per million of population.

In the etiology of congenital blindness, apart from its relation to foetal eye-diseases, the question of the influence of heredity and consanguinity demands consideration. In the eleventh United States census, of 43,326 blind who reported as to blind relatives, 8342, or 19.25 per cent., had such relatives; while of 4156 congenital blind who reported as to relatives, 1608, or 38.7 per cent., had such relatives. The proportion who had blind relatives was about twice as great among the congenital as among the total blind.

*Heredity.*—The diseases of the eye which are most frequently transmitted directly by parents to their offspring are the various malformations: coloboma of the iris and choroid, microphthalmia, aniridia, persistence of the pupillary membrane, congenital cataracts and amblyopias, nystagmus, albinism, and retinitis pigmentosa; and these malformations may be transmitted in the same or like form. Thus, cases are recorded in which a father blind from ophthalmia neonatorum had two children who were microph-

thalmic, and a father blind since infancy in the right eye from irido-cyclitis had a son whose right eye was microphthalmic, and there can be no doubt that there existed a connection between the disease of the father and that of the child, since Deutschmann has obtained similar results from experiments upon rabbits.

Heredity most often occurs when the parents have been attacked with eye-disease, either congenital or acquired, in infancy, and it is not necessary that the progenitor himself shall have an eye-affection to influence the eyes of his offspring ; it is sufficient if he transmit the germ of degeneration.

The influence of heredity on myopia is very marked. Thus, in three hundred and twenty myopic children, Motais<sup>1</sup> found it to be hereditary in two hundred and sixteen families, or 67.5 per cent. In twenty families in which both parents were myopic, with sixty-two children, forty-seven, or nearly 76 per cent., were myopic. Motais finds that hereditary myopia is more progressive than acquired myopia, that it more rapidly reaches a high degree, and that the complications are more frequent and set in earlier ; in fine, that hereditary myopia is more grave than acquired myopia, and consequently demands a more vigorous treatment. Motais further holds that acquired myopia tends to become hereditary, and, if care is not taken, acquired myopia multiplied by heredity will become more and more frequent as education becomes more universal, even among girls, and that the intermarriage of persons with normal eyes, uninjured by study, will become more and more rare.

Hence we see that myopia is most often hereditary, that it develops and is aggravated at school, and that hereditary myopia should be more carefully guarded against than acquired myopia.

The constitutional diseases of parents which predispose their infants to ocular affections are especially tuberculosis, serofula, and syphilis.

The *tubercular lesions* of the eye are rare, and it is not necessary to dwell upon their gravity, or upon the importance of those affected with tubercle abstaining from marriage.

The *serofulous* eye-diseases of childhood are more common. Phlyctenular conjunctivitis, blepharitis, and keratitis in all its forms—affections which are serofulous in character—are frequently observed, and their influence upon sight can be most injurious because of the opacity of the cornea which they are apt to cause. Trousseau found that of forty-four cases of blindness due to keratitis, twenty-one were of serofulous origin. In these cases prevention can do much. The serofulous child should be immediately placed under the best hygienic conditions and special attention given to its nutrition.

Of all hereditary affections liable to attack the eye, *syphilis* is the most important. In two hundred and twelve hereditary syphilitics, Fournier has found the eye affected in one hundred and one. The disease may

---

<sup>1</sup> Quoted by Trousseau, *Hygiène de l'Œil*, p. 134.

declare itself almost from birth, but according to Trousseau it is most often between three and twenty-five years that it appears, with the maximum of frequency between seven and eleven years.

The most frequent of these syphilitic affections are interstitial keratitis, iritis, and choroido-retinitis, and if unrecognized, badly treated, or treatment too long deferred, they may lead to blindness.

The limitations under which a syphilitic may marry have been well defined by Fournier,<sup>1</sup> and it may here be added that if during pregnancy the mother shows any syphilitic symptoms she should be treated in the interest of the infant, and the eyes of the infant should be kept under careful observation during the whole period of childhood.

There can be no *prophylaxis*, properly so called, in cases of inherited diseases, and there are no means of preventing the transmission from parents to offspring of certain ocular affections; but persons suffering from eye-disease, either congenital or acquired at an early age, should be informed that their eye-disease may be transmitted to their offspring. Magnus has investigated fourteen instances of married couples in whom one or both were either born blind or became so at an early age; of the thirty-four children begotten of these marriages, eight, or 23.5 per cent., were either blind or weak-sighted.

*Consanguinity*.—From a careful investigation of this subject, reinforced by the labors in the same direction of G. Darwin, Huth, Lanery, Fieuzal, and Ferret, Trousseau<sup>2</sup> has reached the conclusion that, independent of heredity, consanguinity does not play any rôle in the production of blindness. Taking congenital cataract, retinitis pigmentosa, and albinism as types of the affections which there has been a marked tendency to ascribe to consanguineous origin, Trousseau has given to them a careful study. He finds that in twenty cases of congenital cataract, in eleven neither heredity nor consanguinity existed, in five heredity was manifest, and in three consanguinity appeared, at first, to play the principal causative part, but further investigation soon showed that heredity was a preponderating factor. In one case the investigation was insufficient. In eleven cases of retinitis pigmentosa, four were without evident cause, five were hereditary, and two were apparently of consanguineous origin, but closer investigation showed them to be clearly of hereditary origin. Of three cases of albinism, one was of obscure origin, one was hereditary, and one was apparently consanguineous, but was in reality of hereditary origin. As the result of his investigations, Trousseau holds that, without the intervention of heredity, consanguinity is powerless to produce ocular lesions. It cannot cause any morbid state without the materials which heredity furnishes to it, and hence, from the hygienic point of view, there is no good reason to interdict consanguineous marriages when the visual organs of the contracting parties are sound and

<sup>1</sup> Syphilis et Mariage, Paris, 1880.

<sup>2</sup> Loc. cit., p. 139.

well formed. Magnus, too, holds that we have no proof of the influence of consanguinity in causing blindness.

## II. BLINDNESS DUE TO IDIOPATHIC DISEASES OF THE EYE.

This group comprises 67.08 per cent. of Magnus's collected German cases, 57.12 per cent. of Trousscau's cases observed at the Hospice des Quinze-Vingts, and 48.08 per cent. of the cases examined by Oppenheimer in New York.

*Ophthalmia neonatorum* is, with the single exception of atrophy of the optic nerve, the most frequent cause of blindness. The Committee of the Ophthalmological Society of the United Kingdom<sup>1</sup> has reported that from thirty to forty-one per cent. of the inmates of four blind asylums in Great Britain owed their blindness to it. Reinhard, quoted by Magnus,<sup>2</sup> found, in 1876, that in twenty-two German blind asylums, 658 cases out of a total of 2165, or thirty and a half per cent., were blind from this disease. The British Royal Commission on the Condition of the Blind estimated that there were about 7000 persons in the United Kingdom who had lost their sight from this disease, or about twenty-two per cent. of the entire blind.

Of the 50,568 blind persons in the United States, according to the census of 1890, Burnett<sup>3</sup> estimates that at least thirty per cent. have become so from *ophthalmia neonatorum*.

Fuchs<sup>4</sup> gives the following statistics from six German lying-in hospitals as to the injury to the sight resulting from attacks of *ophthalmia neonatorum*:

*Injury to Sight from Ophthalmia Neonatorum.*

	Cases of Blennorrhœa.	Opacity of Cornea.	Blindness of One Eye.	Blindness of Both Eyes.	Percent- age of Injured Eyes.
Berlin Charité . . . . .	213	2	2	?	1.9
Munich Lying-in Hospital . . . .	123	1	2	1	2.4
Dresden Lying-in Hospital . . . .	1378	38	15	4	3.8
Stuttgart Lying-in Hospital . . . .	538	13	12	1	4.6
Vienna Foundling Hospital . . . .	1347	112	171	42	21.0
Prague Foundling Hospital . . . .	300	105	32	?	45.7

These statistics show a very striking increase in the percentage of blind cases in foundling hospitals over lying-in hospitals, the reason for which is that the cases are generally admitted into foundling hospitals in a very neglected state, when the cornea is already implicated, and under such circumstances treatment often comes too late to save the sight. Hence the proportion of cases in foundling hospitals approximates to that in ophthal-

<sup>1</sup> Transactions, 1884, p. 33.

<sup>2</sup> Loc. cit., s. 165.

<sup>3</sup> The Century, December, 1892.

<sup>4</sup> Die Ursachen und die Verhütung der Blindheit, Wiesbaden, 1885, s. 120.



mic hospitals, where a larger proportion of the severe and neglected cases are seen than of the mild ones.

As regards the percentage of cases in which blindness of *both* eyes results from ophthalmia neonatorum, the statistics of the Vienna Foundling Hospital and of Hirschberg<sup>1</sup> and Emrys Jones<sup>2</sup> closely correspond.

*Blindness from Ophthalmia Neonatorum.*

	Cases of Blennorrhœa.	Blindness of Both Eyes.	Per- centage.
Vienna Foundling Hospital . . . . .	1347	42	3.1
Hirschberg . . . . .	200	6	3.0
Emrys Jones . . . . .	420	16	3.8

On the other hand, Horner<sup>3</sup> had not a single case of blindness in one hundred and eight cases of ophthalmia.

For the reasons already stated, it is not possible to draw exact conclusions from these percentages, as the data are too divergent, owing to the variation in frequency of ophthalmia in different countries and the difference in the material investigated. Thus, in the blind asylums of Germany, Austria, Denmark, and Holland, Reinhard obtained a percentage of blennorrhœic blindness of forty per cent., whilst in nine German eye hospitals Magnus obtained a percentage of ten and eight-tenths, and in the entire population of the Duchy of Brunswick, Fuchs<sup>4</sup> gives a percentage of twenty-eight.

The proportion given by the blind asylums is too high, because their inmates are chiefly the young, among whom ophthalmia is proportionally frequent. On the other hand, in the eye hospitals these cases appear less frequently, because they have come to regard their blindness, with which they have been afflicted since infancy, as irremediable. Lastly, the census statistics of the blind of an entire country are too superficial and liable to too many errors to be trustworthy.

While ophthalmia neonatorum is one of the chief causes of blindness, it at the same time happily presents one of the most gratifying problems in preventive medicine, since with appropriate treatment infection can be prevented in a large majority of cases ; or, with our present knowledge of its proper method of treatment, if it do occur, we can, with reasonable certainty, cure the disease before blindness ensues. Glascott<sup>5</sup> has estimated that nine-tenths of the cases of blindness from ophthalmia neonatorum might have been prevented by simple cleanliness and the early application of proper remedies, and Magnus calculates that Prussia alone could have

<sup>1</sup> Beiträge zur praktischen Augenheilkunde, 1876, s. 6.

<sup>2</sup> Manchester Medical Society, February, 1881.

<sup>3</sup> Handbuch der Kinderkrankheiten, Bd. v., th. ii., s. 262.

<sup>4</sup> Loc. cit., s. 122.

<sup>5</sup> Fifty-third Annual Report of Henshaw's Blind Asylum, Manchester, England.

saved two millions of dollars a year by the efficient enactment of such prophylactic measures against this disease.

In Germany special precautions are now taken against the spread of this disease, and to that end midwives are expressly prohibited by law from treating any affection of the eyes or eyelids, however slight. On the appearance of the first symptom they are required to represent to the parents or others in charge that medical assistance is urgently required, or, if necessary, they are themselves to report to the local authorities and the district doctor. Neglect of these regulations makes them liable to punishment.

In the United States within the last few years the States of New York, Rhode Island, Maine, Minnesota, Ohio, Maryland, Missouri, Massachusetts, Connecticut, Pennsylvania, and New Jersey have enacted laws requiring that, should one or both eyes of an infant become inflamed or swollen or reddened at any time within two weeks of its birth, it shall be the duty of the midwife or nurse having charge of such infant to report in writing, within six hours, to the health officer, or some legally qualified physician of the city, town, or district in which the parents of the infant reside, the fact that such inflammation or swelling or redness of the eyes exists. The penalty for failure to comply with the law is made a fine not to exceed two hundred dollars, or imprisonment not to exceed six months, or both.

The prophylaxis should have regard to the maternal passages as well as to the infant's eyes, and should cover the period during delivery and after birth, and it has been treated of in detail elsewhere in this work. As the disease is highly contagious from infant to infant and from infant to adult, it is necessary to isolate those who are attacked, and to instruct their attendants concerning the precautions they should take to prevent the introduction of the infectious matter into the eye. All contaminated articles, such as dressings, bandages, and the like, should be burned. Sponges should never be used, but in their stead absorbent cotton, which after use should be burned. All instruments used should be carefully disinfected in a strong carbolic solution and then subjected to heat. Towels used by infected persons should be boiled before being used again.

The remarkable influence of the very simplest antiseptic precautions taken at birth in the prevention of ophthalmia neonatorum is shown by the statistics of the Leipzig Lying-in Hospital. Under the old method of treatment the percentage of cases of ophthalmia was for the six years preceding 1880, 10.48, and for the first five months of 1880 it was 7.6. The new treatment was introduced June 1, 1880, and in the following six months the percentage fell to 0.5, and since then, according to Magnus, six hundred infants have been born in the hospital without the occurrence of a single case of ophthalmia.

*Acute blennorrhœa of adults*, like that of new-born infants, is an infectious disease. The source of infection is to be found either in the genital organs or in another blennorrhœic eye, and the infection is usually intro-

duced into the eye by means of the finger. But, notwithstanding the frequent opportunities for infection, it is not a very common disease. According to Hirschberg, it forms 1.18 per thousand, and according to Fieuzal, not quite 0.5 per thousand, of all eye-diseases. In one thousand blind eyes Cohn found twenty-six, or 2.6 per cent., which were lost by gonorrhœal conjunctivitis. Trousseau found the percentage at the Quinze-Vingts to be 2.7, while Oppenheimer's statistics for the city of New York give but a little over one-half of one per cent.

The acute blennorrhœa of adults is a much more dangerous affection than that of the new-born, and in severe cases it is not always possible to prevent the loss of sight of the eye. Its prophylaxis consists in the observation of the same precautions as have been indicated for the prevention of the spread of ophthalmia neonatorum, and, in addition, as one of the most common causes of this disease in the adult is the transfer of matter from a blennorrhagic urethritis, a gonorrhœic patient should be extremely careful never to touch his eye with a finger that could be in any way infected with the gonorrhœal discharge, and all dressings used about the genital organs should be burned.

*Granular ophthalmia* is a frequent cause of blindness. Cohn found 1.7 per cent. of his 1000 cases of total blindness were due to it; Magnus, among 707 cases, found 2.2 per cent.; Daumas, among 1178 cases, 5.4 per cent.; Carreras-Arago, among 395 cases, 9.1 per cent.; and Oppenheimer, among 572 cases, 4 per cent. It is a disease which is very infectious, and occurs especially among those who are crowded together in badly ventilated, badly lighted, and damp rooms and workshops. It has been at times epidemic in large schools, in armies, and in the naval marine. It has been incorrectly stated to have been first introduced into Europe by Napoleon's army on its return from Egypt, where it then was and still is very prevalent.

The number of cases of blindness in Ireland attributed to ophthalmia was :

In 1861, 1962, or one in every 2,955 of the population.

In 1871, 1642, or one in every 3,296 of the population.

In 1881, 523, or one in every 9,894 of the population.

In 1891, 378, or one in every 12,446 of the population.

It would thus appear that in Ireland this disease has been reduced to a comparatively low figure. As it chiefly prevails there among those who are located under the extreme unsanitary condition usually associated with poverty, and as a considerable number of this class always become inmates of workhouses, a continuous flow of cases of ophthalmia was admitted to the workhouses, and, the disease being of an infectious character, great difficulty was experienced in preventing its spread among the workhouse inmates. The difficulty has now been to a large extent overcome by improved sanitary conditions, and the number of workhouse inmates affected with ophthalmia has been steadily diminishing with each decade, and is now very limited.

Granular ophthalmia is usually communicated by the use of various objects, such as sponges, dressings, towels, and other toilet articles, and by washing in water which had been previously used by a person suffering from this eye-affection. It is preventable under proper sanitary conditions, and it is stated that no case of loss of eyesight from this disease occurred among the British troops during their late occupation of Egypt.<sup>1</sup>

*Diphtheritic conjunctivitis*, as a rule, attacks children under ten years of age, and it is chiefly when diphtheria is epidemic that a conjunctivitis exhibits a tendency to become diphtheritic. Apart from the danger to life from the general illness, it is a disease very dangerous to the eyes. According to the statistics of the blind given by Cohn, diphtheria was the cause in 0.3 per cent., and Magnus, in his 2528 collected cases of double blindness, found 0.356, or practically the same percentage.

Horner<sup>2</sup> states that under v. Graefe, out of forty cases, nine eyes; under Hirschberg, out of ninety-four cases, thirty-five eyes; and under Jacobson, out of twenty-two cases, five eyes, were *totally* blinded, whilst many eyes were much injured.

The prophylaxis consists in observing the same precautions in preventing the introduction of the infectious matter into the eye as are indicated in other forms of infectious ophthalmia.

*Diseases of the cornea*, in Magnus's table, yield 8.07 per cent. of cases of double blindness. But this percentage should not be accepted as due to idiopathic corneal disease. Included are cases due to constitutional dyscrasia, especially scrofula, and the mechanical injuries incident to certain occupations. The former have, in turn, diminished the percentage credited to scrofula in the same table.

*Diseases of the uveal tract* include iritis, irido-choroiditis, and cyclitis, and in Magnus's table give 8.86 per cent. of cases of double blindness. Chronic irido-choroiditis (irido-choroiditis serosa) is often met with in persons over forty years of age. Many of the cases may be arrested by iridectomy, but others will continue their course uninfluenced by operative interference, and lead to blindness. According to Magnus, of blind persons between forty-five and sixty years of age, 15.5 per cent. have lost their sight by disease of the uveal tract, and a considerable proportion of these have been contributed by irido-choroiditis.

There is no prophylaxis against chronic irido-choroiditis.

*Detachment of the retina* is the most frequent and of the highest importance of the idiopathic diseases of the retina, and constitutes 4.75 per cent. of the cases in Magnus's collected table. In the forty-nine cases of blindness from detachment of the retina personally observed by Magnus, twenty-one were certainly more or less highly myopic from youth; and in the other twenty-eight, the reports of the early condition of the refraction were too

---

<sup>1</sup> Report of the Royal Commission on the Blind of the United Kingdom.

<sup>2</sup> Quoted by Fuchs, *loc. cit.*, s. 176.

uncertain to draw any safe conclusions from them. Of the aforementioned twenty-one, Magnus holds that in nineteen there was proof that the myopia was congenital, and not the result of excessive fatigue of the eye at school.

Of the forty-nine cases, in thirteen the detachment of the retina in the second eye followed so closely upon that in the first that the interval could not be accurately determined. Of the remaining thirty-six, in which there was a longer or shorter interval before the sight of the second eye was lost, in twenty-eight the sight was lost by detachment of the retina in each eye, and in the remaining eight cases one eye in each was lost at an earlier period by some other affection.

The length of the interval which elapsed before the appearance of detachment of the retina in the other eye varied from one year to thirty. Of the twenty-eight cases, the right eye was the first affected in nineteen, or 67.86 per cent., and the left eye in nine, or 32.14 per cent. This greater tendency of the right eye to be attacked first is confirmed by Magnus's study of one hundred and nine cases of one-sided idiopathic detachment of the retina, of which in sixty-three, or 57.80 per cent., the right eye, and in forty-six, or 42.20 per cent., the left eye, was first affected,—a percentage which also closely corresponds with that found by Stolte in thirty-eight cases examined at the eye clinic at the University of Greifswald. On the other hand, Landesberg, in thirty-one cases, found the right eye affected in fifteen and the left in sixteen cases.

*Glaucoma* gives a percentage of 8.978 cases in Magnus's collected table, of 10.84 in Oppenheimer's, and of 10.56 in Trousseau's table. As to the age at which blindness from glaucoma occurred, the ninety-seven cases personally observed by Magnus furnish the following information :

Two lost vision at twenty years of age.  
 Five lost vision between thirty and forty years of age.  
 Twelve lost vision between forty and fifty years of age.  
 Twenty-four lost vision between fifty and sixty years of age.  
 Forty-five lost vision at over sixty years of age.  
 In nine cases the age could not be ascertained.

Fifty-eight of the cases were females and thirty-nine males.

Of these ninety-seven cases, ninety-three lost their sight in both eyes by glaucoma, and four lost their sight in one eye from some other disease. Of the ninety-three, in seventy-three the interval which elapsed between the loss of sight in one eye and then in the other could not be ascertained with any degree of certainty. In the remaining twenty cases, in four the interval was one year ; in three, two years ; in two, three years ; in four, four years ; in three, five years ; in one, six years ; in one, ten years ; in one, eleven years ; in one, eighteen years.

*Idiopathic atrophy of the optic nerve* yields a percentage of 7.751 cases in Magnus's general table.

*Tumors of the eye* or of its surrounding tissues are often the cause of

unilateral blindness, but they are rare factors in the production of double-sided blindness. In Magnus's collected table they constitute but 0.356 per cent. of the cases.

### III. BLINDNESS DUE TO TRAUMATISM.

Traumatism is a very frequent cause of blindness. Fieuzal<sup>1</sup> found among three hundred blind persons in the Hospice des Quinze-Vingts 9.8 per cent. of blindness from injuries, and Trousseau's later statistics of the same institution give a percentage of 16.32, which is 5.5 per cent. larger than that given by Magnus,—viz., 10.76 per cent. Among the blind in Austria, the cases due to injuries amounted to 7.9 per cent.

In the United States, 28.67 per cent. of Oppenheimer's cases were due to traumatism, and, according to the eleventh census, nearly twenty per cent. of the cases of blindness from known causes were due to injury, the proportion being much greater among the males (275.93 per thousand) than among the females (97.21 per thousand).<sup>2</sup> Of the 7134 in whom the blindness was due to injury, 117 were under one year of age, 356 were between one and five years of age, 516 were between five and ten years, 903 were between ten and twenty years, 3024 were between twenty and fifty years, 1865 were at the age of fifty years and upward when the injury was received, while for 353 the age when the injury occurred was unknown.

The cases of blindness of one eye from injuries are, of course, much more frequent; according to Cohn, they constitute 24.2 per cent. of all cases of one-sided blindness. In the United States the proportion is much higher, reaching 44.06 per cent., according to the last census. Many of these unfortunates are in constant danger of losing the sight of their sound eye by sympathetic inflammation. According to the Royal Commission on the Condition of the Blind in the United Kingdom,<sup>3</sup> total blindness ensues in from 4 to 4.5 per cent. of all injuries to one eye. Glascott<sup>4</sup> states that at least one-half of persons blinded by injury to one eye lose the other from sympathetic disease. Sympathetic inflammation is, therefore, a constant menace to the sight of the uninjured eye, and early surgical treatment of the injured eye is of the utmost importance, with a view to preserving the sight of the sound eye.

Blindness comes on from either direct injury to both eyes or the injury of one eye setting up sympathetic inflammation in the other. According to Magnus, the former comprises 4 per cent. and the latter 4.5 per cent. of all cases of blindness. Direct injuries to the eyes in males are chiefly accidents occurring while at work, whereas in women and children they are for the most part due purely to accident or carelessness, or are produced by wilful violence.

<sup>1</sup> IV. Congrès d'Hygiène, i. p. 218.

<sup>2</sup> See page 431.

<sup>3</sup> Loc. cit.

<sup>4</sup> Paper read at the annual meeting of Henshaw's Blind Asylum, 1886.

Injuries by animals and by lightning are given in the Irish census returns for 1891 as responsible for thirteen and seven cases respectively.

*Injuries by foreign bodies* constitute the majority of traumatism of the eye. They are most frequently met with among workers in metal and stone. When the foreign bodies are large and strike the eye with force, they perforate its membranes and penetrate into the interior of the eye. Eyes thus injured are generally lost; and, moreover, when but one eye is injured, it is apt to give rise to sympathetic inflammation in the other eye.

The accidents most frequently observed are burns, foreign bodies, punctures or cuts, rupture of the membranes, and traumatic cataract. According to Glascott,<sup>1</sup> burns from fire, acids, corrosives, and lime may be held to cause twelve per cent. of all injuries, and accidents from flying pieces of stone or chips of metal fifty-eight per cent. In weaving-mills, accidents from shuttles flying out of the loom formerly were very frequent, and generally of a very destructive character, but of late years their frequency has been markedly diminished by the introduction of shuttle-guards.

Coccius<sup>2</sup> gives the following list of artisans, not including miners, in whom injuries to the eye incurred in their occupations were observed by him during the years 1868 and 1869. They are arranged in the order of diminishing frequency as follows :

Locksmiths . . . . .	156	Millers . . . . .	18
Handicraftsmen . . . . .	67	Carpenters . . . . .	14
Masons . . . . .	43	Stone-masons . . . . .	8
Smiths . . . . .	23	Metal turners . . . . .	6
Machine-makers . . . . .	22	Total . . . . .	357

The investigations of Cohn<sup>3</sup> are very interesting as showing the dangers to which the eyes of metal-workers are subjected. He found that every one of the 1283 workers in metal examined by him suffered two or three times a year from injury to the eyes. About one-half of those injured (633) were compelled to obtain medical aid. Of these, thirty-six, or 5.7 per cent., were partially deprived of sight, and sixteen, or 2.5 per cent., lost the sight of one eye entirely. A careful examination of the cornea of one of these workmen will often show about a dozen small point-like opacities in the cornea which have been caused by the impact of foreign bodies.

The use of protective spectacles would greatly diminish the liability to accidental injury of the eyes in some trades, but workmen generally refuse to wear them because they think the spectacles interfere with their acuity of vision. Glass is certainly open to the objection that in case of accident it is liable to splinter and penetrate the eye which it is intended to protect; but even eye-protectors made of fine brass wire, or of mica, it is difficult to induce artisans to wear.

<sup>1</sup> Loc. cit.  
<sup>2</sup> Quoted by Magnus, loc. cit., s. 197.  
<sup>3</sup> Cited by Fuchs, loc. cit., s. 185.

*Injuries by blows, thrusts, pricks, etc.*, are generally caused by accidents which cannot be foreseen or avoided, while most of the injuries that are purposely inflicted belong to this class.

*Injuries from explosive substances* are generally a combination of burn and injury by a foreign body, such as grains of powder, particles of the exploded material, rock, sand, coal, etc., and are most frequent in the mining districts. Of fifty-four cases of traumatic blindness reported by Trousseau, thirteen, or 24 per cent., were caused by mine explosions; and Layet<sup>1</sup> reports that at Liège, of one hundred and six blind from wounds, sixty, or 56.6 per cent., were from coal-mine explosions.

Injuries by gunpowder are usually much more dangerous than simple injuries by foreign bodies, not only on account of their greater severity, but also because they generally involve both eyes. Children furnish a large number of the injuries caused by explosives, as the result of careless playing with fire-arms or with dangerous toys, such as percussion-cap toy pistols, fulminating preparations, etc.

*Injuries received in War.*—The following table, quoted by Fuchs<sup>2</sup> from Reich, shows the frequency of injuries of the eye in proportion to the total wounded. The larger proportion observed in the Armenian war is because slight wounds were noted, which was not the case in the statistics of the other wars.

*Injuries of the Eye received in War.*

	Number of all the Wounded.	Injuries to the Eye.	Per Cent.
War of the Rebellion . . . . .	408,072	1190	.29
Franco-German war . . . . .	75,321	464	.61
Armenian war (1877-78) . . . . .	13,091	290	2.21

*Unsuccessful operations* are responsible for 1.938 per cent. of the cases in Magnus's general table. This percentage is probably higher than now obtains under the modern technique of cataract operations, and it is to this class of operations that most of the cases belong.

*Blindness from Injuries to the Skull.*—Blindness sometimes ensues on injuries which do not affect the eye directly, but the skull. Such cases, according to Magnus, constitute 0.277 per cent. of all cases of blindness. Injuries to the skull lead to blindness in very various ways. In some cases Berlin<sup>3</sup> has demonstrated that fractures of the bone, especially in the optic canal, are present, which cause bruises and laceration of the optic nerve.

*Traumatic sympathetic ophthalmia.*—Sympathetic blinding of one eye from injury of the other was the cause of 4.509 per cent. of cases in Mag-

<sup>1</sup> Quoted by Trousseau, loc. cit., p. 120.

<sup>2</sup> Loc. cit., s. 187.

<sup>3</sup> Quoted by Fuchs, loc. cit., s. 189.



nus's table. Of the thirty-four cases personally observed by Magnus, there were sixteen between one and fifteen years of age, six between fifteen and thirty, seven between thirty and forty-five, one between forty-five and sixty, one between sixty and seventy. In three cases no reliable information could be obtained as to the age. Twenty-three of the cases were males and eleven females. The large proportion of cases occurring in childhood and among males stands in natural relation with the larger proportion of cases of injury occurring at the same period and among the male sex. As to the time which elapsed before sympathetic blinding of the second eye occurred, Magnus found that in one-half of the cases the interval was less than a year, and that in fourteen cases it was half a year or less. The shortest period was four weeks, and the longest twenty-eight years. His experience agrees with that of most observers, that the danger of the appearance of sympathetic inflammation is greatest during the first week.

#### IV. BLINDNESS DUE TO GENERAL DISEASES.

General or systemic diseases were responsible in Oppenheimer's table for 19.41 per cent., in Magnus's general table for 18.3 per cent., and in Trousseau's table for 23.52 per cent. of all the cases of blindness.

*The brain* is by far the most important of all the organs of the body in the causation of blindness. To it are ascribed 7.46 per cent. of the cases from known causes tabulated in the last United States census. According to Magnus, it is responsible for 46.8 per cent. of his collected cases due to systemic disease. Of these, 39 per cent. were due to disease of the brain and its membranes causing changes in the optic nerve and the retina, and manifesting themselves in atrophy of the optic nerve or optic neuritis. In the remaining 7 per cent. the blindness was due to a direct transmission of the meningitic process to the eyeball, especially to the uveal tract, and blindness ensued from irido-choroiditis. According to Mauthner, intracranial diseases give rise to at least four-fifths of the cases of optic neuritis.

Affections of the retina and optic nerve in meningitis were found by Allbutt in thirty-eight cases twenty-nine times, by Heinzl in forty-one cases forty-one times, by Bouchut in fifty-nine cases fifty-seven times. The changes observed in these cases were generally a slight hyperæmia or inflammation of the retina and optic nerve, but in some cases they were so severe as to lead to blindness. It is probable that in many of the cases in which atrophy of the optic nerve comes on after measles, scarlatina, dysentery, and typhoid fever, the eye-affection is due to a complicating meningitis.

The chronic diseases of the nervous system are those which most frequently lead to affections of the globe of the eye. Cerebral tumors are accompanied by intense optic neuritis with circumpapillary hemorrhages.

*The Spinal Cord.*—Disease of the spinal cord was responsible for 12.74 per cent. of the cases due to general diseases in Magnus's table. A large proportion were cases of atrophy of the optic nerve leading to blindness

resulting from tabes, which has a special predilection for the eye, and Leber and Graefe estimate that from 26 to 30 per cent. of all cases of optic atrophy depend upon this disease, which is a larger percentage than that given by Magnus. On the other hand, Cyon found that in two hundred and three cases of tabes dorsalis blindness occurred in twenty-seven, or 13.3 per cent. Chareot has pointed out that optic atrophy often precedes the typical phenomena of tabes, and may even make evident its onset. In other cases it may not come on until after the affection of the gait is marked.

Atrophy of the optic nerve is sometimes found with insular sclerosis and lateral sclerosis of the spinal cord; and in general paralysis of the insane, although spinal disease is not always present, atrophy of the papilla frequently occurs.

*The Vascular System.*—Disease of the vascular system was the cause of 2.59 per cent. of the cases due to systemic disease in Magnus's table. Of these, eleven were due to hemorrhage and one to embolism of the central artery of both retinae. Vascular disease leads to blindness by embolism or thrombosis of the retinal vessels. Such cases—more especially in both eyes, however—are very rare. On the other hand, retinal hemorrhages, with or without retinitis, which seriously injures the sight, are not uncommon, and are also caused by changes in the retinal vessels. Magnus reckons among these cases of blindness caused by neuro-retinitis after great loss of blood. Hemorrhages from the stomach, bowels, or uterus are capable of giving rise to serious and incurable blindness, but the connection between the loss of blood and loss of sight in these cases is not yet clearly made out.

*The digestive system* was responsible for only four cases, or 0.86 per cent., of the systemic cases in Magnus's table. Two of these were due to a dysentery which led to the development of optic atrophy, and the two remaining cases were due to a violent vomiting causing atrophy of the optic nerve.

*The uropoietic system* gave twenty-eight, or 6.05 per cent., of the cases due to systemic disease. Twenty-three of these cases were due to gonorrhœal blennorrhœa, and five to albuminuria. Two of the latter were in pregnant women. Omitting the twenty-three cases of gonorrhœal blennorrhœa, the propriety of including which here is doubtful, the cases from albuminuria would be but 1.07 per cent.

*Diseases of the Sexual Organs.*—Neuritis resulting in partial or complete blindness has sometimes been observed as the result of disturbance of the menstrual function, and in various diseases of the uterus.

*The connective tissue and cutaneous system* gave but three cases, or 0.65 per cent., of Magnus's cases due to general diseases. Two of these were cases of atrophy of the optic nerve consequent upon facial erysipelas, and one was a case of atrophy following upon orbital inflammation.

Chronic skin disease exercises a more or less important influence on sight

by promoting the formation of cataract. Atrophy of the optic nerve, too, sometimes seems to be developed by such a cause, and Mooren describes<sup>1</sup> the case of a child in whom blindness from optic atrophy was due to a chronic skin affection of the head, and he considers chronic meningeal hyperæmia as a pathogenic connecting link between head-eruption and optic-nerve atrophy.

Lepra is responsible for a small proportion of cases of blindness. According to Danielsen,<sup>2</sup> out of one hundred and twenty-five leprous patients, eighty-seven, or 69 per cent., had eye-disease, which often results in blindness from opacity of the cornea or from the formation of leprous tubercles in the cornea and sclera, which terminate in shrivelling of the eyeball. Hence in countries where leprosy prevails a certain proportion of the cases of blindness is due to this cause. Thus, in Norway, Professor Hjort, of Christiania, found, among two hundred and eighty-nine cases of blindness, that seven, or 2.4 per cent., were due to this disease; and Pedraglia<sup>3</sup> found in twenty-six lepers, eight, or 30.77 per cent., with leprous eye-disease.

*The acute infectious diseases* gave one hundred and fifteen cases, or 24.8 per cent. of all the cases from general diseases in Magnus's table. They were distributed as follows:

Small-pox, 12.10 per cent.	Scarlet fever, 2.81 per cent.
Typhoid fever, 5.18 per cent.	Other exanthems, 1.30 per cent.
Measles, 3.46 per cent.	

In acute febrile diseases the eyes are much more frequently affected than is commonly supposed. Owing to the gravity of the general disease, the local affection of the eye is very apt to be overlooked, especially when it affects the deeper parts. As the patient makes no complaint of disordered vision, as a rule, no careful examination of the eye is made. If the patient recover, the slighter affections of the eye generally also recover spontaneously, and so pass unnoticed.

Eye-complications are liable to appear at any time in the course of the disease, but they most frequently occur during convalescence, and they have much in common. At the period of invasion of the eruptive fevers there exists a simple conjunctivitis, which may become catarrhal or phlyctenular, and the cornea may become affected; but this occurs more often during convalescence, when a phlyctenular or ulcerous keratitis may develop, and sometimes a true abscess, all of which may result in a considerable diminution of visual power, or even in its entire loss. In all the eruptive fevers iritis or irido-choroiditis may supervene, but affections of the uveal tract are much less frequent than those of the conjunctiva or cornea.

In the comatose period of grave affections the patient often lies for

<sup>1</sup> Ophthalmologische Mittheilungen aus dem Jahre 1873, s. 93.

<sup>2</sup> Quoted by Fuchs, loc. cit., s. 12.

<sup>3</sup> Morphötische Augenkrankung, K. M. f. A., x. s. 65.

several days partially or completely unconscious, with eyelids half open, exposing the lower third of the cornea, which soon becomes covered with a yellow, dried secretion which, upon removal, exhibits the cornea beneath dry, lustreless, dim, or even ulcerated. The prognosis in such conditions is most grave. Should he recover, however, he may have dense cicatrices in the cornea, or he may lose one or both eyes completely. This keratitis was formerly regarded as the effect of depressed innervation, and designated as neuro-paralytic; but now, owing especially to the researches of Feuer,<sup>1</sup> it is known that this form of keratitis is the consequence of the drying of the exposed cornea, and hence he called it keratitis xerotica. This affection may be prevented by covering the eye with a light compressive bandage, or by closing the lids by means of narrow strips of gauze and collodion so soon as the first signs of the drying process show themselves.

*Small-pox* was responsible for 1.41 per cent. of the cases of blindness from known causes tabulated in the eleventh United States census, for 2.216 per cent. of all the cases in Magnus's general table, and, according to Schaefer,<sup>2</sup> for 11.9 per cent. of the cases included in the last Russian census.

The census returns of Ireland show a steady diminution in the number of cases of blindness from small-pox. The census of 1871 gave 526 cases; that of 1881, 359; and that of 1891, 221 cases. This is due not only to the influence of vaccination, but also to the fact that ophthalmia has diminished in frequency and severity. It is a peculiarity of the small-pox eruption to attack most severely the more vascular parts; hence an eye affected with ophthalmia is much more liable to the attack of the small-pox eruption than the healthy eye.

The following table by Fuchs<sup>3</sup> gives an idea of the frequency with which eye-disease of some form, including hypopyon keratitis, appears as a sequel of variola.

*Frequency of Eye-Disease as a Sequel of Variola.*

Observer.	Number of Small-pox Cases.	Of these the Eyes were affected in
		Per Cent.
Hebra . . . . .	12,000	1
Manz . . . . .	2,000	1.6
Adler—I. Vienna Communspital . . . . .	6	6
II. Vienna Communspital . . . . .	1,182	2.9
Vienna Children's Hospital . . . . .	706	9
Makuna . . . . .	9.7	9.7
Oppert . . . . .	2,755	11

The frequency of ocular complications, it will be seen, varies considerably, and depends to a large extent on the severity of the epidemic. The more severe the disease the greater is the danger to the eyes. Adler observed a series of one hundred cases of small-pox in which the eyes

<sup>1</sup> Wiener Med. Presse, 1877, s. 43.

<sup>2</sup> Loc. cit., s. 11.

<sup>3</sup> Loc. cit. s. 86.

were affected; blindness ensued in only the more severe cases, and not one of those which recovered lost his sight.

The eye-affections of variola are of various kinds, but most of the grave cases are affections of the cornea which supervene during the stage of desiccation or of convalescence. Landesberg<sup>1</sup> observed two hundred and seventy cases of variolous eye-disease, and they were distributed as follows:

	Cases.	Per Cent.
Disease of the conjunctiva . . . . .	156	57.78
Disease of the lacrymal apparatus . . . . .	15	5.55
Disease of the lids . . . . .	3	1.11
Periostitis and caries of the upper orbital wall . . . . .	1	0.37
Disease of the cornea . . . . .	81	30.00
Disease of the iris . . . . .	8	2.96
Disease of the uveal tract . . . . .	4	1.48
Glaucoma . . . . .	2	0.74

from which it is seen that conjunctival and then corneal affections are the most frequent ocular complications of small-pox.

Adler had among one hundred and sixty-five variolous ophthalmias forty-two per cent. of corneal affection. Landesberg had eighty-one cases, or thirty per cent., of corneal affection, and of these the eye was lost in twelve cases. Of Manz's thirty-two cases, four went on to phthisis eorneæ, two to total staphyloma eorneæ, and eleven to the formation of leucoma. From these figures it is evident that variolous keratitis is a very grave affection and often causes loss of sight.

Before the introduction of vaccination, small-pox was a very common and wide-spread disease, and it was responsible for a very considerable proportion of cases of blindness; but the general practice of vaccination has changed this by diminishing the frequency of small-pox and also the virulence of the disease. According to Caron du Villars,<sup>2</sup> before the discovery of vaccination, thirty-five per cent. of all blind persons in France became so from small-pox, but since the introduction of vaccination the percentage has fallen to eight. In Prussia, according to Steffan, before the introduction of compulsory vaccination, thirty-five per cent. of the blind became so from small-pox, and after its introduction but two per cent. of the blind lost their sight by variola. Dumont<sup>3</sup> found that of the one hundred and twenty-two cases of blindness from small-pox which came to the Hospice des Quinze-Vingts, but a single one had been vaccinated, and he had not been vaccinated successfully. Hence we see that vaccination has most markedly diminished the liability to blindness as a sequel of variola, and that these statistics furnish another potent argument in favor of compulsory vaccination.

*Typhoid fever* caused twenty-four cases of double-sided blindness, or

<sup>1</sup> Beitrag zur variolösen Ophthalmie, Elberfeld, 1874.

<sup>2</sup> Quoted by Dumont, Recherches statistiques sur les Causes et les Effets de la Cécité, Paris, 1856, p. 43.

<sup>3</sup> Ibid., p. 45.

0.949 per cent. of Magnus's collected cases, and 5.18 per cent. of his cases caused by systemic disease. Three of these cases were due to disease of the cornea (total leucoma), six to irido-choroiditis, and fifteen to atrophy of the optic nerve. As a consequence of acute fever there occurs sometimes transient, sometimes permanent blindness from affection of the optic nerve and its central termination. In cases of permanent blindness ophthalmoscopic examination reveals generally neuritis, which terminates in atrophy of the optic nerve. Sometimes, however, no pathological condition can be discovered, and atrophy comes on later. Much more frequently such instances of blindness accompany meningitis and epidemic cerebro-spinal meningitis.

*Relapsing fever*, although it does not appear in Magnus's table, is especially noteworthy. Knipping,<sup>1</sup> in an epidemic at Dantzie, observed eye-complications in 3.8 per cent. of the cases, Laehmann in 11 per cent., Luehhau in 3.3 per cent., and Trompeter in 6 per cent. Their frequency and severity vary in different epidemics, but the more severe the disease the more frequent and severe are the eye-complications. They generally involve the anterior part of the uveal tract,—namely, the iris and ciliary body. The disease, according to Fuchs, runs a tedious course, and traces of it with diminution of the power of vision remain. Complete blindness has been observed, but is rare. In seven hundred and thirty cases complicated with irido-choroiditis, Logetsechnikoff saw blindness occur in but three.

*Measles*.—The eye-inflammations accompanying this disease, although severe in many cases, are seldom dangerous to vision: hence we find that, although measles is one of the commonest of the infective diseases, it caused only 2.8 per cent. of the cases of blindness from known causes in the United States in 1890, but 0.633 per cent. of blindness in Magnus's general table, and 3.46 per cent. of his cases from systemic disease. Of the sixteen cases tabulated, fifteen were due to destruction of the cornea and one to atrophy of the optic nerve.

*Scarlet fever*, although a very prevalent disease, is but seldom accompanied by serious eye-troubles, but when they do occur they are generally of a formidable character. It caused but 1.75 per cent. of the cases tabulated in the last United States census report, 0.514 per cent. of the general table of Magnus, and 2.81 per cent. of his cases from systemic disease. Seven of the thirteen cases tabulated by Magnus lost their sight through blennorrhœa, three of the remaining cases presented evidences of an old irido-choroiditis, and two had atrophy of the optic nerve as the cause of their scarlet-fever blindness.

*Cerebro-spinal meningitis* may cause severe inflammation of the uveal tract. Both the epidemic and sporadic forms may be complicated with irido-choroiditis. Usually it is of a purulent character and leads to shrivelling of the eye, with complete blindness. It is chiefly met with in children under five years of age.

---

<sup>1</sup> Quoted by Fuchs, loc. cit., s. 90.

*Erysipelas.*—Neuritis terminating in blindness sometimes occurs in erysipelas of the head. Magnus notes two such cases in his collection of 2528 cases of blindness. The neuritis was produced either by inflammation of the orbital cellular tissue or by complication of erysipelas with meningitis.

In all these cases the prophylactic treatment must be directed to the fundamental disease, not to the secondary affection of the optic nerve.

*Pregnancy, Childbed, and Lactation.*—Under this head are included cases of blindness which have been observed as consequences of pregnancy, the puerperal state, or lactation, and in which the pregnancy or lying-in apparently ran a normal course. Of this class Magnus's general table shows eleven cases, or 0.431 per cent. In three of these cases blindness came on during pregnancy, in seven during childbed, and in one during lactation. Magnus gives the following table of the form of blindness in these cases, and includes two cases of albuminuric retinitis which were tabulated under diseases of the uropoietic system, thus making thirteen in all.

*Blindness following Pregnancy.*

Form of Blindness.	Pregnancy.	Childbed.	Lactation.
Optic atrophy . . . . .	1	4	1
Irido-choroiditis . . . . .	1	3	..
Albuminuric retinitis . . . . .	2	..	..
Detachment of the retina . . . . .	1	..	..

In puerperal fever, as well as in certain general infections, the eyes may be lost by suppuration starting from the irido-choroidal apparatus,—that is, by metastatic choroiditis. Purulent choroiditis arising from metastasis from some deposit of pus, Fuchs believes to be much more common than is generally supposed, and he has often observed it in the large lying-in hospitals of Vienna. As patients affected with it are very seriously ill, and, as a rule, die, the eye-affection attracts but little attention, and the oculist, especially, seldom hears of it. The affected eye is irretrievably lost, and not uncommonly both eyes are simultaneously or successively attacked. Notwithstanding this, the number of those rendered blind from this cause is small, for very few of those who have the serious general disease recover from it.

*Syphilis* is the cause of many eye-affections, and there is scarcely any part of the eye that may not be invaded by it; but it seldom produces complete blindness. Colin found among twenty thousand patients but 1.15 per cent. of syphilitic eye-disease, and Coccius but 1.16 per cent. in his clinic. Magnus found that but 0.47 per cent. of his blind cases owed their blindness to this disease. Of the twelve cases tabulated by the latter observer, two owed their blindness to optic atrophy and ten to iritis or choroiditis. Many other cases which had a syphilitic origin have been manifestly tabulated under other headings, and they include affections of the choroid, retina, and optic nerve.

*Scrofula*.—According to the Russian<sup>1</sup> census figures, scrofula was the cause of blindness in 1.75 per cent. of the cases, and in the last United States census scrofula and other blood-diseases are credited with 5.75 per cent. In Magnus's general table it shows only a percentage of 0.039. It is in fact responsible for a much larger percentage, but many of the cases due to scrofula have been tabulated under corneal affections. Birch-Hirschfeld<sup>2</sup> places the number of blind from scrofulous ophthalmia in the Saxony blind asylums as six per cent. of the total number under twenty years of age. Scrofula, however, appears to be responsible for many cases of blindness of which it is not the direct cause; included in this category are many of the cases of blindness from mechanical irritation of the cornea occurring in subjects who have suffered from scrofulous disease of the cornea.

Among other *chronic general diseases* which cause injury to the sight and in rare cases blindness are leukæmia, pernicious anæmia, scurvy, albuminuria, diabetes, hysteria, rachitis, chronic rheumatism, and gout. In none of these cases is special prophylaxis possible.

*Chronic poisoning* was responsible for but a single case, or 0.039 per cent., in Magnus's general table.

Tobacco and alcohol cause affections of the optic nerve which very rarely lead to total blindness, but all the more frequently lead to impairment of vision, ending, perhaps, in atrophy of the papilla. The noxious agent in tobacco is nicotine, which is found in larger proportions in the cheaper qualities of tobacco, which are, therefore, the more injurious. According to Fuchs, nicotine heated to 250° F. is volatilized and decomposed, but if watery vapor is present, volatilization takes place without decomposition. When dry tobacco is smoked the greater part of the nicotine is decomposed by the heat. The moister the tobacco—and the cheaper kinds are generally damp—the greater the quantity of nicotine that passes into the smoke with the watery vapor. Chewing tobacco is also injurious, as the tobacco used for this purpose is generally rich in nicotine.

Tobacco amblyopia constitutes from 0.6 per cent. (Hirschberg) to one per cent. (Foerster) of all eye-patients, and by far the larger number of cases are met with in persons over forty years of age.

Bisulphide of carbon seems to produce blindness in much the same way as tobacco.

The abuse of alcohol sometimes causes amblyopia the symptoms and course of which greatly resemble those of tobacco amblyopia. The one case given in Magnus's table was due to alcoholism. In most cases tobacco and alcohol act together. Fusel oil is said to be the noxious agent in producing alcoholic amblyopia.

Chronic lead or mercurial poisoning sometimes causes optic neuritis,

<sup>1</sup> Schaefer, loc. cit., s. 11.

<sup>2</sup> Art. Scrofula, Ziemssen's Hand-Book of Special Pathology and Therapeutics, New York, 1877, vol. xvi. p. 797.



from which atrophy of the optic nerve may result, and sometimes an albuminuric retinitis secondary to the kidney-trouble.

Snake-bite is mentioned, on the authority of Leber,<sup>1</sup> as responsible for one case of double-sided blindness.

#### INFLUENCE OF OCCUPATION ON EYE-DISEASE.

The affections of the eye in their relation to occupation may be divided into the traumatic and the non-traumatic. The chief of the latter is myopia, which is the eye-defect of study, but certain trades which require minute and long-continued looking at objects close to the eye also tend to render the eyes myopic. Cohn examined the eyes of a large number of artisans in Breslau, and found among watchmakers nine and seven-tenths per cent. of myopes; gold- and silver-workers, twelve per cent.; lithographers, forty-five per cent.; compositors, fifty-one per cent.

Emmert<sup>2</sup> found in four Swiss watchmakers' schools the proportion of myopes was even higher,—namely, fourteen per cent. Other trades, such as engravers, tailors, seamstresses, shoemakers, needle-makers, etc., are also conducive to myopia.

The statistics of myopia show very convincingly the danger which the eyes incur in continuous use for near work. Seidelmann holds that those occupations which thus throw the largest amount of strain upon the eye give a large percentage of cases of those forms of blindness which are developed from myopia,—viz., detachment of the retina and central retinitis; but Magnus thinks that we have not yet obtained sufficient statistical data to enable us to reach a definite conclusion upon this point.

Myopia in the majority of cases remains stationary at a low degree; but, on the other hand, in a certain minority the short sight attains such a height that it seriously threatens to destroy the sight in the course of time. The cases of absolute blindness as a consequence of short sight are rare in comparison with the large number of myopes. According to Magnus, choroiditis e myopia furnishes 0.94 per cent. of the blind. To these may be added a portion of the cases of detachment of the retina, which altogether constitute 5.68 per cent. of blind persons. On the other hand, much more numerous is the number of myopes who, as they grow older, have their sight become so much impaired as to render them incapable of self-support. Cohn, in his statistics, includes all eyes which are useless for work. He gives the percentage of cases of detachment of the retina as a consequence of myopia as 4.6 per cent., of retinitis centralis e myopia as 6.3 per cent.; so that myopia is the cause of 10 per cent. of all cases of blindness of one eye.

The prevention of the disturbances of vision caused by short-sightedness and followed by amaurosis is identical with the prophylaxis of my-

<sup>1</sup> Handbuch d. ges. Augenh., v. ii., s. 890.

<sup>2</sup> Nagel's Jahresbericht, 1877, s. 368.

opia. The serious dangers to the eyes which may arise during the period of school life, and the means for their prevention, are well known, and this subject is given full consideration in another part of this work. The exercise of the proper hygienic precautions there described, both at home and in school, and proper physical care of the body, are the principal factors in the prophylaxis of myopia.

#### THE PREVENTION OF BLINDNESS.

In studying the prevention of blindness, Cohn<sup>1</sup> arranges his statistics into three series. In the *first* he includes all the cases of atrophy, inflammation of the retina and optic nerve, tumors, typhoid, diphtheria, and congenital blindness,—that is to say, the chief causes of blindness which are *absolutely incurable*. In the *second* are collected the cases of detachment of the retina, central inflammation of the retina in myopia, and all cases of inflammation of the iris and cornea in which a cure is possible under proper treatment; furthermore, all unsuccessful operations, half of all injuries, and all blindness from unknown causes,—that is, blindness which *might possibly have been prevented*. And in the *third* series are embraced the other half of injuries, all cases of blennorrhœa, all cases of acute glaucoma, all cases of syphilis, trachoma, and variolous inflammation,—that is, cases which could have been prevented by proper prophylaxis, or in their beginning could have been cured by proper treatment. From this study Cohn reaches the lamentable conclusion that among 1000 blind there were only 225 unavoidable cases, 449 that were possibly avoidable, and 326 cases that were absolutely avoidable; or, in other words, that one-third of the cases of blindness are absolutely preventable; and, as all cases of eye-injury do not lead to blindness, it may be safely assumed that a still larger proportion of cases of eye-disease are curable.

Steffan and Rössler have arrived at similar conclusions, and they reckon the cases of blindness from curable causes at 40 per cent. of all cases of blindness. Dürr, in 1885, found among the pupils in the blind asylum at Hanover that in 46 per cent. the blindness was unavoidable, in 14 per cent. it was questionable as to its avoidableness, and in 40 per cent. it was certainly avoidable. Hasket Derby<sup>2</sup> found that in the 183 inmates of the Perkins Institution for the Blind in South Boston personally examined by him there were fifty cases, or 27 per cent., of preventable blindness. Herrenheiser, in 1888, out of 3735 cases of blindness in Bohemia, found 23 per cent. unavoidable, 45 per cent. possibly avoidable, and 32 per cent. certainly avoidable. Trousseau, in examining 627 cases of blindness in the Hospice National des Quinze-Vingts, found that 31.26 per cent. were absolutely unavoidable, 39.23 per cent. were possibly avoidable, and 29.51 per cent. were certainly avoidable.

<sup>1</sup> Lehrbuch der Augenheilkunde, s. 760.

<sup>2</sup> Boston Medical and Surgical Journal, 1889, cxxi. p. 402.

*Statistics of Avoidable Blindness.*

Observer.	Percentage of absolutely unavoidable.	Possibly avoidable.	Certainly avoidable.
Hirschberg . . . . .	31	29	40
Breiner-Völkers . . . . .	39.7	26.3	34
Seidelmann and Cohn . . . . .	19.4	37.6	43
Landesberg . . . . .	17.9	59.1	23
Stolte-Schirmer . . . . .	14.9	59.8	25.3
Dürr . . . . .	46	14	40
Herrenheiser . . . . .	23	45	32
Trousseau . . . . .	31.26	39.23	29.51
Average . . . . .	27.89	38.75	33.35

If it be admitted that blindness could have been avoided in one-third of the cases in which avoidability was regarded as uncertain,—and this is certainly a conservative estimate,—then blindness could have been prevented in 46.27 per cent. of the whole number of cases tabulated by the above observers.

In corroboration of his views on avoidable blindness, Cohn cites the statistics of 70,174 cases of eye-disease from his Wiesbaden clinic in 1887. Of preventable causes of blindness, he found :

	Cases.	Per Cent.
Blennorrhœa . . . . .	735	
Scrofula . . . . .	12,910	
Trachoma . . . . .	3,845	
Variola . . . . .	7	
Strabismus and asthenopia from hypermetropia . . . . .	1,163	
Myopia . . . . .	12,452	
Onanism . . . . .	208	
Syphilis . . . . .	357	
Alcohol and tobacco indulgence . . . . .	188	
Dazzling . . . . .	30	
Injuries . . . . .	3,703	
	<u>35,598</u>	50.73

From these he deducts one-half of the cases of myopia and of injuries as not curable,—that is, 8077,—leaving 27,521, or 39.22 per cent., as avoidable.

THE DIMINUTION OF BLINDNESS.

A large proportion of cases of blindness are, as we have seen, unquestionably preventable, and with our better knowledge of the pathology and treatment of eye-affections we have reason to believe that the proportion of cases of blindness is steadily diminishing, and this belief is confirmed by the census statistics of countries for which we have records for a series of decades. The figures of the United States census, prior to 1880, are stated to be worthless so far as calculations of ratios of blind to population are concerned.

In 1880 there were 976 blind to the 1,000,000 of population.

In 1890 there were 808 blind to the 1,000,000 of population.

In England and Wales there has been a steady proportionate decrease in the ratio of the blind to the general population with each successive decade. Thus,

In 1851 there were 1021 blind to the 1,000,000 of population.

In 1861 there were 964 blind to the 1,000,000 of population.

In 1871 there were 951 blind to the 1,000,000 of population.

In 1881 there were 879 blind to the 1,000,000 of population.

In 1891 there were 809 blind to the 1,000,000 of population.

The extent of the decrease in England and Wales may be stated in the following form. Had blindness been as common an affection in those countries in 1891 as it was in 1851 there would have been 29,609 blind inhabitants instead of 23,467, or 26.17 per cent. more.

In Scotland, while the decrease has not been so regular, it has been steady. Thus,

In 1861 there were 920 blind to the 1,000,000 of population.

In 1871 there were 809 blind to the 1,000,000 of population.

In 1881 there were 845 blind to the 1,000,000 of population.

In 1891 there were 698 blind to the 1,000,000 of population.

The same is also true of Ireland, where

In 1861 there were 1289 blind to the 1,000,000 of population.

In 1871 there were 1174 blind to the 1,000,000 of population.

In 1881 there were 1180 blind to the 1,000,000 of population.

In 1891 there were 1135 blind to the 1,000,000 of population.

This diminution is also shown in the census returns of other countries. Thus, in Prussia, in 1871, there were 932 blind to the 1,000,000 of population ; in 1880, 831. In Saxony, in 1871, 790 ; in 1880, 710. In Holland, in 1864, 600 ; in 1889, 440. In Austria, in 1880, 940 ; in 1890, 810. In Italy, in 1861, 952 ; in 1871, 1049 ; in 1881, 761.

There has been, unquestionably, a gratifying diminution in the number of the blind, as well as a shortening of the period of blindness, due to the progressive improvement in our knowledge of the proper treatment of the affections of the eyes, and particularly of the ophthalmia of the new-born infant, to the diminished prevalence of small-pox on account of the general practice of vaccination, to which a considerable number of cases of blindness was formerly owing, and to the greater care taken against the occurrence of injuries to the eyes in factories and workshops. The decrease from the latter cause, however, has not been uniform in all occupations, and there has been probably an increase in the number of blind among workers in certain trades, such as locomotive engineers, iron-puddlers, and glass-blowers.

In concluding this article the author takes pleasure in expressing his deep obligation to the valuable and exhaustive work of Magnus, to which he has constantly referred in its preparation.

# ANTISEPSIS.

BY JOSEPH A. ANDREWS, M.D.,

Ophthalmic Surgeon to the Charity Hospital, New York City, New York, U.S.A.

---

THE great practical revolution brought about by antiseptics in the management of wound infection should always furnish an incentive to the student occupied in scientific investigation which may, for our time, appear to be of mere theoretical interest; for we know that the Listerian idea was based on purely scientific facts deduced from the researches of Pasteur; and, although the details of Lister's treatment have been replaced by measures which maturer experience has shown to be better suited to the purpose, it must remain the immortal merit of Lister to have inaugurated the method of wound treatment which to-day furnishes the surgeon with such potent means for saving human life.

The agents of infection and the individual exposed to infection constitute such varying and often complicated factors in the study of wound infection that it were vain to attempt here an exhaustive treatment of the questions involved in the consideration of the subject; moreover, our knowledge does not justify such an attempt. It will, therefore, be our aim to present briefly the facts furnished by our present knowledge concerning some of the more important questions, and to indicate the practical lesson deduced from experience in the prevention and treatment of wound infection.

There can now be no doubt as to the importance and necessity of antiseptics in eye surgery. Sir Joseph Lister long ago furnished proof that purulent inflammation following an injury is caused by inoculation with micro-organisms in the wound. We have since then learned that the capability of micro-organisms to give rise to inflammation and disease in general depends upon the production of certain poisonous substances known as toxins. It has also been demonstrated by numerous investigators that dead bacteria of many different species give rise to suppuration when injected subcutaneously. We have further learned the erroneousness of the belief that suppuration is always dependent on the presence and action of micro-organisms, for it is now well established by experiments that certain chemical substances—*i.e.*, quicksilver, oil of turpentine, etc.—introduced beneath the skin give rise to the formation of pus, quite independently of micro-organisms, but that this pus has not the same power of extension as that produced by the action of micro-organisms, because the latter, being living, active organisms, multiply and spread. But these investigations have refuted the belief, which once prevailed, that all foreign

substances introduced into the tissues of the body must give rise to inflammation; for it has been shown that chemically inert substances, sterilized by heat and introduced into the body, do not give rise to inflammation in consequence of chemical action. If such inert substances excite purulent inflammation, the latter is due not to the action of the foreign body itself, but to micro-organisms introduced with the foreign body or which have entered the wound subsequently.

Leber has shown, in a simple experiment, that if a suitable piece of glass or gold be introduced through a small wound, made under due antiseptic precautions, into a rabbit's eye, no inflammation is excited, and that the foreign body may be seen for months or years afterwards, free and in an unclouded fluid. Degeneration and proliferation may be excited in the tissues of the eye by such inert foreign bodies, but they are unlike those following an infected wound. Experiments, therefore, prove that not only the products of micro-organisms, but also pure chemical substances, are capable of exciting purulent inflammation.

It has been demonstrated that a number of species of bacteria, either living or in sterilized cultures; give rise to suppuration; but it has also been shown that the most important species of bacteria concerned in the formation of pus (acute abscesses, furuncles, etc.) are, in the order of their occurrence, *staphylococcus pyogenes aureus* and *staphylococcus pyogenes albus*, *staphylococcus pyogenes citreus*, *staphylococcus cereus flavus*, *micrococcus tetragenus*, *micrococcus pneumoniae crouposæ*. We may find two or more species in the same abscess. If a decoction of any one of these species be prepared in distilled water and all life be destroyed by heat, it still produces an active purulent inflammation when injected under the skin or into the anterior chamber of the eye. Hence it is assumed that the action of micro-organisms is dependent on chemical energy. Thus, abscesses containing sterile pus have been produced with subcutaneous injections of agar cultures of the anthrax bacillus sterilized by heat (Wyssokowitsch<sup>1</sup>). The same thing has been done with sterilized cultures of Friedländer's bacillus pneumococcus (Buchner<sup>2</sup>). Similar results have been produced with a number of different species. Inasmuch as the clear fluid obtained after filtration of pure cultures was without effect, while the dead bacteria which did not pass through the filter produced a sterile purulent infiltration when injected into the subcutaneous tissues, Buchner concluded that the pus formation is not due to a chemical substance produced by the bacteria, but that this property belongs to the albuminous contents of the bacterial cells.

It has been found that, in spite of rigid antiseptic precautions, micro-organisms are found attached to sutures removed from wounds made by the surgeon, and that the so-called skin-abscess in such cases is caused by the

---

<sup>1</sup> Ueber den Ursprung der Eiterung, *Vrachs*, 1887, S. 667.

<sup>2</sup> *Centralb. f. Bakteriologie*, 1890, Bd. viii. S. 321.

*staphylococcus epidermidis albus* (Welch<sup>1</sup>). This bacterium has but slight virulence.

We have learned, especially from the investigations of Metchnikoff, that in certain infectious diseases due to bacteria the micro-organisms at the point of inoculation or in the general circulation of the blood are picked up largely by the leucocytes, and, it is believed, in many instances destroyed in their interior. This, at least, is the theory of phagocytosis. The lymphocyte, however, has never been observed to take up bacteria. We now have experimental proof that blood-serum, independently of cellular elements contained in it, has germicidal power for certain pathogenic bacteria; but in the experiments that have been made more recently to determine whether pathogenic bacteria are destroyed by the leucocytes which have picked them up, different investigators have been led to different results. We cannot, therefore, consider the question as definitively settled. The germicidal power of blood as well as of serum is destroyed by exposure for an hour to a temperature of 55° C., but freezing does not destroy this power of blood-serum.

For practical purposes we may assume that purulent inflammation as met with by the surgeon always depends on the presence of certain forms of bacteria; *i.e.*, the presence of certain varieties of bacteria is an essential condition of wound infection.

#### WAYS BY WHICH PATHOGENIC BACTERIA MAY REACH A WOUND.

A variety of micro-organisms are, under certain conditions, present in the air. Cocci, bacilli, torula cerevisiæ, and mould fungi are common inhabitants of the air, and are generally found together; but all these are present in fluctuating numbers, the fluctuation depending on the same conditions. The air of large cities is richer in germs than that of the country; in wet weather they are, as a general thing, less numerous than in dry weather; and they are less numerous in calm than in stirring air.

But it is not, as was formerly supposed, the atmosphere that hatches out and harbors the germs in the first place and gives rise to infection secondarily: it is rather the opposite state of things that obtains. Microbes thrive in organic material, and leave this to enter the air only under certain conditions. All the conditions which micro-organisms require in order to multiply—*i.e.*, warmth, moisture, and nutrient materials—are not found in the air. The atmosphere, therefore, is an unfavorable retreat for micro-organisms. The breath does not, as was shown by Tyndall, contain micro-organisms. Bacteria do not escape into the air from the surface of fluids rich in micro-organisms, but the deposit of such fluids resulting from change of level, etc., may be rich in bacteria, and when dried furnishes material which is readily carried into the air when the latter is disturbed by draughts, etc., and in this way becomes a source of danger. It has been shown that foul-smelling air often contains fewer germs than that which passes for pure;

<sup>1</sup> Trans. Cong. Amer. Phys. and Surgs., 1891, vol. ii. p. 21.

thus, the stinking air of privies, etc., is often bacteriologically purer than the air of the streets and dwellings (Schimmelbusch). Tyndall<sup>1</sup> has shown that in a closed vessel in which the air is perfectly still all suspended particles are soon deposited on the bottom of the vessel. This is but experimental proof of the well-known fact that the dust of the air is carried by the wind from exposed surfaces, and is again deposited when the air is at rest. For example, Neumann,<sup>2</sup> whose researches were made in a hospital, found the greatest number of bacteria in the air in the morning after the patients had left their beds and the wards had been swept. Thus, the dust of a room in which a patient with pulmonary consumption expectorates occasionally upon the floor contains tubercle-bacilli. The staphylococcus pyogenes aureus, which outranks in point of frequency, and, therefore, importance, all other bacteria which produce suppuration, has frequently been found in the dust floating in the air of surgical wards where there are suppurating wounds. The streptococcus of erysipelas has been found in the air of a ward containing erysipelas. Therefore, while the dust of the atmosphere may be harmless, it may, from various causes, contain bacteria which are capable of producing disease.

It has been shown that a number of species of micro-organisms may give rise to suppuration in a wound, but, as has been pointed out by Ogston,<sup>3</sup> Rosenbach,<sup>4</sup> Passet,<sup>5</sup> and others, that a few species are generally concerned in the formation of pus, and that of these the two most important, because they are most frequently found and have the greatest pathogenic power, are staphylococcus pyogenes aureus and streptococcus pyogenes; next, staphylococcus pyogenes albus, and occasionally staphylococcus pyogenes citreus, staphylococcus cereus flavus, staphylococcus cereus albus; all of which, together with other pyogenic and pathogenic bacteria, have been shown to be occasionally present in the air. Therefore we cannot afford to disregard the air as a possible and probable source of infection; and if Von Volkmann actually made the statement which has been attributed to him,—*i.e.*, “Auch auf einem Abtritte würde ich dreist operiren wenn die Hände rein wären,”—it should be regarded only as emphasizing the actual truth, in which there is now general agreement of opinion, that the greatest danger to a wound is contact with infected hands, instruments, and other objects, and that surgeon will act most strictly in conformity with the best teaching, based upon bacteriological facts, who gives due regard to the influence of currents of air and commotion in the operating-room in stirring up dust, and will have the room so constructed that the walls and floor and all that is in the room can be readily cleansed.

<sup>1</sup> On the Floating Matter of the Air in Relation to Putrefaction and Infection.

<sup>2</sup> Vierteljahrsschrift f. gerichtl. Med., etc., 1886, Bd. xlv. S. 310.

<sup>3</sup> Report upon Micro-Organisms in Surgical Diseases, Brit. Med. Jour., 1881, i. 369.

<sup>4</sup> Mikroorganismen bei den Wundinfektionskrankheiten des Menschen, Wiesbaden, 1884.

<sup>5</sup> Ueber Mikroorganismen der eitrigen Zellgewebsentzündung des Menschen, Fortschritte der Med., 1885, No. 2, S. 68.



**Auto-Infection.**—It is known that pyogenic cocci are often present in the alimentary canal. In lesions of the intestinal mucous membrane, such as ulceration, diphtheritis, hemorrhage, and traumatism, there is frequent invasion by pyogenic cocci. Therefore we may explain the invasion by these cocci in such diseases as diphtheria, scarlet fever, typhoid fever, etc., by assuming that these lesions open a way for the bacteria into the circulation, and that the toxic substances in the body belonging to the primary disease in some way weaken the power of the tissues to resist the action of bacteria. Rinne<sup>1</sup> injected sterilized putrid fluids, together with staphylococci, into the peritoneal cavities of dogs. In these cases all open wounds, which otherwise healed kindly, suppurated; the subcutaneous wounds, however, were unaffected; but the bacteria found in the suppurating open wounds were derived from the air. However, Rinne's conclusion, that such wounds may not become infected from pyogenic cocci in the circulation, has been disproved by the experiments of De Wildt<sup>2</sup> and others, who have demonstrated that infection may take place in this way.

**Infection from Skin of Patient and Operator.**—The skin, like the mucous lining of the mouth, may have all kinds of bacteria on its surface; but the prevailing organism in the skin appears to be the staphylococcus epidermidis albus of Welch,<sup>3</sup> and this coccus is found in parts of the skin too deep to be reached by any means of cutaneous disinfection which may be safely employed. Welch regards this coccus as a nearly constant inhabitant of the epidermis. It possesses feeble pyogenic power. The presence of this coccus in the deeper layers of the epidermis explains the occurrence of stitch abscesses when every possible antiseptic precaution has been taken. Bossowski<sup>4</sup> found from bacteriological examination that of fifty fresh wounds treated antiseptically ten were with negative and forty with positive result. He found the staphylococcus albus twenty-six times, the staphylococcus aureus nine times, the staphylococcus pyogenes twice, and other organisms (non-pathogenic) eight times. The healthy mucous surfaces of the eye and its appendages are similarly visited by micro-organisms.

#### MICRO-ORGANISMS OF CONJUNCTIVAL SAC OF HEALTHY EYE.

Fick,<sup>5</sup> Michel,<sup>6</sup> Gombert,<sup>7</sup> Van Genderen Stort,<sup>8</sup> Leber,<sup>9</sup> and others have shown that, as a rule, few bacteria are present in the healthy conjunctival sac; on the other hand, it has been proved that the apparently healthy

<sup>1</sup> Ueber den Eiterungsprocess u. seine Metastasen, Berlin, 1889, S. 61.

<sup>2</sup> Abstract in Centralblatt f. path. Anat., 1890, Bd. i. S. 9.      <sup>3</sup> Op. cit., S. 21.

<sup>4</sup> Wiener Med. Wochenschr., 1887, No. 9, S. 258.

<sup>5</sup> Ueber Mikroorganismen im Conjunctivalsack, Wiesbaden, 1887.

<sup>6</sup> Lehrbuch der Augenheilk., 1890, S. 784.

<sup>7</sup> Recherches expérimentales sur les Microbes des Conjonctives à l'état normal. Published by Masson, Paris, 1889.

<sup>8</sup> Ueber die mechanische Bedeutung der natürlichen Irrigation des Auges, Arch. f. Hygiene, 1891, Bd. xiii. S. 395.

<sup>9</sup> Ueber die Entstehung der Entzündung, Leipzig, 1890, S. 185.

conjunctival sac may contain micro-organisms, even those that are pathogenic. Again, Fick, Weeks,<sup>1</sup> Gayet,<sup>2</sup> Leber,<sup>3</sup> and Bernheim<sup>4</sup> have introduced pure cultures of staphylococcus pyogenes aureus into the conjunctival sac of man, and no reaction has followed.

In order to study the harmless, non-pathogenic micro-organisms in the conjunctival sac, Fick examined the secretion from eighty-five eyes of fifty-seven beneficiaries of the Julius Hospital at Würzburg, who either had normal eyes or only a chronic catarrhal affection. In only six of the eighty-five cases were no micro-organisms found. In only one instance were both eyes free from bacteria. Bacilli were most frequently met with in the secretion of healthy conjunctivæ. Of the eighty-five conjunctivæ examined, forty-nine were normal, in thirty-nine bacilli were found, and in nine bacilli and cocci; in thirty-six, which were pathological, bacilli were found in all, and in twenty bacilli and cocci. Cocci alone were not met with in any case. To meet the objection that the almost constant presence of bacilli might be a peculiarity of the Julius Hospital, Fick also examined the secretion from the healthy conjunctivæ of twenty-six persons. In eighteen, bacteria were found; in the remaining thirty-four, however, no micro-organisms were found. In fifteen of these cases he found bacilli, in seven bacilli and diplococci, and in two tetrads. Leber found the conjunctival sac frequently free from bacteria. Franke<sup>5</sup> examined carefully sixty-one eyes, of which fifty-six showed a normal or nearly normal mucous membrane. In these sixty-one cases he found the staphylococcus pyogenes flavus and albus ten times. He found the micro-organisms described by Gombert, all of which have pathogenic properties, as shown by inoculation of rabbits' corneæ, in which they produced small grayish-white infiltrations. Franke found two varieties of bacilli which resembled the xerosis bacillus. Neither of these bacilli had pathogenic properties. Franke's results agree essentially with those of Bernheim and Hildebrandt.<sup>6</sup> Franke showed that seventy-two per cent. of normal-appearing conjunctivæ contain bacteria. Fraenkel<sup>7</sup> declares that in genuine diphtheria virulent and attenuated Löffler's bacilli occur, and that the latter are even found on the healthy conjunctiva, mouth, and pharynx.

#### ANTISEPTICS AND DISINFECTANTS.

The term *antiseptic* is here used to designate the agents which restrain the development of micro-organisms without destroying their vital-

<sup>1</sup> Arch. of Ophthal., vol. xvi. p. 376.

<sup>3</sup> Arch. d'Ophthalmologie, 1887, t. vii. p. 385.

<sup>3</sup> Die Bedeutung der Bakteriologie, etc., Seventh Internat. Ophth. Congress, Heidelberg, 1888, S. 346.

<sup>4</sup> Inaugural Dissertation, Zürich, 1893, p. 9.

<sup>5</sup> Untersuchungen über die Desinfection des Bindehautsackes, nebst Bemerkungen zur Bakteriologie desselben, A. von Graefe's Arch. f. Ophth., Bd. xxxix. Abth. iii.

<sup>6</sup> Experimentelle Untersuchungen über Antiseptis bei der Staaroperation, Inaugural Dissertation, Zürich, 1893.

<sup>7</sup> Berliner Klin. Wochenschr., 1893, No. 11, S. 254.

ity, their complete destruction being effected by means of *disinfectants* or germicides.

When we employ chemicals for the disinfection of a wound, we must remember that it is not possible to kill all the bacteria in the wound by such means, because many of these resist the action of the chemical agents; then some of these that are not killed are removed mechanically. We know the agents which excite infection in a wound, but we are not so well informed as regards the origin and course of the infective process. The pyogenic bacteria do not by any means always excite suppuration in a wound. There are factors on the part of the microbe and the human body necessary in order that infection may take place, but our knowledge respecting these factors is defective. The chief thing with which we have to concern ourselves in connection with disinfection is the fact that, in a surgical sense, wound infection is dependent on micro-organisms which have entered the wound. We must, therefore, aim to exclude germs from the wound. We should also remember that living tissues do not admit of artificial disinfection without at the same time jeopardizing the living process in cells. As has been said, the conjunctivæ of the eyeball and lids may in a healthy state contain germs which are capable of exciting infection. We must, therefore, determine the best means of combating such germs.

**Chemical Disinfectants.**—In estimating the value of a chemical disinfectant we must consider the kind of bacteria to be acted upon by the chemical agent and the time necessary to arrest their growth or destroy them. The spore-bearing bacteria have a greater resisting power to chemical agents as well as heat than the vegetative forms. It is, therefore, of practical importance in connection with disinfection to know which pathogenic bacteria form spores and which do not.

*Spore-bearing bacteria which excite wound infection :*

Bacillus of anthrax,

Bacillus of tetanus,

Bacillus of tuberculosis.

*Pathogenic bacteria which do not form spores :*

The cocci of pus (*staphylococcus pyogenes aureus, albus, and citreus, streptococcus pyogenes*),

*Staphylococcus* of erysipelas,

Bacillus of diphtheria (Löffler),

Bacillus of glanders.

The anthrax bacillus is the most resistant of the spore-bearing germs, and the pyogenic staphylococcus has also great powers of resistance.

The method of determining the value of a chemical disinfectant is not wholly satisfactory. To test the power of a chemical agent to restrain the growth of a particular micro-organism, a suitable culture-medium, in which the agent to be tested is dissolved in a definite proportion, is inoculated with a pure culture of the bacterium to be tested, the whole being placed in the incubator at the favorable temperature. If no development occurs in the

culture-medium containing the antiseptic nor in the control experiment, we attribute the failure to grow to the agent added to the culture-medium. In this way by further experiment we determine the exact amount required to restrain development under like conditions. To determine the *germicidal* power of a chemical agent, the test most used is that employed by Koch, of suspending silk threads to which are attached the germs to be experimented upon in the germicide. After an exposure for a certain time to the germicide, the threads are transferred to a suitable culture-medium. The loss of vitality is thus tested by culture experiments with the germs which have been acted upon by the germicide chosen, or by inoculation of animals with them.

This mode of investigation is not wholly satisfactory, for we may, even when the thread is washed in distilled water, carry over some of the germicide to the culture-medium or animal body inoculated, and thus diminish the value of the experiment. Geppert has shown that even the smallest trace of the antiseptic which may be carried over with the germs to the culture-medium may materially affect the results of the disinfection, and that the mere washing does not suffice, but that it is necessary to neutralize the antiseptic chemically in order to make the test valid. Geppert used a solution of sulphide of ammonium for this purpose. Koch found that the development of the anthrax spores was restrained by a 1 : 300,000 solution of sublimate. Geppert, on the other hand, declares that, while a solution of sublimate 1 : 1000 restrained the growth of spores (anthrax) in three minutes, if the growth was treated with a solution of sulphide of ammonium before the transfer to the culture-medium, the growth was not restrained after fifteen minutes, and in five instances he obtained cultures after twenty-four hours.

In our estimate of the germicidal action of a chemical agent we must take into account the conditions under which the test is made. Such oxidizing agents, for example, as chloride of lime and permanganate of potassium act not alone upon the bacteria, but upon all organic matter with which they are placed in contact; thus there is a simultaneous destruction of the germicide by the chemical reaction. It is, therefore, important to consider the presence of organic material which may be associated with the bacteria; for if this be in excess the chemical agent may be destroyed. Thus, the germicidal power of bichloride of mercury is reduced by albumin.

It was formerly thought that a two-per-cent. solution of *carbolic acid* surely killed all micro-organisms in a few seconds or minutes. The surgeon washed his hands and instruments with it, and believed that he had thereby made his hands and instruments free from infective material, and could therefore touch his patient's wound without danger; but Koch<sup>1</sup> showed that if the spores of the anthrax bacillus or similar infective germs with equal powers of resistance happened to be on the operator's

---

<sup>1</sup> Mittheilungen aus dem Kaiserl. Gesundheitsamt, 1881, S. 241.

hands or instruments and were not mechanically removed by the washing, the addition of carbolic acid to the wash-water could not have been of the slightest use in protecting the patient against infection. He found that the spores were destroyed by different solutions of carbolic acid in the following order: a one-per-cent. solution, even after fifteen days, exerted no remarkable action; after seven days in a two-per-cent. solution the spores were still active when mice were inoculated with them; a three-per-cent. solution killed only after seven days; a four-per-cent. solution killed on the third day; and a five-per-cent. solution killed with certainty on the second day. We must, in these experiments, also take into account the number of spores to be destroyed. At the temperature most favorable for the growth of the reproductive elements under investigation a greater strength of the antiseptic agent is required than at an unfavorable temperature, lower or higher.

Geppert failed to destroy with certainty *staphylococcus pyogenes* and *baeillus pyocyaneus* with a 1 : 1000 solution of sublimate in from ten to fifteen minutes. Schill<sup>1</sup> and Fischer failed to disinfect fresh tuberculous sputum after exposing it to an equal amount of a 1 : 2000 sublimate solution for twenty-four hours. Yersin,<sup>2</sup> on the other hand, declares that the tubercle-baeillus is killed in one minute by a 1 : 1000 solution of sublimate, in thirty seconds by a five-per-cent. solution of carbolic acid, and in one minute by a one-per-cent. solution of this acid. Yersin's experiments, however, were made with the baeillus in an artificial culture-medium, and not, as in Geppert's, with the baeillus in sputum. The pus-coeci are restrained in their growth by a 1 : 3000 solution of sublimate; but the temperature of the solution must be considered. Thus, Behring<sup>3</sup> found that at 22° C. *staphylococcus aureus* in bouillon is not always killed after twenty-five minutes. Abbott<sup>4</sup> says that a 1 : 1000 sublimate solution does not always destroy *staphylococcus aureus* in fifteen minutes.

But laboratory experiments with pure cultures of bacteria do not always help us in practice. The conditions under which bacteria exist in a wound are different from those which obtain in a culture-medium in a test-tube. Disinfection is not so simple in the former instance as in the latter. In the culture-medium containing the bacteria to be acted upon every germ comes under the influence of the germicide; in the wound, on the contrary, the germs may be entangled in the secretion and dirt, which the disinfectant can hardly penetrate, the strength of the solution is weakened by the secretion from the wound, and the time necessary for the strongest solutions to act is too long to make it safe to use them. The influence of dirt and fatty substances is shown by the laboratory experiments with silk threads impregnated with pus-coeci and then dipped in oil, for such threads have

<sup>1</sup> Mittheilungen aus dem Kaiserl. Gesundheitsamt, 1884, Bd. ii. S. 145.

<sup>2</sup> Annales de l'Institut Pasteur, 1888, t. ii. p. 60.

<sup>3</sup> Zeitschrift f. Hygiene, 1890, Bd. ix. S. 404.

<sup>4</sup> Corrosive Sublimate as a Disinfectant against the *Staphylococcus Pyogenes Aureus*, Bulletin Johns Hopkins Hospital, 1891, vol. ii. p. 50.

been suspended in a 1 : 2000 solution of sublimate for days and even weeks without killing the bacteria (Schimmelbusch<sup>1</sup>).

The alkalis, ammonia, calcium hydroxide, and sodium, in solution, require a much longer time to disinfect, the strength and time being too great and long to make them of practical use. This is equally true of the acids. Thus, the much-used saturated solution of boric acid fails to kill pus-cocci in two hours; but Miguel asserts that it acts as an antiseptic in the proportion of 1 : 143. However, for the practical purposes of antiseptics, boric acid is of no value. Sulphuric acid (1 : 200) kills pus-cocci in two hours. A two-per-cent. solution of salicylic acid destroys pus-cocci in two hours. Absolute alcohol has no effect upon anthrax spores after exposure to it for one hundred and ten days (Koch). Tuberculous sputum was not disinfected with an equal proportion of absolute alcohol after twenty-four hours; in five parts to one of sputum, it destroyed the bacillus in twenty-four hours (Schill and Fischer, *loc. cit.*). Its action upon pure cultures of the bacilli is more effective, as Yersin succeeded in killing them by a few minutes' exposure to it. Of the aniline dyes, methyl violet (Merk's pyoktanin) is said to restrain the growth of staphylococcus pyogenes aureus in solutions of 1 : 2000. The staphylococcus pyogenes aureus, streptococcus pyogenes, and bacillus anthracis were killed in thirty seconds by a 1 : 1000 solution of it (Jacnicke<sup>2</sup>). Boer<sup>3</sup> found malachite green more effective than pyoktanin. Creosol destroyed staphylococcus pyogenes aureus in five minutes in a three-tenths-per-cent. solution; a two-per-cent. solution of carbolic acid, on the other hand, required fifteen minutes to do this (Fränkel). Oil of turpentine added in excess to a liquefied gelatin culture of staphylococcus pyogenes aureus failed to destroy this coccus in five hours (Von Christmas-Direkinck Holmfeld). Iodol failed to destroy anthrax spores in eighty days when added in excess to water (Koch). Hydrogen peroxide, chlorine, and chloroform cannot claim to be practical germicides. The 1 : 500 aqueous solution of iodine with potassium iodide destroys staphylococci of pus after two hours' exposure (Sternberg<sup>4</sup>). Most bacteria are not injuriously affected by the vapor of iodoform. Randolph,<sup>5</sup> of Baltimore, Maryland, found that a pure culture of the staphylococcus albus was not affected by exposure for twenty minutes to the action of absolute alcohol (98 $\frac{1}{2}$  to 99 $\frac{1}{10}$  per cent.).

Low temperatures restrain the growth of bacteria, but do not kill them; some species being capable of multiplying at the freezing temperature.

*Dry Heat.*—Koch<sup>6</sup> and Wolffhügel (1881) showed that to destroy microorganisms in a dry state a higher temperature is required than when they are in a moist state or when they are exposed to the action of steam or hot water.

<sup>1</sup> Aseptische Wundbehandlung, 1893, 2d ed., S. 38.

<sup>2</sup> Fortschritte der Medicin, 1890, Bd. viii. 12.

<sup>3</sup> Zeitschrift f. Hygiene, 1890, Bd. ix.

<sup>4</sup> Manual of Bacteriology, 1892.

<sup>5</sup> Transactions of the American Ophthalmological Society, July, 1896.

<sup>6</sup> Untersuchungen über die Desinfection mit heisser Luft, Mittheilungen aus dem Kaiserl. Gesundheitsamt, 1881.

*Moist Heat.*—Boiling water has the greatest germicidal power. While there is no essential difference in the disinfection power between flowing steam and confined steam at the same temperature, flowing steam is the more effective because of its penetrating fabrics more quickly, and superheated steam is not so powerful as steam under pressure at a higher temperature than 100° C. Flowing steam kills the spores of all known pathogenic bacteria in from five to fifteen minutes. Hot air, on the other hand, requires, according to Koch and Wolffhügel, one and one-half hours to kill bacilli free from spores, while the spores of bacilli are destroyed only after three hours by a temperature (hot air) of 140° C.

*Thermal<sup>1</sup> Death-Point of Bacteria (Non-Spore-Bearing), Moist Heat: Time of Exposure, Ten Minutes.*

	Centigrade.	Fahrenheit.
Staphylococcus pyogenes aureus . . . . .	58°	136.4°
Staphylococcus pyogenes citreus . . . . .	62	143.6
Staphylococcus pyogenes albus . . . . .	62	143.6
Streptococcus pyogenes . . . . .	54	129.6
Micrococcus Pasteuri . . . . .	52	125.6
Gonococcus (in pus) . . . . .	60	140.0

*Boiling Water.*—The spores of bacillus anthracis are killed by boiling in water for two minutes, and the vegetative forms, bacilli and cocci, are killed in from one to five seconds (Schimmelbusch<sup>2</sup>).

#### EXPERIENCE OF OPHTHALMIC SURGEONS RELATIVE TO THE VALUE OF ANTISEPSIS.

The solution most in favor with ophthalmic surgeons is the sublimate. Priestley Smith,<sup>3</sup> of Birmingham, England, has better results after cataract extraction now than he had twelve or fifteen years ago. He attributes the improvement to several causes,—to greater skill in manipulation and longer experience in dealing with difficulties, and to increased care to avoid septic conditions of hands, instruments, solutions, and the surface of the eye itself. "I believe that every irritation of an operated eye is to be avoided, and that the most formidable irritation is that produced by the introduction of microorganisms. I believe also that the ultimate result of such irritation will vary with the resisting power of the tissues of the eye. I therefore strive for aseptic conditions, for a minimum of violence and disturbance of the eye and patient, and for such constitutional conditions as will favor the vitality and resisting power of the tissues. On the other hand, it does not seem to be proved that the so-called antiseptic solutions, so freely used by some surgeons, are necessary for the cleansing of instruments, or are able to destroy organisms in or on living tissues without doing serious damage to the tissues themselves." He carefully cleanses the lids and face; a few drops of perchloride solution (1 : 5000) are instilled between the lids; each instrument is dipped into boiling water, assiduously dried and polished on a clean cloth,

<sup>1</sup> Sternberg, loc. cit., p. 147.

<sup>2</sup> Loc. cit., p. 35.

<sup>3</sup> Letter to the writer.

and laid on a folded cloth in a tray ; hands are thoroughly washed with soap and water. At the close of the operation a little finely powdered iodoform is dusted on the eyeball in the region of the incision. He says that he sometimes omits the iodoform and gets equally good results. He never boils his instruments.

Ole Bull,<sup>1</sup> of Christiania, has had better results in his operations since he began to use antiseptics. He has had suppuration after cataract extraction only once. He boils his instruments, instils solution of sublimate 1 : 2000, and washes the lids and surroundings of the eye with the same solution. Lately he has abandoned the use of sublimate.

Knapp cleanses his instruments in boiling water and instils a sublimate solution of 1 : 5000. This is the practice of some of the ophthalmic surgeons in New York.

Landolt<sup>1</sup> (Paris) sterilizes his instruments by placing them for forty minutes in a solution of oxycyanide of mercury 1 : 100 or 1 : 200, and washes his hands first in a sublimate solution of 1 : 500 and then in one of 1 : 5000, passing his hands finally into *sterilized gloves*. These gloves are cloth pockets, and are intended as a substitute for a towel in drying the hands.

De Wecker<sup>1</sup> says that since he has used antiseptic precautions in cataract extraction his results have been much better ; whereas formerly he had suppuration once in two hundred or three hundred cases, now he has scarcely one in six hundred or eight hundred. He washes his instruments in absolute alcohol, and places them for half an hour in two-per-cent. carbolic acid solution ; just before operating he plunges his instruments into boiling water.

E. Meyer<sup>1</sup> (Paris) says that since he has employed antiseptic precautions in cataract extraction suppuration is no longer met with in his practice. He boils his instruments in water ; for irrigation of the eye he uses a sublimate solution ; during the operation he never uses the sublimate solution, but, instead of it, sterilized water.

Schweigger<sup>1</sup> sterilizes his instruments with a four-per-cent. solution of carbolic acid, and washes the eye with sublimate solution 0.05 per cent.

Chibret<sup>2</sup> uses a ten-per-cent. solution of cyanide of mercury for sterilizing instruments. The instruments are left for ten minutes in this solution ; they are next placed in a 1 : 1500 solution. He washes out the conjunctival sac with the same solution.

Nuel<sup>3</sup> washes the face about the eye with soap and water, followed by a solution of sublimate, taking special care to cleanse the margins of the lids. But he points out the narrow limits of the power of chemical disinfectants, showing that by their aid neither sterilization nor complete asepsis of the conjunctival sac is possible.

Panas<sup>4</sup> still employs his solution of biniodide of mercury (biniodide of

<sup>1</sup> Letter to the writer.

<sup>3</sup> Le Mercredi Méd., 1893, No. 20.

<sup>2</sup> Arch. d'Oph., t. xii. p. 433.

<sup>4</sup> Maladies des Yeux, 1894, t. i. p. 580.



mercury five centigrammes, absolute alcohol twenty grammes, sterilized distilled water one litre). This solution, as has been shown, kills pus-cocci only after two or three days (Weeks); hence it has no practical value as a germicide for ophthalmic purposes.

Schmidt-Rimpler<sup>1</sup> asserts that chlorine water (aqua chlorata of the German Pharmacopœia) has strong disinfecting qualities,—*i.e.*, that it kills pus-cocci in one minute. But this solution irritates the conjunctiva even more than the sublimate solution commonly employed, and the irritation lasts longer; it is objectionable also on account of its irritating odor giving rise to coughing, thus making its application harmful where disinfection is most needed,—*i.e.*, in cataract extraction; it is also easily decomposed.

The strength of sublimate solution most used in ophthalmic practice is 1 : 5000. This solution kills pus-cocci in from two and a half to three minutes, according to Weeks, but according to Schmidt-Rimpler<sup>2</sup> not until after three minutes; and Abbott<sup>3</sup> states that even a 1 : 1000 solution of sublimate does not always destroy the staphylococcus pyogenes aureus after twenty-five minutes. The skin of the lids may be disinfected by means of dressings, because these may be kept in contact with this surface sufficiently long to accomplish their object; but the circumstances are different when we come to disinfect the conjunctival sac, for we cannot here keep the antiseptic sufficiently long in contact with the parts to accomplish antiseptis without at the same time doing mischief to the eye. When the antiseptic is simply dropped into the eye, the secretion of tears is accelerated, and the solution is diluted and finally washed out of the eye.

#### CAN WE RENDER THE CONJUNCTIVAL SAC ASEPTIC?

It has been stated by numerous ophthalmic surgeons that irrigation of the conjunctival sac during and after an operation on the globe has proved to be of great value; however, we must not overlook the fact that the action of these washings may be *mechanical* rather than chemical,—*i.e.*, the micro-organisms are washed away and not killed.

Gayet, who was the first to investigate the question of ocular antiseptis, experimented upon a series of one hundred and seventy-eight eyes taken at hazard, by washing out the conjunctival sac with a sublimate solution of 1 : 6000. After the washing a sterilized platinum wire was passed over the conjunctival surface and then dipped into a suitable culture-medium contained in test-tubes. It was found that, in spite of the washing with sublimate, one hundred and thirty-nine tubes were fertile and thirty-nine sterile. In this series there was suppuration eleven times. In another series, of thirty-six cases, the conjunctival sac was washed out with a saturated solution of boric acid; only three tubes remained sterile. Thus, in two hundred and fourteen cases, in spite of washing of the conjunctival sac,

<sup>1</sup> Aqua Chlorata zur Desinfection bei Augenoperation und Augenverletzungen, Deutsche Med. Wochenschrift, 1891, No. 31, S. 945.

<sup>2</sup> Loe. cit., p. 945.

<sup>3</sup> Loe. cit.

one hundred and seventy-two eyes contained microbes. Gayet also, by methodical pressure, endeavored to press out the contents of the Meibomian glands. Gayet's experiments thus showed that it was not always possible by simple irrigation of the conjunctival sac to render this part germ-free, and further showed that freedom from germs was not always necessary to an exact healing of the wound in the cornea.

Franke<sup>1</sup> made one hundred and thirty experiments, as follows. In ten cases he washed the conjunctival sac with solution of sublimate 1 : 5000 ; in fifty he wiped the upper and the lower cul-de-sac with sterilized cotton dipped in the solution of sublimate and then washed the surface with the same solution ; in fifty he washed out the conjunctival sac with aqua chlorata, undiluted, as recommended by Schmidt-Rimpler ; in ten he washed and wiped the conjunctival sac with triehloride of sodium (Pflüger's method) 1 : 2000 ; and, finally, in ten he washed and wiped the conjunctival sac, according to Edward Meyer, with sublimate solution 1 : 2500. The temperature of the solution was from 30° to 35° C. Franke could not be certain that the region of the operation would be rendered germ-free by any of these methods. The most satisfactory method was that which combined the *wiping* of the surface with the irrigation. The most unsatisfactory cases were those in which the conjunctival sac was simply irrigated with the sublimate solution 1 : 5000. If microbes were demonstrated in the conjunctival sac, they were always present after the simple irrigation.

Stroschein<sup>2</sup> found that the results obtained by irrigation with a solution of sodium chloride 0.6 per cent., sterilized by boiling, did not differ from those obtained with the sublimate solution. He shows that if germs were numerous in the conjunctival sac before irrigation with the salt solution, there was always a pronounced diminution after it, and this diminution in the number of germs was the more pronounced the oftener the irrigation was repeated. If there were, as was generally the case, but few micro-organisms present, he almost never found any after irrigation.

Alfred Graefe, who washed his cataract eyes before and during the operation with a sublimate solution 1 : 5000, believes that the sublimate was the cause of the marked permanent opacity of the cornea in 4.7 per cent. of all his cases. Absolute disinfection was no more obtained with the sterilized salt solution than with the sublimate.

Genderen Stort proved that the bacteria in the conjunctival sac were washed away by the tears ; when the flow of tears is obstructed, or the quantity of the conjunctival secretion is so much increased that the tears no longer suffice to carry off the secretion through the tear-passage into the nose, this mechanical action of the tears is restricted. The absence of irritation, therefore, is favorable to the aseptic healing of the wound.

---

<sup>1</sup> Von Graefe's Arch. f. Oph., 1893, Bd. xxxix., Theil iii., S. 4.

<sup>2</sup> Ibid., Bd. xxxix., Theil i., S. 261.

The writer's conclusions, deduced from experiments with chloride of sodium in solution, agree in the main with those of Strosehein, except that I believe that the effect of washing and wiping the conjunctival sac, and especially the site of the incision, is far greater than he states it to be. I obtained better results, no doubt, because the irrigations were practised daily for a week before the operation and the final test for germs. I did not succeed in obtaining an ideal sterilization of the conjunctival sac in any instance in which bacteria were numerous in the conjunctival sac (one hundred and forty cases). Nevertheless, all the evidence favors that mode of procedure which produces by the simplest non-irritating means the cleansing of the conjunctival sac.

Intra-ocular antiseptics following operations on the eye—*i.e.*, cataract extraction—is mentioned only to condemn it. The only agent permissible in washing out the anterior chamber is a sterilized solution of sodium chloride 0.5 per cent. The most experienced ophthalmic surgeons testify that their results are better since they have employed antiseptic precautions in their operations. Of course we must not overlook the value of skilful operative technique as a factor in preventing infection of a wound, as in cataract extraction; but the best results are not to be expected, as Steffan<sup>1</sup> assumes, from the technique alone. In his operations, Steffan cleansed his cataract-knife and the rest of his instruments in boiling water after they had been "dipped" in a Laplace solution (tartaric acid and sublimate). A dressing saturated with this solution was kept on the eye for one hour before the operation. He washed the conjunctival sac before and after the operation with a sublimate solution of 1:5000, dusted the wound with iodoform, and bandaged the eye with cotton-wool dressing dipped in the Laplace solution (sublimate 1, tartaric acid 5, distilled water 1000). One hundred and four extractions were done under these precautions, and there was a loss of 6.73 per cent. from septic influence. Compared with these results, he did four hundred and twenty-six extractions without antiseptics, only observing "careful cleanliness." The loss was 6.5 per cent. It is upon these results that Steffan bases his opinion as to the uselessness of antiseptics. Alfred Graefe practised the same operative technique, and through antiseptics reduced the loss to 0.93 per cent. from suppuration in ten hundred and seventy-four extractions.

We do not know at what time the corneal wound has so far closed that it may not be infected. A few examples show that at the end of the first or even of the second week, even where healing had apparently progressed favorably up to that time, suppuration has set in. This experience shows that under certain conditions the tissues of an operated eye may for a considerable time remain disposed to develop pathogenic elements. However, as a rule, the conditions favoring infection are mostly removed soon after the operation. We shall have done all that it is at present possible to accom-

---

<sup>1</sup> Von Graefe's Arch. f. Oph., 1893, Bd. xxxv., Theil ii.

plish by means of antiseptics or asepsis when we have used perfectly aseptic instruments and carefully cleansed the conjunctival sac and the site of the operation with a fluid which shall not interfere with the conditions necessary for a normal healing of the wound.

#### IMPORTANCE OF CLEAN INSTRUMENTS.

Stroscheim took twelve Graefe knives fresh from the instrument-maker, and thrust the whole length of the blade of each one into a culture-medium contained in tubes and placed the latter in an incubator. The gelatin was carefully fluidified and run onto plates. Only three tubes remained germ-free. The majority of the plates showed *Sarcina lutea*; next came the potato bacillus (*Bacillus mesentericus vulgaris*), and two unknown kinds of micrococci. The same knives four weeks later, after having in the mean time been used and for this purpose disinfected, were absolutely sterile, in spite of the fact that some of them had lain for weeks in their cases. Of six Graefe knives which had been used during six months on the cadaver and on pigs' eyes, only one was infected, and this was found to be rusty. I have tested eight Graefe knives, five keratomes, and six capsulotomes which were cleansed by wiping with cotton-wool and boiling in water. After having lain in the operating-case untouched for six months, all the knives and keratomes were found to be sterile.

Stroschein found that of five Beer's knives only two remained sterile in the operating-case. He believes this to have been due to the dirt collected in the letters of the manufacturer's name stamped on the shank. Instruments with uneven surfaces always require vigorous scrubbing. The same writer found that Graefe's and Beer's knives infected with pus or pure cultures of *Staphylococcus pyogenes aureus* or a saprophytic bacillus (very difficult to kill), allowed to dry on the blade, could be made sterile by wiping the blades vigorously a number of times with cotton-wool dipped in a mixture of equal parts of alcohol and ether and a few drops of ammonia, the blades being drawn through the cotton under firm pressure ten or fifteen times and finally wiped and rubbed for a minute with cotton wet with a five-per-cent. solution of carbolic acid, the handles being treated in the same way. The knives were finally laid in a sterilized solution of sodium chloride, for the purpose of washing off the antiseptic. Knives thus treated were found to be completely sterile.

These solutions of ammonia, ether, and carbolic acid damage the cutting edge of our instruments. I have succeeded in sterilizing Graefe's knives which had no scratches by several times dipping the blades into a one-per-cent. boiling solution of soda and wiping them under firm pressure with clean cotton-wool. Instruments with scratches and other irregularities cannot be certainly sterilized in this way; they must be boiled.

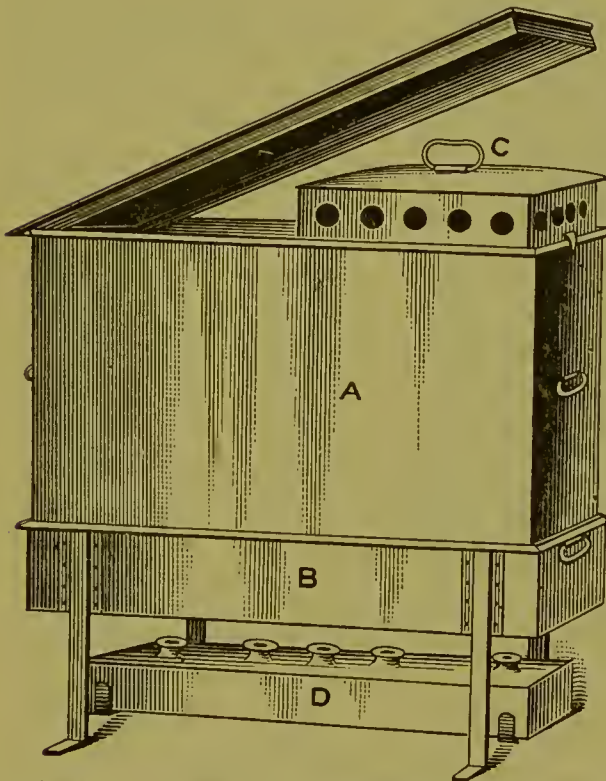
It is of the greatest importance that the capsulotome and dissection-knife should be beyond the possibility of infecting the eye. Many eyes have been lost in the division of a secondary cataract because the instrument used for

the purpose was not clean. Trousseau<sup>1</sup> says that, although he has been able to perform more than three hundred extractions without a single case of suppuration, he had lost from purulent panophthalmitis one eye in sixteen operated upon by discission (6.25 per cent. of loss); and Chevallereau, in the same institution, had 1.48 per cent. of purulent panophthalmitis after his extractions and 9.09 per cent. after discission. It is evident that, if the knife be contaminated, there is greater danger of infecting the eye in discission, where the instrument passes deep into the eye and the wound made by it closes as soon as the instrument is withdrawn, than when a large wound is made, as in cataract extraction, in which the aqueous humor escapes.

#### PREPARATION OF DRESSINGS.

Streaming steam is sufficient for all purposes of disinfection of surgical dressings, but in order that the steam shall have sufficient action it must be

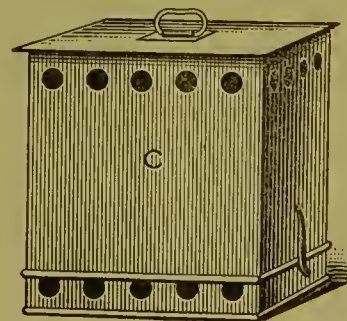
FIG. 1.



Apparatus for sterilizing dressings and instruments (Schimmelbusch).—A, space for sterilizing dressings by steam; B, tray containing solution of soda, one per cent., for sterilizing instruments; C, removable kettle for dressings; D, spirit-lamp.

saturated; in this condition it drives all the air out of the dressings, thus enabling the steam to act rapidly. Koch's steam-boiler makes a good sterilizer for dressings. It consists of a cylindrical tin vessel in which a certain amount of water is placed, the level of the latter being separated from the dressings by a net-work partition.

FIG. 2.



Kettle.

The vessel is supplied with a close-fitting lid. When the water boils, the steam rises through the network, drives the air out of the space to be disinfected, and is forced under light pressure against the closed lid. If

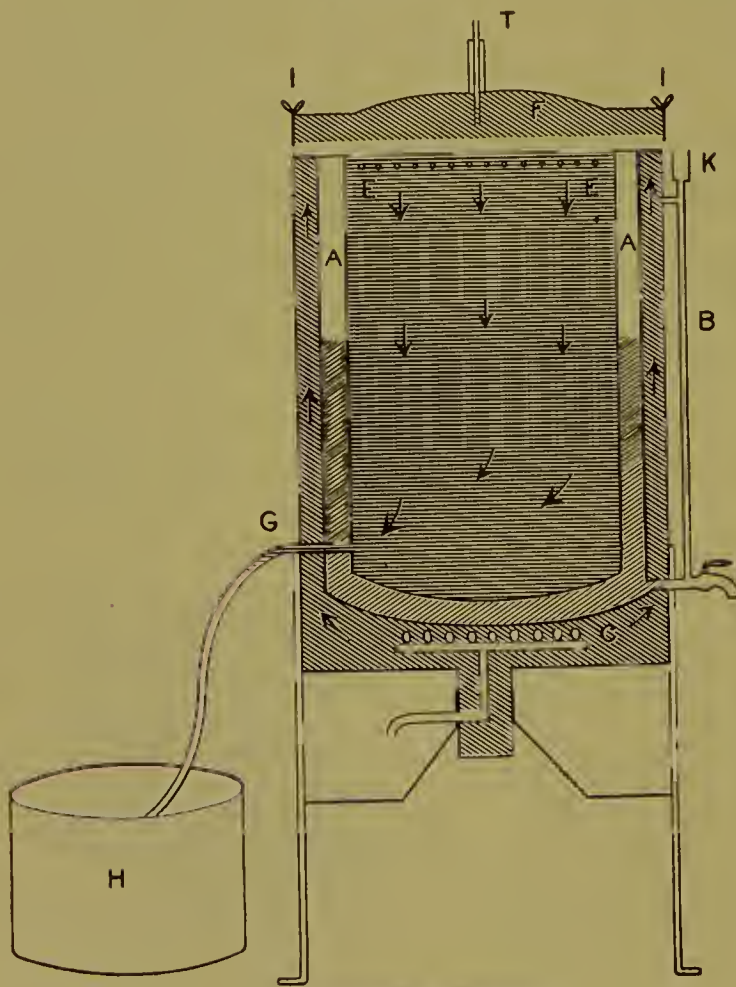
<sup>1</sup> *Compte-rendu de la Clinique des Quinze-Vingts, 1890-1891, p. 23.* Quoted by Landolt, *Der gegenwärtige Stand der Staaroperation, Beiträge zur Augenheilkunde, 1892, p. 61.* Translated by C. Culver, M.D., in *Ophthalmic Record, November, 1892, p. 178.*

there be a very active supply of steam in such an apparatus of proper proportions, the air is driven off and there will not be any condensation while the apparatus is operating. But while the water is being heated, if the dressings have not previously been warmed, there will be considerable condensation of steam and the dressings will be wet.

Schimmelbusch has devised a combination apparatus for sterilizing dressings and instruments. (See Fig. 1.) The steam from the boiling soda solution in *B* penetrates to the dressings through the holes in the kettle *C*. (See Fig. 2.)

The larger apparatus of Lautenschläger (see Fig. 3) does its work under slight overpressure, which insures quick and complete penetration of the dressings by the steam, equable temperature, and avoidance of condensation.

FIG. 3.



Lautenschläger's apparatus.

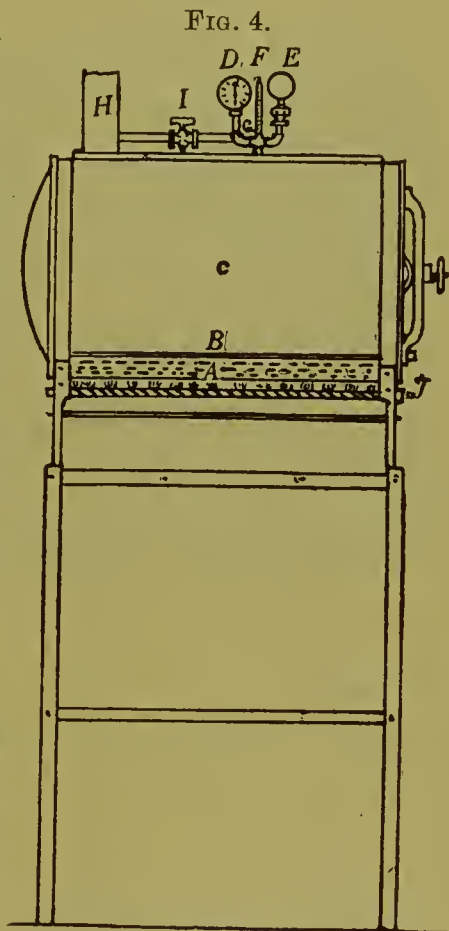
An overpressure of one-fifth of an atmosphere, which is obtained with the large apparatus used in hospitals, gives a temperature of  $102^{\circ}$  C. Lautenschläger's apparatus consists of two copper cylinders, one within the other, the outer cylinder being covered with a mantle of asbestos. The space *A*, several centimetres wide, between the external and internal cylinders, is half filled with water, the water-level, *B*, indicating the amount of water contained in the space *A*. The water is boiled by means of gas-jets at *C*. The steam rises in the space *A* and enters the space containing the

dressings from above through the openings at *E* in the inner cylinder. When the lid *F* of the apparatus is closed, the steam cannot escape above, but flows downward in the direction indicated by the arrow, and leaves the sterilizing space by the opening *G*, whence it passes through a coil of lead pipe to be condensed in a cooling vessel, *H*, filled with water. The lid *F* can be hermetically closed by means of screws at *I*. A thermometer is placed at *T*. The space *A* is filled with water through the water-registering

glass column, *B*, by means of a funnel at *K*. When the water in the space *A* is heated, and before steam is generated, the space *D* and the dressings within it are heated, so that when the steam does enter this space the dressings are already warmed. With a tight-fitting lid (*F*) and a small exit-pipe (*G*), a temperature of 100° C. (212° F.) is attained, with a slight over-pressure amounting to twenty-six millimetres,—*i.e.*, one-thirtieth of an atmosphere (Schimmelbusch). In three-fourths of an hour from the moment the closed apparatus shows a temperature of 100° C. all the dressings are sterilized. The steam which flows from the apparatus at *G* may be collected and condensed in a cooling vessel (*H*), or, when running water is available, the steam may advantageously be led to a cooling vessel and from it to a condenser. By this means the distilled water in the condenser may either be returned to the sterilizer or used as sterilized water in the operation. Lautenschläger has devised a very simple attachment to his steam-sterilizer for condensing the steam which escapes. The apparatus may be heated by gas or spirit-lamp, or, where streaming steam is available, as in a hospital, the larger-sized apparatus may be operated by connecting it with the steam-pipe.

The most approved sterilizer for dressings is that made by Richard Kny & Co., of New York. Their No. 3 is the standard size, being fourteen inches in diameter and twenty-three inches long. It is cylindrical in form, placed horizontally, and rests upon an iron frame. The cylinder is made of heavy cold-rolled copper. One end, or head, is permanently fixed to the cylinder; the other, holding the door of entrance to the sterilizing chamber, is of cast bronze. The door is fastened by a single yoke and screw, and is made steam-tight by the accurate fitting of the articulating surfaces. The apparatus furnishes a moist temperature of 228½° F. at a steam-pressure of five pounds, and the apparatus would resist a much higher pressure if it were required. The arrangement of the apparatus is such that the dressings are *dry* when sterilization is complete, a desideratum of the greatest importance.

Fig. 4 shows a longitudinal section of this sterilizer. The lower section of the cylinder is arranged to receive about one gallon of water, which is converted into steam by gas heat, or, if the apparatus be connected, with the steam of the house or hospital. This conversion is effected by means

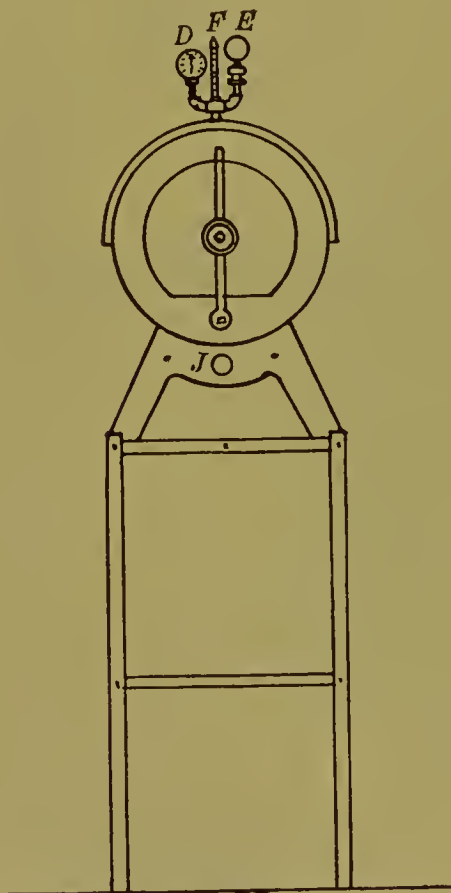


Sterilizer for dressings. Longitudinal section.

of a steam circulating coil. The water section is indicated by *A*, *B* being the open shelf or rack upon which rest the articles to be sterilized, either in wire cages or boxes (Fig. 8), the latter being used to insure safe conveyance of the dressings to wards or operating-rooms. *C* is the sterilizing chamber, *D* the pressure-gauge, *E* the safety-valve, *F* the thermometer, *G* the atmosphere filter and vacuum-valve, *H* the vapor-pipe, *I* the relief valve, *J* the gas-burner. Fig. 5, front elevation, shows the door and its fastenings.

Figs. 6 and 7 show the same firm's water-sterilizing tanks. The latest design is drawn from a block of copper. It is made in one piece, except-

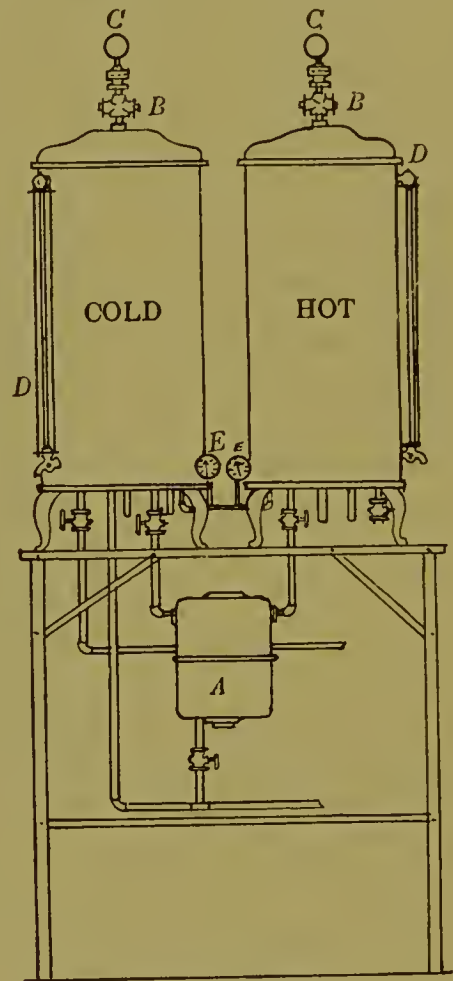
FIG. 5.



Sterilizer for dressings, front elevation.

FIG. 6.

FIG. 7.



Water-sterilizing tanks.

ing the lid, which is brazed in. The tanks are tested to 150 pounds hydraulic pressure to the square inch. They are heated either by steam or gas. Contamination of the contents of the tanks is avoided by cutting off the water-supply to them and by the use of an air-filter and valve. The vacuum is overcome by the atmosphere passing through this filtering valve before entering the tanks. Therefore, the water which is obtained from these tanks is first filtered and then sterilized. The "cold tank" is supplied with means for rapid cooling of the water after its sterilization. *A* is the water-filter, *B* the atmosphere-filter and vacuum-valve, *C* the safety-valve, *D* the water-registering glass column, *E* the pressure-gauge. The capacity



of these tanks is twenty-five, fifty, seventy-five, and one hundred gallons respectively.

The case (Fig. 8) for holding surgical dressings while undergoing the sterilizing process, and for their safe conveyance from the sterilizer to the operating-station, is made by Richard Kny & Co., of New York, according to Schimmelbusch's suggestion. There are two sizes, three inches in diameter and six inches long and six inches by six inches. It can, however, be obtained of any size required. The tubular shape is preferable, but it is also made square. At *a* and at *b*

is a row of holes through which the steam enters while the case is in the sterilizing chamber. After sterilization and withdrawal of the case from the sterilizer, these holes are closed by sliding the band of metal over them. Another pattern, of the same shape and size, consists of two sections, an inner and an outer, the latter sleeving tightly over the former. The withdrawal of the outer section a half-inch (as shown in Fig. 2) exposes the small openings, through which the steam readily finds its way to the dressings. Before taking the case

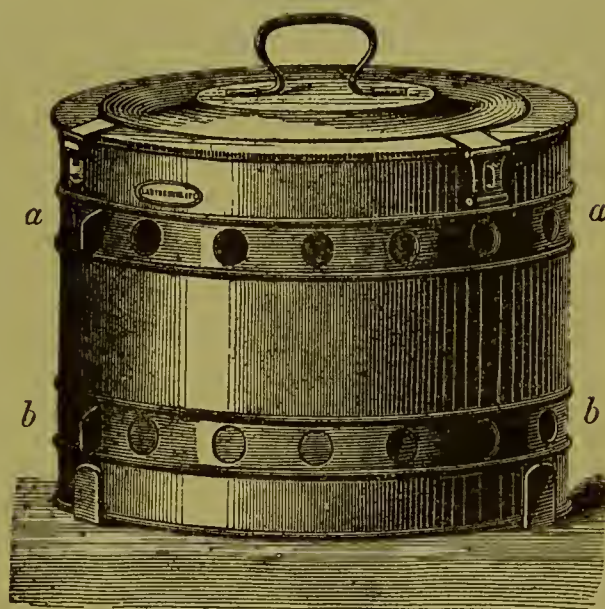
from the sterilizer the holes are covered by simply pressing the two sections together. The case is now practically hermetically sealed, and can be taken to the ward, to the operating-room, or on a journey without danger of contaminating the dressings within.

This is the most efficient means of sterilizing surgical dressings. The saturation of surgical dressings with chemical disinfectants is no more efficient than the sterilization of the same effected by heat, provided the dressings be perfectly dry. *Dryness* is the enemy of the life principle of lower germs, while *moisture* is that life principle itself. Thus, dressings sterilized by heat have all the advantages of those prepared with chemical disinfectants, without their disadvantages, as they do not, like the latter, irritate the wound-surface.

#### PREPARATION OF THE PATIENT, OPERATOR, AND INSTRUMENTS.

In hospital practice, the patient about to undergo an important surgical operation—*i.e.*, cataract extraction—should be given a warm bath, and in all similar instances in private and public practice a cathartic should, unless contra-indicated, be administered the day before the operation.

FIG. 8.



Case for surgical dressings.

The operator's hands and nails and those of his assistants should be thoroughly cleansed by liberal use of warm water, soap, and nail-brush. The brush is best sterilized in the steam-sterilizer, and kept ready for use in a solution of *bichloride of mercury*, 1 : 2000.

The bacteria of the surface of the skin lie embedded in fat particles and dirt and the recesses of the cutaneous surface. These things, together with the dead organic material, etc., found on the surface of the body, and in which bacteria are concealed, render the process of disinfection of the hands a complicated and difficult one. We have seen that bacteria enveloped in fat particles are much more difficult to reach and influence by chemical disinfectants than are those in pure cultures in the laboratory. Therefore, when we consider the length of time necessary to destroy some of these low organisms—even in pure cultures—by means of chemical disinfectants, it is self-evident that the simple dipping of the hands into the strongest germicide is useless, so far as disinfection is concerned, and that it is necessary to cleanse the surface mechanically before germicides can be expected to be of any use in disinfecting the hands. The first and most efficient agent in this mechanical process of removing dirt containing bacteria of the skin is a liberal use of soap and warm water. The length of time necessary to devote to this scrubbing of the hands will, of course, depend on the sensitiveness of the skin and the skill of the person in handling the brush; for, simple as it may seem, it requires some practice properly to scrub the hands and nails without injuriously disturbing the cutaneous surface.

In Bergmann's clinic the *disinfection of the skin* is done in the following manner. (1) The skin is energetically scrubbed with warm water (as warm as can be comfortably borne) and soap for at least one minute. (2) The skin is dried and rubbed with a sterilized towel or gauze. The under surfaces of the nails receive especial attention, because Fürbringer and others have shown that these are the parts of the hands which are most rich in germs. (3) The skin is rubbed for one minute with eighty-per-cent. alcohol by means of sterilized gauze. (4) The skin is irrigated and rubbed with a solution of bichloride of mercury, 1 : 2000. When the skin is very dirty it is advised to rub the skin with ether before applying the disinfectant.

The surgeon should always repeat the disinfection of his hands after every examination or operation in which he touches infected material,—*i.e.*, a suppurating wound,—not alone for his own personal security, but, as Schimmelbusch properly says, more to prevent infection germs from “nestling in and adhering to the hands.”

A soap should be selected which has undergone cooking in the manufacture; and those soaps should be avoided which are made with cold fats and lye.

The patient's face about the eye to be operated upon—*i.e.*, the eyebrow and eyelids—should be energetically scrubbed with absorbent cotton armed with soap and warm water. The edges of the eyelids and cilia should

receive especial attention. Grasp the edge of first the upper and then the lower eyelid between the index finger and the thumb, and repeatedly draw them over the edge of the lid and the cilia. In this way we mechanically cleanse the cilia and detach those which may be loose, and at the same time squeeze out any plugs of secretion which may be in the opening of the Meibomian follicles. These parts are then washed with plain boiled water.

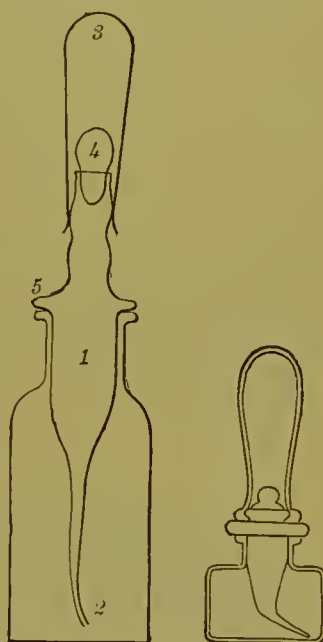
The conjunctival surface is next washed with solution of *sodium chloride*, 0.5 per cent., which has been sterilized by boiling. This solution is less irritating than plain water. The lids are everted, and the surface of the conjunctiva and the site of the operation are gently wiped with aseptic absorbent cotton which has been dipped in the warm sterilized salt solution. A small piece of the same absorbent cotton, wound about a cotton-holder and dipped in the salt solution, is passed up into the cul-de-sac while the lid is lifted away from the globe by means of a speculum, and the surface of this part is gently wiped and then freely irrigated with the same solution. The glass bottle (Fig. 9) which the writer devised for washing out cortical matter after cataract extraction serves this purpose very well.<sup>1</sup> The alternate wiping and irrigation accomplish all that it is possible to accomplish in rendering the mucous surface aseptic.

The cocaine solution may be boiled in the bottles which we have devised for this purpose (Fig. 10). Stroschein's<sup>2</sup> bottles are also well adapted for this purpose. Stroschein has calculated that the loss of water by boiling the solution is about 0.8–1.0 cubic centimetre; therefore, when we wish to maintain a certain concentration of the solution, from ten to fifteen drops of water are added to the solution before boiling. The boiling is continued for three minutes.

Instruments which have joints and rough surfaces are thoroughly scrubbed with soap and hot water after an operation; boiling for three minutes in a one-per-cent. solution of soda (sodium carbonate) is then sufficient preparation for the next operation. The advantage of the soda solution is that it prevents the instruments from becoming rusty, as they would if sterilized in steam and plain boiling water. The *capsulotome* and *discission-knife* should receive attention: the point should be examined under a magnifying lens for any collection of blood, rust, etc. The handles

FIG. 9.

FIG. 10.

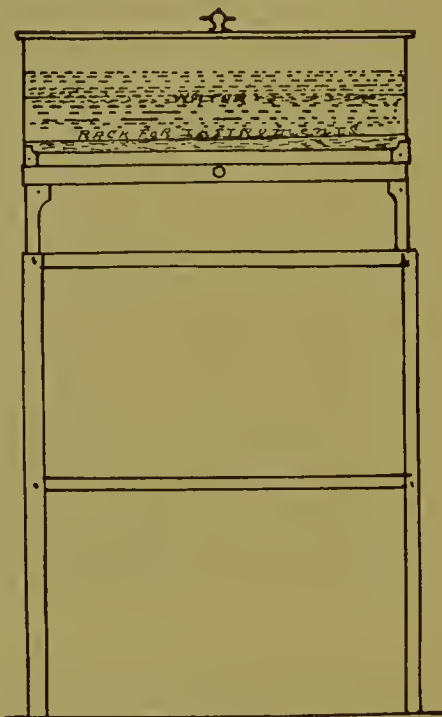


<sup>1</sup> This bottle is not cast in a mould, but blown; therefore the solution may be boiled in it over a spirit-lamp. The glass stopper shown at 4 (Fig. 9) closes the hollow stopper, 1, and prevents the fluid in the bottle from becoming contaminated by contact with the rubber nipple, 3, when the bottle is transported; the collar, 5, protects the mouth of the bottle from collections of dust, etc.

<sup>2</sup> Von Graefe's Arch. f. Oph., 1892, Bd. xxxviii., Heft ii., S. 159.

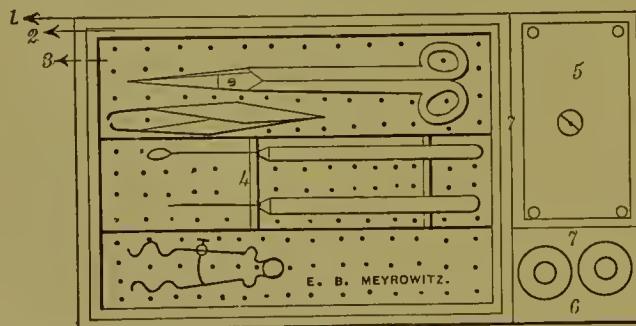
of the instruments to be boiled should be made of aluminum, and nickel-plated, as the aluminum is attacked by the soda solution. Hollow steel handles are preferable. The Graefe cataract-knife need not be boiled; it suffices to dip the blade into the boiling soda solution and wipe it with clean absorbent cotton, this operation being repeated several times. In order to avoid blunting of the cutting edge and point of fine scissors, etc., such instruments should not be allowed to remain in the boiling soda solution.

FIG. 11.



After washing the cutting instruments they should be placed in ninety-five-per-cent. alcohol for thirty minutes. The alcohol does not affect the cutting edge or point of the Graefe knife. After removal of these instru-

FIG. 12.



Ground-plan of writer's sterilizer.—1, outer box containing boiler, 2, and tray, 3, the latter being supplied with a movable rack, 4, for holding instruments (the boiler, 2, has its own cover and is intended for instruments only); 5, lamp; 6 and 7, bottles (see Fig. 10) for solutions.

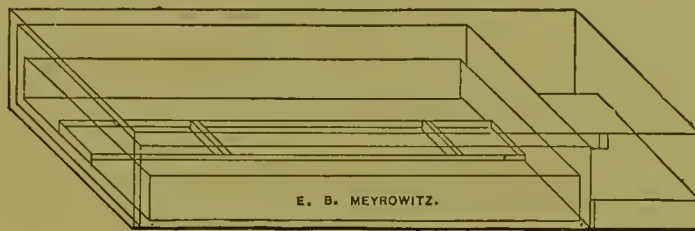
ments from the alcohol they should be dipped into sterilized warm water and gently wiped with a sterilized cloth.

The apparatus used in hospitals for sterilizing instruments in boiling soda solution is shown in Fig. 11, placed on its iron stand. The standard

size is seven inches deep, twelve inches wide, and twenty-two inches long. It is made of copper lined with tin. The instruments while being boiled are placed on a brass tray which is immersed in the solution.

For private practice the writer has devised a portable apparatus for sterilizing instruments in soda solution (Figs. 12, 13, 14, 15), which, because of its small size, is very convenient, the dimensions being as follows: the tray for instruments (Fig. 12, 3) is five inches wide and six inches long; the case (Fig. 15) containing the tray, boiler, lamp, and bottles is eight inches long, five inches wide, and one and a half inches deep.

FIG. 13.



Apparatus enclosed in its case.

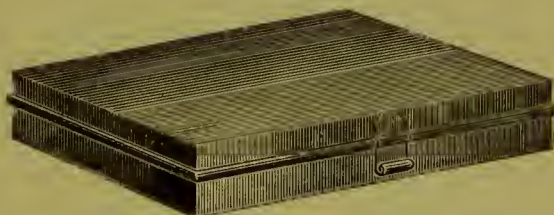
*Directions for using the Writer's Apparatus.*—In preparing instruments for an operation the water is taken boiling from the house-kettle. This is done for the double purpose of saving time and to insure the use of clean water. About five ounces of water containing twenty-four grains of

FIG. 14.



Sterilizer over lamp.

FIG. 15.



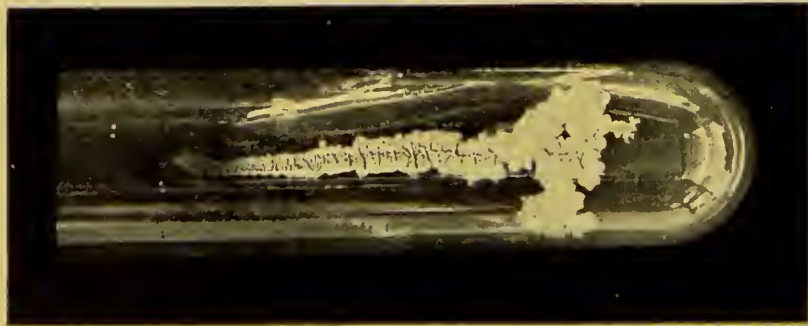
Case containing sterilizer, lamp, and bottles.

washing-soda are poured into the boiler (Fig. 12, 2); the tray containing the instruments is lowered slowly (held by the handle of its lid) into the solution in the boiler; the solution passes readily up into the tray through the holes in its bottom. The boiler is now closed and placed on the stand over the spirit-lamp (Fig. 14). As boiling water was taken in the first place, the solution begins to boil in a few seconds. After boiling for three minutes the lamp is extinguished and the tray is lifted slowly out of the boiler, the solution being allowed to run off into the boiler through the tray's perforated bottom before placing the tray on a clean towel prepared to receive it on the table. In a few seconds the instruments are dry and ready for use.



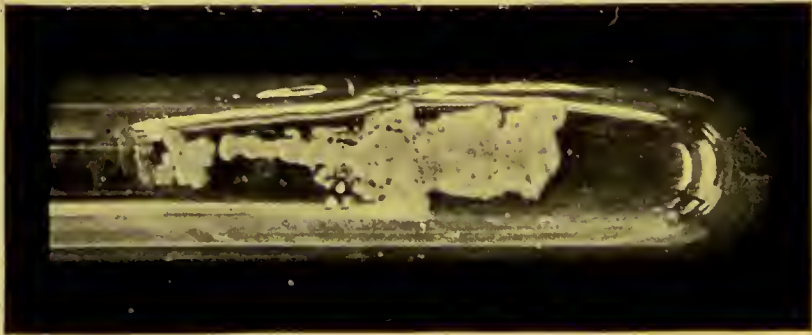


FIG. 1.



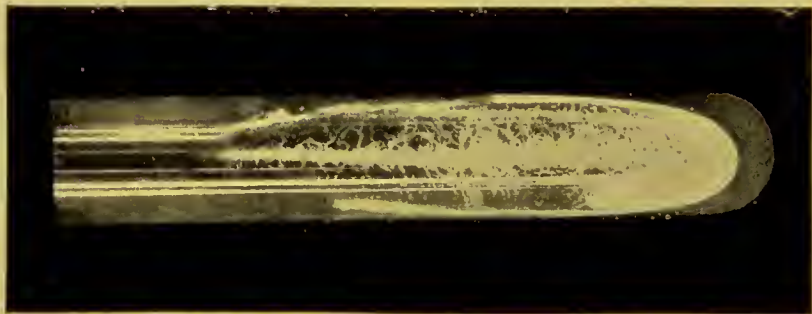
Agar-agar culture of the bacillus  
*mesentericus vulgaris*.

FIG. 2.



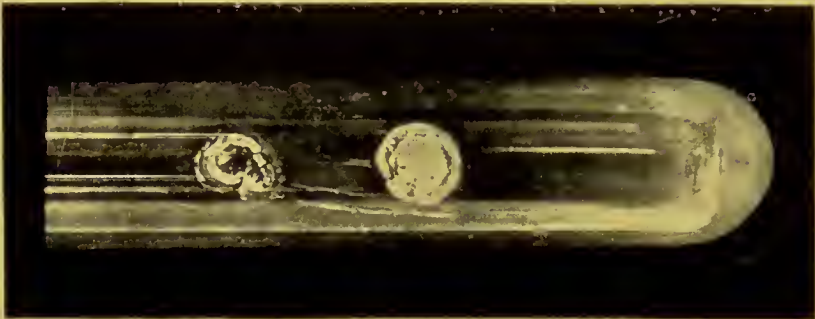
Agar-agar culture of the bacillus  
*megatherium*.

FIG. 3.



Agar-agar culture of the bacillus  
*mycoides*.

FIG. 4.



Agar-agar culture of *cladothrix*  
*dichomata*.

FIG. 5.



Agar-agar culture of the bacillus  
*hirsutus*.



# THE MICRO-ORGANISMS OF THE CONJUNCTIVA AND LACRYMAL SAC.

BY JOSEPH McFARLAND, M.D.,

Demonstrator of Pathological Histology in the University of Pennsylvania; Adjunct Professor of Pathology in the Philadelphia Polyclinic and School for Graduates in Medicine, Philadelphia, Pennsylvania, U.S.A.,

AND

SAMUEL STRYKER KNEASS, M.D.,

Adjunct Professor of Bacteriology in the Philadelphia Polyclinic and School for Graduates in Medicine, Philadelphia, Pennsylvania, U.S.A.

---

*Introduction.*—The relation of bacteria to disease had scarcely planted a distinct footprint in medical science before ophthalmologists realized that that impression pointed in a direction where the explanation of many hitherto ununderstood phenomena might be found.

No considerable study is needed to prove to reasonable men that the moist surface of the conjunctiva, always on that side of the individual exposed to the air and dust as he walks,—rubbed by fingers soiled by the instruments of handicraft, the contact with the surface of the body in health and disease, and sometimes such highly septic material as that from the urethra in gonorrhœa; washed with water from rivers, creeks, ponds, buckets, and all sorts of clean and dirty receptacles; wiped with towels, wash-cloths, handkerchiefs, coat-sleeves, and whatever else comes to hand,—must indeed be a part of the body above all others, scarcely excepting the nose and mouth, open to the lodgement of bacteria. Moreover, the slight alkalinity and small amount of proteid material contained in the normal secretions, as well as the fact that there are folds and crypts in the conjunctival membrane, favor the development of whatever germs accidentally enter, unless, as Bernheim seems to show, the lacrymal fluid is an antiseptic.

But, numerous as are the sources of infection which we have mentioned, they are not all; indeed, they form the least dangerous source of contamination. The presence of micro-organisms upon the conjunctiva not infrequently depends upon infection from the nose through the nasal duct and the lacrymal sac, resulting from the anatomical configuration of the parts, the continuity of the mucous membranes of the eye, lacrymal tract, and nose furnishing a means of conveyance for saprophytic and parasitic (pathogenic) organisms from the eye to the nose, and *vice versa*. It is also asserted

that infection of the conjunctiva may occur from disease of neighboring bones and inflammation of their sinuses, especially the maxillary sinus. It may appear by the conveyance of micro-organisms to the conjunctiva through the blood- and lymph-vessels in cases of disease of remote organs.

The various researches of Sattler, Michel, Fick, Weeks, Shongolowicz, and many others have clearly established the constant presence of numerous harmful as well as harmless bacteria upon the eye, and by this demonstration have shown a factor in prognosis which had not previously been considered. One can prognosticate the result of a cataract operation much less accurately when he knows that the staphylococcus pyogenes aureus is always present in the eye.

The lacrymal sac furnishes a medium of culture almost perfect for many organisms, and is a permanent source of infection which is liable to bring about suppuration processes in traumatic and operative wounds of the eye, in spite of the most rigid antisepsis of the conjunctiva. This is probably one reason of the corneal ulcers following slight wounds; suppuration following cataract operation; tuberculosis conjunctivæ following primary tuberculosis of the sac; conjunctivitis following ozæna, diphtheria, influenza, and measles; and the injection and lacrymation accompanying a coryza.

Many organisms are unable to injure the normal membrane, but once allow them access to a *læsio continui* and they become the source of troublesome infection. Leber has shown how serious may be the results of the growth of comparatively harmless organisms if once they secure a footing in the proper soil, and reason exists why we should believe that keratitis may result from ordinarily harmless bacteria should they gain entrance to the corneal layers.

The work of our predecessors has been comprehensive and thorough, though mostly in special lines. Thus, Gifford, who was one of the pioneers, studied the micro-organisms found upon a large number (twenty-eight) of conjunctivæ affected with phlyctenular conjunctivitis, and succeeded in cultivating seven different micrococci, but no bacilli. Fick investigated eighty-five normal and chronically inflamed conjunctivæ, and succeeded in cultivating seven bacilli and numerous cocci, some of which were pathogenic. Weeks investigated ophthalmia neonatorum and "pink eye," and, in addition to some known organisms which he met, described a specific bacillus of "pink eye" and a few others. Kucharski studied twenty-six trachoma cases, and found, besides the coccus which he thought to be specific, a number of ordinary contaminating forms. Shongolowicz also investigated trachoma, and found a variety of bacteria, harmless and harmful, among them a new bacillus which he supposed to be specific for the disease. The latest papers are those of Hildebrand, Bernheim, and Marthen of Zurich, and contain the description of numerous species.

The work of the above authorities is highly commendable, and, considering the impediments which must be overcome in such investigations, is

remarkable. It is, however, deplorable that so many ophthalmologists have hurried into the bacteriological study of cases with so incomplete a knowledge of the subject as to render their work not only valueless, but, worse than that, an obstacle in the way of others.

The confusion which results from this lack of preparation leads to the hurried publication of supposed discoveries, accompanied by such incomplete descriptions as to hinder further work upon the subject. This state of affairs is particularly observable in the great variety of organisms described as specific for trachoma. As will be seen by referring to the part of our paper which treats of that subject, a large number of descriptions, all varying more or less, have been given of organisms which, when carefully analyzed, prove to be only one or two species after all. It would scarcely be possible for one to describe an organism characteristic of trachoma, at the present time, without the danger of an accusation of plagiarism, for every possible organism has already been described by some one of these enthusiasts.

We do not make these remarks for the purpose of discouraging original work of this kind, but as a caution against the abuse of description which accompanies careless or superficial work. At this time, when so many varieties of bacteria are known, and when so many of them differ only in minute details, the description of them cannot be too complete, and too many of their peculiarities cannot be pointed out. A description which covers several pages may prove tiresome reading to the busy practitioner; but when he becomes the bacteriologist, and by comparison must identify the species which he has captured by reference to that same long description, it will prove too short rather than over long, for a whole volume upon a new organism is worth more than such descriptions of the earlier writers as "short rods having a springing movement," or "round dots enclosed in epithelial cells."

As has been intimated, most of the bacteriological studies of the eye have been the outcome of researches in special fields. So far as we know, there has never been an attempt to bring together a list of all the organisms which have been found in the eye, and the number of investigators who have studied the conjunctiva for the purpose of determining how great a variety of bacteria it would yield has been very small.

The editors of this work conceived that one source of the bacteriological errors made by ophthalmologists depended upon the insufficient data with which they were furnished, and deemed it advisable to enter in their System this paper, which should comprise as complete a catalogue as possible of all the bacteria which have been found upon the conjunctiva and in the lacrymal apparatus, as well as an experimental research for the possible discovery of new ones.

For this purpose the following cases from the Eye Clinic of the University of Pennsylvania and of the Wills Eye Hospital were kindly placed at our disposal :

Normal conjunctivæ . . . . .	13
Acute catarrhal conjunctivitis . . . . .	3
Follicular conjunctivitis . . . . .	1
Granular conjunctivitis . . . . .	5
Phlyctenular conjunctivitis . . . . .	1
Chronic conjunctivitis with blennorrhœa of sac . . . . .	3
Chronic conjunctivitis of socket . . . . .	1
Scrofulous keratitis . . . . .	1
Iritis . . . . .	2
Specific iritis . . . . .	1
Lacrymal obstruction . . . . .	26
Dacryocystitis . . . . .	1
Panophthalmitis . . . . .	1
Ophthalmia neonatorum . . . . .	1
Traumatic cataract . . . . .	1
Chronic ectropion . . . . .	1

The result of the examination of these cases seems to have proved the habitual presence of micro-organisms upon the conjunctivæ, and to have shown that the species most commonly found are those most frequent in the air and in the dust. Thus, the eye in which the greatest number and variety of microbes occurred was in a case of chronic ectropion. On the other hand, Bernheim, of Professor Haab's clinic in Zurich, in an elaborate treatise, has convincingly shown that the lacrymal secretion possesses a feebly antiseptic power.

For the convenience of the reader, we have thought it advisable to place the results of our observations, together with those of our predecessors, in as complete an alphabetical catalogue of the numerous micro-organisms that have been described as occurring upon the conjunctiva and in the lacrymal sac as is possible, sparing no pains in making the descriptions clear, and trusting to the reader's patience to see him through the following pages.

*Bacillus Cœrulefaciens* (n. sp., McFarland).—This bacillus was met with once in the conjunctival secretion of a case of granular conjunctivitis.

It is a minute bacillus, measuring from about 1.50 to 1.75  $\mu$  in length, and, being very slender, often curved, so that there is some resemblance between it and the tubercle-bacillus. It was never observed to form filaments or chains, the individuals being constantly isolated and having rounded ends.

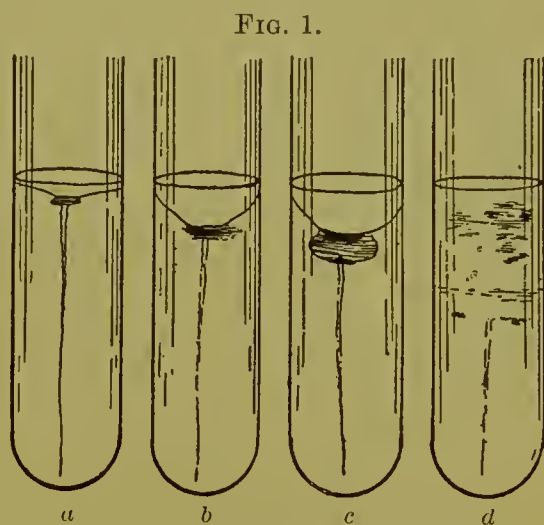
When examined in the hanging drop, the individuals are found to be actively motile. No spores can be detected.

The bacillus colors quite well with the ordinary dyes, and stains well by Gram's method.

When cultivated upon gelatin plates the colonies appear in from twenty-four to forty-eight hours as small, circumscribed, round, slightly granular points, which increase but little in size in the next twenty-four hours,

which have a yellowish color, and which gradually sink below the surface, possibly because of the evaporation of the slowly liquefied gelatin.

At different times cultures made by puncturing the gelatin behaved differently. One series of tubes showed no liquefaction, but a yellowish surface growth and a moderate growth in the puncture, from the upper part of which a few filaments were seen radiating into the normal gelatin immediately below the surface growth. A second series, made some time later, produced a small area of liquefaction below the surface growth. A third series, made in gelatin to which glucose was added, did not liquefy, though the growth attained considerable size and was whiter than on ordinary gelatin. From this it would seem that this organism does liquefy at times, while at other times it does not. The liquefaction must always be slow. No gas-bubbles are observed.



Cultures of *bacillus coerulefaciens* in gelatin.  
—*a*, 1 week, *b*, 2 weeks, *c*, 3 weeks, and *d*, 4 weeks old.

Linear cultures upon agar-agar are devoid of any characteristic peculiarities. The growth appears simply as a delicate, slightly yellowish, translucent band.

The growth on potato is beautiful and characteristic. In the course of twenty-four hours a yellow band of a lemon hue, smooth and shining, considerably elevated above the potato, occurs along the line of inoculation. This increases in size for the next twenty-four hours, and at the temperature of the room a change takes place in the potato, which begins to take on a bluish color in immediate contact with the growth. On the third day the potato, for a considerable area surrounding the growth, becomes of a brilliant blue, which deepens in intensity by the fourth day, and by mixing its color with the yellow of the growth causes the latter to appear green. On the third day the appearance of the bright yellow growth on the blue potato is very pretty.

When the cultivation is conducted in the thermostat, the growth is yellow, but no change occurs in the potato. After from seven to nine days the blue color fades and leaves a dirty-greenish growth upon a lead-colored potato. The more frequently the bacillus is grown upon potato the more intense is the blue color.

When cultivated in liquid media, such as bouillon and peptone solution, no other change than a diffuse cloudiness can be observed.

There occurs a progressive and intense alkali production, which causes the blue color of the litmus milk to deepen. In the second week a scarlet ring begins to form about the top.

In some respects, as, for instance, the formation of a scarlet color upon the surface of the litmus milk, this bacillus resembles the bacillus lactis erythrogenes of Hüppe, of which it may possibly be a variety. The differences are, however, so marked that we feel justified in describing it as a new species. The bacillus lactis erythrogenes is non-motile; the bacillus cœrulefaciens is motile, and actively so. The former has for its characteristic growth upon potato the formation of a grayish-white band upon a darkly discolored potato which subsequently becomes reddish, while the yellow and blue of the latter never fail. The growth also differs in gelatin and on agar-agar.

*Capsule Bacillus of Loeb.*—This was obtained from a case of keratomalacia infantum by inoculating media with a little of the softened exudate of the cornea. It resembles the bacillus capsulatus of Pfeiffer, but is said to be somewhat larger and thicker than the latter. In the blood of mice, however, both bacilli vary considerably in size, and, according to Loeb, it is not possible to determine with certainty that one bacillus is, on the average, larger than the other.

In staining reactions, also, no difference is observed; both bacilli stain with the usual aniline colors, and under certain circumstances the centre of the rods is less deeply stained than are the extremities.

It is an aerobic and facultative anaerobic, non-liquefying, non-motile bacillus, and grows in the usual culture media at the room temperature. In its growth in culture media it closely resembles the bacillus capsulatus of Pfeiffer.

It is pathogenic for mice and for guinea-pigs, but not for rabbits and for pigeons; Pfeiffer's bacillus is pathogenic for these animals.

*Bacillus of Colomiatti.*—This organism was obtained from xerotic masses obtained from the eye of a child, and in cases of conjunctivitis from the lacrymal fluid. The morphology of the organism is similar to that of the bacillus of mouse septicæmia, and its size is almost the same. Generally the bacilli are associated in irregular groups.

The organism is aerobic, does not liquefy gelatin, forms small spherical spores, generally situated at the ends of the rods, and is not possessed of motility. It requires a temperature of 34° to 39° C. for its development, and appears on agar-agar as a thin, colorless film with a highly refracting, lustrous character. On blood-serum a long, dull gray band, about two millimetres in breadth, with the same lustre, occurs. It does not develop upon potato or in gelatin.

We succeeded in cultivating an organism similar to this from a normal conjunctiva, but the description given is too meagre to allow us to identify it.

*Bacillus Circumscriptus (McF.).*—This short, oval bacillus, measuring from 1  $\mu$  to 1.5  $\mu$  in length and from .5  $\mu$  to .75  $\mu$  in breadth, with rounded ends, seldom forming chains of as many as ten individuals, and to all appearances without spores, was found but once. It was a delicate grower, and did not pass through many generations before dying out.

It stains well with the aniline dyes and excellently by Gram's method, which caused it to appear a little longer and more slender.

Upon gelatin plates the colonies appear in twenty-four hours. After forty-eight hours they are seen as slightly granular, orange-yellow, sharply circumscribed, slightly elevated masses, which are soon surrounded by a slight depression, which becomes larger as the gelatin slowly liquefies and evaporates. The colonies always remain small.

In gelatin punctures the growth does not attain any characters until several days have passed. About the fourth day a dimple is visible upon the surface, at the bottom of which a yellow speck is observed. This increases in size and becomes a sort of surface growth which is at the bottom of a cup from which the liquefied gelatin evaporates. In about two weeks the liquefaction proceeds more rapidly than the evaporation and causes the yellow growth to float in the liquid. In three weeks the liquefaction, which remains cup-like, reaches the sides of the tube, but spreads downward slowly, so that the liquefaction is not complete until six or eight weeks, after which the liquefied gelatin is flocculent.

The growth on agar-agar is circumscribed, forming a rather narrow band along the line of inoculation. It is of an orange-yellow color, transparent, and spreading at the sides by a series of rounded processes somewhat resembling the dulled teeth of a saw. It never spreads over much surface, and avoids the expressed water. When touched with the platinum wire it is quite friable, and the broken masses of it can with ease be slid about on the surface of the agar. The agar does not become colored.

Although several attempts were made to grow the bacillus on potato, it was never accomplished, either at the room temperature or at the temperature of the body.

In litmus milk there seems to be a slight increase of alkalinity and subsequent digestion.

The growth in bouillon is rapid, and causes a diffuse cloudiness with a flocculo-gelatinous precipitation.

This bacillus has not a few features in common with the *bacillus fulvus* of Zimmermann, but differs in its growth in gelatin and on agar, and markedly in not growing on potato, and in producing alkalinity instead of acidity in litmus milk.

*Bacillus Coli Communis*.—This bacillus was for a long time considered to be a mere saprophyte, but its presence is now nearly universally admitted in many inflammatory lesions, sometimes accompanied by other pathogenic germs, very often alone. Its importance in diseases of the conjunctival tract is shown by the observation of Randolph,<sup>1</sup> who reports the presence of a germ identical with the bacillus coli communis in the pus from a case of panophthalmitis traumatica. It was the only organism found, and inoculation experiments were successful.

---

<sup>1</sup> American Journal of the Medical Sciences, 1893, p. 440.

The microbe is a bacillus, aerobic and facultative anaerobic, motile, but not actively so; it does not liquefy gelatin, and does not produce spores. This motility is seen, by appropriate staining, to be due to the action of flagella, generally from three to six in number.

It stains with the aniline dyes, Löffler's methylene-blue or Ziehl's carbol-fuchsin being the most successful. Gram's method gives negative results. A colored cover-glass preparation, microscopically, shows small bacilli, 2 to 3  $\mu$  in length by 0.4 to 0.6  $\mu$  in thickness, isolated or in pairs. A certain pleomorphism seems to exist, for associated with these we find longer bacilli, measuring 5  $\mu$  and even more in length, and often small cocci forms about 0.5  $\mu$  in diameter. Irregular forms of involution and degenerative forms are frequently met with.

On plates of ten-per-cent. gelatin, small, pale, straw-colored, homogeneous or finely granular colonies soon make their appearance. They become darker in the centre, and are then surrounded by more transparent zones. Generally they are round, but they may be irregular in shape. Upon the surface they are larger, often spreading to three or four centimetres in diameter. These have an opaque centre surrounded by a semi-transparent zone with undulating margins, and are often irregular in shape and marked with concentric lines. In stick cultures in the same medium a similar growth covers the surface of the gelatin, but more luxuriant in development, and the growth along the line of inoculation is composed of closely packed colonies, which are white by reflected and yellowish brown by transmitted light. Crystals of ammonio-magnesian phosphate very often appear as moss-like outgrowths from along the puncture. The gelatin is never liquefied.

A stroke culture on agar and on blood-serum develops as a luxuriant cream-white, moist band. On potato the growth is a moist, spreading, dirty yellow or brownish layer, or may have a greenish tinge,—“pea soup.”

Bouillon becomes rapidly clouded, and a thin skin—mycoderm—often forms on the surface. Milk to which litmus has been added becomes acid (lactic acid), is soon coagulated, and afterwards gradually loses its pink color.

Gas-bubbles occur in almost all the cultures, but this is more marked in media to which glucose has been added, and in the absence of oxygen.

The bacillus coli communis possesses a great resistance to heat, development taking place at a temperature of 46° C. The thermal death-point is at 60° C. after ten minutes' exposure.

Recent investigators have described so many varieties of this organism that it is doubtful if it can be regarded as a distinct species. Many of what have been regarded as the essential characteristics of the bacillus, such as its growth on potato and in milk, and its motility, vary so greatly that it seems as if we had to do with distinct microbes, and as if the name bacillus coli communis should be applied, not to any one organism, but to a whole genus. However this may be, its pathogeny is clearly established,



both by its presence in diseased states and by inoculation experiments upon the lower animals.

*Bacillus Diphtherie* (Klebs-Löffler).—This organism is by no means rare in the eye, being found in the course of diphtheria of the nasal passages as well as pseudo-membranous inflammations of the conjunctiva. The cultivation of the bacillus presents little difficulty, as it grows luxuriantly upon most culture media. The colonies are generally ready for study on the following day. Löffler recommends the use of a mixture of one part of one-per-cent. glucose bouillon and three parts of blood-serum. The mixture is dispensed in tubes and sterilized and coagulated like blood-serum. The advantage of the use of this mixture is that the bacillus diphtheriæ grows more rapidly upon it than do the other organisms with which it may be mixed, and on this account the isolation of the diphtheria bacillus may be simplified, for the first colonies to appear are those of that organism. To secure it, a small fragment of the pseudo-membrane should be detached by means of a sterile platinum wire and smeared over the surface of a tube of sterilized and obliquely gelatinized Löffler's mixture. As too many of the bacilli are planted without sterilizing, it is well to smear the surface of another tube, then of a third. In diphtheritic membranes the bacillus is generally present in large numbers in the upper layers, but usually mixed with streptococci. Upon the surface of a tube prepared in the described manner many colonies of these two organisms will appear in twenty-four hours at the temperature of 37° C., and transplantations from the colonies may easily be made to new tubes, so that pure cultures may be obtained.

Instead of smearing the surface of the Löffler's blood-serum mixture, as described, the material secured by the wire may be mixed with melted gelatin or agar-agar and poured into Petri dishes, or rolled in the tube according to the method of Esmarch, and the colonies studied with the microscope before being transplanted. When studied in this way upon gelatin plates, at the temperature of 24° C., the colonies appear as small, round, white growths, which do not exceed a moderate limit in size and never liquefy the gelatin. Under the microscope, by transmitted light, they appear of a yellowish-brown color, thick, granular, and with irregular borders.

If the colonies are grown upon glycerin agar-agar kept at the temperature of the body, in from twenty-four to forty-eight hours they appear as flat masses of the size of millet-seeds, with even borders, are grayish-white in color, and to the naked eye present a slight concentric arrangement. Under the microscope they are granular, and resemble colonies of bacillus megatherium.

When the colonies are developed upon the Löffler blood-serum-peptone-glucose-bouillon mixture, smeared as described above, they are more luxuriant in development and of greater size than on either gelatin or agar-agar, appearing as white or cream-colored patches, more opaque in the centre than at the periphery, which is irregular. Interspersed among these whitish

colonies of the diphtheria bacillus will be a few yellowish or orange colonies of small size. The surface of the colony is moist when young, but later becomes dry.

Gelatin puncture cultures are interesting. No liquefaction is produced, the bacilli growing in the track of the needle as small, white, round masses, without much tendency to spread.

Stroke cultures upon agar-agar and glycerin agar-agar do not develop so well as upon blood-serum, but appear in about forty-eight hours as isolated grayish-white circular patches averaging the size of a pin's head and showing a marked disposition to remain isolated, though sometimes becoming confluent.

Upon blood-serum the growth of the organism produces a thick, whitish, opaque layer. In bouillon at the temperature of the body, small white cohering masses resembling grains of sand are found. These sink to the bottom or attach themselves to the walls of the tube. The liquid itself remains clear, for which reason the appearance may be regarded as characteristic. The reaction of the bouillon is said to be changed first to acid, then later to alkaline. The organism grows astonishingly well in milk, which may be a frequent means of infection.

On potato, at the temperature of 35° to 37° C., several days pass in which no growth can be observed; but later a thin dry glaze occurs along the line of inoculation, where the growth is developing with slowness.

The morphology of the bacillus is peculiar and almost characteristic. When examined in the hanging drop the organisms are found to be straight or slightly curved rods, about 2 to 3  $\mu$  in length and .5 to .8  $\mu$  in diameter. Many misshapen individuals are found which may be involution forms, and which are quite characteristic. Some of these are club-shaped when one end is swollen, others are dumb-bell-shaped when both ends are swollen. Sometimes the organism appears to be made up of segments, of which the terminal are sometimes more highly refracting than the central. The bacilli are rounded at the ends. They are not motile, do not form spores, never grow into filaments.<sup>1</sup>

The pathogeny of the organism is peculiar and interesting, as it may or may not be virulent, and as a non-virulent organism sometimes plays the rôle of a saprophyte. It seems possible, however, for these non-virulent individuals to develop virulence under certain conditions which are as yet unknown to us, and on this account the organism becomes highly dangerous as a saprophyte, and most strenuous disinfection should be practised in every case to prevent the spread of the organisms by clothing or other fomites.

---

<sup>1</sup> They present few staining peculiarities, being, perhaps, a little reluctant to take the dyes ordinarily used, but staining well by Gram's method and with the Löffler alkaline methylene-blue solution. Welch and Abbott highly recommend the use of Weigert's fibrin method for demonstrating them in sections, using carmine and picric acid to bring out the tissue.

When virulent, a culture which is introduced beneath the skin of a guinea-pig or a kitten, these being among the most susceptible animals, produces death in from one to five days. At the point of inoculation a grayish-white pseudo-membranous formation occurs. Soon constitutional disturbances occur, and hemorrhages take place into the deeper tissues,—a hemorrhagic œdema of the subcutaneous cellular tissue which not infrequently causes pleural accumulations. In the trachoma of chickens, pigeons, and rabbits, the bacilli, when introduced, produce a pseudo-membrane. Guinea-pigs die in twenty-four to forty-eight hours; rabbits live longer, sometimes even several weeks. It sometimes happens, when animals injected continue to live for six or seven days, that diphtheritic palsy comes on, affecting first the posterior, then the anterior limbs, finally producing such complete palsy and loss of co-ordination that the animals die from the result of the symptom alone. Mice and rats are refractory. Birds, such as finches, sparrows, pigeons, chickens, also rabbits and guinea-pigs, are very susceptible.

Investigated by Löffler, Roux, and Yersin, the poison of diphtheria is found to be a toxalbumin, easily soluble in water.

It is with some difficulty that the bacillus of diphtheria is separated from a closely appearing form of harmless nature described as the *pseudo-diphtheria bacillus*. The colonies and microscopic appearances are identical with diphtheria, but it differs from it in (Roux and Yersin) that the bacillus pseudo-diphtheriticus is often shorter in colonies grown upon blood-serum; the cultures in bouillon are more abundant. The changes of reaction occur more quickly in pseudo-diphtheriticus than in diphtheriticus. Inoculation of this bacillus into animals has never caused death.

It is very probable that the pseudo-diphtheriticus is only an attenuated or non-virulent diphtheriticus.

Faye<sup>1</sup> asserts that all cases of pseudo-membranous conjunctivitis are not true diphtheria. Securing the assistance of Dr. Auché to aid in the bacteriological research, cultures were made from fragments of pseudo-membranes from an acute case of pseudo-membranous conjunctivitis occurring in a child of fifteen months; but from these no other organisms grew than the streptococcus pyogenes and the staphylococcus pyogenes albus. None of the Klebs-Löffler bacilli were found.

Dr. E. Kain<sup>2</sup> found in a case of membranous or croupous conjunctivitis only one kind of bacillus which did not grow on gelatin at 34° C., and which on agar and serum made a homogeneous appearance which could be regarded as a pure culture.

They are small double rods 0.6 to 1.0  $\mu$  long and of scarcely measurable thickness, and did not seem to possess any motility. They tended to mass themselves together.

<sup>1</sup> Archives d'Ophthalmologie, 1891, ii. p. 52.

<sup>2</sup> Zur Actiologie der Conjunctivitis Crouposa, Wiener Klin. Wochenschrift, 1892, No. 10, 153.

They take the aniline colors well, showing a slight constriction in the middle, which, however, can also be seen in the uncolored condition, and gives the bacillus the appearance of an 8.

In the membrane the rods lie together in thick round clumps, isolated individuals being few. In the large masses of multi-involuted cells contained in the membrane some few can be found which contain three or four of the bacilli. They refuse to take the stain by Gram's method. The appearance of the colonies on agar-agar is characteristic. After thirty-six to forty-eight hours little whitish transparent points occur on the surface, which increase to one millimetre, but not beyond this size.

Under the microscope they appear light brownish and finely granular, so that they may be described as "broken-glass" colonies. The larger colonies show a dark centre, the border being finely "gezackt und verwischt." The deep colonies appear as black, angular granules.

On gelatin plates they occur as small, milk-white, round colonies, more convex than on agar, and easily removable.

*Bacillus of Fick*.<sup>1</sup>—This bacillus, which measures about 1.4 to 1.7  $\mu$  in length and 0.8 to 1.0  $\mu$  in breadth, is so peculiar in its appearance as to make the observer consider before classifying it as either a bacillus or a coccus. The individuals are so short that, especially when united in pairs, they bear great resemblance to the diplococci. Each individual, or each pair when they are so arranged, is surrounded by a transparent capsule or halo.

They stain by ordinary methods, and also retain the color well by Gram's method.

Gelatin punctures begin to develop in the first twenty-four hours, and in four days form a typical nail-shaped growth, the head of the nail having a slightly yellowish color. No liquefaction of the gelatin takes place.

The growths on agar-agar much resemble the gelatin cultures. The growth takes place at the temperature of the room as well as in the thermostat.

Fick was unable to secure pure cultures on blood-serum.

The organism almost invariably refused to grow upon potato. Only twice could small, wrinkled, yellowish colonies of an elliptical shape, and measuring 1.7  $\mu$  long and 1.0 to 1.2  $\mu$  thick, be observed.

When inoculated into the corneal tissues the organism produced a distinct keratitis, and, sometimes, caused a perforating ulcer, which required about four weeks to penetrate the corneal tissues.

(There seems to be very little difference between this bacillus of Fick and the *bacillus lanceolatus pneumoniæ*.)

*Bacillus Fluorescens Liquefaciens*.—This organism was found by Fick in only one of the eighty-four cases which he studied.

It is a bacillus of moderate size, which measures from 0.8 to 2.5  $\mu$  in length and from 0.4 to 0.5  $\mu$  in breadth. Many of the organisms have a

<sup>1</sup> Ueber Microorganismen im Conjunctivalsack, 1887.

quadrilateral form with rounded corners. Others have round ends. They are frequently joined in pairs which exhibit a constriction at the junction. No spores have been observed in this bacillus.

Upon gelatin plates whitish colonies develop upon the surface, and may attain a diameter of three millimetres. A ring of liquefied gelatin forms around each. When examined under a low power of the microscope, they are seen to have a sharp contour and an irregularly circular outline, and to consist of a granular centre, which is surrounded by a finely granular marginal zone of a yellow color, becoming more transparent and grayish white towards the edge. The gelatin gradually acquires a greenish tint.

In gelatin puncture cultures a rather scant whitish growth occurs along the path of the needle, terminating above in a small funnel of liquefied gelatin surmounted by an air-bubble. Fick's cultures first attained considerable size as a "nail colony" before the liquefaction began. As the liquefaction begins, the green color which characterizes the species is developed. When once begun, the liquefaction advances with considerable rapidity, and is accompanied throughout by the color-production. As the liquefaction reaches the sides of the tubes and extends downward, a whitish powdery precipitate is seen to accumulate at the bottom. The gelatin cultures give off a slight unpleasant odor.

Upon the surface of agar-agar a grayish or yellowish-green pellicle is formed. It is generally about the second day that the agar-agar in the immediate neighborhood of the growth begins to turn green, but is sometimes later. In about ten days the whole of the agar-agar becomes colored a bright green.

Potato cultures sometimes show a brownish growth, devoid of characteristics which aid in diagnosis; sometimes potato cultures fail altogether.

Fick experimented upon three rabbits in order to determine whether this organism was capable of producing pathological changes in the eye or not, and was obliged to conclude that it was non-pathogenic.

When examined in the hanging drop, the individuals, which are frequently joined in pairs, as has been mentioned of stained specimens, are found to be actively motile.

The bacillus stains well, but when treated by Gram's method it always gives up the color.

The organism is chiefly characterized by the fluorescent pigment which it produces both on gelatin and on agar-agar.

*Bacillus Hirsutus* (McFarland).—This bacillus was obtained from the normal conjunctiva. It is a large bacillus,  $1.75 \mu$  by  $3.5 \mu$ , with ends which are rounded when free, but squared when filaments are formed and the individuals are joined together. Long threads of twenty or even more individuals are very common. The first impression obtained when these organisms are observed is that they are without locomotive power; but if a single individual be observed for a short time it may be observed to start

off abruptly and swim quietly but swiftly away. Chains of two and three—even four—likewise possess this motility.

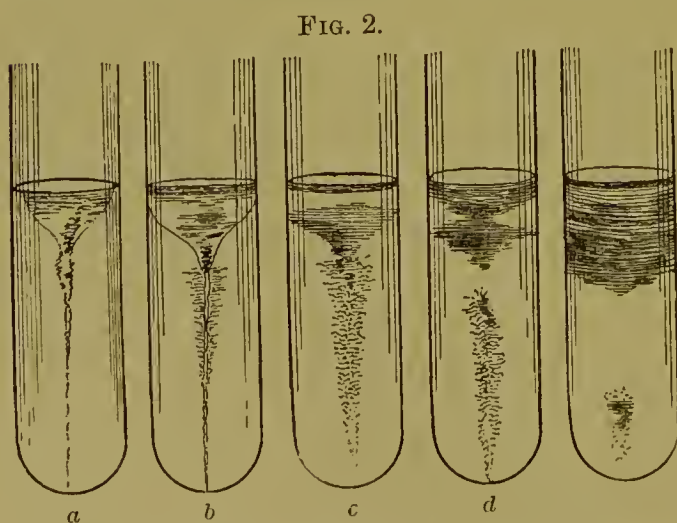
Fresh cultures in gelatin and agar-agar are generally composed of long threads, and are very constantly without spores. Old cultures, however, particularly agar-agar cultures, present large numbers of large oval spores situated in the centre of the bacillus, but not disturbing its contour, and often lying free.

When cultivated, the bacillus grows well, is a fine organism for experimentation because of its many pronounced characteristics, and bears a distinct resemblance to anthrax.

On gelatin plates the colonies appear in eighteen hours as colorless spherical bodies of minute size, having already a laminated appearance, as if composed of coils of bacillary chains, and showing projecting centrifugally arranged threads on all sides. In twenty-four hours the colonies have doubled in size and are decidedly hairy or bristling in appearance and irregular in shape. From the superficial colonies long, irregular processes extend over the surface of the gelatin, turning and twisting upon themselves. These processes are smooth at the edges, and on careful examination can be seen to consist of parallel threads of bacilli. In about thirty-six hours liquefaction of the gelatin occurs, and the colony appears as a floating island, with innumerable radiating, perfectly straight hairs or threads by which it is moored to the solid gelatin. These radiating filaments extend eccentrically for considerable distances upon the normal gelatin, and suggest the sun with radiations of light in all directions. After forty-eight hours liquefaction is rapid and the colony becomes broken up. At the time when the long radiations occur, beautiful adhesion-preparations can be made.

The growth in gelatin puncture cultures is very characteristic. In six hours, in an ordinary room, the growth can be observed upon the surface

of the gelatin as a delicate, colorless film. The gelatin begins to liquefy below this with great rapidity, so that a funnel is formed, at the apex of which the growth in the puncture shows radiating, bristling, or spiny projections, some of which are short, others reaching to the sides of the tube. This occurs along the whole puncture. In three days the apex of the funnel has reached half-way to the



Cultures of *Bacillus hirsutus* in gelatin.—*a*, 24 hours, *b*, 48 hours, *c*, 3 days, *d*, 6 days, *e*, 2 weeks old.

bottom of the tube and extended to its sides, and at this time a distinct, whitish, irregular mycoderma has formed upon the surface. Flocculi float

in the liquid, and later precipitate at the apex of the funnel. The superficial mycodermia seems to contract and detach itself from the sides of the tube, so that in forty-eight hours after its formation it sinks entire and is rapidly replaced by a second, which likewise sinks, to be replaced by a third. There do not seem to be more than three or four mycodermiata naturally formed, but by agitating the tube, and thus hastening their separation, a much larger number can be formed. The gelatin is generally all liquefied in less than ten days.

When the projecting spines which develop along the puncture are subjected to a microscopic examination, they appear feathery, each large projection having innumerable smaller parallel hairy processes extending from it.

Upon the surface of agar-agar the growth is rapid at the temperature of the room, more rapid at the temperature of the body, and is characteristic. The growth occurs along the whole length of the stroke, and spreads laterally for some distance with considerable rapidity. The result of this is a long longitudinal wrinkle crossed by innumerable transverse ones. The growth is whitish translucent in character, becoming slightly tinged with yellowish brown when old. From the margins little tongue-like projections extend upon the agar, giving the impression of a halo to the naked eye, but showing on close inspection. The whole growth makes a flat, wrinkled band, which extends at the base, which is quite brittle and easily broken up with the platinum wire, and which detaches everywhere if the tube be filled with water. When the cultures are old the agar-agar becomes yellowish brown.

The bacillus grows well on potato, a broad, elevated, colorless band forming in forty-eight hours. This growth has a dull appearance to the naked eye, and when examined by a lens has a highly characteristic villous appearance. The whole surface is covered by projecting, smooth, dull villi. The edges of the growth exhibit a more massive development of these villi than the centre, and appear to the naked eye as whitish dots, which when magnified become warty masses. Later, when the culture becomes partly dried, these villosities become ivory-like, and make the culture appear as if sprinkled with white powder.

Bouillon rapidly becomes turbid, and a mycodermia forms upon the surface. As with melted gelatin, this soon sinks and is replaced by a new one.

Litmus milk is completely decolorized in two to four days. No coagulation until after the third day. After coagulation the casein is digested with considerable rapidity, and a clear fluid remains which has an alkaline reaction.

Careful study, made by adding sulphuric acid and potassium nitrite to cultures made in Denham's solution, shows a faint pink, as if a small amount of indol was produced by the organism in its growth.

In order to confirm the test for acidity made by the litmus milk, cultures were made in peptone rosolic acid solution, but without any change of color, although kept for weeks. The growth in the peptone and peptone rosolic acid solutions resembled that in bouillon.

Blood-serum was rapidly liquefied by the growth of the bacillus, no particular features being observable.

The growth in gelatin containing glucose was the same as that in plain gelatin, but rather more luxuriant.

Attempts were made to produce pathogenesis by hypodermic injections into mice and rabbits, but the animals remained healthy, so that the organism seems to be non-pathogenic.

The bacillus stains readily by most aniline dyes, and also very well by Gram's method.

*Bacillus Influenzæ*.—The microbe that is the causative factor in epidemic influenza is of late discovery. Pfeiffer, in January, 1892, first described the morphology and biology of a bacillus which he obtained in enormous numbers from the sputa of every case of influenza, and never from that of many cases of ordinary coryza that he examined. At the same time, Canon, of Berlin, announced the presence of the same organism in the blood of patients. In the opinion of these investigators, and of Kitasato, based on examination of cases and on inoculation experiments, this bacillus is undoubtedly the cause of influenza.

The question of its presence in the conjunctiva and lacrymal tract is yet not proved, although there is great reason to believe that on examination it will be found in these localities. Weichselbaum holds that all the neighboring cavities of the nose, including the nasal duct, are infected in pneumonia, in typhoid fever, and in influenza. Berger points out the intense conjunctivitis with which the onset of the "grippe" is marked, and regards it as originating in the inflammation of the nasal and bronchial passages. In view of the extreme probability of the correctness of these opinions, it was deemed advisable to include a description of the bacillus *influenzæ*.

It was obtained by Pfeiffer from uncomplicated cases in nearly pure culture. It is a bacillus with rounded ends, aerobic, non-motile, and very small, being  $0.5 \mu$  in length and about  $0.2 \mu$  in thickness. Generally solitary, or in chains of three or four elements, it sometimes occurs in small masses containing as many as fifty bacilli. (Canon.) In old cultures of three or four days' growth there occur long, thread-like, abnormal forms of beginning involution. No spores have been observed.

During the onset of the disease the far greater number of bacilli occur free in the secretions, but subsequently to the acute stages they are nearly all found in the interior of the corpuscular elements.

With basic aniline dyes it stains with difficulty, but is best colored by the use of Ziehl's carbol fuchsin or Löffler's methylene-blue solution, with the additional aid of heat. The ends stain much more deeply and give the microbe an appearance of a diplococcus. Pfeiffer thinks that many of the former observers have made this mistake. The diplococcus described by Babes may have been the bacillus under consideration. In the blood, Canon made use of Czenzynke's method. The blood was dried on the cover-glass, after having been fixed, was placed for five minutes in absolute alcohol, and



then in the stain (sol. sat. methylene-blue aq., 40; sol. cosin alcohol (70 per cent.) 0.5 per cent., 20; aq. destil., 40) for from three to six hours at a temperature of 37° C. The cover-glass was then washed thoroughly with water and mounted in Canada balsam. Seen under the microscope, the erythrocytes are red, stained by the cosin; the leucocytes and bacilli are blue, stained by the methylene dye.

Sections of tissue are stained by using Ziehl's solution and very watchfully decolorizing in absolute alcohol that has been slightly acidified by acetic acid. The object is to remove the section from the alcohol the moment at which the tissue itself is decolorized and the microbes still retain the stain, on account of their greater imperviousness. The bacilli do not stain by Gram's method.

The bacillus taken from a nearly pure culture, as found in the nasal or the bronchial secretion, develops but slightly on the ordinary culture media. Below 28° C. and above 42° C. it ceases to grow, and its thermal death-point is at 60° C. Five minutes at this temperature suffice to kill it. On solid gelatin, therefore, no growth can be obtained.

In bouillon, at the end of twenty-four hours there occur a few small white points, which soon sink down and form a slight flocculent deposit, leaving the liquid clear. Pfeiffer was unable to obtain any growth. On glycerin agar, at the end of twenty-four hours' exposure to a temperature of 37° C., small, pin-point, transparent, water-like drops make their appearance, and often can be recognized only by the aid of a lens. They do not coalesce, and Kitasato points out this fact as a means of differentiation for this microbe.

A similar growth occurs on 1.6 per cent. agar-agar. (Pfeiffer.)

Pfeiffer found that transplanting gave negative results on these media, and even on gelatinized human and animal blood-serum and on Löffler's mixture of blood-serum and agar. He noticed that when a small amount of blood was smeared over the surface of the media, a transplanted culture would develop most rapidly and luxuriantly into small colonies of glass-like transparency and with but little tendency to coalesce. These did not grow in the drops of blood, but around them and at a slight distance from the periphery. By a series of experiments he proved that hæmoglobin was the essential factor in this increased vegetative power. In the same manner he succeeded in obtaining successive generations upon agar and blood-serum and in bouillon.

The bacillus of influenza is easily destroyed by dryness and by light and heat. An exposure in a dry atmosphere at 37° C. for one-half to one hour will cause its death.

*Bacillus of Kartulis*.<sup>1</sup>—*Bacillus of Egyptian Catarrh*.—Koeh found a large number of diseased eyes in the Greek Hospital in Egypt to contain gonococci of Neisser. Kartulis confirmed this in hundreds of experiments.

<sup>1</sup> Centralb. f. Bakt. u. Parasitenk., 1887, i. 289.

In one instance the pus from a case of blepharorrhœa conjunctivitis was inoculated by means of a soft catheter into the urethra of a healthy man and produced typical gonorrhœa.

Koch also discovered in the pus-cells small bacilli like those of mouse septicæmia. In fresh cases of conjunctivitis the bacilli are rich in the pus-cells. They sometimes occur free between the cells, but never occupy the nucleus.

Kartulis could never cultivate the bacillus on peptone gelatin. At the temperature of 28° C. to 36° C. he succeeded in securing characteristic cultures. On agar-agar the same occurred of a microscopically visible size in thirty to forty hours. At first along the stroke there are fine grayish-white points, forming a patch. These gradually unite to form a narrow streak, which elevates itself above the culture medium very distinctly. The pure culture is now shining and dark-colored, of a fatty appearance. The borders are irregularly wave-like and sometimes notched. Gelatin is not liquefied. The patch remains for a considerable time in this form, then gradually dries, and looks like a fish-bone.

The young bacilli appear a little plumper in the cultures than in the pus-cells. On old cultures they are much like those of mouse septicæmia, being so thin and delicate as to be almost invisible. No spores have been observed. The pure cultures, as well as pus-cells containing the bacilli, give rise to but little disturbance in animals, but produce positive cases of the disease in men.

*Diplococcus Lanceolatus Pneumoniæ*, Talamon (*Micrococcus Pasteuri*, Sternberg; *Diplococcus Pneumoniæ*, Weichselbaum).—This micro-organism was first obtained by Pasteur and by Sternberg in 1880, from human saliva; and the further investigations of Talamon, Fraenkel, and Weichselbaum have given us evidence that it is the causative agent concerned in croupous pneumonia. Since then it has been found in other inflammatory exudates,—in meningitis, endocarditis, pericarditis, pleuritis, peritonitis, etc.,—and in pure cultures in acute abscesses. It is, therefore, to be classed among the pyogenic germs. The researches of Gasperini, as reported at the Eleventh International Congress in Rome, show it to be one of the most frequent microbes that inhabit the conjunctival sac.

The form of this microbe is that of a very short bacillus,—an oval coccus, as it is commonly called ( $1.5-0.5 \mu$  by  $1-0.5 \mu$ ),—generally occurring in pairs. In blood and exudates it has a lanceolate shape (hence the name),—that of a grain of wheat or of a candle-flame, as it has been variously described, with the pointed ends turned outward. Often it is met with in chains of from three to ten elements, and often singly. It is surrounded by a gelatinous capsule, but this is very rarely present in cultures on artificial media.

The bacillus takes on the aniline stains readily, and is not decolorized by Gram's method, which distinguishes it from Friedländer's bacillus. The capsule can be colored by a one-minute immersion in a one-per-cent.

solution of acetic acid, followed by aniline gentian violet; or (Ribbert) by a rapid treatment with a saturated solution of dahilia in the following: aq. dest., 100; alcohol., 50; acid. acetic., 12.5. Sections of tissue can be left in the stain longer (ten to twenty hours), and partially decolorized by one-per-cent. acetic acid.

It does not develop in artificial media below 22° C. or above 40°–42° C., and has a thermal death-point of 52° C. (ten minutes).

On plates of fifteen-per-cent. gelatin, at 24° C., there grow at the end of one day small, round, granular, grayish-white colonies, which slightly spread on reaching the surface. They never grow very luxuriantly. A slight line of white colonies appears along the path of the needle in tube cultures.

On agar plates, at 36° C.,—the optimum temperature,—there soon appear little, watery colonies, like drops of dew, which, microscopically, are seen to have a finely granular centre surrounded by a more transparent granular zone. On blood-serum and on agar the growth is a thin, semi-transparent, “jelly-like” band. At most there is only a slight cloudiness, with a fine deposit, in bouillon. The development is greater in milk; the casein is coagulated. No growth occurs on potato.

Inoculation of virulent cultures into the lower animals, especially mice and rabbits, causes death from an acute septicæmia. Its virulence, however, and also its vitality, are very soon lost by cultivation.

*Bacillus Lepræ* (Hansen and Neisser) is a still less frequent resident of the conjunctiva, occurring only in cases of lepra in which the conjunctiva is affected. It is very similar to the tubercle-bacillus, but rather longer, measuring from 4 to 6  $\mu$ , and not curved. The study of this individual can best be made by means of sections through the nodule, colored with hot carbol-fuchsin for fifteen to thirty minutes, washed in water, and differentiated for forty-five seconds with Gabbett’s solution. After this the section should be washed in ninety-five-per-cent. alcohol, then in absolute alcohol, and cleared in xylol. The bacilli appear red and the tissue slightly blue. Cultivation of this bacillus is almost impossible, but has been accomplished by Neisser and by Bordoni-Uffredozzi on gelatinized blood-serum and boiled eggs. When thus cultivated, Neisser found that the bacilli grew as long threads and developed spores. But this lacks confirmation. The rods have pointed ends, and often present unstained spaces similar to those seen in the tubercle-bacillus. In sections of tissue containing lepra bacilli they are seen to lie in and between the cells, being very numerous in the large cells. So far, inoculation experiments have failed.

*Bacillus Mallei* (Löffler and Schütz).—In this most virulent and, fortunately, rare disease the conjunctivæ and lacrymal tracts are affected, most probably by direct communication from the nasal lesions. The mucous membrane of the ocular apparatus becomes injected and swollen, secretes a muco-purulent fluid, and is often the seat of the characteristic pustular lesions of glanders. The bacillus at present recognized as the

etiological factor in this disease was discovered in 1882 simultaneously by Bouehard, Capitan, and Charrin, in France, and by Löffler and Schütz, in Germany. The former observers were not able, however, to separate it from the pus microbes found in the lesions, and to Löffler and Schütz is due the credit of having obtained the first pure culture of this bacillus,—the bacillus mallei. It is found abundantly in the interior of the glanders nodules, in the pustules upon the ulcerating surfaces, and to a less extent in the purulent secretions.

It is an aerobic, facultative anaerobic, non-motile bacillus, 5 to 7  $\mu$  long and 0.5 to 1.5  $\mu$  thick, resembling, therefore, in size the bacillus tuberculosis, but being somewhat thicker. The rods are straight, or sometimes slightly curved; in old cultures they may occur in large and irregular involution forms. They are generally isolated, but may be in pairs or even chains of two or three elements; and in tissue they show a certain tendency to form into small masses. Baumgarten claims to have stained spores by the Neisser method; but it is a question if such exist. Löffler found this micro-organism to be extremely susceptible to the several thermal, chemical, and mechanical destructive agencies. This, he argues, militates against the existence of spores. The bacillus does not take up the stain homogeneously, but presents feebly- or non-stained portions, alternating with the more deeply stained cell-contents. These are held by Löffler to be a degenerative change in the cell-protoplasm.

The bacillus of glanders may be stained easily, but not intensely, by the ordinary aniline dyes, and especially by those which are slightly alkaline. The stain to be used by preference is Ehrlich's methyl-violet solution, to which has been added just before using an equal part of 0.01-per-cent. solution of potassium hydrate. The microbe loses its color by treatment according to Gram's method, and also by use of the decolorizing solution of Ehrlich's method of staining the tubercle-bacillus, this serving as a means of differential diagnosis from that organism.

In staining tissue, Kuhne's methylene-blue gives good results. The sections are transferred from water to a carbolated solution of the blue (methylene-blue 1.5, alcohol 10, carbolic acid 5, water 100). After having been stained by four or five minutes' immersion, they are decolorized rapidly in water containing a little hydrochloric acid and washed in water. Quickly dehydrated in alcohol, they are passed through aniline oil and mounted in balsam.

Löffler's methylene-blue solution and a decolorizing mixture of ten cubic centimetres of water, two drops of sulphuric acid, and one drop of a five-per-cent. oxalic acid solution may be used.

The color is quickly lost in these decolorizing solutions, and consequently the staining in tissue is rendered most difficult. For purposes of diagnosis it is better not to rely upon the staining peculiarities of the bacillus, but to have recourse to cultures upon the different laboratory media.

These are very characteristic, and aid one to recognize definitely the microbe in question. To obtain a pure culture direct from the local lesion is somewhat difficult, owing to the presence of more rapidly developing micro-organisms and to the relatively small number of specific bacilli in the discharge. Therefore it is better to follow out the method employed by Strauss. This consists in injecting into the peritoneal cavity of a male guinea-pig some of the suspected pus. If it is from a case of glanders, a few days will suffice to set up a characteristic orchitis, the testicles containing a nearly pure culture of the bacillus.

The bacillus mallei grows best at 37° to 38° C. Below 22° and above 45° its development ceases, and at 55° its death ensues.

In bouillon and liquefied gelatin it forms at first a general cloudiness, which gradually settles down in the tube as a white viscous mass.

Upon agar the stroke at the end of a couple of days' exposure to the temperature of 37° C. presents a series of small, grayish-white, isolated droplets, which, as time goes on, gradually coalesce and form a white band two or three millimetres in width.

Agar to which has been added a small quantity (one per cent.) of glycerin is a more favorable soil, the growth taking place even at the ordinary room temperature. At the end of forty-eight hours there appears along the stroke a pale white, semi-transparent band two to three millimetres in width, which is increased at the end of a week to seven or eight millimetres.

On agar made with milk the bacillus grows most luxuriantly (Raskins). Upon this there is rapidly developed a thick, pale whitish layer, which on the third or fourth day assumes an amber-yellow and later a reddish-brown tint.

On blood-serum it grows as small, transparent, yellowish drops, which at the end of a week coalesce to form a creamy-white layer. This milky appearance is due to the presence of numerous minute crystals of unknown composition.

The growth on potato is most diagnostic. At the end of two days the surface of the medium is covered with a thin, yellowish, semi-transparent layer, which gradually assumes an amber color. In about seven days this growth becomes more opaque and of a reddish-brown tint, and is surrounded by a greenish zone in the substance of the potato. At this stage it somewhat resembles the potato culture of the bacillus pyocyaneus,—the bacillus of blue pus,—but this latter has a mother-of-pearl brilliancy and when treated with ammonia gives the blue color of pyocyanin.

In hay and similar vegetable infusions the bacillus does not develop.

In his investigations concerning the resistance of the bacillus mallei, Löf-  
fler found that it was destroyed in five minutes by a three- to five-per-cent. solution of carbolic acid, in two minutes by a one-half-per-cent. solution of mercuric bichloride, and in ten minutes by water at a temperature of 55° C. These facts have a bearing on the possibility of practical disinfection.

*Bacillus Megatherium* (De Bary).—This individual was met once in a case of trachoma and once on the normal conjunctiva.

The bacilli are very large, measuring from 0.8 to 1.0  $\mu$  in breadth and from 1.75 to 3  $\mu$  in length. The ends are rounded, except when chains are formed, when they may be flattened at the junctions. Involution forms are very common. One of the peculiarities of the species is to have a granular protoplasm, the granules being much more obvious in stained than in unstained individuals.

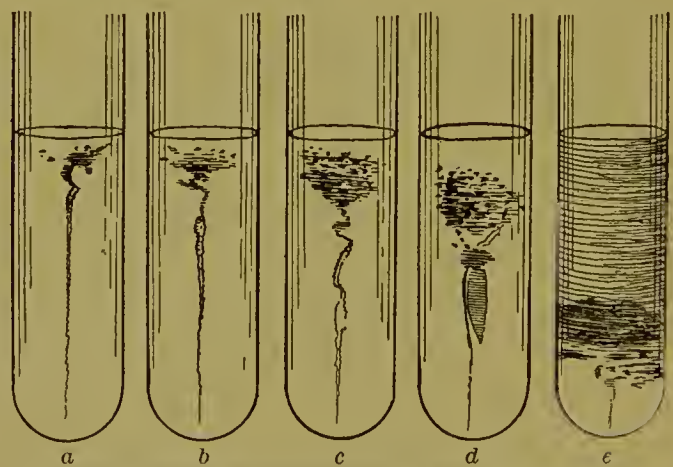
The organism appears to be without motility, except a peculiar amœboid change of shape, which, though rather rapid and easily observed, does not seem to allow of a distinct change of place. While watched, the bacilli may be seen to curve upon themselves, to project hook-like pseudopodia from their sides, and to take on other amœboid shapes.

The organism stains well with the aniline dyes when in good condition, but the involution stages, which are frequent, prevent the clear picture presented by other micro-organisms. In stained specimens the granules in the protoplasm often become unusually prominent. This is particularly true of Gram's method, which seems to color only these granules, presenting a most interesting picture, the bacilli being colorless, but its granules deep blue.

Upon gelatin plates the colonies appear in twenty-four hours as small, spherical, circumscribed, coarsely granular, colorless masses. Those near the surface begin to spread out and surround themselves with a halo before attaining any considerable size. In forty-eight hours the halo presents a cotton-like, filamentous character, in which no individual filaments can, however, be made out, but which gives to the whole mass a resemblance to a little bunch of raw cotton upon the surface of the gelatin. This appearance increases a little as the size of the colony increases, then is lost in the liquefaction, which becomes rapid after about seventy-two hours.

In gelatin punctures, at the end of about twelve hours a very small whitish surface-growth occurs, which soon sinks into a funnel-shaped area of clear, liquid gelatin, and then often develops a somewhat branched form like cauliflower. Thus far the growth has attained no magnitude. It continues a slow development, liquefaction continuing slowly in the puncture, until in five days it reaches the sides of the tube and extends half-way to the bottom. The liquid is full of flocculi,

FIG. 3.



Cultures of bacillus megatherium in gelatin.—a, 24 hours, b, 3 days, c, 6 days, d, 2 weeks, and e, 1 month old.

and at the apex of the funnel the flocculi begin to pile up. In four weeks the liquefaction has formed a horizontal plane about two-thirds of the depth of the gelatin, and shows the flocculi all precipitated, leaving clear fluid above. Seven or eight weeks elapse before the gelatin is entirely liquefied. No gas-bubbles are developed either in ordinary gelatin or in gelatin to which glucose has been added.

Upon the surface of agar-agar the growth develops with considerable rapidity. It rarely forms a uniform band along the line of inoculation, but generally occurs in isolated patches which may later become confluent. It is smooth and shining—rather doughy—in appearance, and is dirty-yellow or brownish-yellow in color. It seldom attains any size before the surface becomes mottled with minute brownish patches, which give the impression that bubbles have burst upon the surface, or that it is ulcerated. At the time when this mottling occurs the agar-agar becomes brownish-yellow in the neighborhood of the growth.

Upon the surface of potato the growth is luxuriant, forming a circumscribed yellowish-white mass, which is sometimes irregular and dendri-form, at other times without any tendency to spread at the edges. The growth generally attains a considerable thickness, projecting from the culture medium for one-eighth of an inch or more, and in some cases is dimpled, so as to suggest impressions of Oriental characters in plastic material. When examined beneath the microscope, the growth appears finely granular; to the naked eye it is smooth and lustrous.

In bouillon, at the end of forty-eight hours the growth is obscured by a general turbidity of the liquid and by the formation of an irregular fenestrated pellicle upon the surface. This condition does not change in the course of several weeks. There is no true mycoderma, and the surface-growth does not sink, as is so common.

The alkalinity of litmus milk is intensified. After three weeks the casein of the milk becomes digested, and the color, which has gradually faded, is lost. The bacillus is not pathogenic.

*Bacillus Mesentericus Vulgatus*.—This bacillus is one of the most frequent micro-organisms found on the conjunctiva; and as it is one of the ordinary denizens of the atmosphere, the reason for its frequency is readily understood.

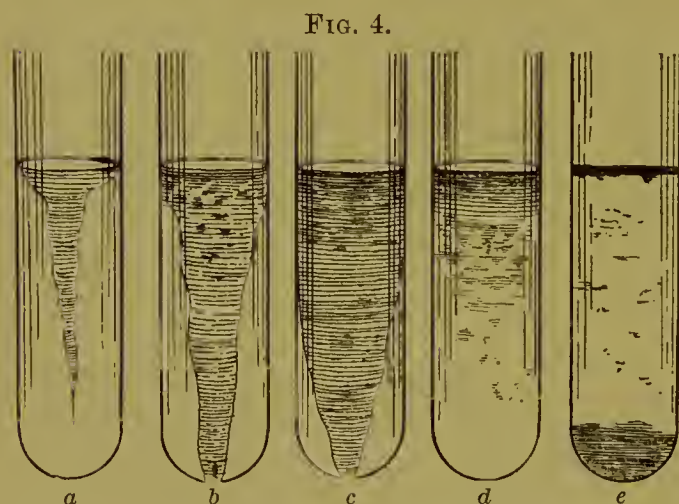
The bacilli are rather large and stout, measuring about 1.75 to 2.5  $\mu$  in length and .75  $\mu$  in breadth, having rounded ends, constantly uniting in twos, threes, and longer chains, forming myriads of spores of considerable size and oval form, and being possessed of motility which is seldom very rapid. The movement is generally sinuous, and not infrequently the individuals turn over and over in their progress from place to place.

The bacillus stains well by the methods ordinarily employed, and also by Gram's method.

When cultivated upon gelatin plates, the colonies appear with great rapidity, grow very rapidly, and prove rather troublesome by the extensive

and rapid liquefaction which is produced. The first appearance, which presents itself in a few hours, is that of a spherical, colorless, circumscribed body; but this is of short duration, and soon delicate offshoots, like a fringe, begin to develop around the colony. Sometimes liquefaction begins almost immediately, and at once spreads, so that the colony presents a saucer shape, attaining a diameter of from 3 to 5 millimetres, consisting of grayish or whitish, flocculent, liquefied gelatin, the edges of which show a delicate fringe extending into the normal gelatin. Other colonies are observed which pursue a different course. In these the fringe develops around the tiny colony as usual, but grows longer, long, radiating filaments being given off, and liquefaction not seeming to occur for twenty-four hours, after which, however, it spreads rapidly and takes the normal course.

When puncture cultures are made in gelatin, the liquefaction, which is in the form of a funnel, begins almost immediately, and occurs along the whole length of the puncture. The liquefied area attains considerable size in twenty-four hours, reaches the sides of the tube in forty-eight hours, is complete in three days, and has a varying character,—at first consisting of slightly eluded liquid, then of clear liquid containing numerous flocculi, the latter character developing about the time that the liquefaction is com-



Cultures of *Bacillus mesentericus vulgaris* in gelatin.—*a*, 24 hours, *b*, 48 hours, *c*, 3 days, *d*, 6 days, and *e*, 1 month old.

pleted. At the same time that the turbidity gives place to flocculi a pellicle begins to form on the surface. This soon forms a complete mycoderma, having a white color and becoming more and more dense, and finally forming a very wrinkled and tuberculated layer, which projects above the surface of the liquid at the sides of the tube. Later the under surface becomes somewhat yellowish. While this my-

coderma formation has been going on at the surface, the flocculi have been precipitated to the bottom, so that by the time it is complete it covers a perfectly clear liquid, below which a small sediment is observed. Should the tube be agitated so as to separate the mycoderma from its sides, the growth sinks, and may or may not be replaced by a new one.

Upon agar-agar the growth is not luxuriant, but forms a translucent, colorless band about 0.5 centimetre in breadth, extending the whole length of the stroke. This growth has circumscribed, slightly rounded, sometimes elevated edges, and is characterized by frequent transverse foldings, which give it the appearance of the segments of a tape-worm. In the lower part of the tube, if water is present, it forms a mycoderma upon it possessed of



the same characters as that described as occurring upon the surface of the liquefied gelatin. When touched with the platinum wire the growth is brittle.

The growth on potato is, of course, familiar and characteristic. Along the line of inoculation it occurs with luxuriance, producing a dull, rather dry, convoluted mass, which is thrown into innumerable folds and puckers. It does not tend to spread over much surface, but is considerably elevated, and suggests the appearance of a chain of rugged mountains on a relief map, especially when viewed with the lens. The growth on potato has a putty color, sometimes has a smooth shining surface, but generally is dull, this depending on the moist or dry condition of the potato. Age does not materially alter the character of the growth, which does not change at all in two weeks. Potato cultures give off a peculiar, disagreeable, pungent odor, which sticks to the fingers and is washed off with difficulty.

When grown in bouillon the liquid becomes cloudy, a mycoderma like that already described forms upon the surface, the cloudiness changes to flocculence, and precipitation of the flocculi occurs, so that the cycle of development is in all points identical with that in the liquefied gelatin.

In gelatin to which glucose is added no fermentation is produced.

When cultivated in litmus milk no change occurs for nearly a week, when the surface begins to show a deeper shade of blue. Coagulation, digestion of the coagulum, and total disappearance of color follow; but when the remaining colorless fluid is tested with litmus paper it is found to be strongly alkaline.

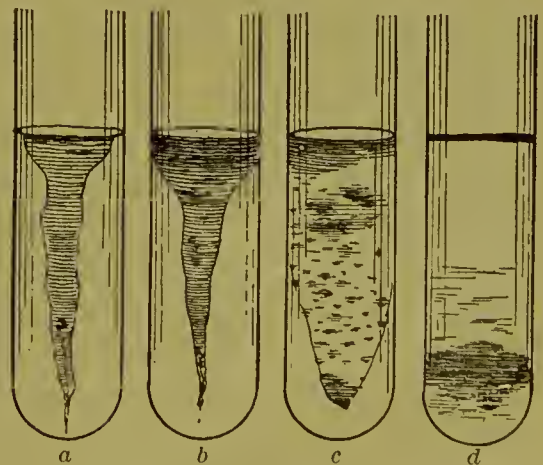
Blood-serum is liquefied by the growth of this organism.

The bacillus is entirely free from pathogenic properties.

*Bacillus Mesentericus Fuscus* (Flügge).—This bacillus seems to be identical with the bacillus mesentericus vulgatus in all points except its growth on potato.

When so grown, instead of a circumscribed elevated growth, this bacillus spreads rapidly over the surface of the culture medium, forming a yellowish-brown layer, thin, and covered with innumerable fine wrinkles. The general surface is smooth, the edges ill defined. As the growth increases in age it develops a greasy appearance, and when it begins to dry takes on a characteristic parchment-like quality. Like its close ally, the bacillus mesentericus vulgatus, its cultures give off a disagreeable, pungent odor. On agar-agar the translucence is less marked, and instead of the segmented tape-worm the growth is apt to be homogeneous, china-white, turning yellowish, and darkening the agar-agar as it becomes old.

FIG. 5.



Cultures of bacillus mesentericus fuscus in gelatin.—a, 48 hours, b, 3 days, c, 6 days, and d, 30 days old.

*Bacillus Mesentericus Ruber* (Globig).—Another frequent inhabitant of the air, and one similar in characteristics to the preceding varieties, is the rose-colored bacillus mesentericus. Slightly larger than the common variety, this microbe is not very mobile, generally occurs in chains of three or four elements, and produces large oval spores.

Its growth on gelatin plates and tubes resembles that of the vulgatus, liquefaction, however, being much slower.

On agar-agar and on potato the growth takes on the characteristic rose tint. The culture becomes folded, and is not adherent to the culture medium.

In bouillon a mycoderma is formed, but the liquid is not discolored.

*Bacillus of Measles* (Canon and Pielicke).—In the *Berliner Klinische Wochenschrift* (page 370, 1892), Canon and Pielicke describe a bacillus found in the blood of fourteen cases of measles. This is of varying length, often as long as the diameter of a red blood-corpuscle, often so small as to resemble a coccus. It stains best by the use of Czenzynke's fluid, as described for the bacillus influenzæ (page 504), and is decolorized by treatment by Gram's method. The authors found it in the blood of all the cases examined, and through the entire course of the disease; in one case even three days after the disappearance of the fever. They were unable to cultivate it on gelatin, agar, glycerin agar, or blood-serum. In these cases, however, bouillon, to which a little blood had been added at the time of the inoculation, developed after several days a slight flocculent turbidity. An examination of this showed microbes of similar character, but not susceptible of further cultivation. The bacillus was also found in the sputa and in the nasal and conjunctival secretions.

The question of its pathogenesis is still *sub judice*, and is regarded by many (Baumgarten) as doubtful.

*Bacillus Mycoides* (Flügge).—This bacillus was found once in a case of lacrymal obstruction.

It is a long, rather delicate bacillus, which tends to grow into very long filaments. When cover-glass preparations are made from the bacillus as it grows on agar-agar, it is seldom found in chains of more than four or six constituents. Each individual is about  $.8 \mu$  in width and from  $1.75$  to  $2.75 \mu$  in length. In many of the bacilli, but more often lying free, large numbers of oval spores can be observed.

When examined in the hanging drop, the individual is found to be without motility.

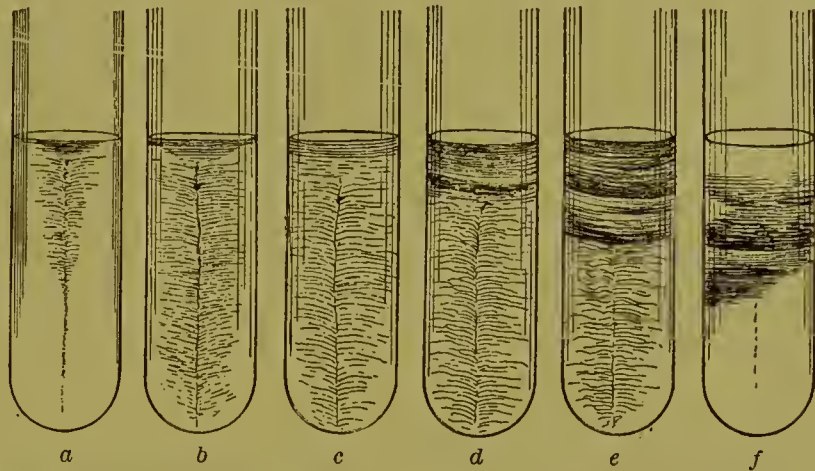
It stains readily with the ordinary aniline dyes and also by Gram's method.

Properly speaking, there are no colonies resulting from the growth of this individual. After about twenty-four hours, inspection of a gelatin plate will reveal a slight cloudiness to the naked eye, and here and there irregular, shapeless, whitish, translucent spots of small size can be observed. These are the actual colonies or points from which the original growth

takes place. Upon microscopic examination, the entire plate is found to be an immense net-work of intertwining and crossing filaments. The spots marking the original foci of growth are not distinct colonies, but simply points where large numbers of filaments meet and cross one another.

When a puncture is made in gelatin, a highly characteristic and beautiful growth results. In a few hours a slight dulness of the surface occurs, showing that growth has begun there, and at the same time there can be seen, radiating from the puncture on all sides, innumerable fine lines, so delicate as to escape observation except when carefully looked for. These filaments pass horizontally to the sides of the tube and incline a little

FIG. 6.



Cultures of bacillus mycoides in gelatin.—*a*, 24 hours, *b*, 48 hours, *c*, 3 days, *d*, 7 days, *e*, 2 weeks, *f*, 1 month old.

upward. In two days the whole surface of the gelatin is covered with a delicate membrane, beneath which is a small liquefied area. In three or four days one is surprised to find the entire gelatin liquefied, and the mycoderma, which is now a heavy and dense membrane, umbilicated at the centre, separating from the sides of the tube and sinking in the liquid. As the membrane sinks, it pushes down the growth in the liquid below it, causing all the delicate prolongations to have a very much more marked upward inclination. A new mycoderma forms, sinks, and is replaced by a third. No more than three were observed. The last mycoderma also sinks, and leaves a tube of uncovered, clear, fluid gelatin, at the bottom of which the mycodermata appear in perfect condition.

Upon the surface of agar-agar the growth is no less characteristic than upon gelatin. A rapid development occurs along the line of inoculation, forming an irregularly circumscribed, white, knobby band with frequent joints. From both sides of this woolly processes extend outward and downward, giving somewhat the figure of a leaf with its central vein and numerous lateral branchings. When touched with the platinum wire the growth is slightly tenacious.

Upon potato the growth is rather extended, colorless, covered with short tuberosities, and tending when old to become scaly in appearance. It is

dull and dry in character, the edges being thin and drying first when the culture ages, and having then a white color which contrasts with the central growth.

As upon the surface of the liquefied gelatin, so upon the surface of the bouillon a mycoderma forms. This sinks, is replaced by a second, this by a third, then all sink to the bottom, and the liquid is free on the surface or is covered by an imperfect reticulum. The liquid remains clear.

Added to gelatin, glucose causes no gas production.

In litmus milk, on the seventh day coagulation occurs, accompanied by loss of color. The casein is digested, and a gelatinous, colorless fluid remains which is strongly alkaline in reaction.

*Bacillus of Pink-Eye* (Weeks).<sup>1</sup>—This bacillus was impossible to separate from a larger species of club shape which was constantly found with it. In investigating the disease called pink-eye, this bacillus was found aggregated on and in the pus-cells and free in the mucus. It stained with the ordinary dyes, appearing as a tiny organism, resembling mouse septicæmia, 1 to 2  $\mu$  long and 0.25  $\mu$  in diameter. It is of about the same thickness as the tubercle-bacillus, but is shorter. Sometimes threads are formed, the separation of individuals being distinctly marked. It stains well by Gram's method.

When attempts were made to cultivate the individual, peculiar difficulties were met. No pure cultures could be obtained. In one-half-per-cent. agar-agar the bacillus developed very feebly. On one-per-cent. agar-agar it died out in a few days. It would not grow on plates. In beef-tea it grew fairly well, constantly mixed with the club-shaped bacillus. On potato the growth was scant.

The growth secured upon weak agar-agar was pearly in color and glistening on the surface. By the formation of concentric colonies, it extended for a short distance into the puncture made in the agar-agar, and reached its height in from five to seven days. The bacillus then began to degenerate, breaking up into small particles, which took the stain poorly. The growth never developed at the temperature of the room.

That this bacillus, and not the club-shaped bacillus which contaminated it, is the specific individual of pink-eye is shown by the experiments made with the latter, which was with ease cultivated and produced no pathological changes.

Weeks says that he has cultivated four forms of bacilli and five varieties of cocci from the conjunctival secretions, not including the coccus of Neisser and the one recently described by Michel as the causative agent in trachoma.

*Bacillus Prodigiosus*.—This organism, which has pronounced characteristics, is generally found distributed, in nature, upon substances which con-

---

<sup>1</sup> New York Medical Record, May 21, 1887; Archives of Ophthalmology, New York, 1886, vol. xv. p. 441.

tain starch, such as bread, freshly-starched clothing, etc.; but sometimes it occurs upon other substances, as meat, boiled potato, and in milk.

The organism is an extremely minute bacillus, sometimes uniting to form chains of ten or more members. It is very short, and formerly its oval form led observers to mistake it for a coccus. The length is always greater in individuals about to divide.

When studied in the hanging drop, the organism is found to form irregular chains, but often is isolated. If the medium in which it is cultivated be slightly acid in reaction, it may be observed that the individuals are longer than otherwise. No spores have been observed as yet. These bacilli show a distinct individual movement, but no cilia have been demonstrated.

The organism is a healthy and rapid grower, which soon forms large, deep, purplish-red patches upon the surface of the culture media, and when accidentally diffused through the dust of the laboratory becomes a nuisance. Fraenkel points out the peculiarity, which few other organisms possess, of growing much more rapidly at the temperature of the room than at the ordinary incubation temperature of 37° C.

Upon gelatin plates the colonies assume a variety of appearances, which must be carefully watched because of the rapid liquefaction which occurs. Their first appearance is that of minute white points, which can be made out by the naked eye. Under the microscope these are seen to be of a brownish-green color and a round form, and to have irregular borders. The superficial colonies begin to cause liquefaction of the gelatin before they attain any considerable size, and produce slight depressions, which later have a deep-saucer shape. As the liquefaction progresses, the characteristic color—a deep purplish red—begins to develop in the liquefied area. When the colony has attained an age of twenty-four hours the naked eye can make out the saucer-shaped depressions, at the bottom of which almost colorless clumps of organisms are seen surrounded by the reddened gelatin. The liquefaction progresses with great rapidity, and the plate soon becomes useless. Upon agar-agar plates the colonies spring up as colorless, circular, whitish or pinkish, smooth, shining masses, which begin to take on the dark brick-red color when they attain the size of a pin's head. When the plates are kept in the cold, the pigmentation occurs more rapidly than when the room is hot and the plates are kept in it or in the incubating oven.

Gelatin punctures suffer a very rapid and wide-spread liquefaction in the funnel form. The liquefaction has no special peculiarities, and is pretty far advanced before the pigment formation begins. The color is first seen at the surface, where an irregular film forms, fragments sinking from time to time, so that a reddish granular precipitate accumulates at the bottom of the tube. The most intense color always remains at the surface.

Upon agar-agar a rapid growth takes place along the whole line of inoculation, spreading rapidly and forming a purplish-red layer of considerable extent and thickness. The surface is smooth and shining, and, as the culture becomes older and a little dry, assumes a metallic lustre resembling

that of the aniline dyes. When water of condensation is present in the tube, the growth accumulates at the bottom of it as a powdery precipitate which has more of the purple about it than has the dry growth higher up.

The surface of potato is rapidly covered with a blood-red growth which lacks peculiarities other than its color and the formation of a metallic lustre like that described as occurring on agar-agar.

In bouillon the growth resembles that in the liquefied gelatin. The liquid becomes uniformly clouded; the red color occurs first upon the surface, and subsequently sinks, with the collection of a moderate amount of precipitate.

In milk the casein is slowly coagulated and the culture gradually assumes a deep-red color.

In solutions containing sugar, alcoholic fermentation is brought about.

The micro-organism has no pathogenic properties for man or for animals, but is peculiar in influencing the action of other organisms. Pawlowski has proved that if rabbits are simultaneously inoculated with anthrax and prodigiosus they may recover from the anthrax; and Roger found just the opposite of this,—that when animals immune to malignant œdema were simultaneously inoculated with prodigiosus they would contract the disease. There have been numerous investigations upon the pigment production of the organism. The pigment seems to be distributed through the protoplasm as minute granules, generally near the capsule. Light seems to have no influence upon the chromogenesis.

*Bacillus Pneumoniæ* (Friedländer).—This micro-organism was discovered in 1882 by Friedländer, who at that time attributed to it the specificity of croupous pneumonia. Since then, however, it has been shown to occur in but a comparatively small proportion of such cases, and its presence is now regarded as accidental, although of pathogenic significance. It is rather often found in the nasal secretions, in acute coryza, and in acute otitis media, and has also been described as occurring upon the conjunctiva and in the lacrymal tract.

In form the microbe is a bacillus varying in length from 1 to 2  $\mu$ , and is about 0.8  $\mu$  in thickness. In tissue and in secretions it is surrounded by a capsule whose staining peculiarities are similar to those of the bacillus lanceolatus. It is aerobic, facultative anaerobic, and non-motile, and no spores have been observed in it.

In general it takes on the stains in the same way as the lanceolate bacillus, but it is distinguished from this latter by being decolorized by Gram's method of treatment.

It begins to develop on nutrient media at a temperature as low as 15° C., while its growth ceases at 40° C., and its thermal death-point is at 56° C.

In gelatin plates it forms small, round, granular colonies, with sharp borders, which appear yellowish by transmitted light. Upon the surface of the medium the forms are thicker and more luxuriant, larger, hemispherical in shape, and of a porcelain-white color. They do not liquefy the

gelatin. On agar-agar, round, opaque, shining white colonies are produced in twenty-four hours, which soon coalesce and form a thick white band along the line of the inoculation needle.

On potato a similar growth, but slightly yellow in hue, occurs, which, especially in cultures at brood temperature, contains small bubbles of gas. The growth gradually invades the whole surface of the tuber.

Upon the surface of Löffler's blood-serum there is developed a thin, whitish, non-liquefying layer. In upright gelatin tubes there take place the characteristic "nail-head" growth and a luxuriant growth along the inoculation canal, composed of numerous small white colonies. In bouillon there is generally no cloudiness of the liquid; if such be present, it is exceedingly slight, and in twenty-four hours will have subsided, forming a small clotted deposit at the bottom of the tube.

*Bacillus Pyocyaneus* (Gessard).—This microbe was first found in green pus. It has since then been discovered to be one of the more common of the pus-producing germs, and was obtained by one of us in the secretions from a case of purulent conjunctivitis. The microbe is a small bacillus, about 1  $\mu$  in length and 0.3–0.4  $\mu$  in breadth, occurring singly, often in pairs, or even in chains of three or four elements. It is motile, aerobic, and facultative anaerobic, and liquefies gelatin. Spore-formation has not been observed, and its motility is due to a single terminal flagellum.

The microbe colors well with aniline dyes, and Gram's method gives negative results.

Upon gelatin, at the end of a day there appear numerous deep colonies, spherical granular, with serrated margins, and having a greenish-yellow tinge. On the surface these spread out into flat, thin, finely granular colonies, with more opaque and greenish centres. Liquefaction commences about the second day, and in a week the whole plate is liquefied.

In gelatin tubes there is at first a funnel-shaped area of liquefaction, which gradually increases to the complete liquefaction of the whole medium. The growth itself, which is white, sinks to the bottom of the tube as a white flocculent deposit, and the liquefied gelatin takes on a fluorescent green color, especially in the upper layers in contact with the atmosphere.

On solidified agar-agar there occurs a thin, flat, white, viscid band, mottled and moist, with sharp but irregularly scalloped edges. The medium becomes fluorescent and green. In old cultures the color becomes very dark and even brownish black, and the growth has by reflected light a mother-of-pearl appearance.

Blood-serum cultures have a similar appearance, the color being, however, a blue-green and the medium becoming liquefied, old tubes containing liquid dirty yellow in tint in the lower portion, with blue-green upper layers. Litmus milk is gradually decolorized from above downward without any coagulation. At the end of a week it is a dirty-yellow, clear liquid, with dense white flocculent deposit, and having a reddish ring around the upper portion of the tube.

Bouillon in a few days is clouded, and a delicate white mycoderma is formed on the surface. With age the cloudiness falls down as a fine flocculent deposit and the medium takes on a yellowish-green tinge.

On potato a characteristic glistening reddish-brown growth develops. The tuber sometimes becomes of a green color, sometimes remains colorless. In the presence of ammonia the growth assumes a green tint, and on the addition of acid it becomes red.

This characteristic coloring of the several cultures of this micro-organism is due to the presence of two pigments, a blue pyocyanin and a yellow-green fluorescin. The several media of culture determine the relative amounts of each, and Gessard has thus cultivated different varieties of the organism. One of these, produced in alkaline two-per-cent. peptone solution to which five per cent. of glycerin was added, gives pyocyanin only; a second, grown on egg albumin, produces the fluorescent green pigment; and a third, from cultures exposed to a temperature of 57° C. for five minutes, is perfectly colorless.

The green color is formed only in presence of oxygen, and is soluble in chloroform. All the cultures exhale a very characteristic slightly faecal odor.

Besides the local pyogenic action of the bacillus pyocyaneus, it may also determine a general infection, death occurring from a hemorrhagic sepsis.

*Bacillus Septicus Keratomalaciæ* (Babes).—This bacillus was obtained by Babes from the broken-down corneal tissues and from various organs of a child who died of septicæmia following keratomalacia.

It stains with the usual aniline dyes. Deeply stained granules may be often seen at the ends of the rods or in the middle in preparations stained with Löffler's fluid.

The bacilli are short and thick, thinning out at the ends; often united in pairs; may be surrounded by a capsule.

It is an aerobic and facultative anaerobic, non-liquefying bacillus. Spore formation is not observed. It grows in the usual culture media at the room temperature. Upon gelatin plates it forms white, slightly elevated, flat colonies with finely dentated margins. In gelatin stick cultures the growth is abundant both on the surface and along the line of inoculation. Gas-bubbles are formed in the gelatin. Upon the surface of agar the growth along the line of inoculation is leaf-like, finely dentate, somewhat opalescent, and the culture has a slightly ammoniacal odor. Upon blood-serum a semi-transparent, glistening film is formed which has dentate margins.

It is pathogenic for rabbits and mice, less so for birds, and is not pathogenic for guinea-pigs. The animals die in from three to seven days. Inoculated into the cornea, it causes purulent keratitis.

*Bacillus Subtilis*.—This organism is one of the most common microbes found in the air, dust, water, etc. It is a long bacillus, averaging over 3  $\mu$



in length and being about  $0.7 \mu$  in thickness. Its motility is greatly due to the action of two long flagella, one at each end. It occurs either singly or in long chains, which are likewise motile, and bear spores which are of somewhat less calibre than the bacillus itself ( $2 \mu$  by  $0.6 \mu$ ). This organism is said to be a true aerobic, growing only in the presence of oxygen. It takes on the ordinary aniline stains with facility.

In gelatin plates there soon appear small, round, granular, yellowish colonies, which gradually increase in size and slowly liquefy the surrounding medium. In the midst of this liquefied area are small granular deposits, the remains of the original colony, while around the periphery there is seen a zone of minute radiating filaments projecting into the slowly liquefying gelatin.

In gelatin tubes the liquefaction is much more slow, scarcely any change of consistency being noted even at the fifth day of growth. On agar-agar there is developed a creamy or moist putty-like layer, often spreading and covering the entire surface. The border is thick, sharply defined, and irregular.

Bouillon becomes at first cloudy, but with the appearance of a thick, coherent mycoderma; this turbidity is precipitated as a fine flocculent deposit.

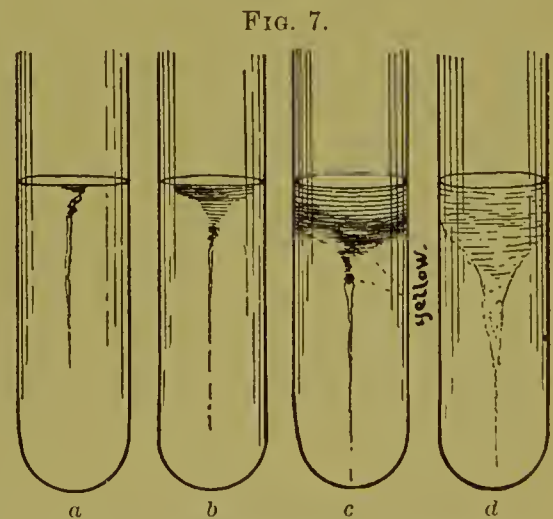
On potato the growth is similar to that on agar-agar, and has a dirty-white or slightly yellowish tinge.

Although this microbe has no pathogenic properties, it is of interest on account of its frequency and because of its probable identity with the so-called bacillus of jequirity infusions.

*Bacillus Sucinacius* (McFarland).—This small bacillus, measuring from  $1 \mu$  to  $1.75 \mu$  in length and from  $.3 \mu$  to  $.5 \mu$  in breadth, was found but once in the conjunctival secretions of a case of granular conjunctivitis. The organisms generally have rounded ends, occur isolated or joined in twos, and are peculiar in presenting many club-form and falciform individuals in comparatively fresh cultures, so that involution forms are very common. The organism seems to be non-motile, and no spores were observed in it.

It takes the aniline dyes rather badly, perhaps because of the rapid degeneration which it shows, and is not colored at all by Gram's method.

Upon gelatin plates the colonies are slow in developing, not appearing until from twenty-four to forty-eight hours. They are small, sharply circumscribed, spherical or round, yellow, translucent, and slightly granular, the granular condition being observed particularly in the centre, where they



Cultures of bacillus sucinacius in gelatin.—a, 2 days, b, 3 days, c, 4 days, and d, 6 days old.

present a partial resemblance to powdered glass, an appearance which becomes more marked as the colony ages.

In eighteen hours after a puncture is made in gelatin a minute depression may be seen on the surface. This increases in size, forming a cup or air-bubble, below which a delicate growth of microscopic colonies develops in the track of the needle. By the third day a delicate funnel of slightly clouded, liquefied gelatin is seen extending from the air-bubble, whose floor presents a yellowish surface-growth about one-fourth the depth of the gelatin and terminating in a sharp apex, in which a yellow powder collects. The growth increases in size, spreading to the sides above and gradually to the bottom, until at the end of four weeks the gelatin is entirely liquefied and a clear fluid remains with a yellow zooglear precipitate. No gases were produced in normal or glucose gelatin.

The growth on agar is very delicate, consisting of a narrow, transparent, orange or amber band along the whole line of inoculation. This band is of very equal breadth throughout, and the growth does not alter its character in the lower moist portion, nor does it spread upon or develop in the water expressed from the agar-agar. If this growth be viewed through a lens, it will be seen to be lobulated and a little thickened at its edges. When touched with the platinum wire it is found to be brittle, and can be picked up only with difficulty, because of its non-adhesive character. The growth took place best at room temperature.

Although numerous trials were made at all temperatures, the bacillus could not be induced to grow upon potato.

When planted in bouillon, the bacillus did not distribute itself through the liquid and cause turbidity or flocculence, but seemed to form small zooglear masses, which collected at the bottom of the tube, leaving the bouillon itself unchanged. The growth in bouillon seems to be scant.

Litmus milk becomes decolorized without any acid production. After the disappearance of the blue, a rapid growth of the bacilli occurs at the surface, forming an orange-yellow pellicle. Later the milk coagulated, the casein was digested, and when the remaining clear fluid was tested its reaction was neutral.

*Bacillus Syphilis* (Lustgarten).—The question of the presence of a specific organism in this disease is as yet undecided. Lustgarten has described a bacillus which he found in certain cases of syphilitic ulceration and in syphilitic discharges. It is an organism closely resembling the bacillus of tuberculosis in form and size, but differing from that microbe in its staining peculiarities. It is slightly irregular in outline, and is generally curved or bent. Clear unstained portions similar to those we see in the tubercle-bacillus are observable in this, but that they are spores has not yet been determined, although Lustgarten regards them as such. The method by which this investigator succeeded in coloring his bacilli in tissue is as follows. The section is placed for twenty-four hours, at a temperature of 40° C., in Ehrlich's gentian violet stain (aniline water, one hundred parts; saturated

alcoholic solution of gentian violet, eleven parts). Washed in alcohol, they are then decolorized by immersing them successively in a 1.5-per-cent. solution of permanganate of potassium and a weak watery solution of sulphuric acid. After being thoroughly washed in water they are dehydrated and mounted in balsam in the usual way. On examining such a section Lustgarten found his bacillus not free in the tissue, but contained within the cell in numbers from two to five.

As, however, no cultures have been obtained, and therefore its biology and pathogenic properties remain undetermined, and as many other observers have been unable to corroborate Lustgarten's discovery, we may consider the specificity of this micro-organism as not proved, and, indeed, as extremely doubtful.

*Bacillus Tuberculosis* (Koch).—This organism is found in the rather infrequent cases of lupus conjunctivæ and tuberculosis of the lacrymal apparatus. In lupus it generally occupies the cellular masses, and is so deeply situated as to be obtained only by curetting the diseased area. If some of the material thus obtained be reduced to a pulp, spread in a thin layer upon the surface of a clean cover-glass, and passed three times through the flame, the characteristic stain may define a very few organisms. In lupus, however, as the number of bacilli is always very small, much time will probably be spent before they are discovered.

The lacrymal apparatus may be affected independently of the conjunctiva: thus, Loidholt reports a case of tuberculosis of the sac in which bacilli were found, but in which there was no involvement of the conjunctiva, of the nasal mucous membranes, or of the skin.

The staining of the tubercle-bacillus is a simple matter, requiring only a few minutes' time and two reagents, and Gabbett's modification of the Ziehl-Neisser method is the one employed with the best results. Upon the prepared cover-glass is dropped enough of the following solution of fuchsin to cover it completely and to appear to be about to overflow: fuchsin, 1; alcohol, 10; five-per-cent. aqueous solution of carbolic acid, 100. Thus prepared, the cover-glass is gently heated until vapor arises, and this temperature is maintained for about five minutes. The stain is then poured off, the specimen given a pretty thorough washing in water, and an equal amount of Gabbett's solution dropped on: methyl-blue, 1 to 2; sulphuric acid, 25; water, 75. This is allowed to act for thirty seconds, and then washed off with water until only a faint bluish color remains. The specimen may be immediately examined in water or glycerin, or may be dried and mounted in Canada balsam.

If such a specimen be examined under an oil-immersion lens, it will be found that, while everything else has a delicate blue color from the methyl-blue of the Gabbett's solution, the tubercle-bacilli have resisted the decolorant action of the sulphuric acid, and appear as delicate red rods about 1.5 to 3.5  $\mu$  in length, generally slightly bent and showing more or less disposition to occur in pairs or small groups, with their long diameters side by

side. The bacilli which are partly degenerated or which are imperfectly colored exhibit a beaded appearance not unlike that of streptococci, stained areas alternating with colorless spaces. By some these clear areas are regarded as spores, but of this there is as yet little or no proof.

We would recommend the indirect method of cultivation, by which the conjunctival scrapings from the suspected case are introduced into the subcutaneous tissue or abdominal cavity of a guinea-pig. If tubercle-bacilli are thus introduced, in the course of two or three months the animal will sicken and die of general tuberculosis, and, as the cadaver presents abundant tubercular lesions, no trouble will be experienced in incising a tubercular mass with a sterile knife and removing some of its contents by means of a sterile wire to a tube of blood-serum or glycerin agar-agar. Tubercle-bacilli grow only at the temperature of the body, and are slow in their development, the colonies appearing in from ten to fourteen days as dry whitish scales or flakes considerably elevated above the surface of the medium, and showing no disposition to spread. Gelatin is unfitted for the cultivation of this organism because the elevated temperature at which it must be kept of course melts the medium, and not because there is anything unfitted for its growth in the gelatin. Melted gelatin containing from five to ten per cent. of glycerin, as well as beef broth or peptone solutions containing glycerin, are not inappropriate as culture media. It is even asserted by some that the tubercle-bacillus may be grown upon potato if the potato be hermetically sealed in a tube so as to be kept moist.

The bacillus is non-motile, and probably does not produce spores. The species can almost always be determined by its staining peculiarities, which are shared only by the bacillus of lepra.

*Bacillus Varicosus Conjunctivæ*.—Gombert found this organism in the healthy conjunctival sac of man.

The organism is a large bacillus with round ends, from 2 to 8  $\mu$  long and about 1  $\mu$  broad. The shorter bacilli are often constricted in the middle.

It stains with the usual aniline colors.

It is an aerobic and facultative anaerobic, liquefying, non-motile bacillus; grows very slowly in nutrient gelatin at 22° C., rapidly in agar and upon potato at 37° C. In gelatin stick cultures, at the end of twenty-four hours, a circular layer having a grayish-white centre is developed upon the surface, and a scarcely visible grayish-white thread along the line of puncture. Liquefaction extends gradually from the surface without clouding or changing the gelatin, so that at the end of two weeks the gelatin is entirely liquefied without giving any other evidence of the presence of the micro-organism. Upon agar-agar plates at 37° C. the deep colonies have a diameter of about four millimetres; by the end of the fourth day, under a low power, they can be seen to be covered with minute, irregular, thorn-like projections, which subsequently increase in size; the centre of the colony is granular and opaque.

The superficial colonies, under a low power, are seen to have an opaque

central nucleus, surrounded by a yellowish, finely granular, transparent peripheral zone; later the central portion is irregular and semi-opaque, surrounded by a broad marginal zone, which consists of twisted and bent, tapering offshoots having a dark contour. Upon the surface of agar a thin, white, dry, very adherent film is formed; a thick white film forms upon the surface of the condensation water. Upon potato, development is rapid at 37° C., forming at first a dry white layer, which at the end of ten days covers the entire surface; it then has an irregular surface and fringed margins, is smooth, dry, and, after a time, has a reddish-brown color.

*Pathogenesis.*—When inoculated into the cornea of rabbits, a grayish-white cloudiness is developed in twenty-four hours, around which the cornea is highly vascular. The animal recovers without the formation of an abscess. Injected into the conjunctiva, it causes an intense hyperæmia.

*Bacillus Violaceus Flavus* (McFarland).—This organism was cultivated from the conjunctiva of a case of granular conjunctivitis.

It is a short, oval bacillus, with rounded ends. It is actively motile, and forms chains of from two to eight, which are also motile. No spores could be observed.

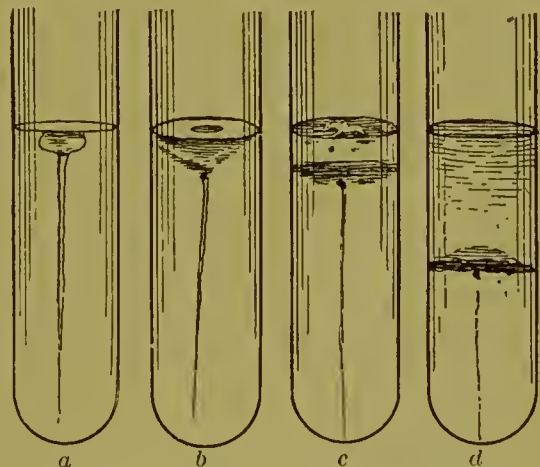
It stains well with the ordinary stains, and appears as in the hanging drop. It does not retain the color when stained by Gram's method.

In twenty-four hours the colonies appear upon gelatin as irregular, yellowish-white clumps with granular contents. They are circumscribed at first, but, as liquefaction comes on rapidly, are soon surrounded by a little zone of liquid, which is bridged over in many places by bristling fibres extending from the colony to the normal gelatin. These little threads are too small to be called processes or projections, but give the colony a rather bristling appearance.

In gelatin the development is rapid, a little cup of liquefaction being apparent in forty-eight hours. This cup increases in diameter more rapidly than in depth, reaching the sides of the tube in four or five days. At the apex of the cup an accumulation of the growth occurs, which not rarely presents a pink color, but sometimes is yellow. The liquefied gelatin sometimes has a delicate violet hue. The gelatin is all liquefied in about a month, and then presents a pink color in the upper fourth and a pinkish mycoderma on the surface.

Upon agar-agar the growth attains its very marked characteristics. Along the line of inoculation a rather delicate band of pink forms, smooth

FIG. 8.



Cultures of *bacillus violaceus flavus* in gelatin.—*a*, 3 days, *b*, 4 days, *c*, 6 days, and *d*, 14 days old. In *d* the superficial stratum is of a pinkish color, while the accumulated material at the bottom of the liquefied gelatin is bright yellow.

and glazed below, tuberculated above, and having distinctly circumscribed borders. This does not attain any considerable size before the agar itself becomes a beautiful violet, most marked at the upper part. Curious is the fact that the growth which takes place in the expressed water, and which appears as a powdery sediment, is invariably bright yellow. The violet color is much intensified when frequently transplanted to new agar-agar. When the cultures are old, the violet hue fades and the culture becomes yellowish-white.

The growth on potato is rather luxuriant, and of a dirty salmon color. Its only characteristic is a slight translucent effect.

In bouillon the growth occurs rapidly, producing turbidity. Soon the liquid assumes the violet hue, and a thin pink or violet mycoderma forms on the surface. The growth which precipitates is always yellow and powdery.

In litmus milk there seems to be a slight acid production.

*Proteus Vulgaris* (Hauser), *Bacillus d'of Fick*.—This bacillus was found twice by Fick, both times upon diseased conjunctivæ. Its peculiarities are well known, and it is an accidental organism upon the conjunctiva.

The bacillus is very short and delicate, measuring from 1.0 to 2.4  $\mu$  in length, the average being 1.2  $\mu$ , and about 0.5 to 0.7  $\mu$  in breadth. It varies considerably in appearance, sometimes being elliptical, sometimes elongated, with rounded ends.

The organism is actively motile, and perhaps produces spores.

It stains quite well with the ordinary dyes, but does not retain the stain when Gram's method is employed.

The characteristic appearance of the colonies takes place only upon five-per-cent. gelatin; at the end of six or eight hours careful observation will reveal small depressions in the gelatin. When magnified, these are seen to be colonies of bacilli, which, though thick in the centre, are observed to thin away at the edges until surrounded by only a single layer of bacilli. This outer zone gives off irregular processes like the pseudopodia of an amœba. These pseudopodia not only resemble an amœba in appearance, but are constantly seen to be changing their shape and position, and sometimes detach themselves from the main colony to lead a separate existence. After a time the whole surface of the gelatin is found to be covered by wandering amœba-like colonies. About this time liquefaction of the gelatin takes place, and progresses with great rapidity.

This picture does not occur when ten-per-cent. gelatin is used.

Upon agar-agar plates the colonies appear in twenty-four hours. They are circular, consisting of a central dark spot surrounded by a lighter zone. Frequently daughter colonies are observed to project from the parent colony. The deep colonies are spindle-shaped.

In gelatin puncture cultures a distinct colony is observable in twenty-four hours. In forty-eight hours liquefaction begins, and progresses in a funnel form. It not infrequently happens that in the puncture, at points

remote from the funnel of liquefaction which is progressing, discrete dis-associated areas of liquefaction spring up and subsequently unite. The liquefied gelatin is cloudy, and at the bottom of the tube a considerable amount of sediment collects. The cultures in process of liquefaction have a disagreeable smell.

Linear cultures on agar-agar show a grayish pellicle. These cultures also have the same foul smell that is observed in the gelatin.

A smeary semi-liquid layer occurs on the surface of blood-serum. The water of condensation is rapidly invaded, and in five days the cultures give off the peculiar odor.

Upon the surface of potato a dirty-white, moist layer grows luxuriantly. These cultures also have the odor in great intensity.

It is pathogenic for animals (rabbits and guinea-pigs), but not for man. Fiek found that when introduced into the eye it produced an acute conjunctivitis, and that it was capable also of bringing about a serious keratitis.

*Cladothrix Dichomata*.—One of the causes of obstruction to the tear-flow, and first described by Von Graefe, is that micro-organism formerly called the streptothrix foersterii. His description of this organism is insufficient, but it is probably that known as the streptothrix dichomata or, more properly, the eladothrix dichomata. (Cohn.) It occurs in the canal in the form of small chalky masses, often the size of a pea, and consisting of what seems at first a mass of closely intertwined filaments with dichomatous branching. Under a high power this is seen to be a false branching, the several elements being placed at an angle with each other, but separated by a clear space. The isolated filaments are about  $0.4 \mu$  in thickness, and vary in length up to  $40 \mu$ . They are straight or sinuous, or even spiral, in character, and are not motile. The ordinary aniline dyes stain them with facility. The growth of this eladothrix on culture media is characteristic.

In gelatin plates it slowly (in four or five days) forms small, yellowish colonies which are surrounded by a brownish discoloration of the medium. They are granular, and show numerous filaments which extend a short distance into the liquefying gelatin. This liquefaction takes place very slowly. The colonies gradually become covered with a fine, chalky, dust-like deposit.

In the tube of gelatin a similar growth takes place. At first there is a thin grayish skin formed upon the surface, with some few white colonies along the track of the inoculation needle. The gelatin is slowly liquefied and discolored. The growth itself becomes a whitish, flocculent mass, and sinks to the bottom of the dark-brown liquefied medium.

In bouillon there are formed the same white, flocculent masses, the fluid remaining clear.

On agar-agar the colonies are most characteristic. They are semi-transparent, yellowish, glistening, parchment-like, and round, are marked on the surface with concentric rings, and grow down into the medium. This

gradually assumes the same dark-brown color as gelatin, and the growth becomes covered with the same chalky deposit.

On potato there is a white skin-like growth, which takes on the chalk-like material and grows down into the substance of the tuber. This chalky material the microscope shows to be made up of short rods and of cocci, which are probably the forms of resistance of this micro-organism.

*Micrococcus Candicans* (Flügge).—Fick was successful in recognizing this organism ten times, the cultures being made from six normal and four diseased eyes.

The cocci are spherical, a little larger than the staphylococcus pyogenes aureus, and are frequently associated in irregular groups. The size varies considerably, but may be set down as from 0.8 to 1.2  $\mu$  in diameter. They stain well with the aniline dyes, and retain the color well when stained by Gram's method.

The colonies upon gelatin are cream-like in color, and appear under the microscope as shining, circular, finely granular bodies with jagged outlines. The deep colonies are quite different, and appear as finely granular dark-brown spheres.

In gelatin puncture cultures a confluent white rod is formed along the track of the needle, terminating above in a white, button-like growth on the surface. The growth is slow, and at least a week passes before the "nail-shaped" growth occurs. The gelatin is not liquefied.

Upon agar-agar a white, shining, almost homogeneous growth is produced.

Potato cultures are similar, and a luxuriant white mass speedily forms. Fick endeavored to produce inflammation of the rabbit's eye by introducing it beneath the corneal conjunctiva, but failed.

The organism is not pathogenic.

*Diplococcus Gonorrhœæ* (Neisser).—The gonococcus of Neisser is an organism whose presence upon the conjunctiva in cases of purulent ophthalmia very few can doubt, but whose positive demonstration is a matter of no inconsiderable difficulty, because, should one wish to stain it, it is most easily confounded with other cocci of similar shape which have exactly the same staining qualities; or should he desire to cultivate it, it is almost impossible to make it grow, while contaminating organisms of similar shape and size grow abundantly.

To find this important organism, a *perfectly fresh* case of purulent—*i.e.*, gonorrhœal—ophthalmia should be selected, and a drop of the lacrymal secretion from the most purulent area picked up with a sterile wire and spread upon a cover in a thin film. This is dried and fixed by passing it three times through the flame, and the stain poured upon the glass. The organism can be stained with the aqueous solutions of the basic aniline dyes, especially methyl-violet, gentian-violet, and fuchsine. Double staining may easily be accomplished by using methyl-blue and following by a weak solution of eosin. The organism does not retain the stain with Gram's method.



When successfully colored, the cocci appear of a biscuit shape,—like the German roll called “*semmel*,”—this form being the result of division without complete separation and isolation of the organism. The approximated surfaces are flattened. Sternberg gives the measurement of the length of an associated pair as 0.8 to 1.6  $\mu$  in the long diameter and 0.6 to 0.8  $\mu$  in the short diameter.

The cocci divide alternately on two planes, and for this reason tetrads are very common. The diplococci are, however, the more common form, and this form may be regarded as characteristic.

As has been said, the appearance cannot be taken as a reliable guide in the diagnosis. Bumm found other diplococci exactly like the gonococci in appearance.

As regards its vegetative properties this coccus is peculiar. It will not grow in gelatin, on agar-agar, or in bouillon, and grows less readily upon blood-serum prepared from the blood of animals than upon human serum. It will, however, grow upon animal serum and also upon Löffler's mixture. When a culture is required, the method of obtaining it is to select creamy pus from a perfectly fresh case, picking it up with a sterile platinum loop and depositing it upon the coagulated serum, so as to make little drops or smears rather than a surface smear or linear culture of magnitude. The cultures must be kept at the temperature of 37° C., and should not be allowed to remain for longer than eighteen to twenty-four hours. By this time growth will have begun, and from one of the little colonies a linear culture can be made in a fresh tube. The organisms grow very slowly along this stroke, and in two or three days cease to increase. Such a growth, if successful, will be about a quarter of an inch long, very delicate, of a yellowish-white color, and moist and shining. In a few days the cocci lose their vigor and become not only non-vegetative, but non-virulent, and eventually die. It is said that the gonococcus has been successfully cultivated upon the egg of the pewit and upon synovial fluids. Such media are rarely accessible, and will not meet ready acceptance. Upon the former of these the growth is said to appear in six hours and to spread rapidly, forming a thin, whitish, transparent layer. Bumm succeeded in producing gonorrhœa in two men into whose urethra he introduced these cocci. Their introduction into animals is without result.

Kroner<sup>1</sup> examined ninety-two cases of ophthalmia neonatorum and found the gonococcus “with perfect ease” in sixty-three of them. In other cases it was difficult to find, but was successfully demonstrated. Some of the cases examined were without the organism. His experiments were very thorough, for he also investigated the vaginal secretions of the mothers, demonstrating the infecting organism in eighteen out of twenty-one whose children were affected by the disease.

---

<sup>1</sup> Bericht über die Sitzungen der gynäkologischen Section der 57. Versammlung deutsche Naturforscher und Aerzte zu Magdeburg.

*Micrococcus Tetragenus* (Koch and Gaffky).—This large coccus is rather a rare denizen of the mucous cavities of the eye. It is a common organism in sputum, not only in that coming from the cavities of tubercular patients, but also in that of most pulmonary diseases, and is of common occurrence in normal saliva.

The coccus is of large size, and, while without any definite arrangement when grown in cultures, shows a characteristic grouping when found in the tissues of animals which have succumbed to it. In the tissues it is rather rare to find isolated organisms or masses; the general arrangement is in tetrads, sometimes in pairs, less frequently in triads. These small groups are surrounded by a homogeneous, gelatinous capsule, which does not take the stain, and which has much the same appearance as the capsule of the bacillus of pneumonia.

The organism is very easy to stain with the ordinary dyes, and makes beautiful specimens when stained by Gram's method.

When cultivated, the organism is rather luxuriant in its development. The colonies appear upon gelatin as small whitish dots, and soon extend upon the surface as porcelain-like, projecting, circular masses. Their growth is devoid of characteristics and does not alter the gelatin.

In puncture cultures in gelatin the growth occurs along the whole puncture as whitish, spherical masses. No liquefaction occurs. On the surface a considerable layer forms.

Upon the surface of agar-agar, and also upon blood-serum, the growth forms a smooth, shining, white layer of luxuriant development. The cultures on potato form a thick, slimy layer, which when touched with the platinum wire is adhesive and can be drawn out into threads.

The organism is pathogenic for white mice and guinea-pigs, which die in from three to four days of a general septicæmia. In these cases the organisms are found in the blood and tissues.

House-mice, field-mice, and rabbits seem to be naturally immune.

*Sarcina Aurantiaca*.—This organism is found upon the normal conjunctiva as an accidentally present, harmless, rather unusual coccus. It is also reported as occurring in trachoma, again accidentally, by Shongolowicz.

It is one of the forms of the cocci which are irregular in size, and, dividing in three directions, give rise to package forms which may be compared to bales of cotton tightly bound up. In stained preparations one sometimes finds isolated individuals, more frequently pairs, tetrads, or packages.

The organism is readily separated by its morphology and its color.

Upon gelatin plates small, spherical, granular, orange-yellow colonies are formed. Liquefaction begins about them rather slowly.

In gelatin puncture cultures liquefaction progresses slowly along the line of inoculation. When the liquefaction is complete, a yellow precipitate accumulates at the bottom of the tube.

On agar-agar the growth is abundant, moist, and shining, devoid of other peculiarities than its golden-yellow color.

On potato the growth is never so luxuriant as upon agar. It is slow in development, and is found along the line of inoculation.

*Sarcina alba* (Eisenberg) has also been found by Shongolowicz in the eyes of trachomatous individuals.

This organism forms small, white, spherical colonies upon gelatin plates. In gelatin puncture cultures a white button-like growth occurs at the surface near the puncture and covers it like a nail-head. The growth along the puncture is slow, and liquefaction comes on very late.

On agar-agar and potato the growth takes place rather slowly, with the formation of a yellowish-white layer, spreading slightly from the line of inoculation.

*Staphylococcus Cereus Albus* (Passet).—This is another accidental organism which Shongolowicz mentions as occurring in cases of trachoma which he investigated.

These cocci are large, measuring as much as  $1.15 \mu$  in diameter. They are sometimes found isolated, but generally occur in groups.

The colonies are said to attain a diameter of from one to two millimetres upon gelatin plates, and to resemble drops of stearine or wax.

In gelatin puncture cultures a grayish-white mass with irregular thickened margins, resembling white wax, forms upon the surface. The growth in the puncture is very scanty.

On agar-agar and potato the growth is a dirty-white layer of moderate thickness, devoid of characteristic features.

*Staphylococcus Pyogenes Aureus*.—This well-known pathogenic, pyogenic organism is no stranger to the conjunctiva, being found not only upon that membrane in the catarrhal affections, but also occasionally upon the normal membrane. The fact that it is not purely parasitic, but is capable of life as a saprophyte, makes it a pretty constant denizen of hospital and infirmary atmospheres; and, as the micro-organisms which are found in the conjunctival sac are those which accidentally blow in or are rubbed in by the fingers and handkerchief, it is by no means remarkable that this—one of the commonest—should be found there.

We have succeeded in securing from conjunctivæ in conditions of chronic inflammation a culture so virulent as to kill a dog in forty-eight hours. It is common in the normal eye, but generally in a somewhat attenuated form. When the presence of this organism is suspected upon the conjunctiva, and gelatin plates or dishes are prepared from a drop of the secretion, the colonies appear as small white dots (Fick says they look like drops of yellow cream), which later become more or less granular, turn yellow in the centre, and liquefy with great rapidity, so that in forty-eight or seventy-two hours the plate becomes useless. The deep colonies are fusiform or "wetzsteinförmig."

Gelatin puncture cultures liquefy with rapidity, a long funnel being formed in from twenty-four to forty-eight hours, and liquefaction being complete in six days. The fluid is at first turbid, but later becomes clear

by the precipitation of the suspended particles, which form a membrane-like layer upon the non-liquefied portion of the gelatin. As the culture continues to liquefy, the gelatin recedes from this layer, leaving a delicate, filmy, cobweb-like funnel or "stocking" suspended in the liquid. This becomes of a yellowish-"golden" color, and eventually sinks to the bottom as a precipitate. Liquefaction is much slower in slightly acid gelatin than in neutral or alkaline.

Upon agar-agar development is not luxuriant; it occurs along the stroke as a moist, shining, translucent layer, at first of a grayish-yellow, but later becoming dirty "golden" color. There is a distinct tendency for the colonies making up this growth to remain isolated or to become only partly confluent, so that the shape of the growth is irregular and waved or notched at the edges. In our cultures the growth on agar-agar never attained any considerable magnitude.

Upon potato a yellowish-orange color is slowly produced at the temperature of the room, the growth being devoid of special peculiarities.

In milk coagulation is produced and lactic and butyric acids are formed, so that litmus if added is reddened.

Sternberg states that cultures may be kept for a year if frequently transplanted, but in our experience this is accomplished with difficulty. Our cultures died out after about three months, and could not be revived by temperature or specially adapted culture media.

The morphology of the organism is not characteristic. The individuals are spherical, from 0.7 to 0.9  $\mu$  in diameter, very seldom occurring isolated, but generally in pairs or irregular groups. When examined under very high powers under the best conditions of staining, the organism is seen to consist of two hemispheres separated from each other by a narrow intervening space.

It stains with great avidity, and retains the stain, when colored by Gram's method, perhaps better than any other organism.

Felser found this organism in every normal conjunctival sac which he examined.<sup>1</sup>

Shongolowicz found this organism nine times. It was also found by Kucharski, Leber, Bernheim, Marthen, and Fick.

*Staphylococcus Pyogenes Albus* (Rosenbach).—This micro-organism is identical with the preceding, except that it is colorless in its growth and is somewhat less pathogenic. Surface cultures on agar-agar or potato have a milk-white color.

Shongolowicz found this organism twelve times.

*Staphylococcus Epidermidis Albus* (Welch) is probably identical with the preceding species, or is an attenuated form of the same. It seems to be universal in its distribution upon the surface of the body. In its growth it

---

<sup>1</sup> See "Zur Frage der Mikroorganismen der Antiseptik des Conjunctivalsackes," Vrach, 1889, p. 850.

liquefies gelatin a little more slowly than the staphylococcus pyogenes albus, does not coagulate milk, and when injected into rabbits is far less virulent.

*Staphylococcus Pyogenes Citreus* (Passet).—This form of staphylococcus is much less pathogenic than its predecessors, and seems to be called pyogenes rather because of its association with the others than because of any distinct pyogenic properties possessed by itself. It is not infrequently found where staphylococcus pyogenes aureus and albus are present, and its vegetation characters differ principally in the formation of a brilliant lemon-yellow color, instead of the orange-golden of the one and the white of the other. As is true of the others, this pigment is formed only in the presence of oxygen. The liquefaction of the gelatin is slow.

*Streptococcus Pyogenes* (Fehleisen).—So far as the results of our own work and an examination of the literature are concerned, we have not been able to determine that this very virulent organism occurs in the conjunctival area except in cases of true diphtheritic inflammation, when it is a constant associate of the Klebs-Löffler bacillus, and in facial erysipelas spreading to the eye. It may be that under these circumstances there are two distinct forms which occur, that in diphtheria being the streptococcus pyogenes, that in erysipelas the streptococcus erysipelatos. This is the view held by Von Lingelsheim, who differentiates the two forms by their difference in pathogenesis, the streptococcus erysipelatos being pathogenic for mice, while the streptococcus pyogenes is not. There is nothing in the morphology of the individuals or in their vegetation which will enable them to be differentiated.

Under the microscope the streptococcus pyogenes appears as a small spherical individual from 0.4 to 1  $\mu$  in diameter, the individuals being arranged in chains, varying in length according to the culture material upon which they were grown. Sometimes, instead of these chains, no form except diplococci can be found. Isolated individuals are rare. Sometimes only chains are formed, which may consist of from four to twenty individuals. When seen in sections, or in cover-glass preparations from the conjunctiva, or from the serum of an erysipelatos patch, the organisms appear to lie more frequently between than within the cells, and are most numerous in the lymph-spaces.

The vegetative properties of this individual are good. It grows not only at the temperature of the body, but also at the temperature of the room, upon almost all culture media.

When a drop of secretion containing this organism is mixed with melted gelatin and "plated," the colonies which appear are very small and translucent. The superficial colonies spread out to form a transparent disk about .0005  $\mu$  in diameter. The colonies appear slightly granular when examined with the microscope, and are slightly yellowish in color. Later they become darker and less transparent, and irregular masses consisting of chains of organisms project from the edges.

In gelatin punctures the colonies spring up along the whole length of the puncture as small, spherical, translucent, whitish colonies, which are

closely crowded together at the upper portion of the line of growth, and often distinctly separated from each other below. There is no growth on the surface, or a small collection of amalgamated colonies may be present. The gelatin is not liquefied.

On agar-agar and blood-serum the growth is similar to that on gelatin. It does not seem to grow on potato.

Milk is coagulated by the growth of this coccus, and a slight acidity results.

This organism was found in cases of catarrhal conjunctivitis by Kucharski.

Parinaud<sup>1</sup> says that microscopical examination of cases of conjunctivitis made by Morax showed the presence of streptococci.

*The Micro-Organism of Trachoma.*—The question of specificity in trachoma is indeed a weighty one. Perhaps no conjunctival lesion has been subjected to more investigation with less accurate result than this. While at one time all observers were well satisfied that there was a "trachoma-coccus," the lapse of time and the weight of counter-evidence have sufficed to make very questionable the specific nature of the various described organisms.

The subject of mycology in trachoma is one very difficult to approach in a paper of this kind, because we do not consider diseases, but microorganisms. As, however, so many different organisms must be separately described, each headed the "trachoma-coccus" or the "trachoma-bacillus," it has seemed better to treat the whole subject as one, and, while endeavoring to point out the errors into which the various experimenters have fallen, to describe such bacteria as are sufficiently characterized by them. As seems universal in work upon special subjects by men who are not bacteriologists, a multiplicity of organisms have arisen from inaccuracy and insufficiency of description, which simply bewilder the reader, who becomes more and more confused as each writer not only summarizes the work done by his predecessors, but concludes by adding a new one of his own.

The first bacteriological "*arbeit*" upon trachoma seems to have been done by Sattler,<sup>2</sup> who found small cocci of biscuit shape, joined in pairs, but separated from each other by an intervening space, and in size and appearance much resembling the micrococcus gonorrhœæ. Sometimes the organisms formed groups of three or four. They never touched each other, being always separated from their neighbors by a clear gelatinous surrounding zone. In the living state they were seen to be in continual movement.

This organism, when cultivated, grows very slowly upon nutrient gelatin at the room temperature, producing no liquefaction. Upon the surface a grayish-white, glistening layer is formed, which later assumes a yellowish color and tulip-shaped margins.

<sup>1</sup> Ann. d'Ocul., Paris, 1892, cvii. 88-92.

<sup>2</sup> Bericht über die XII. Versammlung der Ophthalmol. Gesellschaft, 1881.

Spherical colonies are formed along the line of puncture, arranged in a linear series like a chaplet. In blood-serum it grows along the line of puncture as a white, band-like stripe, which subsequently spreads out in the form of white clouds. The growth is more rapid at the temperature of the body than at that of the room. Upon potato the growth is very scanty. When touched with the platinum wire the cultures are viscid, drawing out into long threads. The organism does not grow in the absence of oxygen. It is not pathogenic for animals. This organism described by Sattler, though it resembles the gonococcus, is certainly a different organism. Baumgarten and also Kartulis have taken exception to its specific action, by showing that it is absent in many cases of ordinary trachoma and in cases of the virulent ophthalmia of Egypt.

While in Egypt, in 1882-83, Koch paid some attention to the ophthalmia prevalent there, and in his "Bericht der deutschen Cholera Commission in Aegypten und Suez"<sup>1</sup> he reports that his cultivation experiments from the conjunctivæ of these cases discovered the presence of the gonococcus and a tiny bacillus.

Michel<sup>2</sup> found in numerous cases of Egyptian catarrh a diplococcus much resembling the gonococcus, but smaller. It stained well by the usual methods, as also by Gram's method. In studying sections of the eyelids he was able to find the cocci in the contents of the follicles only, never in the epithelial cells.

When secured in pure culture, these cocci formed upon the surface of blood-serum or agar-agar a grayish-white thread-like skin. By and by this changed to a regular stripe, turning yellowish as it grew older.

Upon gelatin there was a whitish surface-growth with slow liquefaction, which allowed the gelatin to shrink up into a tulip shape. When the growth was sufficiently advanced for this, it also became yellowish in color. Michel affirmed that, while cultures and direct inoculations into animals were fruitless in producing the disease, inoculations into the human eye produced granules containing the cocci.

While both of these observers were in accord as to the shape and size of the organisms found by them, the former alone mentions the transparent encapsulating substance which was so characteristic of his, while the latter alone was successful in his inoculations.

Schmidt<sup>3</sup> differed again, and continually found in the secretions small, perfectly round, isolated cocci, without a dividing septum, surrounded by a clear gelatinous area, and resembling the staphylococcus pyogenes aureus. They occurred free and also in the protoplasm of the epithelial cells. In this connection let us point out that the morphology of the staphylococcus pyogenes aureus is now well known to be exactly that

<sup>1</sup> See Wiener Med. Woehenschrift, 1883, p. 1550.

<sup>2</sup> See Archiv f. Augenheilk., Bd. xvi., 1886.

<sup>3</sup> Dissert. St. Petersburg, 1887, Ueber die Mikroorganismen bei den Trachom und einigen anderen mykotischen Krankheiten der Bindehaut des Auges.

which Schmidt rejects. His assertion that in these organisms there was no dividing septum exactly contradicts his subsequent statement that they were like the staphylococcus pyogenes aureus. It is also well to note that Pinto<sup>1</sup> could not find any bacteria in sections of the conjunctiva which he studied; Michel found them only in the follicular contents, never in the epithelium; while Schmidt found them free as well as in the epithelial cells.

Schmidt's coccus, which he seems to regard as identical with that of Sattler, and as the cause of trachoma, is characterized by its size, its slight motility, the gradual liquefaction and tough consistence of the gelatin, and the occurrence of gray or milk-white spots on blood-serum or agar-agar. The liquefaction of the gelatin comes on late. The development of the organism is more rapid at the body temperature than at the room temperature.

Schmidt found that the organisms which he observed readily induced trachoma in birds, which were very susceptible, but that mammals contracted the disease only after numerous repeated inoculations.

Schmidt's studies were thorough, comprising sixty-three cases, in forty-nine of which this coccus was found.

Even if we conclude that Schmidt's observations upon the morphology of his coccus were inaccurate, and that it was of the characteristic biscuit form, other characters will exclude it from the same class as its predecessors.

Kueharski<sup>2</sup> investigated twenty-six cases of trachoma and found numerous bacteria, among which were staphylococcus pyogenes aureus, bacillus subtilis, bacillus mesentericus vulgatus. When these accidental organisms were excluded, his cultures all showed one characteristic organism. This organism was a diplococcus of the size and shape of the gonococcus, possessed of a "springing movement." Sometimes it was seen to occur singly, sometimes in groups; sometimes short chains were formed, sometimes a figure 8. They possessed a strong affinity for the aniline dyes.

When inoculated upon the surface of agar-agar, very small grayish spots were seen to develop in twenty-four hours. These increased in size as time passed on, took on a shining white color, and coalesced to form a thick white film. The agar punctures showed narrow grayish-white streaks. In the water of condensation there was visible a slight cloudiness, and at the bottom of the liquid a whitish sediment was visible. If the culture be kept for two or three months it becomes grayish or slightly yellowish. In four months the growth ceases, and cannot be revived by inoculation.

In gelatin punctures a depression occurs on the surface, and along the path of the needle numerous little stripes can be seen without a lens.

In six or seven days a distinct whitish membrane can be seen upon the surface, which increases until nearly the whole surface is included. This

---

<sup>1</sup> Centralb. f. Prakt. Augenheilk., 1884, p. 97.

<sup>2</sup> Bakteriologisches über Trachom, Centralb. f. Prakt. Augenheilkunde, 1887, xi. p. 225.



is followed by depression. At the same time the growth occurs in the puncture as grayish spots. The gelatin liquefies very slowly, in the form of a goblet. In four weeks the whole of the gelatin is liquefied, appearing as a cloudy mass. This organism differs from the organisms previously described by this goblet-shaped liquefaction of the gelatin, which progresses until complete.

Upon blood-serum the growth appears first as white colonies, which subsequently flow together to form a pellicle.

On potato the growth is slow, and occurs as white spots.

In bouillon the growth is rapid, and causes turbidity of the medium, with considerable precipitation.

The colonies are simple whitish, shining drops, characterized by permanent solidity of the gelatin.

The organism is devoid of pathogenic properties.

The work of Kucharski was executed with a care which that of his predecessors lacked. The description of his coccus is thorough and excellent. Unfortunately, while it did not seem specific, he concluded to add it to the literature of trachoma.

Goldschmidt's<sup>1</sup> coccus corresponds very closely to that of Michel, forming the tulip-like growth in gelatin, and not causing liquefaction of that medium.

Very remarkable results were attained by Washejewski,<sup>2</sup> who studied thirty cases of trachoma in its various stages. He found single cocci and groups of cocci enclosed in the lymphoid cells, the *red blood-corpuscles*, and the epithelial cells. He was unable to find any other organisms. At this point we must remark that, while most observers find cocci much more frequently than bacilli on the conjunctival surface, bacilli are present sometimes in considerable numbers. To confirm this statement, see the long list of bacilli which this paper contains.

The cocci thus found enclosed in the cells resembled the gonococcus, but were successfully cultivated upon gelatin. Thirty-six hours after gelatin was inoculated a whitish streak occupied its surface and continued to increase in size for four days and became grayish in color. The gelatin softened, but did not liquefy. In four weeks the color became slightly yellow, this color being most pronounced on agar-agar. All attempts to produce trachoma by inoculating animals with this organism failed.

Exactly what Washejewski did see cannot be made out from this description, nor can we tell whether or not it was one of the organisms previously described. At all events, it is not specific for trachoma.

Staderini<sup>3</sup> found a coccus much like the cocci already described. Its morphology was very similar to that of the gonococcus; it grew—with

<sup>1</sup> Zur Actiologie des Trachoms, Centralb. f. Klin. Med., 1887, No. 18.

<sup>2</sup> Zur Actiologie und Therapie des Trachoms, Wojenno-med. Shurnal, 1887, October.

<sup>3</sup> Ricerche sulla istologia e sulla patogenesi della conjunctivite trachomatosa, Annali di Ottalmologia, 1888.

the production first of a grayish, then a yellowish layer—on agar-agar and liquefied gelatin. Baumgarten investigated this organism, and could not see that it differed from the *staphylococcus pyogenes aureus*.

Wittram<sup>1</sup> endeavored to convert the chaos into order. After the study of thirty-nine cases of trachoma, and the discovery of cocci similar to those of previous authors, he succeeded in separating the reported organisms into—

1. A milk-white coccus which did not liquefy gelatin.
2. A milk-white coccus which did liquefy gelatin sooner or later.
3. An orange-yellow, non-liquefying coccus.
4. A yellow coccus which liquefied in two days.

As far as he could determine, inoculation experiments were all negative in their results.

Shongolowicz<sup>2</sup> introduced an interesting innovation in the etiology of trachoma by describing a specific bacillus which he found in seven out of numerous cases which he studied. His work, to which an excellent literary review is attached, seems to have been carefully done, and the description of his bacillus is very complete.

The bacillus is characterized by its exceedingly slow growth. Shongolowicz took note of this in securing it in pure culture, which was done by spreading material from the follicles upon the surface of culture media and allowing the tubes to stand for ten days. If at the expiration of this time the tubes continued sterile, new tubes were inoculated from the material in the first, and stood in the thermostat at 37° C. Sometimes no growth could be made out, even with a lens, for four weeks. When this slow and delicate growth appeared, it could be noted only as a slight discoloration upon the surface of the agar-agar and a small grayish or yellowish-gray precipitate in the water of condensation.

Upon blood-serum it was possible to discover it only after the lapse of three months, when grayish-white colonies gave its surface a slight change of color.

In gelatin the growth varied according to the percentage of gelatin used. In five-per-cent. gelatin it appeared along the puncture at the room temperature in forty-eight hours. Single delicate white spots, scarcely perceptible to the lens, are first found. These gradually increase in height and breadth, and in eight or ten days reach a diameter of five millimetres, and have a white color with a yellowish tinge, irregular borders, and granular surface. Beneath the growth the gelatin is absorbed and a hemispherical deepening occurs. The gelatin, however, *never liquefies*. The culture grows very slowly along the line of inoculation, and even after a month the individual, spherical, grayish-white colonies are scarcely visible to the naked eye.

<sup>1</sup> Bakteriologische Beiträge zur Aetiologie des Trachoms, Diss., Dorpat, 1889.

<sup>2</sup> St. Petersburger Med. Wochenschrift, 1890, N. F., Bd. 7, p. 247, Zur Frage von dem Mikroorganismus des Trachoms.

In ten-per-cent. gelatin the growth is also very slow. Along the stroke a granular, translucent streak forms. The growth is elevated above the surface, but appears depressed, because of the absorption of the gelatin beneath it.

On the surface of agar-agar, in two or three days, isolated, small, shining, delicate plates are formed. These appear whitish by transmitted light, and grayish with a greenish-yellow tinge by reflected light. In the course of development, nearly the whole surface is covered with a thin layer of the culture of the same color, having on the periphery single dot-like plates. Along the stroke a thick layer of the culture with a distinctly greenish-yellow color forms. The whole surface takes on a mother-of-pearl appearance.

The masses formed upon agar-agar are difficult to remove with the platinum wire. If the surface of the agar-agar is dry, the culture does not spread as described above, but occurs only along the stroke.

In bouillon the growth is slow. No judgment of it can be formed in less than two weeks.

On potato the growth is very scanty, and possesses much the same characters as the agar-agar cultures.

The growth of the culture is as rapid at the room temperature as in the thermostat. When the oxygen is removed the bacillus will not grow.

In the hanging drop the bacilli are found to possess a rapid locomotive power. They are not infrequently united at their ends, and sometimes lie parallel to each other. They never form chains. A characteristic peculiarity is a condensation of protoplasm at the ends, which makes the organisms appear more distinctly refracting at this point than elsewhere. The ends are rounded.

The organism stains in a rather characteristic manner, the condensed ends appropriating more of the stain than the rest of the protoplasm. It stains well by Gram's method.

Careful measurements show the length of the bacillus to vary from 0.75 to 2.0  $\mu$ , with a breadth varying from 0.3 to 0.5  $\mu$ .

Inoculation of pure cultures of this bacillus under the skin of two white mice, one guinea-pig, and one rabbit gave no results.

Sixteen inoculations of pure cultures of the bacillus upon the conjunctivæ of five rabbits, two dogs, four pigeons, one guinea-pig, two white mice, and two cats were all productive, not of trachoma, but of a somewhat similar disease. Shongolowicz concludes from this that his results were better than those of previous writers.

Our review of this subject may as well end here. We have shown that a variety of different organisms have been described as specific of trachoma, but we have also shown that none of them have stood the severe tests of specificity laid down by Koch.

Some of the described organisms seem to be true gonococci; some are

undoubtedly the staphylococci pyogenes aureus and albus. The bacilli are probably accidental contaminating organisms.

At the present moment we have no reason for regarding any bacteria as specific for trachoma. There seems, however, to be a pretty well established connection between trachoma and gonorrhœa, and it is not improbable that the rôle played by the gonococcus is of more importance in the etiology of trachoma than is generally supposed.

Our own experiments not having extended into trachoma very deeply, and having revealed a variety of organisms—among them the bacillus violaceus fuscus—in such cases as were studied, we do not feel able to speak authoritatively upon so important a subject, but refer the reader to the thorough treatises to be found in this and other works.



## INDEX TO VOLUME II.

---

### A.

- Abduction, 179, 180.
- Aberration, appearance of light area in, in skiascopy, 97.  
 application of concave mirror in skiascopy to, 106.
- Ablatio retinae, visual field in, 224.
- Abortive attacks, prodromal, of glaucoma, visual field in, 229.
- Absolute central scotoma, 198.  
 heterophoria, 181.
- Accidents due to color-blindness, 328.
- Accommodation, refraction, and glasses, effect of, on acuity of vision, 17.
- Achloropsia, 319.
- Achromatopsia, 317.
- Aconitine, extract of, as a myotic, 46.
- Acquired color-blindness, 323.
- Action of atropine, 32, 33, 34, 35, 36, 37.  
 with cocaine, 33.  
 of cocaine as a mydriatic, 39, 40.  
 of daturine, 37.  
 of duboisine, 37, 38.  
 of ephedrin, 39.  
 with homatropine, 39.  
 of eserine, 45.  
 of gelseminine, 39.  
 of hyoscine, 38.  
 hydrochlorate, 38.  
 of hyoscyamine, 38.  
 of muscarine, 46.  
 of mydrin, 39.  
 of myotics in corneal ulcers, 45.  
 in glaucoma, 44.  
 in irregular astigmatism, 45.  
 of pilocarpine, 45.  
 of scopolamine, 38.
- Acuity, central visual, 191.  
 relation of, in temporary hemianopsia, 275.  
 of vision for form, 197.  
 for points, 197.  
 on the methods of determining the, Herman Snellen, M.D., 11.  
 visual, effect of refraction, accommodation, and glasses on, 17.  
 influence of illumination on, 17.  
 of transparency of media on, 17.
- Adduction, 179, 180.
- Advantages, relative, of the plane and the concave mirror in skiascopy, 106, 107.
- Age, effect of, on vision, 21.  
 relation of, to blindness, 428.
- Aglaukopsia, 319.
- Air, micro-organisms in the, 465.
- Akyanopsia, 318.
- Albinism as a cause of congenital blindness, 439.
- Albino, fundus of the, 85.
- Albrand's test-types, 26.
- Albuminuric retinitis, diagnosis of, from opaque nerve-fibres, 84.  
 visual field in, 218, 219, 220.
- Alcohol, absolute, in antisepsis, 472.  
 amblyopia, visual field in, 260.  
 poisoning a cause of blindness, 458.
- Alexia, 301.
- Alternating strabismus, 173.
- Amblyopia, alcohol, visual field in, 260.  
 congenital, as a cause of congenital blindness, 439.  
 tobacco, visual field in, 260.  
 toxic, visual field in, 249, 252.
- Amnesic color-blindness, 301.
- Anatomy of the optic nerves, 240.
- Andrews on antisepsis, 463.
- Andrews's portable sterilizer, 487.
- Anerythroptosis, 319.
- Aneurism, temporal hemianopsia in, 277.
- Angle of deviation system, 150.  
 refracting, of a prism, 141.  
 determination of, 158.  
 visual, the, 13, 22, 169.
- Aniridia as a cause of congenital blindness, 439.
- Anisometropia, distortion of skull in, 362.
- Anophoria, 171, 173.
- Anotropia, 171, 173, 184, 185.
- Anterior chamber, detection of foreign bodies in the, 81.  
 detection of opacities of the, 81.  
 polar cataract, detection of, 81.  
 surface of the cornea, ophthalmometry of different parts of the, 129.
- Anthrax bacillus, 464.
- Antisepsis and disinfectants, 468.  
 experience of ophthalmic surgeons relative to the value of, 473.  
 importance of, 463.  
 J. A. Andrews on, 463.  
 of the conjunctival sac, 475.  
 aqua chlorata in, 476.  
 bichloride of mercury in, 475, 476.  
 boric acid in, 475.  
 sodium chloride in, 476.
- Apex of a prism, 141.
- Apparatus for skiascopy, 108.
- Apparent movement of light in the pupil in skiascopy, 93.
- Appearance of light area in aberration in skiascopy, 97.
- Architecture of school-buildings, 382.
- Area, light, appearance of, in aberration, in skiascopy, 97.  
 form of, in skiascopy, in irregular astigmatism, 98.  
 in regular astigmatism, 95, 96.  
 in the pupil in skiascopy, form of, in hyperopia and myopia, 95.  
 of the face in skiascopy, 92.  
 retinal light, in skiascopy, 92.
- Arecoline, action of, as a myotic, 46.
- Arlt's orthoscope, 71.
- Arrangement of light in skiascopy, best, 94.
- Artery, central, of the retina, 86.
- Artificial astigmatic cornea in the ophthalmometer, 119.

- Artificial illumination in school-buildings, 395.  
 Association fibres, 284.  
 Asthenopic eyes, results of optical correction of, in arresting myopia, 374.  
 Astigmatic cornea, artificial, in the ophthalmometer, 119.  
 Astigmatism, corneal, diagrammatic representation of, 132, 133, 134.  
 distortion of skull in, 362.  
 empirical formula indicating the total, 124, 125, 126.  
 irregular, action of myotics in, 45.  
 application of concave mirror in skiascopy to, 106.  
 of plane mirror in skiascopy to, 103.  
 form of light area in skiascopy in, 98.  
 regular, application of concave mirror in skiascopy to, 105.  
 of plane mirror in skiascopy to, 102.  
 form of light area in skiascopy in, 95, 96.  
 Atrophy, descending, of the optic tract, visual field in, 245.  
 idiopathic, of the optic nerve a cause of blindness, 447.  
 optic, partial, 238.  
 simple true, prognosis of, 239, 240.  
 visual field in, 235.  
 progressive, of the optic nerves, mercury in, 246.  
 visual field in, 259.  
 Atropine, action of, 32, 33, 34, 35, 36, 37.  
 with cocaine, 33.  
 history of, 32.  
 ill effects of, 36.  
 treatment of, 36.  
 morphine in, 36.  
 pilocarpine in, 36.  
 in glaucoma, 36, 37.  
 use of, 80.  
 Atropinism, 36.  
 prevention of, 36.  
 boric acid in, 36.  
 nitro-atropine in, 36.  
 salicylate of atropine in, 36.  
 Attacks, prodromal abortive, of glaucoma, visual field in, 229.  
 Aubert's binocular corneal microscope, 60, 61.  
 Austria, blindness in, 425.  
 Auto-infection, 467.  
 Auto-ophthalmoscopes, 72.  
 Axanthopsia, 318.  
 Axial neuritis, visual field in, 251.  
 Axis, visual, the, 189.
- B.**
- Bacillus, anthrax, 464, 469.  
 capsule, of Loeb, 494.  
 circumscriptus, 494.  
 cœrulefaciens, 492.  
 coli communis, 495.  
 diphtheriæ, 469, 497.  
 of Fick, 526.  
 fluorescens liquefaciens, 500.  
 hirsutus, 501.  
 influenzæ, 504.  
 lepræ, 507.  
 mallei, 507.  
 megatherium, 510.  
 mesentericus fuscus, 513.  
 ruber, 514.  
 vulgaris, 511.  
 mycoides, 514.  
 of anthrax, 469.  
 Bacillus of Colomiatti, 494.  
 of Fick, 500.  
 of glanders, 469.  
 of measles, 514.  
 of pink-eye, 516.  
 of tetanus, 469.  
 of tuberculosis, 469, 523.  
 pneumococcus, Friedländer's, 464.  
 pneumoniae, Friedländer's, 518.  
 prodigiosus, 516.  
 pyocyaneus, 519.  
 septicus keratomalaciæ, 521.  
 subtilis, 520.  
 sucinacius, 521.  
 syphilis, 522.  
 varicosus conjunctivæ, 524.  
 violaceus flavus, 525.  
 Bacteria, pathogenic, ways by which they may reach a wound, 465.  
 which do not form spores, 469.  
 spore-bearing, which excite wound-infection, 469.  
 Badal's colored cylinders, 343.  
 Balance of the extra-ocular muscles, 167.  
 Ballottement, ocular, 80.  
 Basal gummatous neuritis, visual field in, 269.  
 Base-apex line of a prism, 141.  
 determination of, 158.  
 Bechterew's fibres, 284.  
 Bed-perimeter, Wilbrand's, 210.  
 Bernheimer's fibres, 285.  
 Berry, George A., translator of article by Herman Snellen, 11.  
 Best arrangement of light in skiascopy, 94.  
 Bichloride of mercury in antiseptics, 470.  
 Binocular corneal loupe, 49.  
 microscope, Aubert's, 60, 61.  
 diplopia, 168, 169.  
 field of vision, the, 192, 211.  
 in convergent strabismus, 212.  
 in divergent strabismus, 213.  
 in monocular squint, 213.  
 Mariotte's spot in, 212.  
 loupe, Saemisch's, 58.  
 Westien's, 58.  
 Bisulphide of carbon poisoning a cause of blindness, 458.  
 Blackboard, graduated, the use of, to determine the field of vision, 193.  
 Blackboards in schools, 407, 408.  
 Blepharitis as a cause of congenital blindness, 440.  
 Blind, ages of the, 421, 422.  
 of the congenitally, 421.  
 spot, 200.  
 in congenital coloboma, 201.  
 the, in Austria, 425.  
 in Denmark, 425.  
 in England and Wales, 422.  
 in Finland, 425.  
 in France, 424.  
 in the German Empire, 425.  
 in Great Britain, 422.  
 in Holland, 425.  
 in Hungary, 425.  
 in Ireland, 424.  
 in Italy, 425.  
 in Russia, 426.  
 in Scotland, 423.  
 in Sweden, 425.  
 in the United States, 420, 421, 422.  
 Blindness, acute blennorrhœa of adults in, 444.  
 congenital, causes of, 439.  
 definition of, 419.  
 diminution of, 461, 462.  
 statistics of, 462.  
 due to idiopathic diseases of the eye, 442.

- Blindness, etiology of, 132.  
 alcohol in, 458.  
 bisulphide of carbon in, 458.  
 cerebro-spinal meningitis in, 456.  
 childhood in, 457.  
 lactation in, 457.  
 lead poisoning in, 458.  
 mercurial poisoning in, 458.  
 myopia in, 459.  
 ophthalmia neonatorum in, 442.  
   statistics of, 442.  
 pregnancy in, 457.  
 serofula in, 458.  
 snake-bite in, 459.  
 syphilis in, 457.  
 tobacco in, 458.  
 its frequency, causes, and prevention, I. M. Hays, 419.  
 prevention of, 460.  
 relation of age to, 428.  
   of climate to, 426.  
     Zeune's law of, 427.  
   of sex to, 429.  
 statistics of, 419.
- Blood, germicidal power of, 465.  
 Boettcher's test-types, 24.  
 Bogrow's fibres, 284.  
 Boiling water in antiseptics, 473.  
 Books in schools, 409.  
 Boric acid, eserine with, 45.  
   in antiseptics, 472.  
   in prevention of atropinism, 36.
- Brain, diseases of the, a cause of blindness, 451.  
 Bruecke's loupe, 57, 58.  
 Burchardt's test-types, 24, 25.
- C.**
- Calabar bean, 40.  
 Calcarine fissure, 284, 296, 298, 299.  
 Capsule bacillus of Loeb, 494.  
 Carbolic acid in antiseptics, 470, 471.  
 Carter's test for color-sense, 345.  
 Cataract, anterior polar, detection of, 81.  
   congenital, as a cause of congenital blindness, 439.  
   detection of, early, 80.  
   in schools, 360.  
   operations, ophthalmometry after, 122, 123.
- Causes of blindness, 431.  
   Magnus's table of, 433.  
   Oppenheimer's table of, 437.  
   Trousseau's table of, 434.  
   of congenital blindness, 439.
- Centrad, 149.  
 system, 150.
- Central artery of the retina, 86.  
   visual field in embolism of the, 220, 221.  
 color-scotoma, test for, 348.  
 relapsing syphilitic retinitis, visual field in, 220.  
 scotoma, 197.  
   absolute, 197, 198.  
   indistinct, 197.  
   negative, 198.  
   of fatigue, 199.  
   positive, 198.  
   relative, 198.
- veins of the retina, 86.  
 pulsation of the, 86.
- visual acuity, 191.  
 relation of, in temporary hemianopsia, 275.  
 to the defects of the visual field in diseases of the optic nerve, 240.
- Centre, color-, 299.  
 geometrical, of a decentred lens, 151.  
 visual, 298.
- Centres, primary optic, hemianopsia in lesions of the, 294.
- Centrifugal visual fibres, 284.  
 Centripetal visual fibres, 284.
- Cerebral hemispheres, visual field in diseases affecting the optic fibres in the, 296.  
 tumors a cause of blindness, 451.
- Cerebro-spinal meningitis a cause of blindness, 456.
- Change of the colors of signals, 328.
- Chemical disinfectants, 469.
- Chiasm, blood-supply of the, 264.  
 experimental injuries of the, 263.  
 hemorrhage into the, temporary hemianopsia in, 277.  
 paracentral scotoma in diseases of the, 266.  
 paths of nerve-fibres in, 262.  
 temporal hemianopsia in diseases of the, 262, 266.  
 visual field in diseases affecting the, 262.
- Chibret, chromatophotometer of, 347, 351.  
 on antiseptics, 474.
- Childbed a cause of blindness, 457.
- Chlorine in antiseptics, 472.
- Chloroform in antiseptics, 472.
- Choked disk, 200.  
 visual field in, 231, 232, 233, 234.
- Chorioid and retina, visual field in diseases of the, 214.  
 and sclerotic, visual field in perforating wounds of the, 221, 222.  
 coloboma of the, 85.  
   as a cause of congenital blindness, 439.  
 inflammations of, in schools, 360.
- Chorioidal colobomata, 216.  
 visual field in, 216.  
 ring, 86.  
 tumors, lateral illumination in, 55.
- Chorioiditis disseminata, visual field in, 228.
- Chorioido-retinitis as a cause of congenital blindness, 441.  
 peripapillary, 200.
- Chromatophotometer of Chibret, 347.
- Cladotrix dichomata, 527.
- Classes of heterotropia, 183, 184, 185.
- Climate, relation of, to blindness, 426.  
 Zeune's law of, 427.
- Cocaine, action of, as a mydriatic, 39, 40.  
 atropine with, 33.
- Cocci of pus, 469.
- Coccius's ophthalmoscope, 68.  
 orthoscope, 7.
- Cohn's embroidery patterns, 343.  
 test-types, 26.
- Colliculus anterior, 284.
- Coloboma, chorioidal, 85, 216.  
 as a cause of congenital blindness, 439.  
 visual field in, 216.  
 congenital, blind spot in, 201.  
 extra-papillary, visual field in, 216.  
 of the iris as a cause of congenital blindness, 439.  
 retinal, 210.
- Colomiatti, bacillus of, 494.
- Color-blindness, accidents due to, 328.  
 required, 323.  
 amnesic, 301.  
 Chibret's instrument in testing for, 351.  
 congenital, relation of, to heredity and sex, 322.  
 statistics of, 325.  
 tests for, 330.  
 dangers of, 326.  
 partial, 317.

- Color-blindness, re-examination for, 352.  
 seat of, 326.  
 total, 316, 332.  
 -centre, 299.  
 -fields, 205.  
 -ignorance, 321.  
 -limits, relation of, 205, 206.  
   between white and, 206.  
 peripheral fields of, perimetric test of, 348.  
 phenomena, prismatic, 148.  
 -scotoma, test for central, 348.  
 -sense, Carter's test for, 345.  
   Donders's test for, 343.  
   Oliver's test for, 345.  
   reduced, 317.  
 -stick, Thomson's, 336.  
 -table, Daac's, 342.  
   Reuss's, 343.
- Colored cylinders, Badal's, 343.
- Colors, matching of, 321.  
 naming of, 330.  
 of signals, change of the, 328.
- Combined use of the ophthalmoscope and the magnifying glass, 56.
- Concave and plane mirrors in skiaseopy, relative advantages of, 106, 107.  
 mirror in lateral illumination, 49.  
 in skiaseopy, application of, 103.  
   to aberration, 106.  
   to emmetropia, 105.  
   to hyperopia, 104.  
   to irregular astigmatism, 106.  
   to myopia, 105.  
   to regular astigmatism, 105.
- Coneomitant squint, 172.
- Congenital amblyopia as a cause of congenital blindness, 439.  
 anomalies and hereditary predisposition in the form of the eyeball, 362.  
 blindness, causes of, 439.  
   albinism, 439.  
   aniridia, 439.  
   blepharitis, 440.  
   chorioido-retinitis, 441.  
   coloboma of the chorioid, 439.  
     of the iris, 439.  
   congenital amblyopia, 439.  
     cataract, 439.  
   consanguinity, 441.  
   heredity, 439, 440.  
   iritis, 441.  
   keratitis, 440.  
     interstitial, 441.  
   microphthalmia, 439.  
   nystagmus, 439.  
   persistence of pupillary membrane, 439.  
   phlyctenular conjunctivitis, 440.  
   retinitis pigmentosa, 439.  
   syphilis, 440.  
   tuberculosis, 440.
- cataract as a cause of congenital blindness, 439.  
 coloboma, blind spot in, 201.  
 color-blindness, relation of, to heredity and sex, 322.  
   statistics of, 325.  
 conus, visual field in, 217.  
 cupping of the disk, 84.
- Conjunctival diseases, lateral illumination in, 55.  
 sac of the healthy eye, micro-organisms of, 467.
- Connective tissues, diseases of, a cause of blindness, 452.
- Consanguinity as a cause of congenital blindness, 441.
- Constants of a prism, 151.
- Construction of school-buildings, 383.
- Contrasting images, induced, in heterophoria, 174.
- Contusions of the eye, visual field in, 223, 224, 225, 226.
- Conus, congenital, visual field in, 217.  
 enlarged, diagnosis of, from opaque nerve-fibres, 84.
- Convergence, power of, 182.
- Convergent strabismus, binocular field of vision in, 212.
- Corespace, the, 255.
- Cornea, artificial astigmatic, in the ophthalmometer, 119.  
 diseases of the, a cause of blindness, 446.  
 ophthalmometry of different parts of the anterior surface of the, 129.  
   of the posterior surface of the, 134, 135, 136, 137.  
 staphyloma of the, lateral illumination in, 55.
- Corneal astigmatism, diagrammatic representation of, 132, 133, 134.  
 leucomata, detection of, 81.  
 loupe, binocular, 49.  
 microscope, 49.  
   binocular, Aubert's, 60, 61.  
   de Wecker's, 60.  
   Gayet's, 60.  
   Liebreich's, 60.  
 ulcers, action of myotics in, 45.  
 detection of, 81.
- Cornu, descending, of the lateral ventricle, 297.
- Corpora quadrigemina, 296.
- Corpus geniculatum externum, 284, 294, 296.  
 lenticulare, 284.
- Correct and faulty sitting, principles of, 398.
- Corrosive sublimate, eserine with, 45.
- Cortical hemianopsia, 298.  
 retina, the, 299.
- Creosol in antiseptics, 472.
- Crété prismic mobile, 164.
- Cribriform field of vision, 203.
- Crossed bundle of the optic nerve, 241, 242.  
   dorsal portion of, 241, 242.  
   ventral portion of, 241, 242.  
   macular, dorsal portion of, 241.  
   ventral portion of, 241.
- Crystalline lens, ophthalmometry of the, 138, 139.
- Cuneus, 284, 298.
- Cupping of the disk, congenital, 84.
- Curriculum, modified, in schools, 379.
- Cutaneous system, diseases of, a cause of blindness, 452.
- Cyclitis a cause of blindness, 446.
- Cylinders, colored, Badal's, 343.
- Czermak's orthoscope, 71.

## D.

- Daac's color-table, 342.
- Dangers of color-blindness, 326.
- Darkschewitz's fibres, 285.
- Daturine, action of, 37.
- Decentred lens, geometrical centre of a, 151.
- Defects of field of vision, relation of, to the vertical meridian, 209.  
 of peripheral zone of visual field, varieties of, 209.  
 of vision in the schools, 353.  
 of visual field in diseases of the optic tract, 242.  
   groups of, 242.  
   relation of central visual acuteness to, in disease of the optic nerve, 240.  
 simulation of, 312.



- Defects of visual field, simulation of, Wilbrand's string apparatus in detection of, 313.  
 Definition of a prism, 141.  
 Dementia, visual field in, 259.  
 Denmark, blindness in, 425.  
 Dennett on prisms and prismometry, 141.  
 Descending atrophy of the optic tract, visual field in, 245.  
   cornu of the lateral ventricle, 297.  
   optic neuritis, visual field in, 248.  
   visual fibres, 284.  
 Desk and seat, school, 400.  
   minus distance of, 401.  
   of Chandler Adjustable Chair and Desk Company, 403.  
   of New York Hygienic School Furniture Company, 403.  
   school, hygienic, Smith's, 403.  
   Single Standard, 403.  
 Desks of school-buildings, 384.  
 Detachment of the retina a cause of blindness, 446.  
 Detection of anterior polar cataract, 81.  
   of color-blindness, W. Thomson and C. Weiland, 315.  
   of corneal leucomata, 81.  
   of early cataract, 80.  
   of foreign bodies in anterior chamber, 81.  
   of hypopyon, 81.  
   of occlusion of the pupil, 81.  
   of onyx, 81.  
   of opacities of anterior chamber, 81.  
   of synechiæ, 81.  
   of ulcers, 81.  
   of vitreous opacities, 80.  
 Determination of base-apex line of a prism, 158.  
   of reactions of the pupil, 81.  
   of refracting angle of a prism, 158.  
   of size of the pupil, 81.  
 Deviations in exclusion, 184.  
   through a prism, 141.  
   Snell's law of, 142.  
 De Wecker on antisepsis, 474.  
 De Wecker's corneal microscope, 60.  
   test-types, 27.  
 Diagrammatic representation of corneal astigmatism, 132, 133, 134.  
 Digestive system, diseases of the, a cause of blindness, 452.  
 Digitaline as a myotic, 46.  
   extract of, as a myotic, 46.  
 Diphtheritic conjunctivitis a cause of blindness, 446.  
 Diplococcus gonorrhœæ, 528.  
   lanceolatus pneumoniæ, 506.  
   pneumoniæ, 506.  
 Diplopia, binocular, 168.  
   in paralysis of the ocular muscles, general scheme of, 188.  
   induced, in heterophoria, 173.  
 Direct ophthalmoscopy, 78, 83.  
 Direction of light in school-buildings, 390.  
 Diseases of the chiasm, paracentral scotoma in, 266.  
   temporal hemianopsia in, 262, 266.  
   visual field in, 262.  
   of the optic nerve, etiology of, 234, 235.  
     inner retinal layers in, 215.  
     outer retinal layers in, 215.  
     papilla in, 215.  
   relation of central visual acuteness to defects of the visual field in, 240.  
   symptoms of, 215.  
   visual disturbances in, 234, 235.  
   field in, 234.
- Diseases of the optic tract, defects of the visual field in, 242.  
   groups of, 242.  
     hemianopsia due to, 289.  
   of the retina and chorioid, visual field in, 214.  
 Disinfectants and antiseptics, 468.  
   chemical, 469.  
 Disk, choked, 200.  
   visual fields in, 231, 232, 233, 234.  
   congenital cupping of the, 84.  
   optic, 85.  
 Disks, Rockoss's, 67, 70.  
 Disordered perception, zones of, 274.  
 Distortion of skull in anisometropia, 362.  
   in astigmatism, 362.  
 Disturbances, functional nervous, visual field in, 307.  
 Divergent strabismus, binocular field of vision in, 213.  
 Donders's pseudo-isochromatic wools, 343.  
   test for color-sense, 343.  
 Double prism, Maddox, 165.  
 Dressings, preparation of, 479.  
 Dry heat in antiseptics, 472.  
 Duboisine, action of, 37, 38.  
 Dyschromatopsia, 321.  
 Dysentery a cause of blindness, 452.
- E.**
- Edge of a prism, 141.  
 Edinger's fibres, 285.  
 Effect of refraction, accommodation, and glasses on acuity of vision, 17.  
 Effects of the reading habit, 381.  
 Elephantiasis, temporal hemianopsia in, 277.  
 Embolism of the central artery of the retina, visual field in, 220, 221.  
 Emerson's modification of Noyes's bar arrangement of rhomb-shaped prisms, 164.  
 Emmetropia, application of concave mirror in skiascopy to, 105.  
   of plane mirror in skiascopy to, 101, 102.  
   in schools, 354.  
 Empirical formula indicating the total astigmatism, 124, 125, 126.  
 England and Wales, blindness in, 422.  
 Enlarged conus, diagnosis of, from opaque nerve-fibres, 84.  
 Entozoa in the eye, lateral illumination in detection of, 53.  
 Entrance examination in schools, necessity for, 371.  
   requirements for, 372.  
 Ephedrin, action of, 39.  
   with homatropinc, action of, 39.  
 Epkens-Donders's ophthalmoscope, 70.  
 Epkens's ophthalmoscope, 68.  
 Erysipelas a cause of blindness, 452, 457.  
   streptococcus of, 466.  
 Eserine, action of, 45.  
   ill effects of, 45.  
   salicylate of, 45.  
   with boric acid, 45.  
   with corrosive sublimate, 45.  
 Esophoria, 171.  
   manifest, 174.  
   Stevens's photometer in determining, 175, 177.  
 Esotropia, 172, 183.  
 Examination, entrance, in schools, necessity for, 371.  
   requirements for, 372.  
   of eye by lateral illumination under pathological conditions, 52, 53, 54, 55.

- Examination of eyes in Philadelphia schools, 364.  
 methods pursued in, 364.  
 of normal eye by lateral illumination, 51, 52.  
 of paralyses of the ocular muscles, 187.  
 of spectacle lenses, 152, 153, 154, 155, 156.  
 of sphero-prism, 158.
- Examining the eye, methods of, 79.
- Exclusion, deviations in, 184.
- Exophoria, 171.  
 manifest, 175.  
 Stevens's phorometer in determining, 177.
- Exotropia, 172, 183.
- Experience of ophthalmic surgeons relative to the value of antisepsis, 473.
- Exposure of school buildings, 396.
- External capsule, 296.
- Extract of aconitine as a myotic, 46.
- Extra-ocular muscles, balance of the, 167.
- Extra-papillary colobomata, visual field in, 216.
- Eye, blindness due to idiopathic diseases of the, 442.  
 methods of examining the, 79.
- Eye-ball, congenital anomalies and hereditary predisposition in the form of the, 362.
- Eye-disease, influence of occupation on, 36.

## F.

- Face, light area of the, in skiaseopy, 92.
- Face-rest, Kallmann's, 416.
- Fantoseopie rétinienne, 109.
- Fasciculus longitudinalis inferior, 284.
- Fatigue, central scotoma of, 199.
- Fibres, Beehterew's, 284.  
 Bernheimer's, 285.  
 Bogrow's, 284.  
 Darksehewitz's, 285.  
 Edinger's, 285.  
 of the macula lutea, 295.  
 Perlia's, 285.  
 visual, association, 284.  
 centrifugal, 284.  
 centripetal, 284.  
 descending, 284.  
 reflex, 284.  
 von Gudden's, 285.  
 von Monakow's, 285.
- Fick, bacillus of, 500.  
 bacillus *d* of, 526.
- Field of regard, 169.  
 of vision, binocular, 211.  
 eribriform, 203.  
 effect of hypermetropia on the, 192.  
 of myopia on the, 192.  
 of width of pupil on the, 192.  
 in convergent strabismus, 212.  
 in diseases affecting the chiasm, 262.  
 in divergent strabismus, 213.  
 in functional nervous disturbances, 307.  
 in monocular squint, 213.  
 Mariotte's spot in the, 212.  
 methods of obtaining the, 192.  
 overshot, 265.  
 portions of the, 279, 280, 281.  
 relation of defects of the, to the vertical meridian, 209.  
 use of graduated blackboard to determine the, 191.  
 of the hand to determine the, 192.  
 of squares of paper to determine the, 192, 193.  
 of winking reflex to determine the, 192.
- Finland, blindness in, 425.
- Flower-paper, Heidelberg, 195, 205.
- Focal illumination, 47.

- Foreign bodies in the anterior chamber, detection of, 81.  
 lateral illumination in examining for, 52, 53.
- Form of light area in the pupil in skiaseopy, in hyperopia and myopia, 95.  
 in irregular astigmatism, 98.  
 in regular astigmatism, 95, 96.
- of the eyeball, hereditary predisposition and congenital anomalies in the, 362.  
 -sense, 323.
- Formula, empirical, indicating the total astigmatism, 124, 125, 126.  
 for the value of vision, 14.
- Förster's perimeter, 194, 195.
- Fovea centralis, the, 87.
- France, blindness in, 424.
- Friedenwald, Harry, translator of Laqueur's article, 47.
- Friedländer, bacillus pneumoniae of, 518.
- Frobelius's ophthalmoscope, 66.
- Frontal division of the visual paths, 284.
- Fuchs's test-types, 28.
- Functional nervous disturbances, visual field in, 307.
- Fundus in homonymous hemianopsia, 288.  
 of the albino, 85.
- Furniture, school, 397.

## G.

- Galezowski's test-types, 27.
- Gayet's corneal microscope, 60.
- Gelseminine, action of, 39.
- General disease a cause of blindness, 451.
- Geneva Optical Company's goniometer, 157, 158, 159.
- Geometrical centre of a decentred lens, 151.
- German Empire, blindness in the, 425.
- Germicidal power, determination of, 470.  
 of blood, 465.
- Glasses, accommodation and refraction, effect of, on acuity of vision, 17.  
 prismatic, measurement of, 155.
- Glaucoma a cause of blindness, 446.  
 action of myotics in, 44.  
 atropine in, 36, 37.  
 chorioiditis, causing hemeralopic fields, 207.  
 prodromal abortive attacks of, visual field in, 229.  
 simple, visual field in, 229, 230, 231.
- Goniometer, Geneva Optical Company's, 157, 158, 159.
- Gould on the ophthalmoscope and the art of ophthalmoscopy, 63.
- Graduated blackboard, use of, to determine the field of vision, 193.
- Granular ophthalmia a cause of blindness, 445.
- Great Britain, blindness in, 422.
- Green-blindness, 316, 319.  
 unioocular, 319.
- Groenouw, method of, in determining isopters, 197.
- Guillery's test-types, 25, 26.
- Gummatous neuritis, basal, visual field in, 269.  
 interstitial, visual field in, 258.

## H.

- Halo of the macula, 87.
- Hand, use of, to determine the field of vision, 192.
- Hartnaek's loupe, 57.
- Hawes's ophthalmoscope, 74.
- Hays on blindness, its frequency, causes, and prevention, 419.
- Healthy eye, micro-organisms of conjunctival sac of, 467, 468.

- Heat, dry, in antiseptis, 472.  
moist, in antiseptis, 473.
- Heidelberg flower-paper, 195, 205.
- Helmholtz's ophthalmoscope, 65, 66.
- Hemeralopia, perimetry in, 206.  
symptomatic, perimetry in, 207.
- Hemeralopic fields caused by chorioiditic glaucoma, 207.  
high-grade myopia, 207.  
senile eyes, 207.
- Hemianopsia, cortical, 298.  
due to disease of the tract, 289.  
homonyma duplex, 301.  
groups of, 303.  
homonymous, 285.  
diagnosis of, 282.  
fundus in, 288.  
in diseases of the optic conducting paths from the commencement of the tracts to the cortical centres of vision, 298.  
in lesions of the primary optic centres, 294.  
temporal, in aneurism, 273.  
in diseases of the chiasm, 262, 266.  
in elephantiasis, 277.  
in hemorrhages into the chiasm, 277.  
in hydrocephalus, 277.  
in multiple sclerosis, 277.  
in periostitis, 277.  
in syphilis, 277.  
in trauma, 277.  
in tubercle, 277.  
in tumors, 277.  
prognosis of, 276.  
relation of central visual acuteness in, 295.  
with Jacksonian epilepsy, 279.  
with monoplegia, 297.
- Hemianopsic scotoma, homonymous, 199.  
temporal, 199.
- Hemorrhages into the chiasm, 277.  
into the tract, 290.  
retinal, visual field in, 217, 218.
- Hereditary conditions, visual field in neuritis dependent on, 260.  
neuritis, visual field in, 252.  
predisposition and congenital anomalies in the form of the eyeball, 362.
- Heredity a cause of congenital blindness, 439, 440.
- Herschel combinations of prisms, 164.
- Heterophoria, 171, 173.  
absolute, 181.  
inducing contrasting images in, 174.  
diplopia in, 173.  
rod test for, 179.
- Heterotropia, 171, 172, 182.  
classes of, 183, 184, 185.  
parallax test for, 184.  
phorometer in testing for, 183.  
physiological, 183.  
tests for, 183.
- Historical notes concerning lateral illumination, 48.
- History of atropine, 32.  
of skiascopy, 108, 109.  
of the ophthalmoscope, 63, 64.
- Holland, blindness in, 424.
- Holmgren's lantern test, 343.  
wool test, 331.
- Homatropine, action of, 37.  
use of, 80.
- Homonymous hemianopsia, 285.  
diagnosis of, 282.  
fundus in, 288.  
hemianopsic scotoma, 199.
- Homonyms or lateral hemianopsia in diseases of the optic conducting paths from the commencement of the tracts to the cortical centres of vision, 278.
- Hungary, blindness in, 425.
- Hyaloid artery, persistence of the, 85.
- Hydrocephalus, temporal hemianopsia in, 277.
- Hydrogen peroxide in antiseptis, 472.
- Hygiene of the school-room, 379.
- Hygienic school-desk, Smith's, 403.
- Hyoscine, action of, 38.  
hydrochlorate, action of, 38.
- Hyoscyanine, action of, 38.
- Hyperesophoria, 172.  
left, 172.  
right, 172.
- Hyperexophoria, 172.  
left, 172.  
right, 172.
- Hypermetropia, effect of, on the field of vision, 192.  
in schools, 354.
- Hyperopia and myopia, application of concavo mirror in skiascopy to, 104.  
of plano mirror in skiascopy to, 99, 100, 101.  
form of light area on the pupil in skiascopy in, 95.
- Hyperphoria, left, 172.  
right, 172.  
Stevens's phorometer in determining, 177.
- Hypertropia, left, 172, 183.  
right, 172, 183.
- Hyphæma, lateral illumination in, 53.
- Hypopyon, detection of, 81.  
lateral illumination in, 53.

## I.

- Idiopathic atrophy of the optic nerve a cause of blindness, 447.  
diseases of the eye, blindness due to, 442.
- Ill effects of atropine, 36.  
treatment of, 36.  
morphine in, 36.  
pilocarpine in, 36.  
of eserine, 45.
- Illumination, focal, 47.  
influence of, on visual acuity, 17.  
lateral, L. Laqueur, 47.  
oblique, 47, 80.  
perpendicular, 48.
- Image, ophthalmoscopic, reversal of, 89.  
retinal, the, 11.
- Immediate source of light in skiascopy, 92.
- Indirect ophthalmoscopy, 78, 79, 82.
- Indistinct central scotoma, 198.
- Induced contrasting images in heterophoria, 174.  
diplopia in heterophoria, 173.
- Infection of wounds from skin of patient and operator, 467.  
spore-bearing bacteria which excite, 469.
- Inflammation of the optic nerve, visual field in, 234, 235.
- Influence of illumination on visual acuity, 17.  
of occupation on eye-disease, 459.  
of transparency of media on visual acuity, 17.
- Injuries by blows a cause of blindness, 450.  
by explosive substances a cause of blindness, 450.  
by foreign bodies a cause of blindness, 449.  
by pricks a cause of blindness, 450.  
by thrusts a cause of blindness, 450.  
received in war a cause of blindness, 450.  
to the skull a cause of blindness, 450.

- Insular sclerosis a cause of blindness, 452.  
 scotoma, 203.  
 Intermediate zone, 201.  
 Internal capsule, 284.  
 Interstitial gummatus neuritis, visual field in, 258.  
 Iodine in antiseptic, 472.  
 Iodol in antiseptic, 472.  
 Ireland, blindness in, 424.  
 Irido-eyelitis a cause of blindness, 446.  
 Iris, atrophy of the, lateral illumination in, 53.  
 coloboma of the, a cause of congenital blindness, 439.  
 injuries of the, lateral illumination in, 53.  
 neoplasms of the, lateral illumination in, 53.  
 reactions of the, determination of, 81.  
 Iritis a cause of blindness, 446.  
 a cause of congenital blindness, 441.  
 serosa, lateral illumination in, 52, 53.  
 Irregular astigmatism, action of myotics in, 45.  
 application of concave mirror in skiascopy to, 106.  
 of plane mirror in skiascopy to, 103.  
 Isopters, 196.  
 method of Groenouw in determining, 197.  
 test-letters of Snellen in determining, 197.  
 Italy, blindness in, 425.

## J.

- Jackson on skiascopy (the shadow-test) and its practical application, 89.  
 Jacksonian epilepsy, hemianopsia with, 297.  
 Jackson's prisme mobile, 165.  
 Jaeger's test-types, 28.  
 Javal on ophthalmometry and its clinical applications, 111.  
 Jcaffreson's test-disk, 342.

## K.

- Kallmann's face-rest, 416.  
 Katoporia, 171, 173.  
 Katotropia, 171, 184, 185.  
 Keratitis a cause of congenital blindness, 440.  
 interstitial, 441.  
 lateral illumination in, 52.  
 punctata vera, lateral illumination in, 52.  
 scrofulous vascular, lateral illumination in, 52.  
 Kératoscopie, 109.  
 Keratascopy, 129, 130, 131, 132.  
 Kind of script used in schools, 414, 415.  
 Knapp on antiseptic, 474.  
 Kneass, McFarland and, on the micro-organisms of the conjunctiva and lacrymal sac, 489.  
 Kny's case for surgical dressings, 483.  
 sterilizer, 481.  
 water-sterilizing tank, 482.  
 Koch's steam-boiler, 479.  
 Koroscopic, 109.  
 Küchler's test-types, 23.

## L.

- Lactation a cause of blindness, 457.  
 Lamina cribrosa, the, 84.  
 Landolt on antiseptic, 474.  
 Lantern-rest, Holmgren's, 343.  
 Welsh's, 343.  
 Laqueur on lateral illumination, 47.  
 Lateral illumination, concave mirror in, 49.  
 examination of the eye by, under pathological conditions, 52, 53, 54, 55.  
 of the normal eye by, 51, 52.  
 historical notes concerning, 48.

- Lateral illumination in atrophy of the iris, 53.  
 in chorioidal tumors, 55.  
 in conjunctival diseases, 55.  
 in detection of entozoa, 53.  
 of floating lens-particles, 53.  
 of foreign bodies, 52, 53.  
 in diseases of the vitreous, 55.  
 in dislocated lens, 53.  
 in hyphæma, 53.  
 in hypopyon, 53.  
 in injuries of the iris, 53.  
 in interstitial keratitis, 52.  
 in iritis serosa, 52, 53.  
 in keratitis punctata vera, 52.  
 in lens diseases, 54, 55.  
 in leucoma, 54.  
 in neoplasms of the iris, 53.  
 in retinal tumors, 55.  
 in scrofulous vascular keratitis, 52.  
 in staphyloma of the cornea, 55.  
 in synechia, 53, 54.  
 L. Laqueur on, 47.  
 means used in combination with, for the purpose of magnifying, 57.  
 method of examining by, 49, 50.  
 Noyes's apparatus for, 50.  
 other factors concerned in, 48.  
 Priestley Smith's apparatus for, 50.  
 principle of, 47, 48.  
 rarer applications of, 55.  
 sclerosis a cause of blindness, 452.  
 ventricles, descending cornu of, 297.  
 Lautenschläger's sterilizer, 480.  
 Lead poisoning a cause of blindness, 458.  
 Leading of type in school-books, 411.  
 Left hypercyclophoria, 172.  
 hypercyclophoria, 172.  
 hyperphoria, 172.  
 hypertropia, 183.  
 sursumduction, 179.  
 Length of lines in school-books, 414.  
 Lens, crystalline, ophthalmometry of the, 138, 139.  
 decentred, geometrical centre of a, 151.  
 diseases, lateral illumination in, 54, 55.  
 dislocated, lateral illumination in, 53.  
 -particles, floating, lateral illumination in detection of, 53.  
 Stevens's stenopaic, 177, 178.  
 Stokes, 164.  
 Lenses, spectacle, examination of, 152, 153, 154, 155, 156.  
 Lepra a cause of blindness, 453.  
 Lesions affecting the optic fibres in the cerebral hemispheres, visual field in, 296.  
 of the primary optic centres, diagnosis of, 295.  
 focal symptoms of, 295.  
 Letters in school-books, size and form of, 410.  
 Leucoma, lateral illumination in, 54.  
 Leucomata, corneal, detection of, 81.  
 Leukoscope, Helmholtz's, 347.  
 Liebreich's corneal microscope, 60.  
 ophthalmoscope, 69, 70, 72.  
 Light area, form of, in skiascopy, in irregular astigmatism, 98.  
 in regular astigmatism, 95, 96.  
 in the pupil in skiascopy, form of, in hyperopia and myopia, 95.  
 in skiascopy, appearance of, 97.  
 of the face, 92.  
 retinal, in skiascopy, 92.  
 best arrangements of, in skiascopy, 94.  
 immediate source of, in skiascopy, 92, 163.  
 in school-buildings, direction of, 390.  
 quantity of, 385.

- Light in the pupil, apparent movement of, in skiascopy, 93.  
 rapidity of movement of, in skiascopy, 93.  
 on the retina, movement of, 90.  
 original source of, in skiascopy, 92, 163.  
 passage of, through a plane refracting surface, 143.  
 -sense, 191.
- Lighting of school-buildings, 385.
- Line, base-apex, of a prism, 141.  
 visual, the, 167, 189.
- Lingual lobe, 284.
- Lobulus lingualis, 298.
- Location of school-buildings, 382.
- Long primer type in school-books, 410.
- Loring's ophthalmoscope, 72, 73.
- Lotz's test-types, 27.
- Loupe, binocular, Saemisch's, 58.  
 Westien's, 58.  
 Bruecke's, 57, 58.  
 Hartnack's, 57.  
 Nachet's, 57.  
 Steinheil's, 57.

## M.

- McFarland and Kneass on the micro-organisms of the conjunctiva and lacrymal sac, 489.
- Macropia from myosis, 41.
- Macula, 86, 87.  
 fibres of the, 295.  
 halo of the, 87.
- Macular crossed bundle of the optic nerve, 241.  
 fasciculus, 295.  
 uncrossed bundle of the optic nerve, 241.  
 dorsal portion of the, 241.  
 ventral portion of the, 241.
- Maddox double prism, 165.
- Magnus's table of causes of blindness, 433.
- Malachite green in antiseptis, 472.
- Manifest esophoria, 174.  
 exophoria, 175.
- Maps in schools, 409.
- Mariotte's spot in binocular field of vision, 200, 212.  
 in congenital coloboma, 201.
- Matching of colors, 331.
- Mauthner's test, 343.
- Means used in combination with lateral illumination for the purpose of magnifying, 57.
- Measles a cause of blindness, 451, 453, 456.
- Measurement of prismatic glasses, 155.
- Measurements to determine arrangement of school-desk and seat, 401.
- Media, transparency of, influence of, on acuity of vision, 17.
- Medullated nerve-fibres in the retina, visual field in, 216.
- Meningitis a cause of blindness, 451.  
 cerebro-spinal, a cause of blindness, 456.
- Mercurial poisoning a cause of blindness, 458.
- Mercury in progressive atrophy of the optic nerve, 246.
- Meridian, vertical, relation of defects of field of vision to, 209.
- Method of examining by lateral illumination, 49, 50.  
 of Groenouw in determining isopters, 197.
- Methods for the estimation of the balance of the extra-ocular muscles, 167.  
 of determining the acuity of vision, Herman Snellen, 11.  
 of examining the eye, 79.  
 of obtaining the field of vision, 192.
- Metre-angle system, 150.
- Meyer, E., on antiseptis, 474.
- Meyerstein's ophthalmoscope, 66.
- Micrococcus candidans, 528.  
 Pasteri, 506.  
 pneumoniae crouposa, 464.  
 tetragenus, 464, 530.
- Micro-organism of trachoma, 534.
- Micro-organisms in the air, 465.  
 of the conjunctival sac of a healthy eye, 467.  
 of the conjunctiva and lacrymal sac, J. McFarland and S. S. Kneass, 489.
- Microphthalmia a cause of congenital blindness, 434.
- Middle division of the visual paths, 284.
- Mirrors, plane and concave, in skiascopy, relative advantages of, 106, 107.
- Modified curriculum in schools, 379.
- Moist heat in antiseptis, 473.
- Monochromatics, 318.
- Monocular diplopia, 167.  
 squint, binocular field of vision in, 213.
- Monoplegia, hemianopsia with, 297.
- Morphine as a myotic, 46.  
 in ill effects of atropine, 36.
- Morton's ophthalmoscope, 73, 74.
- Movement of light in the pupil in skiascopy, apparent, 93.  
 rapidity of, 93.  
 on the retina, 90.
- Multiple sclerosis, temporal hemianopsia in, 277.  
 visual field in, 208.
- Muscarine, action of, 46.
- Muscles, extra-ocular, balance of the, 167.  
 ocular examination of paralysis of the, 187.
- Mydriasis, action of myotics in, 44.
- Mydriatics and myotics, Herman Snellen, Jr., 31.  
 methods of application of, 31.  
 use of, 79.
- Mydrin, action of, 39.
- Myopia a cause of blindness, 459.  
 and hyperopia, form of light area in the pupil in skiascopy in, 95.  
 application of concave mirror in skiascopy to, 105.  
 of plane mirror in skiascopy to, 101.  
 decrease of, 376, 378.  
 effect of, on the field of vision, 192.  
 high-grade, causing hemeralopic fields, 207.  
 in schools, 354.  
 results of optical correction of asthenopic eyes in arresting, 374.  
 significance of, 358.
- Myotic, arecoline as a, 46.  
 eserine as a, 45.  
 extract of aconitine as a, 46.  
 of digitaline as a, 46.  
 morphine as a, 46.  
 muscarine as a, 46.  
 nicotine as a, 46.  
 nitrogen protoxide as a, 46.  
 physostigmine as a, 45.  
 pilocarpine as a, 45, 46.
- Myotics, action of, 40, 41, 42, 43, 44.  
 in corneal ulcers, 45.  
 in glaucoma, 44.  
 in irregular astigmatism, 45.  
 in mydriasis, 44.
- mydriatics and, Herman Snellen, Jr., 31.

## N.

- Nachet case of lenses, 163.
- Nachet's loupe, 57.
- Naming of colors, 330.
- Nasal portion of the eye, relation of, to the temporal portion, 209.

- Near vision, tests for, 20.  
 Negative central scotoma, 198.  
 Nerve, optic, anatomy of the, 240.  
   inflammations of the, 234, 235.  
   mercury in progressive atrophy of the, 246.  
   relation of central visual acuteness to defects of the visual field in diseases of the, 240.  
   symptoms of diseases of the, 215.  
   visual field in diseases affecting the, 234.  
 Nerve-fibre path in the optic tract, 289.  
 Nerve-fibres, medullated, in the retina, visual field in, 216.  
 opaque, 84.  
   diagnosis of, from albuminurie retinitis, 84.  
   from enlarged conus, 84.  
   from posterior staphyloma, 84.  
 Nerve-head, optic, 85.  
 Nervous disturbances, functional, visual field in, 307.  
 Neuritis, axial, visual field in, 251.  
   basal gummatous, visual field in, 269.  
   hereditary, visual field in, 252, 260.  
   interstitial gummatous, visual field in, 258.  
   optic, descending, visual field in, 248.  
 New wool test, Thomson's, 341.  
 Nicati's test-types, 28, 29.  
 Nicotine as a myotic, 46.  
 Niden's test-types, 26.  
 Nitro-atropine in the prevention of atropinism, 36.  
 Nitrogen protoxide as a myotic, 46.  
 Normal field of vision, 196.  
   effect of strychnine on, 196.  
 Noyes's apparatus for lateral illumination, 50.  
   bar arrangement of rhomb-shaped prisms, 163, 164.  
   Emerson's modification of, 164.  
   stereoscope for square prisms, 164.  
 Nuel on antiseptics, 474.  
 Nystagmus a cause of congenital blindness, 439.
- O.**
- Oblique illumination, 47, 80.  
 Occipital division of the visual paths, 284.  
   lobes, 284, 299.  
 Occlusion of the pupil, detection of, 81.  
 Occupation, influence of, on eye-disease, 459.  
 Ocular ballotement, 80.  
   muscles, examination of paralysis of the, 187.  
 Oil of turpentine in antiseptics, 472.  
 Ole Bull on antiseptics, 474.  
 Oliver's test for color-sense, 345.  
   test-types, 26.  
   wool test, 342.  
 Onyx, detection of, 81.  
 Opacities in the anterior chamber, detection of, 81.  
   parallactic movement of, 81.  
   in the vitreous, detection of, 80.  
 Opaque nerve-fibres, 84.  
 Operation, preparation of instruments for, 486.  
   of operator for, 434.  
   of patient for, 483.  
 Operations, unsuccessful, a cause of blindness, 456.  
 Ophthalmia neonatorum a cause of blindness, 442.  
   prevention of, 443, 444.  
   statistics of, 442.  
   traumatic, sympathetic, a cause of blindness, 450.  
 Ophthalmometer, artificial astigmatic cornea in the, 119.  
 Ophthalmometer, directions for using the, 119, 120, 121, 122.  
   of Helmholtz, 112, 113, 114, 115.  
   of Javal and Schiötz, latest model, 117.  
   original model, 115, 116.  
   of Laurent, 115.  
   purposes and uses of the, 111.  
 Ophthalmometry after cataract operations, 122, 123.  
   and its clinical applications, Adolphe Javal, Jr., 111.  
   of the crystalline lens, 138, 139.  
   of different parts of the anterior surface of the cornea, 129.  
   of the posterior surface of the cornea, 134, 135, 136, 137.  
   practical applications of, 126, 127, 128, 129.  
 Ophthalmophakometer of Tscherning, 134, 135.  
 Ophthalmoscope, the, and the art of ophthalmoscopy, G. M. Gould, 63.  
 Coeius's, 68.  
   combined use of the, and the magnifying glass, 56.  
 Epkeus's, 68.  
 Epkens-Donders's, 70.  
 Frobelius's, 66.  
 Hawes's, 74.  
 Helmholtz's, 65, 66.  
   history of the, 63, 64.  
 Liebreich's, 69, 70, 72.  
 Loring's, 72, 73.  
 Meyerstein's, 66.  
 Morton's, 73, 74.  
   physics of the, 75, 76.  
 Rekos's, 67.  
 Reute's, 68.  
 Stellwag von Carion's, 69.  
 Ulrich's, 66, 68, 69.  
 Ophthalmoscopic image, reversal of, 89.  
 Ophthalmoscopy, direct, 78.  
   indirect, 78, 79.  
 Oppenheimer's table of causes of blindness, 437.  
 Optic atrophy, partial, 238.  
   prognosis of, 239, 240.  
   simple true, visual field in, 235.  
   centres, primary, hemianopsia in lesions of the, 294.  
   disk, 85.  
   fibres in the cerebral hemispheres, visual field in diseases affecting the, 296.  
   nerve, anatomy of the, 240.  
   crossed bundle of the, 241, 242.  
   idiopathic atrophy of the, a cause of blindness, 447.  
   mercury in progressive atrophy of the, 246.  
   relation of central visual acuteness to defects of the visual field in diseases of the, 240.  
   symptoms of diseases of the, 215.  
   uncrossed bundle of the, 241, 242.  
   visual field in diseases affecting the, 234.  
   in inflammations of the, 234, 235.  
   in progressive atrophy of the, 259.  
 nerve-head, 85.  
 neuritis, descending, visual field in, 248.  
 papilla, 85.  
   symptoms of diseases of the, 215.  
 tract, defects of the visual field in descending atrophy of the, 245.  
   defects of the visual field in diseases of the, 242.  
   groups of, 242.  
 Optical correction of asthenopic eyes, results of, in arresting myopia, 374.

- Orthophoria, 172.  
 Orthoscope, Arlt's, 71.  
   Coccius's, 71.  
   Czernak's, 71.  
 Overshot field of vision, 265.  
   portion of the visual field, 279, 280, 281.
- P.
- Panas on antiseptics, 474, 475.  
 Paper squares, use of, to determine the field of vision, 192, 193.  
 Papilla, optic, 85.  
   symptoms of diseases of the, 215.  
 Papillitis, visual field in, 231, 232, 233, 234.  
 Paracentral scotoma, 198, 199.  
   bilateral, 199.  
 Parallax movement of opacities in anterior chamber, 81.  
 Parallax test for heterotropia, 184.  
 Paralysis of the ocular muscles, diagnosis of, 187.  
   examination of, 187.  
   general scheme of diplopia in, 188.  
 Paretic dementia a cause of blindness, 452.  
 Parietal lobe, the, 297.  
 Partial optic atrophy, 238.  
 Pathogenic bacteria which do not form spores, 469.  
 Paths of nerve-fibres in the chiasm, 262.  
 Perception, clear-sight, 300.  
   deadened, zones of, 274.  
 Perforating wounds of the sclerotic and chorioid, visual field in, 221, 222.  
 Pericentral scotoma, 198.  
 Perimeter, bed-, Wilbrand's, 210.  
   Förster's, 194, 195.  
   test of peripheral fields of color, 348.  
 Perimetry and its clinical value, H. Wilbrand, translated by T. R. Pooley, 189.  
   in hemeralopia, 206.  
   symptomatic, 207.  
 Periostitis, temporal hemianopsia in, 277.  
 Peripapillary chorio-retinitis, 200.  
 Peripheral zone, 203.  
   of visual field, varieties of defects of, 209.  
 Perlia's fibres, 285.  
 Perpendicular illumination, 48.  
 Persistence of the hyaloid artery, 85.  
   of the pupillary membrane a cause of congenital blindness, 439.  
 Pflüger's test-typos, 26.  
 Phagocytosis, theory of, 465.  
 Philadelphia schools, conus in, 368.  
   emmetropia in, 370.  
   examinations in, 364.  
   hypermetropia in, 370.  
   hypermetropic astigmatism in, 370.  
   mixed astigmatism in, 370.  
   myopia in, 366, 370.  
   myopic astigmatism in, 370.  
 Phlyctenular conjunctivitis a cause of congenital blindness, 440.  
 Phorometer, Stevens's, 165, 176.  
 Physiological point of vision, 197.  
 Physostigmine, 45.  
 Pilocarpine, action of, 45.  
   in ill effects of atropine, 36.  
 Plane and concave mirrors in skiascopy, relative advantages of, 106, 107.  
   mirror in skiascopy, practical application of, 99.  
   to emmetropia, 101, 102.  
   to hyperopia, 99, 100, 101.  
   to irregular astigmatism, 163.  
   to myopia, 101.  
   to regular astigmatism, 102.
- Plane of a prism, 141.  
   refracting surface, passage of light through a, 143.  
 Point of regard, 168.  
   of reversal, 90.  
 Points, spatial, of the retina, 169.  
 Pooley, T. R., translator of Wilbrand's article on perimetry and its clinical value, 189.  
 Porcelain slate in schools, 408.  
 Position assumed in writing, 414.  
 Positive central scotoma, 198.  
 Posterior longitudinal bundle, 284.  
   staphyloma, diagnosis of, from opaque nerve-fibres, 84.  
   surface of the cornea, ophthalmometry of, 134, 135, 136, 137.  
 Power of convergence, 182.  
 Practical application of concave mirror in skiascopy, 103.  
   to aberration, 106.  
   to emmetropia, 105.  
   to hyperopia, 104.  
   to irregular astigmatism, 106.  
   to myopia, 105.  
   to regular astigmatism, 105.  
   of ophthalmometry, 126, 127, 128, 129.  
   of skiascopy, 91, 99.  
   to emmetropia, 101, 102.  
   to hyperopia, 99, 100, 101.  
   to irregular astigmatism, 103.  
   to myopia, 101.  
   to regular astigmatism, 102.  
 Pregnancy a cause of blindness, 457.  
 Prentice's prismometer, 155.  
 Preparation of dressings, 479.  
   Andrews's portable sterilizer for, 487.  
   Kny's case for surgical dressings, 483.  
   sterilizer for, 481.  
   water-sterilizing tanks, 482.  
   Koch's steam-boiler in, 479.  
   Laudenschläger's apparatus for, 480.  
   Schimmelbusch's apparatus for, 480.  
   steam in, 479.  
 Prevention of atropinism, 36.  
   boric acid in, 36.  
   nitro-atropine in, 36.  
   salicylate of atropine in, 36.  
   of blindness, 460.  
   possibilities of, 460, 461.  
 Priestley Smith on antiseptics, 473, 474.  
 Priestley Smith's apparatus for lateral illumination, 50.  
 Primary optic centres, hemianopsia in lesions of the, 294.  
 Principal plane of a prism, 141.  
   section of a prism, 141.  
 Principles of and the methods for the estimation of the balance of the extra-ocular muscles, G. T. Stevens, 167.  
   of correct and faulty sitting, 398.  
   of lateral illumination, 47, 48.  
   of reversibility, 144, 146.  
 Prism, apex of a, 141.  
   base-apex line of a, 141.  
   constants of a, 151.  
   definition of a, 141.  
   determination of a, 158.  
   deviation through a, 141.  
   -diopter, 149.  
   system, 150.  
   double, Maddox, 165.  
   edge of a, 141.  
   plane of a, 141.  
   principal plane of a, 141.  
   section of a, 141.  
   refracting angle of a, 141.  
   determination of, 158.

- Prism, Wollaston, 166.  
 Prismatic color-phenomena, 148.  
   glasses, measurement of, 155.  
 Prisme mobile, Creté, 164.  
   Jackson's, 165.  
   Risler's, 165.  
 Prismometer, Prentice's, 155.  
 Prisms and prismometry, W. S. Dennett, 141.  
   Herschel combinations of, 164.  
   Noyes's arrangement of rhomb-shaped, 163,  
     164.  
     Emerson's modification of, 164.  
   Noyes's stereoscope for square, 164.  
   temporary, 181.  
 Prodromal abortive attacks of glaucoma, visual  
 field in, 229.  
 Prognosis of simple true optic atrophy, 239.  
 Progressive atrophy of the optic nerves, mer-  
 cury in, 246.  
   visual field in, 259.  
 Proteus vulgaris, 526.  
 Pseudo-isochromatic wools, Donders's, 343.  
 Psychical color-blindness, 324.  
 Pulsation, physiologic, of the veins of the retina,  
 86.  
 Pulvinar, 284, 296.  
 Pupil, apparent movement of light in, in skias-  
 copy, 93.  
   detection of occlusion of, 81.  
   determination of size of, 81.  
   effect of width of, on the field of vision, 192.  
   light area in, in skiascopy, form of, in hy-  
   peropia and myopia, 95.  
   rapidity of movement of light in, in skias-  
   copy, 93.  
   size of, determination of, 81.  
 Pupillary membrane, persistence of a course of  
 congenital blindness, 439.  
 Pupilloscopic, 109.  
 Purposes and uses of the ophthalmometer, 111.  
 Pyoktanin in antiseptis, 472.
- Q.
- Quantities of test-objects, 13.  
 Quantity of light in school-buildings, 385.
- R.
- Rapidity of movement of light in the pupil in  
 skiascopy, 93.  
 Rare applications of lateral illumination, 55.  
 Reactions of the pupil, determination of, 81.  
 Reading habit, effects of the, 381.  
 Red-blindness, 316, 319.  
 Red-green blindness, 319.  
 Reduced color-sense, 317, 321.  
 Re-examination for color-blindness, 352.  
 Reflex visual fibres, 284.  
   winking, use of, to determine the field of  
   vision, 192.  
 Refracting angle of a prism, 141.  
   determination of the, 158.  
   system, 150.  
   surface, plane, passage of light through a,  
   143.  
 Refraction, accommodation, and glasses, effect  
 of, on acuity of vision, 17.  
 Regard, field of, 169.  
   point of, 168.  
 Regular astigmatism, application of concavo  
 mirror in skiascopy to, 105.  
   plane mirror in skiascopy to, 102.  
 Rekow's disks, 67, 70.  
   ophthalmoscope, 67.  
 Relapsing fever a cause of blindness, 456.  
   syphilitic retinitis, central, visual field in,  
   220.  
 Relation of age to blindness, 428.  
   of central visual acuteness to the defects of  
   the visual field in diseases of the optic  
   nerves, 240.  
   in temporal hemianopsia, 275.  
   of climate to blindness, 426.  
     Zeunc's law of, 427.  
   of color-limits, 205, 206.  
   of colors to white, 206.  
   of defects of field of vision to vertical me-  
   ridian, 209.  
   of nasal to temporal portion of eye, 209.  
   of sex to blindness, 429.  
 Relative advantages of the plane and concave  
 mirrors in skiascopy, 106, 107.  
   central scotoma, 198.  
 Representation, diagrammatic, of corneal astig-  
 matism, 132, 133, 134.  
 Results of the optical correction of asthenopic  
 eyes in arresting myopia, 374.  
 Retina and chorioid, visual field in diseases of  
 the, 214.  
   central artery of the, 86.  
     veins of the, 86.  
     pulsation of, 86.  
   cortical, 299.  
   detachment of, a cause of blindness, 446.  
     in schools, 360.  
   medullated nerve-fibres in visual field in the,  
   216.  
   movement of light on the, 90.  
   spatial point of the, 169.  
   visual field in embolism of the central artery  
   of the, 220, 221.  
 Retinal colobomata, 216.  
   visual field in, 216.  
   hemorrhage, visual field in, 217, 218.  
   image, the, 11.  
   layers, inner, symptoms of diseases of, 215.  
     outer, symptoms of diseases of, 215.  
   light area in skiascopy, 92.  
   tumors, lateral illumination in, 55.  
 Retinitis, albuminuric, visual field in, 218, 219,  
 220.  
   pigmentosa a cause of congenital blindness,  
     439.  
     visual field in, 226, 227.  
     visus reticulatus in, 228.  
   proliferans, visual field in, 220.  
   syphilitic, central relapsing, visual field in,  
   220.  
 Retino-chorioiditis, symptoms of, 215.  
 Retino-papillitis, visual field in, 231, 232, 233,  
 234.  
 Rétinoscopie, 109.  
 Retinoscopy, skiascopy (the shadow-test), and its  
 practical application, Edward Jackson, 89.  
 Retrobulbar disease, visual field in, 249.  
 Reuss's color-tables, 343.  
 Reute's ophthalmoscope, 68.  
 Reversal of the ophthalmoscopic image, 89.  
   point of, 90.  
 Reversibility, the principle of, 144, 146.  
 Review of different test-types, 23.  
 Right hyperesophoria, 172.  
   hyperesophoria, 172.  
   hyperphoria, 172.  
   hypertropia, 172, 183.  
   sursunduction, 179.  
 Ring, chorioidal, 86.  
   scleral, 86.  
   scotoma, 201, 202, 203.  
     demonstration of, 207.  
 Risler's prisme mobile, 164.



Risley on school hygiene, 353.  
Rod test for heterophoria, 177.  
Russia, blindness in, 426.

## S.

- Saemisch's binocular loupe, 58.  
Salicylate of atropine in the prevention of atropinism, 36.  
of escrine, 45.  
Salicylic acid in antiseptics, 472.  
Sarcina alba, 531.  
Scarlatina a cause of blindness, 451.  
Scarlet fever a cause of blindness, 453, 456.  
Schenke's yarn-covered spools, 343.  
Schimmelbusch's sterilizer, 480.  
Schmidt-Rimpler on antiseptics, 475.  
School-blackboards, 407, 408.  
-books, 407.  
  leading of type in, 411.  
  length of lines in, 414.  
  size and form of letters in, 410.  
  type in, 410.  
-buildings, architecture of, 382.  
  artificial illumination in, 395.  
  construction of, 383.  
  desks of, 384.  
  direction of light in, 390.  
  exposure of, 396.  
  lighting of, 385.  
  location of, 382.  
  quantity of light in, 385.  
-desk and seat, 400.  
  minus distance of, 401.  
  hygiene, Smith's, 403.  
-furniture, 397.  
hygiene, S. D. Risley, 353.  
-maps, 407, 409.  
-room, hygiene of the, 379.  
-work required at home, 380.  
Schools, cataract in, 360.  
  defects of vision in, 353.  
  detachment of the retina in, 360.  
  diseases of the vitreous in, 360.  
  emmetropia in, 354.  
  hereditary predisposition and congenital anomalies in the form of the eyeball in, 362.  
  hypermetropia in, 354.  
  inflammation of the chorioid in, 360.  
  kind of script used in, 414, 415.  
  modified curriculum in, 379.  
  myopia in, 354.  
  necessity for entrance examination in, 371.  
  term examinations in, 332.  
Schweigger on antiseptics, 474.  
Schweigger's test-types, 23.  
Scleral ring, 86.  
Sclero-chorioiditis, visual field in, 228.  
Sclerotic and chorioid, visual field in perforating wounds of the, 221, 222.  
Seopolamine, action of, 38.  
Scotland, blindness in, 423.  
Scotoma, central, 197.  
  absolute, 197, 198.  
  indistinct, 198.  
  negative, 198.  
  of fatigue, 199.  
  positive, 198.  
  relative, 198.  
  homonymous hemianopsia, 199.  
  insular, 203.  
  para-central, 198, 199.  
    bilateral, 199.  
  pericentral, 198.  
  ring, 201, 202, 203.  
    demonstration of, 207.  
  Scotoma, temporal hemianopsia, 199.  
  Scrofula a cause of blindness, 458.  
  Seat of color-blindness, 226.  
  Seat-bones line, 398.  
  Senile eyes causing hemeralopia fields, 207.  
  Sequence of test-objects, 16.  
  Sex, relation of, to blindness, 429.  
  Sexual organs, diseases of, a cause of blindness, 452.  
Shadow-test, 109.  
  (skiascopy, retinoscopy), and its practical application, Edward Jackson, 89.  
Shot-silk phenomenon in children, 87.  
Signals, change of the colors of, 328.  
Significance of myopia, 358.  
Simple glaucoma, visual field in, 229, 230, 231.  
  true optic atrophy, visual field in, 235.  
Simulation of defects in the visual field, 312.  
  Wilbrand's string apparatus for detection of, 313.  
Simultaneous contrast-test, Stilling's, 346.  
Single standard desk and seat, 403.  
Sitting, principles of correct and faulty, 398.  
Size and form of letters in school-books, 410.  
Skiascopy, apparatus for, 108.  
  apparent movement of light in the pupil in, 93.  
  appearance of light area in aberration in, 97.  
  best arrangement of light in, 94.  
  form of light area in irregular astigmatism in, 98.  
  in the pupil in hyperopia and myopia in, 95.  
  in regular astigmatism in, 95, 96.  
  history and name of, 108, 109.  
  immediate source of light in, 92.  
  light area of the face in, 92.  
  near-point of accommodation in, 103.  
  original source of light in, 92.  
  practical application of, 91, 99.  
    concave mirror in, 103.  
      to aberration, 106.  
      to emmetropia, 105.  
      to hyperopia, 104.  
      to irregular astigmatism, 106.  
      to myopia, 105.  
      to regular astigmatism, 105.  
    plane mirror in, 99.  
      to emmetropia, 101, 102.  
      to hyperopia, 99, 100, 101.  
      to irregular astigmatism, 103.  
      to myopia, 101.  
      to regular astigmatism, 102.  
  rapidity of movement of light in the pupil in, 93.  
  retinal light area in, 92.  
  source of light in, immediate, 92, 103.  
    original, 92, 103.  
  (the shadow-test, retinoscopy) and its practical application, Edward Jackson, 89.  
  uses to be made of, 107.  
Small-pox a cause of blindness, 453, 454.  
Snee's test-types, 23.  
Snake-bite a cause of blindness, 459.  
Snellen, Herman, on the methods of determining the acuity of vision, 11.  
Snellen, Herman, Jr., on mydriatics and myotics, 31.  
Snellen's test-letters in determining isopters, 197.  
  test-types, 23, 24.  
Snell's law of deviation, 142.  
Source of light in skiascopy, immediate, 92, 103.  
  original, 92, 103.  
Spatial points of the retina, 169.  
Special devices for the cure of weak eyes, 416.  
Spectacle lenses, examination of, 152, 153, 154, 155, 156.

- Spectral color-test, 346.  
 Sphero-prism, examination of, 158.  
 Spinal cord, diseases of, a cause of blindness, 451.  
   nervo affections, visual field in, 259.  
 Spools, yarn-covered, Sehenke's, 343.  
 Spore-bearing bacteria which excite wound-infection, 469.  
 Spores, pathogenic bacteria which do not form, 469.  
 Spot, blind, 200.  
   in congenital coloboma, 201.  
   Mariotte's, 200.  
   in congenital coloboma, 201.  
 Squares of paper, use of, to determine the field of vision, 192, 193.  
 Squint, concomitant, 172.  
   monocular, binocular field of vision in, 213.  
 Staphylococcus cereus albus, 466, 531.  
   flavus, 464.  
   epidermidis albus, 467, 532.  
   pyogenes albus, 464, 467, 469, 532.  
     aureus, 464, 466, 467, 469, 531.  
     citreus, 464, 469, 533.  
 Staphyloma of the cornea, lateral illumination in, 55.  
 Statistics of congenital color-blindness, 325.  
 Steam in the preparation of dressings, 479.  
 Steiger's test-types, 27.  
 Steinheil's loupe, 57.  
 Stellwag von Carion's ophthalmoscope, 69.  
 Stenopæic lens, Stevens's, 177, 178.  
 Stereoscope, Noyes's, for square prisms, 164.  
 Stevens on the principles of and the methods for the estimation of the balance of the extra-ocular muscles, 167.  
 Stevens's phorometer, 165, 176.  
   in determining esophoria, 177.  
   exophoria, 177.  
   hyperphoria, 177.  
   stenopæic lens, 177, 178.  
 Stilling's simultaneous contrast test, 346.  
 Stokes's lens, 164.  
 Strabismus, 171.  
   alternating, 173.  
   convergent, binocular field of vision in, 212.  
   divergent, binocular field of vision in, 213.  
 Straub's test-types, 28.  
 Streptococcus of erysipelas, 466.  
   pyogenes, 466, 469, 533.  
 Striedingen's test-types, 24.  
 Strychnine, effect of, on normal field of vision, 196.  
 Sulphuric acid in antiseptics, 472.  
 Sursunduction, 179, 180.  
   left, 179.  
   right, 179.  
 Sweden, blindness in, 425.  
 Sympathetic ophthalmia, traumatic, a cause of blindness, 450.  
 Symptomatic hemeralopia, perimetry in, 207.  
 Symptoms of diseases of the inner retinal layers, 215.  
   of the optic nerve, 215.  
   of the outer retinal layers, 215.  
   of the papilla, 215.  
   of retino-chorioiditis, 215.  
 Synecchia, detection of, 81.  
   lateral illumination in, 53, 54.  
 Syphilis a cause of blindness, 457.  
   a cause of congenital blindness, 440.  
   central and spinal, visual field in diseases of the optic nerve common in, 259, 260.  
   temporal hemianopsia in, 277.  
 Syphilitic retinitis, central relapsing, visual field in, 220.
- T.
- Tabes dorsalis a cause of blindness, 452.  
   visual field in, 257, 259.  
 Tapetum lucidum, the, 63.  
 Temporal gyrus, second, 296.  
   hemianopsia in aneurisms, 277.  
   in diseases of the chiasm, 262, 266.  
   in elephantiasis, 277.  
   in hemorrhages into the chiasm, 277.  
   in hydrocephalus, 277.  
   in multiple sclerosis, 277.  
   in periostitis, 277.  
   in syphilis, 277.  
   in trauma, 277.  
   in tubercle, 277.  
   in tumors, 277.  
   relation of central visual acuteness in, 275.  
   hemianopsie scotoma, 199.  
   lobes, left, 297.  
   to nasal portion of eye, relation of, 209.  
   suleus, second, 296.  
 Temporary prisms, 181.  
 Ten-point type in school-books, 410.  
 Term examinations in schools, 382.  
 Test disks, Jeaffreson's, 342.  
   for central color-scotoma, 348.  
   for color-sense, Carter's, 345.  
     Donders's, 343.  
     Oliver's, 345.  
 lantern, Holmgren's, 343.  
   Welsh's, 343.  
 -letters of Snellen in determining isopters, 197.  
 new wool, Thomson's, 341.  
 -objects, quantities of, 13.  
   sequence of, 16.  
 parallax, for heterotropia, 184.  
 spectral color, 346.  
 -types, Albrand's, 26.  
   Boetteher's, 24.  
   Burehardt's, 24, 25.  
   Cohn's, 26.  
   de Weeker's, 27.  
   Fuehs's, 28.  
   Galezowski's, 27.  
   Guillery's, 25, 26.  
   Jaeger's, 28.  
   Kuehler's, 23.  
   Lotz's, 27.  
   Nietzi's, 28, 29.  
   Nieden's, 26.  
   Oliver's, 26.  
   Pflüger's, 26.  
   review of different, 23.  
   Schweigger's, 23.  
   Smee's, 23.  
   Snellen's, 23, 24.  
   Steiger's, 27.  
   Straub's, 28.  
   Striedingen's, 24.  
   von Carion's, 23.  
   Weiss's, 27.  
   Wolffberg's, 27.  
   wool, Holmgren's, 331.  
   Oliver's, 342.  
 Tests for color-blindness, 330.  
   for near vision, 20.  
 Thomson and Weiland on detection of color-blindness, 315.  
 Thomson's color-stick, 336.  
   new wool test, 341.  
 Tobacco amblyopia, visual field in, 260.  
   poisoning a cause of blindness, 458.  
 Total color-blindness, 316, 322.  
 Toxic amblyopia, visual field in, 249, 252.

Tract, hemianopsia due to disease of the, 289.  
 diagnosis of, 291, 292, 293.  
 hemorrhages of the, 290.  
 nerve-fibre path in the, 289.  
 optic, defects of the visual field in descending atrophy of the, 245.  
 defects of the visual field in diseases of the, 242.  
 groups of, 242.  
 tumors pressing on the, 290.  
 Transparency of media, influence of, on acuity of vision, 17.  
 Trauma, temporal hemianopsia in, 277.  
 Traumatic sympathetic ophthalmia a cause of blindness, 450.  
 Traumatism, blindness due to, 448.  
 Tropometer, 185.  
 Trousseau's table of causes of blindness, 434.  
 Tscherning, ophthalmophakometer of, 135.  
 Tubercle, temporal hemianopsia in, 277.  
 Tuberculosis a cause of congenital blindness, 440.  
 Tumors, chorioidal, lateral illumination in, 55.  
 retinal, lateral illumination in, 55.  
 temporal hemianopsia in, 277.  
 Type of books in schools, 407, 409.  
 Typhoid fever a cause of blindness, 451, 455.

## U.

Ulcers, corneal, detection of, 81.  
 Ulrich's ophthalmoscope, 66, 68, 69.  
 Uncrossed bundle of the optic nerve, 241, 242.  
 dorsal portion of the, 241, 242.  
 ventral portion of the, 241, 242.  
 macular, of the optic nerve, 241.  
 dorsal portion of the, 241.  
 ventral portion of the, 241.  
 Uniocular green-blindness, 319.  
 United States, blindness in the, 420, 421, 422.  
 Unsuccessful operations a cause of blindness, 450.  
 Uropoietic system, diseases of, a cause of blindness, 452.  
 Uses and purposes of the ophthalmometer, 111.  
 Uveal tract, diseases of the, a cause of blindness, 446.

## V.

Value of vision, formula for the, 14.  
 Varieties of defects of peripheral zone of visual field, 209.  
 Vascular system, diseases of the, a cause of blindness, 452.  
 Veins, central, of the retina, 86.  
 pulsation of the, 86.  
 Vertical meridian, relation of defects of field of vision to, 209.  
 Violet-blindness, 318.  
 Vision, acuteness of, for form, 197.  
 for points, 197.  
 defects of, in the schools, 353.  
 effects of age on, 21.  
 field of, 189, 191.  
 binocular, 192.  
 formula for the value of, 14.  
 on the methods of determining the acuity of, H. Snellen, 11.  
 physiological point of, 197.  
 Visual acuity, central, 191.  
 relation of, in temporal hemianopsia, 275.  
 relation of, to the defects in the visual field in diseases of the optic nerve, 240.  
 effect of accommodation, refraction, and glasses on, 17.

Visual acuity, influence of illumination on, 17.  
 of transparency of media on, 17.  
 angle, 13, 22, 169.  
 axis, 189.  
 centre, 298.  
 fibres, association, 284.  
 centrifugal, 284.  
 centripetal, 284.  
 descending, 284.  
 reflex, 284.  
 field, 189.  
 defects of the, in diseases of the optic tract, 242.  
 groups of, 242.  
 in ablatio retinae, 224.  
 in albuminuric retinitis, 218, 219, 220.  
 in axial neuritis, 251.  
 in basal gummatous neuritis, 269.  
 in central relapsing syphilitic retinitis, 220.  
 in choked disk, 231, 232, 233, 234.  
 in chorioidal coloboma, 216.  
 in chorioiditis disseminata, 228.  
 in congenital conus, 217.  
 in contusions of the eye, 223, 224, 225, 226.  
 in descending atrophy of the optic tract, 245.  
 in descending optic neuritis, 248.  
 in diseases affecting the chiasm, 262.  
 affecting the optic nerve, 234.  
 of the nerves of vision common in cerebral and spinal syphilis, 259, 260.  
 of the optic conducting paths from the commencement of the tracts to the cortical centres of vision, 278.  
 of the optic nerve in multiple sclerosis, 260.  
 of the optic nerve not caused by syphilis or chronic intoxication, 260.  
 of the retina and chorioid, 214.  
 in embolism of the central retinal artery, 220, 221.  
 in extra-papillary coloboma, 216.  
 in functional nervous disturbances, 307.  
 in glaucoma, prodromal abortive attacks of, 229.  
 simple, 220, 230, 231.  
 in hemorrhages, 217, 218.  
 in hereditary neuritis, 252.  
 in lesions affecting the optic fibres in the cerebral hemispheres, 296.  
 in medullated retinal nerve-fibres, 216.  
 in multiple sclerosis, 258.  
 in neuritis dependent on hereditary conditions, 260.  
 in papillitis, 230, 231, 232, 233.  
 in perforating wounds of the sclerotic and chorioid, 221, 222.  
 in progressive atrophy of the optic nerve, 259.  
 in retinal coloboma, 216.  
 in retinitis pigmentosa, 226, 227.  
 in retino-papillitis, 231, 232, 233, 234.  
 in retrobulbar disease, 249.  
 in sclero-chorioiditis posterior, 228.  
 in spinal nerve affections, tabes, and dementia, 259.  
 in tabes dorsalis, 257.  
 in tobacco and alcohol amblyopia, 260.  
 in toxic amblyopia, 249, 252.  
 relation of central visual acuteness to defects of the, in diseases of the optic nerve, 240.

- Visual field, simulation of defects in the, 312.  
     Wilbrand's string apparatus  
     for detecting, 313.  
     varieties of defects of peripheral zone  
     of the, 209.  
 paths, 284.  
     frontal division of the, 284.  
     middle division of the, 284.  
     occipital division of the, 284.
- Visus reticulatus, 203.  
     in retinitis pigmentosa, 228.
- Vitreous, diseases of the, in schools, 360.  
     lateral illumination in the, 55.  
     opacities, detection of, 80.
- Von Carion's test-types, 23.  
 Von Gudden's fibres, 285.  
 Von Monakow's fibres, 285.
- W.**
- Warm colors, 319.  
 Watered-silk phenomenon in children, 87.  
 Ways by which pathogenic bacteria may reach  
 a wound, 465.  
 Weak eyes, special devices for the care of, 416.  
 Weiss's test-types, 27.  
 Welsh's lantern test, 343.  
 Westien's binocular loupe, 58.  
 White limits, relation between color and, 206.  
 Wilbrand on perimetry and its clinical value,  
 translated by T. R. Pooley, 189.  
 Wilbrand's bed-perimeter, 210.  
     string apparatus for detecting simulation of  
     defects in the visual field, 313.
- Winking reflex, use of, to determine the field  
 of vision, 192.  
 Wolffberg's test-types, 27.  
 Wollaston prism, 166.  
 Wool test, new, Thomson's, 341.  
     Holmgren's, 331.  
     Oliver's, 342.
- Wools, Donders's pseudo-isochromatic, 343.  
 Wound, ways by which pathogenic bacteria may  
 reach a, 465.  
 Wounds, perforating, of the sclerotic and chori-  
 oid, visual field of, 221, 222.  
 Writing, position assumed in, 414.
- Y.**
- Yarn-covered spools, Schenke's, 343.  
 Yellow-blue blindness, 318.
- Z.**
- Zeune's law of the relation of climate to blind-  
 ness, 427.  
 Zone, color-blind, 205.  
     intermediate, 201.  
     peripheral, 203.  
     of visual field, varieties of defect of,  
     209.  
 Zones of deadened perception, 274.  
 Zonular defects, 207.  
     demonstration of, 207.



# SYSTEM OF THE EYE.

EDITED BY

WILLIAM F. NORRIS AND CHARLES A. OLIVER.

IN FOUR VOLUMES.

*Volume I. now ready. The remaining Volumes will follow at intervals of a few months.*

**Price, Cloth, \$20.00; Sheep, \$24.00; Half-Russia, \$26.00.**

---

BY SUBSCRIPTION ONLY.

---

## GENERAL OUTLINE.

THE first volume of this System includes a most careful study of the embryology and development of the organ, followed by a systematic and extended account of its general anatomy, passing back to those portions of the brain which are in relation. No book of a similar kind has ever made so careful a study of the visual apparatus beyond its entrance into the cranial cavity.

Following this is a succinct and fully illustrated account of the congenital malformations and abnormalities.

Sufficient optics are given in a graphic way to make the physiology of the organ comprehensible, while the associated and more complex relations arising from the presence of two similar and interrelated organs are naturally considered next.

Color-perception, embracing a careful consideration of the most advanced and certain of the newest theories, and a thoroughly practical article upon the photo-chemistry of the retina, conclude the volume.

It will thus be seen that this the first part of the contents gives the fundamental principles upon which the entire System is based.

The second volume treats of the methods of technique in examination, taking each grouping *seriatim*. Beginning with the methods of determination of the acuity of vision and the range of accommodation, mydriatics and myotics, oblique illumination, the ophthalmoscope, the retinoscope, the ophthalmometer, the phorometer, and the perimeter, are all described minutely. The plans for the detection of color-blindness, given in their fullest detail, are next considered, followed by an accurate *résumé* of the conditions underlying the hygiene of the eyes in schools. The article on statistics of blindness is carried further forward and made more general than any other paper or monograph upon the subject. Antisepsis and bacteriological research, including much experimental work and giving the latest views, conclude the volume.

In the third volume are considered all the local diseases of the organ, given in strict logical order, each article being contributed by an author who has made an international reputation in his department. The latter part of the volume, which in reality constitutes a volume in itself, deals with wounds and injuries of the eyeball, sympathetic diseases, and descriptions of the operations usually practised in eye surgery.

The fourth volume considers the relationship between general disturbances and local expressions of such in the eye, making the work a necessity to every general practitioner and specialist in other forms of disease.

# CONTRIBUTORS TO THE "SYSTEM."

---

JOHN A. RYDER, PH.D. . . . .	PHILADELPHIA, PA., U.S.A.
THOMAS DWIGHT, M.D., LL.D. . . . .	BOSTON, MASS., U.S.A.
FRANK BAKER, M.D., PH.D. . . . .	WASHINGTON, D.C., U.S.A.
GEORGE A. PIERSOL, M.D. . . . .	PHILADELPHIA, PA., U.S.A.
ALEX HILL, M.A., M.D. . . . .	CAMBRIDGE, ENGLAND.
WILLIAM LANG, F.R.C.S.E. . . . .	LONDON, ENGLAND.
E. TREACHER COLLINS, F.R.C.S.E. . . . .	LONDON, ENGLAND.
J. MCKEEN CATTELL, PH.D. . . . .	NEW YORK CITY, N.Y., U.S.A.
EUGEN BRODHUN, M.D. . . . .	BERLIN, GERMANY.
WILLIAM THOMSON, M.D. . . . .	PHILADELPHIA, PA., U.S.A.
CARL MAYS, M.D. . . . .	HEIDELBERG, GERMANY.
HERMAN SNELLEN, M.D. . . . .	UTRECHT, HOLLAND.
HERMAN SNELLEN, JR., M.D. . . . .	UTRECHT, HOLLAND.
L. LAQUEUR, M.D. . . . .	STRASSBURG, ALSACE, GERMANY
GEORGE M. GOULD, A.M., M.D. . . . .	PHILADELPHIA, PA., U.S.A.
EDWARD JACKSON, A.M., M.D. . . . .	PHILADELPHIA, PA., U.S.A.
ADOLPHE JAVAL, M.D. . . . .	PARIS, FRANCE.
WILLIAM S. DENNETT, A.M., M.D. . . . .	NEW YORK CITY, N.Y., U.S.A.
GEORGE T. STEVENS, M.D., PH.D. . . . .	NEW YORK CITY, N.Y., U.S.A.
HERMAN WILBRAND, M.D. . . . .	HAMBURG, GERMANY.
SAMUEL D. RISLEY, A.M., M.D. . . . .	PHILADELPHIA, PA., U.S.A.
I. MINIS HAYS, A.M., M.D. . . . .	PHILADELPHIA, PA., U.S.A.
JOSEPH A. ANDREWS, M.D. . . . .	NEW YORK CITY, N.Y., U.S.A.
JOSEPH McFARLAND, M.D. . . . .	PHILADELPHIA, PA., U.S.A.
SAMUEL STRYKER KNEASS, M.D. . . . .	PHILADELPHIA, PA., U.S.A.
CHARLES STEDMAN BULL, A.M., M.D. . . . .	NEW YORK CITY, N.Y., U.S.A.
GEORGE C. HARLAN, A.M., M.D. . . . .	PHILADELPHIA, PA., U.S.A.
SAMUEL THEOBALD, M.D. . . . .	BALTIMORE, MD., U.S.A.
EDMUND LANDOLT, M.D. . . . .	PARIS, FRANCE.
SWAN M. BURNETT, M.D., PH.D. . . . .	WASHINGTON, D.C., U.S.A.
J. P. NUEL, M.D. . . . .	LIÈGE, BELGIUM.
W. A. BRAILEY, M.A., M.D. (Cambridge) . . . . .	LONDON, ENGLAND.
SYDNEY STEPHENSON, M.B. . . . .	LONDON, ENGLAND.
CHARLES A. OLIVER, A.M., M.D. . . . .	PHILADELPHIA, PA., U.S.A.
WILLIAM F. NORRIS, A.M., M.D. . . . .	PHILADELPHIA, PA., U.S.A.
A. HILL GRIFFITH, M.D. (Aberd.) . . . . .	MANCHESTER, ENGLAND.
ISIDOR SCHNABEL, M.D. . . . .	VIENNA, AUSTRIA.
JOSEPH SCHÖBL, M.D. . . . .	PRAGUE, AUSTRIA.
JOHANN DEYL, M.D. . . . .	PRAGUE, AUSTRIA.
PRIESTLEY SMITH, Esq. . . . .	BIRMINGHAM, ENGLAND.
EMIL GRUENING, M.D. . . . .	NEW YORK CITY, N.Y., U.S.A.
ROBERT L. RANDOLPH, M.D. . . . .	BALTIMORE, MD., U.S.A.
HERMAN KNAPP, M.D. . . . .	NEW YORK CITY, N.Y., U.S.A.
O. HAAB, M.D. . . . .	ZÜRICH, SWITZERLAND.
HENRY R. SWANZY, A.M., M.B., F.R.C.S.I. . . . .	DUBLIN, IRELAND.
J. B. LAWFORD, Esq. . . . .	LONDON, ENGLAND.
JOHN B. STORY, M.B., F.R.C.S.I. . . . .	DUBLIN, IRELAND.
J. SANTOS-FERNANDEZ, M.D. . . . .	HAVANA, CUBA.
M. PARINAUD, M.D. . . . .	PARIS, FRANCE.
JONATHAN HUTCHINSON, JR., Esq. . . . .	LONDON, ENGLAND.
MYLES STANDISH, A.M., M.D. . . . .	BOSTON, MASS., U.S.A.
GEORGE E. DE SCHWEINITZ, A.M., M.D. . . . .	PHILADELPHIA, PA., U.S.A.
MAXIMILIAN SALZMANN, M.D. . . . .	VIENNA, AUSTRIA.
A. GAYET, M.D. . . . .	LYONS, FRANCE.

# CONTENTS.

## VOLUME I.

### Embryology, Anatomy, and Physiology of the Eye.

#### DEVELOPMENT OF THE EYE.

John A. Ryder, Ph.D. . . . . Philadelphia, Pa., U.S.A.  
Professor of Comparative Embryology in the University of Pennsylvania.

#### THE ANATOMY OF THE ORBIT AND THE APPENDAGES OF THE EYE.

Thomas Dwight, M.D., LL.D. . . . . Boston, Mass., U.S.A.  
Parkman Professor of Anatomy at Harvard University.

#### THE ANATOMY OF THE EYEBALL AND OF THE INTRA-ORBITAL PORTION OF THE OPTIC NERVE.

Frank Baker, M.D., Ph.D. . . . . Washington, D.C., U.S.A.  
Professor of Anatomy in the University of Georgetown; Honorary Curator of Anatomy in the U.S. National Museum.

#### THE MICROSCOPICAL ANATOMY OF THE EYEBALL.

George A. Piersol, M.D. . . . . Philadelphia, Pa., U.S.A.  
Professor of Anatomy in the University of Pennsylvania.

#### ANATOMY OF THE INTRA-CRANIAL PORTION OF THE VISUAL APPARATUS.

Alex Hill, M.A., M.D. . . . . Cambridge, England.  
Master of Downing College; late Hunterian Professor at the Royal College of Surgeons of England.

#### CONGENITAL MALFORMATIONS AND ABNORMALITIES OF THE HUMAN EYE.

William Lang, F.R.C.S.E. . . . . London, England.  
Surgeon to the Royal London Ophthalmic Hospital; Ophthalmic Surgeon to and Lecturer on Ophthalmology at the Middlesex Hospital.

E. Treacher Collins, F.R.C.S.E. . . . . London, England.  
Curator and Librarian to the Royal London Ophthalmic Hospital.

#### THE DIOPTRICS OF THE EYE.

Edward Jackson, A.M., M.D. . . . . Philadelphia, Pa., U.S.A.  
Professor of Diseases of the Eye in the Philadelphia Polyclinic; Special Lecturer on Physiological Optics in the University of Colorado.

#### THE PERCEPTION OF LIGHT.

J. McKeen Cattell, M.A., Ph.D. . . . . New York City, N.Y., U.S.A.  
Professor of Experimental Psychology in Columbia College.

#### BINOCULAR VISION, CONFLICT OF THE FIELDS OF VISION, APPARENT AND NATURAL SIZE OF OBJECTS, ETC.

Eugen Brodhun, M.D. . . . . Berlin, Germany.  
Assistant in the Frederick William University.

Translated by Christine Ladd Franklin . . . . . Baltimore, Md., U.S.A.

#### NORMAL COLOR-PERCEPTION.

William Thomson, M.D. . . . . Philadelphia, Pa., U.S.A.  
Professor of Ophthalmology in the Jefferson Medical College; Attending Surgeon to the Wills Eye Hospital.

Assisted by Carl Weiland, M.D. . . . . Philadelphia, Pa., U.S.A.  
Clinical Assistant in the Eye Department of the Jefferson Medical College Hospital.

#### PHOTO-CHEMISTRY OF THE RETINA.

Carl Mays, M.D. . . . . Heidelberg, Germany.  
Assistant in the Physiological Laboratory of Heidelberg.

Translated by James A. Spalding, A.M., M.D. . . . . Portland, Me., U.S.A.  
Ophthalmic Surgeon to the Maine Eye and Ear Infirmary, and to the Maine General Hospital.

## VOLUME II.

### Examination of the Eye, School Hygiene, Statistics of Blindness, and Antisepsis.

#### ON THE METHODS OF DETERMINING THE ACUITY OF VISION.

Herman Snellen, M.D. . . . . Utrecht, Holland.  
Professor of Ophthalmology in the University of Utrecht.

Translated by George A. Berry, M.B., F.R.C.S. Ed. . . . . Edinburgh, Scotland.  
Lecturer on Ophthalmology in the University of Edinburgh.

**MYDRIATICS AND MYOTICS.**

Herman Snellen, Jr., M.D. . . . . Utrecht, Holland.  
Ophthalmic Surgeon to the Netherlands Hospital.

**LATERAL ILLUMINATION.**

L. Laqueur, M.D. . . . . Strassburg in Alsace, Germany.  
Professor of Ophthalmology and Director of the Ophthalmological Clinic in the University of Strassburg.

Translated by Harry Friedenwald, A.B., M.D. . . . . Baltimore, Md., U.S.A.  
Associate Professor of Ophthalmology and Otolaryngology, College of Physicians and Surgeons; Ophthalmic and Aural Surgeon to the Baltimore City Hospital.

**THE OPHTHALMOSCOPE AND THE ART OF OPHTHALMOSCOPY.**

George M. Gould, A.M., M.D. . . . . Philadelphia, Pa., U.S.A.  
Late Ophthalmologist to the Philadelphia Hospital.

**SKIASCOPY (THE SHADOW-TEST, RETINOSCOPY) AND ITS PRACTICAL APPLICATION.**

Edward Jackson, A.M., M.D. . . . . Philadelphia, Pa., U.S.A.  
Professor of Diseases of the Eye in the Philadelphia Polyclinic; Attending Surgeon to the Wills Eye Hospital.

**OPHTHALMOMETRY AND ITS CLINICAL APPLICATIONS.**

Adolphe Javal, Jr. . . . . Paris, France.  
(Translated.)

**PRISMS AND PRISMOMETRY.**

William S. Dennett, A.M., M.D. . . . . New York City, N.Y., U.S.A.  
Surgeon to the New York Eye and Ear Infirmary.

**THE PRINCIPLES OF AND THE METHODS FOR THE ESTIMATION OF THE BALANCE OF THE EXTRA-OCULAR MUSCLES.**

George T. Stevens, M.D., Ph.D. . . . . New York City, N.Y., U.S.A.

**PERIMETRY AND ITS CLINICAL VALUE.**

Herman Wilbrand, M.D. . . . . Hamburg, Germany.  
Ophthalmic Surgeon to the General Hospital of Hamburg.

Translated by Thomas R. Pooley, M.D. . . . . New York City, N.Y., U.S.A.  
Formerly Professor of Ophthalmology in the New York Polyclinic; Surgeon to the New Amsterdam Eye and Ear Hospital.

**DETECTION OF COLOR-BLINDNESS.**

William Thomson, M.D. . . . . Philadelphia, Pa., U.S.A.  
Professor of Ophthalmology in the Jefferson Medical College; Attending Surgeon to the Wills Eye Hospital.

Assisted by Carl Weiland, M.D. . . . . Philadelphia, Pa., U.S.A.  
Chief Clinical Assistant, Eye Department, Jefferson Medical College Hospital.

**SCHOOL HYGIENE.**

Samuel D. Risley, A.M., M.D., Ph.D. . . . . Philadelphia, Pa., U.S.A.  
Professor of Ophthalmology in the Philadelphia Polyclinic and College for Graduates in Medicine; Attending Surgeon to the Wills Eye Hospital.

**BLINDNESS: ITS FREQUENCY, CAUSES, AND PREVENTION.**

I. Minis Hays, A.M., M.D. . . . . Philadelphia, Pa., U.S.A.

**ANTISEPSIS.**

Joseph A. Andrews, M.D. . . . . New York City, N.Y., U.S.A.  
Ophthalmic Surgeon to the Charity Hospital.

**THE MICRO-ORGANISMS OF THE CONJUNCTIVA AND LACRYMAL SAC.**

Joseph McFarland, M.D. . . . . Philadelphia, Pa., U.S.A.  
Demonstrator of Pathological Histology in the University of Pennsylvania; Adjunct Professor of Pathology in the Philadelphia Polyclinic and College for Graduates in Medicine.

Samuel Stryker Kneass, M.D. . . . . Philadelphia, Pa., U.S.A.  
Adjunct Professor of Bacteriology in the Philadelphia Polyclinic and College for Graduates in Medicine.

---

**VOLUME III.**  
**Local Diseases of the Eye.**

**DISEASES OF THE ORBIT.**

Charles Stedman Bull, A.M., M.D. . . . . New York City, N.Y., U.S.A.  
Professor of Ophthalmology in the University of the City of New York; Surgeon to the New York Eye and Ear Infirmary.



## DISEASES OF THE EYELIDS.

George C. Harlan, A.M., M.D. . . . . Philadelphia, Pa., U.S.A.  
Surgeon to the Wills Eye Hospital, and to the Eye and Ear Department of the Pennsylvania Hospital.

## DISEASES OF THE LACRYMAL APPARATUS.

Samuel Theobald, M.D. . . . . Baltimore, Md., U.S.A.  
Clinical Professor of Ophthalmology in the Johns Hopkins University; Ophthalmic and Aural Surgeon to the Johns Hopkins Hospital.

## THE ANOMALIES OF THE MOTOR APPARATUS OF THE EYE.

Edmund Landolt, M.D. . . . . Paris, France.  
Translated by C. M. Culver, A.M., M.D. . . . . Albany, N.Y., U.S.A.  
Ophthalmic Surgeon to the Albany Orphan Asylum.

## DISEASES OF THE CONJUNCTIVA.

Swan M. Burnett, M.D., Ph.D. . . . . Washington, D.C., U.S.A.  
Professor of Ophthalmology and Otology in the University of Georgetown; Director of the Eye and Ear Clinic at the Emergency Hospital.

## DISEASES OF THE CORNEA.

J. P. Nuel, M.D. . . . . Liège, Belgium.  
Professor of Ophthalmology in the University of Liège.

Translated by Thomas H. Fenton, M.D. . . . . Philadelphia, Pa., U.S.A.  
Medical Director and Senior Ophthalmic Surgeon to the Union Mission Hospital.

## DISEASES OF THE IRIS AND CILIARY BODY.

W. A. Brailey, M.A., M.D. (Cambridge) . . . . London, England.  
Assistant Ophthalmic Surgeon to Guy's Hospital; Ophthalmic Surgeon to the Evelina Hospital for Children.

Sydney Stephenson, M.B., F.R.C.S. Ed. . . . . London, England.  
Surgeon to the Ophthalmic School, Hanwell, W.

## ERRORS OF REFRACTION: ETIOLOGY, COURSE, AND TREATMENT.

Charles A. Oliver, A.M., M.D. . . . . Philadelphia, Pa., U.S.A.  
One of the Attending Surgeons to Wills Eye Hospital; one of the Ophthalmic Surgeons to the Philadelphia Hospital.

## DISEASES OF THE LENS.

William F. Norris, A.M., M.D. . . . . Philadelphia, Pa., U.S.A.  
Professor of Ophthalmology in the University of Pennsylvania; one of the Attending Surgeons to Wills Eye Hospital.

## DISEASES OF THE CHORIOID AND VITREOUS.

A. Hill Griffith, M.D. (Aberd.), F.R.C.S. Ed. . . . . Manchester, England.  
Honorary Surgeon to the Royal Eye Hospital.

## THE ANATOMY OF STAPHYLOMA POSTICUM AND THE RELATIONSHIP OF THE CONDITION TO MYOPIA.

Isidor Schnabel, M.D. . . . . Vienna, Austria.  
O. O. Professor of Ophthalmology in the University of Vienna.

Translated by Charles H. Reed, M.D. . . . . Philadelphia, Pa., U.S.A.

## DISEASES OF THE RETINA.

Joseph Schöbl, M.D. . . . . Prague, Austria.  
Professor of Ophthalmology in the University of Prague.

Translated by Adolf Alt, M.D., M.C.P. and S. (Ont.) . . . . St. Louis, Mo., U.S.A.  
Professor of Ophthalmology and Otology in the Beaumont Hospital Medical College; Consulting Oculist to the Northern Pacific Railway System.

## DISEASES OF THE OPTIC NERVE.

Johann Deyl, M.D. . . . . Prague, Austria.  
Professor of Ophthalmology in the Royal Bohemian Polyclinic.

Translated by Robert Sattler, M.D. . . . . Cincinnati, Ohio, U.S.A.

## GLAUCOMA: PATHOGENESIS, SYMPTOMS, COURSE, AND TREATMENT.

Priestley Smith, Esq. . . . . Birmingham, England.  
Ophthalmic Surgeon to the Queen's Hospital; Lecturer on Ophthalmology in the Queen's Faculty of Medicine, Mason College.

## WOUNDS AND INJURIES OF THE EYEBALL AND ITS APPENDAGES.

Emil Gruening, M.D. . . . . New York City, N.Y., U.S.A.  
Professor of Ophthalmology in the New York Polyclinic; Ophthalmic Surgeon to the New York Eye and Ear Infirmary.

## SYMPATHETIC IRRITATION AND SYMPATHETIC INFLAMMATION.

Robert L. Randolph, M.D. . . . . Baltimore, Md., U.S.A.  
Associate in Ophthalmology and Otology, Johns Hopkins University, and Associate Ophthalmic and Aural Surgeon to the Johns Hopkins Hospital.

## A DESCRIPTION OF THE OPERATIONS USUALLY PRACTISED IN EYE SURGERY.

Herman Knapp, M.D. . . . . New York City, N.Y., U.S.A.  
Professor of Ophthalmology in the College of Physicians and Surgeons; Surgeon to the New York Ophthalmic and Aural Institute.

VOLUME IV.  
Medical Ophthalmology.

OCULAR LESIONS DEPENDENT UPON DISEASES IN THE CIRCULATORY SYSTEM (GENERAL AND PERNICIOUS ANÆMIA, LEUCOCYTHÆMIA, CARDIAC AFFECTIONS, THROMBOSIS, EMBOLISM, PERIVASCULITIS, ENDARTERITIS, RECURRENT RETINAL HEMORRHAGE IN ADOLESCENTS, ETC.).

O. Haab, M.D. . . . . Zürich, Switzerland.  
Professor in the University of Zürich, and Director of the Eye-Clinic at Zürich.  
Translated by William Zentmayer, M.D. . . . . Philadelphia, Pa., U.S.A.  
Assistant Surgeon to Wills Eye Hospital; Ophthalmic Surgeon to St. Mary's Hospital.

SENSORY AND MOTOR OCULAR CHANGES RESULTING FROM LESIONS OF THE BRAIN AND SPINAL CORD.

Henry R. Swanzy, A.M., M.B., F.R.C.S.I. . . . . Dublin, Ireland.  
Surgeon to the National Eye and Ear Infirmary; Ophthalmic Surgeon to the Adelaide Hospital.

OCULAR LESIONS DEPENDENT UPON DISORDERS TAKING THEIR ORIGIN IN THE SECRETORY AND EXCRETORY SYSTEMS.

J. B. Lawford, Esq. . . . . London, England.  
Ophthalmic Surgeon to St. Thomas's Hospital; Surgeon to the Royal London Ophthalmic Hospital.

OCULAR LESIONS IN SPECIAL DYSCRASIÆ (VARIOLA, RUBEOLA, SCARLATINA, ERYSIPELAS, RELAPSING TYPHUS FEVER, ETC.).

John B. Story, M.B., F.R.C.S.I. . . . . Dublin, Ireland.  
Surgeon to St. Mark's Ophthalmic Hospital; Professor of Ophthalmology in the Royal College of Surgeons, Ireland.

OCULAR LESIONS IN SPECIAL DYSCRASIÆ (INFLUENZA, DYSENTERY, CHOLERA, MALARIAL FEVER, DENGUE, YELLOW FEVER, ETC.).

J. Santos-Fernandez, M.D. . . . . Havana, Cuba.  
Director of the Histo-Bacteriological Laboratory of the Crónica Médico-Quirúrgica.  
Translated by Daniel Guitéras, M.D.  
Passed Assistant Surgeon, U. S. Navy.

EYE AFFECTIONS DUE TO HYSTERIA.

M. Parinaud, M.D. . . . . Paris, France.  
Senior Chief of the Ophthalmological Service of the Salpêtrière Hospital.  
Translated by Casey A. Wood, M.C., M.D. . . . . Chicago, Ill., U.S.A.  
Professor of Ophthalmology in the Post-Graduate Medical School; Ophthalmic Surgeon to the Cook County Hospital.

EYE AFFECTIONS DUE TO GRAVES'S DISEASE AND HERPES ZOSTER.

Jonathan Hutchinson, Jr., Esq. . . . . London, England.  
Assistant Surgeon to the London Hospital.

MOTOR CHANGES IN THE OCULAR APPARATUS ASSOCIATED WITH FUNCTIONAL NEUROSES.

Myles Standish, A.M., M.D. . . . . Boston, Mass., U.S.A.  
Ophthalmic Surgeon to the Massachusetts Charitable Eye and Ear Infirmary; Assistant in Ophthalmology in the Harvard Medical School.

TOXIC AMBLYOPIAS.

George E. de Schweinitz, A.M., M.D. . . . . Philadelphia, Pa., U.S.A.  
Professor of Ophthalmology in the Jefferson Medical College; Ophthalmic Surgeon to the Philadelphia Hospital.

PARASITES OF THE HUMAN EYE.

Maximilian Salzmann, M.D. . . . . Vienna, Austria.  
First Assistant in Professor Fuchs's Eye Clinic, Vienna, Austria.  
Translated by H. V. Würdemann, M.D. . . . . Milwaukee, Wis., U.S.A.  
Director and Secretary, Wisconsin General Hospital Association; Oculist and Aurist to the Children's Hospital.

OCULAR SIGNS OF DEATH.

A. Gayet, M.D. . . . . Lyons, France.  
Professor of Ophthalmology and Chief Ex-Surgeon to the Hôtel-Dieu.  
Translated by E. C. Ellett, M.D. . . . . Memphis, Tenn., U.S.A.  
Ophthalmic Surgeon to St. Joseph's Hospital; Consulting Ophthalmologist to the City Hospital.







