

Digitized by the Internet Archive
in 2018 with funding from
Getty Research Institute



Keep the Doors of Memory Open with an Ansco

*Pictures always tell a story
better and quicker than words*

THAT is why amateur photography has made such a strong appeal to people of all ages, in every land and clime. The love of pictures lives in every heart—the desire to perpetuate in memory the dear days that are gone is a fundamental instinct of the race. The taking of pictures is in itself a pleasant and instructive pastime. The recording of the unusual events of life by means of a photograph constitutes a real investment in happiness for the days to come.

In selecting a camera, therefore, careful thought as to the *results* in prospect must be taken, and the camera chosen which will do the things you want it to do.

ANSCO
Pocket
Photog-
raphy

ANSCO Vest-Pocket cameras stand today at the pinnacle of photographic success. There are no V-P cameras made that can equal them in appearance, workmanship, compactness and efficiency. They are in a class by themselves — cameras of distinction in style, equipment and photographic capability.

Literally, the ANSCO V-P is the successor to the pocket diary, because pictures tell a story so much better and quicker than words that the ANSCO has become the great recorder of interesting deeds and scenes and events for thousands of people throughout the world. It is so small, so flat, that it can be slipped into vest, coat or hip pocket, ready for instant use—you can carry it with you always.

The models described in the succeeding two pages are fitted with anastigmat lenses and are as accurate in action as a fine jeweled watch. They are made fully effective through easily operated devices for quick and accurate focusing.

ANSCO V-P pictures are so clear and sharp that they can be enlarged successfully. The cameras are inexpensive as an investment, economical in operation and extremely satisfactory in service.

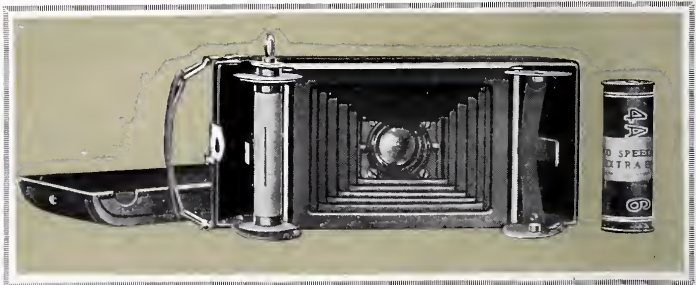

ANSCO
V-P
No. 0
(Focusing
model)



Size of picture	V-P No. 0	Specifications
Size of film	$1\frac{5}{8} \times 2\frac{1}{2}$	
Dimensions	2C	
Weight	$1 \times 2\frac{1}{2} \times 5$	
Focal length of lens	$10\frac{1}{2}$ oz.	
Price, Modico Anastigmat, F 7.5, Extraspeed Bionic shutter	$3\frac{3}{8}$ in.	
War Tax	\$18.75	
ANSCO Anastigmat, F 6.3, Extraspeed Bionic shutter ..	1.25	
War Tax	26.50	
War Tax	1.77	
<hr/>		
Sole leather holster, black or tan, with shoulder strap	\$3.00	Extras
Carrying case	1.25	
ANSCO Direct View-Finder	2.50	
ANSCO Portrait Attachment50	
Eight-exposure film (2C)20	
War Tax01	

The foregoing prices are subject to change without notice

ANSCO COMPANY, BINGHAMTON, N. Y.

ANSCO
V-P
No. 2



Specifications

Size of picture	2¼ x 3¼	V-P No. 2
Size of film	4A	
Dimensions	1¼ x 2⅞ x 6½	
Weight	19 oz.	
Focal length of lens	3½ in.	
Price, Modico Anastigmat lens, F 7.5, Extraspeed Bionic shutter	\$25.00	
<i>War Tax</i>	1.67	
AnSCO Anastigmat lens, F 6.3, Extraspeed Bionic shutter ..	30.00	
<i>War Tax</i>	2.00	

Extras

Sole leather holster, black or tan, with shoulder strap.....	\$4.00
Carrying case, with shoulder strap.....	1.50
ANSCO Direct View-Finder.....	2.50
ANSCO Portrait Attachment50
Six-exposure film (4A)20
<i>War Tax</i>01

The foregoing prices are subject to change without notice

ANSCO COMPANY, BINGHAMTON, N. Y.

The ROYAL FOREGROUND GRADED FILTER

(Patented April 14th, 1911)

The Latest and Greatest Improvement in Ray Filters

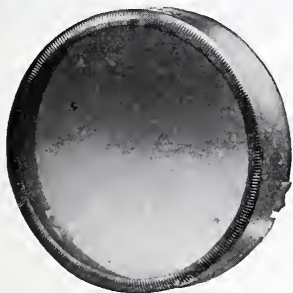

STYLE A.

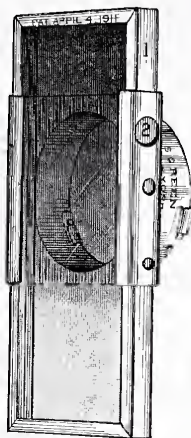

STYLE B.

The only Ray Screen ever invented that will give an even, equal exposure to both sky and foreground, and produce a perfect cloud effect instantaneously with ordinary plates.

The Royal Foreground Ray Screen is so constructed that the color, which is a strong orange yellow at the top, is gradually diminished until perfect transparency is attained at the bottom. The practical effect of the gradual blending of color is to sift out or absorb the powerful chemical rays from the clouds and sky, which pass through the strongly colored top of the filter, without perceptibly decreasing the weak illumination of the reflected light from the foreground, which comes through the transparent or colorless lower part of the screen in full intensity.

The reason that daylight cloud pictures are rare is that the strength of the illumination from the sky is many, many times that of the partially absorbed and reflected light from objects on the ground.

If a correct exposure is given to the clouds, then the landscape is badly under-exposed; if the correct exposure is given to the landscape, then the clouds are literally burnt up from over-exposure, and no matter how contrasty they may have appeared to the eye, an unscreened photograph shows only a blank white sky.

The Royal Foreground Ray Screen is also very useful for subjects which are more strongly illuminated on one side than on the other, as in photographing by the light of a side window or in a narrow street. By simply turning the dark side of the foreground screen toward the bright side of the object a good, even exposure will result.

Style A slips over the front of the lens the same as a lens cap, and may be instantly attached or removed.

No.	Dia. ins.	Price
0 A	$\frac{7}{8}$	\$1.50
1 A	1 $\frac{5}{16}$	1.50
2 A	for box cam.	1.50
3 A	1 $\frac{7}{16}$	1.50
4 A	1 $\frac{1}{2}$	1.50
5 A	1 $\frac{3}{4}$	2.00
6 A	2	2.25
7 A	2 $\frac{1}{4}$	2.50
8 A	2 $\frac{1}{2}$	3.00
9 A	2 $\frac{3}{4}$	3.25
10 A	3	3.50
11 A	3 $\frac{1}{4}$	4.00
12 A	3 $\frac{1}{2}$	4.50
13 A	4	5.25
14 A	4 $\frac{1}{2}$	6.00

Style B is mounted in a sliding frame so as to bring a filter of any desired depth of color in front of the camera lens.

No.	Dia. ins.	Price
1 B	1 $\frac{5}{16}$	\$3.00
3 B	1 $\frac{7}{16}$	3.00
4 B	1 $\frac{1}{2}$	3.00
5 B	1 $\frac{3}{4}$	4.00
6 B	2	4.50
7 B	2 $\frac{1}{4}$	5.00
8 B	2 $\frac{1}{2}$	6.00
9 B	2 $\frac{3}{4}$	6.50
10 B	3	7.00
11 B	3 $\frac{1}{4}$	8.00
12 B	3 $\frac{1}{2}$	9.00
13 B	4	10.50
14 B	4 $\frac{1}{2}$	12.00

GEORGE MURPHY, Inc.

57 East Ninth Street

NEW YORK

When you need practical help and live information on any branch of photographic work, ask your dealer for

THE PHOTO-MINIATURE

dealing with the special subject on which you need information

A Series of Handbooks on Practical Photography

- ¶ Edited by John A. Tennant, for the man who wants the plain facts about one thing at a time; crisply put and made interesting. Practical, comprehensive; never tedious or long winded.
- ¶ Each number is a complete book—often the only book—on its subject. Always the most useful book on the subject, regardless of price. Packed with facts; self-indexing for quick reference.
- ¶ Every number deals with a different subject and tells all worth knowing about that subject. Direct information, from practical experience. Written by men who know how and why. Illustrated.

Per Copy 40 Cents, Per Year \$4.00

SEE THE BOOKS AT YOUR DEALERS

or write the publishers for complete list of titles.

PHOTOGRAMS OF THE YEAR

A Pictorial Review of the Best Pictures of the Year. Published annually in February.

PHOTOGRAPHING FLOWERS AND TREES

By J. Horace McFarland. The only book on this profitable field of work. 93 pages; 70 illustrations. 50 cents postpaid.

PRACTICAL PRINCIPLES OF PLAIN PHOTO-MICROGRAPHY

By George West. The best common-sense introduction to this subject in the language. 160 pages; 8 full page plates. \$2.50 postpaid.

PENROSE'S PICTORIAL ANNUAL PROCESS WORKERS YEAR BOOK

A new volume will be ready in February.

Send to us for any photographic book.

TENNANT & WARD, PUBLISHERS

103 PARK AVE., NEW YORK



Photographs of Character

distinctive in tone and quality, can only be obtained by the use of a lens of correct formula and expert workmanship.

Quality is dominant in Wollensak Lenses



There is "a lens for every purpose" among them the well-known "VELOSTIGMAT" anastigmats, "VERITO," for pictorialist and artist photographer, and "VI-TAX" for portraiture.



Our 1920 catalogue will tell you more about them. A card will bring a copy.

WOLLENSAK OPTICAL CO.
Rochester,
N.Y.

NEW ROSS LENSES

Cover Perfectly with Brilliant Definition and Are Extremely Rapid. Adaptable to All Modern Cameras.

ROSS' New "XPRES" PATENT



Working at full aperture.
For Studio Portraits and Groups and for all work requiring extreme rapidity.
Exceptionally Brilliant.
Definition to margins.

F/4-5

Full Aperture

12-inch "XPRES" THE LENS
for Cabinets and Whole-plate Groups.
Admirable for Reflex and Hand Cameras.

F/4-5

ROSS' New "TELECENTRIC" Patent

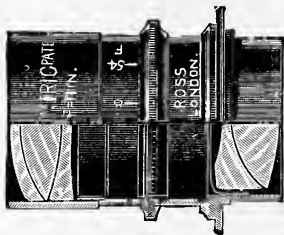

Large Image with Short Camera Extension.
Critical Definition at full aperture.
Shortened Exposures Ideal for Sporting Events.
Inexpensive Studio Lens.
Covering to margins.

F/5-4

Two Series

F/6-8

ROSS' New "COMBINABLES" Patent

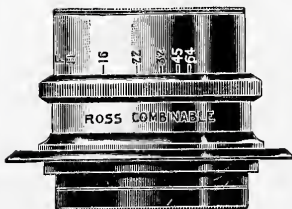

F/11

Singles and Doublets

F/5-5

The Singles are the most Rapid Single Anastigmats, perfectly corrected, giving Critical Definition to the margins without distortion—For Landscapes, Large Portraits, and Groups. The Universal Doublets are specially suitable for Portraits and Groups in the Studio and all outdoor Photography, Interiors, Copying, etc.

For Full Particulars see Ross' New Price List, sent free on Application.

American Agents

GEORGE MURPHY, Inc.

57 East Ninth Street

NEW YORK

This Is the New Model Ruby Reflex

Thornton—Pickard—England

A Marvel of Scientific Camera Construction



The Ruby Reflex Camera has a highly perfected focal plane shutter with safety curtain. One turn of a knob sets the shutter for any exposure, automatically adjusts the exposure slit and sets the safety blind. Speed from 1/10 to 1/1000 of a second. Has revolving back and double bellows extension. All New Model Ruby Reflex Cameras are fitted with the world famous COOKE F 4.5 LENSES. Descriptive circular on request. At your dealer's.

Price: $2\frac{1}{4} \times 3\frac{1}{4}$ \$100
 $3\frac{1}{4} \times 4\frac{1}{4}$ \$120 4×5 \$150

WILLOUGHBY'S

110 West 32d Street, New York

U. S. A. Sales Agents

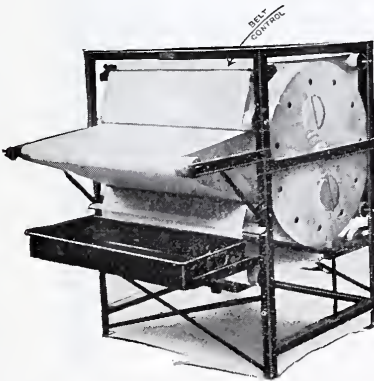

WHAT YOU NEED

to complete your
Finishing Department

Simplex Dryer WITH BELT CONTROL dries prints faster than any other method known.

DUPLEX W A S H E R WITH AUTO LIFT works without water pressure.

No need to put hands in water.

Send for Circulars to

Simplex Photo Specialty Co.

505 Fifth Avenue
New York, N. Y., U. S. A.

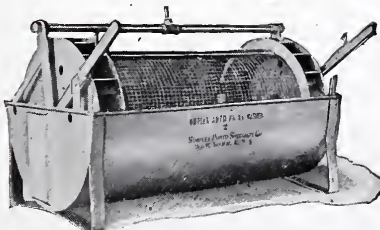

The Presto Duplex Printing Machines

Type B

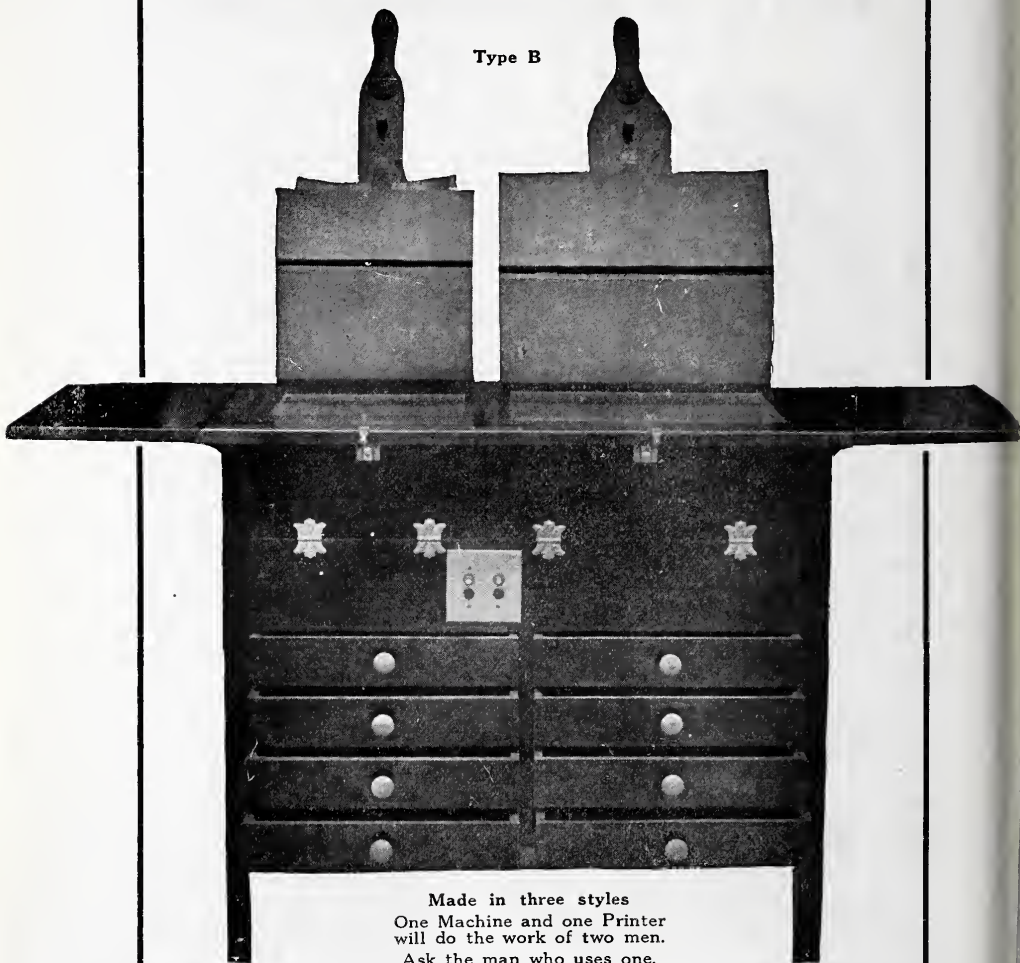

Made in three styles
One Machine and one Printer
will do the work of two men.
Ask the man who uses one.

Other Specialties

The Infallible Tinting Masks

Presto Studio Mirror

Presto Embosser

Free catalogue upon request.

PRESTO MFG. CO.

5125 Coral Street

Pittsburgh, Pa.

GOERZ LENSES

Are Still Unsurpassed

GOERZ LENSES may be fitted to practically all standard cameras that are well constructed, and will, in every instance, greatly increase the efficiency of the photographer's equipment. We are always glad to furnish full information *as to the best lens* that can be fitted to each of the various camera models on the market. If you already have a camera fitted with an old type rectilinear lens, you can improve your photographic work considerably by having us fit a high-grade GOERZ ANASTIGMAT Lens to your equipment. If you wish to buy a complete new outfit, write us about *your specific requirements* and we will gladly suggest the best lens, shutter and camera combination for your work.

Our descriptive matter is of unusual interest and practical value. Sample prints are yours for the asking.

Write for same today. A postal will do.

**C. P. Goerz American Optical
Company**

OFFICE AND FACTORY:

317K East 34th St., New York City

BASS
CAMERA COMPANY

Camera Headquarters of the World

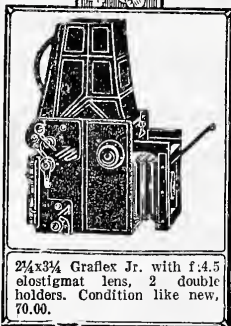

24x34 Graflex Jr. with f:4.5
elostigmat lens. 2 double
holders. Condition like new,
70.00.

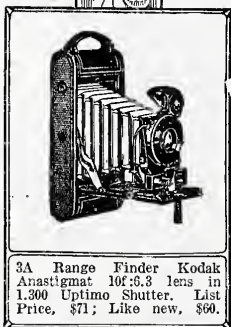

3A Range Finder Kodak
Anastigmat 10f:6.3 lens in
1.300 Uptimo Shutter. List
Price, \$71; Like new, \$60.

High grade New and Used Cam-
eras, Outfits and Lenses—Also
Motion Picture Cameras and
Projectors—at extremely low
prices—shipped everywhere and
backed by the Bass guarantee.

The Bass Camera Company is well known to
travelers, sportsmen, educators, professional
photographers and photographic enthusiasts in
every quarter of the globe.

We believe we have the largest selection of
high grade photographic equipment and
Motion Picture Cameras in the world. Lo-
cated in Chicago U. S. A.—the great Central
Market—We are in a strategic position to
secure and ship the finest apparatus—and
to sell at unheard of low prices.

Regardless of your requirements, write us
and let us quote you our price for exactly
what you want. Or send for our newest cata-
log and bulletin, as well as our Motion Picture
Camera Catalog. All or any sent gratis.

Fair exchanges or fair prices offered for your
present equipment. Send description.

We equip expeditions, schools, laboratories,
studios, Motion Picture Cameramen. Our
growth is due to the confidence our patrons
have in our ability to give full value and
complete satisfaction.

*At least write us, that we may place your name on our
mailing list to receive our regular bulletins of Camera and
Equipment Bargains.*

BASS CAMERA COMPANY
109 N. DEARBORN ST. ^{Dept} 119 **CHICAGO U.S.A.**

WHEN YOU CHOOSE A SHUTTER

Choose for Accuracy and Reliability.
That Means the Top Notch of
Satisfaction and You'll get it in an Ilex.

First notice the escapement on the set of gears which controls the slower speeds.

This escapement allows the different exposures to be timed correctly with positive variations of speeds.

Second is the auxiliary speed adjuster which controls the higher speeds, also gives the exact variations. This works independent of the above mentioned set of gears on the high grade Ilex shutters, therefore exact speeds and variations is absolutely assured on every indicated speed, *under any climatic condition or in any position of the camera.*



*Fits all makes
of cameras*

*United States Govern-
ment is using Ilex
Shutters.*

*"Use an Ilex and avoid
shutter trouble."*

*Write for our 1920
Catalogue.*

You will note from the cut that this is a combination of creative genius and mechanical skill which makes the Ilex the only serviceable shutter manufactured.

These are exclusive features originated by this Company and marketed with complete and wonderful success.

At your dealers.

ILEX OPTICAL COMPANY
726 Portland Ave., Rochester, N. Y., U. S. A.

ULRICH'S

Automatic Photo Print Washer (Improved Model)

The Most Practical Print Washer on the Market

To Appreciate it you must see it work.
A Trial and You will not be without it.



U. S. Patent No. 1276289
Aug. 20, 1918

Canadian Patent No. 193706
Nov. 4, 1919

Saves Time and Water. Needs No Water Pressure. Keeps Prints thoroughly separated. Prints removed without getting hands in cold water. Eliminates Hypo from prints in thirty (30) minutes. Syphon overflow takes contaminated water from bottom of tank. BEST MADE and LOWEST PRICED Automatic Print Washer on the market.

Size 12 x 19 x 27..... \$30.00

Size 12 x 19 x 40..... 45.00

(For Sale by All Dealers)

P. D. ULRICH & CO.

33 East Locust St.

Lebanon, Pa.

NOTICE

Due notice is hereby given to dealers in, and users of, infringing print washers, that the U. S. Patent laws as to infringements will be vigorously enforced.

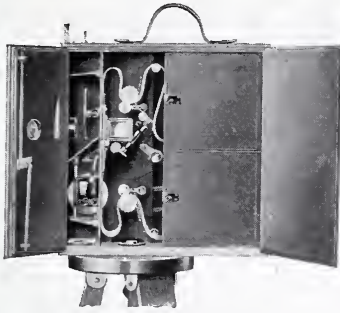

Uses Standard Film
 Has 200 Feet Capacity
 Film Footage Record
 Side Focusing Device
 Brilliant View Finder

BARGAIN PRICE **\$35.00**
 (WITHOUT LENS)

With BAUSCH & LOMB 50 mm.
 Tessar in focusing mount complete F:3.5 **\$58.00**

(With Solid Head Sliding Tripod.....\$5.00 Additional)

A Projection Lens, 2 or 2½ in. Focus, in Focusing Collar,
 for above.....\$3.50

These Motion Picture Cameras were made by a Western firm that sold hundreds of them for \$117.00 each. Manufacturing difficulties, due to the war, made it advisable to discontinue the line and we are closing out the remainder at this remarkably low price. A 2-inch (50 millimeter) lens and this camera give you a practical motion picture outfit.

New York Camera Exchange
 109 FULTON STREET NEW YORK, N. Y.

PHOTOGRAPHIC

PRACTICAL PHOTOGRAPHY

THE aim of the Editors in publishing this series is to give in each volume the practical information needed to master a definite branch of photographic work. Useless, impractical theories are not included, the whole purport of the series being to give up-to-date, usable information that will be immediately helpful in the field or workroom. Illustrations are used wherever necessary to make the text entirely clear but not solely because of their artistic value. Whether in paper or cloth binding, the size will be uniform—handily fitting the pocket. In paper, per copy, 35 cents, or \$3.50 by subscription for twelve numbers. In cloth, per copy, 75 cents, or \$7.50 by subscription for twelve numbers.

No. 1. The Secret of Exposure. If exposure is correct, all other steps in the making of a good negative are purely mechanical. This number discusses exposure thoroughly and gives a complete system, with full directions, for obtaining correct exposure under all conditions, using any plate on the American market.

No. 2. Beginners' Troubles. This number contains an enormous amount of practical help for every worker, novice or expert. Its primary purpose is to show the cause of common failures, but in general it is a manual of photographic work dealing with the production of a perfect negative and a print from it.

No. 3. How to Choose and Use a Lens. Every successful worker must know what his lens can do and how it may be used to best advantage. This number explains the particular qualities of each type of lens now used in photography and deals particularly with the more modern types, their differences and relative advantages.

No. 4. How to Make Prints in Colors. The desirability of making prints in colors led to the publishing of this number, a careful choice of the best methods being made for the guidance of our readers. The toning of a standard black and white print to every possible hue is explained, while the special manipulating processes and the latest developments in natural color photography are clearly described.

No. 5. How to Make Enlargements. No worker who advances beyond the plane of the tyro can produce consistently satisfying results without an enlarger. This volume tells the why of the enlarging process, and follows it with full and clear information regarding the practical side of enlarging, including the construction and use of different types of enlargers.

No. 6. How to Make Portraits. Making portraits in the home is a branch of photography of interest to every owner of a camera. This volume tells in detail how to make portraits of your family and friends, which will be more satisfactory to you than the conventional portrait made in a studio. You need no other source of information than this book to make portraits of any size, by contact or enlarging methods.

No. 7. How to Make Lantern Slides. An exhibit of slides from your own negatives is a treat for your family and friends. In this volume the subject of slide making is thoroughly covered. Slides in black and white, toned, or in natural colors can be made by any camera user. A copy of this book will tell you how to make them.

No. 8. The Elements of Photography. An elementary manual for the beginner, giving a concise but thorough description of the fundamentals of photography with film and plate cameras.

No. 9. Practical Retouching. This manual, designed to cover the whole practice of retouching negatives, combines the practical experience of five skilled workers in this line, each of whom has written exhaustively on the subject. The resulting manuscript covers every phase of the work, including the use of retouching machines.

The books of this series may be had from dealers in photographic supplies, news stands, booksellers or the publishers. Remittance may be made by money order or check.

American Photographic Publishing Co.
264 Pope Building
Boston, Mass.

LITERATURE

Your Success in Photography

EVERY reader of this issue is seriously interested in the success of his photographic efforts. Of this we feel assured—otherwise he would not be reading it to secure information that brings successful results. Information! That is the secret of good results—backed by experience. Information must be up-to-date, authentic, and to be valuable the useless facts must be weeded out from the practical "meaty" matter, and the net result presented to the reader. This is what the Editors are doing in our monthly magazine AMERICAN PHOTOGRAPHY.

For more than thirty years this magazine has served the American photographic public, and endeavored to be all that its name implies—the standard American photographic magazine. It covers the whole field of photography for amateur, professional and commercial workers, publishing each month forceful articles on the best current practice and latest advances in each of these classifications. The monthly departments include two monthly Competitions, with criticism of pictures; "Shop Notes"; "Exchange List," for the exchange of prints; "Reader's Forum," for the general correspondence of readers; "The Market Place," listing the most recent information as to firms buying pictures; "Notes and News" of clubs, new material, books and manufacturing activities. In short, we publish a reader's magazine, and in addition place our Editorial Staff at the service of our friends, to help them with perplexing problems. This means you!

Does a magazine published along such lines meet your ideas of good service? We think it does, for we try to put ourselves in our readers' positions when we consider a change in the makeup of the magazine. Join our steadily increasing circle of readers and friends. The subscription price is but \$2.00 per year, including personal Editorial help when you need it. Send your subscription to-day and look forward to twelve numbers of the best photographic literature that you have ever read.

Optics for Photographers

Translated from the original by HANS HARDING, Ph.D.

By FRANK R. FRAPRIE, S.M., F.R.P.S.

THE writer of this book starts with the fundamental laws of the propagation of light, and carefully and logically carries the reader through the principles of geometrical optics to a complete explanation of the action of all types of photographic lenses, and a description of their qualities and defects. Only the simplest mathematics is used, and this sparingly. The book is brilliantly worked out, and is indispensable in the photographic library, being the only modern and comprehensive work on the subject in English. The author is the calculator and inventor of a well-known series of high-grade anastigmat lenses; he has the happy facility of expressing himself in such clear, simple language that no one will have the least difficulty in understanding his exposition of the subject.

Bound in red cloth, \$2.00

Chemistry for Photographers

WM. R. FLINT.

THIS is the most practical book on photo-chemistry yet published. Before taking up the study of photo-chemistry the author defines, and illustrates with experiments, the basic types of chemical action which are encountered in a study of photo-chemistry. Thus the man who has never studied chemistry is in a position to understand the pages which follow. Subsequently, the reader considers: light and chemical reaction; photo-chemistry of silver salts; the chemistry of development; the chemistry of the fixing process; after-treatment of the negative; printing processes with silver, iron and chromium salts; and the chemicals of photography—every chapter involving a photo-chemical treatment of the subject. *Bound in red cloth, \$2.00*

American Photographic Publishing Co.

264 Pope Building

Boston, Mass.

Check the Product You Desire

SAGAMORE PRODUCTS:

<i>Metol</i>	<i>Amidol</i>
<i>Glycin</i>	<i>Paradel</i>
<i>Saganol</i>	<i>Hydrokinone</i>
<i>Baranol</i>	<i>Pyrogallic Acid</i>

SEND 25 CENTS AND THE NAMES AND ADDRESSES OF FIVE OF YOUR PHOTOGRAPHIC FRIENDS AND WE WILL MAIL YOU A SAMPLE OF ANY ONE OF OUR

American Made Developers

SUFFICIENT FOR A TEST TO PROVE TO YOU THEIR SUPERIOR QUALITIES.

SAGAMORE CHEMICAL CO., Inc.

120-122 West 31st Street, New York

U. S. AGENTS FOR "AGFA" PRODUCTS



"NIAG-RINE"
A NEW KIND OF INDIA INK
ALWAYS READY FOR USE

HAEUSSER'S
TRADE MARK
NIAG-RINE
REGISTERED

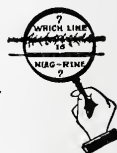

IS AN **INK** ETERNAL
FOR WRITING AND DRAWING

"NIAG-RINE" A Fine, Glossy, Jet Black India Ink, used and recommended by thousands of the best Artists, Draughtsmen, and Writers. Stamp brings free working sample and full particulars. $\frac{1}{2}$ oz. bottle, 15c., 2 oz. 30c., prepaid.

CHAS. HAEUSSER, 20 N. Lawn St., Albany, N. Y.

GRAY'S Parallax Reflecting Condensers

Constant increase in the demand by regular customers—including the U. S. Government—is proof-positive of the value of Parallax for making large photos from small negatives. Ask your dealer.

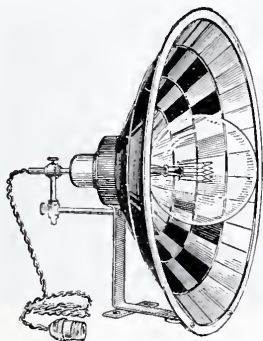

PARALLAX is a Complete Enlarging Condenser, mounted, with adjustable lamp holder and wired socket for incandescent electric lamps. In Series C all of the mirrors are silvered. In Series E white glasses alter-

nate with mirrors through the central rows which equalizes the light over the entire negative. The inch-diameter of a reflector is expressed by its number.

Number and Series	Number of Mirrors	Largest Negative Covered	Largest Nitro Lamp	Price Without Lamp
12E	61	5x7	300 watts	\$10.00
15E	93	7x9	500 "	22.00
19E	98	8x10	1,000 "	30.00
9C	30	4x5	200 "	6.50
11C	30	5x7	200 "	8.50
15C	36	8x10	300 "	15.00
20D	7	Illuminator	1,000 "	22.00

R. D. GRAY, 57 East 9th St., New York
Patentee and Manufacturer

W I S P

(*Art Proof*)

Colors—Brown and Gray



So great has been the demand for this Art Proof Enclosure that we are constantly making up quantity orders in sizes not listed in our catalogue. The stock has the feel of leather and is very durable. The lines are well suited to all pictures.

Size	For Picture	Per 100
46	4 x 6	\$2.75
58	5 x 8	3.50
70	7 x 10	5.50
71	7 x 11	6.50
80	8 x 10	6.50

GEORGE MURPHY, Incorporated

57 East Ninth Street

New York City

Send for Copy of Our New Mount Catalogue



The **KODAK**
ANASTIGMATS
f.7.7 *f.6.3* and *f.4.5*

THE time was when the photographer with a high grade lens used it on several different cameras. Perhaps it had a seven-inch length of focus and was used on a 4x5 plate at its full opening—say, *f.6.3*, and another time did duty as a wide angle on a 5x8 at *f.16*.

These were good lenses and cost a lot of money to make.

The Kodak Anastigmat lenses are made for a specific purpose. They cover the size for which they are listed as well, perhaps better, than any lenses made. But you can not stop them down and use them as wide angle lenses in a larger camera. They are not dual purpose lenses—that's why they cost less to make and why they sell for less.

On the cameras they are listed with, no other lens will give better results—if as good. And ninety-nine people out of a hundred never want to shift them—at least not to a larger camera.

Kodak Anastigmats sell for less because they can't do the things you don't care anything about having them do.

EASTMAN KODAK COMPANY,
ROCHESTER, N. Y.

GRAFLEX

The camera that does the difficult things in photography—and does them well.

It's raining as the ship you have come to welcome home is warping into the dock; the automobile racers are going by your point of vantage at a hundred miles an hour; a quick snap of the ball from the pitcher's box to "first" has caught the runner napping; the children are romping at play on the half-shaded porch—impossible pictures for most cameras, but simple with a Graflex.



The Graflex catalogue—free at your dealer's or by mail—tells you why.

FOLMER & SCHWING DEPARTMENT
EASTMAN KODAK COMPANY
ROCHESTER, N. Y.

Premo Film Packs



QUALITY and convenience—plus the greatest simplicity and rapidity in daylight loading and film changing, are the exceptional advantages of the Premo Film Pack.

..

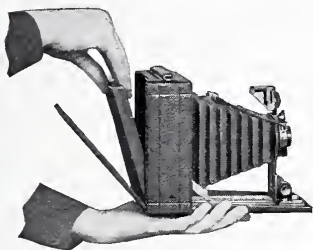

JUST insert the Pack in a Premo Film Pack camera, pull out a paper tab—and you are ready. To change film after exposure, pull out the next numbered paper tab. When the twelfth tab is drawn the Pack is sealed and may be removed in daylight.

..

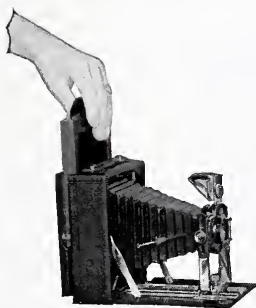

IF you have a plate camera convert it into a film camera with the Premo Film Pack Adapter. The adapter is used in the camera just like a plate holder, but it carries twelve exposures with one loading instead of only two.

*Ask your Kodak dealer for a free copy of
the Premo Catalogue*

ROCHESTER OPTICAL DEPARTMENT
EASTMAN KODAK COMPANY
ROCHESTER, N. Y.

Chemicals have the same bearing on the results you get from sensitive materials as they have in our production of sensitive materials. We use the same care in testing chemicals for your use—for our use. Our interests are identical.

*Use Eastman Tested
Chemicals.*



EASTMAN KODAK COMPANY,
ROCHESTER, N. Y.

All Dealers'.

Brilliance, tone, gradation,
atmosphere—every quality,
every effect you get in the
negative, is retained in the
print on

ARTURA

*The paper without a
disappointment.*



ARTURA DEPARTMENT,
EASTMAN KODAK COMPANY,
ROCHESTER, N. Y.

All Dealers'.

BARGAINS?

Send today for that Big Bargain List
of Used Kodaks, Cameras
and Lenses

ISSUED MONTHLY by

HENRY G. de ROOS

88-3rd Street

San Francisco

The West's Largest Camera Exchange

Made in
U. S. A.

Snow White Fluid

Known
Abroad

THE STANDARD WHITE INK FOR
PHOTOGRAPHERS

Equally serviceable as a white water color or air
brush spray.

Will not rub off
powder nor dis-
color, if given fair
protection by user.



This preparation
is always good.
Simply add water
and stir thoroughly

Most excellent for dark pages of photo albums, dark
surface cards, etc., on titles, signatures; also for
tabulating films, negatives and as a white opaque.

At Better Dealers Generally

Or direct from
New Arts Bldg.

J. W. JOHNSTON
(Dept. A.A.P.)

P. O. Box 578
Rochester, N. Y.

WHEN YOU BUY FLASH POWDER,
GET THE BEST THAT MONEY CAN BUY.



LOOK FOR THE
"PUSSY" ON A
YELLOW LABEL

"The Flash Powder Without a Noise"

THE BEST PROFESSIONAL POWDER ON THE MARKET

3 Grades: Normal, Fast and Very Fast

Very Little Smoke, No Ashes, NO NOISE

Absolutely no danger from friction or concussion. Does not cake or get lumpy. Sold in one and two ounce boxes, and in bulk, at 65c. for ounces, \$1.25 for two oz. boxes and \$9.50 per lb. in bulk. Further information and service can be had from George Murphy, Inc.,

New York; Fowler & Slater, Cleveland; Frank J. Curry, Philadelphia; Atlantic Photo Supply Co., Baltimore; H. Lieber & Co., Indianapolis; L. M. Prince, Cincinnati; Morton & Co., San Francisco; Woodward & Clark Co., Portland, Ore., or

H. J. SINCLAIR, Distributor

319 5th Ave.

Pittsburgh, Pa.

Color Photography—With a Brush

For many years past all the charm of color photography has been available to everyone by the use of

PEERLESS

JAPANESE TRANSPARENT WATER COLORS

The world-famous "self-blending colors"
(Made in U. S. A.)

These photographic colors are the acknowledged standard. They are the original colors put up on films or paper leaflets. They are for sale at all photo supply dealers and art shops. Price lists on application. Illustrated catalog for 2c stamp. For further information address

JAPANESE WATER COLOR COMPANY

Rochester, New York, U. S. A.

Seltona Paper Zeiss Lenses Ica Cameras

J. L. LEWIS, 522 Sixth Avenue, N. Y.

HARVEY EXPOSURE METERS

No. 2 for Kodaks
Graflex and
All Cameras
Exterior or
Interior.
\$2.00



M.P. for
Motion Picture
Cameras
Exterior Work
Only.
\$2.00

Your Dealer or G.L. Harvey 105 So. Dearborn St. Chicago

FORM NO. 32



Gilbert Electric Retoucher

"The Little Speedster"

For Negatives and Prints. Speeds up your retouching. Does expert work. Saves time. Saves money. Costs little to run. Will soon pay for itself. THIS DEVICE gives the "touch" by automatic double vibration produced by an oscillating vibrator. Patented U. S. and Canada. *Geo. G. Holloway* says:

"One of the best inventions Photography has had the good fortune to meet with; most useful."

GILBERT SUPPLY COMPANY, Independence, Iowa



HIGGINS'

PHOTO MOUNTER PASTE and

DRAWING INKS
ETERNAL WRITING INK
ENGROSSING INK
TAURINE MUCILAGE
DRAWING BOARD PASTE
LIQUID PASTE
OFFICE PASTE
VEGETABLE GLUE

Are the Finest and Best Inks and Adhesives

Emancipate yourself from the use of corrosive and ill-smelling inks and adhesives, and adopt the HIGGINS INKS AND ADHESIVES. They will be a revelation to you, they are so sweet, clean, well put-up, and withal so efficient.

At Dealers Generally

Chas. M. Higgins & Co., Mfrs., 271 Ninth Street, Brooklyn, N. Y.

BRANCHES: CHICAGO, LONDON

*The Biggest Photo-
graph Gallery in
all the World—*

Nature

Have you worked in this or do you want to ?

*Send 10c for sample copy
of*

THE GUIDE TO NATURE

Edward F. Bigelow, Editor

ARCADIA

Sound Beach

Connecticut



Earn \$35 to \$100 a Week

BECOME A PROFESSIONAL PHOTOGRAPHER



If you enjoy making photographs—if you have found that you have talent in this line—why not use this talent to full advantage? There are big opportunities NOW for all who have proper training. It takes but a short time to qualify for this fascinating profession. Three months course covers all branches:

MOTION PICTURE — COMMERCIAL — PORTRAITURE
Practical instruction; modern equipment. Day or evening classes; easy terms. No charge for cameras and materials. The School of Recognized Superiority. Call or write for complete catalog.

NEW YORK INSTITUTE OF PHOTOGRAPHY

141 West 36th Street

Department O.

Near Broadway, New York

Study the vibrating quality of

THE STRUSS PICTORIAL LENS

A Pacific Coast Pictorialist writes: "Quality of negatives superb. Full of Vibrating Sunshine. It's a great lens."

KALOGEN—A concentrated liquid universal developer; just add water.

A New England Photo-Finishing House writes: "I have used many different brands of developer, but Kalogen beats them all."

8-oz. bottle, making 200 ozs. normal developer, \$1.25, 16-oz., \$2.00, postpaid.

FRED'K W. KEASBEY, Box 303, Morristown, N. J.

10 Buys
¢100

Millions
Billions
in use
to day



Engel
"Art Corners"

NO PASTE NEEDED

Use them to mount your kodak pictures, post cards, clippings in albums.

Made in Square, Round, Oval, Fancy and Heart shape, of black, gray, sepia and red gummed paper. Slip them on corners of pictures, then wet and stick. **QUICK, EASY, ARTISTIC.** No muss, no fuss. At photo supply, drug and stationery stores. 10 cts. brings full package and samples from

ENGEL MFG. CO., Dept. AA, 1456 Leland Avenue, CHICAGO

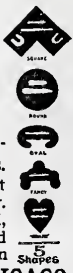

AIR BRUSH

This is the Art Tool that revolutionized picture making the world over.

Those who adapted its use are among the finest picture makers.

Saves Time, and Does Better Work

Address

AIR BRUSH MFG. CO., 102 NASSAU STREET, ROCKFORD, ILL., U. S. A.

EAGLE
"MIKADO"



PENCIL
No. 174



Regular Length, 7 inches

For Sale at your Dealer. Made in five grades. Conceded to be the Finest Pencil made for general use.

EAGLE PENCIL COMPANY, NEW YORK

Get It in the Negative

But—to Get the Right Negative—One Should Use the Right Plate—

THAT'S THE

CENTRAL DRY PLATE

Ask Your Dealer for Them. If He Cannot Supply You, Write Us.

Central Dry Plate Co.

The Home of Standardized Plates

**BENAVIS,
ST. LOUIS, MO.**

**NEW YORK DEPOT
57 EAST NINTH ST.**

Economical and Convenient

SEPTONA

The Efficient Toning Solution for All Developing Papers

This product is free from all the disagreeable features of the Ferri Cyanide and Hypo Alum baths, eliminating all foul odors, and scalding of the hands.

SEPTONA will render beautiful warm tones in two to ten minutes according to the temperature of the bath—can be used either hot, warm or cold. A trial bottle will convince you of its merits.

8-oz. bottle making 1,600 ozs. of Toning Bath, will tone 800 5 x 7 prints.

PRICE \$1 PER BOTTLE.
Directions with every bottle.

Ask Your Dealer

L. HALLEN

Drane Building

Lakeland Florida

Always Ready for Use

Wynne Infallible Hunter Exposure Meter

The Wynne Infallible Hunter Meter has been specially designed to attain the maximum of simplicity, convenience and efficiency, with a minimum diameter and thickness of case—the case being only one-quarter of an inch in thickness. It is beautifully made in the best Solid Nickel and opens automatically by pressure of the small knob on the pendant.



On the right-hand side of the open case is the Actinometer with standard tints and sensitive paper. On the left-hand side of the case are the two scales for the calculation of the exposures. The top dial is interchangeable, so that scales according to either F, U S or specially divided scales for Autochrome exposures can be instantly substituted for one another.

When ordering please specify which style of scale is desired (F or U S)

Hunter Meter.....\$3.50

GEORGE MURPHY, Inc.

57 E. 9th St. New York

Sole American Agents

BACKGROUNDS

An Artistic Background is the greatest aid to Studio Portraiture.

An Artistic Background is a satisfaction to the photographer and a pleasure to his client.

We issue catalogues and furnish photographs to show, also to create suggestions.

Our New Catalogue and twelve photographs of designs now ready.

New Designs shown in photographs every few months.

We are now supplying the **FLATTED OIL BACKGROUND**. Flatted Oil Grounds are indestructible, rolling without cracking, impervious to dampness or wet, and specially suited for Resort trade, where exposure cannot be avoided.

We make Flatted Oil Grounds from any design, or from those shown in our catalogue or photographs submitted.

If you desire a Background, write us and state style desired, and we will send catalogue and submit photographs for inspection.

ROUGH & CALDWELL CO.

57 East Ninth Street,

New York City



*Seneca Cameras
bring home the
Pictures*

Seneca Camera Mfg. Company
Rochester, N. Y.

HAMMER PLATES

Have won distinction by merit alone.

Purity of chemicals, extreme care in manufacture and rigid inspection give them preference over all.

Hammer's Special Extra Fast (red label) and Extra Fast (blue label) Plates for field and studio work, and Hammer's Extra Fast Orthochromatic and D. C. Orthochromatic Plates for color values.

*Hammer's Little Book,
"A SHORT TALK ON NEGATIVE MAKING,"
mailed free*



HAMMER DRY PLATE COMPANY
Ohio Avenue and Miami Street ST. LOUIS, MO.

"Photo Finish World"

THE
ORIGINAL
Photographic Blotting

Best by test. Chemically pure and non-linting.

If you have used it you know its merits.

If you have not—

Working Samples on Request

The Albemarle Paper Mfg. Co.

Makers

Richmond,

Virginia,

U. S. A.

Make Your Prints in Colors (40 Shades)

An Explanatory Diagram Showing the Various Stages in the Production of AUTOTYPE CARBON PHOTOGRAPHS

The Production of an Autotype Carbon Photograph HOW IT IS DONE

A
The Coated Surface of Exposed Carbon Tissue (Pigmented Gelatine).

B
Single Transfer Paper.

C
Soak A and B in cold water, bring coated surfaces together in contact and squeeze.

D
Place the adherent tissue and transfer paper between blotting boards for a few minutes. Next immerse in warm water, until the colored gelatine begins to ooze out at the edges.

E
Strip off the Tissue backing paper and throw it away.

F
A dark mass of colored gelatine is left on the transfer paper. This remains in the warm water and the gelatine surface is sprinkled over until the picture gradually makes its appearance.

G and H
Continue until completed.

I
The picture is now placed in an alum bath (five per cent) to harden the film and discharge the bichromate sensitizing salt. A rinse in cold water completes the operation.

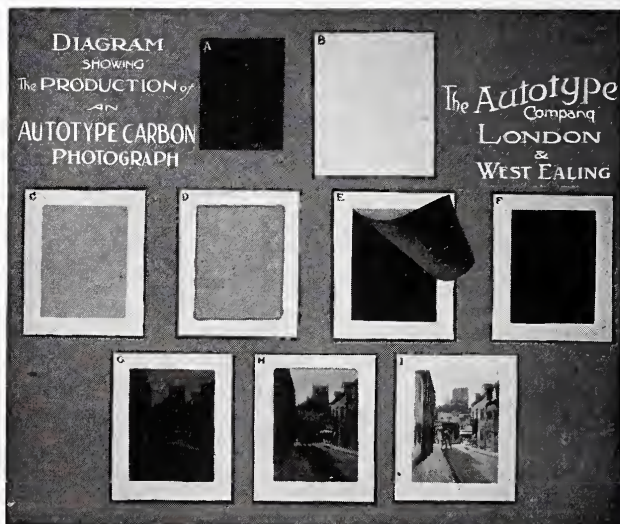

TRIAL SETS OF CARBON PRINTING MATERIALS

In order to combat the erroneous notion, somewhat prevalent amongst Amateur Photographers, that a trial of the Carbon Process necessarily entails the expenditure of a considerable sum on costly apparatus, we have decided to introduce trial sets of the absolutely essential materials.

PRICES OF TRIAL SETS

No. 1 Outfit for 5 x 7.....\$1.75 Postpaid
No. 2 Outfit Complete for 5 x 7..... 5.75
No. 4 Outfit Complete for 8 x 10..... 8.00 "

American Agents, GEORGE MURPHY, Inc., 57 East 9th St., New York
Send for Booklet



Colona

The paper that more than meets your expectations. The ideal rapid printing medium for the Amateur and Professional

alike. Will balance prints excelling in gradation and tones.

Quality of Emulsion is the keynote of Colona Success. Snappy brilliant prints that sparkle and attract; made in less time because of rapid exposure and development that the busy man appreciates.

Made in three grades with latitude so distributed that there is a grade suitable from the softest to the most contrasty negative.

**GRADES: SOFT; NORMAL—CONTRAST
SURFACES. SEMIMATT—MATT—GLOSSY**

Crystalla Portrait Paper

A soft toned portrait paper. For the Studio and Home Portraiture Photographer. Crystalla makes "Sepias" good to look at by the hot or cold process.

One Standard Quality of Emulsion. Two speeds: Fast and Slow.

Black Print Paper

For the commercial photographer. A grade particularly adapted to the production of Superior Enlargements, Bromide or Chloride.

Ultra reasonable in price.

Your dealer will supply you, or direct

Sussex Photo Supply Co.
NEWTON, N. J.

ENSIGN REFLEX CAMERAS

Size $3\frac{1}{4} \times 4\frac{1}{4}$ In. Plates or Film Packs

THE BEST REFLEX NEWS!

*Supplies of Ensigns
to Be Had Shortly*

For the enthusiastic camera user, the one who knows, no other model can replace the Ensign. Simplified as to operation so that any one can successfully use them who knows the A-B-C of photography.

Let your camera be an Ensign Reflex; your picture results will improve beyond belief.

Ensign Reflexes are constructed from the best selected materials, handsomely finished in every little detail, and then—Ensigns are equipped with the Ensign Self-capping Focal Plane Shutter, the Secret of Ensign Superiority; sets by the simple adjustment of one dial, curtain aperture and desired tension for exposures from 1-10th to 1-1000th part of a second; also time and bulb

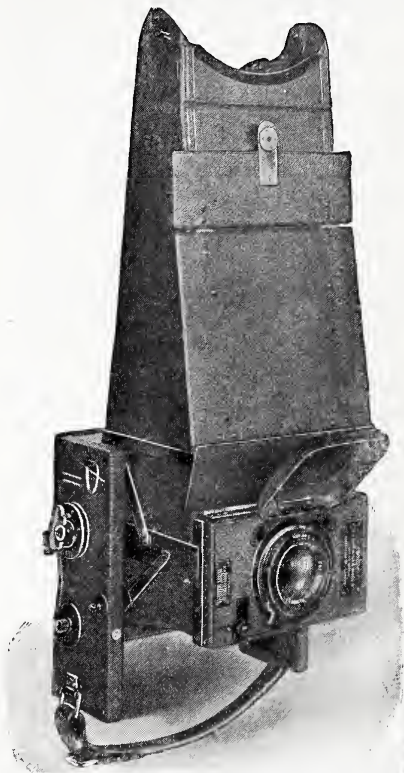

exposure. See the picture right side up until the instant of exposure, then a slight pressure on a lever releases the shutter evenly and correctly timed, free from vibration.

Prices:

ENSIGN FOLDING REFLEX, without lens, 3 Double Plate Holders, \$110

ENSIGN POPULAR REFLEX

Prices quoted later

We expect to be able to supply a choice of All Standard Lenses.

Your Dealer Will Supply You or Send Direct for Descriptive Literature

C. GENNERT

New York, 24 E. 13th St.
Chicago, 320 S. Wabash Ave.
Los Angeles, 127 E. 6th St.



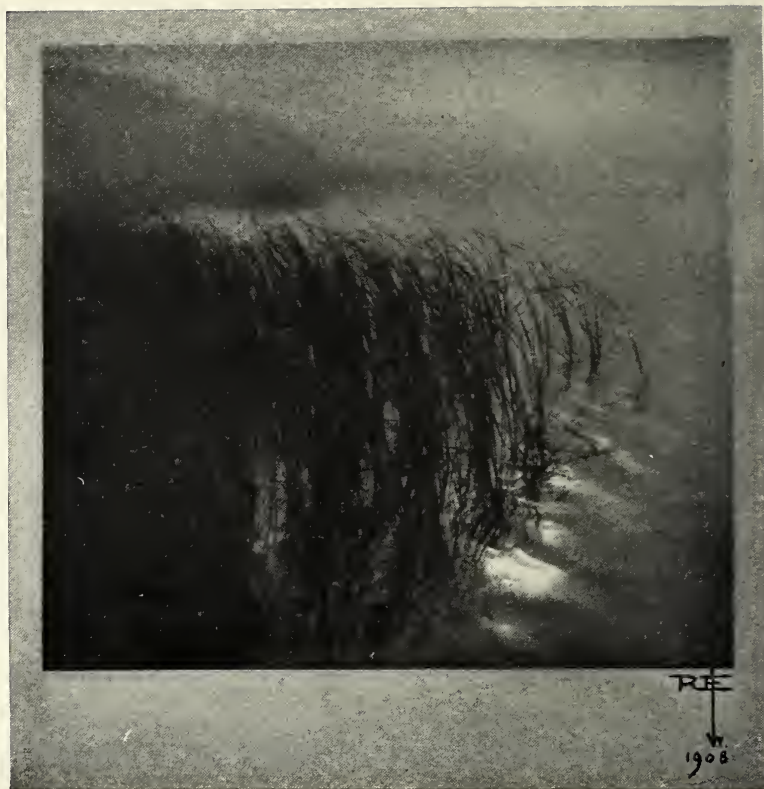

*And thou fair lake whose water quaff
The light of heaven like Lydia's sea.*
—Catullus.

Rudolf Eickemeyer, M.R.P.S.

The American Annual of Photography 1920

VOLUME XXXIV

Edited by Percy Y. Howe



NEW YORK

THE AMERICAN ANNUAL OF PHOTOGRAPHY, INC.

MCMXIX

[TRADE MARK REGISTERED]

Copyright, 1919, by
THE AMERICAN ANNUAL OF PHOTOGRAPHY, INC.,
New York.

FEDERAL PRINTING CO., NEW YORK

THE GETTY CENTER
LIBRARY

P R E F A C E



HIS, the thirty-fourth edition of the American Annual, was prepared during the reconstruction period following the great world war in which the camera played so important a part.

While, due to Government restrictions, photography was somewhat suppressed during the past few years, now that advantage can be taken of the many lessons learned, we look for marked progress.

We take this opportunity of expressing our sincere thanks to all who have in any way assisted in the preparation of this volume.

Contributions for the 1921 edition can be forwarded any time prior to July 1st, 1920, to 422 Park Hill Avenue, Yonkers, N. Y.

PERCY Y. HOWE, Editor.

TABLE OF CONTENTS

Contributed Articles

	PAGE
The Practical and Intellectual Value of Photography. By A. H. Beardsley.	9
Relief Images. By Dr. Braxton D. Avis.....	18
Snapping Children. By C. H. Claudy.....	22
The Pictorial Point of View. By William S. Davis.....	28
On Making Landscapes. By Stillman Taylor.....	32
The Dore Type. By S. A. Schwarz.....	<i>Illustrated</i> 34
In Search of the Picturesque. By J. E. Adhams.....	48
Economics in Portraiture. By T. W. Kilmer.....	<i>Illustrated</i> 52
Principal Faults of Prints Submitted for Publication. By J. E. Carson.....	56
The Camera and the Microscope. By J. A. E. Ernest Zimmerman, B.S.....	60
The Graflex for Pictorial Work. By Paul L. Anderson.....	64
Seeing and Feeling. By Guy Spencer.....	82
Stereoscopic Photography. By H. W. Hales.....	<i>Illustrated</i> 86
Where Cameras Are Not Allowed. By George Steele Seymour.....	<i>Illustrated</i> 90
Simplifying an Exposure Meter. By John Boyd.....	98
An Amateur's Work-Room. By Carl A. Peterson.....	<i>Illustrated</i> 102
Modern Portraiture. By August Krug.....	106
Nature Photography. By Arthur H. Farrow.....	<i>Illustrated</i> 112
Possibilities of Telephotography. By Frederic Felix.....	<i>Illustrated</i> 120
Photographing the Eclipse. By Carl Krebs.....	<i>Illustrated</i> 128
Pinhole Photography. By Mark W. Stevens.....	<i>Illustrated</i> 132
Photographic Selections for 1920. By Dr. R. W. Shufeldt.....	<i>Illustrated</i> 140
With the Camera in Florida. By F. W. Hill.....	<i>Illustrated</i> 150
Combined Daylight and Flashlight. By George W. French.....	<i>Illustrated</i> 154
Photography and Nature Study. By A. E. Davies.....	<i>Illustrated</i> 160
Home-Made Time Savers. By C. Erwin Ayers.....	<i>Illustrated</i> 164
The Exigencies of Composition. By Edward R. Dickson.....	<i>Illustrated</i> 168
A Plea for the Single Lantern. By G. T. Harris.....	174
Tanks, Developers and Exposure Meters. By Floyd D. Palmer.....	184
Composition. By Richard I. Grace.....	194
A Plea for the Small Plate Camera. By G. H. S. Harding.....	198
How to Construct Electric Flash Lamp. By Oscar C. Kuehn.....	<i>Illustrated</i> 202
Business and Pleasure. By Wm. H. Broadwell.....	<i>Illustrated</i> 208
A Box Camera with an F 3/5 Picture Camera Lens. By Walter W. Morey,	<i>Illustrated</i> 216
The Great Modern Advance in Portraiture. By Henry J. Weber.....	<i>Illustrated</i> 220
Many Ways of Using a Camera. By John Bieseman.....	224
A Simple Home-Made Printing Machine. By Henry F. Raess.....	<i>Illustrated</i> 232
Reflections in Photographs. By A. Lockett.....	<i>Illustrated</i> 237
Are You A. C. C. M.? By Rabamat.....	248
Seashore Photography. By Dr. A. M. Sutton.....	<i>Illustrated</i> 252
Direct Photography Without Using the Copying Lens. By Cheever C. Conlee	264
The Pursuit of an Ideal in the Great Out Doors. By Wm. E. Ziegenfuss, M. D.	<i>Illustrated</i> 266
American Annual Formulary.....	274
U. S. Weights and Measures.....	283
English Weights and Measures.....	284
Metric System of Weights and Measures.....	285
Conversion of Metric Into English Measure.....	286
Chemical Elements: Their Names and Symbols.....	287
Table of Solubilities.....	288
Table for Calculating Distances in Enlarging and Reducing.....	289
Table of Distances for Use in Focusing.....	290
Uniform System Numbers for Stops.....	291
American Photographic Societies.....	292

Index to Subjects

PAGE		PAGE	
Acid Fixing Bath.....	276	Lenses	72
Adhesive for Labels.....	280	Lenses, Cleaning	281
Amidol Formula	180, 274	Mask	164
Architectural Photography	208	Metol Formula	274, 275
Autochromes	280	Metric System	285
Azol Formula	276	Microscope and Photography.....	60
Blackening for Brass.....	281	Monomet Formula	275
Blackening Mixture	281	Moonlight Effects	281
Bleacher	44	Mounting	282
Blue Print Paper.....	277	Nature Photography.....	112, 160, 266
Bromide Paper	277	Non-Abrasion Soda Mixture.....	282
Cameras	216, 224	Para-Amidolophenol Formula.....	275
Camera Clubs	248, 292	Paste	282
Children, Photographing	22	Pictorial Photography	9, 28, 48, 64, 82, 150
Cleaning Bottles	281	Pinhole Photography	132
Carbon Process	278	Photographing the Eclipse.....	128
Clearing Stains	281	Plate Cameras	198
Composition	168, 194	Plate Speeds	287
Conversion of Metric System.....	286	Platinum Paper	279
Cutter for Cloth	166	Poison and Antidotes.....	282
Daguerreotypes	282	Polished Surfaces	282
Developers	44, 184	Portraiture.....	52, 84, 106, 220
Diamidophenol	274	Prints, Faults of.....	56
Direct Photography	264	Printing Machine	232
Doré-Type	34	Printing-out Papers	280
Dyeing	46	Pyro Formula	180, 275, 276
Elements, The	287	Re-developer	44
English Weights	284	Reduction	277
Enlarging	289	Reflections	237
Exposure Meters.....	98, 184	Relief Images	18
Farmers' Reducer	277	Rodinal Formula	276
Ferrous Oxalate Formula.....	274	Safe Lights	282
Film to Remove.....	281	Salted Paper	280
Firelight Effects	281	Shutter Release	228
Fixing Baths	276	Seashore Photography	252
Flashlight Photography	154, 202	Size of Plates	70
Flatten Prints	282	Societies, List of.....	292
Florida, Camera In.....	150	Solubilities of Chemicals.....	288
Flower Photography	140	Stains, Removing	282
Focusing Table of Distances.....	290	Stereoscopic Photography	86
Graflex for Pictorial Work.....	64	Studio, Length of.....	290
Ground-Glass Substitute	281	Tables of Distances.....	290
Gum-Bichromate	279	Tank Developers.....	184, 275
Hardeners	276	Telephotography	120
Hydrochinon Formula	274, 276	Test for Hypo.....	282
Hypo Test	282	U. S. Diaphragms.....	291
Intensification	182, 276	U. S. Weights	283
Kallitype	279	Value of Photography.....	9
Landscape Photography	32	Weights and Measures.....	283
Lantern Slides	174, 276	Work-room	102
Length of Studio.....	290		

Index to Authors

	PAGE		PAGE
Adnams, J. E.....	48	Hill, F. W.....	150
Anderson, Paul L.....	64	Kilmer, T. W.....	52
Avis, Dr. Braxton D.....	18	Krebs, Carl.....	128
Ayers, C. Erwin.....	164	Krug, August.....	106
Beardsley, A. H.....	9	Kuehn, Oscar C.....	202
Bieseeman, John.....	224	Lockett, A.....	237
Boyd, John.....	98	Morey, Walter W.....	216
Broadwell, Wm. H.....	208	Palmer, Floyd D.....	184
Carson, J. E.....	56	Peterson, Carl A.....	102
Claudy, C. H.....	22	Rabamat.....	248
Conlee, Cheever C.....	264	Raess, Henry F.....	232
Davies, A. E.....	160	Schwarz, S. A.....	34
Davis, W. S.....	28	Seymour, George Steele.....	90
Dickson, Edward R.....	168	Shufeldt, Dr. R. W.....	140
Farrow, Arthur H.....	112	Spencer, Guy.....	82
Felix, Frederic.....	120	Stevens, Mark W.....	132
French, Geo. W.....	154	Sutton, Dr. A. M.....	252
Grace, Richard I.....	194	Taylor, Stillman.....	32
Hales, H. W.....	86	Weber, Henry J.....	220
Harding, G. H. S.....	198	Ziegenfuss, Dr. Wm. E.....	266
Harris, G. T.....	174	Zimmerman, J. A. E. Ernest, B.S..	60

Index to Illustrators

	PAGE		PAGE
Adams, W. G.....	55	Goetz, Louis A.....(Insert)	104
Adnams, J. E.....	49, 51	Hales, H. W.....	86, 89
Allison, J. B.....	101	Harding, G. H. S.....	199
Anderson, Paul L.....	67, 69, 71	Hargett, A. B.....(Insert)	160
Armer, Laura Adams.....	189	Harris, G. T.....	175
Astellia, Louis.....(Insert)	168	Harthan, Addie M.....	162
Ayers, C. Erwin.....	165, 166	Harting, G. W.....(Inserts)	120, 224
Baker, Lawrence.....(Insert)	192	Hickman, Wilfred.....	236
Berkey, Irving.....	184	Hill, F. W.....	150, 151
Bill, J. Anthony.....	87	Hitchin, A. L.....	111, 183
Boughton, Alice.....	197	Hungerford, Blanche C.....(Insert)	152
Bourgeois, Cleo. S.....	229	Irons, Herbert.....	45
Boyd, John.....	100	Jeffery, H. C.....	191
Broadwell, Wm. H.,	208, 209, 210, 211, 213	Kilmer, T. W.....	52, 53
Bridge, Rupert.....	81	Knaff & Brakebill.....	19, 133
Brown, Fedora E. D.....	125	Krebs, Carl.....	128, 130, 131
Carlyle, Thos. C.....	75	Kriebel, William F.....	21
Carter, F. William.....	39	Krug, August.....	106, (Insert) 184
Cohen, Edgar A.....	139	Kuehn, Oscar C.....	204, 206
Congdon, Herbert Wheaton.....	63	Laity, Warren R.....	147
Conkling, O. C.....	179, 261	Lewisohn, John.....	172
Conlee, Cheever C.....	265	Libby, Francis Orville.....	43
Cooke, Helen W.....	23	Lockett, A.,	238, 239, 240, 241, 242, 243, 245
Crandall, Ernest L.....	263	Loker, Edwin.....	13, 267
Daring, Arthur.....	79	Lovegrove, Irving S.....	251
Davies, A. E.....	163	Ludlum, Wm.....	135
Davis, William S.....	29, 31	Marden, John.....	247
Dickson, Edward R (Insert)	40, 170, 171	Martin, Nelson C. D.....	201
Doutt, Chas. W.....	20, 82	Mathews, Kate.....	110
Dreyer, A. N.....	119	Miller, Bertha M.....	273
Eickemeyer, Rudolph, M.R.P.S.,	Insert facing Page 1; Insert	Moeller, Ernest.....	205
Eitel, Theodore.....(Insert)	248	Morey, Walter W.....	217, 218
Elliott, Arthur.....	227	Newhall, Earl A.....	187
Elliott Studio.....	271	Paton, James E.....(Insert)	256
Ellis, Wm. Shewell,	Insert facing Page 9	Peterson, Carl A.....	102, 103, 104
Farrow, Arthur H.....	112, 114, 115	Phister, Harry G.....	196
Felix, Frederic.....	122, 123, 126, 127	Pohle, Frederick.....(Insert)	88
Findlay, William.....	173	Poole, Edgar N.....	85
Fischer, O. E., M.D., (Inserts)	32, 64	Raess, Henry F.....	233, 234, 235
Fleckenstein, Louis.....	11, (Insert) 232	Reece, Jane.....	113
French, George W.....	155, 157, 159	Rice, C. P.....	215
Gabriel, Herman.....	181	Risdon, S. B.....	54
Gardner, Jared.....	27	Roberts, Edwin A.....	167
Gill & Son.....	117	Salazer, F.....	120
		Scaife, Rowland E.....	15
		Schieren, H. V.....	59

Index to Illustrators—Continued

	PAGE		PAGE
Schwarz, S. A.....	37, 40, 41	Taylor, R. B. M.....	255
Seymour, George Steele,		Thompson, Maurice.....	214
91, 93, 95, (Insert)	128	Thomson, James.....	231
Shufeldt, Dr. R. W.,		Tyler, Edna Leighton.....	149
140, 141, 143, 144, 145, 146		Volkman, O. J.....	193
Smith, Kenneth Dudley.....	177	Vos, Martin.....	47
Smith, May L.....	99	Wakeford, C. E.....	109
Snyder, Chas. L.....	61	Webb, Sidney V.....	35
Starr, Wm. T.....	17, (Insert) 24	Weber, Henry J.....	219, 221, 223
Steele, Louis J.....	83, (Insert) 96	Weston, Edward.....	(Insert) 56
Stevens, Mark W.....	134, 136	White, W. S.....	77
Surdam, Mabel Cox.....	(Insert) 288	Whitehead, John M.....	203
Sutton, Dr. A. M.,		Willard, Stephen H.....	16, 207
252, 253, 254, 256, 258, 259, 260, 262		Womersley, W. H.....	195
Sweet, L. D.....	(Insert) 136	Ziegenfuss, Dr. Wm. E.....	266, 269, 270

Index to Advertisers

	PAGE
AnSCO Company	Insert before i
Air Brush Mfg. Co.....	xxvi
Albemarle Paper Mfg. Co., The	xxix
American Photographic Publishing Co.....	xii, xiii
Bass Camera Co.....	viii
Central Dry Plate Co.....	xxvi
De Roos, Henry G.....	xxii
Eagle Pencil Co.....	xxvi
Eastman Kodak Co.....	Fourth cover, xvii-xxi
Engel Mfg. Co.....	xxvi
Gennert, G.....	xxxii
Gilbert Supply Co.....	xxiv
Goerz, C. P., American Optical Co.....	vii
Gray, R. D.....	xv
Guide to Nature, The	xxv
Haeusser, Chas.....	xiv
Hallen, L.....	xxvii
Hammer Dry Plate Co.....	xxix
Harvey, G. L.....	xxiv
Higgins & Co., Chas. M.....	xxv
Ilex Optical Co.....	ix
Japanese Water Color Co.....	xxiv
Johnston, J. W.....	xxii
Keasbey, Frederick W.....	xxv
Lewis, J. L.....	xxiv
Murphy, Inc., George.....	Second and Third covers; i, iv, xvi, xxvii, xxx
New York Camera Exchange.....	xi
New York Institute of Photography.....	xxv
Presto Mfg. Co.....	vi
Rough & Caldwell Co.....	xxvii
Sagamore Chemical Co., Inc.....	xiv
Seneca Camera Co.....	xxviii
Simplex Photo Specialty Co.....	v
Sinclair, H. J.....	xxiii
Sussex Photo Supply Co.....	xxxi
Tennant & Ward.....	ii
Ulrich & Co., P. D.....	x
Willoughby Inc., Charles G.....	v
Wollensak Optical Co.....	iii

REFERENCE CALENDAR FOR THREE YEARS

1919

	S	M	T	W	T	F	S		S	M	T	W	T	F	S		S	M	T	W	T	F	S
Jan.	1	2	3	4	May	1	2	3	Sept.	..	1	2	3	4	5	6	
	5	6	7	8	9	10	11		4	5	6	7	8	9	10		7	8	9	10	11	12	13
	12	13	14	15	16	17	18		11	12	13	14	15	16	17		14	15	16	17	18	19	20
	19	20	21	22	23	24	25		18	19	20	21	22	23	24		21	22	23	24	25	26	27
	26	27	28	29	30	31	..		25	26	27	28	29	30	31		28	29	30
Feb.	1	June	Oct.	1	2	3	4	
	2	3	4	5	6	7	8		1	2	3	4	5	6	7		5	6	7	8	9	10	11
	9	10	11	12	13	14	15		8	9	10	11	12	13	14		12	13	14	15	16	17	18
	16	17	18	19	20	21	22		15	16	17	18	19	20	21		19	20	21	22	23	24	25
	23	24	25	26	27	28	..		22	23	24	25	26	27	28		26	27	28	29	30	31	..
Mar.	1	..	July	Nov.	1	
	2	3	4	5	6	7	8		1	2	3	4	5		2	3	4	5	6	7	8
	9	10	11	12	13	14	15		6	7	8	9	10	11	12		9	10	11	12	13	14	15
	16	17	18	19	20	21	22		13	14	15	16	17	18	19		16	17	18	19	20	21	22
	23	24	25	26	27	28	29		20	21	22	23	24	25	26		23	24	25	26	27	28	29
	30	31		27	28	29	30	31		30
April	1	2	3	4	5	Aug.	1	2	Dec.	..	1	2	3	4	5	6
	6	7	8	9	10	11	12		3	4	5	6	7	8	9		7	8	9	10	11	12	13
	13	14	15	16	17	18	19		10	11	12	13	14	15	16		14	15	16	17	18	19	20
	20	21	22	23	24	25	26		17	18	19	20	21	22	23		21	22	23	24	25	26	27
	27	28	29	30		24	25	26	27	28	29	30		28	29	30	31
		31

1920

	S	M	T	W	T	F	S		S	M	T	W	T	F	S		S	M	T	W	T	F	S						
Jan.	1	2	3	May	1	Sept.	1	2	3	4							
	4	5	6	7	8	9	10		2	3	4	5	6	7	8		5	6	7	8	9	10	11						
	11	12	13	14	15	16	17		9	10	11	12	13	14	15		12	13	14	15	16	17	18						
	18	19	20	21	22	23	24		16	17	18	19	20	21	22		19	20	21	22	23	24	25						
	25	26	27	28	29	30	31		23	24	25	26	27	28	29		26	27	28	29	30						
Feb.	..	1	2	3	4	5	6	June	1	2	3	4	5	Oct.	1	2	..						
	8	9	10	11	12	13	14		6	7	8	9	10	11	12		3	4	5	6	7	8	9						
	15	16	17	18	19	20	21		13	14	15	16	17	18	19		10	11	12	13	14	15	16						
	22	23	24	25	26	27	28		20	21	22	23	24	25	26		17	18	19	20	21	22	23						
	29		27	28	29	30		24	25	26	27	28	29	30						
Mar.	July	1	2	3	Nov.							
	1	2	3	4	5	6	7		4	5	6	7	8	9	10		..	1	2	3	4	5	6						
	7	8	9	10	11	12	13		11	12	13	14	15	16	17		7	8	9	10	11	12	13						
	14	15	16	17	18	19	20		18	19	20	21	22	23	24		14	15	16	17	18	19	20						
	21	22	23	24	25	26	27		25	26	27	28	29	30	31		21	22	23	24	25	26	27						
	28	29	30	31		28	29	30						
April	1	2	3	..	Aug.	1	2	3	4	Dec.	1	2	3	4
	4	5	6	7	8	9	10		1	2	3	4	5	6	7		5	6	7	8	9	10	11						
	11	12	13	14	15	16	17		8	9	10	11	12	13	14		12	13	14	15	16	17	18						
	18	19	20	21	22	23	24		15	16	17	18	19	20	21		19	20	21	22	23	24	25						
	25	26	27	28	29	30	..		22	23	24	25	26	27	28		26	27	28	29	30	31	..						
		29	30	31						

1921

	S	M	T	W	T	F	S		S	M	T	W	T	F	S		S	M	T	W	T	F	S
Jan.	1	..	May	1	2	3	4	5	6	7	Sept.	1	2	3
	2	3	4	5	6	7	8		8	9	10	11	12	13	14		4	5	6	7	8	9	10
	9	10	11	12	13	14	15		15	16	17	18	19	20	21		11	12	13	14	15	16	17
	16	17	18	19	20	21	22		22	23	24	25	26	27	28		18	19	20	21	22	23	24
	23	24	25	26	27	28	29		29	30	31		25	26	27	28	29	30	..
	30	31
Feb.	1	2	3	4	5	June	1	2	3	4	Oct.
	6	7	8	9	10	11	12		5	6	7	8	9	10	11		2	3	4	5	6	7	8
	13	14	15	16	17	18	19		12	13	14	15	16	17	18		9	10	11	12	13	14	15
	20	21	22	23	24	25	26		19	20	21	22	23	24	25		16	17	18	19	20	21	22
	27	28		26	27	28	29	30		23	24	25	26	27	28	29
Mar.	1	2	3	4	5	July	1	2	Nov.
	6	7	8	9	10	11	12		3	4	5	6	7	8	9		6	7	8	9	10	11	12
	13	14	15	16	17	18	19		10	11	12	13	14	15	16		13	14	15	16	17	18	19
	20	21	22	23	24	25	26		17	18	19	20	21	22	23		20	21	22	23	24	25	26
	27	28	29	30	31		24	25	26	27	28	29	30		27	28	29	30
		31		30	31
April	1	2	..	Aug.	..	1	2	3	4	5	6	Dec.	1	2	3
	3	4	5	6	7	8	9		7	8	9	10	11	12	13		4	5	6	7	8	9	10
	10	11	12	13	14	15	16		14	15	16	17	18	19	20		11	12	13	14	15	16	17
	17	18	19	20	21	22	23		21	22	23	24	25	26	27		18	19	20	21	22	23	24
	24	25	26	27	28	29	30		28	29	30	31		25	26	27	28	29	30	31

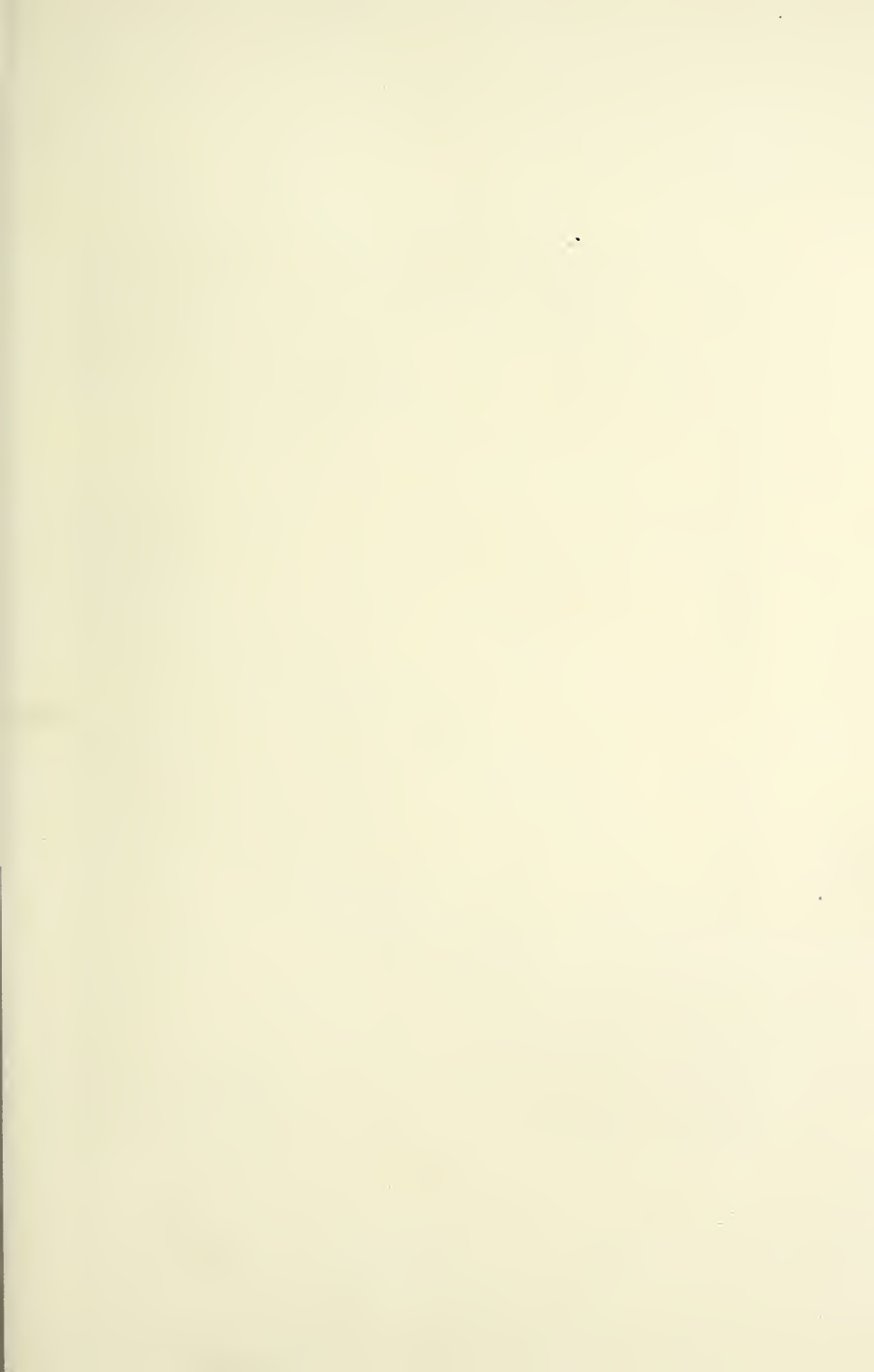



William Shewell Ellis.

The American Annual of Photography . . 1920

THE PRACTICAL AND INTELLECTUAL VALUE OF PHOTOGRAPHY

By A. H. BEARDSLEY



TO-DAY photography is too much of an art and a science to be treated lightly. To make good pictures requires more interest and perseverance than is usually called for by a passing whim. Sometimes, it seems needless to point out the importance of consistent effort in photography. To me, it appears self-evident that to obtain commendable results the camerist must show evidence of ambition and genuine interest. Virtually all successful human activities have their inception in careful thought and planning. The amateur who is really desirous to make a success of his camera-work should take himself aside and ask, "Do you consider your camera a plaything, or do you see in it wonderful possibilities for your physical and intellectual well-being"?

It is not my intention to make the beginner or the amateur photographer feel his photographic responsibilities so heavily that he loses all spontaneity of thought and action; but I do feel very strongly that photography is too much of an art and a science to be treated merely as a toy to while away an idle hour. I know from experience that the man who puts his very best thought and effort into all his photographic work is the one who will enjoy his camera-work the most and who will make the best pictures as well. In other words, photography merits the best thought and effort that a man or a woman can put into it; and, for this very reason, each step should be preceded by careful and practical preparation. Let the cam-

erist set a photographic goal worth striving for and then bend every energy to reach it—the rewards are commensurate with the sincerity of the effort.

Modern photography is simple. In fact, it is too simple for the good of the average amateur. By that I mean, that its very simplicity has a tendency to lull the mind of the camerist into the belief that he needs to do but little mentally or physically to achieve photographic success. By simplifying photography, manufacturers have made it possible for the man on the street to own a camera and use it successfully; but, at the same time, they have reduced the necessity of accuracy, skill and thought to a minimum, as far as the average amateur is concerned. How many amateurs could prepare even an acid-hypo bath from chemicals in bulk? Most of them purchase the acid-hypo ready prepared in a carton and merely add the necessary quantity of water—that is all. I admit readily that this “ready-to-serve” form of fixing-bath is a decided convenience; but my point is that the camerist loses much valuable chemical and technical knowledge by not mastering the method to compound a fixing-bath himself. I would not belittle or discourage the use of these ready-prepared chemicals—not for a moment; but I do think that every camerist should value photography sufficiently to learn the rudiments of photographic chemistry. Even if he never uses this knowledge in his work, the camerist will be the better for the experience. In short, the practical and intellectual value of photography lies in mastering its fundamentals thoroughly; then, the camerist may discard older and slower methods as he will; but his work will rest on a solid foundation of practical knowledge that will facilitate his rapid and successful progress.

Some of my readers may contend that my suggestions involve too much time and effort. I grant that time and effort are required; but isn't photography worth it? I am reasonably sure that the average man who buys an automobile does not begrudge the time it requires to master the manipulation of the engine, to change the tires and how to make minor repairs. There are comparatively few who would venture far in an automobile unless they could do these things if occasion demanded. Yet, there are amateur photographers who will go on long trips without the slightest knowledge of exposure,



MISS LUCY S.

LOUIS FLECKENSTEIN.

developing or printing. Such amateur photographers press the lever and let the corner drugstore do the rest. If, perchance, the film sticks in the camera, the ground glass is broken or the rear lens-cell becomes dusty, they are helpless to remedy the difficulty. Here again, the very simplicity of modern photography is to blame for a state of mind that assumes that no great effort is required to obtain results.

In the foregoing paragraphs I have tried to point out the need and the benefit of mastering the practical fundamentals of photography. There is no question but that the knowledge thus obtained is a direct asset financially and artistically. In short, the camerist is in a position to act with assurance; and, because of this very assurance, he produces results that are a credit to himself and to photography.

There should be little need for me to call attention to the direct physical benefits of photography. It must be obvious that to make landscapes, marines and outdoor-genres the camerist must get out into the open and often walk or ride many miles. Business and professional men and women are confined to stores and offices that are none too well ventilated or lighted. For this reason alone, photography is a veritable panacea to those who may not be able to indulge in strenuous exercise but who can walk without undue fatigue. However, those who may wish strenuous exercise, and adventure as well, will find that speed-photography and hunting wild game with a camera will demand extreme physical effort, coolness and rare skill. In consequence, those who have the physical benefit uppermost in mind will find that photography will not fail them any more than it fails those who love art and the beauties of nature.

Let us assume that the importance and value of the practical mastery of photographic fundamentals is admitted and likewise the physical benefits to be derived from photography; but what of its intellectual value? I am using the word "intellectual" in the sense of the mental benefit that may be obtained by camera-work. Any man who has the least love of nature or art dormant within him will find that the intelligent use of a camera will open up a new world. He will find that the things of beauty will make a strong appeal and that a desire to perpetuate beauty will become increasingly insistent until



STUBBORN WINTER DIES.

EDWIN LOKER.

he actually endeavors to make a photograph of every subject that he has learned to understand and to love. Naturally, most amateur photographers will follow their own bent with regard to picture-material. Some will devote their time and effort to marines; others to human-interest subjects; and still others to the beauties of nature. However, all in common will have experienced a mental transformation—a love of the deeper, truer things of life has become a permanent part of their characters. Such a mental evolution may occur as readily within the mind of a laborer as within the mind of a man of education. In one sense, photography “makes the whole world kin”. It unites men and women of high and low degree in the common effort to preserve pictorially for all time the beauties of nature and the best physical manifestations of human thought.

Perhaps, my readers may be inclined to pass over these paragraphs lightly under the assumption that I am striving for an effect. On the contrary, I am hoping to drive home the point that photography is daily becoming a vital factor in our business, social and private affairs. A song is sung; a speech is made; and the face of a loved one fades from the mind; but a picture—that lives forever! A few moments of careful thought will convince the reader that in photography he will find a tremendously powerful factor toward his physical and mental well-being. Golf, tennis, baseball and other sports are excellent; but would any athlete claim that such sports benefitted him intellectually? Remember that I use the word “intellectually” in its sense of the mental development of all that is highest and best in a man. Moreover, photography is not and never should be considered a sport or a pastime. It is a science and an art; and to master it requires greater mental effort than to play a good game of tennis.

Through photography the man on the street can be made to realize that the world is not a sordid, unhappy place in which to live. Even a city-park may be transformed into a fairyland that will soothe tired hearts and bring a refreshing sense of comfort to the discouraged toiler. Camera in hand and mind alert, a man or a woman may learn to forget the troubles of the day in the fascinating search for the beautiful. This is not visionary or idealistic; it is based on my personal experi-



ROWLAND E. SCAIFE.

ence with amateur photographers. I have seen mechanics, truck-drivers and day-laborers—physically exhausted from their labor—take their cameras and spend Sundays and holidays striving to express pictorially their conception of beauty. No one can tell me that these men did not return home physically rested and mentally improved. Moreover, I have seen such men spend the few moments of relaxation at the end of a long, hard day's work actually reading some book on pictorial composition that they might make better pictures on the following Sunday. If there is any cleaner, finer avocation for such men to pursue, I would like to know of it.

Obviously, the man who has had the advantages of education may appreciate the intellectual benefits of photography more quickly; but the man behind the lathe in the machine-shop and the man of education meet on common ground when it comes to the love of all that is beautiful in nature. In both cases, photography has awakened and then enabled each man to get more out of life because he has been made to seek in nature and among his own surroundings the things that ring true. There are several factors that bring out the good in a man and make him seek the higher, more beautiful things in life—photography is one of these.



LOOKING THROUGH THE GATES—
HARBOR OF BREST.

STEPHEN H. WILLARD.

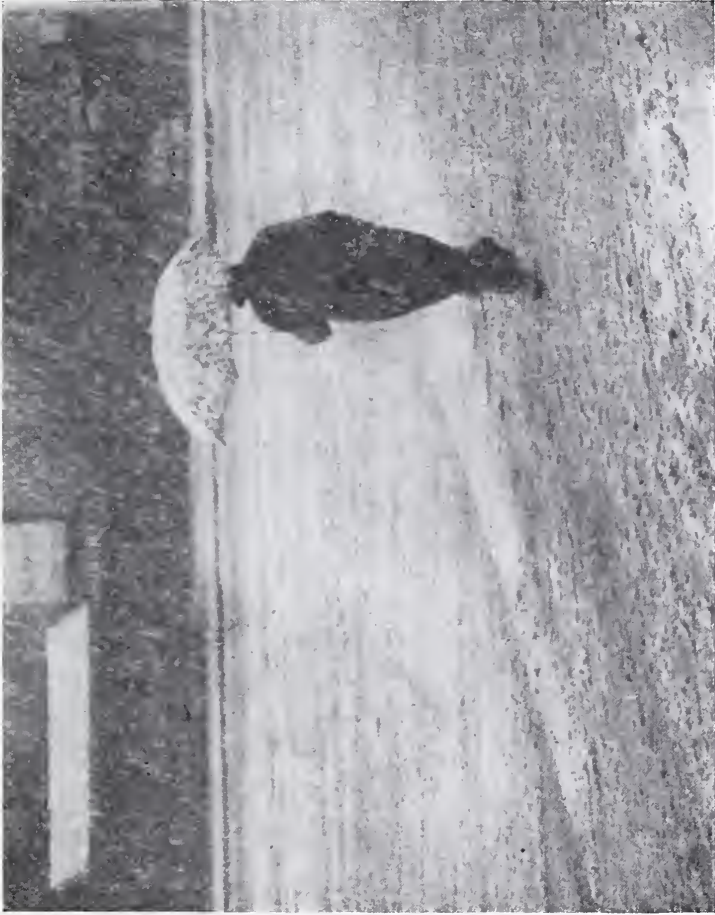

THE SNOW STORM.

WILLIAM T. STARR.

RELIEF IMAGES

By DR. BRAXTON D. AVIS



RECENTLY I observed a peculiar behavior of a film of bichromated gelatine after it had been exposed to the action of light for a short time, and then immersed into an aqueous solution of picric acid or sodium picrate, and dried.

Those parts of the gelatine film which have been exposed to light are found to be raised and if the exposure has been made under a negative, the image will stand out in relief. This behavior of a gelatine film when treated as above described may possibly be utilized in some branch of photography.

I will briefly describe the manner in which one of these relief images may be obtained. An ordinary dry plate composed of a good thick coating of gelatine emulsion is sensitized in a solution containing about thirty grains of potassium bichromate to a pint of water and dried in a dark place.

After drying the plate is exposed to light beneath a negative for two or three minutes, then removed from the printing frame and then washed in cold water to remove all soluble chromium salts. The plate is then put in a saturated aqueous solution of picric acid. This solution should be at a temperature of about 75° F., and the plate should remain in same for at least five minutes.

On examining the plate after its removal from the solution, aside from its yellow colour it will present the same appearance as if it had been treated with plain water—those parts of the film which have been protected from the light being higher than the other portions. On drying, the condition of the film is exactly the reverse; those parts that were protected from the light are in reality depressed. This depression of the film is proportional to the strength of the light acting on said film.



KNAFFL & BRAKEBILL.

My explanation of this phenomenon is that the picric acid forms a compound with the gelatine which when dry is much more dense and compact than normal gelatine. That this is the correct explanation, I believe, and is borne out by the fact that if the gelatine film has been exposed beneath a positive, and afterward treated with the picric acid solution, on drying the image will be represented by a depression in the gelatine. The exposed portions of the film have become more or less insoluble and the solution of picric acid is therefore unable to penetrate the film as freely as the unexposed parts and form the compound mentioned above.

It appears possible to utilize a relief image of this nature for obtaining prints photo-mechanically.

The plate in this case should be exposed under a grained negative instead of an ordinary one and then the image would be composed of numerous small raised dots of very hard gelatine, which should make a good printing surface, retaining ink readily.



C. W. DOUTT.



A WET DAY.

WM. F. KRIEBEL.

SNAPPING CHILDREN

By C. H. CLAUDY



PLEASE note that this little contribution to the *American Annual of Photography* is not entitled "The Art of Child Portraiture" nor "How to Picture the Child" nor even "Instantaneous Exposures on Small Models." It isn't anything as pretentious as such stories might well be. It's written about the kodak so simple that a child can operate it, and the chap or his sister who doesn't know all there is to know about focal plane shutters, anastigmatic lenses, orthochromatic values, ray-filters, composition and total balance. It isn't written that way because, in the first place, I don't know all about them, and in the second, it wouldn't do the average kodaker or his sister any great good if I did, and told what I knew.

The general public uses a camera to take pictures. The exception, not the rule, is he who delves deeply into photography for love of its science and becomes a master of the art. Many are too busy, others lack that peculiar turn of mind which makes anything which smacks of science seem also of the land of romance. If the kodak has gone 'round the world it is because it is a producer of results in hands whose owners not only do not know, but do not need to know, the science of chemistry or of optics which are the foundations on which all instruments and processes photographic are made.

But there is one thing which the manufacturers, be they never so alert to every opportunity, never so clever in devising those things which are "fool proof" in ignorant hands, never so able in simplifying the chemistry of photography with the sealed package of tested chemicals and the simplified process and easy-to-work directions . . . one thing they cannot do. They cannot make the *subjects* of pictures cooperate with the users of the kodaks.



IN THE SUNSHINE.

HELEN W. COOKE.

Hence it is that while anyone anywhere with any kodak, can, if he follow directions, produce some sort of a photograph of children, he will not usually, save by a lucky accident, produce the best possible photograph. Instrument will function perfectly . . . film will do its part . . . developing machine, or tank, simple gaslight paper and easy mounting process will complete the job without the need of understanding anything more abstruse than plain and simple directions. But unless the picture has been properly attended to before the lever or bulb was pressed, the result will usually leave something to be desired.

“Properly attended to” means but few and simple things, but they are very important things. First comes the matter of motion. What sort of kodak have you? Is it a little square box with a tiny lever which winks, winks, the shutter back and forth across the lens? Does it take rather small pictures, and is it of inexpensive variety? Then it has a lens which “works” at a rather low speed, and necessarily, a not very rapid shutter. It has the best lens and the fastest shutter which can go with it, which can be made for the money the whole costs . . . much of the increase in price as one goes up the scale of perfection in kodaks comes from better lenses and better (because faster) shutters to go with them.

Well, anyway, possession of such an instrument means that you cannot “stop” rapid motion at right angles and close to the lens. If you must make a picture of little Johnny and sister Sue running a race, take the picture with them running towards you. And if you are “snooping around” them as they play, hunting for those “unconscious studies” which so many writers on photographic topics (present scribe among the number) so highly recommend, press your little lever over at some point in childish play when motion is not violent or quick. So you shall have clear, sharp, unblurred pictures . . . as clear and as sharp and as unblurred as he who operates an anastigmat, a focal plane shutter and an ultra-rapid plate. The difference is that you must choose your time and the direction of motion with reference to your kodak . . . he can let fly almost any time, anywhere and “stop” the rapid movement.

There is nothing, however, in the possession of the most expensive outfit which money can buy, which gives its pos-



William T. Starr.

sensor any advantage over you and your modest priced little Bullseye, when it comes to getting pictures of children which are effectively lighted. The film the greatest expert uses in his most expensive of made-to-order instruments, behind his hundred-and-some-dollar lens, is the same film you buy for your instrument. It possesses in a large degree what is known as "orthochromatic quality", that is, its ability to render various colors in degrees of lights and shades which very nearly correspond to the visual brightness or dullness of those colors. So the user of the most inexpensive Brownie is, as far as his sensitive material is concerned, on a par with the best-equipped photographer.

That being so, it follows that where the one gets a magnificent "color" result, and the other a flat, unattractive picture, the difference is caused by something extraneous to the instrument. That "something" is almost invariably lighting. The elementary instruction in kodakery tells you that the light should fall full on the subject, and that you should stand with your back to it. So does elementary instruction on the piano keep your feet off the pedals and make scales the end and aim of the practice hour. But the pianist uses pedals and plays other things than scales, and the practiced user of the kodak need not . . . indeed, must not . . . adhere to beginner's conditions in choosing the lighting of his picture.

The kodaker of children outdoors has a multitude of lights and lighting effects to choose from. He may photograph with a side-light by doing his snapping in early morning or very late afternoon. He may have the light fall from any angle around the circle, even from directly behind the subject, if he sees to it that his lens is in the shade, so that no direct rays of sunlight enter it. He may utilize the principles of contrast, and picture his young sitters partly *en silhouette* by having a brightly lit background and so placing them that only shadow side faces the instrument, then using a smaller-than-usual diaphragm or "stop". He may involve some delightful effects with a rose bush and a "spotted" light, and vary his face lighting with hats of differing degrees of broadness of brim. I am much afraid no story can do more than hint at the possibilities . . . but if those hints turn anyone from the unhappy practice of standing a patient child up in the pitiless

top light of high noon and snapping him with the kodak pointing toward the north, they will be well worth their writing and printing here.

Just one more word . . . don't "pose" children any more than can be helped. The most attractive kodak snapshots of babies and small children at play are those in which the subjects are entirely unconscious of the fact that they are to be pictured. Children are rarely ungraceful, and the beholder forgives much of failure of complete perfection of composition in joy in seeing beauty and naturalness and interest . . . and any child picture may possess these. But make your little subjects self-conscious by insisting that they "stand right here, dear, and look at the tree" or "Smile, precious lamb, so Daddy can get your teeth in the picture" will usually result in one of those horrors which the unknowing attribute to the type and kind of instrument and not to the operator.

"What a fine lens you must have." How many times have we heard it when we showed some unusually happy result, as if it were all in the lens. It isn't. As far as children and kodaks are concerned, it's all in the operator.

And now to retire as gracefully and as learnedly as possible, let me add that a dozen experiments, to find out about lightings, and as much practice as may be possible, will do more to produce successful kodak pictures of small children than all the stories in the world!



THE SOLITARY PINE.

JARED GARDNER.

THE PICTORIAL POINT OF VIEW

By WILLIAM S. DAVIS



O the average individual untrained in art matters any recognizable representation upon paper of persons or objects is a "picture", which of course is true in a sense, but from the artists' viewpoint a picture must go beyond a matter-of-fact record made in a hit-or-miss manner and be a harmonious entirety, which involves thought as to the manner of expressing the idea one wishes to convey. For this reason a snapshot of a pet dog standing in front of a picket fence, a tree in the background apparently balanced upon the poor dog's head, and houses, telephone poles, and a few other sundries, filling the remaining space, would hardly be considered a success from the pictorial point of view, even though a passable likeness of the dog was obtained.

One might look upon the average photograph as an illustration, inasmuch as the primary purpose of what artists term "illustrations" is to show the likeness of some object, or describe something visually, instead of by words. This is not to say but what art is often present in a high degree in illustrations, but not always, since, for example, a photograph or drawing of some piece of machinery may be a mechanically perfect *illustration* of the object without there being an opportunity of artistic taste entering into it at all. Likewise, a technically clean cut photograph of a bit of scenery, or a building, might be an excellent view record of the locality without possessing any pictorial interest, as the latter term is now commonly understood.

Many who can pick out a pleasing photograph from a mass of indifferent ones make the mistake of thinking the difference in quality lies in selecting naturally pleasing subjects—a pretty face or a beautiful landscape, for instance—rather than the skill with which the chosen material is made to convey the idea



THE CITY OF TOWERS.

WILLIAM S. DAVIS.

of the worker. While I would not go so far as some seem to do to discredit the employment of obviously beautiful material, nevertheless, the fact cannot be too strongly placed before the beginner that the quality of the picture depends upon *the way the subject matter is treated* rather than dependence upon the attraction of some ready-made composition.

While many explanations have been given as to what is "Art", perhaps the majority of reliable opinion could be summed up by saying it is one's personal impressions, or ideas, beautifully expressed. This might, of course, be said of all varieties of artistic endeavor, but applied to "pictorial" photography it means that one must first have a definite impression as a "motif" for the picture—in other words some feeling or idea to convey to others. To make this visible in a striking, yet harmonious manner, demands not only care in the selection of just enough of the right material to serve one's purpose, but a grouping of the various units in such relation to one another as to obtain an attractive arrangement of lines and masses within the picture-space, combined with a truthful and harmonious rendition of the tonal gradations.

Lines and tones are the photographer's tools of expression, and being susceptible to innumerable combinations one can only gain satisfactory control over them at the cost of much thought, and study of nature, supplemented by reading and critical observation of good pictures, which exercise a broadening influence through showing how others have mastered various problems.



UNDER THE PORTICO,
NEW YORK PUBLIC LIBRARY.

WILLIAM S. DAVIS.

ON MAKING LANDSCAPES

By STILLMAN TAYLOR



HANCE will not often produce a good landscape which is the logical result of study and especially a consideration of the point of view of the scene. To snap-shot here and there may now and then give the amateur a photograph or two worth keeping, but the average run of pictures so made are scarcely worth the effort. Therefore, the first essential step in picture making is to determine the reason for photographing any particular object—is the desire to make a copy of something which has interested the eye, or do we want to show the beauty of a stretch of woodland or water by taking it from the best angle so that the result will appeal to the eye through the arrangement of line and tone? The record photograph is quickly taken, but the interesting landscape must be studied beforehand.

Choosing the subject is the first step, but in selecting the motif for the picture does not necessarily mean that any or every object which attracts and is pretty will make a good photograph. Hence, before selecting the subject, analyze it well. Perhaps it attracts by its color, in which case even the use of isochromatic plates and a ray filter will only disappoint, because the charm of such a scene lies in its coloring, and the monochrome art of the camera will but inadequately show it. Scenes of this kind are very common, but are only suitable for the painter, who alone can do them justice. This matter of color is responsible for much disappointment to the amateur, and even some skillful workers are now and then confused by it.

In selecting the subject it is well to remember that hundreds of interesting and attractive subjects are to be found everywhere, and the amateur need not journey far from home to find them. The unusual and grand scenic effects are more difficult to photograph, and are by no means of greater interest than the simple, natural scenes near home. If the subject is in



MORNING MISTS—BELLE ISLE.

O. E. Fischer, M.D.

any way striking or suggestive, it will make a good photograph, otherwise it is not worth taking.

Simplicity is the keynote of all artistic work and the amateur will be able to secure unity by avoiding the common mistake of crowding too much in his picture space, and by choosing that point of view in which the fewest possible lines are found to emphasize the scene. In other words, a landscape should have but one main object of greatest interest. Other objects may be included to afford the necessary variety, but these must be kept secondary to the main object or interest. A good composition is the result of selecting a subject in which all lines lead the eye to a central object.

A single tree with a long slanting shadow will often make a good picture, while the photograph of an entire woodlot would only confuse the eye with much meaningless details. It is therefore well to keep in mind that it is quite unnecessary when photographing a clump of trees to include the topmost branches down to the roots. Do not attempt to do too much, but rather try to make the most of a few well selected materials. After choosing an attractive subject, walk around it and look it over critically from various angles, and then by making the exposure from the best of these, you are likely to be rewarded with a print that best shows the interest which the scene has created in your mind when you first viewed it.

The amateur is often advised to photograph with the sun at his back, but the finest effects in light and shadow are usually gained when the camera is pointed more or less directly at the sun. In doing this, the lens is, of course, shielded from the direct glare, either by using a lens shade or by holding the hand or cap to one side and throwing a shadow on the lens. Usually it is possible to interpose a tree so that the shadow falls across the lens, for to let the sun shine directly in the camera will cause flare and spoil the picture. A good common sense rule is to try to secure rather broad masses of light and shadow and to avoid the spotty, broken-up effect. The time of day, season and weather all contribute to the effect, and if the amateur will study any scene under these varying conditions he will acquire more practical information on the subject in a few visits to some favorite scene, than he is likely to find in many books.

THE DORÉ-TYPE

By S. A. SCHWARZ



FOR a reason quite unknown the Doré-type has never reached the high degree of popularity which it so well deserves in the world of artistic photography. In speaking of this limited degree of popularity, I am particularly referring to the professional or semi-professional who has chosen the art of the latent image as his walk of life, and who above all has originality enough to digress from the ordinary beaten path of the stereotyped photo, and at times travels into the realm of highly artistic productions. The amateur who knows little or nothing of this type of photography must of course be pardoned. To him a process spreads an atmosphere of let-it-alone about itself, especially so if it is one which is not frequently encountered, and which, from all appearances involves some very difficult manipulations. My recent experiments in this particular field of photography have fully convinced me that any one who is familiar with either copying, enlarging, or transparency making, should with very little practice soon be able to produce some very beautiful results.

Before proceeding it might not be amiss to explain in detail what the real meaning of a Doré-type is, in what way does it differ from the ordinary photograph that it should be considered so much more beautiful and so much more artistic. What are its limitations if any, and lastly how is the Doré-type produced? -

Answering these questions in the order given, we may define the Doré-type as a transparent photograph on glass. After re-development it is backed by a piece of glass with a suitable illuminating medium such as tinted silk or colored cardboard between them. Then passe-partout these three units together to insure firmness and the Doré-type is complete. In this manner we obtain a reproduction which in richness of tone gradation and softness of modeling has no rival.



THE ORANGE.

SIDNEY V. WEBB.

Portraits as well as landscapes are equally well suited to this process and produce equally effective results. I have seen some landscapes enlarged from small negatives of vest pocket size and finished by the Doré-type process, so beautiful, so marvelously true to nature, and so full of atmosphere that they might well be considered masterpieces of the art of photography. Portraits, especially large heads in Rembrandt, or broad lighting, are particularly well suited to this method of reproduction. One of the chief characteristics, and in a measure the main recommendation of the Doré-type is its ability to impart a certain true-to-life roundness and plasticity to the features of the subject, thus emphasizing those salient characteristics of the individual so important in a good portrait.

There are three ways in which the Doré-type may be produced. Of course I do by no means wish to create the impression that these three methods are the only ones; quite the contrary, there may be many more and many of them very excellent; but of all methods which I have tried I have found these three the most satisfactory. There are certain limitations which accompany the first as well as the second methods which in a measure, and under certain conditions, may prove very discouraging. It is by the employment of the third method that I finally succeeded to eliminate the disagreeable draw-backs which presented themselves in the first two instances.

Before describing the various methods referred to in the previous paragraph a few words pertaining to the quality of the negative might be in order. Generally speaking all negatives suitable for enlarging will well adapt themselves to the making of the Doré-type. At times it may be necessary to resort to one of the many systems of dodging for the purpose of either accentuating or softening certain portions of the negative. A very efficient, and at the same time simple method of dodging is to cover the back of the negative with ground-glass varnish and thus obtain an excellent surface on which any additional work may be done to the heart's content of the operator.

The first and probably the simplest method is the one known as the direct contact printing method. The negative is placed into the printing frame in the usual manner and then backed by another plate so that the emulsion sides face each other. It is quite essential that both units should be free from dust. To



SUNSET.

S. A. SCHWARZ.

insure better contact it is sometimes necessary to interpose one or two thicknesses of (preferably dark) blotting paper between the back of the printing frame and the unexposed plate. This precaution lessens also the possibility of halation, or veiling which might occur, especially if the back of the printing frame is covered with some light colored material.

The exposure is probably the most difficult step in the entire operation. The conditions which govern this phase of work are so manifold that it is best for the worker to determine by careful experiment the exact time required to produce the best results. As a general guide it may be taken that the light from two burning wood matches at about 16 inches from the negative will give sufficient illumination to produce a good plate. Should a 16 c. p. incandescent bulb be employed at a distance of 24 inches, an exposure equivalent to "on and off" of the electric current will be found quite ample. It is of course understood that all work is to be carried on in absolute darkness with no other illumination except that coming from a safe light. Probably the most serious drawback to this method is the fact that all pictures reproduced will be of the same size as the original negative, which if the latter is of a small size is an item of no mean importance. Furthermore dodging will be found exceedingly difficult; in fact almost entirely out of question. If the photographer should not consider the above mentioned a setback of a serious nature the method owing to its simplicity of manipulation should become quite popular.

The second method which is a decided improvement upon the foregoing one, especially so since it may be carried on by either artificial or daylight is somewhat more complicated owing to the fact that some additional apparatus is required. Yet all accessories are so simple of construction that almost any amateur may make them, thus in a measure lessening this discouraging factor.

The materials required are the following:—

- (a) An 8 x 10 camera—Larger if Doré-types of greater dimensions are wanted.
- (b) About three yards of black material, fairly light proof if possible. (cover cloth.)
- (c) The shadow box. (See working drawing, Figure 1)



LILLIES.

F. WILLIAM CARTER.

Beginning with the shadow box which from the point of view of construction is perhaps the only portion of the entire apparatus which requires a little mechanical, yet not more than the average amount of skill, the amateur will find that he will have practically speaking, no difficulty in building this part. In detail it consists of an ordinary wooden box having four sides only. The size and general dimensions may readily be gathered from the drawings. Leaving the front of this box open, but closing the back-end of it with a nest of frames or kits so as to accommodate the various sizes of plates ranging from 4 x 5 to $6\frac{1}{2} \times 8\frac{1}{2}$ and larger if necessary, the entire contrivance is now given a few coats of dead black paint on the inside. (See Figure 1.)

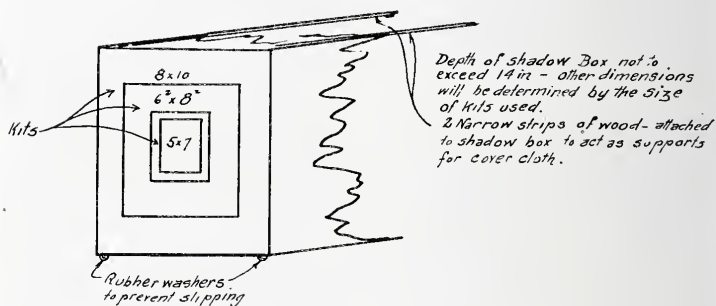

Figure 1.

In order to make the Doré-type, place the negative into the suitable kit and arrange the three units, camera, cloth and shadow box as shown in illustration, Figure 2. The illuminant for this process may be either artificial light or daylight. No matter which one of these two is employed extreme care should be exercised in having the light distributed evenly. Greater or less diffusion may be obtained by interposing one or two thicknesses of tracing cloth, or the same number of pieces of ground-glass. After these details have been carefully attended to, and everything is set up as shown in diagram (2) focus your camera. You are now ready to make your exposure which should be so gauged that the resultant negative will be of a rather thin quality, yet not be wanting in detail



SUNLIT WATERS.

Edward R. Dickson.

and snap. As a rule an exposure of from $1/5$ of a second to $1/2$ a second will be found quite satisfactory. It is of course essential to have the camera with as long a bellows extension as one can conveniently secure. The advantage of this will be readily seen, especially when one does portrait work and wishes to obtain large heads. As far as the lens is concerned almost any one of the standard types of good lenses will yield excellent results. I therefore leave the choice of this last named commodity to the selection of the photographer.

The last and perhaps the best method of making Doré-types is the one which is almost identical with the usual method of enlarging. All restrictions which were encountered in the previous processes are in this one completely eliminated. A point of major importance is that the entire work is to be

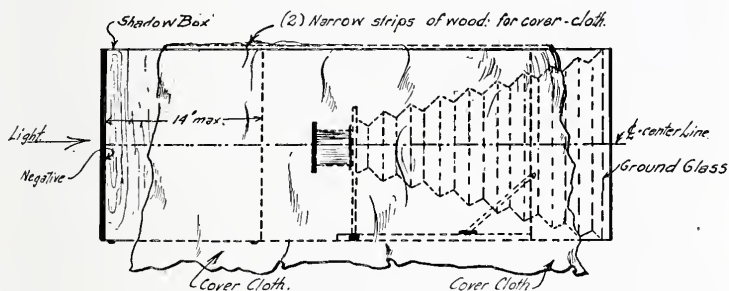

Figure 2.

carried on in either the dark-room, or in a room especially prepared for this purpose. As the plate, which is extremely sensitive, is handled more freely than in the ordinary photographic process, a safe light having the highest factor of safety should be employed.

After exhaustive experiments I have found that a safe light (electric) constructed on the following principles will be found most satisfactory: Build a rectangular wood or metal box, 8" x 14" x 6", into this box fasten an electric socket so as to receive an incandescent bulb. A 40-watt amber colored tungsten bulb will serve the purpose admirably. The front window of the lantern is constructed in the following manner: Take a sheet of ruby glass and a piece of ground-glass, and between them place one thickness of orange

paper, the kind that is used for envelopes in radiography, bind the three units firmly with passe-partout binding and the resultant combination is a safe light which will not veil a plate even after an exposure of 10 minutes. Inasmuch as the work is done entirely with artificial light, the greatest care must be exercised in closing or covering all crevices of the enlarger, which may during the process of manipulation emit white light so detrimental to this work.

Now that all preliminaries have been disposed of we are ready to make the exposure. Assume that we wish to make an 8 x 10 from an original which is 4 x 5 in. in size. After having placed the negative into the carrier of the enlarger, focus the image upon a piece of stiff white drawing paper which has been placed into an 8 x 10 printing frame. To keep this paper perfectly flat, and thus insure absolutely true focus, it will be found advantageous to place the above mentioned paper behind a clear piece of flawless glass. After focusing cover the lens with a cap of *ruby* glass and replace the drawing paper by an ordinary sensitive plate or film, emulsion side out. The ruby cap acts as a safeguard against veiling, and at the same time enables the operator to replace the printing frame after loading it, into the same position which it occupied previously. In order to avoid any possibility of halation due to refraction, interpose a piece of ordinary dead black paper between the hinged back of the printing frame and the plate. The composition as well as all other minor details having been verified we are now ready to make the exposure.

As the negative must be of a rather thin yet vigorous quality a great deal of care has to be exercised in gauging the time of exposure. As a rule when any one of the standard makes of fast plates is used 3 to 5 seconds will be found quite sufficient. This of course will only hold good when the negative (original) is of a type commonly known as snappy or crisp. Flat or severely over-time negatives, in general negatives which do not lend themselves well to enlarging, will as a rule not yield Doré-types of a satisfactory quality.

Development must at all times be carried on in Metol, or any one of its reliable substitutes now on the market. I found the following formula to give excellent results:



BEYOND.

FRANCIS ORVILLE LIBBY.

Water	76	oz.
Metol or substitute.....	60	gr.
Sulphite of Soda.....	2	oz.
Hydrochinon	1/2	oz.
Carbonate of Soda.....	1 1/2	oz.
Potassium Bromide	30	gr.

For use mix with equal parts of water. Keep developer at a temperature of 65 degrees. Should more bromide of potassium be required, add one drop of a saturated solution to every four ounces of developer. Carry development far enough to be able to distinguish detail in the shadows. The exact time or point at which to discontinue the process of development will best be determined by actual experiment. If development is prolonged too far the final color or tone of the Doré-type will be affected. That is to say it will either be too dark, or it will present a mottled appearance. After development fix plate in strong acid hypo acidulated with No. 8 acetic acid. Should this, however, not be available, an acid bath made up with citric acid will well serve the purpose. After fixing wash the plate for about 30 minutes in running water and re-develop by the sulphide toning process. I have found the following re-developer to produce beautiful tones:

BLEACHER Stock—Solution.

Water	64	oz.
Potassium Ferricyanide	1/2	oz.
Potassium Bromide	1/2	oz.

For use take one ounce of stock solution to every two ounces of water and add one drop of strong ammonia for each two ounces of dilute solution.

RE-DEVELOPER

Water	8	oz.
Sodium Sulphide	1/2	oz.

For use take one ounce of re-developing solution and add fifteen ounces of water.



RAY.

HERBERT IRONS.

After the image has completely been bleached out in the bleaching solution remove and rinse thoroughly. Then place into the re-developer and leave therein until it regains its former strength and brilliancy only that the black and white tones have been turned to a sepia tone. A final washing is then given to the Doré-type for about half an hour and then set aside to dry.

Beautiful effects may be produced by taking the positive thus produced and backing it with either gold or Indian tinted card-board or paper, backing this combination with a piece of glass and binding the three units with passe-partout binding.

Instead of the sulphide toning bath any one of the following toning processes may be employed.

After washing place the plate into a mordant made up as follows:

Water 1 oz.

Chromic acid, $2\frac{1}{2}$ grains to every ounce of water.

Red prussiate of potash, $2\frac{1}{2}$ gr. to every ounce of water.

Leave in this solution for about 2 to 4 min. After this time bleaching should be complete.

Without further washing immerse plate into a 10% solution of sodium bicarbonate, leaving it therein for about 5 minutes. Wash for 5 to 10 minutes.

For the purpose of toning take any aniline dye (this must be a basic dye) and make up a solution as follows:

Water 1 oz.

Dye 1 gr.

Acetic acid, No. 8 (28%).....

.....one drop to every ounce of color.

Immerse the plate in this solution and leave therein until well colored. A good way to judge whether the process of toning has advanced far enough is by the density of the color in the margin of the plate. Wash for 30 minutes and dry.

This method of toning, which is applicable to films as well as plates, will give the photographer an unlimited field in which to work. This will enable him to obtain results which in artistic beauty have so far been unrivaled.



THE SUN'S DESIGN.

MARTIN VOS.

IN SEARCH OF THE PICTURESQUE

By J. E. ADNAMS



WHAT is the meaning of the picturesque? The definition usually given is "worthy of being pictured" but as a definition that is scarcely correct. There are many things worthy of being drawn or photographed that cannot be said to be picturesque. The portrait of a dear friend may be well worth taking although the only beauty he, or she, possesses is the beauty of soul and character. The birthplace of a great man may be anything but picturesque, and yet worth taking for its historical interest. Numberless incidents in the Great War were well worth taking and publishing in the papers, although not one in a thousand could be called picturesque.

So it seems that a better definition would be "that which will make a good picture."

Sometimes people are struck by an incident which is full of pathos, or humor, or some other interest, and they at once say "What a good picture that would make!" It does not follow that it would, unless it fulfilled the requisite conditions for a good picture; pictorial suitability is quite independent of the sentiments of the scene, and of the feelings invoked although it is quite possible that picturesqueness may exist together with the sentiment.

A picture should agree with the rules of composition although as photographers we do not compose it in the sense in which a painter does. The study of composition enables us to see what is picturesque and avoid taking what is not; and having chosen our subject it will help us to select our standpoint, and effect of light and shade, will tell us whether the introduction of figures will improve or mar the picture.

There seems to be some inherent connection between old age and picturequeness. The finger of time tones down what is glaring, gives variety to surfaces, rounds off the sharp corners, and generally makes things look picturesque and more in har-



OLD BRIDGE—LUCERNE.

J. E. ADNAMS.

mony with Nature. A new brick wall, for instance, with every brick truly laid and every joint a perfect straight line, may be a thing of beauty and pride to the builder, but to the artist it is ugly and staring, and only when time and weather have knocked it about and stained its surface with lichen, clothed it with ivy or planted wild flowers in its crannies, does it become picturesque.

Many of our disappointments in the search for the picturesque arise from the fact that beautiful things in Nature do not always make beautiful pictures, however we may treat them. We are apt not to realize, for one thing, how much is owing to the charm of color, and when our picture is translated into monochrome we find the beauty gone. For another thing, we view a scene with two eyes and get a stereoscopic effect, each different plane of the picture standing out boldly in a way it would not do if we used only one eye. The camera having only one eye misses that stereoscopic effect and the result is a disappointment.

The subject of composition is dealt with in most of the handbooks on drawing and sketching, but from the photographic point of view the simplest and most practical treatment is in Horsley Hinton's book on Pictorial Photography. If we photograph natural history subjects such as birds and their nests, views of places we have seen in our travels, houses and streets connected with historical events, or if we snapshot prominent public personages, we may get intensely interesting records, but only seldom real pictures. If we are out for securing the picturesque it is best to ignore the interest and sentiment of the subject and concentrate our attention on the light and shade, the direction of the lines, the contrast and harmony, and aim at producing a picture which those who look at it will admire for its own beauty, and not care to ask where and when we took the negative.



THE FERRYMAN.

J. E. ADNAMS.



Illustrating article "Economics in Portraiture," by T. W. Kilmer.

ECONOMICS IN PORTRAITURE

By T. W. KILMER



THE 8 x 10 plate is recommended, and is the one usually used by me in most all of my portrait work; yet in these times of saving and high taxes economy is of paramount importance.

Two small, sharp-focus negatives can easily be made upon one 5 x 7 plate. These negatives are to be made



Illustrating article "Economics in Portraiture," by T. W. Kilmer.

as sharp as is consistent with your lens definition. A little retouching will be necessary because the anastigmat is no respecter of lines, wrinkles or blemishes.

In retouching, be careful to do it as neatly as possible, for it must be enlarged and irregularities may show in the finished print. Enlarge these small negatives through a soft-focus lens stopped down a little. Personally I use Artura Carbon Black paper for any portraits made in this way.

In beholding the results, one will oftentimes be very agreeably surprised at the atmosphere and depth obtained in the finished print. While I am a very firm believer in using 8 x 10 plates and making contact prints from the original 8 x 10 soft-focus negative, I know that results may be obtained in portraiture by enlarging the small anastigmat negative, which results are a very close second when compared with the contact 8 x 10 prints. Any way, it is a means of practicing strict photographic economy, and the results are certainly worth the small means expended.



THE WHALERS.

S. B. RISDON.



SITE OF THE LAST CAMP FIRE.

W. G. ADAMS.

PRINCIPAL FAULTS OF PRINTS SUBMITTED FOR PUBLICATION

By J. E. CARSON



THE fault with nine-tenths of the prints sent in for criticism or publication is "soot and white-wash"—the print of chalky high lights and dense black, detailless shadows, due to undertiming and over-development. The undertiming is due to the fact that the operator has not become familiar with his camera, does not use a meter and does not use his head. Over-development follows undertiming as does the night the day. The operator tries to produce something that does not exist; carries his development too far, with the resultant print of excessive contrasts, which jars.

A camera, even the cheapest box, is not a toy. It is a scientific instrument, capable of magnificent work. But it requires much more than "pressing the button" to get Salon results; brains are essential.

Fault No. 2 is lack of unity in the print. Ignorance of laws of composition is chiefly responsible, but the oblong style of camera, such as the amateur favors, lends a helping hand. Even an expert finds it hard to unify his picture with this style camera, and depends upon trimming, masking and enlarging to get his real picture. Nearly all amateurs desire to include everything in sight in their pictures. They do not know art or care for criticism; they do know what they want, get it, are satisfied, and who shall say them nay! Perhaps they get more satisfaction and pleasure out of their results than the pictorialist. Everyone to his taste! The photo business would not have reached its present position of prosperity and prominence had it depended upon the serious worker. Artist and manufacturer owe the amateur and his faults a debt of gratitude.

Distortion may be cataloged as fault No. 3 in our list. Under this head may be included exaggerated perspective, fore-shortening, etc., all of which is due to the desire to make



PORTRAIT.

Edward Weston.

a picture too large for the focal length of the lens to handle in the way that the eye sees things. We are all familiar with prints of children (especially) where the feet, legs and hands would be suitable for a giant; a horse or other animal with a head larger than its body; a building with its lines coming to a point within the picture space. Remedy: curb the desire for the big picture in a small space; enlarge the little picture.

Fault No. 4. Using the wrong printing paper for the negative. Few amateurs realize the importance of using right grade and surface of paper. Often this makes or mars a picture. The negative may be capable of giving a fine print on one grade and surface of paper, and the result would be failure if another grade or surface of paper was used. All camerists should have and use three grades of paper, viz.: "Contrast", "Normal" and "Soft". Study your negative and know which grade to use. It is wonderful what differences can be made by selection and use of the printing paper. Try it.

Fault No. 5 deals with technical faults, such as over or under-development, fogs and stains. These result from inexperience and carelessness in handling the prints in the dark-room, and the remedy is apparent. A timing piece, fresh solutions and working at prescribed temperatures, which requires the use of a thermometer, work wonders right here. One cannot be too careful, especially in hot weather.

Fault No. 6 deals with composition. Few amateur pictures have proper entrance or exit "lines", and many an otherwise fine print is marred thereby. Sometimes the entrance is blocked (even a misplaced shadow will do this), and the eye must seek an entrance along the sides, perhaps to be carried right out of the picture without entering it. Roads, paths, streams, shadows, inclination of trees, limbs, branches, twigs, weeds, etc., have to be dealt with and handled so as to emphasize and carry out the idea of the operator.

Fault No. 7 is a fault not near so frequent now as in the past; we do not see so many evidences of the camera being held out of plumb. Houses falling backward, or converging to a point are not so numerous as formerly. Think the improved finders have done lots to eradicate this evil. The different "movements" of the front, back and beds of cameras are a great help in avoiding this fault, and a tripod has its

uses right here. These faults can be overcome entirely in enlarging from such negatives.

Fault No. 8 is rather a common fault, but is not so noticeable to the general eye. Very few prints from amateurs have the principal object of the picture placed just where it should be; this object is generally too near centered, and the center of a print is its weakest point in most cases. This evil must be studied to be overcome. Any good book on "Composition" will do the work, if its rules are followed, and they must be before any amateur or professional can enter the pictorial ranks.

Fault No. 9. We will combine under this head the few remaining minor faults, such as cutting off the heads and feet of the main object; lack of balance in the composition; too much blank sky space; horizon line bisecting the print. (This fault is general in reflection pictures.) Space is too limited to go into details of these faults, and we will pass on to a few concluding remarks

We strongly advise all amateurs to use a meter; so doing will reduce expenses and give a satisfaction unthought of. Any photographer who does his own finishing can improve his work by the use of a tank. This method, used as directed, will give all there is in any negative better than the tray method will do. What the tank fails to produce has not been recorded. Give the meter and tank a trial. You will never regret it.

"Anything worth doing is worth doing well." In no art or science is this truism more applicable than to our beloved photography. Nowhere are its truths more apparent or easier to demonstrate. A study of this charming and delightful art will be pleasant, instructive and beneficial. It will make all work connected with it a delightful and fascinating pastime—something that will drive away dull care and revive drooping spirits. The resultant pictures will always be a source of pleasure and satisfaction to us and our friends, a delightful reminder of days gone by, that will "Carry On" to those following us valuable information and priceless pleasure.

Photography is something to be proud of; it is a science and an art worthy of anyone's time and cultivation. .



THE LOGGER.

H. V. SCHIEREN.

THE CAMERA AND THE MICROSCOPE

By J. A. ERNEST ZIMMERMANN, B.S.



HIS abstract is taken from two papers read before the Thomas C. Porter Scientific Society, F. & M. College, Lancaster, Pa. 'The Development of Photography,' February, 1917, and 'Researches on the Silver Halogens,' January, 1918."

It seems that few articles appear to-day in regard to photo-micrography, and those only in scientific publications. Before treating this subject I should like to clear a few mistaken expressions for the readers of the *Annual*. There is a great difference between "Photo-Micrography" and "Micro-Photography" and yet the two terms are used interchangeably. A "Photo-Micrograph" is a photograph of a microscopic object, while a "Micro-Photograph" is a photograph which is very minute. The "Micro-Photograph" is usually a negative which is used for projection purposes while the "Photo-Micrograph" is usually a photograph used for illustrating the minute structures of cells, bacteria, etc., in the enlarged condition to the human eye.

The use of the microscope and camera is becoming more popular in scientific circles. Thus we see the biologist using it to prove his mutation theory, Mendel's law, etc., by means of photographs taken with the aid of the microscope. The chromosomes (color bearing bodies of the nucleus) are shown in striking contrast in the four phases; i. e., the embryos of the animal are taken from the body at the different stages of development, sectioned, stained and then photographed. In this manner the biologist can study and at the same time prove the most minute structure of the living cell in detail.

Not only does the "Photo-Micrograph" benefit the biologist, but also the teacher. How can a child be made to realize the germ or bacteria? You cannot give him a microscope, but you can show him the photograph taken and thus impress the youthful mind.



GERTRUDE H.

CHAS. L. SNYDER.

But we are not to stop here. The chemist does not only make use of the microscope in the examination for the detection of adulterants in food, but he takes photographs of the chemical pure materials and then compares the material under investigation with these photographs. Thus he examines flour supposed to consist of pure wheat. First of all he has his "Photo-Micrographs" made of the different starches (for the granules of each starch are entirely different), and that of wheat starch must correspond to the wheat flour under investigation.

Not only is it used for the detection of adulterants, but also for the examination of the structure of certain crystals (crystals all possess a certain structure which is always referred to a geometrical pattern). Thus in "Dana's Mineralogy" we find the silver chloride and silver bromide placed under the isometric system (i. e., having three axis of the same length at right angles to each other) yet after these crystals were photographed, they showed no isometry (see Photo-Micrographs), and among some three thousand crystals which were very minute not a single isometric crystal, neither cube nor octohedron, appeared.

Thus the camera and the microscope are being put to more use every day and the scientific world is realizing the value of both instruments in connection with each other for its instructive values as well as the tremendous value of the "Photo-Micrographs" produced.



*"They rest from their labors,
but their works follow them."*

HERBERT WHEATON CONGDON.

THE GRAFLEX FOR PICTORIAL WORK

By PAUL L. ANDERSON



It is not the writer's intention to adhere closely to the subject indicated by the title of this article, but to use it, rather, as a text on which to base a discussion of certain types of apparatus and certain methods of work which he has found useful in his own efforts at picture-making by photography.

At the outset we must distinguish between two classes of pictorial photographer, between two distinct and separate types of mind, for practically all workers of the present day will fall into one or the other of these classifications, and the apparatus and methods most adapted to the types are widely different. First, then, we have the slow, deliberate worker, preparing carefully for the picture he intends to make—perhaps even drawing several preliminary sketches of the proposed arrangement—and, after extensive thought, photographing the subject he has decided upon, whether it be a landscape, a genre, or a figure. This type of photographer as a rule is more concerned with esthetic effect than with pictorial expression; pattern, print quality, surface texture, are to him of more importance than the intellectual message which the finished work is to convey, and for this reason, as well as because composition is more easy with a large focussing screen, he elects to employ a large camera, $6\frac{1}{2} \times 8\frac{1}{2}$ or 8×10 , and to print direct, since print quality is at times lost in the process of enlarging. Also, size means little to him, for one can be as esthetic in 4×5 as in 20×24 —often more so; enlarging shows up faulty composition most distressingly. Further still, this type of worker usually prints in platinum, that being regarded as the most esthetic of printing media, and the act of enlarging then involves two intermediate operations, with consequently increased opportunity for loss of print quality. For such workers, for individuals of this mental attitude, there can be no



THE FAIRIES' STAGE.

O. E. Fischer, M.D.

question that the best outfit is a large camera of the view type, the few negatives being developed individually—the tank represents no economy of either material or labor for two or three plates—and the prints being made in platinum or its equally desirable successor, palladium. And since these workers are concerned chiefly with light effects, pattern, atmospheric manifestations, and the like, they are generally opposed—and logically so—to more than very slight modifications of either negative or print by means of hand work.

The other class of pictorialist, however, is more impulsive, more prolific of ideas, and prefers to make a considerable number of negatives, selecting from among them the one which most nearly expresses the idea he wants to convey, and modifying by hand if necessary in order to carry his message. He chooses rather to do his selecting at leisure, from a number of prints, instead of making decisions hurriedly under the nervous tension of field work, and since his primary desire is pictorial effect he regards esthetic merit simply as a means to an end, not the end itself; as part of the language he employs to convey ideas rather than a complete work in itself. He therefore uses (on account of portability and convenience in the field) a small camera, exposes a number of plates from approximately the same point or under approximately the same conditions, develops them—as a rule—in a tank, and makes contact prints, selecting from these and discarding all but the most satisfactory of the negatives. Since pictorial effect depends to a great extent upon size, he enlarges, often to very great dimensions, and since the artist, limited by his medium, must resort to artifice to convey his message, this worker seldom accepts nature as he finds it, but introduces modifications of light or line to produce the effect he intends.

It is not the writer's intention to say that either of these methods or either of these attitudes of mind is superior to the other; they are merely different, though it is perhaps within the truth to say that since the primary purpose of fine art is to convey ideas it seems probable that the worker whose fundamental motive is pictorial effect is more likely to produce lasting works than the one who is actuated by mere estheticism. It is, however, unquestionably the case that the modern tendency in art is toward estheticism and away from imaginative

work, a distinction which is emphasized by the difference in approach found on the two coasts of this country. In the highly sophisticated East the attitude is largely favorable to pure estheticism, whereas in the freer, less conventional West pictorial effect is more aimed at, though there are, of course, notable exceptions in both areas, the rule being by no means invariable.

The writer has held both attitudes; for some eight years after first beginning pictorial work his tendency was in the direction of the first school, his every effort was toward estheticism, his study was of pattern, print quality, texture, and the other factors which go to make up the work of this class of photographer, and he admits freely that the training thus secured was valuable in the extreme. But he gradually became impatient of what seemed to him the futility of such work, work which, admittedly beautiful, gets nowhere, says nothing of importance, and is comparable to a poem which, exquisite in rhythm and music, is nevertheless slight in thought. He therefore found himself tending toward the other school, and though for the past three or four years his opportunities for photographic work have not been so extensive as might be, he has nevertheless been able to reach certain conclusions as to useful apparatus and methods. Before turning to the more concrete discussion, however, he would point out the dangers inherent in each of these attitudes of mind, the tendencies which are likely to minimize the artistic effect of the results secured. The danger of the first school has been already suggested; it lies in the fact that the worker may become interested in pure estheticism and, finding it easier to secure an effect thus (for pattern and print quality and texture may readily be learned) may be reluctant to make the effort of imagination requisite to pictorial effect, and may come to rely exclusively on the sensuous appeal of a beautiful print, thus placing himself in the class of literary stylists who "say nothing, very beautifully." On the other hand, the one who is concerned for pictorial effect, for the conveying of an idea, may too easily come to despise esthetic merit, and may eventually find himself in the position of one who, having a message to give, is unable to deliver it because he does not know the language. The best way to guard against either of these faults



APPLE TREES.

PAUL L. ANDERSON.

is to cultivate a sincere and honest interest in the work of members of the other school, trying to see the merits even in works which do not, as a whole, appeal to the student considering them.

Taking up now the question of apparatus, we may say that but few pictorialists, of either class, will voluntarily work with a camera which lacks a focussing screen. Some indeed, after considerable practice, will be content to do so, but, as a rule, the miniature cameras, folding film instruments, and the like, will be employed only for record work, when traveling, and so on, for the convenience of a ground-glass the size of the finished print is undeniably great. To the worker who aims at estheticism the inversion of the image on the screen of the view camera is a defect of no importance—it may, in fact, be a help, since pattern is then considered apart from any disturbing influence of pictorial effect—but to the worker who aims specifically at pictorial results, at the conveying of an emotion, it is of great value to have the image right-side up, and this is attained only in cameras of the reflex type. Further, the design of these instruments is such that a number of plates may be carried in a magazine, or a number of exposures in the form of roll-film may be taken along, and this also is of value, for, as has been pointed out, workers of the second class usually wish to make more exposures in the course of a day's work than is the case with those of the first class. It is admitted that cameras of this type are exceedingly cumbersome and heavy in the large sizes—almost impossibly so when larger than 5 x 7—but this is by no means true of the smaller ones, and to the photographer who wishes to enlarge from his originals a small camera is as good as a large one, provided always that it is not so small as to prevent differentiation of planes by focussing, a fault which manifests itself with short-focus lenses. An additional feature which is of great merit in some instances is the fact that with the reflex camera it is possible to watch the image up to the instant of exposure, no time being lost, as with the view camera, in placing the plate-holder in position. This feature is of no particular interest in landscape work but in marine work it may be, and when it is a question of portraiture of children—indeed, portraiture of any kind—it is of so great value that the writer, after several

PAUL L. ANDERSON.

THE LITTLE WHITE HOUSE.



years' experience of both methods of work, would be exceedingly reluctant to abandon the reflecting camera for any other type. It is possible to obtain reflecting cameras with long bellows—18 inches in the 4 x 5 size—revolving back, and very large front-board, so that these features, in combination with the instant exposure, the non-inverted image, and the ease of examination of the subject—it is no small matter to struggle with an 8 x 10 view camera and focussing cloth on a windy day!—as well as facility of transportation, combine to make the reflecting camera well-nigh ideal for workers of the second class. It may be objected that the reflecting camera has not the swing-back, and to this the writer can only reply that he has never felt the lack of this adjustment. It is desirable—even necessary—in an 8 x 10 or $6\frac{1}{2} \times 8\frac{1}{2}$, but in 4 x 5 or $3\frac{1}{4} \times 4\frac{1}{4}$ its absence does not interfere in the least with serious work.

The next question is the matter of size, the plate which is to be used, and as has been said the reflecting camera becomes prohibitively bulky and heavy in sizes larger than 5 x 7, and even in that size is too heavy to carry comfortably for a day's field work. On the other hand, if plates smaller than $3\frac{1}{4} \times 4\frac{1}{4}$ are used the short focal length of the lens most suitable prevents satisfactory differentiation of planes, and the small area of the focussing screen interferes with ready judgment of the composition. Further, the proportions of the 5 x 7 are not good; the plate is too long for its width, and the same is true to a greater degree of the $4\frac{1}{4} \times 6\frac{1}{2}$, as well as of the post-card size. On the other hand, the 4 x 5 errs in the other direction; it is too wide for its length, and the most satisfactory proportions are those of the $3\frac{1}{4} \times 4\frac{1}{4}$ (which, of course, are the same as those of the $6\frac{1}{2} \times 8\frac{1}{2}$). But this plate is rather small for ready field work, and the writer prefers to accept the slightly unsatisfactory proportions of the 4 x 5 for the sake of the increased ease in the field and in selecting from among the proof prints, as well as for the reason that one often wishes to make permanent and esthetically pleasing prints from negatives which do not, on the whole, merit enlargement; there are subjects one wishes to preserve for their sheer sensuous beauty, even though they may carry no message, may possess no emotional quality. So the writer's conclusion is that for the



WILLOWS.

PAUL L. ANDERSON.

pictorialist of the second class no better instrument is available in this country (though there are better ones made in England) than the 4 x 5 long focus revolving back Graflex, and it is with a camera of this type that 99% of his present work is done, the 8 x 10 view camera and the 4¼ x 6½ Kodak and the 6½ x 8½ Century being called into service only on rare occasions.

With regard to the lens, the writer has experimented with every type of objective available in this country; with rapid rectilinears, anastigmats, single achromatic, portrait lenses, and with every make of soft-focus objective, and has reached two conclusions as a result. The first is that it is better to employ a soft-focus lens in making the original negative than to make the original sharp and depend on subsequent manipulations for a pleasing diffusion; the second is that he prefers the Struss single lens to any other. This objective is extraordinarily light, which is no small matter in field work; its quality of diffusion is more readily under control than with any other; it is very fast; and it comes nearer than any other to possessing that quality admired of all workers, of "softness without mushiness." To be sure, almost any soft-focus lens may be made to give this quality, but the Struss will do it at full aperture, no small advantage when portraits are to be made. The Struss lens is ordinarily designed to work at F/5.5, but the writer, finding the front-board of his camera large enough for the purpose, had a special 9-inch lens designed to work at F/4.5, and at slight additional expense secured two supplementary lenses of 12 inches and 15 inches focal lengths respectively, which can be inserted in the barrel in place of the 9-inch glass, in a few seconds. The 12-inch works at F/5.5 and the 15-inch at F/7.5, but the 9-inch (the ideal all-around focal length for a 4 x 5 plate) is probably used fifty times to once of either of the others.

The writer has elsewhere expressed his opinion in the much-debated matter of plates *versus* films* and will here remark only that his almost invariable preference is for a fast, non-halation panchromatic plate, which will do, in landscape, all that any other will do, and in portraiture much more. The

*"Pictorial Photography, Its Principles and Practice," Chapter III.



A BERKSHIRE PASTORAL

Rudolf Eickemeyer, M.R.P.S.

only draw-back to such a plate is that it must be handled, until after development, in total darkness or by the aid of a green light so subdued as to be of little assistance, but this is, actually, no draw-back at all, for one easily learns to load plate-holders, magazine, and tank by the sense of touch, and the writer finds that such plates, if rinsed in six or eight changes of water after developing, may be taken from the tank and placed in the hypo in a bright yellow light, without fogging. Or, if plain hypo, freshly mixed, is used (as should always be done, anyway) the plates may be fixed in the developing tank without harm to plates or tank. The plates the writer finds most satisfactory for all-around work are the Wratten Panchromatic, which may be purchased backed and consequently non-halation, the backing being removed after fixing, by means of a tuft of cotton and a stream of water. The writer has had a great deal of difficulty in obtaining these plates free from edge markings (which extend sometimes an inch or more in from the edge) in the 8 x 10 size, but has never had any such trouble with the 4 x 5. In conjunction with these plates a Cramer Isos III filter is almost invariably used, the reason for choosing this in preference to the K₃ filter of the Wratten series being that, in trying the combination on a test chart, the Cramer filter seemed to render the yellow a trifle lighter than its true value, and since yellow is a color of strong psychic effect, this seemed desirable in pictorial work. The Cramer filter, of course, could be expected to render the precise photometric value of all colors when used with the plate for which it is designed. This is a five times filter with this plate, and the exposures are consequently quite within reason. Incidentally, this seems a good place to remark that the terms so often heard, "five times," "ten times," and so on, mean absolutely nothing unless the plate also is designated, for it is quite possible for a filter to be a five times for one plate, a ten times for another, and a fifty times for a third; the filter may pass only those rays to which the plate is relatively insensitive. Thus, the writer's rough tests seem to indicate that the Isos III filter is a five times for the Wratten plate and a ten times for Eastman film, and that the Isos II filter is five times for the film.*

*These figures must not be taken as precise; they are at best only a rough approximation.

It is the writer's custom to carry a light tripod, though it may appear absurd to do so with a Graflex, this being so widely advertised as a high-speed instrument. However, many of the writer's exposures are of the order of $1/5$ second, being made with the "slow snap," when the jar of the mirror ordinarily precludes holding the camera in the hand. There are several things which combine to cause such long exposures; photographing toward the light; photographing late in the day, or in poor light; using a ray-filter; and, not least, the desirability of full exposure in pictorial work. In news photography slight under-exposure, with consequent loss of detail in the shadows, is not ordinarily serious, but it usually is in pictorial photography, the value being thus upset. The exposure tables and actinometers are calculated to give the minimum exposure which will render detail in the shadows, but even so detail is secured before the exposure is sufficient to throw the whole negative within the straight portion of the Hurter and Driffeld curve, this being the index of correct relative values. Of course, it sometimes happens that under-exposure is desired for pictorial reasons, but the writer feels it generally better to produce a normal negative and depend on subsequent modifications for the desired effect.

If one desires to produce a number of normal negatives, from varying subjects, for later selection, modification (perhaps) and enlargement, there can be no question as to the value of the tank for developing. It represents no economy of time when but one or two plates are to be treated, but if half a dozen or more are in hand at once it assuredly does, not to mention the great advantage resulting from the decrease of the time spent in the devitalizing dark-room. The writer has secured two admirable daylight tanks (imported from England) and is able to retire to any closet for the ten minutes necessary to load the plates into these tanks, all subsequent operations, up to setting the plates up to dry, being carried out in full daylight—in summer, out of doors. It has been shown by physiologists that working in darkness or by artificial light—especially red light—lowers the vitality, and from the simple point of view of physical welfare the tank represents an advance on development by inspection, quite apart from the fact that a better average of negatives is thus produced. Develop-

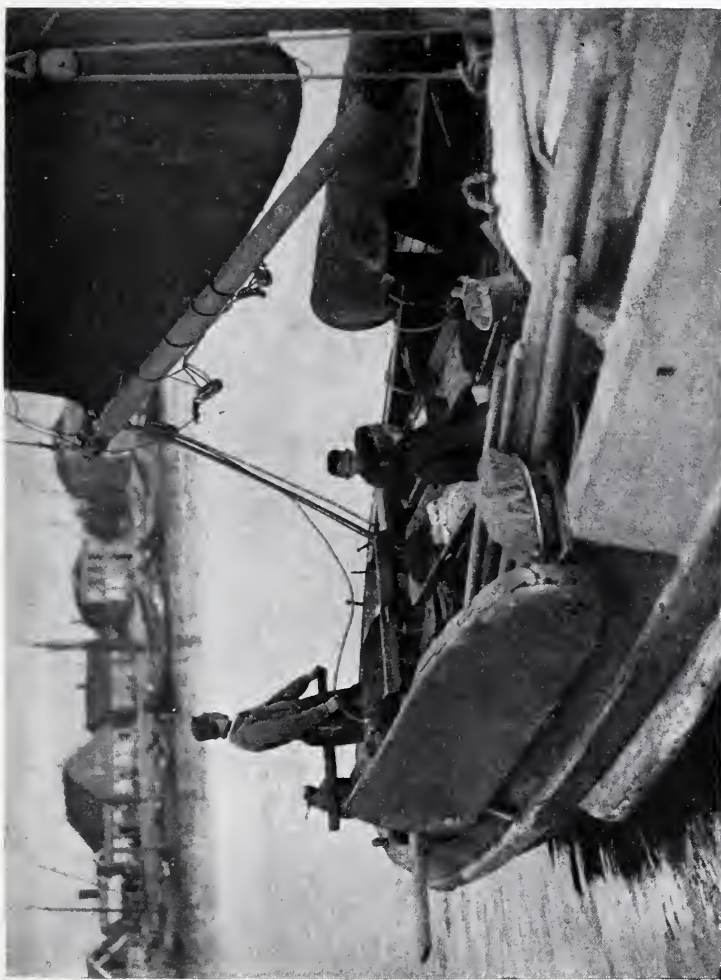

ADIEU.

THOMAS CARLYLE.

ment by inspection depends on individual judgment, which is modified by varying conditions, by haste, excitement, even by the varying length of time in the dark-room, and anything which eliminates this source of error tends to produce better results. The writer, even if working for varying qualities of negative, would still prefer to do the original developing by tank, relying on subsequent intensification or reduction, carried out in leisurely fashion in daylight, for the desired changes, and feeling confident of thus securing better negatives than by varying the time of development under dark-room inspection. It might be well to mention that the writer developed all or nearly all his negatives by inspection for a number of years, before adopting the tank, and has consequently had liberal experience of both methods. As to the developer used, several years of experimental work with practically every reducing agent on the market have resulted in the conviction that *so far as final results are concerned* it makes not one particle of difference what developer is used. The same end-product can be obtained with any organic reducing agent as with any other, and the choice is purely a matter of convenience and economy. It is true that there is some difference in convenience; thus, it is easier to secure a strong negative with a short-factor developer such as hydroquinone than with a long-factor agent like metol, and *vice versa*, but these differences are minimized or eliminated in the tank and practically the only choice lies in ease of preparation. There are, of course, persons to whom dark-room work appeals as a form of diversion, and to these the tank and all its associations are anathema; they develop their plates by hand because they get a thrill from watching the gradual appearance and growth of the image, but those workers who are concerned solely with the finished print, to whom the mechanical part of photography is, precisely, mechanical, welcome the tank as minimizing the time which must be given to the machine part of the work, for development is not a process requiring artistic feeling, or even a high degree of intelligence. The men who claim to be able to vary results by varying development deceive themselves; it is impossible to vary relative contrasts after the shutter closes except by hand work, and total contrast can be varied more easily and surely by reduction of intensification.



SENTINELS.

W. S. WHITE.

We come now to the most-debated and least-decided question in pictorial photography—hand work. One man will claim that it is legitimate to employ local or general reduction or intensification but is altogether wrong to use a pencil on the negative; another will pencil his negatives freely but revolt at the suggestion that he brush-develop a gum-print; and a third may spray a gum-print with water but rebel when invited to hop the ink from an oil. The writer's feeling is this: Pure photography is a mechanical art, it is the product of a machine, and however beautiful, however exquisite, must inevitably lack the vitalizing touch of the hand. It is not that the writer imputes any magic power to the human hand; it is merely that the artist is so limited by his medium, by its lack of color, by its relatively short scale of values, by its lack of motion, and by its inevitably small scale of reproduction, that in order to convey a message, to arouse an emotion, he must resort to artifice, to falsification of values, to revision of line or mass, or to other variation from actual fact as seen by the machine. Failing this artifice, the spectator is left cold; he may find the result beautiful, but it arouses in him no emotion—its appeal is purely to the senses. Therefore the photographer, the painter, the sculptor, the etcher, who aspires to be more than a mechanical reporter of nature's beauties—and a reporter in a sadly limited medium, a sadly halting speech—must be prepared to resort to every means at his command to modify the mechanical record of the camera. It is not advised to modify recklessly or for the mere sake of modifying; each step must be carefully considered, must be taken in accordance with the dictates of sober judgment, and must have a definite purpose, or the final result may easily be worse than if no modification whatever had taken place; but something of the artist there must be in the picture, something to say: "This is no mere record of fact, but a message from one human soul to another," nor can this element ever be infused into the picture by a machine. This enthusiasm for pure photography, this reluctance to alter the productions of the camera, this deification of a soulless machine, is in no small measure responsible for the sterility of the present-day exhibitions of photography, a sterility which gives a visitor the feeling that he has seen it all before, that he does not care to see it again, that it is all futile



THE HEART OF THE BUSH.

ARTHUR DARING.

in the extreme—and causes him to halt in delight when he by chance comes on perhaps one real picture, perhaps two, in the midst of an arid waste of machine-made records—beautiful records, to be sure, but merely changes rung on a worn-out theme.

Finally, we have the question of the best printing medium, and here no advice can be given; we have left that portion of the art of photography which is mechanical and entered the realm of fine art, of individual expression. One man will find his best medium to be platinum, another gum, another bromide, another oil—the worker can but try each and settle on the one best suited to what he wishes to express. The present writer has tried them all and has finally settled on bromoil, which, in its power of darkening or lightening values, of varying contrast, of varying texture, and of giving rich darks, approaches nearest his ideal. One fault it has, the difficulty of working in large sizes, and this has led the writer to limit the size of his prints to 11 x 14, though other considerations would dictate a larger size. But, taken all in all, it comes nearest to what the writer feels a printing medium should be—but others need not feel the same. Each worker must choose for himself, exactly as each must decide for himself what method he will follow to introduce the human element into an art which is founded on the work of a machine; one can speak with authority only when dealing with matters that are capable of demonstration, not when discussing those that must ever remain a question of feeling, and the most the writer can hope to accomplish in an article like this is to point out the danger of pure estheticism and to suggest methods which will lead the worker away from that danger and into the path of what seems to possess the elements and the potentialities of a great and noble art.



FLOWERS OF SPRING.

RUPERT BRIDGE.



C. W. DOUTT.

SEEING AND FEELING

By GUY SPENCER



CLASS in photography, rambling along the country-side in quest of atmosphere stopped in front of a miniature water-fall. It was a modest stream of water making its way sedately down a barren hill-side, apologetically washing over slippery and shiny stones, with never a sunbeam to play among its drops. One of the workers, evidently thinking a fall of water, no matter how unpretentious, must have artistic possibilities called out to the instructor:

"Is this a picture or a record?"

"A record," came the reply, "Pass on." And herein lies a difference in photography where one records what he sees, another expresses what he feels.

In the old days photography was hampered by mechanical difficulties and perplexities; but with time have come such



IN THE DOLOMITES.

LOUIS J. STEELE.

appliances and processes as make of the modern lens an instrument of far-reaching adaptability.

The photographer once having learned his craft is free to devote his energy to the attainment of the beautiful. Yet with the same equipment, and a like environment, two workers will achieve totally different results; not because one has a better control of his medium, but by reason of the finer manifestation of feeling. They look, let us say, upon a gnarled old tree, "a blighted trunk upon a cursed root. Yet lifting its huge bulk by a seeming determination, and sending a green and leafy branch toward the sky." One views it simply as a bent, old tree and thus depicts it. The other feels the deep, underlying mystery, the unseen battle with a destroying force. To him it typifies the struggle for life, and he so infuses his work with the poetry of his conception, that the onlooker, with emotions stirred, is induced to think and dream, so strong is its appeal.

In portraiture too, is this manifest difference between seeing and feeling. One man portrays his models as they appear to him, making a mere "map" of their faces, but losing the deeper significance of character. The other perceiving the larger attributes renders the portrait with a delicacy and a convincing suggestiveness of individual personality. To the outward figure and features is added the inward grace.

Whence comes this difference, this feeling for the aesthetic charm of things? Is it not the outcome of self-development, and is not self-development a personal growth subject to the will? Once the desire for the beautiful—the true—is firmly implanted, it can be so guided and cultivated by endeavoring always "to reach through the fact to the soul within the fact," that the goal of achievement will ultimately be attained.

So taking photography as a means of expression, whatever the theme, be it the forms of men and women, the beauty of design, the brilliance of sunlight, or the "sombre cloak of shadow," to the cold principles of technique must be added the warmth of the spirit. For in the words of Leonardo da Vinci: "Where the spirit does not work with the hand there is no art."



EDGAR N. POOLE.

SUNLIGHT.

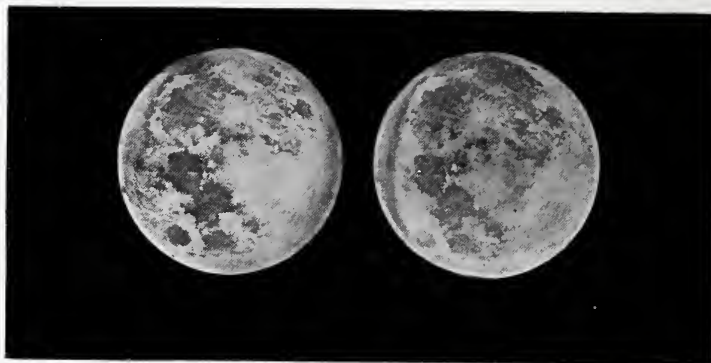

FULL MOON.

Illustrating article "Stereoscopic Photography," by H. W. Hales.

STEREOSCOPIC PHOTOGRAPHY

By H. W. HALES

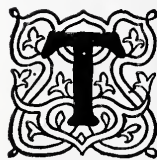

HERE are many old workers who ask the question, Will the stereoscope ever be revived again in America? And there are many regrets among intelligent people that it ever disappeared as it has. The reason has often been asked and many different answers have been given to the question. To my mind the principal reason was the carelessness often displayed in the printing and mounting of the views or stereographs, to say nothing of the fraud often displayed in deliberately mounting the views wrongly in order to cut prices and cheat the purchaser. Properly made there is nothing in the photographic line that gives more pleasure or satisfaction than really good stereoscopic pictures, and if these few hints will help some one to do really good work in that line, the writer will be amply repaid.

One reason we see so few really good views of this kind is the fact that almost anything makes a passable stereo picture, and the novice finding this out, does not take the trouble and care in composition and lighting that he would in ordinary work. To use a slang expression "Any old thing goes." Now this is not the way to turn out good work of any kind, much



J. ANTHONY BILL.

less stereoscopic work, and the writer cannot too forcibly say to those interested in this class of work, do the best you *possibly* can, study the effect of composition, light and shade, etc., and above all give long enough exposures to get detail in the shadows. The old maxim "expose for the shadows and let the high lights take care of themselves" is the golden rule to follow, and if carried out faithfully the operator will be not only pleased but greatly surprised at the result.

Owing to lack of time the pictures accompanying this article were not taken expressly for it and therefore cannot be considered the best, but they will give the reader a slight idea of what can be done and therefore will serve the purpose.

Probably the finest photographs in existence are stereoscopic positives on glass made with an extremely fine grain collodion process, or a very fine grain chloride or gelatino-bromide emulsion. And here let me emphasize that a really black tone is not only the most pleasing but suits the average view better than any other color. Extremely fine results, however, can be obtained for certain subjects in red or brown tones, and on glass views they can be produced by after toning, etc., the same as frequently done with lantern slides.

The writer would advise every worker to use a binocular camera wherever possible, as while a monocular camera may be used as a make-shift or for an experiment, the worker will never be able to produce the *best* results in that way, and, therefore, unless he is very persistent he is apt to get dissatisfied with the result and soon lose interest in the work. The question is often asked whether plates or films should be used for this work and also which gives the best results, and in reply to this I would say use glass plates wherever you can and study carefully the composition on the ground glass. Pick out views wherever possible that have a good foreground and if it cannot be had in any other way, throw some rough stones, boughs of trees, etc., to break up the foreground. A moderate opening of the lenses, say about F/16, will be found to give good results as a general rule, and it is best to have good sharp definition generally.

Don't take fuzzy types for stereoscopic work unless you wish to be disappointed, and above all be sure that the camera is level, whether it be held in the hand or set on the tripod.



Frederick Pohle.

The writer always carries a pocket level unless there is one on the camera.

Printing and mounting stereographs being so well described in the books and magazines but little remains to be said on that score. In printing from the negatives on glass, however, a simple transposing frame is necessary in order to slide the negative one way and the glass the other, but in making paper prints it is easier to make the two prints at once and before the halves are cut apart lay them face down, but right or correct vertically, that is, top should be at the top and foreground at bottom. While in this position mark the back lightly as they face you, the left with an L and the right with an R. On cutting apart the halves they cannot get mixed by this method, as the left goes face up on left end of mount and right at the right. It is an advantage to make a slight pencil mark exactly in center of the mounts before beginning to place the print.

If every one who takes up stereoscopic work will give it his best care and thought we would soon have a revival of the stereoscope, and now that small stereoscopes are made only about an inch thick and readily go in a person's coat pocket, there should soon be a great revival in that line. While on this subject I would say to any worker that if he wishes the best *possible* portraits of his friends try stereo. pictures of them, either in groups or singly, and a new pleasure and delight will be opened up to him.



EGYPTIAN LOTUS.

Illustrating article "Stereoscopic Photography," by H. W. Hales.

WHERE CAMERAS ARE NOT ALLOWED

By GEORGE STEELE SEYMOUR



THE familiar phrase, "No cameras allowed," may be called the watchword of cemeteries. All the larger ones display it prominently on signs near the entrance, while the smaller ones mean it even if they do not say it. But the enforcement of the oppressive decree is seldom left to more formidable policemen than the watchdog and the lame gardener, so what we may call graveyard photography presents many features of interest. Those who follow it as a pastime find in it a sport tintured with just enough of the flavor of forbidden fruit to make it enticing.

Statistics do not show exactly how prevalent is this practice among photographers of to-day. Perhaps regard for constituted authority should prompt a demand for its immediate suppression; instead, we who pursue it tell of our achievements much as the Supreme Court judge in "The Witching Hour" boasted of the painting which he had smuggled over in the top of his trunk. At any rate, it is too decidedly *sub-rosa* for mention in the British Formulary.

You stroll into a cemetery on a sunny day through the only entrance that is open to the public, your F P K in the pocket farthest from the little house where the watchman sits. If he is sunning himself before the door you may hand him a cigar, and pass a remark that will throw him completely off his guard. In this way you may even make him an unwitting accomplice and get a direction that will save you much fruitless travel. But the safest plan is to let him alone and take your chances of finding the grave you want. I did this, and spent the better part of a day tramping up hill and down dale in the great Forest Lawn Cemetery in Buffalo trying to locate the grave of Millard Fillmore, and finally came away pictureless but undetected. The plan has its drawbacks.

Photographing the graves of the Presidents is good practice.



BUFFALO BILL'S GRAVE,
LOOKOUT MOUNTAIN, COLORADO.

GEORGE STEELE SEYMOUR.

A few of them are known to every schoolboy—Washington at Mount Vernon, Lincoln's impressive column at Springfield and Grant's Tomb on Riverside Drive, New York. Garfield's tower in the cemetery at Cleveland is well known throughout the middle west. Jefferson rests under a plain shaft at his beloved Monticello, and Jackson is at home at the Hermitage, Nashville. Madison and Monroe are both buried at Richmond. Another town that harbors two Presidents is Quincy, Mass., where both the Adamses are laid away within a stone's throw of the two quaint old houses that were their birthplaces. New York State honors five within its bounds—Grant, Fillmore, Arthur in the Rural Cemetery at Albany, Van Buren in the old churchyard at Kinderhook and Roosevelt, the latest, at Oyster Bay. Cleveland is the only President interred in New Jersey, at Princeton. He was born at Caldwell in the same State, in a little cottage that I have often seen. McKinley rests under a Greek temple at his home, Canton, Ohio.

A visit to the grave of Franklin Pierce, the great son of New Hampshire, formed a side trip of one of my vacation rambles. Concord is justly proud of him. His statue stands in front of the State Capitol. A few yards further up the street is his law office with his shingle still hanging out on it. The same street leads us to the cemetery where he rests—a friendly place, marred by no menacing announcements. Here lie also the Rumford family, descendants of the great Benjamin Thompson who was ennobled by the Pope for making heat by the friction of two pieces of ice. We remove the gardener's coat so that we may read the inscription on one of the ancient stones. He bears us no ill will for it, but directs us to the Pierce lot and opines that the sun will be out shortly.

Some American cemeteries and their occupants are widely known. Such is the one at Arlington, opposite Washington, where Generals Sheridan and Crook and a host of Civil War heroes are buried. Such is the romantic Sleepy Hollow at Concord, Mass., where Hawthorne, Emerson, Thoreau and the Alcotts made their long stay. Such is Trinity churchyard in the lower portion of New York City, distinguished by the names of Fulton, Hamilton and many of the founders of the metropolis. In the upper reaches of Gotham is to be found another Trinity cemetery, the last resting place of John James



GRAVE OF WILLIAM H. SEWARD,
AUBURN, N. Y.

GEORGE STEELE SEYMOUR.

Audubon. This sward displays a most violent antipathy to cameras, but Audubon's monument can easily be photographed through the fence, and all the proprieties vindicated. Working northward, the grave of Joseph Rodman Drake is marked by a shaft grouped among half-a-dozen of its kind at Hunt's Point. While standing before this simple memorial we must inevitably recall the touching lines of Fitz-Greene Halleck, a memorial more splendid than those of many kings ;

"Green be the turf above thee,
Friend of my better days ;
None knew thee but to love thee,
None named thee but to praise."

But we must not leave the big city with all its mortuary treasures without a glance at a real historic beacon—the grave of Peter Stuyvesant under the wall of his own church, Saint Mark's in the Bouwerie. The stone is set low down in the outer wall and there is a hedge running close in front of it, so that it is in a position where it is almost impossible to photograph, but it would be quite an achievement to do so. While we are flying across the ocean and establishing all sorts of new records, will someone take a moment to do this stunt ?

Up the river at Tarrytown is another Sleepy Hollow—the original and famous one—and there within sight of the Old Dutch Church that he immortalized lies

"the gentle humorist who died
In the ripe Indian summer of his days."

Ah, Washington Irving, would you have us laugh or sigh as we stand by your grave ? We must do one or the other, for the heart is full. You are here in the midst of your glory. Around you are the memories of by-gone days, the sturdy people of whose deeds you wrote, the country you celebrated, the legends you created. The Headless Horseman rides on and on without ever leaving the hollow but a short distance from where you rest. Down Sunnyside Lane still stands your home, kept by reverent hands. In the village is the church where you were once a warden. Those streets often echoed to your footstep. To no one else might Stevenson's epitaph be more fittingly applied—

"Here he lies where he longed to be."



GRAVE OF FRANKLIN PIERCE,
CONCORD, N. H.

GEORGE STEELE SEYMOUR.

Another grave of pleasant memories is that of Cooper in Christ Churchyard, Cooperstown. It is the old-fashioned flat stone kind, raised from the ground only a foot or so, and beside him sleeps his wife and near at hand are relatives and friends. Cooper, too, is at home in his own land—

“Hard by, the storied lake, and all around,
His loved Otsego hills.”

Ghosts pervade the whole place—ghosts called into being by Cooper himself. Tom Hutter still lives at Muskrat Castle, Chingatchgook still visits Council Rock, and after dark it is said that the shadowy forms of Leatherstocking, the great scout, and Uncas, last of the Mohicans, linger side by side at their creator's grave. But we will not be able to get them in our picture.

While we are still in York State we may find profit in a visit to Auburn, not to see its ugly prison, but to trace the footsteps of one of America's really great statesmen, William H. Seward. In distant Oregon I saw his statue, on the pedestal of which is inscribed, “Let us make the treaty tonight”—words that added an empire to our dominions. And here in “fair Auburn” I searched out his grave among many in a well-filled city of the dead and took a picture of it. Seward's grave is the third from the near end of the row.

Another member of Lincoln's war cabinet lies in Oak Hill Cemetery, Washington, D. C. This is Stanton. Here he is in company with John Howard Payne, Mrs. Southworth the novelist and many interesting people, overlooking the rugged banks of a romantic stream. I came upon him quite by chance on a slippery winter's day and the sitting he gave me was most satisfactory but it did not convert me to enthusiasm for pedestrianism on an icy hillside. In the far-off southeast district of Washington City is the old Congressional Cemetery with the curious beehive gravestones of early lawmakers. Under the tree by its chapel, Clay and Calhoun lie side by side.

The East is full of great men's graves. I have said nothing of visits to Boston, where are to be found John Hancock, Paul Revere, Samuel Adams and others of their generation; Cambridge, where Longfellow, Holmes and Lowell lie; Whittier's grave on the slope overlooking Amesbury and the Merrimac;



ENTRANCE TO A VENETIAN PALACE.

Louis J. Steele.

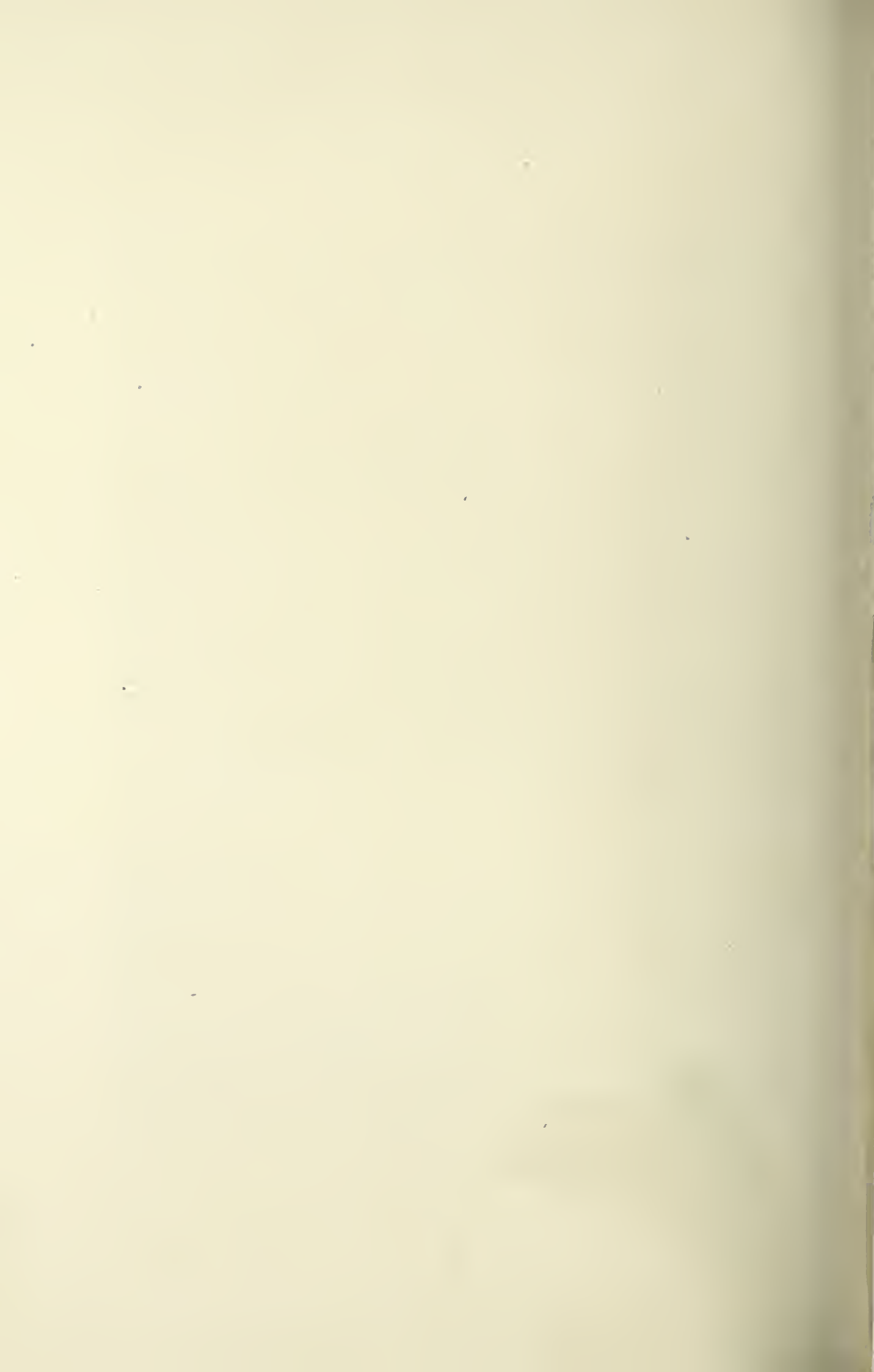

and the glimpse of Benjamin Franklin and Deborah his wife that one catches through the churchyard fence in Philadelphia. The West is more sparsely supplied, but to miss an opportunity in the West is hardest luck of all. One does not get to Taos, New Mexico, every year, and for your confirmed tomb-photographer to visit it and find out after departing that he has missed the grave of Kit Carson, is sad indeed.

In the little cemetery at Colorado Springs rest the remains of two Helens, wives of W. S. Jackson, and a space between them is reserved for their still-living spouse, now an old man. The outermost stone is inscribed, "Emigravit," denoting that she has removed from her original grave above Seven Falls which was chipped to pieces by souvenir hunters—far more dangerous fanatics than your gentle camera-smugglers. This is the final abode of Helen Hunt Jackson, one of America's most devoted writers.

But by far the most impressive spot that we shall visit is the grave of Buffalo Bill on Lookout Mountain near Denver. Up on the top of a rocky outpost of the great mountains that he loved so well sleeps the most intrepid scout that ever roamed the plain or rode the sawdust circle. Respected alike by the Indian whom he fought and the paleface whom he thrilled at two performances a day, the warrior rests at the end of the trail, as picturesque in death as he ever was in life. I well remember the flowing hair and queer frontier costume of him who wrote in the autograph book of a certain boy page in the Capitol building at Washington, "True to friend and foe." Here in the Colorado sun, so clear that pictures never fail, a shutter clicks on the last of him. It is good-bye to Buffalo Bill.

SIMPLIFYING AN EXPOSURE METER

By JOHN BOYD

HE use of exposure meters with sensitized paper to test the strength of the light is the only sure method of arriving at correct exposures. Yet how few there are who own one of these useful instruments who get to understand its capabilities. It is true the makers' instructions are clear and concise, but when it comes to actually working them out they are a bother, and the photographer is tempted to "guess" the exposure rather than fuss with the tables he has to figure out.

To eliminate this feature I have modified my Walkins Bee Meter in such a manner as to cut out all calculations whatever, either when working with or without a ray filter.

In the center of this meter the maker inserts his name, etc. I cut this out with a sharp knife, making an opening seven-eighths of an inch in diameter.

As I use plates and films which have a speed value of 180, I figured out what new speed numbers would be required to cover special subjects, such as clouds, snow or shipping scenes, or open views. These have a ratio of one-tenth, one-quarter or one-half of what is required for average scenes. My ray filter increases the exposure eight times, so in order to make the meter automatic in its calculations I had to abbreviate all the above matter in the small space at my disposal.

I, therefore, printed a small slip to fit the opening that had been cut out, using *black* ink for plate speeds for subjects without a filter, and *red* ink for those with the particular filter I use most frequently.

As the plate speed numbers only run up to 500, it was necessary to file two additional marks on the metal circle, one opposite the letter "L" in the word "plate," the other near the letter "E" in the same word.

The arrangement of the new center can be best explained by consulting the illustration (Figure 1) which shows the subject and the plate speed numbers for all plates in class 180.



THE SISTERS.

MAY L. SMITH.

The letters or figures in *black* ink are "E" for sky or sea views; "L" for shipping or snow scenes; "350" for open landscapes, and "180" for ordinary subjects.

The corresponding numbers in *red* ink for ray filter exposures are "180" for sky or sea views; "90" for shipping or snow scenes; "45" for landscapes, and "22" for ordinary subjects.

This arrangement does not impair the usefulness of the meter for calculating exposures on other plates or filters, but



Figure 1.

is a big improvement when one is using the same speed of plates or films from day to day, since all you have to do is to move the dial to the number or letter indicated, instead of trying to figure out an exposure by mental arithmetic. For instance you are taking a snow scene with a filter, with say light 11 and stop F/7. As snow scenes only take one-fourth the time of an average view, and the filter increases the exposure eight times it becomes a problem like this: One-twenty-second divided by one-quarter multiplied by eight, or one-eleventh second exposure.

With the scheme I have worked out, it simply means to move the dial until F/7 is opposite "90" (the ratio computed for snow scenes) and the time is instantly shown.



THE SUGAR-PLUM TREE.

J. B. ALLISON.

Illustration for the Verse by Eugene Field.

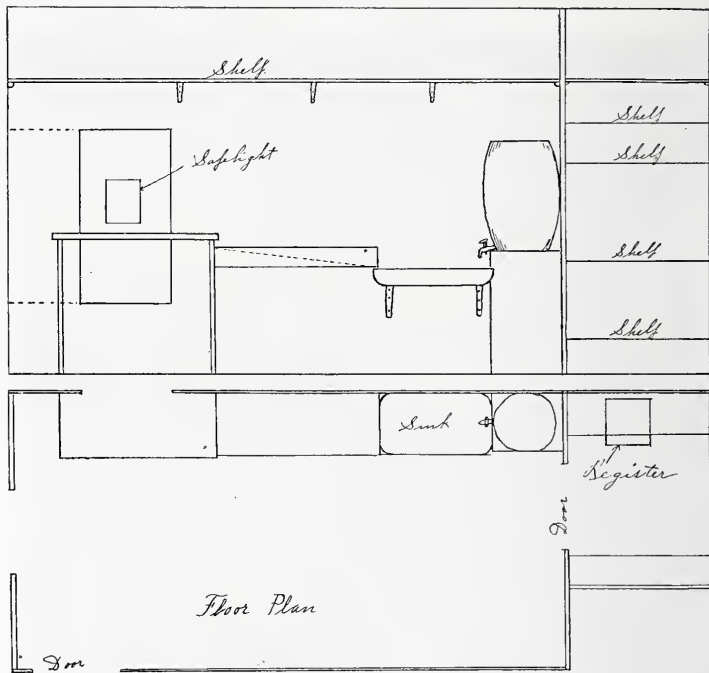

Figure 1

Illustrating article "An Amateur's Work-room," by Carl A. Peterson.

AN AMATEUR'S WORK-ROOM

By CARL A. PETERSON

IN the following sketches and descriptions of my room I have not tried to give any dimensions, as every one must try to fit things to his need and equipment. I only want to show how one could arrange things where there is no running water, or good artificial light to work with. As you will see by the drawing (Figure 1) of the floor plan and side-wall, I have one window on this wall which is closed with a sliding shutter. In this shutter there is a hinged frame which carries a safe light. This frame should be hinged at the top. By

changing the safe light to a ground glass a retouching stand is at hand.

The water is supplied by taking a small barrel, or keg, inserting a faucet and placing it on a stand over the sink. The drain pipe can be run straight out through the wall with a $\frac{3}{4}$ -in. pipe run down to the ground.

At the other end of the sink I have a table the top of which

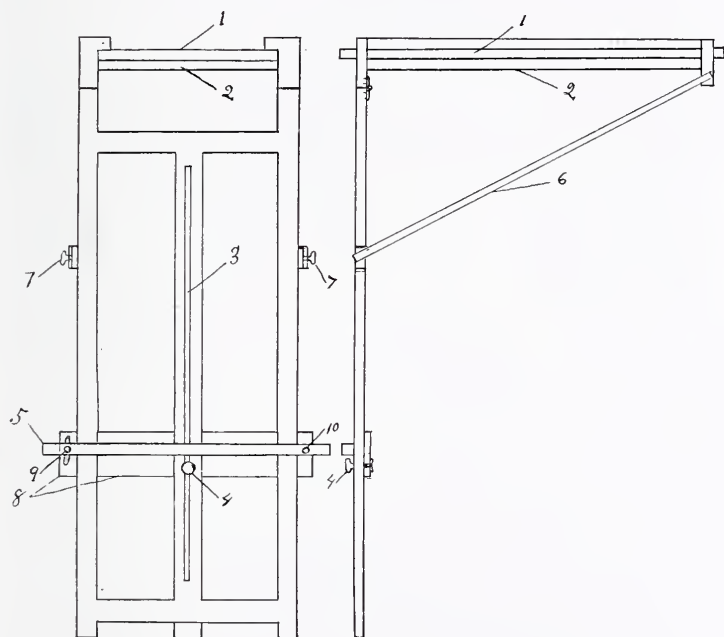

Figure 2.

is made of $\frac{1}{2}$ -inch strips nailed on cross bars but left about $\frac{3}{8}$ -inch apart. Under this open table there is a drain board, one end resting on the sink so when any water or solution is spilled it will drain into the sink. In front of the window is the work table. A shelf is run the whole length of the wall just high enough to be out of the way but easily reached.

Now for the other window which is the best part of my

room—see Figure 3. This shutter, which is used in printing and enlarging (5), shows a box or frame built so that I can attach camera to it in a minute. In this box is an opening where a slide which carries negatives to be enlarged are

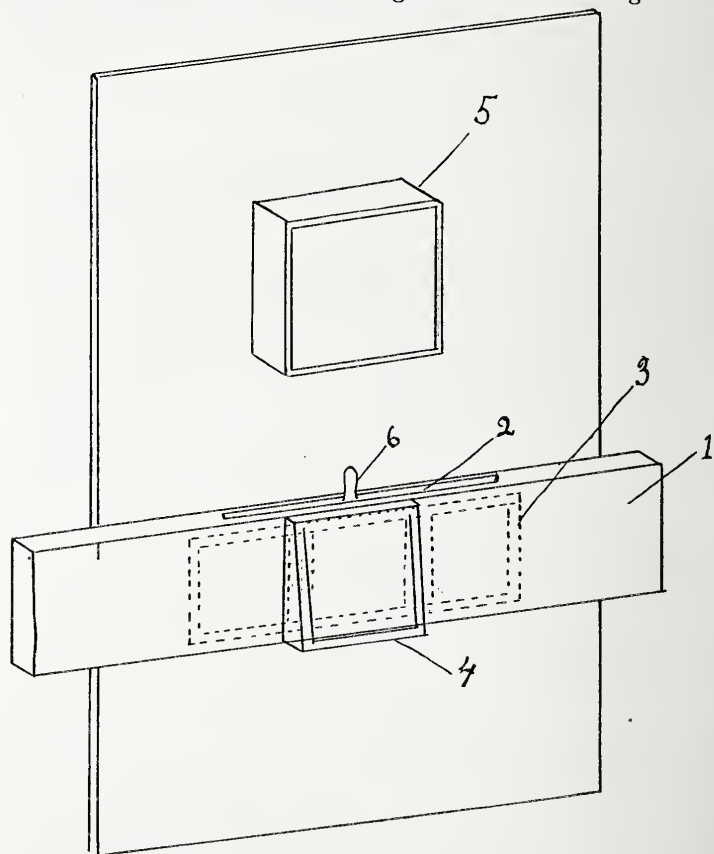

Figure 3.

inserted, also a dark slide to keep out the light when not wanted. The enlargement is thrown upon a sliding easel which is hung from a track suspended from the ceiling, and can be raised up so it is out of the way when not in use. Figure 2 will give an idea of the easel: (1) is the track which may be a



THE SOUL OF THE OAK.

Louis A. Goetz.

board 1 x 10 inches as long as you want the track to be; (2) is a short board the same width as the track and serves as a slide to hang the easel from; (3) is a slot cut out of the center part of the easel through which a set screw (4) slides and holds the shelf (5) wherever it is wanted; (10) a bolt which passes through the shelf and holds it to the back board (11). This board is grooved so it slides on the three uprights of the easel; (9) is a set screw working in a short slot cut in the back board. This is to tilt your enlargement in case the subject is not straight on the negative, (6) two braces clamped by set screws (7).

A drawing board or printing frame is used to hold the paper when enlarging.

Figure 3 shows a plan of window shutter, (5) shows position of enlarger on which my view-camera can be attached, (1) shows arrangement for printing. It is a very simple arrangement consisting only of a light-tight box just deep enough to enclose the sliding shutter (3). This shutter should be about three and one-half times as long as the largest negative to be used. By making it with three openings a safe light can be put in the two end openings and a ground glass in the center. It is operated by the handle (6) which works through a slot in the top of the box; (4) is a box built on to hold printing frame. It slants in at the top a little so the frame will not fall out. It should be just large enough to hold the largest frame used.

The frame is supported in a rabbet without any kind of fastening, which makes it quick to handle. The center opening in the slide ought to be at least one inch larger than negative or opening in printing frame. I find it works out very well to have whole window glazed with ground glass.

As I have a small closet at the end of my room I fitted it with shelves for storing and also one wide shelf where I do such work as loading plate-holders, etc.

In the floor in this closet a hole was cut and a register fitted where the warm air from below can come up when wanted in winter time. Now to finish; everything was given two coats of good white paint, as the lighter color used the less light needed to work by, and so much easier to keep clean. Keep everything off the floor if possible.

MODERN PORTRAITURE

By AUGUST KRUG

IT is hoped that these few random notes on the condition and trend of modern photographic portraiture will serve to guide to fuller accomplishment some of my fellow workers in the most fascinating of hobbies. There may be statements here with which you do not agree; accord them the courtesy of careful consideration before passing judgment. To err is human: the writer also is human, although a diligent student of portraiture.

It will hardly be disputed that the influence of the amateur (using the word in its largest sense, one who works for the love of the work) has been the means of placing photographic portraiture on its present footing. The number of so-called "advanced amateurs" who have entered the professional field—graduated as it were—is very great. The conditions under which they work and their unwillingness to conform to cut-and-dried methods of procedure are responsible for the wave of unconventional portraits which has engulfed us. The old order changeth—wh ois there to say that the change is not for the better?

The conventional studio light coming from a little in front and at an angle of forty-five degrees, so much desired by ambitious amateurs in the past and even now, I dare say, has given way to the idea that any light which will give you what you want is the light you want. There are no restrictions placed upon the light to be used, no rules to be followed: portraiture becomes correspondingly more difficult. It requires infinitely more ability to obtain good results with unconventional lights than with the studio lighting. With the latter, there is one position for the sitter, one place for the camera, and the light must be screened just so. Let several people be photographed in this way and the photo prints will be



AUGUST KRUG.

identical, except for a slight change in physiognomical contour.

But the artist who works "as is" will arrange a light which enhances the good points of the sitter, and covers up the defects as well: he does not attempt to make the sitter's features conform to one of a few accepted styles of light. Nor does he hesitate to under-expose if the exigencies of the situation seem to demand it; he obtains a result in which the characteristics of the sitter are predominant. In a word, the present day portraitist is imbued with an idea. It is to make his portraits actual representations of his model as they *are*, and not as he thinks they should be. This is the shortest way to express the collection of axioms about "character," "expression," "naturalness," and the rest.

That the end justifies the means has now practically universal acceptance by photographers and others interested. Oddly enough, now that retouching is permitted, very few use it to the extent once thought desirable. The removal of obvious defects such as warts, freckles, and so forth, is its only application nowadays. Such tours-de-force as the removal of double chins, chair backs, and two-facedness on account of "moves," are never required. The skillful portraitist takes care that they are not needed. He knows that no hand-work can take the place of the delicate tonality obtained by the action of light, or even approximate it. Technical finish is always to be desired. Still, a good deal may be excused in a portrait provided it accurately represents its subject. The perfect print may be made from a decidedly imperfect negative.

One point has not been touched upon—the question of diffusion need give us little concern. The same principles of liberality which apply to lighting also govern this subject. As in lighting, it is well to remember that extreme will give bizarre and striking effects often, but good likenesses seldom. The hard microscopic definition of the anastigmat will be avoided by everyone with sensibilities: the danger lies at the other extreme. The art director of one of the highest class New York magazines referred humorously to some of his contemporaries, saying that they believed that every photograph which was not sharp was artistic; this may seem far-fetched, but it is a tendency of the photographer to regard it as the truth, es-



A JUNE MORNING.

C. E. WAKEFORD.

pecially, (dare I write it?) when the unsharp picture is his own production.

To summarize the present day portrait photographer: he arranges and lights his subject in a characteristic manner, remembering that anything which can be seen can be photographed; adjusts his exposure properly to render the tones for which he is working, and develops just as carefully to suit his exposure; he prints in such a manner as to retain on paper the quality secured in the negative. Go thou and do likewise!



CINDERELLA.

KATE MATTHEWS.



Copyright by A. L. HITCHIN.

TAKEN FROM AN AEROPLANE.



Illustrating article "Nature Photography," by Arthur H. Farrow.

NATURE PHOTOGRAPHY

By ARTHUR H. FARROW

ONE of the most pleasing and gratifying products of modern photography is the growing tendency among amateur photographers to take up the study of Nature work by means of the camera. Not so very long ago, Nature photography was principally practised by a few specialists, and the impression prevailed that more than ordinary skill and elaborate and expensive apparatus were required for the work. It is very interesting to observe that each season a steadily increasing number of workers are devoting attention to hunting the denizens of the countryside with the camera instead of the gun—and are taking a wider interest in the portraying of all Nature subjects. It is a form of camera work that soon becomes very fascinating and has an abiding interest for its devotees.



JANE REECE.

The love of Nature is instinctive in most of us, although it is true that in many people it lies latent, but when we learn to approach Nature, seeking for beauty and to find some of her hidden mysteries, we are amazed at the reward she spreads before us. Familiar things take on new beauties and we wonder that our eyes have been so long closed to them. To many the camera has been the companion that has led them out, and little by little awakened an appreciation of the beauties of Nature.



Illustration.

If we were to attempt to enumerate one tithe of the many subjects available to Nature photographers, these notes would swell out of all proportion to the space allotted to them. We can do very little except to try and create an interest in this enjoyable work. Once that interest is acquired, the worker will find no lack of subjects. The field is such a vast one that we are inclined to think that it is better for one to specialize rather than tackle the subject as a whole. For those to whom the birds appeal, more than ample material will be found to occupy

one's whole attention in them alone ; those who love the wild flowers will find that each succeeding month brings new subjects.

Nature photography has two outstanding features that should appeal to all—it is health-giving because it takes one out into the open air ; it is educative because it opens the eyes to the wonders and beauties of Nature. The great amount of information that will be unconsciously assimilated regarding



Illustration.

the ways of Nature should prove ample recompense for the attention devoted to it. Out in the country one feels the charm of the open air stealing into the consciousness and filling the veins with a fresher life. The roar of the great city is far away ; its unending stress and overpowering absorptions have for a time faded from memory. Frequent trips into the country will make one forget business and other worries and will act as a tonic for tired and overworked minds and bodies.

Not alone does Nature photography lend itself to the making of records, it presents unlimited possibilities for artistic studies. It should especially appeal to the worker who is looking for new fields in which to exercise his skill.

If one gains an interest in Nature work with the camera, one is sure also to gain an interest in the subjects that are portrayed. Steps should be taken to familiarize ourselves with the names, habits and characteristics of the more common wild flowers, birds, butterflies, moths, etc., so that we will not only know them by sight, but by name, and where to look for them. Interest is the key to the door of knowledge, and the study of Nature will open up a new world of fascinating and abiding interest.

If there are any amateur photographers who have not attempted this branch of the art because of the idea that special and expensive apparatus was needed, we will put their minds at rest by saying that for a start, at least, no special apparatus is necessary. Much very satisfactory work has been done with just an ordinary camera and inexpensive lens. The camera that is used for general outdoor work is all that is really required. If it is one of the Kodak type, a metal tripod, or one of the new Kodapods, and a portrait attachment will prove great helps. If it is a plate camera, one with ample bellows extension is to be preferred, as there will be plenty of close-up work. While not absolutely necessary, a camera of the Graflex type makes an ideal instrument for a great many subjects that will present themselves. Of course, as in other fields of photographic work, the better camera and high-grade lens will make available subjects that would otherwise not be possible.

Color sensitive plates and color screens will be found essential for subjects like brilliantly-colored wild flowers, butterflies, etc., for instance. It should hardly be necessary to point out that greater success will be achieved by becoming familiar with the possibilities and limitations of one's camera. A great many failures and disappointments come from attempting something which a particular type of camera is not intended for. It is getting to be generally understood that there are many branches of Nature photography that can be successfully undertaken by the novice, with quite an inexpensive outfit, providing the wonders of Nature appeal to him, and he is blessed with a



GILL & SON.

certain amount of patience and perseverance.

For the worker who is interested in stereoscopic photography, Nature work with the camera opens up a field for which it is peculiarly adapted. The old adage that "seeing is believing" applies in a special way to Nature subjects made with a stereo camera, and the resultant pictures are bound to awaken enthusiasm in all who view them.

A collection of Nature pictures in a portfolio or album will always demand much attention and admiration, but we think the best method of exhibiting one's pictures is by means of the stereopticon. Every amateur photographer should make lantern slides, and a stereopticon should be included in every amateur photographer's outfit. Lantern slide making is one of the most absorbing branches of the photographic art, and at the same time, one of the easiest of photographic processes. Few things will prove more enjoyable than being able to exhibit one's Nature pictures, brilliantly illuminated on the screen, by means of true-to-Nature colored lantern slides. Once the negative is secured, the making of lantern slides will be found to be just as easy as making prints, and the coloring should present very little difficulty after the first few attempts

*"If you would find true happiness
Seek for it not in gilded halls
Amid the scenes of worldliness,
Go, rather where the wild bird calls
You, down along the forest aisles
Where Nature on you kindly smiles."*

AMOS K. MEHL.



A. N. DREYER.



F. SALAZAR.

POSSIBILITIES OF TELEPHOTOGRAPHY

By FREDERIC FELIX



SOMETHING has retarded the general adoption of the telephoto lens in the equipment of those who strive to be prepared for every condition in picture making. Many are to be found with every other variety of apparatus and aids for photographic work, but the lens combination that overcomes distances and difficulties of inaccessibility is, singularly, omitted.

Inquiry at some of the stock houses meets with replies indicating they are out of touch with the specialty and give it no thought. One manager, in saying he hadn't any information to offer on the subject, remarked, frankly: "It was a fad and has died out. Combination lenses will do as well."

At one of the photographic clubs a group discussed telephotography in much the same manner—as a diversion taken



THOSE EYES.

G. W. Harting.

up, some time ago, for the novelty, but set aside for lack of practical application.

One of the speakers said: "It is a lazy man's method—staying in one place and photographing everything around him, at all distances. It hardly justifies an ordinary amateur to keep up an equipment, especially when the good results with a combination lens are considered. An objection is the length of exposure. A heavy, rigid tripod and camera are necessary for extra magnification exposures, and the distance traversed and the increased length of time required bring an effect of atmosphere which is detrimental, unless the air happens to be exceptionally clear.

"A modern anastigmat lens combination will prove ten to fifty times as rapid as a telephoto lens. Its pictures can be enlarged four to eight times and it will then prove more convenient and give better results. If one uses 5 x 7 fast plates, an eight-inch anastigmat lens, stops it down and gives a tenth of a second exposure, a picture will result, which, if enlarged four or more times with the same lens, will give all that is desired and also have the appearance of a contact print."

Plainly there could be few conversions to telephotography under such influences. Some other source of information had to be sought. An enthusiastic contrast came upon applying to Dwight L. Elmendorf, the noted travel-talk authority. He can present the attractions of telephotography so convincingly that all other points of view apparently vanish, and his statements, and the spirit of them, seem ready for complete adoption.

Mr. Elmendorf has not lost a degree of the enthusiasm that caused him to be an inventor of the modern telephoto lens in all these years since he felt the need of one first, without being able to go out and find one in the photographic market.

Photographing the wonders of the world, to put them into stereopticon screen talks, would be much restricted, in many instances, unless the equipment included a combination that could bring distant mountains forward, cross chasms and streams for the views beyond, record the life of untamed animals in their wild surroundings, select an architectural detail positively inaccessible, and do other things that had been difficult. Mr. Elmendorf acquired his first incentive in the application of telephotography to the regular camera when he

was a student at Princeton University, and assisted Prof. Young in photographing the transit of Venus. A thought struck him—if possible to photograph things celestial why not things terrestrial in the same method. In 1886, some time after being graduated from Princeton, he bought a three-inch Darlot telescope, mounted it on a tripod and connected it with a camera affixed to another tripod. From the roof of his present residence and laboratory, on Sixty-eighth street, New York City, he focused his combination upon the men engaged in gilding the dome of the New York World Building, five miles



The Organ—Jupiter Terrace, Mammoth Hot Springs, Yellowstone National Park. Taken by Dwight L. Elmendorf, with an ordinary camera in 1889.

distant, and made a photograph, with good results. As far as known this is the first picture of the kind ever made. The outfit gave the equivalent of a lens of 160-inch focus.

Mr. Elmendorf thus proved telephotography a possibility, but its difficulty of application, under such conditions, was apparent. There was need for something more serviceable, and he began work upon simplification. Out of the wreck of his studio in New Jersey, where flames destroyed a wonderful collection of 14 x 17 wet plate negatives, made all over the United States, and all his other equipment, he brought with him to New York a partly destroyed field glass. One side was

gone and it had been hung up as a relic of the old days, undisturbed until the experiments to find a substitute for the cumbersome telescope. The burned portion was then cut away and the single barrel was left in its original optical efficiency. By means of a piece of card-board, with a hole in it, the glass was put in the regular camera and, to Mr. Elmendorf's great delight and surprise, gave a beautiful image on the ground-glass. When it came to making negatives there was disappointment. The image could not be made sharp, owing, partly, to the vibration, and partly because the combination was not corrected.



Detail of "The Organ," included in the limits of the dotted square upon the full view. The huge rock formation is inaccessible because of boiling water flowing in front of it.

But these were things that, plainly, could be adjusted, and the operator had the great satisfaction of realizing a combination eight inches in length was to give him an image almost as large as his unwieldy telescope arrangement. He had but to proceed with the adjustments for the success that finally came. It was a reduction in measurements only that was required, the principle remaining the same—a convex lens in front and a concave behind. The perfected outfits that may be purchased to-day are the same.

He had been using a 4 x 5 six-inch focus rapid rectilinear lens for his general work and he decided to fit an achromatic nega-

tive lens to it. He did his own grinding in converting an old lens and produced an achromatic of one-inch focus. The combination was too powerful—the magnification was so great that sharp images were impossible. Mr. Elmendorf went to London in 1888 or 1889 and called on the Dallmeyer house, with his experiments, to get them to make him an accurate negative lens. He was surprised to find they had been experimenting at the same time he was at work, and that they were preparing to put a telephoto lens in their new catalogue. They were using a portrait instead of a landscape lens as an objective and a high power negative, or concave, lens behind it.

Mr. Elmendorf took one of the new combinations and, at Black Friars' Bridge, made a photograph of the dome of St. Paul's Cathedral, repeating the view also with a regular 4 x 5 outfit. The house had not been successful in its pictures that far, but results were perfect in this instance and arrangements were at once made to include the new views in the catalogue as the first illustrations of what a telephoto lens could do.

It was a clumsy arrangement, but Mr. Elmendorf bought one of the first made and intended using it if his own experiments did not develop as he desired them to materialize. He left an order for a negative lens, similar to his experimental one, to have a three-inch focus, or about half that of the Dallmeyer combination. When the lens was delivered to him and put into his 4 x 5 outfit the results were perfection and he has been using nothing else since then for those especial needs. The attachment is a tube $5\frac{1}{4}$ inches long and $1\frac{1}{2}$ inches in diameter, with a rack and pinion on the tube, which he attaches to his old-time rapid rectilinear lens outfit.

Mr. Elmendorf works only with lantern slides and confines himself to the use of a 4 x 5 view camera, made forty years ago, to his order, by the E. & H. T. Anthony house. It has a bellows extension of twenty-eight inches, which produces a thirty-six time magnification with the telephoto lens. When the extension is not more than that of an ordinary 4 x 5 bellows, or if used on a camera of the regular market, the lens gives a magnification of six diameters.

In his world-wide travels he finds the one 4 x 5 outfit responsive to all requirements of tripod view work and instantaneous hand use. The tripod is kept attached all the time,



EUCALYPTUS TREES.

FEDORA E. D. BROWN.

even when the camera is used in the hands. The lower tripod extensions are folded, and the shortened stand acts as a steadying and leveling pendulum when the camera is raised in the hands and the exposure made by the aid of direct view finder.

He follows and recommends the use of one camera, with six or eight lenses to meet the demands of varied exposures. In his lens outfit are a $9\frac{1}{4}$ -inch Protar, a $6\frac{1}{2}$ -inch Protar and a Series IV Zeiss 4-inch. The Zeiss lens is used for wide angles, but never if longer focus can possibly be used. He follows the rule that true, undistorted perspective cannot be assured unless



*View of the Muenster—or chief church—in Basle, Switzerland,
Taken by Dwight L. Elmendorf, with an ordinary lens.*

the focus of the lens is twice the diagonal of the plate. The telephoto outfit that adds to the equipment is equal to lenses of from fourteen to eighty-six inch focus. He does all his own work, using ordinary Metol-Hydrochinon developer and a special tank, of large capacity. His lantern slides, enlargements, motion pictures and all varieties of work are his personal product complete. His laboratory is a modernly equipped factory, with electrically driven lathes, drills, grinders and other installation by which he is able to convert, adjust, repair and construct all his needed lens and camera apparatus.

Mr. Elmendorf firmly asserts that the telephoto lens is not only just as useful now as ever, but even more so. In many instances there is need for a little more exposure than under ordinary conditions, but the speed of combinations has been so increased that instantaneous exposures are possible in good light. Taking successful moving pictures with the telephoto combination is good proof of the attained speed. Vistas are never entirely satisfactory if taken with a lens of ordinary focus—they flatten out—but a telephoto lens brings ideal results of perspective.

Mountains, architectural studies out of ordinary reach, wild animals in their homes, and other difficult needs, and some forms of portraiture, respond fully to the use of a telephoto lens. Mr. Elmendorf suggests a folding bellows camera, 4 x 5 inches or up, with a six-inch extension to give added depth of focus, and a Telar lens, which will give a magnification of two to four times that of an ordinary lens, with a rapidity sufficient to permit hand exposures to be made. A fortunately selected lens outfit and the proper interest and enthusiasm upon the part of the operator will bring pleasure and satisfaction.



Detail of the church, taken with a telephoto lens from the same point of exposure. The limits of this picture are inclosed by a dotted square upon the full view.



ECLIPSE. MOON COVERING THREE-QUARTERS OF SUN.

Illustrating article "Photographing the Eclipse," by Carl Krebs.

PHOTOGRAPHING THE ECLIPSE

By CARL KREBS

THE Astronomers had foretold an eclipse to occur June 8, 1918. Scanning the columns of the daily paper, I came across several paragraphs giving an account of the approaching event. During the perusal, the thought came into my mind, "How much of a photographic record of this phenomena could be made by the available means of the average amateur?"

Studying the subject by referring to prints, made on former occasions in which the picture of the sun appeared, the following points presented themselves for consideration: "the size of the orb of day in the picture to show distinctly what was going on in the heavens; and getting away from the intense halation caused by shooting directly into the sun".



ALONG THE BRANDYWINE.

George Steele Seymour.

The double combination rectilinear lens with which the picture "Sunset on the Coast of Lake Erie" was taken proved itself entirely inadequate. It was, therefore, advisable to use the single part of the same lens or a telephoto lens, which would increase the size of the picture three or four times. The former question would be effectively met by using a double-coated orthonon plate and a yellow screen of the density to cause an exposure from six to eight times as long as would be necessary without the same. These were the principal points, which required a bit of special study; the rest was a matter of regular dark-room methods and my own fancy in finishing the prints. And now for my story of the venture.

Having been fortunate enough to slip away from my daily tasks an hour before the eclipse took place, I picked up my tripod and camera and a sufficient number of loaded plate holders. Just before leaving home a thought occurred to me to slip the orange glass out of my dark-room lantern and into my pocket. This would be even better to view the sun through than the customary smoked glass.

The locality chosen to take my picture was the Valley of the Big Creek. This valley is situated south of the big city, and, as the prevailing winds here are from the southwest, the atmosphere is usually clear from dust and smoke. The day was perfect for the observation of the eclipse. Arriving at the creek a half hour before the shadow of the moon would touch the disc of the sun, there was ample time for preparations. The picture, as intended, should include a road or path, or the course of the creek, so as to enhance the interest to the casual observer, but as the sun at this time of the year (June) still was high in the sky during the occurrence of the eclipse, this was impossible. However, a solution of this problem soon presented itself. An isolated wash-bank, called by the old settlers "Rattlesnake Hill", loomed up directly in front of me. By focusing the top of this hill, whose contours were broken by several old trees, on my ground glass, the sun dropped right into its proper place in the picture.

The latitude in which I was working was that of the southern coast of Lake Erie, and the eclipse here was only partially visible. When at its greatest height, three-quarters of the moon passing before the sun, I exposed a plate, stopping the

diaphragm down to U. S. 16 in order to avoid possible errors in focusing. Wishing to obtain merely a record, and not a history of the eclipse, one plate was all I desired of the event. However, to forestall any loss of this plate, I proceeded to take a second one. Changing my position in order to procure a different outline of the hill, I re-focused and observed a peculiar distortion in the circular disk of the sun. "Was the lens playing a trick on me"? Changing the focus did not alter the mystifying aspect of the sun. I examined the lens, thinking it had loosened in its threads, but found it perfectly in place. I then resorted to my orange glass and ascertained that the lens was not telling an optical lie, the distortion was there to the naked eye as well.

An explanation of this seeming distortion may be looked for elsewhere, as this essay treats only of the photography of the eclipse. Discovering this phase, a plate was quickly inserted into the camera, and another exposure made. Packing up my kit, I wandered home, looking forward with great expectancy to the results of my expedition. Should it prove successful, I would have a new subject to add to my pictorial diary of the year. May the reader judge for himself by the accompanying illustrations!



LAST QUARTER OF ECLIPSE, SHOWING DISTORTED FIGURE OF SUN.

Illustrating article "Photographing the Eclipse," by Carl Krebs.



SUNSET ON THE COAST OF LAKE ERIE.

Illustrating article "Photographing the Eclipse," by Carl Krebs.

PINHOLE PHOTOGRAPHY

By MARK W. STEVENS



SINCE taking up "pinhole" photography some years ago and really getting acquainted with it I am quite surprised to find the many advanced workers who know nothing of the use of this fascinating method of picture making, or else, if they do know of it, regard it merely as a freak way of making a picture, and not a really serious method of attaining certain definite results with the camera. It occupies a place all its own in artistic photography for its work is like nothing else. It will give all the softness of a soft-focus lens at full aperture, and yet will give equally soft definition in the closest foreground and in the farthest distance. A small hole will give almost the definition of an R. R. lens, and yet retain a brilliancy of image and a subtle softness of outline that is entirely charming.

To the advanced pictorial worker it offers a means of obtaining wonderful rendering of sunlight and shadow, particularly in the woods, where one encounters large masses of shadow and half-tone picked out with brilliant spots of sunlight; a view that attracts and holds the eye and is, at the same time, the despair of the worker who is trying to interpret his impression of it with a lens. The results with a pinhole will be much more satisfying for the spottiness of the view, as a lens would reproduce it with hard, sharp outlines of light and shade, while the pinhole would give a soft blending of light into shade that would make the print look as the eye saw.

The professional is overlooking a good method, it would seem to me, in not using the pinhole for some of his work that is to be reproduced for advertising. Witness the very attractive ads of the Oneida Community in presenting their "Community Plate." Also, one of the large automobile factories in Detroit is planning to use the greater part of their advertising



KNAFFL & BRAKEBILL.

appropriation this year for soft-focus prints of their product. And this money will go to an amateur because most of the professionals do not use soft-focus lenses. The pinhole would do the work as well as the soft-focus lens. Many a fine residence also would make a more attractive view if made with a pinhole instead of with a lens.

Some workers have tried to use the pinhole and found the matter of exposure a stumbling block as there was, up to a few



Figure 1.

years ago, no definite formula by which one could calculate quickly and accurately the necessary exposure under any and all conditions of light, subject, and pinhole. Dr. H. D'Arcy Powers, an ardent and scientific experimenter, finally discovered a definite relation between the lens and pinhole, and from this he evolved a formula by which pinhole exposures can be calculated with all the accuracy of lens exposures. He has adopted a series of holes of definite sizes which are num-



WHERE LILLIES GROW.

WM. LUDLUM.

bered 1, 2, 3, 4, and 5. The hole number is multiplied by the camera extension in inches and the results used as an F/-number except that the exposure is read from the meter as minutes or fractions of minutes instead of seconds or fractions thereof, and as hours instead of minutes, should the exposure run to such lengths.

The matter of making a pinhole equipment offers no serious difficulty to anyone accustomed to the handling of small tools. My own practice, and I have made several of these outfits for friends, is illustrated in the sketches (Figures 1 and 2). Two pieces of 16 gauge brass, "A," 1½ in. in diameter are drilled with six concentric and equidistant holes ⅛ in. in diameter,

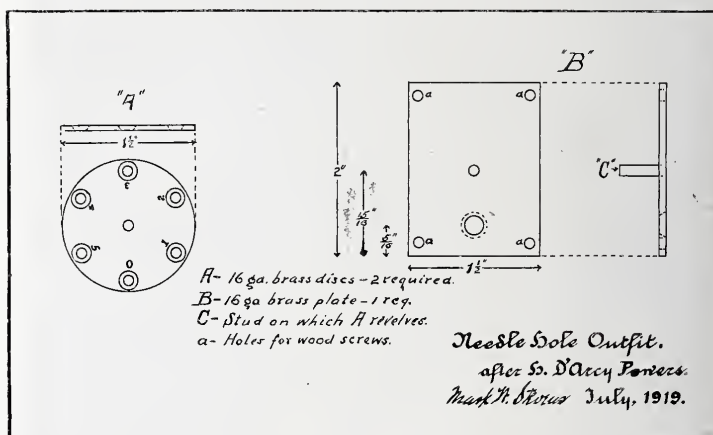

Figure 2.

carefully countersunk and with another hole in the center on which the discs are to revolve. Some brass or copper as thin as possible, 1/200 in. thick is preferable, is obtained and a strip is cut two or three inches long and about a quarter of an inch in width. Through this thin metal are carefully made the five holes, which are to be one millimeter, (1.0); three-quarters of a millimeter, (0.75); one-half millimeter, (0.50); three-eighths of a millimeter, (0.375); and one-quarter of a millimeter, (0.25) in diameter.

The best way to get these sizes accurate, and this is necessary, is to beg, or borrow, a micrometer caliper graduated in the metric system and then take friend wife's needle book and



THROUGH OCTOBER MIST

L. D. Sweet.

measure up the different sizes until five needles are found which correspond to the sizes given. I found the five I wanted in a very short time. The holes in the thin metal are made by laying the strip of metal on a blotter, which in turn is laid on a discarded negative or similar piece of glass.

The largest needle (No. 1) is then pushed through as far as it will go, withdrawn, and the metal turned over and laid on the glass. A small burr or protrusion will be noticed, and this must be removed by lightly rubbing with a piece of very fine emery paper glued to a light stick. The metal is then turned face up again and the needle pushed a little farther through and the burr again removed. This process is repeated until the needle will pass through its entire length, except the eye part, which is usually somewhat larger than the body of the needle. Care must be taken that the needle is at all times at right angles to the metal being perforated. The two pieces "A" are now held tightly together by a small machine screw and nut through the center hole. One of the small pieces containing a needle-hole is now slipped in between the two discs and the needle-hole centered with the countersunk $\frac{1}{8}$ -in. hole, and a drop of solder applied to the edge to hold it in place. This operation is repeated with each of the other four holes. The sixth hole, for which there was no thin metal with a needle through, is used for composing the picture on the ground glass. The piece "B" is now made of 16-gauge brass. The central hole is countersunk on the back side of the plate, the four holes in the corners drilled and countersunk to fit small brass wood screws to hold the outfit to the lens board and a threaded stud fastened in at "C" on which the discs are to revolve.

Before making the final assembly the parts must be boiled for ten or fifteen minutes in a strong solution of lye to remove all grease and dirt adhering to them. When the boiling is finished the lye solution is poured off and the pieces thoroughly rinsed in running water. The pieces must not be touched with the fingers after this boiling as the fingers are always greasy, and any grease on the parts would cause trouble in the subsequent blackening operation. A solution is now made up of water, 1 pt.; hypo, 4 oz., and alum, 1 oz. When thoroughly dissolved this solution is poured over the brass and the whole

brought to about boiling point. In the course of five or ten minutes the pieces will have become a rich, matt black. Pour off the solution, rinse thoroughly in water, and allow to dry spontaneously.

The parts are now to be assembled and the whole mounted on a lens board for attachment to the camera.

For purposes of illustration we will suppose that we have finished our outfit and are out in the field with it. We have set up our camera before a roadside scene, with no strong shadows in the foreground. Inspection of the ground glass shows that we need 11 in. extension of the bellows to get just the right amount on the plate. We decide to use hole No. 1. The exposure should be what? Hole number (1) times camera extension (11) equals what we may call $F/11$. The meter, under bright summer sun, and using Standard Orthonon plates, calls for an exposure of $1/25$ of a second for this class of subject, at $F/11$. We proceed to make an exposure with our pinhole of $1/25$ of a minute, or $2\frac{1}{2}$ seconds. It might be just as well to give a full three seconds as this would be easier to time and it is always safer to give rather more than the meter exposure in all cases. (I find this to be true with the lens as well as with the pinhole.) On development the plate will be found to be properly exposed, giving good detail in the shadows, etc., if the size of the needle-hole is correct.

It is very hard to present such a subject properly in so brief an article as this. I have endeavored to touch briefly on the salient points of the matter, enough so, I trust that one may take up this most attractive branch of photography with reasonable hopes of success. To anyone, however, who wishes more detailed information on the subject, I can do no better than to advise the careful reading of "Photo-Miniature No. 70" by Doctor Powers. I hope others will get busy. I am sure that they will like it.



PUTAH CREEK.

EDGAR A. COHEN.



Figure 2.

WHEN GREEK MEETS GREEK.

Illustrating article "Photographic Selections for 1920," by Dr. R. W. Shufeldt.

PHOTOGRAPHIC SELECTIONS FOR 1920

By DR. R. W. SHUFELDT



MY private collection of negatives at this writing runs far up into the hundreds; and it is with no little pride that I can say that over seventy-five per cent. of them, or even more, have been published. There are no films among them, while the dry plates are in three sizes—five by eights, six and a half by eight and a half, and eight by tens; possibly there are a few scattered five by sevens, less than half a dozen—not more. Prints have been made from all of these and filed away for use as occasion happens to require, and in going over these a few days ago, I selected half a dozen subjects, no one of which had ever been published before, while all of them had been favorably commented upon by competent critics. Figure 1, which I have entitled "The Book of Fate," was made many years ago in my New York City studio, at the time I was preparing the illustrations for my work on "Studies of the Human Form," a volume which is now out of print. The negative is

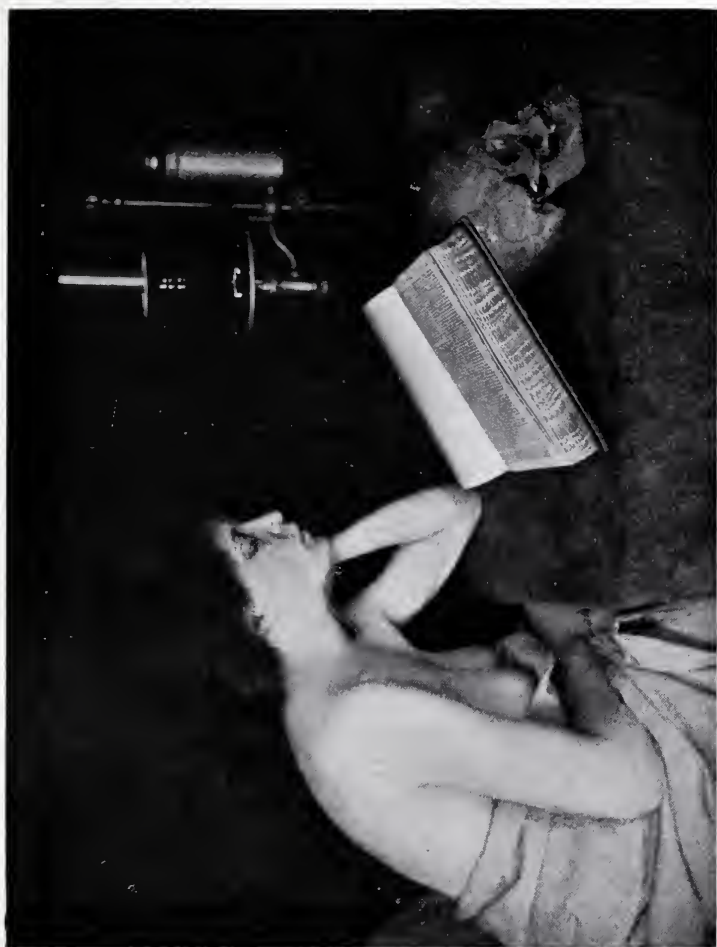

Figure 1.

THE BOOK OF FATE.

Illustrating article "Photographic Selections for 1920," by Dr. R. W. Shufeldt.

an eight by ten, and the composition, posing, and making all entirely my own. Better to leave to those of imaginative minds to frame for themselves a story which this would fitly illustrate, than to tell one here which might not appeal at all. In any event, there is sufficient in its make-up for a bit of romance, as the young reader is of pure Jewish stock, and was a model of mine for a long time. The skull is the skull of a murderer, whose body I purchased and dissected during my long course in the medical school; and, finally, the lamp was my study-lamp during my college days at Cornell, nearly half a century ago. As to the book itself—better leave it a matter of conjecture for future students of the picture.

Throughout certain parts of the South, from Georgia to eastern Texas, we meet with an immense black grasshopper, with short red and black inner wings. It is known as the "Lubber grasshopper," and its life-history is quite interesting. Years ago, when I collected them in Louisiana, they were known as *Romolea microptera*, the specific name referring to their small wings. Through the lower Atlantic States we find pale, dun-colored specimens; but I believe entomologists consider them to be the same species. A friend of mine, Mr. R. H. Young, of Haines City, Florida, sent me the two fine males herè shown in Figure 2; they came from his locality by mail, safe and sound, and I made the negative in my own study in Washington. Well may this scene be entitled "When Greek Meets Greek," as there is no love lost between these two old males when they confront each other during the mating season in the spring.

A large part of my photographic work of recent years has been devoted to the local flora of the District of Columbia, southern Maryland, and northern Virginia. About 500 negatives of this class of subjects have been made by me, and a great many of them have been published to illustrate my botanical articles in *American Forestry*, of Washington, the official organ of the American Forestry Association. Four such studies are here reproduced, no one of which has been published up to the present time. They were all made natural size on 8 x 10 negatives, and in the studio, and they are intended to exhibit the intimate structure of the several plants they represent. To obtain such results one must not only be



Figure 3.

THE MAY APPLE OR MANDRAKE.

Illustrating article "Photographic Selections for 1920," by Dr. R. W. Shufeldt.



Figure 4.
RED CLOVER.

familiar with all the tricks of landing such specimens fresh and perfect in front of the camera, but one must also know how to pose them after one gets them there.

In Figure 3 there is presented an interesting picture of the well-known May Apple or Mandrake (*Podophyllum peltatum*). We have here a perfect flower, so posed as to give all of its external parts, while near it is another flower with some of the



Figure 5.

THE TURTLE-HEAD.

Illustrating article "Photographic Selections for 1920," by Dr. R. W. Shufeldt.



Figure 6.
BLACKBERRY-VINE IN BLOSSOM.

petals removed, in that the form of the ovary, stamens, and anthers may be observed; enough of the leaf is included to show its general form. In the lower right-hand corner we note another leaf that, in coming up in the early spring, passed, while young and unrolled, through a hole in a stiff and dried oak leaf, causing strangulation. Possibly, as the growth of the former proceeds, the expansion may tear the dried leaf asunder; but even should this happen, the mandrake leaf will be sure to exhibit some deformity as it arrives at maturity.



NATURAL BRIDGE.

WARREN R. LAITY.

There is no greater favorite among American plants than the common Red Clover of our pastures (*Trifolium pratense*), and Figure 4 shows a number of the heads of this species, the bunch including the leaves, stems, some undeveloped heads, and other parts. Having been taken natural size upon a fine 8 x 10 plate, all the details are brought out with remarkable clearness. Note how well the peculiar markings on the leaves are defined, and how some of the latter are skilfully arranged to form a background for a flower-head on this side of it.

For plants having chalk-white flowers, as in the case of the Turtlehead (*Chelone glabra*), here shown in Figure 5, it is sometimes advisable to use some other kind of background—and for very obvious reasons. In this picture a wooden drafting-board was employed for the purpose, the color of which was that well-known shade of dressed pine that has been in use for a long time—a sort of buff yellow. It lends a peculiarly artistic effect to this interesting flower and its bunches of buds that appeals to many. The black, hairy caterpillar on the middle of the stem is an added point of interest which will at once attract the eye of the entomologist familiar with the species. Most of the leaves of this study have taken very dark; still, at least two form exceptions to this result, showing both contour and venation perfectly. This would never do in the case of such a leaf as our common wild blackberry possesses (Figure 6), as not only is it diversified in character, but the venation is deeply sculpt and remarkably elaborate; a fine example of these leaves is shown in the upper left-hand corner of the cut. As the petals of blackberry flowers fall off on the slightest provocation, it is no easy matter to secure a result like the one here shown. The branch was a long one, so it could be carefully divided with a sharp knife at *two points*—one towards the main stem and one towards its free end. In other words, it is a mid-third section of the branch, and at a point where both buds and blossoms are at their best. One or two of the latter have good leaf-backgrounds, others only partially have this advantage; this lends great character and clearness to the result. Of course, buds of a plant like this will take care of themselves, as they are nearly globular and largely covered by their sepals, all of which ensures dark outlines for them.



JOHN HENRY.

EDNA LEIGHTON TYLER.



PALM FRINGED SHORES.

Illustrating article "With the Camera in Florida," by F. W. Hill.

WITH THE CAMERA IN FLORIDA

By F. W. HILL

*"The stormy winds do blow
And I think we will have snow."*

WHO, when these lines come to mind does not have visions of the Sunny South where the stormy winds are hushed and the snow is only a memory, few indeed, the ever increasing army of tourists that make Florida their winter playground is proof positive that the Sunny South has more charms than the Wintry North.

Some of these ever increasing throngs will undoubtedly be amateur photographers. I do not mean snap-shotters, as most every tourist packs a kodak and pushes the button, but it is the real photographer I mean, one who is endeavoring to take



Figure 1.

MOONLIGHT AMONG THE PALMS.

Illustrating article "With the Camera in Florida," by F. W. Hill.

pictures worth while, to him a few words about his opportunities and disappointments.

If he comes from New England he will miss the rock-bound coast with its waves and dashing spray. Instead he will find broad sandy beaches lapped with a gentle surge, he will miss the hills and valleys to form backgrounds for his landscapes and view-points for his vistas. Instead he will find broad stretches of level sparsely timbered land or dense swamps with their tangle of tropical trees and vines. The winding roads he is used to will be replaced by the narrow ribbon of brick that leads straight through the trackless pines for mile after mile, but here and there, he will pass through strips of dense hammock land with its massive live oaks festooned with their long streamers of Spanish moss, and again through cypress swamps with their huge bluffs emerging from the mud and ooze and tapering gracefully aloft.

To those who come from the Middle States the general scenery will undoubtedly be more familiar. But, for those who come from the Pacific Coast, they will miss the rugged grandeur of mountain and canyon. No, you must not look for the grand or sublime in Florida, but to the calm and peaceful, and with this in mind there are many beautiful views to be had of placid ponds and rivers with their overhanging trees and palm-fringed shores.

So far, I have considered only the landscape possibilities, but there are many others, for instance, St. Augustine, is the oldest city in the United States and many of the old Spanish houses and the old Fort San Marco offer both interesting and pictorial material, while scattered along the East Coast are the ruins of the old Minorcan stone houses, ancient sugar mills, and near New Smyrna is a ruin of an ancient monastery claimed to have been built by Columbus when he first landed on the coast of Florida in 1492.

Then you have the ever present darkey doing his humble tasks about home or farm, always ready to grin at sight of a camera or dime, but ye tourists cannot see him at his best as the watermelon season is in the summer-time.

For the naturalist, there is always the chance of a sleeping alligator on the banks or a coiled rattlesnake by the roadside,



GEORGE FARREN.

Blanche C. Hungerford.

either of which will afford interesting material if he has patience and courage to approach them.

Now, a word about light conditions, remember it is winter-time and the sun is its weakest. The bright sunshine and the clear blue sky are apt to be deceptive as to exposure, the very brightness, which is due to lack of moisture of vapor in the air tends to make the shadows darker, as vapor in the air acts as a reflector and tends to throw light into the shadows. As one exposes for the shadows, observe this and give ample exposure, I have never found $1/25$ seconds at F $6/8$ on a Class I plate to be excessive on a well lit landscape, and if there are deep shadows more will be to the advantage.

To those who care for night pictures the moonlight is particularly brilliant, and many charming night views can be secured, I wonder how many ever thought of it that there is one night each month when genuine moonlight pictures can be made with the moon in it. This is the night before the full of the moon, when the moon rises just before the sun sets and has gotten sufficiently high to figure well in a picture, while there is still sufficient twilight left to give ample detail in the shadows with 60 to 90 seconds exposure, which is not sufficient to seriously elongate the moon, at least not so but what it can be easily retouched to a round. "Moonlight among the Palms" (Figure 1) was taken this way 90 seconds, exposure F $6/8$, Wellington Anti Screen backed plate.

I have tried to outline a few of the possibilities of the south from an artistic standpoint both with pen and picture, and I am in hopes that some of the readers of the *Annual* will have the opportunity to come and do likewise, and be sure if they look for them in the right place, and with the proper spirit, they will carry home many pleasing pictures as a result of their visit to Florida.

COMBINED DAYLIGHT AND FLASHLIGHT

By GEORGE W. FRENCH



HOTOGRAPHY, like every other field of science, has its several phases, some of which appeal to one group of enthusiasts, and others which present entirely different attractions to a second, third, and so on, set of workers.

No matter what field we choose, however, there are always two roadways lying before all of us. One leads along the line of least resistance; the other is beset with many obstacles. The first road is that which presents to the amateur, subjects that can be handled without any considerable expenditure of time and study. The second road is that which presents subjects requiring a great deal of patience and untiring effort, if success would be insured.

All of us travel along road number one when we first begin to feel the inward surging of emotion which clamors for vent in something of an æsthetic nature that is visible to the "naked" eye. If we are content to saunter along this route, we may eventually become producers of beautiful work, but we shall by no means reach a degree of skill that will enable us to do work which will appeal to the art critics—those who as a result of years of tireless practice and investigation have discovered methods and acquired skill that has enabled them to produce much-admired works of art.

Now before I continue I feel that I should make my motive clear, lest readers of this article get the impression that humble I, with my three years of puttering and dabbling in advanced work, am posing as an expert. No, sirs! I am as ready to be shown now as I was sixteen years ago when I toted around a box camera, snapping this, that and every other sample of the three material kingdoms.

Whatsoever conceit I may have developed as a result of recent mediocre success in the field of photographic art, is due to a desire to succeed as a reproducer of simple yet difficult



A CRITICAL POINT. Figure 1.

Illustrating article "Combined Daylight and Flashlight," by George W. French.

subjects. So in taking up the subject chosen the fact that some progress has been made along roadway number two, the more difficult road, lends confidence to my pen.

One secret of success in photography lies in one's skill in securing on the negative a proper rendition of lights and shadows. During the day, all objects present to the eye various degrees of light and shade. No scene that is worth an exposure exists in lifeless black and white; and yet how many such counterfeits appear in albums and photo magazines.

In the open, the preventative of such a result is ample exposure, together with the color screen and orthochromatic plate, further insured by the use of soft printing mediums. But inside, these agencies alone are not sufficient, particularly where there are forms which possess nervous systems and thus are so constituted that the chances of prolonged exposures are reduced to the minimum. To illustrate:

Figure No. 1, "A Critical Point", is a subject where physiological expression is the vital factor. The obstacles to be met in this as in all ordinary indoor genres, are extremes of light and shade, poor light within, and the tendency for the subjects, because of prolonged exposure, to move.

An unadulterated bulb exposure here of sufficient length to insure detail in the shadows would have resulted in excessive halation around the apertures, no detail through them, and very likely a blurred expression on the part of the human elements. (That the picture is devoid of blur is always a cause of wonder when it is considered that the older gentleman was eighty-four years of age at time of exposure. Both men are typical Maine characters.)

The preventative of these difficulties was the artificial lighting from within, produced by the auxiliary flash. Of course such procedure entails more expense, and considerable patience both on the part of the executor and the executed, but the result is apt to be well worth the trouble. Nothing of value is ever secured without a sacrifice on the part of some one. The picture that requires care and study in its production, and oftentimes many experimental plates, is the one that will occupy a reserved section at the salon.

We have discussed one or two advantages of this type of work. Another is that which results from the tendency of the



THE CASUALTY LIST. Figure 3.

Illustrating article "Combined Daylight and Flashlight," by George W. French.

vista effect to produce pleasing impressions, for there is no more charming color scheme than that produced by the light of day streaming in through open windows and doorways and filling the interior with soft mellow light. Such themes have been the favorites of several of the world's greatest painters.

The range of subjects that can be employed in this class of work is wide. To a large proportion of art lovers, pictures containing forms of life in their habitats, engaged in their conventional vocations, offer a strong appeal. It is a simple matter with a fast lens to snap a man in the act of swinging an axe, or pushing a saw, or lifting a barrel, but it is another and far more difficult task to secure a good picture of the same subject inside, and because of the difference in number of these two classes of work, and the advantage of the latter in securing pleasing lighting and composition, it results in more striking genres.

Now as to the method: The lens need not be of the speedy type, in fact a slow lens is better for several reasons not mentioned here.

The camera should possess a swing back, and the plate should be either double-coated or backed.

After the focusing is done *through* a wide aperture, the shutter should be set on T, and the subjects disturbed as little as possible while the flashlight preparations are being made.

Set a stand directly behind the tripod. On top of it, place a wooden box sufficiently high to project above the camera for about six inches. Place on end on top of the box a white cardboard box of about four inches in depth, and at least ten inches high. Pull and roll a tuft of cotton into a fuse, four inches long. Spread one end of this and place it on the bottom inside end of the cardboard box so that about two inches of the fuse projects over the edge. Then pour the necessary amount of powder on its spread end. When everything is set up, the powder should be about six to ten inches above the camera and about a foot back of the lens. The inside of the box will serve as a reflector.

Now pose the subjects, draw the slide, and with one hand on the bulb, ignite the fuse. When the flame reaches the edge of the box, duck and press the bulb, and press again immediately after the "pop."

Results will depend upon the size of the flash, the length of time during which the lens is open and quick action in closing the shutter almost simultaneously with the flash, for the subjects are apt to jump and thus change expression or position when the explosion takes place. The plate should be developed for a slightly thin negative. Pyro is an excellent developer if used rather weak and absolutely fresh.

"Bending to the Task" (Figure 2) received seven seconds plus a small flash. One second at F 6/3 was intended, but the flash was partly a fizzle and thus the long exposure. To prevent halation, development in a special solution was necessary.

In "The Casualty List" (Figure 3) a slight local reduction of the windows was necessary.

As is here illustrated, very novel schemes can be worked up, and the fun of the experiments, as long as the models are good natured, is worth a lot.

One of the best wishes that I can express for all who attempt genres of this kind, is that you can find such patient, kind and generous models as are represented in these pictures



Figure 2.
BENDING TO THE TASK.

PHOTOGRAPHY AND NATURE STUDY

By A. E. DAVIES

*"In nature there is nothing that is uninteresting,
There is nothing that is unimportant,
Nothing that is fully understood."*

DAN BEARD.

WE might add nothing that is unworthy of portrayal. In a way that is what a good many of us endeavor to do. A good percentage of the subjects that we turn our cameras on and our attention to is the work of nature. Likewise most of us only see what appeals to us as being the big things in nature. Those subjects that are commonly adjudged as being small, that are passed over day after day are just as worthy of our study as the giant tree, and when we do finally appreciate this fact and devote our attention to them, then do we realize their relative size. As our interest and experience with the details increases we see the millions of subjects around us that are worthy of photographic study, subjects that will require far greater technique and more patience than ever did, the bit of landscape that we traveled miles to record on our plate or film.

To illustrate this, on a walk in the hills last fall my friend and I had tramped all morning without exposing a single plate. Noon came and the stop for rest and lunch. The coming afternoon light afforded a fine view of "Old Grizzily" (Figure 1) and the relaxation gave opportunity for investigation of our immediate surroundings.

Birds, insects, plants, flowers, moss and many other things were there to occupy our attention. However, the first thing to really arouse our interest was a small lizard whose curiosity got the start of his better judgment. He crept up over the top of a rock to have a look at who had been so bold as to disturb his noon siesta, a slight move on my part and he scurried away. However, he soon came back, and in the same place. This made me get the reflex trained on the top of that



BROWN'S LANE.

A. B. Hargett.

rock and the next time he looked over I was ready for him. The better part of two hours was spent watching him, and I not only got some good pictures of the Pacific Swift, but I learned something of his habits at the same time.

This experience got us away from looking for composition in the grand view, and the remainder of the afternoon was very pleasantly spent studying and photographing the many and interesting details of nature, all within a hundred feet of where we camped for lunch. When we finally did start for home it was with a full case of exposed plates, and the thought that there was much left to come back for another time.

Don't expect to get a picture every time you expose a plate, rather not in a good many instances. If you miss it the first time try again, know more about your subject when you go back the second time. Your interest will be increased and you will know better just what you wish to portray. If your interest in nature increases and you profit by your experiences you will find not only your number of possible subjects multiplying, but they seem ready and waiting, willing to co-operate with you.

You know there is no closed season for the hunter with a camera, and the photography of birds and animals does not deprive your subjects of their life and freedom. The satisfaction in getting a good picture of wild life is bound to be much greater than in the slaughter, as your skill has got to be greater to get a near and clear view of your subject. As a student of nature you will find no better ally than your camera in the close observance of those things about you.

As to apparatus nearly every one of us has a theory as to the ideal outfit, but as each ideal is formed upon individual experience, they are hardly ever alike. Personally I like a long draw, reflex type camera the best, although I have seen the time when I thought this was quite heavy. One thing—long bellows is almost essential, and another, not alone in nature work, but in most photography, a longer focus lens than most of those now popular is an advantage.

A small part of a negative often makes a more pleasing picture than a print the full size of your negative. One of the reasons is that when making a print from only a small part of an average negative you embrace a narrower angle

of view, more nearly approaching the natural angle of vision of the human eyes, namely 20° . This point is especially emphasized in lantern slides, for when a picture embracing a wide angle is projected, one is unable to view as a whole, but has to study different parts of the picture. This applies to prints as well, although being on a smaller scale it is harder to define.

I prefer $3\frac{1}{4} \times 4\frac{1}{4}$ for size, and use for the most part a lens of eight inch focal length, sometimes a twelve inch lens—the latter is convertible to double this. A lens equipment of this character on $3\frac{1}{4} \times 4\frac{1}{4}$ not only gives good perspective, but is a great aid on those subjects that are difficult to approach.

For photography in connection with nature study use orthochromatic plates or films. If you use plates, go a step further and use panchromatic, wherever possible, with the proper color filter.

The above remarks apply to an ideal outfit. However, don't forget that contrary to what sometimes seems to be the general opinion, the apparatus is not the whole story. Just because you make a good picture, isn't all because you have a fine lens, and whatever outfit you have remember the quotation from Dan Beard, go out and study nature, let your camera be your helper.



A COMING SHOWER.

ADDIE M. HARTMAN.



OLD GRIZZLY.

Figure 1.

E. W. FULLER.

Illustrating article "Photography and Nature Study," by A. E. Davies.

HOME-MADE TIME SAVERS

By C. ERWIN AYERS



OME years ago, while assisting for a short time in a busy commercial studio, I made two simple little devices that saved many moments each day. It was necessary to cut a large number of pieces of cotton cloth from the web to a size 12 in. by 15 in. This was done laboriously with the trimming board and took an hour or more each day. I took a piece of wood 20 inches long, 2 inches wide, and 1 inch thick. With some large headed tacks fastened an ordinary safety razor blade to one end of the wood so that as it lay upon the shelf the sharp edge of the blade was up some $\frac{5}{8}$ of an inch above the wood; then I marked off 12 inches and 15 inches from the edge of the blade upon the stick, and the device was complete almost in less time than it takes to tell how it was done (Figure 1).

In using the cutter, I simply placed one edge of the 36-inch way of the cloth against the 12-inch mark on the cutter and drew the cloth across the razor blade; repeating this from the other side divided the 36 inches into three 12-inch strips for an inch or two into the end of the web. It was then an easy matter to tear the 12-inch widths the whole length of the web, and by using the 15-inch mark to tear these 12-inch strips into the 12 by 15-inch pieces required. A whole web could be torn up in a few moments, where previously it had taken some hours to cut it up with the trimming board. By simply varying the gauge marks it would be possible to cut cloth for backing any size prints required.

The second device I consider a great improvement and time saver in trimming prints that are printed with a white margin and trimmed later, using the eye, or at the best, a reflected light from underneath the print as a guide. Take a piece of firm smooth cover paper and cut it the size of the outside of

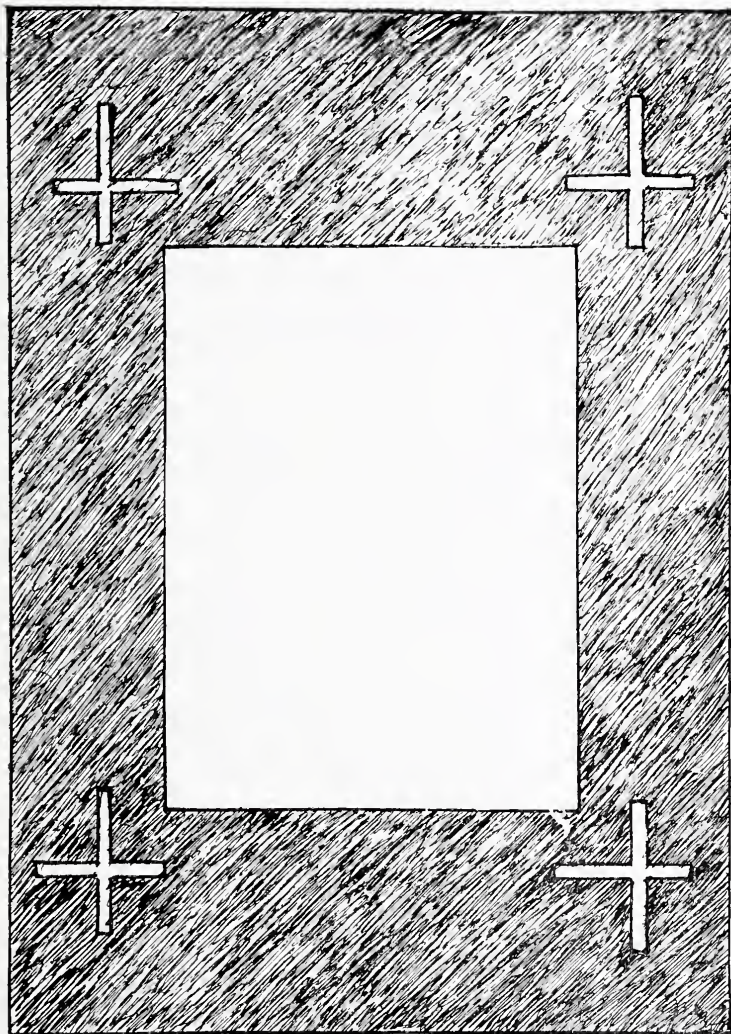

Figure 2.

Illustrating article "Home-made Time Savers," by C. Erwin Ayers.

your mask; then cut firm cardboard on your trimming board to just the size that you wish the opening in your mask, now lay the paper for the mask on cardboard and place the piece that you have cut for the size of the opening in the center, leaving an equal margin all around. With a sharp safety razor blade cut carefully around this pattern, and you will have a nice clean opening in your mask.

Next measure carefully from the opening in the mask and mark a line around the opening with exact width of your white margin on your prints. With the razor blade and a ruler or straight edge cut crosses from a sixteenth to an eighth of an inch across exactly at the outer corners of your marginal marks. The accompanying sketch will make it perfectly plain

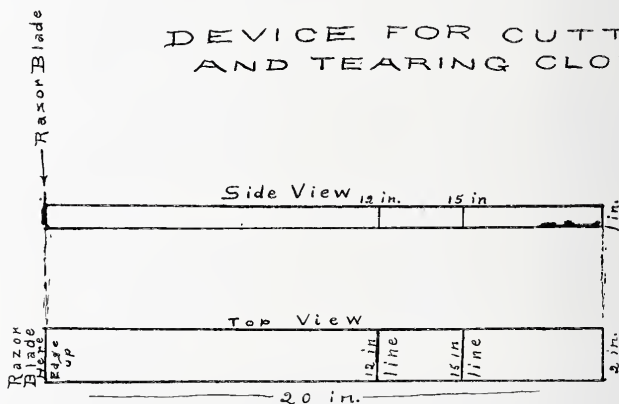

Figure 1.

how this is done (Figure 2). Your mask is now finished and each print will have black guide lines for trimming, and can be trimmed as fast as you can place them upon the trimming board, best of all, with absolutely even and accurate margins. A later variation of the above was made by placing guides of thin cardboard even with margin lines on one side, and one end of the mask, and cutting the crosses or openings for the guide lines only on the other side and end of the mask as required. By using this later method four or five prints could be stacked, trimmed on the two sides as required and were all finished.



AMANITA MUSCARIA.

EDWIN A. ROBERTS.

THE EXIGENCIES OF COMPOSITION

By EDWARD R. DICKSON



AFTER all, composing the picture is merely a matter of appreciating the relation which one object bears to another within the space of our ground-glass or finder. It is the means through which we arrive at harmony, and parallels man's effort to establish through union, a fine relationship with another human. As you know, however, like the pictorialist and his camera, such a relation is not always attained.

One of the common habits among photographers is that of a worker making an exposure which is supposed to please him. After printing his picture he suddenly finds that a wee space somewhere in the vicinity of the middle or sides of his picture seems more interesting to him. He therefore proceeds to enlarge the section to many dimensions; mounts the now completed product and presents it as a choice which he has made from "chaotic" Nature. You will readily see that such a practice cannot further the progress of the photographer or make him realize the exigencies of composition, for if his original choice had been actuated by deliberation and comprehended selection, there would be no need for this belated discovery. He simply failed in a "hit-or-miss" choice—a continuance of which will never let him achieve mastery in his work.

It has often been said by others: "Oh, I don't take my photography seriously, you know. I have lots of fun with it." After talking with these people, one finds that they do really have serious ambitions in pictorial photography, but are too modest to state them. When, logically, a group of their prints is rejected by a jury which confirms their opinion by not taking their work seriously, they frantically attack what is known as "the perils of the jury system and how to abolish them".

To compose a picture we must first acquaint ourselves with the anatomy of picture-making. Like the architect, we must



THE WEARY SCRIBE.

Louis Astrella.

construct it firmly in its frame or boundary line, or it will slip out and fall before us. It is neither necessary to show its beams and girders, nor its plans and details. These constitute our inner knowledge and are the exigencies of composition which we as craftsmen are using in a structural sense. The beholder is to delight in our finished product; that is our intention. Now, we cannot know where best to place these supports without a study of their disposition in a given space. Knowing where to place them rightly will add strength to our picture-house and make it withstand the stress of weather. We are going to use the flimsiest material in making this house—God's fleeting sunbeams—and we must be as sensitive to its use as we can ever be. Our touch must be lightest and our handling most delicate, or our material will break in our very hands. As soon as we have learned the relation which one object bears to another and have become sensible to harmony or discord in the manner of this relationship, we begin to feel an intimacy with the worth or value of each object; how the importance of the tree which we want to emphasize has become nullified by the inclusion of distracting details in the path of our vision; and how incorrigible highlights are clamoring for attention whereas your intention is to have them play minor parts. These are the things which we are going to be sensitive about and learn to control. We are going to decide where our emphasis in our picture must be, and, excluding by choice anything which is likely to interfere with our scheme of harmony, make our exposure. We will not include all which our eyes see, for we know that we must choose and the more we discriminate the finer will be that choice. Aspiring toward real progress, we will not be influenced by our loyal and sympathetic friends, for we know that a discerning colleague is by far the best acquisition. If we learn to fill our space adequately and fully, we will finally be masters of composition and, later, learn to fuse this knowledge with the beauty of our own spirit.

In the accompanying picture "High Bridge", one of a series I have made in order to bring to the attention of the New York authorities the beauty of an old bridge which they contemplate destroying so as to meet the needs of commerce, you will observe that emphasis has been laid on about one-third of

the picture-area (the upper part). The railing to the left has been used to give impetus to the eye as it searches the space, for composition is intended to make the eye subservient to it. The rock at the right stops the eye from an exit there and compels it to rest on the beautiful arches of the bridge. These six arches have been selected so as to divide unequally the horizontal space of the picture. If they were divided equally



Figure 1.

the composition would become formal and rigid. The bridge has been placed in its present position in the space to give it loftiness of height and of feeling. The shadows in the foreground serve as an entrance, for the eye, as it skirts the tips of these shadows, is led toward the rock and its base; to the arches and back to the railing. The eye would never rest tranquilly on the bridge if the foreground were brazen with



HIGH BRIDGE.

Illustrating article "The Exigencies of Composition," by Edward R. Dickson.

sunlight or altogether empty. The shadows are translucent and their varied forms are not only delightful but conform with the general direction of the winding railing. As you will see, the entire picture-area has been broken up into irregular parts to give an unsymmetrical balance to the pictorial scheme. The delicacy of tones has been secured by a full exposure and a duration of development necessary to retain the vibrations of light.

In order to give a more comprehensive idea of its composition and adherence to a deliberate design, the accompanying sketch (Figure 1) has been made so that the student may realize the structural importance of design in his photographic work, and its use as an inner motive beckoning the spectator to enter into such sensations as the pictorialist has prepared for his delight.



QUEENSBOROUGH BRIDGE.

JOHN LEWISOHN.



BRIGHT AND BREEZY.

WILLIAM FINDLAY.

A PLEA FOR THE SINGLE LANTERN

By G. T. HARRIS



IN these days of widespread cinema performances the single and biennial lanterns that afforded so much pleasure and entertainment to the last generation are apt to be regarded as old-fashioned and useless for popular audiences. An experience last winter, however, gave me the impression that there was still a niche for our old friend the single lantern slide. I was asked to give a lecture in a large city in the West of England. The lecture was to be one of a series of educational lectures given through the winter by the city museum authorities, and were of a popular scientific character. The choice of a subject was left with myself.

With some trepidation I asked the curator of the museum if a lantern would be forthcoming if I decided on illustrating it with lantern slides, and he good naturedly undertook to provide one. I got to work and made about one hundred and twenty slides to illustrate the lecture, "A Naturalist in the New Forest." The lecture dealt with all phases of the life and history of the forest. Slides were made to illustrate the scenery, wild-flowers, insects, birds, animals, etc., peculiar to the forest area. With few exceptions all were from life, as I had a good series of botanical and zoological negatives by me. About fifty per cent of the slides were carefully hand-colored, the remainder were varied colors of brown and black. Hence there was no monotony on the screen.

I found that my friend the curator had engaged a really fine lantern and a very competent operator, and in spite of the three or four cinemas running in the city the lecture hall was well filled. Any doubt I might have had regarding the popularity of the single lantern was quite dispelled by the unqualified success of the evening's entertainment, and the curator was desirous that a similar lantern lecture should appear in



EBB TIDE.

G. T. HARRIS.

the next winter's syllabus. So much for the popularity of the single lantern. Given good slides, well varied, well exhibited, I am convinced that it really comes as a positive relief to the now ubiquitous cinema.

Making lantern slides for the single lantern is in danger of becoming a lost art. The meticulous care expended on a lantern slide by the enthusiast of twenty years ago would probably excite the derision of the majority of photographers of to-day, but the lantern evenings of metropolitan photographic clubs bore unimpeachable witness to the success of their methods. The contest for supremacy lay between collodio-bromide and gelatino-bromide, with its variants, gelatine-chloride and chloro-bromide. Unmistakably collodio-bromide, either washed or unwashed was a fascinating process to work and yielded superlative results. Wet collodion was *par excellence* the professional lantern slide maker's process, and gave brilliant results with a minimum of trouble. But the proper place to judge a lantern slide is when it is projected on the screen, and here the gelatino-bromide slide will hold its own for artistic merit against collodion wet or dry.

The emulsion work for gelatino-bromide plates is simplicity itself. Last winter when preparing the lecture referred to above I found myself without lantern plates. The war was on, and the prices of plates were designed by a "ring" to establish a fortune unto the third or fourth generation. Under these circumstances I decided upon making a batch as I had the necessary chemicals by me. Here is the formula, which will coat one gross of lantern plates:

A. Nelson's No. 1 Gelatine.....	40 grains
Potassium bromide.....	100 grains
Sodium chloride.....	25 grains
Hydrochloric acid.....	3 minims
Water	5 ounces
B. Silver nitrate.....	200 grains
C. Hard gelatine.....	200 grains

Place the bromised gelatine in a vessel of water and raise the temperature to 60 deg. C., drop in the silver nitrate *dry* and shake vigorously until it is all dissolved. The result will be a creamy emulsion, ruby by transmitted light. It may with advantage be put back in the hot water bath and digested at 60



AN OCTOBER LANDSCAPE.

KENNETH DUDLEY SMITH.

deg. C. for ten minutes. This will improve the rapidity, which will be an advantage if the plates are to be used in the camera for reduction slides. After the emulsion has been digested for about ten minutes it is set aside to cool and thoroughly solidify, which process had better occupy at least twelve hours, unless a refrigerator is used. When set quite firm it is squeezed through coarse canvas into a vessel of cold water, allowed to soak perhaps fifteen minutes, when the water is changed. After about two hours soaking and changing the emulsion is collected, well drained and re-melted, a crystal or two of thymol being added unless all the emulsion is used up straight away. When filtered the emulsion is ready for coating.

The plates should be coated very thinly, as the ruby colour of the emulsion prevents all tendency to halation caused by a thin film. Drying takes place quickly owing to the thinness of the film. A drying box is easily made out of any conveniently shaped box made light-tight, and with a false bottom and top, the ends of the box proper being pierced with an inch hole to permit of the ingress and egress of a current of air. My drying box holds half a gross of lantern plates, which, coated at night, are all dry by the following morning, a small lamp being placed below the hole in the end of the box serving to admit air.

Plates made by the above formula give a range of colour from pure black to warm red, dependent on length of exposure and character of developer. And here let me interpolate the remark that it is much better to have a good variety of colour in a series of lantern slides than one unvarying colour, however good. It is an axiom in lantern slide work that short exposures and normal developers give black and warm black colours. Lengthening the exposures and restraining the developer give warmer colours, even reds. At one time the addition of ammonium carbonate to the developer was the royal road to warm rich colours in lantern slides and years ago I achieved some extremely gratifying results; but alas! the beautiful warmth conferred by the ammonium carbonate gradually vanished from the slide, leaving a dingy warm black in its place. The following developers have been used for plates made as previously stated, but any standard lantern slide developer will give satisfactory results.



O. C. CONKLING.

For black colours amidol is excellent, but is very rapid in action, and a slide that looks dense enough before fixing may be but a ghost on leaving the fixing bath.

Amidol	20 grains
Sodium sulphite.....	240 grains
Potassium bromide.....	10 grains
Water	10 ounces

The following pyro-ammonia is very reliable for pleasing warm brown colours :

A. Pyrogallol	30 grains
Sodium sulphite.....	120 grains
Citric acid.....	3 grains
Water	10 ounces
B. Ammonium bromide.....	40 grains
Liquor ammonia (.880).....	30 minims
Water	10 ounces

Equal parts to develop.

Care must be taken when developing for warm colours not to develop too far as unlike the black tones the warm colours leave the fixing bath much denser than one would judge them to be when developed. If very warm colours are desired recourse must be had to ammonium carbonate, which may conveniently be kept as a 10 per cent solution and ten or twenty minims added to the ounce of developer.

An excellent method of obtaining warm colours is by way of a good black image subsequently toned by potassium ferricyanide and sulphide of soda, as when toning bromide prints. Veil or stain of any kind must be carefully avoided if brilliance of image on the screen is desired. On the other hand, a very vigorous image is very far from pleasant when projected. Strive to obtain a slide that will give a soft well gradated image on the screen with just the extreme high lights having some sparkle.

It is not an easy matter to hit the best opacity when developing a lantern slide; it often happens that the slide is just too dense or just too thin. Of the two faults the latter is preferable. It is quite easy to give it the additional slight opacity without interfering with the quality of gradation in the image, but any attempt at reducing a slide too dense is very likely to end in disaster. Probably the best intensifier for conferring



THE CORNER.

HERMAN GABRIEL.

a slight additional opacity is a silver nitrate intensifier, and the formula below is the one I use.

A—Hydrokinone	20 gr.
Citric acid.....	20 gr.
Distilled water.....	20 oz.
B—Silver nitrate.....	20 gr.
Nitric acid	5 mins.
Distilled water.....	20 oz.

Equal parts are taken to intensify. The plate should be well washed from the fixing bath, placed for a time in an alum bath and again washed. The slide gains in opacity somewhat on drying when the silver intensifier is used, so allowance must be made for this. If reduction is absolutely necessary the ferricyanide used very weak may be employed.

The inclusion of a few coloured slides in a lecture is a great help in retaining the attention of an audience. My experience is that a badly coloured lantern slide attracts an average audience far more than the highest class monochrome slide. Even a small amount of colour on the slide is very effective and enables it to pose as a coloured lantern slide. It is quite within the power of the average lantern slide maker to tint his slides well enough to escape the destructive criticism of a popular audience.

The first lantern slides I ever tinted were included in a popular lecture on wild-flowers, and I was quite unprepared for the rounds of applause with which they were greeted. The principal thing is to use transparent colours, work with a full brush, so that the tints are flowed on rather than stippled on, and to avoid colouring too brilliantly until some experience has been gained. It may appear unnecessary advice.

My object in writing these very casual notes on the working of the lantern slide is to attract attention to an instrument that has become unfashionable, not inefficient, and to advance the claims of the popular lantern lecture as an intellectual recreation. Given a good set of slides and a well constructed lecture, the audience may still be found that will thoroughly appreciate such an entertainment. The secret of success is plenty of slides to illustrate one's remarks, a hundred slides for an hour and a half's discourse is about my own average.



THE SCOUTS.

Copyright by A. L. HITCHIN.



ELIZABETH.

IRVING BERKEY.

TANKS, DEVELOPERS AND EXPOSURE METERS

By FLOYD D. PALMER

EVERY one has his likes and dislikes in the matter of photographic apparatus and methods. The real pleasure in the game comes when one can duplicate his successes. A friend of mine who had viewed my sad early efforts said the other day, "Well, I suppose you are still spoiling a lot of perfectly good plates and paper, are you not?" and I had the pleasure of telling him that I was spoiling very little material at the present.

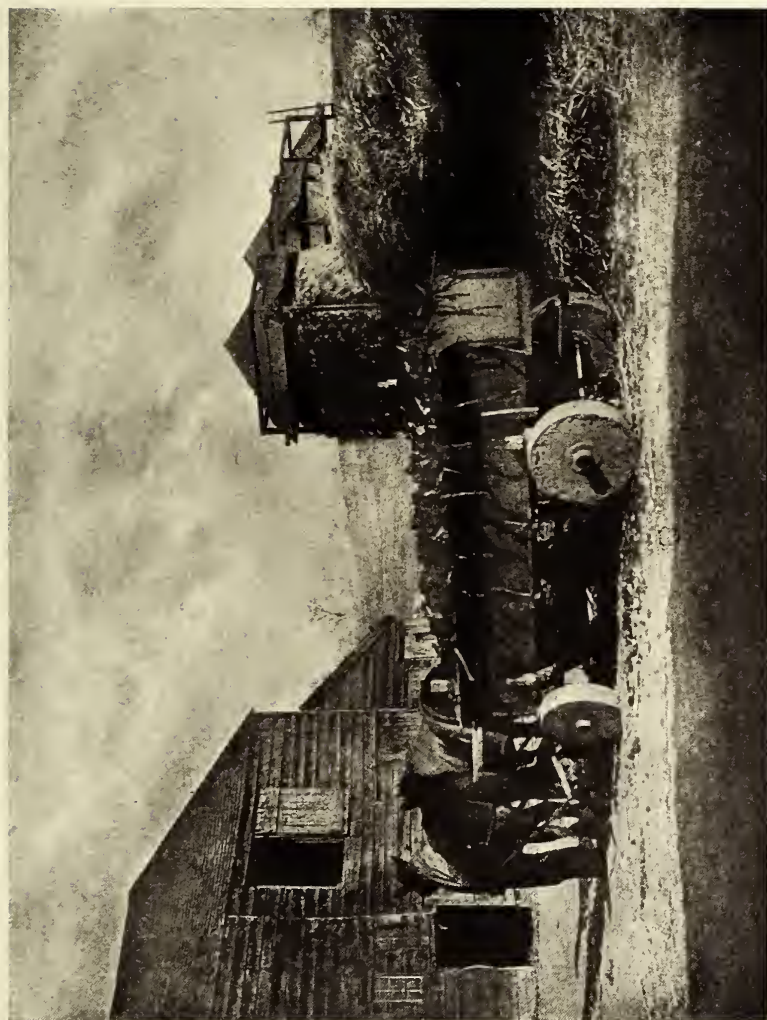

CHORE TIME.

August Krug.

Disregarding the purely portrait game, you will save money in the end by getting an exposure meter, a tank, and by studying the composition and action of your developer. There is no question whatever but "the experience is all in the tank." With the tank you can develop a dozen negatives to exactly the same degree of contrast—you can do it in thirty minutes too—and you do not have to stay in the dark-room either. Any one who has ever tried to develop plates in a hot dark-room in the summer can realize what this means.

With the tank you simply have to get your developer in the tank at the right temperature, put in your plates, clamp on the cover, set the tank in a jar of water at the same temperature and turn the tank bottom up every three minutes. At the end of a half hour they are developed, and if the contrast does not please you it can be corrected next time either by a change in developer composition, or by a change in the development time.

Most tank developers contain four main ingredients, water, sodium sulphite, sodium carbonate, and pyrogallic acid. In general the amount of sulphite controls the yellowness or greyness of the negative, too little giving a yellowish tinge and too much producing too gray negatives. The carbonate controls the speed of development, any excess making the developer work too fast. If the temperature and development time are correct, about all that needs to be changed is the amount of carbonate; leave the pyro alone. Less development time gives softer, thinner negatives with less contrast.

The Cramer tank developer I am using on Cramer Double Coated Medium Iso plates in an Eastman 32 oz. tank is made up as follows:

Water	32 oz.
Dry Sodium Sulphite.....	75 gr.
Dry Sodium Carbonate.....	20 gr.
Pyro	22½ gr.

The chemicals are weighed out one at a time and kept separate in small corked bottles until needed. The carbonate and sulphite can be mixed dry in the same bottle, but the pyro must be kept by itself, or it will turn black. Stock solutions are quicker to use, but they are dangerous. You do not measure a liquid as accurately as you weigh a powder. If you vary

any of the developer constituents try 10% change first. You are never sure when they have gone bad, and it is certain that if stock solutions of sulphite and pyro are kept in partly filled bottles they will deteriorate if you keep them long enough.

When these are dissolved in the order stated in the above quantity of water, used at 70° for 30 minutes, this developer will get everything out of the plate, and if your negative is not good the exposure was wrong. Do not mix your developer in the tank, dissolve the chemicals in water in a graduate, and then put them in the tank. In this way any undissolved particles can be seen. My method is to dissolve the sulphite and carbonate in 32 oz. of water in a graduate, put into the tank, and when all is ready drop the pyro in, and give it a few quick stirs with a stirring rod.

The double coated plate with its extra thick film, and color sensitive properties, is superior to single coated plates for usual and unusual classes of work. It makes good on easy subjects, and will do all a plate can do for you on the difficult ones. They will show a wealth of halftones when fully exposed that no single coated plate is capable of. Yes, they cost a little more, 72c per dozen in the $3\frac{1}{4} \times 5\frac{1}{2}$ size at present. If you want to use a ray filter you can do so on clouds, landscapes, etc., but in many cases the filter is of no advantage and may be a disadvantage due to the increase in exposure it makes necessary.

How any one gets along without an exposure meter I do not know. I would be lost without one. The Watkins \$5.00 one with the blue glass is the one to buy. Every class of subject needs special study. Just at present, for instance, I know that when making an exposure on a flower or a bird's nest, close up, in the shade, and using the above plate at its rated speed of 180, if I expose the plate just three times as long as the meter indicates, and develop it in the tank developer as outlined above, I will get a perfect negative. There is no doubt about it, unless the nest or flower moves and produces a blurred negative.

A portrait or group in the shade would call for the exact exposure indicated by the meter, a distant landscape would call for less than the meter indicates, etc. The farther away the subject the less exposure.



THE OLD MILL.

FARL A. NEWHALL.

Each class of subject calls for study to get the exposure right, and if the exposure is correct and your developer is so balanced as to give you the contrast you need for the printing paper you use, the process after exposure becomes practically automatic. You have to work out the proper exposure to be given each class of subject for yourself by giving it say one-half the exposure indicated by the meter, the exact indicated exposure and twice the indicated exposure on three plates; then develop in the tank and see which one is best. Of course any one who is in the game seriously will keep a note-book recording the exposure and development treatment given each negative. If you have not the grit to do this there is no use in trying to succeed. The amount of exposure fixes the shadow detail, the development fixes the amount of contrast, and the length of development fixes the general density of the negative.

Plates should be fixed on edge in grooved glass or rubber tanks. They require no attention after they are once in and covered up away from the light. The green chrome alum fixing bath is the best I have ever used. Even this will decompose and deposit sulphur if it is kept in a warm place. After washing, use it cool, about 55° - 60° . I stand my bottle in the ice box for an hour or so before using, the negatives should be given a five minute soak in a bath made by dissolving one part of formalin in ten parts of water to super-harden the gelatine film. Then the surface is mopped off with a wad of wet absorbent cotton to remove surface dirt and specks of gelatine. They are then stood on edge on pieces of blotter to drain and dry. If hardened in formalin they can be put in full hot summer sunshine to dry rapidly usually in ten minutes or so.

The exposure really seals the fate of the plate; if your negatives come out weak, thin, and transparent in the shadows you have under-exposed. If they come out black, dense, with little transparency anywhere they are over-exposed, and all you can do is to try again and change the exposure. I am blowing no horn for the Cramer plates and the Eastman tank; they have both served me faithfully with most difficult natural history subjects. It is really quite interesting to place a professional photographer experienced in studio work only in front of a bird's nest, on the ground, in the shade, lens stopped down to



THE SCULPTOR.

LAURA ADAMS ARMER.

F 6/4, and see what exposure he will suggest. Some professionals seem to hear, smell or taste the proper exposure to give; some say they "feel" how much time to give. Proper exposure in the above case often runs up to five minutes or more depending on the depth of shade aperture used, and the general brightness of the light out in the open.

Did you ever focus on a rare flower in a swamp ten miles from civilization, and see the mosquitoes go by on the ground-glass image, the ones not biting you I mean? Times like this is when the meter is your truest friend. The exposure is really all you have to watch out for; if it is correct the development will give you the exact detail in the shadows and the contrast you wish. If it is not correct all you can do is to record all the data in the note-book and try it again. It is really a most fascinating thing to study out the reasons why for success and failure. If you are seriously bitten by the photo bug get a tank, Watkins meter, thermometer, scales, and last and perhaps most important a notebook and pencil, and try it out. Don't try to record your notes three days after you have exposed and developed your plates either. Record your developer, composition, temperature and developer time too, also your exposure, stop, and light conditions. If after a year or so you can get ten perfect negatives from a dozen plates on mixed subjects you are on the high road to success.

These double coated plates will stand a great deal of over-exposure, at least four times the minimum exposure needed to produce a perfect negative, simply growing in general density as the exposure increases and not flattening out.

Any dry plate company will, on request, tell you exactly how many grains of sulphite, carbonate and pyro to dissolve in any given amount of water for average results on any individual brand of plate they make, and will tell you the proper time and temperature. You can try it, and by varying the amount of carbonate and sulphite get the exact color and contrast you want. The manuals issued by the plate makers usually call for stock solutions which are not to be recommended. Tray development by red light is bound to produce some fog, usually just enough to take the sparkle out of the negatives. The film of a double coated plate is so thick you cannot see through it to judge the image anyway.



SUN FLASH IN STORM.
CITY COLLEGE, NEW YORK.

Copyright by H. C. JEFFERY.

Keep your chemicals in tightly corked bottles. The Eastman anhydrous sulphite and carbonate are the ones mentioned in the above tank formula. The fluffy kind of pyro (re-sublimed) is handier to weigh in small quantities than the more dense crystal kind. I have never found that the minute amount of potassium bromide recommended for use in tank developers had any use, so have omitted it.

It is also well to go over your wet negatives with a large wad of damp (not soaking wet) absorbent cotton to remove all tear drops, and as much of the surface water as possible before putting the negatives in the sun to dry. This insures quick even drying.

It is also a most excellent idea to learn to dust, load your dry plates into holders, load the plates into the tank, rinse the developed plates in water, and place them in the fixing bath in absolute darkness. Any red light in the dark-room means possible fog. If you will do this you are certain any fog on your negatives is caused by something else than dark-room light. It is perfectly easy to do this by taking a few old plates, shutting your eyes and going through the motions. If you remember that plates come packed in pairs, face to face, you will not get them into the holders wrong side out. After a bit your fingers can tell the difference between the emulsion side and the glass anyway. Color sensitive plates exposed to any sort of red light before exposure are ticklish propositions at best. Many ruby lights will fog bromide paper, let alone a color sensitive plate, and if you hold a color sensitive plate up to within a couple of inches of a ruby light, and examine it for ten or fifteen seconds, several times during the process of tray development fog is sure to show. Examine the extreme ends of your negatives, that were protected by edges of plate holders; if they are not perfectly transparent you have fog. Do not put your plate cage into the fixing bath and do not fix in the developing tank. The exposure question is enough to keep one busy without having to worry about the cause of twenty or so other troubles that may or may not show.

Last and by no means least, is your dark-room light tight? Go in there in the daytime, shut the door, stay for five minutes, look around and see what you see. The hardware store will probably sell some felt strips and tacks right away. A



AN OCTOBER LANDSCAPE.

Lawrence Baker.

plate capable of making a fully exposed negative in $\frac{1}{500}$ th of a second is not going to stand for very much light through the key hole, or under the door. The plate companies are making some wonderful plates these days; let's give those plates a chance to show what they can do.



O. J. VOLKMAN.

COMPOSITION

By RICHARD J. GRACE



OUR editor critics, our free or Bolshevick critics, and last but not least our amateur advisors, are very prone to see nothing at first, but what they are pleased to call the "composition" of our pictorial efforts. Who has not heard of "leading the eye out of the picture," "out of balance," the latter carried to such extremes as the imagination of a steel yard, with an invisible fulcrum, by which a very large haystack in the lower left-hand corner is balanced by a diminutive cottage somewhere near the right-hand horizon. Again we have the inviolable rule of the "third" points, by which a critic will not pass a picture unless the object of interest is situated one-third of the picture width from the margin. Another rejects a picture wholly, exclaiming that it violates all "the laws of composition."

"The laws of composition." Let us ponder on this a moment. If there are laws of composition, there must be laws of art, and laws once established and published can be learned by the veriest tyro, and applied by him. We know there can be no laws of art, which is a matter of individual expression, in rare cases almost amounting to inspiration. This disposes of any possible laws of composition, and the critics occasionally admit this by their "composition is unusual, but pleasing." The Japanese are continually using this unusual composition very pleasingly. There might possibly be some axioms of composition, but there can be no set rules. One of these axioms might be that any arrangement that holds the eye to the principal object and so tells the story that no title is required for the picture, is good composition.

Certain little "tricks" also help composition, as in mountain photography, the reducing of the sky area will increase distance and height. Another is, providing a little space in front of an obviously moving subject, to give it room to progress,



A BRETON LAUNDRY CART.

W. H. WOMERSLEY

but these by no means can be called laws, or even rules. The man who is doubtful of his composition at the time of making his picture can very often make his subject occupy a small part of his picture space, and make his final composition later by trimming the picture, to bring the subject in the most desirable position.

In these days of the smaller camera and the enlarging lantern, I find this is the safest procedure. If your composition will hold the attention of the observer in the picture space and will convey the story so completely without distractions, that a title or explanation is unnecessary, your composition is good, all laws and rules to the contrary notwithstanding.



MOUNTAIN WILDS, ADIRONDACKS.

HARRY G. PHISTER.



ALICE BOUGHTON.

A PLEA FOR THE SMALL PLATE CAMERA

By G. H. S. HARDING

T is so frequently stated that photography is "too expensive an amusement" for most young people to take up seriously that I propose to show in this short article such is not necessarily the case, in fact it can be made quite inexpensive after the first outlay, and that need not be great if care is used in the selection of the outfit.

Few pleasures will give such lasting benefit and enjoyment as can be derived from the use of a small plate camera. Instead of going through the world with one's eyes shut, so to speak, you are trained to see pictures on every side that otherwise would be passed by unnoticed, making one's daily walk in life just that much more interesting and worth while. Photography is expensive because nearly every one uses films and has some dealer develop and finish his work. Of course it is expensive that way.

The average beginner is impressed with the fact that only some well advertised brand of goods (with the price made to include said advertising) is of any use whatever, and of course "you must use films because they are so convenient and everybody is using them." This talk is not for those who only want to "punch the button and let someone else do the rest," but for those who have some artistic taste and wish to give it expression without spending several years in an art school to learn how.

Films are convenient on long trips but cost nearly twice as much as plates. Also from the nature of a film camera, even an expert is tempted to shoot off twice as many exposures as the subject warrants, because of the ease with which a new film can be wound into place, and for a beginner this feature is simply fatal to his pocketbook. Therefore, take temptation away and also do better and much more interesting work by using a small plate camera.



THE HILLSIDE.

G. H. S. HARDING.

As far as convenience is concerned a plate camera is smaller and lighter than a film one of same size picture. If thin metal plate holders are used a dozen can be carried in the coat pockets, or a small case, and for special occasions a film pack can usually be fitted.

A tripod is no more necessary than for a film camera, and you have the enormous advantage of composing your picture full size on the ground glass and being able to focus just as you want it, then noting your boundary or some distinctive object, the small finder can be used to locate same while making exposure.

I find a $3\frac{1}{4} \times 4\frac{1}{4}$ size most satisfactory. Plates of this size cost only 45c. per dozen at present high prices, and you also have a wide choice, fast, slow, color corrected, etc., so you can select just the right kind for the class of work you decide to take up. Having made your choice, however, stick to it until you have thoroughly mastered its peculiarities, or you will waste a lot of material before you locate the trouble which is usually that you have mixed yourself up so, trying one thing and another that you don't exactly know "just where you are at."

Enlarging is now done so cheaply that if you wish, your best plate can be made any size wanted. For this purpose they are much superior to films, which are so full of markings and defects that they frequently cannot be enlarged at all.

If a tank for developing is used and directions carefully followed a beginner can do just as well as anyone, this part of the work being almost mechanical. A wooden box coated with asphaltum varnish can be most cheaply made for this purpose; inexpensive text books covering all points can be had from most dealers.

Gas light paper, as it is called, for this size costs only $12\frac{1}{2}$ c per dozen and still cheaper by the gross. Developer can be had in tubes for 5c to 6c, making enough for a large batch.

If moderate care is taken, a lot of work can be done in your leisure moments at a total cost of from only \$1.00 a month up to \$3.00 or \$4.00, which I would consider high.

Nothing I know of will give, for the money spent, as much in amount of time expended and pleasure derived as the hobby of photography.



CUMBERLAND FALLS, KENTUCKY.

NELSON C. D. MARTIN.

HOW TO CONSTRUCT ELECTRIC FLASH LAMP

By OSCAR C. KUEHN



SIMPLE electric flashlight apparatus can be constructed as seen in the accompanying illustration (Figure 1) which I have used with success, and can be made by any one handy with tools at very little expense.

The instrument is for the purpose of igniting flashlight powder by electric current, either by battery or regular house current, through a very fine wire of low resistance, causing a short circuit at the flash-pan in connection with the flash-powder.

The main part of pan is made of a piece of wood 14 in. long, $\frac{3}{8}$ in. thick and $\frac{7}{8}$ in. wide. Any kind of wood can be used; the one I have is made of pine, covered with sheet asbestos, this being glued to the wood on top, sides and ends. Use Le Page's glue, and see that the asbestos is in close contact with the wood—the purpose of this is to make the pan fireproof. Set aside to dry, and in the meantime you can cut and punch holes in two strips of brass for the sides which go on the narrow $\frac{3}{8}$ in. side of the wood. These are cut 14 in. long, $\frac{1}{16}$ in. thick, and $\frac{1}{2}$ in. wide; 8 holes are punched along the edge about $\frac{3}{16}$ in. from the same to allow strips to be tacked to the wood, using small brass headed tacks or screws.

Care should be taken that the ends of the nails or screws on opposite sides do not touch each other, or you will have trouble with a short circuit. Before putting on the strips solder a terminal on each strip about 3 in. from the end for connections. The terminals can be taken from a couple of old dry batteries. Use the ones that are on the zinc, as they have a slot in them that will fit the brass strips. Now tack these strips on the $\frac{3}{8}$ in. side of the wood with the terminals at each end on opposite sides, leaving a $\frac{3}{16}$ in. projection above the top of the wood so as to form an edge to keep the powder in place.

Seven inches from the ends of the brass strips drive a brass



THE DESERTED MILL.

JOHN M. WHITEHEAD.

tack half way in. This is used for attaching a fine wire which acts as a fuse to ignite the powder.

The wire should be No. 33 or No. 36 bright iron such as florists use in stemming flowers. Of course the smaller the wire the lower the resistance. After stretching the wire place underneath flash-cap such as is used in toy pistols. The fine wire heating to the burning point when the connections are made causes instant explosion of the flash powder.

The adjustable holder which is shown under the pan is made of a piece of $\frac{3}{4}$ in. angle iron about 4 in. long. Cut this with a hack-saw to 2 in. from top, and cut away one side of the angle, leaving a flat piece to be bent at right angle. This forms the

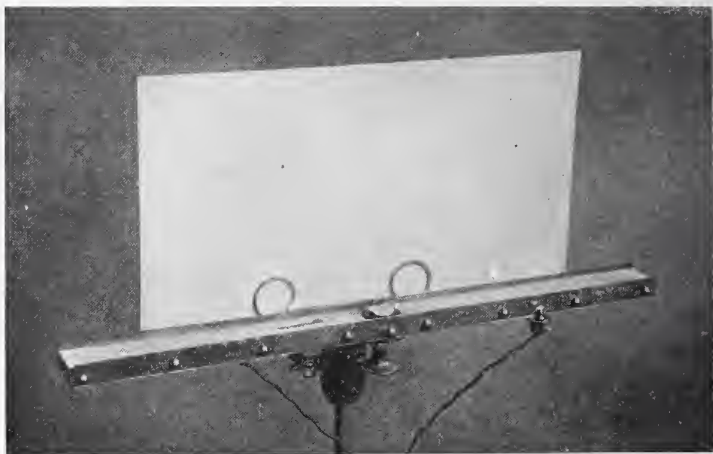

Figure 1.

top of the holder. Drill a hole to take a $\frac{3}{16}$ in. machine screw $\frac{1}{2}$ in. from the end. Fasten the wood pan with a bolt with the head on the top of the pan, using a flat head machine screw about $1\frac{1}{4}$ in. long, and $\frac{3}{16}$ in. diameter. Make this a very snug fit.

The lower half of the angle iron is used to fasten to a music stand. Cut a slot on one side of the angle two inches from the end, $\frac{3}{8}$ in. deep, and full $\frac{3}{16}$ in. wide, and a hole for a $\frac{3}{16}$ in. machine screw on the opposite side in line with the slot. Next secure a $\frac{3}{16}$ in. machine screw about 2 in. long and bend it at right angle $\frac{1}{2}$ in. from the head end. The head can be left



ERNEST MOELLER.

on, as this end engages in the slot, the threaded end goes through the hole, and with a wing-nut it is drawn up forming a clamp on the upright rod of the music stand.

By this arrangement the lamp can be raised or lowered to any height. To wire the lamp about 15 ft. or more flexible lamp cord is used as shown in diagram (Figure 2). Use a pear-push switch to control the circuit. If one does not care to use the battery attach a plug for regular lamp socket. A reflector can be used when not using it in a flash-bag which may be attached by bending a piece of wire as shown in photo to hold card.

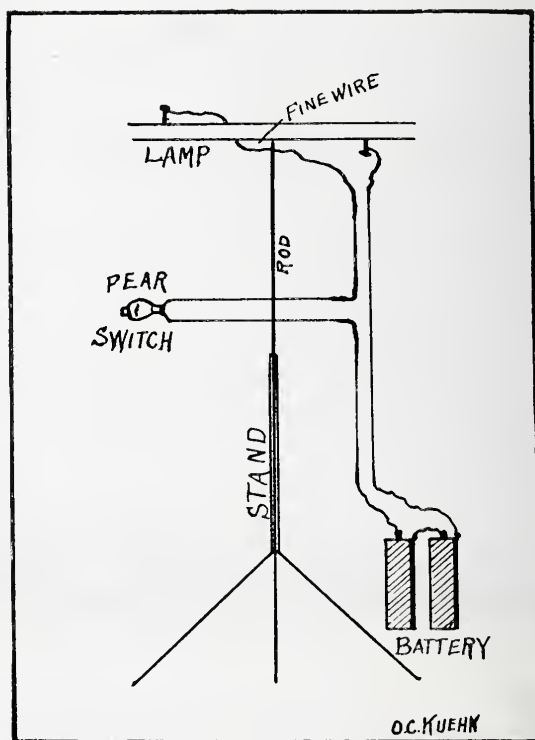

Figure 2.

Illustrating article "How to Construct Electric Flash Lamp,"
by Oscar C. Kuehn.



AT THE WELL, BRITTANY.

STEPHEN H. WILLARD.



Figure 2.

Illustrating article "Business and Pleasure," by Wm. H. Broadwell.

BUSINESS AND PLEASURE

By WM. H. BROADWELL



ALTHOUGH I make a living as a commercial photographer, I do not follow it for that reason alone. It is a hobby with me as well as a business. There is a saying "business before pleasure" which, if followed, leads to success; but "business *and* pleasure" if followed as I interpret it will lead you to success just the same only by a pleasanter route. Make your business a hobby, then you will enjoy doing it and it will not seem like work.

I cover a great many miles during the year because many of my customers are located in other cities, and it is necessary to go to their plants in order to photograph their goods, particularly heavy machinery. Sometimes I am obliged to go to a



Figure 1.
Illustrating article "Business and Pleasure," by Wm. H. Broadwell.

town I have never been to before. In such cases I keep one of my hobbies in mind, i. e., historical places. Always carrying a few extra plates for emergencies, it becomes a simple matter to photograph any old-fashioned house I pass on the road if it looks as though it had a history.

New Jersey is full of buildings of the Revolutionary period, particularly the older and smaller towns. In traveling around with an automobile I often come across such places when I least expect to. If the light is right then I take it, if not, I judge when it will be and try to get it on my way home.



Figure 4.

Again, when going along a country wayside I often see an attractive cluster of wild flowers, a bird's nest, a peculiar geological formation, all hobbies of mine. Sometimes an unusually good landscape. It only takes a few minutes to stop, set up and take any of these views. This is where the pleasure comes in; these are taken for my own enjoyment, yet, at some later time, some one is sure to ask me for a photograph of a wild flower or some other nature subject, then, it's business.

Last year I made a trip by automobile to the Catskill mountains for a little vacation. Of course, I could not resist taking



Figure 3.

Illustrating article "Business and Pleasure," by W'm. H. Broadwell.

my outfit along. This consisted of an 8 x 10, a 5 x 7 and a 4½ x 6 c.c. Ica, 14 lenses and plenty of plates for all sizes. Owing to the September haze I was unable to get the mountain views I expected to and, cutting short my stay, I started home. On the way back I passed through New Paltz, N. Y., quite late in the day and decided to stop over night. My cousin, who made the trip with me, had an old school chum of hers living there whom we looked up. Of course, we had to stay there when they learned we intended staying over night in town.

After supper her husband asked me if I cared to take a walk and see the town. After an hour's walk I was informed I had seen all the sights worth seeing. It was getting quite dark and reaching a cross street it was suggested we return to the house. I asked what lay ahead of us and was told that it was the old part of the town consisting of a lot of old and dilapidated houses not worth seeing. Old houses, I said, what kind? Let us go a little further and see some of them. It was too dark to see very much, but, from what I could see, I asked if he knew the history of them. On our way back I was given the history, and the next morning instead of starting for home at an early hour, I took my 8 x 10 and headed for the old part of the town that "was not worth seeing." Here is what I found. Four Huguenot houses, all with histories. Not worth seeing, why, the two hours I spent there was the best part of my whole trip.

Figure 1. Is a typical Huguenot house. With its long, sloping roof overhung with the branches of nearby trees it is ideal; makes one think of the year 1700, the year it was built. This picture alone repaid me for my trip.

Figure 2. The Abraham Hasbrouck house is not so picturesque, but dates back to 1680. This house has not been modernized since its erection.

Figure 3. The Jean Hasbrouck house, built in 1712, is now used as a memorial building to the old settlers; a monument consisting of a boulder of native rock, partly to be seen in the picture at the right, containing the names of the original settlers is directly in front of this building.

Figure 4. The Du Bois house, sometimes called the Old Fort, was used as a fort, and two port holes are still to be seen in the end facing the street. These port holes are well pre-



FALLS ON WALKKILL RIVER,
NEW PALTZ, N. Y.

WM. H. BROADWELL.

served and now have a piece of glass one inch thick inserted through which a person can see out or in. Of the four houses this is the only one that has been modernized. The piazza being a recent addition.

A couple of views along the Wallkill river near these old houses completed my photographic efforts in the town, and I was ready to start for home, highly gratified that I had something worth preserving.

So, no matter where you go, if you are an enthusiast and keep your hobbies always in mind, you will find something worth while whether on business or pleasure bent.



MAURICE THOMPSON,



C. P. RICE,

A BOX CAMERA WITH AN F. $\frac{3}{5}$ MOTION PICTURE CAMERA LENS

By WALTER W. MOREY

T seems to be the nature of the amateur photographer to never be satisfied with the outfit he possesses, and if he owns a perfectly good outfit of standard make, foreign or domestic, to endeavor to overcome some of the limitations that these have, especially as regards speed compactness or convenience.

Among the members of the Newark Camera Club made up of genuine "name-blown-in-the-bottle" amateurs, there have been several outfits made which have proven very satisfactory to the parties evolving them, among which the one herewith described is a development. (Figure 1). No claim is made for anything exceptional or wonderful. It is simply an assembly of second-hand camera parts with the exception of the lens, the whole however making an outfit which is very efficient and having the advantage of additional speed.

The lens is a three-inch motion picture camera Georz Kino Hypar working at F. $\frac{3}{5}$. This lens is sufficiently fast to take snap shots indoors, about the house and under light conditions generally where the F. $\frac{6}{3}$ and $\frac{4}{5}$ would fail. This lens was mounted in a Tenax shutter, the manufacture of which is discontinued. The writer managed to obtain a broken one, which, on being repaired worked perfectly. It has a range of speeds from $\frac{1}{200}$ to 1 second as well as the usual time and bulb.

This shutter is mounted on a focusing mount as supplied on the Ango focal plane camera, the diaphragm being removed from it to gain a large opening. The shutter flange of the Tenax shutter was turned down in a lathe so that it made a tight fit into the revolving collar of the focusing mount, so that the shutter practically screws into the focusing mount. This mount gives an accurate focusing range of from 18 inches to infinity with the 3 inch lens.



Figure 2.

*Illustrating article "A Box Camera with an F. 3/5 Motion Picture Camera Lens,"
by Walter W. Morey.*

The above described parts were applied to a No. O Premo box camera which takes the $1\frac{3}{4} \times 2\frac{3}{8}$ inch film pack. The box being considerably too long to accommodate the lens, was cut off and a new front put on as shown in the accompanying illustration (Figure 1). A large direct view finder attached to the box completes the outfit.

Outside of the cost of the lens this is the lowest priced practical outfit known to the writer that has all the advantages of speed, compactness and the focusing feature which is very essential in a lens of such large working aperture and focal length.

A few examples of its results accompany this description (Figure 2).

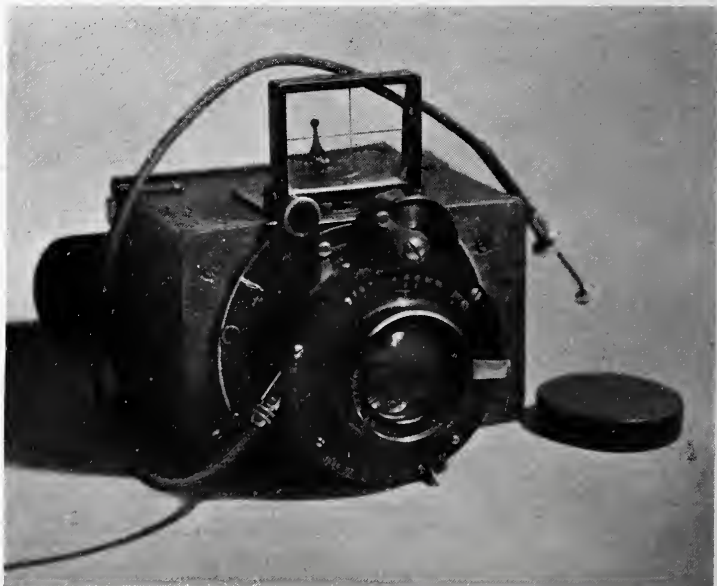

Figure 1.

*Illustrating article "A Box Camera With an F 3/5 Motion Picture Camera Lens,"
by Walter W. Morev.*

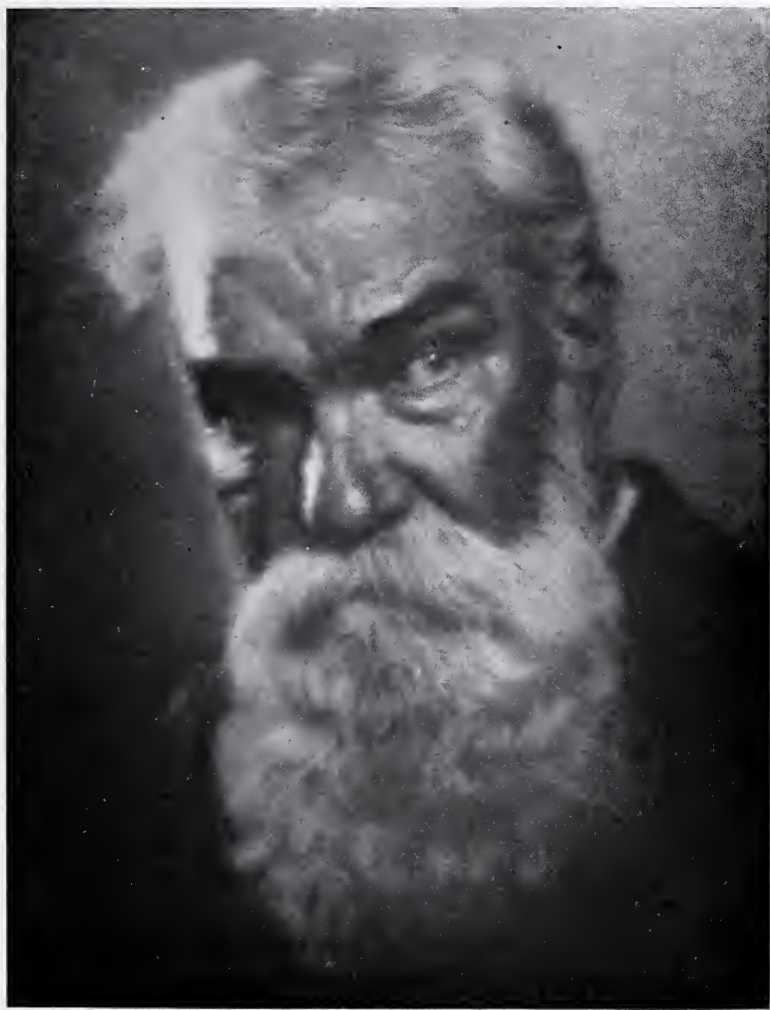

Figure 2.

Illustrating article "The Great Modern Advance in Portraiture," by Henry J. Weber. See page 220.

THE GREAT MODERN ADVANCE IN PORTRAITURE

By HENRY J. WEBER



ANY person alive to the events of the day must have noticed within a very short period the great strides achieved in photography. Taking first of all the cinema, which is of later origin than our other branches of professional photography, and which has advanced more rapidly than any other endeavor within recent years, has at this time arrived at a point of artistic perfection that is wonderful to behold.

The man behind the camera, in conjunction with lighting experts, is producing most wonderful results. Very recently, in fact within the present year, we note the special light control to give those striking character or mirror lightings which help so wonderfully in bringing out character and emotions. The portraitist who would not avail himself or herself of the great opportunity of learning, while at the same time enjoying the cinema shows, is missing one of the greatest lessons of the day.

The next step will bring us to another development of recent years. The schools of photography in different sections of the country and also conventions of professional photographers and amateur clubs, the last not the least in the far reach of education to bring before the public, endeavors of its members and also its idea to educate the public to understand true artistic endeavor by photography. The magazines of later years speak volumes for the amateur, and step by step he advances to the goal of success.

The conventions for professional photographers also is in line of progress, giving all who desire any information desired, and showing all the new appliances needed to produce pictures or portraits. The demonstrations to give actual effects in posing and lighting so that any one may learn the new effects are most beneficial, and these same helps all combined



Figure 1.

Illustrating article "The Great Modern Advance' in Portraiture," by Henry J. Weber.

have and are producing the great upward and onward movement in photography.

We now come to the main theme of portraiture, and in this field the tendency is for the very best, and only within a few years have we noticed the remarkable character renditions by the artists of the country. One big item in this branch we would without hesitation lay to the soft focus lenses, and the balance of honor is indeed to the man behind the lens; for, what good would any lens be if there are no brains to direct its purpose? This instrument in the hands of a careful craftsman is capable of most artistic results, and its results can be seen wherever the best is found.

Large portraits in particular are most suitable for the field of this lens, and to use a sharp focus is to destroy pleasing effects which are easily and quickly produced with the soft focus lens.

In Figure 1 we are illustrating a picture taken ten years ago and showing so many evils that the portraitist is getting away from. The retouching was overdone, destroying all character, and the lighting hard on the forehead. Examine then Figures 2 and 3, portraits taken recently, and a comparison will show how great has been the advance toward something better and truer to the character of the sitter. This, therefore, is the goal of the earnest portraitist—to produce an artistic portrait giving the true character of the person, and that shall please the patron above all other considerations, and to do justice to his or her own artistic feelings.

The lightings produced in many of the portraits today are wonderful, in some instances giving all strength of character, and in others rendering a soft, delicate effect in accordance with the artist's perception as to which effect shall give a well balanced portrait. We are, as it were, only on the threshold of advance, and as to the future?

Success to all earnest portraitists.



Figure 3.

Illustrating article "The Great Modern Advance in Portraiture," by Henry J. Weber.

MANY WAYS OF USING A CAMERA

By JOHN BIESEMAN



HAT one type of camera can be used with the addition of a few adjuncts that are on the market, and thus dispense with a variety of forms and styles, is observed by few; the necessary accessories in developing and printing from the different negatives from each of these cameras, requires and consists of quite a number of items, that in course of time over-crowd our work-room space, and we desire a photographic system that is concentric from the camera to the finished print.

The various ways of using the camera as herein inferred can be applicable to most any camera that one may possess, though the view camera without a casing may apparently be best appropriated for general use. The size for 5 x 7 plates would be as large as we wish to carry on a pedestrian trip. To obtain larger photos this camera can well be used in the enlarging paraphernalia, and produce therewith a large enlargement from a 5 x 7 plate, observing that using a tripod, suitable small diaphragm, and focusing sharply on the screen, will essentially improve such a negative for enlarging. To secure smaller sized negatives, inside kits can be placed in the 5 x 7 holders; such as for $3\frac{1}{4} \times 5\frac{1}{2}$ and 4 x 5 plates, or smaller. A shutter ranging from time and bulb, to 1 and 1/300 second would be preferable; a shutter having 1/100 second for its utmost speed will frequently not arrest motion in running, leaping and diving instances.

A double triple convertible lens, of which each single component renders a different size image, admits of three sizes of images to be taken; adding an auxiliary lens to cap over the doublet, selecting one that will decrease the focal length of the latter, adjusts this camera for taking four sizes of images, viz., doublet, single front, single rear, and the auxiliary placed over the doublet. A scale for the first three focal lengths is at-



CHERRY LANE.

G. W. Harting.

tached on the shutter, while the auxiliary requires a slight decrease of exposure over the doublet, which can quickly be ascertained after a few exposures with it. The latter is very advantageous to use in copying photographs, permitting them to be copied larger than the original, also small objects and articles placed within close range of the lens.

The shutter with lens-board attached is often removable, and can be placed with front to inside of camera, allowing the latter to be ensconced in the focusing cloth a plate holder on each side within, and tied with a string to form a neat packet, over which is placed a shawl strap with handle attached.

To use camera in hand.—A focus scale must be attached. Same can be made for the three focal lengths of lenses by firmly attaching a strip of good paper to the bottom, or track of camera. With indelible, or drawing ink, mark an arrow on the most prominent movable part above the strip; with arrow pointing direct to figures which are marked on strip in exact position as each lens is focused on an object alternately from six feet distance to infinity. A view finder would not be as desirable on camera as a sight finder this little folding device permanently attached on top of, and rear of camera, can be instantly erected, and quickly folded out of the way.

In attaching this device the lens board, if of a side swing or rising and falling pattern, should be set with lens accurately in its center; also the horizontal and vertical swing of camera back, or focus screen be set true to center; place on tripod, and move the latter until a definite small object placed as a mark ten feet from the lens, is centered on the screen; then carefully attach the sight finder in place with sight pointing directly at and a little over the mark. In other words, the sight should point as many inches above the mark as the distance is from center of screen to sight on finder (any neglect in attaching the sight finder, will terminate in the subjects not correctly centered on the plate). To make an exposure on a still or fast moving object, rack the bellows out, so that arrow points to the calculated distance on focus scale; set the shutter, pull slide, hold camera in left hand with back supported against the chest or face, take sight with one eye closed, and press bulb with right hand. One has full control of a moving subject, but must stand parallel with object moving. Slower speed

than $1/50$ second should not be used for still objects; as the lens can be used wide open, and fast plates brought into use as shutter speed necessitates.

A diver descending from a 15 ft. elevation will be correctly arrested in motion at a shutter speed of $1/200$ second. In midday summer sunlight, at $F/7$ or $F/8$; using a graflex plate. $1/300$ second would probably be required where the subject left its starting point with increased speed. The distance from these subjects would not exceed over 25 or 30 ft. It is of important convenience to hold and sight direct to where the subject is to be recorded. Very frequently the focus scale can be disregarded, and the focus cloth fastened on front of camera. Several small slits will let the sight finder through, and the subject focused from the screen in ample time for the exposure. The cloth serves to exclude the bright light from bellows and holder while removing or inserting slide of the latter.

From horizontal to vertical exposures, and all angles between.—A device for tilting the camera upon the tripod must be used. The most convenient mechanism in use seems to be where two boards are hinged together, one to the tripod and the other to the camera; the angle then being obtained by tilting the camera so as the lens points to the desired direction or angle, and then holding all firmly in place by tightening a thumb-screw on each side of this attachment. Many times this can be brought into use when the lensboard will not permit being set at the required angle, nor the tripod permit being placed any farther toward the angular.

Once I successfully photographed the four eggs in a bird's nest that was within 2 ft. of the ground. This was accomplished by raising the rear member of tripod to such an elevation that the lens could be pointed into the nest; the said member being there—while tied firmly to a substantial post of fence near-by; allowing a time exposure with a small stop, and an ortho plate with color filter to be used. A bird's nest and contents of eggs looks most inviting and natural, if lens is set so as to record it as we ordinarily look in the nest with our own eyes. We usually do not look straight down at it, but rather at an angle of little more than 45 degrees, being contented and fascinated to view the greater portion of them, while parts of



A SOUTH AFRICAN LANDSCAPE.

ARTHUR ELLIOTT.

those nearest us remain concealed. As we judge by the dimension of nest interior, we have quickly informed ourselves of their number, and hastily retreat so as to let the rightful owner again take possession of it. Eggs or nestlings should not be photographed during cool weather, as chilling would result, the nest should not be meddled with in the least before birdlets appear; as during nest-building stage and incubation, the parent birds are very sensitive, and easily provoked to abandon their nest, which would conflict with the bird laws, and their protection.

Frequently the parent birds can be exposed for, while brooding their eggs, allowing the camera on tripod to be erected, focused upon them, and an exposure of several seconds or more given. An exposure was thus taken within 3 feet of a wood thrush brooding in shade of wood with a time exposure of 3 seconds, using F/22 stop, for best definition, on an H & D Record plate with bulb in hand.

More frequent the camera can be set up near the nest, which should be focused on the screen, a large stop and fast plate used, and shutter manipulated by means of an attached thread at a distance where one may be concealed from sight. If a brooding bird is chosen, the shutter speed can at times be risked at the longest instantaneous exposure which is 1 second on most shutters; occasionally 2 seconds on a few of them; using a stop and plate to match the time of exposure for a correct timed negative. When exposing for birds feeding their young, or during winter at the window feeding shelves, their motion can often not be arrested, unless 1/50 or 1/100 second is given. The main rule to observe in this branch of work, is to have the camera close enough so as to get the largest image on plate within the focusing limits of the lens, and the largest stop, and fastest plate will need to be used generally. Several exposures will suffice from which to judge after development, whether correct-timed negatives can be attained. If under-exposure results, better lighting may be chosen, or the camera placed farther off, which will give greater action of light on the plate.

A device for releasing shutter at a distance:—Some shutters have a lever release with an eyelet in it, to which a string can readily be attached. Probably more of them subsequent to the



SUN SHOWER.

CLEO. S. BOURGEOIS.

air release contain a push button. To this latter button one should strive to fit a lever cut from soft light wood. This need rarely be more than several inches in length. One end of this should be hinged, or in another manner be attached loosely above the button; the center should rest fairly on it for contact, and the opposite or lower end should have a very small screw eye or staple inserted in it to which the string can be attached. Near this end a long wiry pin should be thrust in the wood lever, and the upper or outside end of wire should be clamped over in such a shape so that a small card can be inserted. This will tilt up and down in unison with the lever when string is pulled, giving notice that shutter has been released.

Now, we do not always expect to fasten this lever to the camera direct; and so the loose or hinged end must be attached to a cleat that wedges in the camera front. The cameras with a movable lensboard will usually admit such a cleat to be placed within the same grooves that the lensboard slides in; it may also be necessary to place a guard wire from the said cleat above the lever to another cleat below the lensboard. This wire serves to guide the lever in its motion down and up, and should lean so close to it so as to permit it to move freely without friction. The writer uses one made in this way, which is neatly constructed, and folds together so it can be placed in an upper vest pocket.

A more direct and concise way of attaching the leverage, so it may be applicable to most all cameras, is to cut four cleats to match in length the sides, and top and bottom of camera front; three hinges can be placed to join them at as many corners, and the fourth or open corner held closed with a small hook or cord. Felt lining can be added on the inside next to camera, and the lever attached to this frame. Other models of cameras will admit a base to be attached to the bed or track, to which a leverage can be fitted. These should always be made to be folded when not in use; and then will be a delightful and serviceable addition to the requisites of the camera. One or several eyelets of staples or screw eyes should be attached to the lever supporting cleats, where string can be guided with least friction so as not to come in contact with any other parts, from the end that is tied to lever, and opposite end in hands of the operator.

The photographing of birds will become an interesting innovation. These have been too long neglected in the past, not only have they been checked in their increase, but cruelly stoned at, dispelling instead of accepting their amiable and friendly approach where they are unharmed and protected, are permanently establishing themselves in the dooryards, gardens, nearby wooded areas and fields. They esteem the society of ourselves for an innate reason; many times the shyest of them will build their nests along paths and streets within the nearest proximity of our passing selves. In our dooryards they will more readily acquaint with us and nest and sing abundantly. For health-inspiring and bright recreative reading, I endorse a year's subscription to *Bird-Lore*.



WAR AND PEACE.

JAMES THOMSON

A SIMPLE HOME-MADE PRINTING MACHINE

By HENRY F. RAESS



HE time saving value of a printing machine is now well recognized. It also allows the photographer to do all his work in the dark-room, doing away with the necessity of going out of the room to make the exposure. He is independent of daylight. Where many prints have to be made, especially from one negative, ease of working and convenience of masking are some of the advantages. Even the non-professional appreciates them, for they are listed by several manufacturers here and abroad for amateur use. The amateur size is usually 5 x 7 in. The larger sizes, 8 x 10 to 11 x 14, are rather high in price, depending upon the mechanical construction. Prices range from about \$25.00 to \$120.00.

The writer constructed one made from various odds and ends usually called junk which had accumulated in the course of years. The machine here described is not intended to compete in rapidity in printing with the elaborate machines on the market, as it is only manually operated, while the more expensive printers often have a foot pedal which operates a hinged board that presses the paper in contact with the negative, and at the same time switches on the lights for the exposure. This leaves the hands free and conduces to quickness in operation.

The body of the apparatus consists of a box obtained from the corner grocer, which once contained 100 one pound packages of sugar. (Figure 1). It measures 19 inches long, 17 inches wide and 14 inches in depth. Four sticks were used for the legs. These may be of any convenient length, according to the height of the user. In this case they were 31 inches long by $\frac{7}{8}$ by $1\frac{3}{4}$ inches in cross section. A piece of wood like this can be bought in almost any lumber yard. They usually are about 12 to 14 feet in length and cost about two cents per foot. These legs were fitted underneath the top and were held in place by driving nails through the sides of the box. Four



THE WAR WIDOW BONNET.

Louis Fleckenstein.

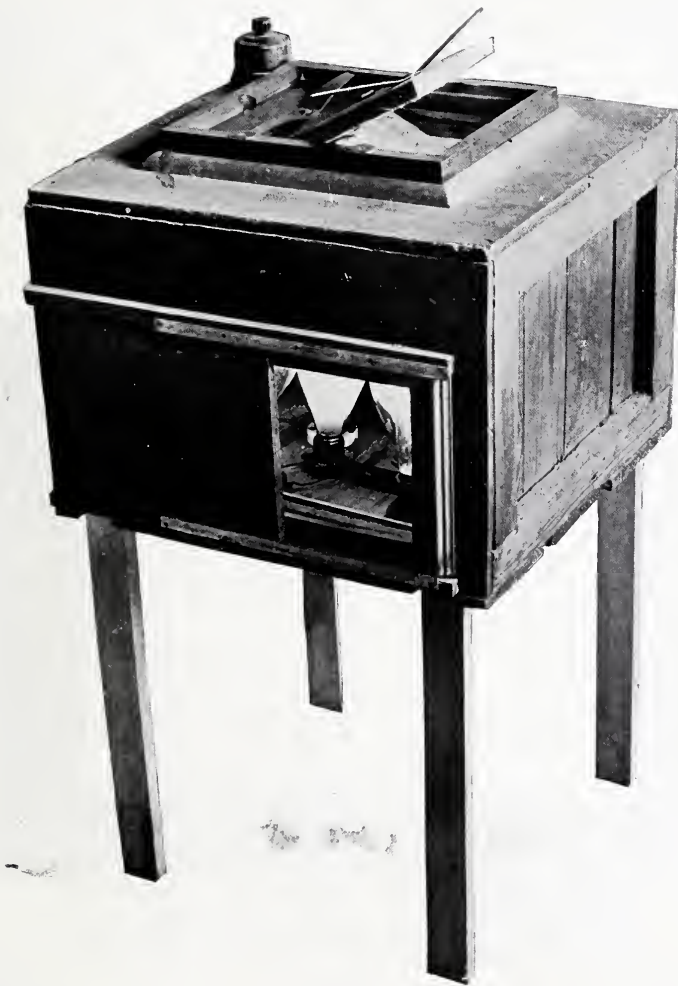

Figure 1.

small holes the size of the sticks were cut in the four corners of the box bottom to allow the sticks to pass through. There are numerous cracks in the sides and especially in the bottom of the box through which a small amount of light leaks, but this has not caused any trouble, so it is not absolutely necessary that the box be light-tight.

Painting the outside is optional with the user. My box was painted with a mixture of water, lamp black, and a small amount of glue to make the lamp black adhere. The mixture was applied rather warm. This formed a very cheap paint and was used more for its esthetic than for any utilitarian purpose. The inner walls were not treated, but a coat of white paint or aluminum bronze would be an improvement, as it would reflect and diffuse the light better. The opening for the printing frame was cut one-half inch smaller than the out-



Figure 2.

side of the printing frame and four pieces of $\frac{3}{4}$ inch quarter round with mitered ends were nailed around the printing frame. This formed a frame which kept the printing frame in proper place while making the exposure. The quarter round can be obtained in the lumber yards as mentioned above and costs about the same as the plain sticks. In order to use smaller printing frames also, a kit was made from a piece of half-inch board the same size as the outside of the large printing frame. In this an opening was cut like that in the top of the printing machine and here again four pieces of quarter

round were nailed to hold the smaller frame (Figure 2). This board takes the place of the large printing frame and allows one to use the smaller frames. Four notches filed in the center of the quarter round with a round or half-round file facilitates the removal of the frames, as it gives the fingers a better opportunity to grasp the frame. There is sufficient room on top of the box to cut a hole for a 11 x 14 frame, but the writer fitted it for an 8 x 10 and with a sheet of glass. It will, of course,



Figure 3.

accommodate $6\frac{1}{2} \times 8\frac{1}{2}$ negatives and the kit holds a 5×8 frame. This takes one 5×7 , or one or two 4×5 negatives.

Underneath the printing frame opening is pinned with thumb tacks a sheet of tracing cloth, but tissue paper could be used. This is to diffuse the light. To print from an uneven negative, pieces or strips of tissue paper are placed on this tracing cloth to control the light in different parts of the negative. The sliding door at the side gives access to the lamps and can be used if

necessary for printing very dense portions of a negative. The door was made by cutting a square hole in the side of the box, nailing three strips of wood just back of the edges, and nailing two strips of sheet metal to the upper and lower strips to hold in place the piece of board used as a sliding door.

The keyless sockets are screwed to a piece of board and sufficient lamp cord used to allow for convenient removal of the board from the interior of the box when necessary (Figure 3). The number of lights and their candle power is of course optional with the user. In the writer's case there are four 100 watt nitrogen lamps, one in each corner and two 60 watt tungstens in the center and an 8 candle power ruby for a pilot light. In the absence of a ruby light a two candle power lamp may be used if covered with ruby or orange cloth. The pilot light is so connected with the printing machine switch that it is always burning when the current is turned on at the main switch. The lamp sockets are wired in multiple. If this part is not understood by the photographer the board and sockets should be taken to an electrician for wiring. The writer being right-handed the switch was placed at the top of the box at the upper right-hand corner.



A MISTY MORNING.

WILFRED HICKMAN.

REFLECTIONS IN PHOTOGRAPHS

By A. LOCKETT



REFLECTIONS, of the right kind and in their proper place, are among the most beautiful of natural phenomena, and the photographer has, here at least, a decided advantage over his imaginative brother artists of brush and pencil, in the fact that his pictures will be scrupulously truthful—unless, indeed, he chooses to introduce handwork. The common idea, for instance, that reflections in water afford an exact but reversed copy of the subject above is very far from accurate. As will presently be explained, sometimes more may be visible in the reflection than in the original, sometimes less, while the relative arrangement of different parts will often be altogether altered. This depends on quite definite laws, ignorance or neglect of which has occasionally led even celebrated painters into producing demonstrably impossible and absurd effects, whereas the study of a photograph showing the same subject would probably have saved them. Unpalatable as the saying may be to a certain school, Hamlet was undoubtedly right in insisting that the end of Art, whether in photography or the drama, is “to hold, as ’twere, the mirror up to Nature.”

Reflections in water, be it river, lake, or sea, are almost invariably pleasing. The most faithful image is obviously furnished by still water; but, generally speaking, a slight agitation of the surface, by ripples or waves, produces results of greater picturesqueness. The first gives virtually a dead picture; the second suggests some sort of life and movement. Subjects showing water in motion call for a good light and rapid exposures; while a medium stop is recommended, so that the characteristic wavering outlines may be well defined. A small stop, however, is a mistake, as it tends to destroy atmosphere and distance. Backed plates yield decidedly the

best results. The illustration, "Cleopatra's Needle," is fairly typical of this class of subject, the view being taken from a landing-stage on the Victoria Embankment, London. It may be of interest to state that the base and steps of this celebrated early-Egyptian obelisk were badly chipped and pitted during one of the recent air-raids, but are to be left with their "scars of glory" untouched, as an historical memento. If the writer is not mistaken, New York possesses a companion obelisk, in Central Park.

A most important rule to be followed in selecting such subjects is either to study them from exactly the same stand-

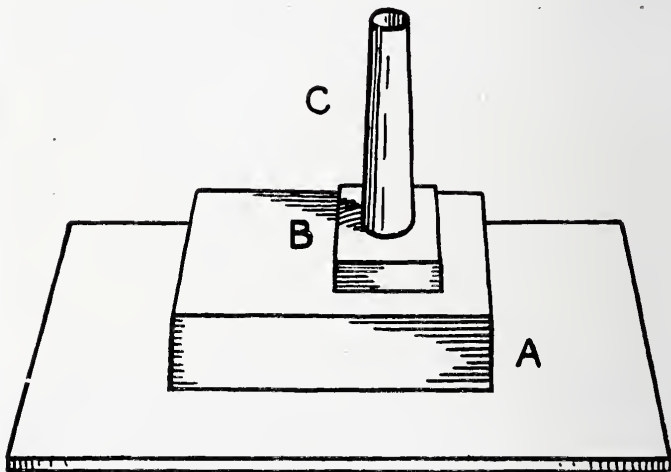

Figure 1.

point as the lens, or else to judge them from the image on the focusing screen. Unless one or other of these precautions is taken, it may easily happen that the "broken reflection" so much admired by the observer is not recorded in the photograph at all, or that, at best, a far less pleasing arrangement is presented. The reason for this is that the amount reflected differs greatly according to the position of the eye, or of the lens, and if the two are not made to agree the results must inevitably be dissimilar.

A piece of looking-glass, say, about 12 ins. by 10 ins., will help to explain the matter. Lay it flat on a table and obtain



CLEOPATRA'S NEEDLE.

Illustrating article "Reflections in Photographs," by A. Lockett.

several simple objects which can be combined together to simulate some architectural or natural feature. Thus, in Figure 1, A is a rectangular box, B a smaller one, and C a tapering cylinder of paper, pinned or pasted at the join. When these are stood one above the other as indicated, they resemble, with a little stretch of fancy, a pier-end and lighthouse.

Now, if we place the eye very near the objects and a trifle above the top of the supposed lighthouse, there will be no reflection visible at all, as shown in Figure 1. If, still keeping the eye at the same distance, we gradually lower it,

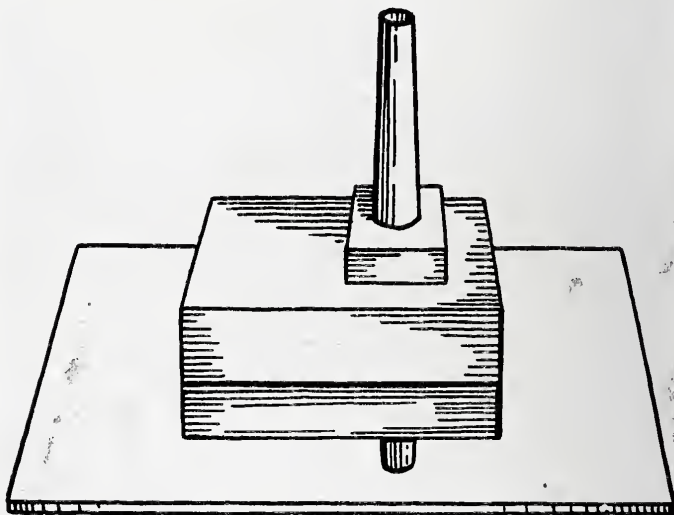

Figure 2.

the result is slightly improved, as in Figure 2. The lower box, representing the pier-head, is now reflected, and just the top of the lighthouse, but no more. Evidently, other things being equal, a lower standpoint gives more reflection than a high one.

To get a yet better result, we must move the eye further away, though still retaining it at the previous level, when at a certain distance the whole subject will be seen reflected, as in Figure 3.

A number of experiments like this, with different combinations of objects, will be very instructive, and will enable the



RAINY DAY REFLECTIONS.

Illustrating article "Reflections in Photographs," by A. Lockett.

worker to see how greatly the amount of reflection varies according to the distance of the reflected object from the water's edge, the distance of the eye from the whole subject, and the height of the observer. Inasmuch as, in a photograph, the lens takes the place of the eye, it is clear that the height and distance of the camera must coincide with the position of the observer, if correct results are to be expected.

The subject may, indeed, be worked out geometrically, when.

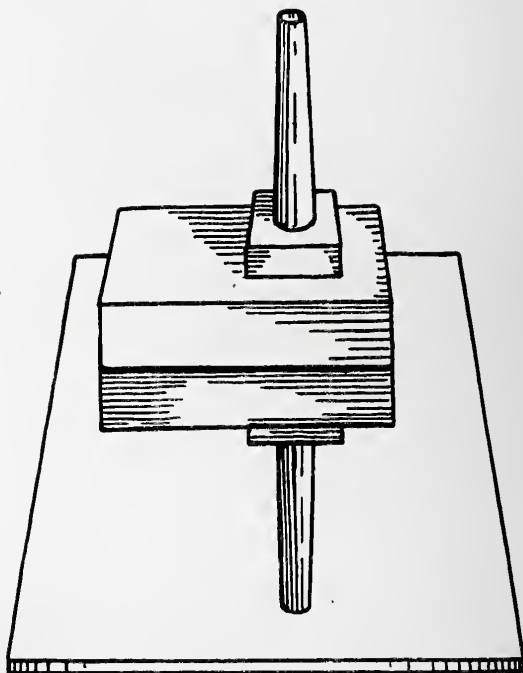

Figure 3.

given a plan and elevation and the position of the eye, the exact amount and place of the reflections can be accurately plotted out in anticipation. This, however, belongs to geometrical perspective, and will be found dealt with in textbooks on drawing. It is a useful study for photographers who may occasionally need to insert reflections by handwork on the negative or print.

It is not sufficiently appreciated how great an improvement



WET WEATHER IN LINCOLN'S INN FIELDS.

Illustrating article "Reflections in Photographs," by A. Lockett.

may be wrought in an otherwise rather commonplace composition by tremulous reflected outlines. There are some streets and buildings that will never make a pleasing photograph normally, but which become completely transfigured after a brisk shower of rain, or even a liberal watering of the road. This is worth remembering, not only by the picture-lover but the commercial worker. For example, a well-known camerist of the latter denomination tells, with inward self-approval, the story of an enterprising house-agent who was led to see how far more interesting and desirable an otherwise cramped villa, in a dull, dusty thoroughfare, could be caused to appear when depicted with long trailing reflections beneath, and a pearly shimmer on the roof and other parts that caught the light. It somehow gave the impression of added size and space, and one instinctively drew the fallacious but sale-inducing conclusion, "if this retreat looks so attractive on a pouring wet day, what must it be on a fine one?"

There are "faked" rain scenes, besides the genuine variety. The assertion may surprise some and disgust others; but, after all, if the highest aim of Art is self-concealment, what does it really matter how the result is attained, so long as it is good and no unfair advantage is taken? By way of an exercise in discrimination, two typical photographs are here reproduced, "Rainy Day Reflections" and "Wet Weather in Lincoln's Inn Fields". One of these is practically a "straight" picture, while the other was really taken on a fine dry morning, and owes its deceptive dampness entirely to brushwork and "knifing" on the print. When readers of this article have sufficiently puzzled themselves, or have contentedly made their minds up, they may obtain satisfaction as to which is which by referring to a note at the end.*

A few details regarding the method of "faking" will, perhaps, not be unacceptable. In the first place, a duplicate bromide print is necessary as a guide. A black "bromide pencil" and a piece of white crayon are used at this preliminary stage; while genuine photographs of somewhat similar subjects with reflections, as well as engravings, etc., will be of service as models. Having broadly sketched in the effect desired, it may be imitated in more finished style on what is to be the



NEAR OLD VAUXHALL.

Illustrating article "Reflections in Photographs," by A. Lockett.

final print. Water-colour should be mixed to exactly match this (for crayon betrays itself too much), a slight trace of gum being added if there is any shininess of surface. A fine-pointed sable brush is best, and it is advisable to use it with a minimum of colour, obtaining the requisite effect gradually and cautiously. This does not mean that parts can be gone over again, which is to be avoided if possible, but that only a small surface should be dealt with at a time. It is most important that the handwork should be undistinguishable, when dry, from the photographic image. For introducing lights, a surgical scapel, kept sharp on an oilstone without oil, is useful, or else one of the nib print-trimmers made for insertion in a pen-holder. The writer, however, prefers an ordinary pen-nib with half the split part broken off, so as to leave but one pointed piece, which is sharpened at either side on the stone. This gives a remarkably keen edge, which may be used with a gentle scraping action, producing lights that will bear very close examination without betraying their origin.

It is not always realized what a difference is made in capacity for reflection by the presence in water of suspended solid particles, such as fine sand, clay, mud, and the like. The less clear the water is, the less will become its power of mirroring adjacent objects; but, at the same time, it is better able to receive cast shadows. There has often been a confusion between these two things, reflections and shadows, which are, of course, entirely distinct. Town-dwellers by the side of a muddy river must not expect to see such bright and delicately-detailed images inverted below the banks, as would be viewed in a more pellucid stream; but, under suitable lighting conditions, the long-cast shadows on the surface of the turbid water may offer an almost equally effective substitute.

Night reflections stand in a category by themselves. The wavy, serpentine gleam of lamps on wet roads, or beneath bridges, embankments, seaside parades, etc., is singularly pleasing. With still water, moist sand, or in a lonely street after rain, long exposures may be given, using a rigid tripod; but with moving or rippling water an artificial method is the only one possible. Thus, the illustration entitled "Near Old Vauxhall"—a make-believe moonlight scene—was really taken in sunshine. The negative was treated locally with ammonium

persulphate to introduce dark clouds and their reflections; while the lamps and their imaged trail were partly pencilled in on the negative, and are partly due to knife-work on the print, which, obviously, is an extra-deep one.

An old bone of contention is whether a-reflected light can ever be brighter than its source. In theory it cannot; but, in strict fact, it often happens that the reflection may be visible when the most intense part of the source is hidden. For example, the sun may be shining above a wet pavement, while the major portion of its disc is concealed from the observer by a light-tipped cloud. In such a case, the reflections from the sky will undoubtedly be much brighter than their apparent origin, and the same thing may occur in other circumstances. Thus, it is quite common for the eye to see reflections of objects which are not themselves in sight.

From considerations of space, only water has been dealt with as a reflecting surface, but many others will readily occur to mind. Polished marble in architectural interiors, the well-waxed top of an oak table, imaging whatever is placed on it, burnished metal, glass, etc., are all capable of yielding pleasing results. Care must, of course, be taken to ensure that the desired objects alone are reflected, while others not wanted in the picture are kept out of sight, or screened off.

**Note.*—The print entitled "Wet Weather in Lincoln's Inn Fields" is the "faked" one.



ROCKLAND HARBOR, MAINE.

JOHN MARDON.

ARE YOU A C. C. M.?

The Personal Experience of One

By RABAMAT



HIS title may seem like a twenty-third lodge degree or an abbreviation for special services rendered Uncle Sam, but it stands for *camera club member*.

I bought my first camera in the days of the original so-called "Pocket Kodak," a little brother to the present "Brownie"—small at that time as cameras went, but entirely too large to put into any respectable pocket. This was before the day Dr. Goodwin invented the roll film. I snapped everything I could—not getting many negatives because the capacity of my camera was one plate, which had to be loaded into a slot in the back of the camera.

You ask here—what results did I get? Well—counting the few good negatives (they all would have been good but for some little thing such as over- or under-exposure, light struck, insufficient washing, scratched or frilled emulsion, etc.) I find I generally got what I took; could get my subject right side up on the plate, and when it came to landscapes I was also there with a good collection of telegraph poles, abundance of foreground and bald-headed sky. Of course, certain snaps which would have been prized highly did not turn out as contemplated—I refer to the taking of some close-ups of horse and bicycle races. Fine fishing scenes and marine views were lost because the boat on which I was a passenger rocked my stomach out of focus. After several years with this camera companion and having nearly worn off the shutter "button" by my continual pushing, I eased up for a long rest. When I got my second wind I purchased a collapsible Kodak with roll film.

One day I met an old school chum who was an out and out camera "nut," and we living in a village that boasted of enough inhabitants to permit a fellow to stay out after 8 P. M. without being called a regular devil, he persuaded me



Theodore Eitel.

to join a local camera club. I say persuaded me—rather he relieved me of the cash for three months' dues in advance and filled out the application. I was duly elected, and when I attended the first meeting I took with me several prints as evidence that I was a regular photographer. Some of the members glanced over the prints with a bored look, and other members happened to be too busy with their photographic work to look at them. When I strolled into the club's exhibition room and saw the fine work, pictures of all kinds hanging on the walls, I then comprehended my knowledge of photography was what they had long forgotten, but then and there I made a vow that I would eventually pull myself up on more even terms.

I entered a competition being run by a photographic magazine for the best pictures taken with a camera costing under \$10 and I won a prize—third, the last one. Naturally I felt that everybody in town knew of my success, or if they did not, they should have known. After several more weeks I entered our club's annual print competition and won—a place on the wall; one of the competition rules being that all prints submitted would be hung.

That was only about five years ago. Since that time I have won several of our club medals and honorable mentions, also medals, cups and diplomas of other clubs and exhibits.

I can now hear you saying, "great Scott, listen to that fellow blow his horn." Wait a moment; I have cause to blow it. Why—because I am a C. C. M., one of thousands of good sports who make photography their hobby, take and make prints for their artistic and pictorial qualities. I am proud to be a C. C. M., and especially so as a member of our club, the oldest in the country. My suggestion is if you want to get out of your hobby all there is in it, become a C. C. M., work, rub elbows with the other members, learn what they know, read the photographic magazines and textbooks, and when you are one of the advanced workers, show the new member who started where you did what to do and how to do it. There is prestige in being a C. C. M. no matter where your home town may be located. If there is no club in your city, join one nearest you even if you can only attend occasionally. If that is not possible, organize a club.

Our formula for a good camera club—and by the way, the experimental part was started by our charter members in 1888—is good fellowship, something doing all the time and visitors always welcome. We have the best of equipment for printing, enlarging, developing, lantern-slide making, studio for portraiture, various lenses, etc. Bi-monthly business meetings afford members an opportunity to get together, and twice a month we hold lantern-slide exhibitions, the work of other clubs as well as our own being shown, after which we gather around our mess table and partake of home-made “chow.” Members only are allowed to drop a few cents in the “kitty” to pay the cost of the “chow.”

Our officers, board of trustees and various committees are live ones; we have our winter and summer photographic outings, lectures and demonstrations on different subjects, annual competitions for prints and lantern slides, special competitions and “Ladies’ Nights” in which the fair sex are well represented. So that beginners cannot be neglected. If they desire to learn, we have an educational department, a committee composed of some of our advanced workers who personally instruct the new ones in all branches of photography.

Now you are getting interested and want to ask what are the dues. Why, man, the monthly dues wouldn’t set you back the price of a good new necktie, even at pre-war price. You also are wondering where such a club is located and its name. Personally, I think it is too good to keep you guessing and will let you in on it: Newark (N. J.) Camera Club.

When you are out our way, drop in—we never close and *Welcome* is woven in the door-mat. We can then explain the other fifty-seven reasons why you should join.



SILENT SENTINELS.

IRVING S. LOVEGROVE.

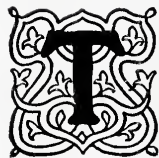

Figure 1.

Illustrating article "Seashore Photography," by A. M. Sutton, M.D.

SEASHORE PHOTOGRAPHY

By A. M. SUTTON, M.D.



THESE lines are written more particularly for the every day amateur who has an ordinary vacation equipment, but neither the time nor, perhaps, the inclination to go in seriously for marine work as a specialty. Most of us like to look at a decent wave picture, however, and we all are attracted by the work of the master artists in this line.

As far as the ordinary beach snapshot is concerned, we may dismiss the subject by saying that usually everything is in the photographer's favor, and the pure snapshotter will score more nice clear prints on the beach than anywhere else, perhaps. It is when we wish to make more or less artistic pictures of the sea itself in its varying moods, that some few pointers will come in useful.

Practically all sea pictures are of necessity snapshots; a slow form of speed work. A high speed shutter is neither necessary nor desirable; the ordinary kodak shutter used at the speed marked $1/100$ or $1/50$, which is actually about $1/40$ sec., will be found most suitable in the majority of cases. If

you have a really high speed shutter, don't use the fastest speeds unless the rushing water is very near the camera: the object is not to "freeze" the water, but only to stop motion sufficiently to prevent obvious blurring, still leaving the suggestion of motion, which adds much to the effectiveness of the picture. So the matter of shutter speed is soon disposed of.

Generally in semi-instantaneous work, our limitations and our handicap are felt in the direction of lack of sufficient light; the difficulty most often is to avoid under-exposure with the largest stop at our command. In marine work, on the contrary, over-exposure spoils more films than the opposite condition;



Figure 2.

a stop as large as $F/8$ will rarely be used on the shore, except on a dark rainy day, or about sunset on a midwinter evening. But if your equipment does not include something smaller than $F/22$ you will often be handicapped by excess of light under conditions which are frequent enough in summer. Most of us get our vacation in midsummer, too, at the very worst time for making good sea pictures. However, even midsummer days have morning and evening light, which is far preferable for the purpose to the merciless glare of midday. If you must make sea pictures in summertime, do it before 9 a. m. or after 4.30 p. m., and you will be better satisfied with your results.

The difficulty is to avoid flatness in the negative and to secure the normal contrasts; to get the foam on a curling wave really white and sparkling, not gray, as it will be if over-exposure is present. That is the idea in cutting down the exposure, or rather the amount of light admitted during exposure. Try a few experiments with small apertures under what you would consider inland unfavorable conditions: say, on a sunny December afternoon, try $1/25$ sec. at F32 on a fairly open sea piece. Don't have a mass of black rock in the near foreground, and expect to get shadow detail in it, but it may surprise you to find how well rocks forty or fifty feet away are lighted, even by the winter sun, and the mass of reflected



Figure 3.

light from the sea. If you can't get to the sea in winter, try the same thing in the waning light of approaching evening in summer. Simply as an object lesson in exposure, my first illustration (Figure 1) shows how small an amount of the intensely actinic light of the seashore is needed to make a printable impression on the sensitive film. This negative was made on pack film with a needle-hole in place of a lens. Data as follows:— diameter of needle-hole, 0.4 mm., about $1/60$ in.; distance, between needle-hole and film, $3\frac{1}{2}$ in.; exposure, $1/10$ sec. at 11 a. m. in September, sun shining.

A little calculation will show that if a lens had been used, the stop corresponding to the aperture of the needle-hole would have been about F210. My object is, of course, not to advo-

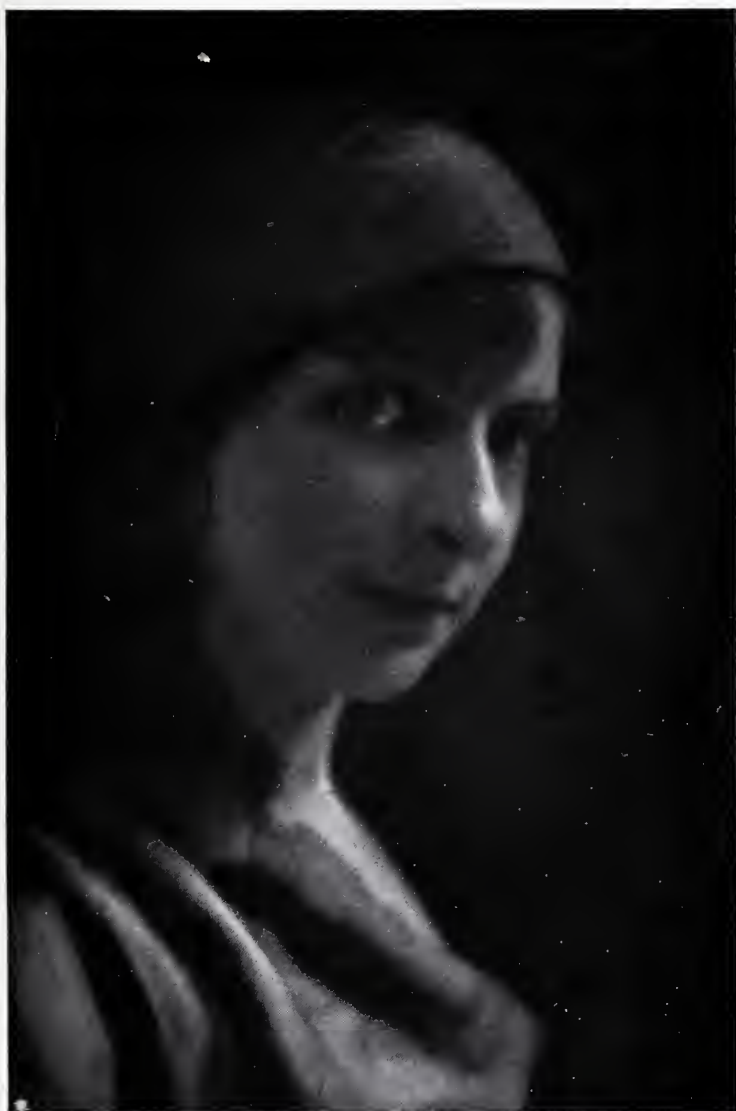

R. B. M. TAYLOR.

cate the use of any stop as small as this; but to demonstrate how easy it must be to over-expose with the stops in ordinary use upon subjects of this nature, in which the minimum exposure necessary is so extremely small. The proposition I wish to establish is that in sea pictures it is usually much easier to over-expose than the contrary; and that the least exposure necessary to bring out the required detail will invariably produce the best results. In other words, I would reverse the time honored maxim for sea pictures, and say, "Expose for the high lights, and let the shadows take care of themselves."

When using a meter or exposure table, which is always advisable, to gauge the actinic power of the light, at the time,



Figure 4.

I have generally found it correct to give from $\frac{1}{8}$ to $\frac{1}{10}$ of the indicated exposure.

For choice of lighting in wave pictures, I prefer to have the sun across, or nearly ahead, and of course some form of sky shade is a necessity. Whatever the position of the sun, it is well to protect the lens from the strong diffused light, even if there is no chance of direct sunlight striking its opening. More or less general fog is apt to result from neglect of this precaution, as the sky and water are themselves practically sources of light, and pretty strong light at that.

The choice of a view point will of course vary with the conditions present at the time: two cardinal points should always



HOMeward.

James E. Paton.

receive attention. First, the camera should be held low down, not more, as a rule, than 24 to 30 inches above the sand; and second, it should generally be pointed at a more or less acute angle to the line of the advancing waves. Get as near to your wave as you can, even at the risk of a wetting; a good wave picture is worth it, and frequently you will pay the price. While waiting for the wave you want, keep the lens turned away from the wind, and as much in the shelter of the body as possible, to avoid the lens becoming fogged by the fine spray which is always in evidence. The sky shade is quite a help in this way, too.

A tripod is a very useful accessory; not because time exposures are necessary, but because often one has to wait sometimes quite a while for the desired effect. If the camera is set up on a tripod, not fully extended so as to keep the lens low down, and the view carefully lined up and its limits defined in the finder, one can then watch the scene itself for the psychological moment, without having to look constantly in the finder to see if the camera is correctly pointed, horizon not tilted, and so forth. And without a tripod one has often to wait in a crouching, cramped position for the right wave to come along, which is not conducive to holding the camera steady, and makes one too impatient.

My favorite procedure is to watch the sea for a while, and move about a little, while deciding just what I want to get, and from what view point I may best secure it. Then I set up the camera on the shortened tripod, and proceed to get the desired point fairly central in the finder, with the horizon level and the proper adjustment of sky and foreground. It is well to fix the tripod legs firmly in the sand, as there is generally more or less breeze blowing. Then I squat so that my line of sight is as nearly as possible on a level with the lens, and wait for the effect I want, keeping a cap on the lens until just before I think it's going to happen. Of course I keep my weather eye open, prepared to retreat strategically a few paces when the wash from a wave comes a little too high, leaving the camera where it stands; and equally prepared to grab the whole thing up by the roots and scoot for it if the occasion seems to call for radical measures. I always expose upon what I see in front of me, not from the finder.

In rock work a tripod is often not practicable; then I try to get a comfortable position with something to lean against, and bringing the carrying case round to the front, make a steady-rest for the camera out of it, the weight being taken by the strap round my neck. In this way the camera can be held very steady in one position for some time without fatigue.

In photographing a curling wave, or one breaking against rocks, press the release just as the wave starts to curl or while the spray is still rising; be a little previous or you will be too late. Above all, especially in rock work, keep cool and don't get excited; otherwise you will surely jar the camera at the



Figure 5.

moment of exposure, and spoil your picture. It isn't always easy to remain impassive while a huge comber thunders in upon the rocks a very few feet from your sheltered position, and the spray flies high.

In my experience, the best conditions for wave photography are found on a clear fairly calm day in winter, with a heavy ground swell running, as is frequently the case at that time of year. A few light clouds near the horizon, for choice, and the less wind the better. On this coast, Central California, I have noticed that the big waves come in groups of three or four at intervals of twelve to fifteen minutes; the first wave turns the foreground into a seething mass of white foam, and often

hides undesirable black rocks; the second adds to the turmoil, and usually the third is the wave to get, just as it curls in majesty, or bursts in thunder on the cliff. The best waves are generally to be seen around high tide, or an hour or so before or after.

The photography of real storm waves is another story, and is generally beyond the reach of the amateur with his regular equipment. A waterproof camera, full suit of oilskins and rubber boots, a strong life line and a trusty assistant to hold it, are as necessary as a good brand of physical courage, and the skill only to be acquired by long experience. Besides, unless one lives at the seashore, it is rarely one's fortune to witness a



Figure 6.

really rough sea. And if perchance a storm does come along, the wind is so rough, and the air so full of flying spray and spume, and any near approach to the sea so difficult and dangerous, that the average amateur is rather out of it. No. 71 of the Photo-Miniature, now out of print but still sometimes procurable in out of the way places, contains two fine articles on the photography of storm waves by two past masters in the art, F. J. Mortimer and Jas. H. McCorkle, which are well worth studying.

Use only fresh film at the seaside, and develop your exposures as early as possible after the roll is finished. Furthermore, especially after an evening expedition, it is wise to open

the camera front, pull out the bellows, and stand it on a shelf inside the house for the night, to allow any moisture absorbed by the leather to dry out. Rub the bright parts over now and then with a rag slightly moist with oil. If the camera gets splashed with sea water, as will happen, stop right there and wipe it as dry as possible, and when you get home don't forget to open it up to dry as described above.

Now as to my illustrations: excepting No. 1, which has been mentioned above, all the negatives were made with an old style No. 3 F. P. K., with B. & L. Plastigmat lens, on roll film, mostly Vulcan. Developed with Thermo Pyro Soda in tank. The time of day is in all cases reduced to true solar time,



Figure 7.

regardless of "daylight saving," so the standard is uniform, summer and winter alike.

No. 2, "Sunset," like the needle-hole, was made with the idea of showing what is possible in the yellow light of the setting sun by the seashore. It will be noticed that the direct rays of weak sunshine were not enough to cause fog or halation, and yet the scene is sufficiently well lighted for a snapshot. Data: 7.25 p. m. in June, F/6.8, 1/25 sec. No filter.

No. 3, "A Pacific Comber," was made in August at 4.45 p. m., weather dull and cloudy. F/6.8, 1/25 sec. This shows the advantage of keeping the camera low down: it was on the unextended tripod, placed close to the edge of the surf.

No. 4, "Where the Surges Ever Roar," on a cloudless day in mid-December, with the sun nearly ahead. F/32, 1/40 sec.



O. C. CONKLING.

Nos. 5 and 6, "Sunshine on the Breakers," and "The Fountains of the Deep," were made on the same day, between 1 and 2 p. m. on Jan. 1st, with the sun well ahead. F/32, 1/40 sec. Taken while standing in the surf in a bathing suit.

No. 7, "A Long Roller." A winter evening, dark and stormy, in Santa Cruz Bay, California. 4.15 p. m., F/6.8, 1/25 sec. One of the longest curling rollers I ever saw; it extended considerably to the left of the limits of the print.

No. 8, "The Restless Sea," Sept. 3 p. m., sunshine, horizon cloudy, F/32, 1/25 sec.

Perhaps I should have specified that the automatic shutter on my kodak had been recently overhauled and tested, the report of the test being that the two highest speeds marked 1/100 and 1/50 were both actually 1/40, and the other speeds approximately as marked.

It will be noticed that in the prints I have chosen for illustrating this epistle, I have not attempted anything out of the ordinary; just common everyday subjects which with average luck are available to any one in the course of an ordinary seaside vacation. Of course they represent the expenditure of quite a little time, patience, and study, and I would hate to say how many spoiled films. But to me they are worth while, and some of them have pleased others, too. And if any of them are good enough to incite some of my readers to try for themselves, my objective will be attained.



Figure 8.

Illustrating article "Seashore Photography," by A. M. Sutton, M. D.



Copyright by ERNEST L. CRANDALL.

DIRECT PHOTOGRAPHY WITHOUT USING THE COPYING LENS

By CHEEVER C. CONLEE



THE accompanying illustration was made from an ordinary print without resorting to the camera.

The operation is very simple, indeed, and while the results are necessarily crude, from an artistic standpoint, it is the opinion of the originator that the process can be improved on to a very large extent.

The subject illustrated is a retouched portrait. If using a common lithographed commercial postcard, such as can be purchased anywhere, I place the same in a tray of warm water for a few minutes, then lay the card face down on a sheet of glass, and remove two layers of the card. After thoroughly clearing the surface of the card from all lint and particles of paper, I apply a transparent solution, procurable from any dealer in art supplies, and which is used in making tracing paper. It is very reasonable, and a half pint will render transparent a great many subjects.

After thoroughly drying the original, I place the same in a printing frame and make the negative. I have had the best results with Aristo Platino paper, though I suppose good results may be obtained with any other kind. If the original is contrasty and sharp, I do not strip the negative for the final printing, but if not so, it is advisable to do so, stripping down to the film by the same process used in preparing the original for the first print.

Retouching and blocking out on the resultant paper negative is very easy, as the paper holds the retouching medium without having to resort to varnish.

I have had very good success in enlarging from these paper negatives, and it has proven to be a very easy process in making a hurry print.



PRINT FROM PAPER NEGATIVE.



PAPER NEGATIVE.



ORIGINAL.

Illustrating article "Direct Photography Without Using the Copying Lens," by Clarence C. Conlee.



A BRIDGE.

WM. E. ZIEGENFUSS, M.D.

THE PURSUIT OF AN IDEAL IN THE GREAT OUT DOORS

By WM. E. ZIEGENFUSS, M.D.

A GOOD many years ago my brother-in-law visited me in northern Michigan and brought with him a mysterious wooden box. It proved to be a new "Hawkeye" camera equipped with a single lens, as I now know, but it deeply excited my curiosity and interest.

The pictures secured were rather crude, but I still have them in an album and prize them highly as records of a pleasant few weeks' visit.

The all-seeing eye of the wonder-box stirred my system to fever heat which has not to this day been cured. It has not, however, proved lethal to anything outside the coin of the realm. The disease was somewhat alleviated by the purchase of a black box—4 x 5 Premier—which seemed best to answer my purpose at that time. I had it fitted with a rectigraphic lens. The outfit gave me much pleasure, and has introduced me to my



EDWIN LOKER.

present three cameras all fitted with the anastigmatic lenses of our day.

My early experiences without a teacher ran about parallel with those of other early amateurs and need not be recounted here. But out of that experience came a wonderful fund of useful and pleasurable knowledge of the beauties of nature and the delights of picture hunting. These hunts not only enlarge one's mental vision, but they add vitality to the physical well being of those who practice them.

To get the best out of these picture rambles it is necessary to follow some sort of system—have an ideal. A somewhat extensive experience with the "species" has forcibly brought to mind the habit of desultory "snap shooting" indulged in by nearly all amateurs. They have no ideal to work to and many, for this reason, soon give up the fascinating and delightful pastime. It is only by the pursuit of an ideal that satisfying results can be obtained. The "happy go lucky snap shooting" soon palls and satiates the mind because of its aimlessness.

There is an inherent love of nature in our hearts when we reach this planet. It is strong in childhood. If one keeps it alive the rambles in one of her pleasant places is most delightful. A cultivation of the love of fields and meadows, the mountain and seashore, and even the old ocean itself, produces an enlarged outlook upon life and the Creator of them all. This love of nature is a marvelous and forceful power, affording a never ending source of pleasure and benefit.

Go to the great out-of-doors with your camera as a companion, away from the irritating, nerve racking artificialities of life; there is art in nature if you can but see it; your camera is ever ready to aid you to make it permanent if you give it a chance; and when the day is done you return home hungry and weary in body, but refreshed for the business awaiting you.

My camera and I are close companions. We have travelled from the Atlantic to the Pacific and even on the ocean, and have found many delightful spots to "take" which prove a source of pleasure to myself and others. But, *keep an ideal before you*, follow it, and your albums will be books of beauty, forever. Forget this ideal and satisfaction is short lived. By the aid of the camera you can live over again the days in the open. Put into these pictures the choicest impressions. Try



SPRING.

WM. E. ZIEGENFUSS, M.D.

to make them mean to others what they meant to you—something that will touch a fellow-feeling and a vital chord in those who see your pictures.

You will pick up some “jarring” prints (we all do) but you need not entertain these when the permanent selections are made. Yes, follow any old road; it leads to nature’s pleasant places, and pictorial opportunities are scattered all along the way. The camera is the excuse for many a hike to the woods and the rivers. These pay well in the physical up-keep of our business weary bodies, and act as a clearing solution to an



WM. E. ZIEGENFUSS, M. D.

over-worked brain. Repeat as often as necessary. I would like to enlarge upon this phase of picture rambles. The branch of photography that induces one to take these is landscape work and nature photography. These will always be of vital interest.

A love for pure landscape, with an instinctive art feeling, has made many pictorialists. Landscapes, including water-scapes, offer the greatest variety in its materials for pictorial representation. There is much fine landscape work done by amateurs who have plate cameras, and who follow the lure of



ELLIOTT STUDIO.

the road and field. It is pleasant to record the fact that there is an ever increasing number of amateurs following this line of work, and recent years have shown much improvement in depicting nature. The material is there and can be found when the mind is alert—when the ideal is followed—when the eye is trained to see the artistic.

A most important point in the practice of photography is the development of taste and accurate observation. Without these little progress can be expected, and the lure of the field soon wanes. Try to interpret nature in her most alluring moods. It is necessary to educate the eye, to teach it what to see, to teach it the effects of light and shade, of aerial perspective, of value of colors. Experience and observation are the best, if not the only, teachers covering these features. Study the various scenes and subjects under all their aspects at different hours of the day and from several view points. The intensity and direction of the shadows make or mar a picture.

Of course there are gloomy day pictures for those who enjoy such but the absence of appropriate and well-placed shadows in a sunshine scene is inexcusable. The outdoor photographer is not restricted to pure landscape, but may specialize on trees, flowers, rocks and other forms of nature and know that he is reaping twice,—for health and for art.

It is not the intention of this article to teach composition. Others have done that better than I could. But I earnestly urge all who desire the best in photography to study some of the excellent works upon this subject, and to subscribe and read several magazines on photography. Then as you wander through the fields and woods, or by the river side, always keep in mind these laws of composition, and you will see how nature constantly makes use of them, and how much knowledge of real art may in this way be acquired. After some practice you will be able to pick up treasures by the wayside undreamed of and unseen by the careless eye.

Twelve Points Worth While

Experience has taught me that—

- 1st. A long focus plate camera is best for landscape.
- 2nd. Almost any lens, even a pin hole and uncorrected lens will make a picture. I prefer a fully corrected lens.

3rd. All plates are good, but the best results are obtained on orthochromatic double-coated with ray filter where much color predominates.

4th. Extended scenes and those which charm the eye by reason of color are disappointing when shown in monochrome.

5th. Exposures with sun in back tend toward flatness.

6th. There is always a "best viewpoint."

7th. The middle of the day is least suited for pictures.

8th. A scene full of highlights must have full exposure.

9th. Don't guess at exposure—*know*—a good meter doesn't cost as much as plates.

10th. Don't try for the "grand in nature"—you seldom succeed in getting these.

11th. If at first you don't succeed try again. Prize pictures are usually produced only after many trials.

12th. Doing all the work yourself is the only way to learn where and how you can improve in the interpretation of nature as you see it.

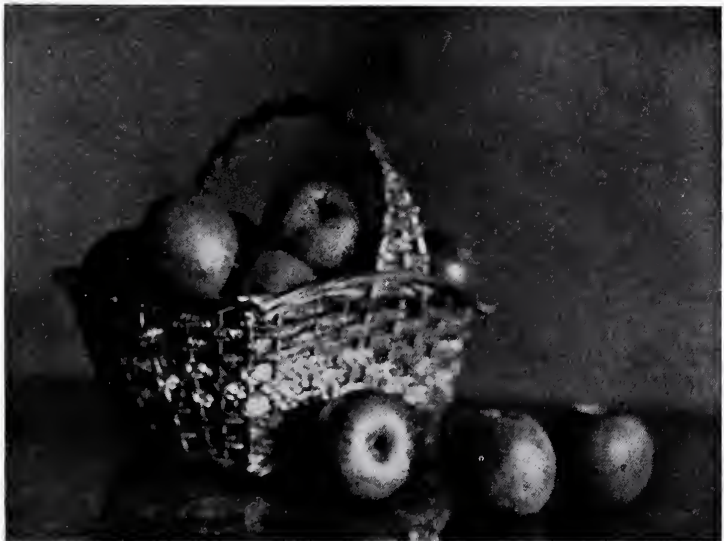

APPLES.

BERTHA M. MILLER.

American Annual Formulary

In the following section we have gathered together a typical collection of Formulae and Tables, which will assist the photographer in his every-day work. It will be noticed that makers' formulae are omitted. These can best be obtained by direct application to the makers. The appended formulae are selected from the working methods of practical photographers.—Editor.

TRAY DEVELOPERS FOR PLATES AND PAPERS

Amidol. A concentrated developer for plates.—Water, 13 ounces; sulphite of soda (anhydrous), $1\frac{1}{4}$ ounces; when dissolved add amidol, $\frac{1}{4}$ ounce. The solution keeps fairly well in bottle completely full and well corked. For use take 1 ounce of the concentrated solution and dilute with 3 or 4 ounces of water.

Amidol. For gaslight papers.—An excellent developer for those subject to metol poisoning. (V. Serin.) Amidol, 60 grains; sulphite of soda (anhydrous), 325 grains; potassium bromide, 10 grains; water, 20 ounces. Will keep only three or four days. Time of development about $\frac{1}{2}$ minute.

Diamidophenol. For Paper (Edwin Loker).—Water, 20 ounces; sodium sulphite (anhydrous), $1\frac{1}{2}$ ounces; sodium bisulphite, 10 drams; bromide potassium, 10 grains. To use, take 2 ounces and add 6 grains diamidophenol.

Ferrous Oxalate. For Papers (M. G. Lovelace).—No. 1. Hot water, 1000 CC. Dissolve ferrous sulphate, 250 grams; add slowly sulphuric acid, 3 CC. No. 2. Potassium oxalate (neutral), 250 grams; potassium bromide, 1 gram; hot water to make 1000 CC. Add 1 part of No. 1 to 4 parts of No. 2. After development wash in acetic acid stop bath.

Hydrochinon. (M. G. Lovelace).—Water, 850 CC.; hydrochinon, 6.5 grains; sulphite soda (anhydrous), 30 grains; carbonate soda (dry), 100 grains; potassium bromide (saturated solution), 20 to 30 drops.

Hydrochinon.—For over-exposure plates to obtain contrasty negatives (B. H. Allbee).—No. 1, water, 8 ounces; sulphite of soda (anhydrous), $\frac{1}{2}$ ounce; hydrochinon, 80 grains. No. 2, water, 8 ounces; carbonate of soda (dry), 1 ounce; potassium bromide, 40 grains. Take equal parts of No. 1 and No. 2. Temperature, 70 degrees.

Metol (H. W. Hales).—Metol, 60 grains; warm water, 16 ounces; sulphite of soda (anhydrous), $\frac{1}{2}$ ounce; carbonate of soda (dry), $\frac{1}{2}$ ounce. Dissolve metol in warm water, then add the sulphite and carbonate in order named. Cool. Can be used repeatedly. For developing papers add a few drops of 10 per cent. solution of bromide of potassium.

Metol-Hydroquinone for Orthochromatic Plates.—Water, 20 ounces; metol, 14 grains; potassium metabisulphite, 18 grains; hydroquinone, 56 grains; sulphide of soda (anhydrous), 1 ounce; carbonate of soda (dry), $1\frac{3}{4}$ ounces. Use 1 drop of a 10 per cent. potassium bromide solution to each ounce only if necessary.

Para-Amidophenol (M. G. Lovelace).—Dissolve 150 grains sulphite soda (anhydrous) in 800 CC. hot water; add 20 grains para-amidophenol; dissolve 8 grains lithium hydrate in 100 CC. water, and add until precipitate formed is dissolved; then add water to make 1000 CC.

Paramidophenol-Hydrochloride (S. Wein).—Paramidophenol-hydrochloride, 48 grains; carbonate soda (dry), 1 ounce; sulphite soda (anhydrous), 1 ounce; water, 20 ounces. For use, dilute with equal quantity of water.

Pyro. For Prints (M. G. Lovelace).—No. 1 Pyro, 12 grains; sulphite soda (anhydrous), 80 grains; potassium ferrocyanide, 2 grams; water, 500 CC. No. 2 Sodium hydrate, 4 grams; water, 500 CC. To use, one part each with water 2 parts. Add 3 drops saturated solution bromide of potassium to every 400 CC. of developer.

Pyro. For Night Subjects (Robert Dykes).—Stock solution—Pyro, 1 ounce; potassium bromide, 60 grains; potassium meta-bisulphite, 50 grains; distilled water to make 12 ounces. No. 1. Take stock solution 3 ounces, add 2 ounces boiled water. No. 2. Sulphite soda (anhydrous), 1 ounce; carbonate soda (dry), 1 ounce; water (boiled) to make 20 ounces. For use, 4 drams No. 1 to 5 drams No. 2 in 16 ounces of water.

Pyro. For Overtimed Plates (J. D. Elliott).—Sulphite soda, 40° solution, 4 ounces; water, 4 ounces; pyro, 10 grains. Immerse plates in this solution for 20 minutes in the dark; then add to above solution ½ drachm carbonate soda, 20° solution. When image appears add one more drachm of the carbonate soda solution.

Pyro. For Plates (J. D. Elliott).—Sulphite soda, 40° solution, 4 ounces; carbonate soda, 20° solution, 4 ounces; pyro, 10 grains.

Pyro-Metol. For Plates (H. M. Long).—A. Water, 22½ ounces; metabisulphite, 2 dram; metol, 60 grains; pyro, 1 ounce. B. Water, 16 ounces; sulphite soda (anhydrous), 2 ounces. C. Water, 16 ounces; carbonate soda (dry), 1 ounce. Normally used 1 ounce of each stock to 16 of water.

Pyro Soda. For Plates (Mellen).—No. 1 Water, 20 ounces; sulphite soda (anhydrous), 2 ounces; carbonate soda (dry), 2 ounces. Dissolve the sulphite first and then add the carbonate. No. 2. Water, 6 ounces; pyro, 1 ounce. For correct exposure take 1 dram of No. 2; 1 ounce of No. 1, and add 2 ounces of water. For snapshots or plates thought to be under-exposed, use 1 dram of No. 2, 1½ drams of No. 1, and 6 ounces of water. For over-exposure take 2 drams of No. 2, 1 ounce of No. 1 and 6 ounces of water. Or, instead of the 2 drams of No. 2 in this solution use 1 dram of No. 2 and 10 drops of a 10 per cent. solution of potassium bromide.

Pyro-Metol-Acetone. For Plates (Cramer).—No. 1. Water, 60 ounces; metol, 1 ounce; citric acid, 40 grains; pyro, 1 ounce; sulphite soda (anhydrous), 6 ounces. No. 2. Water, 48 ounces; liquid acetone, 12 ounces. For plates take 1 ounce No. 1, 1 ounce No. 2, water 5 ounces. For tank take 1 ounce No. 1, 1 ounce No. 2; water 13 ounces.

TANK DEVELOPERS FOR NEGATIVES

Metol-Hydro (Frew).—Water, 12 ounces; metol, 7½ grains; sulphite soda (anhydrous), 274 grains; hydroquinone, 30 grains; carbonate soda (anhydrous), 150 grains; bromide potassium, 2 grains. For use to each ounce of above add 4 ounces of water; temperature, 65 degrees; time, 12 minutes.

Monomet-Hydro-Pyro (John Boyd).—Monomet, 4 grains; hydroquinone, 4 grains; pyro, 4 grains; metabisulphite potassium, 4 grains; carbonate of soda, dessicated, 40 grains; sulphite of soda (anhydrous),

60 grains; bromide of potassium, 1 grain; water, 4 ounces. For tank development use 28 ounces of water. Development 20 minutes at 65 degrees.

Pyro (George D. Jopson).—No. 1. Water, 16 ounces; meta-bisulphite of potash, 70 grains; pyro, 1 ounce; bromide potassium, 8 grains. Mix in order given. No. 2. Sulphite soda, 60° test. No. 3. Carbonate soda, 40° test. To use, mix 2½ ounces of No. 1, 2 and 3 in rotation, add 57 ounces of water. Develop 20 minutes at 65°.

Rodinal or Azol.—Water, 60 ounces; rodinal or azol, 1 ounce; temperature, 65 degrees; time, 25 minutes.

DEVELOPERS FOR LANTERN SLIDES

Hydroquinone (B. H. Allbee).—No. 1. Hydroquinone, 150 grains; metabisulphite potash, 10 grains; bromide potassium, 50 grains; water, 20 ounces. No. 2. Sulphite of soda (anhydrous), 1 ounce; caustic soda, 100 grains; water, 20 ounces. Take equal parts of No. 1 and No. 2.

Hydroquinone. One Solution for Warm Tones (A. H. Farrow). Hydroquinone, 1 dram; sulphite of soda (anhydrous), 2 drams; carbonate of soda (dry), 4 drams; bromide of potassium, 20 grains; water, 12 ounces.

Hydroquinone. For Colder Tones (B. H. Allbee).—No. 1. Hydroquinone, 60 grains; sulphite of soda (anhydrous), 1 ounce; citric acid, 10 grains; bromide potassium, 10 grains; water 10 ounces. No. 2. Carbonate of soda (dry), 1 ounce; water, 10 ounces. Use equal parts.

FIXING BATHS AND HARDENERS

Acid Fixing Bath (Carbutt).—Sulphuric acid, 1 dram; sodium hyposulphite, 16 ounces; sulphite of soda (anhydrous), 2 ounces; chrome alum, 1 ounce; warm water, 64 ounces. To prepare the bath, dissolve the hypo in 48 ounces of water, the sulphite of soda in 6 ounces; mix the sulphuric acid with 2 ounces of the water and pour slowly into the sulphite solution, and then add to the hypo solution. Dissolve the chrome alum in 8 ounces of water; add to the bulk of the solution and the bath is ready for use.

Fixing Bath for Lantern Slides (B. H. Allbee).—Sulphuric acid, 1 dram; hypo, 16 ounces; sulphite of soda (anhydrous), 1 ounce; chrome alum, 1 ounce; water, 64 ounces.

Plain Fixing Bath.—Dissolve 1 pound of sodium hyposulphite in 2 quarts of water, or 4 ounces of the hypo in a pint of water, according to the bulk of the solution required.

Hardener for Fixing Bath (Beach).—Water, 40 ounces; sulphite of soda (anhydrous), 3 ounces; powdered alum, 16 ounces; acetic acid, 40 ounces. Add in the order given and shake well until dissolved. Of the above add 16 ounces to each gallon of hyposulphite of soda solution, testing 70 to 80 degrees.

Hardening Negatives.—Immerse them for a few minutes in formalin, 1 ounce; water, 30 ounces.

INTENSIFICATION

Intensifier, One Solution (F. M. Steadman).—No. 1. Bichloride of mercury, ½ ounce; water, 10 ounces. No. 2. Iodide of potassium, 5 drams; water, 1½ ounces. Add to No. 1. No. 3. Hyposulphite of soda, 1 ounce; water, 2½ ounces. Add to the previous mixture. This clears the solution when it is ready for use for local intensification. For tray intensification add more water to slow its action.

Intensifying with Red Ink (E. M. Cohen).—Soak the negative well. Put teaspoon of red ink into tray of water and rock until mixed.

Immerse negatives face up till well and evenly colored, then without washing put in drying frame. If left in solution too long will be over dense, in which case several trays of clear water will eliminate some of the color.

The intensification is permanent without the danger of negative going bad, as is the case when mercury is used.

Intensifier—Mercuric Chloride Process.—No. 1. Mercuric chloride, 200 grains; bromide of potassium, 120 grains; water, 6½ ounces. No. 2. Sulphite of soda (anhydrous), 1 ounce; water, 4 ounces. The well-washed negative, free from hypo, must be thoroughly bleached in No. 1; well washed; and then blackened in No. 2. After blackening it is well washed again.

REDUCTION

Reducer, Single Solution (F. M. Steadman).—Red prussiate of potash, size of pea; hyposulphite of soda, six times that volume; water, 6 ounces (for local reduction, 1½ ounces). When reduced wash thoroughly.

Reducer—Ammonium Persulphate.—Ammonium persulphate, 15 grains; water, 1 ounce. The solution should be made just before use. The negative must be perfectly free from hypo or it will be stained by the persulphate. When the desired reduction has been reached, transfer the negative without washing to a 10 per cent. solution of anhydrous sodium sulphite. Wash finally for 15 or 20 minutes.

Reducer—Farmer's.—Dissolve 1 ounce of potassium ferricyanide in 9 ounces of water and make up to 10 ounces, forming a 10 per cent. solution. Label this poison. Thoroughly wet the negative to be reduced. Take enough fresh plain hypo fixing bath for the purpose, and add to it enough of the ferricyanide solution to make it a light straw color. The negative to be reduced is immersed in this solution, when it will be seen to lose density. Rock the tray to insure evenness of action. This reducer can also be used for local treatment.

PRINTING PROCESSES

Blue Prints

Blue Printig Sensitizing Formula (Brown).—A. Dissolve 110 grains ferric ammonium citrate (green) in 1 ounce of water. B. Dissolve 40 grains of potassium ferricyanide in 1 ounce of water. These two solutions are made up separately. They are then mixed together and kept in a stoneware bottle, but the single solution should always be filtered before use. The mixture will retain its good qualities for months if kept from the light.

(Millen).—Potassium ferricyanide, 1 ounce; ammonio-citrate of iron, 1½ ounces; distilled water, 10 ounces. Mix thoroughly and filter. The solution should have a deep wine color and dry on the paper a lemon-yellow. If the solution is green and has a precipitate, the ammonio-citrate is old and spoiled. The mixture should be kept from the light.

Bromide Paper

Bromide Paper Developers: Hydroquinone-metol. No. 1. Water, 10 ounces; hydroquinone, 52 grains; potassium metabisulphite, 18 grains; sulphite of soda (anhydrous), 5 drams; carbonate of soda, 1¼ ounces. No. 2. Water, 10 ounces; metol, 30 grains; carbonate of soda, 5 drams; sulphite of soda (anhydrous), 5 drams. One or two drops of a potassium bromide 10 per cent. solution added to 1 ounce of the mixed developer will increase contrast and keep the whites

pure. Equal parts of 1 and 2 give excellent prints from a normal negative; one part of 1 and two of 2 give gray prints with maximum half-tone and gradation; two parts of 1 and one of 2 give vigorous prints from soft delicate negatives.

Amidol for rich blacks (freshly prepared). Distilled (or boiled) water, 4 ounces; sulphite of soda (anhydrous), 45 grains; amidol, 10 to 15 grains. Add a drop of 10 per cent. bromide solution to each ounce of developer.

Sepia Tones: Hypo Alum.—Hyposulphite of soda, 5 ounces; ground alum, 1 ounce; boiling water, 70 ounces. Dissolve the hypo in the water, and then add the alum slowly. A milk-white solution results which should be decanted when clear. It is not used until cold (about 60° Fahr.).

Sepia Tones: Sulphide of Sodium.—The fixed and washed print is treated with one of the following solutions: (1) Potassium ferricyanide, 10 grains; potassium bromide, 10 grains; water, 1 ounce; or (2) potassium ferricyanide, 20 grains; sodium chloride (common salt), 30 grains; water, 1 ounce. The image will be bleached by either of these solutions in a few minutes, the whitish appearance of the deposit being caused by its change into a salt of silver. After 5 minutes in running water apply the sulphuretting solution: Dissolve 3 ounces of sodium monosulphide in 15 ounces of water; boil the solution for about 10 minutes, filter off the black precipitate formed, and when cooled make up to 25 ounces with water. To tone take of the sulphide solution 1 ounce and add water 12 to 20 ounces.

Red Tones: Copper.—Dissolve 100 grains of ammonium carbonate in 2 ounces of water, and in this solution dissolve 10 grains of sulphate of copper. Then add 20 grains of potassium ferricyanide. A clear, dark green solution results which gives a red-chalk tone in about 3 minutes. Tone until the deepest shadow is converted, and then wash the print for 10 minutes.

Green Tones: Vanadium.—Bleach print in the following: Potassium ferricyanide, 10 grains; ammonium carbonate, 100 grains; water, 1 ounce. Wash well and apply: Ferric chloride, 2 grains; vanadium chloride, 2 grains; ammonium chloride, 4 grains; hydrochloric acid, 5 minims; water, 1 ounce.

Blue Tones: Iron.—Bleach print in: Potassium ferricyanide, 10 grains; ammonium carbonate, 100 grains; water, 1 ounce; then tone in ferric chloride, 5 grains; hydrochloric acid, 5 minims; water, 1 ounce.

To prevent blistering on bromide paper (P. L. Anderson).—Immerse after fixing and before washing from 10 to 15 minutes in water, 10 ounces; formaldehyde, 1 ounce. A 10 per cent. solution of chrome alum will do equally well.

To make bromide paper translucent (P. L. Anderson).—Lay the paper negative face down on a blotter and paint thinly with the following mixture. Give three coats. Turpentine, 3 ounces; powdered resin, 1 ounce; gum elemi, 1 ounce; paraffine wax, $\frac{1}{2}$ ounce. Heat with stirring until it begins to boil. Allow to cool slightly and add turpentine, 3 ounces.

Carbon Tissue

Carbon Tissue, Sensitizer for (Bennett).—Potassium bichromate, 4 drams; citric acid, 1 dram; strong ammonia water, about 3 drams; water, 25 ounces; dissolve the bichromate and citric acid in hot water, and add sufficient ammonia to change the orange color of the solution to lemon-yellow. Sensitize for 90 seconds; reducing the water softens the gradation in the print; increasing it to 30 ounces gives more vigor.

Carbon Lantern Slides.—Prepare the glass by coating with the following preparation: 180 grains of Nelson's Gelatine No. 1, in 20 ounces

water. Add 10 grains bichromate of potash. Dry and allow the plate to be exposed to light for a couple of days to make the coating thoroughly insoluble. Sensitizer for tissue: 1 per cent. to $1\frac{1}{4}$ per cent. solution of bichromate of potash. Immerse 2 minutes. Print deeply; expose twice as long as ordinary paper print. Develop in hot water as usual.

Gum Bichromate

Gum Bichromate (Casper Millar). A.—Gum arabic, $1\frac{1}{4}$ ounces; water, $3\frac{1}{2}$ ounces; salicylic acid, 4 grains.

B.—Chrome alum, 45 grains; water, $3\frac{1}{2}$ ounces. Grind A and B with water and pigment, brush over paper, dry and store.

Suggested formula.—A, 2 ounces; B, $1\frac{1}{2}$ drams; carbon black, 10 grains; sensitize for 2 minutes in 5 per cent. bichromate solution.

Kallitype

Kallitype Sensitizer for Black Tones (J. Thomson).—Distilled water, 1 ounce; ferric oxalate (Merck's or Mallinckrodt's), 15 grains; citrate of iron and ammonia (brown scales), 25 grains; chloride of copper, 8 grains; oxalate of potassium, 35 grains; oxalic acid, 15 grains; silver nitrate, 15 grains; gum arabic, 10 grains. For greater contrast add 1 to 10 drops 5 per cent. bichromate of potassium solution.

Developer: Stock Solution.—Distilled water, 1 ounce; silver nitrate, 40 grains; citric acid, 10 grains; oxalic acid, 10 grains. Filter. Normal developer 1 dram stock solution and 7 drams of water.

Platinum Papers

Platinum Sensitizer (P. L. Anderson).—Stock solutions: I. Water, hot, distilled, 2 ounces; ferric oxalate, 240 grains; oxalic acid, 16 grains. II. Water, hot, distilled, 2 ounces; ferric oxalate, 240 grains; oxalic acid, 16 grains; potassium chlorate, 4 grains. III. Water, distilled, 19 drams; potassium chloroplatinite, 219 grains ($=\frac{1}{2}$ ounce). Keep in amber glass bottles or in the dark. For use take: I, 22 mm.; II, 0 mm.; III, 24 mm. Gives very soft prints. Or, I, 12 mm.; II, 10 mm.; III, 24 mm. Results about the same contrast as a P. O. P. print. Or, I, 0 mm.; II, 22 mm.; III, 24 mm. Gives extreme contrast.

Above quantities sufficient for a 10 x 12 sheet of ordinary paper. Very smooth requires less and very rough more, up to 25 per cent. additional. Apply with a soft fitch or camel-hair brush, allow to surface dry, and make bone-dry over a stove or gas-jet. Should dry in not less than five or more than ten minutes.

Platinum: Sensitizing Gold Bath and Sepia Papers. A.—Chloroplatinite of potassium, 15 grains; distilled water, 90 minims.

B.—Ferric oxalate, 21 grains; oxalic acid, 2 grains; distilled water, 183 minims. For cold bath paper, mix A and B, and add 15 minims of water. For sepia paper mix A and B and add 15 minims of a 5 per cent. solution of mercuric chloride. The addition of a few grains of potassium chlorate to any of the above gives increased contrast in the print. From 140 to 170 minims of solution are sufficient to coat a sheet of paper 20 x 26 inches.

Platinum Prints: to Intensify. A.—Sodium formate, 45 grains; water, 1 ounce.

B.—Platinum perchloride, 10 grains; water, 1 ounce.

C.—For use, take 15 minims each of A and B to 2 ounces of water. Immerse prints until sufficiently intensified, then remove and wash.

Platinum Prints to Distinguish from Bromide.—Soak the print in saturated solution of mercuric chloride; a platinum print will not change; a bromide print will bleach.

Salted Papers

Salted Paper Prints: Sensitized with the following: Silver, 480 grains Troy; water, 11 ounces. Dissolve and pour off 2 ounces, and to the 9 ounces left add strong aqua ammonia to form a precipitate and redissolve the precipitate, then add the remaining 2 ounces which will form another precipitate; to this add 9 drops of nitric acid C. P. Apply this to the paper with a tuft of cotton.

Any good toning bath will give good results, such as—Chloride aluminum, 80 grains; bi-carbonate soda, 360 grains; water, 48 ounces. When mixed this will form a flacky hydrate which will settle to the bottom. It can be strained through clean washed muslin. To prepare a small bath for toning, take 12 ounces of the stock solution and add sufficient gold to tone in 8 to 10 minutes. The gold solution must be neutralized with bi-carbonate soda before adding to the above bath. When the prints reach the desired tone throw them into a bath of salt water, made of water, 1 gallon; table salt, 1 ounce.

Printing Out Papers.

Gold Toning (B. H. Allbee).—No. 1, 10 per cent. solution sulphocyanide of potassium; No. 2, 15 grains chloride of gold in $7\frac{1}{2}$ ounces of water; No. 3, 10 per cent. solution phosphate of soda; No. 4, saturated solution borax. Take No. 1, 1 dram, water, 8 drams; No. 2, 4 drams; No. 3, 1 dram; No. 4, 2 drams. In this put print in dry. Toning should be complete in two minutes. Wash as usual.

Gold Toning.—For blue-black tones, for slight strengthening, and for converting rusty black into pure black. Soak prints in warm water, lay on warm glass, brush over glycerine and blot off. Pour on few minims of solution of gold chloride (1 grain per dram), and rapidly brush in all directions. When toned, rinse, and sponge back and front with: Metol, 50 grains; sodium sulphite, 1 ounce; potassium carbonate, $\frac{1}{2}$ ounce; water, 20 ounces. Tone in daylight. Do not tone sepias or old prints in this solution.

Gold Toning—To Give Black Tones (A. B. Klugh).—Solution A. Sodium thiosulphate (hypo), 40 grams; water, 100 cc. Solution B. Lead nitrate, 5 grams; acetic acid, glacial, 5 cc.; water, 50 cc. Add to solution A enough of B to produce a slight milkiness. Filter and add 25 cc. of a 1% solution of good chloride. Print deeply and tone until a warm black is produced.

MISCELLANEA

Adhesive for Labels.—Soak 1 part of the best glue in water until thoroughly swollen, add a little sugar candy, 1 part of gum arabic and 6 parts of water. Boil with constant stirring over a spirit lamp until the whole gets thin. Coat sheets of paper with it; let dry and cut up into convenient sizes.

Autochromes.—Sensitizing to get more speed (M. G. Lovelace).—In complete darkness bathe plates in the following solution: Distilled water, 66 cc.; ethyl alcohol, pure, 90 deg., 33 cc.; dye solution, 2 cc.; ammonia, .30 cc. The dye solution is a mixture of pinachrome, pina verdol and pinacyanol, 1 part of each in 1000 of alcohol. Bathe plates for five minutes and dry away from dust. These plates require a special filter the formula being: Hard gelatine, 3 gms.; distilled water, 100 cc.; filter yellow K, 1 per cent. solution, 2.5 cc. Use 1 cc. to each 10 square centimeters of surface. These plates have about five times the speed and it is possible to make snap shots with them if a lens working at F/4.5 and F/5.6 is used.

Blackening Mixture.—Dissolve a 4-ounce stick of licorice in 8 ounces of water with the aid of gentle heat. When dissolved rub into the mixture 1 ounce of burnt sienna in powder, using the back of a spoon for this purpose. When cold, bottle for use.

Blackening Brass.—Make two solutions: Copper nitrate, 200 grains; water, 1 ounce. Silver nitrate, 200 grains; water, 1 ounce. Mix the solutions; clean the article well; dip it in the solution for a moment; withdraw it; dry it; and heat it strongly.

Black, Dead, for Wood.—Shellac, 40 parts; borax, 20 parts; glycerine, 20 parts; water, 500 parts. When dissolved, add 50 parts aniline black.

Cleaning Greasy Bottles.—Wash with benzine, or permanganate of potassium, to which has been added some hydrochloric acid.

Bottles that have contained resinous substances, wash with potash or soda and rinse with alcohol. Bottles that have contained essences, wash with sulphuric acid, then with water.

Clearing Stained Negatives.—Dissolve $\frac{1}{8}$ ounce of pulverized alum in 20 ounces of water and add 1 dram of sulphuric acid. Immerse the stained plate in this solution for a few minutes; remove plate, wash and then set in the rack to dry.

Film: to Remove from Glass: Make two solutions. A.—Sodium fluoride, 6 grains; water, 4 ounces.

B.—Sulphuric acid, 6 drops; water, 1 ounce. Place the negative in solution A for 2 minutes and then place directly in solution B. After another 2 minutes lift the film with the finger from one corner of the plate. It will soon leave the glass.

Firelight Effects on Developing Paper (H. S. Hood). No. 1.—Water, 5 drams; copper sulphate, 10 per cent. solution, 15 minims; ammonium carbonate, 10 per cent. solution. Add till precipitate first formed is redissolved.

No. 2.—Water, $4\frac{1}{2}$ ounces; potassium ferricyanide, $\frac{6}{10}$ drams. Mix separately and add No. 2 to No. 1. The print will turn bright red. Wash well.

Ground Glass: Substitutes for. 1.—Paraffine wax makes an excellent substitute for ground glass if the latter should get broken. Iron the paper onto a sheet of plain glass. It is more transparent than the focusing screen and the image will appear clearer; hence, in exposing allowance must be made for the difference in illumination.

2.—Resin dissolved in wood alcohol and blown over the glass; this must not be scratched; it gives a very fine-grained ground glass effect.

3.—White wax, 120 grains; ether, 1 ounce.

Ground Glass Varnish: Sandarac, 90 grains; mastic, 20 grains; ether, 2 ounces. Dissolve the resins in the ether and add benzole $\frac{1}{2}$ to 1 $\frac{1}{2}$ ounces.

Lens: to Clean.—The lens should always be kept free from dust or other impurities. To clean it, spread upon a table a clean sheet of paper; take the lens apart, and with a camel-hair brush dust each of the combinations on both sides. If the surfaces of the lenses are very dirty and have lost their polish, make up the following: Nitric acid, 3 drops; alcohol, 1 ounce; distilled water, 2 ounces. Dip a tuft of filtering cotton in this solution, rub each side of the lens, then polish with an absolutely clean chamois. Clean the lens tube before replacing the lenses, each of which should be finally dusted with a camel-hair brush.

Moonlight Effects on Developing Paper (H. S. Hood).—Immerse in water, 5 ounces; ferric ammonium citrate, 12 grains; potassium ferricyanide, 12 grains; nitric acid, $\frac{2}{5}$ drams. Prints will assume a blue color. Wash until whites become clear.

Mounting Without Cockling (W. S. Davis).—Coat back of dry print with as strong a solution of warm gelatine (pure table gelatine will do) as can be spread easily. Allow to dry, then attach to mount by dampening the amount with water, then lay print in desired position; cover with a sheet of bond or smooth paper, and apply a warm flat iron until the gelatine melts. Very effective for thin mounting material, as there is no cockling if the mount contains just the right amount of water.

Non-Abrasion Soda Mixture (M. G. Lovelace).—Sulphite of soda (anhydrous), 1 ounce; carbonate of soda (dry), 370 grains; hypo, 8 grains. A mixture in these proportions may be used in place of sodas for paper; or carbonate of soda (dry), 28.75 grams; hypo, 38.75 grams; water to 500.00 c.c.

Paste, Starch (A. Lomax).—Powdered starch, 1 ounce; cold water, 12 ounces. Mix smooth with a glass rod, heat to boiling point. Boil half a minute stirring all the time. Use cold.

Poisons and Antidotes.—Administer the antidote as soon as possible. If a strong acid or alkali, or cyanide of potassium, has been swallowed, lukewarm water in large quantities should be swallowed at once. Where strong acids or alkalies have not been swallowed, rid the stomach of the poison by vomiting; for this purpose take 25 grains of zinc sulphate in warm water.

Polished Surfaces: to Photograph.—Smear the surface with soft putty so as to deaden the reflections. Photograph the article against a black background, and stop off all reflections, allowing the light to come from one direction only. To photograph hollow cut glassware fill with ink or aniline black water dye. Before photographing machinery deaden the bright parts with putty.

Safe Light for Panchromatic Plates.—Take old dry plates and coat with the following: Water, 10 ounces, tartrazine, 75 grains; patent blue A, 75 grains; naphthol greens, 75 grains; sulphuric acid, 30 minims. Stain the plates as deeply as possible. Use two plates.

Stains: to Remove from the Hands.—Developer stains: solution of citric or oxalic acid. Silver nitrate stains: Water, 4 ounces; chloride of lime, 350 grains; sulphate of soda, 1 ounce. Apply with a brush.

Tarnished Daguerreotypes, to Restore.—Remove the silvered plate from the case and place it, image uppermost, under a box lid or other protector from dust, etc. Put a small piece of potassium cyanide into a graduate and pour over it 1 or 2 ounces of water. Hold the daguerreotype by the corner with a pair of pliers, rinse it in clear running water, then pour over it the weak cyanide solution (a 3 per cent. solution is usually employed), and return it to the graduate. Repeat this operation several times until the discoloration quite disappears. Wash well in running water, and then, before the surplus water has time to collect in tears upon the image, begin to dry the plate gradually over a spirit lamp, holding the plate in an inclined position so that it will dry from the uppermost corner. The secret of success is in the use of pure water for the final washings and the drying of the image without check or the formation of tears.

Test for Hypo: Potassium permanganate, 2 grains; potassium carbonate, 20 grains; distilled water, 40 ounces. Soak the plate or print to be treated in water for one hour, then remove and add to the water a few drops of the above solution, which will turn a greenish yellow or brown if the water is not free from hypo.

To Flatten Double-weight Prints (George D. Jopson).—A—9 ounces boiling water; $\frac{1}{2}$ ounce gelatine. B—3 ounces boiling water; $\frac{1}{2}$ drachm alum. C—2 drachms oil of cloves. Mix and strain through cheese cloth while hot. To use take a little from the stock and place in a cup. Place cup in hot water until backing is dissolved. Apply very thin to back of print with soft cloth or a tuft of cotton.

UNITED STATES WEIGHTS AND MEASURES

According to Existing Standards

LINEAR

	Inches	Feet	Yards	Rods	Fur's	Mi.
12 inches = 1 foot.	12 =	1				
3 feet = 1 yard.	36 =	3 =	1			
5.5 yards = 1 rod.	198 =	16.5 =	5.5 =	1		
40 rods = 1 furlong.	7,920 =	660 =	220 =	40 =	1	
8 furlongs = 1 mile.	63,360 =	5,280 =	1,760 =	320 =	8 =	1

SURFACE—LAND

	Feet	Yards	Rods	Roods	Acres
144 sq. ins. = 1 sq. ft.					
9 sq. ft. = 1 sq. yd.	9 =	1			
30.25 sq. yds. = 1 sq. rod.	272.25 =	30.25 =	1		
40 sq. rods = 1 sq. rood.	10,890 =	1,210 =	40 =	1	
4 sq. roods = 1 acre.	43,560 =	4,840 =	160 =	4 =	1
640 acres = 1 sq. mile.	27,878,400 = 3,097,600 = 102,400 = 2,560 = 640				

VOLUME—LIQUID

	Gills	Pints	Gallon	Cub. In.
4 gills = 1 pint.	32 =	8 =	1 =	231
2 pints = 1 quart.				
4 quarts = 1 gallon.				

FLUID

Gallon	Pints	Ounces	Drachms	Minims	Cubic Centimetres
1 =	8 =	128 =	1,024 =	61,440 =	3,785,435
	1 =	16 =	128 =	7,680 =	473,179
		1 =	8 =	480 =	29,574
			1 =	60 =	3,697

16 ounces, or a pint, is sometimes called a fluid pound.

TROY WEIGHT

Pound	Ounces	Pennyweights	Grains	Grams
1 =	12 =	240 =	5,760 =	373.24
	1 =	20 =	480 =	31.10
		1 =	24 =	1.56

APOTHECARIES' WEIGHT

lb.	℥	ʒ	℥	gr.	Grams
Pound	Ounces	Drachms	Scruples	Grains	
1 =	12 =	96 =	288 =	5,760 =	373.24
	1 =	8 =	24 =	480 =	31.10
		1 =	3 =	60 =	3.89
			1 =	20 =	1.30
				1 =	.06

The pound, ounce, and grain, are the same as in Troy weight.

AVOIRDUPOIS WEIGHT

Pound	Ounces	Drachms	Grains (Troy)	Grams
1 =	16 =	256 =	7,000 =	453.60
	1 =	16 =	437.5 =	28.35
		1 =	27.34 =	1.77

ENGLISH WEIGHTS AND MEASURES

APOTHECARIES' WEIGHT

20 Grains	= 1 Scruple	= 20 Grains.
3 Scruples	= 1 Drachm	= 60 Grains.
8 Drachms	= 1 Ounce	= 480 Grains.
12 Ounces	= 1 Pound	= 5,760 Grains.

FLUID MEASURE

60 Minims	= 1 Fluid Drachm	
8 Drachms	= 1 Fluid Ounce	
20 Ounces	= 1 Pint	
8 Pints	= 1 Gallon	

The above weights are usually adopted in formulas.

All Chemicals are usually sold by

AVOIRDUPOIS WEIGHT

27 $\frac{1}{32}$ Grains	= 1 Drachm	= 27 $\frac{1}{32}$ Grains
16 Drachms	= 1 Ounce	= 437 $\frac{1}{2}$ Grains
16 Ounces	= 1 Pound	= 7,000 Grains

Precious Metals are usually sold by

TROY WEIGHT

24 Grains	= 1 Pennyweight	= 24 Grains
20 Pennyweights	= 1 Ounce	= 480 Grains
12 Ounces	= 1 Pound	= 5,760 Grains

NOTE.—An ounce of metallic silver contains 480 grains, but an ounce of nitrate of silver contains only 437 $\frac{1}{2}$ grains.

UNITED STATES FLUID MEASURE

Gal.	Pints.	Ounces.	Drachms.	Mins.	Cub. In.	Grains.	Cub. C.M.
1	= 8	= 128	= 1,024	= 61,440	= 231.	= 58,328.886	= 3,785.44
	1	= 16	= 128	= 7,680	= 28.875	= 7,291.1107	= 473.18
		1	= 8	= 480	= 1.8047	= 455.6944	= 29.57
			1	= 60	= 0.2256	= 56.9618	= 3.70

IMPERIAL BRITISH FLUID MEASURE

Gal.	Pints.	Ounces.	Drachms.	Mins.	Cub. In.	Grains.	Cub. C.M.
1	= 8	= 160	= 1,280	= 76,800	= 277.27384	= 70,000	= 4,543.732
	1	= 20	= 160	= 9,600	= 34.65923	= 8,750	= 567.966
		1	= 8	= 480	= 1.73296	= 437.5	= 28.398
			1	= 60	= 0.21662	= 54.69	= 3.550

METRIC SYSTEM OF WEIGHTS AND MEASURES

MEASURES OF LENGTH

DENOMINATIONS AND VALUES		EQUIVALENTS IN USE
Myriameter.....	10,000 meters.	6.2137 miles.
Kilometer.....	1,000 meters.	.62137 mile, or 3,280 ft. 10 ins
Hectometer.....	100 meters.	328. feet and 1 inch.
Dekameter.....	10 meters.	393.7 inches.
Meter.....	1 meter.	39.37 inches.
Decimeter.....	1-10th of a meter.	3.937 inches.
Centimeter.....	1-100th of a meter.	.3937 inch.
Millimeter.....	1-1000th of a meter.	.0394 inch.

MEASURES OF SURFACE

DENOMINATIONS AND VALUES		EQUIVALENTS IN USE
Hectare.....	10,000 square meters.	2.471 acres.
Are.....	100 square meters.	119.6 square yards.
Centare.....	1 square meter.	1,550. square inches

MEASURES OF VOLUME

DENOMINATIONS AND VALUES			EQUIVALENTS IN USE	
NAMES	No. of Liters	CUBIC MEASURES	DRY MEASURE	WINE MEASURE
Kiloliter or stere.....	1,000	1 cubic meter.	1.308 cubic yards.	264.17 gallons.
Hectoliter.....	100	1-10th cubic meter.	2 bu. and 3.35 pecks.	26.417 gallons.
Dekaliter.....	10	10 cubic decimeters.	9.08 quarts.	2.6417 gallons.
Liter.....	1	1 cubic decimeter.	.908 quart.	1.0567 quarts.
Deciliter.....	1-10	1-10th cubic decimeter.	6.1023 cubic inches.	.845 gill.
Centiliter.....	1-100	10 cubic centimeters	.6102 cubic inch.	.338 fluid oz.
Milliliter.....	1-1000	1 cubic centimeter.	.061 cubic inch.	.27 fl. drm.

WEIGHTS

DENOMINATIONS AND VALUES			EQUIVALENTS IN USE
NAMES	Number of Grams	WEIGHT OF VOLUME OF WATER AT ITS MAXIMUM DENSITY	AVOIRDUPOIS WEIGHT
Millier or Tonneau.....	1,000,000	1 cubic meter.	2204.6 pounds.
Quintal.....	100,000	1 hectoliter.	220.46 pounds.
Myriagram.....	10,000	10 liters.	22.046 pounds.
Kilogram or Kilo.....	1,000	1 liter.	2.2046 pounds.
Hectogram.....	100	1 deciliter.	3.5274 ounces.
Dekagram.....	10	10 cubic centimeters.	.3527 ounce.
Gram.....	1	1 cubic centimeter.	15.432 grains.
Decigram.....	1-10	1-10th of a cubic centimeter.	1.5432 grain.
Centigram.....	1-100	10 cubic millimeters.	.1543 grain.
Milligram.....	1-1000	1 cubic millimeter.	.0154 grain.

For measuring surfaces, the square dekameter is used under the term of ARE; the hectare, or 100 ares, is equal to about $2\frac{1}{2}$ acres. The unit of capacity is the cubic decimeter or LITER, and the series of measures is formed in the same way as in the case of the table of lengths. The cubic meter is the unit of measure for solid bodies, and is termed STERE. The unit of weight is the GRAM, which is the weight of one cubic centimeter of pure water weighed in a vacuum at the temperature of 4 deg. Cent. or 39.2 deg. Fahr., which is about its temperature of maximum density. In practice, the term cubic centimeter, abbreviated c.c., is generally used instead of milliliter, and cubic meter instead of kiloliter.

THE CONVERSION OF FRENCH (METRIC) INTO ENGLISH MEASURE

1 cubic centimeter	=	17 minims			
2 cubic centimeters	=	34 "			
3 "	=	51 "			
4 "	=	68 "	or 1 dram	8 minims	
5 "	=	85 "	" 1 "	25 "	
6 "	=	101 "	" 1 "	41 "	
7 "	=	118 "	" 1 "	58 "	
8 "	=	135 "	" 2 drams	15 "	
9 "	=	152 "	" 2 "	32 "	
10 "	=	169 "	" 2 "	49 "	
20 "	=	338 "	" 5 "	38 "	
30 "	=	507 "	" 1 ounce	0 dram	27 minims
40 "	=	676 "	" 1 "	3 drams	16 "
50 "	=	845 "	" 1 "	6 "	5 "
60 "	=	1014 "	" 2 ounces	0 "	54 "
70 "	=	1183 "	" 2 "	3 "	43 "
80 "	=	1352 "	" 2 "	6 "	32 "
90 "	=	1521 "	" 3 "	1 "	21 "
100 "	=	1690 "	" 3 "	4 "	10 "
1000 "	=	1 liter =	35 "	1 "	40 "

THE CONVERSION OF FRENCH (METRIC) INTO ENGLISH WEIGHT

The following table, which contains no error greater than one-tenth of a grain, will suffice for most practical purposes.

1 gram	=	15 $\frac{2}{5}$ grains.			
2 grams	=	30 $\frac{4}{5}$ "			
3 "	=	46 $\frac{1}{5}$ "			
4 "	=	61 $\frac{4}{5}$ "or	1 dram	14 $\frac{4}{5}$ grain
5 "	=	77 $\frac{1}{5}$ "	1 "	17 $\frac{1}{5}$ grains
6 "	=	92 $\frac{3}{5}$ "	1 "	32 $\frac{3}{5}$ "
7 "	=	108 "	1 "	48 "
8 "	=	123 $\frac{2}{5}$ "	2 drams	3 $\frac{2}{5}$ "
9 "	=	138 $\frac{4}{5}$ "	2 "	18 $\frac{4}{5}$ "
10 "	=	154 $\frac{2}{5}$ "	2 "	34 $\frac{2}{5}$ "
11 "	=	169 $\frac{4}{5}$ "	2 "	49 $\frac{4}{5}$ "
12 "	=	185 $\frac{1}{5}$ "	3 "	5 $\frac{1}{5}$ "
13 "	=	200 $\frac{3}{5}$ "	3 "	20 $\frac{3}{5}$ "
14 "	=	216 "	3 "	36 "
15 "	=	231 $\frac{2}{5}$ "	3 "	51 $\frac{2}{5}$ "
16 "	=	247 "	4 "	7 "
17 "	=	262 $\frac{2}{5}$ "	4 "	22 $\frac{2}{5}$ "
18 "	=	277 $\frac{4}{5}$ "	4 "	37 $\frac{4}{5}$ "
19 "	=	293 $\frac{1}{5}$ "	4 "	53 $\frac{1}{5}$ "
20 "	=	308 $\frac{3}{5}$ "	5 "	8 $\frac{3}{5}$ "
30 "	=	463 "	7 "	43 "
40 "	=	617 $\frac{1}{5}$ "	10 "	17 $\frac{1}{5}$ "
50 "	=	771 $\frac{3}{5}$ "	12 "	51 $\frac{3}{5}$ "
60 "	=	926 "	15 "	26 "
70 "	=	1080 $\frac{1}{5}$ "	18 "	0 $\frac{1}{5}$ "
80 "	=	1234 $\frac{3}{5}$ "	20 "	34 $\frac{3}{5}$ "
90 "	=	1389 "	23 "	9 "
100 "	=	1543 $\frac{1}{5}$ "	25 "	43 $\frac{1}{5}$ "
1000 "	=	1 kilogram	=	32 oz., 1 dr., 12 $\frac{2}{5}$ gr.	

THE ELEMENTS:
THEIR NAMES, SYMBOLS, AND ATOMIC WEIGHTS
OXYGEN STANDARD.

Compiled by HENRY F. RAESS.

1915					
Aluminum...Al	27.10	Holmium....Ho	163.50	Rhodium....Rh	102.90
Antimony..Sb	120.20	Hydrogen...H	1.008	Rubidium...Rb	85.45
Argon.....A	39.88	Indium.....In	114.80	Ruthenium..Ru	101.70
Arsenic...As	74.96	Iodine.....I	126.92	Samarium...Sa	150.40
Barium...Ba	137.37	Iridium.....Ir	193.10	Scandium...Sc	44.10
Bismuth...Bi	208.00	Iron.....Fe	55.84	Selenium...Se	79.20
Boron.....B	11.00	Krypton....Kr	82.92	Silicon.....Si	28.30
Bromine...Br	79.92	Lanthanum..La	139.00	Silver.....Ag	107.88
Cadmium...Cd	112.40	Lead.....Pb	207.10	Sodium.....Na	23.00
Caesium...Cs	132.81	Lithium....Li	6.94	Strontium...Sr	87.63
Calcium...Ca	40.07	Lutecium...Lu	174.00	Sulphur....S	32.07
Carbon...C	12.00	Magnesium..Mg	24.32	Tantalum...Ta	181.50
Cerium...Ce	140.25	Manganese..Mn	54.93	Tellurium..Te	127.50
Chlorine...Cl	35.46	Mercury....Hg	200.60	Terbium...Tb	159.20
Chromium..Cr	52.00	Molybdenum.Mo	96.00	Thallium...Tl	204.00
Cobalt....Co	58.97	Neodymium..Nd	144.30	Thorium...Th	232.40
Columbium.Cb	93.50	Neon.....Ne	20.20	Thulium...Tm	168.50
Copper....Cu	63.57	Nickel.....Ni	58.68	Tin.....Sn	119.00
Dysprosium Dy	162.50	Niton.....Nt	222.40	Titanium...Ti	48.10
Erbium....Er	167.70	Nitrogen...N	14.01	Tungsten...W	184.00
Europium..Eu	152.00	Osmium....Os	190.90	Uranium...U	238.50
Fluorine...F	19.00	Oxygen.....O	16.00	Vanadium...V	51.00
Gadolinium.Gd	157.30	Palladium..Pd	106.70	Xenon.....Xe	130.20
Gallium...Ga	69.90	Phosphorus.P	31.04	Ytterbium..Yb	173.50
Germanium.Ge	72.50	Platinum...Pt	195.20	Yttrium...Yt	89.00
Glucium...Gl	9.10	Potassium..K	39.10	Zinc.....Zn	65.37
Gold.....Au	197.20	PraseodymiumPr	140.60	Zirconium..Zr	90.60
Helium....He	3.96	Radium.....Ra	226.40		

TABLE OF COMPARATIVE PLATE SPEED
NUMBERS

H & D	Watkins P No.	Wynne F No	H & D	Watkins P No.	Wynne F No.
10	15	24	220	323	114
20	30	28	240	352	120
40	60	49	260	382	124
80	120	69	280	412	129
100	147	77	300	441	134
120	176	84	320	470	138
140	206	91	340	500	142
160	235	103	380	558	150
200	294	109	400	588	154

The above Watkins and Wynne numbers are equivalent to the H and D, only when the latter is determined in accordance with the directions of Hurter and Driffield, that is with pyro-soda developer and using the straight portion only of the density curve.

To convert H and D into Watkins: Multiply H and D by 50 and divide by 34. For all practical purposes the Watkins P number is $1\frac{1}{2}$ times H and D.

To convert Watkins into Wynne F Nos.: Extract the square root and multiply by 6.4.

The above methods have been approved by the Watkins Meter Company and the Infalible Exposure Meter Company.

**TABLE OF SOLUBILITIES OF THE MORE COMMON CHEMICALS
USED IN PHOTOGRAPHY**

Sol.—Soluble. V.S.—Very Soluble. S.S.—Slightly Soluble.
Dec.—Decomposed. Insol.—Insoluble.

One Part is Soluble
in—Parts of Water

One Part is Soluble
in—Parts of Water

	Cold	Hot		Cold	Hot
Acetone, Sulphite...	1	..	Potassium, Bicarbonate.....	3.5	Dec.
Acid, Citric.....	0.75	0.50	Potassium, Bichromate.....	10	1
Acid, Gallic.....	100	0.3	Potassium, Bromide.....	1.5	1
Acid, Oxalic.....	9	0.3	Potassium, Carbonate.....	.9	0.50
Acid, Pyrogallic.....	2	V.S.	Potassium, Chloroplatinite.....	6	V.S.
Acid, Tannic.....	0.6	..	Potassium, Cyanide.....	1	0.5
Acid, Tartaric.....	0.75	.5	Potassium, Ferricyanide.....	2.5	1.3
Alum.....	8	.25	Potassium, Ferrocyanide.....	3	1.5
Alum, Chrome.....	6	Dec.	Potassium, Iodide...	0.75	0.5
Aluminum, Chloride.....	0.25	V.S.	Potassium, Metabisulphite.....	Sol.	Dec.
Amidol.....	4	V.S.	Potassium, Oxalate..	3	2
Ammonium, Bichromate.....	5	.25	Potassium, Permanganate.....	16	10
Ammonium, Bromide.....	1.3	0.7	Potassium, Persulphate.....	50	Dec.
Ammonium, Carbonate.....	4	Dec.	Potassium, Sulphocyanide.....	1	0.5
Ammonium, Citrate.....	0.5	V.S.	Pyrocatechin.....	1.25	V.S.
Ammonium, Iodide..	0.75	V.S.	Rochelle Salt.....	1.5	V.S.
Ammonium, Nitrate.....	1	V.S.	Silver, Nitrate.....	.75	.25
Ammonium, Persulphate.....	1.5	Dec.	Sodium, Acetate...	3	.5
Ammonium, Sulphocyanide.....	0.6	V.S.	Sodium, Bicarbonate	12	Dec.
Borax.....	12.5	2	Sodium, Bisulphite..	V.S.	..
Cadmium, Bromide..	1	V.S.	Sodium, Bromide...	1.25	1
Cadmium, Chloride..	0.7	V.S.	Sodium, Carbonate (dry).....	6	2.2
Cadmium, Iodide...	1	.75	Sodium, Carbonate (crys't).....	1.5	V.S.
Caustic Potash—Pot. Hydrate.....	0.5	.25	Sodium, Chloride...	3	2.5
Caustic Soda—Soda Hydrate.....	1.5	.5	Sodium, Citrate....	1	.5
Copper, Chloride....	1	.75	Sodium, Hyposulphite.....	1.5	1
Copper, Sulphate... 3	1	5	Sodium, Iodide.....	.5	.3
Edinol.....	1	5	Sodium, Phosphate..	6.7	1
Gold, Chloride.....	V.S.	V.S.	Sodium, Sulphide... V.S.	V.S.	V.S.
Hydroquinone.....	17	..	Sodium, Sulphite (dry).....	4	2
Ferric, Chloride....	0.75	.5	Sodium, Sulphite (crys't).....	2.2	1
Ferric, Amm. Citrate.....	4	..	Sodium, Tungstate..	8-12	S.
Ferric, Potassium Oxalate.....	15	0.85	Uranium, Chloride..	V.S.	V.S.
Ferric, Sodium Oxalate.....	1.69	0.55	Uranium, Nitrate... .5	.5	.25
Ferrous, Sulphate... 1.5	.05	..	Uranium, Sulphate.. .5	.5	.25
Ferrous, Oxalate... Insol.			
Lead, Acetate.....	2	1			
Lead, Nitrate.....	2	.7			
Mercury, Bichloride.....	18	2			
Metol.....	Sol.	Sol.			
Ortol.....	Sol.	Sol.			



Mabel Cox Surdam.

**TABLE FOR CALCULATING DISTANCES IN ENLARGING OR
REDUCING**

From The British Journal Photographic Almanac

Focus of Lens	Times of Enlargement and Reduction							
	1 Inch	2 Inch- es	3 Inch- es	4 Inch- es	5 Inch- es	6 Inch- es	7 Inch- es	8 Inch- es
2.....	4 4	6 3	8 2 $\frac{2}{3}$	10 2 $\frac{1}{2}$	12 2 $\frac{2}{5}$	14 2 $\frac{1}{3}$	16 2 $\frac{2}{7}$	18 2 $\frac{1}{4}$
2 $\frac{1}{2}$	5 5	7 $\frac{1}{2}$ 3 $\frac{3}{4}$	10 3 $\frac{1}{3}$	12 $\frac{1}{2}$ 3 $\frac{1}{8}$	15 3	17 $\frac{1}{2}$ 2 $\frac{9}{10}$	20 2 $\frac{6}{7}$	22 $\frac{1}{2}$ 2 $\frac{3}{16}$
3.....	6 6	9 4 $\frac{1}{2}$	12 4	15 3 $\frac{3}{4}$	18 3 $\frac{2}{5}$	21 3 $\frac{1}{2}$	24 3 $\frac{2}{7}$	27 3 $\frac{3}{8}$
3 $\frac{1}{2}$	7 7	10 $\frac{1}{2}$ 5 $\frac{1}{4}$	14 4 $\frac{2}{3}$	17 $\frac{1}{2}$ 4 $\frac{3}{4}$	21 4 $\frac{1}{5}$	24 $\frac{1}{2}$ 4 $\frac{1}{12}$	28 4	31 $\frac{1}{2}$ 3 $\frac{9}{10}$
4.....	8 8	12 6	16 5 $\frac{1}{3}$	20 5	24 4 $\frac{2}{5}$	28 4 $\frac{2}{3}$	32 4 $\frac{1}{7}$	36 4 $\frac{1}{2}$
4 $\frac{1}{2}$	9 9	13 $\frac{1}{2}$ 6 $\frac{3}{4}$	18 6	22 $\frac{1}{2}$ 5 $\frac{3}{5}$	27 5 $\frac{2}{5}$	31 $\frac{1}{2}$ 5 $\frac{1}{4}$	36 5 $\frac{1}{7}$	40 $\frac{1}{2}$ 5 $\frac{1}{16}$
5.....	10 10	15 7 $\frac{1}{2}$	20 6 $\frac{2}{3}$	25 6 $\frac{1}{4}$	30 6	35 5 $\frac{5}{6}$	40 5 $\frac{5}{7}$	45 5 $\frac{5}{8}$
5 $\frac{1}{2}$	11 11	16 $\frac{1}{2}$ 8 $\frac{1}{4}$	22 7 $\frac{1}{3}$	27 $\frac{1}{2}$ 6 $\frac{4}{5}$	33 6 $\frac{1}{2}$	38 $\frac{1}{2}$ 6 $\frac{5}{12}$	44 6 $\frac{2}{7}$	49 $\frac{1}{2}$ 6 $\frac{9}{16}$
6.....	12 12	18 9	24 8	30 7 $\frac{1}{2}$	36 7 $\frac{1}{5}$	42 7	48 6 $\frac{2}{7}$	54 6 $\frac{3}{4}$
7.....	14 14	21 10 $\frac{1}{2}$	28 9 $\frac{1}{3}$	35 8 $\frac{3}{4}$	42 8 $\frac{2}{5}$	49 8 $\frac{1}{6}$	56 8	63 7 $\frac{7}{8}$
8.....	16 16	24 12	32 10 $\frac{2}{3}$	40 10	48 9 $\frac{3}{5}$	56 9 $\frac{1}{3}$	64 9 $\frac{1}{7}$	72 9
9.....	18 18	27 13 $\frac{1}{2}$	36 12	45 11 $\frac{1}{4}$	54 10 $\frac{2}{5}$	63 10 $\frac{1}{2}$	72 10 $\frac{2}{7}$	81 10 $\frac{1}{8}$

The object of this table is to enable any manipulator who is about to enlarge (or reduce) a copy any given number of times to do so without troublesome calculation. It is assumed that the photographer knows exactly what the focus of his lens is, and that he is able to measure accurately from its optical center. The use of the table will be seen from the following illustration: A photographer has a *carte* to enlarge to four times its size, and the lens he intends employing is one of 6 inches equivalent focus. He must therefore look for 4 on the upper horizontal line and for 6 on the first vertical column and carry his eye to where these two join, which will be 30-7 $\frac{1}{2}$. The greater of these is the distance the sensitive plate must be from the center of the lens; and the lesser, the distance of the picture to be copied. To *reduce* a picture any given number of times, the same method must be followed; but in this case the greater number will represent the distance between the lens and the picture to be copied, the latter that between the lens and the sensitive plate. This explanation will be sufficient for every case of enlargement or reduction.

If the focus of the lens be 12 inches, as this number is not in the column of focal lengths, look out for 6 in this column and multiply by 2, and so on with any other numbers.

**TABLES OF DISTANCES AT AND BEYOND WHICH ALL OBJECTS
ARE IN FOCUS WHEN SHARP FOCUS IS SECURED ON
INFINITY**

Focal Length of Lens in Inches	Ratio marked on Stops													
	f/4	f/5.6	f/6	f/7	f/8	f/10	f/11	f/15	f/16	f/20	f/22	f/32	f/44	f/64
	Number of feet after which all is in focus													
4	33	24	22	19	17	13	12	9	8	7	6	4	3	2
4¼	38	27	25	21	19	15	14	10	10	7	7	5	3½	2½
4½	42	30	28	24	21	17	15	11	11	8½	7½	5	4	3
4¾	47	34	31	27	24	19	17	12	12	9½	8½	6	5	3
5	52	36	35	30	26	21	19	14	13	10½	9½	6½	5½	3½
5¼	57	40	38	33	28	23	21	15	14	11½	10½	7	5½	3½
5½	63	45	43	36	31	25	23	17	15	12½	11½	7½	6	4
5¾	68	50	46	38	34	27	25	18	17	13½	13	8½	6½	4
6	75	54	50	42	38	30	28	20	19	15	14	9	7	4½
6¼	81	58	54	46	40	32	29	22	20	16	15	10	7½	5
6½	87	62	58	50	44	35	32	23	22	17½	16	11	8	5½
6¾	94	67	63	54	47	38	34	25	24	19	17	12	8½	6
7	101	72	68	58	51	40	37	27	25	20	18	12½	9	6
7¼	109	78	73	62	54	44	39	29	27	22	20	13½	10	6½
7½	117	83	78	64	58	47	42	31	29	24	21	14½	10½	7
7¾	124	90	83	71	62	50	45	33	31	25	22	15½	11	7½
8	132	96	88	76	68	52	48	36	32	28	24	16	12	8
8¼	141	100	94	80	71	56	51	37	35	29	25	17½	12½	8½
8½	150	104	100	84	76	60	56	40	38	30	27	19	13½	9
8¾	156	111	104	89	78	63	57	42	39	32	29	20	14	10
9	168	120	112	96	84	67	61	45	42	34	31	21	15	10½
9¼	180	127	116	101	90	71	65	47	45	35	32	22	16	11
9½	190	133	125	107	95	75	68	50	47	37	34	24	17	12
9¾	197	141	131	113	99	79	72	52	50	39	36	25	18	12½
10	208	148	140	120	104	83	75	55	52	42	38	26	19	13

If sharp focus is secured on any of the distances shown, then, with the stop indicated all objects are in focus from half the distance focused on up to infinity.

**LENGTH OF STUDIO
REQUIRED FOR LENSES OF DIFFERENT FOCAL LENGTHS
FROM 6 TO 8 FEET IS ALLOWED FOR THE CAMERA AND
OPERATOR**

From "Photographic Lenses" by BECK and ANDREWS

Focus of Lens	Size	Kind of Portrait	Length of Studio	Dist. of Lens from Object
Inches			In Feet	In Feet
6	Carte de Visite 3¼x4¼.....	Full Length	18 to 20	11 to 12
7½	Carte de Visite.....	Full Length	22 to 25	14 to 15
		Full Length	24 to 28	17 to 19
8½	Carte de Visite.....	Bust	10 to 15	5
		Full Length	20 to 23	12 to 13
9½	Cabinet and smaller groups.....	Bust	12 to 17	7
		Full Length	25 to 30	17 to 18
11	Cabinet and 5x7 groups.....	Bust	13 to 20	8
14½	Cabinets, panels and 6½x8½ groups.....	Full Length	32 to 40	23 to 24
		Bust	14 to 20	7
		Full Length	20 to 25	13
19	10x12 portraits or groups.....	Bust	14 to 20	7
		Full Length	25 to 30	14
24	16x20 portraits or groups.....	Bust	14 to 20	8

"UNIFORM SYSTEM" NUMBERS FOR STOPS FROM

$$\frac{f}{1} \text{ TO } \frac{f}{100}$$

In the following table Mr. S. A. Warburton calculated the exposure necessary with every stop from $\frac{f}{1}$ to $\frac{f}{100}$ compared with the unit stop of the "uniform system" of the Photographic Society of Great Britain. The figures which are underlined show in the first column what $\frac{f}{a}$ must be in order to increase the exposure in geometrical ratio from $\frac{f}{4}$, the intermediate numbers showing the uniform system number for any other aperture.

f	U. S. No.	f	U. S. No.	f	U. S. No.
<u>1</u>	<u>$\frac{1}{16}$</u>	15	14.06	58	210.25
$1\frac{1}{4}$.097	16	16	59	217.56
<u>1.414</u>	<u>$\frac{1}{8}$</u>	17	18.06	60	225.00
$1\frac{1}{2}$.140	18	20.25	61	232.56
$1\frac{3}{4}$.191	19	22.56	62	240.25
<u>2</u>	<u>$\frac{1}{4}$</u>	20	25.00	63	248.06
$2\frac{1}{4}$.316	21	27.56	64	256
$2\frac{1}{2}$.390	22	30.25	65	264.06
<u>2.828</u>	<u>$\frac{1}{2}$</u>	22.62	32	66	272.25
$2\frac{3}{4}$.472	23	33.06	67	280.56
3	.562	24	36.00	68	289.00
$3\frac{1}{4}$.660	25	39.06	69	297.56
$3\frac{1}{2}$.765	26	42.25	70	306.25
$3\frac{3}{4}$.878	27	45.56	71	315.06
<u>4</u>	<u>1</u>	28	49.00	72	324.00
$4\frac{1}{4}$	1.12	29	52.56	73	333.06
$4\frac{1}{2}$	1.26	30	56.25	74	342.25
$4\frac{3}{4}$	1.41	31	60.06	75	351.56
5	1.56	32	64	76	361.00
$5\frac{1}{4}$	1.72	33	68.06	77	370.56
$5\frac{1}{2}$	1.89	34	72.25	78	380.25
<u>5.656</u>	<u>2</u>	35	76.56	79	390.06
$5\frac{3}{4}$	2.06	36	81.00	80	400.00
6	2.25	37	85.56	81	410.06
$6\frac{1}{4}$	2.44	38	90.25	82	420.25
$6\frac{1}{2}$	2.64	39	95.06	83	430.56
$6\frac{3}{4}$	2.84	40	100.00	84	440.00
7	3.06	41	105.06	85	451.56
$7\frac{1}{4}$	3.28	42	110.25	86	462.25
$7\frac{1}{2}$	3.51	43	115.56	87	473.06
$7\frac{3}{4}$	3.75	44	121.00	88	484.00
<u>8</u>	<u>4</u>	45	126.56	89	495.06
$8\frac{1}{4}$	4.25	45.25	128	90	506.25
$8\frac{1}{2}$	4.51	46	132.25	90.50	512
$8\frac{3}{4}$	4.78	47	138.06	91	517.56
9	5.06	48	144.00	92	529.00
$9\frac{1}{4}$	5.34	49	150.06	93	540.56
$9\frac{1}{2}$	5.64	50	156.25	94	552.25
$9\frac{3}{4}$	5.94	51	162.56	95	564.06
10	6.25	52	169.00	96	576.00
11	7.56	53	175.56	97	588.06
<u>11.31</u>	<u>8</u>	54	182.25	98	600.25
12	9.00	55	189.06	99	612.56
13	10.56	56	196.00	100	625
14	12.25	57	203.06		

American Photographic Societies

This list is compiled from information received from an inquiry form sent to the societies during the latter half of 1919. It includes many societies not given in the 1919 Annual, but falls short of completeness as a record of the photographic societies of America. Secretaries of societies not here listed are urged to send us particulars of their organization so that the list may be fully representative of society activities.—Editor.

- AMERICAN INSTITUTE PHOTOGRAPHIC SECTION—New York City. Headquarters, 322-324 West 23d Street. Established March 26, 1859. Stated meetings, first and third Mondays of each month. No meetings during Summer months. *Chairman*, Oscar G. Mason; *Vice-Chairman*, Robert A. B. Dayton; *Treasurer*, James Y. Watkins; *Secretary*, John W. Bartlett, M.D., F.R.P.S., 149 West 94th Street.
- ASSOCIATED CAMERA CLUBS OF AMERICA—Headquarters, 878-880 Broad Street, Newark, N. J. *President*, Julius F. Graether, Newark Camera Club; *Secretary*, Louis F. Bucher, Newark Camera Club; *Treasurer*, Henry C. Brewster, Newark Camera Club; *Western Vice-President*, Todd Hazen Oregon Camera Club; *Southern Vice-President*, George H. Rowe, Photographic Club of Baltimore; *Central Vice-President*, Dr. Maclay Lyon, Kansas City Camera Club; *Eastern Vice-President*, J. L. Hanna, Columbia Photographic Society, Philadelphia. Motive—Closer affiliation of Camera Clubs, Annual Exhibits, Interchanges of Prints and Slides, as well as ideas, and literature. Membership September 1, twelve clubs. Association organized May 1, 1919.
- BOSTON CAMERA CLUB—Boston, Mass. Established 1881. Incorporated 1886. Membership, 75. *President*, P. Hubbard; *Secretary*, John H. Thurston, 50 Bromfield Street.
- BOSTON PHOTO CLAN—Organized July, 1911. Headquarters, The Garo Studio, 739 Boylston Street. Membership 9.
- BOSTON YOUNG MEN'S CHRISTIAN UNION CAMERA CLUB—Boston, Mass. Headquarters, 48 Boylston Street, Boston. Organized 1908. *President*, Merton L. Vincent; *Vice-President*, William E. Howard; *Treasurer*, C. E. Dodge; *Secretary*, Harold E. Almy. Meetings first Tuesday each month at club rooms, 48 Boylston Street.
- BUFFALO CAMERA CLUB—Buffalo, N. Y. Headquarters, Kinne Building, corner Main and Utica Streets. Annual election of officers, fourth Thursday in April; regular meeting nights, second and fourth Tuesdays of each month. *President*, F. W. Cowell; *Vice-President*, N. G. Sherk; *Secretary*, Charles L. Peck, 1101 Elmwood Avenue. Member Associated Camera Clubs of America.
- CALIFORNIA CAMERA CLUB—San Francisco, Cal. Headquarters, 833 Market Street, San Francisco. Established March 18, 1890. Incorporated April 5, 1890. Membership 408. Date of meeting, second Tuesday, monthly. Monthly print exhibitions. *President*, Dr. Edward G. Eisen. *Secretary*, J. H. Hornell. Members of other camera clubs are cordially invited to visit our rooms when in San Francisco.
- CAMERA CLUB—New York. Headquarters, 121 West 68th Street. Established by consolidation of Society of Amateur Photographers and New York Camera Club in April, 1896. Incorporated May 7, 1896. Membership 200. Date of annual meeting, first Thursday after the first Monday in January. *Secretary*, Monroe W. Tingley.
- CAMERA CLUB OF DETROIT—Detroit, Mich. Organized April, 1915. Membership, 30 (active). Annual meeting for election of officers, first Monday in October. *Secretary*, Dr. Oscar E. Fischer, 507 Field Avenue, Detroit.
- CAMERA CLUB OF HARTFORD—Hartford, Conn. Membership, 15. *President*, Dr. Frederic S. Crossfield, 75 Pratt Street; *Vice-President*, Clayton P. Chamberlain; *Corresponding Secretary*, Eugene D. Field; *Treasurer*, A. L. Chase; *Secretary*, Charles R. Nason, 224 Oxford Street. Member Associated Camera Clubs of America.
- CAMERA CLUB OF THE TWENTY-THIRD STREET BRANCH, Y. M. C. A.—New York. Headquarters, 23d Street Y. M. C. A. Established June 3, 1904. Membership, 65. Date of business meetings, second Tuesday in each month. *President*, Wm. J. Guy; *Acting Secretary*, Ernest A. Heckler, 215 West 23d Street; *Treasurer*, F. W. Grunwald. Date of annual exhibition, usually in January. No fixed date.

- "CAMERADS"—New Brunswick, N. J. Headquarters, corner Church and George Streets. Established April 24, 1890. *Secretary*, Harvey Iredell, D.D.S., Lock Box 34, New Brunswick.
- CAMERA PICTORIALISTS OF LOS ANGELES—Los Angeles, Cal. Headquarters, Room 31, Walker Auditorium. Association formed for strictly pictorial work; the holding of an annual International Salon; and for the good of the cause generally. Membership limited to fifteen. Meetings, first Monday of month. *Director*, Louis Fleckenstein; *Secretary*, Ernest Williams.
- CAPITAL CAMERA CLUB, INC.—Washington, D. C., 712 11th Street, N. W. Founded May 1, 1891. Annual meeting, first Thursday in May. *President*, Frederick L. Pittman; *Vice-President*, Lieut. F. H. Chant; *Secretary*, Carl H. Kattelmann; *Treasurer*, Thos. B. Gardner; *Librarian*, Miss Lucy Powell. Date of annual exhibition, March.
- CENTRAL Y. M. C. A. CAMERA CLUB—Headquarters, 1421 Arch Street, Philadelphia, Pa. Club organized 22 years ago. Meetings, third Monday in month. *President*, Bernard B. Wolff; *Vice-Presidents*, Geo. D. Gassner, J. F. Jackson; *Secretary*, S. K. Taylor; *Financial Secretary*, W. S. Snyder. Membership, 90.
- CHICAGO CAMERA CLUB—Chicago, Ill. Headquarters, 31 W. Lake Street. Established February 14, 1904. Incorporated February 19, 1904. Date of meetings, every Wednesday. *President*, W. F. Wiencke; *Vice-President*, J. J. Ryan; *Secretary*, E. L. MacMillan; *Treasurer*, W. J. Becker. Member of Associated Camera Clubs of America.
- CHICAGO PHOTO FELLOWS—Chicago, Ill. Organized September 8, 1909. Membership, 8. *Correspondent*, F. M. Tuckerman, 1109 Railway Exchange, Chicago.
- CITY HALL CAMERA CLUB—Los Angeles, Cal. Headquarters, Room 502, Hosfield Building. Organized May 25, 1914. Membership, 24. *Correspondent*, W. C. Sawyer.
- CLEVELAND PHOTOGRAPHIC SOCIETY—Cleveland, Ohio, 412 Superior Avenue, N. W. Established June 7, 1913. Permanent organization effected at meeting of June 18. Meetings every Wednesday. *Chairman*, Geo. Cook; *Secretary-Treasurer*, H. L. Porter. Member Associated Camera Clubs of America.
- COLUMBIA PHOTOGRAPHIC SOCIETY—Philadelphia, Pa. Headquarters, 2526 North Broad Street, Philadelphia. Established 1889. Incorporated July 3, 1894. Membership, 80. Business meeting first Monday of each month; other Mondays, lectures or demonstrations. Member of Associated Camera Clubs of America. *President*, Daniel Fritz; *Vice-President*, Theo. D. Mitchell; *Treasurer*, C. F. Davis, 701 Eldridge Avenue, West Collinswood, N. J.; *Secretary*, Harry R. Till, 6103 N. Warnock Street, Philadelphia, Pa.
- DARTMOUTH CAMERA CLUB—Headquarters, 7-8 Robinson Hall, Hanover, N. H. Organized, 1915. Membership, 28. *President*, K. D. Smith; *Vice-President*, C. Le Boutillier; *Treasurer*, S. Adams; *Secretary*, A. R. Steiner. All communications addressed to Prof. Leland Griggs, Hanover, N. H.
- ELMIRA CAMERA CLUB—Elmira, N. Y. Headquarters, 116 Baldwin Street, Elmira. Established 1902. Membership, 30. Meets first Wednesday each month. *President*, C. G. Leonardi; *Secretary-Treasurer*, E. Radeker Stancliff, 240 Lake Street. Member Associated Camera Clubs of America.
- ELYSIAN CAMERA CLUB—Hoboken, N. J. Headquarters, 307 Washington Street. Established 1902. Date of meetings, second Friday of each month. Membership, 50. *President*, Martin S. Crane; *Vice-President*, Adolph Geiger; *Treasurer*, Julius Nelson; *Secretary*, William F. Nelson, 590 Boulevard East, Weehawken, N. J. Member Associated Camera Clubs of America.
- ESSEX CAMERA CLUB—Newark, N. J. Headquarters, 872 Broad Street, Newark, N. J. Organized July, 1899. Membership, 40. Date of meetings, fourth Tuesday of every month. *President*, George A. Hardy; *Secretary*, L. F. Gebhardt, South 11th Street.
- GILD OF PHOTOGRAPHERS OF THE SOCIETY OF ARTS AND CRAFTS of Boston, Mass. *Dean*, Mr. John Murdoch; *Secretary and Treasurer*, Miss Amelia Muir Baldwin, 22 River Street, Boston; *Councillors*, Mr. John Murdoch, Miss Florence Maynard, Miss Helen M. Murdoch. Organized February 18th, 1916. Meetings held at members' studios.
- GRAND RAPIDS CAMERA CLUB—Headquarters, 2 Central Place, where demonstrations and inspiration meetings are held each Thursday evening from September to June inclusive, with occasional Field Days during the summer months. *President*, H. M. Kurtzworth; *Vice-President*, Dr. A. Williams; *Second Vice-President*, Miss Vera Bennett; *Treasurer*, Mrs. Chas. Allvin; *Secretary*, Miss Loa G. Winegar. Member Associated Camera Clubs of America.

INTERNATIONAL PHOTOGRAPHIC ASSOCIATION—San Francisco, Cal. Founded 1908. *President*, F. B. Hinman, Evergreen, Col.; *Chief Album Director*, J. H. Winchell, R. F. D. No. 2 Painesville, Ohio; *General Secretary*, Fayette J. Clute, 413-415 Claus Spreckels Building, San Francisco; *Stereoscopic Album Director*, James B. Warner, 413-415 Claus Spreckels Building, San Francisco, Cal.; *Director Post Card Division*, John Bieseman, Hemlock, Ohio; *Director Lantern-Slide Eastern Division*, Arthur H. Farrow, 51 Richelieu Terrace, Newark, N. J.; *Director Lantern-Slide Western Division*, A. E. Davies, 1327 Grove Street, Berkeley, Cal. The *State Secretaries*: Alabama—Richard Hines, Jr., Barton Academy Building, Mobile. California—W. E. Thomson, 3211 School Street, Fruitvale, Cal. Colorado—O. E. Aultman, Pested Building, Trinidad. Florida—Capt. E. S. Coutant, Box 73, Stuart. Georgia—L. O. Surles, P. O. Box 434, Cuthbert. Idaho—Eugene Clifford, 902 9th Avenue, Lewiston. Illinois—George A. Price, Box 286, Champaign. Indiana—H. E. Bishop, 551 East 40th Street, Indianapolis. Iowa—C. W. Parker, Mapleton. Maryland—E. G. Hopper, 218 East 20th Street, Baltimore. Massachusetts—John Mardon, 10 High Street, Boston. Michigan—W. E. Ziegenfuss, M.D., 171 Richton Street, Detroit. Minnesota—Leonard A. Williams, 622 2nd Avenue South, St. Cloud. Mississippi—George W. Askew, Jr., 211 34th Avenue Meridian. Missouri—Wharton Schooler, R. F. D. No. 2, Eolia. New Hampshire—Mrs. A. Leonora Kellogg, Box 224, Londonberry. New York—Charles F. Rice, P. O. Box 517, Mamaroneck. New Jersey—Arthur H. Farrow, 51 Richelieu Terrace, Newark. North Dakota—Jas. A. Van Kleeck, 619 Second Avenue, North Fargo. Ohio—J. H. Winchell, R. F. D. No. 2, Painesville. Pennsylvania—L. A. Sncary, 2822 Espy Avenue, Pittsburgh. South Dakota—C. B. Bolles, L. B., 351, Aberdeen. Texas—J. B. Oheim, P. O. Drawer M, Henrietta. Utah—John C. Swenson, A.B., Provo. West Virginia—William E. Monroe, Box 298, Point Pleasant.

I. P. A. LANTERN SLIDE INTERCHANGE—Under the auspices of "Camera Craft" (San Francisco, Cal.) Address all communications to Arthur H. Farrow, *Director*, 51 Richelieu Terracc, Newark, N. J.

KANSAS CITY CAMERA CLUB—1919-1920. Suite 501, Bryant Building, Kansas City, Mo. Organized 1914. Club meets second Monday of each month. Annual exhibition in November. *President*, Richard M. Seibel; *Vice-President*, R. L. Walker; *Secretary-Treasurer*, Dr. Maclay Lyon. Member Associated Camera Clubs of America.

LITTLE ROCK CAMERA CLUB—Little Rock, Ark. Organized in spring, 1916. Limited membership. Advanced amateurs. Meets every two weeks. *President*, Dr. R. A. Tate, 5th and Main Streets; *Secretary*, Roderick Gallie, 411 W. 13th Street.

MISSOURI CAMERA CLUB—St. Louis, Mo. Club Rooms, 706 Merchants-Laclede Building, 408 Olive Street. Organized November, 1903. Meetings, second and fourth Tuesday. *President*, E. H. Wayman; *Vice-President*, Harvey W. Beggs; *Treasurer*, C. T. Sullivan; *Secretary*, F. K. Adams, 412 N. 6th Street, St. Louis.

MONTREAL AMATEUR ATHLETIC ASSOCIATION CAMERA CLUB—Montreal, Canada. Headquarters, M. A. A. Building, 250 Peel Street. Organized May 1, 1906. *President*, Gordon K. Miller; *Vice-President*, P. F. Calcutt; *Treasurer*, R. E. Melville.

NEWARK CAMERA CLUB, INC.—878-880 Broad Street, Newark, N. J. Organized 1888. Incorporated 1910. Meetings, second and fourth Mondays in each month. Motto, "SOMETHING OF INTEREST EVERY MONDAY NIGHT." *President*, Julius F. Graether; *Vice-President*, Arthur M. Platt; *Secretary*, Louis F. Bucher; *Treasurer*, Henry C. Brewster. Membership now 150 active. Member and organizer of Associated Camera Clubs of America.

NEW BRITAIN CAMERA CLUB—Organized 1892. *President*, James G. Henderson; *Vice-President*, W. B. Rossberg; *Secretary and Treasurer*, Paul A. Stahl, 260 Corbin Avenue, New Britain, Conn. Meets second and fourth Tuesdays, 173 Main Street. Member Associated Camera Clubs of America.

NEW HAVEN CAMERA CLUB—739 Chapel Street. Organized 1911. Membership, 35. *President*, John R. Shelden; *Vice-President*, Thomas Bowers; *Secretary and Treasurer*, J. George Blunden. Meetings held every Thursday. Business meetings, first Thursday in the month. Member Associated Camera Clubs of America.

OAK PARK CAMERA CLUB—Oak Park, Ill. Organized February, 1915. Membership, 25. *Director*, H. P. T. Matte; *President*, G. F. Chase; *Vice-President*, F. D. Manchester; *Secretary*, F. M. Ingals; *Treasurer*, Mrs. A. R. Hanson. Address communications to H. P. T. Matte, Lake Street and Lombard Avenue. Member Associated Camera Clubs of America.

- ORANGE CAMERA CLUB—East Orange, N. J. Headquarters, Main and Clinton Streets. Established March 21st, 1892. Incorporated May 19th, 1893. Membership, 100. Date of meetings, first and third Saturdays of each month, except July, August and September. *President*, Charles P. Titus; *Secretary*, Earl S. Rhine, Main and Clinton Streets, East Orange, N. J. Member Associated Camera Clubs of America.
- OREGON CAMERA CLUB—Portland, Oregon. Headquarters, Fifth Floor Elks' Building. Established 1895. Incorporated 1903. Membership, 100. Date of annual meeting, second Tuesday in January. *President*, Harry G. Smith; *Secretary*, Todd Hazen. Date of annual exhibit, early in Spring. Member Associated Camera Clubs of America.
- PHOTOGRAPHIC CLUB OF BALTIMORE CITY—Baltimore, Md. Headquarters, Maryland Academy of Sciences Building, 105 West Franklin Street. Established 1885. Incorporated 1890. Membership, active, 50. Meetings, first Tuesday in month. *President*, Lloyd D. Norris, Patterson Park, Baltimore; *Secretary*, N. Wright Crowder, 45 Hopkins Place, Baltimore. Member Associated Camera Clubs of America.
- PHOTOGRAPHIC SOCIETY OF PHILADELPHIA—Philadelphia, Pa. Headquarters, 1615-1617 Sansom Street. Established November, 1862. Incorporated April 24, 1885. Membership, 90. Date of meetings: Members, second Wednesday. *President*, Henry P. Bailey; *Secretary*, M. R. Witt, 1615 Sansom Street; *Treasurer*, Harold F. A. Starr. Date of members' annual exhibition, March.
- PICTORIAL PHOTOGRAPHERS OF AMERICA—New York City. Headquarters, National Arts Club, 119 East 19th Street. Meetings first Monday evening in each month from October to June. *President*, Clarence H. White; *Vice-President*, Dr. A. D. Chaffee; *Hon. Vice-Presidents*, Gertrude Kasebier, Prof. Chas. F. Chandler; *Treasurer*, Dr. Chas. H. Jaeger; *Recording Secretary*, Ed. R. Dickson; *Corresponding Secretary*, Margaret Watkins.
- PITTSBURGH ACADEMY OF SCIENCE AND ART (PHOTOGRAPHIC SECTION)—Pittsburgh, Pa. Headquarters, Carnegie Institute, Schenley Park. Organized January 23, 1900. Membership, 100. Meetings, second and fourth Tuesday in each month at Carnegie Institute. *President*, O. C. Reiter, 2424 Penn Avenue; *Vice-President*, M. C. Rypinski; *Secretary-Treasurer*, Chas. K. Archer, 1412 Carnegie Bldg., Pittsburgh, Pa.; *Lantern-Slide Director*, P. F. Souier, 483 Campbell Street, Wilkesburg, Pa. *Print Director*, S. A. Martin, 923 Chislett Street, Annual salon, Carnegie Art Gallery, March. Address all communications to Chas. K. Archer, Secretary, 1412 Carnegie Bldg., Pittsburgh, Pa.
- PITTSBURGH CAMERA CLUB—Pittsburgh, Pa. Established December, 1910. Membership, 15. *President*, Robert L. Sleeth, Jr.; *Treasurer*, William McK. Ewart, 2524 Center Avenue; *Secretary*, Charles W. Douth, Crafton, Pa.
- PITTSBURGH SALON OF PHOTOGRAPHIC ART—Pittsburgh, Pa. Under auspices of Photographic Section of the Academy of Science and Art. Membership consists of the leading pictorialists in the United States. *President*, O. C. Reiter, 2424 Penn Avenue, Pittsburgh, Pa.; *Secretary*, Charles K. Archer, 1412 Carnegie Bldg., Pittsburgh, Pa. Salon held Carnegie Institute, March. Last day of entry, February 10.
- PORTLAND CAMERA CLUB PHOTOGRAPHIC SECTION OF THE PORTLAND SOCIETY OF ART—Portland, Me. Headquarters, L. D. M. Sweat Memorial, Spring, corner High Street. Established 1899. Membership, 86. Date of meetings, every Monday evening. *President*, Francis O. Libby; *Vice-President*, Roger P. Jordan; *Secretary-Treasurer*, William T. Starr. Date of annual exhibition, in March. Member Associated Camera Clubs of America.
- POSTAL PHOTOGRAPHIC CLUB—Headquarters, Washington, D. C. Established December, 1888. Membership, 40. Date of meetings, no regular meeting. *President*, Charles E. Fairman; *Secretary*, Ernest L. Crandall, 1331 Newton Street, N. E., Brookland, Washington, D. C. Albums circulate among members monthly, except August and September.
- ST. LAWRENCE CAMERA CLUB—Ogdensburg, N. Y. Headquarters, 74 Caroline Street. Established 1900. Membership, 12. Date of meetings, at the call of the Secretary. *President*, Arthur L. Jameson; *Secretary*, John N. Brown, 74 Caroline Street.
- ST. LOUIS CAMERA CLUB—St. Louis, Mo. Organized February 12, 1914. Devoted to the interest and advancement of the art of photography. Meetings every second and fourth Thursday at 8 p. m., Central Public Library, Olive Street, between 13th and 14th Streets. *President*, Oscar C. Kuehn; *Vice-President*, Hector Updike; *Secretary*, S. F. Duckworth, 2838 Shenandoah Avenue, Shenandoah. Member Associated Camera Clubs of America.

- SOUTH CALIFORNIA CAMERA CLUB—522 Wilcox Building, Los Angeles. Membership, 40. *President*, Richard Mansfield; *Secretary*, Miss Close; *Librarian*, W. C. Sawyer. Meetings every Thursday evening. Lantern Slides third Thursday. Print competition (monthly subject), last Thursday evening. Ordinarily an annual exhibit or salon.
- TOLEDO CAMERA CLUB—Toledo, Ohio. Member of the American Federation. Headquarters, Museum of Art. Meet second Wednesday of each month. *President*, John F. Jones; *Vice-President*, R. E. Ferguson; *Secretary*, Harry A. Webb, 1017 Prouty Avenue; *Treasurer*, M. W. Chapin.
- TRINIDAD CAMERA CLUB—Trinidad, Colo. Established April 21, 1906. Meetings, second Wednesday of every month at O. E. Aultman's Studio. Monthly competitions. *President*, W. L. Crouch; *Vice-President*, Wilber Davis; *Secretary and Treasurer*, W. Dearden, 717 Colorado Avenue. Member Associated Camera Clubs of America.
- WASHINGTON Y. M. C. A. CAMERA CLUB—Washington, D. C. Headquarters, Central Y. M. C. A. Building. Membership, 32. *President*, William D. Cunningham; *Vice-President*, E. S. Towers; *Treasurer*, C. Maxford; *Secretary*, R. A. Pullis, Room 513, Y. M. C. A.
- WESLEY CAMERA CLUB—Headquarters, Bell Theatre Building. Organized April 6, 1912. Meeting the first Monday of each month. *President*, W. A. Drewelow; *Vice-President*, Halvor Flom; *Secretary and Treasurer*, Lawrence Burke (Wesley, Iowa).
- YONKERS CAMERA CLUB—Yonkers, N. Y. Headquarters, Hollywood Inn Building. *President*, W. R. Cronk; *Vice-President*, H. B. Spreckles; *Secretary*, Elijah F. Munn; *Librarian*, C. B. Carling; *Trustees*, Wm. Beck, Wm. S. Mitchell, Geo. Stengel.



THEODORE EITEL.

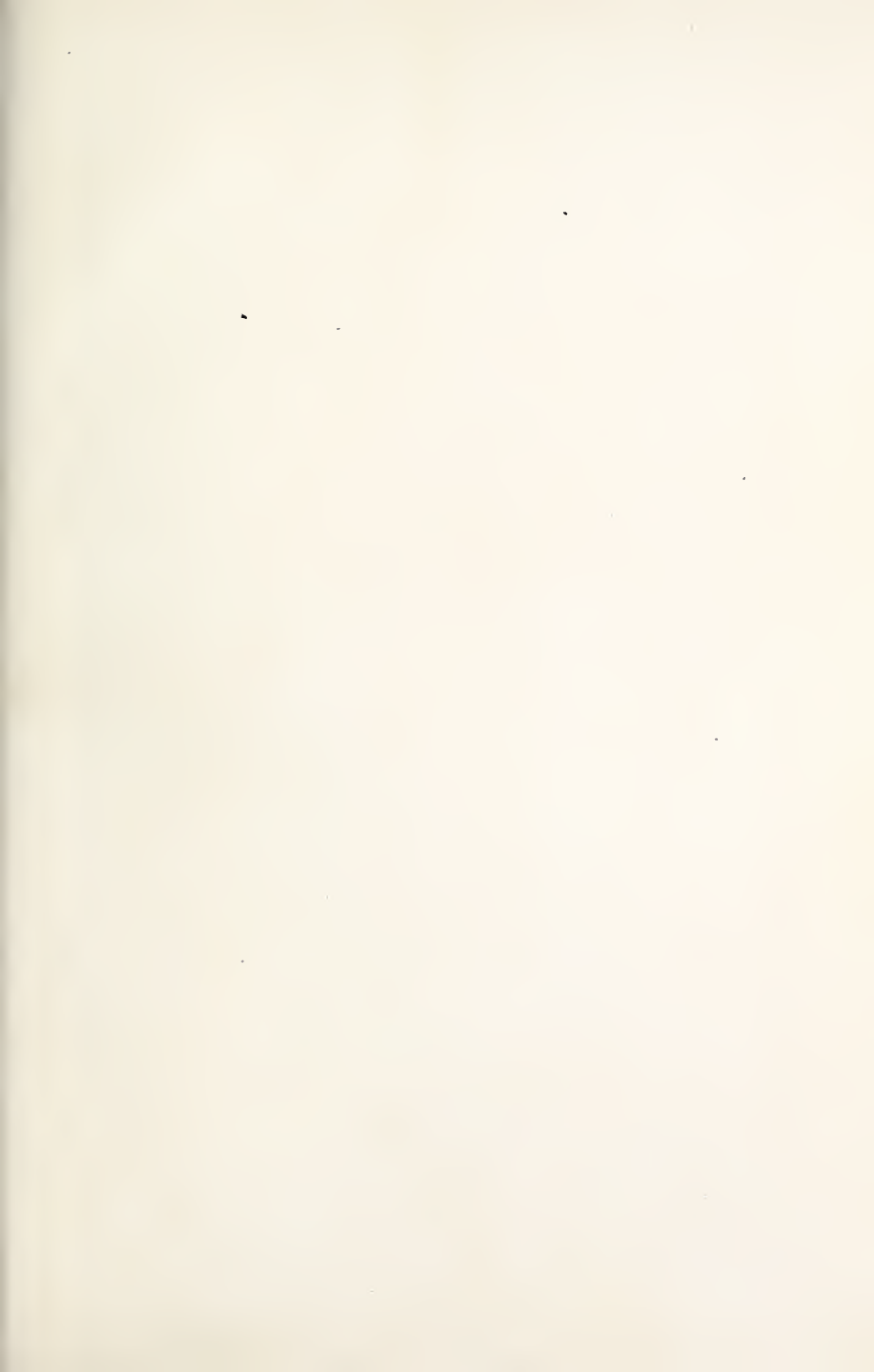



GETTY CENTER LIBRARY



3 3125 00896 4468

