

**Lehigh
University**



TWO-WAY FLEXURAL BEHAVIOR OF
STEEL-DECK-REINFORCED
CONCRETE SLABS

BY

CHARLES R. KUBIC

LT, CEC, USN

MAY 1978

Approved for Public Release;
Distribution unlimited.

**Fritz
Engineering
Laboratory**

REPORT DOCUMENTATION PAGE

READ INSTRUCTIONS
BEFORE COMPLETING FORM

1. REPORT NUMBER		2. GOVT ACCESSION NO.	3. RECIPIENT'S CATALOG NUMBER
4. TITLE (and Subtitle) Two-way Flexural Behavior of Steel-Deck Reinforced Concrete Slabs		5. TYPE OF REPORT & PERIOD COVERED Thesis	
		6. PERFORMING ORG. REPORT NUMBER	
7. AUTHOR(s) Charles R. KUBIC		8. CONTRACT OR GRANT NUMBER(s)	
9. PERFORMING ORGANIZATION NAME AND ADDRESS Lehigh University Bethlehem, PA		10. PROGRAM ELEMENT, PROJECT, TASK AREA & WORK UNIT NUMBERS	
11. CONTROLLING OFFICE NAME AND ADDRESS NAVPGSCOL CODE 031		12. REPORT DATE MAY 78	
		13. NUMBER OF PAGES 62	
14. MONITORING AGENCY NAME & ADDRESS (if different from Controlling Office)		15. SECURITY CLASS. (of this report) UNCLASS	
		15a. DECLASSIFICATION/DOWNGRADING SCHEDULE	
16. DISTRIBUTION STATEMENT (of this Report) A. Approved for public release; distribution unlimited.			
17. DISTRIBUTION STATEMENT (of the abstract entered in Block 20, if different from Report)			
18. SUPPLEMENTARY NOTES			
19. KEY WORDS (Continue on reverse side if necessary and identify by block number) Flexural Behavior; Steel Deck Reinforced; Concrete Slabs			
20. ABSTRACT (Continue on reverse side if necessary and identify by block number)			

Approved for Public Release;
Distribution unlimited

TWO-WAY FLEXURAL BEHAVIOR
OF
STEEL-DECK-REINFORCED CONCRETE SLABS

By

Charles R. Kubic
LT, CEC, USN

This research was carried out in partial fulfillment of the requirements for the degree of Master of Science in Civil Engineering.

Department of Civil Engineering

Fritz Engineering Laboratory
Lehigh University
Bethlehem, Pennsylvania

May 1978

ACKNOWLEDGEMENTS

This research was conducted at Fritz Engineering Laboratory, Lehigh University, Bethlehem, Pa. and was carried out in conjunction with postgraduate study in Structural Engineering sponsored by the Chief of Naval Operations. Dr. Lynn S. Beedle is Director of Fritz Engineering Laboratory and Dr. David A. VanHorn is Chairman of the Department of Civil Engineering.

Appreciation is expressed to Ms. S. Matlock who carefully typed this report, to Mr. J. M. Gera who skillfully prepared the illustrations, and to Mr. T. Wenk who initiated preliminary studies on this topic in May 1977. Finally, the author is indebted to Dr. J. Hartley Daniels, who served as his advisor and who consistently provided learned guidance throughout the preparation of this report.

TABLE OF CONTENTS

	<u>Page</u>
ABSTRACT	1
1. INTRODUCTION	3
1.1 Current Practice	4
1.2 Current Research	6
1.3 Purpose and Scope	8
1.4 Assumptions	9
2. FINITE ELEMENT MODEL DEVELOPMENT	10
2.1 Orthotropic Plate Theory	11
2.2 Alternative Models	15
2.3 Model Parameters	16
3. ORTHOTROPIC PLATE ANALYSIS	19
3.1 Governing Equations	19
3.2 Summary of Results	21
4. MODEL VALIDATION	22
4.1 Convergence Study	22
4.2 Comparison with Alternate Model	23
4.3 Comparison with Theoretical Results	24
4.4 Comparison with Test Results	25
5. PARAMETRIC STUDY	27
5.1 Purpose and Scope	27
5.2 Results	28
6. CONCLUSIONS AND RECOMMENDATIONS	31
7. NOMENCLATURE	35
8. TABLES	38
9. FIGURES	42
10. APPENDICES	55
11. REFERENCES	62

LIST OF TABLES

<u>TABLE</u>		<u>PAGE</u>
1	Section and Material Properties	39
2	Orthotropic Plate Constants	40
3	Comparison of Theoretical and Finite Element Model Results	41

LIST OF FIGURES

<u>FIGURE</u>		<u>PAGE</u>
1	Alternate Conventional Floor Systems	43
2	Typical Cross Section	44
3	Model Development	45
4	Structurally Orthotropic Finite Element Model	46
5	Typical Finite Element Model Discretization	47
6	Convergence Study-Deflections	48
7	Convergence Study-Moments	49
8	Comparison of Model and Test Results (One-Way Bending)	50
9	Comparison of Model and Test Results (Two-Way Bending)	51
10	Aspect Ratio Parametric Study	52
11	Deflection Coefficient vs. Aspect Ratio	53
12	Moment Coefficients vs. Aspect Ratio	54

LIST OF APPENDICES

<u>APPENDIX</u>		<u>PAGE</u>
A	Computation of Model Parameters	56
B	Computation of Theoretical Deflections and Moments	58
C	Optimum Aspect Ratio	60

ABSTRACT

The two-way flexural behavior of steel-deck-reinforced concrete slabs is examined and the feasibility of considering two-way action in the design of such slabs is discussed. An elastically orthotropic finite element model with uniform thickness is developed which simulates the behavior of a structurally orthotropic steel-deck-reinforced concrete slab. The model development is based upon appropriate modifications to the elasticity constants and to the thickness of the plate bending element included in the SAP IV⁽¹⁾ finite element program. The linear, elastic, uncracked behavior of a typical steel-deck-reinforced concrete slab is examined utilizing the elastically orthotropic model; and, the resulting deflections and moments are observed to conform with theoretical results and with a more sophisticated structurally orthotropic model. The elastically orthotropic finite element model is also correlated with previously tested steel-deck-reinforced concrete slabs and the results predicted by a finite element analysis are found to conform with the actual test results in the uncracked region.

The results of a limited parametric study, which considers the relative effects of aspect ratio, rib span direction, and edge support conditions on two-way flexural behavior, are presented. Deflections and bending moments for two-way flexural action are compared with similar values for one-way bending and an expression is proposed for computing an optimum aspect ratio for a given orthotropic steel-deck-reinforced concrete slab.

Although the analysis in this report is based upon several simplifying assumptions, the two-way design of steel-deck-reinforced concrete slabs is nevertheless found to be a feasible and potentially advantageous concept.

1. INTRODUCTION

Cold-formed steel decking, as shown in Fig. 1(a), is extensively utilized in the construction of floor systems for steel framed buildings and often serves the dual function of providing forming for concrete during slab construction and positive reinforcement for the floor slab under service conditions. In addition to simplifying forming and reducing reinforcing steel, such a floor system also provides a safe working platform during construction; can easily accommodate pre-engineered raceways for electrical, communications, and air distribution systems; and, upon completion, presents a finished underside with no visible cracks. However, steel-deck-reinforced concrete slab systems are generally heavier and thicker than alternate floor systems, such as flat plate concrete slabs (Fig. 1(b)), and despite numerous advantages, their general application is often limited by both technical and economic considerations. Such limitations are directly linked to the method of one-way flexural analysis utilized in the conventional design of steel-deck-reinforced concrete floor systems. Reinforced concrete floor slabs, on the other hand, are routinely analyzed as two-way flexural systems to achieve overall economy of design. The two-way flexural behavior of steel-deck-reinforced concrete slabs will be examined in this report and the feasibility of designing such slabs to take advantage of two-way flexural action will be discussed.

1.1 Current Practice

Although steel deck floor systems generally result in a thicker "floor sandwich" than flat plate concrete floor systems, they are usually much easier to install, and, in particular, they provide additional flexibility for the installation of under-floor utility systems. Consequently, steel-deck-reinforced concrete floor systems can often be economically utilized in commercial facilities, office buildings, or hospitals. However, they are less economical for residential facilities such as apartment buildings, hotels, or dormitories which have fixed interior partitions and do not depend upon the floor system for installation of utility lines. The overall cost of high-rise buildings is particularly sensitive to the overall thickness of the "floor sandwich" and facilities which do not require mechanized or electrified floor systems can often be more economically constructed utilizing precast concrete floor panels or flat plate concrete slabs.

Steel decking is often utilized strictly as stay-in-place forming material and alternate reinforcing is provided for the concrete slab. Steel-deck reinforced concrete floor slabs, however, are composite structural systems which achieve satisfactory composite action by developing positive interlocking between the steel deck and the concrete. Steel decks are currently manufactured which utilize various patterns of embossments to mechanically transfer horizontal shear and to prevent vertical separation between the deck and the concrete. The load carrying capacities of such composite

sections are normally established through proprietary performance tests conducted by the various manufacturers, and design is generally based upon one-way bending of simple span slabs. However, a flexural mode of failure is rarely achieved for typical sections spanning moderate (6-12 ft) lengths, and design is often governed by other criteria such as shear-bond failure, allowable deck stresses during construction, or acceptable deflections during construction or service loading. Additionally, the thickness of steel deck floor systems may also be governed by required fire resistance ratings.

The various steel-deck manufacturers generally recommend maximum one-way spans in the range of 15 feet for steel-deck-reinforced concrete slabs. However, spans of 6-10 feet are more commonly utilized so as to obviate the need for expensive temporary shoring and to minimize the depth of supporting members. As mentioned earlier, a steel deck floor system, with its associated beam/joist framing system will generally result in a relatively thicker "floor sandwich" than a concrete flat plate or pre-cast floor system. However, in commercial facilities requiring extensive underfloor utility systems and mechanized or electrified floors, cellular steel deck, in particular, can provide an alternative, economically feasible floor system when constructed compositely with the concrete slab.

1.2 Current Research

Extensive research on steel-deck-reinforced concrete slabs subjected to one-way bending has been conducted at Iowa State University by Ekberg, Schuster, and Porter.^(2,3,4,5) Test results have indicated that the shear-bond failure mode is predominant over the flexural failure mode, particularly in shorter spans; and, it has therefore been recommended that such a failure mode should be a primary design consideration. Shear-bond failure was classified as a brittle type of failure characterized by the formation of an approximately diagonal crack (resulting from excessive principal tension stresses) which resulted in end slip and a loss of bond between the steel deck and the concrete. It was observed that shear-bond capacity increased with an increase in depth, a decrease in shear span, or an increase in the compressive strength of concrete. An ultimate strength design procedure, which incorporates a specified testing program to establish shear-bond capacity, was proposed for steel-deck reinforced concrete slabs subjected to one-way bending.

Limited research has also been conducted by Porter and Ekberg⁽⁶⁾ on the behavior of steel-deck-reinforced concrete slabs subjected to two-way bending. Five simply supported slabs (12 ft x 16 ft) with varying section properties and with ribs spanning 12 feet were subjected to four concentrated loads near the center span region, and failure mode, cracking pattern and end reactions were observed. All five slabs failed ultimately by a shear-bond type of failure, characterized by horizontal end slippage accompanied by the development of

diagonal cracks. End slippage was similar to that experienced in one-way slab tests, however no end slip was observed along the edges transverse to the span of the steel deck ribs.

Although none of the five slabs failed by extensive yielding of the steel deck, some limited yielding of the steel deck did occur in the central regions near the concentrated load points. Measured end reactions indicated that about 78% of the total applied load during the initial load applications was transmitted in the strong direction. However, near ultimate load, one-way bending was predominate and 97% of the total force was carried in the strong direction. Maximum edge reactions in the weak direction usually occurred when the live load was 50% of the ultimate load or at approximately the working load level.

Porter⁽⁶⁾ recommended that analysis of steel-deck-reinforced concrete slabs subjected to two-way bending consider only the section above the deck corrugations as effective for transverse flexural action. Moreover, he suggested that only supplementary steel in the transverse direction be considered for computing flexural capacity and that any contribution from the steel deck should be neglected. Porter observed that a slab which had 6x12 D0xD4 WWF placed directly on top of the steel decking had a higher ultimate load than slabs without such reinforcement. It is quite possible that supplementary transverse reinforcement increases both shear bond and transverse flexural capacity and thus increases the overall ultimate capacity of a two-way steel-deck-reinforced concrete slab. Porter's results are discussed further in Art. 4.4.

1.3 Purpose and Scope

The desired failure mode of any reinforced concrete structural system is a flexural failure of an under-reinforced cross section. Steel-deck-reinforced concrete slab sections commonly utilized in building construction will predominantly experience shear bond failure or excessive deflections prior to reaching their ultimate flexural capacity. Consequently, such sections actually fail prematurely, thus lowering allowable loadings or reducing allowable span lengths. If all factors which precipitate failure prior to the achievement of ultimate flexural capacity could be controlled and a flexural failure realized, steel decking could be more efficiently utilized as reinforcement for concrete floor slabs. Moreover, the relative economic benefits of steel-deck-reinforced concrete floor slabs could be significantly improved if such slabs were designed as two-way flexural systems.

An elastically orthotropic finite element model with constant thickness will be developed to facilitate the analysis of structurally orthotropic steel-deck-reinforced concrete slabs. The elastically orthotropic model will be compared with theoretical results, with a more refined structurally orthotropic finite element model, and with one-way and two-way test results as compiled by Ekberg, Schuster, and Porter.^(2,6) Once validated, the finite element model will be utilized to conduct a limited parametric study in which the relative effects of aspect ratio, rib span direction, and edge support condition will be examined. The general feasibility of designing steel-deck-reinforced concrete slabs as two-way flexural systems will be discussed;

however, it is recognized that much more intensive analytical studies as well as extensive laboratory tests are necessary to confirm the findings of this preliminary research. In effect, this report serves as a "ground level" feasibility study on the two-way flexural behavior of steel-deck-reinforced concrete slabs.

1.4 Assumptions

The limited scope of this investigation is unavoidably constrained by several basic assumptions. Such assumptions will necessitate careful interpretation of the findings of this study, but will not invalidate their basic significance. In general, all analyses have been performed on the basis of linear elastic behavior of an uncracked cross section. More specifically it has been assumed that:

- a. Additional transverse and longitudinal reinforcement will be added to the cross section as required to maintain the same relative uncracked stiffnesses subsequent to cracking as well as to satisfactorily resist two-way bending moments.
- b. Shear bond failure can be prevented prior to flexural failure by modifying the steel deck profile (embossments), by adding specialized shear connectors, by applying special adhesive coatings, or by some other acceptable technique.
- c. Excessive deflections and/or construction loadings can be economically controlled by improved shoring techniques, by two-way flexural action of the steel deck alone, by pre-cast construction or by other suitable techniques.

2. FINITE ELEMENT MODEL DEVELOPMENT

The SAP IV⁽¹⁾ finite element computer program provides several alternative methods for modeling a steel-deck-reinforced concrete slab subjected to distributed or concentrated loads perpendicular to the plane in which it lies. The plate bending element provides the most convenient and efficient method for analyzing isotropic plate bending problems and can readily be adapted to elastically orthotropic problems by properly populating the plane stress material elasticity matrix given as follows:

$$\begin{Bmatrix} \sigma_{xx} \\ \sigma_{yy} \\ \tau_{xs} \end{Bmatrix} = \begin{bmatrix} C_{xx} & C_{xy} & C_{xs} \\ C_{xy} & C_{yy} & C_{ys} \\ C_{xs} & C_{ys} & G_{xy} \end{bmatrix} \begin{Bmatrix} \epsilon_{xx} \\ \epsilon_{yy} \\ \gamma_{xy} \end{Bmatrix} \quad 2.1$$

where,

$$\begin{aligned} C_{xx} &= C_{yy} = \frac{E}{1-\nu^2} \\ C_{xy} &= \frac{\nu E}{1-\nu^2} \\ C_{xs} &= C_{ys} = 0 \\ G_{xy} &= \frac{E}{2(1+\nu)} \end{aligned} \quad 2.2$$

for the case of isotropic plate bending.

In isotropic or elastically orthotropic plate bending problems, the finite element is given a specified uniform thickness and appropriate rigidity factors are computed utilizing the specified elasticity constants. However, a structurally orthotropic steel-deck reinforced concrete slab, with typical cross section as shown in Fig. 1(a)⁽⁷⁾,

can not be modeled as conveniently using plate bending elements. On the other hand, however, alternative models utilizing more sophisticated elements become more complex as well as exponentially more expensive. Consequently, elasticity parameters were developed which permitted the modeling of a structurally orthotropic plate as an elastically orthotropic plate with an equivalent uniform thickness, and analytical results were compared with results generated by a more sophisticated finite element model as well as with theoretical and test results.

2.1 Orthotropic Plate Theory

For engineering applications, an orthotropic plate is defined⁽⁸⁾ as a plate having different bending stiffnesses ($D = EI$) in two orthogonal directions X and Y in the plane of the plate. The variation in bending stiffness may result either from different moduli of elasticity E_x and E_y in two orthogonal directions, as in the case of naturally or elastically orthotropic plates, or from different moments of inertia I_x and I_y per unit width, as in the case of technically or structurally orthotropic plates.

Huber's general differential equation for the bending of an orthotropic plate is expressed as follows:⁽⁸⁾

$$D_x \frac{\partial^4 w}{\partial x^4} + 2H \frac{\partial^4 w}{\partial x^2 \partial y^2} + D_y \frac{\partial^4 w}{\partial y^4} = q(x,y) \quad 2.3$$

where
$$2H = D_x \nu_y + D_y \nu_x + 4 D_{xy} \quad 2.4$$

The quantities D_x and D_y are termed the flexural rigidities of the plate while D_{xy} represents the torsional rigidity of the plate. The

value of $2H$ from Eq. 2.4 is termed the effective torsional rigidity of the orthotropic plate.

In general terms, Eq. 2.3 relates the plate's deflection surface $w(x,y)$ to a given load distribution $q(x,y)$. To apply the solution of Eq. 2.3 to engineering problems, it is necessary to evaluate proper values for the constants D_x , D_y , D_{xy} , ν_x , and ν_y . For an elastically orthotropic slab of uniform thickness (h), the constants are defined as follows:

$$\begin{aligned}
 D_x &= \frac{E_x h^3}{12(1-\nu_x \nu_y)} \\
 D_y &= \frac{E_y h^3}{12(1-\nu_x \nu_y)} \\
 D_{xy} &= \frac{G_{xy} h^3}{12}
 \end{aligned}
 \tag{2.5}$$

$$E_x \nu_y = E_y \nu_x \text{ (from Betti's reciprocal theorem)}$$

The values of the moduli of elasticity E_x and E_y and the corresponding Poisson's constants ν_x and ν_y are usually known for a given elastically orthotropic material. However, the value of the shear modulus G_{xy} , which is encountered in the expression for the torsional rigidity D_{xy} , and which consequently also influences the effective torsional rigidity H , is usually unknown.

An approximate value of the effective torsional rigidity can be theoretically expressed by the equation, ⁽⁸⁾

$$H = \sqrt{D_x D_y} \tag{2.6}$$

if an analogy is drawn with the expression for the twisting moment of an isotropic plate utilizing $D = \sqrt{D_x D_y}$ and $\nu = \sqrt{\nu_x \nu_y}$ as representative "middle values" of the bending rigidity and Poisson's constant. This approximation is valid only if the orthotropic plate satisfies the following conditions:

- a. uniform thickness
- b. purely elastic deformations
- c. relatively small deformations.

Because such assumptions are not actually satisfied in reality, particularly for a structurally orthotropic plate, it has been suggested⁽⁸⁾ that the value of H should be reduced by a coefficient of torsional rigidity γ , so that

$$H = \gamma \sqrt{D_x D_y} \quad 2.7$$

where $\gamma < 1$ and normally varies between 0.3 and 0.5.

A proper theoretical expression for G_{xy} is particularly important when modeling a structurally orthotropic plate as an equivalent elastically orthotropic plate for a finite element analysis. Szilard⁽⁹⁾ suggests that G_{xy} for an orthotropic material can be approximately expressed as follows:

$$G_{xy} \approx \frac{\sqrt{E_x E_y}}{2(1 + \sqrt{\nu_x \nu_y})} \quad 2.8$$

or if $E_x \approx E_y \approx E$

$$G_{xy} \approx \frac{E}{2(1 + \sqrt{\nu_x \nu_y})} \quad 2.9$$

In discussing structurally orthotropic steel bridge deck systems, Troitsky⁽⁸⁾ suggests that G_{xy} be expressed as follows:

$$G_{xy} = \frac{E_x E_y}{E_x + (1+2\nu_x)E_y} \quad 2.10$$

but recommends that a direct test be conducted to obtain a more reliable value for G_{xy} .

The expressions for bending rigidity given in Eq. 2.5 must also be modified for structurally orthotropic plates. For a slab reinforced on one side by a set of equidistant ribs, Timoshenko⁽¹⁰⁾ suggests that bending rigidities can be approximated by the following expressions:

$$D_x = \frac{E a_1 h^3}{12(a_1 - t + \alpha^3 t)} \quad 2.11$$

$$D_y = \frac{EI}{a_1} \quad 2.12$$

if the effect of transverse contraction is neglected (i.e., $\nu_x = \nu_y = \nu = 0$). D_x represents the effective weak direction rigidity transverse to the ribs, while D_y represents the strong direction rigidity parallel to the ribs. I is the moment of inertia of a T-section of width a_1 , and $\alpha = \frac{h}{H}$. The constants a_1 , h , H , and t are defined in Fig. 2 for a typical steel-deck-reinforced concrete slab cross section.

It is obvious from the foregoing discussion that orthotropic plate bending theory provides, at best, only an approximate solution for structurally orthotropic slabs with unsymmetrical ribs. Nevertheless, orthotropic plate bending theory will be applied in the development of elasticity parameters for a finite element model in an attempt to

provide a comparably accurate finite element solution for a structurally orthotropic steel-deck-reinforced concrete slab.

2.2 Alternative Models

The finite element model was developed by considering the typical cross section shown in Fig. 2 spanning a 16 ft x 16 ft panel with four simply supported edges. A representative section of the actual structurally orthotropic slab is illustrated in Fig. 3(a). The models shown in Figs. 3(b) and (c) would provide lower and upper bound solutions for two-way flexure of the slab. The uniform thickness of such a model would facilitate finite element discretization, however, the effects of the steel plate must necessarily be considered by utilizing an equivalent uniform model thickness, based upon the cross section's transformed moment of inertia. The actual results obtained from such an analysis would be relatively insignificant despite the fact that they would bound the correct solution.

Figure 4 illustrates a rather sophisticated finite element discretization utilizing 8-node bricks to model the concrete, and plate bending elements to model the steel deck. While such a model should provide excellent results, its complexity and expense degrade its usefulness for general application. A comparison between this model and the elastically orthotropic model is presented in Art. 4.2.

Modeling the structurally orthotropic slab as an isotropic plate supported by beams representing the ribs would provide still

another alternative. However, correctly modeling torsional rigidity with such a discretization could prove quite difficult. In the final analysis, the most efficient and effective model is one in which plate bending elements alone are utilized with appropriately modified elasticity constants and a specified equivalent uniform thickness. Such a model simulates the behavior of a structurally orthotropic slab by that of an equivalent elastically orthotropic slab of uniform thickness.

2.3 Model Parameters

The modeling of a structurally orthotropic slab by an elastically orthotropic slab of uniform thickness was accomplished as follows:

- a. The uncracked moment of inertia (I_y) per unit width was computed in the strong direction utilizing the transformed area concept to incorporate the effect of the steel deck
- b. The uncracked moment of inertia (I_x) per unit width was computed in the weak direction neglecting any contribution from the steel deck or from the ribs
- c. An effective moment of inertia (I_{xe}) per unit width was defined for the weak direction; I_{xe} considers the effect of the ribs by utilizing Timoshenko's⁽¹⁰⁾ expression for the weak direction bending rigidity (Eq. 2.11):

$$I_{xe} = \frac{a_1 h^3}{12(a_1 - t - \alpha^3 t)} \quad 2.13$$

- d. The modulus of elasticity of concrete, E_c , was modified by the following expressions to simulate orthotropic elasticity:

$$E_x = \frac{I_{xe}}{I_x} (E_c) \quad 2.14$$

$$E_y = \frac{I_y}{I_{xe}} (E_c) \quad 2.15$$

e. Poisson's ratio for concrete (ν_c) was modified as follows:

$$\nu_x = \frac{I_{xe}}{I_y} (\nu_c) \quad 2.16$$

$$\nu_y = \frac{I_x}{I_{xe}} (\nu_c) \quad 2.17$$

so as to maintain the equality $\nu_x E_y = \nu_y E_x = \nu_c E_c$

f. Orthotropic elasticity constants were computed as follows

utilizing E_x , E_y , ν_x and ν_y :

$$C_{xx} = \frac{E_x}{1 - \nu_x \nu_y} \quad 2.18$$

$$C_{yy} = \frac{E_y}{1 - \nu_x \nu_y} \quad 2.19$$

$$C_{xy} = \frac{\sqrt{\nu_x \nu_y E_x E_y}}{1 - \nu_x \nu_y} \quad 2.20$$

$$G_{xy} = \frac{E_x E_y}{E_x + (1 + 2 \nu_x) E_y} \quad 2.21$$

g. An equivalent uniform slab thickness was computed as follows:

$$t_e = \sqrt[3]{12 I_{xe}} \quad 2.21$$

In general terms, this modeling technique simulates structural orthotropy by proportionately increasing the modulus of elasticity of concrete to reflect effective moments of inertia in the strong and weak direction, while incorporating an equivalent uniform thickness. This technique does, however, possess one inconsistency in that the simulated bending rigidity in the weak direction is relatively higher than would be theoretically deduced. This results from the fact that both the moment of inertia and the modulus of elasticity in the weak direction are increased resulting in a relatively higher increase in rigidity in the model's weak direction as compared to its strong direction. The significance of this inconsistency is discussed later.

Troitsky's value for G_{xy} (Eq. 2.10) was selected because of its general applicability to structurally orthotropic slabs and because of the good correlation which it produced with both theoretical solutions and test results.

Uncracked section properties and material properties for the typical section utilized in the model's development are listed in Table 1. The computation of model parameters is included in Appendix A, and the final elastically orthotropic slab model is illustrated in Fig. 3(d).

3. ORTHOTROPIC PLATE ANALYSIS

For the case of a uniformly loaded, simply supported rectangular orthotropic plate, Eq. 2.3 can be solved utilizing the Navier method.⁽¹⁰⁾ This solution expresses the plate's deflection surface in terms of a double trigonometric series:

$$w = \frac{16 q_0}{\pi^2} \sum_{m=1,3,5\dots}^{\infty} \sum_{n=1,3,5\dots}^{\infty} \frac{\sin \frac{m\pi x}{a} \sin \frac{n\pi y}{b}}{mn \left(\frac{m^4}{a^4} D_x + \frac{2m^2 n^2}{a^2 b^2} H + \frac{n^4}{b^4} D_y \right)} \quad 3.1$$

Tabularized solutions are available for Eq. 3.1 for the particular case of $H = \sqrt{D_x D_y}$. Although such a case is normally representative of elastically orthotropic plates, such as two-way reinforced concrete slabs, it will nevertheless be applied to a structurally orthotropic steel-deck-reinforced concrete slab utilizing the elasticity constants computed for the finite element model parameters.

3.1 Governing Equations

For the case in which $H = \sqrt{D_x D_y}$, the deflection and the bending moments at the center of an orthotropic plate can be expressed by the following equations:

$$w = \frac{\alpha q_0 b^4}{D_y} \quad 3.2$$

$$M_{xx} = \left(\beta_2 + \beta_1 \frac{C_{xy}}{C_{yy}} \sqrt{\frac{D_y}{D_x}} \right) q_o b^2 \quad 3.3$$

$$M_{yy} = \left(\beta_1 + \beta_2 \frac{C_{xy}}{C_{xx}} \sqrt{\frac{D_x}{D_y}} \right) \frac{q_o a^2}{\epsilon} \quad 3.4$$

where α , β_1 , and β_2 are numerical coefficients given in Table 2 and

$$\epsilon = \frac{a}{b} \sqrt[4]{\frac{D_y}{D_x}} \quad 3.5$$

If the effect of transverse contraction is neglected C_{xy} becomes equal to zero and Eqs. 2.11 and 2.12 can be directly applied to calculate D_x and D_y . However, transverse contraction is considered by the finite element analysis and consequently a more appropriate comparison should be achieved by modifying D_x and D_y as follows:

$$D_x = \frac{E a_1 h^3}{(1-\nu_y^2)(12)(a_1 - t + \alpha^3 t)} \quad 3.6$$

$$D_y = \frac{E I}{(1-\nu_x^2)(a_1)} \quad 3.7$$

A sample computation of theoretical deflections and moments is included in Appendix B for a simply supported, 16 ft square, orthotropic plate subjected to a uniform load of .001 ksi (144 psf). The typical cross section shown in Fig. 2 and the total load $q_o = .001$ ksi, which is in the normal working load range, were used for all computations.

3.2 Summary of Results

The results of theoretical deflection and moment computations for various aspect ratios are listed in Table 3. The comparison of these results with values predicted by the finite element model is presented later; however, it is important to note that the theoretical results are in themselves approximate in nature. Although they are assumed to be the "exact" values for model validation, the significance of minor discrepancies must be evaluated with consideration given to the possibility of error in the theoretical values.

4. MODEL VALIDATION

Several approaches were taken to confirm the validity of the finite element model as well as to ascertain the degree of discretization necessary to achieve results with acceptable accuracy. Model validation included a convergence study, comparison with an alternate, more sophisticated model, comparison with theoretical results, and comparison with test results. In all instances the model was observed to have an acceptable degree of accuracy.

4.1 Convergence Study

Figure 5 illustrates the typical slab discretization utilized during development of the model parameters. Quarter symmetry was utilized and the degrees of freedom at the boundaries were set equivalent to those of simply supported edges. The discretization in Fig. 5 includes 81 nodal points and 64-12 inch square, elastically orthotropic plate bending elements of uniform thickness. In addition to the discretization shown in Fig. 5, a coarser mesh (16 elements - 24 inches square) and a finer mesh (256 elements - 6 inches square) were utilized in the convergence study.

Figure 6 shows excellent convergence towards the "exact" center deflection as computed in Appendix B. As evidenced in Fig. 6, the finite element model is "stiffer" than the theoretical slab and the computed deflections are actually lower bound values. This is as would be expected since SAP IV type VI plate bending elements are conformable elements.⁽¹⁾

Similarly, Fig. 7 shows very good convergence towards the "exact" strong axis moment. Convergence is also obtained in the weak direction; however, it is quite apparent that the "exact" value for the weak axis moment is strongly influenced by the degree of transverse contraction assumed in the theoretical analysis.

For the purposes of this report, it was determined that the accuracy of the mesh illustrated in Fig. 5 was adequate, and that the utilization of the finer mesh (at over 3 times the cost) was not necessary. All subsequent studies are conducted utilizing 12 inch square elements.

4.2 Comparison with Alternate Model

A comparison was made between a 12 inch square elastically orthotropic plate bending element and the structurally orthotropic finite element model shown in Fig. 4 primarily to determine the accuracy of the assumed expression for G_{xy} (Eq. 2.10).

The structurally orthotropic model was composed of 8-node bricks, which represented the concrete, and isotropic plate bending elements, which represented the steel deck. The elastically orthotropic model was defined by the elasticity parameters and equivalent thickness computed in Appendix A. A 12-inch square module of each type was simply supported at three of its corners while a unit load was applied at the fourth corner. The elastically orthotropic element had a corner deflection of 0.0024166 inches while the structurally orthotropic model had a corresponding deflection of 0.0024145 inches. The

resulting error is less than 0.1% and is entirely acceptable. This comparison supports the validity of the assumed expression for G_{xy} as well as the overall adequacy of the elastically orthotropic model.

The cost associated with the more sophisticated 8-node brick model was approximately ten times that of the elastically orthotropic plate bending model. This observation further supports the selection of the elastically orthotropic plate bending model.

4.3 Comparison with Theoretical Results

The theoretical analysis of simply supported, uniformly loaded, rectangular orthotropic plates is discussed in Art. 3 and sample computations are included in Appendix B. Theoretical deflections and moments were similarly calculated for various aspect ratios and are summarized in Table 3 along with corresponding values computed by a SAP IV finite element analysis utilizing the elastically orthotropic model previously discussed. (The parametric study, which considers the relative effects of aspect ratio, is discussed in detail in Art. 5). The tabulated values show excellent agreement for deflections and strong axis moments; however the correlation is less than satisfactory for weak axis moments. Moreover, it is apparent that the correlation becomes increasingly worse as the weak direction span increases. However, it is also observed that at some aspect ratio (between 1.33 and 1.00) an exact correlation is achieved.

If an alternate theoretical analysis is made which neglects the effect of transverse contractions as related to weak direction moments

(i.e., $\nu = 0$), the correlation between the finite element and the theoretical analysis greatly improves, particularly at larger aspect ratios. This observation is noted in Table 3 and seems to indicate that the relative effect of transverse contraction varies with aspect ratio and has a much more significant effect on the weak direction moments than on either the center deflections or the strong direction bending moments. The consistency of all other results indicates that the weak direction moments computed by the finite element analysis are "more correct" than the approximate theoretical values. This observation is based upon the assumption that the relative significance of transverse contraction will be appropriately considered by the numerical finite element solution for a particular aspect ratio. The theoretical solution, on the other hand, is directly tied to an assumed degree of transverse contraction, and does not necessarily apply "exactly" to a structurally orthotropic plate.

4.4 Comparison with Test Results

Although this investigation was primarily analytical in nature an effort was made to correlate results predicted by the finite element model with available test results for steel-deck-reinforced concrete slabs.

Figure 8 illustrates actual results obtained by Schuster and Ekberg⁽²⁾ during one of their numerous tests on steel-deck-reinforced concrete slabs subjected to one-way bending. The test specimen was modeled utilizing the parameters previously discussed and the analytical results were also plotted in Fig. 8. An additional analysis was

conducted utilizing the theoretical cracked moment of inertia for I_y ; computing I_x based upon the cracked slab thickness; and letting $I_{xe} = I_x$. The plotted results indicate excellent correlation in the uncracked region and emphasize the effect of cracking and subsequent shear bond failure on the load carrying capacity of the slab.

Figure 9 compares the predicated and actual behavior of one of Porter and Ekberg's⁽⁶⁾ steel-deck-reinforced slabs subjected to two-way bending. The particular slab shown had no supplementary reinforcement and was simply supported on all four edges. The predicted and actual load vs. deflection curves show excellent agreement in the uncracked region of the initial load cycle. However, the effects of cracking are once again apparent in the final load cycle. Predicted deflections are actually lower bound values in the uncracked region as was indicated by the convergence study discussed earlier.

5. PARAMETRIC STUDY

A limited parametric study was conducted utilizing the previously discussed finite element model to examine the effects of various aspect ratios on the two-way flexural behavior of steel-deck-reinforced concrete slabs. The relative span lengths for the strong versus the weak direction of the orthotropic slab were of particular interest. Steel-deck-reinforced concrete slabs, when constructed as one-way systems, routinely have their ribs spanning the shorter direction, and current research⁽⁶⁾ into two-way behavior has generally followed this practice. In addition to aspect ratio, simply supported and fixed edge boundary conditions were examined.

5.1 Purpose and Scope

The relative distribution of bending moments and stresses in the two orthogonal directions corresponding to the strong and weak axes of a steel-deck-reinforced concrete slab is a function of aspect ratio, edge boundary conditions and the section and material properties of the particular slab in question. A finite element parametric study was conducted to quantify the effects of aspect ratio as well as the effect of simply supported versus fixed edge boundary conditions.

A typical steel-deck reinforced concrete slab section (Fig. 2) was selected and a finite element analysis was performed for each of the slab aspect ratios shown in Fig. 10. The relative span lengths were chosen so as to represent typical spans utilized in one-way steel deck-reinforced concrete slab construction as well as to represent

typical spans for alternate floor systems constructed of reinforced or precast concrete.

It is hypothesized that the optimum aspect ratio for a steel-deck-reinforced concrete slab is one in which the maximum concrete compressive stresses are equal in the main orthogonal directions of the slab. An expression for optimum aspect ratio is developed, based upon uncracked, elastic behavior, and is compared with the results of the parametric study.

5.2 Results

Deflection and moment coefficients are compared with slab aspect ratio in Figs. 11 and 12 respectively. Nondimensionalized coefficients for deflections and moments were developed based upon the corresponding expressions for one-way flexural behavior. In general terms, the coefficients are defined as follows:

$$\text{DEFLECTION COEFFICIENT} = \frac{384 \Delta EI}{w b^4} = \delta \quad 5.1$$

where Δ = center deflection; and

$$\text{MOMENT COEFFICIENT} = \frac{M}{w L^2} = \mu \quad 5.2$$

where M and L correspond to the appropriate weak or strong direction values. As shown in Figs. 11 and 12, the slab ribs span in the "b" direction (strong direction), and an aspect ratio of zero corresponds to one-way bending. For aspect ratios less than one the ribs span in the short direction and conversely, the ribs span in the long direction for aspect ratios greater than one.

Figure 11 indicates that for a given span "b", a significant reduction in maximum deflection can be realized by considering the effects of two-way flexural action, particularly in the case of simply supported edges. Although such reduction is more pronounced for the larger aspect ratios, a 25% reduction in maximum deflections is predicted for a simply supported slab with a 0.75 aspect ratio. A 12'x16' slab with ribs spanning 12 feet, as shown in Fig. 10, has an aspect ratio of 0.75 and is a typical panel used in current designs; however, the added benefit of two-way flexural action is generally neglected when computing the deflection of such a slab.

If an isotropic slab were considered, the plots of weak and strong axis moment coefficients shown in Fig. 12 would intersect at an aspect ratio of 1.0, and for the case of simple supports the maximum biaxial compressive stress would be balanced at the center. Assuming that an optimum two-way steel-deck-reinforced concrete slab design will also attempt to balance the maximum biaxial compressive stress in the concrete, an expression for the optimum aspect ratio was derived in Appendix C and is expressed as follows:

$$\left(\frac{b}{a}\right)_{opt} = \sqrt{\frac{S_y}{S_x} \left(\frac{\mu_{yy}}{\mu_{xx}}\right)} \quad 5.3$$

where μ_{xx} and μ_{yy} refer to the moment coefficients for the respective strong and weak direction moments. A trial and error solution for $\left(\frac{b}{a}\right)_{opt}$ utilizing values plotted in Fig. 12 is also shown in Appendix C for the simply supported case. A similar solution for fixed edges would require optimization with respect to either positive or negative bending moments.

The optimum aspect ratio for the simply supported case for the section shown in Fig. 2 was found to be approximately 1.1. This value indicates that steel-deck-reinforced concrete slabs subjected to two-way bending respond more efficiently if their aspect ratio is greater than one; that is if the ribs span in the longer direction. As mentioned previously, it is current practice to generally design steel-deck-reinforced concrete slabs as simple, one-way spans with the ribs spanning the short direction. The potential advantages of utilizing two-way simple or continuous spans are quite apparent from the comparisons illustrated in Fig. 12.

6. CONCLUSIONS AND RECOMMENDATIONS

The concept of designing steel-deck-reinforced concrete slabs as two-way flexural systems is technically feasible and suggests strong potential for significant economic advantages. Although this conclusion is drawn based upon a simplistic uncracked, linear elastic analysis, it is reasonable to assume that the same behavioral trends will persist in the cracked region and that the two-way steel-deck-reinforced concrete slab will performed consistently better than its one-way counterpart. Although Porter⁽⁶⁾ observed predominately one-way action of two-way steel-deck-reinforced concrete slabs at ultimate load, significant two-way action was observed at working load levels despite cracking of the slab cross section. Such behavior suggests the possibility of developing working stress design procedures utilizing linear elastic analysis of the cracked cross section at the working load level. Such analysis techniques are currently utilized in the design of one-way steel-deck-reinforced concrete slab systems. However, two-way design of such slab systems will necessarily require the utilization of supplementary reinforcement transverse and possibly parallel to the steel deck ribs. As Porter⁽⁶⁾ observed, such reinforcement, placed directly on the steel deck resulted in increased ultimate capacity when the slab was subjected to two-way bending. Supplementary reinforcement is required not only to resist bending moments, but also to maintain the same relative stiffness between the weak and strong axes of the cracked and uncracked cross section of the steel-deck-reinforced concrete slab.

As discussed in the parametric study, a two-way steel-deck reinforced slab will perform more efficiently if the ribs span in the longer direction. This observation and the theoretical prediction for optimum aspect ratio must necessarily be confirmed by actual experimentation.

The elastically orthotropic finite element model was found to perform both effectively and efficiently with a relatively coarse discretization. However, the model was particularly sensitive to the expression utilized for the orthotropic shear modulus G_{xy} and actual testing is required to further validate all model parameters. As mentioned in Art. 2.3, the model includes an "artificially high" bending rigidity in the weak direction; however, correlation with theoretical and experimental results supports the validity of the parameters which contribute to the model's weak direction bending rigidity.

The difficulties associated with premature shear bond failure as well as the structural adequacy of the steel-decking during the construction phase must necessarily be considered in any refined development of the concept of designing steel-deck-reinforced concrete slabs as two-way flexural systems. The relative shear-bond and flexural behavior of interior versus exterior floor panels in a general two-way framing scheme would be of particular interest.

Although the full benefits of two-way flexural behavior may be significantly limited by various physical or practical constraints,

the relative advantages of two-way versus one-way design of steel-deck-reinforced concrete slabs are quite apparent. Moreover, the increased efficiency of a two-way steel-deck-reinforced concrete slab, combined with the other numerous advantages inherent in this construction system, will significantly enhance its acceptability for utilization in multiunit residential facilities.

A considerable amount of additional research is required before a generally acceptable two-way design procedure could be promulgated. The analytical techniques developed in this report must be validated against specific test results and refined as necessary. A full scale testing program, which parallels and expands upon the parametric study included in this report, is also imperative. In particular, the following parameters should be examined:

- a. Concrete weight and strength
- b. Steel deck cross section and embossment pattern
- c. Slab and deck thickness
- d. Boundary conditions
- e. Aspect ratio, span length, and rib direction
- f. Loading
- g. Supplementary reinforcement

The required amount of supplementary reinforcement will significantly effect both the technical and economic feasibility of fully developing two-way flexural action, and should receive careful attention during the testing phase. Additionally, trial designs should be prepared for various sections and general economic comparisons should be made with

alternate floor systems of equivalent capacity to ascertain both the physical and economical efficiency of a steel-deck-reinforcement concrete slab.

Composite structural systems, in general, offer increased load carrying efficiency by utilizing each component material in its most effective manner and to its fullest potential. The steel-deck-reinforced concrete slab is currently under-utilized as a structural system; however, a much greater efficiency could be achieved by fully investigating and eventually taking advantage of two-way flexural behavior.

7. NOMENCLATURE

C_{xx}, C_{yy}, C_{xy}	plane stress elasticity constants
D_x, D_y	flexural rigidity constants
D_{xy}	torsional rigidity constant
E, E_c, E_s	modulus of elasticity (concrete; steel)
E_x, E_y	orthotropic modulus of elasticity
G_{xy}	orthotropic shear modulus
H	effective torsional rigidity constant; total steel-deck-reinforced slab depth
I	transformed uncracked moment of inertia
I_y	transformed uncracked strong axis moment of inertia per unit width
I_x	uncracked weak axis moment of inertia per unit width of slab of depth h
I_{xe}	effective uncracked weak axis moment of inertia per unit width
L	span length
M, M_{xx}, M_{yy}	moment per unit width
M_{xx}^{cs}, M_{yy}^{cs}	center moments per unit width for simply supported edges
M_{xx}^{cf}, M_{yy}^{cf}	center moments per unit width for fixed edges
M_{xx}^{ef}, M_{yy}^{ef}	edge moments per unit width for fixed edges
S_y, S_x	elastic section modulus
SS	simple support
a	weak direction span
a_1	modular width of steel-deck-reinforced concrete slab section

b	strong direction span
b/a	aspect ratio
f_{cx}, f_{cy}	concrete stress
f'_c	ultimate concrete strength
f_y	yield stress of steel
h	total depth of concrete above steel deck ribs
q, q_0	uniform load distribution (plate bending equations)
t	rib thickness
t_e	effective uniform thickness of the elastically orthotropic slab model
t_s	thickness of the steel deck
w	deflection surface; uniform load per unit area
w_c	weight of concrete
x, y	global coordinate axes
Δ	center deflection
Σ	finite summation
α	ratio of h/H ; deflection coefficient for orthotropic plate bending
β_1, β_2	moment coefficients for orthotropic plate bending
γ	coefficient of torsional rigidity
γ_{xy}	shear strain
δ	deflection coefficient
$\epsilon_{xx}, \epsilon_{yy}$	linear strain
μ, μ_{xx}, μ_{yy}	moment coefficients
ν, ν_c, ν_s	Poisson's ratio (concrete; steel)
ν_x, ν_y	orthotropic Poisson ratios

σ_{xx}, σ_{yy}

normal stress

τ_{xs}

shear stress (equals τ_{xy} for an orthotropic plate with principal axes of orthotropy coinciding with the x and y axes of the local coordinate system)

8. TABLES

Table 1 Section and Material Properties

Property	Value
I	278.7 in ⁴
I_y	23.2 in ⁴ /in
I_x	3.57 in ⁴ /in
I_{xe}	4.63 in ⁴ /in
S_y	7.864 in ³ /in
S_x	2.427 in ³ /in
f'_c	3000 psi
w_c	150 pcf
E_c	3320 ksi
ν_c	0.2
f_y	36 ksi
E_s	29,500 ksi
ν_s	0.3
t_s	0.0359 in (20 gage)

Table 2 Constants for a Simply Supported Rectangular
Orthotropic Plate with $H = \sqrt{\frac{D_x}{D_y}}$ (10)

ϵ	α	β_1	β_2
1.0	0.00407	0.0368	0.0368
1.1	0.00488	0.0359	0.0477
1.2	0.00565	0.0344	0.0524
1.3	0.00639	0.0324	0.0597
1.4	0.00709	0.0303	0.0665
1.5	0.00772	0.0280	0.0728
1.6	0.00831	0.0257	0.0785
1.7	0.00884	0.0235	0.0837
1.8	0.00932	0.0214	0.0884
1.9	0.00974	0.0191	0.0929
2.0	0.01013	0.0174	0.0964
2.5	0.01150	0.0099	0.1100
3.0	0.01223	0.0055	0.1172
4.0	0.01282	0.0015	0.1230
5.0	0.01297	0.0004	0.1245
∞	0.01302	0.0000	0.1250

Table 3 Comparison of Theoretical and Finite Element Model Results

Notes: Ribs span in b direction (see Fig. 10, case B)

Simply supported edges

$q_0 = .001$ ksi (144 psf)

Aspect Ratio (b/a)	Deflections (in)		Strong Direction			Weak Direction			
	Theory	SAP	Ratio*	Theory	SAP	Ratio*	Theory	SAP	Ratio*
1.333	0.0880	0.0847	0.963	1.809	1.725	0.954	0.722	0.800	1.108
1.000	0.1345	0.1335	0.993	2.748	2.712	0.987	0.825	0.713	0.864
0.667	0.1894	0.1922	0.985	3.832	3.884	1.014	0.783	0.454	0.580
0.500	0.2145	0.2157	1.006	4.326	4.345	1.004	0.686	0.296	0.431

$$*Ratio = \frac{SAP}{theory}$$

**If the theoretical effects of transverse contraction are neglected M_{yy}^{CS} is as follows:

$$a/b = 0.667 \quad M_{yy}^{CS} = 0.517 \quad ratio = 0.878$$

$$a/b = 0.500 \quad M_{yy}^{CS} = 0.282 \quad ratio = 0.953$$

9. FIGURES

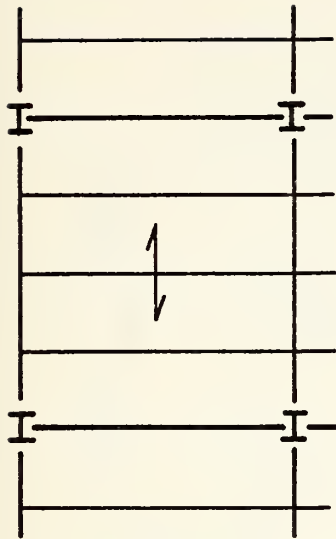

Plan View

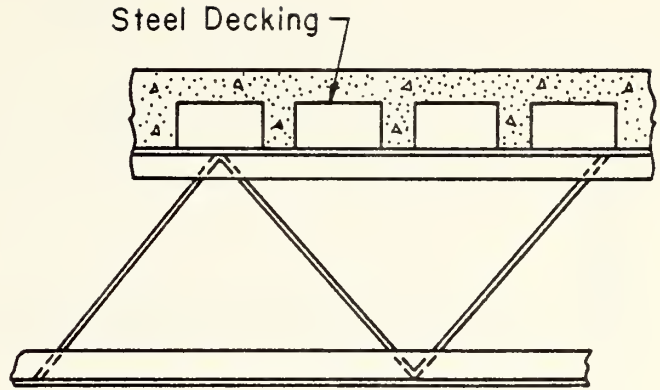

Section

(a) One-Way Steel-Deck-Reinforced Concrete Slab

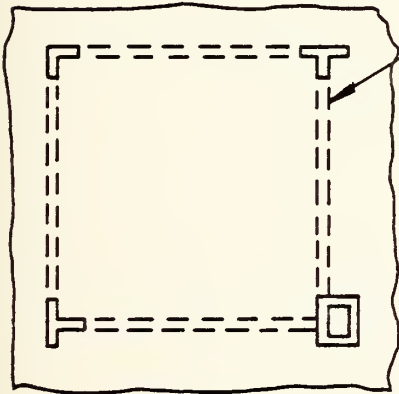

Plan View

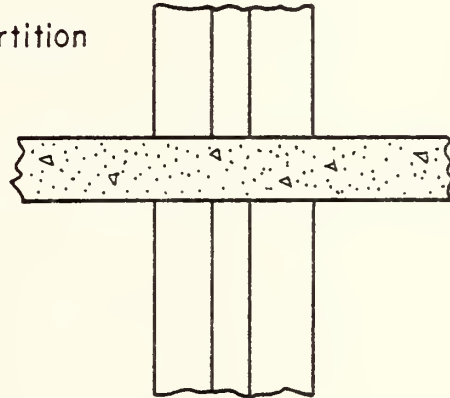

Section

(b) Two-Way Flat Plate Concrete Slab

Fig. 1 Alternate Conventional Floor Systems

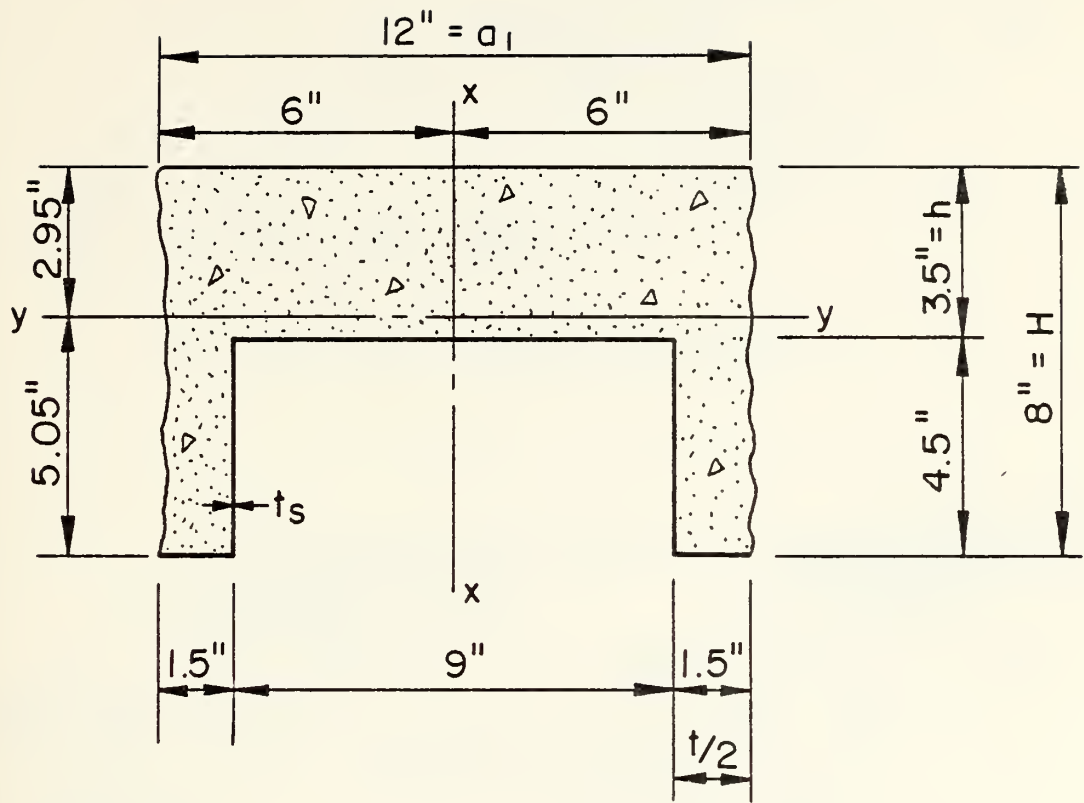
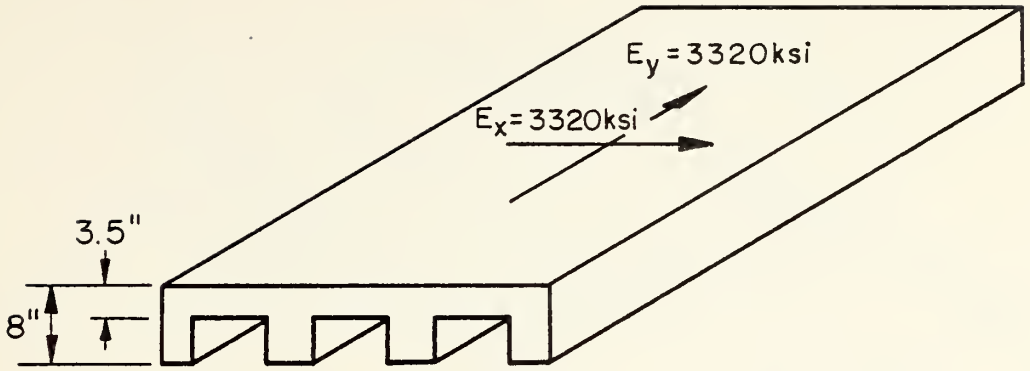
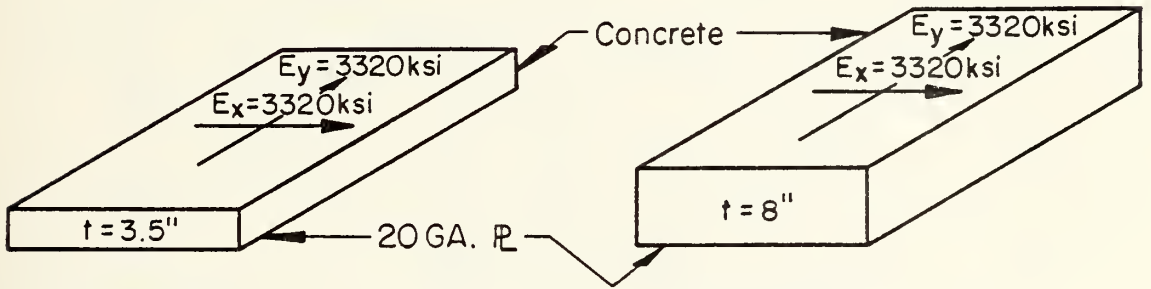

Fig. 2 Typical Cross-Section



(a) Actual Slab - Structurally Orthotropic



(b) Lower Bound

(c) Upper Bound

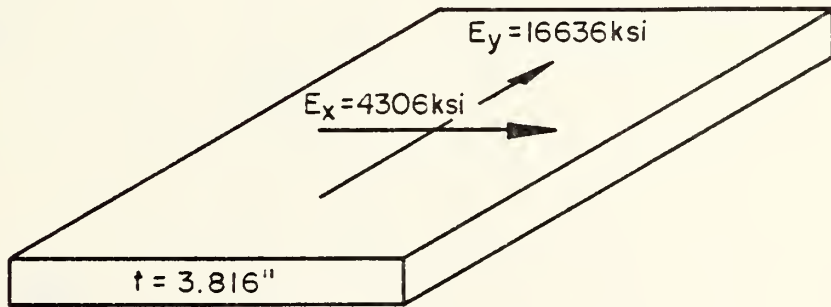

(d) Slab Model - Elastically Orthotropic

Fig. 3 Model Development

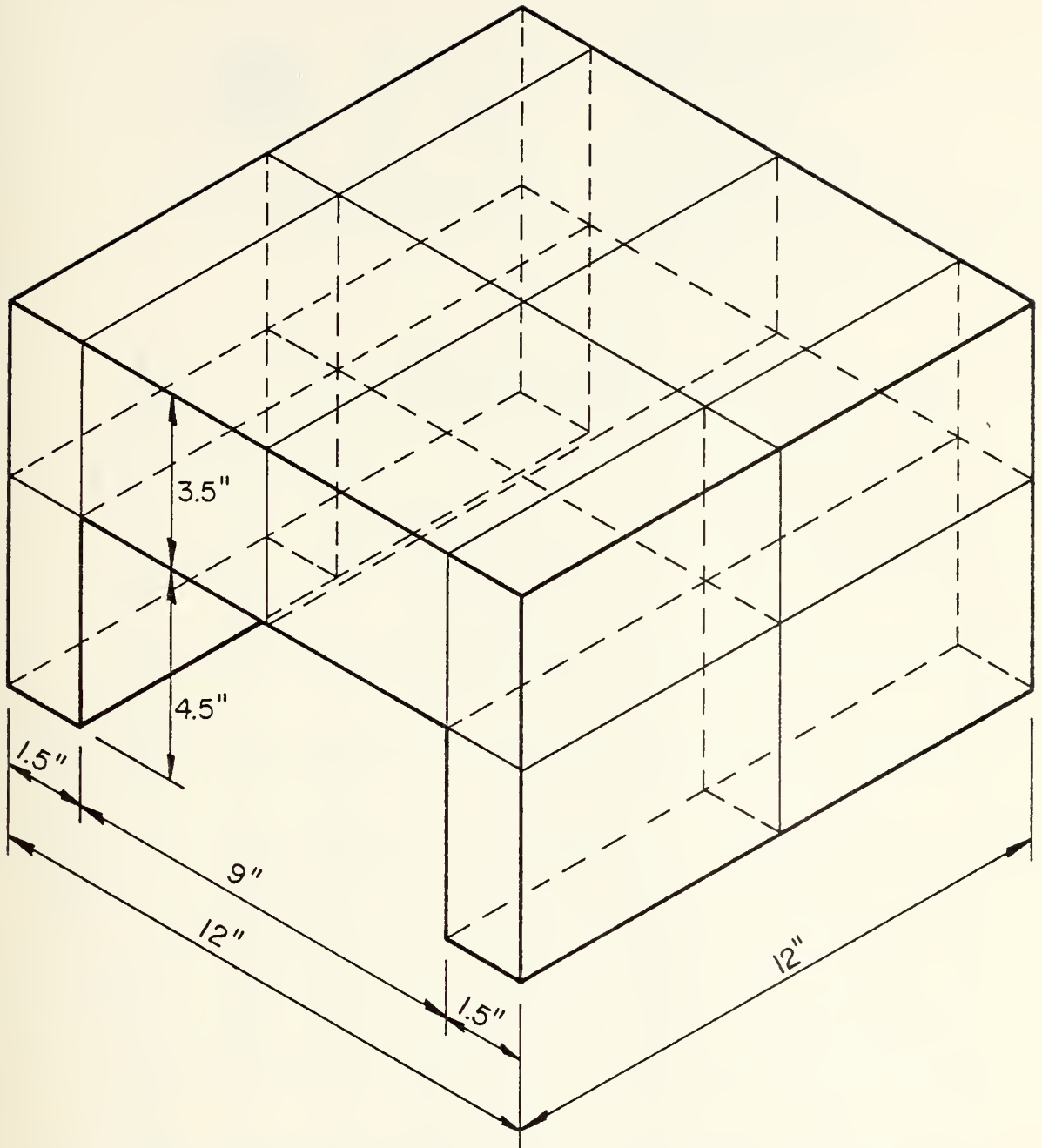

43 - Nodal Points

12 - 8-Node Bricks (concrete)

12 - Plate Bending Elements (steel deck)

Fig. 4 Structurally Orthotropic Finite Element Model

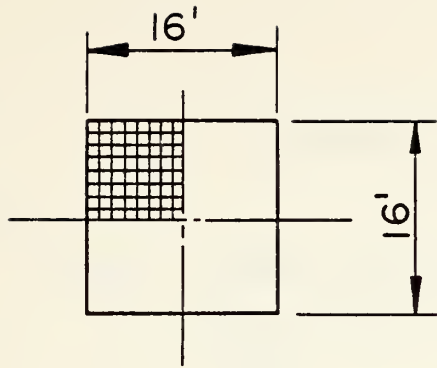

- Quarter Symmetry Utilized in Model Discretization
- 81 Nodal Points
- 64 Plate Bending Elements

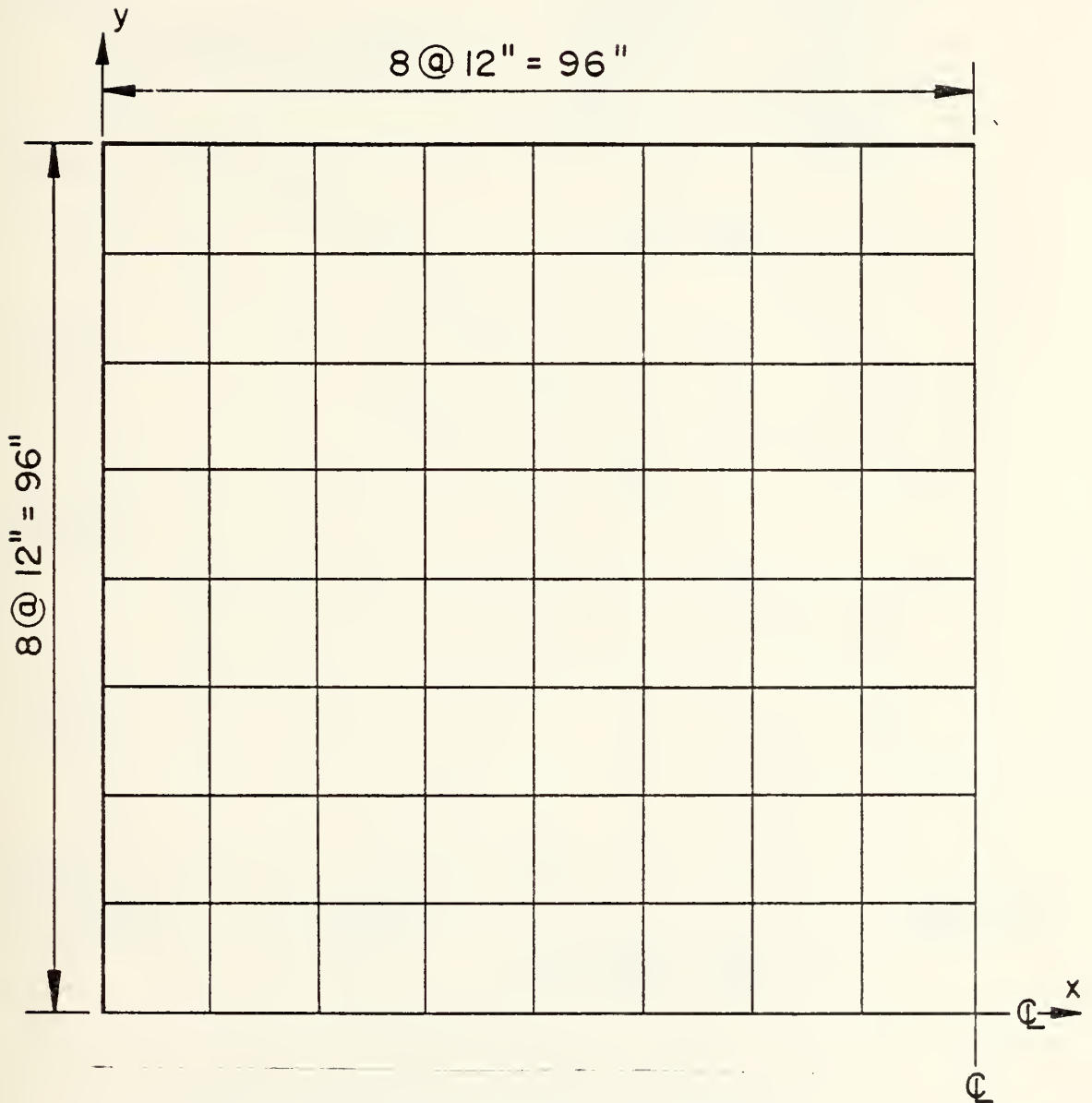

Fig. 5 Typical Finite Element Model Discretization

Δ Center vs. Element Size

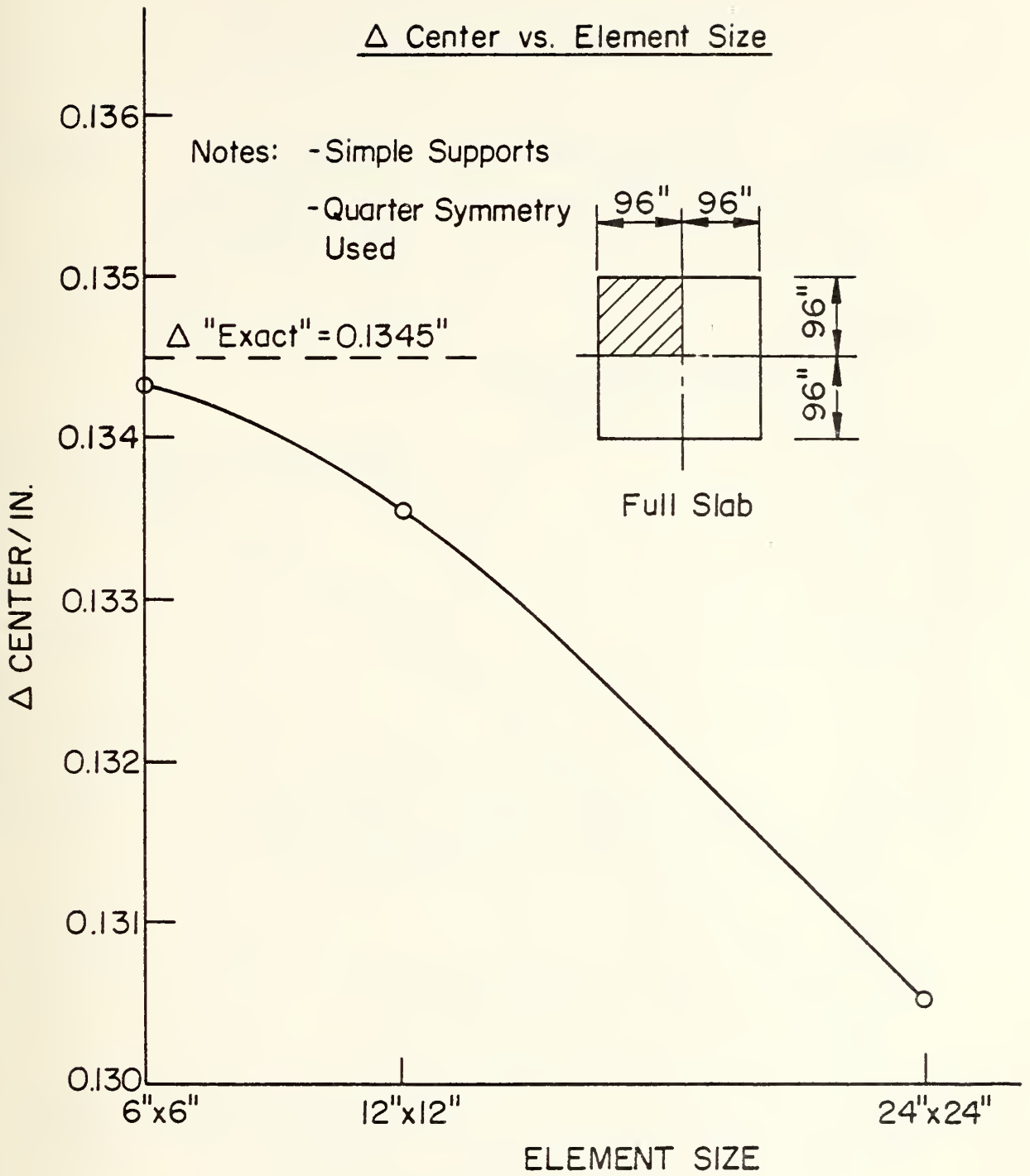

Fig. 6 Convergence Study - Deflections

Maximum Moments vs. Element Size

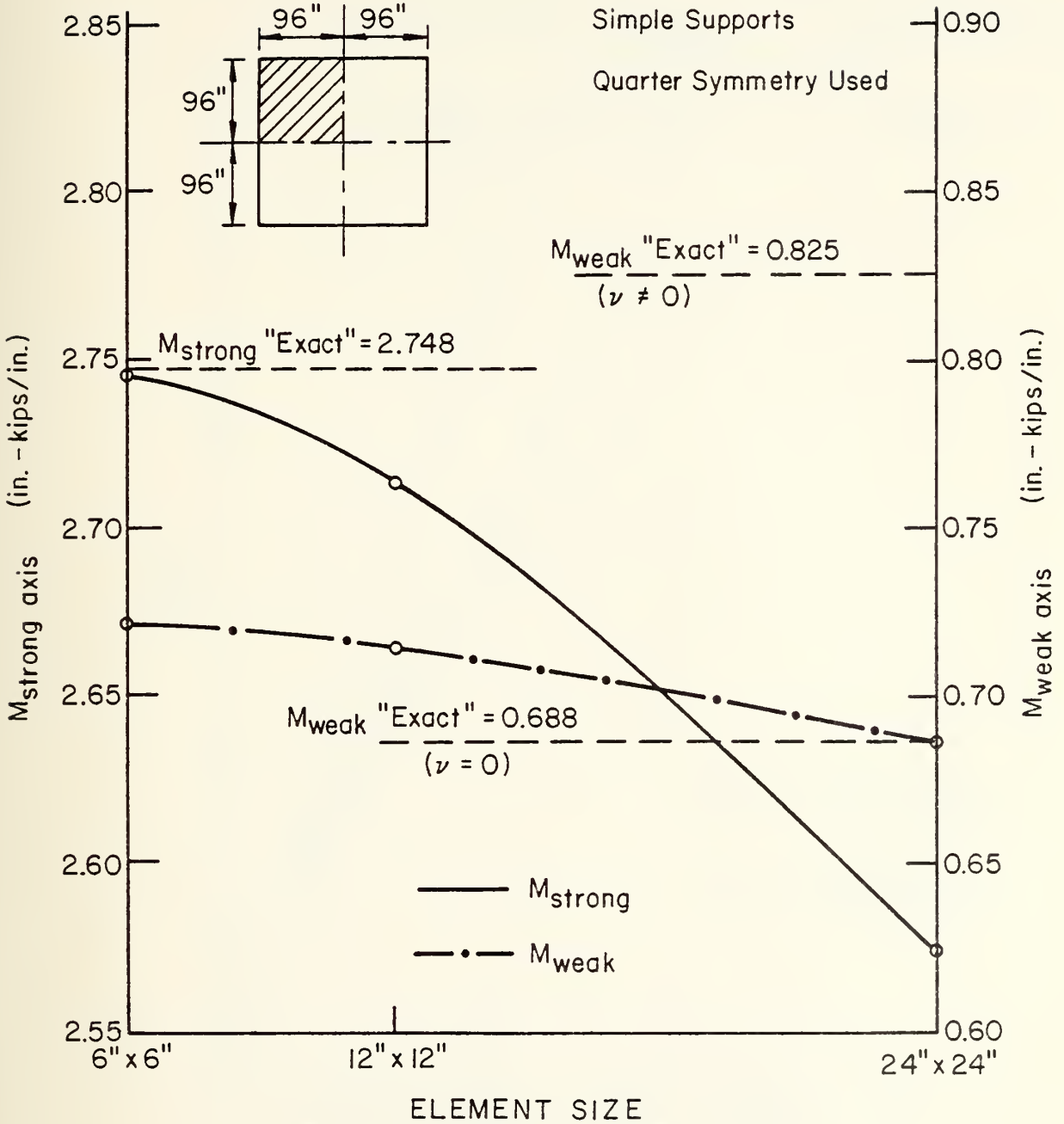

Fig. 7 Convergence Study - Moments

Load vs. Centerline Deflection
 Schuster & Ekberg Beam 8I16-70-19-19SG

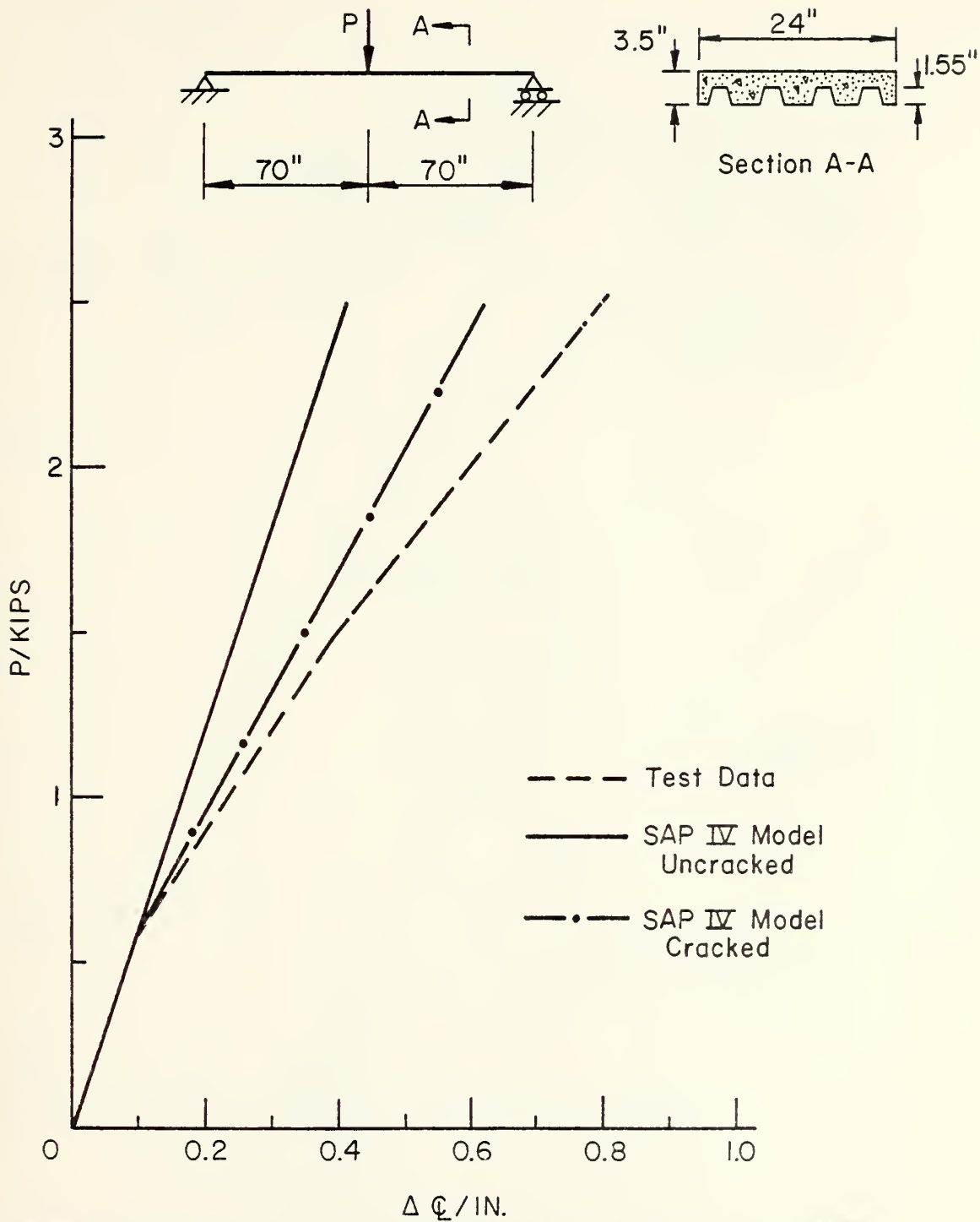

Fig. 8 Comparison of Model and Test Results (One-way Bending)

Load vs. Center Deflection
Porter & Ekberg Two-Way Slab No. 3

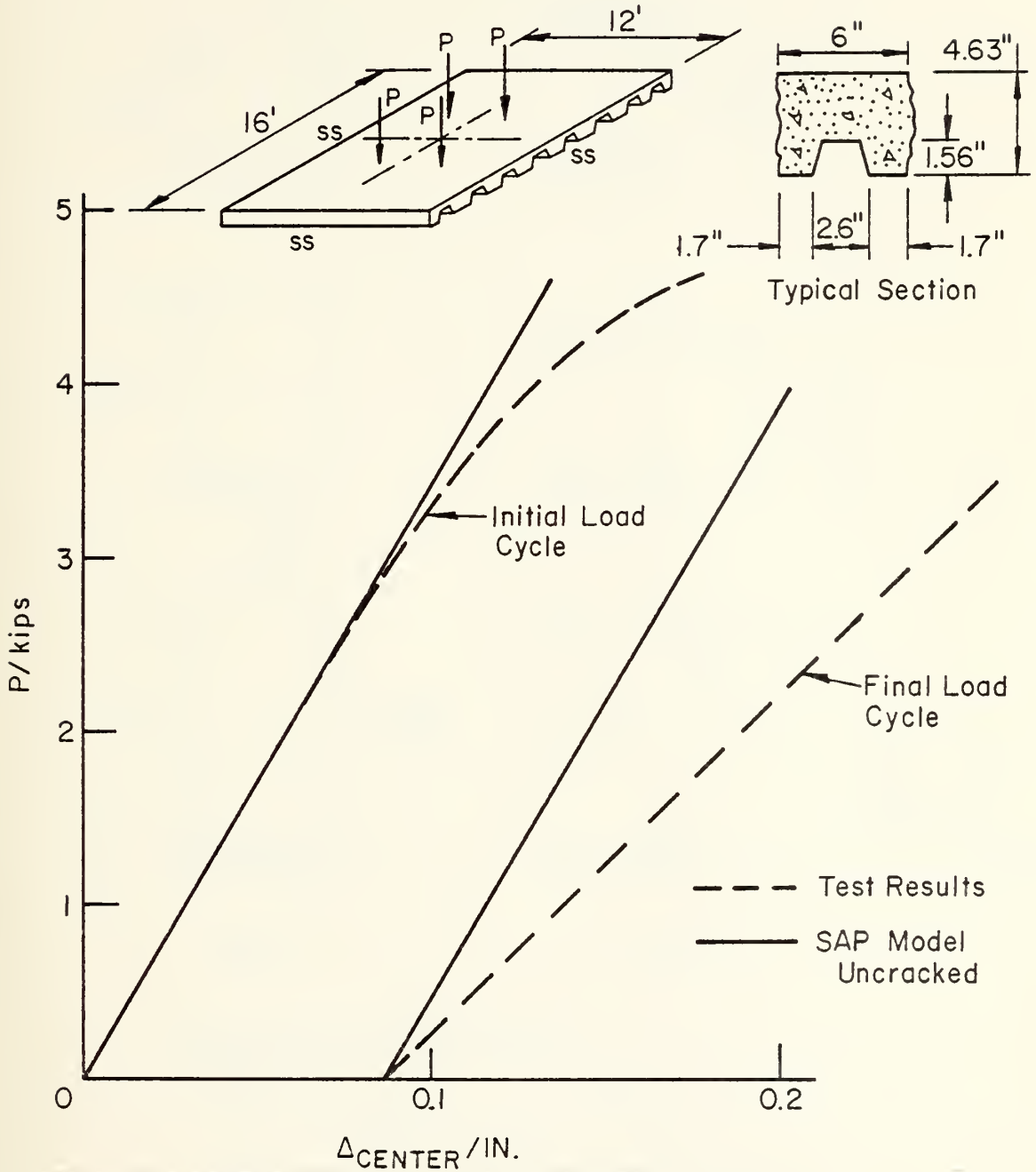
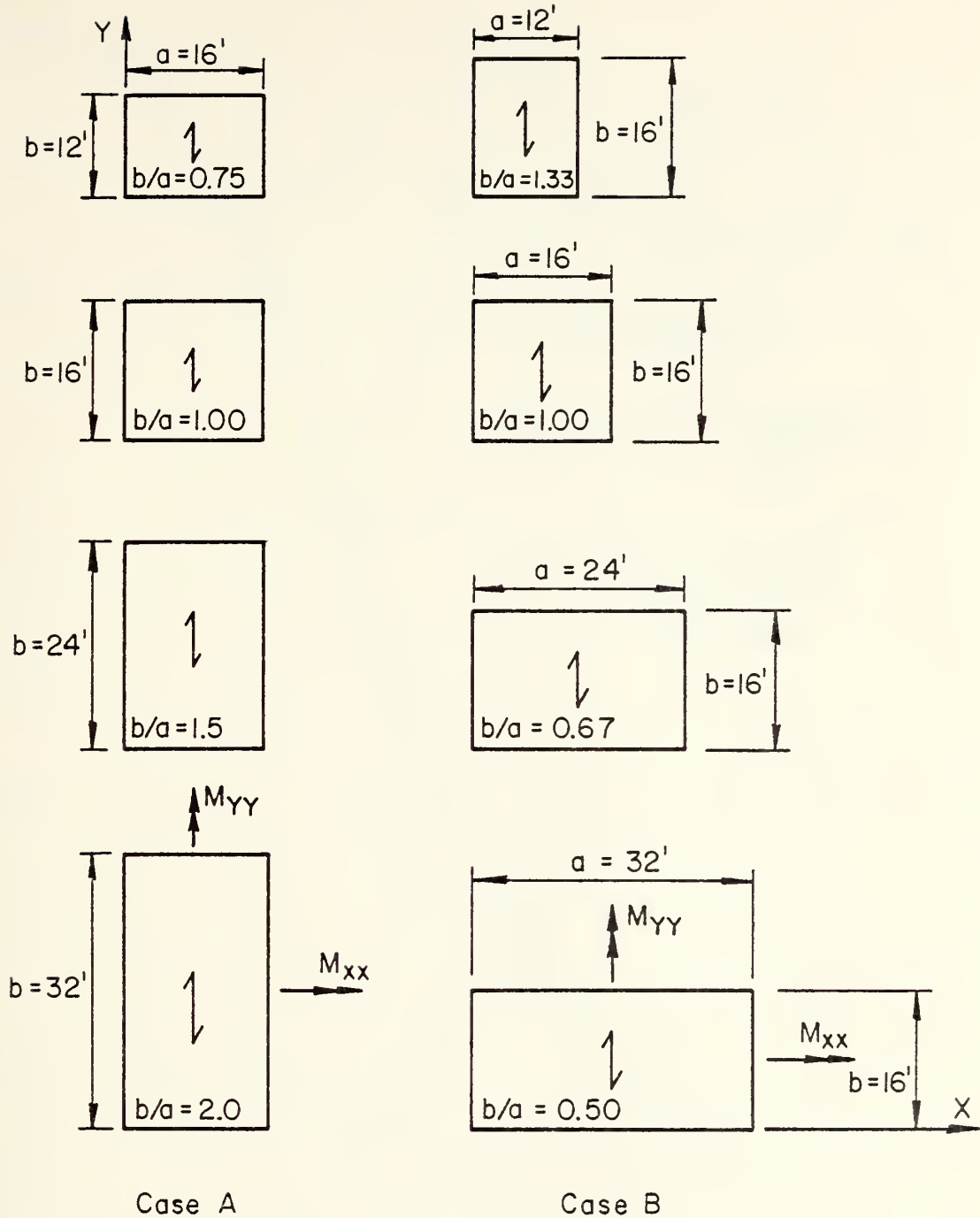

Fig. 9 Comparison of Model and Test Results (Two-way Bending)



Ribs Span in "b" Direction

Fig. 10 Aspect Ratio Parametric Study

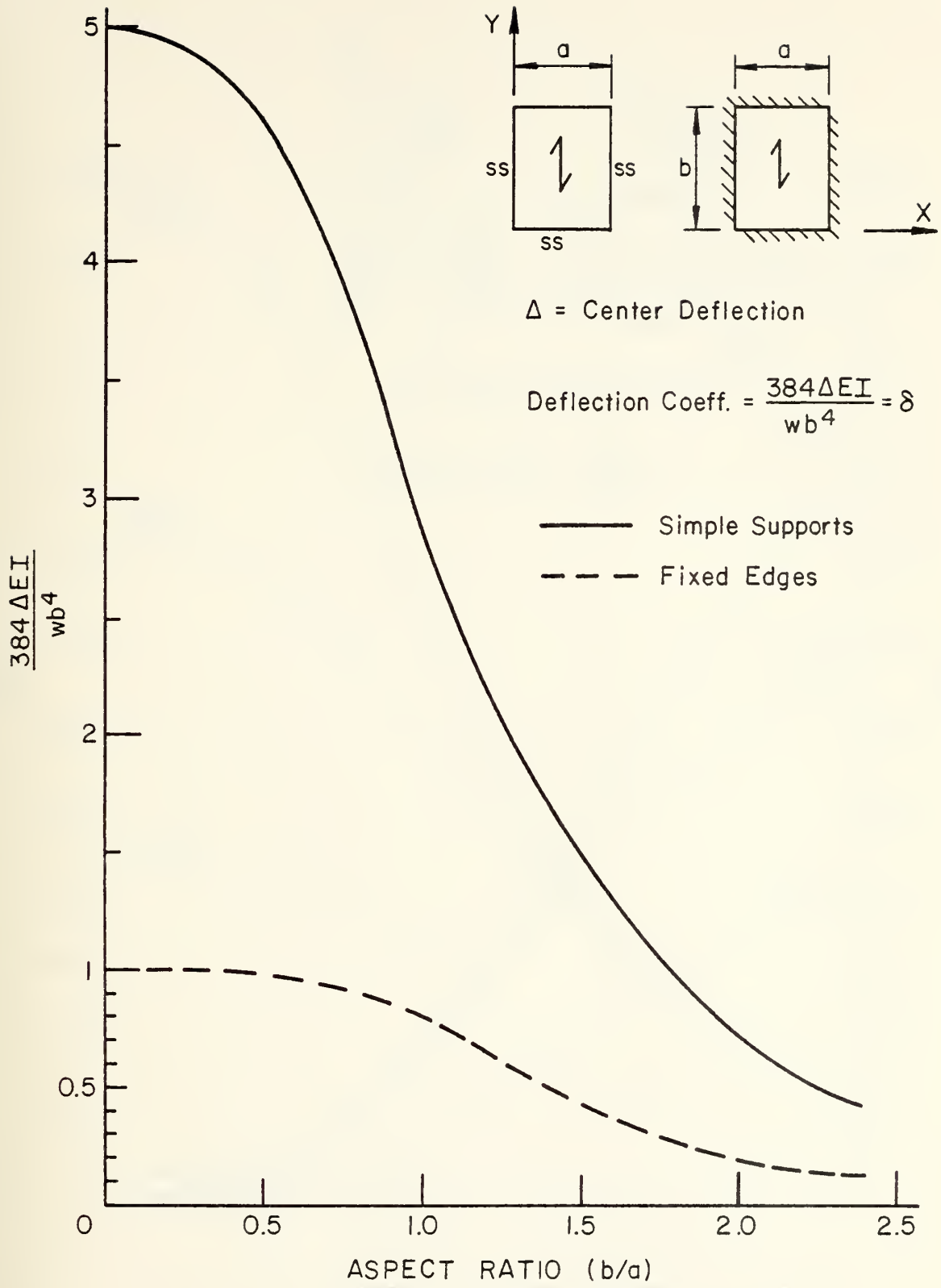

Fig. 11 Deflection Coefficient vs. Aspect Ratio

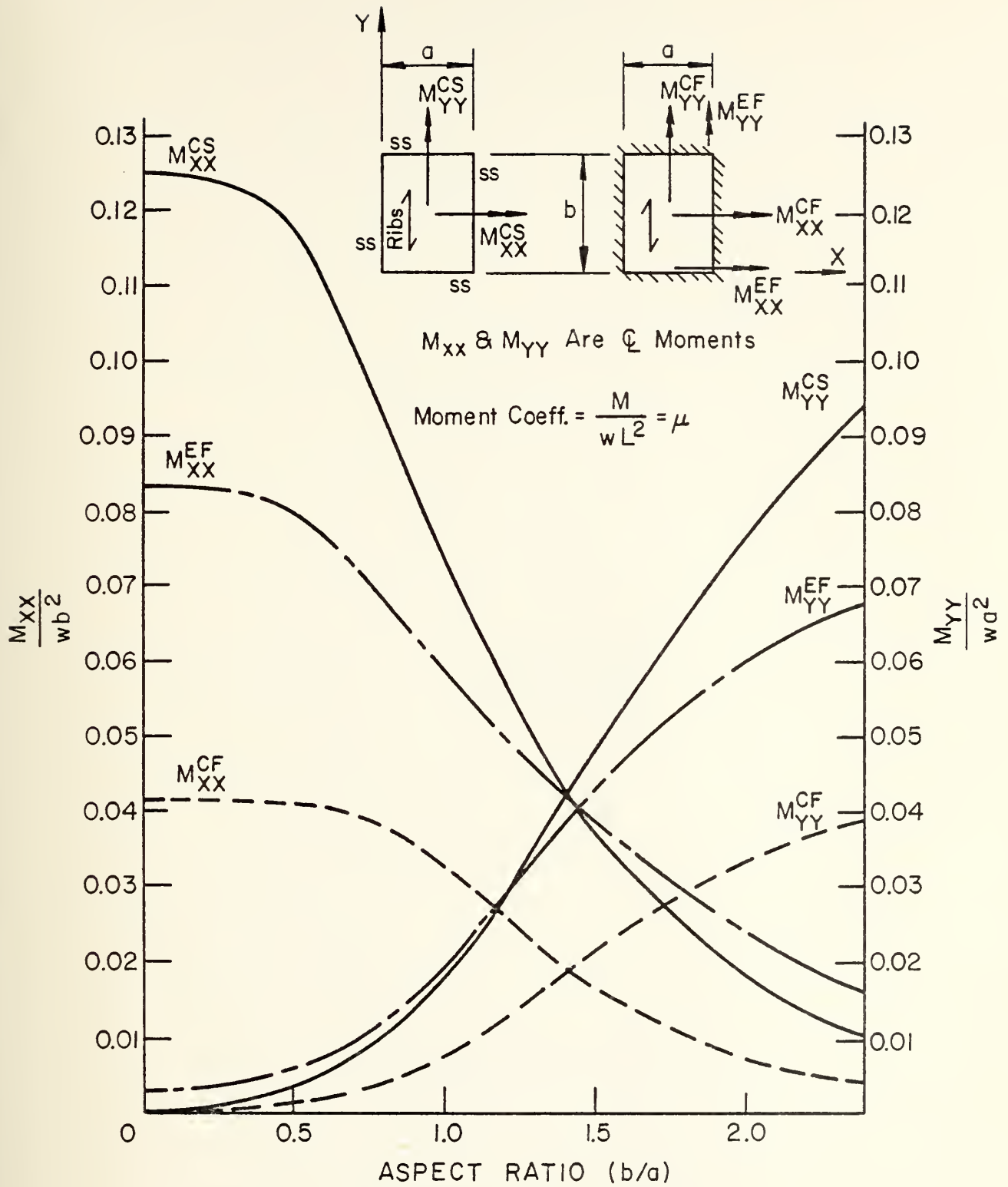

Fig. 12 Moment Coefficients vs. Aspect Ratio (Simple Support & Fixed Edges)

10. APPENDICES

APPENDIX A: COMPUTATION OF MODEL PARAMETERS

$$I_x = 3.57 \text{ in}^4/\text{in}$$

$$I_y = 23.2 \text{ in}^4/\text{in}$$

$$E_c = 33(w_c)^{1.5} \sqrt{f_c} = 3320 \text{ ksi}$$

$$\nu_c = 0.2 \text{ (assumed)}$$

$$I_{xe} = \frac{a_1 h^3}{12(a_1 - t - \alpha^3 t)} = \frac{12(3.5)^3}{12\left(12 - 3 + \left(\frac{3.5}{8}\right)^3 (3)\right)} = 4.63 \text{ in}^4/\text{in}$$

$$E_x = \frac{I_{xe}}{I_x} (E_c) = \frac{4.63}{3.57} (3320) = 4306 \text{ ksi}$$

$$E_y = \frac{I_y}{I_{xe}} (E_c) = \frac{23.2}{4.63} (3320) = 16636 \text{ ksi}$$

$$\nu_x = \frac{I_{xe}}{I_y} (\nu_c) = \frac{4.63}{23.2} (0.2) = 0.0399$$

$$\nu_y = \frac{I_x}{I_{xe}} (\nu_c) = \frac{3.57}{4.63} (0.2) = 0.1542$$

$$C_{xx} = \frac{E_x}{1 - \nu_x \nu_y} = \frac{4306}{1 - .0399(.1542)} = 4333 \text{ ksi}$$

$$C_{yy} = \frac{E_y}{1 - \nu_x \nu_y} = \frac{16636}{1 - .0399(.1542)} = 16739 \text{ ksi}$$

$$C_{xy} = \frac{\sqrt{\nu_x \nu_y E_y E_x}}{1 - \nu_x \nu_y} = \frac{\sqrt{(0.1542)(0.0399)(16636)(4306)}}{1 - .0399(.1542)}$$

$$C_{xy} = 668 \text{ ksi}$$

$$G_{xy} = \frac{E_x E_y}{E_x + (1+2\nu_x) E_y} = \frac{4306(16636)}{4306 + (1+2(.0399))(16636)}$$

$$G_{xy} = 3217 \text{ ksi}$$

$$t_e = \sqrt[3]{12 \bar{I}_{xe}} = \sqrt[3]{12(4.63)} = 3.816 \text{ in.}$$

APPENDIX B: COMPUTATION OF THEORETICAL DEFLECTIONS AND MOMENTS

$$a = b = 16 \text{ ft} = 192 \text{ in. (simply supported edges)}$$

$$q_o = 0.001 \text{ ksi (144 psf)}$$

$$C_{xx} = 4333 \text{ ksi}$$

$$E = E_c = 3320 \text{ ksi}$$

$$C_{yy} = 16739 \text{ ksi}$$

$$\nu_x = 0.0399$$

$$C_{xy} = 668 \text{ ksi}$$

$$\nu_y = 0.1542$$

$$D_x = \frac{E a_1 h^3}{(1-\nu_y^2)(12)(a_1 - t + \alpha^3 t)} = \frac{3320 (12) (3.5)^3}{(1-0.1542^2)(12)\left(12 - 3 + \left(\frac{3.5}{8}\right)^3 (3)\right)}$$

$$D_x = 15761 \text{ in-kip}$$

$$D_y = \frac{E I}{(1-\nu_x^2)(a_1)} = \frac{3320 (278.7)}{(1-0.0399^2)(12)} = 77230 \text{ in-kip}$$

$$\epsilon = \frac{a}{b} \sqrt[4]{\frac{D_y}{D_x}} = \frac{192}{192} \sqrt[4]{\frac{77230}{15761}}$$

$$\epsilon = 1.488$$

From Table 1: $\alpha = 0.007644$

$$\beta_1 = 0.028276$$

$$\beta_2 = 0.072044$$

$$w = \frac{\alpha q_o b^4}{D_y} = \frac{0.007644 (.001) (192)^4}{77230}$$

$$\underline{\underline{w = 0.1345 \text{ in.}}}$$

$$M_{xx} = \left(\beta_2 + \beta_1 \frac{C_{xy}}{C_{yy}} \sqrt{\frac{D_y}{D_x}} \right) q_o b^2$$

$$M_{xx} = \left(0.072044 + 0.028276 \left(\frac{668}{16739} \right) \sqrt{\frac{77230}{15761}} \right) .001 (192)^2$$

$$\underline{\underline{M_{xx} = 2.748 \text{ in-kip/in}}}$$

$$M_{yy} = \left(\beta_1 + \beta_2 \frac{C_{xy}}{C_{xx}} \sqrt{\frac{D_x}{D_y}} \right) \frac{q_o a^2}{e}$$

$$M_{yy} = \left(0.028276 + 0.072044 \left(\frac{668}{4333} \right) \sqrt{\frac{15761}{77230}} \right) \frac{.001 (192)^2}{1.488}$$

$$\underline{\underline{M_{yy} = 0.825 \text{ in-kip/in}}}$$

Note: If transverse contractions are neglected ($v_x = v_y = C_{xy} = 0$), deflections and moments are similarly computed as follows:

$$w = 0.1361 \text{ in}$$

$$M_{xx} = 2.684 \text{ in-kip/in}$$

$$M_{yy} = 0.688 \text{ in-kip/in}$$

APPENDIX C: OPTIMUM ASPECT RATIO (see Fig. 12)

For uncracked, linear elastic behavior:

$$f_{cx} = \frac{M_{yy}}{S_x} \qquad f_{cy} = \frac{M_{xx}}{S_y} \qquad (1)$$

Let $f_{cx} = f_{cy}$; therefore

$$\frac{M_{yy}}{S_x} = \frac{M_{xx}}{S_y} \qquad (2)$$

From Eq. 5.2:

$$M = \mu w L^2 \qquad (3)$$

Therefore

$$\frac{\mu_{yy} w a^2}{S_x} = \frac{\mu_{xx} w b^2}{S_y} \qquad (4)$$

After simplification:

$$\left(\frac{b}{a}\right)_{opt} = \sqrt{\frac{S_y}{S_x} \left(\frac{\mu_{yy}}{\mu_{xx}}\right)} \qquad 5.3$$

A trial and error solution for the optimum aspect ratio for a rectangular, simply supported slab with typical section as shown in Fig. 2 is included hereafter:

$$\frac{b}{a} = \sqrt{\frac{7.864}{2.427} \left(\frac{\mu_{yy}}{\mu_{xx}}\right)}$$

$$\frac{b}{a} = 1.8 \sqrt{\frac{\mu_{yy}}{\mu_{xx}}}$$

$$\frac{\mu_{yy}}{\mu_{xx}} = \left(\frac{b/a}{1.8}\right)^2 \qquad (5)$$

Aspect Ratio (b/a)	μ_{yy}/μ_{xx}	
	Computed from Eq. (5)	Computed from Fig. 12
1.00	0.309	0.262
2.00	1.235	4.114
1.50	0.694	1.310
1.33	0.594	0.825
1.25	0.482	0.660
1.10	0.373	0.377

$$\left(\frac{b}{a}\right)_{\text{opt}} = 1.1$$

11. REFERENCES

1. Bathe, K. J., Wilson, E. L. and Peterson, F. E.
SAP IV A STRUCTURAL ANALYSIS PROGRAM FOR STATIC AND DYNAMIC RESPONSE OF LINEAR SYSTEMS, University of California, Berkeley, Revised, April 1974.
2. Schuster, R. M. and Ekberg, C. E., Jr.
COMMENTARY ON THE TENTATIVE RECOMMENDATIONS FOR THE DESIGN OF COLD-FORMED STEEL DECKING AS REINFORCEMENT FOR CONCRETE FLOOR SLABS, Engineering Research Institute, Iowa State University, Ames, August 1970.
3. Schuster, R. M.
COMPOSITE STEEL-DECK CONCRETE FLOOR SYSTEMS, Journal of the Structural Division, ASCE, Vol. 102, No. ST5, May 1976.
4. Porter, M. L. and Ekberg, C. E., Jr.
DESIGN RECOMMENDATIONS FOR STEEL DECK FLOOR SLABS, Journal of the Structural Division, ASCE, Vol. 102, No. ST11, November 1976.
5. Porter, M. L. and Ekberg, C. E., Jr.
SHEAR-BOND ANALYSIS OF STEEL-DECK-REINFORCED SLABS, Journal of the Structural Division, ASCE, Vol. 102, No. ST12, December 1976.
6. Porter, M. L. and Ekberg, C. E., Jr.
BEHAVIOR OF STEEL-DECK-REINFORCED SLABS, Journal of the Structural Division, ASCE, Vol. 102, No. ST3, March 1977.
7. H. H. Robertson Company
Q-FLOOR SYSTEMS: TECHNICAL DATA GUIDE Q-147TD-75, Pittsburgh, Pa., January 1975.
8. Troitsky, M. S.
ORTHOTROPIC BRIDGES THEORY AND DESIGN, The James F. Lincoln Arc Welding Foundation, Cleveland, Oh., August 1967.
9. Szilard, R.
THEORY AND ANALYSIS OF PLATES, Prentice-Hall, Inc., New Jersey, 1974.
10. Timoshenko, S. P. and Woinowsky-Krieger, S.
THEORY OF PLATES AND SHELLS, 2nd Edition, McGraw-Hill, New York, 1959.

177907

Thesis
K87628
c.1

Kubic

Two-way flexural
behavior of steel-
deck-reinforced con-
crete slabs.

7

Thesis
K87628
c.1

Kubic

177907

Two-way flexural
behavior of steel-
deck-reinforced con-
crete slabs.

mesk8/628

Two-way flexural behavior of steel-deck-



3 2768 002 11555 2

DUDLEY KNOX LIBRARY