













ANNUAL REPORT  
OF THE  
BOARD OF REGENTS  
OF THE  
SMITHSONIAN INSTITUTION,

SHOWING  
THE OPERATIONS, EXPENDITURES, AND CONDITION  
OF THE INSTITUTION

FOR  
THE YEAR ENDING JUNE 30, 1901.



WASHINGTON:  
GOVERNMENT PRINTING OFFICE.

1902.

78072

W

~~Q~~

Q

11

, 566



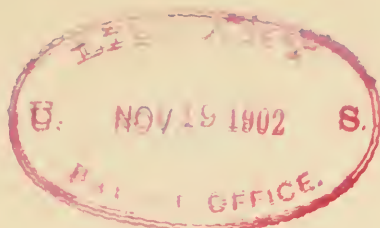

LETTER

FROM THE

SECRETARY OF THE SMITHSONIAN INSTITUTION,

ACCOMPANYING

*The Annual Report of the Board of Regents of the Institution for  
the year ending June 30, 1901.*

---

SMITHSONIAN INSTITUTION,

*Washington, D. C., January 30, 1902.*

*To the Congress of the United States:*

In accordance with section 5593 of the Revised Statutes of the United States, I have the honor, in behalf of the Board of Regents, to submit to Congress the Annual Report of the operations, expenditures, and condition of the Smithsonian Institution for the year ending June 30, 1901.

I have the honor to be, very respectfully, your obedient servant,

S. P. LANGLEY,

*Secretary of the Smithsonian Institution.*

HON. WILLIAM P. FRYE,

*President pro tempore of the Senate.*

# ANNUAL REPORT OF THE SMITHSONIAN INSTITUTION FOR THE YEAR ENDING JUNE 30, 1901.

---

## SUBJECTS.

1. Proceedings of the Board of Regents for the session of January 23, 1901.

2. Report of the executive committee, exhibiting the financial affairs of the Institution, including a statement of the Smithsonian fund, and receipts and expenditures for the year ending June 30, 1901.

3. Annual report of the Secretary, giving an account of the operations and condition of the Institution for the year ending June 30, 1901, with statistics of exchanges, etc.

4. General appendix, comprising a selection of miscellaneous memoirs of interest to collaborators and correspondents of the Institution, teachers, and others engaged in the promotion of knowledge. These memoirs relate chiefly to the calendar year 1901.

## CONTENTS.

---

	Page.
Letter from the Secretary, submitting the Annual Report of the Regents to Congress.....	III
General subjects of the Annual Report.....	IV
Contents of the Report .....	V
List of Plates.....	VIII
Members <i>ex officio</i> of the Establishment.....	XI
Regents of the Smithsonian Institution .....	XII
PROCEEDINGS OF THE BOARD OF REGENTS.	
Stated meeting January 23, 1901.....	XIII
REPORT OF THE EXECUTIVE COMMITTEE for the year ending June 30, 1901.	
Condition of the fund July 1, 1901 .....	XXV
Receipts and expenditures for the year.....	XXVI
Appropriation for International Exchanges .....	XXVII
Details of expenditures of same.....	XXVII
Appropriation for American Ethnology .....	XXVIII
Details of expenditures of same.....	XXIX
Appropriations for the National Museum.....	XXX
Details of expenditures of same.....	XXX
Appropriation for Astrophysical Observatory .....	XLVIII
Details of expenditures of same .....	XLVIII
Appropriation for Observation of Solar Eclipse.....	XLIX
Details of expenditures of same.....	XLIX
Appropriation for the National Zoological Park.....	XLIX
Details of expenditures of same.....	L
Recapitulation .....	LIV
General summary .....	LVI
ACTS AND RESOLUTIONS OF CONGRESS relative to Smithsonian Institution, etc..	LVII

---

### REPORT OF THE SECRETARY.

THE SMITHSONIAN INSTITUTION.....	1
The Establishment .....	1
Board of Regents.....	2
Appointment of Regents.....	7
Administration.....	7
Buildings .....	8
Finances.....	8
Research .....	11
Hodgkins fund.....	11
Naples table.....	15
Explorations .....	18

THE SMITHSONIAN INSTITUTION—Continued.		Page.
Publications.....		18
Library.....		21
International Catalogue of Scientific Literature.....		23
Correspondence.....		25
Expositions.....		26
Miscellaneous.....		26
National Museum.....		29
Bureau of American Ethnology.....		36
National Zoological Park.....		38
Astrophysical Observatory.....		44
International Exchanges.....		48
Necrology.....		51
Appendixes:		
I. Report on the United States National Museum.....		53
II. Report on the Bureau of American Ethnology.....		65
III. Report on the International Exchange Service.....		85
IV. Report on the National Zoological Park.....		105
V. Report on the Astrophysical Observatory.....		119
VI. Report of the Librarian.....		126
VII. Report of the Editor.....		129

---

#### GENERAL APPENDIX.

The Smithsonian Institution.....	145
Some Recent Astronomical Events, by C. G. Abbot.....	153
A Model of Nature, by A. W. Rücker.....	171
A Century of the Study of Meteorites, by Oliver C. Farrington.....	193
Recent Studies in Gravitation, by John H. Poynting.....	199
On Ether and Gravitational Matter through Infinite Space, by Lord Kelvin ..	215
On Bodies Smaller than Atoms, by J. J. Thomson.....	231
The Exploration of the Atmosphere at Sea by Means of Kites, by A. Lawrence Rotch.....	245
Solid Hydrogen, by James Dewar.....	251
Utilizing the Sun's Energy, by Robert H. Thurston.....	263
The New Radiations—Cathode Rays and Röntgen Rays, by A. Dastre.....	271
Wireless Telegraphy, by G. Marconi.....	287
Transatlantic Telephoning, by William A. Anthony.....	299
The Telephonograph, by William J. Hammer.....	307
Color Photography, by Sir William J. Herschel.....	313
The History of Chronophotography, by Dr. J. Marey.....	317
The Aims of the National Physical Laboratory of Great Britain, by R. T. Glazebrook.....	341
Emigrant Diamonds in America, by William Herbert Hobbs.....	359
Bogoslof Volcanoes, by C. Hart Merriam.....	367
The Antarctic Voyage of the Belgica during the Years 1897, 1898, and 1899, by Henryk Arctowski.....	377
The Sea in the Life of the Nations, by Alfred Kirchoff.....	389
Forest Destruction, by Gifford Pinchot and C. Hart Merriam.....	401
Irrigation, by F. H. Newell.....	407
The Palace of Minos, by Arthur J. Evans.....	425
The Engraved Pictures of the Grotto of La Mouthe (Dordogne), by Emile Rivière.....	439

	Page.
The Mind of Primitive Man, by Franz Boas.....	451
Traps of the American Indians—A Study in Psychology and Invention, by Otis T. Mason.....	461
The Abbott Collection from the Andaman Islands, by Lieut. W. E. Safford, U. S. N.....	475
The Development of Illumination, by Walter Hough.....	493
Order of Development of the Primal Shaping Arts, by W. H. Holmes.....	501
Boomerangs, by Gilbert T. Walker.....	515
The Possible Improvement of the Human Breed under the Existing Conditions of Law and Sentiment, by Francis Galton.....	523
The Fire Walk Ceremony in Tahiti, by S. P. Langley.....	539
The Laws of Nature, by S. P. Langley.....	545
The Children's Room in the Smithsonian Institution, by Albert Bigelow Paine.	553
Salt and its Physiological Uses, by A. Dastre.....	561
Santos-Dumont Circling the Eiffel Tower in an Air Ship, by Eugene P. Lyle, jr.	575
Automobile Races, by Henri Fournier and others.....	593
The Erection of the Gokteik Bridge, by Day Allen Willey.....	611
The Great Alpine Tunnels, by Francis Fox.....	617
The Mutation Theory of Professor De Vries, by Charles A. White.....	631
The Dinosaurs, or Terrible Lizards, by F. A. Lucas.....	641
The Greatest Flying Creature, by S. P. Langley, introducing a paper by F. A. Lucas on the Great Pterodaetyl Ornithostoma.....	649
The Okapi; the newly discovered beast living in Central Africa, by Sir Harry H. Johnston.....	661
Observations on Termites, or White Ants, by G. D. Haviland.....	667
The Wanderings of the Water Buffalo.....	679
On the Preservation of the Marine Animals of the Northwest Coast, by William H. Dall.....	683
Some Private Zoos, by F. G. Aflalo.....	689
The National Zoo at Washington, a study of its animals in relation to their natural environment, by Ernest Thompson Seton.....	697
The Submarine Boat, by Rear-Admiral George W. Melville.....	717
Commemoration of Prof. Henry A. Rowland, by T. C. Mendenhall.....	739

## LIST OF PLATES.

	Page.		Page.
<b>SECRETARY'S REPORT:</b>		<b>HISTORY OF CHRONOPHOTOGRAPHY</b>	
Plate I.....	14	(Marey):	
Plate II.....	31	Plate I.....	320
Plate III.....	40	Plate II.....	329
Plate IV.....	49	Plate III.....	330
Plate V.....	66	Plate IV.....	331
Plate VI.....	70	Plate V.....	332
Plate VII.....	108	Plate VI.....	333
Plate VIII.....	109	Plate VII.....	334
Plate IX.....	110	Plate VIII.....	335
Plate X, XI, XII.....	124	Plate IX.....	340
Plate XIII.....	125	<b>NATIONAL PHYSICAL LABORATORY</b>	
<b>THE SMITHSONIAN INSTITUTION:</b>		(Glazebrook):	
Plate I.....	145	Plate I.....	344
Plate II.....	146	Plate II.....	351
Plate III.....	147	<b>EMIGRANT DIAMONDS (Hobbs):</b>	
Plate IV.....	148	Plate I.....	360
Plate V.....	149	Plate II.....	362
Plate VI.....	150	Plate III.....	364
<b>PRINCIPAL EVENTS IN ASTRONOMY</b>		<b>BOGOSLOF VOLCANOES (Merriam):</b>	
(Abbot):		Plate I.....	368
Plate I.....	154	Plate II.....	370
Plate II (Heliotype).....	156	Plate III.....	372
Plate III.....	156	<b>VOYAGE OF THE BELGICA (Arctowski):</b>	
Plate IV (Heliotype).....	158	Plate I.....	378
Plate V.....	162	Plate II.....	380
Plate VI.....	168	Plate III.....	382
<b>USE OF KITES AT SEA (Rotch):</b>		Plate IV.....	383
Plate I.....	246	Plate V.....	384
Plate II.....	248	Plate VI.....	386
<b>UTILIZING SUN'S ENERGY (Thurston):</b>		Plate VII.....	388
Plate I.....	268	<b>FOREST DESTRUCTION (Pinchot):</b>	
<b>WIRELESS TELEGRAPHY (Marconi):</b>		Plate I.....	401
Plate I.....	287	Plate II.....	402
<b>TRANS-ATLANTIC TELEPHONING</b>		Plate III.....	403
(Anthony):		Plate IV.....	404
Plate I.....	304	<b>IRRIGATION (Newell):</b>	
Plate II.....	305	Plate I.....	410
<b>THE TELEPHONOGRAPH (Hammer):</b>		Plate II.....	412
Plate I.....	308	Plate III.....	414
Plate II (colored).....	312	Plate IV.....	417
<b>COLOR PHOTOGRAPHY (Herschel):</b>		Plate V.....	418
Plate I (colored).....	314	Plate VI.....	420
Plate II (colored).....	315	Plate VII.....	422
Plate III (colored).....	316		

PALACE OF MINOS (Evaus):	Page.	AUTOMOBILE RACES—Continued.	Page.
Plate I.....	430	Plate VI.....	609
Plates II-V.....	431	GREAT ALPINE TUNNELS (Fox):	
Plate VI.....	432	Plate I.....	622
Plate VII.....	433	Plate II.....	624
Plate VIII.....	434	Plate III.....	626
TRAPS OF AMERICAN INDIANS (Mason):		Plate IV.....	628
Plate I.....	474	DINOSAURS (Lucas):	
ABBOTT COLLECTION FROM ANDAMAN ISLANDS (Safford):		Plate I.....	644
Plate I.....	488	Plate II.....	645
Plate II.....	490	Plate III.....	646
Plates III-VI.....	492	Plate IV.....	647
DEVELOPMENT OF ILLUMINATION (Hough):		GREATEST FLYING CREATURE (Langley):	
Plates I, II.....	500	Plate I.....	649
FIRE WALK IN TAHITI (Langley):		Plate II.....	650
Plate I.....	540	Plates III, IV (to face one another).....	652
Plate II.....	541	Plate V.....	654
Plate III.....	542	Plate VI.....	657
CHILDREN'S ROOM (Paine):		Plate VII.....	658
Plate I (colored).....	553	THE OKAPI (Johnston):	
Plates II, III (colored).....	554	Plate I (colored).....	661
Plate IV (colored).....	555	Plate II.....	662
Plate V (colored).....	556	Plate III.....	664
Plate VI (colored).....	557	TERMITES, OR WHITE ANTS (Haviland):	
Plates VII, VIII.....	558	Plates I-IV.....	678
Plate IX.....	559	WANDERINGS OF WATER BUFFALO:	
Plates X, XI (colored).....	560	Plate I.....	682
Plates XII-XX.....	560	SOME PRIVATE ZOOS (Aflalo):	
CIRCLING EIFFEL TOWER IN AIRSHIP (Lyle):		Plates I-II.....	690
Plate I.....	575	Plates III-IV.....	692
Plate II.....	576	Plates V-VI.....	694
Plate III.....	577	Plate VII.....	696
Plate IV.....	578	NATIONAL ZOOLOGICAL PARK (Seton):	
Plate V.....	579	Plate I.....	704
Plate VI.....	580	Plate II.....	705
Plate VII.....	582	Plate III.....	706
Plate VIII.....	584	Plate IV.....	710
Plate IX.....	586	Plate V.....	712
Plate X.....	588	Plates VI-IX.....	714
AUTOMOBILE RACES:		Plates X-XIII.....	716
Plate I.....	594	SUBMARINE BOAT (Melville):	
Plate II.....	596	Plate I.....	730
Plate III.....	606	Plate II.....	732
Plate IV.....	607	ROWLAND MEMORIAL (Mendenhall):	
Plate V.....	608	Plate I.....	739





## THE SMITHSONIAN INSTITUTION.

---

### MEMBERS EX OFFICIO OF THE "ESTABLISHMENT."

---

WILLIAM MCKINLEY, President of the United States.  
THEODORE ROOSEVELT, Vice-President of the United States.  
MELVILLE W. FULLER, Chief Justice of the United States.  
JOHN HAY, Secretary of State.  
LYMAN J. GAGE, Secretary of the Treasury.  
ELIHU ROOT, Secretary of War.  
PHILANDER C. KNOX, Attorney-General.  
CHARLES EMORY SMITH, Postmaster-General.  
JOHN D. LONG, Secretary of the Navy.  
E. A. HITCHCOCK, Secretary of the Interior.  
JAMES WILSON, Secretary of Agriculture.

---

### REGENTS OF THE INSTITUTION.

(List given on the following page.)

---

### OFFICERS OF THE INSTITUTION.

SAMUEL P. LANGLEY, *Secretary,*

*Director of the Institution and of the U. S. National Museum.*

RICHARD RATHBUN, *Assistant Secretary.*

---

## REGENTS OF THE SMITHSONIAN INSTITUTION.

---

By the organizing act approved August 10, 1846 (Revised Statutes, Title LXXIII, section 5580), "The business of the Institution shall be conducted at the city of Washington by a Board of Regents, named the Regents of the Smithsonian Institution, to be composed of the Vice-President, the Chief Justice of the United States, three members of the Senate, and three members of the House of Representatives, together with six other persons, other than members of Congress, two of whom shall be resident in the city of Washington and the other four shall be inhabitants of some State, but no two of the same State.

---

### *REGENTS FOR THE YEAR ENDING JUNE 30, 1901.*

The Chief Justice of the United States:

MELVILLE W. FULLER, elected Chancellor and President of the Board, January 9, 1889.

The Vice-President of the United States:

THEODORE ROOSEVELT.

United States Senators:

	Term expires.
SHELBY M. CULLOM* (appointed Mar. 24, 1885, Mar. 28, 1889, Dec. 18, 1895, and Mar. 7, 1901).....	Mar. 3, 1907
ORVILLE H. PLATT (appointed Jan. 18, 1899).....	Mar. 3, 1903
WILLIAM LINDSAY (appointed Mar. 3, 1899).....	Mar. 3, 1901
FRANCIS M. COCKRELL (appointed Mar. 7, 1901).....	Mar. 3, 1905

Members of the House of Representatives:

ROBERT R. HITT (appointed Aug. 11, 1893, Jan. 4, 1894, Dec. 20, 1895, Dec. 22, 1897, and Jan. 4, 1900).....	Dec. 25, 1901
ROBERT ADAMS, JR. (appointed Dec. 20, 1895, Dec. 22, 1897, and Jan. 4, 1900).....	Dec. 25, 1901
HUGH A. DINSMORE (appointed Jan. 4, 1900).....	Dec. 25, 1901

Citizens of a State:

JAMES B. ANGELL, of Michigan (appointed Jan. 19, 1887, Jan. 9, 1893, and Jan. 24, 1899).....	Jan. 24, 1905
ANDREW D. WHITE, of New York (appointed Feb. 15, 1888, Mar. 19, 1894, and June 2, 1900).....	June 2, 1906
RICHARD OLNEY (appointed Jan 24, 1900).....	Jan. 24, 1906

Citizens of Washington:

JOHN B. HENDERSON (appointed Jan. 26, 1892, and Jan. 24, 1898).....	Jan. 24, 1904
WILLIAM L. WILSON (appointed Jan. 14, 1896; died Oct. 17, 1900).	
ALEXANDER GRAHAM BELL (appointed Jan. 24, 1898).....	Jan. 24, 1904
GEORGE GRAY (appointed Jan. 14, 1901).....	Jan. 14, 1907

---

### *Executive Committee of the Board of Regents.*

J. B. HENDERSON, *Chairman.*

ALEXANDER GRAHAM BELL.  
ROBERT R. HITT.

## PROCEEDINGS OF THE BOARD OF REGENTS AT THE ANNUAL MEETING HELD JANUARY 23, 1901.

---

In accordance with a resolution of the Board of Regents, adopted January 8, 1890, by which its annual meeting occurs on the fourth Wednesday of each year, the Board met to-day at 10 o'clock a. m.

Present: The Chief Justice, the Hon. M. W. Fuller (Chancellor), in the chair; the Hon. O. H. Platt; the Hon. William Lindsay; the Hon. R. R. Hitt; the Hon. Robert Adams, Jr.; the Hon. Hugh A. Dinsmore; Dr. J. B. Angell; Dr. A. Graham Bell; the Hon. Richard Olney; the Hon. George Gray; and the Secretary, Mr. S. P. Langley.

Excuses for nonattendance were read from the Hon. William P. Frye and the Hon. J. B. Henderson, on account of illness.

At the suggestion of the Chancellor the minutes of the last annual meeting were read in abstract, and there being no objection, they were declared approved.

The Secretary announced the death on October 17, 1900, of Dr. William Lyne Wilson, and stated that Mr. Henderson had very much desired to present some personal remarks on the occasion, but that his illness had prevented him from attending the meeting.

Mr. Bell then offered a series of resolutions, which will be found under the heading "Necrology," on page 51 of this report.

The resolutions were adopted by a rising vote. Mr. Hitt then stated that he had received a request from Mr. Henderson to ask the Board's permission to file later a memorial to be spread upon the minutes. On motion, the permission was granted.

The Secretary read acknowledgments from Mrs. Margaret A. Johnston and Mrs. Jennie T. Hobart of the resolutions adopted by the Board on account of the death of Dr. William Preston Johnston and of Vice-President Hobart.

### APPOINTMENT OF REGENTS.

At the last meeting the Secretary announced that a resolution appointing the Hon. Richard Olney a regent to succeed the late Dr. William Preston Johnston had passed Congress, but was still in the hands of the President. The President's approval was given on the day of the meeting, January 24, but it was then, of course, too late to notify Mr. Olney and secure his attendance.

The term of Dr. Andrew D. White having expired, he was reappointed to succeed himself by a joint resolution of Congress approved June 2, 1900.

The vacancy in the Board, caused by the death of Dr. William L. Wilson, has been filled by the appointment of the Hon. George Gray, through a joint resolution approved January 14, 1901.

The Secretary read a letter of acceptance from Dr. Andrew D. White, at present United States ambassador to Germany.

The Secretary presented his annual report to June 30, 1900, calling the attention of the Regents to the fact that it contained an account of every important part of the affairs of the Smithsonian Institution during the past year prepared by himself, but supplemented by full reports from the gentlemen in charge of the various bureaus. He would particularly call their attention, among numerous matters in the report, to the subject of the Exchanges. He then detailed the facts of the applications of the Institution through our ambassadors at London, Paris, and Berlin, in the interests of the Government.

The Secretary spoke about the Zoological Park and the desirability that the Government would place in that city of refuge for the vanishing animal races of the North American continent some specimens of the giant animals of Alaska, which were now going the way that the buffalo had gone. He then asked the attention of the Regents to a subject of minor importance, but of some interest, alluded to in the report under the title of the Children's Room.

On motion, the report was accepted.

Mr. Hitt here said that he desired to bring before the Board the knowledge of certain proceedings which had taken place at the University of Cambridge in England when the Secretary had received the honorary degree of doctor of science. This had been conferred in connection with an oration in Latin delivered by the public orator, and which Mr. Henderson, whom they knew to be a scholar who loved the tasks of scholarship, had translated into such English as Horace would have used if he had to speak in that tongue. Mr. Henderson had sent him a copy of this, and he now presented it to the Board with a request that it be placed upon the minutes. Mr. Hitt then read the following translation:

From across the Atlantic there has very recently been borne to us a man distinguished in the world of science—one who but lately has published a most interesting and useful work on astronomy. In the city which is the capital of the greatest transmarine republic many important duties are committed to his care: First, the supervision of a great museum abundantly filled with objects of natural history; next, the administration of an institution the most celebrated for the increase and diffusion of knowledge among men; and, lastly, the control of an observatory with instruments designed for the purpose of dissecting and analyzing the light of the stars. It is said that below the red rays of the spectrum there are other rays, undetected by the sharpest vision, but which, through the genius of this man, aided by an instrument discovered by him and named a "bolometer," have been gradually developed and made plainly visible.

No one will wonder that a man thus fond of communing with the stars should also be moved by a great desire to fly from earth, so great indeed that, as if by wings attached, he has actually been enabled to imitate the flight of birds for a distance exceeding 3,000 feet. Not fearing, perhaps, the fate of Icarus, he may yet be able himself to make good the vision of Horace, the poet:

“On strong but unaccustomed wings I fly,  
And soar as bird and man through liquid sky.”

Perhaps, impatient of this world's affairs and longing for celestial ones, he may well be emboldened to fly from earth and take his place among the stars.

I present to you Samuel Pierpont Langley.

On motion, the Latin address of the public orator and the translation of Mr. Henderson were directed to be placed upon the records.

CAMBRIDGE, *October 11, 1900.*

The following is the speech delivered by the public orator in presenting Mr. Samuel Pierpont Langley for the degree of doctor in science *honoris causa*:

Trans aequor Atlanticum ad nos nuper advectus est vir scientiarum in provincia insignis, qui etiam de astronomia recentiore librum pulcherrimum conscripsit. In urbe quod reipublicae maximae transmarinae caput est, viri huiusce curae multa mandata sunt; primum museum maximum rerum naturae spoliis quam plurimis ornatum; deinde institutum celeberrimum scientiae et augendae et divulgandae destinatum; denique arx et specula quaedam stellarum lumini in partes suas distribuendo dedicata. Luminis in spectro, ut aiunt infra radios rubros radii alii qui oculorum aciem prorsus effugiunt, viri huiusce ingenio, instrumenti novi auxilio quod *βολόμετρον* nominavit, paulatim proditi et patefacti sunt. Nemo mirabitur virum stellarum observandarum amore tanto affectum, etiam e terra volandi desiderio ingenti esse commotum, adeo ut, quasi alis novis adhibitis, plus quam trium milium pedum per spatium, etiam avium volatum aemulari potuerit. Fortasse aliquando, Icarum sortem non veritus, etiam Horati praesagia illa sibi ipsi vendicabit.

“non usitata nec tenui ferar  
penna biformis per liquidum aethera.”

Fortasse rerum terrestrium impatiens, rerum caelestium avidus, ausus erit e terris “volare sideris in numerum, atque alto succedere caelo.”

Duco ad vos Samuelem Pierpont Langley.

In the absence of Mr. Henderson Mr. Bell presented the report of the Executive Committee to June 30, 1900, which, on motion, was adopted.

The Chancellor stated that a vacancy existed in the Executive Committee, caused by the death of Dr. Wilson.

Senator Platt then offered the following resolution:

*Resolved*, That the vacancy in the Executive Committee caused by the death of Dr. William Lyne Wilson be filled by the election of the Hon. R. R. Hitt.

On motion the resolution was adopted.

Mr. Bell then offered the following customary resolution relative to income and expenditure:

*Resolved*, That the income of the Institution for the fiscal year ending June 30, 1902, be appropriated for the service of the Institution, to be expended by the Secretary, with the advice of the Executive Committee, with full discretion on the part of the Secretary as to items.

On motion the resolution was adopted.

## REPORT OF THE PERMANENT COMMITTEE.

In the absence of Mr. Henderson, Chairman of the Permanent Committee, the Secretary made the following statement:

*The Hodgkins Fund.*—The Hodgkins Fund now amounted to about \$250,000, \$208,000 of which was deposited in the general funds, the remainder being held in first-class bonds. About \$10,000 more was held in New York to meet possible litigation, but the indications were that the Institution would receive this also. There were also two houses of small value which would probably net the fund about \$1,600.

*The Avery Fund.*—This, as well as other matters of the kind, were being looked after by the attorney of the Institution, Mr. F. W. Hackett, who reports satisfactory progress. As to the value of this Avery estate, the Secretary had requested an approximate valuation from Mr. Fox, the real-estate agent who had charge of the property, and who stated the same at about \$26,000. Mr. Fox had written that if the United States Supreme Court Building were placed directly north of the Congressional Library the value of part of the property would be greatly increased. This property, most of which was idle, was yielding an income of something like \$500 a year.

*The Andrews Bequest.*—This matter had been laid before the Board at its last meeting, and Mr. Hackett has reported that the estate would probably amount to something like a million of dollars. No active steps as yet had been taken in Ohio looking to an application of this money for the establishment of an institution for the free education of girls. It was by no means certain that the elaborate system formulated in the will was capable of being put into successful operation. The Secretary here quoted from Mr. Hackett's report:

It may be needful before long to institute a friendly suit in New York to ascertain under the laws whether the legacy be a valid one to the Ohio corporation, or rather to the corporation that the will says shall be created in Ohio. I shall make this the subject of a separate letter to you in a few days. Meanwhile, as a report to the Regents of the progress making in this business, I will say that I am giving more or less attention from time to time to the will and its legal aspects, and also am in touch with the counsel for the executor.

*The Sprague Bequest.*—The Secretary now stated that he had the agreeable duty of bringing before the Regents the fact of another legacy to the Institution by Mr. Joseph White Sprague, whose last place of residence was in the city of Louisville, Ky., but who died in Italy in June, 1900. Under the provisions of his will, which had been offered for probate, certain personal effects were bequeathed to relatives, and all the remainder of his estate, both real and personal, to his nephew, Seth Sprague Terry, in trust to convert the personalty into money and distribute 85 per cent of the profits of the entire estate among certain devisees named in the will, and their relatives, until twenty years after the death of the last of said devisees, when the trust

expired by limitation and all assets in the hands of the trustee were to be conveyed to the United States of America to be held as a portion of the funds of the Smithsonian Institution, and to be known as the "Sprague Fund." One-half of the income of this fund was to be added to the principal each year; the other half to be expended under the direction of the Institution, in such manner as would "best promote the advancement of the physical sciences" by the giving of free lectures, providing laboratory facilities for original scientific research, publishing the results of such researches, or by awarding medals or other rewards for meritorious discoveries. The half of the gross income authorized to be expended annually in this manner was to be cumulative, and any portion not expended during one year might be expended during any subsequent year.

The Secretary continued that it had not yet been possible to obtain an inventory of the value of the estate, but he might mention that in a newspaper estimate it was represented at \$200,000.

#### TWO-HUNDREDTH ANNIVERSARY OF THE ROYAL PRUSSIAN ACADEMY OF SCIENCES.

The Royal Prussian Academy of Sciences having invited the Smithsonian Institution to participate in the celebration of the two-hundredth anniversary of its foundation, on the 19th and 20th of March, 1900, the Hon. Andrew D. White, United States Ambassador at Berlin, and member of the Board of Regents, was requested to represent the Institution on this noteworthy occasion. A suitably engrossed address, conveying the congratulations of the Institution, and transmitted through the Department of State to Dr. White, was presented by him to the Prussian Academy and cordially acknowledged in terms of which the following is a summary:

The Royal Prussian Academy expresses the most sincere thanks for the interest the Smithsonian Institution has taken in the celebration of its two-hundredth anniversary. The expression of this friendly interest has added greatly to the success and pleasure of these commemorative exercises throughout their entire course.

For a lasting memorial of this anniversary the Academy sends a description of the festival, which it begs the Institution to place in its archives. This record will derive its chief value from the addresses and memorials attached to it.

An interesting letter from Dr. White was laid before the Regents. It described the exercises as having been of an exceptional interest. They took place in the Royal Palace, where the King and Emperor received the entire body of guests in state, surrounded by the high functionaries of the Kingdom bearing the Royal insignia, while the monarch from the throne delivered a very interesting address of welcome. Later there were entertainments in honor of the delegates not only by the King, but by the Chancellor of the Empire and others. On the second day occurred a general reception in the great hall of

the Prussian legislature, which was also very impressive. The whole occasion was most interesting and everything was most admirably done.

The Secretary added that Dr. White had further said in conversation that in all his experience as a minister to European courts he had never seen so imposing a display of ceremonial magnificence.

#### MR. BELL'S RESOLUTION.

Under the head of unfinished business the Chancellor called up the resolution offered at the last meeting by Mr. Bell.

Mr. Bell said that he thought the Institution could not afford to remain silent on the subject of the great questions aroused by the National University project, and that some expression of the good will of the Institution at least might well be given. He, therefore, desired to withdraw the resolution offered last year and to substitute for it the following, which was satisfactory to the Executive Committee:

In order to facilitate the utilization of the Government Departments for the purposes of research—in extension of the policy enunciated by Congress in the joint resolution approved April 12, 1892:

*Resolved*, That it is the sense of the Board that it is desirable that Congress extend this resolution so as to afford facilities for study to all properly qualified students or graduates of universities, other than those mentioned in the resolution, and provide for the appointment of an officer whose duty it shall be to ascertain and make known what facilities for research exist in the Government Departments, and arrange with the heads of the Departments, and with the officers in charge of Government collections, on terms satisfactory to them, rules and regulations under which suitably qualified persons may have access to these collections for the purpose of research with due regard to the needs and requirements of the work of the Government; and that it shall also be his duty to direct, in a manner satisfactory to the heads of such Departments and officers in charge, the researches of such persons into lines which will promote the interests of the Government and the development of the natural resources, agriculture, manufactures, and commerce of the country, and (generally) promote the progress of science and the useful arts, and the increase and diffusion of knowledge among men.

After some discussion by the Regents, on motion the resolution was adopted.

#### REMOVAL OF SMITHSON'S REMAINS.

The Secretary stated that he had received the following letter:

7 VIA GARIBALDI,  
Genoa, 24 November, 1900.

SAMUEL PIERPONT LANGLEY, Esq., LL. D., D. C. L.,

*Smithsonian Institution, Washington.*

DEAR SIR: The Committee of the British Burial Ground of Genoa (of which, as you are aware, Her Majesty's consul is chairman), fully realizing how keenly you are interested in all that concerns the resting place of the respected Founder of your Institution, has deputed me to write to you and lay before you the present position of our cemetery.

It will lie in your recollection that when I accompanied you some years ago up to the heights of San Benigno you were struck by the enormous quarry which was



slowly but surely eating its way toward us from the sea through the rocky side of the hill on which we stand, and the excavation has lately come so close to us that the intervention of the consul became necessary to arrest further advance, on the plea that our property would be endangered if the quarrying were carried on.

Actual blasting has in fact been put an end to for the present, and the cemetery (although the boundary wall is now on the very edge of the excavation) remains untouched, but the local authorities who are the owners of the quarry have given us to understand that they need more stone for their harbor works and are therefore anxious to see our graves transferred from the position they now occupy, for which purpose they would give us a suitable piece of ground in another part of the town and would also undertake the due and fitting transport of the remains. Should our answer be in the negative, it is intimated to us that in five years' time, in 1905, the term for applying the law for public utility (twenty years after the date of the last burial) will have been reached, and we shall then have to give up of necessity what we are now asked to yield as a concession.

Under the circumstances the committee have decided that it is their best policy, in the interest of all concerned, to begin to negotiate at once for the transfer on a decorous footing of the British Cemetery and all its tombs, and although some considerable time may elapse before this transfer is accomplished, yet it is evident that the time has now come for us to ask you to prepare your decision as to what is to be done with regard to the James Smithson remains. Are they to be laid with all possible care and reverence in new ground here, or are they to be conveyed to the United States?

Awaiting the pleasure of your reply, I beg to remain,  
Very faithfully, yours,

E. A. LE MESURIER.

The Secretary said that the cemetery referred to was not the celebrated Campo Santo of Genoa, but a very small one in the care of the British consul and the English church, situated in an elevated and isolated spot, and that no interment had occurred there for many years. The Regents had formerly authorized the placing of a bronze tablet on Smithson's tomb, which had been done.

The Secretary here exhibited photographs of the tomb, showing the bronze tablet in position. Recently word had been received that the bronze tablet had been stolen, but orders had been given to replace it by a marble one.

After some discussion, in which the desirability of bringing the remains to this country was adversely considered, the following resolution, offered by Mr. Adams, was adopted:

*Resolved*, In view of the proposed abolition of the English cemetery at Genoa, which contains the remains of James Smithson, that the Secretary be requested to arrange either with the English church or with the authorities of the national burying ground at Genoa for the reinterment of Smithson's remains and the transfer of the original monument.

#### SECRETARY'S STATEMENT.

*Experiments in Aerodromics—Eclipse expedition.*—The Secretary stated that in view of the lateness of the hour he would pass over some of the matters about which he had intended to speak, among

others the continuation of his experiments in aerodromics, which, with the consent of the Regents, he was making for the War Department, and of the results of the eclipse expedition of May, 1900, further than to say in regard to the latter that they were of rather more than ordinary importance; that they had left one or two interesting but unsettled questions, particularly that as to the possibilities of the observation of Intramercurial planets, which had determined him to send out a small expedition to Sumatra to settle these questions on the occasion of the exceptionally important eclipse of the sun in May of the present year.

*Ur of the Chaldees.*—In October, 1899, Dr. Edgar James Banks, of Cambridge, Mass., had written to inquire whether the Smithsonian Institution would accept a collection of Babylonian antiquities, if such could be procured. He stated that he hoped to be able to secure valuable material by excavating at the town of Mugheir, situated on the Euphrates River, which, according to tradition, is the site of Ur of the Chaldees, from which Abraham came. Being satisfied after investigation of the standing of Dr. Banks, and one of the Regents of the Institution being among the vice-presidents of his association, the Secretary accepted his proposition, which committed the Institution to nothing but the receipt of the finds. One of the employees of the National Museum would be of the party and would collect ethnological and natural history specimens. Any prediction with regard to the expedition must be premature, but it might be said that this site, if correctly chosen, was one of the most importance for students of the Bible and of ancient history yet to be examined, and that there was reasonable expectation that the Institution would reap a reward.

*Smithsonian deposit in the Library of Congress.*—The Smithsonian deposit was created originally by a relatively very large expenditure from the proper funds of this Institution, nearly half whose income went in this direction for several years. The money, the Secretary was told, was spent at a time when such things were cheaper than now, and well spent, for a varied collection of works, partly but not exclusively scientific; but during the last twenty-five years the immensely increasing demand upon the small fund of the Institution had caused it to add little to its library by direct purchase, though this had continued to increase largely through the exchange system, chiefly in the direction of scientific periodicals.

The Regents would remember the Secretary's explaining to them two years ago that by an informal arrangement made between Professor Henry and the Library Committee, in 1866, the Library of Congress was not required to keep the Smithsonian books together, but merely to see that they had a proper mark indicating that they belonged to the Institution.

These books, which Congress had assumed the care of, had been

lying, it was too well known, in compulsory neglect and disorder, owing to the lack of room in the old quarters in the Capitol, but since their transfer to the new Library building they had been rearranged and much had been done toward bringing into order this valuable Smithsonian deposit, which was in some respects the finest collection of scientific periodicals and reports of learned societies in the world.

Congress had last year made an increase in the working force of the Library, and had provided for three persons, one custodian and two messengers, to look after the Smithsonian deposit.

The books had an entire "stack," which would hold 175,000 volumes, and was called the "East stack," assigned to them, and besides this one of the great halls, which was to be used for the books in more immediate demand, and also as a reading room.

An appropriation of \$30,000 was made, to be expended under the Librarian of Congress, for fitting up this room, and while even this large room would not be sufficient to bring together all the Smithsonian books, it would bring together most of the transactions of the learned societies and scientific periodicals, which were among the most valuable portions of the Library.

He desired to engage the interest of the Regents in procuring for the expenditure, either through their Secretary or the Librarian of Congress, a sum of in all not less than \$50,000 for the joint purpose of supplying the defects in the library due to its neglect for the past twenty years, and to fill in the important sets of periodicals which can not be secured by exchange. This money could not be spent rapidly, since many of the books could now be got only after long search, and he presumed that it would take several years to supply the actual losses.

*International Catalogue of Scientific Literature.*—The Secretary said that he had not time to enter upon this subject at length, but he would remind the Regents that the Smithsonian Institution had long ago, under Professor Henry, proposed the scheme of a general catalogue of scientific literature to the Royal Society of London for their joint consideration.

The Royal Society, within the last two or three years, had resumed the project which had now grown to be a very large one. It had recently called for and obtained the official aid of the principal governments of the world, and England, France, Germany, and other leading European nations had made large appropriations to this great work. It had been hoped that our own National Government would take its share in this enterprise, but the Secretary regretted to say that it had not done so, although the Department of State had earnestly recommended it.

The Smithsonian Institution, which had been the original suggester of this great plan, desired to be still associated with it in the measure

of its ability, and had caused a circular to be sent during the past summer to the libraries, universities, and scientific establishments of the United States, and solicited support for this international project in the name of the Institution. He was gratified to be able to say that the response had been most hearty, and that 66 sets of this costly publication had been subscribed for here, which was a much more considerable aid than had been rendered by the peoples of any other nations apart from the national subscriptions.

The Secretary hoped that our Government would yet do something for this. He was entirely willing that the work should be continued provisionally under the Institution as suggested by the Secretary of State, but while he believed that it was the wish of all American scientific men that the work should be done here, he did not desire to have the Institution appear as a solicitor of Congress for the necessary appropriation while so many things of more immediate urgency to its own interests were ungranted. He would temporarily continue a certain amount of the cataloguing as aid on the part of the Institution, which was, in this respect, taking the duties of what was called in Europe a "regional bureau."

#### SPECIAL STATEMENT SMITHSONIAN FUND AND MUSEUM.

Continuing, the Secretary said:

The Regents have received my printed official report, and as I hope that they have read it I shall not dwell on its contents, but will speak now of certain subjects of special concern. The real matter, to the Secretary at least, always lies in the actual presence of the Regents, and his ability to bring to them his difficulties directly and to obtain their guidance. I say this now not with reference to anything that presses for present action, but to be sure that I know their wishes in the shaping of a policy which causes me frequent official anxiety. I do not mean with reference to the parent Institution, for there never was a time when its small means were productive of more satisfactory results, or when it was better known throughout the whole world than it is to-day, but I immediately speak of the bureaus which the Government has put in its charge, and for the moment particularly of the Museum.

The Regents will remember that on the resignation of Acting Assistant Secretary Charles D. Walcott, I asked them to authorize the removal of the restrictions on the appointment of the Assistant Secretary, Mr. Richard Rathbun, so that he could be assigned to other duties, especially that of Assistant Secretary in charge of the Museum, with the aid of three Head Curators, and that I spoke of this as an experiment upon which I would report later. It having been found impracticable that Mr. Rathbun should give his chief attention to the parent Institution and satisfactorily administer the Museum also, I have recently made arrangements by which he could give his principal attention to the latter, and in this form, after two years' trial, I can report favorably upon the plan.

I think it is working well for two reasons. The first is personal to Mr. Rathbun, who has a fund of tact and patience, united with professional sympathy, which few men possess in a greater degree.

The other reason why the present plan is successful lies, I think, in the nature of the Regents' own control, and here I want to revert to the fact that the Museum as it exists has grown from the parent stem of the Smithsonian Institution, and grown so

fast that the child is tending to become larger than the parent. There are signs that the Committee on Appropriations is at last coming to see the inevitable necessity of enlarging the Museum buildings, and with this enlargement will come an increased expenditure and a new era of responsibility for its management. With a million dollars or more of annual expenditure the Museum will be more like other great bureaus of the Government. I can say that I think the present system of administration through the Regents is not only free from every suspicion of political influence, but through the method of election and appointment of its governing body and officers, has an assurance of permanence and of unselfish administration which no other method known to our Government affords.

The Secretary is, under the fundamental law, the Keeper of the Museum. Although a scientific man himself, he is not disposed in this connection to favor one branch of science as against another. (At least, if I may speak for myself, I think I am not.) While retaining in his own hands so much of the authority which the Regents and the law have imposed on him as is necessary for a proper coordination of all the interests of the Institution, and while personally passing upon all matters of policy, relations with important foreign and domestic establishments and all unusual or extraordinary expenditures, he has always managed the details of the Museum administration through an Assistant Secretary. Such men as Baird, Goode, Walcott, and Rathbun have successively filled this office, and in every instance not only deserved the confidence of the Regents and the Secretary, but have gained the confidence of the scientific community.

I think, then, that the present plan of administration is working well, but I desire the Regents to bear in mind that an extension of the work to be done is likely to be later demanded by scientific public opinion; that the time has nearly come when Congress will look favorably upon it, and that when the time for this extension actually does come I hope they will feel that their own just and impartial rule is the best that the Museum is likely to have in the future, as it is that which has built it up in the past, guaranteeing as it does deliberation and fairness in the selection of the Museum officers and a stability in its policy.

There is something to be said with regard to each of the other bureaus, but the Regents will find this set forth in the Report, particularly with regard to the Secretary's personal efforts made last year to extend the field of the Bureau of Exchanges. I wish, however, before concluding these statements to the Regents, to revert to a subject on which I have already asked their advice and which is of fundamental importance.

The Chancellor remarked on a previous occasion that the time seemed to be coming when the Institution would be more and more in the way of receiving gifts, like the Hodgkins gift. I hope and believe that this opinion will be justified, and I have had the pleasure of bringing some evidences of it before the Regents this morning, but I ask them to bear in mind, with regard to the Smithsonian Institution, which has been called an anomaly in our Government, that its best feature, and that which makes it a happy anomaly, is that while the whole is in the care of the State, there is an independent fund under the Regents' control. Now I beg them to consider that this all-important feature of independence is every year lessening in its character, owing to the decreasing relative importance of the fund by reason of the changing value of money, and the enormously increased wealth of the country around it. Thus in 1850 the Smithsonian Institution's fund was over \$600,000. This was at the time a noble foundation, but how relatively small it is to-day can be seen from the greatly increased funds now in the hands of other institutions of learning. I have written to the presidents of a number of the principal American universities in existence in 1850 and asked the extent of their endowment at that time.

Fifty years ago, the President of Yale University informs me, the funds of that great institution were about \$300,000. At that time the Smithsonian Institution

fund was over \$600,000, or more than twice that of Yale. Now President Hadley tells me that the invested funds of Yale are about five and one-quarter million dollars. The Smithsonian fund is nearly what it was; that is, except for the Hodgkins legacy; it is about one-sixth that of Yale; which is saying that the Smithsonian fund has relatively decreased in the proportion of 12 to 1.

Not to found this comparison on the solitary case of Yale, I have inquired in this way of the Presidents of seven of our leading colleges and universities, and I have answers from five: Harvard, Yale, Columbia, Princeton, and the University of Pennsylvania.

Columbia reports an income of \$11,000 in 1850, but no endowment. Harvard is the only college or university which fifty years ago had a fund as large as that of the Smithsonian Institution. The average fund of Harvard, Yale, Columbia, and Pennsylvania in 1850 I find to be about \$450,000. The average fund of each of those same four institutions to-day, as their presidents and treasurers report to me, is about \$8,600,000 (an average increase of nearly 2,000 per cent).

If some of the newer universities, as Stanford, and Chicago, whose funds are believed to be collectively \$25,000,000, are brought into this estimate, the result is that while at the time of its organization the Smithsonian Institution, with one exception, was very much wealthier than any university or college in the United States, to-day it has about one-twelfth of the average property of those to which it was formerly superior.

If there is any object that lies near my heart, it is that the Institution should become so known throughout the country that gifts and devises which would increase that part of its funds under the absolute control of the Regents should be stimulated and increased. I am convinced that it is but necessary that the whole of the American people who have money to devise or give shall only know what the Institution has done in the past and what it guarantees under the rule of the Regents in the expenditure of funds in the future, to bring in such gifts in increasing number. I will do anything I can personally to aid this, and while it is not becoming that the Institution should wear the appearance of soliciting anything of the kind, I should be very glad for any counsel from the Regents as to the means of aiding it.

The Regents informally discussed the matters suggested by the Secretary, but, time preventing, took no action; and, on motion, the Board adjourned.

# REPORT OF THE EXECUTIVE COMMITTEE OF THE BOARD OF REGENTS OF THE SMITHSONIAN INSTI- TUTION

FOR THE YEAR ENDING JUNE 30, 1901.

---

*To the Board of Regents of the Smithsonian Institution:*

Your Executive Committee respectfully submits the following report in relation to the funds of the Institution, the appropriations by Congress, and the receipts and expenditures for the Smithsonian Institution, the U. S. National Museum, the International Exchanges, the Bureau of Ethnology, the National Zoological Park, and the Astrophysical Observatory for the year ending June 30, 1901, and balances of former years:

## SMITHSONIAN INSTITUTION.

### *Condition of the Fund July 1, 1901.*

The amount of the bequest of James Smithson deposited in the Treasury of the United States, according to act of Congress of August 10, 1846, was \$515,169. To this was added by authority of Congress February 8, 1867, the residuary legacy of Smithson, savings from income and other sources, to the amount of \$134,831.

To this also have been added a bequest from James Hamilton, of Pennsylvania, of \$1,000; a bequest of Dr. Simeon Habel, of New York, of \$500; the proceeds of the sale of Virginia bonds, \$51,500; a gift from Thomas G. Hodgkins, of New York, of \$200,000 and \$8,000, being a portion of the residuary legacy of Thomas G. Hodgkins, and \$1,000, the accumulated interest on the Hamilton bequest, making in all, as the permanent fund, \$912,000.

The Institution also holds the additional sum of \$42,000, received upon the death of Thomas G. Hodgkins, in registered West Shore Railroad 4 per cent bonds, which were, by order of this committee, under date of May 18, 1894, placed in the hands of the Secretary of the Institution, to be held by him subject to the conditions of said order.

*Statement of receipts and expenditures from July 1, 1900, to June 30, 1901.*

## RECEIPTS.

Cash on hand July 1, 1900 .....	\$76,219.07	
Interest on fund July 1, 1900.....	\$27,360.00	
Interest on fund January 1, 1901 .....	27,360.00	
	54,720.00	
Interest to January 1, 1901, on West Shore bonds.....	1,680.00	\$132,619.07
Cash from sales of publications.....	188.59	
Cash from repayments, freight, etc .....	10,240.80	
		10,429.39
Total receipts .....		143,048.46

## EXPENDITURES.

Building:		
Repairs, care, and improvements.....	\$6,938.39	
Furniture and fixtures.....	2,188.01	
		\$9,126.40
General expenses:		
Postage and telegraph .....	117.67	
Stationery .....	1,174.44	
Incidentals (fuel, gas, etc.) .....	4,848.20	
Library (books, periodicals, etc.) .....	2,581.80	
Salaries <sup>a</sup> .....	20,566.95	
General printing .....	34.85	
Gallery of art .....	408.92	
Meetings .....	221.37	
		29,954.20
Publications and researches:		
Smithsonian contributions .....	36.85	
Miscellaneous collections .....	1,712.73	
Reports.....	1,971.63	
Special publications .....	222.50	
Researches .....	4,686.04	
Apparatus .....	1,143.10	
Hodgkins fund.....	4,473.51	
		14,246.36
Literary and scientific exchanges.....	5,758.24	
		59,085.20
Balance unexpended June 30, 1901 .....		83,963.26

The cash received from the sale of publications, from repayments for freights, etc., is to be credited to the items of expenditure as follows:

Smithsonian contributions .....	\$24.91	
Miscellaneous collections .....	138.97	
Reports.....	16.41	
Special publications .....	8.30	
		\$188.59
Exchanges.....		9,785.44
Incidentals .....		455.36
		10,429.39

<sup>a</sup> In addition to the above \$20,566.95, paid for salaries under building and general expenses, \$8,999.11 were paid for services, viz, \$4,312.93 charged to building account, \$285 to furniture account, \$2,151.06 to researches account, \$1,250.16 to library account, and \$999.96 to Hodgkins fund account.



The net expenditures of the Institution for the year ending June 30, 1901, were therefore \$48,655.81, or \$10,429.39 less than the gross expenditures, \$59,085.20, as above stated.

All moneys received by the Smithsonian Institution from interest, sales, refunding of moneys temporarily advanced, or otherwise, are deposited with the Treasurer of the United States to the credit of the Secretary of the Institution, and all payments are made by his checks on the Treasurer of the United States.

Your committee also presents the following statements in regard to appropriations and expenditures for objects intrusted by Congress to the Smithsonian Institution:

*Detailed statement of disbursements from appropriations committed by Congress to the care of the Smithsonian Institution for the fiscal year ending June 30, 1901, and from balances of former years.*

## INTERNATIONAL EXCHANGES, SMITHSONIAN INSTITUTION, 1901.

## RECEIPTS.

Appropriated by Congress for the fiscal year ending June 30, 1901, "for expenses of the system of international exchanges between the United States and foreign countries, under the direction of the Smithsonian Institution, including salaries or compensation of all necessary employees and the purchase of necessary books and periodicals, twenty-four thousand dollars" (sundry civil act, June 6, 1900)..... \$24,000.00

## DISBURSEMENTS.

[From July 1, 1900, to June 30, 1901.]

## Salaries or compensation:

1 curator, 4 months, at \$258.33 .....	\$1,033.32
1 acting curator, 5 months, at \$225 .....	1,125.00
1 chief clerk, {6 months, at \$175 .....	} 2,149.98
{6 months, at \$183.33 .....	
1 clerk, 12 months, at \$150 .....	1,800.00
1 clerk, 2 months, at \$125 .....	250.00
1 clerk, {6 months, at \$116.67 .....	} 1,450.02
{6 months, at \$125 .....	
1 clerk, {6 months, at \$100 .....	} 1,249.98
{6 months, at \$108.33 .....	
1 stenographer, {11 months, at \$90 .....	} 1,090.00
{1 month, at \$100 .....	
1 clerk, 12 months, at \$80 .....	960.00
1 {copyist, 6 months, at \$45 .....	} 570.00
{clerk, 6 months, at \$50 .....	
1 packer, 12 months, at \$55 .....	660.00
1 workman, {6 months, at \$50 .....	} 630.00
{6 months, at \$55 .....	
1 messenger, {11 months, at \$25 .....	} 310.00
{1 month, at \$35 .....	
1 laborer, 12 months, at \$45 .....	540.00
1 carpenter, 20 days, at \$3 .....	60.00
1 laborer, 13 days, at \$1.50 .....	19.50

## Salaries or compensation—Continued.

1 laborer, 29 days, at \$1.50 .....	\$43. 50
1 laborer, 22 days, at \$1.50 .....	33. 00
1 cleaner, 166 days, at \$1 .....	166. 00
1 agent, 12 months, at \$91.66 $\frac{2}{3}$ .....	1, 100. 00
1 agent, 12 months, at \$15 .....	180. 00
1 agent, 12 months, at \$50 .....	600. 00

Total salaries or compensation..... 16, 020. 30

## General expenses:

Boxes .....	\$876. 50
Freight .....	3, 587. 12
Postage .....	225. 00
Supplies .....	63. 46
Stationery .....	291. 91

5, 043. 99

Total disbursements .....

\$21, 064. 29

Balance July 1, 1901..... 2, 935. 71

## INTERNATIONAL EXCHANGES, SMITHSONIAN INSTITUTION, 1900.

Balance July 1, 1900, as per last report..... \$2, 538. 83

## DISBURSEMENTS.

## General expenses:

Books .....	\$75. 63
Boxes .....	146. 50
Freight .....	2, 156. 10
Services .....	10. 50
Stationery .....	11. 16
Supplies .....	85. 04

Total disbursements .....

\$2, 484. 93

Balance July 1, 1901..... 53. 90

## INTERNATIONAL EXCHANGES, SMITHSONIAN INSTITUTION, 1899.

Balance July 1, 1900, as per last report..... \$1. 59

Balance carried, under the provisions of Revised Statutes, section 3090, by the Treasury Department to the credit of the surplus fund, June 30, 1901.

## AMERICAN ETHNOLOGY, SMITHSONIAN INSTITUTION, 1901.

## RECEIPTS.

Appropriation by Congress for the fiscal year ending June 30, 1901, "for continuing ethnological researches among the American Indians under the direction of the Smithsonian Institution, including salaries or compensation of all necessary employees and the purchase of necessary books and periodicals, fifty thousand dollars, of which sum not exceeding one thousand five hundred dollars may be used for rent of building" (sundry civil act, June 6, 1900)..... \$50, 000. 00

The actual conduct of these investigations has been continued by the Secretary in the hands of Maj. J. W. Powell, Director of the Bureau of American Ethnology.

## DISBURSEMENTS.

## Salaries or compensation:

1 director, 12 months, at \$375 .....	\$4,500.00
1 ethnologist in charge, 12 months, at \$333.33 .....	3,999.96
1 ethnologist, 7 months, at \$208.33 .....	1,458.31
1 ethnologist, 12 months, at \$200 .....	2,400.00
1 ethnologist, 12 months, at \$166.67 .....	2,000.04
1 ethnologist, 12 months, at \$166.67 .....	2,000.04
1 ethnologist, 12 months, at \$133.33 .....	1,599.96
1 ethnologist, 12 months, at \$125 .....	1,500.00
1 ethnologist, 12 months, at \$125 .....	1,500.00
1 ethnologist, 2½ months, at \$125 .....	312.50
1 assistant ethnologist, 1 month, at \$100 .....	100.00
1 assistant ethnologist, 10 months, at \$50 .....	500.00
1 illustrator, 12 months, at \$166.67 .....	2,000.04
1 ethnologic translator, 6½ months and 6 days, at \$150 ...	1,001.60
1 clerk, 3 months, at \$125 .....	375.00
1 clerk, 12 months, at \$100 .....	1,200.00
1 clerk, 12 months, at \$100 .....	1,200.00
1 clerk, 12 months, at \$100 .....	1,200.00
1 clerk, 12 months, at \$75 .....	900.00
1 proof reader, 12 months, at \$75 .....	900.00
1 assistant ethnologic librarian, 10 months, at \$60; 2 months at \$50 .....	700.00
1 skilled laborer, 12 months, at \$60 .....	720.00
1 messenger, 12 months, at \$50 .....	600.00
1 laborer, 12 months, at \$60 .....	720.00
1 laborer, 12 months, at \$45 .....	540.00
1 laborer, 74 days, at \$1.50 .....	111.00
1 laborer, 28 days, at \$1.50 .....	42.00
Total salaries or compensation .....	\$34,080.45

## General expenses:

Books .....	\$822.58
Drawings and illustrations .....	407.95
Freight .....	257.93
Lighting .....	94.53
Manuscript .....	2,011.00
Miscellaneous .....	108.65
Office furniture .....	683.33
Negatives .....	10.40
Postage and telegraph .....	72.50
Rental .....	1,500.00
Special services .....	526.35
Specimens .....	3,388.78
Supplies .....	1,238.04
Travel and field expenses .....	2,112.82
	<hr/>
	13,234.83
Total disbursements .....	47,315.31
	<hr/>
Balance July 1, 1901 .....	2,684.69

## AMERICAN ETHNOLOGY, 1900.

Balance July 1, 1900, as per last report..... \$2, 147. 35

## DISBURSEMENTS.

## General expenses:

Books .....	\$645. 95
Drawings and illustrations .....	49. 51
Freight .....	67. 89
Office furniture .....	288. 50
Light.....	13. 51
Miscellaneous.....	1. 65
Negatives.....	72. 64
Postage and telegraph .....	21. 32
Rental.....	83. 33
Special services.....	233. 00
Specimens .....	285. 27
Supplies .....	136. 77
Travel and field expenses.....	17. 50
Stationery .....	225. 32

Total disbursements .....

---

\$2, 142. 16

Balance July 1, 1901..... 5. 19

## AMERICAN ETHNOLOGY, 1899.

Balance July 1, 1900, as per last report..... \$92. 48

## DISBURSEMENTS.

## General expenses:

Freight..... \$0. 84

---

Balance .....

---

91. 64

Balance carried, under the provisions of Revised Statutes, section 3090, by the Treasury Department to the credit of the surplus fund, June 30, 1901.

## NATIONAL MUSEUM—PRESERVATION OF COLLECTIONS, 1901.

## RECEIPTS.

Appropriation by Congress for the fiscal year ending June 30, 1901, "for continuing the preservation, exhibition, and increase of the collections from the surveying and exploring expeditions of the Government and from other sources, including salaries or compensation of all necessary employees, \$180,000, of which sum \$5,500 may be used for necessary drawings and illustrations for publications of the National Museum" (sundry civil act, June 6, 1900)..... \$180, 000. 00

## EXPENDITURES.

[July 1, 1900, to June 30, 1901.]

Salaries or compensation..... \$158, 846. 45

Special services .....

---

4, 025. 76

Total services .....

---

\$162, 872. 21

## Miscellaneous:

Drawings and illustrations .....	\$2,010.53	
Supplies .....	4,617.14	
Stationery .....	1,291.37	
Travel.....	1,718.98	
Freight.....	981.85	
		<hr/>
Total miscellaneous .....		\$10,619.87
		<hr/>
Total expenditures .....		\$173,492.08
		<hr/>
Balance July 1, 1901.....		6,507.92

*Analysis of expenditures for salaries or compensation, 1901.*

## Scientific staff:

1 assistant secretary, 8 months, at \$258.33.....	\$2,066.64	
1 head curator, 12 months, at \$291.66.....	3,499.92	
1 curator, 12 months, at \$291.66.....	3,499.92	
1 curator, 12 months, at \$291.66.....	3,499.92	
1 curator, 12 months, at \$200.....	2,400.00	
1 curator, 12 months, at \$200.....	2,400.00	
1 curator, 12 months, at \$200.....	2,400.00	
1 curator, 12 months, at \$200.....	2,400.00	
1 curator, 12 months, at \$175.....	2,100.00	
1 assistant curator, 12 months, at \$150.....	1,800.00	
1 assistant curator, 12 months, at \$150.....	1,800.00	
1 assistant curator, 12 months, at \$150.....	1,800.00	
1 assistant curator, 12 months, at \$150.....	1,800.00	
1 assistant curator, 6 months, at \$150; 6 months, at \$130..	1,680.00	
1 assistant curator, 12 months, at \$133.33.....	1,599.96	
1 assistant curator, 12 months, at \$133.33.....	1,599.96	
1 assistant curator, 12 months, at \$125.....	1,500.00	
1 assistant curator, 12 months, at \$116.66.....	1,399.92	
1 assistant curator, 12 months, at \$116.66.....	1,399.92	
1 second assistant curator, 12 months, at \$100.....	1,200.00	
1 aid, 12 months, at \$116.66.....	1,399.92	
1 aid, 12 months, at \$100.....	1,200.00	
1 aid, 12 months, at \$100.....	1,200.00	
1 aid, 12 months, at \$83.33.....	999.96	
1 aid, 12 months, at \$83.33.....	999.96	
1 aid, 10 months, 54 days, at \$83.33.....	978.45	
1 aid, 12 months, at \$75.....	900.00	
1 aid, 12 months, at \$75.....	900.00	
1 aid, 12 months, at \$50.....	600.00	
1 aid, 11 months, at \$50.....	550.00	
1 aid, 1 month and 15½ days, at \$50.....	75.00	
		<hr/>
		\$51,649.45

## Preparators:

1 photographer, 12 months, at \$175.....	2,100.00
1 modeler, 12 months, at \$100.....	1,200.00
1 modeler, 15 days, at \$3.....	45.00
1 osteologist, 12 months, at \$90.....	1,080.00
1 chemical geologist, 4 months and 25 days, at \$100.....	489.29
1 preparator, 2 months and 41 days, at \$75; 15 days, at \$90.....	295.40

## Preparators—Continued.

1 preparator, 12 months, at \$85.....	\$1,020.00
1 preparator, 12 months, at \$85.....	1,020.00
1 preparator, 12 months, at \$80.....	960.00
1 preparator, 7 months, at \$75.....	525.00
1 preparator, 6 months and 13 days, at \$70.....	452.50
1 preparator, 7 months and 8 days, at \$60.....	437.14
1 preparator, 12 months, at \$45.....	540.00
1 preparator, 6 months and 15 days, at \$45.....	291.77
1 acting chief taxidermist, 1 month and 3 days, at \$125..	137.10
1 taxidermist, 12 months, at \$100.....	1,200.00
1 taxidermist, 12 months, at \$90.....	1,080.00
1 taxidermist, 1 month and 9 days, at \$75.....	96.77
1 taxidermist, 12 months at \$60.....	720.00

---

 \$13,689.97

## Clerical staff:

1 chief clerk, 4 months, at \$208.34; 8 months, at \$208.33..	2,500.00
1 editor, 12 months, at \$167.....	2,004.00
1 chief of division, 12 months, at \$200.....	2,400.00
1 registrar, 12 months, at \$167.....	2,004.00
1 disbursing clerk, 12 months, at \$116.67.....	1,400.04
1 assistant librarian, 12 months, at \$133.33.....	1,599.96
1 stenographer, 12 months, at \$166.66.....	1,999.92
1 stenographer, 12 months, at \$125.....	1,500.00
1 stenographer, 12 months, at \$90.....	1,080.00
1 stenographer, 6 months, at \$85; 6 months, at \$75.....	960.00
1 stenographer and typewriter, 9 months and 11 days, at \$75; 19 days, at \$60; 23 days, at \$2.....	786.50
1 stenographer and typewriter, 11 months and 12 days, at \$50.....	569.35
1 stenographer and typewriter, 8 months and 5 days, at \$50.....	408.06
1 stenographer and typewriter, 3 months and 28 days, at \$50.....	195.16
1 stenographer, 2 months and 48 days, at \$50.....	178.39
1 typewriter, 6 months, at \$85; 6 months, at \$75.....	960.00
1 typewriter, 12 months, at \$70.....	840.00
1 typewriter, 12 months, at \$65.....	780.00
1 typewriter, 10 months and 10 days, at \$45.....	464.52
1 clerk, 12 months, at \$125.....	1,500.00
1 clerk, 12 months, at \$125.....	1,500.00
1 clerk, 6 months, at \$125.....	750.00
1 clerk, 12 months, at \$115.....	1,380.00
1 clerk, 12 months, at \$100.....	1,200.00
1 clerk, 12 months, at \$100.....	1,200.00
1 clerk, 12 months, at \$100.....	1,200.00
1 clerk, 6 months, at \$100; 6 months, at \$90.....	1,140.00
1 clerk, 12 months, at \$80.....	960.00
1 clerk, 12 months, at \$75.....	900.00
1 clerk, 12 months, at \$75.....	900.00
1 clerk, 12 months, at \$75.....	900.00
1 clerk and preparator, 12 months, at \$75.....	900.00
1 clerk, 6 months, at \$75; 6 months, at \$70.....	870.00
1 clerk, 12 months, at \$60.....	720.00
1 acting property clerk, 12 months, at \$60.....	720.00

## Clerical staff—Continued.

1 clerk, 12 months, at \$60.....	\$720. 00
1 clerk and preparator, 12 months, at \$60 .....	720. 00
1 clerk, 6 months, at \$60.....	360. 00
1 clerk, 6 months, at \$60, 6 months, at \$50.....	660. 00
1 clerk, 12 months, at \$55.....	660. 00
1 clerk, 12 months, at \$55.....	660. 00
1 clerk, 7 months and 32 days, at \$55 .....	443. 19
1 clerk, 12 months, at \$50.....	600. 00
1 clerk, 12 months, at \$50.....	600. 00
1 clerk, 10 months and 25 days, at \$50.....	540. 32
1 clerk, 8 months and 83 days, at \$50 .....	536. 77
1 clerk, 12 months, at \$40.....	480. 00
1 clerk, 10 months and 57 days, at \$40 .....	474. 80
1 clerk, 12 months, at \$35.....	420. 00
1 clerk, 6 months and 21 days, at \$30 .....	200. 32
1 copyist, 25 days, at \$50.....	41. 67
1 copyist, 12 months, at \$40.....	480. 00
	\$47, 966. 97

## Buildings and labor:

1 superintendent, 9 months, at \$250 .....	2, 250. 00
1 general foreman, 12 months, at \$122.50.....	1, 470. 00
1 foreman, 12 months, at \$50.....	600. 00
1 carpenter, 8 days, at \$3 .....	24. 00
1 acting captain of watch, 105 days, at \$3.....	315. 00
1 lieutenant of watch, 12 months, at \$70 .....	840. 00
1 watchman, 12 months, at \$65.....	780. 00
1 watchman, 1 month, at \$64; 6 months, at \$60; 46 days, at \$1.50.....	514. 84
1 watchman, 12 months, at \$60.....	720. 00
1 watchman, 12 months, at \$60.....	720. 00
1 watchman, 12 months, at \$60.....	720. 00
1 watchman, 12 months, at \$60.....	720. 00
1 watchman, 12 months, at \$60.....	720. 00
1 watchman, 12 months, at \$60.....	720. 00
1 watchman, 12 months, at \$60.....	720. 00
1 watchman, 12 months, at \$60.....	720. 00
1 watchman, 12 months, at \$60.....	720. 00
1 watchman, 8 months and 10 days, at \$60 .....	499. 35
1 watchman, 6 months and 67 days, at \$60 .....	483. 87
1 watchman, 3 months, at \$60.....	180. 00
1 watchman, 2 months and 15 days, at \$60 .....	147. 50
1 watchman, 12 months, at \$55.....	660. 00
1 watchman, 12 months, at \$55.....	660. 00
1 watchman, 12 months, at \$55.....	660. 00
1 watchman, 12 months, at \$55.....	660. 00
1 watchman, 12 months, at \$55.....	660. 00
1 watchman, 12 months, at \$55.....	660. 00
1 watchman, 12 months, at \$55.....	660. 00
1 watchman, 10 months and 17 days, at \$55 .....	580. 16
1 watchman, 6 months and 17 days, at \$55 .....	360. 16
1 watchman, 4 months and 20 days, at \$55 .....	259. 29
1 watchman, 4 months and 18 days, at \$55 .....	255. 36
1 watchman, 1 month and 9 days, at \$55 .....	70. 97
1 watchman, 12 months, at \$40.....	480. 00

## Buildings and labor—Continued.

1 skilled laborer, 7 months and 15 days, at \$60 .....	\$450.00
1 skilled laborer, 4 months, at \$60 .....	240.00
1 skilled laborer, 8 months and 99 days, at \$55 .....	588.50
1 skilled laborer, 9 months and 16 days, at \$55 .....	523.86
1 skilled laborer, 12 months, at \$50.....	600.00
1 skilled laborer, 1 month, 15 days, at \$50 .....	75.00
1 workman, 310 days, at \$1.50.....	465.00
1 workman, 205½ days, at \$1.50.....	308.25
1 laborer, 1 month, 46 days, at \$50 .....	125.70
1 laborer, 2 months, at \$50.....	100.00
1 laborer, 26 days, at \$50 .....	42.10
1 laborer, 12 months, at \$45 .....	540.00
1 laborer, 1 month, 38 days, at \$45 .....	100.89
1 laborer, 1 month, at \$45 .....	45.00
1 laborer, 31 days, at \$45 .....	46.16
1 laborer, 12 months, at \$40.....	480.00
1 laborer, 12 months, at \$40.....	480.00
1 laborer, 12 months, at \$40.....	480.00
1 laborer, 7 months, at \$40; 131 days, at \$1.50 .....	476.50
1 laborer, 4 months, at \$40.....	160.00
1 laborer, 4 months, at \$40.....	160.00
1 laborer, 3 months, 34 days, at \$40 .....	164.42
1 laborer, 2 months, 15 days, at \$40; 247 days, at \$1.50 ..	470.50
1 laborer, 12 months, at \$35 .....	420.00
1 laborer, 9 months, 44½ days, at \$25.....	261.31
1 laborer, 1 month, at \$25.....	25.00
1 laborer, 5 months, 17 days, at \$20.....	110.97
1 laborer, 3 months, 27 days, at \$20.....	78.00
1 laborer, 336½ days, at \$1.75.....	588.88
1 laborer, 337 days, at \$1.50.....	505.50
1 laborer, 305 days, at \$1.75.....	533.75
1 laborer, 334 days, at \$1.75 .....	584.50
1 laborer, 292 days, at \$1.75.....	511.01
1 laborer, 7 days, \$1.75 .....	12.25
1 laborer, 329½ days, at \$1.50.....	494.25
1 laborer, 324½ days, at \$1.50.....	486.75
1 laborer, 317½ days, at \$1.50.....	476.25
1 laborer, 315 days, at \$1.50.....	472.50
1 laborer, 312½ days, at \$1.50.....	468.75
1 laborer, 312 days, at \$1.50.....	468.00
1 laborer, 312 days, at \$1.50.....	468.00
1 laborer, 312 days, at \$1.50.....	468.00
1 laborer, 312 days, at \$1.50.....	468.00
1 laborer, 310½ days, at \$1.50.....	465.75
1 laborer, 309½ days, at \$1.50.....	464.25
1 laborer, 263 days, at \$1.50 .....	394.50
1 laborer, 221 days, at \$1.50.....	331.50
1 laborer, 156 days, at \$1.50.....	234.00
1 laborer, 105 days, at \$1.50.....	157.50
1 laborer, 105 days, at \$1.50.....	157.50
1 laborer, 104 days, at \$1.50.....	156.00
1 laborer, 97 days, at \$1.50 .....	145.50
1 laborer, 91 days, at \$1.50.....	136.50
1 laborer, 91 days, at \$1.50.....	136.50



## Buildings and labor—Continued.

1 laborer, 79 days, at \$1.50.....	\$118.50
1 laborer, 50 days, at \$1.50.....	75.00
1 laborer, 46 days, at \$1.50.....	69.00
1 laborer, 42 days, at \$1.50.....	63.00
1 laborer, 39 days, at \$1.50.....	58.50
1 laborer, 39 days, at \$1.50.....	58.50
1 laborer, 34½ days, at \$1.50.....	51.75
1 laborer, 34 days, at \$1.50.....	51.00
1 laborer, 31½ days, at \$1.50.....	47.25
1 laborer, 27 days, at \$1.50.....	40.50
1 laborer, 21 days, at \$1.50.....	31.50
1 laborer, 19 days, at \$1.50.....	28.50
1 laborer, 18 days, at \$1.50.....	27.00
1 laborer, 13 days, at \$1.50.....	19.50
1 laborer, 13 days, at \$1.50.....	19.50
1 laborer, 6 days, at \$1.50.....	9.00
1 laborer, 5¾ days, at \$1.50.....	8.63
1 laborer, 5¼ days, at \$1.50.....	7.88
1 laborer, 5 days, at \$1.50.....	7.50
1 laborer, 4 days, at \$1.50.....	6.00
1 laborer, 3½ days, at \$1.50.....	5.25
1 messenger, 10 months, 25 days, at \$60.....	648.39
1 messenger, 23 days, at \$45.....	33.39
1 messenger, 3 months, 20 days, at \$35; 6 months, at \$25.....	278.33
1 messenger, 6 months, at \$35; 1 month, 15 days, at \$25.....	247.50
1 messenger, 5 months, at \$25.....	125.00
1 messenger, 1 month, 28 days, at \$25.....	47.58
1 messenger, 20 days, at \$25.....	16.13
1 messenger, 1 month, at \$20.....	20.00
1 attendant, 12 months, at \$40.....	480.00
1 attendant, 317 days, at \$1.50.....	475.50
1 attendant, 37 days, at \$1.....	37.00
1 attendant, 26 days, at \$1.....	26.00
1 attendant, 18 days, at \$1.....	18.00
1 attendant, 5 days, at \$1.....	5.00
1 attendant, 2 days, at \$1.....	2.00
1 cleaner, 1 month, at \$47; 1 month, at \$41; 3 months, at \$36.50; 5 months, at \$35; 2 months, at \$38.....	448.50
1 cleaner, 3 months, at \$30; 2 months, at \$33; 3 months, at \$31.50; 2 months, at \$34.50; 1 month, at \$36; 1 month at \$36.75.....	392.25
1 cleaner, 12 months, at \$35.....	420.00
1 cleaner, 11 months, 29 days, at \$35.....	418.83
1 cleaner, 12 months, at \$30.....	360.00
1 cleaner, 12 months, at \$30.....	360.00
1 cleaner, 10 months, 60 days, at \$30.....	358.07
1 cleaner, 9 months, 83 days, at \$30.....	352.03
1 cleaner, 2 months, 16 days, at \$30.....	76.00
1 cleaner, 2 months, at \$30.....	60.00
1 cleaner, 17¾ days, at \$1.....	17.75

---

 \$45,540.06

---

 Total expenditure for salaries ..... 158,846.45

## PRESERVATION OF COLLECTIONS, 1900.

## RECEIPTS.

Balance as per report July 1, 1900 ..... \$9,133.82

## EXPENDITURES.

[July 1, 1900, to June 30, 1901.]

Special services.....	\$525.02	
Miscellaneous:		
Supplies .....	\$1,016.14	
Stationery .....	397.07	
Freight .....	383.00	
Travel .....	296.53	
Specimens .....	5,763.18	
Drawings .....	421.49	
		8,277.41
Total expenditures .....		\$8,802.43
Balance July 1, 1901.....		331.39

## PRESERVATION OF COLLECTIONS, 1900.

*Total statement of receipts and expenditures.*

## RECEIPTS.

Appropriation by Congress, act March 3, 1899..... \$170,000.00

## EXPENDITURES.

[July 1, 1899, to June 30, 1901.]

Salaries or compensation .....	\$145,476.10	
Special services .....	1,751.32	
Total services .....	\$147,227.42	
Miscellaneous:		
Drawings and illustrations .....	904.99	
Supplies .....	4,286.47	
Stationery .....	1,800.82	
Specimens .....	10,569.52	
Travel.....	2,360.06	
Freight.....	2,519.33	
Total miscellaneous .....		22,441.19
Total expenditures .....		\$169,668.61
Balance July 1, 1901.....		331.39

## PRESERVATION OF COLLECTIONS, 1899.

Balance as per last report, July 1, 1900..... \$1.53

Balance carried, under the provisions of Revised Statutes, section 3090, by the Treasury Department to the credit of the surplus fund, June 30, 1901.

## NATIONAL MUSEUM—FURNITURE AND FIXTURES, 1901.

## RECEIPTS.

Appropriation by Congress for the fiscal year ending June 30, 1901, "for cases, furniture, fixtures, and appliances required for the exhibition and safe-keeping of the collections of the National Museum, including \$2,500 for furnishing new lecture room and including salaries or compensation of all necessary employees" (sundry civil act, June 6, 1900). \$17,500.00

## EXPENDITURES.

[July 1, 1900, to June 30, 1901.]

	Regular.	Lecture hall.	Total.
Salaries or compensation .....	\$8,083.78	\$547.50	
Special services .....	11.50		
Total services .....	\$8,095.28	\$547.50	\$8,642.78
Miscellaneous:			
Exhibition cases .....	\$95.00		
Storage cases .....	587.00		
Drawers, trays, etc. ....	167.75		
Frames and woodwork .....	311.65	225.22	
Glass .....	345.43		
Hardware .....	388.42	17.17	
Tools .....	106.17		
Cloth .....	98.45	47.13	
Glass jars .....	60.06		
Lumber .....	947.19	82.39	
Paints, oils, etc. ....	250.70	138.51	
Office furniture .....	752.41		
Leather, rubber, and cork .....	209.66		
Drawings for cases .....	41.75	50.00	
Plumbing .....	998.52		
Paper .....	26.16		
Mortar and plaster .....		3.25	
Chairs .....		480.00	
Stereopticon, etc. ....		331.00	
Total miscellaneous .....	\$5,386.32	\$1,374.67	\$6,780.99
Total regular expenditure .....	\$13,481.60		
Total lecture-hall expenditure .....		\$1,922.17	
Total expenditure .....			\$15,403.77
Balance July 1, 1901 .....			\$2,096.23

## FURNITURE AND FIXTURES, 1901.

*Analysis of expenditures for salaries or compensation.*

1 superintendent of construction, 9 months, at \$127.50 .....	\$1,147.50
1 carpenter, 290 days, at \$3 .....	870.00
1 carpenter, 236 days, at \$3 .....	708.00
1 carpenter, 234 days, at \$3 .....	702.00
1 carpenter, 196 days at \$3 .....	588.00
1 carpenter, 127 days, at \$3 .....	381.00
1 carpenter, 100 days, at \$3 .....	300.00
1 carpenter, 90 days, at \$3 .....	270.00
1 carpenter, 78 days, at \$3 .....	234.00
1 carpenter, 34½ days, at \$3 .....	103.50
1 carpenter, 34¼ days, at \$3 .....	102.75
1 carpenter, 33 days, at \$3 .....	99.00
1 carpenter, 26 days, at \$3 .....	78.00
1 carpenter, 19 days, at \$3 .....	57.00
1 carpenter, 18½ days, at \$3 .....	55.50
1 carpenter, 14 days, at \$3 .....	42.00

1 skilled laborer, 5 months, at \$83.33 .....	\$416.65
1 skilled laborer, 1 month, at \$72; 2 months, at \$60 .....	192.00
1 skilled laborer, 3 months, 110 days, at \$65 .....	431.38
1 skilled laborer, 104 days, at \$2 .....	208.00
1 skilled laborer, 54 days, at \$2 .....	108.00
1 skilled laborer, 10 days, at \$2 .....	20.00
1 painter, 5 months, at \$75 .....	375.00
1 workman, 236 days, at \$1.75 .....	413.00
1 laborer, 49 days, at \$1.50 .....	73.50
1 laborer, 45 days, at \$1.50 .....	67.50
1 laborer, 27 days, at \$1.50 .....	40.50

8,083.78

## LECTURE HALL.

1 painter, 1 month, at \$75 .....	75.00
1 carpenter, 45 days, at \$3 .....	135.00
1 carpenter, 27 days, at \$3 .....	81.00
1 carpenter, 20 days, at \$3 .....	60.00
1 carpenter, 18 days, at \$3 .....	54.00
1 skilled laborer, 27 days, at \$2 .....	54.00
1 skilled laborer, 24 days, at \$2 .....	48.00
1 laborer, 27 days, at \$1.50 .....	40.50

547.50

## FURNITURE AND FIXTURES, 1900.

## RECEIPTS.

Balance as per report July 1, 1900..... \$575.24

## EXPENDITURES.

[July 1, 1900, to June 30, 1901.]

	Regular.	Galleries.	Total.
Miscellaneous:			
Drawers, trays, etc .....	\$7.50		\$7.50
Frames .....		\$141.76	141.76
Glass .....		28.80	28.80
Hardware .....	121.91	18.62	140.53
Tools .....	14.65		14.65
Cloth .....	10.25		10.25
Glass jars .....	41.22		41.22
Lumber .....	14.44	97.66	112.10
Paints .....	20.76		20.76
Office furniture .....	9.50		9.50
Iron brackets .....	3.72		3.72
Paper .....	30.00		30.00
Flour .....	2.60		2.60
	276.55	286.84	\$563.39
Balance July 1, 1901 .....			11.85

## FURNITURE AND FIXTURES, 1900.

*Total statement of receipts and expenditures.*

## RECEIPTS.

Appropriation by Congress, act of March 3, 1899 . . . . . \$25,000.00

## EXPENDITURES.

[July 1, 1899, to June 30, 1901.]

	Regular.	Galleries.	Total.
Services:			
Salaries or compensation . . . . .	\$7,853.77	\$3,918.50	
Special services . . . . .	27.22		
Total services . . . . .	7,880.99	3,918.50	\$11,799.49
Miscellaneous:			
Exhibition cases . . . . .	867.00		
Storage cases . . . . .	533.50	1,587.00	2,987.50
Drawers, trays, etc. . . . .	402.40	2,068.50	2,470.90
Frames and woodwork . . . . .	282.72	286.78	569.50
Glass . . . . .	1,166.57	778.20	1,944.77
Hardware . . . . .	726.86	647.95	1,374.81
Tools . . . . .	151.84	4.60	156.44
Cloth . . . . .	68.56	14.00	82.56
Glass jars . . . . .	264.03		264.03
Lumber . . . . .	1,189.87	672.02	1,861.89
Paints, oil, etc. . . . .	537.61	4.00	541.61
Office furniture . . . . .	442.00		442.00
Leather and rubber . . . . .	88.45	8.16	96.61
Iron brackets . . . . .	75.09		75.09
Drawings for cases . . . . .	143.75		143.75
Slate, cement, etc. . . . .	35.50		35.50
Travel . . . . .	2.00		2.00
Linoleum . . . . .	107.10		107.10
Paper . . . . .	30.00		30.00
Flour . . . . .	2.60		2.60
Total regular . . . . .	14,998.41		
Total galleries . . . . .		9,989.71	
Total expenditures . . . . .			\$24,988.15
Balance July 1, 1901 . . . . .			11.85

## FURNITURE AND FIXTURES, 1899.

Balance July 1, 1900, as per last report . . . . . \$1.35

Balance carried, under provisions of section 3090, Revised Statutes, by the Treasury Department to the credit of the surplus fund, June 30, 1901.

## NATIONAL MUSEUM—HEATING AND LIGHTING, ETC., 1901.

## RECEIPTS.

Appropriation by Congress for the fiscal year ending June 30, 1901, "for expense of heating, lighting, electrical, telegraphic, and telephonic service for the National Museum, including \$3,500 for electric installation" (sundry civil act, June 6, 1900) . . . . . \$17,500.00

## EXPENDITURES, REGULAR.

[July 1, 1900, to June 30, 1901.]

Salaries or compensation . . . . . \$6,097.07  
Special services . . . . . 64.60

Total services . . . . . \$6,161.67

Miscellaneous:

Coal and wood .....	\$3,531.85
Gas .....	1,131.90
Rental of call boxes .....	100.00
Electrical supplies .....	311.44
Electricity .....	477.71
Heating supplies .....	501.71
Telegrams .....	29.17
Telephones .....	434.65

Total miscellaneous, regular..... \$6,518.43

Total regular expenditure..... \$12,680.10

ELECTRIC INSTALLATION.

RECEIPTS.

Appropriation, “\* \* \* including \$3,500 for electric installation.”

EXPENDITURES.

Salaries or compensation.....	\$858.40
Special services.....	3.00

Total services .....

\$861.40

Miscellaneous:

Drawings .....	55.50
Supplies .....	1,631.36
Tools .....	20.14
Woodwork .....	328.30
Travel.....	35.11

Total miscellaneous installation .....

2,070.41

Total installation expenditure..... \$2,931.81

Total expenditure .....

\$15,611.91

Balance July 1, 1901..... 1,888.09

HEATING AND LIGHTING, 1901.

*Analysis of expenditures for salaries or compensation.*

1 engineer, 12 months, at \$122.50.....	\$1,470.00
1 telephone operator, 5 months, 17 days, at \$40; 169 days at \$1.50 .....	475.44
1 fireman, 12 months, at \$60 .....	720.00
1 fireman, 12 months, at \$55 .....	660.00
1 skilled laborer, 12 months, at \$75.....	900.00
1 skilled laborer, 12 months, at \$65.....	780.00
1 laborer, 307½ days, at \$1.75.....	538.13
1 laborer, 238 days, at \$1.50.....	357.00
1 laborer, 25 days, at \$1.50.....	37.50
1 coal passer, 106 days, at \$1.50 .....	159.00

\$6,097.07

## Electric installation:

1 acting electrical foreman, 5 months, at \$83.33.....	\$416. 65
1 skilled laborer, 18 days, at \$3.....	54. 00
1 laborer, 79½ days, at \$1.50.....	119. 25
1 laborer, 74 days, at \$1.50.....	111. 00
1 laborer, 52 days, at \$1.50.....	78. 00
1 laborer, 42½ days, at \$1.50.....	63. 75
1 laborer, 10½ days, at 1.50.....	15. 75
	<hr/>
	\$858. 40

## HEATING AND LIGHTING, 1900.

## RECEIPTS.

Balance as per report July 1, 1900.....	\$561. 96
---	-----------

## EXPENDITURES.

[July 1, 1900, to June 30, 1901.]

## Miscellaneous:

Coal and wood.....	\$17. 36
Gas.....	83. 00
Rental of call boxes.....	20. 00
Electrical supplies.....	99. 05
Electricity.....	82. 99
Heating supplies.....	39. 00
Telegrams.....	20. 75
Telephones.....	199. 79
	<hr/>
Total miscellaneous.....	\$561. 94
Balance July 1, 1901.....	. 02

*Total statement of receipts and expenditures.*

## RECEIPTS.

Appropriation by Congress July 1, 1899 (act of March 3, 1899).....	\$14, 000. 00
--	---------------

## EXPENDITURES.

[July 1, 1899, to June 30, 1901.]

Salaries or compensation.....	\$6, 676. 65
Special services.....	8. 00
	<hr/>
Total services.....	\$6, 684. 65
Miscellaneous:	
Coal and wood.....	\$3, 666. 45
Gas.....	1, 208. 10
Rental of call boxes.....	120. 00
Electrical supplies.....	644. 45
Electricity.....	332. 76
Heating supplies.....	723. 53
Telegrams.....	37. 60
Telephones.....	582. 44
	<hr/>
Total miscellaneous.....	7, 315. 33
Total expenditures.....	\$13, 999. 98
Balance July 1, 1901.....	. 02

HEATING AND LIGHTING, 1899.

Balance July 1, 1900, as per last report.....	\$0. 01
Balance carried, under provisions of section 3090, Revised Statutes, by the Treasury Department to the credit of the surplus fund, June 30, 1901	

NATIONAL MUSEUM—POSTAGE, 1901

RECEIPTS.

Appropriation by Congress for the fiscal year ending June 30, 1901, "for postage stamps and foreign postal cards for the National Museum" (sundry civil act June 6, 1900) .....	\$500. 00
---	-----------

EXPENDITURES.

[July 1, 1900, to June 30, 1901.]

For postage stamps and cards.....	\$500. 00
-----------------------------------	-----------

NATIONAL MUSEUM—PRINTING AND BINDING, 1901.

RECEIPTS.

Appropriation by Congress for the fiscal year ending June 30, 1901, "for the Smithsonian Institution, for printing labels and blanks and for the 'Bulletins' and 'Proceedings' of the National Museum, the editions of which shall not be less than three thousand copies, and binding in half turkey or material not more expensive, scientific books and pamphlets presented to and acquired by the National Museum library" .....	\$17, 000. 00
--	---------------

EXPENDITURES.

[July 1, 1900, to June 30, 1901.]

Bulletins of the Museum.....	\$4, 945. 47
Proceedings of the Museum .....	8, 076. 74
Labels.....	584. 82
Blanks.....	252. 72
Envelopes .....	44. 60
Cards.....	50. 09
Binding .....	1, 412. 13
Congressional Record .....	16. 00
Congressional documents .....	188. 34
Report .....	7. 61
Total expenditures .....	<u>\$15, 578. 52</u>
Balance July 1, 1901.....	1, 421. 48

NATIONAL MUSEUM—RENT OF WORKSHOPS, 1901.

RECEIPTS.

Appropriation by Congress for the fiscal year ending June 30, 1901, "for rent of workshops and temporary storage quarters for the National Museum" (sundry civil act, June 6, 1900) .....	\$4, 040. 00
---	--------------



## EXPENDITURES.

[July 1, 1900, to June 30, 1901.]

## Rent of workshops and storage quarters:

No. 431 Ninth street SW .....	\$1,999.92
No. 217 Seventh street SW .....	1,080.00
No. 313 Tenth street SW .....	600.00
No. 915 Virginia avenue SW (rear) .....	360.00
Total expenditures .....	<u>\$4,039.92</u>
Balance July 1, 1901 .....	.08

## RENT OF WORKSHOPS, 1900.

Balance as per report July 1, 1900 .....	\$0.08
Balance July 1, 1901 .....	.08

## RENT OF WORKSHOPS, 1899.

Balance as per last report July 1, 1900 .....	\$110.08
---	----------

Balance carried, under the provisions of the Revised Statutes, section 3090, by the Treasury Department to the credit of the surplus fund, June 30, 1901.

## NATIONAL MUSEUM—BUILDING REPAIRS, 1901.

## RECEIPTS.

Appropriation by Congress for the fiscal year ending June 30, 1901, "for repairs to the buildings, shops, and sheds, National Museum, including repairs of roof, and for all necessary labor and material" (sundry civil act, June 6, 1900) .....	\$15,000.00
---	-------------

## EXPENDITURES.

[July 1, 1900, to June 30, 1901.]

Salaries or compensation .....	\$7,661.44
Special services .....	442.85
Total services .....	<u>\$8,104.29</u>
Miscellaneous:	
Terrazzo and tile floors .....	\$2,037.01
Lumber .....	286.57
Cement, gravel, sand, etc .....	475.60
Hardware and tools .....	170.79
Paints, oils, brushes .....	229.79
Skylights and ventilator .....	240.00
Steel plates, angles, panels, etc .....	1,122.09
Drawings .....	281.50
Advertising .....	41.26
Travel .....	52.35
Woodwork .....	242.62
Bricks .....	59.50
Glass .....	3.80
Decorating walls and ceilings .....	767.90
Total miscellaneous .....	<u>6,010.78</u>
Total expenditures .....	<u>\$14,115.07</u>
Balance July 1, 1901 .....	884.93

BUILDING REPAIRS, 1901.

1 superintendent, 2 months, at \$250 .....	\$500. 00
1 superintendent of construction, 3 months, at \$127.50 .....	382. 50
1 stenographer and typewriter, 22 days, at \$2 .....	44. 00
1 carpenter, 234 $\frac{1}{4}$ days, at \$3 .....	702. 75
1 carpenter, 109 days, at \$3 .....	327. 00
1 carpenter, 105 $\frac{3}{4}$ days, at \$3 .....	317. 25
1 carpenter, 80 days, at \$3 .....	240. 00
1 carpenter, 78 days, at \$3 .....	234. 00
1 carpenter, 26 days, at \$3 .....	78. 00
1 carpenter, 12 days, at \$3 .....	36. 00
1 carpenter, 10 days, at \$3 .....	30. 00
1 carpenter, 4 days, at \$3 .....	12. 00
1 bricklayer, 9 days, at \$4 .....	36. 00
1 bricklayer, 9 days, at \$4 .....	36. 00
1 plumber, 48 days, at \$3.50 .....	168. 00
1 painter, 3 months, 15 days, at \$75 .....	262. 50
1 workman, 78 days, at \$1.75 .....	136. 50
1 skilled laborer, 10 months, 42 $\frac{1}{2}$ days, at \$70 .....	795. 97
1 skilled laborer, 4 months, 19 days, at \$65 .....	301. 17
1 skilled laborer, 124 $\frac{1}{2}$ days, at \$2 .....	249. 00
1 skilled laborer, 4 months, at \$60 .....	240. 00
1 skilled laborer, 118 $\frac{3}{4}$ days, at \$2 .....	237. 00
1 skilled laborer, 94 $\frac{1}{2}$ days, at \$2 .....	189. 00
1 skilled laborer, 2 months, at \$83.33 .....	166. 66
1 skilled laborer, 43 $\frac{1}{2}$ days, at \$2 .....	87. 00
1 skilled laborer, 28 days, at \$3 .....	84. 00
1 skilled laborer, 25 days, at \$2 .....	50. 00
1 skilled laborer, 20 $\frac{1}{2}$ days, at \$2 .....	41. 00
1 skilled laborer, 4 $\frac{1}{2}$ days, at \$2 .....	9. 00
1 laborer, 77 $\frac{1}{2}$ days, at \$1.75 .....	135. 63
1 laborer, 31 $\frac{1}{2}$ days, at \$1.75 .....	55. 13
1 laborer, 253 $\frac{1}{2}$ days, at \$1.50 .....	389. 75
1 laborer, 225 days, at \$1.50 .....	337. 50
1 laborer, 174 $\frac{1}{4}$ days, at \$1.50 .....	261. 38
1 laborer, 86 days, at \$1.50 .....	129. 00
1 laborer, 81 days, at \$1.50 .....	121. 50
1 laborer, 81 days, at \$1.50 .....	121. 50
1 laborer, 44 $\frac{1}{2}$ days, at \$1.50 .....	66. 75
1 laborer, 30 days, at \$1.50 .....	45. 00
1 laborer, 4 days, at \$1.50 .....	6. 00

————— \$7, 661. 44

BUILDING REPAIRS, 1900.

RECEIPTS.

Balance as per report July 1, 1900 .....	\$251. 07
--	-----------

EXPENDITURES.

[July 1, 1900, to June 30, 1901.]

Iron columns .....	\$98. 45
Glass .....	4. 00
Miscellaneous woodwork .....	60. 00
Cement, gravel, mortar, plaster .....	45. 77

Hardware .....	\$15. 50
Paint .....	1. 50
Drawings and plans.....	25. 00
Total .....	<u>\$250. 22</u>
Balance July 1, 1901.....	. 85

## BUILDING REPAIRS, 1900.

*Total statement of receipts and expenditures.*

## RECEIPTS.

Appropriation by Congress March 3, 1899.....	\$6, 000. 00
--	--------------

## EXPENDITURES.

[July 1, 1899, to June 30, 1901.]

Services:	
Salaries or compensation.....	\$1, 833. 55
Miscellaneous:	
Terrazzo floors .....	\$2, 166. 31
Cement, sand, mortar, lime, gravel, etc.....	299. 22
Hardware.....	58. 94
Paints and oils .....	101. 82
Glass .....	162. 31
Steel beams and angles .....	457. 23
Iron columns .....	98. 45
Drawings, decorating walls, etc.....	392. 25
Cloth and paper.....	19. 88
Doors and molding .....	320. 20
Lumber .....	65. 06
Bricks.....	13. 93
Removing dirt .....	10. 00
Total miscellaneous .....	<u>4, 165. 60</u>
Total expenditures .....	<u>\$5, 999. 15</u>
Balance July 1, 1901.....	. 85

## BUILDING REPAIRS, 1899.

Balance as per report July 1, 1900.....	\$0. 91
---	---------

Balance carried, under provisions of Revised Statutes, section 3090, by the Treasury Department to the credit of the surplus fund, June 30, 1901.

## NATIONAL MUSEUM—GALLERIES, 1899.

## RECEIPTS.

Balance as per report July 1, 1900.....	\$205. 79
---	-----------

## EXPENDITURES.

[July 1, 1900, to June 30, 1901.]

Ironwork .....	<u>\$205. 12</u>
Balance.....	67

Balance carried, under the provisions of Revised Statutes, section 3090, by the Treasury Department to the credit of the surplus fund, June 30, 1901.

GALLERIES, 1899.

*Total statement of receipts and expenditures.*

RECEIPTS.

Appropriation by Congress July 1, 1898..... \$10,000.00

EXPENDITURES.

[July 1, 1898, to June 30, 1901.]

Salaries or compensation.....	\$940.56
Ransome arches.....	1,609.38
Ironwork.....	3,527.35
Terrazzo and marble floor.....	1,295.09
Hardware and tools.....	54.56
Lumber.....	103.34
Cement, etc.....	234.45
Drawings and blue prints.....	85.00
Advertising.....	61.07
Paint.....	25.65
Bricks.....	46.00
Woodwork.....	156.00
Canvas.....	29.21
Skylight and ventilators.....	1,782.20
Travel.....	23.10
Sheeting.....	21.12
Paper.....	5.25
Total expenditures.....	<u>\$9,999.33</u>
Balance.....	67

Balance carried, under the provisions of Revised Statutes, section 3090, by the Treasury Department to the credit of the surplus fund, June 30, 1901.

NATIONAL MUSEUM—BOOKS, 1901.

RECEIPTS.

Appropriation by Congress for the fiscal year ending June 30, 1901, "for purchase of books, pamphlets, and periodicals for reference in the National Museum" (sundry civil act, June 6, 1900)..... \$2,000.00

EXPENDITURES.

[July 1, 1900, to June 30, 1901.]

For purchase of books, pamphlets, and periodicals from July 1, 1900, to June 30, 1901..... \$1,141.96

Balance July 1, 1901..... 858.04

BOOKS, 1900.

RECEIPTS.

Balance as per report July 1, 1900..... \$878.72

EXPENDITURES.

[July 1, 1900, to June 30, 1901.]

For purchase of books, pamphlets, and periodicals from July 1, 1900, to June 30, 1901..... \$848.08

Balance July 1, 1901..... 30.64

## BOOKS, 1900.

*Total statement of receipts and expenditures.*

## RECEIPTS.

Appropriation by Congress March 3, 1899.....	\$2,000.00
--	------------

## EXPENDITURES.

[July 1, 1899, to July 30, 1901.]

For purchase of books, pamphlets, and periodicals.....	\$1,969.36
Balance July 1, 1901.....	30.64

## BOOKS, 1899.

## RECEIPTS.

Balance as per report July 1, 1900.....	\$25.08
---	---------

## EXPENDITURES.

[July 1, 1900, to June 30, 1901.]

For purchase of books, pamphlets, and periodicals.....	\$17.25
Balance.....	7.83

Balance carried, under provisions of Revised Statutes, section 3090, by the Treasury Department to the credit of the surplus fund, June 30, 1901.

## BOOKS, 1899.

*Total statement of receipts and expenditures.*

## RECEIPTS.

Appropriation by Congress July 1, 1898.....	\$2,000.00
---	------------

## EXPENDITURES.

[July 1, 1898, to June 30, 1901.]

For purchase of books, pamphlets, and periodicals.....	\$1,992.17
Balance.....	7.83

Balance carried, under provisions of Revised Statutes, section 3090, by the Treasury Department to the credit of the surplus fund, June 30, 1901.

## NATIONAL MUSEUM—PURCHASE OF SPECIMENS, 1901.

## RECEIPTS.

Appropriation by Congress for the fiscal year ending June 30, 1901, "for purchase of specimens to supply deficiencies in the collections of the National Museum" (sundry civil act, June 6, 1900).....	\$10,000.00
--	-------------

## EXPENDITURES.

[July 1, 1900, to June 30, 1901.]

For purchase of specimens.....	\$6,941.44
Balance July 1, 1901.....	3,058.56

ASTROPHYSICAL OBSERVATORY, SMITHSONIAN INSTITUTION, 1901.

RECEIPTS.

Appropriation by Congress for the fiscal year ending June 30, 1901, "for maintenance of Astrophysical Observatory, under the direction of the Smithsonian Institution, including salaries of assistants, the purchase of necessary books and periodicals, apparatus, printing and publishing results of researches, not exceeding one thousand five hundred copies, repairs and alterations of buildings, and miscellaneous expenses, twelve thousand dollars" (sundry civil act, June 6, 1900) ..... \$12,000.00

DISBURSEMENTS.

Salaries or compensation:

1 aid, 12 months, at \$175.....	\$2,100.00
1 clerk, 1 month, at \$125.....	125.00
1 junior assistant, 12 months, at \$110.....	1,320.00
1 stenographer, 12 months, at \$100.....	1,200.00
1 instrument-maker, 9 months, at \$80.....	720.00
1 fireman, 12 months, at \$50.....	600.00
1 photographer, 29 days, at \$4.50.....	130.50
5 carpenters, 22 days, at \$3.....	66.00
2 painters, 6 days, at \$2.80.....	16.80
2 painters, 6 days, at \$2.....	12.00
1 skilled laborer, 4½ days, at \$70 per month...	10.16
1 laborer, 5 days, at \$1.75.....	8.75
6 laborers, 98½ days, at \$1.50.....	147.75
1 cleaner, 166 days, at \$1.....	166.00
	<hr/>
Total salaries or compensation.....	\$6,622.96

General expenses:

Apparatus.....	\$1,417.43
Books.....	98.69
Electric power.....	116.70
Freight.....	5.00
Fuel.....	61.80
Drawings and illustrations.....	16.40
Lumber.....	19.88
Reports.....	3,106.34
Stationery, supplies, etc.....	321.98
Traveling expenses.....	133.02
	<hr/>
	5,297.24

Total disbursements..... \$11,920.20

Balance July 1, 1901..... 79.80

ASTROPHYSICAL OBSERVATORY, 1900.

Balance July 1, 1900, as per last report..... \$1,215.78

DISBURSEMENTS.

General expenses:

Apparatus.....	\$880.00
Books.....	30.42
Freight.....	18.86
Fuel.....	27.30
Drawings.....	20.00

## General expenses—Continued.

Electric power .....	\$54.59
Lumber .....	3.36
Postage and telegraph .....	.99
Services .....	6.00
Supplies .....	154.27
Traveling expenses .....	17.00
Total disbursements .....	<u>\$1,212.79</u>
Balance July 1, 1901 .....	2.99

## ASTROPHYSICAL OBSERVATORY, 1899.

Balance as per last report, July 1, 1900..... \$3.97

Balance carried, under the provisions of Revised Statutes, section 3090, by the Treasury Department to the credit of the surplus fund, June 30, 1901.

## OBSERVATION OF ECLIPSE OF MAY 28, 1900.

Balance July 1, 1900, as per last report..... \$1,529.20

## DISBURSEMENTS.

## General expenses:

Apparatus .....	\$437.64
Freight .....	62.75
Supplies .....	47.39
Telephone and telegraph .....	33.48
Transportation .....	3.00
Travel and field expenses .....	189.20
Total disbursements .....	<u>\$773.46</u>
Balance July 1, 1901 .....	755.74

## NATIONAL ZOOLOGICAL PARK, 1901.

## RECEIPTS.

Appropriation by Congress for the fiscal year ending June 30, 1901, "for continuing the construction of roads, walks, bridges, water supply, sewerage and drainage; and for grading, planting, and otherwise improving the grounds; erecting and repairing buildings and inclosures; care, subsistence, purchase, and transportation of animals, including salaries or compensation of all necessary employees, the purchase of necessary books and periodicals, and general incidental expenses not otherwise provided for, seventy-five thousand dollars; one-half of which sum shall be paid from the revenues of the District of Columbia and the other half from the Treasury of the United States; and of the sum hereby appropriated, five thousand dollars shall be used for continuing the entrance into the Zoological Park from Cathedral avenue, and opening driveway into Zoological Park, including necessary grading and removal of earth: *Provided*, That the unexpended balance of the amounts, aggregating eight thousand dollars, heretofore appropriated for widening, grading, and regulating Adams Mill road from Columbia road to the Zoological Park entrance, is hereby reappropriated, to be expended under the direction of the Commissioners of the District of Columbia; and that the control of Adams Mill road is hereby vested in the said Commissioners, and all proceedings necessary to purchase

or condemn the land necessary to widen said road as authorized by act approved March third, eighteen hundred and ninety-nine, providing for sundry civil expenses of the Government for the fiscal year ending June thirtieth, nineteen hundred, and for other purposes, shall be taken by said Commissioners?" (sundry civil act, June 6, 1900) ..... \$75,000.00

## DISBURSEMENTS.

## Salaries or compensation:

1 superintendent, 12 months, at \$225 .....	\$2,700.00
1 property clerk, 12 months, at \$150 .....	1,800.00
1 clerk, {6 months, at \$90 .....	1,200
{6 months, at \$110 .....	
1 copyist, 12 months, at \$90 .....	1,080.00
1 copyist, 3 days, at \$1.50 .....	4.50
1 stenographer, 12 months, at \$62.50 .....	750.00
1 head keeper, 12 months, at \$100 .....	1,200.00
1 keeper, 12 months, at \$60 .....	720.00
1 keeper, 12 months, at \$60 .....	720.00
1 keeper, 12 months, at \$60 .....	720.00
1 keeper, 12 months, at \$60 .....	720.00
1 landscape gardener, 5½ months, at \$75; 2 months, 8 days, at \$83.33 .....	601.38
1 assistant foreman, 6 months, at \$60; 6 months, at \$65 .....	750.00
1 watchman, 12 months, at \$60 .....	720.00
1 watchman, 12 months, at \$60 .....	720.00
1 watchman, {6 months, at \$50 .....	630.00
{6 months, at \$55 .....	
1 blacksmith, 12 months, at \$75 .....	900.00
1 assistant blacksmith, 12 months, at \$60 .....	720.00
1 workman, 12 months, at \$60 .....	720.00
1 workman, 12 months, at \$50 .....	600.00
1 laborer, 12 months, at \$60 .....	720.00
1 laborer, 10½ months and 9 days, at \$50 .....	539.52
1 laborer, {6 months, at \$50 .....	630.00
{6 months, at \$55 .....	
1 laborer, 11½ months, at \$50 .....	575.00
1 laborer, 2½ months and 12 days, at \$20 .....	58.00

Total salaries or compensation..... \$20,498.40

## Miscellaneous:

Buildings .....	1,392.39
Building material .....	78.34
Cameras .....	363.15
Fencing, cage materials, etc. ....	1,099.17
Food .....	8,745.45
Freight .....	457.33
Fuel .....	841.33
Furniture .....	243.00
Illustrations .....	15.00
Lumber .....	1,122.12
Machinery, tools, etc. ....	480.53
Miscellaneous .....	837.50
Paints, oils, glass, etc. ....	219.32
Postage and telegraph .....	174.95



## Miscellaneous—Continued.

Purchase of animals .....	\$2, 634. 68
Road materials and grading .....	981. 61
Stationery, books, etc. ....	133. 63
Surveying, plans, etc. ....	622. 00
Traveling and field expenses .....	454. 41
Trees, plants, etc. ....	13. 10
Water supply, sewerage, etc. ....	552. 32

Total miscellaneous. .... \$21, 460. 33

Wages of mechanics and laborers and hire of teams in constructing buildings and inclosures, laying water pipes, building roads, gutters, and walks, planting trees, and otherwise improving the grounds:

1 carpenter, 56 days, at \$3 .....	168. 00
1 carpenter, 29½ days, at \$3 .....	88. 50
1 carpenter, 29 days, at \$3 .....	87. 00
1 carpenter, 27 days, at \$3 .....	81. 00
1 carpenter, 24 days, at \$3 .....	72. 00
1 carpenter, 14 days, at \$3 .....	42. 00
1 carpenter, 13 days, at \$3 .....	39. 00
1 carpenter, 39½ days, at \$3 .....	118. 50
1 carpenter, 29½ days, at \$3 .....	88. 50
1 carpenter, 29½ days, at \$3 .....	88. 50
1 carpenter, 24 days, at \$3 .....	72. 00
1 carpenter, 8 days, at \$3 .....	24. 00
1 carpenter, 29½ days, at \$3 .....	88. 50
1 carpenter, 297½ days, at \$3 .....	892. 50
1 painter, 18 days, at \$3 .....	54. 00
1 {laborer, 5¾ days, at \$1.50 } {painter, 71¾ days, at \$3. } .....	222. 37
1 painter, 4 days, at \$3 .....	12. 00
1 painter, 4 days, at \$3 .....	12. 00
1 painter, 3 days, at \$3. ....	9. 00
1 timer, 35¼ days, at \$2.50 .....	88. 12
1 laborer, 365 days, at \$2.50 .....	912. 50
1 laborer, 121 days, at \$2.50 .....	302. 50
1 laborer, 283¾ days, at \$2 .....	567. 50
1 laborer, 365 days, at \$2 .....	730. 00
1 laborer, 6 days, at \$2 .....	12. 00
1 laborer {11 days, at \$2 ..... } {264¾ days, at \$1.50 } .....	419. 14
1 workman, 365 days, at \$1.75 .....	638. 75
1 laborer, 133¾ days, at \$1.75 .....	234. 06
1 laborer, 365 days, at 1.75 .....	638. 75
1 laborer, 341½ days, at \$1.75 .....	597. 64
1 laborer, 286 days, at \$1.75 .....	500. 50
1 laborer, 303 days, at \$1.75 .....	530. 25
1 laborer, 253¼ days, at \$1.75 .....	443. 21
1 laborer, 365½ days, at \$1.50 .....	548. 26
1 laborer, 4 days, at \$1.50 .....	6. 00
1 laborer, 276¾ days, at \$1.50 .....	415. 13
1 laborer, 67¾ days, at \$1.50 .....	101. 64

## Wages of mechanics and laborers, etc.—Continued.

1 laborer, 365 $\frac{3}{4}$ days, at \$1.50.....	\$548.63
1 laborer {190 days, at \$1.50.. } {179 $\frac{1}{4}$ days, at \$1.75. }	598.68
1 laborer, 372 days, at \$1.50.....	558.02
1 laborer, 282 $\frac{1}{2}$ days, at \$1.50.....	423.77
1 laborer, 278 $\frac{3}{4}$ days, at \$1.50.....	418.14
1 laborer, 258 days, at \$1.50.....	387.01
1 laborer, 234 $\frac{1}{4}$ days, at \$1.50.....	351.38
1 laborer, 228 $\frac{1}{4}$ days, at \$1.50.....	342.39
1 laborer, 196 $\frac{1}{4}$ days, at \$1.50.....	294.37
1 laborer, 195 $\frac{3}{4}$ days, at \$1.50.....	293.62
1 laborer, 171 $\frac{3}{4}$ days, at \$1.50.....	257.63
1 laborer, 102 $\frac{3}{4}$ days, at \$1.50.....	154.13
1 laborer, 125 $\frac{1}{4}$ days, at \$1.50.....	187.88
1 laborer, 14 $\frac{1}{2}$ days, at \$1.50.....	21.75
1 laborer, 25 $\frac{1}{2}$ days, at \$1.50.....	38.25
1 laborer, 81 days, at \$1.50.....	121.50
1 laborer, 100 $\frac{3}{4}$ days, at \$1.50.....	151.13
1 laborer, 199 days, at \$1.50.....	298.50
1 laborer, 23 $\frac{3}{4}$ days, at \$1.50.....	35.63
1 laborer, 339 days, at \$1.50.....	508.50
1 laborer, 28 $\frac{3}{4}$ days, at \$1.50.....	43.12
1 laborer, 23 days, at \$1.50.....	34.50
1 laborer, 20 days, at \$1.50.....	30.00
1 laborer, 5 days, at \$1.50.....	7.50
1 laborer, 103 $\frac{1}{4}$ days, at \$1.50.....	154.88
1 laborer, 313 $\frac{1}{4}$ days, at \$1.50.....	469.88
1 laborer, 94 $\frac{1}{4}$ days, at \$1.50.....	141.38
1 laborer, 4 days, at \$1.50.....	6.00
1 laborer, 338 $\frac{3}{4}$ days, at \$1.50.....	508.13
1 laborer, 67 days, at \$1.50.....	100.50
1 laborer, 59 $\frac{1}{4}$ days, at \$1.50.....	88.88
1 laborer {25 days, at \$1.25 } {57 $\frac{1}{4}$ days, at \$1.50 }	117.13
1 laborer, 41 days, at \$1.50.....	61.50
1 laborer, 13 days at \$1.50.....	19.50
1 laborer, 8 days, at \$1.50.....	12.00
1 laborer, 4 days, at \$1.50.....	6.00
1 laborer, 2 $\frac{1}{2}$ days, at \$1.50.....	3.75
1 laborer, 2 days, at \$1.50.....	3.00
1 laborer, 56 $\frac{1}{4}$ days, at \$1.25.....	70.31
1 laborer {32 days, at \$1..... } {356 $\frac{1}{4}$ days, at \$1.25. }	477.33
1 laborer, 14 $\frac{1}{2}$ days, at \$1.25.....	18.12
1 laborer, 365 days, at \$1.25.....	456.25
1 laborer, 44 $\frac{1}{4}$ days, at \$1.25.....	55.32
1 laborer, 11 $\frac{1}{4}$ days, at \$1.25.....	14.06
1 laborer, 11 $\frac{1}{4}$ days, at \$1.25.....	14.06
1 laborer, 322 $\frac{3}{4}$ days, at \$1.....	322.75
1 laborer, 263 $\frac{3}{4}$ days, at \$1.....	263.75
1 laborer, 252 $\frac{3}{4}$ days, at \$1.....	252.75
1 laborer, 61 $\frac{3}{4}$ days, at \$1.....	61.75
1 laborer, 5 $\frac{3}{4}$ days, at \$1.....	5.75

## Wages of mechanics and laborers, etc.—Continued.

1 laborer {5 $\frac{3}{4}$ days, at 75 cents}	} -----	\$33.32
{29 days, at \$1.....}		
1 laborer, 4 $\frac{3}{4}$ days, at 75 cents .....		3.56
1 laborer, 12 $\frac{1}{4}$ days, at \$1.50 .....		18.37
1 laborer {56 $\frac{1}{2}$ days, at \$1.25}	} -----	115.63
{30 days, at \$1.50}		
1 laborer, 12 $\frac{1}{4}$ days, at \$1.50 .....		181.87
1 laborer, 12 $\frac{1}{2}$ days, at \$1.25 .....		15.63
1 {attendant {185 days, at 75 cents...}	} -----	316.75
{laborer {178 days, at \$1.....}		
1 attendant, 278 days, at 75 cents .....		208.50
1 attendant, at 75 cents .....		.75
1 attendant, 93 days, at 75 cents .....		69.75
1 {attendant {247 $\frac{1}{2}$ days, at 75 cents}	} -----	307.89
{laborer {122 $\frac{1}{2}$ days, at \$1.....}		
1 attendant, 26 $\frac{1}{4}$ days, at 50 cents .....		13.12
1 weeder, 188 days, at 75 cents .....		141.03
1 water boy, 121 days, at 50 cents .....		60.50
1 water boy, 219 $\frac{3}{4}$ days, at 50 cents .....		109.89
1 water boy, 342 $\frac{3}{4}$ days, at 50 cents .....		171.38
1 water boy, 12 days, at 50 cents .....		6.00
1 water boy, 61 days, at 50 cents .....		30.50
1 water boy, 49 days, at 50 cents .....		24.50
1 water boy, 28 $\frac{3}{4}$ days, at 50 cents .....		14.37
1 water boy, 12 $\frac{1}{2}$ days, at 50 cents .....		6.25
1 wagon and team, $\frac{3}{4}$ day, at \$3.....		2.25
1 wagon and team, 22 $\frac{1}{2}$ days, at \$3.....		67.50
1 wagon and team, 194 $\frac{1}{4}$ days, at \$3.....		582.75
1 wagon and team, 5 $\frac{1}{2}$ days, at \$3.....		16.50
1 horse and cart, 155 $\frac{3}{4}$ days, at \$1.50 .....		233.62
1 horse and cart, 30 $\frac{1}{4}$ days, at \$1.50 .....		45.37
1 horse and cart, 67 $\frac{1}{2}$ days, at \$1.50 .....		101.25
1 horse and cart, 8 days, at \$1.50 .....		12.00
1 horse and cart, 11 $\frac{1}{4}$ days, at \$1.50 .....		16.88
1 horse and cart, 16 $\frac{1}{2}$ days, at \$1.50 .....		24.75
1 horse and cart, 29 $\frac{1}{2}$ days, at \$1.50 .....		44.25
1 horse and cart, 17 $\frac{3}{4}$ days, at \$1.50 .....		26.63
1 horse and cart, 8 days, at \$1.50 .....		12.00
1 horse and cart, 7 days, at \$1.50 .....		10.50
1 horse and cart, 7 days, at \$1.50 .....		10.50
1 horse, 1 $\frac{1}{2}$ days, at \$1 .....		1.50
1 horse, 297 $\frac{3}{4}$ days, at 50 cents .....		148.88
1 {stonebreaker, 137 cubic yards, at 60 cents }	} -----	209.71
{laborer, 85 days, at \$1.50.....}		
1 stonebreaker, 92 $\frac{3}{4}$ cubic yards, at 60 cents ...		55.65
1 stonebreaker, 34 $\frac{1}{2}$ cubic yards, at 60 cents ...		20.70
Total wages of mechanics, etc .....		\$23, 238.98
Total disbursements .....		\$65, 197.71
Balance July 1, 1901 .....		9, 802.29

## NATIONAL ZOOLOGICAL PARK, 1900.

Balance July 1, 1900, as per last report.....	\$14,907.46	
Transferred to Commissioners District of Columbia (sundry civil act, June 6, 1900).....	5,000.00	\$9,907.46

## DISBURSEMENTS.

General expenses:		
Buildings.....	\$115.20	
Books.....	318.65	
Cameras.....	445.00	
Fencing and cage material.....	1,046.35	
Food.....	1,288.92	
Fuel.....	145.39	
Furniture.....	60.00	
Freight.....	689.13	
Lumber.....	328.83	
Machinery, tools, etc.....	261.97	
Miscellaneous.....	122.87	
Paints, oil, glass, etc.....	40.97	
Postage, telephone, and telegraph.....	75.94	
Purchase of animals.....	236.00	
Road material and grading.....	1,338.84	
Special services.....	480.00	
Surveying, plans, etc.....	984.00	
Traveling and field expenses.....	629.23	
Trees, plants, etc.....	710.60	
Water supply, sewerage, etc.....	195.27	
Total disbursements.....		\$9,513.16
Balance.....		394.30

## NATIONAL ZOOLOGICAL PARK, 1899.

Balance July 1, 1900, as per last report.....	\$82.31
---	---------

## DISBURSEMENTS.

General expenses:		
Books.....	\$3.18	
Miscellaneous.....	13.67	
Special services.....	50.00	
Postage.....	2.00	
Total disbursements.....		\$68.85
Balance.....		13.46

Balance carried under the provisions of Revised Statutes, section 3090, by the Treasury Department to the credit of the surplus fund, June 30, 1901.

## RECAPITULATION.

The total amount of funds administered by the Institution during the year ending June 30, 1901, appears from the foregoing statements and the account books to have been as follows:

## SMITHSONIAN INSTITUTION.

From balance of last year, July 1, 1900.....	\$76,219.07
From interest on Smithsonian fund for the year.....	54,720.00
From interest on West Shore bonds.....	1,680.00
From sales of publications.....	188.59
From repayments of freight, etc.....	10,240.80
	<u>\$143,048.46</u>

## APPROPRIATIONS COMMITTED BY CONGRESS TO THE CARE OF THE INSTITUTION.

International exchanges—Smithsonian Institution:		
From balance of 1898-99.....	\$1.59	
From balance of 1899-1900.....	2,538.83	
From appropriation for 1900-1901.....	24,000.00	
		\$26,540.42
American ethnology—Smithsonian Institution:		
From balance of 1898-99.....	92.48	
From balance of 1899-1900.....	2,147.35	
From appropriation for 1900-1901.....	50,000.00	
		52,239.83
Preservation of collections—National Museum:		
From balance of 1898-99.....	1.53	
From balance of 1899-1900.....	9,133.82	
From appropriation for 1900-1901.....	180,000.00	
		189,135.35
Furniture and fixtures—National Museum:		
From balance of 1898-99.....	1.35	
From balance of 1899-1900.....	575.24	
From appropriation for 1900-1901.....	17,500.00	
		18,076.59
Heating and lighting, etc.—National Museum:		
From balance of 1898-99.....	.01	
From balance of 1899-1900.....	561.96	
From appropriation for 1900-1901.....	17,500.00	
		18,061.97
Postage—National Museum:		
From appropriation for 1900-1901.....		500.00
Printing—National Museum:		
From appropriation for 1900-1901.....		17,000.00
Rent of workshops, etc.—National Museum:		
From balance of 1898-99.....	110.08	
From balance of 1899-1900.....	.08	
From appropriation for 1900-1901.....	4,040.00	
		4,150.16
Building repairs—National Museum:		
From balance of 1898-99.....	.91	
From balance of 1899-1900.....	251.07	
From appropriation for 1900-1901.....	15,000.00	
		15,251.98
Galleries—National Museum:		
From balance of 1898-99.....		205.79
Books—National Museum:		
From balance of 1898-99.....	25.08	
From balance of 1899-1900.....	878.72	
From appropriation for 1900-1901.....	2,000.00	
		2,903.80
Purchase of specimens—National Museum:		
From appropriation for 1900-1901.....		10,000.00
Astrophysical Observatory—Smithsonian Institution:		
From balance of 1898-99.....	3.97	
From balance of 1899-1900.....	1,215.78	
From appropriation for 1900-1901.....	12,000.00	
		13,219.75
Observation of eclipse of May 28, 1900:		
From balance July 1, 1900.....		1,529.20
National Zoological Park:		
From balance of 1898-99.....	82.31	
From balance of 1899-1900.....	9,907.46	
From appropriation for 1900-1901.....	75,000.00	
		84,989.77

## SUMMARY.

Smithsonian Institution.....	\$143,048.46
Exchanges.....	26,540.42
Ethnology.....	52,239.83
Preservation of collections.....	189,135.35
Furniture and fixtures.....	18,076.59
Heating and lighting.....	18,061.97
Postage.....	500.00
Printing.....	17,000.00
Rent of workshops.....	4,150.16
Building repairs.....	15,251.98
Galleries.....	205.79
Books.....	2,903.80
Purchase of specimens.....	10,000.00
Astrophysical Observatory.....	13,219.75
Observation of eclipse of May 28, 1900.....	1,529.20
National Zoological Park.....	84,989.77
	596,853.07

The committee has examined the vouchers for payment from the Smithsonian income during the year ending June 30, 1901, each of which bears the approval of the Secretary or, in his absence, of the acting Secretary, and a certificate that the materials and services charged were applied to the purposes of the Institution.

The committee has also examined the accounts of the several appropriations committed by Congress to the Institution, and finds that the balances hereinbefore given correspond with the certificates of the disbursing clerk of the Smithsonian Institution, whose appointment as such disbursing officer has been accepted and his bond approved by the Secretary of the Treasury.

The quarterly accounts current, the vouchers, and journals have been examined and found correct.

*Statement of regular income from the Smithsonian fund available for use in the year ending June 30, 1902.*

Balance July 1, 1901.....	\$83,963.26
(Including cash from executors of J. H. Kidder).....	\$5,000.00
(Including cash from Dr. Alex. Graham Bell).....	5,000.00
	10,000.00
Interest due and receivable July 1, 1901.....	27,360.00
Interest due and receivable January 1, 1902.....	27,360.00
Interest, West Shore Railroad bonds, due July 1, 1901.....	840.00
Interest, West Shore Railroad bonds, due January 1, 1902.....	840.00
	56,400.00
Total available for year ending June 30, 1902.....	140,363.26

Respectfully submitted,

J. B. HENDERSON,  
ALEXANDER GRAHAM BELL,  
ROBERT R. HITT,  
*Executive Committee.*

WASHINGTON, D. C., *January 14, 1902.*

# ACTS AND RESOLUTIONS OF CONGRESS RELATIVE TO THE SMITHSONIAN INSTITUTION, ETC.

[Continued from previous Reports.]

---

[Fifty-sixth Congress, second session.]

## SMITHSONIAN INSTITUTION.

*Resolved by the Senate and House of Representatives of the United States of America in Congress assembled,* That the vacancy in the Board of Regents of the Smithsonian Institution of the class other than members of Congress, caused by the death of William Lyne Wilson, of Virginia, shall be filled by the appointment of George Gray, a resident of Delaware. (Approved January 14, 1901; Statutes, XXXI, 1459.)

That facilities for study and research in the Government Departments, the Library of Congress, the National Museum, the Zoological Park, the Bureau of Ethnology, the Fish Commission, the Botanic Gardens, and similar institutions hereafter established shall be afforded to scientific investigators and to duly qualified individuals, students, and graduates of institutions of learning in the several States and Territories, as well as in the District of Columbia, under such rules and restrictions as the heads of the Departments and Bureaus mentioned may prescribe. (Approved March 3, 1901; Statutes, XXXI, 1039.)

SMITHSONIAN DEPOSIT [LIBRARY OF CONGRESS].—For custodian, one thousand five hundred dollars; one assistant, one thousand two hundred dollars; one messenger, seven hundred and twenty dollars; one messenger boy, three hundred and sixty dollars; in all, three thousand seven hundred and eighty dollars. (Approved March 3, 1901; Statutes, XXXI, 970.)

## INTERNATIONAL EXCHANGES.

For expenses of the system of international exchanges between the United States and foreign countries, under the direction of the Smithsonian Institution, including salaries or compensation of all necessary employees, and the purchase of necessary books and periodicals,

twenty-four thousand dollars. (Approved March 3, 1901; Statutes, XXXI, 1146.)

TREASURY DEPARTMENT, CONTINGENT EXPENSES.—To pay the account of the Smithsonian Institution for the transmission of mail matter for the Treasury Department for the fiscal years as follows:

For the fiscal year nineteen hundred and one, two hundred and forty-four dollars and five cents.

For the fiscal year nineteen hundred, four hundred and fifty-three dollars and fifty cents. (Approved March 3, 1901; Statutes, XXXI, 1012.)

#### NATIONAL MUSEUM.

For cases, furniture, fixtures, and appliances required for the exhibition and safe-keeping of the collections of the National Museum, including salaries or compensation of all necessary employees, twenty thousand dollars.

For expense of heating, lighting, electrical, telegraphic, and telephonic service for the National Museum, including five thousand dollars for electric installation, twenty-three thousand dollars.

For removing old boilers in the National Museum building, and for the purchase and installation of new boilers, including material and labor for necessary alterations and connections, twelve thousand five hundred dollars.

For continuing the preservation, exhibition, and increase of the collections from the surveying and exploring expeditions of the Government, and from other sources, including salaries or compensation of all necessary employees, one hundred and eighty thousand dollars, of which sum five thousand five hundred dollars may be used for necessary drawings and illustrations for publications of the National Museum; and all other necessary incidental expenses.

For purchase of specimens to supply deficiencies in the collections of the National Museum, ten thousand dollars.

For purchase of books, pamphlets, and periodicals for reference in the National Museum, two thousand dollars.

For repairs to buildings, shops, and sheds, National Museum, including all necessary labor and material, fifteen thousand dollars.

For construction of two galleries in the National Museum building, five thousand dollars.

For rent of workshops and temporary storage quarters for the National Museum, four thousand four hundred dollars.

For postage stamps and foreign postal cards for the National Museum, five hundred dollars. (Approved March 3, 1901; Statutes, XXXI, 1147.)

For the Smithsonian Institution, for printing labels and blanks, and for the "Bulletins" and "Proceedings" of the National Museum, the



editions of which shall not be less than three thousand copies, and binding, in half turkey, or material not more expensive, scientific books and pamphlets presented to and acquired by the National Museum Library, seventeen thousand dollars. (Approved March 3, 1901; Statutes, XXXI, 1187.)

#### BUREAU OF AMERICAN ETHNOLOGY.

For continuing ethnological researches among the American Indians, under the direction of the Smithsonian Institution, including salaries or compensation of all necessary employees and the purchase of necessary books and periodicals, fifty thousand dollars, of which sum not exceeding one thousand five hundred dollars may be used for rent of building. (Approved March 3, 1901; Statutes, XXXI, 1146.)

For payment of outstanding accounts for transportation incurred during the fiscal year eighteen hundred and ninety-seven under the appropriation "North American Ethnology, Smithsonian Institution," forty-seven dollars and sixty-one cents. (Approved March 3, 1901; Statute, XXXI, 1018.)

#### NATIONAL ZOOLOGICAL PARK.

For continuing the construction of roads, walks, bridges, water supply, sewerage, and drainage; and for grading, planting, and otherwise improving the grounds; erecting and repairing buildings and inclosures; care, subsistence, purchase, and transportation of animals; including salaries or compensation of all necessary employees; the purchase of necessary books and periodicals, the printing and publishing of operations, not exceeding one thousand five hundred copies, and general incidental expenses not otherwise provided for, eighty thousand dollars; one-half of which sum shall be paid from the revenues of the District of Columbia and the other half from the Treasury of the United States; and of the sum hereby appropriated five thousand dollars shall be used for continuing the entrance into the Zoological Park from Cathedral avenue and opening driveway into Zoological Park, including necessary grading and removal of earth. (Approved March 3, 1901; Statutes, XXXI, 1147.)

#### ASTROPHYSICAL OBSERVATORY.

For maintenance of Astrophysical Observatory, under the direction of the Smithsonian Institution, including salaries of assistants, the purchase of necessary books and periodicals, apparatus, printing and publishing results of researches, not exceeding one thousand five hundred copies, repairs and alterations of buildings, and miscellaneous expenses, twelve thousand dollars. That the Secretary of the Smithsonian Institution is directed to report to Congress on the first day of

the next regular session an entire account of all appropriations heretofore expended by the Astrophysical Observatory, what results have been reached, and what is the present condition of the work of said observatory. (Approved March 3, 1901; Statutes, XXXI, 1146.)

BIRDS AND EGGS FOR SCIENTIFIC PURPOSES.

AN ACT To amend an Act entitled "An Act for the protection of birds, preservation of game, and for the prevention of its sale during certain closed seasons, in the District of Columbia."

*Be it enacted by the Senate and House of Representatives of the United States of America in Congress assembled,*

\* \* \* \* \*

"SEC. 3. That for the purposes of this Act the following only shall be considered game birds: The Anatidæ, commonly known as swans, geese, brant, river and sea ducks; the Rallidæ, commonly known as rails, coots, mud hens, and gallinules; the Limicolæ, commonly known as shore birds, plovers, surf birds, snipe, woodcock, sandpipers, tattlers, and curlews; the Gallinæ, commonly known as wild turkeys, grouse, prairie chickens, pheasants, partridges, and quails; and the species of Icteridæ, commonly known as marsh blackbirds and reed birds or rice birds.

"That no person shall kill, catch, expose for sale, or have in his or her possession, living or dead, any wild bird other than a game bird, English sparrow, crow, Cooper's hawk, sharpshinned hawk, or great horned owl; nor rob the nest of any such wild bird of eggs or young; nor destroy such nest except in the clearing of land of trees or brush, under a penalty of five dollars for every such bird killed, caught, exposed for sale, or had in his or her possession, either dead or alive, and for each nest destroyed, and in default thereof to be imprisoned in the workhouse for a period not exceeding thirty days: *Provided*, That this section shall not apply to birds or eggs collected for scientific purposes under permits issued by the superintendent of police of the District of Columbia in accordance with such instructions as the Secretary of the Smithsonian Institution may prescribe, such permits to be in force for one year from date of issue and nontransferable." (Approved March 3, 1901; Statutes, XXXI, 1091.)

WORLD'S COLUMBIAN COMMISSION.

*Resolved by the Senate (the House of Representatives concurring),* That there be printed three thousand five hundred copies of so much of the report of the committee on awards of the World's Columbian Commission as is contained in the special reports upon special subjects or groups as were prepared by expert judges authorized to act by the World's Columbian Commission, its executive committee on awards,

the committee on final report, or the board of reference and control, of which one thousand shall be for the use of the Senate, two thousand for the use of the House of Representatives, and five hundred for distribution by the Department of State. (Passed Senate May 31, 1900; passed House March 1, 1901; Statutes, XXXI, concurrent resolutions, 14.)

## TENNESSEE CENTENNIAL EXPOSITION.

*Resolved by the Senate and House of Representatives of the United States of America in Congress assembled,* That so much as may be necessary of the unexpended balance of the appropriation of one hundred thousand dollars provided in section three of the Act to aid and encourage the holding of the Tennessee Centennial Exposition at Nashville in eighteen hundred and ninety-seven, approved December twenty-second, eighteen hundred and ninety-six, be applied to the preparation of illustrations and the printing and binding at the Government Printing Office of six thousand copies of the report of the board of management of the United States Government exhibit at said exposition, under the direction of the chairman of said board. (Approved, March 2, 1901; Statutes, XXXI, 1464.)

## LOUISIANA PURCHASE EXPOSITION.

AN ACT To provide for celebrating the one hundredth anniversary of the purchase of the Louisiana territory by the United States by holding an international exhibition of arts, industries, manufactures, and the products of the soil, mine, forest, and sea in the city of Saint Louis, in the State of Missouri.

Whereas it is fit and appropriate that the one hundredth anniversary of the purchase of the Louisiana territory be commemorated by an exhibition of the resources of the territory, their development, and of the progress of the civilization therein; and

Whereas such an exhibition should be of a national and international character, so that not only the people of that territory, but of our Union, and of all nations as well, can participate, and should therefore have the sanction of the Congress of the United States: Therefore,

*Be it enacted by the Senate and House of Representatives of the United States of America in Congress assembled,* That an exhibit of arts, industries, manufactures, and products of the soil, mine, forest, and sea shall be inaugurated in the year nineteen hundred and three, in the city of Saint Louis, in the State of Missouri, as herein provided.

SEC. 2. That a nonpartisan commission is hereby constituted, to consist of nine commissioners, to be known and designated as the "Louisiana Purchase Exposition Commission," who shall be appointed, within thirty days from the passage of this Act, by the President of the United States, and who shall also be subject to removal by him.

Vacancies in said commission to be filled in the same manner as original appointments.

SEC. 3. That the commissioners so appointed shall be called together by the Secretary of State of the United States, in the city of Saint Louis, by notice to the commissioners, as soon as convenient after the appointment of said commissioners, and within thirty days thereafter. The said commissioners, at said first meeting, shall organize by the election of their officers, and they may then, or thereafter, appoint such executive or other committees as may be deemed expedient, and a secretary at a salary of three thousand dollars per annum; that in addition to the salary of the secretary of said commission there is hereby allowed, out of any money appropriated to aid in carrying forward said exposition, the sum of ten thousand dollars per annum, or so much thereof as may be necessary, for the purpose of defraying the clerical, office, and other necessary expenses of said commission.

SEC. 4. That said commission, when fully organized under the provisions of this Act, shall appoint two of their number to act in conjunction with a like number appointed by the Louisiana Purchase Exposition Company, to constitute a board of arbitration, to whom all matters of difference arising between said commission and said company, concerning the administration, management, or general supervision of said exposition, including all matters of difference arising out of the power given by this Act to the said company or to the said national commission to modify or approve any act of the other of the two bodies, shall be referred for determination; and in the case of the failure of said board of arbitration to agree upon such matters as may be so referred, said board of arbitration shall appoint a fifth member thereof; and in case of the failure of the said board to agree upon a fifth member, such fifth member shall then be appointed by the Secretary of the Treasury. And the decision of said board shall be final in all matters presented to it for consideration and determination.

SEC. 5. That said commission be empowered, in its discretion, to accept, for the purposes of the exposition herein authorized, such site as may be selected and offered, and such plans and specifications of buildings for such purpose at the expense of and tendered by the corporation organized under the laws of the State of Missouri, known as "The Louisiana Purchase Exposition Company."

SEC. 6. That the allotment of space for exhibitors, classification of exhibits, plan and scope of the exposition, the appointment of all judges and examiners for the exposition, and the awarding of premiums, if any, shall all be done and performed by the said Louisiana Purchase Exposition Company, subject, however, to the approval of the commission created by section 2 of this Act; and said commission is hereby authorized to appoint a board of lady managers, of such number and to perform such duties as may be prescribed by said

commission, subject, however, to the approval of said company. Said board of lady managers may, in the discretion of said commission and corporation, appoint one member of all committees authorized to award prizes for such exhibits as may have been produced in whole or in part by female labor.

SEC. 7. That after the plans for said exposition shall be prepared by said company and approved by said commission the rules and regulations of said corporation governing rates for entrance and admission fees or otherwise affecting the rights, privileges, or interests of the exhibitors, or of the public, shall be fixed or established by said company, subject, however, to the modification or approval of said commission.

SEC. 8. That said commission shall provide for the dedication of the buildings of the Louisiana Purchase Exposition, in said city of Saint Louis, not later than the thirtieth day of April, nineteen hundred and three, with appropriate ceremonies, and thereafter said exposition shall be opened to visitors at such time as may be designated by said company, subject to the approval of said commission, not later than the first day of May, nineteen hundred and three, and shall be closed at such time as the national commission may determine, subject to the approval of said company, but not later than the first day of December thereafter.

SEC. 9. That whenever the President of the United States shall be notified by the national commission that provision has been made for grounds and buildings for the uses herein provided for, he shall be authorized to make proclamation of the same, through the Department of State, setting forth the time at which said exposition will be held, and the purpose thereof; and he shall communicate to the diplomatic representatives of foreign nations copies thereof, together with such regulations as may be adopted by the commission, for publication in their respective countries; and he shall, in behalf of the Government and the people, invite foreign nations to take part in the said exposition and to appoint representatives thereto.

SEC. 10. That all articles which shall be imported from foreign countries for the sole purpose of exhibition at said exposition, upon which there shall be a tariff or customs duty, shall be admitted free of payment of duty, customs fees, or charges, under such regulations as the Secretary of the Treasury shall prescribe; but it shall be lawful at any time during the exposition to sell, for delivery at the close thereof, any goods or property imported for and actually on exhibition in the exposition buildings or on the grounds, subject to such regulations for the security of the revenue and for the collection of import duties as the Secretary of the Treasury shall prescribe: *Provided*, That all such articles, when sold or withdrawn for consumption in the United States, shall be subject to the duty, if any, imposed upon such articles by the revenue laws in force at the date of importation, and

all penalties prescribed by law shall be applied and enforced against such articles and against the person who may be guilty of any illegal sale or withdrawal.

SEC. 11. That it shall be the duty of the national commission to make reports monthly to the President of the United States, showing receipts and disbursements and giving a general summary of the financial condition of said exposition, and a final report within six months after the close of the exposition, presenting the results and a full exhibit thereof.

SEC. 12. That the national commission hereby authorized shall cease to exist on the first day of January, nineteen hundred and five.

SEC. 13. That the United States shall not in any manner nor under any circumstances be liable for any of the acts, doings, proceedings, or representations of the said Louisiana Purchase Exposition Company, its officers, agents, or employees, or any of them, or for the service, salaries, labor, or wages of said officers, agents, servants, or employees, or any of them, or for any subscriptions to the capital stock, or for any certificates of stock, bonds, mortgages, or obligations of any kind issued by said corporation, or for any debts, liabilities, or expenses of any kind whatever attending such corporation or accruing by reason of the same.

SEC. 14. That there shall be exhibited at said exposition by the Government of the United States from its Executive Departments, the Smithsonian Institution, the National Museum, the United States Commission of Fish and Fisheries, and the Department of Labor, such articles and material as illustrate the function and administrative faculty of the Government in time of peace and its resources as a war power, tending to demonstrate the nature of our institutions and their adaptation to the wants of the people; and the Bureau of the American Republics is hereby invited to make an exhibit illustrating the resources and international relations of the American Republics, and space in the United States Government building shall be provided for the purpose of said exhibit; and to secure a complete and harmonious arrangement of such Government exhibit a board, to be known as the United States Government board, shall be created, independent of the commission hereinbefore provided, to be charged with the selection, purchase, preparation, transportation, arrangement, installation, safe-keeping, exhibition, and return of such articles and material as the heads of the several Executive Departments, the Secretary of the Smithsonian Institution, the Commissioner of Fish and Fisheries, the Commissioner of Labor, and the Director of the Bureau of the American Republics may, respectively, decide shall be embraced in said Government exhibit. The President may also designate additional articles for exhibition. Such board shall be composed of one person to be named by the head of each Executive Department, one by the Secretary of the Smithsonian Institution, one by the Commissioner of Fish and Fisheries, one by the

Commissioner of Labor, and one by the Director of the Bureau of American Republics. The President shall name one of said persons so detailed as chairman, and the board itself shall appoint its secretary, disbursing officer, and such other officers as it may deem necessary. The members of said board of management, with other officers and employees of the Government who may be detailed to assist them, including officers of the Army and Navy, shall receive no compensation in addition to their regular salaries, but they shall be allowed their actual and necessary traveling expenses, together with a per diem in lieu of subsistence, to be fixed by the Secretary of the Treasury, while necessarily absent from their homes engaged upon the business of the board. Officers of the Army and Navy shall receive this allowance in lieu of the transportation and mileage now allowed by law. Any provision of law which may prohibit the detail of persons in the employ of the United States to other service than that which they customarily perform shall not apply to persons detailed for duty in connection with the said Louisiana Purchase Exposition. Employees of the board not otherwise employed by the Government shall be entitled to such compensation as the board may determine. The disbursing officer shall give bond in the sum of thirty thousand dollars for the faithful performance of his duties, said bond to be approved by the Secretary of the Treasury. The Secretary of the Treasury shall advance to said officer from time to time, under such regulations as the Secretary of the Treasury may prescribe, a sum of money from the appropriation hereafter to be made for the Government exhibit, not exceeding at any one time the penalty of his bond, to enable him to pay the expenses of exhibit as authorized by the board of management herein created.

SEC. 15. That the Secretary of the Treasury is hereby authorized and directed to place on exhibition, in connection with the exhibit of his Department, upon such grounds as shall be allotted for the purpose, one of the life-saving stations authorized to be constructed on the coast of the United States by existing law, and to cause the same to be fully equipped with all apparatus, furniture, and appliances now in use in all life-saving stations in the United States.

SEC. 16. That the Secretary of the Treasury shall cause a suitable building or buildings to be erected on the site selected for the Louisiana Purchase Exposition for the Government exhibits, as provided in this Act, and he is hereby authorized and directed to contract therefor in the same manner and under the same regulations as for other public buildings of the United States; but the contracts for said building or buildings shall not exceed the sum of two hundred and fifty thousand dollars, which sum, or so much thereof as may be necessary, is hereby appropriated, out of any money in the Treasury not otherwise appropriated, to defray the expense of erecting said Government building or buildings hereby authorized. The Secretary of the Treasury shall

cause the said building or buildings to be constructed from plans to be approved by said Government board; and he is authorized and required to dispose of such building or buildings, or the material composing the same, at the close of the exposition, giving preference to the city of Saint Louis or to the said Louisiana Purchase Exposition Company to purchase the same at an appraised value, to be ascertained in such manner as he may determine.

SEC. 17. That the commissioners appointed by the President under the authority of this Act shall receive as compensation for their services and expenses the sum of five thousand dollars each per annum, the same to be paid by the Secretary of the Treasury and deducted from any money appropriated for said exposition.

SEC. 18. That no member of said commission or of said Government board, whether an officer or otherwise, shall be personally liable for any debt or obligation which may be created or incurred by the said commission or by the said United States Government board herein authorized.

SEC. 19. That whereas the Secretary of the Treasury has certified, under date of February sixth, nineteen hundred and one, that the Louisiana Purchase Exposition Company has presented to him proof to his satisfaction that it has raised ten million dollars for and on account of inaugurating and carrying forward an exposition at the city of Saint Louis, Missouri, in the year nineteen hundred and three, to celebrate the one hundredth anniversary of the purchase of the Louisiana Territory; therefore there is hereby appropriated, out of any money in the Treasury not otherwise appropriated, the sum of five million dollars, to aid in carrying forward such exposition, to pay the salaries of the members and secretary of the national Commission herein authorized, and such other necessary expenses as may be incurred by said commission in the discharge of its duties in connection with said exposition, and to discharge all other obligations incurred by the Government on account of said exposition, except for the erection of its own buildings and the making and care of its own exhibits at said exposition. That the money hereby appropriated shall be disbursed under the direction of the said Louisiana Purchase Exposition Company under rules and regulations to be prescribed by the Secretary of the Treasury and upon vouchers to be approved by him: *Provided*, That, except for the payment of the salaries and expenses of the national commission, no part of said appropriation shall become available until the sum of ten million dollars shall have been expended by said company on account of said exposition to the satisfaction of the Secretary of the Treasury: *Provided further*, That all sums expended by the Government on account of said exposition, including the salaries and expenses of said national commission, except for the erection of its own buildings and the making and care of its own



exhibits at said exposition, shall be limited to and paid out of the appropriation of five million dollars herein provided for such purpose.

SEC. 20. That there shall be repaid into the Treasury of the United States the same proportionate amount of the aid given by the United States as shall be repaid to either the Louisiana Purchase Exposition Company or the city of Saint Louis: *Provided*, That this section shall not be taken or construed to give the United States a right to share in the proceeds of said exposition beyond the actual amount appropriated to aid in carrying forward said exposition.

SEC. 21. That any bank or trust company located in the city of Saint Louis, or State of Missouri, may be designated by the Louisiana Purchase Exposition Company to conduct a banking office upon the exposition grounds, and if the bank so designated shall be a national bank, upon such designation being approved by the Comptroller of the Currency, said national bank is hereby authorized to open and conduct such office as a branch of the bank, subject to the same restrictions and having the same rights as the bank to which it belongs: *Provided*, That the branch office authorized hereby, if the same shall be a branch of a national bank, shall not be operated for a period longer than two years, beginning not earlier than July first, nineteen hundred and two, and closing not later than July first, nineteen hundred and four.

SEC. 22. That no citizen of any foreign country shall be held liable for the infringement of any patent granted by the United States, or of any trade-mark or label registered in the United States, where the act complained of is or shall be performed in connection with the exhibition of any article or thing at the Louisiana Purchase Exposition.

SEC. 23. That the Secretary of War be, and he hereby is authorized, at his discretion, to detail for special duty, in connection with the Louisiana Purchase Exposition, such officers of the Army as may be required, to report to the general commanding the Department of Missouri; and the officers thus detailed shall not be subject to loss of pay or rank on account of such detail, nor shall any officer or employee of the United States receive additional pay or compensation because of services connected with the said exposition from the United States or from said exposition.

SEC. 24. That nothing in this Act shall be so construed as to create any liability of the United States, direct or indirect, for any debt or obligation incurred, nor for any claim for aid or pecuniary assistance from Congress or the Treasury of the United States in support or liquidation of any debts or obligations created by said commission.

SEC. 25. That as a condition precedent to the payment of this appropriation the directors shall contract to close the gates to visitors on Sundays during the whole duration of the fair. (Approved March 3, 1901; Statutes XXXI, 1440.)



REPORT  
OF  
S. P. LANGLEY,  
SECRETARY OF THE SMITHSONIAN INSTITUTION,  
FOR THE YEAR ENDING JUNE 30, 1901.

---

*To the Board of Regents of the Smithsonian Institution.*

GENTLEMEN: I have the honor to present herewith my report showing the operations of the Institution during the year ending June 30, 1901, including the work placed under its direction by Congress, in the United States National Museum, the Bureau of American Ethnology, the International Exchanges, the National Zoological Park, and the Astrophysical Observatory.

Following the precedent of several years, I have given, in the body of this report, a general account of the affairs of the Institution and its bureaus, while the appendix presents more detailed statements by the persons in direct charge of the different branches of the work. Independently of this, the operations of the National Museum are fully treated in a separate volume of the Smithsonian Report, and the Report of the Bureau of American Ethnology constitutes a volume prepared under the supervision of the Director of that Bureau.

THE SMITHSONIAN INSTITUTION.

THE ESTABLISHMENT.

By act of Congress approved August 10, 1846, the Smithsonian Institution was created an Establishment. Its statutory members are the President, the Vice-President, the Chief Justice of the United States, and the heads of the Executive Departments. The prerogative of the Establishment is "the

supervision of the affairs of the Institution and the advice and instruction of the Board of Regents."

On March 4, 1901, the vacancy in the membership of the Establishment which had existed since the death of Vice-President Hobart, on November 21, 1899, was filled by the election of the Hon. Theodore Roosevelt to the Vice-Presidency. The Hon. John W. Griggs resigned as Attorney-General and was succeeded by the Hon. P. C. Knox.

As organized on June 30, the Establishment consisted of the following ex-officio members:

- WILLIAM MCKINLEY, *President of the United States.*  
 THEODORE ROOSEVELT, *Vice-President of the United States.*  
 MELVILLE W. FULLER, *Chief Justice of the United States.*  
 JOHN HAY, *Secretary of State.*  
 LYMAN J. GAGE, *Secretary of the Treasury.*  
 ELIHU ROOT, *Secretary of War.*  
 PHILANDER C. KNOX, *Attorney-General.*  
 CHARLES EMORY SMITH, *Postmaster-General.*  
 JOHN D. LONG, *Secretary of the Navy.*  
 ETHAN ALLEN HITCHCOCK, *Secretary of the Interior.*  
 JAMES WILSON, *Secretary of Agriculture.*

#### BOARD OF REGENTS.

The Board consists of the Vice-President and the Chief Justice of the United States as ex-officio members, three members of the Senate, three members of the House of Representatives, and six citizens, "two of whom shall be residents of the city of Washington and the other four shall be inhabitants of some State, but no two of them of the same State."

In accordance with a resolution of the Board of Regents adopted January, 1890, by which its annual meeting occurs on the fourth Wednesday of each year, the Board met on January 23, 1901, at 10 o'clock a. m.

The following is an abstract of its proceedings, which will be found in detail in the annual report of the Board to Congress:

The Secretary announced the death on October 17, 1900, of Dr. William Lyne Wilson, and said that he could not refrain

from expressing his own personal sense of loss at the removal of one whose broad scholarship and large experience in public affairs were joined to a disposition which made him at once the most valued and sympathetic of counselors. The Hon. J. B. Henderson, chairman of the Executive Committee, also made some personal references to Mr. Wilson, which together with the action of the Board in his memory will be found under the head of "Necrology."

The vacancy in the Board caused by the death of Mr. Wilson was filled by the appointment of the Hon. George Gray through a resolution of Congress approved January 14, 1901.

The Secretary presented his report of the operations of the Institution for the fiscal year ending June 30, 1900, calling especial attention to the subject of the Exchanges, in whose behalf he had visited England, France, and Germany, and had endeavored to secure better arrangements with those countries, and he hoped that from France and perhaps from Germany fuller returns might be expected.

He also spoke of the Zoological Park and his desire that the Government would place in that city of refuge for the vanishing animal races of the North American continent, some specimens of the giant animals of Alaska.

Mr. Hitt here brought to the attention of the Board the oration which had been delivered upon the occasion of the conferring of the degree of Doctor of Science upon the Secretary by the University of Cambridge, England, which Mr. Henderson, whom the Regents "knew to be a scholar who loved the tasks of scholarship, had translated into such English as Horace would have used if he had to speak in that tongue." It was ordered that the address of the public orator and the translation by Mr. Henderson be placed upon the record.

After the adoption of the reports of the executive and permanent committees which had been presented by Mr. Bell in the absence of their chairman, Senator Henderson, attention was called to the fact that a vacancy existed in the executive committee, caused by the death of Dr. Wilson, and upon resolution, the Hon. R. R. Hitt was elected to fill this vacancy.

The Royal Prussian Academy of Sciences having invited the Institution to participate in the celebration of the two hundredth anniversary of its foundation, on the 19th and 20th of

March, 1900, the Hon. Andrew D. White, United States Ambassador at Berlin and a member of the Board, was requested to represent the Institution on this noteworthy occasion. A suitably engrossed address was transmitted through the Department of State and presented by Dr. White to the Prussian Academy, the acknowledgment of which, together with an interesting letter from Dr. White describing the ceremonies, were laid before the Board. Dr. White described the exercises as having been of exceptional interest. They took place in the Royal Palace, where the Emperor received the entire body of guests in state, surrounded by the high functionaries of the Empire bearing the royal insignia, while the Monarch on the throne delivered an address of welcome. Later there were entertainments in honor of the delegates, not only by the King, but by the Chancellor of the Empire and others. On the second day there occurred a general reception in the great hall of the Prussian legislature, which was also very impressive.

The Secretary added that Dr. White had further said in conversation that in all his experience as a minister to European courts he had never seen so imposing a display of ceremonial magnificence.

Under unfinished business there came up the resolution introduced by Dr. Bell with reference to the utilization of scientific bureaus of the Government for purposes of research. The resolution in the form it had been offered at the previous meeting was withdrawn by Dr. Bell and the following, which contained some alterations intended to meet the views of other members of the executive committee, was presented:

In order to facilitate the utilization of the Government Departments for the purposes of research—in extension of the policy enunciated by Congress in the joint resolution approved April 12, 1892:

*Resolved*, That it is the sense of the Board that it is desirable that Congress extend this resolution so as to afford facilities for study to all properly qualified students or graduates of universities, other than those mentioned in the resolution, and provide for the appointment of an officer whose duty it shall be to ascertain and make known what facilities for research exist in the Government Departments, and arrange with the heads of the Departments, and with the officers in charge of Government collections, on terms satisfactory to them, rules and regulations under which suitably qualified

persons may have access to these collections for the purpose of research with due regard to the needs and requirements of the work of the Government; and that it shall also be his duty to direct, in a manner satisfactory to the heads of such Departments and officers in charge, the researches of such persons into lines which will promote the interests of the Government and the development of the natural resources, agriculture, manufactures, and commerce of the country, and (generally) promote the progress of science and the useful arts, and the increase and diffusion of knowledge among men.

After some discussion by the Regents, on motion the resolution was adopted.

The Secretary also brought to the attention of the Board a letter received from Genoa indicating the necessity of removing the remains of James Smithson, interred in the British burial ground at Genoa, to a new cemetery which was to be chosen later on, and requesting to be informed of the wishes of the Regents. After some discussion, in which the desirability of bringing the remains to this country was adversely considered, the following resolution was adopted:

*Resolved.* In view of the proposed abolition of the English cemetery at Genoa, which contains the remains of James Smithson, that the Secretary be requested to arrange either with the English church or with the authorities of the National Burying Ground at Genoa for the reinterment of Smithson's remains, and the transfer of the original monument.

The Secretary then made his customary statement to the Board, remarking that, in view of the lateness of the hour, he would pass over some of the matters about which he had intended to speak, and among others about the continuation of his experiments in aërodromics and the results of the eclipse expedition of May, 1900, which had since been made public. The observation of the eclipse had left one or two interesting but unsettled questions, and he had determined to send out a small expedition to Sumatra on the occasion of the exceptionally important eclipse of the sun in May, 1901.

He brought to the attention of the Board the proposed expedition to Babylonia under Dr. Edgar James Banks, who had gone to Constantinople in the hope of securing permission to excavate the town of Mugheir, which, according to tradition, is the site of the Ur of the Chaldees from which Abraham came. The material results of such expedition, if any,

which under Turkish law might be allowed to leave the country, would be deposited in the Institution.

He also reviewed briefly the greatly improved condition of the Smithsonian Deposit in the Library of Congress since the new quarters had been erected, calling attention to the fact that a sum of not less than \$50,000 would probably be required to supply the defects in this Deposit due to the lack of adequate provision for it by Congress during the past twenty years, and to fill in the important sets of periodicals which can not be secured by exchange.

He reminded the Regents, in connection with the projected International Catalogue of Scientific Literature, that the first step to such a catalogue had been taken many years since by Professor Henry, that the support of the catalogue by private universities and libraries in this country had been prompt and gratifying, and that there remained but the supplying of the material for the United States, for which he hoped Congress would provide, and while waiting its action for carrying on the work in the interim, he had made a strictly temporary provision with the aid of the funds of the Institution. It was not intended by him to recommend any permanent contribution from the Institution's limited funds.

The Secretary then made a statement with regard to the Museum and its needs, announcing that he had recently arranged that the Assistant Secretary should give his personal attention chiefly to the Museum; that he believed that the Committee on Appropriations was getting to see the inevitable necessity of enlarging the Museum buildings, that with this would come larger responsibilities, and that this growth and the confidence of the community and of the Congress were due in a large measure to their belief in that impartial rule of the Regents which has in the past guaranteed consideration and fairness in the selection of Museum officers and stability in its policy.

Finally, the Secretary called attention to the fact that the continued independence and usefulness of the Institution would depend in a large measure upon the increase in its endowment. When the Institution was established over fifty years ago, its fund of \$600,000 was relatively a large one, twice as large as that of Yale College, larger than that of Princeton, Columbia, and the University of Pennsylvania, and only equaled by the fund of Harvard. The Institution's endowment has in the



fifty years increased but from \$600,000 to somewhat less than \$1,000,000, but the *average* endowment of the five universities named is now about \$8,000,000, indicating that in this regard the Institution's fund for scientific purposes is relatively unimportant compared with what it was fifty years ago.

The Secretary announced to the Regents the fact that several new bequests had been made to the Institution, though none of these were realized at present. While the Institution has scrupulously refrained from even the appearance of soliciting funds, yet he felt that its own utility depended largely upon the increase of the means which were directly at the disposition of the Regents. He asked for any instructions as to the employment of means consonant with the position and actual independence of the Institution for making its fitness as a conservator and administrator of gifts and legacies known to the general public, and he spoke of the desirability of a wider circulation of the Secretary's report and Appendix, to which he had given of late much personal care. A discussion upon the subject arose, but the Board adjourned without taking any action.

#### APPOINTMENT OF REGENTS.

The Hon. Shelby M. Cullom, whose term of office as Regent expired March 4, 1901, was on March 7 reappointed by the President of the Senate, and the Hon. Francis M. Cockrell, Senator from Missouri, was appointed to succeed the Hon. William Lindsay, whose term as United States Senator expired on March 4, 1901.

As organized at the end of the fiscal year, the Board of Regents consisted of the following members:

The Hon. M. W. Fuller, Chief Justice of the United States, Chancellor; the Hon. Theodore Roosevelt, Vice-President of the United States; Senator S. M. Cullom; Senator O. H. Platt; Senator Francis M. Cockrell; Representative R. R. Hitt; Representative Robert Adams, jr.; Representative Hugh A. Dinsmore; Dr. James B. Angell; Dr. Andrew D. White; the Hon. J. B. Henderson; the Hon. George Gray; Dr. A. Graham Bell; the Hon. Richard Olney.

#### ADMINISTRATION.

The Secretary's time continues to be chiefly given to purely administrative duties, while, during such increasingly limited

opportunity as presents itself consistently with these, he endeavors not only to oversee its scientific investigations but to give his personal care to them. His purpose has always been, in regard to the former, to put upon those in immediate charge of the bureaus of the Institution all the authority that is consistent with his own responsibility to the Board of Regents. He has already mentioned that the growth of those bureaus has thrown upon the Institution a very considerable amount of clerical labor pertaining to Government work, so that the limited income of the Institution is drawn upon for matters which should properly be provided for by Congress.

The Board has authorized the Secretary to lay these matters before Congress, but the needs of other parts of the Institution's service have seemed so pressing that he has as yet deferred doing so in favor of such other demands.

#### BUILDINGS.

The renovation and rearrangement of storage rooms in the south tower was continued during the year, and in the basement additional space was arranged for the use of the international exchanges. Work was also begun toward the construction of a tunnel between the Smithsonian and Museum buildings for carrying steam pipes, with the intention of centralizing the heating apparatus and utilizing new Museum boilers for heating both buildings. Improvements in the Museum building and in the buildings at the Zoological Park are mentioned elsewhere.

#### FINANCES.

The permanent funds of the institution are as follows:

Bequest of Smithson, 1846.....	\$515, 169. 00
Residuary legacy of Smithson, 1867 .....	26, 210. 63
Deposits from savings of income, 1867.....	108, 620. 37
Bequest of James Hamilton, 1875 .....	\$1, 000
Accumulated interest on Hamilton fund, 1895.....	1, 000
	2, 000. 00
Bequest of Simeon Habel, 1880.....	500. 00
Deposits from proceeds of sale of bonds, 1881.....	51, 500. 00
Gift of Thomas G. Hodgkins, 1891 .....	200, 000. 00
Portion of residuary legacy of Thomas G. Hodgkins, 1894....	8, 000. 00
	912, 000. 00
Total permanent fund.....	912, 000. 00

In addition to the above permanent fund, the Regents hold certain approved railroad bonds which form part of the fund established by Mr. Hodgkins for investigations into the properties of atmospheric air.

The act organizing the Institution (sec. 5591, U. S. Revised Statutes) was amended by act of Congress approved March 12, 1894, as follows:

The Secretary of the Treasury is authorized and directed to receive into the Treasury on the same terms as the original bequest of James Smithson such sums as the Regents may, from time to time, see fit to deposit; not exceeding with the original bequest the sum of one million dollars: *Provided*, That this shall not operate as a limitation on the power of the Smithsonian Institution to receive money or other property by gift, bequest, or devise, and to hold and dispose of the same in promotion of the purposes thereof.

Under this provision the permanent fund of \$912,000 is deposited in the Treasury of the United States, and bears interest at 6 per cent per annum. The interest alone is employed in carrying out the aims of the institution.

The unexpended balance at the beginning of the fiscal year, July 1, 1900, as stated in my last report, was \$76,219.07. The total receipts by the Institution during the year were \$66,829.39. Of this sum \$56,400 was derived from interest, while the remaining \$10,429.39 was received from miscellaneous sources.

The amount disbursed during the year was \$59,085.20, the details of which are given in the report of the executive committee. The balance remaining to the credit of the Secretary on June 30, 1901, for the expenses of the Institution was \$83,963.26, which includes the \$10,000 specifically referred to in previous reports, as well as the interest accumulated on the Hodgkins and other funds, which is held against certain contingent obligations, besides relatively considerable sums held to meet liabilities which may be expected to mature as a result of various scientific investigations and publications in progress.

During the fiscal year of 1901 Congress charged the Institution with the disbursement of the following appropriations:

International Exchanges, Smithsonian Institution.....	\$24, 000
American Ethnology, Smithsonian Institution .....	50, 000
Astrophysical Observatory, Smithsonian Institution .....	\$12, 000
Observation of eclipse of the sun, May 28, 1900.....	4, 000
	<hr style="width: 10%; margin-left: auto; margin-right: 0;"/> 16, 000

## United States National Museum:

Furniture and fixtures .....	\$17, 500
Heating and lighting .....	17, 500
Preservation of collections.....	180, 000
Purchase of specimens .....	10, 000
Postage .....	500
Books .....	2, 000
Rent of workshops .....	4, 040
Repairs to buildings .....	15, 000
Printing .....	17, 000

---

 \$263, 540

 National Zoological Park..... 

---

 75, 000

---

 428, 540

All the vouchers for disbursements made during the fiscal year have been examined by the executive committee, and a detailed statement of the receipts and expenditures will be found reported to Congress in accordance with the provisions of the sundry civil acts of October 2, 1888, August 5, 1892, and March 3, 1899, in a letter addressed to the Speaker of the House of Representatives.

The vouchers for all the expenditures from the Smithsonian fund proper have likewise been examined and their correctness certified to by the executive committee, whose statement will be published, together with the accounts of the funds appropriated by Congress, in the report of that committee.

For carrying on the Government's interests under the charge of the Smithsonian Institution for the fiscal year ending June 30, 1902, estimates were forwarded as usual to the Secretary of the Treasury. The following table shows the estimates submitted and the sums respectively appropriated:

	Estimates.	Appropriations.
International Exchanges.....	\$24, 000	\$24, 000
American Ethnology .....	60, 000	50, 000
Astrophysical Observatory .....	15, 000	12, 000
National Museum:		
Furniture and fixtures .....	20, 000	20, 000
Heating and lighting .....	23, 000	23, 000
New boilers .....	12, 500	12, 500
Preservation of collections.....	180, 000	180, 000
Purchase of specimens .....	25, 000	10, 000
Books .....	2, 000	2, 000
Repairs to buildings.....	19, 500	15, 000
Galleries .....	2, 500	5, 000
Rent of workshops .....	4, 040	4, 400
Postage.....	500	500
Printing .....	17, 000	17, 000
National Zoological Park .....	120, 000	80, 000

## RESEARCH.

It was a part of the original plan of the Institution that its Secretary should not give his time wholly to administrative duties, but should, as a student of nature, directly aid in its scientific investigations.<sup>1</sup>

Research work in various fields of science has been continued by the Institution and its dependencies. The Secretary has made some progress toward the solution of the problem of mechanical flight, and in the Astrophysical Observatory has continued work believed to be important, which is described later.

Through the Museum and the Bureau of American Ethnology the Institution has been enabled to carry on various biological and ethnological researches which will be found fully described elsewhere in this report and need not be repeated here.

## HODGKINS FUND.

Among the many applications for grants from the Hodgkins fund, it has been found practicable to approve several which conform to the conditions of the bequest, and investigations in various lines of original research are making satisfactory advances as mentioned below.

In November, 1900, a grant was approved on behalf of Prof. Wallace C. Sabine, of Harvard University, for the aid of his investigations on sound, the particular phase of the problem under investigation being the subject of loudness and interference. This research requires apparatus of special design, part of which is now complete and is satisfactory.

Professor Sabine, who had charge of the design of the new symphony hall in Boston, has for several years given much attention to the problem of architectural acoustics, or the science of sound as applied to buildings. It is expected that his complete report will be of much practical interest in connection with this subject.

In December, 1900, Mr. C. Canovetti, chief engineer of the city of Brescia, Italy, made an application for a Hodgkins

---

<sup>1</sup> *Resolved*, That the Secretary continue his researches in physical science, and present such facts and principles as may be developed, for publication in the Smithsonian Contributions. (Adopted at meeting of the Board of Regents January 26, 1847.)

grant, at the same time bringing to my attention his experiments which have been awarded prizes by the Société d'Encouragement pour l'Industrie Nationale, of Paris, and by the Reale Academia dei Lincei, of Rome.

As is customary, the application received the consideration of specialists in the branch of atmospheric research pursued by Mr. Canovetti, and after the acceptance by him of the conditions set forth in the Hodgkins circular, a moderate grant was approved on his behalf in April, 1901, for experiments now in progress, which will be reported on later.

Details of the progress to date of the research mentioned in my last report as conducted by Dr. Victor Schumann, of Leipzig, have been received. The most noteworthy points in the results so far refer, perhaps, to the relation of light and electricity and to the probable insight into the nature of the Roentgen rays to be gained in the course of this investigation. The interest in this subject, in both popular and scientific circles, is now so widespread that permission has been given to Dr. Schumann to announce independently in some journal in his own country the discoveries made in the progress of his research, reporting them at the same time to the Institution. It is felt that this course will subserve the cause of science by satisfying the immediate and general interest in this subject, and that it will also justly tend to establish Dr. Schumann's right of priority in his own researches.

The investigations of Dr. von Lendenfeld, of the University of Prague, are still in progress, and it is anticipated that his final report, which is now awaited, may furnish data available for greatly improving the construction of the meteorological kites now in constant use, and thus be the means of adding materially to our knowledge of atmospheric conditions at high altitudes, the practical application of which is of such general interest and usefulness.

The interesting experiments in connection with kites and with air currents at varying altitudes, which have been prosecuted for some time at the Blue Hill Meteorological Observatory by Mr. A. Lawrence Rotch, are still in progress, an additional grant having been approved this year on behalf of Mr. Rotch.

It will be remembered that the original grant mentioned in my report for 1897 was made for the purpose of securing

automatic kite records at a height of over 10,000 feet, an altitude which so lately as four years ago had never been attained. Successive grants have since been made, and while it is due to the persistence and skill of Mr. Rotch and his assistants that his own extraordinary record of 14,000 feet has been surpassed by him, it is a matter of gratification that the Hodgkins fund of the Institution has in some way been associated with such results.

Dr. Carl Barus, of Brown University, whose research on ionized air, mentioned in my last report as having been aided by a grant from the Hodgkins fund, has during the progress of his investigation frequently summarized his provisional results for the Institution. As in other cases, because of the immediate interest attaching to this investigation, Dr. Barus has been authorized to publish preliminary reports of his progress in the scientific journals. In April, 1901, this research was completed and reported upon in detail to the Institution so far as concerned the discussion of data accumulated since the approval of the Hodgkins grant. This completed report is now in course of publication in the *Smithsonian Contributions to Knowledge*.

This research on atmospheric conditions, in investigating the production of nuclei, determining their number per cubic centimeter, their velocity, their association with ionization, the effect of the presence of the electric field, etc., proves interesting not only in its own methods and results, but because of its agreement with the data obtained by other investigators from different experiments and theoretically different points of view.

The research of Prof. Louis Bevier, of Rutgers College, in connection with the analysis of vowel sounds is steadily progressing. During the year detailed studies of several vowel sounds have been made with results which agree well with the conclusions arrived at through an entirely different method by von Helmholtz in his analysis of German vowels.

The lower resonance detected in our vowel sounds by Dr. Bevier, and not recorded by von Helmholtz save for "a," will later be the subject of detailed discussion which will endeavor to establish and explain these facts. A further report upon this research is awaited with interest.

In December, 1900, a grant was approved on behalf of Dr.

Marey, of the French Institute, in aid of his experiments on air currents. This research has been materially furthered by the successful application of chronophotography, a field in which Dr. Marey's experiments have heretofore been noteworthy. By this means it has not only been possible to analyze the movements of waves and currents of liquids which are invisible to the naked eye, but even the displacements of molecules.

From reports so far submitted, but as yet necessarily incomplete, it is believed that this research will aid materially in the solution of various problems connected with the mechanics of propulsion in fluids, at the same time rendering service in solving practical questions of ventilation, etc. The illustration indicating the method of making visible the course of these otherwise invisible currents round an obstacle is appended.

The reader, if he has not noticed the rare experiment of successful machine flight of heavy bodies through the air, has probably had his attention called at times to the extraordinary difference between the performance of small steam vessels like yachts or tugs, where with equal power one glides through the water almost as though it offered no resistance, while another labors in rolling a formidable wave before it. The same differences occur in still more subtle form in the air. We can not with the naked eye separately see, in either case, the currents that produce the effect, but by Dr. Marey's most ingenious experiments we are enabled to obtain photographic records from which we can study the forms which offer the least resistance and see why it is. A single illustration, indicating the influence of a very slight divergence from the best forms in the case of the air, is here given.

The experiments of Prof. A. G. Webster, of Clark University, on the propagation, reflection, and diffraction of sound have achieved a result of practical value in the construction of an instrument capable of emitting an accurately measured sound. It is thus possible, in treating persons of defective hearing, to decide with exactness as to the degree of deafness in a subject, and to say if the power of hearing varies at different times. An instrument which furnishes the means of accurately determining these points should prove of value in medical treatment.



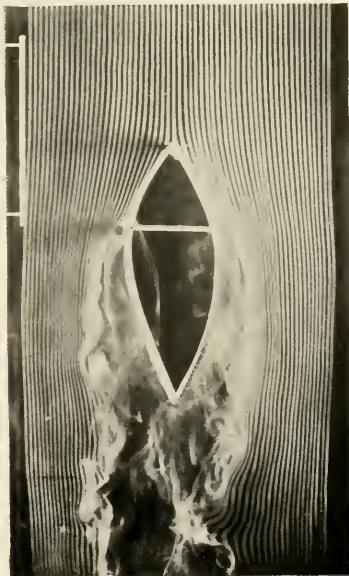
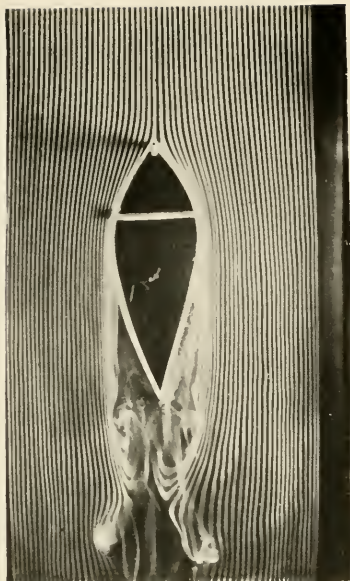

AIR CURRENTS PASSING CURVED  
OBJECT.



A preliminary report has been received from Prof. William Hallock, of Columbia University, New York, who, as before stated, is conducting a research on the motion of a particle of air under the influence of articulate sound. General investigations allied to this subject, which are carried on in the laboratory of Columbia University, although in no way aided by the Hodgkins fund, have contributed helpfully to a knowledge of the principles underlying these experiments, and especially to certain parts of the investigation referring to the relation between the amplitude of vibration of an air particle and the amplitude of vibration of a film, or dust particle, suspended in the air. Dr. Hallock's research will be continued during the present year, when a final report is expected.

A third grant has been approved on behalf of the Journal of Terrestrial Magnetism and Atmospheric Electricity, the editor, as in the two previous years, sending to educational establishments a specified number of copies of the Journal, in accordance with a list approved by the Institution.

The conditions requisite to the approval of a grant from the Hodgkins fund, and to which applicants give assent before final action, are stated in the Hodgkins circular, a copy of which was included in the report of last year. It may, however, be here repeated that should an investigation be of considerable duration, a summary of progress is to be submitted to the Institution at the end of six months, as well as a subsequent report recording the final results of a research.

These researches are, in the words of Mr. Hodgkins, all devoted to the "increase and diffusion" of more "exact knowledge in regard to the nature and properties of atmospheric air in connection with the welfare of man," and are aided by the Hodgkins fund, it is hoped, in a manner which their promoter intended when he made his gift to the Institution in the above words.

#### NAPLES TABLE.

Realizing that the opportunity for study in the Naples Zoological Station is an especial advantage to students prepared to do original work in embryological, histological, or other fields, the Institution is desirous of granting the privilege of the Smithsonian Table to all applicants so qualified, and with this end in view the conditions, which are here

rehearsed, have been made such as can be easily complied with. The appointing power rests finally with the Secretary, but each request for the seat with its accompanying data is referred as a preliminary step to the Advisory Committee for recommendation, and this year, as heretofore, he has been indebted to the committee for valuable suggestions in this connection and has been very usually guided by their advice.

With a formal application for the table, addressed to the Secretary of the Institution, a summary of the scientific history of the candidate is to be submitted, together with such letters of recommendation as he may wish to place on record. These credentials should contain a list of the original papers which have been published by the applicant, and should be accompanied by any data which would tend to establish a capability for original research, such as conducted by those resident at the station. By an official decision, arrived at in the interest of all candidates, the table is not assigned more than six months in advance of the date for which it is desired, and no appointment is made for a longer period than six months, although a student may apply for an extension of time or for future reappointment. Few investigators have so far desired to remain longer than six consecutive months at the station, although a second appointment is at times requested, and applications are not infrequently submitted several months in advance of the period when it is in order to take them up for consideration.

It should be again noted that Smithsonian appointees are expected to report to the Institution at the termination of their term of occupancy, or preferably at the end of each three months, in case of a longer residence at the station.

The following appointments to the Smithsonian seat have been made during the year:

Dr. P. C. Mensch, of Ursinus College, Collegeville, Pa., whose application was approved during the summer of 1900, occupied the Smithsonian Table during November of the same year.

Dr. F. L. Stevens, of the University of Chicago, was appointed for May, 1901.

Dr. Burton-Opitz, of Rush College and the University of Chicago, and later "Voluntär-Assistent" to Dr. Hürthle in the

physiological institute of the Royal University of Breslau, received the appointment for three months during the summer of 1901.

Applications for the coming year are now receiving consideration.

An extract from an open letter issued by Doctor Dohrn, the experienced and always considerate Superintendent of the Station, of interest to the newcomer in Naples, is given in a footnote. The student who has been authorized to occupy the Smithsonian Table at the Station will do well to address the Institution for fuller information which, for lack of space, is not here given.<sup>1</sup>

<sup>1</sup> Notre longue expérience nous met à même de donner aux personnes qui désirent se rendre pour la première fois à la Station Zoologique quelques conseils qui leur feront épargner du temps et de l'argent.

1. *Choix du matériel d'étude.*—Veuillez informer le plus exactement que vous pourrez l'Administration de la Station Zoologique, "Stazione zoologica, Napoli," du jour de votre arrivée et de ce que vous désirez étudier, afin que nous puissions préparer d'avance, si cela est nécessaire et possible, le matériel dont vous aurez besoin. Il serait avantageux pour vous d'indiquer en même temps d'autres objets que vous auriez l'intention d'étudier pour le cas où le matériel viendrait à manquer temporairement. Si vous voulez vous occuper d'embryologie nous vous recommandons de consulter pour votre gouverne les renseignements que nous avons publiés<sup>1</sup> sur la ponte des œufs, etc.

2. *Outillage.*—Vous trouverez plus loin la liste détaillée de ce que nous pourrions vous fournir en fait d'ustensiles, de réactifs, etc. Nous vous prions de bien vouloir en tenir compte en faisant vos malles. Nous vous conseillons de porter votre microscope avec vous, comme petit bagage, et de ne pas le placer dans vos malles; évitez surtout de l'expédier comme colis, car souvent même l'emballage le plus soigneux n'empêche pas les accidents. Ayez les mêmes précautions à l'égard de votre microtome. Lorsque les colis sont expédiés par chemin de fer il faut de quatre à six semaines pour les colis ordinaires, de deux à trois pour ceux par grande vitesse. Les instruments et les livres peuvent plus facilement entrer en franchise s'ils sont emballés avec des vêtements déjà portés. Il faudra toujours s'abstenir de mettre des cigares ou du tabac dans les colis ordinaires ou dans ceux par grande vitesse. Comme adresse il suffira que vous écriviez votre nom suivi de "Stazione Zoologica, Napoli." Ce sera aussi la meilleure adresse pour vos lettres, etc. \* \* \*

(b) *Matériel d'étude.*—M. Lo Bianco ira s'informer régulièrement de vos

<sup>1</sup> Mitth. Z. Stat. Neapel, 1. Bd., 1879, p. 119 et suiv., 124 et suiv.; 2. Bd., 1881, p. 162 et suiv.; 8. Bd., 1888, p. 385 et suiv.

## EXPLORATIONS.

The Institution has continued to carry on various astronomical, biological, and ethnological explorations through the medium of the Astrophysical Observatory, the National Museum, and the Bureau of American Ethnology, and has also cooperated with the Executive Departments in these directions. The details of most of these explorations are given in the paragraphs devoted to the several bureaus.

During the past summer the Secretary, in a journey undertaken at his private charges in search of rest, departed considerably from the beaten route of travel by making a voyage to the South Pacific Ocean, where he visited the island of Tahiti and was there particularly fortunate in witnessing the celebrated "fire-walk" ceremony which he has described in an article in the general appendix to this report.

## PUBLICATIONS.

The publications of the Institution represent the double aim of its founder, that it should exist for (1) the "increase" and (2) the "diffusion" of knowledge.

---

désirs et vous fera porter dès le lendemain à votre place les animaux et les plantes les plus communes, en tant que possible. Il est fait exception pour les dimanches et les jours de fête. Il faudra bien se rappeler que le matériel que nous fournissons est destiné exclusivement aux recherches et non pas à la formation de collections étrangères à vos études. \* \* \*

(c) La bibliothèque est ouverte aux mêmes heures que les laboratoires, mais on la ferme à la tombée du jour.

Si vous voulez emporter un livre relié de la bibliothèque à votre place de travail, vous n'aurez qu'à mettre à sa place un carton portant le numéro qui vous est échu. On mettra à votre disposition douze de ces cartons dans la bibliothèque d'en bas et six dans celle d'en haut.

Pour avoir les livres non reliés vous remettrez un reçu au bibliothécaire. Les journaux et les brochures qui se trouvent sur les tables de lecture ne pourront pas sortir de la bibliothèque sans la permission du bibliothécaire. Pour emporter les livres chez vous (qu'ils soient reliés ou non) vous devrez toujours en délivrer un reçu au bibliothécaire et vous serez tenu de les rapporter le lendemain. Le bibliothécaire vous donnera les renseignements nécessaires pour que vous puissiez vous servir aisément de la bibliothèque.

Vous nous obligerez en avertissant le bibliothécaire des irrégularités que vous pourrez trouver dans les livres (feuilles détachées, planches déchirées ou perdues). Ayez soin de tenir les livres hors de tout contact avec l'eau de mer, et de ne pas les tacher avec des signes ou des notes.

Avant votre départ ayez la bonté de remettre tous les livres à leur place et de demander au bibliothécaire s'il n'a pas par hasard quelque reçu de vous.

The series of Contributions to Knowledge are intended to record results of original researches in science, for the *increase* of knowledge. In this series there has been put in course of publication during the year a memoir by Dr. Carl Barus upon experiments in ionized air, a work which, as mentioned above, was carried on with a grant from the Hodgkins fund.

To the series of Miscellaneous Collections there have been added a bibliography of chemical dissertations compiled by Dr. Bolton, and an article on the "Cheapest form of light," the latter being a reprint of a paper by the Secretary and Mr. Very, originally published in the American Journal of Science, for which there has been a continued demand.

There have also been added to the Miscellaneous Collections two volumes containing the legislative history of the Institution from the announcement of the original bequest in 1835 to the year 1899. It is prepared by W. J. Rhees, of this Institution. This work was published also in a Congressional edition.

As year by year the publications of the Institution and of its bureaus are increased in number it is believed that its influence, not only in the "increase" but in the "diffusion" of knowledge, is felt in a greater degree. This is manifest by the greater popular demand for publications, particularly the General Appendix to the Secretary's Annual Reports, in which the aim has been to consider the diffusion of knowledge among the masses of the people, and to create a desire for a better understanding of the important relations that exist between scientific studies and the needs of our daily life.

It will be remembered that under the general printing law, besides the limited document edition of the Smithsonian Report distributed to certain designated depositories, only 3,000 copies are now published by Congress for the use of its members, and 7,000 copies for distribution by the Institution, but it is earnestly to be hoped that a larger edition will be authorized to correspond with the increased popular demand.

With regard to this larger edition, it may be said that it was a custom, introduced by the first Secretary of the Institution, Joseph Henry, of honored memory, to give a certain number of timely articles of an instructive but wholly popular and nontechnical character in the General Appendix to the Secretary's Report.

The experiment was tried under his immediate successor of publishing in place of these an annual résumé of the science of the world, which undertaking was soon found to be an impractical charge, if done on a desirable scale, and nearly useless with anything less; and the present Secretary, believing, with Secretary Henry, that the Institution's function for the diffusion of knowledge was only less important than that for its increase, resumed and extended the early plan of giving short memoirs by writers of authority who are able to present new facts in a nontechnical manner, thus furnishing a summary of the more important progress made in all departments of science during the year elapsed, supplemented by a few papers relating to more remote periods, as in the case of oriental research.

This summary has had the Secretary's increasing attention for the last two or three years, not only because of its intrinsic importance, but since the Institution thus becomes more widely known to those whose help it desires.

The Secretary has given an unusual amount of personal care to the General Appendix of the Report for 1900,<sup>1</sup> which contains 43 articles on various branches of science as enumerated on another page, in the report of the editor.

The Annual Report of the Institution for 1899 has been distributed and the report for 1900 has been put in type, but the latter volume was not received from the Public Printer in time for its distribution to the general public before the close of the fiscal year.

There was also received from the Printer a delayed portion

<sup>1</sup>As the Report for 1900 marks the close of the century, considerable space is given to reviews of the progress in various branches of science during the nineteenth century, prepared by men distinguished in their various fields. The subjects thus reviewed are astronomy, chemistry, geology, physics, electricity, geography, biology, medicine, psychical research, which, with an article on the "Century's great men of science,"<sup>2</sup> furnish in brief a picture of scientific activity of the last century.

China, which has figured so much in the public eye during the year past, is given especial prominence. There is a brief sketch of the Peking Observatory, the looting of which created so much comment; an article by the Chinese minister, Wu Ting-Fang, on mutual helpfulness between China and the United States; Chinese folklore and some Western analogies, and an exceptionally interesting account of the loot of the Imperial Summer Palace at Peking in 1860. This latter is an abridged translation from



of the Museum Report for 1897, being a memorial volume of Dr. G. Brown Goode.

In addition to the preceding publications by the Institution proper a considerable number of works, chiefly on biological topics, have been added to the Museum series. The Bureau of Ethnology completed the Seventeenth Report, which has been considerably delayed in publication, and progress was made on the Eighteenth and Nineteenth reports.

The Secretary during the year transmitted to Congress the Annual Report of the American Historical Association for the year 1900, and also the Third Report of the National Society of the Daughters of the American Revolution.

#### LIBRARY.

It will be remembered that the Institution, besides its deposit in the Library of Congress, has retained in its own building a limited number of scientific periodicals, together with a small collection known as the "Secretary's library," dealing principally with works of art and pure literature, and a still more limited one of books furnishing interesting reading for the employees of the Institution, which is designated as the "Employees' library."

The detailed report of the librarian will be found later, but he states that there have been added during the year over 30,000 volumes, pamphlets, and charts, exclusive of the libraries of the National Museum and the Bureau of American Ethnology, but including all other branches. Of the accessions, by far the greater part were assigned to the Smithsonian deposit in the Library of Congress.

a journal written by Comte D'Herisson, who was on the staff of the French general during the Anglo-French expedition to China in 1860 and an eyewitness of the extraordinary scenes he describes. It appears to have entirely escaped attention during the late crisis, although it has an interesting bearing on recent events and illustrates in a curious manner how history repeats itself.

Aëronautics, which only in the last decade has been growing to be considered a science, has several articles devoted to it by M. Janssen, Lord Rayleigh, Secretary Langley, and others.

Among the thirty or more other articles there may be mentioned, as illustrating the variety of the subjects treated, papers on malaria and the transmission of yellow fever, by Surgeon-General Sternberg; an essay on Huxley, by Professor Brooks, of Johns Hopkins, and a paper on so practical a subject as incandescence mantles.

The Secretary has lately arranged with the Librarian of Congress that the Smithsonian set of any periodical of art or science, or set of transactions of learned societies in that Library, shall be considered and kept as a primary set, or, if incomplete, shall, under this title, be supplemented by volumes of any broken sets already in that Library's possession. If there still be duplicates in the Library of Congress, it is understood that these and not the Smithsonian copies shall be disposed of.

On the other hand, he has also agreed that in the division of Government documents in the Library of Congress the Smithsonian sets, excepting those which include special scientific publications, shall be transferred to the main collection of the Library of Congress.

No action has been taken with regard to the large number of sets or single volumes on general subjects which do not fall under the above heads, and these are left under the existing arrangements.

With regard to those which already form a portion of the Smithsonian deposit, the Librarian of Congress has said, and the Secretary has agreed to the justice of his representation, that while it is abstractly desirable that the entire Smithsonian library should be kept together, there may be cases where the general interests of the public will be served best by taking a portion of these and classifying them with others. It is understood in every case that all volumes belonging to the Smithsonian deposit are distinctly so marked, carrying with them, therefore, the evidence of their ownership.

This general agreement, which requires much detailed work, will finally result in giving a more coherent character both to the Smithsonian deposit and to the Library of Congress itself, and is in the mutual interests of both establishments.

The Institution is indebted to the courtesy of the Librarian of Congress also for establishing an arrangement whereby twice a day books are brought to the Institution by the Library of Congress and returned thereto. This has rendered possible the sending up of a much larger number of publications than heretofore, no less than 200 boxes, each containing the equivalent of 40 large octavo volumes, being sent up during the past year. The possibilities in the direction of increasing the Smithsonian deposit in the Library of Congress and of

filling up deficiencies are unlimited, except by the very small force that can be put upon this work; and both establishments would be much benefited if a larger force were available.

The Smithsonian shelving in the Library of Congress is of steel, iron, and marble, comprising 19,362 running feet of shelves, while the bridges are mainly of steel and essentially fireproof.

#### INTERNATIONAL CATALOGUE OF SCIENTIFIC LITERATURE.

The Regents, through their first Secretary, Joseph Henry, appear to have originated this undertaking in a communication which he was authorized to make to the meeting of the British Association for the Advancement of Science at Glasgow in 1855, suggesting the formation of a catalogue of memoirs. The Smithsonian Institution had not the means of carrying out the plan, which was referred to the Royal Society, who approved it and secured a grant from the English Government under which 11 volumes have now appeared. In the preface to the first volume we read "The present undertaking may be said to have originated in a communication from Dr. Joseph Henry, Secretary of the Smithsonian Institution."

In March, 1894, the Royal Society issued a circular to learned societies throughout the world proposing a great international subject catalogue.<sup>1</sup> In 1895 the Department of State received from the British ambassador an expression of hope on the part of the English prime minister, Lord Salisbury, that the United States Government would be represented at a coming conference on this subject. The matter was referred by the Secretary of State to the Secretary of the Smithsonian Institution, who recommended that the Government should take such part and suggested the names of delegates, a recommendation which was duly adopted. It is sufficient now to recall that the seed which the Institution planted has grown into this great enterprise, in which almost all modern nations, except the United States, have taken an effective part.

In the report for last year the Secretary stated to the Regents the reason for the absence of an official delegate at the Third

---

<sup>1</sup>The reader who may care to look at the history of the subject is referred to articles by the Librarian of the Institution, published in "Science" on August 6, 1897, and on June 2 and 9, 1899.

Conference on the International Catalogue of Scientific Literature, held in London June 12 and 13, 1900. It was learned afterwards that Mr. Putnam, the Librarian of Congress, who happened to be present in London, had private conferences with some of the representatives, and greatly aided them in reaching a conclusion. It was decided at that time to proceed with the catalogue if 300 subscriptions, at \$85 per annum, for a period of five years, could be obtained, and the quota for the United States was fixed at 45 sets. It being necessary to secure these before the end of September, 1900, the Secretary, as an evidence of the Institution's good will, sent out a circular letter commending the project to American institutions of learning. By the end of September the above number had been secured, thus assuring the publication of the work in England, and this number has since been increased to the equivalent of over 66 sets, at \$85 apiece, for five years, representing a sum of about \$30,000, the largest subscription made to the catalogue by any single country, a fact which abundantly demonstrates the interest felt in the catalogue on the part of scientific men in the United States.

It is greatly to be regretted that no adequate provision has been made for the cataloguing of the scientific literature of the United States, which is to form a part of it. The Secretary has provisionally undertaken to do this work out of the private funds of the Institution, in what is feared will be an inadequate way, since only two assistants can be allotted for the purpose, and the Secretary has felt able to retain these only to June 30, 1902. It has indeed been quite clear from the outset that this work could not be made a perpetual charge upon the small Smithsonian fund; but with a full recognition of the importance of this project, the Secretary is still not willing to have the Institution itself solicit aid from Congress for it, while other interests already committed to the Institution are so inadequately provided for and demand its first care.

There is yet hope that some way may be found by which this country may take its proper share in the community of nations. In this great undertaking, which is now being carried on by England, France, Germany, Russia, Italy, and Austria, the Institution, which is not soliciting for itself any Congressional aid, will be glad to see Congress place the work in any effective hands, or, if the Institution itself be designated, it will do its part if Congress shall so direct and provide the means.

## CORRESPONDENCE.

The correspondence of the Institution, next to its publications, furnish, perhaps, the most effectual means of diffusing knowledge concerning matters of purely scientific interest, as well as of disseminating information of a popular nature on subjects coming within the scope of the Institution's work. The inquiries which come to the Institution from all parts of the world embrace almost every conceivable topic, and the major portion of the correspondence relates not to matters of a routine nature, but to widely diversified subjects of scientific investigation. Thus the expenditure of a very considerable amount of time and labor is necessitated, as it is endeavored in every instance to respond as fully as possible to the requests for information, though where the subject of inquiry is clearly without the scope of the Institution, the communications are referred to the branch of the Government service having special cognizance of the matter or matters to which they relate. Where the inquiries have particular reference to the activities of the bureaus administered under the Institution, they are referred to the bureau concerned in each case for attention and answer, unless they involve matters of policy, in which event they are returned for the Secretary's action.

The plan adopted in 1890 of registering such letters as are of sufficient importance to make a record of them desirable, has been continued in operation during the year and has constituted an efficient check against their loss or temporary misplacement.

The increasing demand for publications of the Institution has necessitated an increase in the amount of correspondence relating to their distribution, though this has been considerably reduced by the employment of printed forms. Aside from the letters sent out relating to the operations of its several bureaus, special correspondence has been conducted on aërodromic matters and in the administration of the Hodgkins fund. Since the Smithsonian bureaus were put under the civil-service law and rules in July, 1896, there has been a steady increase in the amount of correspondence relating to civil-service matters, and this has added perceptibly to the labors of the Institution.

## EXPOSITIONS.

The Institution and its bureaus were represented in the Government building at the Pan-American Exposition by an extensive exhibit prepared under the general direction of Dr. F. W. True, of the National Museum, who was designated by the Secretary to represent the Institution on the Government Board. Mention of this subject will be found in the reports of the Museum and other bureaus.

## MISCELLANEOUS.

*Glasgow University.*—The congratulations of the Institution were extended to the University of Glasgow on the occasion of its ninth jubilee celebration in June, 1901, and upon its invitation that a representative of the Institution be appointed to participate in the ceremonies, the Secretary designated Dr. Theodore N. Gill to serve in that capacity.

*Congress of Americanists.*—In June, 1901, the Secretary designated Maj. J. W. Powell, Mr. W. H. Holmes, and Mr. F. W. Hodge to represent the Institution on the general committee of arrangements for the International Congress of Americanists, to be held in New York City in the autumn of 1902.

*Professor Henry's laboratory notes.*—During the long course of scientific researches by Secretary Joseph Henry resulting in his discovery of the electro-magnet, which is practically the basis of the telegraph and of most of the electrical devices of the present day, he kept minute notes of each day's experiments. While it has not seemed necessary to publish these notes in full, it has appeared of interest that the most important original memoranda showing his methods of work should at least be made public, and after consultation with Secretary Henry's family a competent person has been placed in charge of the compilation of these notes in a form that will make a good-sized octavo volume, to be illustrated by a considerable number of reproductions of Professor Henry's original sketches.

*Nobel prize competition.*—The Institution has been informally advised that, in accordance with a bequest from Dr. Alfred Nobel, the conditions of which are not dissimilar to those under which the Hodgkins fund of the Institution is adminis-

tered, the Swedish Government has established a competition designed to stimulate discoveries in the service of humanity.

As specified by the testator, the income from Dr. Nobel's fortune is to be distributed annually in very considerable rewards, say \$40,000 each, to those who during the past year have rendered the greatest service to the world in the domains of physics, chemistry, physiology and medicine, literature, and in the work of fraternizing nations, reducing or suppressing standing armies, and propagating peace congresses.

In view of its entire approval of the testator's objects, the Institution makes this mention of this subject, with which it has otherwise no official connection.<sup>1</sup>

*Santa Fe Palace.*—On March 20 the governor of New Mexico approved a joint resolution of the Territorial legislature "asking for the establishment of a branch of the Smithsonian Institution in the old palace at Santa Fe, N. Mex." This resolution is as follows:

[House joint resolution No. 7.]

Whereas the building in the city of Santa Fe, known as the Palace, is the oldest public building and the most historic

---

<sup>1</sup>Alfred Nobel died at San Remo December 10, 1896. His will provided that the *interest* on the capital bequeathed should be annually divided into five equal parts to be awarded as prizes to those persons who should have contributed most materially to benefit mankind during the year immediately preceding, as follows: One part to be given to the person having made the most important discovery or invention in the science of physics; one *to* in chemistry; one *do.* in physiology or medicine; one *do.* for the most distinguished work of an idealistic tendency in literature, and one *do.* to the person who shall have most or best promoted the fraternity of nations and the abolishment or diminution of standing armies and the formation and increase of peace congresses.

The contest of the will by the heirs at law is now over, and the statutes under which the awarding of the prizes is to be made are formulated and the first awards are to be made in 1902.

Under the statutes "It is *essential* that every candidate for a prize under the terms of the will be proposed as such in writing by some duly qualified person. A *direct* application for a prize will *not* be taken into consideration.

"The right to hand in the name of a candidate for a prize shall belong to  
 "(1) Home and foreign members of the Royal Academy of Science in Stockholm.

"(2) Members of the Nobel Committee of the Physical and Chemical Sections.

edifice in the United States, having been the seat of governmental power and the home of the executive officials of New Mexico through all the changes in government for three centuries; and

Whereas New Mexico itself is more prolific in archaeological treasures than any other part of the Union, and has already contributed more largely than any other State or Territory to the National Museum, and it is desirable that its peculiar historical objects should be preserved in one place, and amid their natural environment, instead of being scattered all over the world; and

Whereas the Territorial legislatures of 1882 and 1884 asked that this historic edifice be devoted to the preservation of the antiquities of New Mexico, and two Secretaries of the Interior have officially recommended that its permanent use be that of a museum of the antiquarian collections of the Southwest; and

Whereas, by inadvertence in the wording of the act of Congress which donated public lands to the Territory for educational and other purposes, passed June 21, 1898, the palace property was included in the cession made by the United States to Mexico, without any wish for such cession on the part of our people; and

Whereas the two houses of the last legislature, each by a

---

“(3) Scientists who have received a Nobel prize from the Academy of Science.

“(4) Professors, whether in ordinary or associate, of the physical and chemical sciences at the universities of Upsala, Lund, Christiania, Copenhagen, and Helsingfors, at the Caroline Medico-Chirurgical Institute and the Royal Technical College in Stockholm, and also teachers of the same subjects who are on the permanent staff of the Stockholm University College.

“(5) Holders of *similar chairs* at other universities or university colleges, to the number of at least six, to be selected by the Academy of Science in the way most appropriate for the just representation of the various countries and their respective seats of learning.

“(6) Other scientists whom the Academy of Science may see fit to select.”

At the time of Nobel's death his estate was estimated to have a value of from 30,000,000 to 35,000,000 kroner, which, if invested at 3 per cent, would yield an annual income of from \$240,000 to \$270,000. Each fifth would thus amount to \$48,000 to \$55,000. Since then 1,500,000 kroner have, by agreement with the heirs at law, been set aside for the foundation of Nobel institutes in Sweden; but at the same time the interest for the intervening years since Nobel's death has been accruing, so that the exact value of each annual prize is not now known.

Inquiries concerning the Nobel competition should be addressed to the Council of the Nobel Foundation, care of the Royal Academy of Science, Stockholm, Sweden.



unanimous vote, passed a joint resolution asking the United States to reassume ownership of said property, and that a western branch of the National Museum be established at the Palace: Now, therefore, be it

*Resolved (if the council concur)*, That this legislature considers that the appropriate future of the palace should be as the home of the great collections of archaeological and other antiquities of New Mexico and the Southwest.

*Resolved*, That we request the authorities in charge of the National Museum of the Smithsonian Institution to establish a southwestern museum of the character hereinbefore indicated as the palace property, with the ancient palace itself as the center.

*Resolved*, That the Territorial board of public lands be authorized and directed to convey said palace property either to the United States or to the Smithsonian Institution, upon the condition that a branch either of the National Museum or the museum of the Smithsonian Institution be established and maintained therein; that the palace building be preserved in good order and without material changes in its general structure and appearance forever; that the New Mexico Historical Society be allowed such space in said building as it may require for the proper exhibition of its collection of New Mexican antiquities and other objects illustrating the history of the Territory as a part of said general exhibition; that the exhibition rooms in said building be open to the public without charge forever; and that no expense for arrangement or maintenance of said building and its contents be a charge on New Mexico or any civil division thereof.

Inasmuch as the offer on the part of the Territory of New Mexico, if accepted by the Smithsonian Institution, would involve the transfer of valuable real estate in the city of Santa Fe, the Secretary has held the question of acceptance for such action as the Board of Regents may deem desirable.

### NATIONAL MUSEUM.

The National Museum is visited annually by about a quarter of a million persons, and each one seems to desire to examine as many as possible of its treasures, now numbering nearly 5,000,000 objects pertaining to the anthropological, biological, and geological sciences.

Through its publications and its correspondence the Museum reaches everywhere, giving to the world information of a technical or of a popular character concerning the American and alien races of men and their habits, the life history of

animals and plants, and the structure and composition of the earth.

The Secretary, in his report for 1888, called attention to the inadequacy of the Museum building, which even then, within seven years after its completion, was found to be wholly insufficient for the collections. The subsequent history of the Museum has been a continuous recital to Congress by the Regents of its increasing inadequacy.

The Secretary feels it his urgent duty to call attention to the absolute need of an additional, more modern, building for the National Museum, wherein may be properly exhibited objects now packed in the present structure, and where may be set up before the public, whose property they are, very many objects of scientific, historical, and popular interest now in storage quarters. Too much can not be said in urging this all-important matter, and it is hoped that definite action may finally be taken by Congress.

The Secretary repeats here, what he already said in 1888, that not only is large additional space required to relieve the congested condition of the present building, but that the appropriations have become utterly insufficient, even for the proper care of the collections. It is hoped that Congress may see fit to remedy these conditions and to give larger appropriations this year.

The Secretary repeats also that it is not alone the lack of space that is keenly felt, but the absolute inadequacy of the appropriations in maintaining a corps of efficient assistants to care for the collections. The accompanying table will perhaps tell the story better than any amount of description.

If we take the five years extending from 1881 to 1886 as a basis for comparison, the appropriations were at the rate of \$1,000 for the care of about 6,000 specimens. This was represented at the time as insufficient, and divers expedients were resorted to, such as the creation of honorary and unpaid curators to perform the work. At present \$1,000 are provided for the care of about 21,000 specimens, and proper care at anything like this rate is simply impossible. The number of specimens has increased nearly five times, while the amount of money appropriated for their care has not doubled.



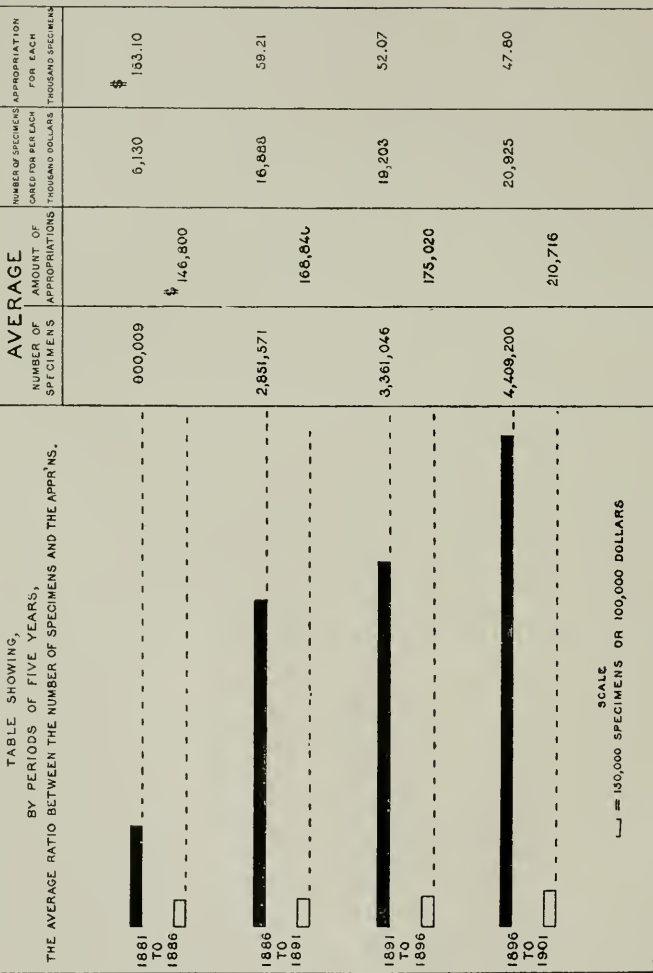

RELATIVE INCREASE OF COLLECTIONS AND APPROPRIATIONS, UNITED STATES NATIONAL MUSEUM  
1881-1901

When Congress comes to appropriate for the increase of space to over twenty times what it is at present (which amount will be necessary to provide for our present collections on a scale of space only commensurate with that now allotted, for example, by the American Museum of Natural History), it will be found that the Museum's most valued property does not lie only in the granite walls of its new building, if it have one, nor in the cases, nor in the specimens, however important these may be, but in its possession of a corps of long-trained and long-experienced workers.

This band of collaborators has continued its labors in most cases while their duties have been growing more onerous and their pay has remained practically stationary, because its members are as a rule working for the love of their work rather than for pay; but unless more adequate provision is made now, the Museum, when Congress has granted new quarters for it, will not be able to take into them those who in the past have made it what it is, these men, its best possession, who are now going and who will have gone.

It is always to be remembered that the collections and specimens referred to have not been purchased on any digested plan, and though in themselves often very valuable, are mainly derived from Government expeditions often organized for purposes other than collecting, from gifts, and from other sources, and that their usefulness is always impaired unless the gaps between them are filled. A small appropriation was provided for this purpose—that is, chiefly the filling of gaps in the collections, in 1898—but the amount available is so limited and the deficiencies in the collection so great that it will be impracticable to add any new series of objects at present. It is hoped that Congress may hereafter grant larger sums for this purpose and for such unique characteristic American objects as are rapidly disappearing.

The Secretary does not wish to say that the National Museum, under this absolute denial by Congress of its indispensable means of existence, has fallen to a second place among American museums, but he would ask a comparison between it and others which were once its inferiors.

Taking a single instance, that of the American Museum of Natural History—the museum of the State of New York—some statistics have been secured with regard to its size and

cost of administration and contrasted with similar data bearing upon this Museum—the museum of the whole United States:

*Statistics of the United States National Museum compared with the American Museum of Natural History.*

	National Museum.	American Museum of Natural History.
Cubic feet in building.....	3,600,000	38,000,000
Number of specimens.....	4,994,672	2,300,000
Space provided for each specimen.....	$\frac{7}{10}$ of 1 cubic foot.	16 $\frac{1}{2}$ cubic feet.
Income, 1901.....	\$263,540	\$230,000
Salaries paid to curators.....	<sup>a</sup> 22,199.76	\$44,000
Cost of buildings to date.....	\$391,400	\$4,000,000
Expenses for all purposes, 1901.....	<sup>b</sup> \$246,824.67	\$230,000

<sup>a</sup>Total paid to entire scientific staff, \$51,649.45.

<sup>b</sup>Balance of appropriation held to meet outstanding liabilities.

It has been possible during the year to arrange for a new lecture hall in the Museum, a feature which for several years seemed to be of public importance but which was of necessity temporarily abandoned. The present hall is well equipped for its use, being provided with a convenient platform, a lantern stand, screen, chairs, and adjustable window screens.

Progress has been made in the installation of electric arc lamps throughout the Museum halls, and it is expected during the coming year to complete the work so that the building may be opened at night when occasion or order of Congress should require it.

Much-needed improvements are being made in the heating system by the installation of new boilers in the Museum and the connection by a tunnel with the Smithsonian building, rendering it possible to considerably economize the service by heating both buildings from one center instead of by two plants as heretofore.

Among other improvements of the year it may be mentioned that the last of the old temporary wooden flooring of the Museum halls has been entirely replaced by permanent terrazzo pavement.

The report of the Assistant Secretary enumerates somewhat in detail the accessions to the several departments of the

Museum during the year, aggregating about 180,000 specimens, among which may be here mentioned ethnological material collected by officers of the Army and Navy in southern California, British Columbia, and Alaska, some facsimiles of ancient codices presented by the Duc de Loubat, and aboriginal objects of much interest from Brazil and other parts of South America. Special attention is also called to the valuable collection transmitted from the Far East by Dr. W. L. Abbott, who has already contributed so largely to the Museum as the result of his extensive explorations.

Among other newly acquired collections of interest are objects of flint, illustrating the stone-shaping art of the primitive Egyptians, presented by Mr. Seton-Karr, of London, and a very full series of stone implements and other relics, principally from Maryland, presented by Mr. J. D. McGuire.

The biological department has been enriched by collections of special interest gathered by collaborators of the Museum in various parts of the world, including marine zoological specimens gathered in connection with the expeditions of the Fish Commission steamers *Albatross* and *Fish Hawk* in the Pacific Ocean and the region of Porto Rico. It has been possible to secure by purchase upwards of a thousand specimens of North and Central American birds, and by donation there has been received a large number of the eggs and nests of Philippine birds.

Among the geological additions of the year are several thousand fossils from various regions, one of the most interesting being a fairly complete skeleton of an adult female mastodon from Michigan.

During the past twenty years it has been possible for the Museum to distribute duplicate specimens to a considerable number of institutions of learning in this country, and very much more could be accomplished in this way were funds available for the preparation of additional collections of this kind. Wherever these series have been sent, they are highly appreciated, and the demands from other institutions for similar contributions are constantly increasing.

It is all important that every object exhibited in the Museum be suitably and permanently labeled, and while it is gratify-

ing that much progress has been made in this work in recent years, many specimens still remain with only temporary labels. During the past year but little could be accomplished in this direction, owing to the large demand upon the time of Museum officials in connection with the preparation of exhibits for the Pan-American Exposition, and also the present inadequate facilities for label printing. Attention in this connection is called to paragraphs below on the possible treatment of labels so as to render them not only valuable for scientific classification, but also instructive and interesting to the public.

The Secretary has endeavored each year to make some advance in the direction of the Institution's primary purpose of the increase of original knowledge through observation and research by the eminent men who are acting as its immediate curators. What has been done in this way will be found indicated in the Museum reports.

He is at this moment speaking, however, of only a subordinate, though not unimportant, portion of the Museum's work, that of instruction and entertainment, and toward this end he has with personal attention brought together in one of the halls of the Smithsonian building a small collection which has been called "The Children's Room" (though it appears to interest adults at least as much as children), comprising objects of interest rather than of practical instruction. The room itself has been made attractive by a careful choice of color and design in the decoration of the walls and ceilings, embodying illustrations of the life of animals and plants.

The objects displayed in the room include cages of living birds, aquaria with fishes, and cases filled with those things which interest children even of a larger growth.

As the Secretary stated in his last report, the classification "is not that of science, but that which is most intelligible to the untrained mind," and is intended for the purpose of exciting the interest and wonder of the youthful visitor, in the ultimate hope that this will stimulate a desire for knowledge in natural history.

The Secretary takes this occasion to express the hope that this small special collection may have a possible use beyond its immediately declared purpose. It is only within the last



few years that scientific men have begun to collect and publish in methodical form the life histories of birds and other animals, and it is believed that they are beginning to take an increased interest in reducing the results of their researches to popular form for the entertainment and instruction of the larger public, on whose support with Congress, the pecuniary means for higher learning itself must also depend.

With regard to this, the Secretary will quote from a previous report to the effect that "if the first purpose of a museum be for the increase of original knowledge by investigation and research, its second purpose is to entertain as well as to instruct."

The Secretary has elsewhere quoted the definition of an educational museum as "a collection of instructive labels, each illustrated by a well-selected specimen." It is believed that the National Museum of the Smithsonian Institution has led in the practice of making its labels generally instructive; and yet it may be properly asked whether the labels in the collections even in our own Museum, or in almost any other, are a collection of instructive labels for the general public.

The Secretary expresses the wish that still further progress in this direction of instructing and interesting the public may be made, and he suggests, as one legitimate means of doing it, not any change in the present labels or in the Latin names of the specimens, which should always remain, but an addition to each, or at least to the labels of the more popularly interesting specimens, giving briefly in English some characteristic, and if possible some *interesting* characteristic, of the specimen in question.

Again repeating that the first purpose of the Museum is to aid investigation and research, and that this will always have his first attention, he recalls that there is a subordinate but most valuable purpose, and he wishes to say now what has been increasingly in his mind for years, that he would feel he had been promoting a most useful work if he could be the means of inducing all museums to systematically add to existing labels (on at least all the most interesting or characteristic specimens) something which would bring their subject within the reach of the unlearned public.

To illustrate the very slight modification necessary to carry the suggestion into effect, there is given below an example of the usual label and of the modified form which, adding a single sentence, furnishes additional information of a popular character.

45<sup>2</sup>**CRESTED FLY-CATCHER.**

Great Yellow-bellied Flycatcher.

**Myiarchus crinitus** (LINN.)*Hist. N. Am. B., II, p. 334, pl. xliii, fig. 3.*

Eastern United States and British Provinces,  
but rare northeastward beyond the Connecticut  
Valley; west to edge of the Great Plains; in  
winter, Central America to Nicaragua.

45<sup>2</sup>**CRESTED FLY-CATCHER.**

Great Yellow-bellied Flycatcher.

**Myiarchus crinitus** (LINN.)*Hist. N. Am. B., II, p. 334, pl. xliii, fig. 3.*

Eastern United States and British Provinces,  
but rare northeastward beyond the Connecticut  
Valley; west to edge of the Great Plains; in  
winter, Central America to Nicaragua.

This bird ornaments its nest with the cast-off  
skin of a snake, the purpose being apparently to  
frighten off intruders.

## BUREAU OF AMERICAN ETHNOLOGY.

Researches among the native American tribes have been continued in the Bureau under the immediate supervision of Maj. J. W. Powell, its Director. The operations of the year were conducted in accordance with the act of Congress approved June 6, 1900, and with the formal plan adopted by the Secretary June 19, 1900.

As heretofore, the work has been carried forward in such manner as to aid in advancing the science of ethnology, and the Director has given much attention to the development of a classification of the native tribes on the basis of their normal activities. It is thought that, in addition to its immediate

utility, this work will constitute an important contribution to the sciences dealing with mankind.

Field work was prosecuted in Alaska, Arizona, California, Maine, New Mexico, New York, North Carolina, Virginia, and Wisconsin, as well as in British Columbia and Ontario, Canada, and in Lower California and Sonora, Mexico. Additional data were received from correspondents and collaborators in other sections.

One of the noteworthy expeditions of the year traversed the arid regions of Arizona, Sonora, and Lower California along new routes, and resulted in discovering the recent extinction of the Tepoka Indians, in defining the western boundary of the territory occupied by the Papagos, also in the first scientific study of the Cocopas living in the Lower Colorado River region. Among these Indians a collection was made for the National Museum, portions of which were subsequently used in the exhibit at the Pan-American Exposition in Buffalo. The Cocopas were found to present various features of interest both to scientific students and to statesmen. The work of the expedition was facilitated by several officers of the Republic of Mexico, including His Excellency Señor Don Manuel de Aspiroz, the ambassador from Mexico to the United States, whose courtesy it is a pleasure to acknowledge. An extensive archaeological reconnaissance was made also through central and southeastern Arizona, where various ruins of ancient habitations were examined. Linguistic records of great value were obtained by a collaborator among the Haida Indians in British Columbia.

Valuable collections were made or acquired during the year—a typical series of stone implements from Georgia, a collection of artifacts in stone and clay from southern California, the Cocopa collection already mentioned, and a series of obsidian blades from California being most notable.

As during previous years, numerous photographs of aborigines were taken both in the field and from Indian delegations visiting Washington, and toward the close of the year a number of kinoscope views, or motion pictures, were obtained for purposes of study and record.

The work in the office covered a wide range of topics pertaining to the characteristics and products of the aborigines.

Among the reports prepared for publication, one embodying a series of symbolic paintings of ritualistic character, which may be termed a Codex Hopiensis from the tribe in which it was found, is of peculiar interest. Another report of special note relates to wild rice as an aboriginal food source, and touches on the utilization of this plant by white settlers. The publication of the Report was continued with some delay due to the time required for reproducing the illustrations accompanying the papers. The Seventeenth Report and the first volume of the Eighteenth were distributed during the year, while the second part of the Eighteenth was finished to the point of binding; at the same time the Nineteenth Report was edited and proof-read.

The work of the Bureau during the year is described at some length in the Report of the Director.

#### NATIONAL ZOOLOGICAL PARK.

The Secretary recalls to the Regents that the primary purpose for which they sanctioned the establishment of the National Zoological Park was embodied in its name. It was to be a "National" one; and it was not for the City of Washington only, but to be a means of preserving the great animals of the country, and particularly of the North and West, which were in danger of extinction; and it was to exist quite as much for Idaho or Oregon as for the District of Columbia.

It is earnestly to be hoped that Congress will carry out the plan originally urged upon it, of treating this park as it treats the National Museum, that is, as something not existing for the benefit of the District chiefly, nor properly to be maintained by the taxation of its inhabitants. In any case it is to be known that while the National Park has been of a great deal of incidental use to Washington as an admirable place for health, recreation and entertainment, accessible to those who can only go on foot, and offering such charm of scenery as no other public park under such conditions possesses, yet that one of the principal purposes for which it was founded—the preservation from extinction of the national animal races—has not been considered by Congress. About this the Secretary can express himself no better now than he did in his report for

1890, in which, referring to the history of similar attempts, he said:

“In the early part of this century a naturalist traveling in Siberia stood by the mutilated body of a mammoth still undecayed, which the melting of the frozen gravel had revealed, and to the skeleton of which large portions of flesh, skin, and hair still clung. The remains were excavated and transported many hundred miles across the frozen waste, and at last reached the Imperial Museum at St. Petersburg, where, through all these years, the mounted skeleton has justly been regarded as the greatest treasure of that magnificent collection.

“Scientific memoirs, popular books, theological works, poems—in short, a whole literature—has come into existence with this discovery as its text. No other event in all the history of such subjects has excited a greater or more permanent interest outside of purely scientific circles; for the resurrection of this relic of a geologic time in a condition analogous to that in which the bodies of contemporaneous animals are daily seen brings home to the mind of the least curious observer the reality of a long extinct race with a vividness which no fossils or petrifications of the ordinary sort can possibly equal.

“Now, I am assured by most competent naturalists that few, if any, of those not particularly devoted to the study of American animals realize that changes have already occurred or are on the point of taking place in our own characteristic fauna compared with which the disappearance from it of the mammoth was insignificant. That animal was common to all northern lands in its day. The practical domestication of the elephant gives to everyone the opportunity of observing a gigantic creature closely allied to the mammoth, and from which he may gain an approximately correct idea of it. But no such example is at hand in the case of the bison, the prong-horn antelope, the elk, the Rocky Mountain goat, and many more of our vanishing races.

“The student of even the most modern text-books learns that the characteristic larger animals of the United States are those just mentioned, with the moose, the grizzly bear, the beaver, and if we include marine forms and arctic American animals we may add the northern fur seal, the Pacific walrus, the Californian sea elephant, the manatee, and still others.

“With one or two exceptions out of this long list, men now living can remember when each of these animals was reasonably abundant within its natural territory. It is within the bounds of moderation to affirm that unless Congress places some check on the present rate of destruction there are men now living who will see the time when the animals enumerated will be practically extinct, or exterminated within the limits

of the United States. Already the census of some of them can be expressed in three figures.

“The fate of the bison, or American buffalo, is typical of them all. ‘Whether we consider this noble animal,’ says Audubon, ‘as an object of the chase or as an article of food for man, it is decidedly the most important of all our American contemporary quadrupeds.’

“At the middle of the last century this animal pastured in Pennsylvania and Virginia, and even at the close of the century ranged over the whole Mississippi Valley and farther west wherever pasturage was to be found. At the present time a few hundred survivors represent the millions of the last century, and we should not have even these few hundred within our territory had it not been for the wise action of Congress in providing for them a safe home in the Yellowstone Park.

“Now, for several reasons it has been comparatively easy to trace the decline of the buffalo population. The size of the animal, its preference for open country, the sportsman’s interest in it, and its relations to the food supply of the Western Indians, all led to the observation and record of changes; and accordingly I have made special mention of this animal in representing the advantages of a national zoological park where it might be preserved; but this is by no means the only characteristic creature now threatened with speedy extinction.

“The moose is known to be at the present time a rare animal in the United States, but is in less immediate danger than some others. The elk is vigorously hunted and is no longer easily obtained, even in its most favored haunts. The grizzly bear is believed to be rapidly approaching extinction outside of the Yellowstone Park, where, owing to the assiduous care of those in charge, both it and the elk are still preserved. The mountain sheep and goat, which inhabit less accessible regions, are becoming more and more rare, while the beaver has retreated from a vast former area to such secluded haunts that it may possibly survive longer than the other species which I have just enumerated, and which are but a portion of those in imminent danger of extinction.

“Among the marine forms the manatee still exists, but, although not exterminated, it is in immediate danger of becoming so, like the Californian sea elephant, a gigantic creature, often of greater bulk than the elephant, which has suffered the fate of complete extinction within a few past years; at least it is uncertain whether a single individual actually survives. The Pacific walrus, upon which a large native population has always in great part depended for food and hides, is rapidly following the sea elephant, and so on with other species.

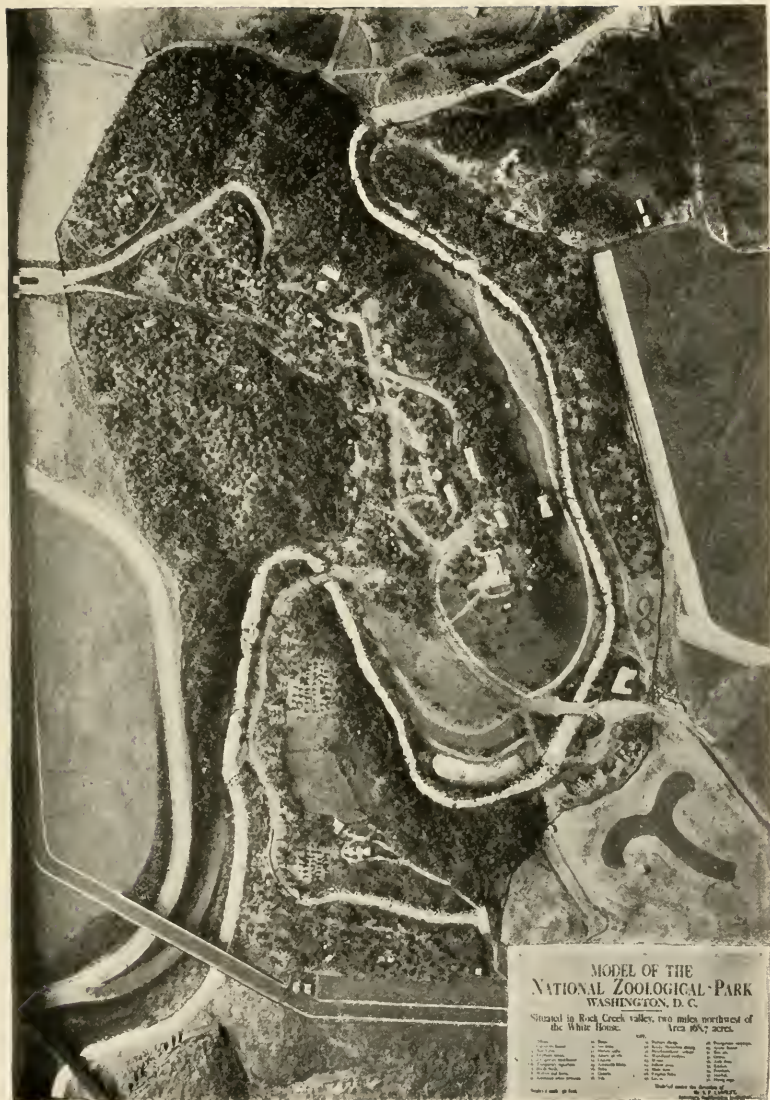





“This appalling destruction is not confined to mammals. Disregarding the birds of song and plumage, to which the fashions of the milliner have brought disaster, nearly all the larger and more characteristic American birds have suffered in the same way as their four-footed contemporaries. The fate of the great Auk is familiar to all naturalists; but it is not so well known that the great Californian vulture and several of the beautiful sea fowl of our coasts have met the same fate, and that the wild pigeon, whose astonishing flocks were dwelt upon by Audubon and others in such remarkable descriptions and which were long the wonder of American travelers, with the less known, but magnificent ivory-billed woodpecker, and the pretty Carolina parakeet, have all become, if not extinct, among the rarest of birds.

“Apart from the commercial value of its skins, the tax upon which has paid for the cost of our vast Alaskan territory, the singular habits and teeming millions of the northern fur seal have excited general interest even among those who are not interested in natural history. In 1849 these animals abounded from Lower California to the lonely Alaskan Isles, and it had been supposed that the precautions taken by the Government for their protection on the breeding grounds of the Pribilof Islands would preserve permanently the still considerable remnant which existed after the purchase of Alaska and the destruction of the southern rookeries. But it is becoming too evident that the greed of the hunters and the devastation caused by the general adoption of the method of pursuing them in the open sea, destroying indiscriminately mothers and offspring, is going to bring these hopes to naught.

“For most of these animals, therefore, it may be regarded as certain that, unless some small remnant be preserved in a semi-domesticated state, a few years will bring utter extinction. The American of the next generation, when questioned about the animals once characteristic of his country, will then be forced to confess that with the exception of a few insignificant creatures, ranking as vermin, this broad continent possesses none of those species which once covered it, since the present generation will have completed the destruction of them all.”

During the eleven years that have elapsed since these paragraphs were written, the writer has presented these considerations every session, with the insistence it seemed to him their importance deserved, until of late years he has had to feel that the opportunity for saving this remnant, which was going more and more each year, had in some respects finally gone. The great Kadiak bear, the largest carnivorous animal upon the planet, since the report above quoted was written, has been driven farther and farther into the interior, until a specimen

is now unprocurable except by the fitting out of a costly expedition, with the remote chance of obtaining a single adult, though such an expedition will probably be more successful in procuring the young.

Something much like this may be said of the giant moose and of other of our semiarctic fauna. The buffalo is so nearly gone, even from its shelter in the Yellowstone National Park, that the stockade which the Institution erected there to secure and "gentle" part of the few buffalo remaining, is falling down without a single one ever having been in it. Taught by the hopelessness of previous applications, the Secretary has limited his request for this purpose to an immediate appropriation of \$15,000, with the now faint hope of securing some of the young of these vanishing creatures—the great bear, the great moose, and the like. The Secretary is prepared to soon abandon recommendations which have been urged for nearly ten years, not only because they have been so far made in vain, but because some term must be set in which they will have too evidently grown useless from the disappearance of the animal races in question.

As to the best means of securing the protection of these races, he has acquired in this long effort some practical knowledge of the difficulties and of the simple but effective remedy which can be applied. The subject is too large a one, however, to treat here, and he will only say that these creatures, if secured and transported immediately from their native haunts, are most unlikely to live under the conditions of civilization. They are, on the contrary, very likely to live and even to perpetuate their species if taken with care and kept surrounded by the protection that experience and common sense suggest; and both these mean the continuance of the present National Zoological Park here under the eyes of Congress, but with a simultaneous provision for first bringing up the wild animals in a commodious place of confinement in the country where they belong (one in Alaska, for instance), large enough to allow them to live without a sense of captivity, on their ordinary food, and in their ordinary climate. This place might be a small ranch, where the things of vital importance after their capture and security—namely, their being "gentled" and accustomed to the sight of the keeper before being transferred to Washington—can be carried out. Such a ranch can be established at a

small cost, which will not be likely to be exceeded, and Congress can be assured that it is not entering into an indefinite future expense if this initial one be approved.

The Secretary will not leave this brief mention of the subject without stating that the walrus, perhaps the sea elephant, some kinds of seal, and many other great aquatic mammals, can equally share in this protection at a similarly small expense, by simply preserving some locality where the walrus now congregate, as, for instance, a known spot on the northern shore of the Alaskan peninsula, or by establishing a more special preserve in some landlocked bay, where they will obtain their natural food and be properly guarded.

As to the local use of the National park, the beautiful region set aside by Congress for it here has proved a fit place for filling the objects of its existence, declared by Congress to be "The advancement of science and the instruction and recreation of the people." for here not only are the national animals, with others, preserved (in connection, it is to be hoped, later with fixed sources of supply), from which the race could be recreated if it died out elsewhere, but the National Zoological Park has become a favorite resort of the nation's visitors to the capital, who find in its shades, along with such landscapes as no other city can show, object lessons of attractive interest—for we must admit that we are all, adults as well as children, interested in our animals, with an attraction which no books about them can supply.

It has been possible to make some needed improvements in the roadways of the park during the year, but many of the buildings are almost falling down. The need of means to put a permanent shelter over the animals can not be overstated. Mention has already been made in this relation of the aquarium building, which consists of a literal barn, and which was brought here until Congress could provide a special one; but although several years have elapsed, none has yet been provided. The elephant house, a small wooden shed, put up as a temporary expedient ten years ago, requires extensive repairs to prevent it literally falling from rottenness.

The wooden fence placed around the park ten years ago, and expected to last four or five years till a permanent one was provided, has never been replaced at all, and has gone beyond repair.

With regard to the birds, more is being done for the better care of the larger ones. There has been designed and partly constructed a large "flying cage," capable of including tall trees within it, which is to be built near the present bird house. The cage will be supplied with running water, and it is hoped that some of the aquatic species may live within its limits.

### THE ASTROPHYSICAL OBSERVATORY.

The most prominent feature of the year's work has been the distribution of the first volume of *Annals of the Astrophysical Observatory*, to which attention was directed in my report of last year. This special volume has been sent to 1,500 Government depositories, observatories, learned societies, and to eminent astronomers and physicists throughout the world. The work will, it is believed, establish an enduring reputation for the observatory from which it proceeded.

The eclipse expedition to Sumatra is spoken of more at length in the detailed report of the Aid Acting in Charge, which will be found in the Appendix. The special occasion for this expedition arose with reference to the observations made under the Government appropriation by the Institution in the solar eclipse of May 28, 1900, at Wadesboro, N. C. These, though valuable, were not in themselves complete, and pointed to conclusions of particular interest which demanded the opportunity of another eclipse to definitely perfect them.

Perhaps the most interesting of these was the incomplete evidence secured on a single photograph of the existence of several small planets within the orbit of Mercury, as indicated in Plate XVIII of the last year's report. Prof. E. C. Pickering, to whom this photograph was referred for his expert judgment, saw nothing in the appearance of the photographic impressions of the supposed planets which would lead him to pronounce them spurious. To make certain of their genuineness would, however, require the evidence of another photograph, and new photographs were only to be supplied by another eclipse.

A second, not absolutely conclusive, observation of great interest was that made by the bolometer on the heat of the inner corona, from which, as stated on page 154 of the Smith-

sonian Report for 1900, certain conclusions were drawn regarding its temperature. These observations attracted widespread interest and discussion among the astronomical public, and it became of importance to verify and extend them if possible.

Hence it seemed to be desirable that an expedition should proceed to the island of Sumatra to observe the long eclipse there. The Institution did not, however, ask for a second appropriation from Congress.

The United States Naval Observatory, which had secured such an appropriation, had courteously offered to take one of the Institution's staff as a part of its own expedition. Since, however, the Institution wanted the Sumatra work to complete its own special work of the previous year, and since it would involve the use of large special apparatus belonging to it, it was deemed better that it should send out a party of its own, though on a most modest scale.

The party sent out from the Institution consisted of Mr. C. G. Abbot, Aid Acting in Charge of the Smithsonian Observatory, and Mr. Paul Draper.

Through the permission of the Secretary of War and by the good offices of Brig. Gen. M. I. Ludington, Quartermaster-General, transportation was secured to Manila and return by the army transport service. The Secretary of the Navy consented that the Institution's expedition should be carried from Manila to Padang and return in the same vessel with the expedition of the United States Naval Observatory. My acknowledgments are further due the Hon. F. W. Hackett, Assistant Secretary of the Navy, for very effective aid in perfecting these arrangements. Letters of introduction to Dutch officials were obtained from the Department of State of the United States, and from his excellency Baron W. A. F. Gevers, minister of the Netherlands.

Mr. Abbot and Mr. Draper sailed on February 16 in the transport *Sheridan* from San Francisco, arriving at Manila on March 15, whence, seven days later, they embarked on the United States naval transport *General Alava*, reaching Padang, Sumatra, on April 4, from which point they proceeded to Solok, a small town in the interior, which, though about twenty-five miles north of the central eclipse track, was chosen as having the best meteorological record of any part of the island, and because of its location on a railroad. Nothing

could exceed the kindness exercised by all the Dutch officials of Sumatra to further the comfort and success of the observers. Free transportation was offered on all government railways, and observing sites placed at their disposal, with native laborers for the installation of equipments. The Secretary wishes to especially acknowledge the indebtedness of the Institution to his excellency Governor Joeke, of Sumatra's west coast, to Heer Th. F. A. Delprat, head of government railways in Sumatra, and to Heer C. G. Veth, United States consular agent at Padang, whose efforts in behalf of the party were untiring.

The little expedition reached Solok April 11 and passed the time in constant drill, being strengthened by native help in erecting instruments. On the momentous day (May 18) the weather proved to be very bad over this portion of the island, and caused the partial failure of the observations, though Mr. Abbot and his companion may feel that while it was not in their power to command success they have deserved it.

They returned under the same assistance from the Army and Navy with which they went out, reaching Washington on the 29th of July.

Attention is called to the progress reported by the Aid Acting in Charge in perfecting devices to increase the actual working sensitiveness of the galvanometer, which is an indispensable companion to the bolometer the instrument which perceives and measures excessively small variations of temperature.

The bolometer, it will be remembered, was invented by the present writer some twenty years ago as an instrument to detect radiant heat in such small quantities as could be recognized not even by the most delicate thermometer, and which were so far beyond the reach of that instrument that the thermopile could not register them. It may seem to the general reader that the recognition of such excessively small amounts of heat can not be of practical importance, but this would be like saying that the human eye was an instrument of no importance to the owner, since the amount of energy which enabled it to see is so inexpressibly small.

The bolometer has been called "an eye which sees in the dark," and it sees only by means of almost infinitesimally

small amounts of heat, but it now sees with these what neither the eye nor the photograph can see. When the writer took charge of the Astrophysical Observatory of the Smithsonian Institution the bolometer, with its attendant galvanometer, could recognize a change of temperature of less than one-hundred-thousandth of one degree Centigrade. With the changes which he and others have since introduced in the instrument and its attendant galvanometer, it can now recognize less than one one-hundred-millionth of one degree. As much as a thousandfold gain in sensitiveness has, then, been attained over the former conditions, and a manifold further increase is hoped for by the use of the more sensitive galvanometer now being developed under the immediate care of Mr. Abbot, the Aid Acting in Charge.

Even with this remarkable progress the bolometer is still far less sensitive than the eye in its capacity to detect radiations of wave-lengths suitable for eye observations, but, as is well known, it has the great advantage that all rays affect it equally, whether visible or not, and that hence it can see where the eye can not.

In this little and inadequately installed Smithsonian Observatory the bolometer has extended the known spectrum to a wave-length many times that known to Sir Isaac Newton, and its use has spread from this country to every physical laboratory in the world where such researches are carried on. It is growing more sensitive each year with continued improvements, to which there seems to be no assignable limit, and its future promises to be as full of value as its past.

The urban situation of the Observatory puts serious difficulties in the way of investigations which, like the one just referred to, require exceptional steadiness and freedom from magnetic fluctuations. An astrophysical observatory should evidently be located where smoke, lights, noise, traffic, and heavy electric currents are at a distance. That the Smithsonian Observatory should still, after twelve years, be in its present situation and with merely temporary wooden buildings for its home is indeed far from the expectations cherished at its inception, a condition of affairs which the Secretary still ventures to hope will be changed.

## INTERNATIONAL EXCHANGES.

The importance of the work accomplished by the International Exchange Service is constantly becoming more fully understood, and the benefits derived from it in the interchange of the publications of the civilized world more adequately estimated. The liberality of the American people in gratuitously supplying their scientific literature to appreciative students of it, wherever they may be, and the provision for its transmission at the expense of the United States Government and of the Smithsonian Institution jointly, creates such an impression abroad that the Institution is often asked for a description of the methods for recording and forwarding exchanges, with a view to enabling others to adopt its system, which for accuracy, labor saving, and as a permanent record for ready reference, years of assiduous study have perfected into what it is to-day.

The term "International Exchanges," to those unaccustomed to its application, may seem ambiguous, but the use of the term is now universally accepted as applying to the mutual exchange between Smithsonian correspondents everywhere of printed books on subjects of interest to the student in any branch of human knowledge.

The Institution adopted the custom of voluntarily presenting its publications to learned societies in the year 1849, when it sent a copy of Volume I of the Smithsonian Contributions to Knowledge to each of one hundred and seventy-three foreign institutions. The recipients of these copies subsequently sent their publications in exchange, and these reciprocal contributions aided in forming the nucleus of the library of the Smithsonian Institution.

As the Institution increased the publication of works on scientific subjects, the exchange with its correspondents abroad also increased, and the facilities for forwarding and distributing the parcels soon led to requests being made by other learned establishments in the United States for their publications to be forwarded abroad by the Institution in the same manner. The purpose of the donor of the Smithsonian fund, "the diffusion of knowledge among men," could not, in the minds of the Regents, be better promulgated than by





**C**HART REPRESENTING THE RELATIVE NUMBER OF PARCELS EXCHANGED BETWEEN THE UNITED STATES AND OTHER COUNTRIES DURING THE FISCAL YEAR ENDING JUNE 30, 1901. EXCHANGES WERE CONDUCTED WITH 130 COUNTRIES. THOSE AGGREGATING LESS THAN 1000 PACKAGES ARE OMITTED. THE AVERAGE WEIGHT OF EACH PARCEL WAS 3 1-2 POUNDS. TOTAL WEIGHT HANDLED DURING THE YEAR 414,277 POUNDS.

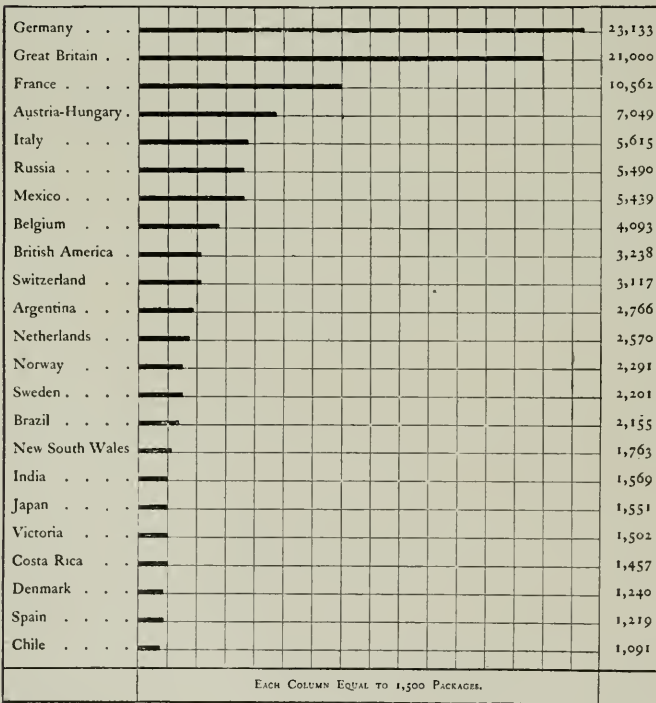

devoting a part of the income of the fund to this purpose, and from that time to the present the Institution has assigned space in the Smithsonian building and has appropriated a considerable part of its annual revenue to the support of the system of International Exchanges.

The United States Government participated to a large extent in the benefits of the exchange system of the Smithsonian Institution for many years without contributing to its support, until the burden became so great that Congress in 1881 made an appropriation of \$3,000 for the purpose, and since then has made larger provision for the service from year to year until \$24,000 was granted for the fiscal year ending June 30, 1900, and a like amount was appropriated for the last year.

Notwithstanding the support of Congress in aid of the exchange service during recent years, none of the appropriations have been quite adequate to the growth of the service and to provide for improvements necessary to expedite exchange transmissions, which, within the last two years, have been unusually large. In order to accomplish these improvements it has been necessary to substitute fast mail steamers for the slower ones upon which the ocean transportation companies usually granted the Institution the courtesy of free freight, and in demanding the best possible facilities it has been necessary in most instances to pay the customary rates.

The field covered by correspondents of the Smithsonian Institution and the contributors and recipients of its exchanges is now represented by one hundred and forty-eight countries, covering every part of the civilized world and extending to several countries where enlightenment has only commenced to manifest itself. In the latter are some of the most appreciative correspondents of the service.

Outside the United States the Smithsonian correspondents now number twenty-seven thousand five hundred and fifty-six (27,556), and including this country there is a grand total of thirty-five thousand seven hundred and five (35,705), an aggregate increase of seventeen hundred and fifty-four (1,754) during the year.

The parcels received for transmission this year number one hundred and twenty-one thousand and sixty (121,060)

(many of which contained several separate publications), representing an increase over the previous year of seven thousand four hundred and ninety-seven (7,497). The relative amount of exchanges with various countries is graphically shown in the accompanying chart.

A total of sixty-two thousand three hundred and fourteen (62,314), or more than half the number of parcels delivered to the International Exchanges, were either received from the departments and bureaus of the United States Government for transmission abroad, or were received for them from abroad, and constituted fully 75 per cent of the total weight of all transmissions for the year. This branch of the service is then of value to the Library of Congress and the departmental and sectional libraries of every branch of the Government.

In his last report the Secretary presented an account of his visit to London and Berlin during the summer of 1900 for the purpose of impressing upon the British and German Governments the desire of the Institution that they should each establish an international exchange bureau, or at least arrange for the transmission and distribution of exchanges so far as this country is concerned. This work has been carried on between the United States and each of these countries from the beginning at the expense of the Institution, which has paid all expenses, even to the employing of a salaried agent in both countries. As yet no definite action has been taken by either Government.

Although subsequently to the conclusion of the Brussels treaty in 1886, France had established an international exchange bureau, it had not provided sufficient means to conduct it in a manner to insure prompt distribution of parcels. The Secretary, accompanied by Mr. Henry Vignaud, of the United States embassy, had an interview with Monsieur Liard, chief of the libraries of France, who promised to recommend to the French Chambers an increase in the appropriation for international exchanges. The Secretary is pleased to note that a substantial improvement has recently been made in the time required for the distribution of exchanges in France, and has every reason to hope that the interests of the exchange service at large are about to benefit by improvements introduced at his request, on the efficient recommendation of M. Liard, in the French system.

Whenever it has been possible for a representative of the Smithsonian Institution to visit the exchange bureaus of other countries, the information obtained concerning the systems and customs practiced elsewhere and a personal acquaintance with the officers in immediate charge of exchanges has been of great benefit. As the official exchange bureaus of Italy and Switzerland had never been visited by a representative of the Institution, and as the agencies at Vienna and Budapest had not been inspected since the autumn of 1897, Mr. W. Irving Adams, chief clerk of the International Exchange Service, was directed to visit and familiarize himself with all of them during the last summer. His report, given in the Appendix, conveys the assurance that the cordial relations hitherto existing between these agencies and the Smithsonian Institution will henceforth be more firmly established than ever; and an increase in the contributions from Italy and Switzerland to the United States Government institutions, especially to the Library of Congress, is already apparent.

### NECROLOGY.

WILLIAM LYNE WILSON.

At a meeting of the Board of Regents of the Smithsonian Institution held January 23, 1901, the Hon. J. B. Henderson, the chairman of the Executive Committee, made the following remarks in memory of Mr. Wilson:

It is due to Mr. Wilson that a word of tribute to his memory should come from the Executive Committee of the Board of Regents. His service as a member of the Committee was of short duration, but long enough to endear him to those who survive.

While Mr. Wilson possessed, in an eminent degree, the power of speech—while indeed he was an orator, gifted with the charm and beauty of genuine eloquence—his chief title to remembrance will rest, not upon his words, but rather upon what he did and what he was.

*Non opus est verbis, credite rebus.* Blessed with a liberal education, he enjoyed it not alone, but became an educator of usefulness and marked distinction. As a lawyer he took high rank, and placed himself among the most distinguished jurists of his State. For twelve years he served an intelligent constituency in the Congress of the United States, where his record is marked by all that characterizes the highest order of statesmanship—honesty, purity, devotion, and intelligence.

As Postmaster-General in the Cabinet of President Cleveland, he gave renewed evidence of ability and industry, and

also the highest assurance of capacity for the conduct of the most difficult administrative duties.

With this but inadequate retrospect of what he did, let us turn for a moment to what he was. In the first place, he was what the poet justly designates as the "noblest work of God," an honest man. Beyond the wisdom of the philosophers and the classical lore of the universities, he had that pure and better teaching, an educated conscience. And to this unerring tribunal he submitted the conduct of his life. And thus it was that the observance of the golden rule brought him no burden, but was a part of his existence. He esteemed his friend as he esteemed himself. In the language of the Greek philosopher, his friend was "another I."

It has been said that great men are without ostentation and selfish pride. If this be a mark of greatness, Mr. Wilson's gentleness and simplicity of character gave him the highest place among the truly great. It is said, and said with truth, that kindness is the only key with which the casket of the human heart can be opened. Mr. Wilson had no enemies, and his kindness and lovable character explain the fact.

Tennyson was right when he said,

'Tis only noble to be good.  
Kind hearts are more than coronets,  
And simple faith than Norman blood.

The Board adopted the following resolutions.

Whereas the Board of Regents of the Smithsonian Institution is called upon to mourn the death, on October 17, 1900, of William Lyne Wilson, a member of the board from 1884 to 1888 and from 1896, and a member of its executive committee:

*Be it resolved,* That the Regents place upon record the expression of their sense of loss in the passing away of a colleague, the simplicity and integrity of whose life gave to the country a statesman of the first rank and to the people a noble example. To the Institution he brought the twofold qualities of the man of affairs and the man of learning, while his attention to his duties was unremitting, even in sickness, and his counsel was always most wise and helpful. As a college president, as a leader in Congress, he was conspicuous for his fidelity to the highest ideals. In his death the country has lost a distinguished citizen, the Institution a wise counselor, and the members of the board a colleague and friend, whose especially lovable nature won the hearts of all with whom he came in contact.

*Resolved,* That this resolution be entered as a part of the journal of the board and a copy transmitted to Mrs. Wilson.

Respectfully submitted.

S. P. LANGLEY,  
*Secretary of the Smithsonian Institution.*

## APPENDIX TO THE SECRETARY'S REPORT.

### APPENDIX I.

#### REPORT ON THE UNITED STATES NATIONAL MUSEUM.

SIR: I have the honor to report as follows regarding the condition and operations of the National Museum during the year ending June 30, 1901:

While having as its primary function to preserve and classify the Government collections, to which large additions were made during the year, the National Museum is best known to the public from its educational side, and as a source of information on scientific subjects. As one of the principal points of interest at the national capital, it is visited by large numbers of persons from all parts of the country, the attendance during the past year having been above 216,000, which is about the average. Many thousands who have not the opportunity of coming to Washington are benefited by its publications sent to them directly or accessible in the public libraries. Upward of 700 lots of specimens were received at the Museum for identification and report, besides some 8,000 letters requesting information on a great diversity of scientific topics. The amount of duplicate material contributed to educational establishments, large and small, in various parts of the country, and used in connection with the exchanges, has aggregated over 10,000 objects. At the close of the year scarcely any of the regular educational sets of duplicates remained on hand, but a new series of 100 sets of marine invertebrates was in course of preparation. It has also been possible to grant facilities to many students for conducting investigations along their special lines of research, and to others material has been sent as loans, to enable them to carry on their work at their home laboratories.

One of the most noteworthy accomplishments of the year has been the fitting up, under the direction of the Secretary, for the special benefit of very young people, of the main floor of the south tower of the Smithsonian building, adjacent to the Bird Hall, which has been designated the Children's Room. The floor is of marble mosaic, with a border of Celtic design. The walls have been painted in several shades of green and paneled, with a view of some time adding pictures illustrating curious features of animal and plant life. The ceiling is decorated with a trellis and vine, through which are glimpses of sky and cloud, and of bright-plumaged birds.

The main exhibition consists of strange and attractive specimens of birds, mammals, insects, shellfish, sponges, corals, minerals, and fossils, and occupies two cases surrounding the room and built so low that even the smallest child can examine the objects on the upper shelves. In the center of the room is a large aquarium with fresh-water fishes, while hanging from the ceiling are several brass cages with bright colored and singing birds.

The object in planning this room has been to excite the wonder and curiosity of children, to inspire them unconsciously with a love for nature, and no feature has been admitted which might tend to defeat this purpose. No Latin or technical labels puzzle the children, but every object is described in the plainest language.

*Organization and staff.*—The organization of the Museum, as modified in 1897, comprises an administrative office and the three scientific departments of anthropology, biology, and geology. Each department is in charge of a head curator and is composed of several divisions, of which anthropology has 8, biology 9, and geology 3, while there are also 18 subdivisions or sections.

Under the general direction of the Secretary, who is the keeper ex officio of the Museum, administrative matters have been in the immediate charge of the Assistant Secretary of the Smithsonian Institution.

At the close of the year the scientific staff consisted, besides the 3 head curators, of 18 curators, 12 assistant curators, 14 custodians, 10 aids, 4 associates, and 2 collaborators, making a total of 63 persons, of whom, however, only about one-half were under salary from the Museum, the remainder serving in a volunteer or honorary capacity, though nearly all of the latter were in the employ of other bureaus of the Government.

The Museum has suffered the loss of one of its most valued collaborators in the death, on September 15, 1900, of Mr. S. R. Koehler, Honorary Curator of the Section of Graphic Arts, who since 1887 had rendered most important services in building up the extensive print collection. He was also connected with the Boston Museum of Fine Arts as curator of prints.

Dr. W. L. Ralph, custodian of the Section of Birds' Eggs since the death of Maj. Charles Bendire, has been made Honorary Curator of that section, and besides giving generously of his time, he has, by liberal personal donations, greatly increased the size and value of the interesting collections under his charge. Mr. F. A. Lucas, curator of Comparative Anatomy, has been designated Acting Curator of Vertebrate Fossils. Miss Harriet Richardson has been made a collaborator in the Division of Marine Invertebrates, and Mr. Peter Fireman has received a temporary appointment as chemical geologist.

*Buildings.*—Attention has been directed in each succeeding report to the crowded condition of the two main buildings occupied by the Museum collections, and to the necessity of increasing from year to year the extent of the outside quarters required for storage and workshop purposes. During the past year Congress has again been called upon to provide for the rental of an additional building. Inconvenient as it is to administer upon the collections scattered and stored in this manner, the essential point is the danger to which the material is thus subjected—material which can not be replaced and which constitutes a record of the greatest importance to the Government archives.

Among the alterations and improvements made in the Museum building, the most noteworthy has been the fitting up of a new lecture hall in accordance with the provision of Congress, the room selected for the purpose being the East North Range, at one side of the main entrance. The only changes made in the room itself have been to substitute a terrazzo floor



for the old wooden one and to paint the walls and ceiling, which has been done in very tasteful and pleasing colors. The furnishings consist of the necessary platform, chairs, lantern, curtain, and stand, and adjustable screens at the windows. It is expected that the facilities thus afforded will often be utilized for the delivery of scientific lectures bearing upon the rich and varied collections in the Museum.

Some years ago a number of electric arc lamps were temporarily installed in the Museum building, the only attempt that had been made up to the present time to light its exhibition halls. The sundry civil appropriation act for 1901 carried an item of \$3,500 for beginning a permanent installation of wires for lighting the entire building. This work is now well under way and will be completed during the next fiscal year under an additional appropriation sufficient to cover the small wiring and the purchase of the necessary fixtures and lamps.

The roof of the Museum building, never entirely satisfactory, and showing many weak points during recent years, has been repaired and strengthened to the extent that its character warranted, under the advice of a competent engineer, and it is hoped that it can be made to answer for a few years longer.

It is noted with pleasure that the last of the wooden floors, with which, through motives of economy, the Museum was originally provided, have finally given place to a more substantial character of pavement. In anticipation of the appropriation made at the last session of Congress for improving the heating system, plans have been prepared for the installation of a pair of more powerful boilers, sufficient for supplying steam to both buildings, whereby it is expected to obtain a more reliable and economical service.

The furniture acquired during the year consisted of nine exhibition and 45 storage cases, besides 578 other pieces of furnishings.

*Additions to the collections.*—The new material received embraces 1,470 separate accessions, including about 180,000 specimens, and a census of the collections at the end of the year shows a total of about 4,995,000 specimens now catalogued in the Museum books.

The Department of Anthropology has received several collections of interest: From the Indian tribes of the Great Plains and the Interior Basin material of ethnological importance was obtained, consisting of articles of dress, implements, products of industry, and weapons, gathered by Capt. Paul B. Carter, U. S. A. A series of ethnological and archaeological objects was collected from the Mission Indians of southern California by Mr. Horatio N. Rust, with the special view of aiding the Museum ethnologists in distinguishing between the arts and industries of the Indians belonging to the Shoshonean and Yuman missions, and it therefore becomes a type of southern Californian material already in the Museum. About 150 specimens of costume, implements, utensils, and products of the primitive manufactures of the Chilkat Indians in southeastern Alaska were secured by Lieut. G. T. Emmons, U. S. N., and they have been largely used in preparing lay figures, constituting a family group of this tribe. To students of aboriginal American culture a series of seven facsimile reproductions of ancient Mexican colices, or books, presented by the Duc de Loubat, will furnish valuable information.

The anthropological department has likewise been enriched by material relating to South American tribes. Thus, through the courtesy of Dr. Orville A. Derby, director of the Geographical and Geological Survey of Sao Paulo, Brazil, Rev. W. A. Cook collected for the Museum a large number of ethnological objects from the Bororo Indians of Mato Grosso. These Indians belong to the extended South American family, the Tupi-Guarani, and their primitive mode of life as well as the picturesqueness of their feather costumes and ornaments give a special importance to the collection, coming from an area hitherto but meagerly represented in the Museum.

Material of the same general character was gathered by Prof. J. B. Steere, of Ann Arbor, Mich., from the Pamamary Indians and other tribes about the Upper Purus River in Brazil. The word "Pamamary" signifies "berry eaters," and as Professor Steere made a special study of these people on account of their wild habit of life, the objects have special worth in the series of industrial products. These Indians have not been classified linguistically, but form an outstanding group. Through an exchange with the Field Columbian Museum there was secured a selection from the ethnological material pertaining to the various tribes on the Upper Paraguay River exhibited by Dr. Emil Hassler and the Brazilian Commission at the World's Columbian Exposition in 1893. These are chiefly articles of dress gorgeously decorated with feathers, the savages of that region being very fond of arraying themselves with feathers of most brilliant colors. There are also numerous specimens of textiles. The tribes represented by this large and varied collection are the Apiaca (Tupian), Angaytes, Cadoca (Guaycurian), Cainguas, Chamacoco Brabos, Chamacoco Manos, Cordovas, Cuximanapanas, Guanias (Arawakan), Guaranis (Tupian), Guatos (Tapuyan), Lenguas (Lenguan), Matacos (Matacoan), Omiris, Parecis (Arawakan), and Payaguas (Payaguan).

Some interesting ethnological objects from California, Alaska, Hawaii, and the Fiji Islands were secured during the year, including various implements and utensils illustrating the early tribes of the Pacific coast; and especially conspicuous among them is a series of obsidian implements of remarkable size and execution.

From Miss M. A. Shufeldt, of Morristown, N. J., the Museum has obtained a series of ethnological material from China, Japan, and Korea, associated with historical events in which her father, Admiral Robert W. Shufeldt, U. S. N., played an important part, many of the objects being of considerable extrinsic value as well as of historical interest.

Among the objects received during the year from the Philippine Islands may be mentioned those presented by Gen. James M. Bell, U. S. V., which include three pieces of Bicol armor, a signal torch, several spears, bows and arrows, a war club, and a shield. Dr. W. L. Abbott, who for so many years has enriched the Museum with the results of his extensive explorations in the East, has now contributed a large and varied ethnological collection from the Andaman and Nicobar islands, a particular interest attaching to these groups for the reason that the inhabitants, especially those of the Andamans, are among the most primitive of mankind. These people belong to the "Negritos," or small negroids of south-eastern Asia, and are allied to the Semangs of the Malayau peninsula and

the Aetas of the Philippines. Dr. Abbott's collections are therefore very valuable, since they represent some of the very earliest stages of invention.

Two altars in combined Gothic, Renaissance, and Rococo style from a church in Hildesheim, Germany, have been added to the series illustrating ecclesiastical art, which it is hoped will be prepared for exhibition before very long.

The American history collections have been considerably increased during the year, perhaps the most noteworthy additions being swords, pistols, medals, spurs, and shoulder straps contributed by Mrs. George W. Morgan as personal memorials of her husband, General Morgan, who received them in recognition of his services in the Mexican and civil wars. Several telegraph instruments and insulators of historic interest were donated by J. H. Bunnell & Co., of New York City, and one of the original cylinders and other parts of the celebrated locomotive, the "Stourbridge Lion," were presented by Mr. G. T. Slade, general manager of the Erie and Wyoming Valley Railroad Company.

In the division of prehistoric archaeology 281 articles of flint from an ancient Egyptian quarry, presented by Mr. H. W. Seton-Karr, of London, are of special interest as illustrative of the quarrying and stone-shaping art of the primitive Egyptians. The specimens consist entirely of "rejectage," or partially shaped failures and broken pieces that result from the manufacture of knives and other implements by the flaking processes, and closely resemble the rejectage from American flint quarry sites. A number of Babylonian seals and some inscribed earthenware bowls were acquired during the year, many of the seals being rare and of great interest, while the inscribed bowls are said to reveal a peculiar phase in the development of religious ideas.

Among the accessions of prehistoric objects from localities within the United States may be mentioned as of special interest the stone implements and other relics, principally from Maryland, presented by Mr. J. D. McGuire, of Ellicott City, Maryland, consisting of more than 7,000 specimens, and perhaps the most important collection yet made in the Chesapeake region as the result of the energies of one person. Also there was acquired the Steiner series of more than 18,000 stone implements obtained from an ancient village site on Big Kiokee Creek, Columbia County, Georgia. Mr. Wm. H. Holmes, the head curator of the Department of Anthropology, secured nearly 500 archaeological specimens from an ancient quarry in Union County, Illinois. He describes these objects as representing not only the rejected materials resulting from manufacture, including the various forms of unfinished and broken implements and the flakage, but also the tools used in quarrying and shaping, and in sharpening the implements used and made.

In the Department of Biology several divisions report the receipt of accessions equaling or surpassing in interest and value those of the preceding year. One of the most important accessions was from Dr. W. L. Abbott, and included large numbers of mammals, birds, reptiles, mollusks, insects, and marine invertebrates from the Natuna Islands, the Mergui Archipelago, and the coast of Tringanu, Malay Peninsula. The value of this material will be appreciated from the fact that as many as twenty new species have already been noted among the mammals alone. The collections of

Dr. E. A. Mearns were also important, being largely from type localities along the Kissimee River and elsewhere in Florida, and comprised 600 birds and 300 mammals, besides birds' eggs and reptiles, and also a fine series of the skulls and skeletons of the soft-shelled turtle, *Platypteltis spinifer*. He also contributed a series of the mammals occurring in Rhode Island.

Six important lots of marine invertebrates were transferred to the Museum by the United States Fish Commission, namely: the Ophiurans of the Agassiz-*Albatross* cruise of 1891 to the Galapagos Islands and the west coast of Central America; the Japanese crustaceans collected by the *Albatross* in 1900; the corals obtained during the South Sea Expedition of the same vessel in 1899-1900; a collection of crayfishes from West Virginia; the crustaceans and echinoderms obtained by the Princeton University Arctic Expedition of 1899, and the corals gathered in Porto Rican waters by the steamer *Fish Hawk* in 1899. The Fish Commission has also deposited in the Museum the types of the new species of fishes collected on this latter expedition.

A valuable series of types of Hawaiian fishes collected by Dr. O. P. Jenkins, of the Leland Stanford Junior University, and Mr. T. I. Wood, has been contributed by the former, while the university presented an interesting collection of Japanese fishes.

Oriental shells, representing about 500 species and regarded as the most interesting addition to the Division of Mollusks, were received from Dr. W. Eastlake, of Tokyo, Japan. A collection of the shells of Haiti and Jamaica, embracing over 200 species, was gathered by Mr. J. B. Henderson, jr., of Washington, District of Columbia, and Mr. Charles T. Simpson, of the National Museum, Mr. Henderson generously paying the expenses of the trip. Some Naiades from Central and South America were received from Dr. H. von Ihering, of Sao Paulo, Brazil, and are of special value as supplying many deficiencies in the Museum collections.

The Museum has been fortunate in acquiring the private collection of Mr. Robert Ridgway, curator of the Division of Birds, representing about 1,100 species of North and Central American birds, many of them in the first plumages, and all in an exceedingly fine state of preservation. A representative series of 56 birds from Singapore has been donated by Mr. C. B. Kloss, and an excellent collection of the nest and eggs of Philippine birds, accompanied in many instances by specimens of the birds themselves, has been presented by Capt. H. C. Benson, U. S. A. Four Birds of Paradise, including the rare *Pteridophora alberti*, a species with extraordinary plumes, were also secured. Dr. W. L. Ralph has added to his many acts of generosity by donating rare birds' eggs, including specimens of the eggs of the Everglade Kite and Henslow's Sparrow.

The Division of Insects received several important accessions, the most noteworthy of which includes more than 15,000 specimens of European lepidoptera, a collection which was once the property of the late Dr. O. Hofmann.

The National Herbarium has been enriched by the acquisition of the collection of lichens belonging to the late Henry H. Willey, of New Bedford, Massachusetts, a well-known specialist in this group of plants; also of collections of 917 plants from Georgia, 617 from Missouri, 500 from

Florida, and 813 from Mississippi and Florida. Messrs. William Palmer and J. H. Riley, of the National Museum, gathered more than 300 plants in Cuba, while Messrs. C. L. Pollard and W. R. Maxon, attached to the botanical staff of the Museum, secured at least 1,600 specimens in Alabama, Georgia, and Tennessee.

All the divisions in the Department of Geology have received important additions, the Geological Survey, as in past years, being one of the principal contributors. Among the material transmitted by the Survey was a type series of 386 specimens of asphalt and associated rocks, collected in various parts of the United States by Mr. G. H. Eldridge, as well as some rocks and ores from the Ten Mile District, and Silverton, Pikes Peak, and Cripple Creek quadrangles, Colorado.

From the Geological Survey the following valuable collections of fossils have also been received: Three hundred and seventy-five specimens of pre-Cambrian invertebrate fossils, including species figured and described by the Director of the Survey, Dr. Charles D. Walcott, in the Bulletin of the Geological Society of America; a collection of 2,370 specimens from the Cambrian, consisting mainly of brachiopods; 2,425 Ordovician fossils from southern Nevada and near El Paso, Texas, and 114 Silurian and 1,550 Devonian specimens from the Helderberg and Oriskany beds of Indian Territory and the higher Devonian of Colorado and New Mexico. A portion of the material last mentioned was described by Dr. George H. Girty in the Nineteenth Annual Report of the Survey. Mention should also be made of the receipt of large collections of Cambrian fossils from Russia, Norway, Sweden, Nova Scotia, and Newfoundland, obtained for the Museum by Dr. Walcott and his assistants, Mr. M. Schmalensee and Mr. S. Ward Loper. Mr. Schuchert, of the National Museum, made extensive collections of Carboniferous, Silurian, and Devonian fossils in New Brunswick, the Gaspé region in Quebec, western New York, Maryland, and eastern Pennsylvania.

An excellent collection of cephalopod mollusks was acquired during the year, and a remarkably fine slab of crinoid, *Uintacrinus socialis*, from the Upper Cretaceous of Logan County, Kansas, was presented by Mr. Frank Springer, of Las Vegas, New Mexico. There was also secured the Randall collection containing upward of 3,600 specimens of Upper Devonian and Lower Carboniferous fossils. A fairly complete skeleton of an adult female mastodon was excavated in Michigan for the Museum. The skull of an *Elotherium* and other vertebrate fossils from the Bad Lands of Dakota were presented by Dr. J. R. Walker, of the Pine Ridge Agency. A nearly complete, though composite, skeleton of the New Zealand *Emeus crassus* was purchased, and a series of Moa bones was acquired by exchange from F. W. Hutton, of New Zealand.

Several valuable lots of fossil plants were received in exchange. Thus, the University of Kansas transmitted 150 Carboniferous and Permian fossil plants; 173 plants from the Middle and Upper Miocene and the Upper Pliocene of Germany were received from the Natural Science Society of the Museum Senckenberg in Frankfurt, and a small series of fossil plants from the Triassic of York County, Pennsylvania, was transmitted by Prof. A. Wanner, of York, Pennsylvania.

The meteorite collection has been increased by purchase and through exchange more than in any previous year. One of the most important accessions was a stony meteorite weighing 2,049 grams, which fell at Felix, Alabama, in May, 1900. It was collected by Mr. J. W. Coleman and transmitted to the Museum by Mr. R. D. Sturtevant, of Augustine, Alabama.

Important donations of minerals were as follows:

A quantity of Georgia corundum in masses and crystals, by the International Emery Company, of Chester, Massachusetts; a series of zinc ores and associated minerals from Missouri, by Mr. F. W. Crosby; large specimens of mohawkite and domeykite, with native silver, from the Wolverine copper mine, Houghton County, Michigan, by Mr. Fred Smith; 6 nuggets of platinum from Trinity County, California, by the Welsbach Company, through its president, Mr. W. E. Barrows; a fine large nodule of priceite, by Mr. W. C. Lake, of Harbor, Oregon, and 12 specimens of turquoise and 2 of opal, by Mr. H. P. Petersen, of Washington, District of Columbia. Among other additions was a series of specimens of native silver and copper from Houghton County, Michigan, and 3 samples of beach gold from Cape Nome, Alaska.

*Exploration.*—Some of the most important accessions of the year were the results of explorations carried on by members of the Museum staff and by other scientific bureaus of the Government. Mention has already been made of several collections secured in this manner.

Mr. W. H. Holmes, head curator of Anthropology, accompanied by Dr. W. A. Phillips, of the Field Columbian Museum, examined the extensive flint quarries in the vicinity of Mill Creek, Union County, Illinois, where he obtained a large number of implements and quarry rejects. In June, 1901, Dr. Walter Hough began investigations in the Pueblo country in conjunction with Mr. Peter G. Gates, of Pasadena, California, intending to continue the work during the entire summer, chiefly at the expense of Mr. Gates, the collections to be divided between him and the National Museum. The collections made by Prof. J. B. Steere, of Ann Arbor, Michigan, on the Upper Purus River, in Brazil; by Mr. William A. Cook, near the headwaters of the Paraguay River, and by Lieut. G. T. Emmons, U. S. N., in British Columbia and Alaska, have already been referred to. The expeditions to the Philippines by Col. F. F. Hilder, and to Sonora, Mexico, by Mr. W. J. McGee, both of the Bureau of American Ethnology, for the Government board of the Pan-American Exposition, resulted very successfully, and the material obtained will, it is understood, be transferred to the Museum at the close of the exposition.

Dr. Roland Steiner continued his explorations of quarries, workshops, and village sites near Grovetown, Georgia, and at the mouth of Shoulderbone Creek and on Little Kiokee River, where he procured many thousands of specimens, all of which have been deposited in the Museum.

During a stay of four months in Florida, Dr. E. A. Mearns, U. S. A., gave his attention to the collecting of birds and mammals for the Museum. Mammals were also collected in Italy, Sicily, and southern France by Mr. Dane Coolidge, and in the vicinity of Peterboro, New York, by Mr. Gerrit S. Miller, jr. Mr. W. H. Ashmead was detailed in the spring of 1901 to obtain entomological material in the Hawaiian Islands, in conjunction with

an expedition sent there by the U. S. Fish Commission, and Dr. J. E. Benedict accompanied the Fish Commission steamer *Fish Hawk* during an exploration of the fishing banks in the Gulf of Mexico opposite Anclote River, Florida. Mr. J. B. Henderson, jr., of Washington, who has on many former occasions manifested his interest in the Museum, made at his own expense a collecting trip to Haiti and Jamaica, taking with him Mr. C. T. Simpson, of the Division of Mollusks. Much valuable molluscan material was obtained.

Messrs. Barton A. Bean and William H. King collected fishes at Key West, Fla. The explorations in Cuba for the Pan-American Exposition, begun in 1900 by Messrs. Palmer and Riley, also of the Museum staff, were completed early in the year. Botanical explorations with interesting results were conducted in the Southern States by Messrs. C. L. Pollard and W. R. Maxon.

Important accessions through explorations by the Geological Survey have already been alluded to. Mr. F. A. Lucas, of the Museum, and Mr. Alban Stewart visited several localities where mastodon bones had been reported, with the object of securing a skeleton for the Pan-American Exposition. Only a single fairly preserved one was obtained, however, in a locality in southern Michigan. Mr. Charles Schuchert spent considerable time collecting fossils in Canada, also in the vicinity of Buffalo, N. Y., in Maryland, and in eastern Pennsylvania, the object of his inquiries being to secure data for fixing more definitely the line separating the Silurian and Devonian systems in America.

*Exchanges.*—Much material had been received through the exchange of duplicate specimens with scientific establishments and individuals both at home and abroad. In view of the small amount of money available for purchases, this method of obtaining collections has become of considerable importance, especially with reference to foreign countries, from which gratuitous contributions are rarely to be expected and to which the scientific explorations of this Government seldom extend. Transactions of this character were conducted through the year with the following institutions and individuals abroad:

Royal Botanic Gardens, Kew, England; Museum of Natural History, Paris, France; Musée de St. Germain, Seine-et-Oise, France; Zoological Museum, Copenhagen, Denmark; Museum Senckenberg, Frankfort-on-the-Main, Germany; Royal Zoological and Anthropological-Ethnographical Museum, Dresden, Germany; Geological Institute of Kiel, Germany; Museum of Natural History, Berlin, Germany; Zoological Museum of the University of Upsala, Upsala, Sweden; Museum of the Imperial Academy of Sciences, St. Petersburg, Russia; Royal Geological Museum, Leiden, Holland; Royal Zoological Museum, Turin, Italy; Royal Botanic Gardens, Sibpur, India; Australian Museum, Sydney, New South Wales; Canterbury Museum, Christchurch, New Zealand; National Museum, Montevideo, Uruguay; Museu Paulista, Sao Paulo, Brazil; National Museum, Mexico, Mexico; Geological Institute, Mexico, Mexico; and with Mr. B. W. Priest, Keeppham, England; Mr. W. Kirkaldy, Wimbledon, England; Prof. Henry Balfour, Pitt Rivers Museum, Oxford, England; Mr. Edward Lovett, Croydon, England; Mr. C. T. Druery, London, England; Prof. M. Gandoger,

Anas (Rhone), Villefranche, France; Mr. E. Andre, Gray (Haute-Saone), France; Dr. Krantz, Bonn, Germany; Dr. E. Schellwien, Provinzial Museum, Königsberg, Prussia; Dr. Fred. Berwerth, Vienna, Austria; Mr. Carl Wohlgemuth, Bozen, Tyrol, Austria; Prof. W. C. Brögger, University of Christiania, Christiania, Norway; Mr. G. van Roon, Rotterdam, Holland; Mr. Paul Narbel, Cour, Lausanne, Switzerland; Dr. I. Comabella, Barcelona, Spain; Mr. W. R. Billings, Ottawa, Canada.

*Installation.*—The crowded condition of the two buildings occupied by the National Museum prevents any extensive advances in connection with either the exhibition or the working collection of specimens. Improvements are constantly being made in methods of installation, in labeling, and in the substitution of a better quality of specimens in the display cases whenever such are received, but the growth of the Museum in directions apparent to the public and the specialist has come practically to a standstill. There is room left only for storage.

One of the galleries allotted to the Department of Anthropology for exhibition purposes has of necessity been cut off from the public and made into a temporary laboratory. Considerable progress has been made in this department in the preparation of case labels. Some changes have been made in the section of Biblical Antiquities. The collections in the section of American history and certain exhibits in the division of Prehistoric Archeology have been largely rearranged.

The South East Range, assigned to the exhibition of reptiles, amphibians, and fishes, has been entirely renovated, a terrazzo floor having been laid and the walls and ceiling appropriately painted. The installation, however, is not yet completed. Casts of fishes now occupy upright cases along the west wall, while the reptiles and amphibians are shown in a series of floor cases with sloping tops. Some South American and Old World species in alcohol will shortly be added. A small series of deep-sea fishes, supplemented by colored figures, has been placed on exhibition. The exhibit of game birds in the entrance hall of the Smithsonian building is being entirely reconstructed, so as to illustrate, in groups, the parent and young birds in an environment characteristic of their haunts. At the close of the year four such groups had been finished. Owing to the imperfect condition of the cases in which the large regular series of birds is installed, it has been necessary to employ a taxidermist continuously in overhauling the collection, in order to preserve the specimens from deterioration. These cases, which have been in use for about twenty-five years, are now neither dust nor insect proof.

Perhaps the most important, or at least a most interesting work of installation completed during the year, is the Children's Room, mentioned on a previous page.

New labels have been prepared for the American mammals occupying the large wall-case on the east side of the South Hall, and a series of enlarged models, representing the structure of feathers, has been added to the collection in the Division of Comparative Anatomy.

The display collections of the Department of Geology were never in a more satisfactory condition than at present, and, except in the Sections of Paleobotany and Vertebrate Paleontology, they are well arranged and



labeled. There is on hand, however, a very large amount of original material, as represented in the Marsh collection of fossil vertebrates and the Lacey collection of fossil plants, which requires time for its preparation, but from which the exhibition halls will ultimately receive some of their most novel and interesting features.

*Publications.*—The publications issued during the year comprise the second volume of the Annual Report of the Museum for 1897, the Annual Reports for 1898 and 1899, Volume 22 of the Proceedings, and Part 1 of Special Bulletin No. 4, besides a large number of papers from the Reports and Proceedings printed in separate form.

Volume II of the Report for 1897 contains a biographical account of Dr. G. Brown Goode, the late Assistant Secretary of the Smithsonian Institution in charge of the National Museum, together with reprints of several of his more important papers on museums and on the history of scientific progress in America, and is illustrated with portraits of more than 100 men who have been prominent in the scientific advancement of the country. The Appendix to the Report for 1898 consists of a single paper by the late Prof. E. D. Cope on the crocodilians, lizards, and snakes of North America, comprising 1,100 pages of text, with 37 full-page plates and 347 text figures. The Report for 1899 contains five scientific papers based upon collections in the Museum.

Volume 22 of the Proceedings includes papers numbered from 1179 to 1205, the Synopsis of the Naiades, by Mr. Charles T. Simpson, being especially worthy of note.

Part 1 of Special Bulletin No. 4 is the first of a series of papers on the American Hydroids, by Mr. C. C. Nutting, professor of zoology in the University of Iowa, and was issued early in the fall. It treats of the Plumulariæ, is in quarto form, and contains 34 plates.

Dr. W. L. Ralph has undertaken to continue the extensive work on the Life Histories of North American Birds, begun some years ago by the late Maj. Charles E. Bendire, U. S. A., and of which two volumes have been printed as Special Bulletins Nos. 1 and 3, and a circular (No. 50) soliciting new and unpublished information on the subject has been prepared and distributed to correspondents.

*Pan-American Exposition.*—At this exposition, which opened at Buffalo on May 1, and will continue until the 1st of November, the three scientific departments of the Museum are represented by carefully prepared collections.

The exhibit in anthropology is intended to illustrate the native peoples of America from North Greenland to Terra del Fuego. It consists primarily of twelve groups of lay figures, each showing the several members of the family of a representative tribe engaged in some characteristic pursuit, and so arranged that in passing from one to the other the visitor may form an intelligent idea of the appearance, condition, and culture of the original inhabitants of the continent. There are also thirteen models illustrating various types of dwellings from the far North to the extreme South, and thirteen series illustrating those activities that seem best calculated to convey an idea of the culture status of the races.

The exhibit made by the Department of Biology is limited to American

vertebrates, and includes a number of large characteristic American animals, such as the Kodiak bear, glacier bear, Alaskan moose, white sheep, musk ox, West Indian seal, the condor, bald eagle, boa constrictor, alligator, Galapagos turtle, various large fishes, etc. Many of the specimens were obtained especially for this purpose, and all are exceptionally well prepared.

The Department of Geology is represented by a systematic collection of minerals, comprising 735 specimens; collections illustrating cave deposits, concretionary structures, hot springs and geyser deposits, silicified woods, and the rocks and soils of the Hawaiian Islands; a small case of native elements; a collection of 450 specimens illustrating the development and classification of the cephalopod mollusks, and a synoptic collection of crinoids, including about 300 specimens; a mounted skeleton of the gigantic toothed diver, *Hesperornis regalis*, from the Cretaceous of Kansas; a life-size restoration of the skeleton of the Cretaceous reptile, *Triceratops prorsus*, from the Cretaceous of Wyoming, and a life-size restoration of *Zeuglodon* from the Tertiary of Alabama. In addition there are two cases of bones of the mammoth from Indian Territory and Missouri.

*Library*—The additions to the library during the year numbered 1,038 books, 2,261 pamphlets, and 8,968 parts of periodicals.

Respectfully submitted.

RICHARD RATHBUN,  
*Assistant Secretary.*

Mr. S. P. LANGLEY,  
*Secretary, Smithsonian Institution.*  
AUGUST 1, 1901.

## APPENDIX II.

### REPORT OF THE BUREAU OF AMERICAN ETHNOLOGY.

SIR: I have the honor to ask attention to the following report of operations in the Bureau of American Ethnology during the fiscal year ending June 30, 1901.

These operations were conducted in accordance with the act of Congress making provision "for continuing researches relating to the American Indians under the direction of the Smithsonian Institution," approved June 6, 1900, and with the formal plan submitted on June 9, 1900, and approved by the Secretary on June 19, 1900.

The field operations of the regular corps extended into Arizona, Lower California (Mexico), British Columbia, California, Maine, New Mexico, New York, North Carolina, Ontario, Sonora (Mexico), Virginia, and Wisconsin; while special work has been carried forward by agents or temporary collaborators in several additional States, Territories, and provinces. The office work has comprised the collection and preparation of material from most of the States and Territories, as well as from various other parts of the American hemisphere.

The researches have been carried forward in accordance with an ethnic system based chiefly on the work of the Bureau, though partly on the observations and determinations of other scientific investigators in this and other countries.

The ethnic system developed and adopted in the Bureau is based primarily on the human activities—i. e., on what men do and think—rather than on mere physical features. Proceeding on this basis, the habits and customs of the aborigines receive first attention; and the tribesmen are classed by their languages and dialects, by their forms of social organization, by their systems of belief and opinion, by their arts and industries; so that the classification affords a means of measuring the susceptibility of the various tribes to civilization, to education, and to arrangement on reservations in harmonious groups. The classification is thus essentially practical.

The practical tribal classification rests on a definition of the activities discovered among the aborigines and other peoples largely during the past quarter century. The primary activities thus discovered are esthetic; and intimately connected with these are the industrial activities involved in maintenance and welfare. Equally important are the social activities shaping the collective existence of families, clans, tribes, and confederacies; and the relations are regulated by linguistic activities, which are highly important and indeed fundamental. Coordinate with these activi-

ties of arts and industries, laws and languages, are the activities connected with opinion, belief, philosophy—i. e., the sophic activities. On weighing all the factors it has been found that the most convenient classification of tribes is that based primarily on language, as explained in previous reports; and this mode of defining the Indian tribes, first proposed by Gallatin and adopted by the Bureau on its institution, has now come into general use.

#### FIELD RESEARCH AND EXPLORATION.

Throughout the first quarter of the year the Director was in Maine, reviewing observations on shell mounds and village sites in connection with the researches in classification noted in other paragraphs; and the work was resumed early in June. Limited collections were made, though the observations and notes on the numerous survivors of the Abnaki Indians proved of much interest and value.

An extended exploratory trip was made during the autumn of 1900 by Mr. McGee. Early in October he proceeded to the field for the purpose of completing researches relating to the aborigines of the Serian stock and at the same time carrying forward studies of neighboring tribes. A party was organized at Phoenix, Ariz., and moved southwestward to Gila Bend and thence southward to the international frontier at Santo Domingo. Here the outfit was admitted to Mexican territory through the courtesy of Señor Don Fernando Leal, at the obliging instance of Señor Don Manuel de Aspiroz, the ambassador from Mexico to the United States. In this vicinity are several settlements of Papago Indians, including some of the Areneños of early literature and local tradition, and the opportunities for study were seized. From Santo Domingo the party proceeded southward to Caborca and thence westward to the coast of Gulf of California, where the Tepoka Indians (collinguals of the Seri) were reported to live so late as 1894, subsisting on sea food and finding potable water in the lagoons and sand beds at the embouchure of the sand wash variously called Magdalena, Santa Ana, Altar, Asuncion, and San Ignacio. On reaching the coast the leader was disappointed to find the tribal remnant entirely gone—probably through extinction, possibly through migration down the coast to Seriland. Traces of the Tepoka habitations still remained, together with shell accumulations and minor relics, corroborating the reports concerning the tribe current at Caborca in 1894; and the visit served also to clear up doubtful points connected with the geography and history of the region. Failing thus to attain the primary object of the expedition, Mr. McGee determined to visit the territory of the little-known Cocopa Indians, reputed to live about the head of the gulf, and to this end endeavored to follow the coast northward to the mouth of the Colorado. Finding this entirely impracticable, he returned by a new route to Santo Domingo, collecting useful data concerning the Papago Indians on the way; and from Santo Domingo he proceeded west-northwestward over the old Yuma trail (including a stretch of 90 miles now without water) to Yuma, and thence southward to the Cocopa country. Here valuable collections, notes, and photographs were obtained; and after some weeks the party returned via Yuma and the Gila and Salado valleys to Phoenix, disbanding there on December '20. The party comprised Mr. W J McGee, ethnologist in



SIoux FAMILY, IOWA TRIBE. AH-BLOH-COE-WAH-YE (STANDING ON PRAIRIE), ALIAS JOHN GRANT, CHIEF, 1900.



charge, as leader; Mr. DeLancey Gill, artist; Prof. R. H. Forbes, of the Territorial University of Arizona (during part of the trip); Señor Aurelio Mata, a Mexican customs officer sent from the custom-house at Nogales to facilitate the crossing at the international boundary; John J. Carroll, of Tempe, teamster; Jim Moberly, of Tempe, packer; Hugh Norris, of Tucson, Papago interpreter, and Ramon Zapeda, of Tucson, Mexican interpreter. The Bureau was placed under great obligations for free entry of the outfit to the Government of the neighboring Republic through the officials already named, as well as through Señor Don Eduardo J. Andrade, of Yuma, custodian of the Andrade grant, covering the territory occupied by the Cocopa Indians.

On August 11 Mr. James Mooney proceeded to the old Cherokee country in western North Carolina and adjacent territory for the purpose of collecting additional data required for the completion of his series of papers on the Cherokee Indians, and his field operations continued with success until early December. On April 25 he made a reconnoissance trip through eastern North Carolina and Virginia for the purpose of locating remnants of aboriginal tribes still surviving in the wooded and nearly inaccessible districts of that region; he revisited the Pamunkey tribe and discovered considerable remnants of the Chickahominy, Mattaponi, and Nansemond tribes.

On his appointment as assistant ethnologist (September 1), Mr. John R. Swanton proceeded to British Columbia to undertake researches among several northwestern tribes. His work proceeded successfully up to the end of the fiscal year, when he was still in the field.

On October 1 Mr. J. N. B. Hewitt repaired to the region occupied by the survivors of the Iroquoian tribes in northwestern New York and neighboring portions of Canada, where he began the collection and verification of traditions and cosmogonic legends, and his work continued until about the middle of February, when he returned to the office with valuable collections and records.

On April 15 Dr. Frank Russell was appointed as ethnologist and was assigned to duty in Arizona; he immediately proceeded to the field and began an extended reconnoissance of the southern and central portions of the Territory. Outfitting with a team at Tucson, he passed around the northern end of Santa Catalina Mountains and up San Pedro River (visiting the caves and pictographs of the Santa Catalina range and the cliff houses of the Galiuro range on the way) to Nugents Pass, where he entered Aravaipa Valley. Here he found an interesting group of cliff houses. Thence he proceeded, by way of Eagle Pass, to Gila Valley, where interesting archeologic observations were made. Pushing on southward he traversed the eastern slopes of Chiricahua Mountains and the western slopes of Swisshelm Mountains, and examined the easterly canyons of Huachuca Mountains. Next he traversed portions of the Babacomori, Sonoyta, and San Rafael valleys about the Mexican boundary; thence he returned by new routes to Santa Catalina Mountains and Tucson, arriving about the end of May. In the course of the trip he discovered various ruins hitherto unknown, some of new types. Several of the ruins were surveyed, and limited collections were made. On June 11 he proceeded

northward from Tucson, crossing the Gila near Florence, skirting the base of Superstition Mountains, and traversing Tonto Valley; a number of cliff houses and other ruins were discovered, but the journey was not completed at the end of the fiscal year.

In June an arrangement was effected with Mr. O. P. Phillips and the Armat Moving-Picture Company, under which Mr. Phillips proceeded to New Mexico and Arizona for the purpose of making motion pictures representing the industries, amusements, and ceremonies of the Pueblo and other tribes, it being anticipated that such pictures would prove of especial service for purposes of immediate research as well as for permanent record. The preliminary reports indicate that the work has been successfully initiated.

Throughout the fiscal year Dr. Willis E. Everett remained in Alaska, pursuing his avocation of mining engineer, but availing himself of opportunities for observing the native tribes and recording their languages and other activital characteristics. Several reports indicating progress in the collection of such material were received in the course of the year.

Dr. Robert Stein, who spent the winter of 1899-1900 on Elsmderland, primarily for purposes of geographic exploration, but incidentally to make search for traces of aboriginal occupany in the interests of the Bureau, reported via Dundee, through the courtesy of masters of whaling vessels, late in the summer of 1900. He found no traces of Eskimo or other settlements in the territory traversed by him, comprising the eastern coast of Elsmderland, and his negative evidence is of service in investigations relating to the distribution and migrations of the Eskimo. At the time of the last report he was preparing to cross Baffin Bay to Upernivik, on the western coast of Greenland, with the expectation of extending his previous observations on prehistoric Eskimo settlements along the unexplored coast.

During the autumn Miss Alice C. Fletcher found it necessary to revisit Oklahoma for the purpose of completing the ritual of the Pawnee ceremony, known as the Hako, of which the greater portion was collected during the last fiscal year. In connection with the collection of this material she was fortunate in obtaining also much additional information touching the ceremonial and ritualistic life of this highly interesting and little-studied tribe.

#### OFFICE RESEARCH.

##### WORK IN ESTHETOLOGY.

In addition to administrative duties in the office and the field work noted, Mr. McGee engaged in researches relating to the primitive symbolism found among the American aborigines and other lowly peoples. Certain symbols are of nearly world-wide distribution, and extend into several stages of culture—e. g., the swastika, or fylfot, appears on all of the continents except Australia, and its culture range extends at least from higher savagery into the lower strata of civilization. Before the extremely wide range of such symbols was ascertained various inquirers were led to regard the swastika as an evidence of cultural identity, and hence of the original



unity of the peoples among whom they were found; but since they have been observed among highly diverse peoples in different stages of culture and on remote continents this interpretation has been modified or abandoned in large measure, and students have set themselves to the task of tracing the development of the symbols in particular cases. The recent researches have shown that the symbols of quatern character, like the swastika, express or reflect modes of thought especially characteristic of lower (but not lowest) culture, yet extend well into civilization and enlightenment. At the same time the researches bring to light such diversities in the nature and applications of the concepts expressed by the symbols as to indicate, if not demonstrate, independent development. Thus, quatern symbols abound among the Papago Indians of Arizona and Sonora, as well as among several neighboring tribes, yet the Papago concept is distinct, as shown by its extension to time as well as space, this extension carrying such archaic features of ritual and ceremony as to indicate increasing independence of the concept in the generations traced backward. The neighboring Zuñi Indians have a more highly differentiated concept, e. g., in that their "cult of the quarters" involves six directions (zenith and nadir in addition to the cardinal points), yet the symbol retains the original quatern form, with two added elements so placed as to destroy the symmetry of the figure. These instances of diversity in symbol, and still greater diversity in meaning of the symbol (or in the primary concept), might be multiplied almost indefinitely; they merely give some indication of the development of simple Lbf=F quatern symbols and of the complex and protean magna of thought out of which they have been developed by simple processes and in easy steps. Incidentally the examples marshaled by Mr. McGee corroborate and extend the law of actualival coincidences formulated in an early report of the Bureau; but the applications of the recent study are numerous and useful, especially in their bearing on symbolism in general and on the development of systems of counting. The results of the study are incorporated in the Nineteenth Report in the form of a brief paper entitled "Primitive numbers."

During the earlier portion of the year Dr. Fewkes arranged for publication a series of graphic representations of the personages composing the Hopi pantheon, together with full descriptions of the pictures and a discussion of characteristic paraphernalia of the personages represented. The representations are in outline and color and well illustrate the early stage in the development of graphic art reached by the more advanced among the aboriginal tribes; hence they throw strong light on the codices and other pictorial essays of the more southerly tribes, especially those of Mexico, Central America, and Peru. The pictures were executed by a native artist, who was also a priest in the hieratic or sacred organization through which the tribal mythology is maintained, and each picture is a faithful reproduction of ancient representations handed down through many generations. The material has been assigned for publication in the twentieth annual report; the original drawings will be used as copy and will be reproduced in slightly reduced facsimile. The work is deemed an important contribution to knowledge of the aborigines in several respects. It illustrates the motives and conventions of aboriginal art in both form and color; it

reveals the rôle of symbolism in primitive art with remarkable clearness; it illustrates with satisfactory completeness the nature and structure of a typical barbaric pantheon; and since the symbols and conventions (and, indeed, the personages represented) are of great constancy in primitive thought, it affords a series of types available for use in identification and comparison of a wide range of symbolic representations among the Pueblo and other tribes, not only in ceremonies and sacred paraphernalia, but in the decoration of fictile ware, basketry, woven fabrics, etc.

Later in the year Dr. Fewkes was occupied with a systematic study of the collections made by him in Arizona and New Mexico during 1896 and 1897, the study being carried forward with special reference to the symbolic decoration of the fictile ware. All systematic investigators of the decorative devices used by primitive peoples have been impressed with their constancy, i. e., with the exceeding slowness of modification. They have also been impressed with the dependence of the modification on external forces and conditions rather than on the spontaneous internal factor so prominent in the art of advanced culture. Recognizing these characteristics of primitive art, Dr. Fewkes undertook to define the symbolic (or esthetic) types prevailing among the peoples of Walpi, much as a naturalist might define types of animal and vegetal life for the establishment of species, genera, and orders, and for tracing the lines of vital development in a distinctive environment. His symbolic types were based on specimens observed among the tribesmen or obtained from sites by their ancestors during the historical period; and he soon found that the types served to indicate what may be termed a "symbolic province," i. e., a region throughout which the symbolic devices were similar, but in which they differed essentially from those of other regions. In this way he defined an ethnic district and established standards for the guidance of future investigation and also for the localization of ill-labeled specimens in museums; for many collectors have been content to label specimens of symbolic pottery, etc., "Arizona," "Pueblo region," or by other large and indefinite political or natural divisions, thereby confusing important symbolic distinctions and ethnic districts. As his investigations of the symbolic types progressed, Dr. Fewkes became more deeply impressed than any predecessor with the persistence of motives and the regularity of their evolutionary lines; and he conceived, in a definite and constructive way, the possibility of tracing prehistoric migrations by means of the decorative symbols, i. e., of employing symbolic devices as prehistoric records, reading from them the tale of tribal movements before the coming of Coronado. He conceived the possibility of coordinating the archeologic record as taught by symbols with tribal traditions, and the double advantage of mutual verification between tradition and symbolic record. Proceeding in accordance with these ideas, he obtained from living Hopi traditions of a former residence of their ancestors at a locality which they called Homolobi; and by excavations identified this site and verified the traditions, extending his knowledge of the evolution of the symbolic types; for the Homolobi collections (now in the National Museum) are not only abundant in decorated ware, but notably rich in symbols susceptible of interpretation. Subsequent exploration brought him to the site of a ruin on



SHAHAPTIAN FAMILY, NEZ PERCÉ TRIBE. CHIEF JOSEPH, 1900.



Cheylon Creek, where excavation revealed another stage in the same general line of symbolic development, which corroborated the vague and shadowy tradition that Hopi clans once inhabited this site. He later sought a locality noted in the vaguest of all the migration legends still current, and he was gratified by finding near Chavez Pass the archeologic record of this stage in migration inscribed in symbols related to the higher type from the more northerly localities. Beyond this point ruins which mark traditional halting places in migration were not located; beyond it the symbolic development has not yet been traced; but there is good ground for anticipating that when Dr. Fewkes resumes the field he will obtain still earlier records of the prehistoric movements and development of this branch of Pueblo peoples. The work is deemed of much importance as a verification of aboriginal tradition, as a means of verifying other migration legends, and as a most promising introduction to the practical interpretation of history unwittingly recorded in graphic symbols. Incidentally, the work corroborates the earlier conclusion reached in the Bureau, that the Pueblo peoples are a resultant product of Southern culture and Northern blood; yet the significant details throw new light on the entire problem. The report is elaborately illustrated by colored photographs of the ware from the several localities examined; it was practically ready for the press at the close of the fiscal year.

#### WORK IN TECHNOLOGY.

The earlier accounts of exploration in the territory occupied by the Cocopa Indians seemed to indicate that the tribesmen occupied the coast of Gulf of California and were of maritime habits; but in the course of the expedition led by Mr. McGee it was definitely ascertained that the folk are essentially agricultural and confined, at least so far as habitations are concerned, to the interior. The industrial condition of the tribe was found to be of much interest. The tribal habitat comprises the Lower Colorado Valley from the international boundary southward to the head of the gulf, together with a few tributary valleys descending from the Cocopa Mountains on the west. The main valley is broad and diversified by distributaries, or bayous, of which the most important is Hardy River, or "Hardy's Colorado." There are also several fairly permanent basins, filled by the annual floods and slowly evaporated during succeeding months, and the greater part of the broad bottom is swept by the freshets. Within the region lie a number of "mud volcanoes," apparently analogous to the "mud lumps" of the Lower Mississippi, which have attracted much attention by reason of their novelty, though they are quite subordinate to the general features. The entire district affords the closest American parallel to the valley of the Nile, not only in physical conditions, but in the influence of these on human conditions. Like northern Africa, the general region is one of extreme aridity, the rainfall (averaging less than 2 inches yearly during the last quarter century at the typical station of Mammoth Tanks) being negligible; while the habitable district is well watered by annual freshets of remarkable regularity in period and height. These freshets not only flood but fertilize the riparian lowlands; they control directly the local flora and somewhat less directly the local fauna,

and they regulate the movements, most of the industrial habits, many of the social customs, and much of the mythology of the human population. During the greater part of the year water is obtainable only from the shrunken river, on whose banks grow most of the seed-bearing and root-yielding plants available as food, so that the people are led to occupy the lower bottom lands. Here the cultivated crop plants are sown in soil soaked by the flood and enriched by its silt deposit, to grow and ripen rapidly under the subtropical sun; here habitations are erected, naturally of light and temporary character, and here the small and scattered villages characteristic of the tribe grow up during each late summer and early autumn. The chief crop plants are corn (maize), beans, peas, squashes, and melons, and it is noteworthy that most of these represent the aboriginal plant stocks brought under cultivation in pre-Columbian times. Fishing and hunting the abundant waterfowl, as well as other game, contribute to the tribal subsistence, and during recent years part of the corn, beans, and peas is carried on horseback to Yuma, where it is bartered chiefly for appareling. Early winter is the time for ceremony with the attendant feasting, and by early spring when the greater and less portable part of the annual crop is consumed, the families prepare for the annual migration to the higher lands, where they await the rise and subsidence of the vernal flood. On its passing they return to the low grounds, to rebuild and plant on the last year's farms or elsewhere according to the changes wrought by the freshet or the chance of death and mortuary observance. Naturally an agriculture depending so largely on chance conditions is improvident, comparatively unproductive, and incapable of sustaining any considerable or concentrated population, so that its tendency combines with that of annual migrations to stifle the home sense and to scatter the members of consanguineal groups and thus to affect the social organization. The recurrent floods also affect the ceremonies and attendant faiths of the tribesmen in various ways; e. g., they control mortuary observances and have undoubtedly led indirectly to the custom of burning the bodies of decedents in and with their houses, distributing their property to nonrelatives, and incidentally destroying adjacent houses and other property. This dispersive social factor combines with that growing directly out of the agricultural methods, and not only prevents the development of village life with the concomitant institutions, but perpetually impoverishes the tribe. Thus the Cocopa Indians present an industrial paradox, for while they occupy one of the garden spots of the Western Hemisphere, whose natural freshets might be so utilized as to sustain an enormous population, they subordinate themselves to the environmental conditions and remain one of the poorest and most hopeless of the American tribes.

During the earlier part of the year Dr. Albert E. Jenks (then a correspondent of the Bureau) revised his memoir on *The Wild Rice Gatherers of the Lake Region* (in press as part of the Nineteenth Annual Report, as noted in the last report), incorporating some of the results of recent researches. On June 1 he was appointed to the position of assistant ethnologist in the Bureau, and was assigned to work related to his previous researches. He at once took up the subject of birch bark, with the aboriginal industries depending on this natural commodity of a considerable fraction of the

North American continent. One of the most important products of the birch-bark industry is the canoe; and this, like other industrial products of consequence, exerted a powerful influence on the lives of the producers. Through one of those harmonics of nature on which the progress of mankind so largely depends, much of the birch-bearing region of North America (a zone stretching from Maine to Washington State and Alaska, and extending from below the Great Lakes nearly to the treeless Arctic) is also the region of late Pleistocene glaciation, and hence of glacial lakes, swamps, and labyrinthine streams; so that throughout the period of aboriginal development an ideal canoe material coexisted with illimitable functions for the canoe in the way of travel and transportation. Under the natural combination, joined to native intelligence and skill, the lakes and streams became routes of passage, and by reason of the lightness and strength of the material, and the lowness and narrowness of the ice-molded divides, portages were easy, so that the routes passed from lake to lake, river to river, and drainage system to drainage system, practically across the continent. Under the stimulus of facility the birch-canoe makers became travelers and explorers; energetic hunters and fishermen explored new waters and carried tribal knowledge into new regions; ambitious scions struck out into the remoter wilderness to make conquest over the unknown and often to establish families and clans, and eventually tribes, in new localities; so that in course of time the paddlers of the light canoe carried their kindred, their dialects, their faiths over the greater part of the vast region defined by the birch tree and the glacial waterways. Most of the canoe men belong to the Algonquian stock, most of the remainder to the Athapascan stock; and the recent researches render it clear that their water craft was a leading factor in determining their wide distribution, their success in making conquest of the continent up to the plane of aboriginal standards. The detail results of the work are in preparation for an early report.

In tracing the joint lines of migration and esthetic development noted in other paragraphs Dr. Fewkes became impressed with the fact that among the ancestors of the Hopi Indians the esthetic standards were much more permanent than the industrial standards. Throughout the entire course retraced by his researches—a course covering several distinct treks, alternating with periods of stable settlement, the whole covering some centuries—the symbolic devices inscribed on the fictile ware remained constant or underwent only slight and easily traceable modifications, while at each successive settlement new materials were utilized in the pottery making, the manufacturing processes and the final forms of the ware being manifestly adjusted to the character of the material. The discovery that the industrial activities (which directly measure the conjustment of man and environment) are the most progressive of the entire series is not, of course, novel; still less is it novel to learn that the especially conservative esthetic concepts, which are at once hereditary and prophetic, as shown by Groos, outlive whole generations of contemporaneous industrial concepts; yet the example is notably apposite and instructive, largely by reason of the freedom of the folk from external interference, with the consequent simplicity and integrity of the record. The details are incorporated in Dr. Fewkes's report on operations of 1896-97.

In the course of his reconnoissance of central and southern Arizona Dr. Frank Russell gave especial attention to the architectural features of the ruins, and defined a number of types, of which one or two are new to southwestern archaeology. The work was still in progress at the close of the fiscal year.

#### WORK IN SOCIOLOGY.

A portion of the year was employed by the Director in reviewing the abundant data in the Bureau archives relating to aboriginal institutions, and in systemizing the principles of sociology in the light of these data. One of the lines of inquiry, rendered important not only by inherent interest but by current problems growing out of the recent expansion of the territory of the United States, relates to slavery among the primitive peoples, and the researches render it clear that the relationships so designated vary widely with intellectual plane or culture grade—indeed, the social subordination of lower culture is so unlike the slavery of civilization that the application of the same designation to both institutions is quite misleading. In the slavery of civilization the slaves are not only aliens but chattels, whose personal ownership is definitely established and maintained through laws relating to tenure, bequest, conveyance, etc., but in savage society, in which personal proprietary rights are inchoate or non-existent, in which the tenure inheres practically or absolutely in the group, in which bequest is hardly, if at all, recognized, and in which thrift sense is lacking and property sense involved with mythic factors, such slavery is simply impossible. True, there are many recorded instances of slavery among lower tribes, but most of these rest on casual or superficial observation, or on other testimony stopping short of inquiry into the precise nature of the relations between the supposed slaveholders and the supposed slaves, while the convenience of the common term for the expression of social inequality has contributed to mislead recorders and (still more seriously) readers. To understand the so-called slavery of savagery it is necessary to grasp the mode of social organization characteristic of that culture grade. As shown chiefly through the researches among the American aborigines, such organization is based primarily on consanguinity (actual or imputed), and secondarily on age; and the relations growing out of these factors are kept constantly in the mind of every member of each clan and tribe by habitual forms of address. So the constituent individuals of a given clan are fathers and mothers, sons and daughters, brothers and sisters, and these relationships are constantly indicated in salutations, and even in ordinary conversation (the precise relationship to the speaker being commonly expressed also by a pronominal element). At the same time it is constantly borne in mind that father and son, mother and daughter, are not coordinate, the former being the superior by reason of greater age; similarly brethren are classed as elder brothers and younger brothers, while the female kindred of the same generation are classed as elder sisters and younger sisters, and the elder are always deemed superior, the younger inferior, in rank. By simple and practical extension of the system, the relative ages of all persons in the clan are kept in mind; and since, according to the universal usage of



savagery (so far as known), superior age confers authority, there is a practically simple, though theoretically complex, regimentation running through the entire clan, whereby the eldest person commands all and obeys none, while the youngest person obeys all and commands none, and each other person is entitled to command and bound to obey in the direct proportion of relative age. This regimentation is complicated by various factors, such as adoption, and (especially) what may be called promotion and demotion, i. e., advancement in "age" (rank) by common consent in recognition of prowess, etc., with correlative reduction in "age" as the penalty for cowardice, etc., so that the actual age relations may be completely lost; yet the imputed relationship serves practical purposes, and the organization is maintained with unimpaired efficiency by means of relationship terms. The same system is extended from the clan to the tribe, in which the several clans are ranked in the order of "age" (of course imputed), and eventually to the tribes united in confederacies; so that at last the system reaches every member of the tribal confederacy and each is entitled to command or bound to obey any other according to the relationship expressed in the form of salutation and constantly kept alive in conversation. True, uncertainties and differences of opinion may arise, especially between the remoter individuals and groups; commonly these are settled by more or less prolonged deliberation and discussion, or "council," though some of the bloodiest wars of Indian history grew out of such misunderstandings; yet even the appeal to force and arms but serves as a means of settlement of the dispute, for the conquerors thereby become the elder and the conquered the younger in primitive thought. So, too, when stranger tribes meet, both are constrained by universal tribal law, and proceed to council or war, as the case may be, for the purpose of fixing the relative "age," with the consequent right of command, and in some cases the question may remain open for centuries (as between the Apache and the Papago) and lead to interminable warfare. Now, the conquered tribe may merely retire from the field of dispute, leaving what both conceive to be the verdict of superhuman potencies beyond reach of continuous execution; but if the contestants are actually related, or if the conquest is complete, they commonly remain in association, the survivors of the conquered families being absorbed or more formally adopted into the conquering tribe, and perhaps distributed among the families of that tribe, whereupon all the captives become subordinate to each and all of the conquerors, to whom thenceforth they owe obedience. Commonly it is this condition of obedience on the part of a certain class or group to the commands of another class or group which impresses observers and leads to the records of slavery among primitive folk, though the institution involves no ownership of human chattels, no rights or duties save those connected with a system of rank correlated with relative age, actual or imputed. The institution might better be styled wholesale adoption, or collective adoption, than slavery. Among the American aborigines the captives, or adoptees, are usually assigned an "age" corresponding with the time of their entry into the tribe, so that they are compelled thereafter to obey all children then living, and are entitled to command all children subsequently born into the tribe, and there is thus a

fixed way whereby they attain in time the rank of the conquerors. Moreover, the method of promotion permits any "slave" (i. e., captive-junior) to attain "age" by the display of prowess, industry, skill, generosity, or other attributes appealing to the sentiments of primitive men. Among certain other peoples, the custom of collective adoption appears to be so modified that the captives remain juniors not only to members of the captor tribe born anterior to the captivity, but to all others, and it is this modified institution which matures in actual slavery with the development of property-sense; but even in this case there are (at least in the early stages) devices for the manumission or liberation of, or the acquisition of rank by, captives (or captive-descendants) of exceptional abilities. The several primitive customs grade into the institution of slavery proper in ways which are of much interest, but which need not now be followed; it suffices to emphasize the important distinction between the captive subordination of primitive peoples and the real slavery of some civilized nations.

In the course of his researches among the Cocopa Indians Mr. McGee discovered several industrial factors of dispersive tendency, i. e., factors tending to weaken home ties and family bonds and to scatter the families and clans; and naturally these factors are reflected in the social organization. The tribe is now distributed over an area of several thousand square miles, extending from the international boundary on the north to the head of salt water (of Gulf of California) on the south, and from the eastern border of the Colorado bottom to the base of Cocopa Mountains; and within this area are seven subtribes, of which some, and perhaps all, are really clans, each organized under a subchief and all definitely united under a head chief, the present incumbent of this office being a man of parts, an orator of ability, and a leader of much shrewdness, commonly known as Pablo Colorado. Now, naturally (and necessarily for the maintenance of tribal integrity) the dispersive factors are counteracted and balanced by connective factors; and while it is probable that some of these remain undiscovered, a few others of no small significance were detected by Mr. McGee. As already mentioned, the mortuary observances include sacrifice of all the immediate belongings of decedents, for immediately after the death of a tribesman his personal possessions—horse, saddle, weapons, implements, apparel, grain and other food stuffs, bedding, dogs, etc.—become public and are distributed among nonrelatives in the order of arrival, while any unclaimed residue is burned with the body and house. Several social consequences attend this industrially improvident procedure. In the first place, the largess is an incentive to maintaining connection between the scattered families and clans and to lively (albeit morbid) interest in the state of health of invalids, thrifty producers, and other members of the tribe; again, the actual mortuary distribution brings together scattered tribesmen and their families and unites their interests in ceremonies of affecting if not imposing character; and finally the material sacrifice commonly leaves dependents (widows, children, and perhaps agelings) to be supported by the informal public bounty of tribal life, or perhaps to be distributed among scattered families in such manner as to strengthen sentiments of communality and to keep alive the sense of community in interests. This factor is prominent in the customs of the tribe.

and its influence is direct and easily traceable. A less direct factor of similar tendency is found in the marital custom, or rather in the observances preceding and preparing the way for marriage. The girls' puberty feast is, indeed, one of the most imposing and widely heralded of the tribal ceremonies; commonly it brings together representatives of all the subtribes or clans; and the proceedings are conducted with extreme formality and dramatic impressiveness. The principal ceremony lasts through a night, following a day of preparation and followed by another day of final feasting, accompanied by games, etc. The central episode is the temporary burial of the novice; a shallow pit is excavated, and in this a fire is made, as for a fish bake; after the earth is thoroughly warmed the remaining fuel and coals are removed, the girl is placed in the pit and buried to the neck with the earth thrown out in making the excavation; there she spends the night, and in the morning is extricated and brought before the assembled tribesmen as a woman; and commonly a match is made with a representative of some more or less remote branch of the tribe. Through the ceremony community of thought is maintained in most effective fashion, and through the resulting union family sentiments are united to the extent that a common consequence of marriage is the breaking of a new path, often many miles in length, through the luxurious herbage of the annually flooded bottom land. The formal organization of the Cocopa tribe is in large measure esoteric, so that it can be ascertained fully only after prolonged and intimate acquaintance with the tribesmen, but the preliminary investigation serves to show that the field of inquiry is one of promise.

In his comparative study of myths, Mr. J. N. B. Hewitt has found various references to social customs of such sort as to indicate clearly certain archaic institutions of the Iroquoian Indians. Thus the Onondaga legends illumine the legislative and executive customs of the tribe, and, while ostensibly giving traditional warrant for the customs, they really picture a somewhat earlier stage in the development of institutions than that found by the Caucasian pioneers. In this tribe all matters of public policy, especially the selection of chiefs and the discontinuance of war, were first considered by the elder women in fairly definite clan councils. Their conclusions were formally communicated to a male spokesman, usually the elder brother (actual or putative) of the elder woman, and by this spokesman, with others of similar character from the other clans, the opinions of the mothers were brought before the exclusively masculine tribal council for debate and final decision. In this way the women sitting in clan council constituted the primary legislative body, while their brothers sitting in tribal council formed a senate or final legislative body whose decisions were binding on the executives of clans and tribes; so that the social organization may be classed as adelphiarchal (like that of the Seri Indians described in earlier reports) in principle, though largely patriarchal in detail. As among the Seri, too, the maternal features of the legislation were paralleled by recognition of large maternal rights in material possessions—e. g., throughout the Iroquoian tribes the control or nominal ownership of lands was in the women as the collective and perpetual mothers of the tribe. These and other points of general interest are set forth fully in Mr. Hewitt's memoir, which has been assigned to the Twenty-first Annual Report.

## WORK IN PHILOLOGY.

Throughout a considerable part of the year the Director was occupied in developing and applying the system of linguistic classification foreshadowed in the last report. Primarily, languages are devices for the expression of thought; secondarily, they are mechanisms for shaping thought. The simplest languages are emotional and largely demonstrative, comprising not only articulate vocal utterances, but inarticulate sounds, gestures, facial expressions, etc., and these spontaneous expressions of feeling and thought grow into the four leading lines of linguistic development. The simplest of these is gesture language (or sign language), which arises largely in pantomime, but matures under favorable conditions in highly complex systems such as those investigated by the late Colonel Mallery and more recently by Maj. H. L. Scott (whose studies were unfortunately interrupted by the Spanish-American war). A far more important line of linguistic development is that of oral speech, and the activities of expression have been so long and so vigorously exercised in this line as to have developed a series of special organs differing widely in refinement of function and delicacy of structure from those of lower animals. By means of these organs the speaking animal, Man, makes mastery of sound, which is created at will and reduced to vocables, notes, sentences, in such manner as to convey ideas of the utmost complexity with hardly perceptible loss of meaning; and with the development of words and sentences lexicology and grammar arise, while etymology and sematology gradually acquire importance. The third line of linguistic development is that of written language, which first involved manual adaptation, together with a revolution in mode of thought, and afterward involved the invention of that long series of mechanical devices now forming the sign and measure of higher intellectuality. The last line of linguistic development is that represented by characters expressing quantitative values; it may be styled logistic language. Although based primarily on the rich records of aboriginal American languages preserved in the archives of the Bureau, the system of linguistic classification has been shaped by extended comparisons with the various languages of Europe and Asia, together with some of those of Australia, Africa, and Polynesia. The system has been freely discussed with students and has been published in preliminary form for the purpose of eliciting further suggestion and criticism; it is expected that the matter will be incorporated in full in an early report.

In connection with the linguistic classification, the Director has continued to study the recorded languages of the Mexican and Central American tribes, with a view to the classification of these tribes by linguistic affinities in a manner corresponding to that already adopted for the American tribes north of Mexico (and published in the Seventh Annual Report). In this work he had the constant assistance of Dr. Cyrus Thomas, whose familiarity with the literature of the southern districts of North America proved invaluable. Before the end of the year a preliminary classification was made and mapped; but it is deemed unwise to submit the matter for publication pending reexamination of various critical points. It has been the good fortune of the Bureau to see the classification and mapping

of the tribes north of Mexico adopted widely, and it is naturally desired that the continuation of the work southward shall be equally worthy of acceptance.

Dr. Albert S. Gatschet continued the arrangement of the comparative Algonquian vocabulary, and also carried forward his analysis of the complex structure of the Peoria language. In both directions his progress was considerable and his results of much value, not only as an aid in formulating the linguistic classification above described, but to the collaborators of the Bureau and students generally.

Dr. Franz Boas continued the arrangement of linguistic material for publication at intervals throughout the year. In addition, he revised the proofs of his memoir entitled "Kathlamet Texts," submitted just before the close of the last fiscal year and transmitted for publication in bulletin form early in the present year. By reason of the highly technical character of the matter, composition was necessarily slow and proof reading laborious; but the matter is now all in type.

The Natick Dictionary, compiled from the Eliot Indian Bible by the late James Hammond Trumbull (noted in the last report), is still in the printer's hands, though nearly ready for publication.

In connection with the collection of Iroquoian myths, Mr. Hewitt has continued recording the vocables and working out the grammatic structure of the languages spoken by several Iroquoian tribes. Some of the results of the work will appear in his memoir on comparative mythology now practically ready for the press; others are in condition for incorporation in future reports.

As already noted, Mr. John R. Swanton spent the entire year in collecting linguistic material in British Columbia. The languages of this district give promise of special importance in their bearing on questions of tribal migrations and intertribal relations. Mr. Swanton has not yet taken up the preparation of his material for publication.

The work on the *Diccionario de Motul*, described in the last report, is still under way. A considerable portion of the manuscript in Maya and Spanish was transcribed by Miss Jessie E. Thomas during the year, and Señor Andonaro Molina, of Merida, Yucatan, is engaged in furnishing an English translation and in extending the vocabulary through personal acquaintance with the Maya tongue.

#### WORK IN SOPHIOLOGY.

As indicated by the contents of previous reports, the Director has for some years been engaged in developing a system of anthropologic classification designed primarily to serve as a basis for the researches in the Bureau, though it is hoped that the system will be of use to the students of the Science of Man throughout the world. It was through the partial development of this system that recognition was led first to discrimination of the human activities and later to the definition of the five groups of activities observed in the researches and described in recent reports. During the last five years several of the groups or categories of activities have been formulated and characterized with some degree of fullness. The treatment began with the arts, or esthetic activities, and proceeded to the

industries, or technical activities, and thence to the institutions expressing social activities. During the past year the characterization was extended to languages, or the activities designed for expression, as already set forth, and toward the end of the year the last and most complex of the activital groups, i. e., the sophic activities involved in opinion, together with myth, faith, and the more refined and ennobling products of mentation, was taken up. Fair progress was made in the analytical work, and it is anticipated that definite results will be reported at an early day.

During his Southwestern expedition Mr. McGee found opportunity to witness certain ceremonies of the Yaki Indians, which were of interest partly because the tribe has been little studied, partly by reason of the prominence of zoic motives in the vocalization and instrumentation, as well as in the gestures and movements of the ceremonial dance. In portions of the ceremony each actor impersonated an animal. He wore a head-dress (not extended into a mask, as among more northerly tribes) consisting of a scalp, with ears, horns, and other appendages of the animal kind, and leggings abundantly decorated with claws or hoofs of the same animal. He carried a rattle or flute, used to imitate the voice of the tutelary or the sound of its movements, while he imitated its notes of alarm, fright, pain, and pleasure with his own voice, and mimicked its corresponding movements; yet in other parts of the ceremony the same actors passed by carefully graded stages into the strictly conventional movements of a dance involving collective action of considerable complexity. Briefly, the ceremony seemed to be characterized by a remarkable combination of symbolic and conventional features, indicating an exceptional range from the primitive impersonation to the formal figures and movements attending moderately advanced culture.

Mr. James Mooney continued his researches relating to the mythology of the Cherokee Indians, making good progress in the collection of additional material in the field, as well as in the extension of comparisons between the myths of the Cherokee and those of other tribes and peoples. The application of comparative study to primitive mythology is proving highly instructive and useful. In the infancy of ethnologic research students were frequently struck by the discovery of activital parallels, or similarities, among more or less remote peoples, and were led thereby to infer previous contact, or even closer relationship, between the peoples; but as study progressed and new parallels were discovered, even among the remotest peoples of the earth, the verity of the inference came to be questioned, and finally the law of activital coincidences was formulated as a convenient generalization of the facts connected with independent development of devices produced in the constant adjustment of the intelligent organism to its environment. At first the law of activital coincidences rested chiefly on industrial artifacts; then it was found to have equal support in the esthetic products of various peoples; next it was found to have still stronger and more direct support in institutions, i. e., in the devices and features of social organization; while certain features of language were found also to indicate the extent and efficiency of coincidental interaction between mind and nature in shaping the activital

products. Hitherto most investigators of mythology have been content with discrete studies and explorations, or, at most, with exoteric parallels. Accordingly many of them have stopped with the inference of former contact or kinship on which the students of industrial artifacts rested a quarter century ago, i. e., their studies were such as to bring out resemblances among the mythic systems examined, but not such as to detect and properly emphasize the essential differences. Now, Mr. Mooney's comparisons, although not exhaustive, are sufficiently general to permit discrimination of the exoteric coincidences from esoteric motives in the myths. Accordingly they clear the way for the application of the law of aetivital coincidences to primitive mythology, if not to sophiology in general. The greater part of the material completed for publication has been incorporated in the memoir on "Myths of the Cherokee," mentioned in the last report.

Another comparative study of myths has been carried forward by Mr. J. N. B. Hewitt; and this investigation is noteworthy in that the comparisons are confined to a limited group of confederated tribes (of the Iroquoian stock) and in that the features compared are in exceptional degree esoteric. The myths were obtained at first hand and carefully recorded and verified in the aboriginal terminology, after which literal and free translations were made, so that each chapter of the work is at once a linguistic record and the best obtainable version of the ancient traditions. Now, it is noteworthy that most of the similarities found thus among the several Iroquoian myths are rather external than internal, rather superficial than essential, and, concordantly, that the more important differences are primarily internal, i. e., more directly connected with concept and motive than with ritual and emblem. The voluminous material was practically ready for the press at the close of the fiscal year and has been assigned to the Twentieth Annual Report.

During the closing months of the year Dr. Fewkes was employed in summarizing his own observations and those of others in the Pueblo region, with the object of presenting an outline of Pueblo mythology. As noted in earlier reports, the Pueblo region is arid, and hence infertile and harsh as an environment for human inhabitants, and the harshness of environment is curiously reflected in highly differentiated beliefs and ceremonies, so that the Pueblo region as a whole may, perhaps, be regarded as a sophic province, i. e., a province defined by a distinctively typical series of myths and faiths. Good progress was made in the work, which was not, however, completed at the close of the fiscal year.

In addition to the inquiries connected with the classification of the languages of Mexico and Central America, Dr. Cyrus Thomas gave continued attention to the hieroglyphic records of the inscriptions and sculptures of Yucatan and interior Mexico, materially supplementing and extending his paper on calendric systems, now in type as a part of the Nineteenth Annual Report. He made some progress also in the preparation of a final memoir on the codices.

Although seriously handicapped by ill health, Mrs. Matilda Coxe Stevenson continued the preparation of her memoir on the ceremonies and

myths of the Zuñi Indians. A portion of the manuscript was submitted for editorial revision in May, and the remaining chapters were reported as nearing completion at the end of the fiscal year.

As noted in the last report, an exceedingly valuable acquisition was made through Miss Alice C. Fletcher in the form of the Pawnee ritual known as the Hako; but on arranging the material for printing certain breaks were found which seemed of such importance as to warrant postponement of publication pending further efforts in the field to complete the ritual. Accordingly Miss Fletcher revisited Oklahoma, and afterward brought her principal informant to Washington, where the record was finally completed. The ritual is remarkable for extent and completeness, for the clear light which it throws on archaic customs and beliefs, and for the systematic and harmonious development of the musical and terpsichorean features. The original record was obtained by aid of the graphophone, and this record was then written in words and musical notation, and afterward verified by repetition. On the whole the ritual is one of the most complete ever acquired by the Bureau, and is in every way worthy to be regarded as a type of aboriginal ritualistic production. The final arrangement of the material was nearly complete at the close of the fiscal year, when the work was interrupted by Miss Fletcher's temporary absence from the city.

#### DESCRIPTIVE ETHNOLOGY.

During the earlier portion of the year Mr. F. W. Hodge continued the preparation of the Cyclopedia of Native Tribes in connection with editorial work, his progress in both lines being highly satisfactory. On January 31 he resigned his connection with the Bureau to accept a position in the office of the Secretary. The Cyclopedia material was then turned over to Mr. Mooney, who has made some progress in preparing it for publication.

During the earlier months of the year Col. F. F. Hilder was, by temporary transfer, engaged in making collections in the Philippine Islands under the auspices of the Government Board of the Pan-American Exposition. After his return he resumed his duties as ethnologic translator and continued the transcription, translation, and annotation of an early Jesuit manuscript history of Texas, obtained through the instrumentality of the Bureau, but now preserved in the Library of Congress. The sketch was found rich in important ethnologic data, and the anonymous author was identified by Colonel Hilder, through collateral information, as Padre Morfi. The work was nearly completed when brought to a premature end by the sudden death of Colonel Hilder on January 21.

#### COLLECTIONS.

As usual, the several collaborators engaged in field operations made more or less extensive collections for purposes of study and for ultimate transfer to the U. S. National Museum. The largest collection of the sort was made by Mr. McGee among the Cocopa Indians. It comprised domestic utensils of wood, stone, and clay; several bows with arrows; war weapons; complete suits of women's apparel; cradles; decorative and symbolic



objects of shell and bone; flutes, rattles, etc., together with the chief vegetal food products used by the tribe, the collection being sufficiently complete to permit the construction of one or more life-size groups. The most elaborate war weapon is of interest in that it is designed to serve at once as standard and spear and in that the sharpened point for the latter use is at the inner end of the shaft, so that the weapon illustrates the centripetal movement of lowest culture rather than the centrifugal arm movement characteristic of advanced culture. Smaller collections were made by Mr. Mooney among the Cherokee Indians, by Mr. Hewitt among the Iroquoian Indians of Canada, and by Dr. Russell in Arizona. A number of collections were obtained also by purchase under the more immediate direction of the Secretary. Among these may be mentioned the Steiner collection of stone implements from Georgia, which comprises a large number of types and of which a portion was obtained during the last fiscal year. Another collection of special note was obtained from Maj. H. N. Rust, of Pasadena, Cal. It comprises several types and numerous examples representing the stone artifacts of southern California. Advantage was taken also of the opportunity to acquire a number of the remarkably faithful Indian portraits executed by Mr. J. H. Sharp, of Cincinnati. A particularly instructive collection of obsidian blades (including the largest known specimen) was also obtained during the year through Mr. Nathan Joseph, of San Francisco, while a few particularly fine pieces of aboriginal Alaskan workmanship were obtained from Lieut. G. T. Emmons. A small collection of basketry produced by the renegade Apache at Palomas was picked up by Mr. McGee, together with several pieces of Pima basketry made near Maricopa. A small but noteworthy object obtained was an authenticated Sitting Bull belt of beaded elk skin; and half a dozen small collections of stone implements and weapons were secured.

#### PROPERTY.

The property of the Bureau is practically limited to (1) office furniture and apparatus, (2) ethnologic manuscripts and other original records, (3) photographs and drawings of Indian subjects, (4) a working library, (5) collections held temporarily by collaborators for use in research, and (6) undistributed residue of the editions of the Bureau publications. The fiscal year witnessed little change in the amount or value of the office property. The accumulation of manuscripts and other records of original work progressed steadily; about a thousand photographic negatives, together with several hundred prints and a number of drawings, were added to the collection of illustrative material. The library maintained normal growth chiefly through exchange, and the number of back reports was considerably reduced through the constantly increasing public demand for ethnologic literature. Mr. J. Julius Lund continued in charge of the property as custodian.

#### PUBLICATION.

Mr. F. W. Hodge continued in charge of the editorial work until his resignation took effect, as already noted, after which this work was conducted by Mr. H. S. Wood. The first part of the seventeenth report and

the first part of the eighteenth report were received from the Government Printing Office during the year, and these, with the second part of the seventeenth report, have been distributed. The second part of the eighteenth report was not delivered up to the end of June, while neither of the two bulletins of the new series was quite complete; and the nineteenth report, though nearly all in type, was not yet ready for the bindery at the close of the year.

Mr. De Lancey Gill remained in charge of the illustrative work, preparing copy for and revising proofs of the numerous illustrations for the eighteenth and nineteenth reports. He also made photo-portraits of some two hundred Indians, chiefly members of delegations visiting Washington in the interest of their tribes, and developed a considerable number of negatives made by the several collaborators in the field.

#### NECROLOGY.

On January 21, 1901, the Bureau suffered a grievous loss in the death of Col. F. F. Hilder, ethnologic translator. Colonel Hilder was a student of ability and remarkably broad experience, and although his formal connection with the Bureau began only on July 1, 1898, he had made himself a place among the most valued and trusted members of the corps. A more extended account of his career will be transmitted later.

I have the honor to be, yours, with respect,

W J MCGEE,  
*Acting Director*

Mr. S. P. LANGLEY,  
*Secretary, Smithsonian Institution.*

### APPENDIX III.

#### REPORT ON THE OPERATIONS OF THE INTERNATIONAL EXCHANGE SERVICE FOR THE YEAR ENDING JUNE 30, 1901.

SIR: I have the honor to submit the following report upon the operations of the International Exchange Service for the year ending June 30, 1901:

The equipment of the five rooms in the south basement of the Smithsonian building, which have been used exclusively by the International Exchange Service during the last eight years, consists of such furniture and appliances as are necessary to the work, chiefly among which are tiers of upright bins opening in front and occupying nearly all the wall space of two rooms, into which packages of publications for distribution abroad are temporarily placed until a sufficient quantity has accumulated to constitute a shipment to the respective distributing bureau of each country.

Much space is required for geographically arranging and for recording parcels, for which purpose several large counters are arranged in the center of each of three of the rooms which are devoted to this part of the work.

There are also cases containing indexes and acknowledgments and a card record of all packages sent to and received from each correspondent, correspondence files, library shelves for current directories of the principal cities of the world, desks, copying presses, typewriting machines, etc.

The property acquired during the year consisted principally of boxes, packing materials, stationery, and other necessary supplies, costing in the aggregate \$2,339.53.

The rooms assigned to the Exchange Service have for a long time been inadequate to the increasing demands, but no additional space was available until the recent changes in the heating plant of the Institution made it possible to add 360 square feet to the shipping department. This alteration made it necessary to change the brick walls, construct an area window, lay new flooring, and build additional bins. These expenses and those incurred on account of laying new floors in the entire suite of exchange offices during the early part of the present fiscal year were borne by the Smithsonian Institution, and no part of them were paid from the Congressional appropriation for support of the International Exchanges.

Considering the fact that almost every fast steamer leaving New York for foreign ports takes a consignment of international exchanges from the Smithsonian Institution, it is not surprising that there should be some losses every year. During the last twelve months, however, there has been but one instance of either loss or damage, and the year's record is therefore one of the best in this regard.

The event above mentioned occurred in February last, when two cases of exchanges destined for correspondents in New South Wales were damaged by fire and water in the hold of the steamship *Castano* while loading at her pier in Brooklyn, N. Y. The cargo was subsequently discharged and the two cases returned to the Institution, but upon examination their contents were found to be unfit for use, and the United States Government publications were sent to the Superintendent of Documents to be rebound, and duplicates were substituted. The contributors of the miscellaneous scientific publications were each notified of the facts, as is customary in such instances, and were asked to supply duplicates. In almost every instance they complied.

The operations of the Exchange Service during the year are graphically shown in the accompanying statistical tables. They show a marked increase over the transmissions of the preceding year.

The number of correspondents in the United States has been increased during the year by 428 and those in other countries by 1,326. The total number of correspondents in the United States is now 8,149 and in all the rest of the world 27,556, or a grand total of 35,705, the number of countries participating being 148.

During the year 121,060 packages of publications, weighing 414,277 pounds, were received for transmission, being an increase over the previous year of 7,497 parcels and 4,286 pounds in weight.

The sum of \$24,000 was appropriated by Congress for the support of the International Exchanges, being the same as appropriated for the preceding year. A special effort is continually being made to improve the transportation facilities, and fast mail steamers are selected to carry exchanges to all parts of the world when practicable. An unavoidable delay is always encountered when discharging the cargoes of vessels, and freight is often detained for several days at the ports of debarkation, owing to the confusion and inadequate terminal facilities. This difficulty has been overcome to some extent by forwarding small consignments of exchanges by express instead of by freight, thus receiving more prompt attention.

Mr. John C. Williams, deputy collector of the port of New York, was designated on January 30, 1900, to represent the Institution in the matter of clearing exchanges received from abroad, vice Mr. John Quackenbush, deputy collector, who asked to be relieved on account of advancing years and increased official duties. The efficiency and prompt-

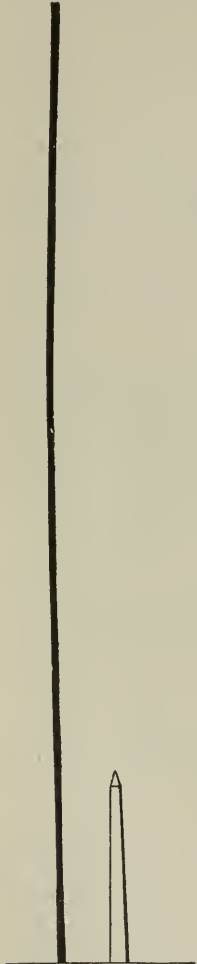

Diagram illustrating height of packing boxes, resting one upon another, used in transmitting exchanges from the United States to foreign countries during the fiscal year ending June 30, 1901, as compared with the height of the Washington Monument. Height of monument, 555 feet; height of boxes, 2,775 feet.

ness with which Mr. Williams has since performed these duties are highly satisfactory, and his valuable services are much appreciated by the Exchange Service and its correspondents.

Although the universal system of exchanges is now supported in many countries by official recognition and Government aid, there are some which have not yet established official bureaus for the purpose, among the most important of which are Great Britain, Germany, and Austria-Hungary. The free interchange of publications between the United States and each of these countries is considered so important that the Institution has for many years provided for the entire expense of conducting exchange relations with each, even to employing salaried agents for the purpose. Messrs. William Wesley & Son, in London, Dr. Felix Flügel, in Leipsic, and Dr. Joseph von Körösy, in Budapest, Hungary, represent the Institution in the matter of exchanges between this and their respective countries. While the entire burden of expense for this service has been upon the Institution for nearly fifty years, the good to the scientific world would perhaps seem an ample reward, but it is feared that the time is not far distant when an equitable division of the expenses must of necessity be insisted upon.

The services of many professional men and of many educational institutions throughout the world which have been cheerfully and gratuitously given in aid of the service are much appreciated, and while it is not possible to mention each name in this limited space, it is hoped that they will consider this expression of appreciation as particularly applicable to them.

The war in South Africa has necessitated the discontinuance of sending to Pretoria the official publications of this Government, but the recent issues are held in reserve by the Institution until such time as they may be safely forwarded.

Arrangements for distributing contributions for miscellaneous correspondents in Japan are still incomplete, and, acting under instructions received through the Japanese minister to this capital in October, 1896, only such exchanges as are destined for governmental institutions and individuals officially connected therewith are accepted for transmission.

As yet no action has been taken in China, as far as known to the Smithsonian Institution, with a view to establishing an exchange bureau, and at present only such parcels as are addressed to the imperial customs service and to correspondents in Shanghai are accepted. These are again, after a temporary interruption, distributed by the Zi-Ka-Wei Observatory at Shanghai.

Since the Biblioteca Nacional at Quito, Ecuador, consented to act in the capacity of exchange distributing agent in January, 1900, eight cases of exchanges have been sent by the Institution to the port of Guayaquil, but no exchanges have as yet been received from Ecuador except by post. This absence of reciprocal benefit is perhaps due to the difficulty of transportation between Guayaquil and Quito, which it is hoped will be overcome in due time.

While in Europe unofficially during the month of July, 1900, Mr. F. V. Berry was instructed to investigate the transportation of exchanges to the United States, and the terminal facilities in London, with a view to both the expediting of consignments and, if possible, the reduction of expenses.

Mr. Berry's report showed conclusively that the methods employed in transporting exchanges between London and New York could not be improved upon, and that any attempt to hasten the distribution of parcels throughout Great Britain would greatly increase the expense beyond the limit that the institution was able to allot to this branch of the service.

Mr. W. Irving Adams, chief clerk of the International Exchange Service, was instructed by the Secretary to visit Italy, Switzerland, Austria-Hungary, and such other countries in Europe as he might deem expedient, with a view to the general improvement of the service at large, and through personal contact to establish more intimate relations, if such were possible, with the several exchange bureaus and agencies in those countries. Mr. Adams sailed from New York on May 15, with the expectation of being absent about three months. His report, although covering a part of the next fiscal year, is here given:

OCTOBER 9, 1901.

"SIR: In accordance with your instructions to proceed to Austria-Hungary, Italy, Switzerland, and such other countries as, in my judgment, might be advisable, for the purpose of promoting the interests of the international exchange service, I sailed from New York on the 15th of May last, debarked at Antwerp, Belgium, May 26, and at once proceeded to Vienna, Austria.

"*Austria-Hungary.*—The K. K. Statistische Central Commission, Schwarzenberggasse 5, Vienna, was designated as the exchange agency for Austria, at the instance of Dr. Edward Suess, president of the Imperial Academy of Sciences, and as a result of my visit to Vienna in 1897. Previous to that time all contributions from this country for Austria-Hungary were distributed through the agency of the institution in Leipzig, Germany, and the importance of establishing independent agencies in Vienna and Budapest was made doubly apparent, inasmuch as the agency at Leipzig was becoming overburdened with work, and, furthermore, the returns were not as large as it was thought they would be if separate agencies were established. This theory has been substantiated by facts, and the contributions from Austria-Hungary have gradually increased from year to year.

"Prof. Karl Theodore von Inama-Sternegg, the president of the K. K. Statistische Central Commission, is much interested in the exchange service and is disposed to render every assistance possible. He cheerfully assented to all the changes which I proposed to him and even volunteered to make a personal effort to procure the official publications of his Government and the municipal publications of the city of Vienna for the Library of Congress and to send them as early as practicable.

"The freight charges for transporting exchanges from Vienna to Hamburg, and vice versa, have seemed to be excessive, and it was my purpose to ascertain if consignments could not be made by rail to Trieste or Fiume and thence by steamships to New York, which regularly touch at Adriatic and Mediterranean ports. I found upon inquiry that while the latter course might save the Institution perhaps \$50 to \$75 per annum, the time consumed in transit, owing to the fact that the steamers in the Adriatic service are exceedingly slow, would be nearly three times as great, and

that the efficiency of the service with Austria-Hungary would thus be seriously impaired. I learned, further, that merchants usually shipped their goods to the United States from European Atlantic ports whenever time was an object to be considered.

"Under the circumstances noted above, I beg to recommend the continuance of the practice of sending exchanges to Vienna and Budapest via Hamburg for the present, at least, or until such time as an official exchange bureau supported by the Imperial Government of Austria-Hungary shall be provided for.

"Dr. Joseph von Kőrösy, director of the statistical bureau of the city of Budapest, was appointed agent for the Institution for the distribution and forwarding of exchanges at the conclusion of my visit to Hungary in 1897, and has since served in that capacity. Prior to my arrival at Budapest Dr. Kőrösy had been ill for several weeks, but was then convalescent and had resumed his official duties.

"Dr. Julius Pikler, his assistant, personally attends to the distribution of exchanges, and keeps a record of all parcels received and forwarded. For this service Dr. Pikler receives each year from the Smithsonian Institution 300 kronen—equivalent to \$60. On account of his faithful and efficient performance of duty, I beg to recommend that his compensation be increased to 500 kronen, or \$100 per annum.

"The bureau of statistics has for many years been located in a large building known as the "Redoute," but during the month of September was to have been moved to the city hall, where the library of the bureau, numbering 27,000 volumes, and the official library of the city will be consolidated and placed under Dr. Kőrösy's charge.

"In response to my request, Dr. Kőrösy promised to procure, if possible, copies of all the publications of the city of Budapest for the Library of Congress, though he feared that they could not be obtained for several months, but would be eventually. He fully realizes the importance of exchanging publications with foreign countries, especially with the United States, but regrets that other officers of the city government do not place the same value upon a mutual exchange, and for that reason little provision is made for surplus copies.

"While in Budapest I made the same inquiries with regard to reducing the expenditures for transportation of exchanges that I did in Vienna, but met with a similar expression of opinion, which led me to favor a continuance of the present custom of using the route to and from Hamburg on account of better service, though the freight rates are considerably higher than by Adriatic ports.<sup>1</sup>

---

<sup>1</sup>Since my return to Washington I learned that Dr. Kőrösy addressed a letter to the Secretary bearing the date of July 11, in which he refers to my visit and to the matter of inland freight on exchanges. He proposes to ask the State railways of Hungary to transport exchanges between Budapest and Fiume without charge, and will also attempt to obtain a concession from the ministry of posts and telegraphs to enable exchange parcels to be forwarded free of postage. Concerning this concession, however, he has little hopes for success.

“From Budapest it was my purpose to next go to Venice, but as the most direct route took me through Vienna I availed myself of the opportunity of personally conveying my compliments to Dr. Suess, a foreign associate of the National Academy of Sciences of the United States and the president of the Imperial Academy of Sciences of Austria. The International Exchanges owes much to the efforts of Dr. Suess in promoting its interests in Austria, as he was instrumental in arranging for the agency in Vienna as now constituted, and his personal acquaintance with many eminent scientists in the United States and his visits to this country from time to time have served to make him an interested student of America's progress in science.

“*Italy.*—Although my principal official duties in Italy were confined to the Biblioteca Nazionale Vittorio Emanuele in Rome, I was favored with the promise of complete sets, so far as they were available, of the municipal publications of the cities of Venice, Bologna, Florence, Rome, Naples, Genoa, Turin, and Milan. The sincerity of these promises is proven by the fact that large consignments from Florence, Rome, and Genoa have already been received and deposited in the Library of Congress, while advices are at hand that other collections are on the way.

“In exchange for these valuable contributions it is understood that the Library of Congress will send to the libraries of the cities above mentioned such publications of this Government as from their nature will be of interest to municipal governments generally, and, among others, to include the reports upon Commercial Relations, Commerce and Navigation, District of Columbia, and the Department of Labor, the Statistics of Railways, Consular Reports, and Statistical Abstracts.

“Count Domenico Gnoli, director of the Biblioteca Nazionale Vittorio Emanuele at Rome, assured me that all the official publications of the Kingdom of Italy which were available and not possessed by the Library of Congress would be supplied, and, in my presence, he gave instructions to that effect.

“The International Exchange Service of Italy—Ufficio degli Scambi Internazionali—is located on the second floor of the National Library Building, and is approached by a stairway on the left of the main entrance and independent of the grand staircase leading to the Library. The space occupied as the office for the exchange service consists of one long room well lighted and well adapted to the purpose.

“The relationship of the Italian Exchange Service to the Biblioteca Nazionale Vittorio Emanuele is similar in some respects to that of the international exchanges to the Smithsonian Institution.

“Signor Cavaliere Giovanni Garavini, the chief of the bureau, showed me many courtesies and gave me every possible opportunity to familiarize myself with his methods, which, though systematic and complete, do not, on account of the limited requirements, demand the same detail necessary to ready reference as is practiced by the Institution.

“The sum of 5,000 lire is annually provided by the National Library for conducting exchanges, and the charges on contributions by Italian correspondents for foreign distribution are prepaid by the bureau to ports of



debarkation in other countries in accordance with the conditions of the Brussels treaty concluded in 1886. The distribution of exchanges in Italy is not made with the same dispatch that is considered by the Institution as of the utmost importance in forwarding parcels to addresses in this country after their arrival from abroad. Instead of being allowed the right to frank exchanges through the mails, a privilege enjoyed by the Institution, all parcels received for each city in Italy are forwarded to a single address in that city by freight and are then distributed by local means. This custom, which was doubtless instituted in the interest of economy, it seems impossible to improve upon until the allowance for the transportation of exchanges shall be substantially increased, which, however, can not be expected in the immediate future.

"The proffer of Signor Garavini of his hearty cooperation with the Institution at all times, to the end that a mutual exchange of publications, both governmental and scientific, may be made more general and effective between Italy and the United States, coupled with the many favors bestowed upon me unsolicited, and the assurance that he would hold himself in readiness at all times to serve the Institution in any capacity, were reassuring of the esteem in which the Institution is held in the Kingdom.

"*Switzerland.*—After concluding my work in Italy I proceeded to Switzerland and visited the cities of Zurich and Bern, in both of which I received assurances that all their municipal publications would be sent to Washington, through the Swiss exchange service, as early as practicable.

"Mr. H. Angst, the British consul-general for Switzerland, is the director of the Swiss National Museum, which is located in Zurich. Mr. Angst was especially obliging and offered me every facility for examining many parts of the building to which the public is not admitted, including the shops of the workmen and preparators.

"This museum is new, complete in every detail, and occupies a most desirable position in the center of the city, facing a beautiful park. The architecture of this building is unique, especially with regard to the arrangement and finish of the rooms devoted to Swiss history, which are made to conform to the age contemporary with the articles of furniture, implements, customs, and arts, which are appropriately installed in them. In order to make the construction of these rooms conform to the many interesting epochs in Swiss history it was necessary to dismantle many monasteries, churches, and chateaux, but this has been done with a minimum of expense and with a view to perpetuating the beauties of historical architecture, instead of losing all semblance of ancient customs with the decay and abandonment of old buildings which have been discarded for more modern structures.

"The Swiss international exchange service, conducted by Dr. Gurtner, is a division of the bibliothèque fédérale centrale, Bern. For many years it has been the custom of Dr. Gurtner to send Swiss exchanges for correspondents in this country to Dr. Flügel, the agent of the Institution at Leipzig, Germany, and in time they were reforwarded with the German exchanges to the Smithsonian Institution. This arrangement caused a duplication of work and was not in accordance with the conditions of the Brussels treaty.

I therefore suggested that it would be preferable to send future Swiss contributions direct to New York, prepaying freight thereon to that port in the same manner as the Smithsonian sent this country's exchanges for Switzerland to the port of Hamburg free of expense. Dr. Gurtner informed me that there would be no objection to making this change, and I am pleased to report that the new arrangement has already gone into effect, the last consignment from Bern being sent direct to New York.

"The gracious compliance with my requests in other cities for copies of their municipal publications was repeated in Bern, and the volumes which I asked for are expected soon. The official publications of the Swiss Federation will, however, be delayed for a time on account of the fact that each of the twenty-two cantons of which the confederation is composed retains, by law, certain rights concerning the publication and distribution of official documents and each cantonal council must act upon the request which will be made to it from Bern.

"Although the population of Switzerland is small in comparison with some of the countries of Europe, it is relatively among the foremost patrons of the International Exchange Service.

"The French bureau has improved its methods so materially since my visit to Paris in 1897, and especially so since the Secretary had an interview with Monsieur Liard, chief of the libraries of France, last summer, that I did not think it advisable, or, in fact, necessary, to make any suggestions to the director of the bureau. I called, however, as a matter of courtesy.

"Throughout my entire journey, wherever it was necessary for me to ask the official assistance of the consular officers of the United States, and in the case of my call at the embassy in Paris, I was, without exception, offered every facility at the command of this Government's representatives abroad to aid me in accomplishing the work prescribed in my official instructions.

"I returned to the Institution on August 28, having been absent from Washington three months and fourteen days.

"Very respectfully, yours,

"W. I. ADAMS, *Chief Clerk.*"

"Mr. S. P. LANGLEY,

"*Secretary, Smithsonian Institution.*"

*Tabular statement of the work of the International Exchange Service during the fiscal year 1900-1901.*

Date.	Number of packages handled.	Weight of packages handled.	Number of correspondents June 30, 1901.				Packages sent to domestic addresses.	Cases shipped abroad.
			Foreign societies.	Domestic societies.	Foreign individuals.	Domestic individuals.		
1900.								
July .....	10,921	30,802						
August .....	8,858	21,865						
September .....	5,569	13,433						
October .....	10,943	40,973						
November .....	12,337	37,224						
December .....	7,472	31,798						
1901.								
January .....	10,627	35,540						
February .....	7,479	23,828						
March .....	7,401	18,205						
April .....	18,428	53,256						
May .....	12,294	77,010						
June .....	8,721	30,343						
Total .....	121,060	414,277	11,295	2,996	16,261	5,153	31,367	1,757
Increase over 1899-1900 ...	7,497	4,286	450	275	876	153	2,742	111

<sup>1</sup> Decrease.

The following table shows the number of packages of exchanges handled and the increase in the number of correspondents each year from 1894 to 1901.

	1894-95.	1895-96.	1896-97.	1897-98.	1898-99.	1899-1900	1900-1901
Number of packages received.	107,118	88,878	81,162	81,208	97,835	113,563	121,060
Weight of packages received, pounds .....	326,955	258,731	247,444	301,472	317,883	409,991	414,277
Ledger accounts:							
Foreign societies .....	8,751	8,022	9,114	10,165	10,322	10,845	11,295
Foreign individuals .....	9,609	10,878	12,013	12,378	13,378	15,385	16,261
Domestic societies .....	2,014	2,115	2,445	2,533	2,596	2,721	2,996
Domestic individuals .....	3,034	3,899	4,136	4,382	4,673	5,000	5,153
Packages to domestic addresses	29,111	34,091	23,619	21,057	30,645	28,625	31,367
Cases shipped abroad .....	1,361	1,043	1,300	1,330	1,500	1,768	1,757

## CORRESPONDENTS.

The record of exchange correspondents at the close of the year contained 35,705 addresses, being an increase of 1,754 over the preceding year. The following table gives the number of correspondents in each country and also serves to illustrate the scope of the service:

*Number of correspondents of the International Exchange Service in each country on June 30, 1901.*

Country.	CORRESPONDENTS.			Country.	CORRESPONDENTS.		
	Libraries.	Individuals.	Total.		Libraries.	Individuals.	Total.
AFRICA.				AMERICA (NORTH)—			
Algeria .....	20	28	48	continued.			
Angola .....	1		1	Greenland .....	2		2
Azores .....	5	14	19	Mexico .....	140	138	278
Beira .....		1	1	Newfoundland .....	12	17	29
British East Africa ..	0	1	1	St. Pierre-Miquelon ..	2	2	4
Canary Islands .....	1		1	United States .....	2,996	5,153	8,149
Cape Colony .....	40	71	111	West Indies:			
Cape Verde Islands .....		5	5	Anguilla .....		1	1
Egypt .....	27	51	78	Antigua .....	5	4	9
French Kongo .....		1	1	Bahamas .....	2	10	12
Gambia .....		2	2	Barbados .....	9	10	19
Gold Coast .....		2	2	Bermuda .....	4	13	17
Gorée-Dakar .....		3	3	Buen Ayre .....		1	1
Kongo Free State .....		3	3	Cuba .....	42	81	123
Lagos .....	2	1	3	Curaçao .....	1	4	5
Liberia .....	2	5	7	Dominica .....	2	7	9
Lourenço-Marquez .....		2	2	Grenada .....	2	5	7
Madagascar .....	2	7	9	Guadeloupe .....	2	5	7
Madeira .....	3	3	6	Haiti .....	6	16	22
Mauritius .....	11	7	18	Jamaica .....	13	32	45
Morocco .....		10	10	Martinique .....	2	5	7
Mozambique .....		1	1	Montserrat .....		2	2
Natal .....	13	15	28	Nevis .....		1	1
Orange Free State .....		1	1	Porto Rico .....	4	10	14
Réunion .....	2		2	St. Bartholomew .....		2	2
St. Helena .....	2	2	4	St. Christopher ..	1	4	5
Sierra Leone .....	1	3	4	St. Croix .....	1	2	3
South African Republic	13	10	23	St. Eustatius .....		1	1
Tunis .....	6	7	13	St. Martin .....		2	2
Zanzibar .....		6	6	St. Lucia .....	2	4	6
AMERICA (NORTH).				St. Thomas .....	1	3	4
Canada .....	257	463	720	St. Vincent .....	1	2	3
Central America:				Santo Domingo ..	2	10	12
British Honduras .....	3	7	10	Tobago .....		1	1
Costa Rica .....	25	31	56	Trinidad .....	14	11	25
Guatemala .....	40	53	93	Turks Islands .....	2	5	7
Honduras .....	9	27	36	AMERICA (SOUTH).			
Nicaragua .....	12	35	47	Argentina .....	128	119	247
San Salvador .....	14	11	25	Bolivia .....	16	11	27
				Brazil .....	115	136	251

Number of correspondents of the International Exchange Service in each country  
on June 30, 1901—Continued.

Country	CORRESPONDENTS.			Country.	CORRESPONDENTS.		
	Libraries.	Individuals.	Total.		Libraries.	Individuals.	Total.
AMERICA (SOUTH)— continued.				AUSTRALASIA— continued.			
British Guiana .....	14	9	23	Tasmania .....	16	17	33
Chile .....	76	80	156	Victoria .....	86	117	203
Colombia .....	32	47	79	Westerp Australia...	16	22	38
Dutch Guiana .....	3	2	5	EUROPE.			
Ecuador .....	13	20	33	Austria .....	665	920	1,585
Falkland Islands.....		6	6	Belgium.....	314	354	668
French Guiana.....	1	2	3	Bulgaria .....	13	14	27
Paraguay.....	14	9	23	Denmark.....	102	152	254
Peru.....	36	58	94	France .....	1,559	1,840	3,399
Uruguay .....	39	25	64	Germany.....	2,234	2,990	5,224
Venezuela.....	32	39	71	Gibraltar.....		4	4
ASIA.				Great Britain.....	1,872	3,887	5,759
Arabia .....		7	7	Greece .....	38	36	74
Borneo .....		1	1	Iceland.....	16	8	24
British Burma .....	7		7	Italy .....	751	759	1,510
British North Borneo.....		1	1	Luxemburg .....	9	3	12
Celebes.....		1	1	Malta .....	8	12	20
Ceylon .....	21	11	32	Netherlands.....	184	244	428
China .....	41	82	123	Norway .....	118	123	241
Cochin China.....	4		4	Portugal.....	98	70	168
Cyprus .....		3	3	Roumania.....	30	55	85
Formosa.....		1	1	Russia.....	442	690	1,132
French East Indies..	1	1	2	Servia .....	19	13	32
Hongkong.....	7	20	27	Spain.....	162	161	323
India.....	198	183	381	Sweden .....	165	289	454
Japan .....	119	282	401	Switzerland.....	316	508	824
Java.....	17	27	44	Turkey .....	33	70	103
Korea .....	1	6	7	POLYNESIA.			
New Guinea.....		1	1	Bismarck Archipel- ago.....		1	1
Persia .....	3	8	11	Fiji Islands.....	1	3	4
Philippine Islands ..	9	13	22	Hawaiian Islands ..	23	40	63
Portuguese India....	1		1	Marshall Islands ..		1	1
Sarawak.....	1		1	New Caledonia.....		2	2
Siam .....	4	15	19	New Hebrides.....	1		1
Straits Settlements ..	10	12	22	Samoa.....		5	5
Sumatra .....		3	3	Tahiti .....		3	3
AUSTRALASIA.				Tonga .....		2	2
New South Wales....	80	113	193	International .....	34		34
New Zealand .....	69	84	153	Total .....	14,291	21,414	35,705
Queensland .....	33	46	79				
South Australia .....	40	62	102				

## EXCHANGE OF GOVERNMENT DOCUMENTS.

The following table shows the number of packages forwarded and received by the several branches of this Government during the year. By comparison with the last report it will be observed that there has been a slight increase in the number of packages transmitted abroad and an increase of 5 per cent in the number of packages received. The contributions credited to the Library of Congress were forwarded in accordance with the act of Congress approved March 2, 1867.

*Statement of Government exchanges during the year 1899-1900.*

Name of bureau.	Packages.		Name of bureau.	Packages.	
	Re- ceived for—	Sent by—		Re- ceived for—	Sent by—
American Historical Association.....	8	20	Hydrographic Office.....	163	.....
Astrophysical Observatory.....	6	5	Interstate Commerce Com- mission.....	19	297
Auditor for the State and other Departments, Treas- ury Department.....		843	Isthmian Canal Commission.....		1
Board on Geographic Names.....		208	Library of Congress.....	7,015	24,370
Bureau of American Eth- nology.....	224	1,320	Life-Saving Service.....	3	104
Bureau of American Repub- lics.....	10	13	Light-House Board.....	4	115
Bureau of Education.....	88		Marine-Hospital Service.....	14	104
Bureau of Medicine and Surgery.....	1		National Academy of Sci- ences.....	88	36
Bureau of the Mint.....	11	397	National Museum.....	316	3,029
Bureau of Navigation.....	14	18	National Zoological Park...	6	.....
Bureau of Statistics, Treas- ury Department.....	71	4,360	Nautical Almanac Office....	34	161
Bureau of Steam Engineer- ing, Navy Department....	1		Naval Observatory.....	138	675
Census Office.....	19		Navy Department.....	21	1
Civil Service Commission....	7		Office of the Chief of Engi- neers.....	29	124
Coast and Geodetic Survey....	103	828	Office of Indian Affairs.....	6	.....
Commissioners of the Dis- trict of Columbia.....	2	13	Ordnance Office, War De- partment.....	2	.....
Comptroller of the Currency..	5	11	Patent Office.....	102	1,253
Department of Agriculture..	1,096	5	President of the United States.....	2	.....
Department of the Interior..	23	565	Record and Pension Office, War Department.....		162
Department of Justice.....	3		Senate of the United States..		1
Department of Labor.....	37	96	Smithsonian Institution....	2,147	4,157
Department of State.....	13	10	Superintendent of Docu- ments.....	1	134
Entomological Commission..	2		Surgeon-General's Office (Army).....	159	290
Fish Commission.....	85	327	Treasury Department.....	6	8
General Land Office.....	6		War Department.....	62	151
Geological Survey.....	602	4,062	Weather Bureau.....	129	1,136
			Total.....	12,904	49,410

## RELATIVE INTERCHANGE OF PUBLICATIONS BETWEEN THE UNITED STATES AND OTHER COUNTRIES.

Following is a comparative statement of exchange transmissions by packages between the United States and other countries during the years 1900 and 1901:

*Comparative statement of packages received for transmission through the International Exchange Service during the fiscal years ending June 30, 1900 and June 30, 1901.*

Country.	1900.		1901.	
	Packages.		Packages.	
	For—	From—	For—	From—
Algeria .....	96	8	113	74
Angola.....			3	
Antigua.....	8		7	
Arabia.....	3		5	
Argentina.....	3,127	308	2,374	392
Austria-Hungary.....	4,387	2,125	4,531	2,518
Azores.....	6		14	
Bahamas.....	8		15	
Barbados.....	7	1	14	
Belgium.....	2,148	1,564	2,301	1,792
Bermudas.....	27		11	
Bolivia.....	79		84	
Borneo.....			4	
Brazil.....	1,385	803	1,440	715
British America.....	2,479	1,396	2,532	706
British Burma.....	1	1	4	
British Guiana.....	51		57	1
British Honduras.....	5		12	
Bulgaria.....	63	1	72	88
Canary Islands.....			6	
Celebes.....			1	
Cape Colony.....	210	8	274	1
Cape Verde Islands.....			2	
Ceylon.....	49		56	
Chile.....	1,106	211	1,090	1
China.....	238	173	249	141
Colombia.....	704	14	657	
Costa Rica.....	922	478	784	673
Cuba.....	196	22	233	25
Curaçao.....	1		4	
Cyprus.....	1		2	
Denmark.....	1,067	266	1,054	186
Dominica.....	2		5	
Dutch Guiana.....	4		7	
Ecuador.....	71		77	
Egypt.....	96		163	
Falkland Islands.....	1		3	
Fiji Islands.....	3		3	

*Comparative statement of packages received for transmission through the International Exchange Service, etc.—Continued.*

Country.	1900.		1901.	
	Packages,		Packages.	
	For—	From—	For—	From—
Formosa .....	1		2	
France .....	7, 178	3, 458	8, 037	2, 525
French Cochin China .....	1		1	
French Guiana .....			1	
Germany .....	12, 576	6, 139	14, 868	8, 265
Gibraltar .....	2			
Grenada .....	6		4	
Great Britain and Ireland .....	10, 843	8, 950	12, 394	8, 606
Greece .....	2, 037		689	
Greenland .....	2		3	
Guadeloupe .....	2		5	
Guatemala .....	144		129	
Guinea .....			3	
Haiti .....	565		510	
Hawaiian Islands .....	71	8	94	
Honduras .....	41	267	51	23
Hongkong .....	82		76	
Iceland .....	35	1	44	1
India .....	1, 371	154	1, 410	159
Italy .....	3, 862	992	4, 340	1, 275
Jamaica .....	76		90	
Japan .....	1, 391	20	1, 533	18
Java .....	151	121	203	144
Korea .....	19		20	
Lagos .....	1			
Liberia .....	32		42	
Luxemburg .....	55		75	
Madagascar .....	11		12	
Madeira .....	1		5	
Malta .....	35		23	2
Martinique .....	3		3	
Mauritius .....	37		47	
Mexico .....	1, 641	4, 099	1, 719	3, 720
Montenegro .....	1			
Montserrat .....			1	
Morocco .....	1		4	
Natal .....	46	5	58	3
Netherlands .....	1, 662	533	1, 847	723
Nevis .....			1	
New Caledonia .....	1			
Newfoundland .....	37		27	
New Hebrides .....	1			
New South Wales .....	1, 390	360	1, 534	229
New Zealand .....	834	5	821	12
Nicaragua .....	51		58	
Norway .....	1, 237	383	1, 292	999
Paraguay .....	39	13	73	40



*Comparative statement of packages received for transmission through the International Exchange Service, etc.—Continued.*

Country.	1900.		1901.	
	Packages.		Packages.	
	For—	From—	For—	From—
Persia.....	22	.....	20	.....
Peru.....	724	25	723	15
Philippine Islands.....	58	.....	61	.....
Porto Rico.....	10	.....	46	.....
Portugal.....	912	.....	914	.....
Queensland.....	814	.....	814	.....
Reunion.....	7	.....	6	.....
Roumania.....	189	101	175	87
Russia.....	2,951	779	3,213	2,277
St. Bartholomew.....	1	.....	.....	.....
St. Croix.....	1	.....	2	.....
St. Eustatius.....	.....	.....	1	.....
St. Helena.....	2	.....	6	.....
St. Kitts.....	1	.....	3	.....
St. Martin.....	1	.....	2	.....
St. Pierre and Miquelon.....	.....	.....	2	.....
St. Thomas.....	1	.....	2	.....
St. Vincent.....	3	.....	3	.....
Samoa.....	12	.....	13	.....
Santa Lucia.....	3	.....	2	.....
Santo Domingo.....	7	.....	9	.....
San Salvador.....	53	24	77	7
Servia.....	36	1	38	.....
Siam.....	57	.....	54	.....
Sierra Leone.....	2	.....	2	1
Society Islands.....	1	.....	1	.....
South African Republic.....	594	104	542	.....
South Australia.....	781	39	764	92
Spain.....	1,212	.....	1,219	.....
Straits Settlements.....	34	.....	46	1
Sumatra.....	1	.....	4	.....
Sweden.....	1,916	493	1,909	292
Switzerland.....	2,120	726	2,431	686
Syria.....	11	.....	22	.....
Tasmania.....	644	2	691	2
Tonga.....	26	.....	12	.....
Trinidad.....	77	.....	60	.....
Tunis.....	11	.....	15	1
Turkey.....	621	.....	589	.....
Turks Islands.....	2	.....	6	.....
United States.....	28,625	76,264	31,367	81,310
Uruguay.....	817	116	817	129
Venezuela.....	699	1	660	.....
Victoria.....	1,101	517	1,190	312
West Australia.....	790	.....	656	335
Zanzibar.....	2	.....	3	.....

The following is a list of the Smithsonian correspondents acting as distributing agents, or receiving publications for transmission to the United States, and of countries receiving regularly exchanges through the Institution:

- Algeria. (*See France.*)  
 Angola. (*See Portugal.*)  
 Argentina: Museo Nacional, Buenos Ayres.  
 Austria: K. K. Statistische Central-Commission, Wien.  
 Azores. (*See Portugal.*)  
 Belgium: Commission Belge des Échanges Internationaux, Brussels.  
 Bolivia: Oficina Nacional de Inmigración, Estadística y Propaganda Geográfica, La Paz.  
 Brazil: Bibliotheca Nacional, Rio de Janeiro.  
 British Colonies: Crown Agents for the Colonies, London, England.  
 British Guiana. (*See British Colonies.*)  
 British Honduras. (*See British Colonies.*)  
 Bulgaria: Dr. Paul Leverkühn, Sofia.  
 Canada: Packages sent by mail.  
 Canary Islands. (*See Spain.*)  
 Cape Colony: Superintendent of the Stationery Department, Cape Town.  
 Chile: Universidad de Chile, Santiago.  
 China. (Shipments suspended for the present.)  
 Colombia: Biblioteca Nacional, Bogotá.  
 Costa Rica: Oficina de Depósito, Reparto y Canje Internacional, San José.  
 Cuba: Dr. Vicente de la Guardia, Habana.  
 Denmark: Kong. Danske Videnskabernes Selskab, Copenhagen.  
 Dutch Guiana: Surinaamsche Koloniale Bibliotheek, Paramaribo.  
 Ecuador: Biblioteca Nacional, Quito.  
 East India: India Store Department, India Office, London.  
 Egypt: Société Khédiviale de Géographie, Cairo.  
 Fiji Islands. (*See British Colonies.*)  
 France: Bureau Français des Échanges Internationaux, Paris.  
 Friendly Islands: Packages sent by mail.  
 Germany: Dr. Felix Flügel, Wilhelmstrasse 14, Leipzig-Gohlis.  
 Gold Coast. (*See British Colonies.*)  
 Great Britain and Ireland: William Wesley & Son, 28 Essex street, Strand, London, England.  
 Greece: Prof. R. B. Richardson, Director, American School of Classical Studies, Athens.  
 Greenland. (*See Denmark.*)  
 Guadeloupe. (*See France.*)  
 Guatemala: Instituto Nacional de Guatemala, Guatemala.  
 Guinea. (*See Portugal.*)  
 Haiti: Secrétaire d'Etat des Relations Extérieures, Port au Prince.  
 Hawaiian Islands: Foreign Office, Honolulu.  
 Honduras: Biblioteca Nacional, Tegucigalpa.  
 Hungary: Dr. Joseph von Körösy, "Redoute," Budapest.  
 Iceland. (*See Denmark.*)  
 Italy: Biblioteca Nazionale Vittorio Emanuele, Rome.

- Jamaica. (*See* British Colonies.)  
Java. (*See* Netherlands.)  
Korea: Packages sent by mail.  
Leeward Islands. (*See* British Colonies.)  
Liberia: Care of American Colonization Society, Washington, District of Columbia.  
Luxemburg. (*See* Germany.)  
Madagascar. (*See* France.)  
Madeira. (*See* Portugal.)  
Malta. (*See* British Colonies.)  
Mauritius. (*See* British Colonies.)  
Mexico: Packages sent by mail.  
Mozambique. (*See* Portugal.)  
Natal: Agent-General for Natal, London, England.  
Netherlands: Bureau Scientifique Central Néerlandais, Den Helder.  
New Guinea. (*See* Netherlands.)  
New Hebrides: Packages sent by mail.  
Newfoundland: Packages sent by mail.  
New South Wales: Government Board for International Exchanges, Sydney.  
New Zealand: Colonial Museum, Wellington.  
Nicaragua: Ministerio de Relaciones Exteriores, Managua.  
Norway: Kongelige Norske Frederiks Universitet, Christiania.  
Paraguay: Care Consul-General of Paraguay, Washington, District of Columbia.  
Persia. (*See* Russia.)  
Peru: Biblioteca Nacional, Lima.  
Philippine Islands: Packages sent by mail.  
Portugal: Bibliotheca Nacional, Lisbon.  
Queensland: Chief Secretary's Office, Brisbane.  
Roumania. (*See* Germany.)  
Russia: Commission Russe des Échanges Internationaux, Bibliothèque Impériale Publique, St. Petersburg.  
Saint Helena. (*See* British Colonies.)  
Santo Domingo: Packages sent by mail.  
San Salvador: Museo Nacional, San Salvador.  
Servia. (*See* Germany.)  
Siam: Board of Foreign Missions of the Presbyterian Church, New York.  
South African Republic: William Wesley & Son, 28 Essex street, Strand, London.  
South Australia: Astronomical Observatory, Adelaide.  
Spain: Oficina para el Canje de Publicaciones Oficiales, Científicas y Literarias. Sección de Propiedad Intelectual del Ministerio de Fomento, Madrid.  
Straits Settlements. (*See* British Colonies.)  
Sumatra. (*See* Netherlands.)  
Syria: Board of Foreign Missions of the Presbyterian Church, New York.  
Sweden: Kongliga Svenska Vetenskaps Akademien, Stockholm.  
Switzerland: Bibliothèque Fédérale, Berne.

Tasmania: Royal Society of Tasmania, Hobart.

Trinidad. (*See British Colonies.*)

Tunis. (*See France.*)

Turkey: American Board of Commissioners for Foreign Missions, Boston, Massachusetts.

Turks Islands. (*See British Colonies.*)

Uruguay: Oficina de Depósito, Reparto y Canje Internacional, Montevideo.

Venezuela: Biblioteca Nacional, Carácas.

Victoria: Public Library, Museum, and National Gallery, Melbourne.

Western Australia: Victoria Public Library, Perth.

Zanzibar: Packages sent by mail.

The distribution of exchanges to foreign countries was made in 1,757 cases, 282 of which contained official documents for authorized depositories, and the contents of 1,475 cases consisted of Government and other publications for miscellaneous correspondents. Of the latter class of exchanges the number of cases sent to each country is given below.

Argentina .....	30	New South Wales.....	15
Austria.....	64	Netherlands.....	40
Belgium.....	49	New Zealand.....	7
Bolivia.....	2	Nicaragua.....	3
Brazil.....	25	Norway.....	25
British Colonies.....	13	Paraguay.....	2
Cape Colony.....	2	Peru.....	10
China.....	4	Polynesia.....	( <sup>2</sup> )
Chile.....	15	Portugal.....	18
Colombia.....	6	Queensland.....	10
Costa Rica.....	6	Roumania.....	( <sup>4</sup> )
Cuba.....	2	Russia.....	62
Denmark.....	21	Salvador.....	3
Dutch Guiana.....	( <sup>1</sup> )	Santo Domingo.....	1
East India.....	18	Servia.....	( <sup>4</sup> )
Egypt.....	2	Siam.....	( <sup>2</sup> )
France and Colonies.....	164	South Australia.....	8
Germany.....	248	South African Republic.....	( <sup>3</sup> )
Great Britain and Ireland.....	330	Spain.....	19
Greece.....	1	Sweden.....	43
Guatemala.....	2	Switzerland.....	43
Haiti.....	( <sup>2</sup> )	Syria.....	2
Honduras.....	1	Tasmania.....	( <sup>3</sup> )
Hungary.....	25	Turkey.....	2
Italy.....	74	Uruguay.....	8
Japan.....	23	Venezuela.....	7
Mexico.....	( <sup>2</sup> )	Victoria.....	10
Natal.....	( <sup>3</sup> )	Western Australia.....	10

<sup>1</sup> Included in transmissions to Netherlands.

<sup>2</sup> Packages sent by mail.

<sup>3</sup> Included in transmissions to Great Britain.

<sup>4</sup> Included in transmissions to Germany.

The following is a list of depositories of regular sets of United States Government publications forwarded abroad through the International Exchange Service on July 10, October 6, November 23, 1900, and on January 23, April 1, and May 20, 1901:

- Argentina: Library of the Foreign Office, Buenos Ayres.  
 Austria: K. K. Statistische Central-Commission, Wien.  
 Baden: Universitäts-Bibliothek, Freiburg.  
 Bavaria: Königliche Hof-und Staats-Bibliothek, München.  
 Belgium: Bibliothèqne Royale, Brussels.  
 Brazil: Bibliotheca Nacional, Rio de Janeiro.  
 Buenos Ayres: Library of the Government of the Province of Buenos Ayres, La Plata.  
 Canada: Parliamentary Library, Ottawa.  
 Canada: Legislative Library, Toronto.  
 Chile: Biblioteca del Congreso, Santiago.  
 Colombia: Biblioteca Nacional, Bogotá.  
 Costa Rica: Oficina de Depósito, Reparto y Canje Internacional, San José.  
 Denmark: Kongelige Bibliotheket, Copenhagen.  
 England: British Museum, London.  
 France: Bibliothèqne Nationale, Paris.  
 Germany: Deutsche Reichstags-Bibliothek, Berlin.  
 Greece: National Library, Athens.  
 Haiti: Secrétaire d'Etat des Relations Extérieures, Port au Prince.  
 Hungary: Hungarian House of Delegates, Budapest.  
 India: Secretary to the Government of India, Calcutta.  
 Italy: Biblioteca Nazionale Vittorio Emanuele, Roma.  
 Japan: Foreign Office, Tokyo.  
 Mexico: Museo Nacional, Mexico.  
 Netherlands: Library of the States General, The Hague.  
 New South Wales: Government Board for International Exchanges, Sydney.  
 New Zealand: General Assembly Library, Wellington.  
 Norway: Departementet for det Indre, Christiania.  
 Peru: Biblioteca Nacional, Lima.  
 Portugal: Bibliotheca Nacional, Lisbon.  
 Prussia: Königliche Bibliothek, Berlin.  
 Queensland: Parliamentary Library, Brisbane.  
 Russia: Imperial Public Library, St. Petersburg.  
 Saxony: Königliche Bibliothek, Dresden.  
 South African Republic: Department of Foreign Affairs, Pretoria.<sup>1</sup>  
 South Australia: Parliamentary Library, Adelaide.  
 Spain: Seccion de Propiedad Intelectual del Ministerio de Fomento, Madrid.  
 Sweden: Kongliga Biblioteket, Stockholm.  
 Switzerland: Bibliothèqne Fédérale, Berne.  
 Tasmania: Parliamentary Library, Hobart.

<sup>1</sup>Shipments subsequent to August 1, 1899, suspended.

Turkey: Minister of Public Instruction, Constantinople.

Uruguay: Oficina de Depósito, Reparto y Canje Internacional de Publicaciones, Montevideo.

Venezuela: Biblioteca Nacional, Carácas.

Victoria: Public Library, Melbourne.

Western Australia: Victoria Public Library, Perth.

Württemberg, Königliche Bibliothek, Stuttgart.

Respectfully submitted.

F. W. HODGE,

*Acting Curator of Exchanges.*

MR. S. P. LANGLEY,

*Secretary of the Smithsonian Institution.*

APPENDIX IV.

REPORT OF THE SUPERINTENDENT OF THE NATIONAL  
ZOOLOGICAL PARK.

SIR: I have the honor to herewith submit the following report relating to the condition and operations of the National Zoological Park for the year ending June 30, 1901:

At the close of that period the approximate value of the property belonging to the park was as follows:

Buildings for animals .....	\$63,000
Buildings for administrative purposes .....	14,000
Office furniture, books, apparatus, etc. ....	4,000
Machinery, tools, and implements .....	2,200
Fences and outdoor inclosures .....	25,000
Roadways, bridges, paths, rustic seats, etc .....	74,000
Nurseries .....	1,000
Horses.....	800
Animals in zoological collection .....	36,000

A detailed list of the animals in the collection is appended hereto. They may be classified as follows:

	Indige- nous.	Foreign.	Domesti- cated.	Total.
Mammals.....	382	77	78	537
Birds.....	129	40	56	225
Reptiles.....	91	25	.....	116
Total.....	602	142	134	878

The accessions of animals during the year have been as follows:

Presented .....	131
Purchased and collected .....	104
Lent.....	9
Received in exchange.....	28
Born in National Zoological Park .....	46
Total .....	318

The cost for purchase, collection, and transportation of these accessions has been \$4,000. Besides this there has been spent for books, photographs, apparatus, and office furniture the sum of \$1,100.

The appropriation for the National Zoological Park for the fiscal year 1901 was as follows:

For continuing the construction of roads, walks, bridges, water supply, sewerage and drainage; and for grading, planting, and otherwise improving the grounds; erecting and repairing buildings and inclosures; care, subsistence, purchase, and transportation of animals, including salaries or compensation of all necessary employees; the purchase of necessary books and periodicals, and general incidental expenses not otherwise provided for, seventy-five thousand dollars; one-half of which sum shall be paid from the revenues of the District of Columbia and the other half from the Treasury of the United States; and of the sum hereby appropriated five thousand dollars shall be used for continuing the entrance into the Zoological Park from Cathedral avenue and opening driveway into Zoological Park, including necessary grading and removal of earth: *Provided*, That the unexpended balance of the amounts, aggregating eight thousand dollars, heretofore appropriated for widening, grading, and regulating Adams Mill road from Columbia road to the Zoological Park entrance is hereby reappropriated, to be expended under the direction of the Commissioners of the District of Columbia; and that the control of Adams Mill road is hereby vested in the said Commissioners, and all proceedings necessary to purchase or condemn the land necessary to widen said road as authorized by act approved March third, eighteen hundred and ninety-nine, providing for sundry civil expenses of the Government for the fiscal year ending June thirtieth, nineteen hundred, and for other purposes, shall be taken by said Commissioners. (Sundry civil act, June 6, 1900.)

From this the following improvements have been made in the buildings and grounds during the year:

*Temporary bird house.*—A much-needed structure to accommodate struthion and other large birds. As it was deemed inadvisable to expend money for a permanent structure at this time, a cheap frame construction was used, the sides of which were treated with pebble-dash and the roof made of asphalted felt covered with crushed slag. The interior work of the house is better in quality than would be expected from the exterior, the cages being commodious, of good material, with neat finish, and each supplied with direct sunlight from a skylight. It is heated by a steam boiler already in the possession of the park, having been formerly used in the principal animal house. The building being very low is easily heated during winter, but is very hot in summer. Its internal appearance is quite satisfactory, and the birds have been much more healthy since they have been transferred to it. For diving birds two aquarium tanks were introduced, in order that their evolutions under water might be seen by the public. This extremely interesting feature might be enlarged with great advantage. To be effective the water supplying the tanks should be perfectly clear and limpid. This can only be done by means of a good filter. The cost of this bird house was \$3,500.

*Flying cage.*—Another structure relating to birds has been devised and the construction begun during the present year. This is a large flying cage, 158 by 50 by 50 feet. It is intended to supply the cage with running water, and it is hoped that herons and other aquatic species may nest within its limits. The total cost of this structure is estimated at \$6,200, only a portion of which will be expended from the appropriation for 1901.

*The principal animal house.*—The roof of this house was repaired and a portion of it replaced. Additional heating coils were placed at the north end, and the outside range of cages was repainted; all at a total cost of \$500.



*Office building.*—The old building in which the office of the park is placed has been, up to the present time, in a very ruinous state. In order to restore it to something like its pristine condition, the entrance hall and large room connecting with it were finished with a brick floor and suitable windows, the entrance hall on the second floor repaired, one of the chimneys entirely rebuilt, and an extra flue constructed. Several bookcases were built in the library room, furniture was purchased, and several small alterations made to the outside of the building. The total cost of this work was \$2,200.

*Aquarium.*—It being evident that the present temporary aquarium building can be maintained in proper condition but a short time, it was thought necessary to prepare plans for a new and much more satisfactory structure. These plans, which are very elaborate and complete, were prepared by Messrs. Hornblower & Marshall, at a cost of \$500.

*Bridge near Quarry road entrance.*—Under the appropriations for the District of Columbia, Congress made the following appropriation:

For construction of a bridge across Rock Creek on the line of the roadway from Quarry road entrance, under the direction of the Engineer Commissioner of the District of Columbia, twenty-two thousand dollars, one-half of which sum shall be paid out of the revenues of the District of Columbia. (Sundry civil act June 6, 1900.)

In accordance with this provision, a bridge of concrete, made according to the "Melan" system, was constructed in the Zoological Park, taking the place of the wooden bridge of a composite character which was built when the park was first established.

Incidental to the construction of this bridge, the water main that was hung upon the old structure had to be removed and relaid at the bottom of the creek. The cost of this work was \$450, which was defrayed from the appropriation for the National Zoological Park.

*New paddocks.*—Increase of the collection has made it necessary to construct several new paddocks during the year, one being for the Rocky Mountain sheep, another for moose, another for the Newfoundland caribou and mule deer.

It was found necessary to separate the buffalo paddocks by double partitions, in order that the males may not fight through the partition fences.

Water pipes were laid to the camel paddocks, and also to provide pools and shower baths for the bison and other animals during the heated months of summer.

*Repairs to boundary fence.*—The fence which had been removed along the west and south side of the park, to allow grading and improvement of roads in the vicinity, has been reset during the year and a considerable amount of repairs have been made to the fence in other portions of the park. The total cost of these repairs was \$300.

*Macadam walk.*—Many visitors to the park enter from the western side. The board walk which had been constructed to lead from Connecticut Avenue extended to the central portion of the park, through a shady ravine, became so decayed and unsafe that it was necessary to replace it. It was removed and a macadam walk laid. Other walks of less extent were

made where urgently needed. The expenditure for this purpose was about \$700.

*Driveway from Cathedral avenue.*—It will be noted from the language of the appropriation for the park that the entrance formerly specified to be made from Woodley road is now to lead in from Cathedral avenue, a street recently constructed along the western side of the park. An appropriation of \$5,000 was made, which included the necessary grading and removal of earth. In pursuance of this provision of law, work was done on the small dam made over Rock Creek near the site of the old Adams mill in order to secure the banks against high water and to permit the stream to be safely forded. An illustration showing this ford is herewith appended. From this point a fill is being made to connect this driveway with Cathedral avenue. The heavy fill made by the District authorities along the line of Cathedral avenue made it necessary to construct a rude retaining wall at one important point to prevent detritus from washing down and filling up the road. The amount appropriated by the act, \$5,000, has been used upon the driveway, and the work will be continued during the next fiscal year.

The raw slopes of earth that will remain after this driveway is completed should be planted at once with suitable shrubs and trees, in order that they may be kept from serious erosion and to avoid the unsightly appearance which they would otherwise present.

*Repairing roadways.*—The driveway from the Adams mill entrance, which is more used than any other road in the park, has been reshaped and resurfaced with crushed limestone. This driveway assumes additional importance from the fact that the District authorities have at last graded a carriage way from Columbia road to the park entrance, thus making the driveway in the park more easily accessible.

The main driveway throughout the park, from Quarry road to the western entrance, has been dressed with gravel, and the whole at a cost of \$400.

The Klinge road, which skirts the north side of the park, having been repaired and raised by the District authorities, it became necessary to reset the park fence and raise the grade of the driveway connecting with it.

The cutting of Cathedral avenue through the western edge of the park made it necessary to remove a considerable number of evergreen and other trees and shrubs formerly set in that locality for the purpose of a screen. These trees were reset during the hot summer months along the roads and walks in different parts of the park and the shrubs around the office building. Considering the extremely unfavorable weather when the transfer was made, this planting was fairly successful. A considerable amount of stock was transferred from the nursery to permanent localities, and the care of the natural forest of the park has been continued as necessary. The total cost of this work during the year was \$900.

*Children's room at the Smithsonian Institution.*—A small exhibit of fishes and birds belonging to the National Zoological Park has been installed and maintained in the children's room at the Smithsonian Institution. The total expenditure for this purpose was about \$400.

*Sundial.*—The sundial purchased in London by the Secretary from a previous appropriation was set up on the lawn near the animal house, at a cost of \$100.



FORD IN THE NATIONAL ZOOLOGICAL PARK.

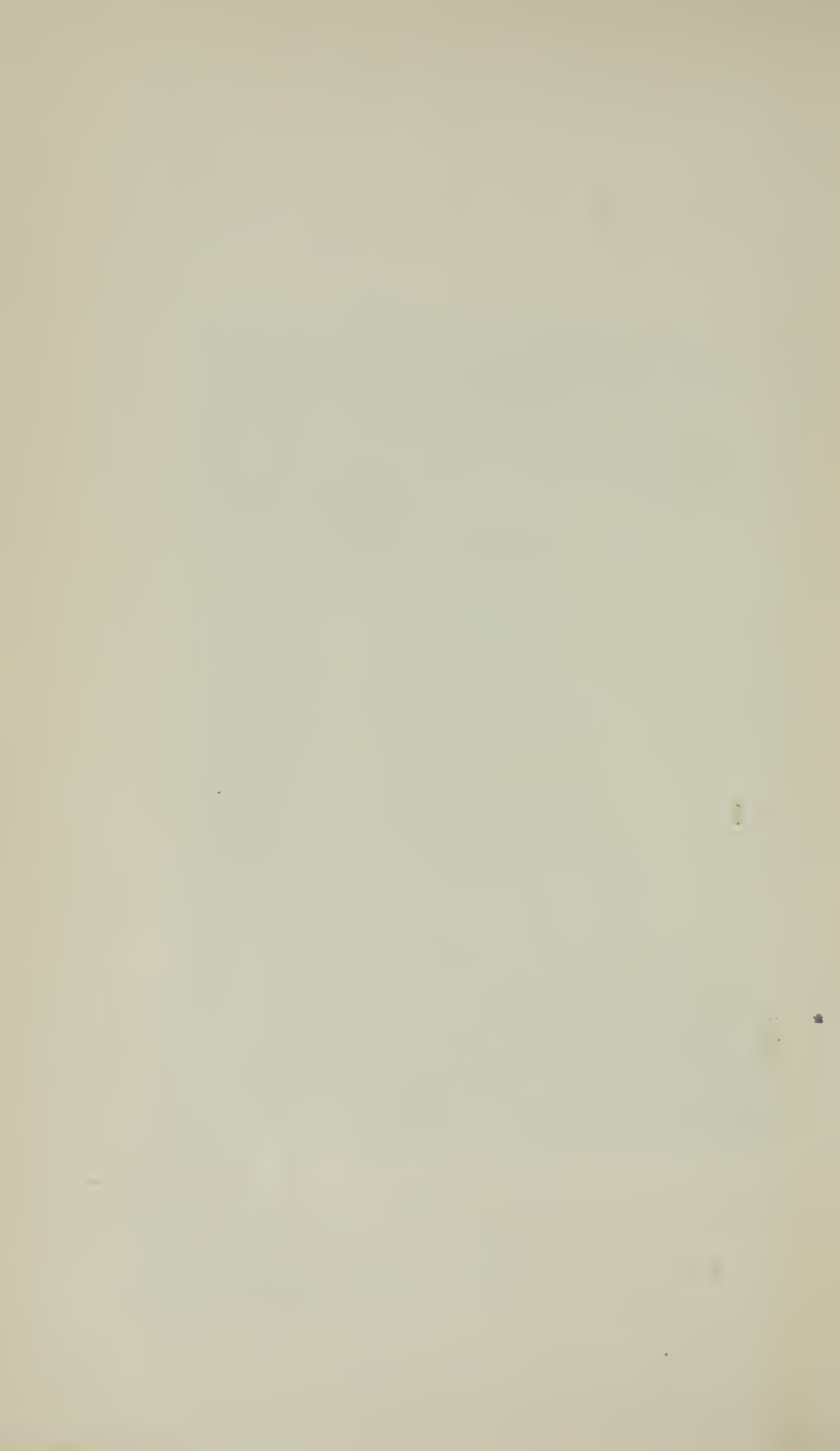





*Gasoline engine and dynamo.*—In the course of certain improvements made at the United States National Museum, it was found that one of the gas engines there used could be dispensed with. It was transferred to the park and adapted for the use of gasoline. The dynamo connected with this engine was also transferred to the park. It will be employed for running lathes and other necessary machinery in the blacksmith and carpenter shop. The total cost of this installation was \$300.

Several important accessions have been made to the collection during the year. Among these are a pair of young lions from Somaliland, Africa, presented by Mr. R. A. Gross, a merchant of Aden; also a pair of young leopards, presented by the Hon. E. S. Cunningham, United States consul at Aden, Arabia. Other animals are expected from this region, but native uprisings in that neighborhood have doubtless prevented further collections.

From Mr. Perry M. De Leon, the United States consul-general at Guayaquil, was received a kinkajou and a coati mundi. Four sloths sent by him unfortunately died en route.

Two Sitka deer, one of which died en route, were presented by Capt. Ferdinand Westdahl, of the United States Coast and Geodetic Survey.

From Miss Helen Hatfield, the daughter of Col. Charles A. P. Hatfield, U. S. A., of Puerto Principe, Cuba, several valuable birds were received, among which were two flamingos, a roseate spoonbill, and an ibis. Two Cuban deer were received from Miss Hatfield and Miss Challie Evans.

A Liberian eagle was presented by Mr. James R. Spurgeon, United States secretary of legation at Monrovia, Liberia.

Mr. E. H. Plumacher, United States consul at Maracaibo, sent a large crocodile. Through some defect of dentition the animal was unable to eat, and died not long after its arrival.

Mr. Solomon Berliner, United States consul at Teneriffe, sent some Lanzarote pigeons.

Four Newfoundland caribou were purchased through the good offices of Mr. Martin J. Carter, the United States consul at St. Johns. A pair of young moose were also obtained through the good offices of Mr. W. H. H. Graham, United States consul at Winnipeg. These, however, died shortly after arrival. Those formerly received from Mr. Graham still remain in the collection. An illustration herewith appended shows the advance in growth of the male moose.

After long and persistent efforts a single Rocky Mountain sheep was obtained from western Colorado. It bore the transportation from its native haunts very well, and is at the present time in good condition. The annexed representation of this interesting animal was made for the park by Mr. M. I. Keller.

Most of the States have now enacted rigid game laws preventing the collection or transportation of mountain sheep, mountain goats, or other rare animals. It seems desirable that this legislation should be so modified as to permit the collection and transportation of animals for the national collection, which was founded with the express object of preserving these rare species.

A specimen of the comparatively rare sea lion of Steller was also purchased.

Capt. Wirt Robinson, U. S. A., and M. W. Lyon, jr., who went to Venezuela in the interest of the United States National Museum, obtained a peccary, three curassows, and four guans.

Messrs. Palmer and Riley, of the National Museum, obtained specimens of Cuban crocodile and several other animals.

In previous reports attention has been called to the urgent need for a new house for elephants and other pachydermatous animals. The present structure is merely a temporary shed, built in an emergency, and expected to last but a few years. It is now in such a condition that it must be strengthened in order to hold up the roof and make it safe for occupation. It is extremely cold in winter, the temperature frequently falling to 40° and even lower. It will have to be sheathed during the present season in order to carry the animals through the next winter. A house suitable for elephants, rhinoceroses, hippopotami, tapirs, and other animals of this character, is considered an essential in all properly equipped zoological gardens, and it would seem to be necessary to erect such a structure before any attempt is made to collect animals of this character. One great disadvantage that the park has always had is that the animals were procured before buildings were ready for them. It would seem wiser to plan and erect the structures and afterward procure the animals for them.

The needs of the park with reference to a suitable bird and reptile house were mentioned in the last annual report. A new structure of this kind should be built in order to keep the animals in proper condition. Many snakes are lost from lack of proper sunlight. It is impossible to keep lizards at all, and it is useless to attempt to exhibit turtles and other reptiles under the conditions at present prevailing.

A large cage for eagles should be built in some suitable locality in the park, as, since this bird has been selected as the national emblem, it would seem that it should be made an especial feature in a national collection. At present these birds are kept in a rickety pen, built of scantling and covered with wire netting. The magnificent harpy eagle from Brazil is confined in the low, temporary bird house, where, in summer, it is extremely hot. There is no suitable cage for the fine Liberian eagle received during the present season. All these birds need a large and commodious cage where there is sufficient room for short flights. Unless this is done they are liable to injure their feet by pounding down upon their perches, and many fine birds have been permanently injured in this manner. A similar cage should also be built for the California condor. This great bird presents a most striking appearance when allowed to spread its vast expanse of wings in flight, but when sitting upon its perch seems much like the minor members of the vulture family. It is expected that several additional specimens of this condor will be received during the coming year.

Another important improvement that should be made is the construction of a suitable pond for sea-lions and seals. The large pond which was constructed for that purpose is found to be altogether too muddy for use by these animals, as when allowed to swim at will in it they soon suffer from sore eyes. They are accommodated at present in small and unsatisfactory basins in the old bear enclosures near the Quarry road entrance.

Besides the losses by death which have been already referred to, several





YOUNG MOUNTAIN SHEEP FROM COLORADO, NATIONAL ZOOLOGICAL PARK.



others should be mentioned. An interesting specimen of Baird's tapir, about three months old, received from Lieut. Roger Welles, jr., U.S. N., died about twenty days after receipt. When received it was suffering from indigestion, and in spite of all efforts it never recovered. Very probably it was taken too young from its mother.

An old bison died from malnutrition, having been sick and feeble for some time. A lioness died as a consequence of difficult parturition. Two Virginia deer were killed by a savage buck, and four mule deer died from some defect of nutrition. The fine zebu bull presented by Mr. Starin, in 1891, finally succumbed, apparently to old age. An old elk and a sea-lion died from the same cause.

Lists of the animals in the park at the close of the fiscal year and of accessions from various sources are hereto appended.

*Animals in National Zoological Park June 30, 1901,*

Name.	Num-ber.	Name.	Num-ber.
MAMMALS.		MAMMALS—continued.	
<i>North American species.</i>		<i>North American species—Continued.</i>	
American bison ( <i>Bison americanus</i> ) . . . . .	11	Gray coatimundi ( <i>Nasua narica</i> ) . . . . .	1
Prong-horn antelope ( <i>Antilocapra americana</i> ) . . . . .	3	Raccoon ( <i>Procyon lotor</i> ) . . . . .	23
Rocky Mountain sheep ( <i>Ovis canadensis</i> ) . . . . .	1	Black bear ( <i>Ursus americanus</i> ) . . . . .	6
Virginia deer ( <i>Odocoileus virginianus</i> ) . . . . .	6	Cinnamon bear ( <i>Ursus americanus</i> ) . . . . .	2
Sitka deer ( <i>Odocoileus columbianus sitkensis</i> ) . . . . .	1	Grizzly bear ( <i>Ursus horribilis</i> ) . . . . .	2
Mule deer ( <i>Odocoileus macrotis</i> ) . . . . .	6	Alaskan bear ( <i>Ursus</i> sp.) . . . . .	1
Cuban deer ( <i>Odocoileus</i> sp.) . . . . .	1	Polar bear ( <i>Thalarectos maritimus</i> ) . . . . .	1
American elk ( <i>Cervus canadensis</i> ) . . . . .	21	California sea lion ( <i>Zalophus californianus</i> ) . . . . .	2
Woodland caribou ( <i>Rangifer caribou</i> ) . . . . .	1	Steller's sea lion ( <i>Eumetopias stelleri</i> ) . . . . .	1
Newfoundland caribou ( <i>Rangifer novæ terræ</i> ) . . . . .	4	Harbor seal ( <i>Phoca vitulina</i> ) . . . . .	4
Moose ( <i>Alces americanus</i> ) . . . . .	2	Common pocket gopher ( <i>Geomys bursarius</i> ) . . . . .	2
Collared peccary ( <i>Tayassu angulatus</i> ) . . . . .	1	California pocket gopher ( <i>Thomomys bottae</i> ) . . . . .	2
Ocelot ( <i>Felis pardalis</i> ) . . . . .	5	American beaver ( <i>Castor canadensis</i> ) . . . . .	4
Puma ( <i>Felis concolor</i> ) . . . . .	1	Hutia-conga ( <i>Capromys pilorides</i> ) . . . . .	11
Spotted lynx ( <i>Lynx rufus maculatus</i> ) . . . . .	2	Woodchuck ( <i>Arctomys monax</i> ) . . . . .	2
Gray wolf ( <i>Canis lupus griseo-albus</i> ) . . . . .	5	Prairie dog ( <i>Cynomys ludovicianus</i> ) . . . . .	63
Black wolf ( <i>Canis lupus griseo-albus</i> ) . . . . .	3	Fox squirrel ( <i>Sciurus niger</i> ) . . . . .	8
Coyote ( <i>Canis latrans</i> ) . . . . .	15	Gray squirrel ( <i>Sciurus cinereus</i> ) . . . . .	31
Red fox ( <i>Vulpes pennsylvanicus</i> ) . . . . .	12	Mountain chipmunk ( <i>Tamias speciosus</i> ) . . . . .	18
Arctic fox ( <i>Vulpes lagopus</i> ) . . . . .	16	Thirteen-lined spermophile ( <i>Spermophilus tridecemlineatus</i> ) . . . . .	13
Swift fox ( <i>Vulpes velox</i> ) . . . . .	6	Kadiak ground squirrel ( <i>Spermophilus empetra kadiakensis</i> ) . . . . .	11
Gray fox ( <i>Urocyon cinereo-argenteus</i> ) . . . . .	1	Beechey's ground squirrel ( <i>Spermophilus grammurus beecheyi</i> ) . . . . .	1
North American otter ( <i>Lutra hudsonica</i> ) . . . . .	3	Yellow-headed ground squirrel ( <i>Spermophilus brevicaudus</i> ) . . . . .	20
American badger ( <i>Taxidea americana</i> ) . . . . .	4	Antelope chipmunk ( <i>Spermophilus leucurus</i> ) . . . . .	2
Kinkajou ( <i>Totos caudirostratus</i> ) . . . . .	2		
American civet cat ( <i>Bassariscus astuta</i> ) . . . . .	2		

## Animals in National Zoological Park June 30, 1901—Continued.

Name.	Number.	Name.	Number.
MAMMALS—continued.		MAMMALS—continued.	
North American species— Continued.		Domesticated and foreign species— Continued.	
Mexican agouti ( <i>Dasyprocta mexi-</i> <i>cana</i> ) .....	2	European hedgehog ( <i>Erinaceus euro-</i> <i>pæus</i> ) .....	1
Northern varying hare ( <i>Lepus</i> <i>americanus</i> ) .....	9	Indian fruit bat ( <i>Pteropus medius</i> ) ..	2
Peba armadillo ( <i>Tatu novemcincta</i> )..	1	Wild boar ( <i>Sus scrofa</i> ) .....	2
Opossum ( <i>Didelphys virginiana</i> ).....	1	Solid-hoofed pig ( <i>Sus scrofa</i> ) .....	1
Domesticated and foreign species.		White-lipped peccary ( <i>Tayassu albi-</i> <i>rostris</i> ).....	1
Purple-faced monkey ( <i>Scelopithicus</i> <i>cephalopterus</i> ).....	1	Zebu ( <i>Bos indicus</i> ) .....	6
Griquet monkey ( <i>Cercopithecus grisco-</i> <i>viridis</i> ) .....	1	Yak ( <i>Poephagus grunniens</i> ) .....	1
Malbrouck monkey ( <i>Cercopithecus</i> <i>cyonurus</i> ).....	1	Barbary sheep ( <i>Ovis tragelaphus</i> )....	1
Green monkey ( <i>Cercopithecus calli-</i> <i>trichus</i> ) .....	1	Common goat ( <i>Capra hircus</i> ) .....	5
Macaque monkey ( <i>Macacus cyno-</i> <i>molgus</i> ) .....	7	Cashmere goat ( <i>Capra hircus</i> ).....	6
Bonnet monkey ( <i>Macacus sinicus</i> ) ..	1	Nylghai ( <i>Bosclaphus tragocamelus</i> ) ..	2
Pig-tailed monkey ( <i>Macacus nemes-</i> <i>trinus</i> ).....	1	Indian antelope ( <i>Antilope cervicapra</i> )	2
Moore macaque ( <i>Macacus maurus</i> )..	1	Sambur deer ( <i>Cervus aristotelis</i> ) .....	1
Black ape ( <i>Cynopithecus niger</i> ) .....	1	Philippine deer ( <i>Cervus philippinus</i> )	1
Black spider-monkey ( <i>Ateles ater</i> )..	1	Fallow deer ( <i>Dama vulgaris</i> ) .....	1
Apella monkey ( <i>Cebus apella</i> ).....	1	Common camel ( <i>Camelus dromeda-</i> <i>rius</i> ).....	3
Capuchin ( <i>Cebus capucinus</i> ).....	4	Bactrian camel ( <i>Camelus bactrianus</i> )..	2
Cebus, undetermined .....	1	Llama ( <i>Auchenia glama</i> ).....	6
Lion ( <i>Felis leo</i> ) .....	5	South American tapir ( <i>Tapirus amer-</i> <i>icanus</i> ) .....	1
Tiger ( <i>Felis tigris</i> ).....	2	Indian elephant ( <i>Elephas indicus</i> )..	1
Leopard ( <i>Felis pardus</i> ) .....	2	Crested agouti ( <i>Dasyprocta cristata</i> )..	1
Spotted hyena ( <i>Hyæna crocuta</i> ) .....	2	Hairy-rumped agouti ( <i>Dasyprocta</i> <i>prymnolopha</i> ) .....	1
Wolf hound .....	1	Azara's agouti ( <i>Dasyprocta azarae</i> )..	2
St. Bernard dog.....	1	Acouchy ( <i>Dasyprocta acouchy</i> ).....	5
Pointer .....	1	Golden agouti ( <i>Dasyprocta aguti</i> )....	2
Chesapeake Bay dog .....	1	Albino rat ( <i>Mus rattus</i> ).....	5
Bedlington terrier.....	1	Crested porcupine ( <i>Hystrix cristata</i> )..	3
Smooth-coated fox terrier.....	3	Guinea pig ( <i>Cavia porcellus</i> ).....	14
Wire-haired fox terrier.....	1	English rabbit ( <i>Lepus cuniculus</i> )....	17
Eskimo dog.....	3	Six-banded armadillo ( <i>Dasyppus sex-</i> <i>cinctus</i> ) .....	1
Mongoose ( <i>Herpestes mungo</i> ) .....	1	Great gray kangaroo ( <i>Macropus</i> <i>giganteus</i> ) .....	3
Tayra ( <i>Galiotis barbara</i> ) .....	1	Brush-tailed rock kangaroo ( <i>Petro-</i> <i>gale penicillata</i> ).....	2
Red coatimundi ( <i>Nasua rufa</i> ).....	2	BIRDS.	
Crab-eating raccoon ( <i>Procyon can-</i> <i>civora</i> ).....	2	Road runner ( <i>Geococcyx californi-</i> <i>anus</i> ) .....	3
Sun bear ( <i>Ursus malayanus</i> ).....	1	Sulphur-crested cockatoo ( <i>Cacatua</i> <i>galcrita</i> ) .....	1
Sloth bear ( <i>Melursus labiatus</i> ) .....	1		

*Animals in National Zoological Park June 30, 1901—Continued.*

Name.	Number.	Name.	Number.
BIRDS—continued.		BIRDS—continued.	
Leadbeater's cockatoo ( <i>Cacatua leadbeateri</i> ) .....	1	Wild turkey ( <i>Melagris gallopavo feras</i> ) .....	2
Roseate cockatoo ( <i>Cacatua roseicapilla</i> ) .....	5	Pea fowl ( <i>Pavo cristatus</i> ) .....	26
Yellow and blue macaw ( <i>Ara araucana</i> ) .....	2	Valley partridge ( <i>Callipepla californica ruficollis</i> ) .....	5
Red and yellow and blue macaw ( <i>Ara macao</i> ) .....	2	Mountain partridge ( <i>Oreortyx pictus</i> ) ..	1
Red and blue macaw ( <i>Ara chloroptera</i> ) .....	1	Sandhill crane ( <i>Grus mexicana</i> ) .....	3
Green parrotlet ( <i>Conurus</i> sp.) .....	2	Whooping crane ( <i>Grus americana</i> ) ..	1
Carolina parrotlet ( <i>Conurus carolinensis</i> ) .....	3	Green heron ( <i>Ardea virescens</i> ) .....	2
Yellow-naped amazon ( <i>Amazona auropalliata</i> ) .....	1	Little blue heron ( <i>Ardea carolinca</i> ) ..	1
White-fronted amazon ( <i>Amazona leucocephala</i> ) .....	3	Great blue heron ( <i>Ardea herodias</i> ) ..	8
Double yellow-head ( <i>Amazona oratrix</i> ) .....	3	Black-crowned night heron ( <i>Nycticorax nycticorax mexicanus</i> ) .....	3
Mealy amazon ( <i>Amazona farinosa</i> ) ..	1	Scarlet ibis ( <i>Guara rubra</i> ) .....	1
Great horned owl ( <i>Bubo virginianus</i> ) ..	12	White ibis ( <i>Guara alba</i> ) .....	2
Barred owl ( <i>Syrnium nebulosum</i> ) .....	7	Boatbill ( <i>Cochlearius cochlearius</i> ) ..	1
Barn owl ( <i>Strix pratensis</i> ) .....	4	Roseate spoonbill ( <i>Ajaja ajaja</i> ) .....	1
Bald eagle ( <i>Haliaeetus leucocephalus</i> ) ..	11	American flamingo ( <i>Phoenicopterus ruber</i> ) .....	2
Harp eagle ( <i>Thrasaetus harpyia</i> ) .....	1	Trumpeter swan ( <i>Olor buccinator</i> ) ..	3
Golden eagle ( <i>Aquila chrysaetos</i> ) .....	2	Whistling swan ( <i>Olor columbianus</i> ) ..	1
Crowned hawk-eagle ( <i>Spizaetus coronatus</i> ) .....	1	Mute swan ( <i>Cygnus gibbus</i> ) .....	2
Red-tailed hawk ( <i>Buteo borealis</i> ) .....	8	Brant ( <i>Branta bernicla</i> ) .....	2
Sharp-shinned hawk ( <i>Accipiter velox</i> ) ..	1	Canada goose ( <i>Branta canadensis</i> ) ..	6
Pigeon hawk ( <i>Fulco columbarius</i> ) .....	1	Hutchins's goose ( <i>Branta canadensis hutchinsii</i> ) .....	1
California condor ( <i>Gymnogyps californianus</i> ) .....	1	Chinese goose ( <i>Anser cygnoides</i> ) .....	2
Turkey vulture ( <i>Cathartes aura</i> ) .....	6	Mandarin duck ( <i>Dendrocygna galericulata</i> ) .....	11
Black vulture ( <i>Catharista atrata</i> ) .....	1	Pintail ( <i>Dafila acuta</i> ) .....	1
King vulture ( <i>Gypagys papa</i> ) .....	1	Pekin duck ( <i>Anas</i> sp.) .....	2
Lanzarotte pigeon ( <i>Columba livia</i> ) .....	1	Mallard duck ( <i>Anas boschas</i> ) .....	1
Ring dove ( <i>Columba palumbus</i> ) .....	7	Common duck ( <i>Anas boschas</i> ) .....	5
Chachalaca ( <i>Ortalis vetula macallii</i> ) .....	2	American tree duck ( <i>Dendrocygna discolor</i> ) .....	1
Red-tailed guan ( <i>Ortalis ruficauda</i> ) ..	2	American white pelican ( <i>Pelecanus erythrorhynchos</i> ) .....	8
Rufous-bellied guan ( <i>Penelope cristata</i> ) .....	3	Brown pelican ( <i>Pelecanus fuscus</i> ) ..	5
Red billed curassow ( <i>Crao carunculata</i> ) .....	1	Florida cormorant ( <i>Phalacrocorax lilophus floridanus</i> ) .....	4
Daubenton's curassow ( <i>Crao daubentoni</i> ) .....	3	Snake bird ( <i>Anhinga anhinga</i> ) .....	2
Lesser razor-billed curassow ( <i>Milua tomentosa</i> ) .....	1	Common rhea ( <i>Rhea americana</i> ) .....	1
		Cassowary ( <i>Casuaris galcalus</i> ) .....	2
		Emu ( <i>Dromaeus nove-hollandiae</i> ) .....	1
		REPTILES.	
		Alligator ( <i>Alligator mississippiensis</i> ) ..	14
		Cuban crocodile ( <i>Crocodilus rhombifer</i> ) .....	4

*Animals in National Zoological Park June 30, 1901—Continued.*

Name.	Number.	Name.	Number.
REPTILES—continued.		REPTILES—continued.	
Painted turtle ( <i>Chrysemys picta</i> ) . . . . .	6	Diamond rattlesnake ( <i>Crotalus adamanteus</i> ) . . . . .	2
Musk turtle ( <i>Aromochelys odorata</i> ) . .	2	Copperhead ( <i>Ancistrodon contortrix</i> ) . .	2
Mud turtle ( <i>Cinosternum pennsylvanicum</i> ) . . . . .	5	Water moccasin ( <i>Ancistrodon piscivorus</i> ) . . . . .	1
Terrapin ( <i>Pseudemys</i> sp.) . . . . .	1	Indian python ( <i>Python molurus</i> ) . . . .	1
Gopher turtle ( <i>Xerobates polyphemus</i> ) . .	1	West African python ( <i>Python sebae</i> ) . .	1
Box tortoise ( <i>Cistudo carolina</i> ) . . . . .	2	Common boa ( <i>Boa constrictor</i> ) . . . . .	13
Three-toed box tortoise ( <i>Cistudo triangularis</i> ) . . . . .	6	Anaconda ( <i>Eumeces murinus</i> ) . . . . .	2
Painted box tortoise ( <i>Cistudo ornata</i> ) . .	5	Bull snake ( <i>Pityophis sayi sayi</i> ) . . . . .	8
Duncan Island tortoise ( <i>Testudo ephippium</i> ) . . . . .	2	Black snake ( <i>Bascanium constrictor</i> ) . .	3
Albemarle Island tortoise ( <i>Testudo vicina</i> ) . . . . .	2	King snake ( <i>Ophibolus getulus</i> ) . . . . .	4
Brazilian tortoise ( <i>Testudo tabulata</i> ) . .	4	Mountain black snake ( <i>Coluber obsoletus</i> ) . . . . .	1
Clouded iguana ( <i>Cyclura carinata</i> ) . . .	1	Garter snake ( <i>Eutania sirtalis</i> ) . . . . .	4
Alligator lizard ( <i>Sceloporus</i> sp.) . . . .	3	Water snake ( <i>Natrix sipedon</i> ) . . . . .	2
Horned lizard ( <i>Phrynosoma cornutum</i> ) . . . . .	3	Hog-nosed snake ( <i>Heterodon platyrhinus</i> ) . . . . .	3
Glass snake ( <i>Ophiosaurus ventralis</i> ) . .	2	Gopher snake ( <i>Spilotes corais cooperii</i> ) . . . . .	2
Gila monster ( <i>Holoderma suspectum</i> ) . .	4		

*List of accessions for the fiscal year ending June 30, 1901.*

## ANIMALS PRESENTED.

Name.	Donor.	Number.
Malbrouck monkey . . . . .	Mrs. A. L. Barber, Washington, D. C. . . . .	1
Black spider monkey . . . . .	Lieut. Roger Welles, jr., U. S. N. . . . .	1
Lion . . . . .	R. A. Gross, Aden, Arabia . . . . .	2
Leopard . . . . .	E. S. Cunningham, United States consul, Aden, Arabia. . . . .	2
Ocelot . . . . .	Rear-Admiral J. G. Walker, U. S. N. . . . .	1
Do . . . . .	Thomas W. Cridler, Third Assistant Secretary of State. . . . .	1
Coyote . . . . .	J. R. Eddy, Washington, D. C. . . . .	2
Red fox . . . . .	Frank G. Sbaible, Freeport, Ill. . . . .	1
Do . . . . .	Edward Fox and John Turnbull, Cazenovia, N. Y. . . . .	2
Do . . . . .	J. D. Hale, Munsonville, N. H. . . . .	2
Do . . . . .	J. D. Watkins, Washington, D. C. . . . .	1
Do . . . . .	Donor unknown . . . . .	1
Gray fox . . . . .	E. A. Newman, Washington, D. C. . . . .	2
Do . . . . .	Raphael Koester, Washington, D. C. . . . .	1
Kinkajou . . . . .	Perry M. De Leon, United States consul-general, Guayaquil, Ecuador. . . . .	1
Coatimundi . . . . .	do . . . . .	1

*List of accessions for the fiscal year ending June 30, 1901—Continued.*

## ANIMALS PRESENTED—Continued.

Name.	Donor.	Number.
Raccoon.....	The President of the United States.....	2
Albino raccoon.....	Donor unknown.....	1
Black bear.....	Mark Lulley, Nogales, Ariz.....	1
Cinnamon bear.....	do.....	1
Harbor seal.....	J. H. Starin, New York.....	6
European hedgehog.....	G. S. Miller, jr., Washington, D. C.....	1
Common goat.....	Charles W. Buhler, Washington, D. C.....	1
Sitka deer.....	Capt. Ferdinand Westdahl, U. S. Coast and Geodetic Survey.....	1
Cuban deer.....	Miss Helen Hatfield and Miss Challie Evans, Puerto Principe, Cuba.....	2
Gray squirrel.....	G. F. Foote, Washington, D. C.....	1
Do.....	Samuel Ross, Washington, D. C.....	1
Do.....	Miss Lockwood, Washington, D. C.....	1
Do.....	R. L. McGuire, Washington, D. C.....	1
Spermophile.....	R. H. Sargent, U. S. Geological Survey.....	4
English rabbit.....	Miss Olga Smolianinoff, Washington, D. C.....	2
Conure.....	Miss Florence Stevens, Washington, D. C.....	1
Do.....	Mrs. Mary O. Clarke, Washington, D. C.....	1
Great horned owl.....	J. P. Miller, Washington, D. C.....	1
Barn owl.....	E. W. Stork, Washington, D. C.....	4
Barred owl.....	W. F. Potts, Washington, D. C.....	1
Do.....	J. C. Yost, Washington, D. C.....	2
Screech owl.....	Clarke Middleton, Washington, D. C.....	2
American osprey.....	A. M. Nicholson, Orlando, Fla.....	1
Pigeon hawk.....	Donor unknown.....	1
Duck hawk.....	N. R. Wood, Washington, D. C.....	1
Bald eagle.....	J. C. P. Kellan, Cape Charles, Va.....	1
Do.....	W. W. Holton, The Plains, Va.....	1
Do.....	E. M. Duncan, Sanibel, Fla.....	2
Liberian eagle.....	J. R. Spurgeon, United States Secretary of Legation, Monrovia, Liberia.....	1
Red-tailed hawk.....	W. R. V. Clayton, Annapolis, Md.....	1
Do.....	Ira Brink and A. D. Avery, Middletown, N. Y.....	1
Do.....	Miss Mabel Keenan, Brentwood, D. C.....	1
Do.....	Mrs. Anderson, Washington, D. C.....	1
Do.....	Donor unknown.....	1
Sharp-shinned hawk.....	Henry and George Marshall, Laurel, Md.....	2
Turkey vulture.....	E. S. Schmid, Washington, D. C.....	1
Lanzarote pigeon.....	Solomon Berliner, United States Consul, Tenerife.....	2
Red-tailed guan.....	E. Shunk, La Guaira, Venezuela.....	1
Night heron.....	A. M. Nicholson, Orlando, Fla.....	1
Little blue heron.....	do.....	1
White ibis.....	Miss Helen Hatfield, Puerto Principe, Cuba.....	1
Do.....	A. M. Nicholson, Orlando, Fla.....	3
Roseate spoonbill.....	Miss Helen Hatfield, Puerto Principe, Cuba.....	1
Flamingo.....	do.....	2
Florida cormorant.....	A. M. Nicholson, Orlando, Fla.....	2

*List of accessions for the fiscal year ending June 30, 1901—Continued.*

ANIMALS PRESENTED—Continued.

Name.	Donor.	Number.
Sharp-nosed crocodile.....	E. H. Plumacher, United States Consul, Maracaibo, Venezuela.	1
Alligator .....	C. A. Niel, Washington, D. C.....	2
Do.....	Mrs. Calders, Washington, D. C.....	1
Do.....	Willis Lanier, Washington, D. C.....	1
Do.....	Capt. John Shaw, Washington, D. C.....	1
Painted box tortoise .....	John H. Britts, Clinton, Mo.....	5
Three-toed box tortoise .....	.....do.....	6
Horned lizard .....	E. Meyenberg, Pecos, Tex.....	3
Alligator lizard.....	.....do.....	2
Gila monster .....	W. W. Wilson, Florence, Ariz.....	1
Glass snake .....	John Y. Detwiler, New Smyrna, Fla.....	2
Prairie rattlesnake.....	L. W. Purinton, Banner, Kans.....	1
King snake.....	George Van Gueder, Riverdale, Md.....	1
Black snake.....	R. G. Paine, Washington, D. C.....	1
Do.....	Victor Mindeleff, Washington, D. C.....	1
Do.....	Miss Jessie Roberts, Potomac, Md.....	2
Garter snake.....	E. T. Carrico, Stithton, Ky.....	1
Water snake.....	C. R. Reubin, Washington, D. C.....	1
Hog-nosed snake.....	J. Ashbuch, Jessups, Md.....	1
Do.....	L. W. Purinton, Banner, Kans.....	1
Do.....	F. C. Bostock, Baltimore, Md.....	4
Do.....	E. T. Carrico, Stithton, Ky.....	1
Do.....	R. G. Paine, Washington, D. C.....	1

ANIMALS LENT.

Macaque monkey .....	C. J. Trevitt, Washington, D. C.....	1
Pig-tailed monkey.....	W. P. M. King, Washington, D. C.....	1
Capuchin.....	Thos. W. Cridler, Third Assistant Secretary of State.....	3
Do.....	M. C. Roessle, Washington, D. C.....	1
Red fox .....	T. M. Rudd, Washington, D. C.....	1
Red and blue macaw.....	Thos. W. Cridler, Third Assistant Secretary of State.....	1
Yellow-naped amazon .....	Mrs. A. B. Williams, Washington, D. C.....	1

ANIMALS RECEIVED IN EXCHANGE.

Purple-faced monkey .....	E. S. Schmid, Washington, D. C.....	1
Green monkey .....	Miss Rachel Weems, Upper Falls, Md.....	1
Cebus, undetermined.....	E. S. Schmid, Washington, D. C.....	1
Raccoon.....	.....do.....	3
Black bear .....	.....do.....	1
Indian antelope.....	William Bartels, New York.....	1
Baerian camel.....	F. C. Bostock, Indianapolis, Ind.....	2
Brush-tailed rock kangaroo.....	William Bartels, New York.....	1
Great horned owl .....	E. S. Schmid, Washington, D. C.....	1
Barred owl .....	.....do.....	1



List of accessions for the fiscal year ending June 30, 1901—Continued.

ANIMALS RECEIVED IN EXCHANGE—Continued.

Name.	Donor.	Number.
Bald eagle.....	E. S. Schmid, Washington, D. C.....	1
Red-tailed hawk.....	do.....	1
King vulture.....	F. C. Bostock, Baltimore, Md.....	1
Wild turkey.....	E. S. Schmid, Washington, D. C.....	1
Canada goose.....	do.....	3
Bull snake.....	do.....	8

Animals purchased and collected.

Guinea baboon ( <i>Papio sphinx</i> ).....	1
Ocelot ( <i>Felis pardalis</i> ).....	2
Swift fox ( <i>Vulpes velox</i> ).....	5
American otter ( <i>Lutra hudsonica</i> ).....	3
American badger ( <i>Taxidea americana</i> ).....	2
Cacomistle ( <i>Bassariscus astuta</i> ).....	3
Black bear ( <i>Ursus americanus</i> ).....	2
Cinnamon bear ( <i>Ursus americanus</i> ).....	1
Alaskan bear ( <i>Ursus</i> sp.).....	1
Steller's sea lion ( <i>Eumetopius stelleri</i> ).....	1
Collared peccary ( <i>Tayassu angulatus</i> ).....	3
American bison ( <i>Bison americanus</i> ).....	1
Rocky Mountain sheep ( <i>Ovis canadensis</i> ).....	1
Prong-horn antelope ( <i>Antilocapra americana</i> ).....	1
Virginia deer ( <i>Odocoileus virginianus</i> ).....	1
Mule deer ( <i>Odocoileus macrotis</i> ).....	5
Newfoundland caribou ( <i>Rangifer norve-terra</i> ).....	4
Moose ( <i>Alces americanus</i> ).....	2
Black squirrel ( <i>Sciurus cinereus</i> ).....	1
Richardson's spermophile ( <i>Spermophilus richardsoni</i> ).....	12
Kadiak spermophile ( <i>Spermophilus empetra kadiakensis</i> ).....	11
Canada porcupine ( <i>Erethizon dorsatus</i> ).....	1
Three-toed sloth ( <i>Bradypus tridactylus</i> ).....	1
Great horned owl ( <i>Bubo virginianus</i> ).....	1
Barred owl ( <i>Syrnium nebulosum</i> ).....	1
Bald eagle ( <i>Haliaeetus leucocephalus</i> ).....	1
Red-tailed hawk ( <i>Buteo borealis</i> ).....	1
Black vulture ( <i>Catharista atrata</i> ).....	1
Red-tailed guan ( <i>Ortalis ruficauda</i> ).....	4
Daubenton's curassow ( <i>Crax daubentoni</i> ).....	3
Sandhill crane ( <i>Grus mexicana</i> ).....	1
Great blue heron ( <i>Ardea herodias</i> ).....	5
Emu ( <i>Dromæus novæ-hollandiæ</i> ).....	1
Cuban crocodile ( <i>Crocodylus rhombifer</i> ).....	15
Brazilian tortoise ( <i>Testudo tabulata</i> ).....	4
Common boa ( <i>Boa constrictor</i> ).....	1

*Animals born in the National Zoological Park.*

Lion ( <i>Felis leo</i> ) .....	1
Gray wolf ( <i>Canis lupus griseo-albus</i> ) .....	4
Coyote ( <i>Canis latrans</i> ) .....	5
Blue fox ( <i>Vulpes lagopus</i> ) .....	5
American bison ( <i>Bison americanus</i> ) .....	1
Zebu ( <i>Bos indicus</i> ) .....	1
Cashmere goat ( <i>Capra hircus</i> ) .....	2
Nilghai ( <i>Boselaphus tragocamelus</i> ) .....	1
American elk ( <i>Cervus canadensis</i> ) .....	7
Virginia deer ( <i>Odocoileus virginianus</i> ) .....	1
Mule deer ( <i>Odocoileus macrotis</i> ) .....	1
Llama ( <i>Auchenia glama</i> ) .....	3
Hutia-conga ( <i>Capromys pilorides</i> ) .....	7
Prairie dog ( <i>Cynomys ludovicianus</i> ) .....	5
Acouchy ( <i>Dasyprocta acouchy</i> ) .....	2

## SUMMARY.

Animals on hand July 1, 1900 .....	839
Accessions during the year .....	318
Total .....	1,157
Deduct loss (by exchange, death, and returning of animals) .....	279
On hand June 30, 1901 .....	878

Respectfully submitted.

FRANK BAKER, *Superintendent.*Mr. S. P. LANGLEY,  
*Secretary, Smithsonian Institution.*

## APPENDIX V.

### REPORT OF THE WORK OF THE ASTROPHYSICAL OBSERVATORY FOR THE YEAR ENDING JUNE 30, 1901.

SIR: The kinds and amounts of the Observatory property are approximately as follows:

Buildings .....	\$6, 300
Apparatus.....	31, 300
Library and records.....	5, 600
Total .....	43, 200

During the past year the acquisitions of property of the kinds just enumerated have been as follows:

(a) *Apparatus*.—Astronomical and physical apparatus has been purchased at an expenditure of \$1,300.

(b) *Library and records*.—The usual periodicals have been continued, and various books of reference have been purchased at a total cost of \$200.

Total accessions of property, \$1,500.

The Observatory inclosure has been enlarged to include about 11,000 square feet, as against less than 6,000 square feet formerly. The cost of fencing the grounds as thus enlarged was \$400.

Losses of property have been slight, and consist in the usual wear and tear and breakage of apparatus, amounting in aggregate to \$50.

#### THE WORK OF THE OBSERVATORY.

For convenience the work of the Observatory may be described under the following headings:

1. Publications and miscellaneous work.
2. Progress of investigations.
3. Eclipse expedition to Sumatra.

(1) *Publications and miscellaneous work*.—As was stated in my last year's report, Volume I of *Annals of the Astrophysical Observatory* was then being issued. Owing to difficulty in obtaining satisfactory reproductions of Plate XX, the actual distribution of the edition was delayed while further efforts were made to improve this plate. New copies of it were prepared and submitted to the engravers, and it was only in March and April of the present year that the edition was finally bound up and distributed. In the effort to include as thoroughly as possible the names of those to whom the book would be valuable, considerable time was spent in preparing the mailing list, but it is even yet possible that some persons much interested in astrophysical work may have been overlooked by inadvertence, but as there still remains a part of the edition applications for copies will still be considered here.

Inasmuch as the Aid Acting in Charge is also the custodian of the physical apparatus of the Smithsonian Institution, he was concerned in the fitting up of the new instrument room in the south tower of the Smithsonian building, and in the arrangement of the apparatus there.

A considerable amount of the time of the Junior Assistant was occupied in the preparation of enlarged representations of the holographic results appearing in Volume I of the "Annals" for use by the Secretary in describing these results to various learned societies, and also for exhibition at the Buffalo Exposition.

(2) *Progress of investigations—Adjustment of apparatus.*—From my last year's report it will be apparent to how great an extent the Observatory apparatus was removed to North Carolina for use in observing the solar eclipse of May, 1900. It will therefore be understood that no little time was consumed in again setting up and accurately adjusting the apparatus for work here.

*Radiation of the moon.*—The first observations made were upon the radiation of the moon. These observations, whose general result was given by anticipation in last year's report, in connection with the discussion of the bolometric work on the corona during the eclipse, called renewed attention to the fact, so apparent in your bolometric work at Allegheny, that much the larger proportion of the radiation we receive from the moon is the radiation proper of the lunar soil rather than the direct reflection of solar rays, but that this properly lunar radiation varies exceedingly in amount, depending on the amount of moisture in our atmosphere. Thus the directly reflected portion of the whole lunar radiation received at the earth's surface may vary from 20 to 40 per cent, according as our air is dry or humid. It may be mentioned that certain similar observations made by the Aid Acting in Charge while upon the eclipse expedition to Sumatra indicated that quite 40 per cent of the lunar rays received in that moist climate are those directly reflected from the sun.

*Intramercorial planets.*—Inasmuch as the results of the photographic search for new planets conducted at the eclipse of May, 1900, were fully described in last year's report, it will be unnecessary to refer to them here, more than to say that the comparison and reduction of the eclipse photographs for this purpose really formed part of the work of this present year. It was, however, deemed desirable to again photograph the same region of sky with the lens employed at that eclipse, and apparatus was set up and used for this purpose in January of the present year; but satisfactory results had not been obtained when it became necessary to send the apparatus to Sumatra.

*Galvanometer.*—The sensitive galvanometer mentioned in my last year's report, and from which the greatest usefulness is expected, has absorbed considerable attention; and although progress has not, owing to other occupations, as yet passed beyond an experimental stage, it is yet so satisfactory as to deserve a preliminary notice. By way of introduction attention is drawn to the distinction between the computed sensitiveness of a galvanometer and its actual or working sensitiveness. In the older practice of perhaps twenty years ago the most sensitive galvanometers had needle systems of several hundred milligrams weight, and they were, owing to their great inertia, customarily used with a time of single swing

as great as ten or even twenty seconds. Thus it became customary in describing the sensitiveness of a galvanometer to refer its sensitiveness to a time of single swing of ten seconds. Within the past decade the galvanometer needle systems of highest sensitiveness have become relatively microscopic in size and now frequently weigh no more than *one or two thousandths of a gram (two to four millionths of a pound)*. These systems are often far more sensitive with a time of single swing of only one or two seconds than the best galvanometers of twenty years ago at a time of single swing of twenty seconds. With a needle system practically undamped either by air resistance or induction currents the sensitiveness is proportional to the square of the time of swing, so that the sensitiveness of a needle system at ten seconds single swing would on this basis be a hundred times that which it would have at a one-second swing. Thus it arises that the computed sensitiveness of these light systems runs perhaps thousands of times as great as that of the systems of twenty years ago. But it must not be forgotten that owing to the increased disturbance from mechanical jarring and to the extreme potency of air resistance with these light systems they can not in general be usefully employed at even half so long a time of single swing as ten seconds; and in the second place, if it were indeed possible to use them at a ten-second swing, it would be found that the sensitiveness was perhaps not more than ten instead of a hundred fold greater than at one second. Thus comparisons of sensitiveness based on a ten-second single swing are entirely unfair to the older instruments, which could be and were employed at the time of swing used as the basis of comparison, and hence had a working sensitiveness far more nearly comparable with that of the present day than their computed sensitiveness would indicate. In consequence of this unfairness it has recently become common to speak of the sensitiveness at ten seconds *double* swing, a condition at which galvanometers are now sometimes actually used. At this Observatory this change of the basis of comparison has not heretofore been adopted. It must not be inferred from what has been said that the advance made in the last twenty years in the construction of galvanometers is belittled, for the reduction in the time of swing for the same degree of sensitiveness is a most valuable saving in time and chances of error, and for automatic recording, as in bolographic work, is wholly indispensable.

In the past two years the design of galvanometer needles has been a subject of much investigation both experimental and theoretical at this observatory, and it is believed that the results arrived at mark practically the limit of probable progress in the way of obtaining sensitiveness at a given short time of swing of a needle system. By this I mean that it is improbable that a galvanometer can ever be constructed of a given resistance which when employed at one second time of a single swing shall give very appreciably greater deflections for given currents than will such a galvanometer as can be constructed with the aid of the knowledge now attained here. In other words, the time for increase of computed sensitiveness by tens and hundreds of times with each newly constructed instrument has passed away. In what has been said I do not wish to claim peculiar advantages for our galvanometer, for I understand that both in this country and abroad practically the same results, as regards com-

puted sensitiveness, have recently been reached by several physicists independently, which strengthens the view that little further advance in this direction is likely.

But the useful or working sensitiveness of a galvanometer is another matter, and by the system of support and magnetic shielding described in my last year's report great advantage has been gained in this already, and still better results are hoped for by still other improvements. Let me clearly indicate how progress in working sensitiveness may be consistent with a standstill in computed sensitiveness. The spot of light reflected from the mirror of the galvanometer needle, which should be quiet when no current is being observed, is always making slight excursions upon the scale, and these fluctuations prevent readings of current deflections to be made of less than a certain minimum amplitude, for they then become indistinguishable among the accidental deflections just mentioned. Let us now suppose that the average of accidental deflections should be reduced by better elimination of ground tremors and magnetic fluctuations from a millimeter to a tenth of a millimeter on the scale, then it is apparent that ten times the working sensitiveness is attained. But let us suppose that further improvement in these respects is found possible. It is hardly practicable to read the position of an ordinary spot of light more accurately than to the nearest tenth millimeter, so that little progress would directly result, but the time of swing of the needle might be profitably increased. Then, however, the effect of air damping would soon become so prejudicial as to stop advance.

We are now in position to state generally the methods employed and the results attained and hoped for here in this matter of increasing the working sensitiveness. The aim of all efforts is to make it possible to read deflections to a tenth of a millimeter on a scale at 3 meters with an actual time of single swing of ten seconds.

In the first place it has been sought to reduce the mechanical tremors of the galvanometer due to the city traffic; and for this purpose the elaborate pier and suspension system described in my last year's report was constructed. In the second place it has been attempted to reduce the prejudicial effects of these and other mechanical disturbing factors which still remain to jar the needle itself. To fully understand what has been planned for this purpose it should be stated that in addition to such mechanical tremors as have already been referred to, it has been found that the sound waves sent out from concussions of various kinds are able to seriously affect the steadiness of the needle. These sound waves can travel into the galvanometer case to jar the needle despite any system of support, and the only way to avoid them is to exhaust the air in the galvanometer, so that our new cases are of air-tight construction. The exhaustion of the air, in addition to preventing disturbance by sound waves, also *makes the sensitiveness nearly proportional to the square of time of swing of the needle*, so that it is no longer so unjust to use a ten-second time of single swing as the basis of comparison. But in addition to securing exhaustion of the air as a means of reducing mechanical tremors, another device has been found. The experimental and theoretical investigations of needle systems above alluded to have indicated a method of construction by means of which the *weight of the needle system can be largely increased without diminishing the com-*

*puted sensitiveness*, so that in this way the mechanical disturbances of sound and ground tremors which reach the galvanometer case, being compelled to influence a larger mass, will produce a less prejudicial effect upon the needle.

It has also been sought to reduce magnetic disturbances of the needle by the system of magnetic shielding described in my last year's report.

The application of these several devices has as yet proceeded only so far as is described in what follows: Several different systems of only 0.0019 gram weight have been tried in the galvanometer with the arrangements of support and shielding already described, but not with the air exhausted, and it has been found that up to times of single swing of two seconds the average accidental deflections on a scale at 3 meters do not exceed 0.1 millimeter, and the time of swing has actually been raised to ten seconds without excessive disturbances. The effectiveness of exhaustion of the air to make the sensitiveness proportional to the square of the time of swing has been studied, and these studies though not complete indicate that for air pressures of less than 1 millimeter of mercury this relation will be approximately followed.

A "heavy" needle system of 0.015 gram weight is in process of construction, whose computed sensitiveness, it is believed, will equal or slightly exceed that of the light systems already tried, while its steadiness will be much greater.

The most sensitive "light" needle system used gave at 1.5 seconds' single swing in atmospheric pressure a deflection of 1 millimeter on a scale at 1 meter in a galvanometer of 1.4 ohms resistance with a current of  $\frac{4}{100000000}$  ampères. The damping was then so excessive that the second swing was but  $\frac{1}{10}$  the magnitude of the first. If the hopes now reasonably entertained are realized the "heavy" needle can be effectively used at ten seconds' single swing in vacuum, with a scale at 3 meters, and a current of  $\frac{2}{100000000000}$  ampères will in actual practice give a deflection of 1 millimeter, and it is possible that a current of  $\frac{2}{1000000000000}$  ampères can be detected. Such a working sensitiveness as may thus be expected would exceed that employed in taking the holographs of 1898 by 5,000 fold, taking into account the ratio of the galvanometer resistance employed. The gain of working sensitiveness now actually attained in preliminary experiments is no less than a hundredfold. If the fiftyfold further gain hoped for is actually accomplished the field of research thus opened is enormous, so that I regard these improvements in the galvanometer as now the first consideration. It is greatly to be regretted, however, that owing to the unfortunate situation of the observatory in the midst of city disturbances the difficulties to be overcome are so large. In this connection, I venture to express the hope that the change of site of the observatory contemplated in your former reports may some time be accomplished.

*Personal equation apparatus.*—A portion of the time of the Junior Assistant has been employed in the testing of an apparatus of your own design to eliminate personal equation in time observations. These experiments are not yet completed.

*Absorption of the solar atmosphere.*—An investigation of the absorption of the solar radiation in the sun's atmosphere has been begun. A large solar image is formed, and holographs are made at points near the center and

edge of the sun, respectively. Preliminary experiments indicate an absorption progressively increasing toward the shorter wave lengths, so that curves taken with equal slit widths, while of nearly equal height at about  $2\mu$ , would exhibit nearly twice as much energy from the sun's center as from near the limb in the visible portion of the spectrum. So far as is yet determined there is no certainly discernible selective absorption for different narrow bands besides the gradual alteration of absorption just alluded to, but the experiments are as yet inconclusive as regards this point.

(3) *Eclipse expedition to Sumatra.*—It will be recalled that the observations of last year's eclipse by the Smithsonian expedition raised interesting questions as to the existence of intramercurial planets and as to the nature of the coronal radiations. So far did the interest in these problems extend that it was thought worth while to send an expedition from the Astrophysical Observatory to Sumatra to observe the total eclipse of May 18, 1901, and to repeat and extend the bolometric observations on the coronal radiation and the photographic observations for possible intramercurial planets. This expedition left Washington February 5, 1901; reached Padang, Sumatra, April 4; occupied the station selected (at Solok), April 11; and left Sumatra May 28. The personnel consisted of C. G. Abbot, Aid Acting in Charge, and P. A. Draper, temporary assistant. Apparatus weighing about 4,000 pounds was taken, including the 8-inch equatorial telescope mounting with celostat. Through the good offices of the War Department the voyages from San Francisco to Manila and the return were made upon army transports, while the expedition was conveyed from Manila to Padang and return upon the United States naval vessel *Gen. Alava*, which also conveyed the expedition from the United States Naval Observatory. It is a pleasure to remember the hospitality and friendliness of the officers of this vessel toward us. Within Sumatra the expedition was given free transportation upon the government railway, and indeed it would be hard to acknowledge sufficiently the assistance and courtesy received at the hands of the Dutch. I wish especially, however, to make mention of the great kindness and helpfulness of the United States consular agent at Padang, Mr. Cornelius G. Veth, who spared neither time nor expense in our behalf. The most cordial relations existed between the Smithsonian expedition and that of the United States Naval Observatory, such mutual assistance as could be afforded being freely interchanged.

Solok, Sumatra, the point selected for the observations, is a fair-sized town of mostly native inhabitants, but the seat of a Dutch residency. We found quarters in a small hotel, and an abandoned fort near the hotel was placed at our disposal for the observing station. This fort was shared with the larger party of the Naval Observatory, and its large rooms and inclosing walls, together with the sufficiently large level inclosure, made it an ideal station. Several years' meteorological observations having especial reference to the eclipse had indicated that Solok had at least as good chance of fair weather as any place in the island, and as the day of the eclipse approached we found from our own observations through the month of May that the chances for a fair sky around the sun at the hour of the eclipse were fully two to one. So far were these chances superior to those of Fort de Kock, a minor station near the edge of the shadow, occupied by





BCLOMETRIC APPARATUS OF SMITHSONIAN SOLAR ECLIPSE EXPEDITION TO SUMATRA.



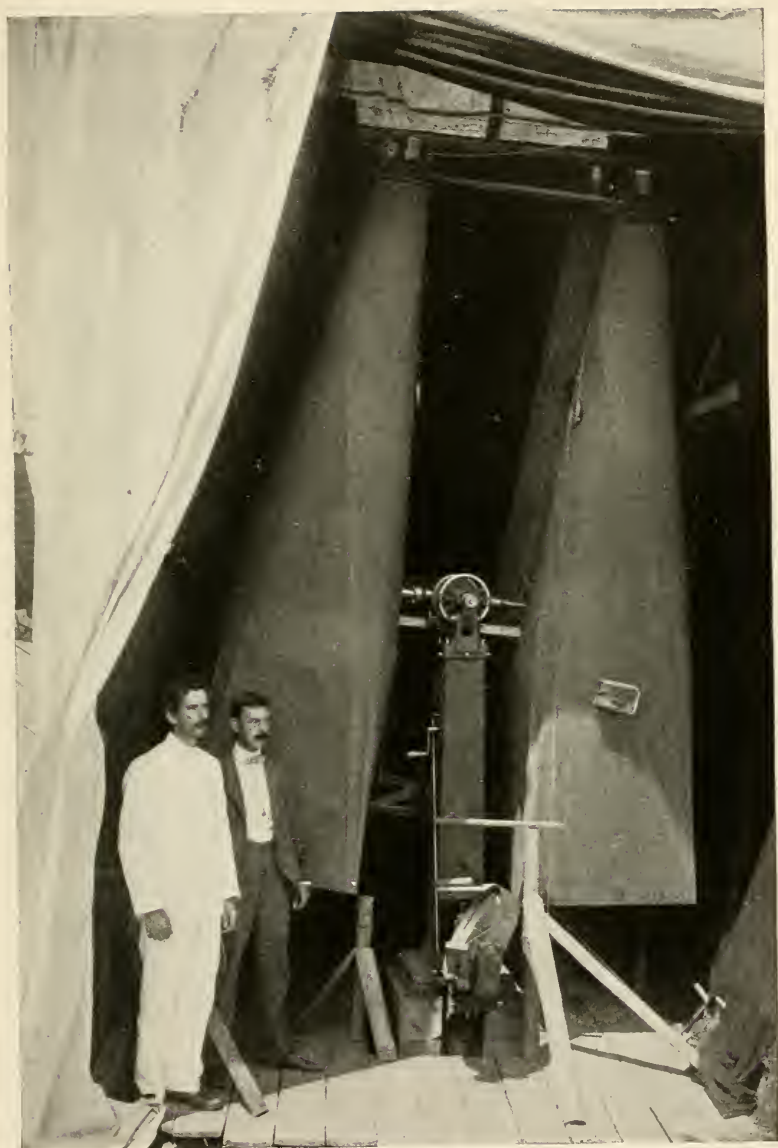

THE INTRA-MERCURIAL PLANET APPARATUS OF THE SMITHSONIAN INSTITUTION.





CAMP OF THE SMITHSONIAN SOLAR ECLIPSE EXPEDITION AT SOLOK, SUMATRA.







GROUP OF NATIVES, SOLOK, SUMATRA.



the Naval Observatory expedition, that the greatest depression prevailed in the messages received from that station prior to the eclipse. All was in readiness before the day of the eclipse, and very numerous rehearsals with both the bolometric and photographic apparatus had been held, and we felt that our arrangements were such that excellent results ought to be secured.

The day before the eclipse was rainy, but the morning of May 18 was clear, so that the prospects appeared of the brightest up to 9 or 10 o'clock. But about the time of the first contact clouds began to form, and when the eclipse became total, at about twenty minutes after noon, the whole sky, excepting a perfectly clear belt around the horizon, was overcast with a sort of checkerwork of clouds, so thick that the corona could barely be distinguished. During the latter part of totality the very position of the sun was doubtful. I realized that observations were useless, and I remained in the tent of the intramercorial-planet instrument throughout the totality without attempting bolometric work. Merely to have something to show to prove that the expedition had observed an eclipse, the programme for the intramercorial-planet apparatus was carried through, and I later developed the plates taken. Those exposed in the first half of totality showed the corona faintly, extending out possibly a quarter or half a diameter, and showed the planets Mercury and Venus. Nothing else could be distinguished, not even the first-magnitude star Aldebaran. The plates exposed during the last half showed even less, as the clouds were then thicker.

After totality the sky gradually cleared, and we had a fine afternoon and the clearest (and, indeed, almost the only) clear night there had been for weeks. The despised station at Fort de Kock had a perfect day throughout, and was the only station occupied by an eclipse expedition of which this was true. The meteorological conditions of Sumatra are not such as to encourage astronomical observation there.

I was much surprised at the amount of general illumination still remaining in the middle of totality. Some rainy days are equally as dark as it then was at Solok, although the totality lasted six minutes and the shadow was about 150 miles wide. The general illumination may have come from outside the shadow path by reflection and diffusion of the clouds, but yet there was, as has been said, a perfectly clear band of sky around the horizon, and hence far within the shadow.

The accompanying plates illustrate some of the scenes of this wonderfully interesting though woefully disappointing expedition.

In concluding this report I wish particularly to commend the ability and industry displayed by the Junior Assistant, Mr. F. E. Fowle, in carrying on the work of the Observatory during my absence, especially as regards bolometric work, which he did largely unassisted, and when the best part of the equipment was gone on the eclipse expedition.

Respectfully submitted.

C. G. ABBOT,

*Aid Acting in Charge Astrophysical Observatory.*

MR. S. P. LANGLEY,

*Secretary, Smithsonian Institution.*

APPENDIX VI.

REPORT OF THE LIBRARIAN FOR THE YEAR ENDING JUNE 30, 1901.

SIR: I have the honor to present herewith the report of the operations of the library of the Smithsonian Institution for the fiscal year ending June 30, 1901.

The most considerable portion of office work is that connected with the Smithsonian deposit in the Library of Congress.

The following table shows the number of volumes, parts of volumes, pamphlets, and charts recorded in the accession books of the Smithsonian deposit, Library of Congress, during the fiscal year ending June 30, 1901:

	Quarto or larger.	Octavo or smaller.	Total.
Volumes.....	518	1,413	1,931
Parts of volumes.....	14,695	6,673	21,368
Pamphlets.....	510	3,553	4,063
Charts.....			772
Total.....			28,134

The accession numbers run from 431972 to 438892.

In ever-increasing volume the operations of the library, like those of the International Exchanges, look to the strengthening of the Library of Congress. All books, pamphlets, charts, and completed volumes of periodicals are accessioned and recorded on cards as a permanent record file, which both serves as a ledger account with learned societies and establishments and as a catalogue of the Smithsonian deposit. The greater part of these publications are then sent to the Library of Congress, amounting during the past year to 192 boxes, 7 bags, and 30 packages, which are estimated to have contained the equivalent of 9,000 octavo volumes, this being a sending to the Library of Congress independent of that forwarded by the International Exchanges.

The additions to the libraries of the Secretary, the Office, and the Astrophysical Observatory number 374 volumes, pamphlets, and charts, and 2,058 parts of volumes, making a total of 2,432, and a grand total of 30,566. On the card catalogue of serial publications about 30,000 entries were made, of which 300 required new title cards.

The following universities have sent inaugural dissertations and academic publications: Albany, New York; Ann Arbor, Michigan; Baltimore, Maryland; Basel; Berlin; Bonn; Breslau; Czernowitz; Erlangen; Giesen; Freiburg; Greifswald; Halle a. S.; Heidelberg; Helsingfors; Ithaca, New

York; Jena; Kiel; Leipzig; Liege; Louvain; Lund; Marburg; Philadelphia, Pennsylvania; Rostock; Strasburg; Toulouse; Tubingen; Utrecht; Wurzburg; and Zurich.

A small but valuable collection is gradually being formed at the National Zoological Park, and two sectional libraries are maintained in the Institution in addition to those already alluded to, Aërodromics and Law Reference.

The circulating library established in 1898 for the employees of the Institution has continued to be used, to the pleasure and profit of the staff, and now contains about 1,280 volumes. During the year 2,515 volumes were borrowed by 105 persons. The rooms occupied by this small collection have been rendered more attractive.

In continuance of the policy of increasing the library by exchange and filling in incomplete sets, 919 letters were written for new exchanges and for completing series already in the library; 293 new periodicals were added to the list; 460 defective series were either completed or partly completed, according to the publishers' ability to supply the numbers requested. About 1,500 letters were received, which are filed in jackets on which a synopsis of the letters is given. A card catalogue of the correspondence is kept for reference. Orders are issued for the Smithsonian publications sent in exchange for the publications received; when single numbers are reported as missing postal cards are forwarded requesting that they be supplied; corresponding postal cards are sent as acknowledgments of receipts; about 200 were asked for and 150 supplied.

Lists and cards have been received from the Library of Congress since November, 1900, indicating the volumes which are needed to complete the sets in the Smithsonian deposit in the Library. These lists and cards are copied and kept permanently, while the originals are returned with notes stating what action has been taken.

The items which have been acted on show a very satisfactory result; the books in these cases which are received in compliance with requests are transmitted directly to the office of the Smithsonian deposit at the Library of Congress, marked "To complete Smithsonian sets."

The great activity of the large force at the Library of Congress in the various departments that have directly to do with the Smithsonian deposit has kept the Library force here exceedingly busy. Very great good is resulting from this activity, but much better results could be had if additional assistance were at my disposal, specifically for attending to the matters of mutual interest to the Library of Congress and the Institution.

Numerous transfers have been made from the Smithsonian deposit to the main collections of the Library and vice versa in the interest of completion of sets under a single ownership, such changes being made on the general principle that the Institution's collection shall consist primarily of periodicals and transactions of learned societies, whilst the Library of Congress should possess as complete files as possible of all publications issued by Government, whether Federal, State, or municipal, both domestic and foreign.

The third conference on the International Catalogue of Scientific Literature reached the conclusion that the Catalogue would be undertaken if

300 complete sets were subscribed for, and the Institution was informed in August, 1900, that the quota for the United States would be 45. A circular was immediately sent to the various colleges and libraries in this country, and in spite of the fact that it was the summer season, subscription to 45 sets was received by the middle of September, which number has since been increased to the equivalent of 66 sets, demonstrating the great interest had in this country in the undertaking. The preparation of a list of periodicals to be indexed has been taken in hand and indexing actually begun, two assistants being temporarily assigned for this purpose.

The accessions to the National Museum Library numbered a total of 12,267 books, pamphlets, and periodicals, of which 4,942 were a portion of the Smithsonian deposit; 25,141 books were borrowed. The efficiency of the Library has been materially added to by the institution by the Library of Congress of means of transferring books, etc., twice each day, thus enabling the Institution to receive and return books at a very short notice. The number of periodicals entered was 8,986, and 4,811 cards were added to the authors' catalogue of the Museum Library, which now contains 27 sections. Its operations will be more fully described in the report to the Assistant Secretary.

Respectfully submitted.

CYRUS ADLER, *Librarian.*

MR. S. P. LANGLEY,  
*Secretary, Smithsonian Institution.*

## APPENDIX VII.

### REPORT OF THE EDITOR FOR THE YEAR ENDING JUNE 30, 1901.

SIR: I have the honor to submit the following report on the publications of the Smithsonian Institution and its bureaus during the year ending June 30, 1901:

#### I. SMITHSONIAN CONTRIBUTIONS TO KNOWLEDGE.

A memoir on experiments with ionized air, by Dr. Carl Barus, has been sent to the printer, but was not completed at the close of the fiscal year.

#### II. MISCELLANEOUS COLLECTIONS.

1253. A Select Bibliography of Chemistry, 1492-1897. By Henry Carrington Bolton. Section VII, Academic Dissertations. Washington: Published by the Smithsonian Institution, 1901. Octavo. pp. vi + 534.

1258. On the Cheapest Form of Light. By S. P. Langley and F. W. Very. Washington: Published by the Smithsonian Institution, 1901. Octavo. pp. 20, with 3 plates.

1259. List of Observatories. Washington: Published by the Smithsonian Institution, 1901. Octavo. pp. 27. (Distributed as proof sheets, for revision.)

1305, 1306. The Smithsonian Institution. Documents relative to its origin and history. 1835-1899. Compiled and edited by William Jones Rhees. In two volumes. Washington: Government Printing Office, 1901. Octavo.

Vol. I, 1835 to 1887. Pages 1-LIII, 1-1044.

Vol. II, 1887 to 1899. Pages 1045-1983.

This work forms Volumes XLII and XLIII of Smithsonian Miscellaneous Collections. In his preface Mr. Rhees thus describes the object and contents of the volumes:

The present volume is undertaken in continuation of a volume bearing the title *The Smithsonian Institution: Documents Relative to its Origin and History*, prepared by the editor of the present volume, which, besides other matters, gives the legislative history of the Smithsonian Institution to 1877. Prefixed to this will be found a selection of the documents which passed between the United States and the attorneys in England antecedent to the actual reception of the bequest of James Smithson, a British subject, who gave his fortune to the United States of America "to found at Washington, under the name of the Smithsonian Institution, an establishment for the increase and diffusion of knowledge among men."

This fact was communicated through the United States legation at London to the Secretary of State, and was made the subject of a special message to Congress by President Jackson on December 17, 1835. The message was referred to committees, and it was at last agreed that, although there was some doubt as to the propriety of accepting it, the bequest should be obtained, if possible, and the Hon. Richard Rush was sent to England in July, 1836, as a special agent of the United States, with power of attorney from the

President to prosecute the claim in the chancery court. The fund was brought to this country in 1838, and after eight years of debate, including consultation with all the leading educators of the United States at that time, a law was finally framed on August 10, 1846, "to establish the Smithsonian Institution for the increase and diffusion of knowledge among men." Under this act, with a few amendments, the operations of the Institution have been carried on to the present time, and a detailed account of the legislation by Congress, as well as of proposed action, from 1835 to March 3, 1899, is given in this work. The legislation fully accomplished is shown by acts and joint resolutions, followed in all cases by references to the volumes and pages of the Statutes at Large from which they were quoted.

Concurrent resolutions of the Senate and House and separate resolutions of either branch of Congress are referred to by the dates of action.

An account is also given of action or discussion relative to objects intrusted by Congress to the care of the Institution, and of some of the operations of the Government with which it has had direct or incidental connection.

The proceedings of each Congress are given successively, the first volume containing those of the Twenty-fourth Congress to the Forty-ninth and the second volume those of the Fiftieth to the Fifty-fifth Congress.

Under each Congress the subjects are arranged according to the date of their introduction, all action in that Congress on each subject following in chronological order, excepting that estimates and appropriations are placed at the end of each subject.

In the preparation of this work an examination was made of every page of the Congressional Globe and Congressional Record, of the journals of the Senate and House, the Statutes at Large, the Congressional documents and reports from 1835 to 1899, together with other printed and manuscript material in the Institution and elsewhere; and the table of contents and index are as comprehensive and minute as possible, the latter being alphabetical, analytical, and chronological.

The formal details of legislation in most cases are abbreviated, and the quotations from the statutes, giving dates and amounts appropriated, are always given in figures, and not in words.

### III. SMITHSONIAN ANNUAL REPORTS.

1177. Annual Report of the Board of Regents of the Smithsonian Institution, showing the operations, expenditures, and condition of the Institution for the year ending June 30, 1897. Report of the U. S. National Museum, Part II. [A memorial of George Brown Goode.] Washington: Government Printing Office, 1901. Octavo. xii + 515 pages, with 109 portraits.

1218. Annual Report of the Board of Regents of the Smithsonian Institution, showing the operations, expenditures, and condition of the Institution for the year ending June 30, 1898. Report of the U. S. National Museum. Washington: Government Printing Office, 1900. Octavo. xvii + 1,294 pages, with 36 plates and 347 text figures.

1252. Annual Report of the Board of Regents of the Smithsonian Institution, showing the operations, expenditures, and condition of the Institution for the year ending June 30, 1899. Washington: Government Printing Office, 1901. Octavo. lxiii + 672 pages, with 82 plates.

1254. Annual Report of the Board of Regents of the Smithsonian Institution, showing the operations, expenditures, and condition of the Institution for the year ending June 30, 1899. Report of the U. S. National Museum. Washington: Government Printing Office, 1901. xv + 598 pages, with 98 plates and 38 text figures.

1260. Annual Report of the Board of Regents of the Smithsonian Institution, showing the operations, expenditures, and condition of the Institution for the year ending June 30, 1900. Washington: Government Printing Office, 1901. Octavo. lv + 759 pages, with 108 plates.

## IV. SEPARATES FROM SMITHSONIAN REPORTS.

1221. Journal of Proceedings of the Board of Regents of the Smithsonian Institution, report of executive committee, acts and resolutions of Congress. From the Smithsonian Report for 1899, pages XL-LXIII. Washington: Government Printing Office, 1901. Octavo.

1222. The Wave Theory of Light. By A. Cornu. From the Smithsonian Report for 1899, pages 93-105. Washington: Government Printing Office, 1901. Octavo.

1223. The Motion of a Perfect Liquid. By Prof. H. S. Hele-Shaw. From the Smithsonian Report for 1899, pages 107-118, with Plates I-IV. Washington: Government Printing Office, 1901. Octavo.

1224. The Field of Experimental Research. By Elihu Thomson. From the Smithsonian Report for 1899, pages 119-130. Washington: Government Printing Office, 1901. Octavo.

1225. Liquid Hydrogen. By Professor Dewar. From the Smithsonian Report for 1899, pages 131-142, with Plates I, II. Washington: Government Printing Office, 1901. Octavo.

1226. Some of the Latest Achievements of Science. By Sir William Crookes. From the Smithsonian Report for 1899, pages 143-153. Washington: Government Printing Office, 1901. Octavo.

1227. An Experimental Study of Radio-Active Substances. By Henry Carrington Bolton. From the Smithsonian Report for 1899, pages 155-162. Washington: Government Printing Office, 1901. Octavo.

1228. The Growth of Science in the Nineteenth Century. By Sir Michael Foster. From the Smithsonian Report for 1899, pages 163-183. Washington: Government Printing Office, 1901. Octavo.

1229. Sir William Crookes on Psychical Research. From the Smithsonian Report for 1899, pages 185-205. Washington: Government Printing Office, 1901. Octavo.

1230. Survey of that Part of the Range of Nature's Operations which Man is Competent to Study. By G. Johnstone Stoney. From the Smithsonian Report for 1899, pages 207-222, with figures. Washington: Government Printing Office, 1901. Octavo.

1231. On Lord Kelvin's Address on the Age of the Earth as an Abode Fitted for Life. By Prof. T. C. Chamberlain. From the Smithsonian Report for 1899, pages 223-246. Washington: Government Printing Office, 1901. Octavo.

1232. An Estimate of the Geological Age of the Earth. By J. Joly. From the Smithsonian Report for 1899, pages 247-288. Washington: Government Printing Office, 1901. Octavo.

1233. The Petrified Forests of Arizona. By Lester F. Ward. From the Smithsonian Report for 1899, pages 289-307, with Plates I-III. Washington: Government Printing Office, 1901. Octavo.

1234. Present Condition of the Floor of the Ocean: Evolution of the Continental and Oceanic Areas. By Sir John Murray. From the Smithsonian Report for 1899, pages 309-328. Washington: Government Printing Office, 1901. Octavo.

1235. Relation of Motion in Animals and Plants to the Electrical Phe-

nomena which are Associated with It. By J. Burdon-Sanderson. From the Smithsonian Report for 1899, pages 329-351, with Plates I-IV. Washington: Government Printing Office, 1901. Octavo.

1236. The Truth About the Mammoth. By Frederic A. Lucas. From the Smithsonian Report for 1899, pages 353-359, with Plates I-IV. Washington: Government Printing Office, 1901. Octavo.

1237. Mammoth Ivory. By R. Lydekker. From the Smithsonian Report for 1899, pages 361-366. Washington: Government Printing Office, 1901. Octavo.

1238. On the Sense of Smell in Birds. By M. Xavièr Raspail. From the Smithsonian Report for 1899, pages 367-373. Washington: Government Printing Office, 1901. Octavo.

1239. Have Fishes Memory? By L. Edinger. From the Smithsonian Report for 1899, pages 375-394. Washington: Government Printing Office, 1901. Octavo.

1240. Scientific Thought in the Nineteenth Century. By William North Rice. From the Smithsonian Report for 1899, pages 395-402. Washington: Government Printing Office, 1901. Octavo.

1241. The Garden and Its Development. By Paul Falkenberg. From the Smithsonian Report for 1899, pages 403-418. Washington: Government Printing Office, 1901. Octavo.

1242. Review of the Evidence Relating to Auriferous Gravel Man in California. By William H. Holmes. From the Smithsonian Report for 1899, pages 419-472, Plates I-XVI. Washington: Government Printing Office, 1901. Octavo.

1243. A Problem in American Anthropology. By Frederic Ward Putnam. From the Smithsonian Report for 1899, pages 473-486. Washington: Government Printing Office, 1901. Octavo.

1244. On Sea Charts Formerly Used in the Marshall Islands, with Notices on the Navigation of these Islanders in General. By Captain Winkler, of the German Navy. From the Smithsonian Report for 1899, pages 487-508, with Plates I-XV. Washington: Government Printing Office, 1901. Octavo.

1245. The Peopling of the Philippines. By Rudolf Virchow. From the Smithsonian Report for 1899, pages 509-526, with Plates I-III. Washington: Government Printing Office, 1901. Octavo.

1246. List of the Native Tribes of the Philippines and of the Languages Spoken by Them. By Prof. Ferdinand Blumentritt. From the Smithsonian Report for 1899, pages 527-547, with Plates I-X. Washington: Government Printing Office, 1901. Octavo.

1247. The Sculptures of Santa Lucia Cozumhualpa, Guatemala, in the Hamburg Ethnological Museum. By Herman Strebel. From the Smithsonian Report for 1899, pages 549-561, with Plates I-XI. Washington: Government Printing Office, 1901. Octavo.

1248. Count Von Zeppelin's Dirigible Air Ship. From the Smithsonian Report for 1899, pages 563-565, with Plates I-II. Washington: Government Printing Office, 1901. Octavo.

1249. The Progress in Steam Navigation. By Sir William H. White, of the British Navy. From the Smithsonian Report for 1899, pages 567-590. Washington: Government Printing Office, 1901. Octavo.



1250. A Century's Progress of the Steam Engine. By Dr. R. H. Thurston. From the Smithsonian Report for 1899, pages 591-603. Washington: Government Printing Office, 1901. Octavo.

1251. Bunsen Memorial Lecture. By Sir Henry Roscoe. From the Smithsonian Report for 1899, pages 605-644, with Plates I-VII. Washington: Government Printing Office, 1901. Octavo.

1255. Report of S. P. Langley, Secretary of the Smithsonian Institution, for the Year ending June 30, 1900, pages 1-117, with Plates I-XVIII. Washington: Government Printing Office, 1900. Octavo.

1261. Journal of Proceedings of the Board of Regents of the Smithsonian Institution, Report of Executive Committee, Acts and Resolutions of Congress. From the Smithsonian Report for 1900, pages xi-LXV. Octavo pamphlet.

1262. Progress in Astronomy during the Nineteenth Century. By Sir Norman Lockyer. From the Smithsonian Report for 1900, pages 123-147. Washington: Government Printing Office, 1901. Octavo.

1263. A Preliminary Account of the Solar Eclipse of May 28, 1900, as observed by the Smithsonian Expedition. By S. P. Langley. From the Smithsonian Report for 1900, pages 149-156, with Plates I-IV. Washington: Government Printing Office, 1901. Octavo.

1264. Notes on Mars. By Sir Robert Ball and others. From the Smithsonian Report for 1900, pages 157-172. Washington: Government Printing Office, 1901. Octavo.

1265. On Solar Changes of Temperature and Variations in Rainfall in the Region Surrounding the Indian Ocean. By Sir Norman Lockyer. From the Smithsonian Report for 1900, pages 173-184, with Plates I, II. Washington: Government Printing Office, 1901. Octavo.

1266. The Pekin Observatory. From the Smithsonian Report for 1900, pages 185-186, with Plates I-IV. Washington: Government Printing Office, 1901. Octavo.

1267. The Progress of Aeronautics. By M. Janssen. From the Smithsonian Report for 1900, pages 187-193. Washington: Government Printing Office, 1901. Octavo.

1268. Lord Rayleigh on "Flight." From the Smithsonian Report for 1900, pages 195-196. Washington: Government Printing Office, 1901. Octavo.

1269. The Langley Aërodrome. From the Smithsonian Report for 1900, pages 197-216, with Plates I-VI. Washington: Government Printing Office, 1901. Octavo.

1270. The Zeppelin Air Ship. By Thomas E. Curtis. [James Walter Smith.] From the Smithsonian Report for 1900, pages 217-222, with Plates I-VI. Washington: Government Printing Office, 1901. Octavo.

1271. The Use of Kites to Obtain Meteorological Observations. By A. Lawrence Rotch. From the Smithsonian Report for 1900, pages 223-231, with Plates I-III. Washington: Government Printing Office, 1901. Octavo.

1272. Progress in Chemistry in the Nineteenth Century. By Prof. William Ramsay. From the Smithsonian Report for 1900, pages 233-257. Washington: Government Printing Office, 1901. Octavo.

1273. Liquid Hydrogen. By Prof. James Dewar. From the Smithsonian Report for 1900, pages 259-264, with Plates I-IV. Washington: Government Printing Office, 1901. Octavo.

1274. A Century of Geology. By Prof. Joseph Le Conte. From the Smithsonian Report for 1900, pages 265-287. Washington: Government Printing Office, 1901. Octavo.

1275. Evolutional Geology. By Prof. W. J. Sollas. From the Smithsonian Report for 1900, pages 289-314, with Plate I. Washington: Government Printing Office, 1901. Octavo.

1276. Progress in Physics in the Nineteenth Century. By Prof. T. C. Mendenhall. From the Smithsonian Report for 1900, pages 315-331. Washington: Government Printing Office, 1901. Octavo.

1277. Electricity during the Nineteenth Century. By Prof. Elihu Thomson. From the Smithsonian Report for 1900, pages 333-358. Washington: Government Printing Office, 1901. Octavo.

1278. The Photography of Sound Waves and the Demonstration of the Evolutions of Reflected Wave Fronts with the Cinematograph. By R. W. Wood. From the Smithsonian Report for 1900, pages 359-369, with Plates I-VI. Washington: Government Printing Office, 1901. Octavo.

1279. Unsuspected Radiations. By Prince Kropotkin. From the Smithsonian Report for 1900, pages 371-385. Washington: Government Printing Office, 1901. Octavo.

1280. Incandescent Mantles. By Vivian B. Lewes. From the Smithsonian Report for 1900, pages 387-401, with 2 text figures. Washington: Government Printing Office, 1901. Octavo.

1281. The Imperial Physico-Technical Institution in Charlottenburg. By Henry S. Crahart. From the Smithsonian Report for 1900, pages 403-415, with Plates I-IV. Washington: Government Printing Office, 1901. Octavo.

1282. The Geographic Conquests of the Nineteenth Century. By Gilbert H. Grosvenor. From the Smithsonian Report for 1900, pages 417-430, with Plate I, and 12 text figures. Washington: Government Printing Office, 1901. Octavo.

1283. Through Africa From the Cape to Cairo. By Ewart S. Grogan. From the Smithsonian Report for 1900, pages 431-448, with Plates I-IV. Washington: Government Printing Office, 1901. Octavo.

1284. The "Yermak" Ice Breaker. By Vice-Admiral Makaroff, of the Russian Imperial Navy. From the Smithsonian Report for 1900, pages 449-459, with Plates I-III. Washington: Government Printing Office, 1901. Octavo.

1285. The Growth of Biology in the Nineteenth Century. By Oscar Hertwig. From the Smithsonian Report for 1900, pages 461-478. Washington: Government Printing Office, 1901. Octavo.

1286. The Restoration of Extinct Animals. By Frederic A. Lucas. From the Smithsonian Report for 1900, pages 479-492, with Plates I-VIII, and 2 text figures. Washington: Government Printing Office, 1901. Octavo.

1287. Life in the Ocean. By Karl Brandt. From the Smithsonian Report for 1900, pages 493-506. Washington: Government Printing Office, 1901. Octavo.

1288. Nature Pictures. By A. Radclyffe Dugmore. From the Smithsonian Report for 1900, pages 507-515, with Plates I-XVII. Washington: Government Printing Office, 1901. Octavo.

1289. The Outlaw: a Character Study of a Beaver who was cast out by his Companions. By A. Radclyffe Dugmore. From the Smithsonian Report for 1900, pages 517-522, with Plates I-VI. Washington: Government Printing Office, 1901. Octavo.

1290. A Notable Advance in Color Photography. From the Smithsonian Report for 1900, pages 523-526, with Plate I, and 5 text figures. Washington: Government Printing Office, 1901. Octavo.

1291. The Breeding of the Arctic Fox. By Henry de Varigny. From the Smithsonian Report for 1900, pages 527-533. Washington: Government Printing Office, 1901. Octavo.

1292. Discoveries in Mesopotamia. By Dr. Frederick Delitzsch. From the Smithsonian Report for 1900, pages 535-549, with Plates I-X. Washington: Government Printing Office, 1901. Octavo.

1293. On Ancient Desemers or Steelyards. By Herrman Sökeland. From the Smithsonian Report for 1900, pages 551-564, with 22 text figures. Washington: Government Printing Office, 1901. Octavo.

1294. Mutual Helpfulness between China and the United States. By his excellency Wu Ting-Fang. From the Smithsonian Report for 1900, pages 565-574. Washington: Government Printing Office, 1901. Octavo.

1295. Chinese Folklore and Some Western Analogies. By Frederick Wells Williams. From the Smithsonian Report for 1900, pages 575-600. Washington: Government Printing Office, 1901. Octavo.

1296. The Loot of the Imperial Summer Palace at Peking in 1860. By Count D'Hérison. From the Smithsonian Report for 1900, pages 601-635. Washington: Government Printing Office, 1901. Octavo.

1297. Progress of Medicine in the Nineteenth Century. By Dr. John S. Billings, U. S. A. From the Smithsonian Report for 1900, pages 637-644. Washington: Government Printing Office, 1901. Octavo.

1298. Malaria. By George M. Sternberg, M. D., U. S. A. From the Smithsonian Report for 1900, pages 645-656. Washington: Government Printing Office, 1901. Octavo.

1299. Transmission of Yellow Fever by Mosquitoes. By George M. Sternberg, M. D., U. S. A. From the Smithsonian Report for 1900, pages 657-673. Washington: Government Printing Office, 1901. Octavo.

1300. Psychical Research of the Century. By Andrew Lang. From the Smithsonian Report for 1900, pages 675-681. Washington: Government Printing Office, 1901. Octavo.

1301. The New Spectrum. By S. P. Langley. From the Smithsonian Report for 1900, pages 683-692, with colored plate. Washington: Government Printing Office, 1901. Octavo.

1302. The Century's Great Men in Science. By Charles S. Peirce. From the Smithsonian Report for 1900, pages 693-699. Washington: Government Printing Office, 1901. Octavo.

1303. The Lesson of the Life of Huxley. By William Keith Brooks. From the Smithsonian Report for 1900, pages 701-711. Washington: Government Printing Office, 1901. Octavo.

1304. *Reminiscences of Huxley.* By John Fiske. From the Smithsonian Report for 1900, pages 713-728. Washington: Government Printing Office, 1901. Octavo.

Report upon the condition and progress of the U. S. National Museum during the year ending June 30, 1898. By Charles D. Walcott, acting assistant secretary of the Smithsonian Institution in charge of the U. S. National Museum. From the Annual Report of the U. S. National Museum for 1898, pages 1-149. Octavo.

*The Crocodilians, Lizards, and Snakes of North America.* By Edward Drinker Cope, A. M., Ph. D. From the Annual Report of the U. S. National Museum for 1898, pages 153-1270, with 36 plates and 347 figs. Octavo.

Report upon the condition and progress of the U. S. National Museum during the year ending June 30, 1899. By Richard Rathbun, assistant secretary of the Smithsonian Institution. From the Annual Report of the U. S. National Museum for 1899, pages 1-152. Octavo.

Guide to the Study of the Collections in the Section of Applied Geology. The nonmetallic minerals. By George P. Merrill, curator Division of Physical and Chemical Geology and head curator of the Department. From the Annual Report of the U. S. National Museum for 1899, pages 155-483, with 30 plates and 13 figures. Octavo.

Report on the Department of Biology for the year 1898-99. By Frederick W. True, head curator. From the Annual Report of the U. S. National Museum for 1899, pages 25-35. Octavo.

Report on the Department of Anthropology for the year 1898-99. By William H. Holmes, head curator. From the Annual Report of the U. S. National Museum for 1899, pages 17-24. Octavo.

Report on the Department of Geology for the year 1898-99. By George P. Merrill, head curator. From the Annual Report of the U. S. National Museum for 1899, pages 37-49. Octavo.

*A Primitive Frame for Weaving Narrow Fabrics,* by Otis Tufton Mason, curator, Division of Ethnology. From the Annual Report of the United States National Museum for 1899, pages 487-510, with 9 plates and 19 figures. Octavo.

*An Early West Virginia Pottery,* by Walter Hough, assistant curator, Division of Ethnology. From the Annual Report of the United States National Museum for 1899, pages 511-521, with 18 plates. Octavo.

*Pointed Bark Canoes of the Kutenai and Amur,* by Otis T. Mason, curator, Division of Ethnology, with notes on the Kutenai by Meriden S. Hill. From the Annual Report of the United States National Museum for 1899, pages 523-537, with 5 plates and 6 figures. Octavo.

*Descriptive Catalogue of a Collection of Objects of Jewish Ceremonial Deposited in the United States National Museum* by Hadji Ephraim Benguiat, by Cyrus Adler, Ph. D., custodian, Section of Historic Religious Ceremonials, and I. M. Casanowicz, Ph. D., Aid, Division of Historical Archaeology. From the Annual Report of the United States National Museum for 1899, pages 539-561, with 36 plates. Octavo.

#### V. SPECIAL SMITHSONIAN PUBLICATIONS.

1256. *Publications of the Smithsonian Institution available for distribution,* March, 1901. Washington: March, 1901. Octavo, pp. 55.

## VI. PUBLICATIONS OF NATIONAL MUSEUM.

Special Bulletin. American Hydroids. Part I. The Plumulariæ, with thirty-four plates. By Charles Cleveland Nutting, professor of zoology, University of Iowa. Washington: Government Printing Office. 1900. Quarto. pp. 285, with Plates I-XXXIV.

Proceedings of the United States National Museum. Volume XXII. Published under the direction of the Smithsonian Institution. Washington: Government Printing Office. 1900. xii + 1075 pages, with 18 plates. Octavo.

Proc. 1203. A Hundred new Moths of the Family Noctuidæ. By John B. Smith. From the Proceedings of the United States National Museum, Vol. XXII, pages 413-495. Washington: Government Printing Office, 1900. Octavo.

Proc. 1204. A new Bird of Paradise. By Rolla P. Currie. From the Proceedings of the United States National Museum, Vol. XXII, pages 497-499, with Plate XVII. Washington: Government Printing Office, 1900. Octavo.

Proc. 1205. Synopsis of the Naiades, or Pearly Fresh-Water Mussels. By Charles Torrey Simpson. From the Proceedings of the United States National Museum, Vol. XXII, pages 501-1044, with Plate XVIII. Washington: Government Printing Office, 1900. Octavo.

Proc. 1206. Classification of the Ichnemon Flies, or the Superfamily Ichnemonoidea. By William H. Ashmead. From the Proceedings of the United States National Museum, Vol. XXIII, pages 1-220. Washington: Government Printing Office, 1900. Octavo.

Proc. 1207. A new Rhinoceros, *Trigonias osborni*, from the Miocene of South Dakota. By Frederic A. Lucas. From the Proceedings of the United States National Museum, Vol. XXIII, pages 221-223. Washington: Government Printing Office, 1900. Octavo.

Proc. 1208. New species of Moths of the Superfamily Tineina from Florida. By August Busch. From the Proceedings of the United States National Museum, Vol. XXIII, pages 225-254, with Plate I. Washington: Government Printing Office, 1900. Octavo.

Proc. 1209. Life Histories of Some North American Moths. By Harrison G. Dyar. From the Proceedings of the United States National Museum, Vol. XXIII, pages 255-284. Washington: Government Printing Office, 1900. Octavo.

Proc. 1210. Synopsis of the Family Tellinidæ and of the North American Species. By William Healey Dall. From the Proceedings of the United States National Museum, Vol. XXIII, pages 285-326, with Plates II-IV. Washington: Government Printing Office, 1900. Octavo.

Proc. 1211. The Pelvic Girdle of *Zenglodon*, *Basilosaurus cetooides* (Owen), with notes on other portions of the skeleton. By Frederic A. Lucas. From the Proceedings of the United States National Museum, Vol. XXIII, pages 327-331, with Plates V-VII. Washington: Government Printing Office, 1900. Octavo.

Proc. 1212. A new Fossil Cyprinoid, *Leuciscus turneri*, from the Miocene of Nevada. By Frederic A. Lucas. From the Proceedings of the

United States National Museum, Vol. XXIII, pages 333-334, with Plate VIII. Washington: Government Printing Office, 1900. Octavo.

Proc. 1213. A List of Fishes Collected in Japan by Keinosuke Otaki and by the U. S. S. *Albatross*, with descriptions of fourteen new species. By David Starr Jordan and John Otterbein Snyder. From the Proceedings of the United States National Museum, Vol. XXIII, page 335-380, with Plates IX-XX. Washington: Government Printing Office, 1900. Octavo.

Proc. 1214. Synopsis of the Family Carliidæ and of the North American species. By William Healey Dall. From the Proceedings of the United States National Museum, Vol. XXIII, pages 381-392. Washington: Government Printing Office, 1900. Octavo.

Proc. 1215. Revision of the Orthopteran Genus *Trimerotropis*. By Jerome McNeill. From the Proceedings of the United States National Museum, Vol. XXIII, pages 393-449, with Plate XXI. Washington: Government Printing Office, 1901. Octavo.

Proc. 1216. The Hermit Crabs of the *Pagurus bernhardus* type. By James E. Benedict. From the Proceedings of the United States National Museum, Vol. XXIII, pages 451-466. Washington: Government Printing Office, 1901. Octavo.

Proc. 1217. On a new species of Spiny-tailed Iguana from Utilia Island, Honduras. By Leonhard Stejneger. Pages 467, 468. Washington: Government Printing Office, 1901. Octavo.

Proc. 1218. New systematic name for the Yellow Boa of Jamaica. By Leonhard Stejneger. From the Proceedings of the United States National Museum, Vol. XXIII, pages 469-470. Octavo.

Proc. 1219. Diagnosis of a new species of Iguanoid Lizard from Green Cay, Bahama Islands. By Leonhard Stejneger. From the Proceedings of the United States National Museum, Vol. XXIII, pages 471, 472. Washington: Government Printing Office, 1901. Octavo.

Proc. 1220. On the Wheatears (*Saxicola*) occurring in North America. By Leonhard Stejneger. From the Proceedings of the United States National Museum, Vol. XXIII, pages 473-481. Washington: Government Printing Office, 1901. Octavo.

Proc. 1221. List of Fishes collected in the River Pei-Ho, at Tien-Tsin, China, by Noah Fields Drake, with descriptions of seven new species. By James Francis Abbott. From the Proceedings of the United States National Museum, Vol. XXIII, pages 483-491. Washington: Government Printing Office, 1901. Octavo.

Proc. 1222. Key to the Isopods of the Atlantic Coast of North America, with descriptions of new and little known species. By Harriet Richardson. From the Proceedings of the United States National Museum, Vol. XXIII, pages 493-579. Washington: Government Printing Office, 1901. Octavo.

Proc. 1223. Some Spiders and other Arachnida from Southern Arizona. By Nathan Banks. From the Proceedings of the United States National Museum, Vol. XXIII, pages 581-590, with Plate XXII. Washington: Government Printing Office, 1901. Octavo.

Proc. 1224. A new Dinosaur, *Stegosaurus marshi*, from the Lower Cretaceous of South Dakota. By Frederic A. Lucas. From the Proceedings

of the United States National Museum, Vol. XXIII, pages 591, 592, with Plates XXIII, XXIV. Washington: Government Printing Office 1901. Octavo.

Proc. 1225. New Diptera in the United States National Museum. By D. W. Coquillett. From the Proceedings of the United States National Museum, Vol. XXIII, pages 593-618. Washington: Government Printing Office. 1901. Octavo.

Proc. 1226. A List of the Ferns and Fern Allies of North America North of Mexico, with principal synonyms and distribution. By William R. Maxon. From the Proceedings of the United States National Museum, Vol. XXIII, pages 619-651. Washington: Government Printing Office. 1901. Octavo.

Proc. 1227. A Systematic Arrangement of the Families of the Diptera. By D. W. Coquillett. From the Proceedings of the United States National Museum, Vol. XXIII, pages 653-658. Washington: Government Printing Office. 1901. Octavo.

Proc. 1228. A Comparison of the Osteology of the Jerboas and Jumping Mice. By Marcus W. Lyon, jr. From the Proceedings of the United States National Museum, Vol. XXIII, pages 659-668; with Plates XXV-XXVII. Washington: Government Printing Office. 1901. Octavo.

Proc. 1229. Cambrian Brachiopoda: *Obolella*, subgenus *Glyptias*; *Bicia*; *Obollus*, subgenus *Westonia*; with descriptions of new species. By Charles D. Walcott. From the Proceedings of the United States National Museum, Vol. XXIII, pages 669-695. Washington: Government Printing Office. 1901. Octavo.

Proc. 1230. A Revision of certain species of Plants of the Genus *Antennaria*. By Elias Nelson. From the Proceedings of the United States National Museum, Vol. XXIII, pages 697-713. Washington: Government Printing Office. 1901. Octavo.

Proc. 1231. Description of a new species of Snake from Clarion Island, West Coast of Mexico. By Leonhard Stejneger. From the Proceedings of the United States National Museum, Vol. XXIII, pages 715-717. Washington: Government Printing Office. 1901. Octavo.

Proc. 1232. On the Relationships of the Lutianoid Fish, *Aphareus furcatus*. By David Starr Jordan and Edwin Chapin Starks. From the Proceedings of the United States National Museum, Vol. XXIII, pages 719-723, with Plates XXVIII, XXIX. Washington: Government Printing Office. 1901. Octavo.

Proc. 1233. A Review of the Lancelets, Hag-fishes, and Lampreys of Japan, with a description of two new species. By David Starr Jordan and John Otterbein Snyder. From the Proceedings of the United States National Museum. Vol. XXIII, pages 725-734, with Plate XXX. Washington: Government Printing Office. 1901. Octavo.

Proc. 1234. The proper names of *Bdellostoma* or *Heptatrema*. By Theodore Gill. From the Proceedings of the United States National Museum, Vol. XXIII, pages 735-738. Washington: Government Printing Office. 1901. Octavo.

## VII. PUBLICATIONS OF THE BUREAU OF AMERICAN ETHNOLOGY.

The first part of the Seventeenth Report and the first part of the Eighteenth Report were received from the Government Printing Office and distributed during the year.

Seventeenth Annual Report of the Bureau of American Ethnology to the Secretary of the Smithsonian Institution. 1895-96. By J. W. Powell, Director. In two parts. Part I. Washington: Government Printing Office. 1898. Imperial octavo. Pages i-xciii, 1-128, 129\*-344\*, 137-468, with 81 plates and 229 text figures.

Eighteenth Annual Report of the Bureau of American Ethnology to the Secretary of the Smithsonian Institution. 1896-97. By J. W. Powell, Director. In two parts. Part I. Washington: Government Printing Office. 1899. Imperial octavo. Pages i-lvii, 1-518, with 174 plates and 165 text figures.

## VIII. PUBLICATION OF AMERICAN HISTORICAL ASSOCIATION.

The Annual Report of the American Historical Association for the year 1900 was sent to the printer toward the close of the fiscal year, and most of it was in type before June 30. The report is in two volumes, with the following contents:

Report of Proceedings of Sixteenth Annual Meeting in Detroit and Ann Arbor, December 27-29, 1900, by A. Howard Clark, secretary—The New History, by Edward Eggleston, president—Concerning the Writing of History, by James Ford Rhodes—Plea for Military History, by Charles Francis Adams—Sectionalism and Representation in South Carolina, a Sociological Study, by William A. Schaper—Frontier Land Clubs, or Claim Associations, by Benjamin F. Shambaugh—Missouri Party Struggles in the Civil-War Period, by S. B. Harding—Military Government of Southern Territory, 1861-1865, by A. H. Carpenter—Marcus Whitman: A Discussion of Professor Bourne's Paper, by William I. Marshall—Lord Baltimore's Struggle with the Jesuits, 1634-1649, by Alfred Pearce Dennis—American Ecclesiology, by George James Bayles—Studies in the Colonial Period of England, 1672-1680: The Plantations, the Royal African Company, and the Slave Trade, by Edward D. Collins—Critical Work on the Latin Sources of the First Crusade, by Oliver J. Thatcher—The Turkish Capitulation, by James B. Angell—Stein's German Policy at the Congress of Vienna, by Ulysses G. Weatherly—The Considerations which induced Edward III to Assume the Title King of France, by Walter Irenæus Lowe—Fifth Annual Report of the Historical Manuscripts Commission—Titles of Books on English History, published in 1899; selected by W. Dawson Johnston—Report of the Public Archives Commission.

## IX. NATIONAL SOCIETY OF THE DAUGHTERS OF THE AMERICAN REVOLUTION.

The Third Report of the Society was received and submitted to Congress during the year and progress made toward its publication as a Senate Document.

Respectfully submitted.

A. HOWARD CLARK, *Editor.*

Mr. S. P. LANGLEY,  
*Secretary, Smithsonian Institution*



---

GENERAL APPENDIX

TO THE

SMITHSONIAN REPORT FOR 1901.

---



## ADVERTISEMENT.

---

The object of the GENERAL APPENDIX to the Annual Report of the Smithsonian Institution is to furnish brief accounts of scientific discovery in particular directions; reports of investigations made by collaborators of the Institution; and memoirs of a general character or on special topics that are of interest or value to the numerous correspondents of the Institution.

It has been a prominent object of the Board of Regents of the Smithsonian Institution, from a very early date, to enrich the annual report required of them by law with memoirs illustrating the more remarkable and important developments in physical and biological discovery, as well as showing the general character of the operations of the Institution; and this purpose has, during the greater part of its history, been carried out largely by the publication of such papers as would possess an interest to all attracted by scientific progress.

In 1880 the Secretary, induced in part by the discontinuance of an annual summary of progress which for thirty years previous had been issued by well-known private publishing firms, had prepared by competent collaborators a series of abstracts, showing concisely the prominent features of recent scientific progress in astronomy, geology, meteorology, physics, chemistry, mineralogy, botany, zoology, and anthropology. This latter plan was continued, though not altogether satisfactorily, down to and including the year 1888.

In the report for 1889 a return was made to the earlier method of presenting a miscellaneous selection of papers (some of them original) embracing a considerable range of scientific investigation and discussion. This method has been continued in the present report, for 1901.





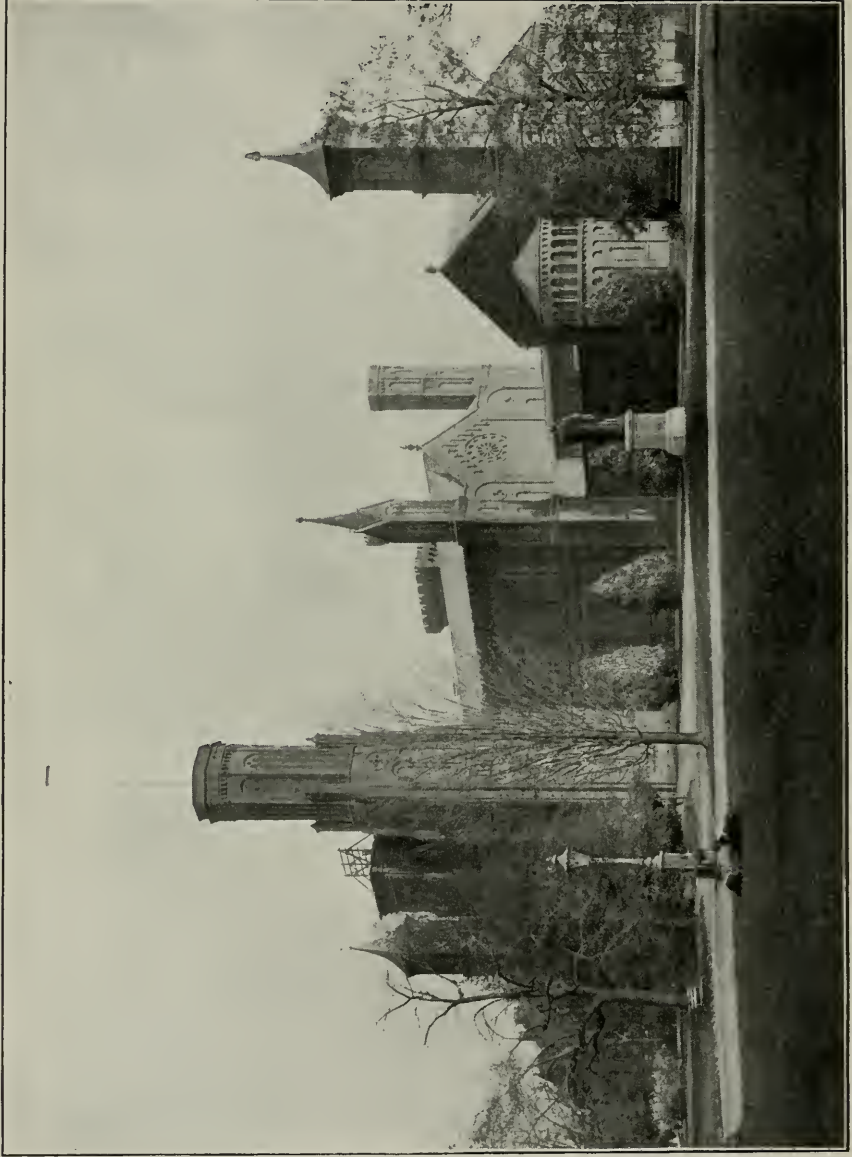

THE SMITHSONIAN BUILDING.



## THE SMITHSONIAN INSTITUTION.

---



“The advancement of the highest interests of national science and learning and the custody of objects of art and of the valuable results of scientific expeditions conducted by the United States have been committed to the Smithsonian Institution. In furtherance of its declared purpose—for the increase and diffusion of knowledge among men—the Congress has from time to time given it other important functions. Such trusts have been executed by the Institution with notable fidelity. There should be no halt in the work of the Institution, in accordance with the plans which

its Secretary has presented, for the preservation of the vanishing races of great North American animals in the National Zoological Park. The urgent needs of the National Museum are recommended to the favorable consideration of the Congress.” (President Roosevelt’s first message to Congress.)

In the first Smithsonian Report issued in the twentieth century it may not be amiss to tell the readers of this volume very briefly what the Institution is, how it came into being, and how it has fulfilled the purposes for which it was established.

In the popular mind the Smithsonian Institution is a picturesque castellated building of brown stone, situated in a beautiful park at Washington, containing birds and shells and beasts and many other things, with another large adjacent building, often called the Smithsonian National Museum. The Institution is likewise supposed to have a large corps of learned men, all of whom are called “Professors” (which they are not), whose time is spent in writing books and making experiments and answering all kinds of questions concerning the things in the heavens above, the earth beneath, and the waters under the earth.

Contrast this popular notion with the facts. The Smithsonian Institution is an “Establishment” created by an act of Congress which owes its origin to the bequest of James Smithson, an Englishman, a scientific man, and at one time a vice-president of the Royal Society, who

died in Genoa in 1829, leaving his entire estate to the United States of America "to found at Washington, under the name of the Smithsonian Institution, an establishment for the increase and diffusion of knowledge among men."

After ten years of debate in Congress, turning partly on the question whether the Government ought to accept such a bequest at all and put itself in the unprecedented position of the guardian of a ward, Congress accepted the trust and created by enactment an "Establishment" called by the name of the Smithsonian Institution, consisting of the President of the United States, the Vice-President, the Chief Justice of the United States, and the members of the President's Cabinet. It has also a Secretary, with varied functions, among others that of being the Keeper of the Museum.

Smithson's money, which amounted to over half a million dollars, and later to three-quarters of a million, a great fortune in that day of small things, was deposited in the United States Treasury, the Government afterwards agreeing to pay perpetually 6 per cent interest upon it.

In the fundamental act creating the Institution, Congress, as above stated, provided that the President and the members of his Cabinet should be members of the Institution, that is, should be the Institution itself, but that nevertheless it should be governed by a Board of Regents, composed of the Vice-President and Chief Justice of the United States, three Regents to be appointed by the President of the Senate (ordinarily the Vice-President), three by the Speaker of the House of Representatives, and six to be selected by Congress; two of whom should be residents of the District of Columbia and the other four from different States, no two being from the same State. The fundamental act further provides that the Secretary of the Institution already defined shall also be the Secretary of the Board of Regents. The Museum is primarily to contain objects of art and of foreign and curious research; next, objects of natural history, plants, and geological and mineralogical specimens belonging to the United States. Provision is also made for a library, and the functions of the Regents and of the Secretary were defined.

The preamble of this bill states that Congress has received the property of Smithson and provided "for the faithful execution of said trust agreeable to the will of the liberal and enlightened donor." It will thus be seen that the relations of the General Government to the Smithsonian Institution are most extraordinary, one may even say unique, since the United States solemnly bound itself to the administration of a trust. Probably never before has any ward found so powerful a guardian.

The first meeting of the Regents occurred on September 7, 1846, and in the autumn of the same year they elected as Secretary JOSEPH HENRY, then a professor at Princeton, known for his extraordinary





JAMES SMITHSON.

Founder of the Smithsonian Institution. From a painting by Johnes, 1816.





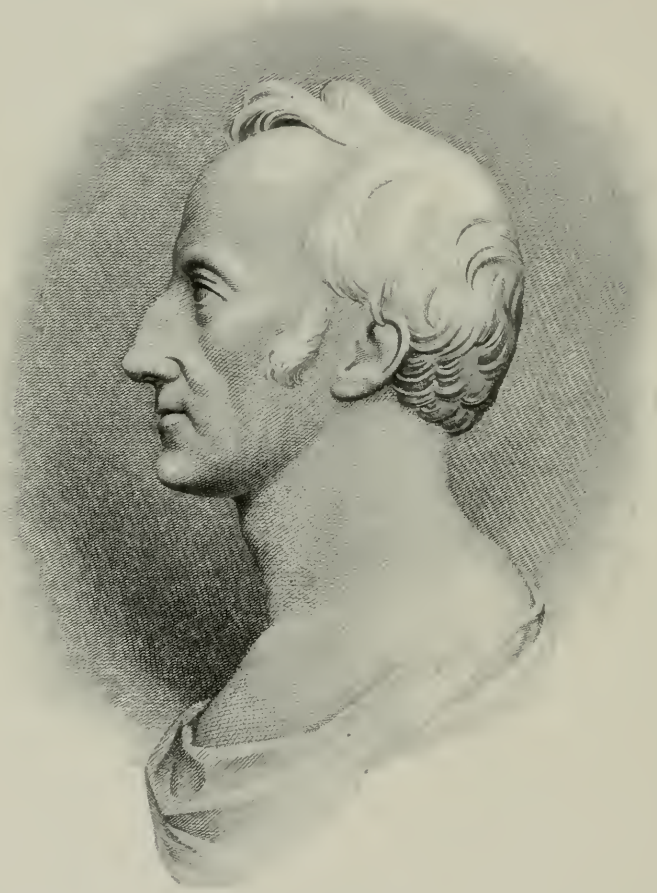

JAMES SMITHSON  
Founder of the Smithsonian Institution.

experiments on the electro-magnet, and other subjects relating to electricity. Under his guidance the Institution took shape. Its work at first consisted, in the main, of the publication of original memoirs, containing actual contributions to knowledge, and their free distribution to important libraries throughout the world; to giving popular lectures in Washington, publishing them, and distributing them to libraries and individuals; stimulating scientific work by providing apparatus and by making grants of money to worthy investigators, cooperating with other Government Departments in the advancement of work useful to the General Government, etc. These were the principal methods employed by Henry to carry out the purposes of Smithson, for the increase and diffusion of knowledge. Here, too, were initiated certain studies which afterwards became most fruitful and have resulted in important Government work, such as the present Weather Bureau, among others. The beginning of cooperation in library work was at this Institution. At the same time many—we might almost say most—of the present scientific activities of the Government have grown out of it or been stimulated by it. Experiments in fog signaling, in the acoustics and ventilation of public buildings, and in numerous other subjects, were inaugurated. In fact, in these earlier days, with one or two exceptions, the Smithsonian was the sole representative of active scientific work directly or indirectly connected with the United States Government. Its influence upon the character of private scientific work, too, was very great, since half a century or more ago the avenues for publishing were few, and the funds for the purpose slender.

Gradually, out of the collections which had been kept in the Patent Office, the private collections of Smithson, and of appropriations of his money made by the Regents, and largely also through the results of the great exploring expedition of Captain Wilkes, there grew up a Smithsonian Museum, one which was exclusively cared for from the Smithson fund; but which, partly through the greater activity of the Government surveys and partly through the gifts of private individuals, and also through the valuable objects presented to the United States Government by foreign nations at the close of the Centennial at Philadelphia in 1876, brought about the establishment of what is now known as the United States National Museum of the Smithsonian Institution, which is under control of the Regents of the Institution, for which a building was provided, and which now receives direct support from Congress. This Museum has now the matter belonging to the original Institution collected by the Smithsonian's own observers, with much more secured through the General Government, making in all over 5,000,000 specimens, and is the foremost collection in the world in everything that relates to the natural history, ethnology, geology, and paleontology of that portion of North America now the

United States, besides containing many valuable series from other countries. The collections have been visited by over 7,500,000 persons, and the Institution has carried selections of its specimens to every large exhibition held in the United States, and distributed 850,000 specimens to colleges and academies, thus powerfully stimulating the growth of museums large and small in every section of the country.

The publications of the Smithsonian have been in several series, mostly to convey to specialists the results of its original scientific investigations and to thus represent the first half of its fundamental purpose "for the *increase* of knowledge," and, subordinately, others to include handbooks and indexes useful to students, and some publications which, while still accurate, contain much information in a style to be understood by any intelligent reader, and thus represent the second half of the founder's purpose for the "*diffusion* of knowledge." Many valuable publications, too, have been issued by the Museum and the Bureau of Ethnology, and recently by the Astrophysical Observatory. In all, 265 volumes in over 2,000,000 copies and parts have been gratuitously distributed to institutions and private individuals, these works forming in themselves a scientific library in all branches.

Partly by purchase, but in the main by exchange for these publications, the Institution has assembled a library of over 150,000 volumes, principally of serial publications and the transactions of learned societies, which is one of the notable collections of the world. The major portion of it has been since 1866 deposited in the Library of Congress, with which establishment the most cordial and mutually helpful relations subsist.

In 1850 SPENCER FULLERTON BAIRD, a distinguished naturalist, was elected Assistant Secretary of the Institution. To him the great activity in natural history work was due, and by him the Museum was fostered, he being greatly aided from 1875 by a young and enthusiastic naturalist, GEORGE BROWN GOODE. Secretary Baird initiated in the Smithsonian Institution those economic studies which led to the establishment of the United States Fish Commission.

As another means of diffusing knowledge there was early established the bureau of international exchanges, originally intended simply for the proper distribution of the Smithsonian's publications, but which gradually assumed very wide proportions, becoming no less than an arrangement with learned societies throughout the world to reciprocally carry free publications of learned societies, or of individual scientific men, intended for gratuitous distribution. This system was afterwards taken up by various governments which, through treaties, bound themselves to exchange their own publications in the same way. Since the inauguration of this service, 5,000,000 pounds weight of books and pamphlets have been carried to every portion of America and of the world. The Institution existing not only for America, in which it has



JOSEPH HENRY.

First secretary of the Smithsonian Institution, 1846-1878.









SPENCER FULLERTON BAIRD.

Second secretary of the Smithsonian Institution, 1878-1887.

over 8,000 correspondents, but for the world, has throughout Europe, Asia, Africa, and the islands of the sea, nearly 28,000 correspondents—more without the United States than within—justifying the words “Per Orbem,” as the device on the Smithsonian seal.

Other work has been intrusted to the Institution by the Government, such as the Bureau of American Ethnology, for studies relating to the aborigines of this continent; the Astrophysical Observatory, which for ten years has been chiefly devoted to the enlargement of Newton's work on the spectrum, and the National Zoological Park. The establishment of the latter was intended primarily to preserve the vanishing races of mammals on the North American continent; but it has also assumed the general features of a zoological park, affording the naturalist the opportunity to study the habits of animals at close range, the painter the possibility of delineating them, and giving pleasure and instruction to hundreds of thousands of the American people. These two latter establishments are due to the initiative of the present Secretary, Mr. S. P. LANGLEY, elected in 1887; a physicist and astronomer, known for his researches on the sun, and more recently for his work in aerodynamics. While the fund has been increased of later years by a number of gifts and bequests, the most notable being that of Mr. Thomas G. Hodgkins of a sum somewhat over \$200,000, its original capital, once relatively considerable, has now, in spite of these additions, grown relatively inconsiderable where there are now numerous universities having twenty times its private fund. It threatens now to be insufficient for the varied activities it has undertaken and is pursuing in every direction, among these the support of the higher knowledge by aiding investigators everywhere, which it does by providing apparatus for able investigators for their experiments, etc. Investigations in various countries have been stimulated by grants from the fund. It has been the past, as it is the present, policy of the Institution to aid as freely as its means allowed, either by the grant of funds or the manufacture of special apparatus, novel investigations which have not always at the moment seemed of practical value to others, but which subsequently have in many instances justified its discrimination in their favor and have proved of great importance.

The growth of the Institution has been great, but it has been more in activity than in mere bigness. The corner-stone was laid fifty years ago. In 1852 the entire staff, including even laborers, was 12. In 1901 the Institution and the bureaus under it employed 64 men of science and 277 other persons. These men of science in the Institution represent very nearly all the general branches, and even the specialties to some extent of the natural and physical sciences, besides history and the learning of the ancients; and it may perhaps be said that the income of the Institution (which, relatively to others, is not one-tenth

in 1901 what it was in 1851) has been forced to make good, by harder effort on the part of the few, what is done elsewhere in the Government service by many.

The private income of the Smithsonian Institution is not quite \$60,000, but it controls the disbursement of about \$500,000 per annum appropriated by the Government for the bureaus under its charge.

Certain other functions difficult to describe are still of prime importance. The Smithsonian is called on by the Government to advise in many matters of science, more especially when these have an international aspect. Its help and advice are sought by many thousands of persons every year, learned societies, college professors, journalists, and magazine editors, and thousands of private individuals, seeking information, which is furnished whenever it can be done without too serious a drain, though naturally a percentage of the requests is unreasonable. It has cooperated with scientific societies of national scope, like the American Historical Association, and has stimulated the growth of a number of the Washington scientific societies, and it may be said to teem with other activities.

The Regents control the policy of the Institution, and the Secretary is their executive officer. Since the beginning the Regents have been selected from among the most distinguished men in public life and in the educational and scientific world. Their roll contains the names of the most distinguished American citizens for half a century.

An unwritten policy has grown up which, without instructions or regulations, has been of profound influence in the work. The Smithsonian Institution does not undertake work which any existing agency can or will do as well. It does not engage in controversies; it limits its work to observation and the diffusion of ascertained knowledge, not to speculation. It preserves an "open mind" for all branches of knowledge and considers any phenomena which are the object of serious study within its purview. Its benefits are not confined to Washington nor to the United States, but as far as consistent are extended to all men.

Its Secretaries, Assistant Secretaries, and scientific officers have from the beginning—long before a classified service existed—been elected and appointed for merit, and for that alone. No person has ever been appointed on the scientific staff for any political reason or consideration.

It is impossible to look into the future. The Smithsonian Institution has a remarkable organization for the administration of funds for the promotion of science; yet amidst the great benefactions of the past quarter of a century relatively few have come to it. Its activities could be still further increased if it had greater means under its control, and the Regents, because of the peculiarly independent position they hold, can be of great public service in suggesting



SAMUEL PIERPONT LANGLEY.

Third secretary of the Smithsonian Institution. Elected in 1887.



the channel into which gifts for scientific purposes might be directed, even if they do not see their way clear to accepting such donations for the Institution itself.

For the National Museum a great new building is a prime necessity. The Museum has practically reached a point where it is physically impossible that it should grow under present conditions.

Secretary Langley has for several years past been urging upon the Government the dispatch of several expeditions for capturing the species of large mammals so rapidly being destroyed in the United States and Alaska; but even without this, the National Zoological Park, with its relationships to the other great national parks, is destined to be one of the great collections of the world.

The Bureau of American Ethnology, which since its organization has devoted itself to the aborigines of this continent, may have new work to do in Porto Rico and in Hawaii.

Among still other activities, of which there is now but a premonition, a National Gallery of Art (provided for by Congress in the original charter) may be alluded to.

The past of the Smithsonian Institution is secure, its present is known to all men, and it looks forward to the future in the belief that it will worthily continue under whatever changing conditions to "increase and diffuse knowledge among men."







## SOME RECENT ASTRONOMICAL EVENTS.

By C. G. ABBOT.

The year 1901 has been a remarkable one in the history of astronomy for the number of important observations and discoveries which have been recorded. I have selected for the following account six, perhaps, the most interesting. These are (1) recent determinations of stellar motion in the line of sight; (2) advances in astronomical photography; (3) the measurement of the heat received from the stars; (4) the observation of the planet Eros; (5) the total solar eclipse of May 18, 1901, and (6) the history of the new star in Perseus.

### 1. RECENT DETERMINATIONS OF STELLAR MOTION IN THE LINE OF SIGHT.

It is now over thirty years since Sir William Huggins made the earliest application of Doppler's principle to the problem of determining the velocity of motion of the stars in the line joining the star with the observer, technically called the line of sight. Before this all measures of stellar motion had been by the comparison of accurate positions obtained many years apart, and giving thus the stars' "proper motion" or motion at right angles to the line of sight. The principle of Doppler, however, offers a means of discovering the other component of stellar motion, for in accordance with it the apparent wave length of light is increased or diminished by the recession or approach of the source, just as a locomotive whistle becomes of higher pitch as it comes toward us and lower as it goes away. It requires, then, in theory, but the comparison of well recognized lines in the stellar spectra with the corresponding ones in the spectrum of a terrestrial source, to see whether or not the star lines are shifted toward the blue or the red, together with a measurement of the amount of this shifting to decide if the star is approaching or receding from us, and at what rate. In practice, however, the displacements caused by stellar motion are so slight that the effects of a varying temperature of the apparatus and of other causes make this one of the most difficult fields of astronomical investigation.

After Sir William Huggins's first experiments in 1868 and those of Professor Vogel at Potsdam in 1871 the work was taken up at Greenwich and pursued for thirteen years. Those early results were but rough, however, and we owe to the introduction of astronomical photography the present advances in this as in so many other lines. The introduction of photography, and with it the first results of great value for accuracy, date from the observations of Vogel at Potsdam in 1887. Not long after this Professor Keeler, then director of Allegheny Observatory, obtained his famous spectrographic proof that the rings of Saturn consist of small bodies revolving about the planet in obedience to Kepler's laws and are not continuous rigid sheets of matter as they appear to be in a telescopic view.

The most celebrated instrument used for these line of sight researches is that known as the Mills spectrograph of the Lick Observatory, with which Professor Campbell, the present director, has made and is still continuing his noted line of sight determinations for all the brighter stars of the northern hemisphere. An illustration of this instrument attached to the 36-inch equatorial is here given (Pl. I). The reader may see in the illustration what care is used to avoid temperature disturbances. With the Mills spectrograph the accuracy of Professor Campbell's determinations has become very great, so that the probable error of a determination from a single photograph may be, for stars having favorable spectra, far within a single kilometer per second.

While most of the stars observed have line of sight velocities not exceeding 10 kilometers per second, certain of them give evidence of a far greater rapidity of motion, amounting in the case of  $\zeta$  *Herculis* to no less than 70 kilometers per second (or nearly 45 miles). Still more interesting are the variable velocities reported in numerous cases. From evidence of this kind Professor Campbell has concluded, for instance, that the Pole Star is not single as it appears in the telescope, but consists of a system of no less than three bodies revolving about in mutually influenced orbits.

It has become possible with the spectroscope not only to prove that several stars exist where only one is seen with the most powerful telescopes, but to determine the time of revolution of such a spectroscopic pair in its orbit, and even with considerable certainty to determine the form and size of this orbit and its inclination to the plane of the ecliptic, although, as I have said, the separate stars are so close and their orbit so circumscribed as never to be seen.

Line of sight determinations have now become one of the most important features of astrophysical study. A new telescope is to be devoted to this purpose at the Cape of Good Hope Observatory. The Astrophysical Observatory at Potsdam has very recently obtained a new stellar spectrograph of the most approved construction. The Lick Observatory is establishing a branch observatory in South Amer-

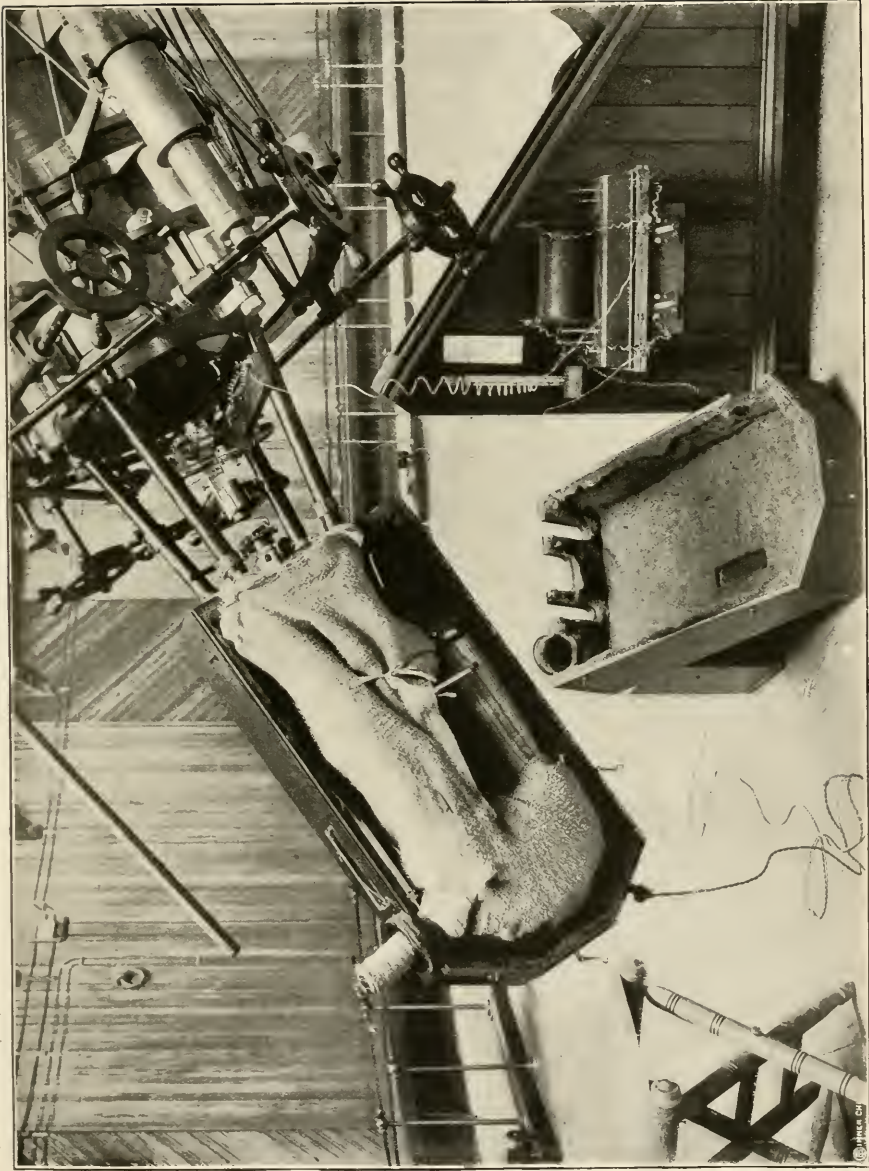

THE MILLS SPECTROGRAPH OF THE LICK OBSERVATORY.



ica to complete the spectrographic survey of the heavens, and the great equatorial at Yerkes Observatory has within a few months been fitted with a new stellar spectrograph of the greatest perfection.

## 2. RECENT ADVANCES IN ASTRONOMICAL PHOTOGRAPHY.

It was formerly the custom, in the time of Sir William and later of Sir John Herschel, to employ reflecting telescopes for stellar observations. With the more recent high development of refracting telescopes, mirrors became superseded largely by lenses for the most refined work. It is well known to what extraordinary size and perfection telescope objectives have risen, so that in the United States alone we have perhaps as many as half a dozen of over 2 feet clear aperture, the largest being the 40-inch equatorial of the Yerkes Observatory. But while the substitution of refracting for reflecting instruments thus went on, the introduction of photography in astronomical work gave an impetus which has since led to the revival of the use of reflectors.

The advantage of the latter is due in part to the fact that reflecting instruments bring all rays of whatever wave length to the same focus, while refractors can only be corrected to bring a certain limited number of wave lengths to a focus at any given plane. When refracting instruments are constructed for visual purposes it is customary to correct the lens in such a way that the rays which affect the eye most intensely shall be brought to a sharp focus, neglecting so far as is necessary the violet rays which are most active photographically. It will be readily seen therefore that a visual refracting telescope is not suitable for the most exact photographic operations. Hence it has been the custom, followed at the Lick Observatory, at the Astrophysical Observatory at Potsdam, and at many other observatories where great refractors are employed, to have an additional lens, either used as a corrector for the visual objective, or wholly substituted for it, to be employed solely for photographic purposes. This has necessitated a very great initial expenditure of money as well as no inconsiderable waste of time and danger to the instruments in the substitution of lenses, as the instrument is changed from visual to photographic uses.

The fact that a reflecting telescope with all its appurtenances, of equal light-gathering power to a great refractor and without the defect of chromatic aberration, can be made at a small fraction of the cost merely of the lens itself, has therefore led several large observatories to yield their great equatorials chiefly to visual and spectroscopic purposes, supplementing their equipment for stellar photography by the use of a reflector with wholly separate driving mechanism and dome.

Against the very great advantage of a reflector in point of cost, however, there is to be offset the fact that the extent of the field where the definition remains good at the focus of a large lens is far

greater than the corresponding field in the focus of a great mirror. But notwithstanding this disadvantage, reflectors have more and more come into use for photographic purposes within recent years, and some of the most beautiful and striking photographs of the nebulae and star clusters ever made were obtained with the Crossley reflector in the last months of his life by Professor Keeler, director of the Lick Observatory at Mount Hamilton, California. Since his untimely death the instrument has been continued in use and is now giving excellent results.

More recently still Mr. Ritchey, of the Yerkes Observatory, has designed and prepared with his own hands a reflecting telescope of slightly smaller dimensions than the Crossley instrument, and is now obtaining photographs of nebulae, star clusters, and other objects requiring much light-gathering power but no great extent of field, which are unexcelled for excellence. The illustration (Plate II) shows the great nebula in Cygnus as photographed by Mr. Ritchey with an exposure of three hours. The faintest stars shown in the original are more than 10,000 times fainter than the unaided eye can see. Plate III includes two drawings from photographs by Mr. Ritchey of the nebula round Nova Persei taken with the same instrument.

I have spoken of the large expense and inconvenience attending the use of refracting instruments for both visual and photographic purposes. In preparing the great Yerkes refractor of 40 inches aperture no provision was made for its employment as a photographic telescope, but very recently, owing to the great advance made by commercial dry-plate manufacturers in the preparation of photographic plates sensitive in the yellow and green portions of the spectrum—that is to say, those portions where the eye is the most sensitive—it became possible, if the imperfectly focused blue and violet rays of the instrument could be cut off, to use the telescope without prejudicially long exposures for photographic purposes. Mr. Ritchey has, accordingly, employed a color screen close to the photographic plate, by means of which these prejudicial rays are eliminated; and by the further use of a most efficient following apparatus, also of Mr. Ritchey's design, there has recently been taken with this telescope, originally intended only for visual and spectroscopic purposes, extraordinarily perfect astronomical photographs (Pl. IV). This marks a most important advance in astronomical photography, for it thus becomes possible, with a very trifling expense, to use the great visual equatorials of the world with perfect success as photographic telescopes.

Before passing from the subject of celestial photography I wish to mention a combination of the refracting and reflecting schemes which is now being employed with great success. It will be remembered that one of the most celebrated features of the Paris Exposition was the "Great Telescope," so-called, and that this was employed not



THE GREAT NEBULA IN CYGNUS.

PHOTOGRAPHED BY G. W. RITCHEY, WITH THE TWO-FOOT REFLECTING TELESCOPE OF THE YERKES OBSERVATORY. EXPOSURE THREE HOURS.





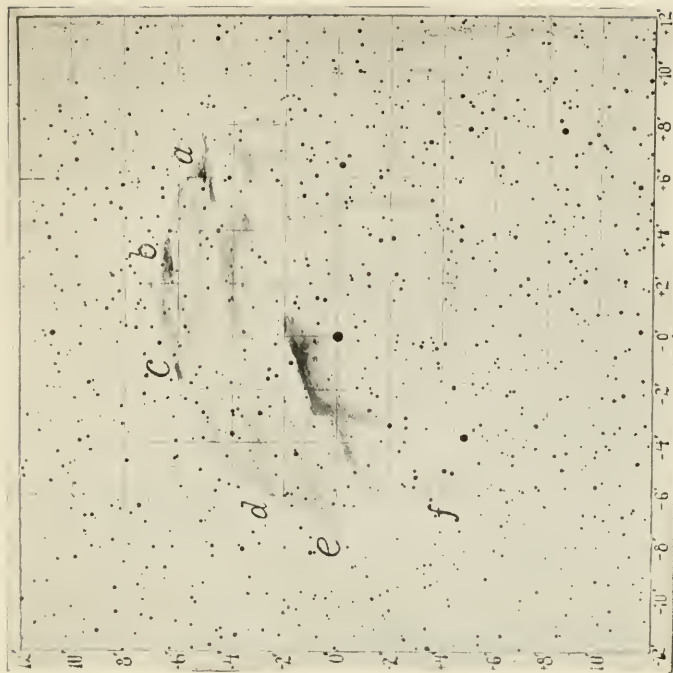
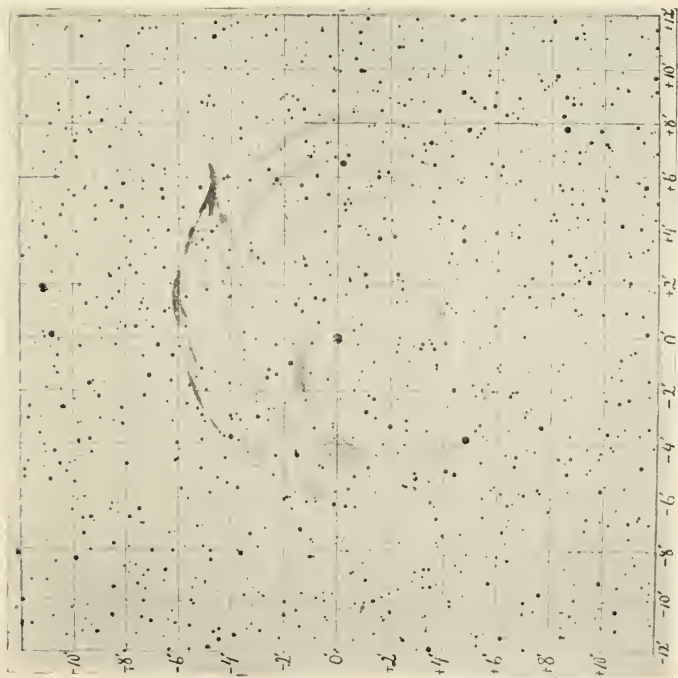

DRAWINGS FROM PHOTOGRAPHS BY MR. RITCHEY OF THE NEBULA ROUND NOVA PERSEI.



pointing toward the celestial object, but pointing rather at a great mirror which itself reflected the light to the lens. This combination of the lens and the mirror is coming increasingly into favor. It was used with advantage, as the readers of last year's report remember, by the Smithsonian eclipse expedition of 1900, and with no less success by observers of that eclipse from other places, notably by Professor Barnard of the Yerkes expedition.

The advantage of this arrangement consists chiefly in that the telescope is immovable and therefore not so much subject to the shaking of the ground, bad following of the clock, or to flexure of the tube of the lens or of the lens itself, all of which are liable to seriously affect the steadiness and perfection of the image of a great equatorial. Of course these sources of error all come in to disturb the reflecting mirror which is placed in front of the telescope; but yet, owing to the compactness and relatively small weight of the apparatus which is there driven, these sources of error may be much diminished. Besides these advantages we have the not inconsiderable further gain that the visual or photographic observer can carry on his operations with perfect comfort and convenience, owing to avoiding the necessity of following the moving eye end of an equatorial. In a recent visit to the Yerkes Observatory I had the pleasure of seeing the beginnings of very large telescopes of this pattern which Professor Hale designs to employ for the most delicate and far-reaching photographic and radiometric investigations.

### 3. THE MEASUREMENT OF THE HEAT RECEIVED FROM THE STARS.

Attempts were made as early as 1869 and 1870 by English astronomers to obtain evidence of the heat received at the earth from the brightest stars. These experiments were carried out with the aid of the thermopile, then the most sensitive form of heat-measuring apparatus known.

Since 1880 there have been devised, however, as many as four instruments far more sensitive than the old-fashioned thermopile. These are the bolometer, the radiomicrometer, the improved thermopile of Rubens, and the radiometer, which last has reached its greatest sensitiveness in the hands of Prof. E. F. Nichols.

In 1888 Prof. C. B. Boys, with his then newly invented radiomicrometer, repeated the earlier observations on the heat of the brighter stars, and while the earlier observers had convinced themselves of discernible heating effects, he, with his far more sensitive arrangements, came to negative results. As showing the great sensitiveness of his apparatus and the therefore extreme minuteness of the amount of heat received from the stars, it need only be said that in the absence of atmospheric absorption a candle placed at almost 2 miles distance would have been perceived by him.

Notwithstanding this discouraging evidence, the question was again taken up within the last two or three years by Professor Nichols with his radiometer. Before mentioning his results it will be of interest to briefly describe that instrument. The principle upon which it is based is the well-known one of the Crookes revolving vanes, familiar in the collections of apparatus exhibited in the physical cabinets of academies and colleges. In this interesting toy a pair of small metallic vanes, blackened on opposite sides and fixed perpendicularly upon a light arm, itself horizontal and delicately poised at its center upon a vertical axis, is caused to rotate in a vacuum by the influence of light.

The Nichols radiometer is merely this old instrument adapted to measure the intensity of the impinging rays. An idea

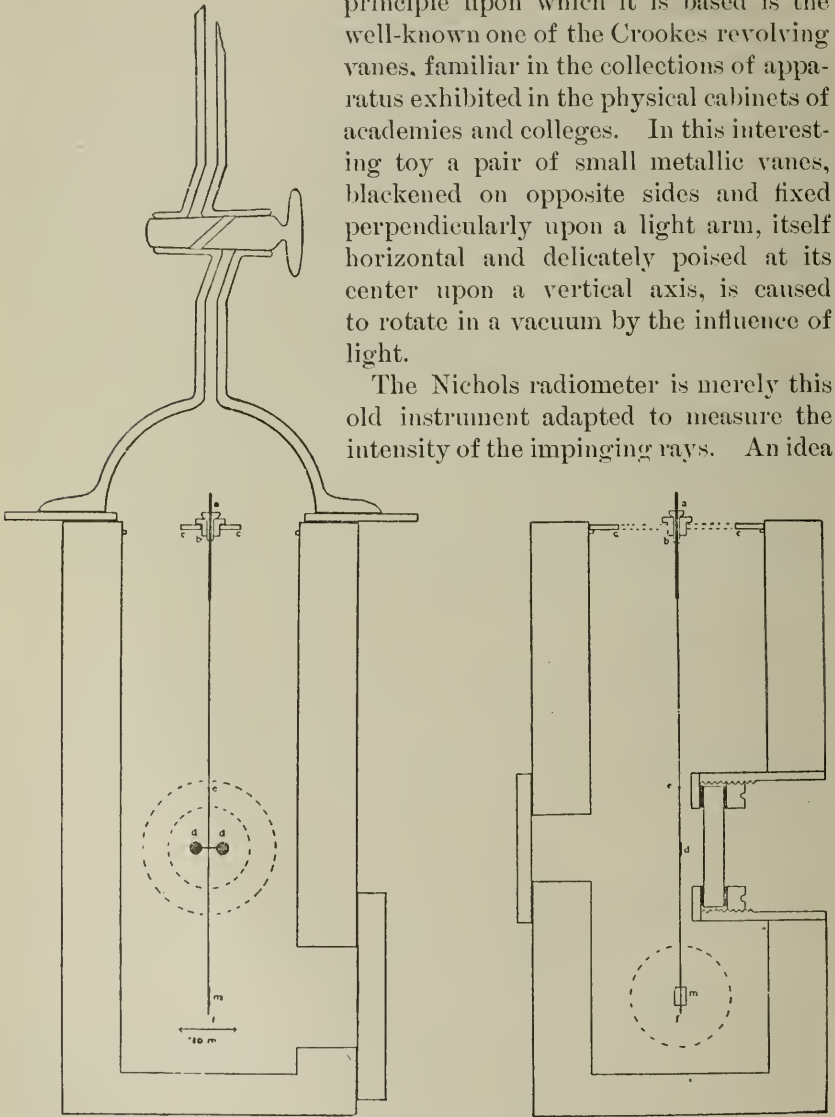

The Nichols radiometer. From *Astrophysical Journal*, Vol. xiii, No. 2, March, 1901.

of its construction is given by the accompanying diagram. The vanes, made very small, are fastened at the ends of a slight stem of glass about one-fourth of an inch long, which in turn is fixed at right angles to a second longer glass stem furnished with a very light mirror and sus-



LUNAR CRATER THEOPHILUS AND SURROUNDING REGION.

PHOTOGRAPHED BY G. W. RITCHEY, WITH THE FORTY-INCH VISUAL TELESCOPE, YERKES OBSERVATORY. EXPOSURE ONE-HALF SECOND.  
SCALE ABOUT 1 METER TO LUNAR DIAMETER.



pended by an extremely thin quartz fiber. All is inclosed in a metal case, with a glass window opposite the little mirror, so as to observe the deflections of the vanes by the telescope and scale method, and a second window of fluorite or other material transmissible to the long wave-length radiations is inserted opposite the vanes to admit the rays to be measured. The case is air-tight and may be exhausted to any degree. The sole force which keeps the vanes at the zero of position when uninfluenced by radiation is the torsional elasticity of the quartz fiber, and this resists the rotation of the vanes and returns them to their original position when turned temporarily from it by the influence of radiation.

An extraordinary degree of sensitiveness of this instrument was indicated by experiments which were made on the heat of a candle situated 2,000 feet from the concave mirror which focused its rays upon the radiometer. The feeble radiations of the candle at this great distance sufficed to turn the radiometer through nearly a hundred scale divisions, and even the face of an observer, when placed in the position before occupied by the candle, produced a deflection of 25 scale divisions. As a tenth of a single scale division could readily be observed, it will be seen, to speak figuratively, that with the radiometer one might note the approach of a friend while yet some miles distant, merely by the glow of his countenance.

Correcting the observation upon the candle for the absorption of the earth's atmosphere in the layer between it and the radiometer, it was found that in the absence of the atmosphere, a single candle at upward of 16 miles could have been detected, so that the instrumental equipment was far more sensitive than that used by Professor Boys in the negatively resulting stellar observations already alluded to.

Experiments were performed upon the radiations of the stars Vega and Arcturus, and on the planets Jupiter and Saturn. The heat of each of these objects was distinctly recognized, and caused, in the mean, deflections of 0.51, 1.14, 2.38, and 0.37 scale divisions, respectively, when approximately reduced to zenith. Thus the relative thermal effects of Vega, Arcturus, Jupiter, and Saturn are as 1:2.2:4.7:0.74. This, it will be seen, is quite appreciably different from their relative brightness to the eye, a circumstance which may, with additional experiments, lead to interesting conclusions regarding the nature of the radiation received from these several objects.

#### 4. THE OBSERVATIONS OF THE PLANET EROS.

The minor planet Eros, it will be recalled, was discovered by Witt, of the Urania Observatory at Berlin, August 13, 1898. When after several observations its approximate orbit was computed, this was found to be so highly eccentric as to differentiate this new planet from the many other asteroids with which it had been provisionally classed.

So highly eccentric indeed was the planet's orbit that, although upward of 90,000,000 miles distant at unfavorable oppositions, when nearest the earth it may come within about 15,000,000 miles, and is on these occasions, so far as is known, our nearest celestial neighbor after the moon. This peculiarity caused the planet to become an object of great interest on account of its possible use in the more accurate determination of the sun's distance from the earth, for an object at 15,000,000 miles distance has a very appreciably different position among the stars if viewed from opposite ends of the earth's diameter—no less a parallax indeed than 100 seconds of arc. Consequently its actual distance from the earth could probably be determined with very great accuracy, and this distance when thus fixed could be used indirectly to obtain a new estimate of the sun's distance from the earth, with an accuracy possibly exceeding that of earlier methods.

Search was immediately instituted by Prof. E. C. Pickering, the director of Harvard College Observatory, through the continuous photographic record of the stars which is kept up at that observatory, for earlier positions of the planet, and such were soon found among plates taken in 1893, 1894, and 1896. From these observations, which, taken with those made in 1898, follow the planet through a considerable range of time, a very accurate orbit was computed.<sup>a</sup>

The orbits of Eros and the earth were found to be of such a form that their next reasonably close approach would occur in November, 1900, and while their distance at this time was indeed considerably greater than their least possible distance of 15,000,000 miles, yet it was determined to institute at that opposition a thorough parallax campaign to be taken part in by all the observatories in the world fitted with instruments suitable for this purpose, for it would be necessary to wait upward of twenty years for the minimum distance to occur. Fully 50 observatories took part in this parallax campaign, continuing observations from October through to about the 1st of February. These observations were in part photographic, in part visual, and taken at stations as far apart as the Cape of Good Hope, South Africa, and Helsingfors, in Finland, and indeed it might almost be said that there was no habitable quarter of the earth which was not represented by observers. It is yet too early to say what will be the results, but it is hoped that they may lead to a very excellent determination of the distance of the sun.

---

<sup>a</sup>As an evidence of the value of the photographic records of Harvard College Observatory, it was recently remarked by Professor Pickering that "if, in the future, any other object like Eros should be discovered, we have at this observatory the means of tracing its path since 1890, during the time in which it was moderately bright, with nearly as great accuracy as if a series of observations had been taken of it with a meridian circle."



But in connection with these observations were others which are of remarkable interest, for it appeared that the brightness of the planet varied extraordinarily. In February, 1901, it was found by European astronomers that rapid variations occurred to the amount of two whole stellar magnitudes, which would be equivalent to a variation of 600 per cent! More recent observations show that the range of brightness diminished so that at the middle of May there was apparently less than a tenth of a magnitude variation. The extraordinary amount of these fluctuations in the brightness of a planet almost baffles explanation, and several theories have been tentatively proposed, none of which, however, as yet is established. Among these explanations are that the planet is of unequal reflecting power on different portions of its surface: that the variation is due to the inclination of its axis taken in connection with a very eccentric form; or that it is even double, as has been assumed by M. André and others, by whom it has been suggested that there may be two single bodies alternately eclipsing each other. In any of these explanations it is extremely difficult, as has been said, to account reasonably for the very remarkable variations of brightness. The question is complicated by the velocity of light, the varying distance of the sun and the earth, the phase of the planet and the direction of its axis of rotation, all of which, while they make numerical computations arduous, yet may furnish valuable checks on the trustworthiness of any theories which may be proposed.

#### 5. THE TOTAL SOLAR ECLIPSE OF MAY 18, 1901.

The total solar eclipse of May 18, 1901, which occurred over a belt extending from the island of Mauritius across the Indian Ocean and through several of the large islands of the Dutch East Indies was at its maximum over six minutes long, and hence gave rise to many observing expeditions, although the chances for favorable observing weather were regarded as precarious in these tropical regions. Most of the observers selected the west coast of the island of Sumatra for their post of observation, though some went to Mauritius, others to an island off the east coast of Sumatra, and still a few others, I believe, to Borneo. The nations represented on these expeditions included the Netherlands, the United States, Great Britain, France, Russia, and Japan. The United States sent the greater number of parties, while the Netherlands, on account of its control of the island of Sumatra, where the observations were conducted, had the most numerous observers and the most extensive programme.

The United States observers occupied seven stations, all on or near the west coast of Sumatra, excepting the Amherst College expedition, which was stationed on a small island east of Sumatra.

England sent three parties, one stationed on the island of Mauritius, and the other two on or near the west coast of Sumatra.

France was represented by one observer, Russia by one, Japan by several, while the Netherlands made very extensive preparations, including the participation of army officers, a portion of its scientific staff from Batavia, and a party of three from the Netherlands proper.

The Smithsonian Institution, as will be recalled by the readers of the report for 1900, had, in May of that year, observed the total eclipse at Wadesboro, North Carolina, and had obtained, among other results of interest, bolometric evidence indicating a probable low temperature of the corona, while on a single photograph of the region near the sun there had been found certain star-like images which were suspected to be due to as yet undiscovered planets. The expedition to Sumatra was undertaken to verify these tentative results.

These two kinds of research proved very attractive to other parties as well, for the Lick Observatory, the Massachusetts Institute of Technology, one of the English parties, and the Dutch, all had apparatus for the photographic search after intramercurial planets, and the Dutch and French also used apparatus designed for the thermal study of the radiation of the corona.

The United States Naval Observatory expedition was largely spectroscopic in character, while at the same time including first-class outfits for the photography of the corona. One of these especially deserves mention, for it was undoubtedly the most complete and well-arranged apparatus ever used for coronal photography. I refer to that of Professor Barnard, of the Yerkes Observatory, an invited member of the Naval Observatory expedition. Professor Barnard had the same optical apparatus which he used at Wadesboro, North Carolina, in 1900, but the photographic plates were much more numerous, owing to the longer eclipse, and included one plate 40 inches square, for a very long exposure.

The spectroscopic work of the Naval Observatory was done mainly with diffraction gratings, a rather new departure in eclipse photography, and the programme included the photography of the flash spectrum and of the coronal spectrum. For the latter, Dr. Gilbert had polariscopic apparatus of Professor Wood's design, with which it was hoped to prove the existence of Fraunhofer lines.

The Dutch, as has been said, covered a very wide range of observation. Their army officers, at various stations in the path of totality and near it, made meteorological and general observations, while their main party had an elaborate outfit for every kind of eclipse research.

The English, as did the Naval Observatory party, made a main feature of spectroscopic work, including also direct photography of the corona and of the regions thereabouts, and other general observations.

Before proceeding to the discussion of the eclipse itself, a few remarks upon the trip, in which I had the good fortune to participate, may be of interest. The two Government expeditions of the United



SUMATRA. BY LAKE SINGKARAK.



SUMATRA NATIVE DWELLING.



States, while independently sent out, proceeded together in entire harmony and good fellowship, and added, so far as was in their power, to each other's success and enjoyment.

Proceeding from Washington on the 5th day of February, 1901, we reached San Francisco on the 11th of the month. Further passage was arranged for upon the army transport *Sheridan* from San Francisco, by way of Honolulu, to Manila. The expeditions left San Francisco on February 16 and after a somewhat rough passage (during which, as we afterwards learned, the ill-fated steamer *Rio Janeiro* went ashore at San Francisco) we reached Honolulu, where we stayed several days. The interest and enjoyment of our stay there was greatly increased by the kindness and attentions of the Social Science Club of Honolulu.

Leaving Honolulu, we reached Manila March 18, and after a stay of a few days there, during which very interesting visits were made to the office of the United States Coast and Geodetic Survey and to the Manila Observatory, we proceeded by the U. S. ship *General Alava*, which had been detailed by the Navy Department for the purpose, direct from Manila to Padang, on the west coast of Sumatra.

We, of course, being without exception northern hemisphere observers, took great interest in seeing the unfamiliar constellations rise out of the south, and in seeing our familiar north star gradually disappear. The officers of the ship took every possible care for our comfort, and we were also entertained (and some of us immersed) upon passing the equator, by the court of His Majesty Neptunus Rex, who came aboard in true man-of-war style. Another incident of great interest was the sight of the famous volcano Krakatau, in the Strait of Sunda, whose eruption in 1883 is so well remembered as the occasion of great loss of life and also of interesting astronomical and meteorological occurrences, due to the volcanic dust which was thrown up to such extreme heights that it became distributed all over the world.<sup>a</sup>

We reached our destination at Padang April 4, near sunset, and while the passage from Manila had been most quiet and delightful, yet

---

<sup>a</sup> It will be recalled that the explosion, which occurred on Monday, the 27th day of August, 1883, and was heard several thousand miles, took place about 10 o'clock in the morning, as determined, not by any observers, for none such survived to tell what they saw, but by meteorological observations of the air waves which, proceeding from the volcano, went round the world, were reflected back from the antipodes, and re-reflected from the volcano, seven complete passages of the globe being distinguished before they wholly subsided. Furthermore, a water wave was thrown up, at some points as much as 150 feet above sea level, on the sides of the Strait of Sunda; and this water wave was observed at the Cape of Good Hope, at Cape Horn, and even in the English Channel, no less than 11,000 miles distant. The Strait of Sunda was greatly altered in its configuration, a channel over a hundred fathoms deep existing where previously there was a portion of a mountain over a thousand feet above sea level, while in addition a wholly new island was formed.

the remembrance of the inner harbor will always stay with me as the type of absolute peace. Scarce a ripple stirred its surface, scarce a sound came to our ears, and when a little later we heard the monotonous but sweet native music floating over the water the feeling of quietness and repose was, if possible, augmented.

Our reception by the consular agent of the United States, Mr. C. G. Veth, on board ship early next morning, was most cordial, and nothing could exceed in kindness the care and generosity and the assistance which this gentleman gave us, not only on that day but upon every succeeding day until we left the island. We learned from him that Governor Joekes and other officials of the Dutch Government had put all possible conveniences at our disposal, including the free passage both for ourselves and our instruments, at any time during our stay, all over the system of Government railroads throughout the western coast of Sumatra.

The choice of stations was of course our next care. In the publications of the Netherlands Eclipse Committee, a series of meteorological observations had been recorded at many stations in Sumatra, and taking into consideration these, the facility of transportation of apparatus, and other matters, and after a reconnaissance of several days, I determined on my part to locate at a small place in the interior named Solok, and Professor Skinner of the Naval Observatory made the same choice for his principal party. Here there is a fort, not at present occupied, which, with its inclosure, was placed wholly at our disposal by the Assistant Resident of Solok, Mr. Derx. This fort was admirably suited for our purposes, for it has large, cool rooms and smaller outbuildings, one of which was used for a photographic house: while around the fort was a level inclosure surrounded by an embankment and moat, and still further by a system of barb-wire defences, which thoroughly protected us not only from hostile but friendly invasion. Our apparatus arrived in perfect order and was transported from the railroad station to the fort by the aid of a company of prisoners.

While walking with Mr. Derx, and seeing a company of the prisoners go by carrying a load of our instruments, I asked him what they had done which led to their finding themselves in this situation. "Oh," said he, very coolly, "some have murdered, others stolen, and the like."

Our stay at Solok passed quickly by, the days being spent in arranging the apparatus and in drilling ourselves in its use, so that we found but little time to go about to view the other camps or to see the—to us—strange sights which the country afforded. However, partly through exchanges and partly through our own efforts, we all of us secured a more or less complete record of our trip and stay, in the form of photographs, two of which are here reproduced. (Plate V.)

Our chief anxiety throughout our preparations was in regard to the weather, and for the first two or three weeks we were under great despondency, for the days were cloudy almost without exception, and at the hour when the eclipse would be total there was scarcely a day in April when the observations would have been successful. With May, however, our hopes were raised, for while the days were scarcely ever fair throughout, yet during the hour of totality, according to Professor Barnard's count, about two-thirds of the days in May would have been successful eclipse days. Cloudy nights, however, made it very difficult to adjust the apparatus, but by taking advantage of what slight opportunities occurred we were able to get plenty of focus plates by means of which we were assured that the apparatus was in good working order.

On May 17 the sky was overcast and it rained heavily, but we hoped for better weather for the 18th, thinking that so severe a storm meant a speedy clearing, and sure enough on the morning of the 18th the sun broke through the clouds shortly after his rising, and the sky became of a clearness which we never experienced during all our stay there. This continued until after 10 o'clock, when thin, hazy clouds began to form slowly, leaving a perfectly clear belt about the horizon. The first contact came with no very prejudicial degree of cloudiness, but after that it grew steadily thicker, leaving still a clear belt around the horizon, and when the crucial moments of totality occurred the position of the sun could but indistinctly be discerned. Glimpses of the inner corona and prominences could be seen, with the planets Venus and Mercury, but all more like a lantern shining through a thick fog than like anything fit for astronomical observations. It seemed wholly useless to go through the programme; yet, for the sake of having something to show that we had been at an eclipse, we exposed all the intra-mercurial planet plates; but I omitted the bolometric observations wholly, as they could not possibly lead to trustworthy results. I was struck with the amount of the general illumination. The belt of totality was 150 miles wide and we were within less than 30 miles of its center, so that there was a total eclipse belt of nearly 50 miles outside of us, and I had expected a degree of darkness comparable almost with night, but was astonished to perceive that in mid-totality the day was no darker than it often is during a heavy fall of rain.

We were a sorry party after the eclipse as we watched the sky again clear and give us what we had so longed for before—a fine afternoon and night. Professor Barnard, especially, was almost broken hearted, for no one had an apparatus so absolutely perfect for its use as he, and no one had drilled himself to such a state of dexterity as he, and no one, I suppose, will ever obtain an eclipse photograph which will surpass what he would with clear sky have obtained with his long exposure on the 40-inch square plate. To make his discouragement still

more complete, though the night of May 18 was, as I have said, generally fine, yet when he tried as a last attempt to make a long exposure on the rifts in the southern Milky Way, the very regions he wished most to get became covered with a slight degree of fog which spoiled the definition.

The other parties on the island all fared better than we; but only one, the branch of the Naval Observatory expedition which was located at Fort de Kock, close to the northern edge of the shadow, had perfect seeing. There excellent photographs of the corona and prominences were secured with the 40-foot instrument, under Mr. Peters's charge, and spectroscopic results of value were obtained with the grating in the hands of Dr. Humphreys. Dr. Mitchell, at Sawah Loento, was successful in spite of clouds. He secured a fine photograph of the "flash spectrum" at third contact, which gives much information in regard to the sun's atmosphere. The large Dutch party had but very unsatisfactory results, as the cloudiness was almost equal to that at Solok. The main portion of the English expedition, occupying a small island just off the west coast of Sumatra, had, though not a cloudless, yet a not very cloudy sky, and obtained excellent results, of which a short account has lately appeared.

Mr. Perrine, of the Lick Observatory, was pretty successful, considering that he also observed through a very considerable cloudiness, though not equal to that at Solok. His intramercurial planet apparatus revealed possibly thirty or forty stars, where it would have shown perhaps a thousand had the sky been clear; but with his direct photographs and with his spectroscopic work he was much more successful. In a preliminary report from the Lick Observatory it appears that he has obtained good photographs of the coronal spectrum extending to considerable distances each side of the sun, and taken with slit spectroscopes with the slit both tangential and radial to the sun's limb.

In each of these the outer but not the inner corona was shown to have faint Fraunhofer absorption lines in the spectrum, giving, in other words, a reflected solar spectrum, thus proving that a portion at least of the coronal light is reflected from particles. His spectrum photographs, however, show in addition that the major part of the coronal light is probably not reflected, and he attributes it to the incandescence of particles heated by their proximity to the sun. This view, some readers may recall, would be in contradiction to that tentatively advanced from considerations of the bolometric experiments of the Smithsonian Institution at Wadesboro, North Carolina, in 1900, which yielded the inference that the inner corona was relatively a cool source of light assimilable to the glow discharge or to the aurora. I can not altogether understand why it is that Mr. Perrine so positively pronounces the radiation of the inner corona that of an incandescent body rather than that of an electrical discharge or something of a similar



nature, for either would give a continuous spectrum such as he observed. Yet he may have additional evidence, of which I am not aware, in support of this conclusion.

Mr. Perrine has noted the very interesting fact that a certain disturbed region of the corona fell directly over the only sun spot which appeared on the sun within a week or more of the eclipse.

After the eclipse was over we spent the days in packing the instruments, the nights in developing the photographs, and were ready to leave the island by May 28. On the night before our departure Mr. Veth, the United States consular agent, as a last proof of his great kindness, gave a reception to the American and English astronomers and naval officers. This function was extremely enjoyable and was participated in by the officials of the Dutch Government and by the society of Padang, and gave us a feeling that however inhospitable to astronomers could be the climate of Sumatra, yet the kindness of its people went far to atone for it.

#### 6. THE NEW STAR IN PERSEUS.

The greatest interest, both among astronomers and the public, was excited by the announcement of the discovery on February 21, 1901, at 14 hours 40 minutes Greenwich mean time, by Dr. T. D. Anderson, of Edinburgh, Scotland, of a new star in Perseus. This star at the time of its discovery was of the 2.7 magnitude and shone with a bluish white light. It rapidly increased in brightness until on February 23 it reached the 0.0 magnitude, and was then brighter than any fixed star in the heavens with the exception of Sirius and Canopus. An immediate search on the plates taken at the Harvard College Observatory showed that on February 2, 6, 8, 18, and 19, 1901—that is to say, up to within two days of the star's discovery by Dr. Anderson—there was no object there as bright as the 10.5 magnitude.

The duration of extreme brightness of Nova Persei was but temporary, for on reaching its maximum, on February 23, it immediately commenced to decline, and by February 28 had reached the second magnitude, when, after a slight increase in brightness, it again declined nearly continuously until March 18, when it had reached the fifth magnitude. Then began a series of great fluctuations of a somewhat periodic nature, with maxima about two days apart, so that, for instance, on the 19th of March the star was of the 6.5 magnitude, while on the 21st it was of the 4.7 magnitude, a variation of nearly 600 per cent. These fluctuations continued with more or less regularity, though with a gradually increasing interval between them, until the middle of the summer, when the brightness became fairly steady at the sixth to seventh magnitude, and since then there have been no very considerable alterations. The illustration (Plate VI) taken from

Popular Astronomy, November, 1901, shows the history of the brightness of the star up to the last of April.

Immediately after its discovery the spectrum of Nova Persei was thoroughly studied both by photography and visual observations. When first found its spectrum was almost perfectly continuous, but a close examination revealed a few delicate dark Fraunhofer lines in the green, so that at that time the spectrum was, though feebly developed, yet of the so-called Orion type, and very unlike that of the other new stars which had heretofore been observed, and of which bright lines are the most conspicuous feature. By February 24 the spectrum showed a remarkable change, being now traversed by numerous dark and bright bands and closely resembling that of the famous Nova Aurigæ (an earlier discovery of Dr. Anderson), so that the star now became entirely similar to other new stars. This type of spectrum continued with only moderate variations until March 19, when there appears to have been a peculiar change in the spectrum. No dark lines were present on that date except a few faint lines due to the partial reversal of the bright bands, but the continuous spectrum was almost invisible. On March 23, however, the continuous spectrum had reappeared with narrow dark lines, and on March 27 and afterwards there was a strong continuous spectrum. During the month of April the spectrum departed from the recognized type in many particulars, and occasionally the continuous part was absent, only separated bright bands remaining. There appears then to have been two types of spectrum during the months of March, April, and May, while the brightness of the star was so variable, and it is interesting to note that on the dates when the spectrum was peculiar—that is to say, not similar to the spectra of the other new stars—the brightness of Nova Persei was at a minimum.

But not only has Nova Persei made a characteristic record for itself as regards the variations of its brightness and of its spectrum, but in August it presented a new and still more remarkable feature. Reports came from France that a faint nebula had been photographed about the star, and while this was at first contradicted and ascribed to optical defects in the apparatus, yet it was not long before the discovery was thoroughly confirmed, and a faint circular nebula was photographed surrounding the planet like a halo. Nor was this all, for there were in the nebula several condensations of nebulosity, which were sufficiently marked to have definite positions.

On November 7 and 8 this nebula was photographed at the Lick Observatory, and upon comparing the position of the condensations of which I have spoken with the photograph obtained on September 20, at the Yerkes Observatory, it was found that these condensations had actually moved at a rate which, if continued for a year, would amount to 11 minutes of arc in the heavens. The reader will find evidence

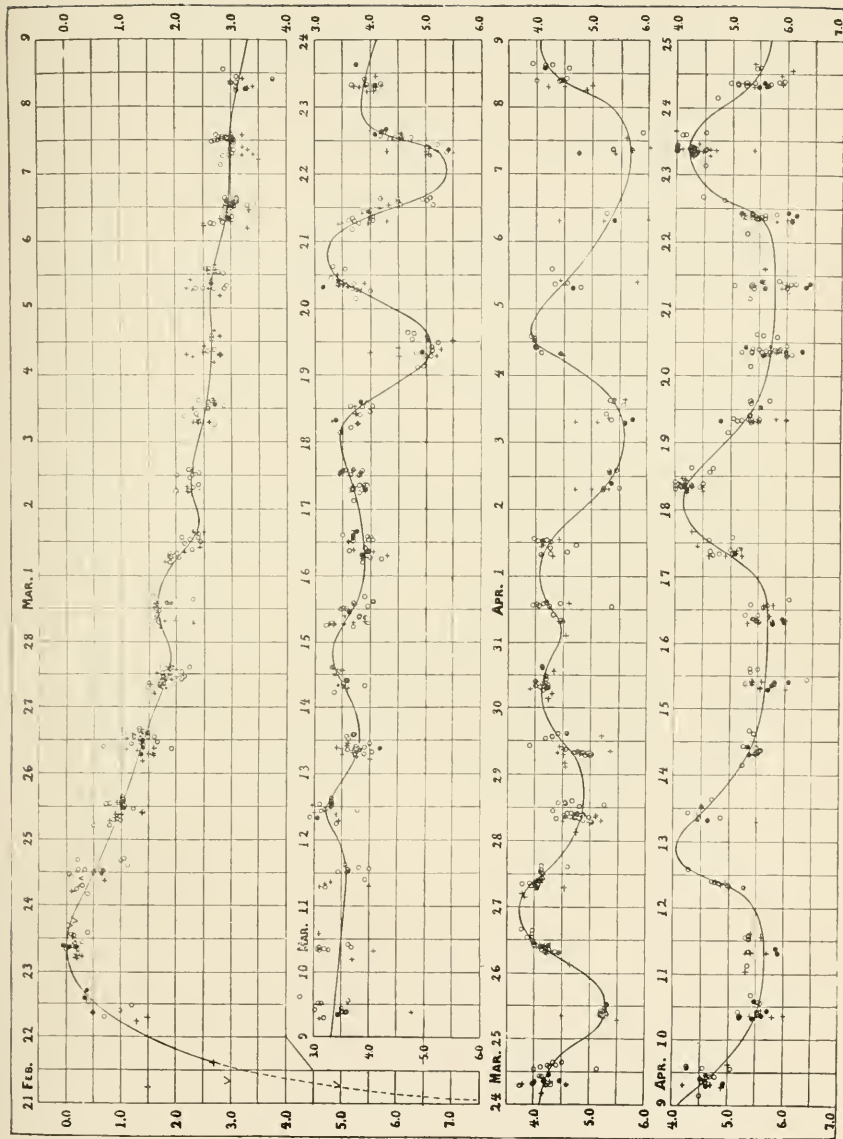

THE LIGHT CURVE OF NOVA PERSEI FEBRUARY 21 TO APRIL 24, 1901.

Reproduced by permission of H. C. Wilson from Popular Astronomy, Northfield, Minn., November 1901.



of this displacement in Plate III, already referred to. Later photographs show a continuation of the rapid expansion of the nebula. The astonishing magnitude of this motion becomes more appreciated when it is said that the greatest displacement or proper motion of a star so far observed in the whole universe is less than 9 seconds per annum, or less than one-seventieth part of the rate of motion of the nebula surrounding Nova Persei. This great disparity has led some to think it is the propagation of light and not of material which is made apparent.

What further of interest Nova Persei has in store for us we can not foretell, but up to the present time its appearance and subsequent history have deserved to take rank as the foremost astronomical event of the year.



## A MODEL OF NATURE.<sup>a</sup>

By ARTHUR W. RUCKER, M. A., LL.D.

\* \* \* Two years ago Sir Michael Foster dealt with the work of the century as a whole. Last year Sir William Turner discussed in greater detail the growth of a single branch of science. A third and humbler task remains, viz, to fix our attention on some of the hypotheses and assumptions on which the fabric of modern theoretical science has been built, and to inquire whether the foundations have been so "well and truly" laid that they may be trusted to sustain the mighty superstructure which is being raised upon them.

The moment is opportune. The three chief conceptions which for many years have dominated physical as distinct from biological science have been the theories of the existence of atoms, of the mechanical nature of heat, and of the existence of the ether.

Dalton's atomic theory was first given to the world by a Glasgow professor—Thomas Thomson—in the year 1807, Dalton having communicated it to him in 1804. Rumford's and Davy's experiments on the nature of heat were published in 1798 and 1799, respectively; and the celebrated Bakerian lecture, in which Thomas Young established the undulatory theory by explaining the interference of light, appeared in the *Philosophical Transactions* in 1801. The keynotes of the physical science of the nineteenth century were thus struck as the century began by four of our fellow-countrymen, one of whom—Sir Benjamin Thompson, Count Rumford—preferred exile from the land of his birth to the loss of his birthright as a British citizen.

### DOUBTS AS TO SCIENTIFIC THEORIES.

It is well known that of late doubts have arisen as to whether the atomic theory, with which the mechanical theory of heat is closely bound up, and the theory of the existence of an ether have not served their purpose, and whether the time has not come to reconsider them.

The facts that Professor Poincaré, addressing a congress of physicists in Paris, and Professor Poynting, addressing the physical section

<sup>a</sup>Address of the President of the British Association for the Advancement of Science, at the Glasgow meeting, 1901. Reprinted from Report of the British Association, 1901.

of the association, have recently discussed the true meaning of our scientific methods of interpretation; that Dr. James Ward has lately delivered an attack of great power on many positions which eminent scientific men have occupied; and that the approaching end of the nineteenth century led Professor Hæckel to define in a more popular manner his own very definite views as to the solution of the "Riddle of the Universe," are, perhaps, a sufficient justification of an attempt to lay before you the difficulties which surround some of these questions.

To keep the discussion within reasonable limits, I shall illustrate the principles under review by means of the atomic theory, with comparatively little reference to the æther, and we may also at first confine our attention to inanimate objects.

#### THE CONSTRUCTION OF A MODEL OF NATURE.

A natural philosopher, to use the old phrase, even if only possessed of a most superficial knowledge, would attempt to bring some order into the results of his observation of nature by grouping together statements with regard to phenomena which are obviously related. The aim of modern science goes far beyond this. It not only shows that many phenomena are related which at first sight have little or nothing in common, but, in so doing, also attempts to explain the relationship.

Without spending time on a discussion of the meaning of the word "explanation," it is sufficient to say that our efforts to establish relationships between phenomena often take the form of attempting to prove that if a limited number of assumptions are granted as to the constitution of matter, or as to the existence of quasi material entities, such as caloric, electricity, and the ether, a wide range of observed facts falls into order as a necessary consequence of the assumptions. The question at issue is whether the hypotheses which are at the base of the scientific theories now most generally accepted are to be regarded as accurate descriptions of the constitution of the universe around us, or merely as convenient fictions.

Convenient fictions be it observed, for even if they are fictions they are not useless. From the practical point of view it is a matter of secondary importance whether our theories and assumptions are correct, if only they guide us to results which are in accord with facts. The whole fabric of scientific theory may be regarded merely as a gigantic "aid to memory;" as a means for producing apparent order out of disorder by codifying the observed facts and laws in accordance with an artificial system, and thus arranging our knowledge under a comparatively small number of heads. The simplification introduced by a scheme which, however imperfect it may be, enables us to argue from a few first principles, makes theories of practical use. By means



of them we can foresee the results of combinations of causes which would otherwise elude us. We can predict future events, and can even attempt to argue back from the present to the unknown past.

But it is possible that these advantages might be attained by means of axioms, assumptions, and theories based on very false ideas. A person who thought that a river was really a streak of blue paint might learn as much about its direction from a map as one who knew it as it is. It is thus conceivable that we might be able, not indeed to construct, but to imagine, something more than a mere map or diagram, something which might even be called a working model of inanimate objects, which was, nevertheless, very unlike the realities of nature. Of course the agreement between the action of the model and the behavior of the things it was designed to represent would probably be imperfect, unless the one were a facsimile of the other; but it is conceivable that the correlation of natural phenomena could be imitated, with a large measure of success, by means of an imaginary machine which shared with a map or diagram the characteristic that it was in many ways unlike the things it represented, but might be compared to a model in that the behavior of the things represented could be predicted from that of the corresponding parts of the machine.

We might even go a step farther. If the laws of the working of the model could be expressed by abstractions, as, for example, by mathematical formulæ, then, when the formulæ were obtained, the model might be discarded, as probably unlike that which it was made to imitate, as a mere aid in the construction of equations, to be thrown aside when the perfect structure of mathematical symbols was erected.

If this course were adopted we should have given up the attempt to know more of the nature of the objects which surround us than can be gained by direct observation, but might nevertheless have learned how these objects would behave under given circumstances.

We should have abandoned the hope of a physical explanation of the properties of inanimate nature, but should have secured a mathematical description of her operations.

There is no doubt that this is the easiest path to follow. Criticism is avoided if we admit from the first that we can not go below the surface; can not know anything about the constitution of material bodies, but must be content with formulating a description of their behavior by means of laws of nature expressed by equations.

But if this is to be the end of the study of nature, it is evident that the construction of the model is not an essential part of the process. The model is used merely as an aid to thinking, and if the relations of phenomena can be investigated without it, so much the better. The highest form of theory—it may be said—the widest kind of generalization, is that which has given up the attempt to form clear mental pictures of the constitution of matter, which expresses the facts and

the laws by language and symbols which lead to results that are true, whatever be our view as to the real nature of the objects with which we deal. From this point of view the atomic theory becomes not so much false as unnecessary. It may be regarded as an attempt to give an unnatural precision to ideas which are and must be vague.

Thus, when Rumford found that the mere friction of metals produced heat in unlimited quantity, and argued that heat was therefore a mode of motion, he formed a clear mental picture of what he believed to be occurring. But his experiments may be quoted as proving only that energy can be supplied to a body in indefinite quantity, and when supplied by doing work against friction it appears in the form of heat.

By using this phraseology we exchange a vivid conception of moving atoms for a colorless statement as to heat energy, the real nature of which we do not attempt to define; and methods which thus evade the problem of the nature of the things which the symbols in our equations represent have been prosecuted with striking success, at all events, within the range of a limited class of phenomena. A great school of chemists, building upon the thermodynamics of Willard Gibbs and the intuition of Van't Hoff, have shown with wonderful skill that, if a sufficient number of the data of experiment are assumed, it is possible, by the aid of thermodynamics, to trace the form of the relations between many physical and chemical phenomena without the help of the atomic theory.

But this method deals only with matter as our coarse senses know it; it does not pretend to penetrate beneath the surface.

It is therefore with the greatest respect for its authors, and with a full recognition of the enormous power of the weapons employed, that I venture to assert that the exposition of such a system of tactics can not be regarded as the last word of science in the struggle for the truth.

Whether we grapple with them or whether we shirk them; however much or however little we can accomplish without answering them, the questions still force themselves upon us: Is matter what it seems to be? Is interplanetary space full or empty? Can we argue back from the direct impressions of our senses to things which we can not directly perceive—from the phenomena displayed by matter to the constitution of matter itself?

It is these questions which we are discussing to-night, and we may therefore, as far as the present address is concerned, put aside, once for all, methods of scientific exposition in which an attempt to form a mental picture of the constitution of matter is practically abandoned, and devote ourselves to the inquiries whether the effort to form such a picture is legitimate, and whether we have any reason to believe that the sketch which science has already drawn is to some extent a copy, and not a mere diagram, of the truth.

## SUCCESSIVE STEPS IN THE ANALYSIS OF MATTER.

In dealing, then, with the question of the constitution of matter and the possibility of representing it accurately, we may grant at once that the ultimate nature of things is, and must remain, unknown; but it does not follow that immediately below the complexities of the superficial phenomena which affect our senses there may not be a simpler machinery of the existence of which we can obtain evidence, indirect, indeed, but conclusive.

The fact that the apparent unity which we call the atmosphere can be resolved into a number of different gases is admitted; though the ultimate nature of oxygen, nitrogen, argon, carbonic acid, and water vapor is as unintelligible as that of air as a whole, so that the analysis of air may be said to have substituted many incomprehensibles for one.

Nobody, however, looks at the question from this point of view. It is recognized that an investigation into the proximate constitution of things may be useful and successful, even if their ultimate nature is beyond our ken.

Nor need the analysis stop at the first step. Water vapor and carbonic acid, themselves constituents of the atmosphere, are in turn resolved into their elements, hydrogen, oxygen, and carbon, which, without a formal discussion of the criteria of reality, we may safely say are as real as air itself.

Now, at what point must this analysis stop if we are to avoid crossing the boundary between fact and fiction? Is there any fundamental difference between resolving air into a mixture of gases and resolving an elementary gas into a mixture of atoms and ether?

There are those who cry halt at the point at which we divide a gas into molecules, and their first objection seems to be that molecules and atoms can not be directly perceived, can not be seen or handled, and are mere conceptions, which have their uses, but can not be regarded as realities.

It is easiest to reply to this objection by an illustration.

The rings of Saturn appear to be continuous masses separated by circular rifts. This is the phenomenon which is observed through a telescope. By no known means can we ever approach or handle the rings; yet everybody who understands the evidence now believes that they are not what they appear to be, but consist of minute moonlets, closely packed, indeed, but separate the one from the other.

In the first place, Maxwell proved mathematically that if a Saturnian ring were a continuous solid or fluid mass it would be unstable and would necessarily break into fragments. In the next place, if it were possible for the ring to revolve like a solid body, the inmost parts would move slowest, while a satellite moves faster the nearer it is to a planet. Now, spectroscopic observation, based on the beautiful

method of Sir W. Huggins, shows not only that the inner portions of the ring move the more rapidly, but that the actual velocities of the outer and inner edges are in close accord with the theoretical velocities of satellites at like distances from the planet.

This and a hundred similar cases prove that it is possible to obtain convincing evidence of the constitution of bodies between whose separate parts we can not directly distinguish, and I take it that a physicist who believes in the reality of atoms thinks that he has as good reason for dividing an apparently continuous gas into molecules as he has for dividing the apparently continuous Saturnian rings into satellites. If he is wrong it is not the fact that molecules and satellites alike can not be handled and can not be seen as individuals that constitutes the difference between the two cases.

It may, however, be urged that atoms and the ether are alleged to have properties different from those of matter in bulk, of which alone our senses take direct cognizance, and that therefore it is impossible to prove their existence by evidence of the same eogeneity as that which may prove the existence of a newly discovered variety of matter or of a portion of matter too small or too distant to be seen.

This point is so important that it requires full discussion, but in dealing with it, it is necessary to distinguish carefully between the validity of the arguments which support the earlier and more fundamental propositions of the theory and the evidence brought forward to justify mere speculative applications of its doctrines which might be abandoned without discarding the theory itself. The proof of the theory must be carried out step by step.

The first step is concerned wholly with some of the most general properties of matter, and consists in the proof that those properties are either absolutely unintelligible, or that, in the case of matter of all kinds, we are subject to an illusion similar to that, the results of which we admit in the case of Saturn's rings, clouds, smoke, and a number of similar instances. The believer in the atomic theory asserts that matter exists in a particular state; that it consists of parts which are separate and distinct the one from the other, and as such are capable of independent movements.

Up to this point no question arises as to whether the separate parts are, like grains of sand, mere fragments of matter, or whether, though they are the bricks of which matter is built, they have, as individuals, properties different from those of masses of matter large enough to be directly perceived. If they are mere fragments of ordinary matter, they can not be used as aids in explaining those qualities of matter which they themselves share.

We can not explain things by things themselves. If it be true that the properties of matter are the product of an underlying machinery, that machinery can not itself have the properties which it produces,

and must, to that extent, at all events, differ from matter in bulk as it is directly presented to the senses.

If, however, we can succeed in showing that if the separate parts have a limited number of properties (different, it may be, from those of matter in bulk), the many and complicated properties of matter can, to a considerable extent, be explained as consequences of the constitution of these separate parts: we shall have succeeded in establishing, with regard to quantitative properties, a simplification similar to that which the chemist has established with regard to varieties of matter. The many will have been reduced to the few.

The proofs of the physical reality of the entities discovered by means of the two analyses must necessarily be different. The chemist can actually produce the elementary constituents into which he has resolved a compound mass. No physicist or chemist can produce a single atom separated from all its fellows and show that it possesses the elementary qualities he assigns to it. The cogency of the evidence for any suggested constitution of atoms must vary with the number of facts which the hypothesis that they possess that constitution explains.

Let us take, then, two steps in their proper order, and inquire, first, whether there is valid ground for believing that all matter is made up of discrete parts; and, secondly, whether we can have any knowledge of the constitution or properties which those parts possess.

#### THE COARSE-GRAINEDNESS OF MATTER.

Matter in bulk appears to be continuous. Such substances as water or air appear to the ordinary observer to be perfectly uniform in all their properties and qualities, in all their parts.

The hasty conclusion that these bodies are really uniform is, nevertheless, unthinkable.

In the first place the phenomena of diffusion afford conclusive proof that matter when apparently quiescent is in fact in a state of internal commotion. I need not recapitulate the familiar evidence to prove that gases and many liquids when placed in communication interpenetrate or diffuse into each other; or that air, in contact with a surface of water, gradually becomes laden with water vapor, while the atmospheric gases in turn mingle with the water. Such phenomena are not exhibited by liquids and gases alone, nor by solids at high temperatures only. Sir W. Roberts-Austen has placed pieces of gold and lead in contact at a temperature of 18° C. After four years the gold had traveled into the lead to such an extent that not only were the two metals united, but, on analysis, appreciable quantities of the gold were detected even at a distance of more than 5 millimeters from the common surface, while within a distance of three-quarters of a millimeter from the surface gold had penetrated into the lead to the extent of

1 ounce 6 pennyweights per ton, an amount which could have been profitably extracted.

Whether it is or is not possible to devise any other intelligible account of the cause of such phenomena, it is certain that a simple and adequate explanation is found in the hypothesis that matter consists of discrete parts in a state of motion, which can penetrate into the spaces between the corresponding parts of the surrounding bodies.

The hypothesis thus framed is also the one which affords a rational explanation of other simple and well-known facts. If matter is regarded as a continuous medium the phenomena of expansion are unintelligible. There is, apparently, no limit to the expansion of matter, or, to fix our attention on one kind of matter, let us say to the expansion of gas; but it is inconceivable that a continuous material which fills or is present in every part of a given space could also be present in every part of a space a million times as great. Such a statement might be made of a mathematical abstraction; it can not be true of any real substance or thing. If, however, matter consists of discrete particles, separated from each other either by empty space or by something different from themselves, we can at once understand that expansion and contraction may be nothing more than the mutual separation or approach of these particles.

Again, no clear mental picture can be formed of the phenomena of heat unless we suppose that heat is a mode of motion. In the words of Rumford, "it is extremely difficult, if not quite impossible, to form any distinct idea of anything capable of being excited and communicated in the manner the heat was excited and communicated in [his] experiment [on friction] except it be motion."<sup>a</sup> And if heat be motion, there can be no doubt that it is the fundamental particles of matter which are moving. For the motion is not visible, is not motion of the body as a whole, while diffusion, which is a movement of matter, goes on more quickly as the temperature rises, thereby proving that the internal motions have become more rapid, which is exactly the result which would follow if these were the movements which constitute sensible heat.

Combining, then, the phenomena of diffusion, expansion, and heat, it is not too much to say that no hypotheses which make them intelligible have ever been framed other than those which are at the basis of the atomic theory.

Many other considerations also point to the same conclusion. Many years ago Lord Kelvin gave independent arguments, based on the properties of gases, on the constitutions of the surfaces of liquids, and on the electric properties of metals, all of which indicate that matter is, to use his own phrase, coarse-grained—that it is not identical in

<sup>a</sup> Phil. Trans., 1789, p. 99.

constitution throughout, but that adjacent minute parts are distinguishable from each other by being either of different natures or in different states.

And here it is necessary to insist that all these fundamental proofs are independent of the nature of the particles or granules into which matter must be divided.

The particles, for instance, need not be different in kind from the medium which surrounds and separates them. It would suffice if they were what may be called singular parts of the medium itself, differing from the rest only in some peculiar state of internal motion or of distortion, or by being in some other way earmarked as distinct individuals. The view that the constitution of matter is atomic may and does receive support from theories in which definite assumptions are made as to the constitution of the atoms, but when, as is often the case, these assumptions introduce new and more recondite difficulties, it must be remembered that the fundamental hypothesis—that matter consists of discrete parts, capable of independent motions—is forced upon us by facts and arguments which are altogether independent of what the nature and properties of these separate parts may be.

As a matter of history the two theories, which are not by any means mutually exclusive, that atoms are particles which can be treated as distinct in kind from the medium which surrounds them, and that they are parts of that medium existing in a special state, have both played a large part in the theoretical development of the atomic hypothesis. The atoms of Waterston, Clausius, and Maxwell were particles. The vortex-atoms of Lord Kelvin, and the strain-atoms (if I may call them so) suggested by Mr. Larmor, are states of a primary medium which constitutes a physical connection between them, and through which their mutual actions arise and are transmitted.

#### PROPERTIES OF THE BASIS OF MATTER.

It is easy to show that, whichever alternative be adopted, we are dealing with something, whether we consider it under the guise of separate particles or of differentiated portions of the medium, which has properties different from those of matter in bulk.

For if the basis of matter had the same constitution as matter, the irregular heat movements could hardly be maintained either against the viscosity of the medium or the frittering away of energy of motion which would occur during the collisions between the particles. Thus, even in the case in which a hot body is prevented from losing heat to surrounding objects, its sensible heat should spontaneously decay by a process of self-cooling. No such phenomenon is known, and though on this, as on all other points, the limits of our knowledge are fixed by the uncertainty of experiment, we are compelled to admit that, to all appearance, the fundamental medium, if it exists, is

unlike a material medium, in that it is nonviscous; and that the particles, if they exist, are so constituted that energy is not frittered away when they collide. In either case we are dealing with something different from matter itself in the sense that, though it is the basis of matter, it is not identical in all its properties with matter.

The idea therefore that entities exist possessing properties different from those of matter in bulk is not introduced at the end of a long and recondite investigation to explain facts with which none but experts are acquainted. It is forced upon us at the very threshold of our study of nature. Either the properties of matter in bulk can not be referred to any simpler structure, or that simpler structure must have properties different from those of matter in bulk as we directly knew it—properties which can only be inferred from the results which they produce.

No *à priori* argument against the possibility of our discovering the existence of quasi-material substances, which are nevertheless different from matter, can prove the negative proposition that such substances can not exist. It is not a self-evident truth that no substance other than ordinary matter can have an existence as real as that of matter itself. It is not axiomatic that matter can not be composed of parts whose properties are different from those of the whole. To assert that even if such substances and such parts exist no evidence, however cogent, could convince us of their existence is to beg the whole question at issue; to decide the cause before it has been heard.

We must therefore adhere to the standpoint adopted by most scientific men, viz, that the question of the existence of ultraphysical entities, such as atoms and the ether, is to be settled by the evidence, and must not be ruled out as inadmissible on *à priori* grounds.

On the other hand, it is impossible to deny that, if the mere entry on the search for the concealed causes of physical phenomena is not a trespass on ground we have no right to explore, it is at all events the beginning of a dangerous journey.

The wraiths of phlogiston, caloric, luminiferous corpuseles and a crowd of other phantoms haunt the investigator, and as the grim host vanishes into nothingness he can not but wonder if his own conceptions of atoms and of the ether

shall dissolve,  
And, like this insubstantial pageant faded,  
Leave not a wreck behind.

But though science, like Bunyan's hero, has sometimes had to pass through the "Valley of Humiliation," the specters which meet it there are not really dangerous if they are boldly faced. The facts that mistakes have been made, that theories have been propounded, and for a time accepted, which later investigations have disproved, do not



necessarily discredit the method adopted. In scientific theories, as in the world around us, there is a survival of the fittest, and Dr. James Ward's unsympathetic account of the blunders of those whose work after all has shed glory on the nineteenth century, might *mutatis mutandis* stand for a description of the history of the advance of civilization. "The story of the progress so far," he tells us, "is briefly this: Divergence between theory and fact one part of the way, the wreckage of abandoned fictions for the rest, with an unattainable goal of phenomenal nihilism and ultraphysical mechanism beyond."<sup>a</sup>

"The path of progress," says Prof. Karl Pearson, "is strewn with the wreck of nations. Traces are everywhere to be seen of the hecatombs of inferior races and of victims who found not the narrow way to the greater perfection. Yet these dead peoples are in very truth the stepping-stones on which mankind has arisen to the higher intellectual and deeper emotional life of to-day."<sup>b</sup>

It is only necessary to add that the progress of society is directed toward an unattainable goal of universal contentment to make the parallel complete.

And so, in the one case as in the other, we may leave "the dead to bury the dead." The question before us is not whether we too may not be trusting to false ideas, erroneous experiments, evanescent theories. No doubt we are; but, without making an insolent claim to be better than our fathers, we may fairly contend that, amid much that is uncertain and temporary, some of the fundamental conceptions, the root ideas of science, are so grounded on reason and fact that we can not but regard them as an aspect of the very truth.

Enough has, perhaps, now been said on this point for my immediate purpose. The argument as to the constitution of matter could be developed further in the manner I have hitherto adopted, viz, by series of propositions, the proof of each of which is based upon a few crucial phenomena. In particular, if matter is divided into moving granules or particles, the phenomenon of cohesion proves that there must be mutual actions between them analogous to those which take place between large masses of matter, and which we ascribe to force, thereby indicating the regular, unvarying operation of active machinery which we have not yet the means of adequately understanding. For the moment, I do not wish to extend the line of reasoning that has been followed. My main object is to show that the notion of the existence of ultraphysical entities and the leading outlines of the atomic theory are forced upon us at the beginning of our study of nature, not only by *à priori* considerations, but in the attempt to comprehend the results of even the simplest observation. These outlines can not be effaced by the difficulties which undoubtedly arise in filling

<sup>a</sup> James Ward, *Naturalism and Agnosticism*, Vol. I, p. 153.

<sup>b</sup> Karl Pearson, *National Life from the Standpoint of Science*, p. 62.

up the picture. The cogency of the proof that matter is coarse grained is in no way affected by the fact that we have grave doubts as to the nature of granules. Nay, it is of the first importance to recognize that, though the fundamental assumptions of the atomic theory receive overwhelming support from a number of more detailed arguments, they are themselves almost of the nature of axioms, in that the simplest phenomena are unintelligible if they are abandoned.

#### THE RANGE OF THE ATOMIC THEORY.

It would be most unfair, however, to the atomic theory to represent it as depending on one line of reasoning only, or to treat its evidence as bounded by the very general propositions I have discussed.

It is true that as the range of the theory is extended the fundamental conception that matter is granular must be expanded and filled in by supplementary hypotheses as to the constitution of granules. It may also be admitted that no complete or wholly satisfactory description of that constitution can as yet be given; that perfection has not yet been attained here or in any other branch of science; but the number of facts which can be accounted for by the theory is very large compared with the number of additional hypotheses which are introduced; and the cumulative weight of the additional evidence obtained by the study of details is such as to add greatly to the strength of the conviction that, in its leading outlines, the theory is true.

It was originally suggested by the facts of chemistry, and though, as we have seen, a school of chemists now thrusts it into the background, it is none the less true, in the words of Dr. Thorpe, that "every great advance in chemical knowledge during the last ninety years finds its interpretation in [Dalton's] theory."<sup>a</sup>

The principal mechanical and thermal properties of gases have been explained and in a large part discovered by the aid of the atomic theory, and though there are outstanding difficulties, they are, for the most part, related to the nature of the atoms and molecules, and do not affect the question as to whether they exist.

The fact that different kinds of light all travel at the same speed in interplanetary space, while they move at different rates in matter, is explained if matter is coarse grained. But to attempt to sum up all this evidence would be to recite a text-book on physics. It must suffice to say that it is enormous in extent and varied in character, and that the atomic theory imparts a unity to all the physical sciences which has been attained in no other way.

I must, however, give a couple of instances of the wonderful success which has been achieved in the explanation of physical phenomena by the theory we are considering, and I select them because they are in harmony with the line of argument I have been pursuing.

<sup>a</sup> Thorpe, *Essays on Historical Chemistry*, 1894, p. 368.

When a piece of iron is magnetized its behavior is different according as the magnetic force applied to it is weak, moderate, or strong. When a certain limit is passed the iron behaves as a nonmagnetic substance to all further addition of magnetic force. With strong forces it does and with very weak forces it does not remain magnetized when the force ceases to act. Professor Ewing has imitated all the minute details of these complicated properties by an arrangement of small isolated compass needles to represent the molecules. It may fairly be said that as far as this particular set of phenomena is concerned, a most instructive working model based on the molecular theory has not only been imagined but constructed.

The next illustration is no less striking. We may liken a crowd of molecules to a fog; but while the fog is admitted by everybody to be made up of separate globules of water, the critics of scientific method are sometimes apt to regard the molecules as mere fictions of the imagination. If, however, we could throw the molecules of a highly rarefied gas into such a state that vapor condensed on them, so that each became the center of a water drop, till the host of invisible molecules was, as it were, magnified by accretion into a visible mist, surely no stronger proof of their reality could be desired. Yet there is every reason to believe that something very like this has been accomplished by Mr. C. T. R. Wilson and Prof. J. J. Thomson.

It is known that it is comparatively difficult to produce a fog in damp air if the mixture consists of air and water vapor alone. The presence of particles of very fine dust facilitates the process. It is evident that the vapor condenses on the dust particles, and that a nucleus of some kind is necessary on which each drop may form. But electrified particles also act as nuclei, for if a highly charged body from which electricity is escaping be placed near a steam jet, the steam condenses, and a cloud is also formed in dust-free air more easily than would otherwise be the case if electricity is discharged into it.

Again, according to accepted theory, when a current of electricity flows through a gas some of the atoms are divided into parts which carry positive and negative charges as they move in opposite directions, and unless this breaking up occurs a gas does not conduct electricity. But a gas can be made a conductor merely by allowing the Röntgen rays or the radiation given off by uranium to fall upon it. A careful study of the facts shows that it is probable that some of the atoms have been broken up by the radiation, and that their oppositely electrified parts are scattered among their unaltered fellows. Such a gas is said to be ionized.

Thus by these two distinct lines of argument we come to the conclusions: First, that the presence of electrified particles promotes the formation of mist, and, second, that in an ionized gas such electrified particles are provided by the breaking up of atoms.

The two conclusions will mutually support each other if it can be shown that a mist is easily formed in ionized air. This was tested by Mr. Wilson, who showed that in such air mist is formed as though nuclei were present, and thus in the cloud we have visible evidence of the presence of the divided atoms. If, then, we can not handle the individual molecules we have at least some reason to believe that a method is known of seizing individuals, or parts of individuals, which are in a special state, and of wrapping other matter round them till each one is the center of a discrete particle of a visible fog.

I have purposely chosen this illustration, because the explanation is based on a theory—that of ionization—which is at present subjected to hostile criticism. It assumes that an electrical current is nothing more than the movement of charges of electricity. But magnets placed near to an electric current tend to set themselves at right angles to its direction; a fact on which the construction of telegraphic instruments is based. Hence, if the theory be true, a similar effect ought to be produced by a moving charge of electricity. This experiment was tried many years ago in the laboratory of Helmholtz by Rowland, who caused a charged disk to spin rapidly near a magnet. The result was in accord with the theory; the magnet moved as though acted upon by an electric current. Of late, however, M. Crémieu has investigated the matter afresh, and has obtained results which, according to his interpretation, were inconsistent with that of Rowland.

M. Crémieu's results are already the subject of controversy,<sup>a</sup> and are, I believe, likely to be discussed in the section of physics. This is not the occasion to enter upon a critical discussion of the question at issue, and I refer to it only to point out that though, if M. Crémieu's results were upheld, our views as to electricity would have to be modified, the foundations of the atomic theory would not be shaken.

It is, however, from the theory of ions that the most far-reaching speculations of science have recently received unexpected support. The dream that matter of all kinds will some day be proved to be fundamentally the same has survived many shocks. The opinion is consistent with the great generalization that the properties of elements are a periodic function of their atomic weights. Sir Norman Lockyer has long been a prominent exponent of the view that the spectra of the stars indicate the reduction of our so-called elements to simpler forms, and now Prof. J. J. Thomson believes that we can break off from an atom a part, the mass of which is not more than one-thousandth of the whole, and that these corpuscles, as he has named them, are the carriers of the negative charge in an electric current. If atoms are thus complex, not only is the a priori probability increased that the different structures which we call elements may all be built of

---

<sup>a</sup> See *Phil. Mag.*, July, 1901, p. 144; and *Johns Hopkins University Circulars*, XX, No. 152, May-June, 1901, p. 78.

similar bricks, but the discovery by Lenard that the ease with which the corpuscles penetrate different bodies depends only on the density of the obstacles, and not on their chemical constitution, is held by Professor Thomson to be "a strong confirmation of the view that the atoms of the elementary substances are made up of simpler parts, all of which are alike."<sup>a</sup> On the present occasion, however, we are occupied rather with the foundations than with these ultimate ramifications of the atomic theory; and having shown how wide its range is, I must, to a certain extent, retrace my steps and return to the main line of my argument.

#### THE PROPERTIES OF ATOMS AND MOLECULES.

For if it be granted that the evidence that matter is coarse grained and is formed of separate atoms and molecules is too strong to be resisted, it may still be contended that we can know little or nothing of the sizes and properties of the molecules.

It must be admitted that though the fundamental postulates are always the same, different aspects of the theory, which have not in all cases been successfully combined, have to be developed when it is applied to different problems; but in spite of this there is little doubt but that we have some fairly accurate knowledge of molecular motions and magnitudes.

If a liquid is stretched into a very thin film, such as a soap bubble, we should expect indications of a change in its properties when the thickness of the film is not a very large multiple of the average distance between two neighboring molecules. In 1890, Sohneke<sup>b</sup> detected evidence of such a change in films of average thickness of 106 millionths of a millimeter ( $\mu\mu$ ), and quite recently Rudolph Weber found it in an oil film when the thickness was 115  $\mu\mu$ .<sup>c</sup>

Taking the mean of these numbers and combining the results of different variants of the theory, we may conclude that a film should become unstable and tend to rupture spontaneously somewhere between the thicknesses of 110 and 55  $\mu\mu$ , and Professor Reinold and I found by experiment that this instability is actually exhibited between the thickness of 96 and 45  $\mu\mu$ .<sup>d</sup> There can therefore be little doubt that the first approach to molecular magnitude is signaled when the thickness of a film is somewhat less than 100  $\mu\mu$ , or four millionths of an inch.

Thirteen years ago I had the honor of laying before the Chemical

<sup>a</sup> For the most recent account of this subject, see an article on "Bodies smaller than atoms," by Prof. J. J. Thomson, in the *Popular Science Monthly* (The Science Press), August, 1901. [Reprinted in the present *Smithsonian Report*.]

<sup>b</sup> *Wied. Ann.*, 1890, XL, pp. 345-355.

<sup>c</sup> *Annalen der Physik*, 1901, IV, pp. 706-721.

<sup>d</sup> *Phil. Trans.*, 1893, 184, pp. 505-529.

Society a résumé of what was then known on these subjects,<sup>a</sup> and I must refer to that lecture or to the most recent edition of O. E. Meyer's work on the kinetic theory of gases<sup>b</sup> for the evidence that various independent lines of argument enable us to estimate quantities very much less than four millionths of an inch, which is perhaps from 500 to 1,000 times greater than the magnitude which, in the present state of our knowledge, we can best describe as the diameter of a molecule.

Confining our attention, however, to the larger quantities, I will give one example to show how strong is the cumulative force of the evidence as to our knowledge of the magnitudes of molecular quantities.

We have every reason to believe that though the molecules in a gas frequently collide with each other, yet in the case of the more perfect gases the time occupied in collisions is small compared with that in which each molecule travels undisturbed by its fellows. The average distance traveled between two successive encounters is called the mean free path, and, for the reason just given, the question of the magnitude of this distance can be attacked without any precise knowledge of what a molecule is, or of what happens during an encounter.

Thus the mean free path can be determined, by the aid of the theory, either from the viscosity of the gas or from the thermal conductivity. Using figures given in the latest work on the subject,<sup>c</sup> and dealing with one gas only, as a fair sample of the rest, the lengths of the mean free path of hydrogen, as determined by these two independent methods, differ only by about 3 per cent. Further, the mean of the values which I gave in the lecture already referred to differed only by about 6 per cent from the best modern result, so that no great change has been introduced during the last thirteen years.

It may, however, be argued that these concordant values are all obtained by means of the same theory, and that a common error may affect them all. In particular, some critics have of late been inclined to discredit the atomic theory by pointing out that the strong statements which have sometimes been made as to the equality, among themselves, of atoms or molecules of the same kind may not be justified, as the equality may be that of averages only, and be consistent with a considerable variation in the sizes of individuals.

Allowing this argument more weight than it perhaps deserves, it is easy to show that it can not affect seriously our knowledge of the length of the mean free path.

Prof. George Darwin<sup>d</sup> has handled the problem of a mixture of

---

<sup>a</sup> Chem. Soc. Trans., LIII, March, 1888, pp. 222-262.

<sup>b</sup> Kinetic Theory of Gases, O. E. Meyer, 1899; translated by R. E. Baynes.

<sup>c</sup> Meyer's Kinetic Theory of Gases (see above).

<sup>d</sup> Phil. Trans., 180.

unequal spherical bodies in the particular case in which the sizes are distributed according to the law of errors, which would involve far greater inequalities than can occur among atoms. Without discussing the precise details of his problem, it is sufficient to say that in the case considered by him the length of the main free path is seven-elevenths of what it would be if the particles were equal. Hence, were the inequalities of atoms as great as in this extreme case, the reduction of the mean free path in hydrogen could only be from 185 to 119  $\mu\mu$ ; but they must be far less, and therefore the error, if any, due to this cause could not approach this amount. It is probably inappreciable.

Such examples might be multiplied, but the one I have selected is perhaps sufficient to illustrate my point, viz, that considerable and fairly accurate knowledge can be obtained as to molecular quantities by the aid of theories, the details of which are provisional and are admittedly capable of improvement.

#### IS THE MODEL UNIQUE?

But the argument that a correct result may sometimes be obtained by reasoning on imperfect hypotheses raises the question as to whether another danger may not be imminent. To be satisfactory our model of nature must be unique, and it must be impossible to imagine any other which agrees equally well with the facts of experiment. If a large number of hypotheses could be framed with equal claims to validity, that fact would alone raise grave doubts as to whether it were possible to distinguish between the true and the false. Thus, Professor Poincaré has shown that an infinite number of dynamical explanations can be found for any phenomenon which satisfies certain conditions. But though this consideration warns us against the too ready acceptance of explanations of isolated phenomena, it has no weight against a theory which embraces so vast a number of facts as those included by the atomic theory. It does not follow that because a number of solutions are all formally dynamical they are therefore all equally admissible. The pressure of a gas may be explained as the result of a shower of blows delivered by molecules, or by a repulsion between the various parts of a continuous medium. Both solutions are expressed in dynamical language, but one is and the other is not compatible with the observed phenomena of expansion. The atomic theory must hold the field until another can be found which is not inferior as an explanation of the fundamental difficulties as to the constitution of matter and is, at the same time, not less comprehensive.

On the whole, then, the question as to whether we are attempting to solve a problem which has an infinite number of solutions may be put aside until one solution has been found which is satisfactory in all its details. We are in a sufficient difficulty about that to make the rivalry of a second of the same type very improbable.

## THE PHENOMENA OF LIFE.

But it may be asked—nay, it has been asked—may not the type of our theories be radically changed? If this question does not merely imply a certain distrust in our own powers of reasoning, it should be supported by some indication of the kind of change which is conceivable.

Perhaps the chief objection which can be brought against physical theories is that they deal only with the inanimate side of nature, and largely ignore the phenomena of life. It is therefore in this direction, if in any, that a change of type may be expected. I do not propose to enter at length upon so difficult a question, but, however we may explain or explain away the characteristics of life, the argument for the truth of the atomic theory would only be affected if it could be shown that living matter does not possess the thermal and mechanical properties, to explain which the atomic theory has been framed. This is so notoriously not the case that there is the gravest doubt whether life can in any way interfere with the action within the organism of the laws of matter in bulk belonging to the domain of mechanics, physics, and chemistry.

Probably the most cautious opinion that could now be expressed on this question is that, in spite of some outstanding difficulties which have recently given rise to what is called Neovitalism, there is no conclusive evidence that living matter can suspend or modify any of the natural laws which would affect it if it were to cease to live. It is possible that though subject to these laws the organism while living may be able to employ, or even to direct, their action within itself for its own benefit, just as it unquestionably does make use of the processes of external nature for its own purposes. But if this be so, the seat of the controlling influence is so withdrawn from view that on the one hand its very existence may be denied, while on the other hand, Professor Haeckel, following Vogt, has recently asserted that "Matter and ether are not dead, and only moved by extrinsic force; but they are endowed with sensation and will; they experience an inclination for condensation, a dislike for strain; they strive after the one and struggle against the other."<sup>a</sup>

But neither unproved assertions of this kind nor the more refined attempts that have been made by others to bring the phenomena of life and of dead matter under a common formula touch the evidence for the atomic theory. The question as to whether matter consists of elements capable of independent motion is prior to and independent of the further questions as to what these elements are and whether they are alive or dead.

The physicist, if he keeps to his business, asserts, as the bases of the atomic theory, nothing more than that he who declines to admit that matter consists of separate moving parts must regard many of

<sup>a</sup> Riddle of the Universe (English translation), 1900, p. 380.



the simplest phenomena as irreconcilable and unintelligible, in spite of the fact that means of reconciling them are known to everybody, in spite of the fact that the reconciling theory gives a general correlation of an enormous number of phenomena in every branch of science, and that the outstanding difficulties are connected not so much with the fundamental hypotheses that matter is composed of distinguishable entities which are capable of separate motions as with the much more difficult problem of what these entities are.

On these grounds the physicist may believe that, though he can not handle or see them, the atoms and molecules are as real as the ice crystals in a cirrus cloud which he can not reach; as real as the unseen members of a meteoric swarm whose death glow is lost in the sunshine, or which sweep past us, unentangled, in the night.

If the confidence that his methods are weapons with which he can fight his way to the truth were taken from the scientific explorer, the paralysis which overcomes those who believe that they are engaged in a hopeless task would fall upon him.

Physiology has specially flourished since physiologists have believed that it is possible to master the physics and chemistry of the framework of living things, and since they have abandoned the attitude of those who placed in the foreground the doctrine of the vital force. To supporters of that doctrine the principle of life was not a hidden directing power which could perhaps whisper an order that the flood gates of reservoirs of energy should now be opened and now closed, and could, at the most, work only under immutable conditions to which the living and the dead must alike submit. On the contrary, their vital force pervaded the organism in all its parts. It was an active and energetic opponent of the laws of physics and chemistry. It maintained its own existence not by obeying but by defying them; and though destined to be finally overcome in the separate campaigns of which each individual living creature is the scene, yet, like some guerrilla chieftain, it was defeated here only to reappear there with unabated confidence and apparently undiminished force.

This attitude of mind checked the advance of knowledge. Difficulty could be evaded by a verbal formula of explanation which in fact explained nothing. If the mechanical, or physical, or chemical causes of a phenomenon did not lie obviously upon the surface, the investigator was tempted to forego the toil of searching for them below; it was easier to say that the vital force was the cause of the discrepancy, and that it was hopeless to attempt to account for the action of a principle which was incomprehensible in its nature.

For the physicist the danger is no less serious, though it lies in a somewhat different direction. At present he is checked in his theories by the necessity of making them agree with a comparatively small number of fundamental hypotheses. If this check were removed his fancy might run riot in the wildest speculations, which would be held

to be legitimate if only they led to formulae in harmony with facts. But the very habit of regarding the end as everything, and the means by which it was attained as unimportant, would prevent the discovery of those fragments of truth which can only be uncovered by the painful process of trying to make inconsistent theories agree, and using all facts, however remote, as the tests of our central generalization.

“Science,” said Helmholtz, “Science, whose very object it is to comprehend Nature, must start with the assumption that Nature is comprehensible.” And again, “The first principle of the investigator of Nature is to assume that Nature is intelligible to us, since otherwise it would be foolish to attempt the investigation at all.” These axioms do not assume that all the secrets of the universe will ultimately be laid bare, but that a search for them is hopeless if we undertake the quest with the conviction that it will be in vain. As applied to life they do not deny that in living matter something may be hidden which neither physics nor chemistry can explain; but they assert that the action of physical and chemical forces in living bodies can never be understood if at every difficulty and at every check in our investigations we desist from further attempts in the belief that the laws of physics and chemistry have been interfered with by an incomprehensible vital force. As applied to physics and chemistry they do not mean that all the phenomena of life and death will ultimately be included in some simple and self-sufficing mechanical theory; they do mean that we are not to sit down contented with paradoxes such as that the same thing can fill both a large space and a little one; that matter can act where it is not, and the like, if by some reasonable hypothesis, capable of being tested by experiment, we can avoid the acceptance of these absurdities. Something will have been gained if the more obvious difficulties are removed, even if we have to admit that in the background there is much that we can not grasp.

#### THE LIMITS OF PHYSICAL THEORIES.

And this brings me to my last point. It is a mistake to treat physical theories in general, and the atomic theory in particular, as though they were parts of a scheme which has failed if it leaves anything unexplained, which must be carried on indefinitely on exactly the same principles, whether the ultimate results are or are not repugnant to common sense.

Physical theories begin at the surface with phenomena which directly affect our senses. When they are used in the attempt to penetrate deeper into the secrets of nature, it is more than probable that they will meet with insuperable barriers; but this fact does not demonstrate that the fundamental assumptions are false, and the question as to whether any particular obstacle will be forever insuperable can rarely be answered with certainty.

Those who belittle the ideas which have of late governed the advance

of scientific theory too often assume that there is no alternative between the opposing assertions that atoms and the ether are mere figments of the scientific imagination, or that, on the other hand, a mechanical theory of the atoms and of the ether, which is now confessedly imperfect, would, if it could be perfected, give us a full and adequate representation of the underlying realities.

For my own part I believe that there is a *via media*.

A man peering into a darkened room, and describing what he thinks he sees, may be right as to the general outline of the objects he discerns, wrong as to their nature and their precise forms. In his description fact and fancy may be blended, and it may be difficult to say where the one ends and the other begins; but even the fancies will not be worthless if they are based on a fragment of truth, which will prevent the explorer from walking into a looking-glass or stumbling over the furniture. He who saw "men as trees walking" had at least a perception of the fundamental fact that something was in motion around him.

And so, at the beginning of the twentieth century, we are neither forced to abandon the claim to have penetrated below the surface of nature, nor have we, with all our searching, torn the veil of mystery from the world around us.

The range of our speculations is limited both in space and time; in space, for we have no right to claim, as is sometimes done, a knowledge of the "infinite universe;" in time, for the cumulative effects of actions which might pass undetected in the short span of years of which we have knowledge, may, if continued long enough, modify our most profound generalizations. If some such theory as the vortex-atom theory were true, the faintest trace of viscosity in the primordial medium would ultimately destroy matter of every kind. It is thus a duty to state what we believe we know in the most cautious terms, but it is equally a duty not to yield to mere vague doubts as to whether we can know anything.

If no other conception of matter is possible than that it consists of distinct physical units—and no other conception has been formulated which does not blur what are otherwise clear and definite outlines—if it is certain, as it is, that vibrations travel through space which can not be propagated by matter, the two foundations of physical theory are well and truly laid. It may be granted that we have not yet framed a consistent image either of the nature of the atoms or of the ether in which they exist; but I have tried to show that in spite of the tentative nature of some of our theories, in spite of many outstanding difficulties, the atomic theory unifies so many facts, simplifies so much that is complicated, that we have a right to insist—at all events till an equally intelligible rival hypothesis is produced—that the main structure of our theory is true; that atoms are not merely helps to puzzled mathematicians, but physical realities.



## A CENTURY OF THE STUDY OF METEORITES. <sup>a</sup>

---

By Dr. OLIVER C. FARRINGTON,  
*Curator of Geology, Field Columbian Museum.*

---

The close of the nineteenth century will mark the end of the first century of the study of meteorites. Up to the beginning of this century the attitude of scientific men toward the accounts of stones reported to have fallen from the sky was in general one of scorn and incredulity. Thus an account prepared with great care by the municipality of Juillac, France, telling of a stone shower which occurred there in July, 1790, was characterized by Berthelon at the time as "a recital, evidently false, of a phenomenon physically impossible" and "calculated to excite the pity not only of physicists but of all reasonable people." Bonn, in his *Lithophylacium Bonniannum*, refers to the Tabor, Bohemia, meteorite which fell in 1753, as "e coelo pluisse creduliores quidam asseverant." Chladni, writing in the early part of the century, speaks of many meteorites which were thrown away in his day because the directors of museums were ashamed to exhibit stones reported to have fallen from the sky. President Jefferson when told that Professors Silliman and Kingsley had described a shower of stones as having taken place at Weston, Connecticut, in 1807, said: "It is easier to believe that two Yankee professors will lie than to believe that stones will fall from heaven."

The change of opinion on the part of intelligent and especially scientific men, which took place at the beginning of this century, was due largely to the investigation by the French Academy of the shower of stones which fell at L'Aigle in 1803. This investigation established so absolutely the fact of the fall to the earth at L'Aigle of stones from outer space that scientific men were logically compelled to give credence to the reports of similar occurrences elsewhere. Further, the papers of Chladni and Howard published about the same time, strenuously urging that other masses reported to have fallen upon the earth could not, because of their structure and composition, be of terrestrial origin, had much to do with fixing the growing faith that solid cosmic

---

<sup>a</sup> Reprinted by permission from *Popular Science Monthly*, Vol. LVII, February, 1901.

matter not of terrestrial origin does at intervals come to the earth. Since this beginning the study of meteorites has been one of constantly widening interest and purport.

The essentially distinguishing features of meteorites were early made out. Howard in 1802, from a chemical investigation of various "stony and metallic substances which at different times are said to have fallen on the earth, also of various kinds of native iron," drew the conclusion that a content of nickel characterized most such bodies. He also found that the meteoric stones were made up chiefly of silica and magnesia and that the iron sulphide of meteorites was distinct from the terrestrial mineral pyrite. He further noted the chondritic structure as characteristic of many of the meteoric stones. The correctness of his observations was soon confirmed by analyses made by Fourcroy, John, Klaproth, and others. In 1808 Alois von Widmanstätten, by heating a section of the Agram iron, brought out the figures which have since proved so characteristic of meteoric irons in general and which are now known by his name. Thus the data were early at hand for distinguishing meteorites from terrestrial bodies, and it soon became possible to collect the "sky stones" even when they had not been seen to fall. Systematic efforts for the collection of these bodies were not put forth, however, for many years. Up to 1835 there were only 56 different meteorite falls represented in the Vienna collection, and in 1856 only 136. Up to 1860 those of the British Museum collection numbered only 68 and those of the Paris collection only 64. The studies of these bodies during the first half of the century were made, therefore, upon a relatively limited number. The earlier investigations were chiefly chemical in character, various elements being discovered in succession. Manganese was discovered in the stone of Siena by Klaproth in 1803, chromium in the stone of Vago by Laugier in 1806, carbon in that of Alais by Thenard in 1808, chlorine in that of Stannern by Scheerer in the same year, and cobalt by John in the Pallas iron in 1817. The number of elements discovered since has brought the total up to 29, none being found, however, which are not already known upon the earth. Many of the chemical compounds of meteorites were early isolated and their identity with terrestrial minerals established. Count Bournon showed in 1802 that the transparent green mineral accompanying the iron of Krasnojarsk was olivine. The same mineral was found in other meteorites by later observers, and Rose was able in 1825 to make angular measurements of the crystals which showed them to be identical with those of terrestrial olivine. Laugier separated chromite from the stones of Ensisheim and L'Aigle in 1806. Augite was recognized by Mohs in the stone of Stannern in 1824 and by Rose in that of Juvinas in 1825. Haüy recognized a feldspar which he thought to be orthoclase in the stone of Juvinas in 1822, but three years later Rose showed it to

be plagioclase; and the existence of orthoclase in meteorites has yet to be proved. Continued investigations of the compounds found in meteorites up to the present time have resulted in the detection of at least 21 whose composition is certain, besides several of a somewhat problematic nature. Of these compounds seven have been found to differ in composition from any known terrestrial substances. The character of these indicates the complete absence of water and of oxygen in any large amount from that portion of nature's laboratory where meteorites are formed. Important investigations as to the gases occluded by meteorites were begun by Boussingault in 1861 and have been continued by Wright, Ansdell, Dewar, and others. It has been proved that large quantities of hydrogen, as well as carbonic acid gas, are contained in these bodies, under pressure greater than that of the earth's atmosphere. These investigations led further to the spectroscopic study of meteorites by Vogel, Wright, and Lockyer. The spectra thus obtained, when compared with those exhibited by comets, showed striking resemblances, which have led to a growing belief among scientific men in the identity of origin of comets and meteorites. Lockyer has indeed pushed this conclusion to the point of believing that "all self-luminous bodies in the celestial spaces are composed either of swarms of meteorites or of masses of meteoric vapor produced by heat," and he draws from this many important deductions relating to the origin of the stars, comets and nebulae, and the physical conditions prevailing in them. It will remain for the twentieth century to test the correctness of such conclusions, but the facts already brought out have considerably shaken the confidence hitherto placed in the nebular hypothesis. Another interesting result of the century has been the establishment of a general similarity between shooting stars and meteorites. This idea was first suggested by Chladni in 1798, but it has remained for Newton, Adams, and Schiaparelli to give it shape and proof. The general verdict of science is now in accord with the belief of Newton, "that from the faintest shooting star to the largest stone meteor we pass by such small gradations that no clear dividing lines can separate them into classes." Moreover, the long-existing belief in *le vide planétaire*, space filled only with a mysterious fluid called ether, has been shown to be untenable. Careful records and estimates have shown that 20,000,000 cosmic bodies large enough to produce the phenomena of shooting stars are encountered by the earth daily. The number of these bodies existing in space must be, therefore, beyond all calculation, and their existence implies that of smaller particles in sufficient number to form a widely pervasive cosmic dust. Many remarkable meteorite falls have occurred during the century. Beginning with the stone shower of L'Aigle in 1803, when 2,000 to 3,000 stones fell, no less than eleven such showers have been recorded. In the shower of Pultusk, Poland, which occurred in 1868, 100,000

stones are estimated to have fallen, their total weight reaching over 400 pounds. In the shower at Moes, Germany, in 1882, more than 3,000 stones fell. In our own country about 750 pounds of meteoric matter fell at Estherville, Iowa, in 1879, and several thousand stones fell over an area 9 miles in length and 1 mile wide near Forest City, Iowa, in 1890. Many of these falls have been marked by extraordinary phenomena of light and sound, making them events never to be forgotten by those who witnessed them and worthy to be reckoned among the most remarkable natural occurrences of the century. About 285 actually observed meteoric falls is the total recorded during the century. It is a remarkable fact regarding the nature of the material fallen that only 5 of these have been of meteoric irons. One of these irons fell at Mazapil, Mexico, during the star shower of November, 1885, at the time when the return of Biela's comet was looked for, and was thus considered an occurrence corroborative of the already suspected relationship among comets, shooting stars, and meteorites.

The indifference to the collecting of meteorites which characterized the early part of the century has given place in its latter days to an extraordinary diligence in the search for these bodies. One meteorite has of late acquired a value equal to four times its weight in gold, and several can be sold for two and three times their weight by the gold standard. The meteorite collection of the Natural History Museum in Vienna has for many years been the leading one. What it has cost to build it up may be known from the fact that it is considered the most valuable of any single collection in that great treasure house. Representatives of over 500 meteoric falls are exhibited in this collection, and the meteoric matter has a total weight of 7 tons. The collection of the British Museum of Natural History is nearly as large, while at Paris, Berlin, St. Petersburg, and Calcutta, together with Washington, Chicago, Cambridge, and New Haven, in our own country, are gathered extensive and important collections. The establishment of such large collections has for the first time put the study of meteorites on a satisfactory basis and given lively hope that important truths will be discovered by researches thus made possible. The general similarity of the stony meteorites to the basic volcanic rocks of the earth has been established, and similarity of many physical structures such as brecciation, slicken-sided surfaces, and veins has been proved. The chondritic structure and the crystalline structure represented by the Widmanstätten figures are, however, so far as is yet known, peculiar to meteorites, and it will remain for the twentieth century to discover what these structures mean. Classifications of meteorites based on their mineralogical and structural characters have been established, and important differences among meteorites shown, in spite of their family resemblances. It would be idle perhaps to recount, as might



be done, many theories regarding the nature and origin of meteorites which have been found untenable as a result of the century's study. The theory of the lunar origin of meteorites had at times such able supporters as Laplace and J. Lawrence Smith. Other able observers have believed meteorites to be material ejected at some past period from the earth's volcanoes, some have regarded them of solar origin, and still others as fragments of a shattered planet. All of these theories may be said to have been proved fallacious. The discovery reported by Hahn in 1880 of remains of sponges, corals, and plants in meteorites excited for a time eager inquiries into the possibilities of proving by the study of meteorites the existence of life outside our own globe. No satisfactory evidence of the existence of extraterrestrial life has, however, as yet been obtained from meteorites. The most positive and enduring results of the century's study may, therefore, perhaps be summed up as the establishment of the fact of the fall of solid cosmic matter to the earth and a sufficient knowledge of its nature to distinguish it from matter of terrestrial origin. Satisfactory conclusions as to the origin of this matter and its relations to the visible bodies of the great outlying universe remain yet to be drawn.



## RECENT STUDIES IN GRAVITATION.<sup>a</sup>

By PROF. JOHN H. POYNTING, D. SC., F. R. S.

The studies in gravitation which I am to describe to you this evening will perhaps fall into better order if I rapidly run over the well-beaten track which leads to those studies, the track first laid down by Newton based on astronomical observations, and only made firmer and broader by every later observation.

I may remind you, then, that the motion of the planets round the sun in ellipses, each marking out the area of its orbit at a constant rate, and each having a year proportional to the square root of the cube of its mean distance from the sun, implies that there is a force on each planet exactly proportioned to its mass, directed toward, and inversely as the square of its distance from the sun. The lines of force radiate out from the sun on all sides equally, and always grasp any matter with a force proportional to its mass, whatever planet that matter belongs to.

If we assume that action and reaction are equal and opposite, then each planet acts on the sun with a force proportional to its own mass; and if, further, we suppose that these forces are merely the sum totals of the forces due to every particle of matter in the bodies acting, we are led straight to the law of gravitation, that the force between two masses  $M_1$   $M_2$  is always proportional to the product of the masses divided by the square of the distance  $r$  between them, or is equal to

$$\frac{G \times M_1 \times M_2}{r^2}$$

and the constant multiplier  $G$  is the constant of gravitation.

Since the force is always proportional to the mass acted on, and produces the same change of velocity whatever that mass may be, the change of velocity tells us nothing about the mass in which it takes place, but only about the mass which is pulling. If, however, we compare the accelerations due to different pulling bodies, as for instance that of the sun pulling the earth with that of the earth pulling the moon, or if we compare changes in motion due to the different

<sup>a</sup> From Proceedings of the Royal Institution of Great Britain, Vol. XVI, part 2, November, 1901. Read at weekly evening meeting, Friday, February 23, 1900, His Grace the Duke of Northumberland, K. G., F. S. A., president, in the chair.

planets pulling each other, then we can compare their masses and weigh them one against another and each against the sun. But in this weighing our standard weight is not the pound or kilogram of terrestrial weighings, but the mass of the sun.

For instance, from the fact that a body at the earth's surface, 4,000 miles, on the average, from the mass of the earth, falls with a velocity increasing by 32 ft. / sec.<sup>2</sup>, while the earth itself falls towards the sun, 92,000,000 miles away, with a velocity increasing by about  $\frac{1}{8}$  inch / sec.<sup>2</sup>, we can at once show that the mass of the sun is 300,000 times that of the earth. In other words, astronomical observation gives us only the acceleration, the product of  $G \times$  mass acting, but does not tell us the value of  $G$  nor of the mass acting in terms of our terrestrial standards.

To weigh the sun, the planets, or the earth in pounds or kilograms, or to find  $G$ , we must descend from the heavenly bodies to earthly matter, and either compare the pull of a weighable mass on some body with the pull of the earth on it, or else choose two weighable masses and find the pull between them.

All this was clearly seen by Newton, and was set forth in his *System of the World* (third edition, p. 41).

He saw that a mountain mass might be used, and weighed against the earth by finding how much it deflected the plumb line at its base. The density of the mountain could be found from specimens of the rocks composing it, and the distance of its parts from the plumb line by a survey. The deflection of the vertical would then give the mass of the earth.

Newton also considered the possibility of measuring the attraction between two weighable masses, and calculated how long it would take a sphere a foot in diameter, of the earth's mean density, to draw another equal sphere, with their surfaces separated by one-fourth inch, through that one-fourth inch. But he made a very great mistake in his arithmetic, for while his result gave about one month, the actual time would only be about five and one-half minutes. Had his value been right, gravitational experiments would have been beyond the power of even Professor Boys. Some doubt has been thrown on Newton's authorship of this mistake, but I confess that there is something not altogether unpleasing in the mistake even of a Newton. His faulty arithmetic showed that there was one quality which he shared with the rest of mankind.

Not long after Newton's death the mountain experiment was actually tried, and in two ways. The honor of making these first experiments on gravitation belongs to Bouguer, whose splendid work in this breaking new ground does not appear to me to have received the credit due to it.

One of his plans consisted in measuring the deflection of the plumb

line due to Chimborazo, one of the Andes peaks, by finding the distance of a star on the meridian from the zenith, first at a station on the south side of the mountain, where the vertical was deflected, and then at a station to the west, where the mountain attraction was nearly inconsiderable, so that the actual nearly coincided with the geographical vertical. The difference in zenith distances gave the mountain deflection. It is not surprising that, working in snowstorms at one station and in sand storms at the other, Bouguer obtained a very incorrect result. But at least he showed the possibility of such work, and since his time many experiments have been carried out on his lines under more favorable conditions. Now, however, I think it is generally recognized that the difficulty of estimating the mass of a mountain from mere surface chips is insurmountable, and it is admitted that the experiment should be turned the other way about and regarded

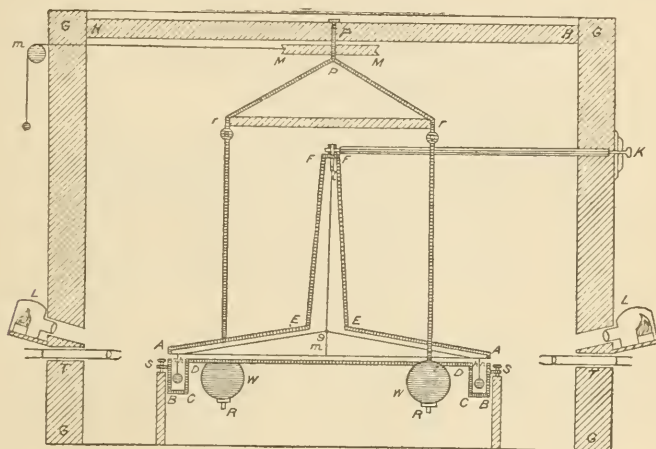

FIG. 1.—Cavendish's apparatus.

as an attempt to measure the mass of the mountains from the density of the earth known by other experiments.

These other experiments are on the line indicated by Newton in his calculations of the attraction of two spheres. The first was carried out by Cavendish.

In the apparatus (fig. 1) he used two lead balls, B B, each 2 inches in diameter. These were hung at the end of a horizontal rod 6 feet long, the torsion rod, and this was hung up by a long wire from its middle point. Two large attracting spheres of lead, W W, each 12 inches in diameter, were brought close to the balls on opposite sides, so that their attractions on the balls conspired to twist the torsion rod round the same way, and the angle of twist was measured. The force could be reckoned in terms of this angle by setting the rod vibrating to and fro and finding the time of vibration, and the force came out to less than one three-thousandth of a grain. Knowing  $M_1 M_2$  and  $r$ , the

distance between them and the force  $G M_1 M_2 / r^2$ , of course Cavendish's result gives  $G$ , or, knowing the attraction of a big sphere on a ball, and knowing the attraction of the earth on the same ball—that is, its weight—the experiment gives the mass of earth in terms of that of the big sphere, and so its mean density. This experiment has often been repeated, but I do not think it is too much to say that no advance was made in exactness till we come to quite recent work.

By far the most remarkable recent study in gravitation is Professor Boys's beautiful form of the Cavendish experiment, a research which

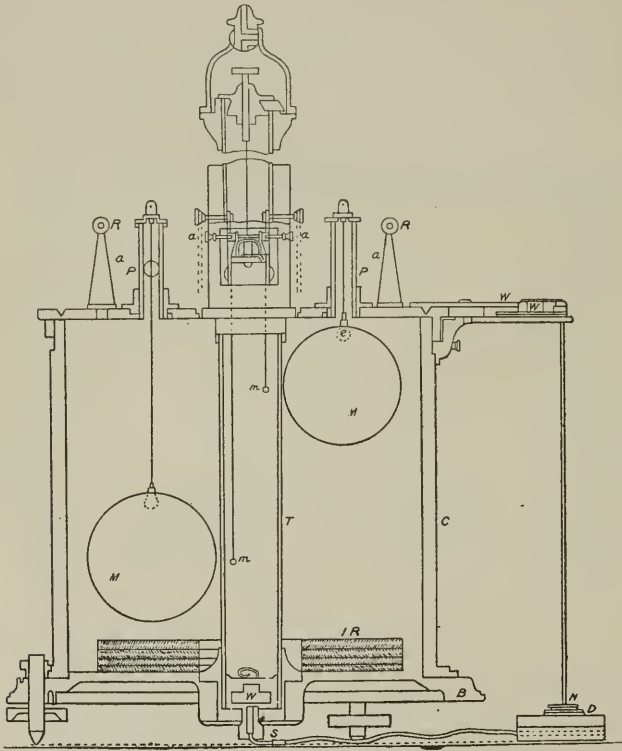

FIG. 2.—Boys's apparatus.

stands out as a model in beauty of design and in exactness of execution (fig. 2). But as Professor Boys has described his experiment already in this theater,<sup>a</sup> it is not necessary for me to more than refer to it. It is enough to say that he made the great discovery, obvious, perhaps, when made, that the sensitiveness of the apparatus is increased by reducing its dimensions. He therefore decreased the scale as far as was consistent with exact measurement of the parts of the apparatus, using a torsion rod, itself a mirror, only 2 inches long, gold balls,  $m m$ , only  $\frac{1}{4}$  inch in diameter, and attracting lead masses,  $M M$ ,

<sup>a</sup> Proc. Royal Institution, XIV, part 2, 1894, p. 353.

only  $4\frac{1}{4}$  inches in diameter. The force to be measured was less than  $1\frac{1}{5} \times 10^6$  grain.

The exactness of his work was increased by using as suspending wire one of his quartz threads. It would be difficult to overestimate the service he has rendered in the measurement of small forces by the discovery of the remarkable properties of these threads.

One of the chief difficulties in the measurement of these small gravitational pulls is the disturbances which are brought about by the air currents which blow to and fro and up and down inside the apparatus, producing irregular motions in the torsion rod. These, though much reduced, are not reduced in proportion to the diminution of the apparatus.

A very interesting repetition of the Cavendish experiment has lately been concluded by Dr. Braun<sup>a</sup> at Mariaschein, in Bohemia, in which he has sought to get rid of these disturbing air currents by suspending his torsion rod in a receiver which was nearly exhausted, the pressure being reduced to about one two-hundredth of an atmosphere. The gales which have been the despair of other workers were thus reduced to such gentle breezes that their effect was hardly noticeable. His apparatus was nearly a mean proportional between that of Cavendish and Boys, his torsion rod being about 9 inches long, the balls weighing 54 grams—less than 2 ounces—and the attracting masses either 5 or 9 kilograms. His work bears internal evidence of great care and accuracy, and he obtained almost exactly the same result as Professor Boys.

Dr. Braun carried on his work far from the usual laboratory facilities, far from workshops, and he had to make much of his apparatus himself. His patience and persistence command our highest admiration.

I am glad to say that he is now repeating the experiment, using as suspension a quartz fiber supplied to him by Professor Boys in place of the somewhat untrustworthy metal wire which he used in the work already published.

Professor Boys has almost indignantly disclaimed that he was engaged on any such purely local experiment as the determination of the mean density of the earth. He was working for the universe, seeking the value of  $G$ , information which would be as useful on Mars or Jupiter or out in the stellar system as here on the earth. But perhaps we may this evening consent to be more parochial in our ideas and express the results in terms of the mean density of the earth. In such terms, then, both Boys and Braun find that density 5.527 times the density of water, agreeing therefore to 1 in 5,000.

There is another mode of proceeding which may be regarded as the

<sup>a</sup> Denkschriften der Math. Wiss. Classe der Kais. Akad. der Wissenschaften Wien, LXIV, 1896.

Cavendish experiment turned from a horizontal into a vertical plane, and in which the torsion balance is replaced by the common balance. This method occurred about the same time to the late Prof. U. Jolly and myself. The principle of my own experiment<sup>a</sup> will be sufficiently indicated by fig. 3. A big bullion balance with a 4-foot beam had two lead spheres, A B, each about 50 pounds in weight, hanging from the two ends in place of the usual scale pans. A large lead sphere, M, 1 foot in diameter and weighing about 350 pounds, was brought first under one hanging weight, then under the other. The pull of the lead sphere acted first on one side alone and then on the

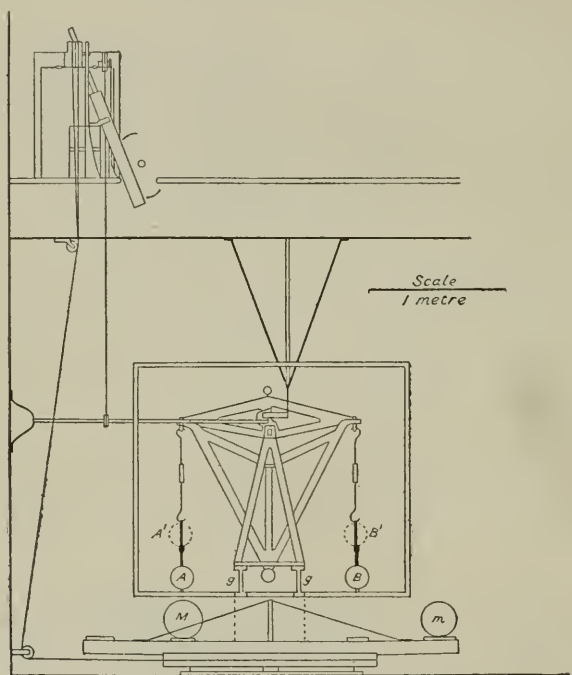

FIG. 3.—Common balance experiment (Poynting).

other so that the tilt of the balance beam when the sphere was moved round was due to twice the pull. By means of riders the tilt and therefore the pull was measured directly as so much increase in weight. This increase, when the sphere was brought directly under the hanging weight with 1 foot between the centers, was about one-fifth mgm. in a total weight of 20 kilograms, or about 1 in 100,000,000. If, then, a sphere one foot away pulls with  $1/10^8$  of the earth's pull, the earth being on the average 20,000,000 feet away, it is easy to see that the earth's mass is calculable in terms of the mass of the sphere, and its

<sup>a</sup> Phil. Trans. 182, 1891, A, p. 565.



density is at once deduced. The direct aim of this experiment, then, is not  $G$ , but the mass of the earth.

It is not a little surprising that the balance could be made to indicate such a small increase in weight as 1 in 100,000,000. But not only did it indicate, it measured the increase, with variations usually well within 1 per cent of the double attraction, or to 1 in 5,000,000,000 of the whole weight, a change in weight which would occur merely if one of the spheres were moved one-fortieth inch nearer the earth's center. This accuracy is only attained by never lifting the knife edges and planes during an experiment, thus keeping the beam in the same state of strain throughout, and, further, by taking care that none of the mechanism for moving the weights or riders shall be attached in

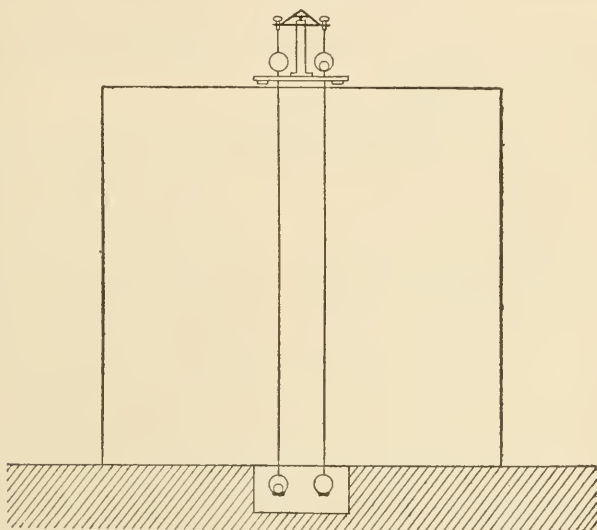

FIG. 4.—Common balance experiment (Richarz and Krigar-Menzel).

any way to the balance or its case; two conditions which are absolutely essential if we are to get the best results of which the balance is capable.

Quite recently another common balance experiment has been brought to a conclusion by Professor Richarz and Dr. Krigar-Menzel<sup>a</sup> at Spandau, near Berlin. Their method may be gathered from fig. 4. A balance of 23 cm., say 9-inch beam, was mounted above a huge lead pile about 2 meters cube, and weighing 100,000 kilograms.

Two pans were supported from each end of the beam, one pan above the other pan below the lead cube, the suspending wires of the lower pans going through narrow vertical tubular holes in the lead. Instead

<sup>a</sup> Anhang zu den Abhandlungen der Königl. Preuss. Akad. der Wissenschaften zu Berlin, 1898.

of moving the attracting mass, the attracted mass was moved. Masses of 1 kilogram each were put first, say, one in the upper right-hand pan, the other in the lower left-hand pan, when the pull of the lead block made the right hand heavier and the left hand lighter. Then the weights were changed to the lower right hand and the upper left hand, when the pulls of the lead pile were reversed. When we remember that in my experiment a lowering of the hanging sphere by  $1\frac{1}{2}$  inches would give an effect as great as the pull I was measuring, it is evident that here the approach to and removal from the earth by over 2 meters would produce very considerable changes in weight, and, indeed, these changes masked the effect of the attraction of the lead. Preliminary experiments had, therefore, to be made before the lead pile was built up, to find the change in weight due to removal from upper to lower pan, and this change had to be allowed for. The quadruple attraction of the lead pile came out at 1.3664 mgm., and the mean density of the earth at 5.505.

This agrees nearly with my own result of 5.49, and it is a curious coincidence that the two most recent balance experiments agree very

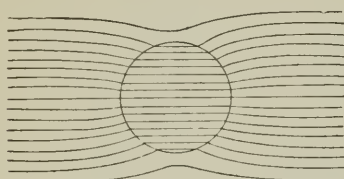

Fig. 5.—Paramagnetic sphere placed in a previously straight field.

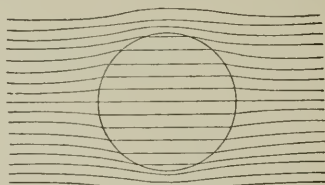

Fig. 6.—Diamagnetic sphere placed in a previously straight field.

nearly at, say, 5.5, and the two most recent Cavendish experiments agree at, say, 5.53, but I confess I think it is merely a coincidence. I have no doubt that the torsion experiment is the more exact, though probably an experiment on different lines was worth making, and I am quite content to accept the value 5.527 as the standard value for the present.

And so the latest research has amply verified Newton's celebrated guess that "the quantity of the whole matter of the earth may be five or six times greater than if it consisted all of water."

I now turn to another line of gravitational research. When we compare gravitation with other known forces (and those which have been most closely studied are electric and magnetic forces) we are at once led to inquire whether the lines of gravitative force are always straight lines radiating from or to the mass round which they center, or whether, like electric and magnetic lines of force, they have a preference for some media and a distaste for others. We know, for example, that if a magnetic sphere of iron or cobalt or manganese is placed in a previously straight field its permeability is greater than

the air it replaces, and the lines of force crowd into it, as in fig. 5. The magnetic action is then stronger in the presence of the sphere near the ends of a diameter parallel to the original course of the lines of force and the lines are deflected. If the sphere be diamagnetic, of water, or copper, or bismuth, the permeability being less than that of air, there is an opposite effect, as in fig. 6, and the field is weakened at the end of a diameter parallel to the lines of force, and again the lines are deflected. Similarly a dielectric body placed in an electric field gathers in the lines of force and makes the field where the lines enter and leave stronger than it was before.

If we inclose a magnet in a hollow box of soft iron placed in a magnetic field, the lines of force are gathered into the iron and largely cleared away from the inside cavity, so that the magnet is screened from external action.

Now, common experience might lead us at once to say that there is no very considerable effect of this kind with gravitation. The evidence of ordinary weighings may perhaps be rejected,

inasmuch as both sides will be equally affected as the balance is commonly used. But a spring balance should show if there is any large effect when used in different positions above different media or in different inclosures, and the ordinary balance is used in certain experiments in which one weight is suspended beneath the balance case and surrounded perhaps by a metal case or perhaps by a water bath. Yet no appreciable variation of weight on that account has yet been noted, nor does the direction of the vertical change rapidly from place to place, as it would with varying permeability of the ground below. But perhaps the agreement of pendulum results, whatever the block on which the pendulum is placed and whatever the case in which it is contained, gives the best evidence that there is no great gathering in or opening out of the lines of the earth's force by different media.

Still, a direct experiment on the attraction between two masses with different media interposed was well worthy of trial, and such an experiment has lately been carried out in America by Messrs. Austin and Thwing.<sup>a</sup> The effect to be looked for will be understood from fig. 7. If a medium more permeable to gravitation is interposed between two bodies, the lines of force will move into it from each side, and the gravitative pull on a body near the interposed medium on the side away from the attracting body will be increased.

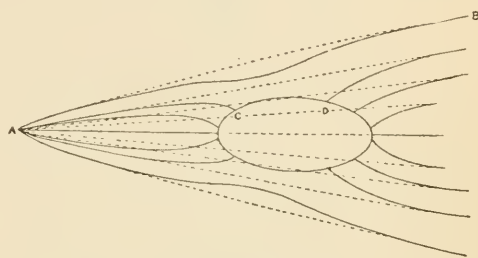

FIG. 7.—Effect of interposition of more permeable medium in radiating field of force.

<sup>a</sup>Physical Review, V, 1897, p. 294.

The apparatus they used was a modified kind of Boys's apparatus (fig. 8). Two small gold masses, in the form of short vertical wires, each 0.4 gm. in weight, were arranged at different levels at the ends virtually of a torsion rod 8 mm. long. The attracting masses  $M_1$ ,  $M_2$  were lead, each about 1 kgm. These were first in the positions shown by black lines in the figure, and were then moved into the positions shown by dotted lines. The attraction was measured first when merely the air and the case of the instrument intervened, and then when various slabs, each 3 cm. thick, 10 cm. wide, and 29 cm. high, were interposed. With screens of lead, zinc, mercury, water, alcohol, or glycerin, the change in attraction was at the most about 1 in 500,

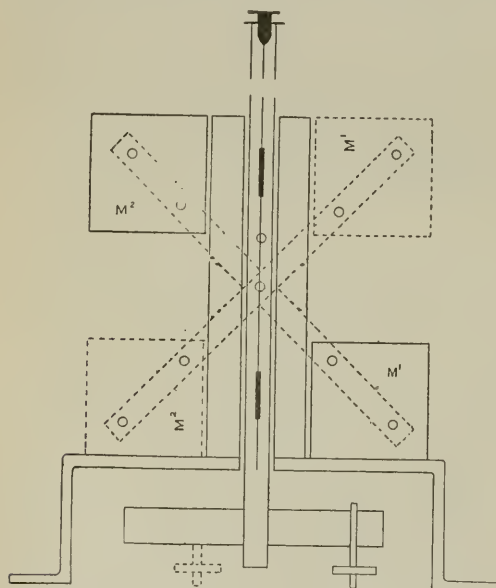

FIG. 8.—Experiment on gravitative permeability (Austin and Thwing).

and this did not exceed the errors of experiment. That is, they found no evidence of a change in pull with change of medium. If such change exists, it is not of the order of the change of electric pull with change of medium, but something far smaller. Perhaps it still remains just possible that there are variations of gravitational permeability comparable with the variations of magnetic permeability in media such as water and alcohol.

Yet another kind of effect might be suspected. In most crystalline substances the physical properties are different along different directions in a crystal. They expand differently, they conduct heat differently, and they transmit light at different speeds in different directions.

We might, then, imagine that the lines of gravitative force spread out from, say, a crystal sphere unequally in different directions. Some years ago, Dr. Mackenzie<sup>a</sup> made an experiment in America, in which he sought for direct evidence of such unequal distribution of the lines of force. He used a form of apparatus like that of Professor Boys (fig. 2), the attracting masses being calc spar spheres about 2 inches in diameter. The attracted masses in one experiment were small lead spheres about one-half gm. each, and he measured the attraction between the crystals and the lead when the axes of the crystals were

<sup>a</sup>Physical Review, II, 1895, p. 321.

set in various positions. But the variation in the attraction was merely of the order of error of experiment. In another experiment the attracted masses were small calc spar crystal cylinders, weighing a little more than one-half gm. each. But again there was no evidence of variation in the attraction with variation of axial direction.

Practically the same problem was attacked in a different way by Mr. Gray and myself.<sup>a</sup> We tried to find whether a quartz crystal sphere had any directive action on another quartz crystal sphere close to it, whether they tended to set with their axes parallel or crossed.

It may easily be seen that this is the same problem by considering what must happen if there is any difference in the attraction between two such spheres when their axes are parallel and when they are crossed. Suppose, for example, that the attraction is always greater when their axes are parallel, and this seems a reasonable supposition, inasmuch as in straightforward crystallization successive parts of the crystal are added to the existing crystal, all with their axes parallel. Begin, then, with two quartz crystal spheres near each other, with their axes in the same plane, but perpendicular to each other. Remove one to a very great distance, doing work against their mutual attractions. Then, when it is quite out of range of appreciable action, turn it round till its axis is parallel to that of the fixed crystal. This absorbs no work if done slowly. Then let it return. The force on the return journey at every point is greater than the force on the outgoing journey, and more work will be got out than was put in. When the sphere is in its first position, turn it round till the axes are again at right angles. Then work must be done on turning it through this right angle to supply the difference between the outgoing and incoming works. For, if no work were done in the turning, we could go through cycle after cycle, always getting a balance of energy over, and this would, I think, imply either a cooling of the crystals or a diminution in their weight, neither supposition being admissible. We are led, then, to say that if the attraction with parallel axes exceeds that with crossed axes, there must be a directive action resisting the turn from the crossed to the parallel positions. And, conversely, a directive action implies axial variation in gravitation.

The straightforward mode of testing the existence of this directive action would consist in hanging up one sphere by a wire or thread and turning the other round into various positions and observing whether the hanging sphere tended to twist out of position. But the action, if it exists, is so minute and the disturbances due to air currents are so great that it would be extremely difficult to observe its effect directly. It occurred to us that we might call in the aid of the

---

<sup>a</sup> Phil. Trans. 192, 1899, A, p. 245.

principle of forced oscillations by turning one sphere round and round at a constant rate, so that the couple would act first in one direction and then in the other, alternately, and so set the hanging sphere vibrating to and fro. The nearer the complete time of vibration of the applied couple to the natural time of vibration of the hanging sphere, the greater would be the vibration set up. This is well illustrated by moving the point of suspension of a pendulum to and fro in gradually decreasing periods, when the swing gets longer and longer, till the period is that of the pendulum, and then decreases again; or,

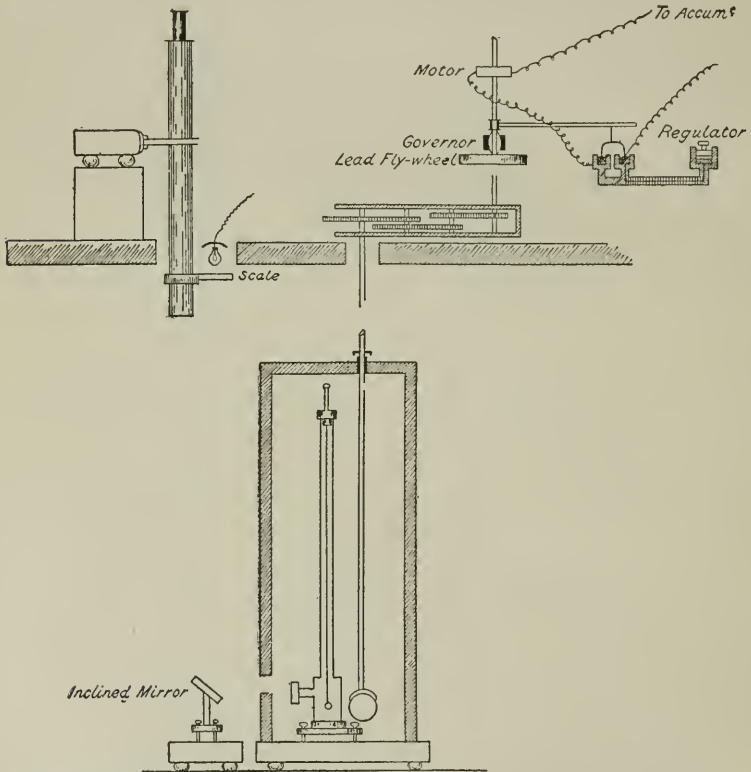

FIG. 9.—Experiment on directive action of one quartz crystal on another.

by the experiment of varying the length of a jar resounding to a given fork, when the sound suddenly swells out as the length becomes that which would naturally give the same note as the fork. Now, in looking for the couple between the crystals, there are two possible cases. The most likely is that in which the couple acts in one way while the turning sphere is moving from parallel to crossed, and in the opposite way during the next quarter turn from crossed to parallel; that is, the couple vanishes four times during the revolution, and this we may term a quadrantal couple; but it is just possible that a quartz crystal

has two ends, like a magnet, and that like poles tend to like directions. Then, the couple will vanish only twice in a revolution and may be termed a semicircular couple. We looked for both, but it is enough now to consider the possibility of the quadrantal couple only.

Our mode of working will be seen from fig. 9. The hanging sphere, 0.9 cm. in diameter and 1 gm. in weight, was placed in a light aluminum wire cage with a mirror on it, and suspended by a long quartz fiber in a brass case with a window in it opposite the mirror, and surrounded by a double-walled, tinfoiled wood case. The position of the sphere was read in the usual way, by scale and telescope. The time of swing of this little sphere was one hundred and twenty seconds.

A larger quartz sphere, 6.6 cm. diameter and weighing 400 gms., was fixed at the lower end of an axis, which could be turned at any desired rate by a regulated motor. The centers of the spheres were

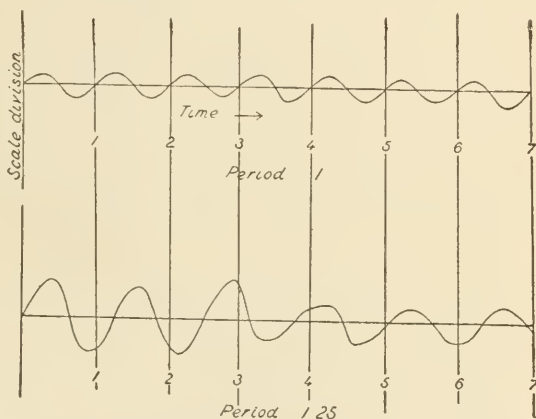

FIG. 10.—Upper curve in regular vibration. Lower curve a disturbance dying away.

on the same level and 5.9 cm. apart. On the top of the axis was a wheel with 20 equidistant marks on its rim, one passing a fixed point every eleven and five-tenths seconds.

It might be expected that the couple, if it existed, would have the greatest effect if its period exactly coincided with the one hundred and twenty second period of the hanging sphere. i. e., if the larger sphere revolved in two hundred and forty seconds; but in the conditions of the experiment the vibrations of the small sphere were very much damped, and the forced oscillations did not mount up as they would in a freer swing. The disturbances, which were mostly of an impulsive kind, continually set the hanging sphere into large vibration, and these might easily be taken as due to the revolving sphere. In fact, looking for the couple with exactly coincident periods would be something like trying to find if a fork set the air in a resonating jar vibrating when a brass band was playing all round it. It was necessary to

make the couple period, then, a little different from the natural one hundred and twenty second period, and accordingly we revolved the large sphere once in two hundred and thirty seconds, when the supposed quadrantal couple would have a period of one hundred and fifteen seconds.

Figs. 10 and 11 may help to show how this enabled us to eliminate the disturbances. Let the ordinates of the curves in fig. 10 represent vibrations set out to a horizontal time scale. The upper curve is a regular vibration of range  $\pm 3$ , the lower a disturbance beginning with range  $\pm 10$ . The first has period 1, the second period 1.25. Now, cutting the curves into lengths equal to the period of the shorter time of vibration and arranging the lengths one under the other, as in fig. 11, it will be seen that the maxima and the minima of the regular

vibration always fall at the same points, so that, taking 7 periods and adding up the ordinates, we get 7 times the range, viz,  $\pm 21$ . But in the disturbance the maxima and minima fall at different points, and even with 7 periods only, the range is from  $+16$  to  $-13$ , or less than the range due to the addition of the much smaller regulation vibration.

In our experiment the couple, if it existed, would very soon establish its vibration, which would always be there and would go through all its values in one hundred and fifteen seconds. An observer, watching the wheel at the top of the revolving axis, gave the time signals every eleven and five-tenth seconds, regulating the speed if necessary, and an observer at the telescope gave the scale reading at every signal—that is, 10 times during the period. The values were

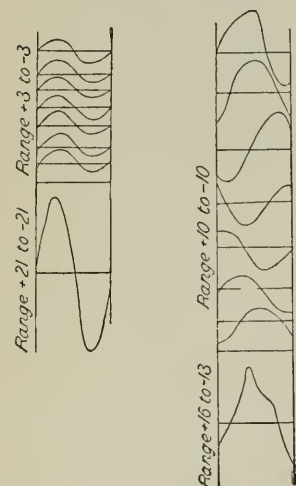

FIG. 11.—Results of superposition of lengths of curves in fig. 10 equal to the period of the regular one.

arranged in 10 columns, each horizontal line giving the readings of a period. The experiment was carried on for about two and one-half hours at a time, covering, say, 80 periods. On adding up the columns the maxima and minima of the couple effect would always fall in the same two columns, and so the addition would give 80 times the swing, while the maxima and minima of the natural swings due to disturbances would fall in different columns, and so, in the long run, neutralize each other. The results of different days' work might, of course, be added together.

There always was a small outstanding effect, such as would be produced by a quadrantal couple, but its effect was not always in the same columns, and the net result of about three hundred and fifty period observations was that there was no one hundred and fifteen second



vibration of more than 1 second of arc, while the disturbances were sometimes 50 times as great.

The semicircular couple required the turning sphere to revolve in one hundred and fifteen seconds. Here want of symmetry in the apparatus would come in with the same effect as the couple sought, and the outstanding result was accordingly a little larger.

But in neither case could the experiments be taken as showing a real couple. They only showed that, if it existed, it was incapable of producing an effect greater than that observed.

Perhaps the best way to put the result of our work is this: Imagine the small sphere set with its axis at  $45^\circ$  to that of the other. Then the couple is not greater than one which would take five and one-fourth hours to turn it through that  $45^\circ$  to the parallel position, and it would oscillate about that position in not less than twenty-one hours.

The semicircular couple is not greater than one which would turn from crossed to parallel position in four and one-half hours, and it would oscillate about that position in not less than seventeen hours.

Or, if the gravitation is less in the crossed than in the parallel position, and in a constant ratio, the difference is less than 1 in 16,000 in the one case and less than 1 in 2,800 in the other.

We may compare with these numbers the difference of rate of travel of yellow light through a quartz crystal along the axis and perpendicular to it. That difference is of quite another order, being about 1 in 170.

As to other possible qualities of gravitation, I shall only mention that quite indecisive experiments have been made to seek for an alteration of mass on chemical combination,\* and that at present there is no reason to suppose that temperature affects gravitation. Indeed, as to temperature effect, the agreement of weight methods and volume methods of measuring expansion with rise of temperature is good, as far as it goes, in showing that weight is independent of temperature.

So, while the experiments to determine  $G$  are converging on the same value, the attempts to show that, under  $G$  certain conditions, it may not be constant, have resulted so far in failure all along the line. No attack on gravitation has succeeded in showing that it is related to anything but the masses of the attracting and the attracted bodies. It appears to have no relation to physical or chemical condition of the acting masses or to the intervening medium.

Perhaps we have been led astray by false analogies in some of our questions. Some of the qualities we have sought and failed to find, qualities which characterize electric and magnetic forces, may be due to the polarity, the  $+$  and  $-$ , which we ascribe to poles and charges, and which have no counterpart in mass.

---

\* Landolt, *Zeit. für Phys. Chem.* XII, 1, 1894. Sanford and Ray, *Physical Review*, V, 1897, p. 247.

But this unlikeness, this independence of gravitation of any quality but mass, bars the way to any explanation of its nature.

The dependence of electric forces on the medium, one of Faraday's grand discoveries forever associated with the Royal Institution, was the first step which led on to the electromagnetic theory of light, now so splendidly illustrated by Hertz's electromagnetic waves. The quantitative laws of electrolysis, again due to Faraday, are leading, I believe, to the identification of electrification and chemical separation—to the identification of electric with chemical energy.

But gravitation still stands alone. The isolation which Faraday sought to break down is still complete. Yet the work I have been describing is not all failure. We at least know something in knowing what qualities gravitation does not possess, and when the time shall come for explanation all these laborious and, at first sight, useless experiments will take their place in the foundation on which that explanation will be built.

# ON ETHER AND GRAVITATIONAL MATTER THROUGH INFINITE SPACE.<sup>a</sup>

By LORD KELVIN.

NOTE ON THE POSSIBLE DENSITY OF THE LUMINIFEROUS MEDIUM AND ON THE MECHANICAL VALUE OF A CUBIC MILE<sup>b c</sup> OF SUNLIGHT.<sup>d</sup>

SECTION 1. That there must be a medium forming a continuous material communication throughout space to the remotest visible body is a fundamental assumption in the undulatory theory of light. Whether or not this medium is (as appears<sup>e</sup> to me most probable) a continuation of our own atmosphere, its existence is a fact that can not be questioned when the overwhelming evidence in favor of the undulatory theory is considered; and the investigation of its properties in every possible way becomes an object of the greatest interest. A first question would naturally occur. What is the absolute density of the luminiferous ether in any part of space? I am not aware of any attempt having hitherto been made to answer this question, and the present state of science does not in fact afford sufficient data. It has, however, occurred to me that we may assign an inferior limit to the density of the luminiferous medium in interplanetary space by considering the mechanical value of sunlight as deduced in preceding communications to the Royal Society<sup>f</sup> from Pouillet's data on solar radiation and

<sup>a</sup> Reprinted from the London, Edinburgh, and Dublin Philosophical Magazine and Journal of Science [sixth series], August, 1901, pp. 161-177. [This is an amplification of Lecture XVI, Baltimore, October 15, 1884, now being prepared for print in a volume on Molecular Dynamics and the Wave Theory of Light, which I hope may be published within a year from the present time.]

<sup>b</sup> Note of December 22, 1892.—The brain-wasting perversity of the insular inertia which still condemns British engineers to reckonings of miles and yards and feet and inches and grains and pounds and ounces and acres is curiously illustrated by the title and numerical results of this article as originally published.

<sup>c</sup> October 13, 1899.—In the present reproduction, as part of my Lecture XVI, of Baltimore, 1884, I suggest cubic kilometer instead of "cubic mile" in the title, and use the French metrical system exclusively in the article.

<sup>d</sup> From Edin. Royal Soc. Trans., Vol. XXI, Part I, May, 1854; Phil. Mag., IX, 1854; Comptes Rendus, XXXIX, Sept., 1854; Art. LXVII of Math. and Phys. Papers.

<sup>e</sup> October 13, 1899.—Not so now. I did not in 1854 know the kinetic theory of gases.

<sup>f</sup> Trans. R. S. E.; Mechanical Energies of the Solar System; republished as Art. LXVI of Math. and Phys. Papers.

Joule's mechanical equivalent of the thermal unit. Thus the value of solar radiation per second per square centimeter at the earth's distance from the sun, estimated at 1,235 cm.-grams, is the same as the mechanical value of sunlight in the luminiferous medium through a space of as many cubic centimeters as the number of linear centimeters of propagation of light per second. Hence the mechanical value of the whole energy, kinetic and potential, of the disturbance kept up in the space of a cubic centimeter at the earth's distance from the sun<sup>a</sup> is

$$\frac{1235}{3 \times 10^{10}}, \text{ or } \frac{412}{10^{10}} \text{ of a cm.-gram.}$$

SEC. 2. The mechanical value of a cubic kilometer of sunlight is consequently 412 meter-kilograms, equivalent to the work of one horsepower for five and four-tenths seconds. This result may give some idea of the actual amount of mechanical energy of the luminiferous motions and forces within our own atmosphere. Merely to commence the illumination of 11 cubic kilometers requires an amount of work equal to that of a horsepower for a minute; the same amount of energy exists in that space as long as light continues to traverse it, and, if the source of light be suddenly stopped, must pass from it before the illumination ceases.<sup>b</sup> The matter which possesses this energy is the luminiferous medium. If, then, we knew the velocities of the vibratory motions, we might ascertain the density of the luminiferous medium; or, conversely, if we knew the density of the medium, we might determine the average velocity of the moving particles.

SEC. 3. Without any such definite knowledge we may assign a superior limit to the velocities and deduce an inferior limit to the quantity of matter by considering the nature of the motions which constitute waves of light. For it appears certain that the amplitudes of the vibrations constituting radiant heat and light must be but small fractions of the wave lengths, and that the greatest velocities of the vibrating particles must be very small in comparison with the velocity of propagation of the waves.

SEC. 4. Let us consider, for instance, homogeneous plane polarized light, and let the greatest velocity of vibration be denoted by  $v$ ; the distance to which a particle vibrates on each side of its position of

<sup>a</sup>The mechanical value of sunlight in any space near the sun's surface must be greater than in an equal space at the earth's distance in the ratio of the square of the earth's distance to the square of the sun's radius—that is, in the ratio of 46,000 to 1 nearly. The mechanical value of a cubic centimeter of sunlight near the sun must, therefore, be

$$\frac{1235 \times 46000}{3 \times 10^{10}}, \text{ or about } .0019 \text{ of a cm.-gram.}$$

<sup>b</sup>Similarly we find 4,140 horsepower for a minute as the amount of work required to generate the energy existing in a cubic kilometer of light near the sun.

equilibrium by  $A$ ; and the wave length by  $\lambda$ . Then, if  $V$  denote the velocity of propagation of light or radiant heat, we have

$$\frac{v}{V} = 2\pi \frac{A}{\lambda};$$

and therefore if  $A$  be a small fraction of  $\lambda$ ,  $v$  must also be a small fraction ( $2\pi$  times as great) of  $V$ . The same relation holds for circularly polarized light, since in the time during which a particle revolves once round in a circle of radius  $A$  the wave has been propagated over a space equal to  $\lambda$ . Now, the whole mechanical value of homogeneous plane polarized light in an infinitely small space containing only particles sensibly in the same phase of vibration, which consists entirely of potential energy at the instants when the particles are at rest at the extremities of their excursions, partly of potential and partly of kinetic energy when they are moving to or from their positions of equilibrium, and wholly of kinetic energy when they are passing through these positions, is of constant amount, and must therefore be at every instant equal to half the mass multiplied by the square of the velocity which the particles have in the last-mentioned case. But the velocity of any particle passing through its position of equilibrium is the greatest velocity of vibration. This we have denoted by  $v$ ; and, therefore, if  $\rho$  denote the quantity of vibrating matter contained in a certain space, a space of unit volume, for instance, the whole mechanical value of all the energy, both kinetic and potential, of the disturbance within that space at any time is  $\frac{1}{2}\rho v^2$ . The mechanical energy of circularly polarized light at every instant is (as has been pointed out to me by Professor Stokes) half kinetic energy of the revolving particles and half potential energy of the distortion kept up in the luminiferous medium; and, therefore,  $v$  being now taken to denote the constant velocity of motion of each particle, double the preceding expression gives the mechanical value of the whole disturbance in a unit of volume in the present case.

SEC. 5. Hence, it is clear that for any elliptically polarized light the mechanical value of the disturbance in a unit of volume will be between  $\frac{1}{2}\rho v^2$  and  $\rho v^2$ , if  $v$  still denote the greatest velocity of the vibrating particles. The mechanical value of the disturbance kept up by a number of coexisting series of waves of different periods, polarized in the same plane, is the sum of the mechanical values due to each homogeneous series separately, and the greatest velocity that can possibly be acquired by any vibrating particle is the sum of the separate velocities due to the different series. Exactly the same remark applies to coexistent series of circularly polarized waves of different periods. Hence, the mechanical value is certainly less than half the mass multiplied into the square of the greatest velocity

acquired by a particle, when the disturbance consists in the superposition of different series of plane polarized waves; and we may conclude, for every kind of radiation of light or heat except a series of homogeneous circularly polarized waves, that the mechanical value of the disturbance kept up in any space is less than the product of the mass into the square of the greatest velocity acquired by a vibrating particle in the varying phases of its motion. How much less in such a complex radiation as that of sunlight and heat we can not tell, because we do not know how much the velocity of a particle may mount up, perhaps even to a considerable value in comparison with the velocity of propagation, at some instant by the superposition of different motions chancing to agree; but we may be sure that the product of the mass into the square of an ordinary maximum velocity, or of the mean of a great many successive maximum velocities of a vibrating particle, can not exceed in any great ratio the true mechanical value of the disturbance.

SEC. 6. Recurring, however, to the definite expression for the mechanical value of the disturbance in the case of homogeneous circularly polarized light, the only case in which the velocities of all particles are constant and the same, we may define the mean velocity of vibration in any case as such a velocity that the product of its square into the mass of the vibrating particles is equal to the whole mechanical value, in kinetic and potential energy, of the disturbance in a certain space traversed by it; and from all we know of the mechanical theory of undulations, it seems certain that this velocity must be a very small fraction of the velocity of propagation in the most intense light or radiant heat which is propagated according to known laws. Denoting this velocity for the case of sunlight at the earth's distance from the sun by  $v$ , and calling  $W$  the mass in grams of any volume of the luminiferous ether, we have the mechanical value of the disturbance in the same space, in terms of terrestrial gravitation units,

$$\frac{W}{g}v^2,$$

where  $g$  is the number 981, measuring in (C.G.S.) absolute units of force, the force of gravity on a gram. Now, from Pouillet's observation, we found in the last footnote on section 1 above,  $\frac{1235 \times 46000}{V}$

for the mechanical value, in centimeter-grams, of a cubic centimeter of sunlight in the neighborhood of the sun; and therefore the mass, in grams, of a cubic centimeter of the ether, must be given by the equation,

$$W = \frac{981 \times 1235 \times 46000}{v^2 V}.$$

If we assume  $\nu = \frac{1}{n}V$ , this becomes

$$W = \frac{981 \times 1235 \times 46000}{V^3} \times n^2 = \frac{981 \times 1235 \times 46000}{(3 \times 10^{10})^3} \times n^2 = \frac{20 \cdot 64}{10^{22}} \times n^2 \text{ gm.};$$

and for the mass, in grams, of a cubic kilometer we have  $\frac{20 \cdot 64}{10^7} \times n^2$ .

SEC. 7. It is quite impossible to fix a definite limit to the ratio which  $\nu$  may bear to  $V$ ; but it appears improbable that it could be more, for instance, than one-fiftieth for any kind of light following the observed laws. We may conclude that probably a cubic centimeter of the luminiferous medium in the space near the sun contains not less than  $516 \times 10^{-20}$  of a gram of matter; and a cubic kilometer not less than  $516 \times 10^{-5}$  of a gram.

SEC. 8. [Nov. 16, 1899.—We have strong reason to believe that the density of ether is constant throughout interplanetary and interstellar space. Hence, taking the density of water as unity according to the convenient French metrical system, the preceding statements are equivalent to saying that the density of ether in vacuum or space devoid of ponderable matter is everywhere probably not less than  $5 \times 10^{-18}$ .

Hence the rigidity (being equal to the density multiplied by the square of the velocity of light) must be not less than 4500 dynes<sup>a</sup> per square centimeter. With this enormous value as an inferior limit to the rigidity of the ether, we shall see in an addition to Lecture XIX that it is impossible to arrange for a radiant molecule moving through ether and displacing ether by its translatory as well as by its vibratory motions, consistently with any probable suppositions as to magnitudes of molecules and ruptural rigidity-modulus of ether; and that it is also impossible to explain the known smallness of ethereal resistance against the motions of planets and comets, or of smaller ponderable bodies, such as those we can handle and experiment upon in our abode on the earth's surface, if the ether must be pushed aside to make way for the body moving through it. We shall find ourselves forced to consider the necessity of some hypothesis for the free motion of ponderable bodies through ether, disturbing it only by condensations and rarefactions, with no incompatibility in respect to joint occupation of the same space by the two substances.<sup>b]</sup>

SEC. 9. I wish to make a short calculation to show how much compressing force is exerted upon the luminiferous ether by the sun's attraction. We are accustomed to call ether imponderable. How do we know it is imponderable? If we had never dealt with air except

<sup>a</sup>See Math. and Phys. Papers, Vol. III, p. 522; and in the last line of table 4, for " $\rho > 10^{-22}$ " substitute " $\rho < 10^{-22}$ ."

<sup>b</sup>See Phil. Mag., Aug., 1900, pp. 181-198.

by our senses, air would be imponderable to us; but we know by experiment that a vacuous glass globe shows an increase of weight when air is allowed to flow into it. We have not the slightest reason to believe the luminiferous ether to be imponderable. [Nov. 17, 1899.—I now see that we have the strongest possible reason to believe that ether is imponderable.] It is just as likely to be attracted to the sun as air is. At all events the onus of proof rests with those who assert that it is imponderable. I think we shall have to modify our ideas of what gravitation is, if we have a mass spreading through space with mutual gravitations between its parts without being attracted by other bodies. [Nov. 17, 1899.—But is there any gravitational attraction between different portions of ether? Certainly not, unless either it is infinitely resistant against condensation, or there is only a finite volume of space occupied by it. Suppose that ether is given uniform spread through space to infinite distances in all directions. Any spherical portion of it, if held with its surface absolutely fixed, would by the mutual gravitation of its parts become heterogeneous; and this tendency could certainly not be counteracted by doing away with the supposed rigidity of its boundary and by the attraction of ether extending to infinity outside it. The pressure at the center of a spherical portion of homogeneous gravitational matter is proportional to the square of the radius, and therefore by taking the globe large enough may be made as large as we please, whatever be the density. In fact, if there were mutual gravitation between its parts, homogeneous ether extending through all space would be essentially unstable unless infinitely resistant against compressing or dilating forces. If we admit that ether is to some degree condensable and extensible, and believe that it extends through all space, then we must conclude that there is no mutual gravitation between its parts, and can not believe that it is gravitationally attracted by the sun or the earth or any ponderable matter; that is to say, we must believe ether to be a substance outside the law of universal gravitation.]

SEC. 10. In the meantime it is an interesting and definite question to think of what the weight of a column of luminiferous ether of infinite height resting on the sun would be, supposing the sun cold and quiet, and supposing for the moment ether to be gravitationally attracted by the sun as if it were ponderable matter of density  $5 \times 10^{-18}$ . You all know the theorem for mean gravity due to attraction inversely as the square of the distance from a point. It shows that the heaviness of a uniform vertical column AB, of mass  $m$  per unit length and having its length in a line through the center of force C, is

$$\frac{mv}{CA} - \frac{mv}{CB}; \text{ or } \frac{mv}{CA} \text{ if } CB = \infty,$$





Hence, for a spherical surface, (2) gives

$$Q = \frac{4\pi}{3} r \rho = \frac{M}{r^2} \dots \dots \dots (4).$$

This shows that the average normal component force over the surface S is infinitely great, if  $\rho$  is finite and  $r$  is infinitely great, which suffices to prove section 11.

SEC. 14. For example, let

$$r = 150 \cdot 10^6 \cdot 206 \cdot 10^6 = 3 \cdot 09 \cdot 10^{16} \text{ km.} \dots \dots \dots (5).$$

This is the distance at which a star must be to have parallax one one-thousandth of a second; because the mean distance of the earth from the sun is 150,000,000 kms., and there are 206,000 seconds of angle in the radian. Let us try whether there can be as much matter as a thousand-million times the sun's mass, or, as we shall say for brevity, a thousand-million suns, within a spherical surface of that radius (5). The sun's mass is 324,000 times the earth's mass, and therefore our quantity of matter on trial is  $3 \cdot 24 \cdot 10^{14}$  times the earth's mass. Hence if we denote by  $g$  terrestrial gravity at the earth's surface, we have by (4)

$$Q = 3 \cdot 24 \cdot 10^{14} \left( \frac{6 \cdot 37 \cdot 10^8}{3 \cdot 09 \cdot 10^{16}} \right)^2 g = 1 \cdot 37 \cdot 10^{-11} \cdot g \dots \dots (6).$$

Hence if the radial force were equal over the whole spherical surface, its amount would be  $1 \cdot 37 \cdot 10^{-11}$  of terrestrial surface-gravity; and every body on or near that surface would experience an acceleration toward the center equal to

$$1 \cdot 37 \cdot 10^{-13} \text{ kms. per second per second} \dots \dots (7),$$

because  $g$  is approximately 1,000 cms. per second per second, or .01 km. per second per second. If the normal force is not uniform, bodies on or near the spherical surface will experience centerward acceleration, some at more than that rate, some less. At exactly that rate, the velocity acquired per year (thirty-one and a half million seconds) would be  $4 \cdot 32 \cdot 10^{-6}$  kms. per second. With the same rate of acceleration through five million years the velocity would amount to 21.6 kms. per second, if the body started from rest at our spherical surface; and the space moved through in five million years would be  $\cdot 17 \cdot 10^{16}$  kms., which is only .055 of  $r$  (5). This is so small that the force would vary very little, unless through the accident of near approach to some other body. With the same acceleration constant through twenty-five million years the velocity would amount to 108 kms. per second; but the space moved through in twenty-five million years would be  $4 \cdot 25 \cdot 10^{16}$  kms., or more than the radius  $r$ , which shows that the rate of acceleration could not be approximately constant for nearly as long a time as twenty-five million years. It would, in fact,

have many chances of being much greater than 108 kms. per second, and many chances also of being considerably less.

SEC. 15. Without attempting to solve the problem of finding the motions and velocities of the 1,000,000,000 bodies, we can see that if they had been given at rest<sup>a</sup> twenty-five million years ago distributed uniformly or nonuniformly through our sphere (5) of  $3\cdot09 \cdot 10^{16}$  kms. radius, a very large proportion of them would now have velocities not less than 20 or 30 kms. per second, while many would have velocities less than that; and certainly some would have velocities greater than 108 kms. per second; or if thousands of millions of years ago they had been given at rest, at distances from one another very great in comparison with  $r$  (5), so distributed that they should temporarily now be equably spaced throughout a spherical surface of radius  $r$  (5), their mean velocity (reckoned as the square root of the mean of the squares of their actual velocities), would now be 50·4 kms. per second.<sup>b</sup> This is not very unlike what we know of the stars visible to us. Thus it is quite possible, perhaps probable, that there may be as much matter as a thousand million suns within the distance corresponding to parallax one one-thousandth of a second ( $3\cdot09 \cdot 10^{16}$  kms.). But it seems perfectly certain that there can not be within this distance as much matter as 10,000,000,000 suns; because if there were we should find much greater velocities of visible stars than observation shows, according to the following tables of results and statements from the most recent scientific authorities on the subject.

<sup>a</sup> "The potential energy of gravitation may be in reality the ultimate created antecedent of all the motion, heat, and light at present in the universe." See Mechanical Antecedents of Motion, Heat, and Light. Art. LXIX of my Collected Mathematical and Physical Papers, Vol. II.

<sup>b</sup>To prove this, remark that the exhaustion of gravitational energy

$$(E = \frac{1}{8\pi} \int_{-\infty}^{+\infty} \int_{-\infty}^{+\infty} \int_{-\infty}^{+\infty} R^2 dx dy dz, \text{ Thomson and Tait's Natural Philosophy, Part II, section 549})$$

when a vast number,  $N$ , of equal masses come from rest at infinite distances from one another to an equably spaced distribution through a sphere of radius  $r$  is easily found to be  $3/10 Fr$ , where  $F$  denotes the resultant force of the attraction of all of them on a material point, of mass equal to the sum of their masses, placed at the spherical surface. Now, this exhaustion of gravitational energy is spent wholly in the generation of kinetic energy; and therefore we have

$$\Sigma \frac{1}{2} m^2 = \frac{3}{10} Fr, \text{ and by (7) } F = 1\cdot37 \cdot 10^{-13} \Sigma m; \text{ whence}$$

$$\frac{\Sigma m v^2}{\Sigma m} = \frac{3}{5} 1\cdot37 \cdot 10^{-13} \cdot r$$

which, for the case of equal masses, gives, with (5) for the value of  $r$ ,

$$\sqrt{\frac{\Sigma v^2}{N}} = \sqrt{(\frac{3}{5} 1\cdot37 \cdot 10^{-13} \cdot 3\cdot09 \cdot 10^{16})} = 50\cdot4 \text{ kms. per second.}$$

[From the *Annuaire du Bureau des Longitudes* (Paris, 1901).]

Magnitude.	Name of star.	Distance from earth in million kilometers.	Annual proper motions.	Parallax.	Velocities perpendicular to line of sight in kilometers per second.
0.7	$\alpha$ Centauri.....	43	3.62	0.72	23.9
6.8	21185 Lalande.....	64	4.75	.48	47.1
5.1	61 Cygni.....	70	5.17	.44	55.7
-1.4	Sirius.....	83	1.32	.37	17.
8.2	18609 Arg.-Geltzen.....	88	2.30	.35	31.3
7.9	34 Groombridge.....	99	2.83	.31	43.5
7.5	9352 Lacaille.....	110	6.97	.28	118.5
0.5	Procyon.....	110	1.26	.27	22.2
9.	11677 Arg.-Geltzen.....	119	3.05	.26	55.7
6.5	1643 Fedorenko.....	123	1.43	.25	27.2
8.5	21258 Lalande.....	128	4.40	.24	87.1
4.7	$\sigma$ Draconis.....	128	1.84	.24	36.5
3.6	$\eta$ Cassiopeiæ.....	147	1.19	.21	27.
0.2	$\alpha$ Aurigæ.....	147	0.43	.21	9.8
9.	17415 Arg.-Geltzen.....	154	1.27	.20	30.2
0.9	$\alpha$ Aquilæ.....	154	0.64	.20	15.2
5.2	$\epsilon$ "Indien".....	154	4.60	.20	109.5
4.5	$\alpha^2$ Eridani.....	181	4.05	.17	113.2
2.4	$\beta$ Cassiopeiæ.....	193	0.57	.16	16.9
1.	$\alpha$ Tauri.....	206	0.19	.15	6.
7.	1831 Fedorenko.....	206	0.42	.15	13.3
4.1	$\rho'$ Ophiuchi.....	206	1.13	.15	35.8
0.2	Vega.....	206	0.36	.15	11.4
2.2	$\alpha$ Urs. Min. (Polaris).....	440	0.05	.07	3.4

*Stars which have largest of observed velocities in the line of sight.*

[Extract by the Astronomer Royal from an article in the *Astrophysical Journal* for January, 1901, by W. W. Campbell, director of Lick Observatory.]

Magnitudes.		R. A.		Dec.		Velocity. Kilometer per sec.
		<i>h.</i>	<i>m.</i>	$^{\circ}$	$'$	
4.6	$\epsilon$ Andromedæ.....	0	33	+28	46	-84
	$\mu$ Cassiopeiæ.....	1	0	+54	20	-97
4.2	$\delta$ Leporis.....	5	47	-20	54	+95
	$\theta$ Canis Majoris.....	6	50	-11	55	+96
4.1	$\epsilon$ Pegasi.....	21	17	+19	23	-76
	$\mu$ Sagittarii.....	18	8	-21	1	-76

The + sign denotes recession, the - sign approach.

*Motions of stars in the line of sight determined at Potsdam Observatory, 1889-1891*

[Communicated by Professor Becker, University Observatory, Glasgow.]

Star.	Magni- tude.	Velocity relative to the sun.	Star.	Magni- tude.	Velocity relative to the sun.
		<i>Kilometer.</i>			<i>Kilometer.</i>
α Andromedæ .....	2.0	+ 4.5	γ Leonis .....	2.0	-38.5
β Cassiopeie .....	2.1	+ 5.2	β Ursæ Majoris .....	2.3	-29.3
α Cassiopeie .....	var.	-15.2	α Ursæ Majoris .....	2.	-11.9
γ Cassiopeie .....	2.	- 3.5	δ Leonis .....	2.3	-14.4
β Andromedæ .....	2.3	+11.2	β Leonis .....	2.	-12.2
α Ursæ Minoris .....	2.	-25.9	γ Ursæ Majoris .....	2.3	-26.6
γ Andromedæ .....	2.4	-12.9	ε Ursæ Majoris .....	2.	-30.3
α Arietis .....	2.	-14.7	α Virginis .....	1.	-14.8
β Persei .....	var.	- 1.5	ζ Ursæ Majoris .....	2.1	-31.2
α Persei .....	2.	-10.3	η Ursæ Majoris .....	2.	-26.2
α Tauri .....	1.	+48.5	α Bootis .....	1.	- 7.7
α Aurigæ .....	1.	+24.5	ε Bootis .....	2.	-16.3
β Orionis .....	1.	+16.4	β Ursæ Minoris .....	2.	+14.2
γ Orionis .....	2.	+ 9.2	β Libræ .....	2.	- 9.6
β Tauri .....	2.	+ 8.	α Coronæ .....	2.	+32.
δ Orionis .....	2.5	+ 1.9	α Serpentis .....	2.3	+22.3
ε Orionis .....	2.	+26.5	β Herculis .....	2.3	-35.3
ζ Orionis .....	2.	+14.8	α Ophiuchi .....	2.	+19.2
α Orionis .....	var.	+17.2	α Lyræ .....	1.	-15.3
β Aurigæ .....	2.	-28.1	α Aquilæ .....	1.3	-36.9
γ Geminorum .....	2.3	-16.6	γ Cygni .....	2.4	- 6.4
α Canis Majoris .....	1.	-15.6	α Cygni .....	1.6	- 8.
α Geminorum .....	2.3	-29.7	ε Pegasi .....	2.3	+ 8.
α Canis Minoris .....	1.	- 9.2	β Pegasi .....	var.	+ C.7
β Geminorum .....	1.3	+ 1.1	α Pegasi .....	2.	+ 1.3
α Leonis .....	1.3	- 9.1			

The velocity of the sun relatively to stars in general according to Kempf and Risteen is probably about 19 kms. per second. In respect to greatest proper motions and velocities, Sir Norman Lockyer gives me the following information:

“The star with the greatest known proper motion (across the line of sight) is 243 Cordoba=8".7 per annum. Velocity in kilometers not known.

“1830 Groombridge has a proper motion of 7".0 per annum and a parallax of 0".089, from which it results that the velocity across the line of sight is 370 kms. per second. Various estimates of the parallax, however, have been made, and this velocity is somewhat uncertain. The star with the greatest known velocity in the line of sight is ζ Herculis, which travels at 70 kms. per second.

“The dark line component of Nova Persei was approaching the earth with a velocity of over 1,100 kms. per second.”

This last-mentioned and greatest velocity is probably that of a torrent of gas due to comparatively small particles of melted and evaporating fragments shot out laterally from two great solid or liquid masses colliding with one another, which may be many times greater than the velocity of either before collision; just as we see in the trajectories of small fragments shot out nearly horizontally when a condemned mass of cast iron is broken up by a heavy mass of iron falling upon it from a height of perhaps 20 feet in engineering works.

SEC. 16. Newcomb has given a most interesting speculation regard-

ing the very great velocity of 1830 Groombridge, which he concludes as follows:

“If, then, the star in question belongs to our stellar system, the masses or extent of that system must be many times greater than telescopic observation and astronomical research indicate. We may place the dilemma in a concise form, as follows:

“Either the bodies which compose our universe are vastly more massive and numerous than telescopic examination seems to indicate, or 1830 Groombridge is a runaway star, flying on a boundless course through infinite space with such momentum that the attraction of all the bodies of the universe can never stop it.

“Which of these is the more probable alternative we can not pretend to say. That the star can neither be stopped, nor bent far from its course until it has passed the extreme limit to which the telescope has ever penetrated, we may consider reasonably certain. To do this will require two or three millions of years. Whether it will then be acted on by attractive forces of which science has no knowledge, and thus carried back to where it started, or whether it will continue straight-forward forever, it is impossible to say.

“Much the same dilemma may be applied to the past history of this body. If the velocity of 200 miles or more per second with which it is moving exceeds any that could be produced by the attraction of all the other bodies in the universe, then it must have been flying forward through space from the beginning, and having come from an infinite distance, must be now passing through our system for the first and only time.”

SEC. 17. In all these views the chance of passing another star at some small distance such as one or two or three times the sun's radius has been overlooked; and that this chance is not excessively rare seems proved by the multitude of Novas (collisions and their sequels) known in astronomical history. Suppose, for example, 1830 Groombridge, moving at 370 kms. per second, to chase a star of twenty times the sun's mass, moving nearly in the same direction with a velocity of 50 kms. per second, and to overtake it and pass it as nearly as may be without collision. Its own direction would be nearly reversed and its velocity would be diminished by nearly 100 kms. per second. By two or three such casualties the greater part of its kinetic energy might be given to much larger bodies previously moving with velocities of less than 100 kms. per second. By supposing reversed, the motions of this ideal history, we see that 1830 Groombridge may have had a velocity of less than 100 kms. per second at some remote past time, and may have had its present great velocity produced by several cases of near approach to other bodies of much larger mass than its own, previously moving in directions nearly opposite to its own, and with velocities of less than 100 kms. per second. Still it seems to me quite possible that Newcomb's brilliant suggestion may be true, and that 1830 Groombridge is a roving star which has entered our galaxy, and



This exceedingly small ratio will help us to test an old and celebrated hypothesis that if we could see far enough into space the whole sky would be seen occupied with disks of stars, all of perhaps the same brightness as our own sun, and that the reason why the whole of the night sky and day sky is not as bright as the sun's disk is that light suffers absorption in traveling through space. Remark that if we vary  $r$ , keeping the density of the matter the same,  $N$  varies as the cube of  $r$ . Hence by (10)  $\alpha$  varies simply as  $r$ ; and therefore to make  $\alpha$  even as great as  $3.87/100$ , or, say, the sum of the apparent areas of disks  $\pm$  per cent of the whole sky, the radius must be  $10^{11}.r$ , or  $3.09.10^{27}$  kms. Now, light travels at the rate of 300,000 kms. per second, or  $9.45.10^{12}$  kms. per year. Hence it would take  $3.27.10^{14}$ , or about  $34.10^{14}$ , years to travel from the outlying suns of our great sphere to the center. Now we have irrefragable dynamics proving that the whole life of our sun as a luminary is a very moderate number of million years, probably less than fifty million, possibly between fifty and one hundred. To be very liberal, let us give each of our stars a life of a hundred million years as a luminary. Thus the time taken by light to travel from the outlying stars of our sphere to the center would be about three and a quarter million times the life of a star. Hence if all the stars through our vast sphere commenced shining at the same time, three and a quarter million times the life of a star would pass before the commencement of light reaching the earth from the outlying stars, and at no one instant would light be reaching the earth from more than an excessively small proportion of all the stars. To make the whole sky aglow with the light of all the stars at the same time the commencements of the different stars must be timed earlier and earlier for the more and more distant ones, so that the time of the arrival of the light of every one of them at the earth may fall within the durations of the lights at the earth of all the others! Our supposition of uniform density of distribution is, of course, quite arbitrary, and (sections 13, 15, above) we ought in the greater sphere to assume the density much smaller than in the smaller sphere (5); and, in fact, it seems that there is no possibility of having enough of stars (bright or dark) to make a total of star-disk area more than  $10^{-12}$  or  $10^{-11}$  of the whole sky.

SEC. 20. To understand the sparseness of our ideal distribution of 1,000,000,000 suns divide the total volume of the supposed sphere of radius  $r$  (5) by  $10^9$ , and we find  $123.5.10^{39}$  cu. kms. as the volume per sun. Taking the cube root of this, we find  $4.98.10^{13}$  kms. as the edge of the corresponding cube. Hence if the stars were arranged exactly in cubic order, with our sun at one of the eight corners belonging to eight neighboring cubes, his six nearest neighbors would be each at distance  $4.98.10^{13}$  kms., which is the distance corresponding to parallax  $0''\cdot62$ . Our sun, seen at so great a distance, would probably be



seen as a star of something between the first and second magnitude. For a moment suppose each of our 1,000,000,000 suns, while of the same mass as our own sun, to have just such brightness as to make it a star of the first magnitude at distance corresponding to parallax  $1''\cdot0$ . The brightness at distance  $r$  (5) corresponding to parallax  $0''\cdot001$  would be one one-millionth of this, and the most distant of our assumed stars would be visible through powerful telescopes as stars of the sixteenth magnitude. Newcomb (*Popular Astronomy*, 1883, p. 424) estimated between 30,000,000 and 50,000,000 as the number of stars visible in modern telescopes. Young (*General Astronomy*, p. 448) goes beyond this reckoning and estimates at 100,000,000 the total number of stars visible through the Lick telescope. This is only the tenth of our assumed number. It is nevertheless probable enough that there may be as many as 1,000,000,000 stars within the distance  $r$  (5), but many of them may be extinct and dark, and nine-tenths of them, though not all dark, may be not bright enough to be seen by us at their actual distances.

SEC. 21. I need scarcely repeat that our assumption of equable distribution is perfectly arbitrary. How far from being like the truth is illustrated by Herschel's view of the form of the universe as shown in Newcomb's *Popular Astronomy*, page 469. It is quite certain that the real visible stars within the distance  $r$  (5) from us are very much more crowded in some parts of the whole sphere than in others. It is also certain that instead of being all equally luminous, as we have taken them, they differ largely in this respect from one another. It is also certain that the masses of some are much greater than the masses of others, as will be seen from the following table, which has been compiled for me by Professor Becker from André's *Traité d'Astronomie Stellaire*, showing the sums of the masses of the components of some double stars, and the data from which these have been determined.

	Parallax.	One-half major axis—		Period in years.	M + M' in units of the sun's mass.
		In seconds.	In terms of semimajor axis of earth's orbit.		
	"				
$\alpha$ Centauri.....	0.75	18.17	25	84	2.0
$\beta$ 1 Cygni.....	.14	29.48	68	783	0.5
Sirius.....	.39	8.31	24	52	3.2
Procyon.....	.27	5.84	4	40	6.3
$\sigma^2$ Eridani.....	.19	5.72	28	176	0.9
$\eta$ Cassiopeie.....	.15	8.20	39	190	4.3
$\rho$ Ophiuchi.....	.15	4.60	30	88	3.6
$\gamma$ Virginis.....	.05 <sup>a</sup>	3.99	79 <sup>b</sup>	194	15
$\gamma$ Leonis.....	.02 <sup>a</sup>	1.98	102 <sup>b</sup>	407	6.5

<sup>a</sup> Parallax calculated from dynamical determinations of ratio of semimajor axis of double star's orbit to semimajor axis of earth's orbit.

<sup>b</sup> From spectroscopic observations by Belopolsky of Poulcowa, combined with elements of orbit.

SEC. 22. There may also be a large amount of matter in many stars outside the sphere of  $3.10^{16}$  kilometers radius. but however much matter there may be outside it, it seems to be made highly probable by sections 11-21 that the total quantity of matter within it is greater than 100,000,000 times and less than 2,000,000,000 times the sun's mass.

I wish, in conclusion, to express my thanks to Sir Norman Lockyer, to the Astronomer Royal, Mr. Christie, to Sir Robert Ball, and to Professor Becker for their kindness in taking much trouble to give me information in respect to astronomical data, which has proved most useful to me in sections 11-21, above.

## ON BODIES SMALLER THAN ATOMS.<sup>a</sup>

---

By Prof. J. J. THOMSON,  
*Cambridge University.*

---

The masses of the atoms of the various gases were first investigated about thirty years ago by methods due to Loschmidt, Johnstone, Stoney, and Lord Kelvin. These physicists, using the principles of the kinetic theory of gases and making certain assumptions, which it must be admitted are not entirely satisfactory, as to the shape of the atom, determined the mass of an atom of a gas; and when once the mass of an atom of one substance is known the masses of the atoms of all other substances are easily deduced by well-known chemical considerations. The results of these investigations might be thought not to leave much room for the existence of anything smaller than ordinary atoms, for they showed that in a cubic centimeter of gas at atmospheric pressure and at 0° C. there are about 20 million, million, million ( $2 \times 10^{19}$ ) molecules of gas.

Though some of the arguments used to get this result are open to question, the result itself has been confirmed by considerations of quite a different kind. Thus, Lord Rayleigh has shown that this number of molecules per cubic centimeter gives about the right value for the optical opacity of the air, while a method, which I will now describe, by which we can directly measure the number of molecules in a gas, leads to a result almost identical with that of Loschmidt. This method is founded on Faraday's laws of electrolysis. We deduce from these laws that the current through an electrolyte is carried by the atoms of the electrolyte, and that all these atoms carry the same charge, so that the weight of the atoms required to carry a given quantity of electricity is proportional to the quantity carried. We know, too, by the results of experiments on electrolysis, that to carry the unit charge of electricity requires a collection of atoms of hydrogen which together weigh about one-tenth of a milligram; hence, if we can measure the charge of electricity on an atom of hydrogen we see that one-tenth of this charge will be the weight in milligrams of

---

<sup>a</sup> Reprinted, by permission, from *Popular Science Monthly*, August, 1901.

the atom of hydrogen. This result is for the case when electricity passes through a liquid electrolyte. I will now explain how we can measure the mass of the carriers of electricity required to convey a given charge of electricity through a rarefied gas. In this case the direct methods which are applicable to liquid electrolytes can not be used; but there are other, if more indirect, methods by which we can solve the problem. The first case of conduction of electricity through gases we shall consider is that of the so-called cathode rays, those streamers from the negative electrode in a vacuum tube which produce the well-known green phosphorescence on the glass of the tube. These rays are now known to consist of negatively electrified particles moving with great rapidity. Let us see how we can determine the electric charge carried by a given mass of these particles. We can do this by measuring the effect of electric and magnetic forces on the particles. If these are charged with electricity they ought to be deflected when they are acted on by an electric force. It was some time, however, before such a deflection was observed, and many attempts to obtain this deflection were unsuccessful. The want of success was due to the fact that the rapidly moving electrified particles which constitute the cathode rays make the gas through which they pass a conductor of electricity; the particles are thus, as it were, moving inside conducting tubes which screen them off from an external electric field; by reducing the pressure of the gas inside the tube to such an extent that there was very little gas left to conduct, I was able to get rid of this screening effect and obtain the deflection of the rays by an electrostatic field. The cathode rays are also deflected by a magnet. The force exerted on them by the magnetic field is at right angles to the magnetic force; at right angles also to the velocity of the particle and equal to  $Hev \sin \theta$ , where  $H$  is the magnetic force,  $e$  the charge on the particle, and  $\theta$  the angle between  $H$  and  $v$ . Sir George Stokes showed long ago that if the magnetic force was at right angles to the velocity of the particle the latter would describe a circle whose radius is  $mv/eH$  (if  $m$  is the mass of the particle); we can measure the radius of this circle and thus find  $m/v$ . To find  $v$  let an electric force  $F$  and a magnetic force  $H$  act simultaneously on the particle, the electric and magnetic forces being both at right angles to the path of the particle and also at right angles to each other. Let us adjust these forces so that the effect of the electric force which is equal to  $Fe$  just balances that of the magnetic force which is equal to  $Hev$ ; when this is the case  $Fe = Hev$  or  $v = F/H$ . We can thus find  $v$ , and knowing from the previous experiment the value of  $vm/e$ , we deduce the value of  $m/e$ . The value of  $m/e$  found in this way was about  $10^{-7}$ ; and other methods used by Wiechert, Kaufmann, and Lenard have given results not greatly different. Since  $m/e = 10^{-7}$ , we see that to carry unit charge of electricity by the particles forming the cathode rays only requires a mass

of these particles amounting to one ten-thousandth of a milligram, while to carry the same charge by hydrogen atoms would require a mass of one-tenth of a milligram.<sup>a</sup>

Thus to carry a given charge of electricity by hydrogen atoms requires a mass a thousand times greater than to carry it by the negatively electrified particles which constitute the cathode rays, and it is very significant that, while the mass of atoms required to carry a given charge through a liquid electrolyte depends upon the kind of atom, being, for example, eight times greater for oxygen than for hydrogen atoms, the mass of cathode ray particles required to carry a given charge is quite independent of the gas through which the rays travel and of the nature of the electrode from which they start.

The exceedingly small mass of these particles for a given charge compared with that of the hydrogen atoms might be due either to the mass of each of these particles being very small compared with that of a hydrogen atom or else to the charge carried by each particle being large compared with that carried by the atom of hydrogen. It is therefore essential that we should determine the electric charge carried by one of these particles. The problem is as follows: Suppose in an enclosed space we have a number of electrified particles each carrying the same charge, it is required to find the charge on each particle. It is easy by electrical methods to determine the total quantity of electricity on the collection of particles, and knowing this we can find the charge on each particle if we can count the number of particles. To count these particles the first step is to make them visible. We can do this by availing ourselves of a discovery made by C. T. R. Wilson, working in the Cavendish Laboratory. Wilson has shown that when positively and negatively electrified particles are present in moist dust-free air a cloud is produced when the air is closed by a sudden expansion, though this amount of expansion would be quite insufficient to produce condensation when no electrified particles are present: the water condenses round the electrified particles, and, if these are not too numerous, each particle becomes the nucleus of a little drop of water. Now Sir George Stokes has shown how we can calculate the rate at which a drop of water falls through air if we know the size of the drop, and conversely we can determine the size of the drop by measuring the rate at which it falls through the air: hence by measuring the speed with which the cloud falls we can determine the volume of each little drop, the whole volume of water deposited by cooling the air can easily be

---

<sup>a</sup> Professor Schuster in 1889 was the first to apply the method of the magnetic deflection of the discharge to get a determination of the value of  $m/e$ . He found rather widely separated limiting values for this quantity, and came to the conclusion that it was of the same order as in electrolytic solutions. The result of the method mentioned above, as well as those of Wicelert, Kaufmann, and Lenard, make it very much smaller.

calculated, and dividing the whole volume of water by the volume of one of the drops we get the number of drops, and hence the number of the electrified particles. We saw, however, that if we knew the number of particles we could get the electric charge on each particle; proceeding in this way I found that the charge carried by each particle was about  $6.5 \times 10^{-10}$  electrostatic units of electricity or  $2.17 \times 10^{-20}$  electro-magnetic units. According to the kinetic theory of gases there are  $2 \times 10^{19}$  molecules in a cubic centimeter of gas at atmospheric pressure and at the temperature  $0^\circ \text{C}$ .; as a cubic centimeter of hydrogen weighs about  $1/11$  of a milligram each molecule of hydrogen weighs about  $1/(22 \times 10^{19})$  milligrams, and each atom therefore about  $1/(44 \times 10^{19})$  milligrams, and as we have seen that in the electrolysis of solutions one-tenth of a milligram carries unit charge, the atom of hydrogen will carry a charge equal to  $10/(44 \times 10^{19}) = 2.27 \times 10^{-20}$  electro-magnetic units. The charge on the particles in a gas we have seen is equal to  $2.17 \times 10^{-20}$  units; these numbers are so nearly equal that, considering the difficulties of the experiments, we may feel sure that the charge on one of these gaseous particles is the same as that on an atom of hydrogen in electrolysis. This result has been verified in a different way by Professor Townsend, who used a method by which he found, not the absolute value of the electric charge on a particle, but the ratio of this charge to the charge on an atom of hydrogen, and he found that the two charges were equal.

As the charges on the particle and the hydrogen atom are the same, the fact that the mass of these particles required to carry a given charge of electricity is only one-thousandth part of the mass of the hydrogen atoms shows that the mass of each of these particles is only about one one-thousandth of that of a hydrogen atom. These particles occurred in the cathode rays inside a discharge tube, so that we have obtained from the matter inside such a tube particles having a much smaller mass than that of the atom of hydrogen, the smallest mass hitherto recognized. These negatively electrified particles, which I have called corpuscles, have the same electric charge and the same mass whatever be the nature of the gas inside the tube or whatever the nature of the electrodes; the charge and mass are invariable. They therefore form an invariable constituent of the atoms or molecules of all gases and presumably of all liquids and solids.

Nor are the corpuscles confined to the somewhat inaccessible regions in which cathodic rays are found. I have found that they are given off by incandescent metals, by metals when illuminated by ultra-violet light, while the researches of Becquerel and Professor and Madame Curie have shown that they are given off by that wonderful substance the radio-active radium.

In fact, in every case in which the transport of negative electricity through gas at a low pressure (i. e., when the corpuscles have nothing

to stick to) has been examined, it has been found that the carriers of the negative electricity are these corpuscles of invariable mass.

A very different state of things holds for the positive electricity. The masses of the carriers of positive electricity have been determined for the positive electrification in vacuum tubes by Wien and by Ewers, while I have measured the same thing for the positive electrification produced in a gas by an incandescent wire. The results of these experiments show a remarkable difference between the property of positive and negative electrification, for the positive electricity, instead of being associated with a constant mass one one-thousandth of that of the hydrogen atom, is found to be always connected with a mass which is of the same order as that of an ordinary molecule, and which moreover varies with the nature of the gas in which the electrification is found.

These two results—the invariability and smallness of the mass of the carriers of negative electricity and the variability and comparatively large mass of the carriers of positive electricity—seem to me to point unmistakably to a very definite conception as to the nature of electricity. Do they not obviously suggest that negative electricity consists of these corpuscles, or, to put it the other way, that these corpuscles are negative electricity, and that positive electrification consists in the absence of these corpuscles from ordinary atoms? Thus, this point of view approximates very closely to the old one-fluid theory of Franklin. On that theory electricity was regarded as a fluid, and changes in the state of electrification were regarded as due to the transport of this fluid from one place to another. If we regard Franklin's electric fluid as a collection of negatively electrified corpuscles, the old one-fluid theory will, in many respects, express the results of the new. We have seen that we know a good deal about the "electric fluid;" we know that it is molecular or rather corpuscular in character; we know the mass of each of these corpuscles and the charge of electricity carried by it. We have seen, too, that the velocity with which the corpuscles move can be determined without difficulty. In fact, the electric fluid is much more amenable to experiment than an ordinary gas, and the details of its structure are more easily determined.

Negative electricity (i. e., the electric fluid) has mass. A body negatively electrified has a greater mass than the same body in the neutral state. Positive electrification, on the other hand, since it involves the absence of corpuscles, is accompanied by a diminution in mass.

An interesting question arises as to the nature of the mass of these corpuscles which we may illustrate in the following way. When a charged corpuscle is moving, it produces in the region around it a magnetic field whose strength is proportional to the velocity of the corpuscle; now, in a magnetic field there is an amount of energy pro-

portional to the square of the strength, and thus, in this case, proportional to the square of the velocity of the corpuscle.

Thus, if  $e$  is the electric charge on the corpuscle and  $v$  its velocity, there will be in the region round the corpuscle an amount of energy equal to  $\frac{1}{2} \beta e^2 v^2$  where  $\beta$  is a constant which depends upon the shape and size of the corpuscle. Again, if  $m$  is the mass of the corpuscle its kinetic energy is  $\frac{1}{2} m v^2$ , and thus the total energy due to the moving electrified corpuscle is  $\frac{1}{2} (m + \beta e^2) v^2$ , so that for the same velocity it has the same kinetic energy as a non-electrified body whose mass is greater than that of the electrified body by  $\beta e^2$ . Thus, a charged body possesses in virtue of its charge, as I showed twenty years ago, an apparent mass apart from that arising from the ordinary matter in the body. Thus, in the case of these corpuscles, part of their mass is undoubtedly due to their electrification, and the question arises whether or not the whole of their mass can be accounted for in this way. I have recently made some experiments which were intended to test this point; the principle underlying these experiments was as follows: If the mass of the corpuscle is the ordinary "mechanical" mass, then, if a rapidly moving corpuscle is brought to rest by colliding with a solid obstacle, its kinetic energy being resident in the corpuscle will be spent in heating up the molecules of the obstacle in the neighborhood of the place of collision, and we should expect the mechanical equivalent of the heat produced in the obstacle to be equal to the kinetic energy of the corpuscle. If, on the other hand, the mass of the corpuscle is "electrical," then the kinetic energy is not in the corpuscle itself, but in the medium around it, and, when the corpuscle is stopped, the energy travels outward into space as a pulse confined to a thin shell traveling with the velocity of light. I suggested some time ago that this pulse forms the Röntgen rays which are produced when the corpuscles strike against an obstacle. On this view, the first effect of the collision is to produce Röntgen rays, and thus, unless the obstacle against which the corpuscle strikes absorbs all these rays, the energy of the heat developed in the obstacle will be less than the energy of the corpuscle. Thus, on the view that the mass of the corpuscle is wholly or mainly electrical in its origin, we should expect the heating effect to be smaller when the corpuscles strike against a target permeable by the Röntgen rays given out by the tube in which the corpuscles are produced than when they strike against a target opaque to these rays. I have tested the heating effects produced in permeable and opaque targets, but have never been able to get evidence of any considerable difference between the two cases. The differences actually observed were small compared with the total effect and were sometimes in one direction and sometimes in the opposite. The experiments, therefore, tell against the view that the whole of the mass of a corpuscle is due to its electrical charge. The idea that mass in gen-



eral is electrical in its origin is a fascinating one, although it has not at present been reconciled with the results of experience.

The smallness of these particles marks them out as likely to afford a very valuable means for investigating the details of molecular structure, a structure so fine that even waves of light are on far too large a scale to be suitable for its investigation, as a single wave length extends over a large number of molecules. This anticipation has been fully realized by Lenard's experiments on the obstruction offered to the passage of these corpuscles through different substances. Lenard found that this obstruction depended only upon the density of the substance and not upon its chemical composition or physical state. He found that, if he took plates of different substances of equal areas and of such thicknesses that the masses of all the plates were the same, then, no matter what the plates were made of, whether of insulators or conductors, whether of gases, liquids, or solids, the resistance they offered to the passage of the corpuscles through them was the same. Now, this is exactly what would happen if the atom of the chemical elements were aggregations of a large number of equal particles of equal mass; the mass of an atom being proportional to the number of these particles contained in it and the atom being a collection of such particles through the interstices between which the corpuscle might find its way. Thus, a collision between a corpuscle and an atom would not be so much a collision between the corpuscle and the atom as a whole, as between a corpuscle and the individual particles of which the atom consists; and the number of collisions the corpuscle would make, and therefore the resistance it would experience, would be the same if the number of particles in unit volume were the same, whatever the nature of the atoms might be into which these particles are aggregated. The number of particles in unit volume is, however, fixed by the density of the substance, and thus on this view the density and the density alone should fix the resistance offered by the substance to the motion of a corpuscle through it; this, however, is precisely Lenard's result, which is thus a strong confirmation of the view that the atoms of the elementary substances are made up of simpler parts, all of which are alike. This and similar views of the constitution of matter have often been advocated; thus, in one form of it, known as Prout's hypothesis, all the elements were supposed to be compounds of hydrogen. We know, however, that the mass of the primordial atom must be much less than that of hydrogen. Sir Norman Lockyer has advocated the composite view of the nature of the elements on spectroscopic grounds, but the view has never been more boldly stated than it was long ago by Newton, who says:

“The smallest particles of matter may cohere by the strongest attraction and compose bigger particles of weaker virtue, and many of these may cohere and compose bigger particles whose virtue is still

weaker, and so on for divers succession, until the progression ends in the biggest particles on which the operations in chemistry and the colors of natural bodies depend and which by adhering compose bodies of a sensible magnitude."

The reasoning we used to prove that the resistance to the motion of the corpuscle depends only upon the density is only valid when the sphere of action of one of the particles on a corpuscle does not extend as far as the nearest particle. We shall show later on that the sphere of action of a particle on a corpuscle depends upon the velocity of the corpuscle, the smaller the velocity the greater being the sphere of action, and that if the velocity of the corpuscle falls as low as  $10^7$  centimeters per second, then, from what we know of the charge on the corpuscle and the size of molecules, the sphere of action of the particle might be expected to extend farther than the distance between two particles, and thus for corpuscles moving with this and smaller velocities we should not expect the density law to hold.

#### EXISTENCE OF FREE CORPUSCLES OR NEGATIVE ELECTRICITY IN METALS.

In the cases hitherto described the negatively electrified corpuscles had been obtained by processes which require the bodies from which the corpuscles are liberated to be subjected to somewhat exceptional treatment. Thus in the case of the cathode rays the corpuscles were obtained by means of intense electric fields, in the case of the incandescent wire by great heat, in the case of the cold metal surface by exposing this surface to light. The question arises whether there is not to some extent, even in matter in the ordinary state and free from the action of such agencies, a spontaneous liberation of those corpuscles—a kind of dissociation of the neutral molecules of the substance into positively and negatively electrified parts, of which the latter are the negatively electrified corpuscles.

Let us consider the consequences of some such effect occurring in a metal, the atoms of the metal splitting up into negatively electrified corpuscles and positively electrified atoms, and these again after a time recombining to form neutral system. When things have got into a steady state the number of corpuscles recombining in a given time will be equal to the number liberated in the same time. There will thus be diffused through the metal swarms of these corpuscles; these will be moving about in all directions, like the molecules of a gas, and, as they can gain or lose energy by colliding with the molecule of the metal, we should expect by the kinetic theory of gases that they will acquire such an average velocity that the mean kinetic energy of a corpuscle moving about in the metal is equal to that possessed by a molecule of a gas at the temperature of the metal. This would make the average velocity of the corpuscles at  $0^\circ$  C. about  $10^7$  centimeters per second. This swarm of negatively electrified corpuscles when

exposed to an electric force will be sent drifting along in the direction opposite to the force; this drifting of the corpuscles will be an electric current, so that we could in this way explain the electrical conductivity of metals.

The amount of electricity carried across unit area under a given electric force will depend upon and increase with (1) the number of free corpuscles per unit volume of the metal; (2) the freedom with which these can move under the force between the atoms of the metal. The latter will depend upon the average velocity of these corpuscles, for if they are moving with very great rapidity the electric force will have very little time to act before the corpuscle collides with an atom, and the effect produced by the electric force annulled. Thus the average velocity of drift imparted to the corpuscles by the electric field will diminish as the average velocity of translation, which is fixed by the temperature, increases. As the average velocity of translation increases with the temperature, the corpuscles will move more freely under the action of an electric force at low temperatures than at high, and thus from this cause the electrical conductivity of metals would increase as the temperature diminishes. In a paper presented to the International Congress of Physics at Paris in the autumn of last year, I described a method by which the number of corpuscles per unit volume and the velocity with which they moved under an electric force can be determined. Applying this method to the case of bismuth, it appears that at the temperature of 20° C. there are about as many corpuscles in a cubic centimeter as there are molecules in the same volume of a gas at the same temperature and at a pressure of about one-fourth of an atmosphere, and that the corpuscles under an electric field of 1 volt per centimeter would travel at the rate of about 70 meters per second. Bismuth is at present the only metal for which the data necessary for the application of this method exists, but experiments are in progress at the Cavendish laboratory which it is hoped will furnish the means for applying the method to other metals. We know enough, however, to be sure that the corpuscles in good conductors, such as gold, silver, or copper, must be much more numerous than in bismuth, and that the corpuscular pressure in these metals must amount to many atmospheres. These corpuscles increase the specific heat of a metal and the specific heat gives a superior limit to the number of them in the metal.

An interesting application of this theory is to the conduction of electricity through thin films of metal. Longden has recently shown that when the thickness of the film falls below a certain value the specific resistance of the film increases rapidly as the thickness of the film diminishes. This result is readily explained by this theory of metallic conduction, for when the film gets so thin that its thickness is comparable with the mean free path of a corpuscle the number of col-

lisions made by a corpuscle in a film will be greater than in the metal in bulk, thus the mobility of the particles in the film will be less and the electrical resistance consequently greater.

The corpuscles disseminated through the metal will do more than carry the electric current, they will also carry heat from one part to another of an unequally heated piece of metal. For if the corpuscles in one part of the metal have more kinetic energy than those in another, then, in consequence of the collisions of the corpuscles with each other and with the atoms, the kinetic energy will tend to pass from those places where it is greater to those where it is less, and in this way heat will flow from the hot to the cold parts of the metal. As the rate with which the heat is carried will increase with the number of corpuscles and with their mobility, it will be influenced by the same circumstances as the conduction of electricity, so that good conductors of electricity should also be good conductors of heat. If we calculate the ratio of the thermal to the electric conductivity on the assumption that the whole of the heat is carried by the corpuscles we obtain a value which is of the same order as that found by experiment.

Weber many years ago suggested that the electrical conductivity of metals was due to the motion through them of positively and negatively electrified particles, and this view has recently been greatly extended and developed by Riecke and by Drude. The objection to any electrolytic view of the conduction through metals is that, as in electrolysis, the transport of electricity involves the transport of matter, and no evidence of this has been detected. This objection does not apply to the theory sketched above, as on this view it is the corpuscles which carry the current; these are not atoms of the metal, but very much smaller bodies, which are the same for all metals.

It may be asked, If the corpuscles are disseminated through the metal and moving about in it with an average velocity of about  $10^7$  centimeters per second, how is it that some of them do not escape from the metal into the surrounding air? We must remember, however, that these negatively electrified corpuscles are attracted by the positively electrified atoms, and in all probability by the neutral atoms as well, so that to escape from these attractions and get free a corpuscle would have to possess a definite amount of energy. If a corpuscle had less energy than this, then, even though projected away from the metal, it would fall back into it after traveling a short distance. When the metal is at a high temperature, as in the case of the incandescent wire, or when it is illuminated by ultra-violet light, some of the corpuscles acquire sufficient energy to escape from the metal and produce electrification in the surrounding gas. We might expect, too, that if we could charge a metal so highly with negative electricity that the work done by the electric field on the corpuscle in a distance not greater than the sphere of action of the atoms on the corpuscles was greater than the

energy required for a corpuscle to escape, then the corpuscles would escape and negative electricity stream from the metal. In this case the discharge could be effected without the participation of the gas surrounding the metal, and might even take place in an absolute vacuum, if we could produce such a thing. We have as yet no evidence of this kind of discharge, unless, indeed, some of the interesting results recently obtained by Earhart with very short sparks should be indications of an effect of this kind.

A very interesting case of the spontaneous emission of corpuscles is that of the radio-active substance radium discovered by M. and Mme. Curie. Radium gives out negatively electrified corpuscles which are deflected by a magnet. Becquerel has determined the ratio of the mass to the charge of the radium corpuscles and finds it is the same as for the corpuscles in the cathode rays. The velocity of the radium corpuscles is, however, greater than any that has hitherto been observed for either cathode or Lenard rays; being, as Becquerel found, as much as  $2 \times 10^{10}$  centimeters per second, or two-thirds the velocity of light. This enormous velocity explains why the corpuscles from radium are so very much more penetrating than the corpuscles from cathode or Lenard rays; the difference in this respect is very striking, for while the latter can only penetrate solids when they are beaten out into the thinnest films, the corpuscles from radium have been found by Curie to be able to penetrate a piece of glass 3 millimeters thick. To see how an increase in the velocity can increase the penetrating power, let us take as an illustration of a collision between the corpuscle and the particles of the metal the case of a charged corpuscle moving past an electrified body; a collision may be said to occur between these when the corpuscle comes so close to the charged body that its direction of motion after passing the body differs appreciably from that with which it started. A simple calculation shows that the deflection of the corpuscle will only be considerable when the kinetic energy with which the corpuscle starts on its journey toward the charged body is not large compared with the work done by the electric forces on the corpuscle in its journey to the shortest distance from the charged body. If  $d$  is the shortest distance,  $e$  and  $e'$  the charge of the body and corpuscles, the work done is  $ee'd$ ; while if  $m$  is the mass and  $v$  the velocity with which the corpuscle starts, the kinetic energy to begin with is  $\frac{1}{2}mv^2$ ; thus a considerable deflection of the corpuscle, i. e., a collision, will occur only when  $ee'd$  is comparable with  $\frac{1}{2}mv^2$ ; and  $d$ , the distance at which a collision occurs, will vary inversely as  $v^2$ . As  $d$  is the radius of the sphere of action for collision, and as the number of collisions is proportional to the area of a section of this sphere, the number of collisions is proportional to  $d^2$ , and therefore varies inversely as  $v^4$ . This illustration explains how rapidly the number of collisions, and therefore, the resistance

offered to the motion of the corpuscles through matter diminishes as the velocity of the corpuscles increases, so that we can understand why the rapidly-moving corpuscles from radium are able to penetrate substances which are nearly impermeable to the more slowly moving corpuscles from cathode and Lenard rays.

#### COSMICAL EFFECTS PRODUCED BY CORPUSCLES.

As a very hot metal emits these corpuscles, it does not seem an improbable hypothesis that they are emitted by that very hot body, the sun. Some of the consequences of this hypothesis have been developed by Paulsen, Birkeland, and Arrhenius, who have developed a theory of the aurora borealis from this point of view. Let us suppose that the sun gives out corpuscles which travel out through interplanetary space; some of these will strike the upper regions of the earth's atmosphere, and will then, or even before then, come under the influence of the earth's magnetic field. The corpuscles when in such a field will describe spirals round the lines of magnetic force. As the radii of these spirals will be small, compared with the height of the atmosphere, we may for our present purpose suppose that they travel along the lines of the earth's magnetic force. Thus, the corpuscles which strike the earth's atmosphere near the equatorial regions, where the lines of magnetic force are horizontal, will travel horizontally, and will thus remain at the top of the atmosphere where the density is so small that but little luminosity is caused by the passage of the corpuscles through the gas. As the corpuscles travel into higher latitudes, where the lines of magnetic force dip, they follow these lines and descend into the lower and denser parts of the atmosphere, where they produce luminosity, which, on this view, is the aurora.

As Arrhenius has pointed out, the intensity of the aurora ought to be a maximum at some latitude intermediate between the pole and the equator, for, though in the equatorial regions the rain of corpuscles from the sun is greatest, the earth's magnetic force keeps these in such highly rarefied gas that they produce but little luminosity, while at the pole, where the magnetic force would pull them straight down into the denser air, there are not nearly so many corpuscles; the maximum luminosity will, therefore, be somewhere between these places. Arrhenius has worked out this theory of the aurora very completely, and has shown that it affords a very satisfactory explanation of the various periodic variations to which it is subject.

As a gas becomes a conductor of electricity when corpuscles pass through it, the upper regions of the air will conduct, and when air currents occur in these regions, conducting matter will be driven across the lines of force, due to the earth's magnetic field, electric currents will be induced in the air, and the magnetic force due to these currents will produce variations in the earth's magnetic field. Balfour Stewart

suggested long ago that the variation on the earth's magnetic field was caused by currents in the upper regions of the atmosphere, and Schuster has shown, by the application of Gauss's method, that the seat of these variations is above the surface of the earth.

The negative charge in the earth's atmosphere will not increase indefinitely in consequence of the stream of negatively electrified corpuscles coming into it from the sun, for as soon as it gets negatively electrified it begins to repel negatively electrified corpuscles from the ionized gas in the upper regions of the air, and a state of equilibrium will be reached when the earth has such a negative charge that the corpuscles driven by it from the upper regions of the atmosphere are equal in number to those reaching the earth from the sun. Thus, on this view, interplanetary space is thronged with corpuscular traffic, rapidly moving corpuscles coming out from the sun while more slowly moving ones stream into it.

In the case of a planet which, like the moon, has no atmosphere, there will be no gas for the corpuscles to ionize, and the negative electrification will increase until it is so intense that the repulsion exerted by it on the corpuscles is great enough to prevent them from reaching the surface of the planet.

Arrhenius has suggested that the luminosity of nebulae may not be due to high temperature, but may be produced by the passage through their outer regions of the corpuscles wandering about in space, the gas in the nebulae being quite cold. This view seems in some respects to have advantages over that which supposes the nebulae to be at very high temperatures. These and other illustrations, which might be given did space permit, seem to render it probable that these corpuscles may play an important part in cosmical as well as in terrestrial physics.





# THE EXPLORATION OF THE ATMOSPHERE AT SEA BY MEANS OF KITES.

---

By A. LAWRENCE ROTCH,

*Director of Blue Hill Meteorological Observatory.*

---

The method of obtaining meteorological observations with kites at Blue Hill Observatory has been fully described in appendixes to the Smithsonian Reports for 1897 and 1900, and it will suffice to say, therefore, that during the past seven years several hundred records of the conditions prevailing in the free air have been brought down from an extreme height of 3 miles. These observations have been obtained in almost all weather conditions when the velocity of the wind at the ground was between 12 and 35 miles an hour. Certain types of weather, technically known as anticyclones, and which are characterized by a high barometric pressure and light winds, can therefore rarely be studied aloft, although it is sometimes possible to send up the kites in advance of these conditions and to descend in the central calm area. Often while there is sufficient wind near the ground, it fails entirely at about a mile altitude, near the cumulus clouds, and thus the kites are prevented from rising higher, although at a greater height there is almost always a strong wind. It is usually impossible to launch the kites during the strong gales that attend the coming on and passing off of deep cyclonic disturbances.

As mentioned in my last paper, the United States Weather Bureau undertook during the summer of 1898 to obtain observations with kites simultaneously at a number of places in the central part of the country, but, as the light winds prevented flights from being made regularly at all the stations, the experiment was abandoned. About the same time the employment of kites for meteorological research was taken up on the Continent of Europe, and this work has been most successfully carried out at the private observatory of M. Teisserenc de Bort, near Paris, and at the Aeronautical Observatory of the Royal Prussian Meteorological Institute, near Berlin, which is at the present time the most completely equipped establishment of the kind in the world. The systematic exploration of the atmosphere above the Continent of Europe has been in progress for several years through the

cooperation of an international committee. Balloons with aeronauts and balloons carrying only self-recording instruments to still greater heights ascend on a certain day each month in France, Germany, Austria, and Russia, while kites supply the observations nearer the ground. It frequently happens, however, that on the appointed day the wind at the ground is insufficient to raise the kites, although the balloons drift with the upper currents to great distances.

While, from what precedes, it is evident that the use of kites on land has hitherto been limited to favorable circumstances, yet, by the simple expedient of installing the kites on board a steamship, kites may not only be flown during calms and gales, but also in places above which no observations have been possible heretofore. Except in very bad weather kites can always be flown from either a stationary or a moving ship, since, when the air is calm, by steaming through it at a speed of 10 or 12 knots, the kites can be raised to the height that they would reach in the most favorable natural wind, and, on the contrary, the force of strong winds can be reduced in the same proportion if the vessel moves with the wind. In the case mentioned, when the wind fails at a certain height, the motion of the vessel will suffice to pull the kites through this calm zone and into the stronger upper current that usually suffices to lift them still higher. Thus kites can be flown on board a steamer under almost all conditions, and more easily than on land, since the steadier winds at sea, especially the wind artificially created, facilitate launching them. Steam power is always available to operate the kite winch, and the wire from it may be led over a pulley on a yard-arm capable of being turned so as to bring the kites clear of the rigging, etc. Wherever these observations in the upper air may be made, there is always a station at sea level, and not far distant horizontally, with which to compare them.

To test the practicability of this method of flying kites, experiments were undertaken on August 22, 1901, with the aid of my assistants, Messrs. Fergusson and Sweetland, upon a towboat chartered for this purpose to cruise in Massachusetts Bay. Anticyclonic weather conditions prevailed, and a southeast wind blew from 6 to 10 miles an hour, but at no time with sufficient velocity to elevate the kites, either from sea level or from the adjacent Blue Hill. With the boat moving 10 miles an hour toward the wind, and within an angle of  $45^{\circ}$  on either side of its mean direction, the resultant wind easily lifted the kites and meteorograph, with 3,600 feet of wire, to the height of half a mile. In Plate I, figures 1, 2, and Plate II, figure 3, show, respectively, the meteorograph supported by the kite, a nearer view of the kite, and the hand reel and meteorograph on deck.

While it is desirable to have a vessel that can be started, stopped, and turned at the will of the meteorologist, as was the case in the experiments described, it seemed nevertheless probable that soundings



FIG. 1.—METEOROGRAPH LIFTED BY A KITE.



FIG. 2.—HARGRAVE KITE IN THE AIR.



of the atmosphere could often be made from a steamship pursuing its regular course, and accordingly such were attempted on a steamer eastward bound across the North Atlantic. With the aid of my assistant, Mr. Sweetland, and through the courtesy of Captain McAuley, this was accomplished on board the Dominion steamship *Commonwealth*, which left Boston for Liverpool on August 28, 1901. A view of the stern of the ship, with the upper deck from which the kites were flown is shown in Plate II, figure 4. During most of the voyage we were within an area of high barometric pressure that was drifting slowly southeastward and out of which light winds blew. Although these were insufficient to raise the kites, the ship's speed of 16 knots created a corresponding wind from an easterly direction that sufficed to lift the kites on five of the eight days occupied by the voyage to Queenstown. On one of the three unfavorable days, a following wind became too light on the ship for kiteflying, and on the two other days a fresh head wind, augmented by the forward motion of the ship, was so strong as to endanger the kites, but had it been possible to alter the course of the vessel a favorable resultant wind might have been produced every day. The maximum height attained was only about 2,000 feet, but with larger kites and longer wire this could have been greatly exceeded. Automatic records were obtained of barometric pressure, air temperature, relative humidity, and wind velocity, which did not differ markedly from records obtained in somewhat analogous weather conditions over the land. The most striking feature was the rapid decrease of the temperature with increasing height in all but one of the flights. The fall of temperature was fastest in the first 300 feet, where it exceeded the adiabatic rate of  $1^{\circ}$  F. in 183 feet, but in the last-mentioned flight the temperature rose  $6^{\circ}$  in 450 feet, and during the afternoon remained so much warmer than at sea level. The relative humidity varied inversely with the temperature, the direction of the wind shifted aloft toward the right hand when facing it, and its velocity generally increased with increase of altitude. The direction and velocity of the wind aloft were computed from the observed position of the kite and the recorded velocity of the wind at this level, allowing for the speed at which the kite was being dragged through the air by the vessel. Simultaneous records were obtained from a meteorograph hung above the deck, with which the upper-air records were compared.

These are probably the first meteorological observations at a considerable height in mid-Atlantic, and have a special importance, because they indicate that at sea high-level observations may be obtained with kites in all weather conditions, only excepting severe gales, provided the steamer from which the kites are flown can be so maneuvered as to bring the wind to a suitable velocity. It is evident that such observations as have been described, even if made like the preceding, only

when the conditions were favorable, would go far toward showing whether the conditions prevailing over the ocean differ from those above the land, and would also furnish information about the upper air in atmospheric situations that can not be explored with kites at a fixed station. So far as known, meteorological records had not been obtained before last summer from kites flown from a moving vessel, although during the first half of the last century registering thermometers were lifted by kites several hundred feet above the Arctic ocean, when the vessel was fast in the ice. The German Antarctic vessel *Gauss* and the *Discovery* of the English Antarctic expedition are each equipped with meteorological kites, which were to be used on the Southern voyages commenced in August, 1901, but it is to be feared that this branch of the meteorological work, being subordinate to the main aims of the expeditions, will always be sacrificed to them. In any case, it must be remembered that scientific kiteflying demands practiced and skillful operators, and without them and much reserve apparatus must yield mediocre results. To make these observations properly requires that the vessel be completely under the control of the meteorologist, who may then explore the heights of the atmosphere, just as the hydrographer and zoologist have explored the depths of the ocean. Had the British *Challenger* expedition been provided with our modern kite apparatus and accompanied by meteorologists trained in their use, it might have accomplished the double task of sounding the oceans of air and water.

Although observations above all the oceans are valuable, the exploration of the equatorial region is the most important, since, with the exception of a few observations on the Andes and on mountains in central Africa, we know nothing of the thermal conditions existing a mile or two above the equator, and only what the clouds tell us of the currents in which they float. The need of such data to complete our theories of the thermodynamics of the atmosphere was urged by Professor Woeikof, of St. Petersburg, at the Meteorological Congress of 1900 in Paris. North and south of the equator, within the trade-wind belts, kites might be employed to determine the height to which the trades extend, and also the direction and strength of the upper winds, concerning which the high clouds, rarely seen in those latitudes, furnish our only information. Professor Hildebrandsson, of Upsala, who is an eminent authority on the circulation of the atmosphere, believes that a meteorologist on a steamship provided with kites, and also with small balloons to ascertain the drift of the upper winds when there are no clouds, by making atmospheric soundings between the area of high barometric pressure in the North Atlantic and the constant southeast trades south of the equator, and in this way investigating the temperature and flow of the so-called anti-trades above the surface winds, could solve in three months one of the most important problems in



FIG. 3.—KITE REEL AND METEOROGRAPH ON DECK.



FIG. 4.—S. S. COMMONWEALTH LEAVING BOSTON.





meteorology. The two Antarctic vessels already mentioned are unlikely for several reasons, but chiefly because they generally proceeded under sail, to have contributed important data concerning the upper air in their voyages across the equator. Although the United States has taken no part in this international Antarctic campaign, an opportunity is offered, during the next year or two, without material expense, danger, or hardship, to cooperate in a study of the general atmospheric circulation, which is one of the objects of polar exploration. Indeed, for a naval vessel not actually engaged otherwise, the sounding of the atmosphere in the tropics, whereby the relation of the upper-air currents to the winds useful for navigation may be ascertained, would seem to be as legitimate a task as sounding the depths of the oceans and determining the currents and temperatures prevailing there. But if our Navy Department will not authorize this, a private expedition should be organized to investigate the questions mentioned, which are of prime importance for meteorology and physical geography.



## SOLID HYDROGEN.<sup>a</sup>

By JAMES DEWAR, F. R. S.

Before proceeding to discuss the immediate subject of this lecture it will be advisable to contrast experimentally some of the properties of hydrogen, nitrogen, and oxygen in the liquid condition. The two vacuum cups (figs. 1 and 2) are charged half full, respectively, with liquid hydrogen and liquid air. When the cup containing the liquid air is placed in front of the electric lamp the image thrown on the screen reveals the continual overflow of a dense vapor round the outer

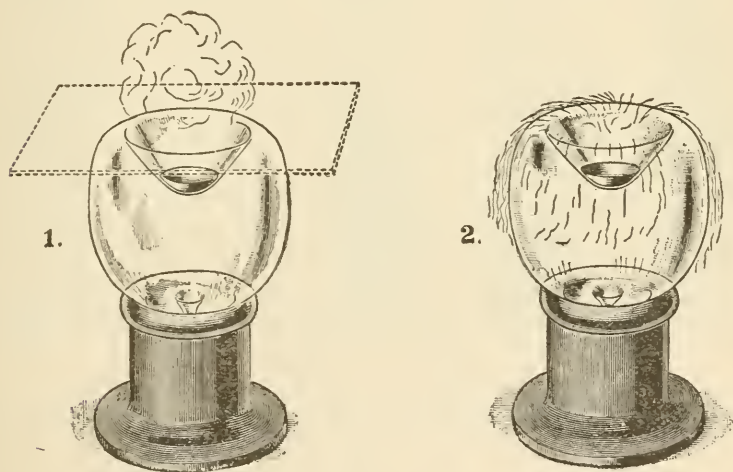

walls of the vessel. The saturated vapor coming from the steady ebullition of liquid air is three times denser than the free air of the room, and the result is it falls through that air just as if it were a dense gas, like carbonic acid or ether vapor. To observe this phenomenon, the vacuum cup must be shallow; otherwise the vapor gets heated up before reaching the mouth of the vessel, and no difference of density in the air coming off is observed. We will now project the

<sup>a</sup> Reprinted from Proceedings of Royal Institution of Great Britain, 1900. Read at meeting of Royal Institution, April 6, 1900.

image of the cup containing liquid hydrogen, covered loosely in this case with a glass plate, upon the screen; here no heavy vapor escaping round the sides is visible. The vapor of the boiling liquid hydrogen has a density nearly equal to the air of the room, but as it gets very rapidly heated up by the glass cover the gas that is escaping is seen to rise in air like any light gas. On now removing the glass plate a very different phenomenon is observed, which contrasts markedly with the behavior of the liquid air in the former vessel. The cup and the air above is filled with a dense surging snowstorm of solid air; the air, coming in contact with the excessively cold hydrogen vapor, is suddenly solidified, and a part of it falls into the liquid hydrogen, causing more rapid evaporation, thereby intensifying the cloud condensation. After the mist has disappeared and all the liquid hydrogen gone the cup contains a white deposit of solid air. This shortly melts, and on allowing the nitrogen to boil off, the presence of oxygen can be shown by the ignition of a red-hot splinter of wood. Such effects are easily understood when we remember that the boiling point of hydrogen is proportionally as much below the boiling point of air as the latter is below the ordinary temperature of this room.

In order to observe the individual behavior of the constituents of the air at temperatures below their ordinary boiling points, it is advantageous to place liquid nitrogen and oxygen in separate vacuum vessels, so connected that they may be simultaneously exhausted, as is represented in fig. 4. On starting the air pump both liquids enter into rapid ebullition. As the exhaustion gets higher the temperature of each liquid gets lower and lower, and if the melting point is finally reached in either liquid it must shortly begin to solidify. This condition is quickly brought about in the case of the vessel A, containing the liquid nitrogen, which passes rapidly into the condition of a dense white snow; but no amount of time spent in maintaining a good exhaustion (5 to 10 millimeters pressure) has any effect in changing the liquid condition of the oxygen in B. Oxygen in fact remains liquid at temperatures where nitrogen is solid. The snow of solid air produced by the evaporation of liquid hydrogen in the previous experiment might thus be made up of solid nitrogen and a liquid rain of oxygen. To show that the temperature of boiling hydrogen solidifies oxygen, some of the latter liquid is placed in a vacuum test tube O (fig. 3) and liquid hydrogen H is poured on its surface, when the liquid oxygen is quickly transformed into a clear blue solid ice. Both oxygen and nitrogen, and we shall see later hydrogen, can be changed into the condition of transparent ice as well as into the snowy state. A closed vessel filled with any gas at atmospheric pressure, of such a form that a portion of the surface in the shape of a narrow quill tube, can be cooled in boiling liquid hydrogen like B, fig. 5, shows condensation of the gas to the solid state, the only exceptions being helium and hydro-

gen itself. Here are two vessels of the same shape as A, B, fig. 5. The first contains helium, showing no condensation when the part B is cooled; the second is filled with hydrogen, which equally shows no change of state under the conditions of the experiment. It is easy, however, to make the hydrogen vessel show liquefaction. For this purpose the experiment with the hydrogen is repeated, only before doing so the part A is heated to about  $300^{\circ}\text{C}$ . over a Bunsen burner, in order to increase the pressure of gas in the interior to above two

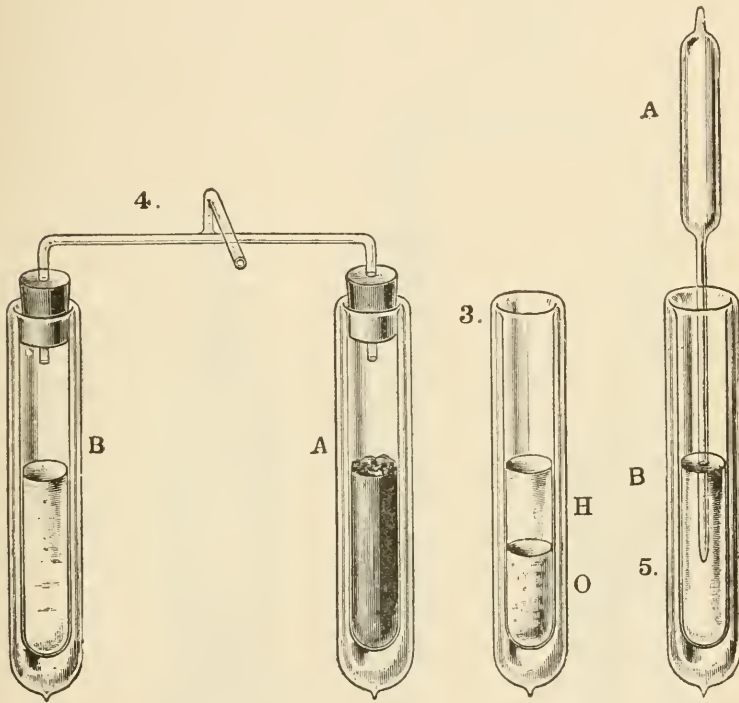

atmospheres. Now, liquefaction is seen to take place with great facility. No change is produced by similarly increasing the pressure in the helium vessel.

The extraordinary command liquid hydrogen gives us over the transition of state in matter may be best illustrated by the use of a new kind of cryophorus. Wollaston's celebrated instrument operates by forcing the evaporation of water in a closed vessel by condensing its vapor in a part of the receiver at a distance from the fluid, thereby causing a lowering of temperature in the latter until freezing takes place. Hence, the name cryophorus or cold-bearer. Instead of using water we may now show that the same principle may be applied to the solidification of nitrogen at a distance instead of water. The sole difference in this case is that the liquid nitrogen must be isolated from

the influx of heat by being placed in a vacuum vessel, and the condensation of its vapor must be effected by the use of liquid hydrogen.

No boiling-out operation is necessary with the cryophorous we are about to use. The apparatus is shown in fig. 6. The vacuum tube B contains liquid nitrogen. It is fitted on by an india rubber joint to a wide piece of glass tubing doubly bent at right angles, A D; and in order to allow the gas from the boiling liquid to escape before the

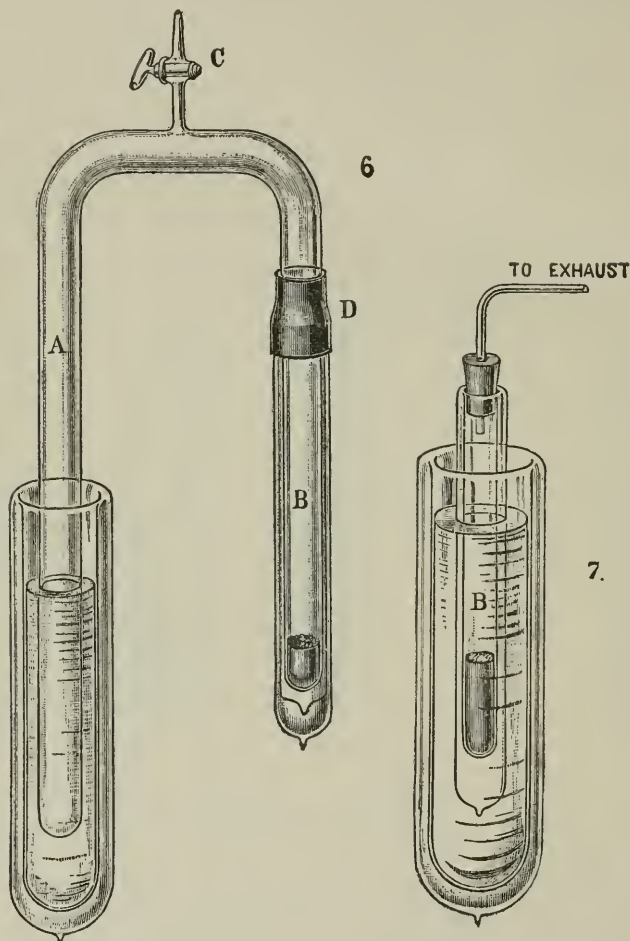

experiment begins, an aperture, C, is left which can be closed with a stopcock. On closing C and inserting a part of the tube A into a vessel containing liquid hydrogen, the gas within is condensed, and thereby the pressure of the vapor in the interior of the vessel is reduced, forcing the liquid nitrogen in the other part of the apparatus to boil with great violence. In a few minutes the temperature of the nitrogen is so much reduced that it passes into the solid state. Many

other liquid gases might be used to replace the nitrogen in this experiment. In making a selection, however, it is necessary to take only those bodies that possess a reasonably high tension of vapor at the melting point. The process would not succeed easily with a substance like oxygen, that has no measurable tension of vapor in the solid condition.

In the autumn of 1898, after the production of liquid hydrogen was possible on a small scale, its solidification was attempted by boiling under reduced pressure. At this time, to make the isolation of the hydrogen as effective as possible, the liquid was placed in a small vacuum test-tube, placed in a larger vessel of the same kind. Excess of hydrogen partly filled the annular space between the two vacuum vessels. On diminishing the pressure by exhaustion the evaporation was mainly thrown on the liquid hydrogen in the annular space between the tubes. In this arrangement the outside surface of the smaller tube was kept at the same temperature as the inside, so that the liquid hydrogen for the time was effectually guarded from influx of heat. With such a combination the liquid hydrogen was evaporated under diminished pressure, yet no solidification took place. Seeing experiments of this kind required a large supply of the liquid, other problems were attacked, and further attempts in the direction of producing the solid for the time abandoned. During the course of the present year many varieties of electric resistance thermometers have been under observation, and with some of these the reduction of temperature brought about by exhaustion was investigated. Thermometers constructed of platinum and platinum-rhodium (alloy) were only lowered  $1\frac{1}{2}^{\circ}$  C. by exhaustion of the liquid hydrogen, and they all gave a boiling-point of  $-245^{\circ}$  C., whereas the reduction in temperature by evaporation in vacuo ought to be  $5^{\circ}$  C., and the true boiling-point from  $-252^{\circ}$  C. to  $-253^{\circ}$  C. In the course of these experiments it was noted that almost invariably a slight leak of air occurred which became apparent by its being frozen into an air-snow in the interior of the vessel, where it met the cold vapor of hydrogen. When conducting wires covered with silk have to pass through india rubber corks, it is very difficult at these excessively low temperatures to prevent leaks, when corks get as hard as a stone and cements crack in all directions. The effect of this slight air leak on the liquid hydrogen when the pressure got reduced below 60 millimeters was very remarkable, as it suddenly solidified into a white froth-like mass like frozen foam. My first notion was that this body might be a sponge of solid air containing liquid hydrogen. The ordinary solid air obtained by evaporation in vacuo is a magma of solid nitrogen containing liquid oxygen. The fact, however, that this white solid froth evaporated completely at the low pressure without leaving any substantial amount of solid air led to the conclusion that the body after all must be solid

hydrogen. This surmise was confirmed by observing that if the pressure, and therefore the temperature, of the hydrogen was allowed to rise, the solid melted when the pressure reached about 55 millimeters. The failure of the early experiment must then have been due to supercooling of the liquid, which presumably is prevented by contact with metallic wires and traces of solid air. On the other hand, it is possible the pressure under which the ebullition took place might never have been low enough to reach the solid state.

For the lecture demonstration of solid hydrogen the apparatus may be most conveniently arranged as is shown in fig. 7. The small vacuum tube B, after being filled with liquid hydrogen, is immersed in a larger vessel of the same kind filled with liquid air. By this arrangement the rate of the liquid hydrogen evaporation is so much diminished that it does not exceed that of liquid air in the same vessel when used in the ordinary way. On gradually applying exhaustion to the liquid hydrogen it is forced from its effective heat isolation to pass to a lower temperature, and when the exhaustion reaches 50 millimeters the mass suddenly begins to solidify into a froth-like material. In order to ascertain the appearance of the hydrogen, made by cooling the liquid produced in a hermetically closed vessel, the following experiment was arranged. A flask about a liter capacity, to which a long glass tube was sealed, A, B, fig. 5, was filled with pure dry hydrogen and sealed off. The lower portion B of this tube was calibrated. It was surrounded with liquid hydrogen placed in a vacuum vessel arranged for exhaustion. As soon as the pressure of the boiling hydrogen got well reduced below that of the atmosphere, perfectly clear liquid hydrogen began to collect in the tube B, and could be observed accumulating until the liquid hydrogen surrounding the outside of the tube suddenly passed into a solid white foam-like mass, almost filling the whole space. As it was not possible to see the condition of the hydrogen in the interior of the tube B when it was covered with a large quantity of this solid, the whole apparatus was turned upside down in order to see whether any liquid would run down from B into the flask A. Liquid did not flow down the tube, so the liquid hydrogen with which the tube was partly filled must have solidified. By placing a strong light on the side of the vacuum test tube opposite the eye, and maintaining the exhaustion at about 25 millimeters gradually the hydrogen froth became less opaque, and the solid hydrogen in the tube B was seen to be a transparent ice, but the surface looked frothy. This fact prevented the solid density from being determined, but the maximum fluid density has been approximately ascertained. This was found to be 0.086, the liquid at its boiling point having the density 0.07. The solid hydrogen melts when the pressure of the saturated vapor reaches about 55 millimeters. In order to determine the temperature of solidification two constant volume hydrogen thermometers were used. One at  $0^{\circ}$  C.



contained hydrogen under a pressure of 269.8 millimeters, and the other under a pressure of 127 millimeters. The mean temperature of the solid was found to be  $16^\circ$  absolute under a pressure of 35 millimeters. All the attempts made to get an accurate electric resistance thermometer for such low temperature observations have been so far unsatisfactory. Now that pure helium is definitely proved to be more volatile than hydrogen, this body, after passing through a spiral glass tube immersed in solid hydrogen to separate all other gases, must be compared with the hydrogen thermometer. Taking the boiling point as  $21^\circ$  absolute under 760 millimeters, and the similar value under 35 millimeters is  $16^\circ$  absolute, then the following approximate formula for the vapor tension of liquid hydrogen below one atmosphere is derived:

$$\log p = 6.7341 - 83.28/T \text{ mm.},$$

where  $T$  is the absolute temperature, and  $p$  the pressure in millimeters. This formula gives for 55 mm. a temperature of  $16.7^\circ$  absolute. The melting point of hydrogen must therefore be about  $16^\circ$  or  $17^\circ$  absolute. It has to be noted that the pressure in the constant volume hydrogen thermometer, used to determine the temperature of solid hydrogen boiling under 35 mm., had been so far reduced that the measurements were made under from one-half to one-fourth the saturation pressure for the temperature. When the same thermometers were used to determine the boiling point of hydrogen at atmospheric pressure, the internal gas pressure was only reduced to one-thirteenth the saturation pressure for the temperatures. The absolute accuracy of the boiling points under diminished pressure must be examined in some future paper. The practical limit of temperature we can command by the evaporation of solid hydrogen is from  $14^\circ$  to  $15^\circ$  absolute. In passing it may be noted that the critical temperature of hydrogen being  $30^\circ$  to  $32^\circ$  absolute the melting point is about half the critical temperature. The melting point of nitrogen is also about half its critical temperature. The foam-like appearance of the solid, when produced in an ordinary vacuum vessel, is due to the small density of the liquid and the fact that rapid ebullition is substantially taking place in the whole mass of liquid. The last doubt as to the possibility of solid hydrogen having a metallic character has been removed and for the future hydrogen must be classed among the nonmetallic elements.

All solid bodies by themselves make very unsatisfactory cooling agents unless we can use them to cool some liquid. Now, with solid hydrogen we can cool no liquid other than hydrogen, so that, for effective cooling we must use the liquid just above its freezing point, which is about  $16^\circ$ . It will, however, take a long time to exhaust the wide field of investigation which the use of liquid hydrogen opens up, so we may proceed to illustrate some of its further applications. In

former lectures the relation of electrical resistance to temperature has been discussed, and it was experimentally demonstrated that the curves of resistance of the pure metals all pointed to this quality disappear-

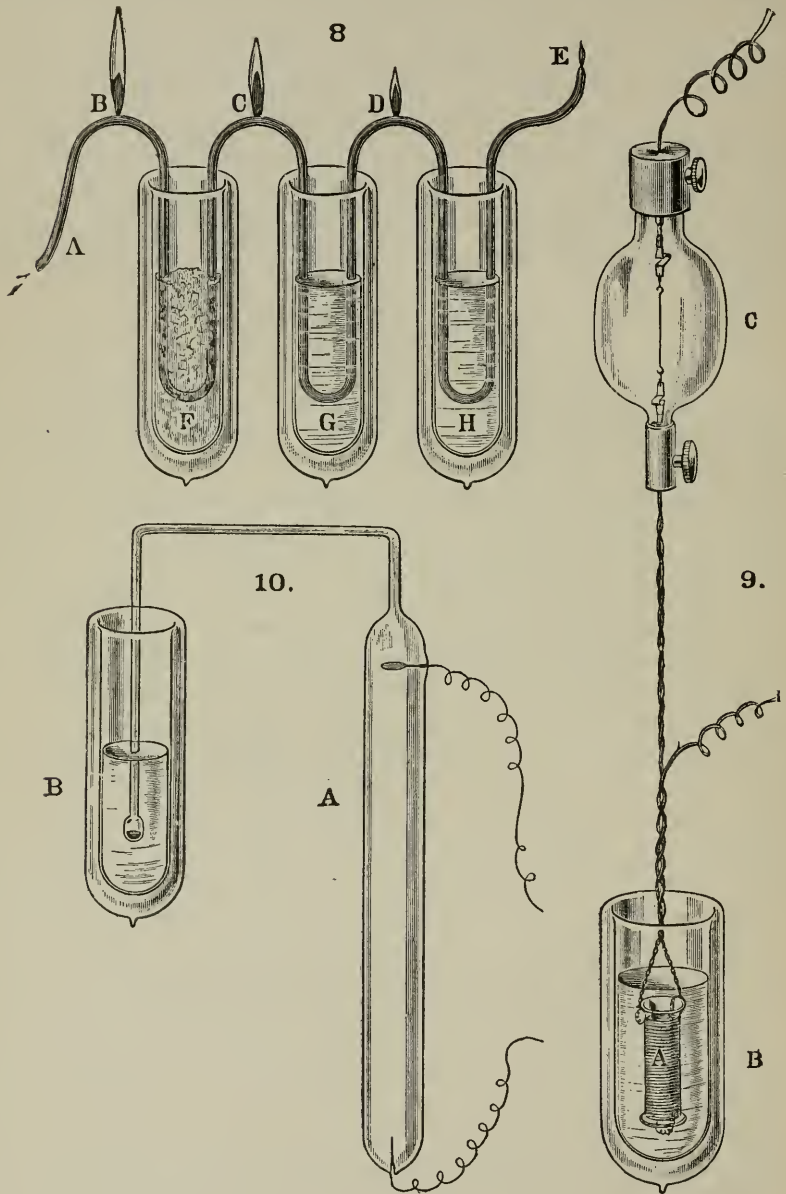

ing or becoming exceeding small at the absolute zero. This fact has been confirmed, even with the most highly conducting metals, down to the lowest temperature we can command. The experiment illustrated in fig. 9 shows to an audience the diminution of resistance of

pure copper wire when cooled in liquid hydrogen in contrast to liquid air. An incandescent lamp C has been placed in circuit with a fine coil of copper wire A, immersed in liquid air, the resistances being so adjusted that the filament in C is just visible when the current passes under these conditions. Now, on removing the coil from the liquid-air vessel and placing it in another similar vessel filled with liquid hydrogen, a great increase in the brilliancy of the lamp is observed. As a matter of fact, the sample of copper has its resistance in liquid air reduced to about one-twentieth of what it is at the temperature of melting ice, whereas in liquid hydrogen the resistance is reduced to one-hundredth of the same amount. In other words, the resistance in liquid hydrogen is only about one-fifth of what it is in liquid air. The interesting point, however, is that theoretically we should infer, from experiments made at higher temperatures, that at a temperature of  $-223^{\circ}$  C. the copper should have no resistance or it should have become a perfect conductor. As this is not the case, even at the temperature of  $-253^{\circ}$ , we must infer that the curve correlating resistance and temperature tends to become asymptotic at the lowest temperatures.

Liquid hydrogen is a most useful agent for the production of high vacua and for the separation of gases from air that may be more volatile than oxygen or nitrogen. An experiment illustrating the production of a high vacuum is shown in fig. 10, where A is the large electric discharging tube, to which has been attached a narrow glass tube twice bent at right angles and terminating in a bulb at the end for immersion in the liquid hydrogen. The rapidity with which the vacuum is attained is shown by the rate at which the striation in the tube changes and the phosphorescent state supervenes. Another rough illustration of the application of cold to effect the separation of a complex mixture of gases is shown in fig. 8. Coal gas is passed in succession through the U-tubes F, G, and H, made of ordinary gas-pipe, having small holes at B, C, D, and E, in order that a flame may be produced before and after each vessel is passed. Each of the U-tubes is placed in a vacuum vessel, and the first cooling substance the gas in its transit meets is solid carbonic acid in F, then liquid air in G, and finally liquid hydrogen in H. At the temperature of the carbonic-acid bath all the easily condensable hydrocarbons separate, and consequently the flame C is less luminous than B. The liquid-air bath condenses the ethylene and a large part of the marsh gas and allows the carbonic oxide and the hydrogen to pass through, so that flame D is less luminous than C. Finally, after the liquid-hydrogen bath, nothing escapes condensation but free hydrogen, the carbonic oxide and any marsh gas being solidified; the result is, the flame E is almost invisible.

A really practical application of liquid hydrogen is the purification of helium obtained from the gases emitted by the mineral springs of Bath. Although the helium only amounts to one-thousandth part by

volume—the nine hundred and ninety-nine being chiefly nitrogen—yet the low temperature method of separation can be successfully applied.

Now that we know definitely the approximate values of some of the more important physical constants of liquid hydrogen, it is interesting to look back at the values that have been deduced—say for such a constant as the density—by various workers using entirely different methods. The following table gives some of the more important values of the density of hydrogen under the different conditions in which it enters into organic and inorganic bodies:

*Density of hydrogen in different conditions.*

Kopp.....	Organic bodies .....	0.18
Amagat.....	Limit of gaseous compression .....	0.12
Wroblewski ....	Van der Waals's equation (critical density) .....	0.027
Van der Waals..	Superior limit of density.....	0.82
Graham .....	Palladium alloy .....	2.0
Dewar.....	Palladium alloy .....	0.63
Dewar.....	Liquid hydrogen at boiling point .....	0.07

My density at the boiling point agrees substantially with that which can be deduced from Wroblewski's form of the Van der Waals equation. The deduced densities of Kopp for organic bodies and Amagat for gaseous compression are both about the same value, and may be taken as a mean to be twice the observed density of hydrogen in the liquid state. The conclusions of Graham and myself touching the density of the hydrogen in the so-called alloy of palladium, must be regarded as altogether exceptional. Even my value would exceed the density of the stuff constituting the real gas molecule, according to the theory of Van der Waals. In order to harmonize the palladium hydrogen results with those deduced from the study of organic bodies, we must assume that, during the formation of the so-called hydrogenium, a condensation of the palladium sufficient to increase its density by one-fifth must take place. This is by no means an unreasonable hypothesis. The mode of determining the density of hydrogen at its melting point has been previously described, and found to be 0.086. In the same way the approximate values for the densities of nitrogen and oxygen at their melting points have been found, their respective values being 1.07 and 1.27. The following table shows the comparison between my results and those given by Amagat for high gaseous compressions:

*Densities.*

	Liquid melting point.	Gas, 3,000 atmospheres.	Limiting value 4,000 atmospheres.
Hydrogen .....	0.086	0.097	0.12
Nitrogen .....	1.1	0.833	0.12
Oxygen.....	1.27	1.127	1.25

It will be noted that the density of gaseous hydrogen at 3,000 atmospheres is actually greater than the maximum density of the liquid state, but neither in the case of nitrogen nor oxygen does the density at the same pressure reach the fluid density. Amagat's limiting value for oxygen under 4,000 atmospheres would, however, be almost identical with mine.

During the course of my inquiries sufficient data have been accumulated to construct Waterston formulæ giving the approximate densities of liquid hydrogen, nitrogen, and oxygen in each case through a wide range of temperature. The equation for each substance is given in the following table:

*Liquid atomic volumes.*

$$\begin{aligned} \text{Hydrogen} &= 23.3 - 8.64 \log (32^\circ - t) \\ \text{Nitrogen} &= 30.0 - 11.00 \log (127^\circ - t) \\ \text{Oxygen} &= 32.6 - 10.22 \log (155^\circ - t) \end{aligned}$$

	Absolute zero.	Observed at melting point.
1. Atomic volume of hydrogen	} = 10.3	11.7
2. Atomic volume of hydrogen		
3. Atomic volume of nitrogen	= 12.8	13.1
4. Atomic volume of oxygen	= 10.20	12.6

From these formulæ we find the respective hypothetical atomic volumes of hydrogen, nitrogen, and oxygen at the absolute zero to be 10.3, 12.8, and 10.2. My observed minimum fluid values were 11.7, 13.1, and 12.6. The coefficients of expansion of the liquids, taken in the same order at their respective boiling points, are 0.024, 0.0056, and 0.0046. Thus liquid hydrogen had a coefficient of expansion five times greater than that of liquid oxygen. Further inquiry will enable the constants in these equations to be determined with greater accuracy. In the meantime, however, they give us general ideas of the order of magnitude of the quantities involved.

I have to thank Mr. Robert Lennox for efficient aid in the arrangement and execution of the difficult experiments you have witnessed. Mr. Heath has also heartily assisted in the preparations.



## UTILIZING THE SUN'S ENERGY.<sup>a</sup>

By ROBERT H. THURSTON, LL. D., Dr. Eng.,

*Director of Sibley College, Cornell University.*

Men of science, familiar with the resources of our globe in the domain of power production and utilization, and especially all who have considered the origin, extent, and rate of extinction of the quantities of energy available for the purposes of civilized humanity, have, for many years, concerned themselves seriously with the question, "When and how shall we reach and pass the critical period at which the stores of now available latent energy of fossil fuel shall have become exhausted?"

While this problem is not immediately pressing, it can not be long, time being gauged by the periods of the historian—it is still more limited in the view of the geologist—before our stock of coal will be so far depleted as to make serious trouble in our whole social system. Professor Leslie, when State geologist of Pennsylvania, and the late Mr. Eckley B. Cox, estimated the probable life of the coal supplies of that State, at the present rate of consumption and acceleration, to be something like a century, and the close of the twentieth century will be very likely to see an end of such manufactures in that State as depend upon cheap fuel and proximity to the coal deposits. In Great Britain the case is probably vastly more serious than in the United States, for there the coal beds are far more restricted in area, and in many localities are already extensively depleted, with prices rising as a consequence. The same is to be said, in perhaps somewhat less degree, of the fuels of the continent of Europe—and France, and particularly Germany, may ere long feel the effect of a stringency in the fuel market.

Enormous deposits of coal remain untouched in other sections of the globe, and China can probably supply the world for many years; but a time must come, and that within a few generations at most, when some other energy than that of combustion of fuel must be relied upon to do a fair share of the work of the civilized world, and this will probably by that time mean the whole of the world.

Water power, which is the next most important source of energy in

<sup>a</sup> Reprinted, by permission, from *Cassier's Magazine*, New York, August, 1901.

manufactures, will do much for us, and that will last as long as humanity survives on this globe; but it is doubtful whether it can be considered as a possible complete substitute for steam power. Yet the total available water power of the world will greatly ameliorate the difficulties likely to arise from extinction of fuel supplies. The mean annual rainfall of the world is 36 inches, and this means about 50,000,000 cubic feet per square mile per annum falling on the land of both hemispheres. Taking the mean available height of fall as 10 feet, and assuming it possible to store the water effectively in ample reservoirs, this would mean  $50,000,000 \times 60 = 30,000,000,000$  foot-pounds of available energy, and, if expended in three thousand working hours, it would give a total of 10,000,000 horsepower per square mile for such countries as might be able to utilize such a fall. This, however, is but a small fraction of the inhabited area of the globe. As a fair estimate, the data for the Mississippi River, in the United States, may be taken. This stream drains about 1,250,000 square miles, with a rainfall of 30 inches, an average, for each foot of fall, of 11,000,000,000,000 foot-pounds per annum. The fall is 6 inches per mile, average, and the energy capable of use for that area is about a quarter of a million horsepower per square mile.

These figures are enormous, and give the impression that we need not feel uneasy about our power supply, even though we entirely extinguish our fuel deposits. They are, however, of little value; for they give no idea of the practically available energy of rainfall, since it is not possible to make use of more than a minute fraction of this total, and it is not at all probable that we ever can. In the whole length of the Mississippi River there are but three available water powers—one with 78 feet fall, at Minneapolis, one with 24 feet, at Des Moines, and one with 22 feet, at Rock Island. Taking the average flow as a half million cubic feet per second utilized, the water powers at these points would be a total of about 7,000,000 horsepower derived from an area of a million and a quarter square miles, and directly from but a fraction of that area, situated above the lowest fall.

The deduction must evidently be that water power alone can not be depended upon to provide the energy that will be needed by future generations should fuel be unavailable, although it is equally obvious that streams are likely to provide immense quantities of power, and that manufactures in those coming days will group themselves about the mill sites or within distances from them which can be spanned by the electric high-tension wire. Of this process of displacement of manufactures, Niagara and Buffalo are already giving impressive illustrations. As time goes on the part to be taken in power production by waterfalls will become increasingly important. It is already vastly greater and more important economically than is generally supposed. There are known water powers in the United States able to furnish, if



fully utilized, something like 200,000,000 horsepower. Niagara, at the falls alone, can supply between 4,000,000 and 5,000,000, and a considerable additional quantity from the rapids above and below the falls, and numerous other water powers distributed over the hilly and mountainous portions of the country will in time no doubt become centers of power production and distribution. The one threatening aspect of the hydraulic power problem is the extreme probability that the continued destruction of forests and vegetation will make the streams more and more unreliable for continuous supply.

Wind power is another source of available energy, like water power, deriving its origin from the energy of the sun's rays, which may, as time goes on, provide a continually larger amount of utilizable energy for the use of mankind; but it is subject even in greater degree than water power to the objection that it is variable and unreliable for steady work. The winds are continually rising and falling. "As variable as the winds" well indicates the uncertainty of atmospheric currents as a source of power for industrial purposes. Rising to a gale and falling to a calm, alternately, the portion of the time during which this power is actually available is small, and, still worse, its available periods are as likely to come at unsuitable hours and seasons as when wanted. There is ample wind power for all purposes, undoubtedly, could it be regulated, stored, and economically availed of; but while no one can say what may or may not be accomplished by the coming inventor, mechanic, and engineer, it does not seem likely that this particular problem will be successfully solved even under the stimulus of vanishing fuel supplies.

Tidal power is still another possible source of industrial energy, and one which also has its own and peculiar difficulties of utilization. It is a regular and well-measured and well-known quantity; its hours of rise and fall, and the heights of rise and fall are well established. But when it is sought to design a system of utilization that shall be cheap, practicable, reliable, and compact—one that may compete with other power systems—it is found to be a very difficult and for the time at least impracticable system of power production.

At the moment, engineers and men of science are studying the art of reducing to harness the direct rays of the sun, and the solar engine is exciting special interest. It is no novelty, and many inventors have, for years past, worked upon this attractive problem; but probably at no time in the past has this matter assumed importance to so many thoughtful and intelligent men or excited so much general interest. John Ericsson, the great inventor and mechanic, when writing, in 1876, the great quarto volume which he intended should be the memorial of his life's work, devoted a very large proportion of its space to the account of his solar engines and of the scientific investigations made in the course of his work for the purpose of ascertaining the amount

of power thus derivable from the direct rays of the sun. His apparatus was simple—merely a conical mirror or reflector, receiving the heat of the sun on as large an area as was desired and was found practicable, and directing it to a focus where was placed a steam boiler or an air cylinder within which the fluid, heated to a high temperature, became available for use in a steam or an air engine. He reported the results of his experiments thus: \*

“It has already been stated that the result of repeated experiments with the concentration apparatus shows that it abstracts on an average, during nine hours a day, for all latitudes between the equator and  $45^{\circ}$ , fully 3.5 units of heat per minute for each square foot of area presented perpendicularly to the sun's rays. Theoretically this indicates the development of an energy equal to 8.2 horsepower for an area of 100 square feet. On grounds before explained, our calculations of the capabilities of sun power to actuate machinery will, however, be based on 1 horsepower developed for 100 square feet exposed to solar radiation. The isolated districts of the earth's surface suffering from an excess of solar heat being very numerous, our space only admits of a glance at the sun-burnt continents.

“There is a rainless region extending from the northwest coast of Africa to Mongolia, 9,000 miles in length and nearly 1,000 miles wide. Besides the north African deserts, this region includes the southern coast of the Mediterranean, east of the Gulf of Cades, Upper Egypt, the eastern and part of the western coast of the Red Sea, part of Syria, the eastern part of the countries watered by the Euphrates and Tigris, eastern Arabia, the greater part of Persia, the extreme western part of China, Thibet, and, lastly, Mongolia. In the Western Hemisphere, Lower California, the table-land of Mexico and Guatemala, and the west coast of South America, for a distance of more than 2,000 miles, suffer from continuous intense radiant heat.

“Computations of the solar energy wasted on the vast areas thus specified would present an inconceivably great amount of dynamic force. Let us, therefore, merely estimate the mechanical power that would result from utilizing the solar heat on a strip of land a single mile in width along the rainless western coast of America, the southern coast of the Mediterranean, before alluded to; both sides of the alluvial plain of the Nile in Upper Egypt, both sides of the Euphrates and Tigris for a distance of 400 miles above the Persian Gulf, and, finally, a strip, 1 mile wide, along the rainless portions of the shores of the Red Sea, before pointed out. The aggregate length of these strips of land, selected on account of being accessible by water communication, far exceeds 8,000 miles. Adopting the stated length and a width of 1 mile as a basis of computation, it will be seen that this very narrow belt covers 223,000,000,000 square feet. Dividing the latter amount by the area of 100 square feet necessary to produce 1 horsepower, we learn that 22,300,000 solar engines, each of 100 horsepower, could be kept in constant operation nine hours a day by utilizing only that heat which is now wasted on the assumed small fraction of land extending along some of the water fronts of the sun-burnt regions of the earth.

---

\* Contributions to the Centennial Exhibition, by John Ericsson, 1876. D. Van Nostrand, New York.

“Due consideration can not fail to convince us that the rapid exhaustion of the European coal fields will soon cause great changes with reference to international relations in favor of those countries which are in possession of continuous sun power. Upper Egypt, for instance, will, in the course of a few centuries, derive signal advantage and attain a high political position on account of her perpetual sunshine and the consequent command of unlimited motive force. The time will come when Europe must stop her mills for want of coal. Upper Egypt, then, with her never-ceasing sun power, will invite the European manufacturer to remove his machinery and erect his mills on the firm ground along the sides of the alluvial plain of the Nile, where an amount of motive power may be obtained many times greater than that now employed by all the manufactories of Europe.”

The probable value of the quantity of energy transmitted to the earth from the sun, according to the conclusion, after extended investigation of the late Prof. De Volson Wood, the greatest of American thermodynamists of the nineteenth century, is not far from that obtained by Langley—133 foot-pounds per square foot of receiving area per second, about  $133 \cdot 550 = 0.24$  horsepower, or the equivalent of  $\frac{1}{4}$  square feet per horsepower.\* As actually utilized, Ericsson reported his solar engine to supply a horsepower from 100 square feet of receiving area, on a bright, clear day, and other experimentalists, with apparently less efficient apparatus, report a horsepower from about 150 square feet in sunshine.

This figure is confirmed by recent experiments at Pasadena, Cal., where it is said that the efficiency reached by Ericsson has in some cases been attained. The California apparatus includes a truncated conical mirror, 33 feet 6 inches in diameter at the top and 15 feet at the bottom, which concentrates the rays of the sun received upon its 1,788 facets at a focus where a boiler is placed, and where steam is made, to operate a steam engine of small power. The whole mass of glass and iron composing the mirror is moved by a suitably arranged clock, and is automatically held with its axis directed toward the sun. The boiler is carried on the same frame and moves with the mirror. It is 13 feet 6 inches in length, and contains about 10 cubic feet of water and 8 cubic feet of steam space. The steam pressure is carried at 150 pounds per square inch. It is rated at 10 horsepower. This power is utilized in pumping water, but the reported figures are inconsistent with its rating. To set the machine in operation it is only necessary to turn the apparatus by hand until its axis points at the sun's disk and to set the clockwork in operation. To stop it requires simply the turning of the mirror away from the sun and the stopping of the machinery which adjusts it.

---

\* Wood employs this value in his classic and remarkable paper “On the Luminiferous Ether,” the first rational determination of the physical properties of the ether, and a most important and impressive work. Phil. Trans. Magazine, November, 1885. App. to Wood's Thermodynamics; N. Y., 1887. J. Wiley & Sons.

The uncertainty which the engineer feels regarding this type of motor is due largely to the difficulties arising from the fact that the sun is not always available, even by day, and that it is entirely out of reach for power purposes for one-half the twenty-four hours, and he has as yet no idea of practical methods of storage, either of the heat or the power, for use during cloudy periods, hours, days, and weeks even, when the engine can not be kept in steady operation. It is, of course, possible that much improvement may be effected in the electric storage battery, and it is even true that great improvements in that precious device are apparently already in sight; but even the ideal and perfect battery, could it be realized, would probably prove so costly and so enormous, as a part of this system of sun-power utilization, as to make its use practically out of the question in temperate regions where the sky is overcast so often that not over one-half the direct heat of the sun is each day, on the average, available, or in the Tropics, where the rainy season makes it unavailable for months together. Where, as may occasionally be practicable, storage may be effected by raising water into extensive and elevated reservoirs provided by nature, this difficulty may prove less serious; but such exceptional advantages of location can not be relied upon for any important aid in securing general utilization of the solar motor.

For necessarily continuous use of power it is thus evident this system gives little promise, and a cotton mill, for example, that must go into operation only when the sun comes out from behind a cloud and go out of action the instant it disappears again can hardly be expected to pay dividends. Water power must be its reliance when coal can not be employed, rather than either sun power or wind power, and its work must be done where a sufficient amount of fall and flow can be had to meet its maximum requirements, even at the period of minimum flow.

The availability of sunlight and heat for the purposes of the engineer differs greatly in different places, and with every change of latitude, as well as from season to season. This variability is an enormous handicap where it is sought to employ this energy. The remark is attributed to Professor Langley that all the coal deposits of Pennsylvania, if burned in a single second, would not liberate a thousandth part as much heat as does the surface of the sun in that unit of time. Yet it is evident that our coal deposits, so long as they last, are worth more to us than all the available heat of the sun.

In conclusion, we may thus make the following deductions:

The rapid and rapidly increasing destruction of our stores of mineral fuel must, sooner or later, bring us to a point at which it will be no longer possible to derive the power required in the arts from that source.

That period is likely to be ushered in before many generations, and

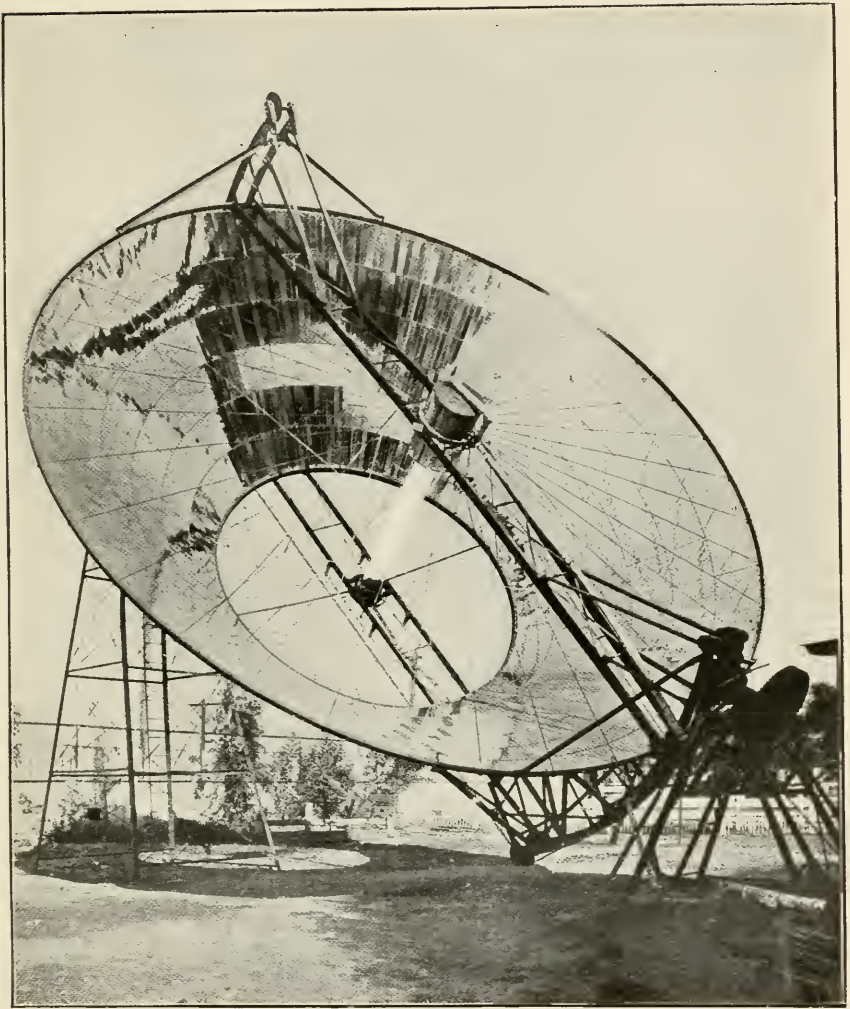

SUN REFLECTOR.

Blowing off steam with a pressure of 210 pounds. From article "Harnessing the Sun," *Worlds Work*, April, 1901. By courtesy of Doubleday, Page & Co.



is, in fact, in some portions of the world already presenting its preliminary symptoms—difficulty in mining and increased price of the fuel in the market, as well as the expressed anxiety of statesmen guarding the interests of the great manufacturing districts of Europe.

The ultimate outcome must be the gradual extinction of our fuel supplies, and if no substitute can be devised by the ingenuity of man, the compulsory retreat of the civilized races into the tropics, and, even there, the interruption of the manufacturing industries on the scale necessary to the maintenance of civilized life as we know it to-day.

While it may be true, as has recently been estimated, that the belt extending thirty degrees on either side of the equator may be capable of sustaining a population of ten thousand millions, over ten times the number now inhabiting that portion of the globe, such a population will require correspondingly increased power supplies, if it is to be a civilized population as we to-day define the word.

The available sources of power remaining are wind and water power, and the utilization of the energy of the direct rays of the sun. The last, though apparently most universally available, has hitherto been unused, while the indirect systems of employment of the sun's energy have been very extensively employed, the deduction being that the former process presents elements of peculiar difficulty.

Water power is, to date, the most available, and the common substitute for the heat engine. When the existing waterfalls are generally utilized, they will go far toward meeting the needs of the race in power production, and the coincident use of the electric current for the distribution of energy from its source is now making this element of the problem far more promising of solution than previously. Yet it is doubtful whether water power will suffice for all the requirements of later generations, even though the usual result of stimulated brain work, checking of the growth of population, should hold down the numbers of the human race to something like those of the present time.

Wind power, although even more generally distributed than water power, is subject to its own peculiar disadvantages for our purposes, and, while likely to come more and more into use for purposes like that of raising water to higher levels, and where steadiness and continuity of action are not important, will probably be found in great part unavailable for large powers or for the great majority of uses which commonly demand steadiness of power and action.

Solar motors make available an immense quantity of active energy by direct utilization. They are evidently practicable in the sense that there is no inherent mechanical difficulty in their construction and operation. They are subject, however, to the same defects of lack of steadiness of source of energy, of need for provision for extensive and prolonged storage, if to be generally employed, and to the serious

objection of large cost per unit of power delivered. Whether this cost will be so great as to balance the gain coming of free delivery to the machine of the energy to be transformed can be known only when we are driven to the serious task of providing substitutes for the heat engines.

Ericsson made a working steam engine deriving its energy from the direct rays of the sun, and proved that either steam or air could be employed in such an engine as the working fluid. He also showed what is the amount of power practically derivable from the sun's rays through this method of utilization of the heat of the sun.

Later testimony, so far as it goes, confirms his statements, and the mechanical possibility is beyond question that, in future centuries, when our fuels are gone, we may largely utilize the sun's energy in this manner. But it may yet be found that this threatened exhaustion of our fuel supplies is not the only, or perhaps even the first, limit likely to be set to the progress of the world of humanity on our globe. The exhaustion of our iron ores, like our platinum deposits, the mingling with the air of the products of combustion of our fuels while they still last, the pollution of our water supplies, and many other possible obstacles to progress and growth, will have their effects, individual and combined, and our most serious problems are quite likely to be found at an earlier date than that of the loss of our fuels; the last-named danger is, in fact, already upon us. This generation need not attempt to cross the first of the bridges on the list, although a very seductive problem is presented to the engineer. This problem may be enunciated thus:

To find a system of gathering and storing the energy of the direct rays of the sun, for utilization in power production, by a special form of heat motor; to find, next, a method of transforming the energy thus collected into mechanical power; and to discover a method of storing, for later use, excess power obtained during periods of sunshine, tiding over the sunless periods.

The problem will be solved only when the system thus perfected is so designed and constructed as to be able to provide power for industrial purposes so cheaply that a business profit can be made through its use.



# THE NEW RADIATIONS—CATHODE RAYS AND RÖNTGEN RAYS.<sup>a</sup>

---

By A. DASTRE.

---

It is generally agreed that one of the characteristic features of our age is the enormous development of the applications of science. This is a commonplace truth. We are completely surrounded on all sides by these applications; they are intimately mingled with all the conditions of everyday life; they take part in our housing, our clothing, our lighting, our transportation in many ways; they assist us in communicating with our friends, far and near; they produce our portraits, or they simply amuse us, so that they can not be ignored. But this utilitarian aspect of modern science should not obscure its educational and philosophic value. Referring, for instance, to contemporary physics only, the march of ideas has not been less remarkable than the progress of discovery. Theory and practice have advanced side by side. Boldness of speculation has attained the same height as skill in experimentation. It may be said in this connection that the evolution of theories compares favorably with the marvelous development of facts, and the philosophy of science with science itself. This we have previously attempted to show to our readers in our essays on osmose, on cryoscopy, and on tonometry; here we wish to examine from the same point of view ideas that have accumulated in recent years concerning cathode rays, Röntgen rays, and on the radio-activity of matter.

## I.

The term "cathode rays" was suggested in 1883 by the well-known physicist, Wiedemann, who had been engaged in studying them, but the object to which the name was applied was not entirely new. Cathode rays had several years before occasioned celebrated experiments in the hands of an English scientist, W. Crookes, long well known through other original investigations. The beautiful experiments of Crookes, disseminated by their author throughout Europe, had attracted the attention not merely of the majority of physicists,

---

<sup>a</sup> Translated from the *Revue des Deux Mondes*, Dec. 1, 1901.

but of the public itself. Presented to the members of the British Association at their meeting at Sheffield in 1879, repeated in 1880 at one of the soirees of the French Association, held in the Observatory of Paris, these new and brilliant phenomena aroused immense enthusiasm. Crookes attributed them to a special condition of matter which he called "radiant matter." Cathode rays are simply radiant matter electrified. The English scientist laid great stress on this fourth state of matter; he believed, and others believed with him, that he had opened a new path to science.

This hope was vain, or at least deferred for a long time; it was necessary to wait fifteen years until the discovery of X-rays (connected with cathode rays, as will appear presently) attracted the attention of scientific men. However, investigators had not abandoned this new track; they had followed it with perseverance in the silence of their laboratories. Among these zealous workers must be named in the first rank the German physicist, Hittorf, to whom must be given the honor of having discovered cathode rays. He had pointed out their existence ten years before W. Crookes. In justice to him cathode rays might be called Hittorf rays, for the same reason and on the same ground that the X-rays are called Röntgen rays, and the radio-active rays Becquerel rays.

Besides Hittorf should be named Hertz, Wiedemann, and Ebert, Schmidt, Lenard, and J. J. Thomson, whose researches were gradually developed until 1895. At this period suddenly appeared the discovery by Röntgen, and investigations received a new impulse. Soon after appeared in different countries the publications of Birckeland, of Majorana, of W. Wien, and in France those of J. Perrin, of Villard, of Deslandres, and of H. Poincaré.

These numerous researches had a double object. It was proposed on one hand to complete the experimental study of the phenomena, and on the other hand to furnish an explanation of them. The task in both cases is very attractive, but the interest of the theoretical question is incomparably greater. On this new field of cathode phenomena was renewed the discussion which for more than a century had agitated the physicists concerning the interpretation of luminous phenomena. Cathode rays are not luminous rays, but their explanation was equally opposed to the theory of emission and to the theory of undulation, to ponderable matter and to ether. The discussion of the commencement of the century with reference to light was renewed in its last decade with reference to electricity. Sensational and theatrical effects succeeded each other. With Crookes in 1880 the emission theory triumphed; the cathode ray certainly appeared to be a material projection, a ballistic trajectory. With Lenard in 1894 (who had caused the cathode rays to penetrate a vacuum without diminishing the latter) the theory of an immaterial foundation, rays of ether, was

uppermost. J. J. Thomson in 1897 returned to the emission of particles, but these projectiles were no longer molecules, atoms or ions—the smallest division of matter recognized, but the fragments of atoms, *atomic corpuscles*. Finally, M. Villard in 1899 determined the nature of these bodies, and showed that they were formed of hydrogen, in short corpuscles or fragments of atomic hydrogen. It was shown that the cathode rays exhibit the spectrum of hydrogen, and if every trace of this gas is successfully removed the cathode emission is suddenly suppressed.

## II.

After this presentation of the theoretical interest of these new rays it will be well to give a short description of them. Their appearance is dependent upon conditions of the electric discharge in rarefied gases. Phenomena of this character are frequently seen, as for example, the illumination of Geissler tubes, or of the electric bulb. As these experiments are among the most brilliant and most attractive that can be performed with electricity they are shown on every occasion, as much for the beauty of the spectacle as for the instruction of the spectator.

Let us imagine, then, an electric bulb, an oval vessel of glass in which are placed two metallic poles, two bulbs or, in short, two electrodes of some shape or other, separated by smaller or greater intervals, and charged with electricity. Their electrification will be maintained, for example, by placing them in connection with the induction poles of a Ruhmkorff coil. An electrostatic machine can also be used, if furnished with a condenser whose collector is connected with one of the electrodes. A short tube provided with a stop-cock allows the ovoid bulb to be exhausted of air. When the electric tension passes a certain limit a current is established. A flash of flame passes from the positive electrode (the anode) to the negative electrode (the cathode). Under these conditions, having a rarefied gas and suitable charge of electricity, this luminous trajectory, instead of being blinding white, sharp, rectilinear or zig zag as the ordinary spark is constituted, appears as a diffuse glow, varied in color according to the nature of the gas.

If the bulb or flask which contains the electrodes permits changing the place of the positive pole and approaching it to different points of the surface of the glass, the luminous trail is seen always to leave the wandering point of attachment in order to pass to the fixed negative pole. The passage will be more or less direct or rectilinear, it will approach more or less the axis of the bulb, and will vary in consequence with the shape of the same. And by displacing the positive pole, the current, this trajectory of discharge, can be directed at will. In ordinary cases this is what usually occurs, especially when the rare-

faction is of a moderate degree, when the vacuum is maintained at a few hundredths, or at most a few thousandths of an atmosphere. One must not be contented with this degree of exhaustion if it is desired to study the cathode rays. It is necessary to go further, as did Lenard and Crookes, without, however, going too far. The English physicist, in particular, pushed the exhaustion to a prodigious degree. In the Crookes tubes, so called, the pressure is only one millionth of an atmosphere. The pressure of the remaining gas valued in millimeters of mercury does not reach more than 0.00076. The English scientist claimed that when exhausted to this point the residue no longer has the properties of ordinary gases; according to him it is a *hypergas* as different from the true gaseous state as the latter is from the liquid state, and forming a fourth condition of matter, following the liquid, the solid, and the gas proper; this he called radiant matter. Crookes, relying on what the kinetic theory teaches with reference to the constitution of gases, desired to determine the nature of this fourth state of matter. In reality, the gas, rarefied to the millionth of an atmosphere, has not acquired, by this fact alone, an entirely new character; but it has acquired it most certainly when electrification is added to the rarefaction, and it is then that it constitutes the emanation or the cathode ray.

We have said that the vacuum must not be pushed too far, if one goes beyond the millionth of an atmosphere—and the perfection of mechanism allows going much further than that—the gaseous residue can not be electrified; electricity will not pass through; there is no longer a current. The electric force is incapable of penetrating absolute vacuum; this resistance of the vacuum to the passage of electricity is an article of faith among physicists, especially since the experiments of Walsh, of Morren, and of Schultz. The importance of this principle is very great from the theoretical point of view; it furnishes, in fact, a new test for matter. But in its application its practical value is very restricted. The experiments of Lenard, after those of Hertz in showing us the propagation of certain forms of electricity in vacuo, instruct as to the nature of these restrictions. We shall say, with J. Perrin, that it is very probable that recognizable electricity which can be experimentally detected can not propagate itself without a material support, but this is not certain.

If now we return to Crookes's tube, in which the vacuum has been pushed to one millionth, we shall see that the current behaves itself rather differently from what it does in the tubes where the rarefaction is less. The path of the current has lost much of its brilliancy; it no longer appears as an uncertain glow, wavering, striated, of a hue intermediate between rose and violet. All the remainder of the interior of the bulb remains dark. The electricity passes again and follows

the same path as before between the positive electrode and the cathode. The principal flow has been joined by a secondary one, from all points of the tube the positive currents are directed toward the cathode, and go to reenforce the principal current. These positive charges which descend from all points of the periphery form the counterpart of the negative charges, which can be seen fixed on the cathode rays. Their existence, their development, their circulation, result in consequence from the existence, the development, and the inverse circulation of the negative electricity that carries with it the cathode ray.

Such is the cathode afflux; it is composed of the current directed toward the positive electrode and of secondary currents directed from all parts of the recipient toward the cathode. M. Villard has made it very plain that all these obscure or dim emanations are united in the axis of the bulb to the principal flow.

This cathode afflux has besides the character and the properties that physicists and chemists attribute to the electric current. It touches directly the cathode. If it happens that this negative electrode—which we may suppose to consist of a small, circular, metallic disk—is perforated with a hole, a portion of the cathode afflux crosses this opening and pursues its journey beyond, after being discharged in passing. This neutral electrical current, these discharged rays, form the Canalstrahlen studied by Goldstein.

All these details with relation to the currents which flow toward the cathode indicate the care with which physicists have studied the subject, so that none of the phenomena which take place in Crookes's tube may escape them. It might be said, however, that they are foreign to our principal subject, which is the cathode emission. The afflux which we have just seen reach the cathode is in fact perfectly distinct in every respect from the cathode radiation which follows it and which alone interests us. The latter is formed of a pencil of rays perpendicular to the surface of the cathode. It is in the present case a cylindrical pencil having for a base the circular disk; it traverses the tube in a perfectly straight line without being disturbed by the rays flowing toward the cathode in an opposite direction, of which we have just been speaking; it passes by them and through them unchecked.

This new pencil implanted normally on the cathode is not luminous. It is not directly visible; it forms a dark spot in the Crookes tube. It would entirely escape observation if it did not excite a peculiar fluorescence opposite to the cathode at the points where it meets the sides of the tube. The material of the glass becomes illuminated at these points and presents a luminous brilliant spot of a green color. Crookes had the idea to arrange in the interior of the tube, in the path of this pencil between the cathode and the wall, a variety of opaque bodies, as, for example, a cross of aluminum. He then saw outlined

upon the clear fluorescent background the exact silhouette of the cross. In this way perfect geometric shadows of the objects introduced can be obtained in every case.

This experiment necessitates the conclusion that the cathode emission is rectilinear. The cathode, the screen, and the silhouette are all on a straight line. Things occur, in short, as if a single ray left each point of the cathode, exciting luminosity at the very spot where it encounters the walls. Without prejudging in any way the nature of the phenomenon, it is proper to use the expression cathode rays.

A close study of the shadows formed by divers screens, of the silhouettes outlined by these rays, leads to a new and instructive point; it shows that they are implanted at right angles to the surface of the electrode; they are perpendicular to it at every point. It must be added, however, following Goldstein, that it is not a strict rule; if accepted, it results that the shape of the pencil varies in a simple manner with that of the cathode. The latter is sometimes arranged as a slightly convex disk; thereupon the rays form the trunk of a cone which strikes the walls of the tube like a circular skullep. If the cathode disk is a mirror with spherical concave surface the perpendicular lines at the surface form a conic pencil and converge toward the center of the image of the sphere, where they form a focus. The effects peculiar to cathode rays are magnified by this concentration, in the same manner that the effects of luminous rays are increased in the focus of a lens. In this manner Crookes was able to show the heating action of his supposed radiant matter; that is to say, of cathode rays. He succeeded in fusing, at one of these foci, not only glass, but a wire of iridium-platinum, an operation which requires a temperature of more than  $2,000^{\circ}$ .

It is not only at the end of its path at the point where it strikes the walls of the glass tube that the cathode pencil can be rendered visible. Hittorf and Goldstein, in 1876, furnished the means of rendering it visible at all points of its path by discovering the phosphorogenic power of the new rays. The illumination which these dark rays excite in the glass of the bulb they also produce on other bodies placed in the interior. Rock crystal appears of a blue color, precious stones of divers colors, rubies project a beautiful red glow, diamonds take on an extraordinary brilliancy. The earthy sulphides which are naturally phosphorescent—that is to say, able to store up the luminous rays and yield them up afterwards—are lighted up most vividly. Wurtzite (crystallized sulphide of zinc) becomes dazzling. By arranging a fragment of one of these substances in the path of the pencil, the latter becomes visible throughout. It becomes possible in this way to study the properties of cathode rays.

The results of this study should be briefly mentioned. In the first place the two laws already announced are verified—that the cathode ray

is rectilinear and that it is quite sensitive perpendicular to the surface of the electrode. Again, the mechanical effects produced by these rays are of great interest, owing to the support which they seem to give to the theory of the emission of matter. They are shown by a beautiful experiment. Two rails formed of glass rods and placed in the path of the cathode rays support the axle of a paddle wheel. This little machine begins to move, revolves continuously as soon as electrical communication has been established, as if the flanges received blows—a bombardment, according to the expression used by Crookes—of material particles issuing from the negative electrode. On reversing the direction of the current the wheel revolves in the opposite direction. The ballistic explanation seems so reasonable that it naturally insinuates itself into the mind and gives rise to a belief in cathode projectiles. However, on reflection, the argument is by no means conclusive. Everyone has seen in the show windows of opticians the little instrument which is called a radiometer, which was itself an invention of Crookes. It forms a kind of windmill, exceedingly light, and inclosed in a bulb of glass that has been exhausted of air. It begins to move in the same way as the water wheel of the preceding experiment, but under the action of luminous rays—that is to say, of vibrations of the ether, without suggesting this time a bombardment of projectiles.

A second property of cathode rays, an unexpected and very remarkable one, is that they are attracted by a magnet. Making the pencil visible by means of a phosphorescent screen placed within the tube it is seen to bend away on approaching a magnet; it can be attracted and repelled at will by varying the position of the magnetic agent. The amount of the deflection depends partly on the strength of the magnet and partly on the velocity of the cathode rays, a velocity which can be determined by varying the pressure of the gaseous residue that fills the bulb. On giving proper motion to the magnet it is easy to conceive that one might succeed in twisting the pencil into a spiral. This obedience to the directive force of the magnet goes so far as to allow it to form a circle upon itself. In this experiment the cathode ray behaves like an electric current of which the negative pole would be the cathode and which runs along a metallic wire. This magnetic deflection is easily explained by the emission theory; the rays would be formed by a row of electrified material particles following each other rapidly and carrying an electric charge. This transportation of electricity by the transportation of matter is called a current by convection. Rowland, Röntgen, and other physicists have shown that currents of this nature are similar to ordinary currents by conduction. On the other hand, deflections produced by a magnet are unknown in ethereal, calorific, luminous, and actinic radiations.

In the third place the cathode ray is electrified. This we assumed a

little ways back in saying that it was similar to a row of electrified particles, that is to say, to a current. It is necessary, therefore, that the charge which it transports should be made manifest. Crookes believed that he had succeeded in doing this. Ebert and Wiedemann showed the fallacy of his demonstration, but it was a young French physicist, M. Jean Perrin, who, by a very neat experiment, made plain the essential character of cathode rays, which is that they must be charged with negative electricity.

The cathode phenomena, such as we have described them, fills the whole of the interior of the bulb; within it, it begins and ends. Up to 1894 it had been impossible to study these rays under the experimental conditions in which they occur. The rays remain shut up in their birthplace as in a prison. Lenard succeeded in liberating them, and his beautiful experiments of 1894, which drew these captive rays from their prison of glass, created a great enthusiasm among physicists.

The cathode rays are stopped by glass; this is well known. Most other substances act the same way. However, Hertz in 1883 had announced that metallic plates would permit the passage of these rays provided they were sufficiently thin; their thickness should not be greater than a few thousandths of a millimeter (*micron*). Lenard suggested replacing the fluorescent portion of the glass tube on which the cathode pencil strikes by a piece of metal, and it was necessary that this plate should be stout enough not to yield to the pressure of the air. Herein lay the difficulty, which Lenard succeeded in overcoming. He arranged in his Crookes tube a small window, in which he inserted a plate of aluminium three-thousandths of a millimeter in thickness. This leaf proved to be capable of resisting atmospheric pressure and of sustaining the vacuum within. The cathode rays, more subtle than gaseous molecules, passed through, permitting them to be studied without.

They behaved without exactly as within the tube; they proved to be rectilinear, deflected by a magnet and capable of producing fluorescence; also equally capable of making an impression on a photographic plate. Most extraordinarily they had preserved their negative electrification in spite of the thickness of the metal which they had traversed. This fact was unexpected and unexampled. It indicates that the negative electrical charge is an essential and indelible character of the cathode ray, and that it can not lose it without ceasing to exist.

These experiments taught at the same time that the cathode rays possess a very limited power of penetration, even through gases. Unless these gases are extremely rarefied the rays are quickly stopped and scattered by molecular obstacles. On the contrary, when the vacuum is pushed very far they remain unchanged; it has been possible to follow them the length of a meter and a half without noticing any diminution of power.



In conclusion, two other characteristics of the cathode rays must be noticed. The first consists in the power that they transmit to gases through which they pass, of conducting electricity. Gases in a dry state, as is well known, are nonconductors; an electrified body, for instance, a gold-leaf electroscope or a condenser, holds its charge. If it sometimes appears otherwise it is because the gas is not dry, and the diminution should then be attributed to the vapor of water. But if a cathode ray just comes in contact with air which is really dry, near this apparatus, the latter is seen to discharge itself at once. The gas has acquired a certain degree of conductivity. This same property belongs, as we shall soon explain, to Röntgen rays and to Becquerel rays. This characteristic is common to all these radiations, and is probably the one which can be easiest investigated, and even measured. By means of an electroscope inclosed in a box full of dry air these divers radiations are studied. By this process Mme. and M. Curie discovered the new radio-active bodies, polonium and radium, and M. Debierne by the same means discovered actinium.

The last peculiarity is also common to these three kinds of radiation, as well as to every species of electric current. It consists in this, that both effect condensation of the vapor of water when the latter is near its point of saturation, producing a kind of mist. This mist, which forms instantly on the passage of the current, or of the rays, becomes a visible and palpable sign of their presence. It is a beautiful lecture experiment and one easily reproduced for public exhibition, and has often been repeated within the last two or three years. The invisible vapor escapes from a narrow tube connected with a flask full of boiling water; on approaching to it a metallic point strongly electrified and from which the fluid escapes in the form of an aigrette that can easily be distinguished in the dark. As soon as contact has been made the jet of steam assumes the aspect of a dense mist or of a thick smoke.

Allusion may be made to the possible applications of this phenomenon to meteorology without insisting upon them. There is another curious application which was made by J. J. Thomson in measuring the number of cathode projectiles which exist in a given space at a given moment. By combining this calculation with electro-metric investigations it has been possible by skillful comparison to determine the negative charge borne by each cathode projectile, and, finally, its mass. The latter is extremely small.

The cathode rays of a single pencil are not all identical. The velocity of propagation is not equal, and that is the reason why a magnet deflects them unequally, just as a prism bends unevenly the rays which form a beam of solar light. There is magnetic dispersion and a magnetic spectrum for the rays emanating from the cathode, exactly like the luminous dispersion and luminous spectrum formed with the sun's

rays. This fact was determined about the same time by Birkeland and Jean Perrin.

By exceedingly clever experiments it has been possible to measure the velocity of propagation of the cathode rays, which is, according to the emission theory, the true velocity of the projectile thrown off by the electrode. This velocity is enormous and, moreover, varies greatly according to the circumstances of its production. It may be 200 kms. a second, which is the lowest limit, and may reach 50,000 kms., which seems to be the highest limit, or one-sixth the velocity of light.

We can scarcely point out the principles by which this calculation has been made. It is founded upon the experimental measurement of the magnetic deflection exerted by a known magnet and by the electric deflection excited by an electric current having an intensity equally known. It is very clear that these deflections depend upon the velocity and the mass of the cathode projectiles. In short, it is evident that the magnet or the current will deflect the cathode ray more if it travels with a feeble velocity and less if the velocity is great.

It is possible, moreover, to diminish this velocity in order to give greater accuracy to the methods. Lenard made use for this purpose not only of the rays produced in the Crookes tube but also of those the existence of which had been discovered by Gustave Le Bon and which result from the action of light on metals.

The velocity of the cathode ray is prodigious and can produce mechanical effects surpassing the imagination, if you consider that the mass of the projectile is infinitely small and the projectile itself but the fragment of an atom. Jean Perrin has calculated one of the effects, the calorific effect which will be produced by the blows of an appreciable proportion of these projectiles. The quantity of heat which a kilogram of this matter would generate, when suddenly arrested by an obstacle in its course, would be sufficient to raise instantly to the boiling point the water of a lake 1,000 hectares in extent and 5 meters in depth.

The measurement of the cathode velocity brings to bear a final argument in favor of the ballistic or materialistic theory. If the cathode were the result of certain vibrations of the ether, instead of resulting from the projection of matter, it would not be possible to comprehend that such a disturbance should be propagated with a variable velocity of 200 kms., since the same medium transmits the solar disturbance with a uniform velocity of 300,000 kms.

No matter from what side we study this question the advantage always remains with the theory of material emission. In this discussion which has been renewed in our time between the two systems of emission and of undulations, this time it is the first that carries off the palm.

The cathode ray may be considered, then, as formed of a row of

projectiles negatively electrified. Why should they move in a straight line perpendicularly to the surface of the cathode? Because they are repulsed and driven violently by the electric charge of the cathode.

The electro-metric and electro-magnetic measurements, combined with those of which we have formerly spoken, and which allow the calculation of the number of cathode projectiles in a given space by means of the condensation of a mist have led to surprising results whose accuracy is amazing. By these means the cathode projectile has been found to have a constant mass, equal to the thousandth part of one atom of hydrogen.

The projectile, then, does not depend upon the cathode, as Crookes had already determined. It is composed of hydrogen, as proved by M. Villard without question. It has its origin necessarily in the breaking up of the atom of hydrogen. This, instead of being the final expression of simplicity and of lightness, as chemists believe, appears to be a quite complex edifice and rather heavy, since the current of the Crookes tube removes from the stones which represent it but the thousandth part of its mass. These stones are the fragments of atoms, or the atomic corpuscles of J. J. Thomson. The atom is no longer indivisible. Here we shall stop, not pushing the analysis further, although the state of science would permit it; but we should enter upon the subject of the constitution of matter, a subject which can only be incidentally referred to here.

### III.

Cathode rays have no practical application. They are produced under extremely peculiar conditions, in a barometric vacuum, in the interior of a bulb from which it is almost impossible to liberate them. We should have no excuse for having entertained our readers so long had this study offered only the interest of pure curiosity and an opportunity of proclaiming the cleverness of our physicists. But it has another bearing. In narrating the history of these rays we have included that of rays of the same family—Röntgen rays, of which the applications are so numerous, and Becquerel rays, which are but a mixture of the two other kinds. In the second place, the cathode rays are the progenitors and the necessary generators of the others. The mechanism and the true nature of the latter are better known.

Moreover, cathode rays (and Röntgen rays as well as those of Becquerel, which accompany them or emanate from them) are not merely the simple results of design on the part of physicists; they constitute a natural phenomenon which can not be neglected. Far from being of rare occurrence they are incessantly produced. Not a single ray from the sun falls upon a metallic surface, not a flame is ignited, not an electric spark flashes, not a current of electricity is produced, not a substance becomes incandescent without the appearance of a

cathode ray either in a simple or transformed condition. G. Le Bon deserves the credit of having first perceived the universality of this order of phenomena. Although he, indeed, made use of the inappropriate term "black light," nevertheless he recognized the general character and the principal properties of this creation. Above all, he assigned to the phenomenon its true place, transferring it from the workroom of the physicist to the grand laboratory of nature. P. de Heen, the well-known professor of the University of Liège, adopted a similar conception. He considers that nearly all the centers of disturbance of the ether generate emanations similar to those which take place in a Crookes tube. We shall have occasion to return to this in connection with the radio-activity of matter.

#### IV.

The enthusiasm and admiration which the discovery by Röntgen aroused at the close of the year 1895 is well remembered. The learned physicist of Würzburg exhibited photographic silhouettes obtained through opaque bodies, sheets of pasteboard, leaves of paper, thick books, dictionaries, and wooden boards several inches in thickness. He furnished the means of receiving on a screen the fluorescent shadows of bodies concealed by wrappings, or inclosed in boxes, that is to say, made it possible to see indirectly through these obstacles.

Very soon useful applications added to the interest of mere curiosity which was manifested at the start. Radiography was applied to the detection of the sophistication of certain products, to determining the contents of a box without opening it, and to similar uses. But by far the most important of these applications was that made to medicine and surgery. Everyone has seen these radiographs publicly exhibited. They portray the malformations, the injuries of the skeleton, the alterations of bones, the presence in the tissues of foreign bodies, such as shot, needles, fragments of metal and the like, and in certain cases they disclose the existence of lesions in the viscera of divers kinds. When perfected, they will realize the dream and the aim of normal and pathologic anatomy, which is to show the body sound or diseased as if it was transparent throughout. It is useless to dwell further on these particulars; their history is developed right under our eyes and the daily press details its progress from day to day.

Röntgen rays derive their origin from cathode rays. Crookes's tube, the generator of cathode rays, was the means employed by the German physicist, and by all investigators who have followed him. But in this apparatus the only part useful for producing the effects which we have seen is the fluorescent spot situated opposite to the cathode from which it receives the emission.

From that point the new rays are projected in all directions and not merely in the original line. All substances which arrest the cathode

rays become the starting point of Röntgen rays. It makes little difference whether a body is placed within the tube or whether it forms the wall of the tube, nor is it of any importance whether it becomes fluorescent or not under the cathode action: from the moment that it receives and arrests the first ray it generates the second. It has been found advantageous to arrange a slight modification of the apparatus in order to increase its power. An electrode is used having the form of a spherical mirror which concentrates the cathode rays at a single focus. Near it is arranged a platinum foil or some other infusible substance which intercepts the cathode emission and arresting it transforms it into Röntgen rays, which pass through the thinnest point of the tube and may be collected without. This apparatus is called a focussing tube.

The Röntgen ray is plainly to be distinguished from the cathode ray, which has given it birth by several characters, of which the two most essential, from a theoretical point of view, are that it is not attracted by the magnet, and that it is not electrified. The cathode ray, on the contrary, carries an electric current and can be deflected by a magnet. On these two characteristics has been founded the theory of its materiality, as we have already said. They are wanting in the Röntgen ray, therefore we can not be sure that it results from the emission of matter. On the contrary, circumstances are in favor of its immaterial, ethereal, vibratory nature.

To these two distinctive, essential, traits must be added the two following, which are no less important: The cathode ray has not the power of penetration. It is immediately absorbed or diffused; whereas the Röntgen ray is very penetrating and nondiffusible.

We have just seen that the Röntgen rays originate at the point where the cathode rays encounter solid substances. The violence of the blow of the cathode projectile against the material molecule disturbs it and increases its calorific energy: at the same time it makes the surrounding ether oscillate and produces the fluorescence of Crookes's tube. The operation which produces the X-ray yields then, at the same time and accessorially, luminous rays (visible fluorescence), and at other times chemical rays, ultraviolet rays (invisible fluorescence), and probably still other unknown radiations.

Setting aside these accessory radiations—that moreover may be absent—in order to consider the principal one, we have said that the latter is disclosed by its chemical action on the salts of silver (photographic impression) and by its power of exciting the luminosity of phosphorescent screens. If an opaque body is placed in a straight line between the source of the ray in the screen its shadow appears thereon with an astonishing distinctness. The formation of these geometric shadows proves a perfectly rectilinear propagation and justifies the name of "ray" here employed.

At the outset the most surprising characteristic of these rays is their power of penetration. They pass as easily through a volume of a thousand pages as a ray of light passes through a window pane. Both cases exhibit the same prowess of nature; and if the latter fact no longer astonishes us, it is because, as Montaigne says, "familiarity with things removes from them their strangeness." Our surprise arises in observing the newcomer accomplish that which was impossible for our old friend, light. We were formerly no less surprised to learn that the ultraviolet rays of the solar spectrum passed through a piece of silver foil, which, we may say, parenthetically, made possible for the first time photography of the invisible. That which is permitted to one ray is prohibited to another. Röntgen's ray, which traverses an oak plank 2 inches in thickness and a plate of aluminum more than a centimeter thick, is stopped by several meters of atmospheric air, the passage of which is but a trifle for the ray of light.

There is another difference between the Röntgen ray and the luminous ray—their conduct in the interior of bodies. Both these rays are absorbed while on their journey; their nature is changed; they are annihilated; their energy is transformed into some other force—heat for instance. This end is common to them. But light has another property which is peculiar to it. In certain bodies having a granular structure, such as roughened glass and the powder of rock crystal, the light is diffused; the path of the rays is broken by reflections and by numerous refractions. Each particle, then, behaves as a source of light, emitting rays in all directions, and the body is illuminated. It would be useless to increase the intensity of the beam of light with the expectation of seeing it transmitted; the illumination would only be increased.

The Röntgen rays behave very differently. They are only lost through absorption. By increasing the intensity of the rays they will be seen to gain more and more in the power of penetration. They are not diffused. They pursue their path rigidly inflexible, undoubtedly weakened, but never deflected by any obstacle. A ray of light should not be taken as the type and symbol of ideal rectitude, but rather the ray of Röntgen.

There are several varieties of Röntgen rays, as there are of cathode rays. They form an entire scale, and may be distinguished from each other by their degree of penetration. Some are ultrapenetrating. Others are extinguished at a distance of a few millimeters from their origin. This depends upon the generating apparatus, on the current employed, and on other circumstances controlling their production.

When a Röntgen ray happens to strike a solid body, particularly a metal, it gives rise to rays of the same nature, but having less penetrating power. They are also much more active from electric and photograph points of view. These secondary rays have been studied

by M. Sagnac. In the same conditions the secondary rays originate tertiary, and so on, in such a way that there exists at the surface of metals struck by Röntgen rays a whole system of radiations, which form a complicated envelope, conducting electricity and photogenically active.

It is easy to see that the fact that Röntgen rays are not diffused entails other differences between them and light, and these are important. The rays are not diffused, because they do not submit to reflection or to refraction. Their reflection has been thought possible at times, because they were mingled with other elements—for example, ultraviolet rays. M. Gouy has shown with wonderful accuracy that in reality they do not suffer the slightest refraction. They do not exhibit the phenomena of diffraction or of polarization.

Reflection, refraction, diffraction, polarization, and interference are universal characters of ethereal vibrations. They belong to all the rays of the spectrum, from the slowest to the most rapid. They are common to hertzian vibrations, to the infra-red or calorific, to the visible vibrations, and finally to the ultraviolet or chemical vibrations. As to interference, the opinion of the scientific world is divided on the point whether Röntgen rays allow this or not. It appears, however, that the phenomena observed by M. Jaumann, by means of two parallel electrodes connected with the negative pole of the coil by wires of equal length, should be regarded as illustrative of interference.

Is it possible after this to compare Röntgen rays with luminous rays, or even to attribute to them any form of ethereal undulations? This is the general tendency. Wiedemann and Lenard regard them as forming a new round in the spectrum ladder beyond the ultraviolet. Röntgen and Jaumann consider them as the products of longitudinal vibrations of ether.

Röntgen rays discharge electrified bodies placed in their neighborhood. The rudiments of this electrical property are exhibited in the spectrum; ultraviolet rays destroy the negative charges of bodies with which they are brought into contact. This shows a greater or less analogy between the two kinds of radiations. It is only, however, under certain conditions that the Röntgen rays may be referred to small undulations, having the character of undulations of light, and thus continuing the spectrum beyond the violet. It would be necessary to conceive of these undulations as exceedingly short, or what is the same thing, that the vibrations are very rapid, which is a means of rendering the interference less appreciable, and still more so the diffraction. Besides, the velocity of the propagation can not be different in the air and in the other bodies. A priori, this supposition is not improbable—it explains the absence of refraction and renders possible that of reflection. On the other hand, since there is no other way of realizing polarization except through recourse to simple or

double reflection, which are here insufficient, it is not surprising that the Röntgen rays are deprived of this property. Thus deprived of all its burdens and functions it yet possesses transverse vibrations, which place it in the family of spectra; but in these surroundings, after all the diminutions, restrictions, and limitations which it has undergone, it appears rather like a mangy sheep. We have said that some physicists are contented with this state of affairs.

The same difficulties arise if the longitudinal vibrations of the ether are introduced into the theory, and there is added, moreover, the uncertainty of the existence of these vibrations. There is nothing to prove, in truth, that they do not exist; on the contrary, it is evident that they are formed as soon as luminous rays change their direction are reflected or refracted. They could not be neglected except by regarding the ether as strictly incompressible. Some physicists affirm that it is, and, in short, if one relies upon experimental grounds it is sufficient to say that the longitudinal component can be neglected, owing to its insignificance. This is true if one ignores all the phenomena which can accompany the manifestation of light.

In fact, by disregarding the longitudinal vibration, satisfactory agreement, as is known, is found to exist between theory and experiment. It is possible that the Röntgen ray may be due to this longitudinal vibration, but this remains to be proved. Jaumann has endeavored to demonstrate this, but was refuted by M. H. Poincaré.

Besides these explanations there is a third, which consists in saying, with M. A. Schuster, that the vibration of the ether which yields the Röntgen ray is not strictly periodic; periodicity being a condition of interference a troublesome objection is thus removed. On the other hand, explanations founded on the theory of the emission of matter are also problematical. M. Jean Perrin claims that the Röntgen ray is due to the vibration of atomic corpuscles, and is produced by their violent encounter with material molecules. This hypothesis has also the advantage of taking into consideration the conditions of its production. In conclusion, very little is positively known of the nature of this physical agent, which, to quote M. Bouty, has remained exceedingly mysterious in spite of the united efforts of the scientific world.







SIGNOR G. MARCONI, M. INST. C. E.

## WIRELESS TELEGRAPHY.

By Signor G. MARCONI, M. Inst. C. E.<sup>a</sup>

When Ampère threw out the suggestion that the theory of a universal ether, possessed of merely mechanical properties, might supply the means for explaining electrical facts, which view was upheld by Joseph Henry and Faraday, the veil of mystery which had enveloped electricity began to lift. When Maxwell published, in 1864, his splendid dynamical theory of the electro-magnetic field, and worked out mathematically the theory of ether waves, and Hertz had proved experimentally the correctness of Maxwell's hypothesis, we obtained, if I may use the words of Professor Fleming, "the greatest insight into the hidden mechanisms of nature which has yet been made by the intellect of man."

A century of progress such as this has made wireless telegraphy possible. Its basic principles are established in the very nature of electricity itself. Its evolution has placed another great force of nature at our disposal.

We can not pay too high a tribute to the genius of Heinrich Hertz, who worked patiently and persistently in a new field of experimental physics, and made what has been called the greatest discovery in electrical science in the latter half of the nineteenth century. He not only brought about a great triumph in the field of theoretical physics, but, by proving Maxwell's mathematical hypothesis, he accomplished a great triumph in the progress of our knowledge of physical agents and physical laws.

I can not forbear saying one word as to the eminent electrician who was placed in his last home as recently as Saturday last, for it is manifest that several years ago Professor Hughes was on the verge of a great discovery, and, if he had persevered in his experiments, it seems probable that his name would have been closely connected with wireless telegraphy as it is with so many branches of electrical work, in which he gained so much renown and such great distinction.

The experimental proof by Hertz, thirteen years ago, of the identity

<sup>a</sup> Reprinted from Proceedings of the Royal Institution of Great Britain, Vol. XVI, Part II, pp. 247-256. Read at weekly evening meeting, Friday, February 2, 1900, Alexander Siemens, esq., M. Inst. C. E., vice-president, in the chair.

of light and electricity, and the knowledge of how to produce and how to detect these ether waves, the existence of which had been so far unknown, made possible true wireless telegraphy. \* I think I may be justified in saying that for several years the full importance of the discovery of Hertz was realized but by very few, and for this reason the early development of its practical application was slow.

The practical application of wireless telegraphy at the present time is many times as great as the predictions of five years ago led us to expect in so short a time. The development of the art during the past three or four years and its present state of progress may perhaps justify the interest which is now taken in the subject. Yet only a beginning has been made and the possibilities of the future can as yet be only incompletely appreciated. All of you know that the idea of communicating intelligence without visible means of connection is almost as old as mankind. Wireless telegraphy by means of Hertzian waves is, however, very young. I hope that if I pass over the story of the growth of this new art, as I have watched it, or do not attempt to prove questions of priority, no one will take it for granted that nothing is to be said on these subjects, or that all that has been said is entirely correct.

The time allowed for this discourse is too short to permit me to recount all the steps that have led up to the practical applications of to-day. I believe it will probably interest you more to hear of the problems which have lately been solved, and the very interesting developments which have taken place during the last few months.

I find that a great element of the success of wireless telegraphy is dependent upon the use of a coherer such as I have adopted. It has been my experience, and that of other workers, that a coherer as previously constructed—that is, a tube several inches long partially filled with filings inclosed by corks—was far too untrustworthy to fulfill its purpose. I found, however, that if specially prepared filings were confined in a very small gap (about 1 mm.) between flat plugs of silver, the coherer, if properly constructed, became absolutely trustworthy. In its normal condition the resistance of a good coherer is infinite, but when influenced by electric waves the coherer instantly becomes a conductor, its resistance falling to 100 or 500 ohms. This conductivity is maintained until the tube is shaken or tapped.

I noticed that by employing similar vertical and insulated rods at both stations it was possible to detect the effects of electric waves of high frequency, and in that way convey the intelligible alphabetical signals over distances far greater than had been believed to be possible a few years ago.

I had formerly ascertained<sup>a</sup> that the distance over which it is possi-

---

<sup>a</sup> See paper read before the Institution of Electrical Engineers by G. Marconi, March, 1899.

ble to signal with a given amount of energy varies approximately with the square of the height of the vertical wire, and with the square root of the capacity of a plate, drum, or other form of capacity area which may be placed at the top of the wires.

The law governing the relation of height and distance has already been proved correct up to a distance of 85 miles. Many months ago it was found possible to communicate from the North Haven, Poole, to Alum Bay, Isle of Wight, with a height of 75 feet, the distance being 18 miles. Later on two installations with vertical wires of double that length, i. e. 150 feet, were erected at a distance of 85 miles apart, and signals were easily obtained between them. According to a rigorous application of the law, 72 miles ought to have been obtained instead of 85; but as I have previously stated, the law has been proved only to be approximately correct, the tendency being always on what I might call the right side; thus we obtain a greater distance than the application of the law would lead us to believe. There is a remarkable circumstance to be noted in the case of the 85 miles signaling. At the Alum Bay station the mast is on the cliff, and there is no curvature of the earth intervening between the two stations; that is to say, a straight line between the base of the Haven and Alum Bay stations would clear the surface of the sea. But in the case of the 85 miles the two stations were located on the sea level, and between them exists a hill of water, owing to the earth's curvature, amounting to over 1,000 feet. If those waves traveled only in straight lines, or the effect was noticeable only across open space, in a direct line, the signals would not have been received except with a vertical wire 1,000 feet high at both stations.

While carrying out some experiments nearly three years ago at Salisbury, Captain Kennedy, R. E., and I tried numerous forms of induction coils wound in the ordinary way, that is, with a great number of turns of wire on the secondary circuit, with the object of increasing, if possible, the distance or range of transmission; but in every case we observed a very marked decrease in the distance obtainable with the given amount of energy and height. Similar results were obtained some months later, I am informed, in experiments carried out by the general post-office engineers at Dover.

In all our above-mentioned experiments the coils used were those in which the primary consisted of a smaller or larger number of turns of comparatively thick wire, and the secondary of several layers of thinner wire. I believe I am right saying that hundreds of these coils were tried, the result always being that by their employment the possible distance of signaling was considerably diminished instead of being increased. We eventually found an entirely new form of induction coil that would work satisfactorily, and that began to increase the distance of signaling.

The results given by some of the new form of induction coils have

been remarkable. During the naval maneuvers I had an opportunity of testing how much they increased the range of signaling with a given amount of energy and height. When working between the cruisers *Juno* and *Europa*, I ascertained that when the induction coil was omitted from the receiver, the limit distance obtainable was 7 miles, but with an improved form of induction coil included, a distance of over 60 miles could be obtained with certainty. This demonstrated that the coils I used at that time increased the possible distance nearly tenfold. I have now adopted these induction coils, or transformers, at all our permanent stations.

A number of experiments have been carried out to test how far the Wehnelt brake was applicable in substitution for the ordinary make and brake of the induction coil at the transmitting station; but although some excellent results have been obtained over a distance of 40 miles of land, the amount of current used and the liability of the brake getting fatigued or out of order have been obstacles which have so far prevented its general adoption.

As is probably known to most of you, the system has been in practical daily operation between the East Goodwin light-ship and the South Foreland light-house since December 24, 1898, and I have good reason for believing that the officials of Trinity House are convinced of its great utility in connection with light-ships and light-houses. It may be interesting to you to know that, as specially arranged by the authorities of Trinity House, although we maintain a skilled assistant on the light-ship, he is not allowed to work on the telegraph. The work is invariably done by one of the seamen on the light-ship, many of whom have been instructed in the use of the instrument by one of my assistants. On five occasions assistance has been called for by the men on board the ship, and help obtained in time to avoid loss of life and property. Of these five calls for assistance, three were for vessels run ashore on the sands near the light-ship, one because the light-ship herself had been run into by a steamer, and one to call a boat to take off a member of the crew who was seriously ill.

In the case of a French steamer which went ashore off the Goodwins, we have evidence, given in the admiralty court, that by means of one short wireless message property to the amount of £52,588 was saved; and of this amount, I am glad to say, the owners and crews of the lifeboats and tugs received £3,000. This one saving alone is probably sufficient in amount to equip all the light-ships round England with wireless telegraph apparatus more than ten times over. The system has also been in constant use for the official communication between the Trinity House and the ship, and is also used daily by the men for private communication with their families, etc.

It is difficult to believe that any person who knows that wireless telegraphy has been in use between this light-ship and the South Fore-

land day and night, in storm and sunshine, in fog and in gales of wind, without breaking down on any single occasion, can believe or be justified in saying that wireless telegraphy is untrustworthy or uncertain in operation. The light-ship installation is, be it remembered, in a small damp ship, and under conditions which try the system to the utmost. I hope that before long the necessary funds will be at the disposal of the Trinity House authorities, in order that communication may be established between other light-ships and light-houses and the shore, by which millions of pounds' worth of property and thousands of lives may be saved.

At the end of March, 1899, by arrangement with the French Government, communication was established between the South Foreland light-house and Wimereux, near Boulogne, over a distance of 30 miles, and various interesting tests were made between these stations and French war ships. The maximum distance obtained at that time, with a height of about 100 feet on the ships, was 42 miles. The commission of French naval and military officers who were appointed to supervise these experiments, and report to their Government, were in almost daily attendance on the one coast or the other for several weeks. They became intensely interested in the operations, and I have good reasons to know made satisfactory reports to their Government. I can not allow this opportunity to pass without bearing willing testimony to the courtesy and attention which characterised all the dealings of these French gentlemen with myself and staff.

The most interesting and complete tests of the system at sea were, however, made during the British naval maneuvers. Three ships of the "B" fleet were fitted up—the flagship *Alexandra* and the cruisers *Juno* and *Europa*. I do not consider myself quite at liberty to describe all the various tests to which the system was put, but I believe that never before were Hertzian waves given a more difficult or responsible task. During these maneuvers I had the pleasure of being on board the *Juno*, my friend, Captain Jackson, R. N., who had done some very good work on the subject of wireless telegraphy before I had the pleasure of meeting him, being in command. With the *Juno* there was usually a small squadron of cruisers, and all orders and communications were transmitted to the *Juno* from the flagship, the *Juno* repeating them to the ships around her. This enabled evolutions to be carried out even when the flagship was out of sight. This would have been impossible by means of flags or semaphores. The wireless installations on these battleships were kept going night and day, most important maneuvers being carried out and valuable information telegraphed to the admiral when necessary.

The greatest distance at which service messages were sent was 60 nautical miles, between the *Europa* and the *Juno*, and 45 miles, between the *Juno* and the *Alexandra*. This was not the maximum

distance actually obtained, but the distance at which, under all circumstances and conditions, the system could be relied upon for certain and regular transmission of service messages. During tests messages were obtained at no less than 74 nautical miles (85 land miles).

As to the opinion which naval experts have arrived at concerning this new method of communication, I need only refer to the letters published by naval officers and experts in the columns of *The Times* during and after the period of the autumn maneuvers, and to the fact that the admiralty are taking steps to introduce the system into general use in the navy.

As you will probably remember, victory was gained by the "B" fleet, and perhaps I may venture to suggest that the facility which Admiral Sir Compton Domville had of using the wireless telegraph in all weathers, both by day and night, contributed to the success of his operations.

Commander Statham, R. N., has published a very concise description of the results obtained in the Army and Navy, illustrated, and I think it will be interesting if I read a short extract from the admirable description he has published:

"When the reserve fleet first assembled at Tor Bay, the *Juno* was sent out day by day to communicate at various distances with the flagship, and the range was speedily increased to over 30 miles, ultimately reaching something like 50 miles. At Milford Haven the *Europa* was fitted out, the first step being the securing to the main topmast head of a hastily prepared spar carrying a small gaff or sprit, to which was attached a wire, which was brought down to the starboard side of the quarter-deck through an insulator and into a roomy deck house on the lower afterbridge which contained the various instruments.

"When hostilities commenced, the *Europa* was the leading ship of a squadron of 7 cruisers dispatched to look for the convoy at the rendezvous. The *Juno* was detached to act as a link when necessary and to scout for the enemy, and the flagship of course remained with the slower battle squadron. The *Europa* was in direct communication with the flagship long after leaving Milford Haven, the gap between reaching to 30 or 40 miles before she lost touch while steaming ahead at a fast speed. (This difference between the ranges of communication on these ships was owing to the *Juno* having a higher mast than the *Alexandra*.)

"Reaching the convoy at 4 o'clock one afternoon, and leaving it and the several cruisers in charge of the senior captain, the *Europa* hastened back toward another rendezvous, where the admiral had intended remaining until he should hear whether the enemy had found and captured the convoy; but scarcely had she got well ahead of the slow ships when the *Juno* called her up and announced the admiral coming to meet the convoy. The *Juno* was at this time fully 60 miles distant from the *Europa*.

"Now imagine," says Commander Statham, "a chain of vessels 60 miles apart. Only five would be necessary to communicate some vital piece of intelligence a distance of 300 miles, receive in return their instructions, and act immediately all in the course of half an hour or



less. This is possible already. Doubtless a vast deal more will be done in a year or two or less, and meanwhile the authorities should be making all necessary arrangements for the universal application of wireless telegraphy in the navy."

The most important results, from a technical point of view, obtained during the maneuvers were the proof of the great increase of distance obtained by employing the transformer in the receiver, as already explained, and also that the curvature of the earth which intervened, however great the distance attained, was apparently no obstacle to the transmission. The maximum height of the top of the wire attached to the instruments above the water did not on any occasion exceed 170 feet, but it would have been geometrically necessary to have had masts 700 feet high on each ship in order that a straight line between their tops should clear the curved surface of the sea when the ships were 60 nautical miles apart. This shows that the Hertzian waves had either to go over or round the dome of water 530 feet higher than the tops of the masts, or to pass through it, which latter course I believe would be impossible.

Some time after the naval maneuvers, with a view to showing the feasibility of communicating over considerable distances on land, it was decided to erect two stations, one at Chelmsford and another at Harwich, the distance between them being 40 miles. These installations have been working regularly since last September, and my experiments and improvements are continually being carried out at Chelmsford, Harwich, Alum Bay, and North Haven, Poole.

In the month of September last, during the meetings of the British Association in Dover and of the Association Française pour l'avancement de Science in Boulogne, a temporary installation was fixed in the Dover town hall, in order that members present should see the practical working of the system between England and France. Messages were exchanged with ease between Wimereux, near Boulogne, and Dover town hall. In this way it was possible for the members of the two associations to converse across the channel, over a distance of 30 miles.

During Professor Fleming's lecture on the Centenary of the Electric Current, messages were transmitted direct to and received from France, and via the South Foreland light-house to the East Goodwin light-ship. An interesting point was that it was demonstrated that the great masses of the Castle Rock and South Foreland cliffs lying between the town hall, Dover, and the light-house did not in the least degree interfere with the transmission of signals. The result was, however, by no means new. It only confirmed the results of many previous experiments, all of them showing that rock masses of very considerable size intervening between two stations do not in the least affect the freedom of communication by ether wave telegraphy.<sup>a</sup>

<sup>a</sup>See Journal of the Institution of Electrical Engineers, April, 1899, p. 280.

It was during these tests that it was found possible to communicate direct from Wimereux to Harwich or Chelmsford, the intervening distance being 85 miles. This result was published in a letter from Professor Fleming addressed to the Electrician on September 29. The distance from Wimereux to Harwich is approximately 85 miles, and from Wimereux to Chelmsford also 85 miles, of which 30 miles are over sea and 55 over land. The height of the poles at these stations was 150 feet, but if it had been necessary for a line drawn between the tops of the masts to clear the curvature of the earth, they would have had to have been over 1,000 feet high. I give these results to show what satisfactory progress is being made with this system.

In America wireless telegraphy was used to report from the high seas the progress of the yachts in the international yacht race, and I think that occasion holds the record for work done in a given time, over 4,000 words being transmitted in the space of less than five hours on several different days.

Some tests were carried out for the United States Navy; but, owing to insufficient apparatus, and to the fact that all the latest improvements had not been protected in the United States at that time, it was impossible to give the authorities there such a complete demonstration as was given to the British authorities during the naval maneuvers. Messages were transmitted between the battle ship *Massachusetts* and the cruiser *New York* up to a distance of 36 miles.

A few days previous to my departure from America the war in South Africa broke out. Some of the officials of the American line suggested that, as a permanent installation existed at the Needles, Isle of Wight, it would be a great thing, if possible, to obtain the latest war news before our arrival on the *St. Paul* at Southampton. I readily consented to fit up my instruments on the *St. Paul*, and succeeded in calling up the Needles station at a distance of 66 nautical miles. By means of wireless telegraphy, all the important news was transmitted to the *St. Paul* while she was underway, steaming 20 knots, and messages were despatched to several places by passengers on board. News was collected and printed in a small paper called the *Transatlantic Times* several hours before our arrival at Southampton.

This was, I believe, the first instance of the passengers of a steamer receiving news while several miles from land, and seems to point to a not far distant prospect of passengers maintaining direct and regular communication with the land they are leaving and with the land they are approaching, by means of wireless telegraphy.

At the tardy request of the war office, we sent out Mr. Bullocke and five of our assistants to South Africa. It was the intention of the war office that the wireless telegraph should only be used at the base and on the railways, but the officers on the spot realized that it could only be of any practical use at the front. They therefore asked Mr. Bullocke whether he was willing to go to the front.

As the whole of the assistants volunteered to go anywhere with Mr. Bullocke, their services were accepted, and on December 11 they moved up to the camp at De Aar. But when they arrived at De Aar, they found that no arrangements had been made to supply poles, kites, or balloons, which, as you all know, are an essential part of the apparatus, and none could be obtained on the spot. To get over the difficulty, they manufactured some kites, and in this they had the hearty assistance of two officers, viz. Major Baden-Powell and Captain Kennedy, R. E., who have often helped me in my experiments in England. (Major Baden-Powell, it will be remembered, is a brother of the gallant defender of Mafeking.)

The results which they obtained were not at first altogether satisfactory, but this is accounted for by the fact that the working was attempted without poles or proper kites, and afterwards with poles of insufficient height, while the use of the kites was very difficult, the kites being manufactured on the spot with very deficient material. The wind being so variable, it often happened that when a kite was flying at one station there was not enough wind to fly a kite at the other station with which they were attempting to communicate. It is therefore manifest that their partial failure was due to the lack of proper preparation on the part of the local military authorities, and has no bearing on the practicability and utility of the system when carried out under normal conditions.

It was reported that the difficulty of getting through from one station to another was due to the iron in the hills. If this had not been cabled from South Africa, it would hardly be credible that any one should have committed himself to such a very unscientific opinion. As a matter of fact, iron would have no greater destructive effect on these Hertzian waves than any other metal, the rays apparently getting very easily around or over such obstacles. A fleet of 30 ironclads did not affect the rays during the naval maneuvers, and during the yacht race I was able to transmit my messages with absolute success across the very high buildings of New York, the upper stories of which are iron.

However, on getting the kites up, they easily communicated from De Aar to Orange River, over a distance of some 70 miles. I am glad to say that, from later information received, they have been able to obtain poles, which although not quite high enough for long distances are sufficiently useful. We have also sent a number of Major Baden-Powell's kites, which are the only ones I have found to be of real service.

Stations have been established at Modder River, Enslin, Belmont, Orange River, and De Aar, which work well and will be invaluable in case the field telegraph line connecting these positions should be cut by the enemy.

It is also satisfactory to note that the military authorities have

lately arranged to supply small balloons to my assistants for portable installations on service wagons.

While I admire the determination of Mr. Bullocke and our assistants in their endeavor to do the very best they could with most imperfect local means, I think it only right to say that if I had been on the spot myself I should have refused to open any station until the officers had provided the means for elevating the wire, which, as you know, is essential to success.

Mr. Bullocke and another of our assistants in South Africa have been transferred, with some of the apparatus, to Natal to join General Buller's forces, and it is likely that before the campaign is ended wireless telegraphy will have proved its utility in actual warfare. Two of our assistants bravely volunteered to take an installation through the Boer lines into Kimberley; but the military authority did not think fit to grant them permission, as it probably involved too great a risk.

What the bearing on the campaign would have been if working installations had been established in Ladysmith, Kimberley, and Mafeking before they were besieged, I leave military strategists to state. I am sure you will agree with me that it is much to be regretted that the system could not be got into these towns prior to the commencement of hostilities.

I find it hard to believe that the Boers possess any workable instruments. Some instruments intended for them were seized by the authorities at Cape Town. These instruments turned out to have been manufactured in Germany. Our assistants, however, found that these instruments were not workable. I need hardly add that as no apparatus has been supplied by us to anyone, the Boers can not possibly have obtained any of our instruments.

I have spoken at great length about the things which have been accomplished. I do not like to dwell upon what may or will be done in the immediate or more distant future, but there is one thing of which I am confident, viz, that the progress made this year will greatly surpass what has been accomplished during the last twelve months; and, speaking what I believe to be sober sense, I say that by means of the wireless telegraph, telegrams will be as common and as much in daily use on the sea as at present on land.

---

[Mr. Marconi's experiments in trans-Atlantic telegraphing were thus described in the *New York Herald* of Sunday, December 15, and Tuesday, December 17, 1901:

[Extract from *New York Herald*, December 15, 1901.]

ST. JOHNS, NEWFOUNDLAND, *Saturday, December 14.*

Mr. Marconi announced to-day that he has successfully received by wireless telegraphy, at the station on Signal Hill, messages from the

station recently erected near the Lizard, in Cornwall, England. These messages, Mr. Marconi said, were received on Wednesday and Thursday afternoons. He had arranged with the Cornwall station that the letter "S" was to be signaled at 6 o'clock in the evening, which would be half-past 2 o'clock here, and signals were received as arranged on Wednesday and Thursday, though no signal came yesterday or to-day.

#### MR. MARCONI DESCRIBES THE TEST.

"I thought it advisable," said Mr. Marconi, "with the machinery which had escaped damage at Cornwall, to see whether it was possible to obtain signals here from England at the same time I tried experiments with trans-Atlantic liners.

"When the kite elevated the wire to a height of 400 feet above Signal Hill on Wednesday a number of signals, consisting of the letter 'S,' which signal was ordered to be sent from Cornwall, were clearly received on Signal Hill by the receiving instruments. We again received the signals perfectly on Thursday.

"The signals were obtained only when the kite was up to a considerable height. For some reason yesterday nothing was received, and to-day we could not get the kite up on account of the weather. It has been blowing too heavily every day for balloons, which would be best to experiment with.

#### SUCCESS HAS ALTERED HIS PLANS.

"The success of these tests will alter my plans. I intend to suspend further tests with kites and balloons for a short time and erect a large station here, at a cost of \$50,000, having towers, or masts, for supporting wires. This, of course, provided there is no governmental or other objection. This will necessitate my going back to England at the end of next week in order to have the necessary equipments sent here, with suitable transmitting machinery and other requirements.

"By that time I hope to have the Cape Cod Station in working order again, so as to complete a regular triangular service. No doubt the success of my experiments here will cause a sensation in telegraphic circles, and many will find it difficult to believe it.

"I myself had very little doubt as to our ultimate success, but I thought it advisable not to communicate beforehand the exact scope of these tests, as I considered it would be better to assure myself of success before publishing details even of installations at Cornwall and Cape Cod, and what we hoped to accomplish by them. It is right, however, that the public should now know of the grand result of my experiments here.

"I hope in the course of a few months to have a system of direct communication across the Atlantic in working order, and it can then be easily ascertained whether the discovery is of practical use for commercial and other purposes. I have no doubt in the matter, but I am content to wait and let events prove that I am correct in my belief.

"The instruments I have at present are extremely sensitive, and I am of the opinion that in order to make the signals absolutely reliable it will be necessary to arrange for more power at the sending station in Cornwall, which I will arrange for on my return to England."

Mr. Marconi's company about a year ago decided to put up two very large stations, at a cost of \$70,000 each, at Cape Cod, Massachusetts, and near the Lizard, in Cornwall, England, the object being to ascertain how much an application of a large amount of power would increase the practical distance by which it is possible to communicate by wireless telegraphy.

The stations in Cornwall and Cape Cod consisted of heavy machinery and 20 poles, 210 feet high, supporting a large number of vertical wires. The station in Cornwall was practically destroyed during a heavy gale in September, and was only partially renewed. It will not be completely repaired for another two or three months. The Cape Cod Station was also damaged recently.

ST. JOHNS, NEWFOUNDLAND, *Saturday*.

Confirm that signals were received here Thursday and Friday direct from Cornwall, receiving wire suspended from a kite.

MARCONI.

[From the New York Herald, December 17, 1901.]

*To the Editor of the New York Herald:*

I have to confirm the dispatch of your correspondent regarding the receipt by me here of signals direct from Cornwall. The exact particulars are as follows:

Before leaving England I arranged for our long distance station near the Lizard to signal me the letter "S" repeatedly for three hours when I had advised them that I was ready to receive the same. I cabled on Monday that all was in readiness and asked the signal to be sent at short intervals between 3 o'clock and 6 o'clock, Greenwich time, and to be continued each day until ordered to stop. This time would correspond approximately with half past 11 to half past 2 here.

I received on Thursday indications of the signals at half past 12, and with certainty and unmistakable clearness at 10 minutes after 1 quite a succession of "S" being received with distinctness. A further number were received at 20 minutes after 2, the latter not so good. Signals were received Friday at 28 minutes after 1 o'clock, but not so distinct as on Thursday.

I am of the opinion that the reasons why I did not obtain continuous results, were: First, the fluctuations in the height of the kite, which suspended the aerial wire; and second, the extreme delicacy of my receiving instruments, which were very sensitive and had to be adjusted repeatedly during the course of the experiments.

When a permanent station is installed here I will not be dependent upon fluctuations of the wind, and I am confident of making the signals strong and reliable—that is, not requiring such delicate and sensitive receiving instruments by employing much greater power at the sending station.

I must go immediately to England to make arrangements for employing more power at the sending station, and I trust in a very short time to establish communication between the two continents in a thoroughly reliable and commercial manner.

MARCONI.]

ST. JOHNS, NEWFOUNDLAND, *December 16, 1901.*

## TRANSATLANTIC TELEPHONING.<sup>a</sup>

THE REMARKABLE INVENTION BY WHICH DR. M. I. PUPIN HAS REVOLUTIONIZED THE TRANSMISSION OF ELECTRICITY.

---

BY WILLIAM A. ANTHONY,

*Former President of the American Institute of Electrical Engineers.*

---

At last the problem of telephoning over long-distance lines and ocean cables has been solved, and we may hope soon to be able to talk across the ocean and recognize the voice of a friend as he replies to us from London or Paris.

Dr. M. I. Pupin, of Columbia University, after years of patient labor, has pointed out the way where others had failed, and has accomplished what many had believed to be impossible.

To appreciate the importance of what Dr. Pupin has done, it is well to contrast the two problems of transmitting telegraph messages on the one hand, and of transmitting telephone messages on the other. In transmitting a telegraph message, the sender closes and opens a key that makes and breaks an electric circuit, sending to the line electric impulses that magnetize little pieces of soft iron, and so operate a lever in the receiving instrument in unison with the key. The alphabet is a combination of dots and dashes. When the key is closed for an instant only, a very short electric impulse travels along the line, causing a momentary attraction and depression of the lever, which is recognized as a dot. When the key is held closed for a little time the lever is held down for a corresponding period and records a dash. When the line is long and the electric impulses become weak, so that the lever responds feebly, a new source of current is introduced; a new "circuit" is established, extending on to the more distant point, and the lever of the receiving instrument in the first circuit is made to open and close this second circuit exactly as did the key at the beginning. So the message is given to the new circuit with renewed energy, and goes on again to produce a legible record at double the distance from the sending station. When the receiving instrument is made

---

<sup>a</sup>Reprinted, by courtesy of Doubleday, Page & Co., from Everybody's Magazine, Vol. IV, April, 1901. Copyrighted.

thus to open and close a new circuit, it is called a repeater, and on a land line such repeaters may be introduced as often as may be necessary to transmit the message as far as we please.

On an ocean cable, however, it is impossible to introduce repeaters, and the only thing to be done is to construct receiving instruments of extreme delicacy, capable of responding to the greatly enfeebled electric impulses. But the impulses on an ocean cable are not merely enfeebled. There is another difficulty more serious still. In consequence of what is called the capacity of the cable, the impulses are spread out or prolonged, so that a momentary impulse started at the sending end reaches the receiving end much prolonged. It may help to an understanding of what takes place if we consider a case more in line with every day experience. Suppose we try to transmit messages by sending puffs of air into a long tube. It is evident that we should succeed better if the tube be narrow than if it be widened into a chamber of considerable capacity where the puffs sent into the tube would make little impression, and where they would find room to spread out and become not only enfeebled, but prolonged. An ocean cable is just such a chamber or reservoir for electric impulses. It has a large capacity for an electric charge. Such impulses as we use on land lines make little impression upon it, and such effects as are produced at the receiving end are so prolonged that they lose all their character as dots and dashes. It is possible, however, to adopt our sending to this condition. We can wait. We can allow a sufficient interval between the successive impulses to give time for each to produce its effect at the receiving end. On an ocean cable we can telegraph, but we must telegraph slowly.

Very different is the problem of transmitting speech. Everyone knows that audible sound is the result of vibrations in the air. The differences that we recognize between sounds must be due to differences between these vibrations or sound waves. To each sound must correspond its own sound wave, distinctly different from all the others. It is wonderful, even when the air alone is the medium, that these distinctive differences should be preserved and that we should be able to recognize such a great variety of sounds. It is still more wonderful when we study the sound waves and find in what small differences the distinction between different sounds consists. Far more wonderful still is it when we consider all that must take place in the several transformations between the speaker and the hearer when sound is transmitted by telephone.

We speak against a thin sheet-iron disk a little larger than a dollar. The vibration is communicated to the disk, and this, through a delicately adjusted mechanism, gives rise to electric waves which traverse the wire and, in the receiving instrument, produce vibrations in another disk, which communicates them to the air and so to the ear. Through



these various transformations all the distinctive characteristics of the sound must be preserved. The vibrations of the transmitter disk, the electric waves that traverse the wire, the vibrations produced in the receiver disk, must retain all the elements that characterized the original vocal sounds. This must be, or we could not, as we do, recognize not only the spoken words, but the tone and modulations of the voice, and even the mood of the speaker. The imperfections of electrical conductors not only tend to enfeeble, but to distort the electric waves, and a little distortion is sufficient to change the character of the sound as it is reproduced, and render it unrecognizable. What is meant by a distorted wave may be seen from fig. 1, where *a* may represent a wave as given to a telephone line, and *b*, *c*, *d* the same wave which has become distorted by a change in the relation of its elements during transmission; *d* would hardly be recognized as having anything in common with *a*.

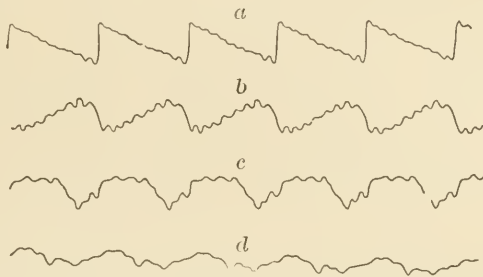

FIG. 1.

Let us consider a little further the effect of the conducting line upon the waves that transmit speech. Speak the words "soap" and "soup," "mine" and "mean." How do you make the distinction? By a little more or less opening of the mouth, and a little more or less pursing of the lips. Helmholtz has shown us in what respect the corresponding sound waves differ. It appears that it is only in the little waves superimposed upon the main wave, in the little ripples, so to speak, on the surface of the larger wave. The wave for the "ou" in "soup" might look like this:



FIG. 2.

And the wave for the "o" in "soap," like this:



FIG. 3.

The ear distinguishes the difference between these much better than the eye.

The effect of the long telephone line upon these waves is something like this:



FIG. 4.

The little ripples that distinguish the sounds die out before the main wave. Such changes as these render repeaters useless on a telephone wire, for no repeater can restore characteristics that have already been lost. On an ocean cable this dying out occurs more quickly than on a land line; and, besides, the main wave is distorted and flattened so as to lose its identity altogether.

This was the situation in long-distance telephony when Dr. Pupin attacked the problem six or seven years ago. While tramping through Switzerland in 1894 he improved his spare moments by reading Lord Rayleigh on the theory of sound. That part relating to the vibration of strings led him to consider the telephone problem. Suppose a long string attached to a mechanism which can only be operated by transverse jerks of the string. If the end of the string at a distance from the mechanism be moved back and forth, waves will travel along it, and may supply the jerks required to operate the mechanism. But if the string be very light, and the resistance to its motion great—if, for instance, it were in a tank of water—the waves impressed upon it would rapidly die out, and it might be necessary to swing the string back and forth with all the violence at our command, in order that they should reach the mechanism at all. Substitute a heavy string for the light one. Waves imparted to it will have a much greater power of persistence. It will be necessary to impart a much less violent motion, and this of itself reduces very much the effect of the resistance of the medium in which the string swings. But we need not use a string that is uniformly heavy. The effect of the heavy string may be closely imitated by distributing heavy masses along it at intervals.

Dr. Pupin set himself to solve the problem of the behavior of such a loaded string in a resisting medium. Its solution had not been before attempted, for its tremendous intricacy would baffle anyone who had not at command, as Dr. Pupin has, the resources of the "higher mathematics." Many perplexing questions are involved. Given a certain amount of energy, to be transmitted by means of a string swinging in a given resisting medium, how heavy must be the masses? How near together must they be placed? Can they be so placed and proportioned that they will serve equally well for the transmission of long or short waves; that is, of slow or rapid vibratory motions?

It will be asked what this has to do with the transmission of speech over long telephone lines. Speech is transmitted by electric waves, and waves are waves, subject to similar laws, whether they occur in a stretched cord, or in an elastic fluid, or in an electric current. From energy transmitted by waves in a cord, to energy transmitted by waves in an electric current, is only a step. It has long been known that a conductor wound in a close coil gives to an electric current in it something of the properties of a massive body. It is hard to start a current in such a coil, but once started, it is just as hard to stop it. Coils placed along a telephone line will have an effect similar to the masses along the cord. Electric waves started on such a line will be persistent waves, they will not die out, they will retain their form and characteristics. With such an aid the New Yorker can ask of his Chicago correspondent, "What will that mine cost?" without fear that he will understand it: "Who was that man ——?"

But this is not the whole story. Let us go back to the weighted cord. It is plain that a small motion, a comparatively slow movement, given to the heavy masses would be the equivalent of a much more rapid movement given to the cord alone. Slow movements always mean small losses. The cost of carrying a ton from New York to Chicago on a slowly moving freight train is far less than of carrying the same on the high-speed passenger train. The slowly moving, heavily weighted cord will carry from end to end the power imparted to it with little loss in the resisting medium.

So it is with the electric currents in Dr. Pupin's line. It is a heavily weighted current. A very little current, with the high pressure it can exert in consequence of the action of the coils, may convey as much power as a much larger current on an ordinary line. Now, every electrician knows that the loss of power occurring on a conductor is proportional to the square of the current—that is, if you have only half the current there is but one-fourth the loss: one-fourth the current, one-sixteenth the loss, etc. Every electrician knows, too, that the same power may be transmitted by a small current by increasing the electric pressure just in proportion as the current is reduced. This is recognized wherever electric transmission is employed. At Niagara power is transmitted to near-by points at a pressure of 2,000 volts; but on the line to Buffalo 10,000 volts is employed, requiring only one-fifth the current, and therefore one-twenty-fifth the loss if the same conductors were used. In California, where power is to be carried 150 miles, a pressure of 60,000 volts will be employed. Dr. Pupin's line is another case of transmission by high pressure and small current, and consequently small losses and little attenuation of the waves.

It has been said already that Dr. Pupin arrived at his results by mathematical investigation. There was no haphazard experimenting,

no groping in the dark, no lucky discovery. Different forms of apparatus were tried, to be sure, but all were based upon the results of the mathematical analysis. The last form has the advantage that it is an exact representation of a standard telephone line with coils arranged to be inserted every mile at pleasure.

Fig. 5 (Pl. I) is a general view of apparatus which Dr. Pupin has used in his experiments. On the left is seen one of the 50-mile sections of this line. Other sections are seen in full or in part, in front and on the left and right. The line proper is contained in the large case standing on top of the frame, and consists of tin-foil strips of such width and length as to have the resistance and in such relation as to have the capacity of the standard line. This makes an artificial line, having all the characteristics of the standard telephone line, except the length. This line is subdivided into 50 sections, each equivalent to one mile of standard line. The ends of these are seen in the maze of wire going from the case to the frame below. On this frame are the 50 coils, which may be included in the line or left out of it by removing or inserting plugs. With the coils out of circuit, telephone conversation is distinct up to 30 miles, can be barely made out at 100, and is absolutely unrecognizable at 110 miles. Introducing the coils, the conversation becomes again perfectly distinct and continues so through all the sections, equivalent to 250 miles of line.

Fig. 6. (Pl. I) shows a larger view of one of these 50-mile sections, and in the foreground a small generator of alternating currents of 600 periods per second, corresponding to about the average frequency of the vibrations of the human voice. This generator was used for producing electric waves for comparing the actual with the theoretical results. From the resistance and capacity of the artificial line, and the resistance and self-induction of the coils, the velocity of transmission, and the length of the electric waves corresponding to 600 periods per second, were computed.

The first computation gave for the wave length about 26 miles. A measurement of the wave length gave about 18 miles. Here was a wide discrepancy between the theoretical and measured lengths, too great a discrepancy to be ascribed to any ordinary error of measurement. And since, of course, the wave length determines the proper distance which should be between these coils in actual work, the matter was one of prime importance. All the measurements of resistance, capacity, and self-induction were repeated without finding any errors. The generator was thoroughly studied to see that it really gave a frequency of 600 periods. All the apparatus for measuring the wave lengths was subjected to a rigid examination and analysis, to see if any error could be introduced there. The computations were reviewed again and again, with always the same result of 26 miles for the wave lengths. Means were provided for maintaining a per-

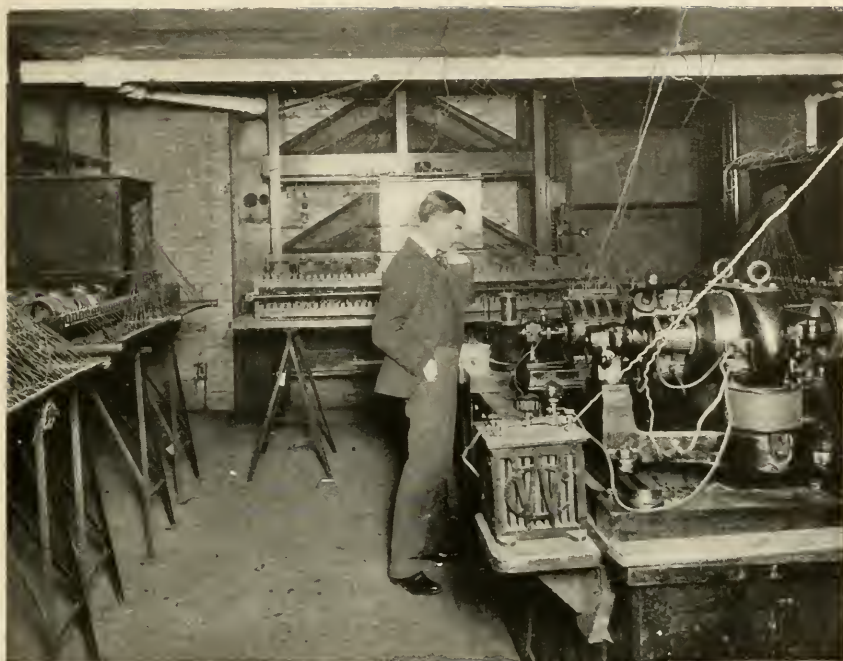

FIG. 5.—GENERAL VIEW OF APPARATUS USED BY DR. PUPIN.

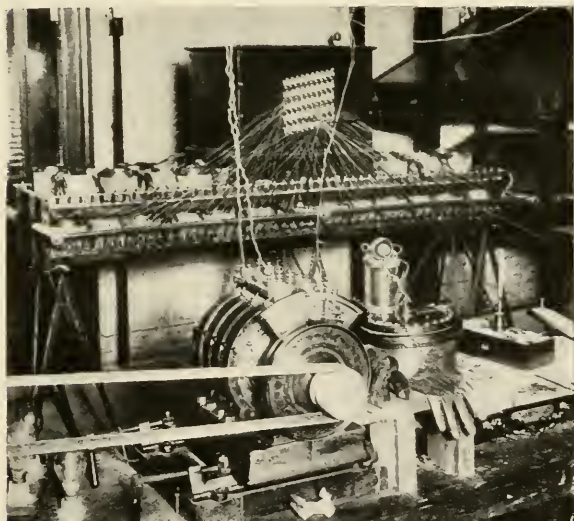

FIG. 6.—LARGER VIEW OF 50-MILE SECTION OF LINE SEEN ON THE LEFT OF FIG. 5.





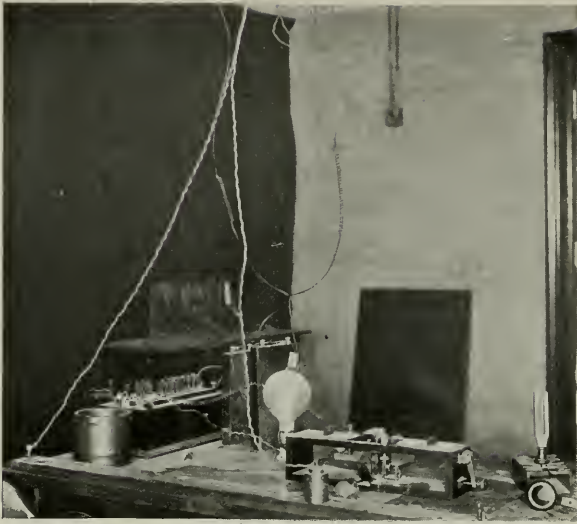

FIG. 7.—DEVICE FOR PRESERVING UNIFORM FREQUENCY OF ALTERNATIONS.

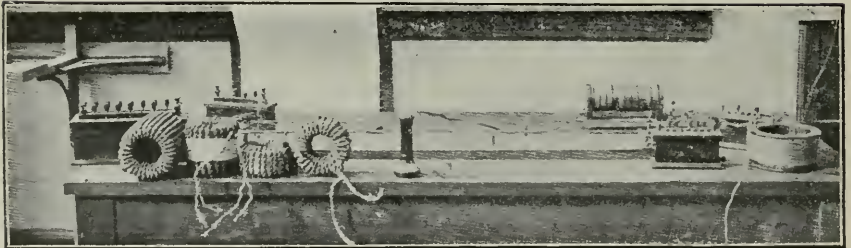

FIG. 8.—COILS SIMILAR IN SIZE AND SHAPE TO THOSE WHICH WILL BE USED ON LAND LINES AND UNDERGROUND CABLES, BUT WOUND WITH DIFFERENT WIRE.



fectly uniform speed of the generator, in order to preserve a uniform frequency of alternations. (This of itself was a very ingenious device, and is worth a brief description. It is shown upon the table in fig. 7 (Pl. II.) A stretched piano wire was arranged to be kept in vibration by magnetic impulses. It emitted a continuous note which was tuned to unison with a standard tuning fork, seen on the right. A telephone connected in circuit with the generator emitted a note corresponding to the frequency of the alternating current which the generator produced. Stretched along the front edge of the table was a resistance wire connected with the electric motor which drove the generator. By varying the resistance of this wire, by sliding along it the weight seen resting upon it, the speed of the generator and the number of alterations per second could be varied. An assistant sat at this table with the telephone at his ear, and, by varying this resistance, endeavored to keep the telephone note in unison with that of the piano wire.) With all these refinements the measured wave-length still came out 18 miles. All these remeasurements and recomputations took about three weeks, and it began to look as though the reconciliation of theory with experiment was hopeless. At last, after going over the computations many times, it was discovered that a factor, the square root of two, had been overlooked in the denominator of one of the fractions. Dividing the 26 miles by this gave for the theoretical wave length about 18 miles, agreeing with the measured wave length to about one-tenth of 1 per cent. This wave length of 18 miles corresponds to a velocity of transmission of these electric waves of 10,800 miles per second.

On the table in fig. 8 (Pl. II), at the left, are shown some coils similar in size and shape to those which will be used on land lines and underground cables, but wound with different wire. On land lines they would be placed on top of poles at intervals of one to two miles. On ocean cables the coils would be much smaller, and placed only about one-eighth of a mile apart. They would be inclosed in the protecting sheath, and would appear as swellings on the cable. They add but a small fraction of one per cent to the weight, and will not interfere with the laying of the cables. These coils consist of an iron core made of rings punched from sheet iron two one-thousandths of an inch in thickness, packed up to form a hollow cylinder of the proper length. This is wound with the conducting wire by threading it through the center as the figure shows.

Not only does Dr. Pupin's line serve for telephone transmission. There are systems of multiplex telegraphy that depend upon the transmission of electric waves. They work beautifully in the laboratory over short lines, giving a record on paper of dots and dashes at the rate of 300 words per minute for each instrument. But as soon as the line becomes of any length, the waves begin to lose their character,

the dots and dashes begin to run together, and finally form a continuous line. Tried on Dr. Pupin's artificial line without the coils, a few miles was sufficient to render the record illegible. But on introducing the coils, the dots and dashes became at once sharp and distinct, and several messages could be transmitted at the same time over the same line, by using different frequencies, and instruments each tuned to respond to one of these frequencies. What an enormous advantage this would be on an Atlantic cable! The maximum rate of transmission ever reached on an Atlantic cable, and that only as a test, was 40 words per minute. This multiplex transmission would carry this up to 1,500 words, or many times more than is now possible with all the cables working to their full capacity.

Such is the invention which scientific study and mathematical analysis has made possible. Most electrical engineers would have said that coils of wire, of all things, should be kept out of a telephone line. They are used in alternating current circuits to hold back the current. They are called "choke coils." They are often used to regulate the current flow. But every electrical engineer knows that while the coil does hold back the current, it does not, like a mere resistance, consume power. Such current as goes through it, goes with little loss of energy, and now that it has been pointed out, it is easy to understand that while a coil does hold back the current, it does not interfere with the transmission of energy over the line, but, by diminishing the current, diminishes in a greater ratio the loss on the line, and, above all, serves to preserve the characteristics of the electric waves and so delivers the energy to the receiver in the same form as when it came to the line.

## THE TELEPHONOGRAPH.<sup>a</sup>

By WILLIAM J. HAMMER.<sup>b</sup>

The telephonograph, or, as it is sometimes called, the "telegraphone," the "microphonograph," and the "magnetophonograph," is the invention of a Danish electrical engineer, Mr. Waldemar Poulsen, of Copenhagen, Denmark. This beautiful and ingenious instrument was considered by all those who had the opportunity of seeing and testing it at the recent Paris Exposition to be the most interesting scientific novelty there exhibited. In principle it is so simple it seems remarkable that with all our familiarity with electricity and magnetism such an invention should not have been made long ago. The apparatus, which is indicated in figure 1 (Pl. I), consists of a drum of brass about  $11\frac{1}{2}$  inches in length by  $5\frac{1}{2}$  inches in diameter. On this drum, which is revolved by means of an electric motor, is wound 225 turns of steel piano wire, of a diameter of about 1 mm. Supported above this wire, and in contact therewith, is a tiny magnet, such as are shown in figure 2, letters A and C, which are almost natural size. This magnet is attached to a brass support, mounted on a shaft, so that as the drum or cylinder carrying the steel wire revolves, the magnet is caused to move from right to left across the drum, being guided by a grooved finger resting upon the steel wire on the drum, each turn in the steel wire passing consecutively before the poles of the tiny magnet. On reaching the end of the cylinder,

---

<sup>a</sup>Washington, D. C., December 6, 1901.

MY DEAR SIR: I have been much interested in the Poulsen telegraphone, which I spoke of to you in Paris, and I do not know of anything in the work of recent years in electricity more worthy of being presented to the readers of the Smithsonian report. Mr. Hammer's article, which you show me, seems to be a very satisfactory popular exposition of it.

Very truly yours,

ALEXANDER GRAHAM BELL.

Mr. S. P. LANGLEY,

*Secretary of the Smithsonian Institution,*

*Washington, D. C.*

<sup>b</sup>Presented at the 151st meeting of the American Institute of Electrical Engineers, New York, February 28th, 1901. Reprinted, by permission, from Vol. XVIII of the Transactions of the Institute.

an arm mounted on the left side of the frame strikes the tiny lever shown in the illustration, raising the magnet, and causing it to run rapidly back to the beginning again (the carrier being guided by the coarse threaded shaft, shown parallel to the supporting shaft) this operation taking but five seconds. The legs of this magnet are about seven-sixteenth inch long, and are wound with bobbins of wire of about the same size as those employed on an ordinary receiving telephone magnet. A cross section of the magnet is shown in fig. 2, letter C. It has been found that a horseshoe form of magnet, as shown in fig. 2, letter B, will not respond rapidly enough, and it is preferable to employ two separate magnets electrically connected, as shown in fig. 2, letter C. In the ribbon form of telephonograph the horseshoe magnet shown in fig. 2, letter D, may be used, but even here two magnets electrically connected are preferable. This recording electro-magnet, which has a resistance of 100 ohms, is connected in circuit with an ordinary carbon telephone transmitter, and a couple of cells of battery, and preferably with an induction coil in the usual manner. When the transmitter is spoken into, it acts as a tap upon

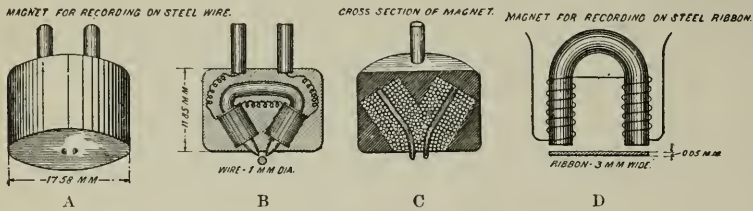

FIG. 2.—Telephonograph magnets.

the battery and causes currents of varying strength, and in proportion to the strength of the sound waves impinging upon the diaphragm, to pass through the wire wound on the electro-magnet. Now as the steel wire wound on the drum passes in front of and in contact with the poles of the magnet, its varying magnetic field magnetizes transversely the steel wire, and the "lines of force" are permanently recorded therein. After the steel spiral has been filled, which operation takes about thirty-nine seconds at an ordinary speed of talking, and records 100 to 120 words, the tiny magnet is placed at the point where the record first started, and in place of the transmitting telephone with which it was connected a Bell receiving telephone is attached. The cylinder or drum again revolves, and as the magnetized steel wire passes before the poles of the electro-magnet it forms a species of magneto-electric generator, giving out currents of electricity of a strength and direction corresponding to the magnetization of the steel wire, which correspondingly affect the Bell telephone, and reproduce the sounds and words originally spoken with absolute fidelity. In Edison's phonograph and its modifications, such as the graphophone, gramophone, etc., a stylus is always employed to indent the surface of



FIG. 1.—POULSEN'S STEEL WIRE TELEPHONOGRAPH.

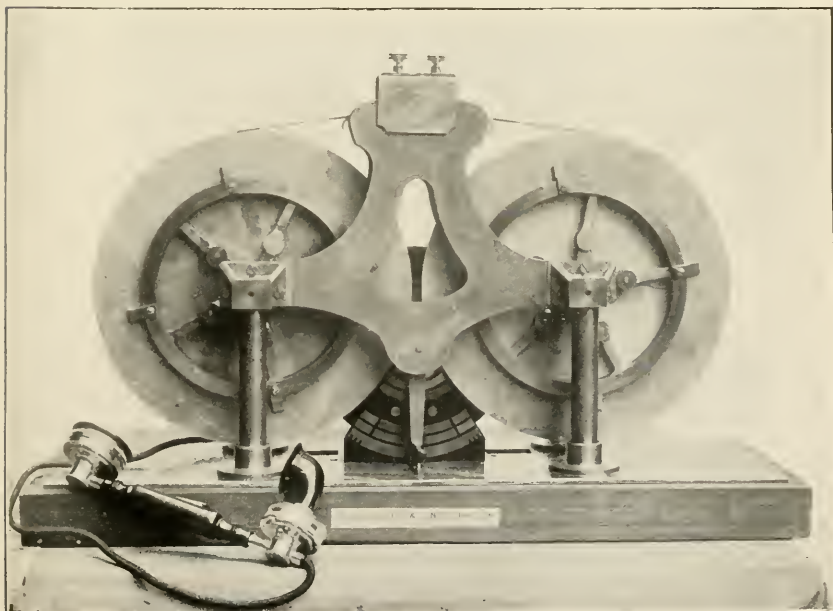

FIG. 3.—POULSEN'S BAND TELEPHONOGRAPH.



wax, metal, or other yielding substance. The stylus resting upon such a surface, and being attached as it is to the vibrating diaphragm of the phonograph transmitter, is affected by the dampening effect of the needle or its inertia, and the higher harmonics are more or less destroyed, and there are also false sounds produced, due to the molecular disturbances in the needle and diaphragm itself. Although Mr. Edison has recently made remarkable improvements in the perfection of recording and reproducing by means of his phonograph over his earlier forms, there are difficulties such as I have referred to which it has heretofore been impossible to overcome. In Poulsen's telephonograph, however, the tiny magnet not being in contact with the steel wire, the lines of force are silently stored up, and without being affected by external influences. The author has had considerable experience in working with various types of phonographs, and was accorded facilities to examine and operate the telephonograph both at Paris and Berlin, and still more recently here in New York. In Berlin, Messrs. Mix and Genest have for some time past been conducting a laboratory for experimental development of the telephonograph, and through their courtesy and that of Director Zopke I was afforded the pleasure of visiting this laboratory, and saw some very interesting developments in this promising field. I found the instrument would record and reproduce the most delicate sounds, even breathing and very low whispering, and certain words which those who have had experience in working with the phonograph know have always been very difficult to record and reproduce perfectly. All have been taken care of most perfectly by the telephonograph. If it is not desired to retain the record made upon the steel wire, the recording magnet is placed at the end of the drum and connected with a couple of cells of battery, which supply a constant magnetizing current to the magnet, which entirely obliterates the records which had been stored up in the steel wire, as this wire is passed before the poles of the magnet. A permanent magnet may also be employed for this purpose.

Another type of instrument which Mr. Poulsen has designed is shown in fig. 3 (Pl. I). This consists of two reels, carrying a band or ribbon of steel about three-sixteenths inch wide and about one-thirty-second inch thick. This steel ribbon, which may be made of any length and which may be recorded upon for an hour or more at a time, is passed from one reel to the other, the reels being operated by a small electric motor. Above the steel band or ribbon is placed a tiny electro-magnet of the form shown in fig. 2, letter D, which is connected to a telephone transmitter and battery, in the same manner as in the instrument already described, and after a record has been made, is also connected to a Bell telephone as a reproducing instrument. It is stated that these steel ribbons after receiving the magnetic record could be wound in many layers, similar to a spool or bobbin of ribbon, without affecting the record, and that the record could be reproduced thou-

sands of times. It is said that a record has been reproduced 2,200 times and has still been very perfect, and such a spool containing a record could be shipped across the country and placed on another machine, and would reproduce the sounds which originally caused the record with absolute perfection, and even a rusty wire containing a record has been sandpapered and polished without affecting appreciably the record. In fig. 5, letter D, is indicated, first, how the steel band is magnetized by the obliterating magnet, then by the varying field of the recording magnet, and finally by the reversal in direction. The Poulsen telephonograph in its ordinary form does not speak louder than an ordinary Bell telephone. I would suggest the employment of Edison's "electro-motograph" or "chalk" telephone receiver, by means of which it could be made to speak very loud. (An audience of 5,000 has been able to hear perfectly this Edison's loud-speaking telephone.) Mr. Poulsen has suggested a number of other methods by which the sound could be aug-

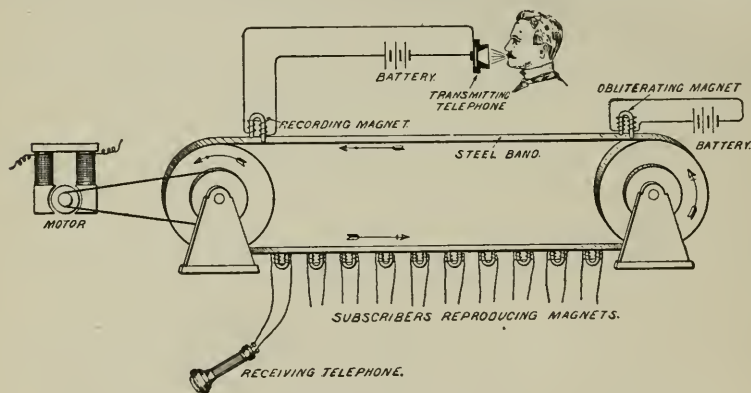

FIG. 4.—The talking newspaper.

mented. It is claimed that by increasing the speed during reproduction, over that of the recording speed, the telephone speaks much louder. This would, however, tend only to increase the pitch, and not improve the volume of the sound. Other methods suggested by Mr. Poulsen are indicated in fig. 5, letters A and C. They consist in substance of methods for causing one transmitter to make a number of records on separate steel wires or bands which, on repeating, cause the various reproducing magnets to simultaneously affect the one telephonic receiver. It has also been proposed to utilize the telephonograph as a talking newspaper. In fig. 4 is shown a method which it is proposed to employ. As the steel ribbon which, in this particular form is endless and which is receiving the record, passes from one reel to the other, as indicated by the arrows, it passes consecutively before each of the receiving magnets, which are shown in horseshoe form, but which may also be single pole, and the subscribers, whose telephones are attached to these magnets, are thus con-



stantly being supplied with the latest news of the day, stock quotations, etc. After the ribbon or band has passed before these magnets the obliterating magnet wipes out all of the magnetic lines of force stored up in the steel band, and it then passes on to receive fresh impressions from the recording magnet and telephone. In this connection I wish to say that in Budapest I recently found a talking newspaper system being run in connection with the supplying of music, and talking from the theatres by means of the "theatrophone." During the day the subscribers were constantly being informed of the latest news of importance. This service, which supplied many thousands of subscribers, was independent of the regular telephone service. I also remember equipping the Theatrophone Company in Paris in 1889 with two Edison phonographs for a like purpose—this being the first attempt in this direction. Many suggestions have recently been made for employing the telephonograph in telegraphic and telephonic work, just as were made many years ago when Edison invented his phonograph. It remains to be seen how important the practical applications of this wonderful scientific instrument will become, but it is self-evident that any invention possessing such intrinsic merit is certain sooner or later to meet with important commercial applications. The author, in common with many others, has used the phonograph in his office; dictating at his convenience his correspondence upon the cylinders, from which it was later transcribed by the typewriter. He was recently shown and operated a form of Poulsen's telephonograph, which had three magnets attached to the recording magnet carrier, which enabled him to start, stop, and reverse the movement of the carrier, and also obliterate errors in the wire. In fig. 5, letters B and E, are shown two methods proposed for duplexing. The two sets of magnets are shown connected, in the one case, in parallel; and in the other, in series. These magnets may all be connected in series or all in multiple, but it is essential that they should be with the proper polar relation. It is claimed that these two sets of recording magnets send waves of a different character over the line, and at the receiving end of the circuit each reproducing magnet will respond to its proper wave. I believe the form shown in fig. 5, letter E, has never been demonstrated to be practicable, but the one employing the two ribbons shown in fig. 5, letter B, has been operated successfully. Suggestions have been made for using the telephonograph as a telephonic relay, and I am informed that some experiments have been made recently in this direction in Europe, and it may perhaps not be out of place, in this connection, to call attention to the experiments made by the author in employing the phonograph as a telephonic relay at the time of his lecture on Edison and His Inventions, delivered before the Franklin Institute on February 4, 1889, which experiments were described in the *Electrical World* of February 16, 1889, and other

papers, and subsequently more fully described in the *Electrical World and Engineer*, of June 3, 1899. The diagram shown in fig. 6 (Pl. II) illustrates very clearly the arrangement of the two phonographs, four telephones, two sets of induction coils and batteries and other apparatus, circuits, etc., and these experiments constitute, I believe, the

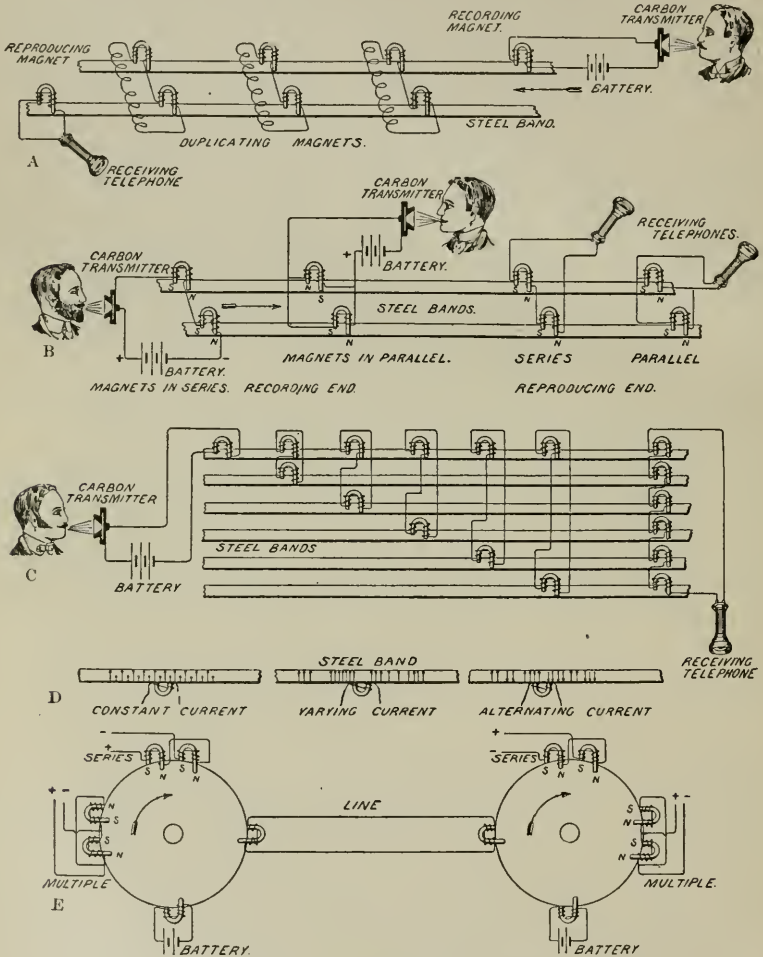

FIG. 5.—Proposed methods for increasing volume of sound and of duplexing.

first practical form of telephonic relay which has ever been constructed, and which operated with perfect success over 104 miles on the lines of the Long Distance Telephone Company, between New York and Philadelphia. (It is interesting to note that the sound passed through the air five times, through fifteen separate mediums, and changed its physical characteristics 48 times in transmission.)<sup>a</sup>

<sup>a</sup> See *Electrical World and Engineer* of June 3, 1899.





## COLOR PHOTOGRAPHY.<sup>a</sup>

By Sir WILLIAM J. HERSCHEL.

The attempt to reproduce the natural colors of objects in a picture of them by means of photography may be regarded, according to a man's fancy, either as a confession of weakness—of lack of artistic power in oneself—or as a laudable ambition to invoke the powers of nature to do what, with all human skill, no artist can ever expect to do or ever claims to do. The artist, whether of the pencil or of the palette, has a liberty of expression which must forever make him master of the spirits of men when they seek the aid of painting or drawing to represent any scene to their senses. He alone understands the spirit that seeks his aid. He alone knows how to minister to it in the way that will most delight and instruct it. God has given him a great wealth of materials and the incomparable gift of genius in his use of them to interpret a scene to his fellow-man. If he fails, as he often does, in his task, that is no more than human frailty involves. When he succeeds he has given us a joy which we never dream of attaining in any other way short of once more beholding the object of our desires as we saw it in some happy moment of our lives. I am speaking, of course, only of realities and not of poetical or ideal art.

No one can be more conscious of the vast interval that lies between himself and the true artist than the humble follower of nature along the paths of color photography. To describe his position as a student fully and justly would occupy more time than you can spare me; but of this I am confident, that no artist can have his feelings more keenly cultivated, his appreciation of the delicacies of hue and of shading more exalted, or his ambition to equal nature more excited by the first fruits of his labors than the patient, watchful handler of the camera and its adjuncts. The artist, indeed, stands at a strange disadvantage here. No joy can ever reach him which he has not, in the richness of his imagination, already tasted before he meets it face to face on his canvas. But who that has hung in eager expectation over the growing wonders of the sensitive plate would exchange his happiness when

<sup>a</sup> Presidential address by Sir William J. Herschel, Bart., to the sixteenth annual meeting of the photographic convention of the United Kingdom, Oxford, July 8, 1901. Reprinted from the *British Journal of Photography*, July 12, 1901, pp. 439-441.

success rewards him for that of the artist over his own handiwork; surprise, gratitude, exhilaration, these are the sudden moods of the photographer who throws himself into the arms of nature and trusts to her methods while incessantly pleading for more and more of her instruction. What shall I say of his many, many disappointments? Let them pass. We know their value, and the artist knows this, too. Our joys and his are not the same, but both are ripples of that *ἀρηριθμον γελασμα*, the countless laughter of the ocean on which God's great gift of light dances and entrances us.

So it is in the most perfect humility of spirit that we approach the subject of our discourse this evening—the practical methods now known to us of producing colored photographs.

These fall into two groups. In the first, as now in our common possession and practice, come those which employ colored glasses or films to feed the photographic plate, leaving the latter to take what it will, or refuse what it will, according to the high commands impressed upon it by the sun. Let no one be under the delusion that here is any room for the color artist, man, to tamper with the result, to distribute the colors according to his fancy. The very contrary is the case. No department of photography is so hopelessly bound to perfect honesty and freedom from trickery as color photography. A first-year apprentice in the studio of Mr. Herkomer would as soon think of improving the master's touches. It would mean ruin to the picture. Whatever color is supplied is fairly offered to the sun at every pin's head of the plate alike; but whether it is to be seen at all, and if seen whether it is to be seen in its full strength or weakened to any necessary extent, is not in our hands. That rests with the light itself to determine which falls there on the sensitive surface, and woe to the man who tries to interfere there. He may use some influence in regard to considerable areas at a time, just as the ordinary photographer can shade or modify the light to produce general effects, but as to details he dare not say a word. He might as well try to improve a miniature with a house painter's brush.

The first specimens of this kind which I introduce are those of Mr. Ives's process.

The three photographic positives here thrown on the screen together as one picture are plain black and white. They each act in the same way that the natural object did—they do not, indeed, absorb the color of the covering glass; but they do what comes to the same thing, they block it out either totally or in various degrees as each point of the object did by absorption. The positive was obtained by photographing the object through a glass of somewhat similar color. That it is not the very same color is due to the fact that the photographic power of colored light is not on all fours with its coloring power upon the retina.











A HOEN & CO. LITHO CAUSTIC, BALTIMORE.

FROM A COMPOSITE HELIO-CHROME

BY MR. IVES

To go into anything like detail on this complex and still debated part of the science of color photography would be quite impossible—and I am glad for your sakes that it is so, for only a strong expert like Mr. Ives or Mr. Sanger Shepherd could lead you aright there. Suffice it to say that at this point the judgment of the human eye is the final court of appeal, and no conclusions based upon anything less than large practical experience can be deemed final. We are still in the purely empiric stage of knowledge as to the physical connection between the color and the actinic power of any given light. We are not even sure that a given color of a given intensity has a constant actinic power on a given film. What we see here is the result of Mr. Ives's immense practical study.

His Kromskop introduces the three colors to the eye, not by superposition, which, as you will readily see, would put three extinguishers on the top of each other, but still by true *com*-position. The mirrors (sheets of transparent glass) which do this are models of inventive power. They are not clear glass, but tinted, and the reason for this is a matter of refined delicacy. The already green image passes through a transparent green glass, placed on a slope which thus serves on its front face as a mirror for the blue image. The latter would be reflected from the back surface also if the glass were clear white; but being green, it absorbs the second reflection sufficiently (in the double passage of the blue light) to make it innocuous. The composite blue-green image passes on to the eye through another sloping transparent mirror placed to reflect the red image in the same line of sight. The same danger of a double red image is avoided here by tinting the mirror blue-green, which lets the blue-green image pass, but kills the red light which endeavors to get twice through it. The perfection of the register is thus preserved.

Of a cognate character, but very different in its method, is Mr. Sanger Shepherd's process, in which three differently colored films are *superposed* one on the other in a single transparency. They are all positives without any opaque silver deposit to block out light. The only gradation is from clear white to the deepest color of the dye on each film—superposed they act as absorbents, and so effect the same fallibly, as far as I am aware; but, assuming it to be true, see what it means; nothing less than this, that we have, by the infinite delicacy of photography, obtained a definite ocular demonstration of the precise seat of power which ether waves have over chemical compounds. If I hesitate in committing my own belief to this explanation (and my belief is a matter of absolutely no importance to anyone else) it is because it is not inconceivable that the disruptive action which does take place may, after all, occur close round the spot where the stationary ether of the node, and therefore the matter which is affected, is under alternate tension and relaxation. However that may be in physics,

the difference is not of immediate importance to us in photography that I see. The actinic planes were proved by Wiener to exist. Lippmann turned them to vital account for us, and gave us, in the way we all know, true color photography. He used thick films for the express purpose of securing what Wiener desired to avoid, reduplication of the actinic planes, and with them the strong creation of color. Here are some of the most exquisite results of his process. I owe them to Dr. Neuhauss, who kindly supplied me with a spectrum and a vivid picture from what I may call still life, and to Mr. Senior, who has placed his best specimens of a spectrum with the Fraunhofer lines at my disposal for your service. A more precious one than any of these is this given me by Dr. Lippmann himself, a tribute to my father's memory as a pioneer of photography, which I shall be happy to show afterwards. It is the simple naked film itself.

Before parting with Lippmann's process I feel sure that you will like to see the decisive evidence obtained by Dr. Neuhauss of the presence in the film of the supposed strata of silver spangles, as I may call what looks like a brown stain more than anything else, by transmitted light. He has actually made a microscopic section of the color cradle, and by means of the most refined conditions has been able to take once more by aid of photography a visible picture of the subtle work of light in the interior of a Lippmann film. Here is a copy of it on the screen which he has sent me himself, with his explanation of its import and its manufacture. All room for doubt (if science could cease from doubting its own creeds) would seem removed by this simple fibrous-looking strip of lines. It is a rare pleasure to be able to exhibit such brilliant colors, and such surprising demonstrations of their cause, here in Oxford, and to acknowledge at the same time that the whole series of investigation and invention which have furnished these magnificent results is the fruit of French and German industry and genius.



A. SPEN & CO. LITHOGRAPHERS, BALTIMORE

FROM A COLOR PHOTOGRAPH BY THE MCDONOUGH PROCESS



# THE HISTORY OF CHRONOPHOTOGRAPHY.<sup>a</sup>

By Dr. J. MAREY,  
*Member of the Institute of France.*

By chronophotography<sup>b</sup> is meant a method which analyzes motions by means of a series of instantaneous photographs taken at very short and equal intervals of time. By thus representing, for example, the successive attitudes and positions of an animal, this art renders it possible to follow all the phases of the creature's gait, and even to construct exact drawings of it to scale. Of late years, chronophotography has taken another direction—that of the synthesis of motion. The analytic images are made to appear before the spectators' eyes in uniform sequence, so as to reproduce the appearance of the motion itself. Everybody is familiar with such animated views.

The International Exhibition of 1900 enabled us to bring together the documents relating to the invention and successive improvements of chronophotography.

## PART I.

### DESCRIPTION OF THE APPARATUS.

The principal instruments which, in the course of the development of chronophotography, have been devised by those who have pursued this art were collected in a large show case (fig. 1).<sup>c</sup> They were arranged according to the dates of their several inventions. In addition four large frames contained photographs resulting from the application of chronophotography to various branches of science.

*No. 1* is Janssen's astronomical revolver, invented by that astronomer in 1873 in order to show successive positions of the planet Venus near the limb of the sun at her transits.

At the focus of a telescope pointed at the sun was a photographic camera, and the sensitive plate, which was circular, turned about its center by leaps, so as to bring into the field a different portion of its

<sup>a</sup> Translation from "Exposition d'instruments et d'images relatifs à l'Histoire de la Chronophotographie, par le Docteur Marey, Membre de l'Institut," printed in pamphlet entitled Musée Centennal de la Classe 12 (Photographie) à l'Exposition Universelle Internationale de 1900 à Paris—Métrophotographie and Chronophotographie.

<sup>b</sup> Photochronography was the form of the word originally employed by the writer, but it has been modified in conformity to a decision of the Congress.

<sup>c</sup> The exhibits were arranged in chronological order and numbered, but the illustration (fig. 1) in Dr. Marey's article was on too small a scale to show details and is here omitted.

border at the end of every 70 seconds of time. In that way a series of images were obtained (fig. 2) which showed the successive positions of the planet on the sun. She was seen to penetrate the limb, to cross the disk, and finally to depart; and the interval between the images being known, the velocity of the movement could be measured. This experiment seems to have been the earliest achievement of a chronophotograph; for though others before Janssen conceived bolder

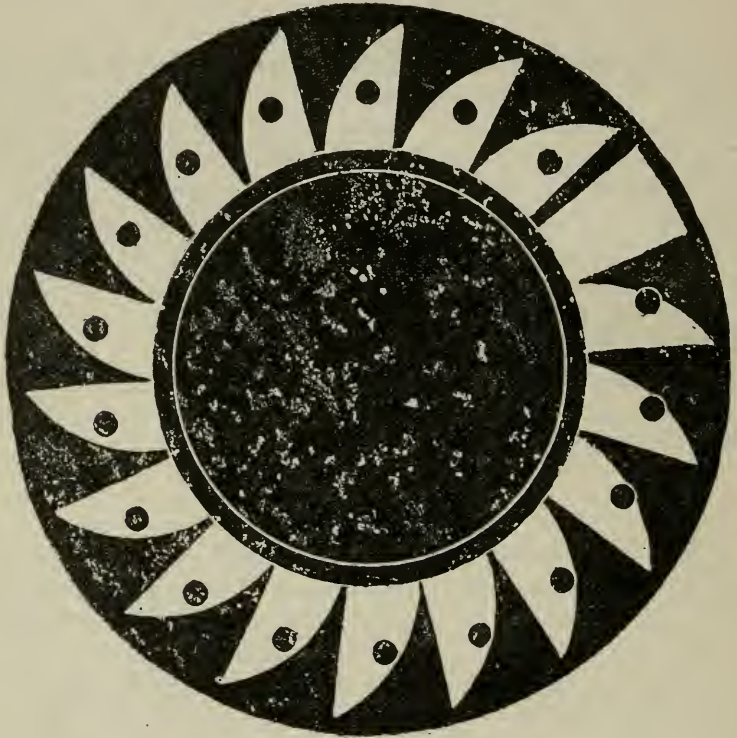

FIG. 2.

attempts, there was, in an exhibition of real things, no place to show plans or projects impracticable at the time of their invention.<sup>a</sup>

*No. 2. Analysis of the motions of animals by the method of Muybridge, 1878.*—This celebrated photographer of San Francisco suc-

<sup>a</sup> In an article on the "Beginnings of the Cinematograph" in *Camera Obscura* for February, 1901, Mr. Charles Niewenglowski refers to an ingenious idea of 1857 of Charles Adolphe Reville of bringing into a stereoscope a succession of double photographs of the phases of a phenomenon. But for that purpose it would have been necessary to take the photographs of the objects in motion, which at that date would have been impossible, except at the lowest velocities. The same article figures an apparatus devised in America about 1861 by Coleman Sellers. It was called a "stereophantascope," and was intended to obtain the same result as Reville. The most remarkable conception was, by all odds, that of M. Ducos du Hauron, who in March, 1864, took out a patent for an apparatus for photographing any scene with all the transformations which it might go through in a given time. How to take the photo-



ceeded in fixing in successive instantaneous photographs all the phases of the gaits of a horse, even at the swiftest gallop. He studied by the same method the motions of man, as well as the principal types of quadruped locomotion.

His arrangement was as follows: Multiple cameras, numbering from 12 to 24, according to circumstances, were arranged in series and pointed on a track where a horse was galloping. Each camera had a quick-acting shutter worked by an electro-magnet. In passing along the track the horse successively broke a series of wires, each of which in breaking set free the shutter of one of the cameras. Things were so arranged that, as he passed along, the animal caused the successive production of a series of instantaneous photographs (fig. 3).<sup>a</sup>

Muybridge's method was, shortly after, used by Anschütz, of Lissa, who seems to have made some improvements in it. In particular he

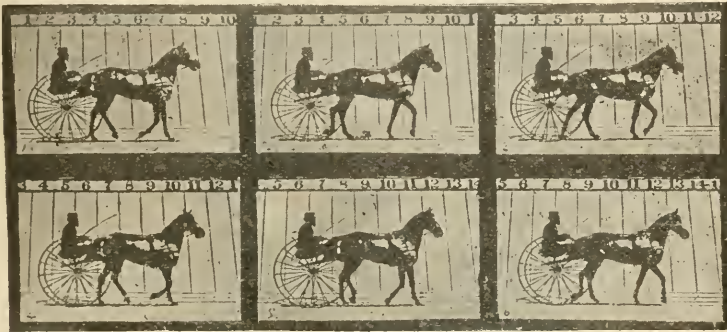

FIG. 3.

was favored by fortune in being able to use the newly discovered plates of gelatino-bromide of silver. Some fine series of photographs by Anschütz were shown in the glass case.

*No. 3. Chronophotography on a plate fixed before a camera obscura, Marey, 1882.*—The analysis of motion by chronophotography was already worthy of attention in 1882. The apparatus was, however, too costly, while the measures of distances and times were defective, when the writer endeavored at once to simplify the experiments, and

graphs and how to project them in animated form is thoroughly explained and figured in the patent of M. Ducos du Hauron; but the idea was entirely impracticable at the time.

It may be added, in all these apparatus the perception of movement is due to the persistence of retinal impressions, which was the principle of Plateau's phenakistiscope of 1833.

<sup>a</sup> We place the experiments of Muybridge along with those of chronophotography, although this ingenious experimenter did not succeed in taking his instantaneous photographs at equal intervals of time. For the velocity of the horse not being quite uniform, the equidistant wires were not reached at equal intervals of time. Besides, the wire was more or less stretched before rupture took place. From these causes there was a certain inequality in the rates of succession which Muybridge did not succeed in satisfactorily overcoming by letting off the shutters independently of the horse's motion.

at the same time to give them precision. The principle of the first method employed was as follows:

Suppose an ordinary camera to be pointed at a perfectly dark field, and that an opaque disk in front of the lens is pierced with narrow openings and turns about its center. Every time an opening passes before the objective the light would be admitted, if there were any light in the field. But there being no light, none penetrates the camera; and when the plate is developed it is seen not to have been affected. If a strongly lighted man or animal were to cross the dark field, each admission of light would produce an image of the animal, and as the latter moved, photographs of it would be taken on the plate at different places and in different attitudes. Such an arrangement, however, would not answer. Fig. 4 shows the apparatus in its real form. Within a cubical box is seen the camera with its lens. Behind it is the plate holder or back, C, which slides in grooves. Between

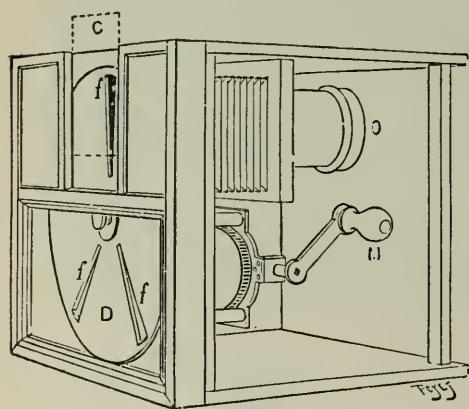

FIG. 4.

the plate holder and the camera revolves the slitted disk grazing the sensitive plate—in short, what is called a plate-shutter. This disk, D, with its narrow openings, f, is worked by a clock movement furnished with a speed governor, and is set in motion by a handle. Fig. 5 (Pl. I) shows the flight of a white duck, which passes before the dead black background. The succession of images is from left to right.

Eight different attitudes are shown during one complete stroke of the wings. They reveal the details of the mechanism of flight. In order to appreciate the dimensions of the animal and the extent of its flight, a divided rule is placed before the dark field. It is photographed and serves as a scale. Finally, in order to show the intervals of time between the successive images, at the lower right-hand corner of the dark field is placed a chronograph, consisting of a dial, which has a white hand completing an entire revolution in a second. Every time the shutter disk admits light and causes a photograph of the bird this hand is likewise photographed. Since it is seen to occupy eight successive equidistant positions on the dial, it is evident that the intervals have all been one-eighth of a second.

*No. 4. Dark field for chronophotography on a fixed plate.*—No body is quite black. Chevreul showed that absolute blackness can only be procured by means of a hole into a cavity with blackened walls, upon which no light is allowed to shine. [That is, there should be another



FIG. 5.—CHRONOPHOTOGRAPH OF A WHITE DUCK IN FLIGHT.



black hole facing the first.] In order to approximate to these ideal conditions, the writer constructed a deep shed tapestried with black velvet and facing so that no light penetrated it. In that way very sharp images are obtained upon an unclouded background.

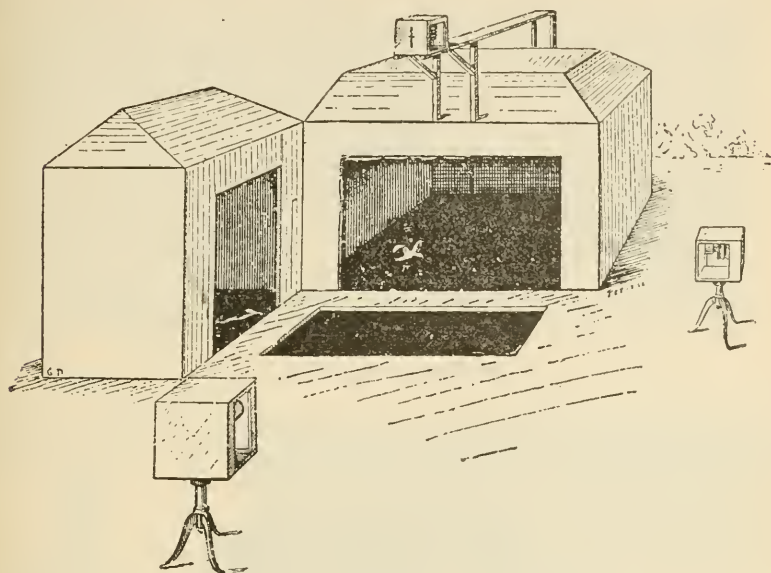

FIG. 6.

*No. 5. Figures in relief obtained by the use of chronophotography.*—A single apparatus only gives the projection of the motions on a plane perpendicular to the optical axis of the instrument. But if three chronophotograph cameras are focused on dark fields or dead-black

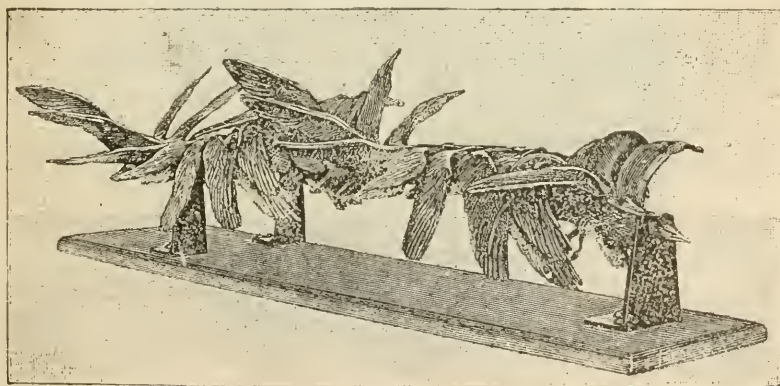

FIG. 7.

backgrounds perpendicularly to one another (fig. 6), the animal represented will be seen from three different points of view, which will enable us to understand its real attitudes by reference to the three dimensions of space. Fig. 7 shows a series of bronze figures, united

each to the next, and representing the successive attitudes of a sea-gull in flight.

*No. 6. Photographic gun, 1882.*—In the study of the flight of birds the necessity of operating before a dark field or dead-black back-

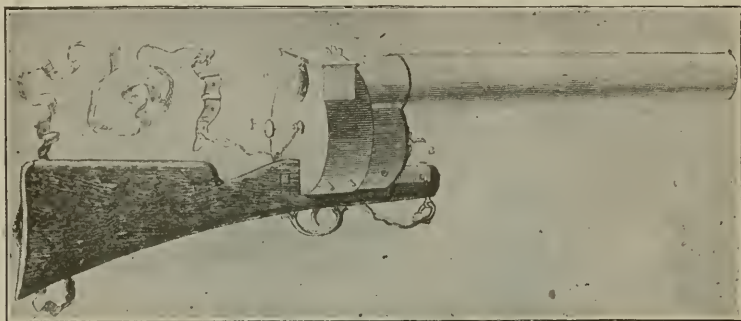

FIG. 8.

ground restricts extremely the number of possible experiments. In order to analyze free flight it was requisite to be able to operate in case of need on the bright sky and to arrange an apparatus capable of being

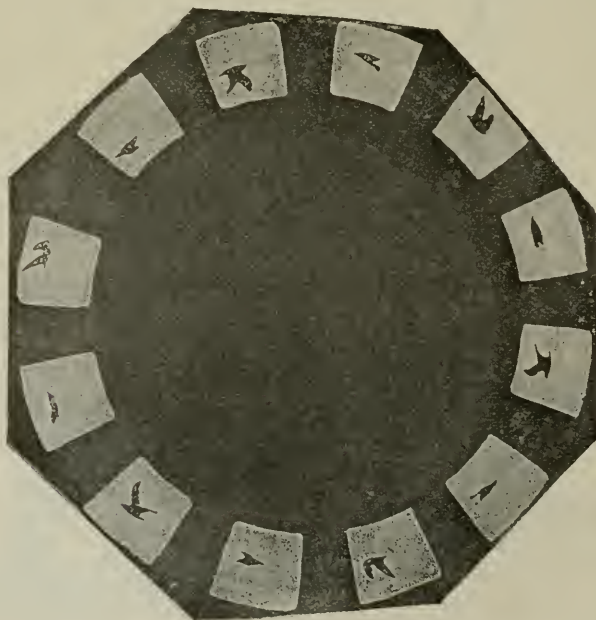

FIG. 9.

aimed at a moving bird like a gun. The photographic gun (fig. 8) contains in its barrel a long-focus objective. In its breech there turns a circular plate, which presents to the focus of the objective different points of its border. In short the apparatus is analogous to the astro-

nomical revolver of Janssen, with this difference, that it produces pictures about 800 times more frequently, which calls for a pretty delicate mechanism. Fig. 9 shows the photograph of a gull in free flight.

*No. 7. M. Londe's apparatus with multiple objectives, 1883.*—Returning to the method of Muybridge, with a very important improvement, M. Londe, aided by M. Dessoudeix, constructed an apparatus in which a series of twelve objectives form their images upon different parts of a rectangular plate of large size. An ingenious arrangement causes the successive opening of these objectives at equal intervals as short as may be desired. The analysis of the motion is consequently very perfect. The order of the images can not be deranged, since they are all obtained on one plate. But the number of pictures is limited by the necessity of having a separate objective for each. General Sébert by a similar method analyzes the phases of the motion of torpedoes.

*No. 8. Multiplication of the number of pictures: 1. Partial photographs. 2. Dissociation of the images before the dark field. 3. Photographs on a film ribbon in motion, 1887-88.*—A perfect analysis of



FIG. 10.

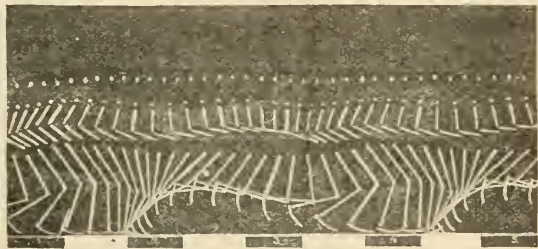

FIG. 11:

motion requires that the photographs be taken at as short intervals as may be, yet for as long a time as possible. If we merely make the rotation of the shutter-disk faster, the number of images will, it is true, be augmented, but the animal's locomotion not being thereby accelerated, the result will be that the photographs will be taken so close together that they interfere with one another and produce the confused effect seen in figure 7. A first way of avoiding this confusion is to photograph, not the entire body of the subject, but only certain points or lines whose position is significant of the facts we desire to know. A man dressed completely in black (fig. 10), and consequently invisible upon the dead-black background, wears certain bright points and lines, strips of silver lace attached to his clothes along the axes of his limbs. When this man, so rigged, passes in front of the apparatus, photographs will result that will be accurate diagrams to scale (fig. 11), showing without confusion the postures of upper and lower arms, thighs, lower legs, and feet at each instant, as well as the oscillations of the head and of the hips. The method also allows the play of the joints to be studied.

Still, it was desirable to multiply the images while showing the whole body. For that purpose the insufficiency of the advance of the subject has to be made up for by a displacement of the image on the plate. This can be brought about in several ways. In the first place, the camera, with its attachments, can be pivoted on its support and caused to turn about a vertical axis. The difficulty of moving the considerable mass uniformly caused, however, the abandonment of this method in favor of the rotation of a mirror by clockwork, causing the reflection to strike different points of the plate. In this way a series of complete photographs are obtained, following one another at extremely short intervals of time. Indeed, the frequency of the photographs may be made very great. Their total number is, however, restricted because the optical axis of the instrument, being dis-

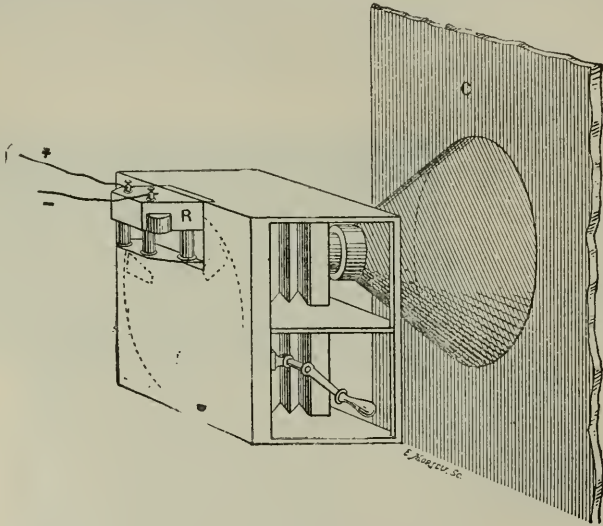

FIG. 12.

placed along the black background, soon reaches the end of it. A final solution was to take the photographs upon different points of a long fillet which moves along the focal plane of the camera and is stopped long enough for each exposure.

*Chronophotography on a film ribbon, Marey, 1887:* In consequence of the invention of the kodak, long paper fillets of gelatino-bromide of silver had become articles of commerce. A little later transparent films made their appearance; and these were still more appropriate for the chronophotography of long series of pictures. Three patterns of apparatus were exhibited in the case under No. 8. These showed the successive steps of invention.

Type a: The apparatus (fig. 12) worked in the red light of the dark room. The objective was pointed outward across a conical shade. In the place of the ordinary plate-holder was placed a shelf carrying a



clockwork R, which led a long paper ribbon over rollers. The rotation of the disk made an electric contact at each passage of a slit, in consequence of which an electro-magnet squeezed the band and stopped it long enough for the exposure.

Type b: It was necessary to avoid the extreme inconvenience of only being able to photograph within the dark room. A small portable box, B, was therefore made for the fillet, which, having been filled in the dark room, could be carried out with the rest of the chronophotographic apparatus, as shown in fig. 13. The results were more satisfactory.

Type c: Ultimately the application of electricity was given up, and the motion and stoppages of the film, instead of being governed by an independent clockwork, were connected with the movements of the disk.

*No. 9. Double-action chronophotography.*—With a view of obtaining an apparatus which should, at pleasure, either work upon a fixed plate or upon a moving film, an instrument was constructed represented by No. 9 in the glass case. This apparatus (fig. 14) is composed of a fore part, which slides in grooves. This fore part carries the objective and is cut so as to allow the shutter-disk to pass. The movement of the latter is governed by a rod of variable

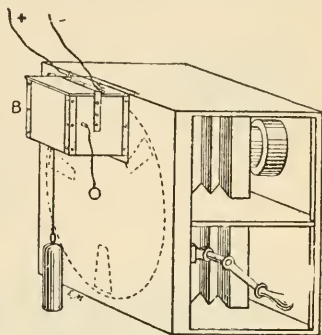

FIG. 13.

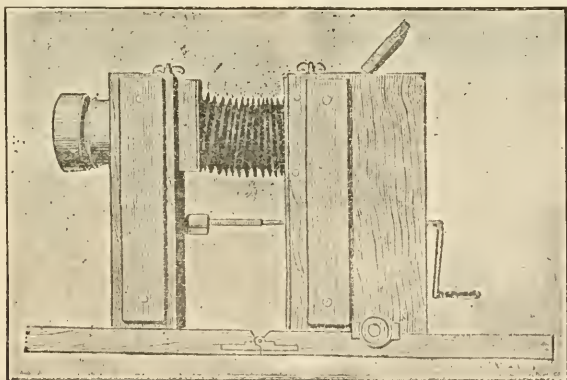

FIG. 14.

length (so as to permit focusing) connecting with clockwork within the after part of the apparatus. In this after part can be placed an ordinary plate holder for chronophotography on a fixed plate; or, if desired, the plate holder being removed, movable films may be introduced. These go into a back chamber, the open lid of which is shown in the figure. The film ribbons could be inserted in daylight in consequence of their being prolonged at both ends by ribbons of opaque

paper (fig. 15). When the whole was wound up round its spool before being put in, the film was protected from light by outer layers of opaque paper; and when the work was done and the film was wound upon the other spool it was equally protected by the other terminal of opaque paper so that it could be removed from the apparatus in the light without becoming clouded.

This apparatus, which was easily used, sufficed for three years for the writer's researches into the motions of man and of animals. Like

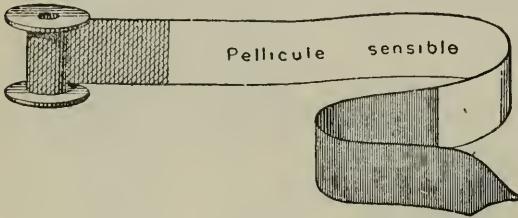

FIG. 15.

Muybridge, Anschütz, and Demeny, he aimed to obtain, by Plateau's method, the reproduction of the analyzed motions. At the exhibition of 1889, a zootrope moved by electricity showed animals in motion, as well as men,

birds, horses at different gaits. But since the zootrope does not allow many figures to be shown, the writer was restricted to exhibiting short movements. He therefore cast about for methods of showing scenes of long duration.

*No. 10. Chronophotographic projector, 1893.*—This apparatus carries an endless belt of photographs to the focus of an objective which projects them upon a screen. Fig. 16 shows the path of the rays in the projector. A pencil of parallel rays, reflected by a heliostat comes

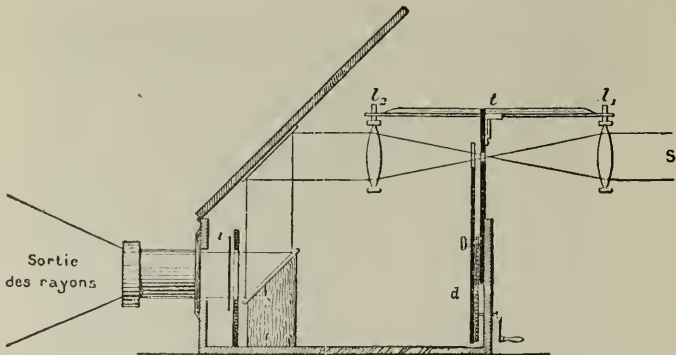

FIG. 16.

from *S*, and falls upon a convex lens  $l_1$ . This pencil brought to a focus, passes at  $t$  through a hole in a diaphragm, meets the shutter-disk  $d$ , which is turned by a crank, passes through every window that comes, then diverges and, meeting the lens  $l_2$ , similar to the first, regains its parallelism, is reflected at  $45^\circ$  from a mirror forming the lid of the box, falls vertically upon another mirror at the same inclination, and now passes to the objective. But in this last part of its course it

traverses the film, *i*, which carries the positive photographs, and these photographs, magnified by the objective, are thrown upon the screen.

The motion of the film at its halts at each flash are brought about by an apparatus not shown in the figure. It is similar to that of the simple chronophotographic apparatus, with the difference that the positive film, having its ends fastened together to make an endless belt, passes over a series of rollers which stretch it taut. The principal imperfection of the chronophotographic projector was a jerkiness due to imperfect equality of the intervals.

*No. 11. Edison's kinoscope, 1894.*—Mr. Edison found a means of equalizing the intervals. It was to perforate the sensitive film by a

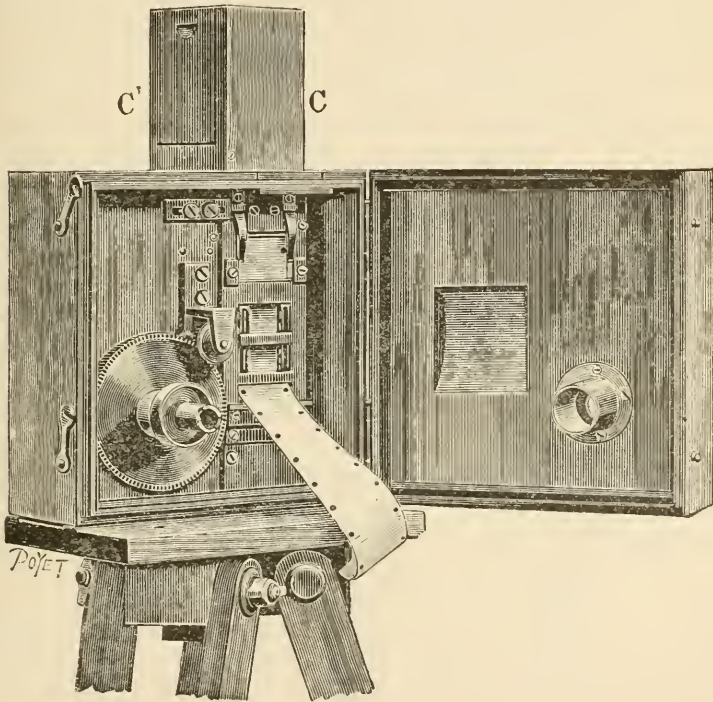

FIG. 17.

series of equidistant holes and gear it to a pin cylinder. It was impossible to procure a kinoscope to exhibit in the glass case; but everybody, of late years, has seen this remarkable instrument in action. It shows living scenes acted out for more than a minute with absolute precision. In Edison's apparatus the film-ribbon never was arrested; but the images were rendered sharp by the extreme brevity of the illumination, which was only  $\frac{1}{7000}$  of a second. A single spectator, looking through eyepieces, could see the living pictures of the kinoscope.

*No. 12. Lumière's cinematograph, 1895.*—This instrument finally gave the desired result—that is to say, the projection on a screen of

living scenes visible to an assembly and presenting a perfect illusion. The success of this invention was immense, and has not passed away. Fig. 17 shows the cinematograph open and arranged for taking photographs. A film, perforated like that of Edison, is rolled up in a closed box *c'c* on the top of the apparatus. It passes, in an intermittent manner, to the focus of the objective, being drawn forward by a system of claws which catch in the holes of the film. The reciprocating motion of these claws gives intermittency to the motion of the ribbon. After exposure the film is received in another closed box, invisible in the figure. It was important to make the claws acquire and lose their velocity as gradually as possible, so as not to tear the film. The Messrs. Lumière succeeded in effecting this by means of a triangular cam, fig. 18, which is the essential part of the apparatus. During two-thirds of the whole time the film is at rest.

For the projection of the positives, the Messrs. Lumière make use of a special arrangement. A powerful electric lamp brilliantly illuminates the film. In this way very bright projections are obtained of 25 by 19 feet (7.75 m. by 5.80 m.), the figures on the film measuring only 1 by  $\frac{1}{8}$  inches (25 by 22 mm.). In the glass case by the side of the cinematograph several ribbons printed on paper showed the perfection and happy choice of the photographs obtained with this instrument.

The success of the cinematograph gave birth to many forms of apparatus for the projection of living pictures. Most of them differ very little from the instrument of Messrs. Lumière, and were not shown. Two types, however, of marked originality merit special mention.

*No. 14. Captain Gossart's apparatus with oscillating objective, 1897.*—This instrument gives photographs of very large dimensions. Its author has applied it to the study of the gaits of the horse. Fine specimens of its work were exhibited.

It is not adapted to projections.

*No. 15. The Alethorama of Messrs. Chéri-Rousseau and Mortier, 1897.*—This is a projecting apparatus in which the perforated film-ribbons, as they pass along, give reflections of their pictures from a series of prisms. The projections are exceedingly bright and steady, and altogether make a fine effect. The apparatus, however, seems to be hard to adjust, and does not appear to have been taken up practically.

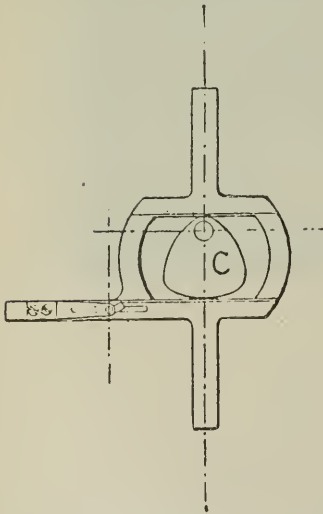

FIG. 18.



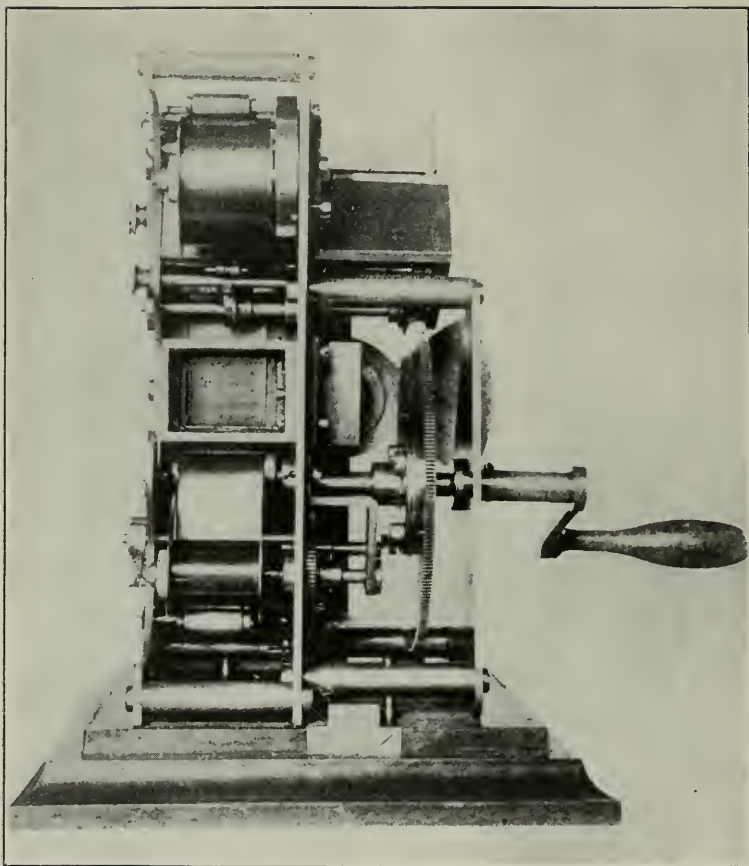

FIG. 19.—MAREY'S CHRONOPHOTOGRAPHIC APPARATUS.

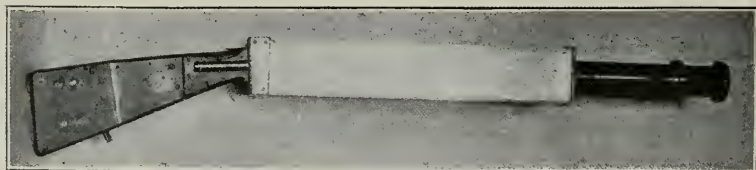

FIG. 20.—CHRONOPHOTOGRAPHIC GUN.

*No. 16. Analyzing and projecting chronophotograph, Marey, 1898.*—The writer has pushed the improvement of his chronophotographic apparatus, so as to obtain perfect equidistance of the views, and has succeeded in doing so while preserving the main principle of not perforating the films. For perforation, besides wearing, so as no longer to bring the pictures around regularly, also occupies a zone of  $\frac{1}{16}$  of an inch (2.5 mm.) on each edge of the ribbon, a loss which is more important the narrower the film. The writer has succeeded in obtaining perfect regularity in exposures by modifying the first pair of rollers which takes the film. The apparatus is shown in fig. 19 (Pl. II).

In making projections, a further difficulty arose, namely, the positive film undergoes some shrinkage in the successive developments requisite to obtaining it, in consequence of which the pictures, being too near together, pass by too soon, and tend to leave the field of the screen. A simple drag or brake upon the magazine spool corrects this fault. Positive ribbons of different breadths were exhibited, showing the sharpness and equidistance of the photographs.

*No. 17. Microscopic chronophotography, 1899.*—The writer has adapted the chronophotograph to the study of motions which take place in the field of the microscope. In order to avoid exposing the animals studied to the heat of an intense illumination, an arrangement was adopted in which the shutter-disk only effects the lighting up of the preparation during the time of exposure, which is about one-five-hundredth part of a second. This done, the brightest light no longer produced any injurious effects. Numerous photographs were exhibited, together with the instrument.

*No. 18. Chronophotographic gun with a film ribbon, 1899.*—In its original form the photographic gun only gave twelve views. For a more extended series an instrument of a new type (fig. 20, Pl. II) was constructed, in which the successive photographs are taken on a band 66 feet (20 m.) long. The shutter is formed of a light-cock, which is far less cumbrous than a disk. In the stock of the gun is a clockwork moved by a dynamo. Whenever the trigger is pulled the circuit is closed and the film begins moving, and does not stop until the trigger is let go. Light accumulators, or a portable pile, furnish the necessary current.

## PART II.

### SCIENTIFIC APPLICATIONS OF CHRONOPHOTOGRAPHY.

Animated projections, interesting as they are, are of little advantage to science, for they only show what we see better with our own eyes. At best, they serve to slow a motion which is too quick for direct observation, or to accelerate it if its extreme slowness causes us to miss some of its features.

In the former case photographs are taken at the rate of 40 or 50 to the second and are projected in three or four times the original time. We can thus show a horse galloping or a bird flying so slowly that the eye can follow the motions of the limbs. In the other case the photographs are taken at very long intervals and are projected in rapid succession. For this purpose the writer's chronophotograph (fig. 19, Pl. II) is furnished with an arbor upon which, if the crank is fitted, the effect is that only one photograph is taken at each turn. The slowest, almost imperceptible motions of clouds, taken at long intervals and rapidly projected, are translated into a rapid and striking agitation.

What is generally important in the study of a motion is to obtain a geometrical drawing of it. Chronophotography upon a fixed plate gives such a drawing to scale exactly. Chronophotography on a movable film may do so by the aid of certain devices which will be described below. Chronophotography on a fixed plate has furnished the experimental solution of many problems of geometry, mechanics, physics, and physiology that no other method could so readily have solved.

GEOMETRY. *Formation in space of geometrical figures of three dimensions.*—Geometers define this sort of figures by saying that they are generated by straight lines or curves of different forms displaced in different ways. Chronophotography realizes this conception completely. Before the pitch-dark field a white rod, lighted up and subjected to a displacement in space, leaves on the photographic plate the vestiges of its successive positions. It generates on the plane of the plate the projection of the figure in three dimensions which it has formed. In that way has been obtained (fig. 21, Pl. III) the projection of a sphere on a plane. A band of paper, white on one side, black on the other, was curved into a semicircular form and rotated about its chord. The figure so formed would have altogether the appearance of a solid sphere if a greater frequency of the illuminations had prevented the discontinuity of the surface generated.

Fig. 22 (Pl. III), the projection of a [one-sheeted] hyperboloid of revolution, was generated by a string placed oblique to the vertical axis round which it turned.

If figures with their relief are sought, the photographs should be taken with a stereoscopic apparatus. Fig. 23 (Pl. III) shows in this way an hyperboloid with its asymptotic cone. These examples, taken from very simple cases of geometry, enable us to imagine what variety of forms would be obtained with complex curves subjected to varied motions. There would be very simple experimental solutions of problems of geometry sometimes most complicated.

MECHANICS.—Mechanics is founded on the laws of motion, laws of spaces described, of velocities, and of accelerations. The difficulties



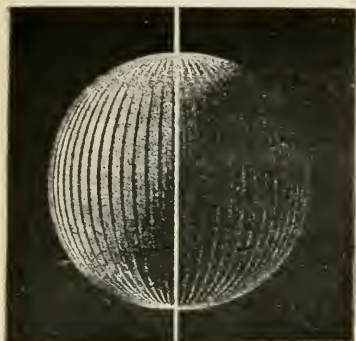

Fig. 21.

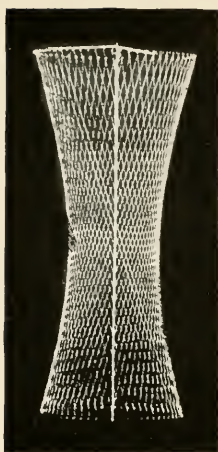

Fig. 22.

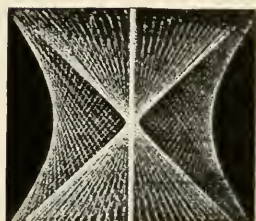
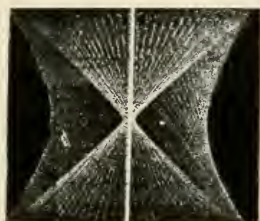

Fig. 23.

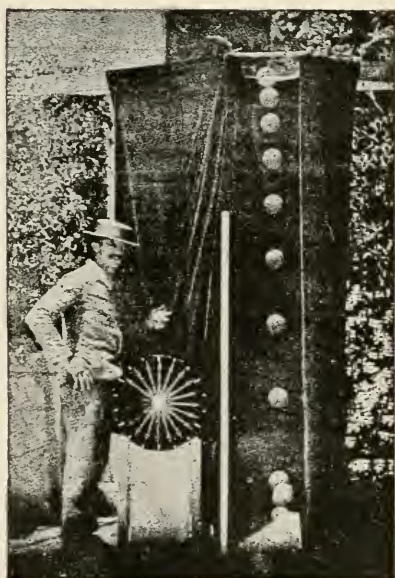

Fig. 24.

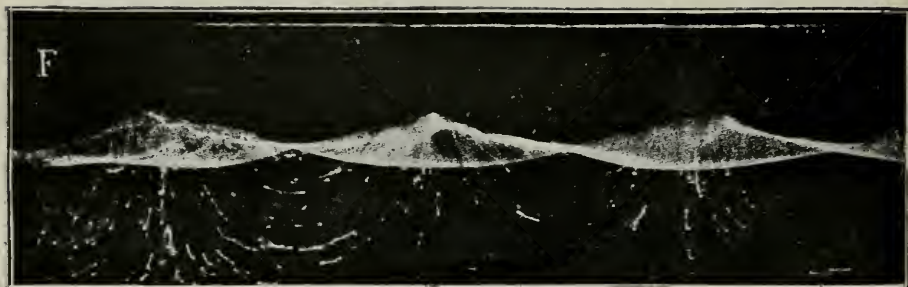

Fig. 25.



Fig. 26.

CHRONOPHOTOGRAPHS OF WATER IN MOTION.

which Galileo and Atwood surmounted to determine these laws will for the future be saved in all analogous cases for those who shall employ chronophotography for the purpose. We shall only have to allow the body whose motion (fig. 24, Pl. III) is to be studied to fall before the pitch-dark background, and its positions will be marked upon the sensitive plate; the chronograph will give the interval of time which elapses between the body's arrivals at the positions figured; the scale of millimeters will measure the distances described. The same arrangement enables us to make interesting studies of the resistance of the air.

Hydrodynamics is commonly taken to be one of the most complicated sciences. The nature of undulations, the nature of violent waves, the internal motions of molecules in a shaken liquid, the manner in which stream lines behave when they meet obstacles of different forms, all these questions are still discussed as if they were difficult. All these problems find their experimental solution in chronophotography.

All that is wanted is to render visible, and alone visible, before a dark background, those parts of the liquid of which we wish to know the motion. For that purpose into a canal formed of transparent plate glass is to be poured some very clear water. A mirror inclined at a convenient angle and placed under this canal reflects the light of the sun, which then traverses the liquid mass from below upward. The water is not illuminated; but at the surface of the water, at the point where the wall of the glass is moistened by the liquid, a meniscus is formed, and the under convex surface of this meniscus sends by total reflection a very bright thread of light, which oscillates like the surface of the liquid itself. The photographic objective will make upon the sensitive plate a photograph of this line with all its movements.

The interior of the liquid is not lighted up. In order to render certain points of this mass and to perceive the displacements which they undergo it is only necessary to put into suspension in the water small silvered pearls to which has been given the precise specific gravity of the liquid. These pearls by the agitation which they undergo will express the motion of the molecules of the water at different parts of the mass (fig. 25, Pl. IV).

Other phenomena of the same class can be studied by chronophotography. Thus, a thin inclined plane being presented to a liquid current, the bright pearls will express by the direction of their course the motion of liquid fillets. By the distances between their images they will express the rapidity of the current. A scale of millimeters immersed in the water will measure the extent of the motions, while the known interval of time which separates the flashes affords the means of evaluating the velocity. That having been explained, one glance at the scale diagram (fig. 26, Pl. IV) will suffice to show what movements will take place at the surfaces of liquids under conditions

however varied, and also how the molecules themselves will move at the different points throughout the mass.

*Motions of the air.*—An analogous arrangement makes it possible to render visible by means of smoke certain fillets of air in the midst of a regular current. We ascertain in that case by chronophotography the changes of direction and of velocity of this current when it meets obstacles of different forms.

In a large canal having walls of plate glass and before a dark background a draft of air is created by means of a ventilator. In order to regulate the current it is filtered through a very fine silk gauze. At the top of the canal, we set free, by means of a series of little tubes, fillets of smoke which descend parallel to one another like the three cords of a lyre. Now, if we place in the interior of the canal obstacles of different forms, we immediately see the threads bend on these obstacles, slide over them, and form behind them eddies of varied forms. Figs. 27, 28, and 29 (Pl. V) show the same experiment under different conditions. In fig. 27 a magnesium flash light illuminates the phenomenon for a very short time. We see how the fillets of air lick the plane, slide on it, and form backwater behind it. Fig. 28 shows the same phenomenon with chronophotographic indications. The series of little tubes which bring the smoke are made to vibrate ten times a second, so that the smoke no longer appears in rectilinear fillets but as sinusoidal undulations, more or less elongated at each point according to the velocity of the current. The motion slows up upon approaching an obstacle and is accelerated at the sides of the obstacle. It will be remarked that the conceptions of time and space which are peculiar to chronophotography are brought together in this experiment. Finally, in fig. 29 the chronography is suppressed.

The illumination is no longer instantaneous, but is produced by the combustion of magnesium ribbon, so that a sort of mean state of the current is recorded.

*Resistance of the air to flying apparatus.*—One of the applications of the previous experiments is to make comprehensible the action of the air on apparatus of different



FIG. 30.

forms which move in this fluid. Fig. 30 shows more directly the effects of this resistance. It shows how a little paper soaring model left to fall vertically behaves and how it receives from the resistance of the air changes of direction and of velocity which are faithfully represented.

*Vibrations of cords.*—These motions are easily seen upon bright cords vibrating before a dark background. Our learned fellow-aca-

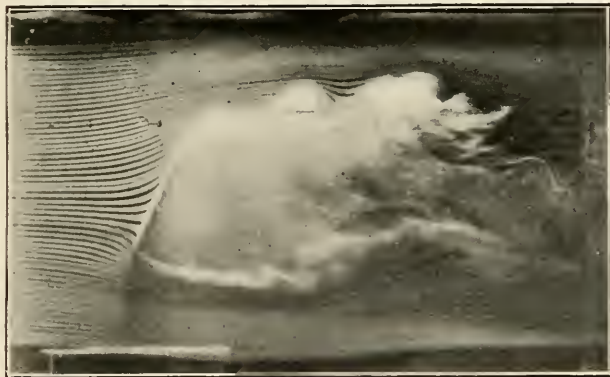

Fig. 27.

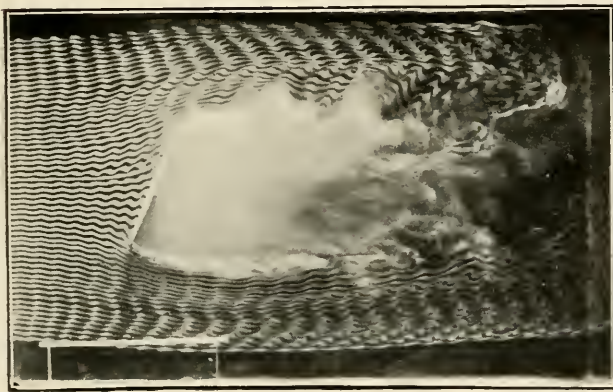

Fig. 28.

AIR CURRENTS PASSING OBSTRUCTIONS.

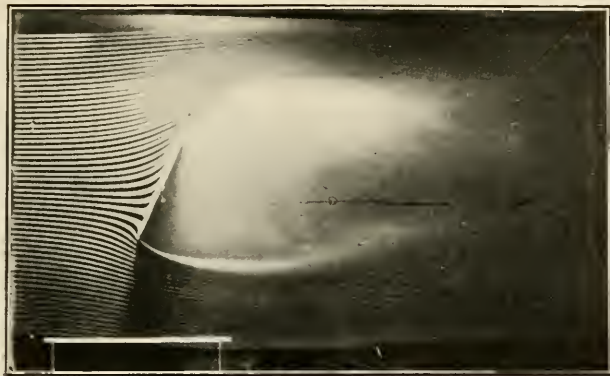

Fig. 29.





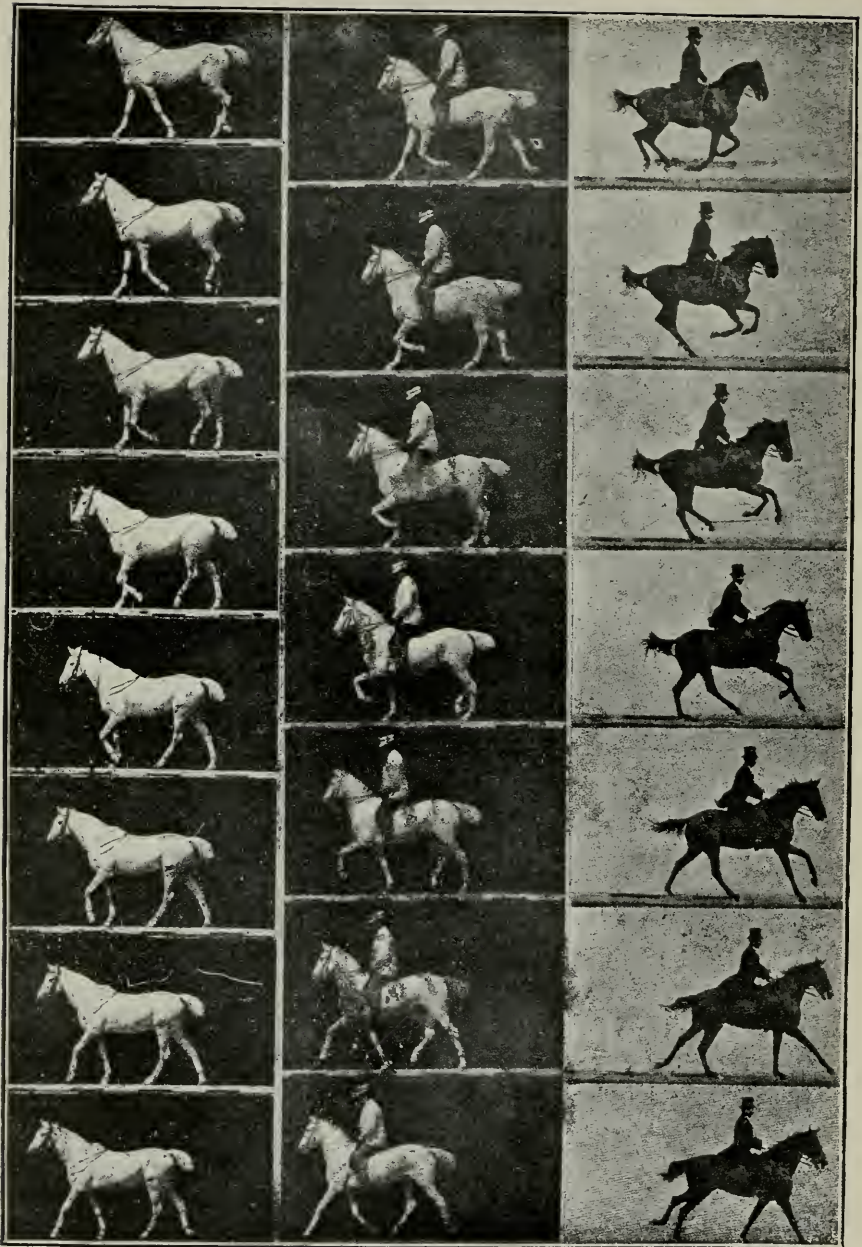

Fig. 32.

Fig. 33.

Fig. 34.

CHRONOPHOTOGRAPHS OF HORSES IN MOTION.



demician, A. Cornu, succeeded in this way in rendering perceptible in a cord vibrations of three kinds—the longitudinal, the transversal, and the torsional. A very light little mirror attached to the cord indicated these three kinds of motion on a plate having a uniform translation. Fig. 31 is the negative resulting from this experiment.

PHYSIOLOGY.—It is to the physiological study of the different gaits of animals and to the functional motions of their different organs that chronophotography has principally been applied. Some types of the experiments which it has rendered possible may here be illustrated.

*Terrestrial locomotion.*—The series of photographs taken on moving films have represented all the phases of motion of man and of quadrupeds. Thus figs. 32, 33, and 34 (Pl. VI) represent the three normal gaits of the horse.

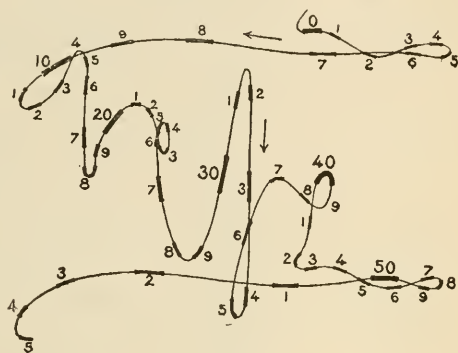

FIG. 31.

One can easily follow the succession of attitudes during the advance of the animal. The sequence of time is from above downward. A disputed question of animal mechanics was whether a cat turns over in falling, and, if so, how she does it without any application of external force. Experiment has proved that, as a fact, she does so, thus enabling mechanicians to correct a current error of classical treatises.

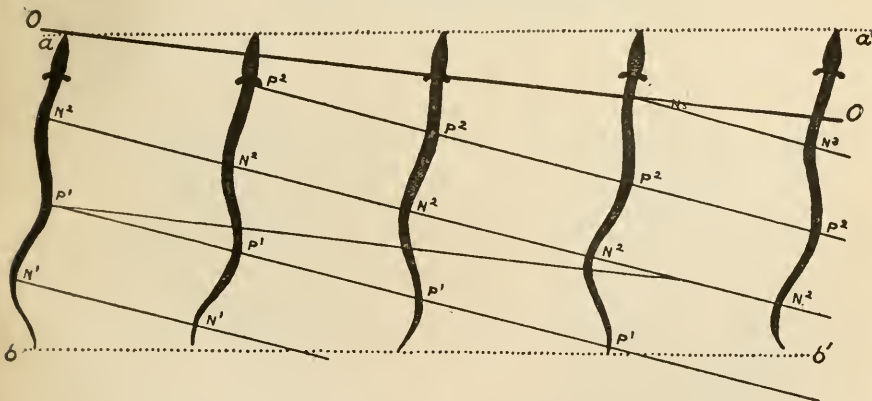

FIG. 35.

*Locomotion in water* has also been studied by film photography. These photographs are brought together in order to facilitate the comparison of them. The locomotion of the eel (fig. 35) shows the progression of undulations of the body of the animal from head to tail. Lines are drawn to show the direction of motion and the advance of the animal.

In certain fish the undulations take place in the lateral fins. The ray (fig. 36, Pl. VII) is shown in side view, swimming without advancing, its progress being impeded. The same fish seen from the front has motions which strongly recall those of a flying bird.

*Locomotion in the air.*—Not only the flight of birds, but that of insects, studied by chronophotography, shows the details of its mechanism. The extreme rapidity of these motions—several hundred per second—requires extremely short exposures. To avoid any defect of sharpness due to the velocity of the wing, the writer has reduced the duration of the flash to less than one twenty-thousandth of a second. Only isolated photographs have been obtained, but even these are highly instructive. Fig. 37 (Pl. VII) is a motionless crane-fly; fig. 38 (Pl. VII) shows it in flight. The torsion of the wing under the resistance of the air, a phenomenon which theory had predicted, and which explains the mechanism of insect flight, is shown in the picture.

*Functional motions.*—Independently of acts of locomotion, the different parts of the body execute various movements, the observation of which is in some cases excessively difficult. In speech and in mastication the lower jaw takes displacements that one would not have anticipated. The ribs, in respiration, rise and separate in a way that was of old unknown. In certain joints the bones move about a fixed center, while in others there is a rolling motion of the condyles over the surface in contact with them. Chronophotography on the dead-black background gives a drawing to scale of all these motions. Bright lines or points fixed to the organ under examination interpret the trajectory upon the photographic plate.

Thus the motions of the lower jaw in the act of opening the mouth are represented (fig. 39, Pl. VIII) by those of a rod bent at an angle and forced to move with the jaw. It will be seen that the motion is not a rotation round the joint, but takes place about instantaneous centers in the upright branch, while the condyle itself slides over the surface of the glenoid cavity, which is convex downward.

In respiration bright points fixed upon the ribs are displaced with the latter and interpret the motions of the rising ribs on a circular arc.

The heart of an animal, laid bare and brilliantly illuminated, gives on the moving film the succession of systole and diastole of its auricles and ventricles. The motions of the eyes themselves have been studied at the physiological station by M. Orchansky. He has chronophotographed the dotted trajectory of the eyes in reading, and in this motion has been able to distinguish the components, due respectively to the ocular muscles and to the displacements of the head.

*Motions of the air in the utterance of the vowels.*—The eminent physicist, R. Kœnig, conceived the idea of making the sonorous vibrations due to instruments or to the voice act upon capsules with membranous

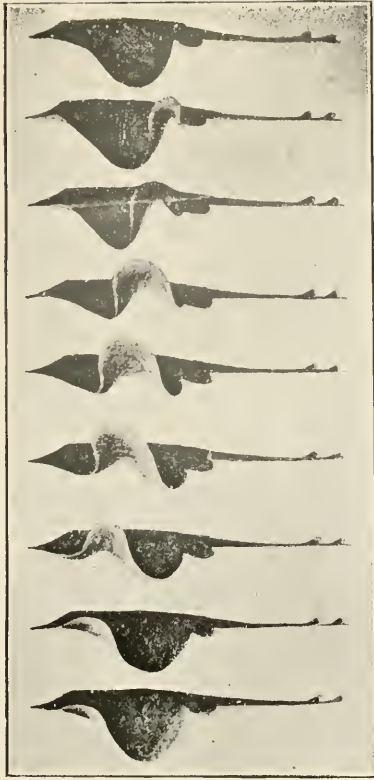

Fig. 36.



Fig. 37.



Fig. 38.

CHRONOPHOTOGRAPHS OF RAY AND CRANE-FLY.



Fig. 39.

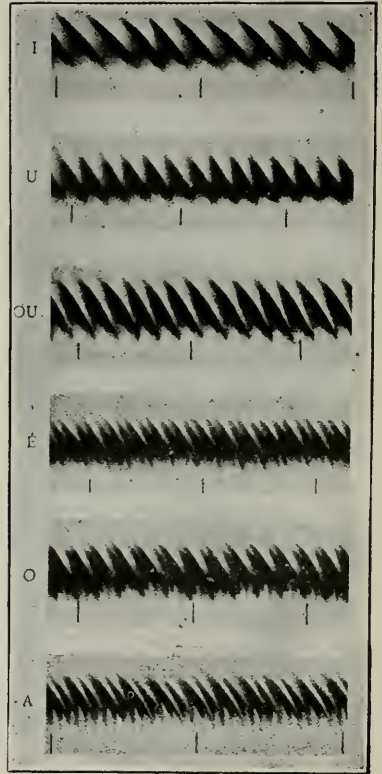

Fig. 40.

CHRONOPHOTOGRAPHS OF JAW MOVEMENT, AND OF AIR MOTION IN VOWEL SOUNDS

walls placed on little gas-burners. These "manometric flames" vibrate in unison with the sonorous waves. Their images, dissociated in a revolving mirror, appear with indented mantling of various forms, according to the sound. But this fugitive phenomenon could not be fixed by photography until M. Marage, who has charge of the acoustic work at the Physiological Station, rendered the flames photogenic by substituting acetylene for ordinary illuminating gas. He has taken the photographs by chronophotography on a ribbon of sensitized paper having a translation of 2 meters per second (100 feet in 0.254 minute). Fig. 40 (Pl. VIII), shows the vibrations of the air for the French vowels *i, u, ou, é, o, a*. At the same time as the vibrations of the vowels, those of a special burner acted on by a tuning fork of 45 V. D. are photographed also, so as to determine the pitch.

*Representations of motions in scale pictures conformed to separate photographs.*—The impressions by chronophotographs on a moving film, complete as they are, are hard to utilize, on account of the difficulty of comparing the separate photographs. In some cases this comparison can be facilitated by bringing the photographs together. But it would be more satisfactory to be able to arrange them, each in its place, on a single picture to scale. The writer has accomplished this by means of successive projections and counter proofs on the same sheet of paper.

Let a gymnast throw a weight. (This is chronophotographed on a ribbon.) Let us project the first photograph and carefully counter-prove the form of the body.<sup>a</sup>

After this first projection, let us project the second photograph upon the same sheet, and then a third, taking care to preserve the registry exact by fixed points which we have chosen. (That is, the horizontal line and object *r* will have been sharply drawn on the back of the drawing paper; and in making subsequent projections care is taken to have that line and object fall upon precisely the same places.) We shall thus have obtained a series of counter-proofs representing the successive attitudes of the gymnast. Fig. 41 has been constructed in this way. It affords complete information as to the extent and velocity of each of the motions represented.

In this case only every third photograph has been drawn, in order to avoid confusion in the picture to scale; but while reducing the num-

<sup>a</sup> I suppose he means that the perverted negative is projected, or in some way that the projection is perverted, and that the projection is made on a board. This projection must show the fixed object *r* (at the left of the horizontal line), which, with the horizontal line, is photographed from nature in all the photographs. He attaches, I suppose, to the board a sheet of carbon paper, and over it a sheet of drawing paper, face down. The projection appears on the back of the latter, and he marks with an agate stylus the outlines of the gymnast's body, the horizontal line, and the object *r*. These outlines are thus drawn correctly on the face of the drawing paper. That is how I understand his description.—TRANSLATOR.

ber of images of the athlete we might show all the successive positions of the weight, which would then have been very numerous. The series of these positions would have given the law of the motion impressed

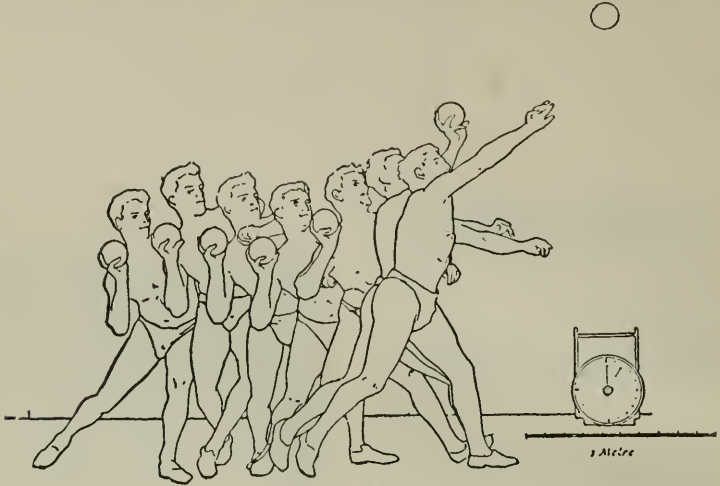

FIG. 41.

on the projectile, and the acceleration would have given in its turn the measure of the forces developed by the gymnast at each instant.

We can even push the analysis of muscular action so far as to give, in the successive pictures to scale, the positions of the skeleton within

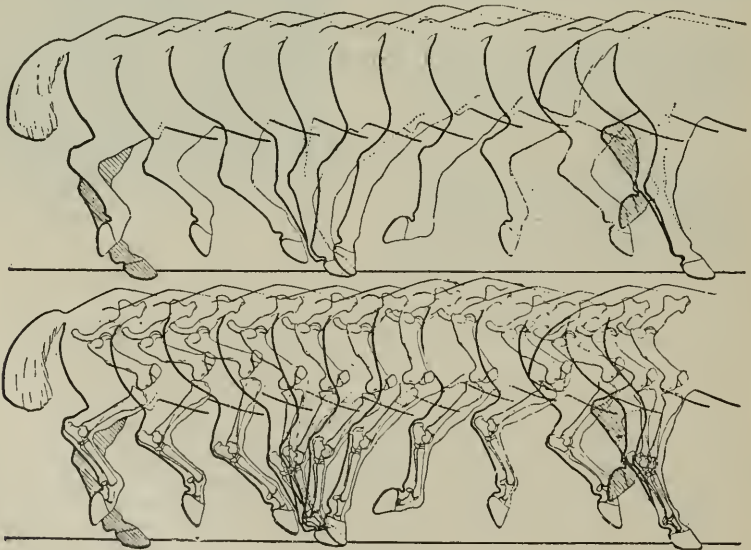

FIG. 42.

the subject, with the phases of extension and contraction of the principal muscles, whose insertions upon the skeleton are, of course, known. Fig. 42 contains such details.

This last application of chronophotography is sometimes somewhat laborious. It is only mentioned to show the extreme power of the method and the multiplicity of its applications.

In closing it may be added that since the exhibition new applications of chronophotography have been made at the physiological station, which promise the experimental solution of certain problems hitherto looked upon as insoluble.

---

[Subsequent notes by Dr. Marey, translated from the *Comptes Rendus* of the Academy of Sciences, Vol. CXXXII, p. 1291, meeting of June 3, 1901.]

Since the communication which I had the honor to make to the Academy on the 27th of May, 1900, I have seen that my apparatus needed to be entirely reconstructed in a better form, but the resources of my own laboratory did not permit it.

Our correspondent, Mr. Langley, who is interested in these studies, obtained from the Smithsonian Institution, whose Secretary he is, a subsidy which has permitted me to resume my experiments, and to present to the Academy these new results. I have also awaited the result of the remarkable experiments of Professor Hele-Shaw, and it has seemed to me desirable to bring together these two kinds of research, which have a common purpose, that of fixing by means of permanent images phenomena which escape direct observation.

Besides this, since my last communication I have learned of the labors of Mr. L. Mach, which are so closely related to my own that I notice them in giving the history of the new methods which seem destined to numerous applications.

It was on the 11th of March, 1893, that I had the honor of presenting to the Academy my first experiments, made by means of chronophotography, on liquid waves or movements of the internal molecules of these waves, and also of the changes of speed and direction in currents which meet bodies of diverse forms. After Mr. Mach's communication of his experiments on the behavior of a current of air under analogous circumstances, he developed this research in a later communication on the use of an inhaling turbine, passing a steady current of air into a quadrangular prismatic tube, whose section was 18 by 24 cm. The face of this tube, turned toward the observer, was formed of transparent glass; the opposite face was blackened to form a dark chamber, and an arc lamp projected its light into the interior of the tube.

Mr. Mach placed bodies of different forms and made of transparent substances in the air current, and took different ways to render the movements of the air in the vicinity of the bodies visible. Sometimes he projected light bits of paper or silk in the air current sometimes fine dust, sometimes smoke, and sometimes he hung flexible silk

threads, which the current moved along; while sometimes he explored the direction of the air movements by means of little gas flames, which he applied at different points of the bodies that were in the tube. But the method which gave him the best results was that of Schlieren, which consists of rendering visible the movements of very small streams of air by changing the index of refraction, which is done by sending a current of hot air into a colder current. The small streams or threads, which are warmed, then show either clearer or darker than the surrounding air, and the magnesium flash light permits us to photograph the phenomenon.

Mr. Mach's experiments have given results quite conformable to those which I obtained in the movements of liquids under similar circumstances. So, for instance, on meeting the bodies the air current divides and re-forms behind them without producing many whirlpools, and when the plane is inclined under different angles and solids of different forms these disturb the air as if it were water. Mr. Mach measured the speed of his air currents by means of an anemometer, regulating the indications of the instrument by an acoustic method devised by his father, Prof. E. Mach. The vibration caused by a Koenig flame introduced into the air current gives the appearance of a cluster of little clouds, which move on while keeping their respective distance, and as the latter correspond to known intervals of time they enable one to measure the speed of the current.

Mr. Mach noticed a lack of fixity in the direction of air currents, which showed continual oscillations, and he attributes these movements to changes in the aerodynamic pressure.

These studies were not known to me when I presented to the Academy the result of experiments where I had studied the action of different bodies in an air current placed in conditions identical to those which I had studied with the liquid currents. To follow the movements of the air, I used smoke threads, which, drawn along with the air by the action of ventilators, entered with it and at the same speed into the glass tube. The air and smoke were filtrated through fine-meshed cloth and advanced parallel to each other in the interior of the tube as long as the current met no obstacle.

These experiments, like those of Mr. Mach, have shown that at the rates employed air and liquids behave in substantially the same way.

At this time Mr. Bertin, an engineer of the Navy, brought me into correspondence with Mr. Hele-Shaw, of Liverpool, who had been pursuing similar experiments in closed chambers for several years. The clear images given by photographing colored glycerin threads showed how the incompressibility of liquids affect eddies in an inextensible space, while the eddies always occur in different degrees behind bodies immersed in an air current, or even in a liquid current if it is moving in an open tube.



In the construction of my new apparatus the section of the air tube was increased from 20 to 50 cm. and the number of threads of smoke from 20 to 58. The filtering cloths were replaced by silk gauzes with a very small mesh, and I finally introduced into the experiment a chronographic system which allows us to measure the speed of each smoke thread in different parts of its course. For this purpose the system of little tubes which bring the smoke threads which are about to be aspirated is subject to a lateral shake, repeated ten times every second. An electric vibrator regulates this movement with the above-named frequency, and under this influence the smoke threads do not form straight, parallel lines, but sinusoidal curves. These inflections are preserved during their whole path. In the interior of the tube a small scale 20 cm. long, in the same plane as the smoke threads, serves to measure the space traversed by the molecules of air in each tenth of a second.

Some examples of the results obtained will enable us to appreciate the progress which has been made in the new construction.

When there is no obstacle offered to the air current the smoke threads remain rectilinear and parallel. If we place an inclined plane in the current the smoke threads enlarge in meeting it, which indicates that they lose velocity before following opposite directions. Some mount toward the upper edge of the plane, others glide upon each other without mingling and escape by the lower edge. On each side of the obstacle the smoke threads continue their motion very close together, leaving behind the inclined plane a space where the air is motionless, and only gives a smoky cloud. This space where the eddies or whirlpools occur is larger in proportion as the obstacle to the air current is larger.

To note the speed of the air current in different parts of its course we repeat the experiment, subjecting the smoke threads to the above-mentioned vibrations, and then the threads instead of being rectilinear present a series of lateral inflections which are preserved during all their course. These inflections remain equi distant if the speed of the current is everywhere the same, but if the current speed diminishes the inflections are closer; if it is rapid, they are more distant from each other, and the space moved over in a given time is measured by means of the metric scale.

The figures which we have just seen are observed by a magnesium flash; that is to say, in so short a time, that each smoke thread seems immovable. If the light lasted longer the aspect of the figure would change and give the further condition of the air current as we see it in fig. 4<sup>a</sup>, where the light produced by the prolonged combustion lasts about seven seconds.

---

<sup>a</sup> This fig. 4 corresponds to fig. 29, Pl. v, of the foregoing paper on chronophotography, where are also shown other figures here referred to by Doctor Marey.

We can not enumerate all the numerous applications of this method, since the form and dimensions of the bodies in the air current and the velocity of this current itself can be varied without end.

I have never observed the "jumps" noted by Mr. Mach, as making the current deviate from one side to another. These "jumps" might possibly be due to the unequal temperature of the moving air. It may be regarded, I think, as a proof of the precision of my method that if an experiment is repeated under the same conditions the observed images are identical and superposable on each other.

I believe I may add that this method will give the mechanical solution of many problems relating to propelling apparatus, fluids, and questions of ventilation, etc.

[To Mr. Marey's interesting article we add two other illustrations from his own experiments, since received from him by the Smithsonian Institution. These are numbered *a* and *b*, *a* being a form producing very little eddy, while *b* (a form not noticeably different) produces a very great one. These seem to be well calculated to show the importance and the delicacy of the method.]

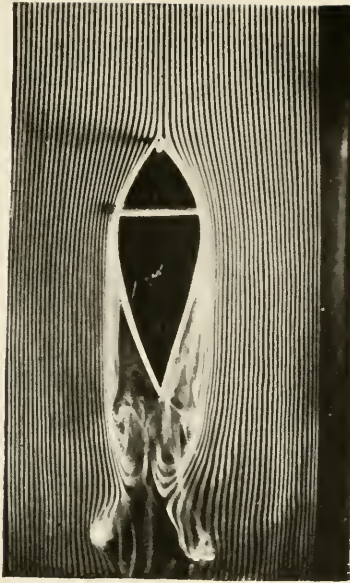

A.

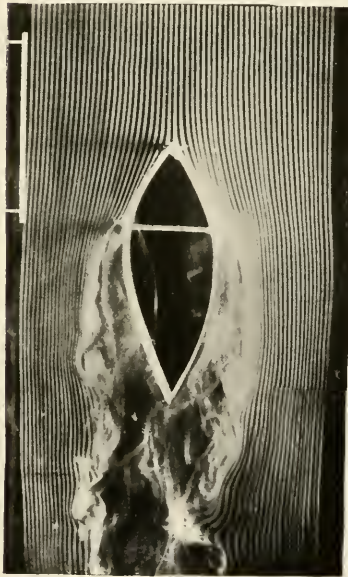

B.

AIR CURRENTS PASSING CURVED OBJECT.



## THE AIMS OF THE NATIONAL PHYSICAL LABORATORY OF GREAT BRITAIN.<sup>a</sup>

---

By R. T. GLAZEBROOK, F. R. S.,

*Director of the National Physical Laboratory.*<sup>b</sup>

---

A speaker who is privileged to deliver an experimental lecture from this place is usually able to announce some brilliant discovery of his own, or at least to illustrate his words by some striking experiment. To-night it is not in my power to do this, and I am thereby at a disadvantage. Still, I value highly this opportunity which has been given me of making known to this audience the aims and purpose of the National Laboratory.

The idea of a physical laboratory in which problems bearing at once on science and industry might be solved is comparatively new. The Physikalisch-technische Reichsanstalt, founded in Berlin by the joint labors of Werner von Siemens and von Helmholtz during the years 1883-1887, was, perhaps, the first. It is less than ten years since Dr. Lodge, in his address to Section A of the British association, outlined the scheme of work for such an institution here in England.

Nothing came of this. A committee met and discussed plans, but it was felt to be hopeless to approach the Government, and without Government aid there were no funds. Four years later, however, the late Sir Douglas Galton took the matter up. In his address to the British association in 1895, and again in a paper read before Section A, he called attention to the work done for Germany by the Reichsanstalt, and to the crying need for a similar institution in England. The result of this presidential pronouncement was the formation of a committee which reported at Liverpool, giving a rough outline of a possible scheme of organization.

---

<sup>a</sup> Reprinted, by permission, from *Popular Science Monthly*, Vol. LX, December, 1901.

<sup>b</sup> A discourse delivered at the Royal Institution. See also article by Henry S. Carhart in the *Smithsonian Report* for 1900 giving a description of the Physikalisch-technische Reichsanstalt with several illustrations omitted from the present paper.—  
EDITOR.

A petition to Lord Salisbury followed, and as a consequence a treasury committee, with Lord Rayleigh in the chair, was appointed to consider the desirability of establishing a national physical laboratory. The committee examined over thirty witnesses, and then reported unanimously, "That a public institution should be founded for standardizing and verifying instruments, for testing materials, and for the determination of physical constants." It is natural to turn to the words of those who were instrumental in securing the appointment of this committee and to the evidence it received in any endeavor to discuss its aims. As was fitting, Sir Douglas Galton was the first witness to be called. It is a source of sorrow to his many friends that he has not lived to see the laboratory completed.

And here I may refer to another serious loss which in the last few days this laboratory has sustained. Sir Courtenay Boyle was a member of Lord Rayleigh's committee, and as such was convinced of the need for the laboratory and of the importance of the work it could do. He took an active part in its organization, sparing neither time nor trouble; he intended that it should be a great institution, and he had the will and the power to help. The country is the poorer by his sudden death.

Let me now quote some of Sir Douglas Galton's evidence:

Formerly our progress in machinery was due to accuracy of measurement, and that was a class of work which could be done, as Whitworth showed, by an educated eye and educated touch. But as we advance in the applications of science to industry we require accuracy to be carried into matters which can not be so measured. In the more delicate researches which the physical, chemical, and electrical student undertakes he requires a ready means of access to standards to enable him to compare his own work with that of others.

Or again:

My view is that if Great Britain is to claim its industrial supremacy, we must have accurate standards available to our research students and to our manufacturers. I am certain that if you had them our manufacturers would gradually become very much more qualified for advancing our manufacturing industry than they are now. But it is also certain that you can not separate some research from a standardizing department.

Then after a description of the Reichsanstalt he continues:

What I would advocate would be an extension of Kew in the direction of the second division of the Reichsanstalt, with such auxiliary research in the establishment of itself as may be found necessary.

The second division is the one which takes charge of technical and industrial questions.

Professor Lodge again gave a very valuable summary of work which ought to be done. Put briefly it was this:

1. Pioneer work.
2. Verification work.

3. Systematic measurements and examinations of the properties of substances under all conditions.

4. The precise determination of physical constants.

5. Observational work, testing instruments.

6. Constructional work (gratings, optical glass).

7. Designing new and more perfect instruments.

Such were the views of those who took a prominent part in the founding of the institution.

It is now realized, at any rate by the more enlightened of our leaders of industry, that science can help them. This fact, however, has been grasped by too few in England; our rivals in Germany and America know it well, and the first aim of the laboratory is to bring its truth home to all, to assist in promoting a union which is certainly necessary if England is to retain her supremacy in trade and in manufacture, to make the forces of science available for the nation, to break down by every possible means the barrier between theory and practice, and to point out plainly the plan which must be followed, unless we are prepared to see our rivals take our place.

“Germany,” an American writer,<sup>a</sup> who has recently made a study of the subject, has said, “is rapidly moving toward industrial supremacy in Europe. One of her most potent factors in this notable advance is the perfected alliance between science and commerce existing in Germany. Science has come to be regarded there as a commercial factor. If England is losing her supremacy in manufactures and in commerce, as many claim, it is because of English conservatism and the failure to utilize to the fullest extent the lessons taught by science, while Germany, once the country of dreamers and theorists, has now become intensely practical. Science there no longer seeks court and cloister, but is in open alliance with commerce and industry.” It is our aim to promote this alliance in England, and for this purpose her National Physical Laboratory has been founded.

It is hardly necessary to quote chapter and verse for the assertion that the close connection between science and industry has had a predominant effect on German trade. If authority is wanted, I would refer to the history of the anilin dye manufacture, or to take a more recent case, to the artificial indigo industry in which the success of the Badische Company has recently been so marked. The factory at Ludwigshaven started thirty-five years ago with 30 men. It now employs over 6,000, and has on its staff 148 trained scientific chemists. And now when it is perhaps too late the Indian planters are calling in scientific aid and the Indian government is giving some £3,500 a year to investigation.

As Professor Armstrong, in a recent letter to the Times, says: “The truly serious side of the matter, however, is not the prospective loss

---

<sup>a</sup> Prof. H. S. Carhart.

of the entire indigo industry so much as the fact that an achievement such as that of the Badische Company seems past praying for here."

Or, to take another instance, scientific visitors to the Paris Exhibition last year must have been struck by the German exhibit of apparatus. German instrument makers combined to produce a joint exhibit; a strong committee was formed. Under the skillful editorship of Dr. Lindeck, of the Reichsanstalt, a catalogue was compiled, in which, by a judicious arrangement of cross references, it was easily possible to find either the exhibit of a particular firm or the apparatus of a particular class. This was printed in German, English, and French, and issued freely to visitors. Dr. Drosten, the representative of the exhibitors in charge, or one of his assistants, was ever ready to give information and advice. To one who wished, as I did, to see

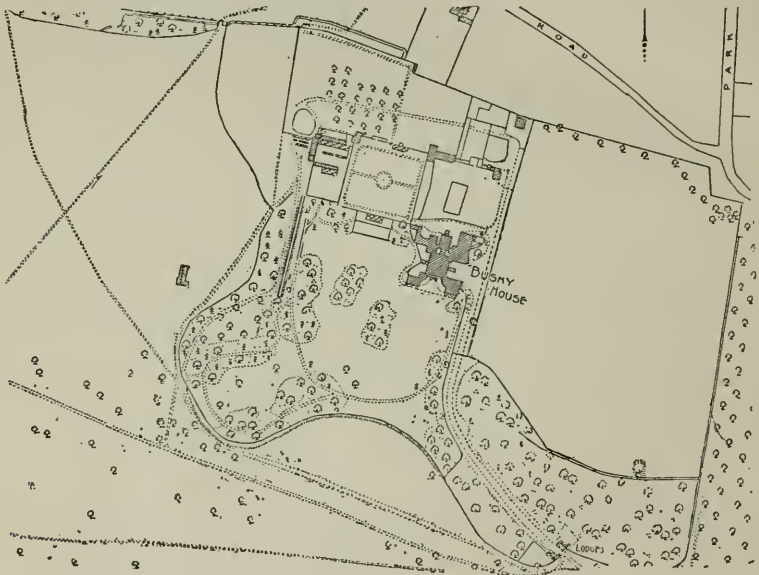

Plan of grounds.

the most modern forms of German apparatus, the exhibit was a very real help. \* \* \*

And now having stated in general terms the aims of the laboratory and given some account of the progress in general, let me pass to some description of the means which have been placed at our disposal to realize those aims. I here wish, if time permits, to discuss in fuller detail some of the work which, it is hoped, we may take up immediately.

The laboratory is to be at Bushy House, Teddington. I will pass over the events which led to this change of site from the old Deer Park at Richmond to Bushy. It is sufficient to say that at present Kew





BUSHY HOUSE, EAST FRONT.



BUSHY HOUSE, SOUTH FRONT.



Observatory in the Deer Park will remain as the observatory department of the laboratory, and most of the important verification and standardization work, which in the past has been done there, will still find its home in the old building. The house was originally the official residence of the ranger of Bushy Park. Queen Anne granted it in 1710 to the first Lord Halifax. In 1771 it passed to Lord North, being then probably rebuilt. Upon the death of Lord North's widow, in 1797, the Duke of Clarence, afterwards William IV, became ranger. After his death, in 1837, it was granted to his widow, Queen Adelaide, who lived here until 1849. At her death it passed to the Duc de Nemours, son of King Louis Philippe, and he resided here at intervals until 1896. In spite of this somewhat aristocratic history it will make an admirable laboratory. The building is very solid and substantial.

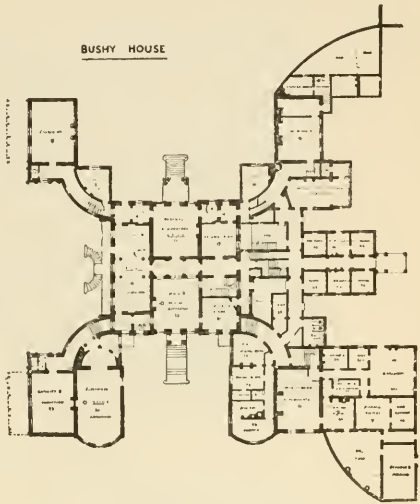

Bushy House, ground plan.

There is a good basement under the main central block, with roof of brick groining, which makes a very steady support for the floor above.

Such is the home of the laboratory. It may be of interest to compare it with the Reichsanstalt.

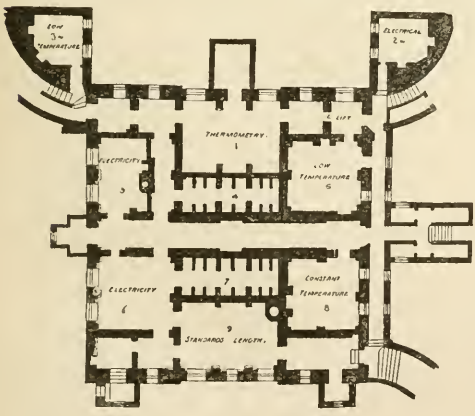

Bushy House, basement.

The floor space available is much less than that of the Reichsanstalt. But size alone is not an unmixed advantage; there is much to be said in favor of gradual growth and development, provided the conditions are such as to favor growth. Personally I would prefer to begin in a small way, if only I felt sure I was in a position to do the work thoroughly, but there is danger of starvation. Even

with all the help we get in freedom from rent and taxes, outside repairs and maintenance, the sum at the disposal of the committee is too small. Fourteen thousand pounds will not build and equip the laboratory. Four thousand pounds a year will not maintain it as it ought to be

maintained. Contrast this with the expenditure on the Reichsanstalt<sup>a</sup> or with the proposals in America where the bill for the establishment of a laboratory has just passed, and an expenditure of £60,000 on building and site and £9,000 a year has been authorized. \* \* \*

Science is not yet regarded as a commercial factor in England. Is there no one who, realizing the importance of the alliance, will come

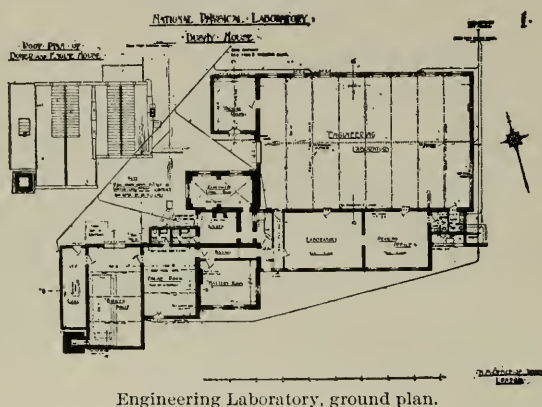

forward with more ample funds to start us on our course with a fair prospect of success? One real friend has recently told us in print that the new institution is on such a microscopic scale that its utility in the present struggle is more than doubtful. Is there no statesman who can grasp the position and see that, with, say, double the income, the chances of our doing a great work would be increased a hundred-

<sup>a</sup> *Capital expenditure on the Reichsanstalt.*

DIVISION I.	
Site, the gift of Dr. Siemens .....	£25, 000
Cost of buildings .....	34, 275
Fittings and furniture .....	2, 700
Machinery and instruments .....	4, 100
	£66, 075
DIVISION II.	
Site .....	£18, 600
Buildings .....	88, 000
Fittings and furniture .....	5, 400
Machinery and instruments .....	23, 550
	135, 550
	201, 625
ANNUAL EXPENDITURE.	
Salaries and wages .....	£10, 300
Maintenance of buildings, apparatus, etc. ....	6, 350
	16, 650

See description, with illustrations of the Reichsanstalt, by Henry S. Carhart, printed in the Smithsonian Report for 1900, pages 403-415.

fold? The problems we have to solve are hard enough; give us means to employ the best men and we will answer them; starve us and then quote our failure as showing the uselessness of science applied to industry. There is some justice in the criticism of one of our technical

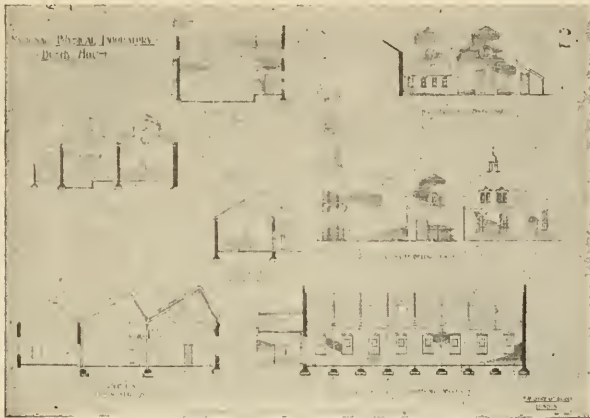

Engineering Laboratory, elevations and Sections.

papers. I have recently been advertising for assistants, and a paper in whose columns the advertisement appears writes:

"The scale of pay is certainly not extravagant. It is, however, possible that the duties will be correspondingly light."

I have thus summarized in a brief manner the aims of the laboratory and have indicated the effect which the application of science to industry has had on one branch of trade in Germany. And now let me illustrate these aims by a more detailed account of some of the problems of industry which have been solved by the application of science, and then of some others which remain unsolved and which the laboratory hopes to attack. The story of the Jena glass works is most interesting; we will take it first.

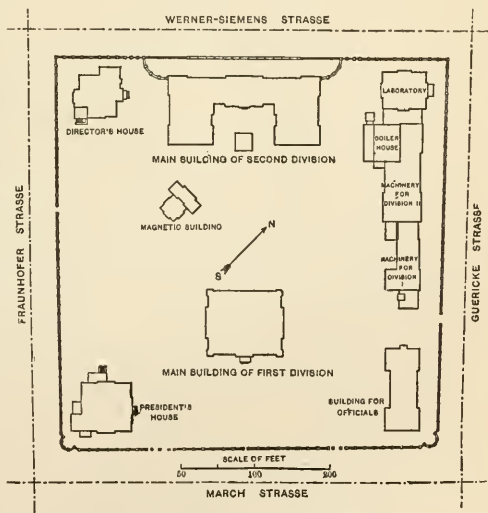

Reichsanstalt, general plan.

An exhibition of scientific apparatus took place in London in 1878. Among the visitors to this was Professor Abbé, of Jena, and in a report he wrote on the optical apparatus he called attention to the need for progress in the art of glass making if the microscope were to advance and to the necessity for obtaining

glasses having a different relation between dispersion and refractive index than that found in the material at the disposal of opticians. Stokes and Harcourt had already made attempts in this direction, but with no marked success. In 1881 Abbé and Schott at Jena started their work. Their undertaking, they write five years later in the first catalogue of their factory, arose out of a scientific investigation into the connection between the optical properties of solid amorphous fluxes and their chemical constitution. When they began their work some 6 elements only entered into the composition of glass. By 1888 it had been found possible to combine with these in quantities up to about 10 per cent 28 different elements, and the effect of each of these on the refractive index and dispersion had been measured. Thus, for example, the investigators found that by the addition of boron the ratio of the length of the blue end of the spectrum to that of the red was increased; the addition of fluorine, potassium, or sodium produced the opposite result. Now in an ordinary achromatic lens of crown and flint, if the total dispersion for the two be the same, then for the flint glass the dispersion of the blue end is greater; that of the red less than for the crown; thus the image is not white, a secondary spectrum is the result. Abbé showed, as Stokes and Harcourt had shown earlier, that by combining a large proportion of boron with the flint its dispersion was made more nearly the same as that of the crown, while by replacing the silicates in the crown glass by phosphates a still better result was obtained, and by the use of three glasses three lines of the spectrum could be combined. The spectrum outstanding was a tertiary one and much less marked than that due to the original crown and flint glass. The modern microscope became possible.

The conditions to be satisfied in a photographic lens differ from those required for a microscope. Von Seidel had shown that with the ordinary flint and crown glasses the conditions for achromatism and for flatness of field can not be simultaneously satisfied. To do this we need a glass of high refractive index and low dispersive power or vice versa; in ordinary glasses these two properties rise and fall together. Thus crown glass has a refractive index of 1.518 and a dispersive power of 0.0166, while for flint the figures are 1.717 and 0.0339. By introducing barium into the crown glass a change is produced in this respect. For barium crown the refractive index is greater and the dispersive power less than for soft crown. With two such glasses, then, the field can be achromatic and flat. The wonderful results obtained by Dallmeyer and Ross in this country, by Zeiss and Steinheil in Germany, are due to the use of new glasses. They have also been applied with marked success to the manufacture of the object glasses of large telescopes.

But the Jena glasses have other uses besides optical. "About twenty years ago"—the quotation is from the catalogue of the German

exhibition—"the manufacture of thermometers had come to a dead stop in Germany, thermometers being then invested with a defect, their liability to periodic changes, which seriously endangered German manufacture. Comprehensive investigations were then carried out by the Normal Aichungs commission, the Reichsanstalt, and the Jena glass works, and much labor brought the desired reward." The defect referred to was the temporary depression of the ice point which takes place in all thermometers after heating. Let the ice point of a thermometer be observed; then raise the thermometer to say 100° and again observe the ice point as soon as possible afterwards; it will be depressed below its previous position; in some instruments of Thuringian glass a depression of as much as 0.65° C. had been noted. For scientific purposes such an instrument is quite untrustworthy. If it be kept at say 15° and then immersed in a bath at 30° it will be appreciably different from that which would be given if it were first raised to say 50°, allowed to cool quickly just below 30°, and then put into the bath. This was the defect which the investigators set themselves to cure.

*Depression of freezing point for various thermometers.*

	Degree.
Humboldt, 1835.....	0.06
Greiner, 1872.....	.38
Schultzer, 1875.....	.44
Rapps, 1878.....	.65
English glass.....	.15
Ver Deer.....	.08
16'''.....	.05
59'''.....	.02

*Analysis of glasses.*

	SiO <sub>2</sub>	Na <sub>2</sub> O	CaO	Al <sub>2</sub> O <sub>3</sub>	ZnO	B <sub>2</sub> O <sub>3</sub>
16'''—67.5		14	7	2.5	7	2
59'''—72		11		5		12

Weber had found in 1883 that glasses which contain a mixture of soda and potash give a very large depression. He made in 1883 a glass free from soda with a depression of 0.1°. The work was then taken up by the Aichungs commission, the Reichsanstalt, and the Jena factory. Weber's results were confirmed. An old thermometer of Humboldt's containing 0.86 per cent of soda and 20 per cent of potash had a depression of 0.06°, while a new instrument, in which the percentages were 12.7 per cent and 10.6 per cent, respectively, had a depression of 0.65°. An English standard, with 1.5 per cent of soda, 12.3 per cent of potash, gave a depression of 0.15°, while a French "Ver Deer" instrument in which these proportions were reversed gave only 0.8°. It remained to manufacture a glass which should have a low depression and at the same time other satisfactory properties. The now well-known glass 16''' is the result. Its composition is shown in

the table. The fact that there was an appreciable difference between the scale of the 16'' glass and that of the air thermometer led to further investigation, and another glass, a borosilicate, containing 12 per cent of boron, was the consequence. This glass has a still smaller depression. As a result of this work Germany can now claim that "the manufacture of thermometers has reached in Germany an unprecedented level and now governs the markets of the world."

Previous to 1888 Germany imported optical glass; at that date nearly all the glass required was of home manufacture. Very shortly afterwards an export trade in raw glass began, which in 1898 was worth £30,000 per annum, while the value of optical instruments, such as telescopes, field glasses, and the like, exported that year was over £250,000. Such are the results of the application of science—i. e., organized common sense—to a great industry. The National Physical Laboratory aims at doing the like for England.

The question of standardization of patterns and designs is probably too large a one to go into on the present occasion. Some months ago a most interesting discussion of the subject took place at the Institution of Electrical Engineers. To my mind there is no doubt that the judicious adoption of standard types combined with readiness to scrap old patterns, so soon as a real advance or improvement is made, is necessary for progress. One who has been over some good German workshop or has contrasted a first-class English shop where this is the practice with an old-fashioned establishment where standardization is hardly known, can have no hesitation on this question. It has its disadvantages, less is left to the originality of the workman and in consequence they lose the power of adaptation to new circumstances and conditions. The English mechanic is, I believe, greatly superior to the German, but the scientific organization of the German shops enables them to compete successfully with the English.

In 1881 the German Association of Mechanics and Opticians was formed, having for its aim the scientific, technical, and commercial development of instrument making. The society has its official organ, the *Zeitschrift für Instrumentenkunde*, edited by one of the staff of the Reichsanstalt. Specialized schools for the training of young mechanics in the scientific side of their calling have been formed and now the majority of the leading firms retain in their permanent service one or more trained mathematicians or physicists. In this way, again, the importance of science to industry is recognized. I have thus noted very briefly some of the ways in which science has become identified with trade in Germany, and have indicated some of the investigations by which the staff of the Reichsanstalt and others have advanced manufactures and commerce.

Let us turn now to the other side, to some of the problems which remain unsolved, to the work which our laboratory is to do and by





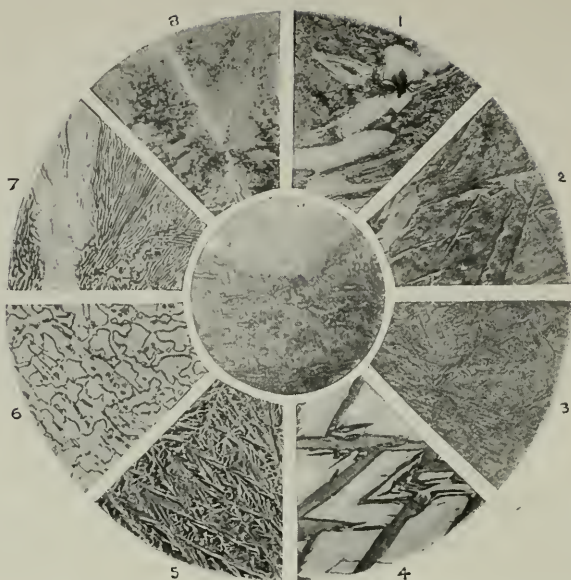

FIG. 1.—SECTION OF IRON AFTER VARIOUS TREATMENTS.

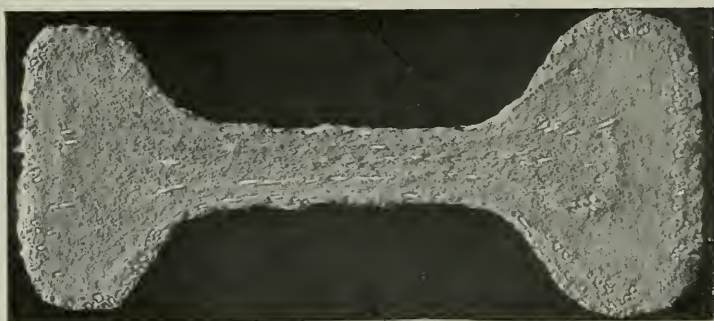

FIG. 2.—SECTION OF BAD RAIL.

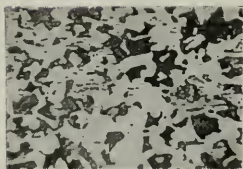

FIG. 3.—SECTION OF GOOD RAIL.

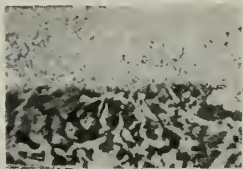

FIG. 4.—SECTION OF BAD RAIL, SHOWING SURFACE TO WHICH FRACTURE WAS DUE.



FIG. 5.—SECTION OF RAIL AFTER ROLLING.

doing which it will realize the aims of its founders. The microscopic examination of metals was begun by Sorby in 1864. Since that date many distinguished experimenters, Andrews, Arnold, Ewing, Martens, Osmond, Roberts-Austen, Stead, and others have added much to our knowledge. I am indebted to Sir W. Roberts-Austen for the slides which I am about to show you to illustrate some of the points arrived at. Professor Ewing, a year ago, laid before the Royal Institution the results of the experiment of Mr. Rosenhain and himself. This microscopic work has revealed to us the fact that steel must be regarded as a crystallized igneous rock. Moreover, it is capable at temperatures far below its melting point of altering its structure completely, and its mechanical and magnetic properties are intimately related to its structure. The chemical constitution of the steel may be unaltered, the amounts of carbon, silicon, manganese, etc., in the different forms remain the same, but the structure changes, and with it the properties of the steel. Figure 1 on Plate II represents sections of the same steel polished and etched after various treatments. <sup>a</sup>

The steel is a highly carbonized form, containing 1.5 per cent of carbon. If it be cooled down from the liquid state, the temperature being read by the deflexion of a galvanometer needle in circuit with a thermopile, the galvanometer shows a slowly falling temperature till we reach  $1,380^{\circ}$  C., when solidification takes place. The changes which now go on take place in solid metal. After a time the temperature again falls until we reach  $680^{\circ}$ , when there is an evolution of heat; had the steel been free from carbon there would have been evolution of heat at  $895^{\circ}$  and again at  $766^{\circ}$ . Now throughout the cooling molecular changes are going on in the steel. By quenching the steel suddenly at any given temperature we can check the change and examine microscopically the structure of the steel at the temperature at which it was checked.

In the figure (Plate II), with the exception of specimen No. 6, the metal has not been heated above  $1,050^{\circ}$ , over  $300^{\circ}$  below its melting point.

<sup>a</sup> Specimen.

1. Raised to  $1000^{\circ}$ . Worked and cooled slowly. Masses of carbide ground work, bands of iron and carbide, pearlite structure.
2. Raised to  $850^{\circ}$  and quickly cooled. Masses disappear.
3. Raised to  $850^{\circ}$  and quenched in water. Arcicular structure. Martensite, hard steel.
4. Raised to  $1,050^{\circ}$  and quenched in iced brine. Martensite and Austenite.
5. Same cooled in liquid air to  $-243^{\circ}$ . Much like martensite.
6. Heated to near melting point, quenched suddenly burnt steel.
7. Heated to  $650^{\circ}$ —annealed for a long time at this temperature and slowly cooled, bands of carbide and pearlite.
8. Any specimen except 6 heated to  $850^{\circ}$ , worked and slowly cooled, giving us the structure 1.

Very marked changes might have been produced in 3 by annealing at  $140^{\circ}$ .

At temperatures between about  $900^{\circ}$  and  $1,100^{\circ}$  the carbon exists in the form of carbide of iron dissolved in the iron, at a temperature of  $890^{\circ}$  the iron which can exist in different forms as an allotropic substance passes from the  $\gamma$  form to the  $\beta$  form, and in this form can not dissolve more than 0.9 per cent of carbon as carbide. Thus at this temperature a large proportion of the carbon passes out of the solution. At  $680^{\circ}$  the remainder of the carbide falls out of the solution as lamina.

Thus the following temperatures must be noted:  $1,380^{\circ}$ , melting point;  $1,050^{\circ}$ , highest point reached by specimen;  $890^{\circ}$ , 0.6 per cent of carbon deposited;  $680^{\circ}$ , rest of carbide deposited.

To turn now to the details of the photo, the center piece is the cemented steel as it comes from the furnace after the usual treatment.

These slides are sufficient to call attention to the changes which occur in solid iron, changes whose importance is now beginning to be realized. On viewing them it is a natural question to ask how all the other properties of iron are related to its structure; can we by special treatment produce a steel more suited to the shipbuilder, the railway engineer, or the dynamo maker than any he now possesses?

These marked effects are connected with variations in the condition of the carbon in the iron; can equally or possibly more marked changes be produced by the introduction of some other elements? Guillaume's nickel steel with its small coefficient of expansion appears to have a future for many purposes; can it by some modification be made still more useful to the engineer?

We owe much to the work of the alloys research committee of the Institution of Mechanical Engineers. Their distinguished chairman takes the view that the work of that committee has only begun and that there is scope for research for a long time to come at the National Physical Laboratory, and the executive committee have accepted this view by naming as one of the first subjects to be investigated the connection between the magnetic quality and the physical, chemical, and electrical properties of iron and its alloys with a view specially to the determination of the conditions for low hysteresis and nonaging properties.

At any rate we may trust that the condition of affairs mentioned by Mr. Hadfield in his evidence before Lord Rayleigh's commission, which led a user of English steel to specify that before the steel could be accepted it must be stamped at the Reichsanstalt, will no longer exist.

The subject of wind pressure again is one which has occupied the committee's attention to some extent.

The Board of Trade rules require for bridges and similar structures (1) that a maximum pressure of 56 pounds per square foot be provided for, (2) that the effective surface on which the wind acts should

be assumed as from once to twice the area of the front surface according to the extent of the openings in the lattice girders, (3) that a factor of safety of 4 for the iron work and of 2 for the whole bridge overturning be assumed. These recommendations were not based on any special experiments. The question had been investigated in part by the late Sir Wm. Siemens.

During the construction of the Forth Bridge Sir B. Baker conducted a series of observations.

Table II.

Revolving gauge, mean pressure.		Small fixed gauge.		Large fixed gauge.	
		Easterly.	Westerly.	Easterly.	Westerly.
W.	W.	W.	W.	W.	W.
0 to 5	3.09	3.47	2.92	2.04	1.9
5 to 10	7.58	4.8	7.7	3.54	1.75
10 to 15	12.4	6.27	13.2	4.55	8.26
15 to 20	17.06	7.4	17.9	5.5	12.66
20 to 25	21.0	12.25	22.75	8.6	19
25 to 30	27.0	-----	28.5	-----	18.25
30 to 35	32.5	-----	38.5	-----	21.5
Above 65	-----	-----	41.0	-----	35.25
(One observation only above 32.5).					

The results of the first two years' observations are shown in Table II, taken from a paper read at the British Association in 1884. Three gauges were used. In No. 1 the surface on which the wind acted was about  $1\frac{1}{2}$  square feet in area; it was swiveled so as always to be at right angles to the wind. In No. 2 the area of surface acted on was of the same size, but was fixed with its plane north and south. No. 3 was also fixed in the same direction, but it had 200 times the area, its surface being 300 square feet.

In preparing the table the mean of all the readings of the revolving gauge between 0 and 5, 5 and 10, etc., pounds per square foot have been taken and the mean of the corresponding readings of the small fixed gauge and the large fixed gauge set opposite, these being arranged for easterly and westerly winds.

Two points are to be noticed: (1) There is only one reading of over 32.5 pounds registered, and this it is practically certain is due to faulty action in the gauge. Sir B. Baker has kindly shown me some further records with a small gauge.

According to these, pressures of over 50 pounds have been registered on three occasions since 1886. On two other occasions the pressures as registered reached from 40 to 50 pounds per square foot. But the table, it will be seen, enables us to compare the pressure on a small area with the average pressure on a large area, and it is clear that in all cases the pressure per square foot as given by the large area is much less than that deduced from the simultaneous observations on the small area.

The large gauge became unsafe in 1896 and was removed, but the observations for the previous ten years entirely confirm this result, the importance of which is obvious. The same result may be deduced from the Tower Bridge observations. Power is required to raise the great bascules, and the power needed depends on the direction of the wind. From observations on the power some estimate of the average wind pressure on the surface may be obtained, and this is found to be less than the pressure registered by the small wind gauges.

Nor is the result surprising when the matter is looked at as an hydrodynamical problem—the wind blows in gusts—the lines of flow near a small obstacle will differ from those near a large one; the distribution of pressure over the large area will not be uniform. Sir W. Siemens is said to have found places of negative pressure near such an obstacle. As Sir J. Wolfe Barry has pointed out, if the average of 56 pounds to the square foot is excessive, then the cost and difficulty of erection of large engineering works is being unnecessarily increased. Here is a problem well worthy of attention and about which but little is known. The same, too, may be said about the second of the Board of Trade rules. What is the effective surface over which the pressure is exerted on a bridge? On this again our information is but scanty. Sir B. Baker's experiments for the Forth Bridge led him to adopt as his rule double the plane surface exposed to the wind and deduct 50 per cent in the case of tubes. On this point, again, further experiments are needed.

To turn from engineering to physics. In metrology as in many other branches of science difficulties connected with the measurement of temperature are of the first importance.

I was asked some little time since to state to a very high order of exactness the relation between the yard and the meter. I could not give the number of figures required. The meter is defined at the freezing point of water, the yard at a temperature of  $62^{\circ}$  F. When a yard and a meter scale are compared they are usually at about the same temperature; the difficulty of the comparison is enormously increased if there be a temperature difference of  $30^{\circ}$  F. between the two scales. Hence we require to know the temperature coefficients of the two standards. But that of the standard yard is not known; it is doubtful, I believe, if the composition of the alloy of which it is made is known, and in consequence Mr. Chaney has mentioned the determination of coefficients of expansion as one of the investigations which it is desirable that the Laboratory should undertake.

Or, again, take thermometry. The standard scale of temperature is that of the hydrogen thermometer; the scale in practical use in England is the mercury in flint-glass scale of the Kew standard thermometers. It is obvious that it is of importance to science that the difference between the scales should be known, and various attempts have been made to compare them.

But the results of no two series of observations which have been made agree satisfactorily. The variations arise probably in great measure from the fact that the English glass thermometer as ordinarily made and used is incapable of the accuracy now demanded for scientific investigation. The temporary depression of the freezing point already alluded to in discussing the Jena glass is too large; it may amount to three to four tenths of a degree when the thermometer is raised  $100^{\circ}$ . Thus the results of any given comparison depend too much on the immediate past history of the thermometer employed, and it is almost hopeless to construct a table accurate, say, to 0.01, which will give the difference between the Kew standard and the hydrogen scale, and so enable the results of former works in which English thermometers were used to be expressed in standard degrees.

*Values of corrections to the English glass-thermometer scale to give temperatures on the gas-thermometer scale found by various observers.*

Temp.	Rowland. °	Guillaume. °	Wiebe. °
0	0	0	0
10	— .03	— .009	+ .03
20	— .05	— .009	+ .00
30	— .06	— .002	+ .02
40	— .07	+ .007	+ .09
50	— .07	+ .016	+ .14
60	— .06	+ .014	
70	— .04	+ .028	
80	— .02	+ .026	
90	— .01	+ .017	
100	0	0	

This is illustrated by giving the differences as found (1) by Rowland, (2) by Guillaume, (3) by Wiebe, between a Kew thermometer and the air thermometer. It is clearly important to establish in England a mercury scale of temperatures which shall be comparable with the hydrogen scale, and it is desirable to determine, as nearly as may be, the relation between this and the existing Kew scale.

I am glad to say that in this endeavor we have secured the valuable cooperation of Mr. Powell, of the Whitefriars works, and that the first specimens of glass he has submitted to us bid fair to compare well with the 16'''. Another branch of thermometry at which there is much to do is the measurement of high temperature. Professor Callendar has explained here the principles of the resistance thermometer, due first to Sir W. Siemens. Sir W. C. Roberts-Austen has shown how the thermopile of Le Chatellier may be used for the measurement of high temperatures. There is a great work left for the man who can introduce these or similar instruments to the manufactory and the forge, or who can improve them in such a manner as to render their uses more simple and more sure; besides, at temperatures much over  $1,000^{\circ}$  C. the glaze on the porcelain tube of the

pyrometer gives way, the furnace gases get into the wire and are absorbed, and the indications become untrustworthy. We hope it may be possible to utilize the silica tubes, shown here by Mr. Shenstone a short time since, in a manner which will help us to overcome some of these difficulties. Here is another subject of investigation for which there is ample scope.

So far we have discussed new work, but there is much to be done in extending a class of work which has gone on quietly and without much show for many years at the Kew Observatory.

Thermometers and barometers, wind gauges and other meteorological apparatus, watches and chronometers, and many other instruments are tested there in great numbers, and the value of the work is undoubted. The competition among the best makers for the first place, the best watch of the year, is most striking, and affords ample testimony to the importance of the work. Work of this class we propose to extend.

Thus, there is no place where pressure gauges or steam indicators can be tested. It is intended to take up this work, and for this purpose a mercury-pressure column is being erected. Bushy House, from basement to eaves, is about 55 feet in height. We hope to have a column of about 50 feet in height, giving a pressure of about 20 atmospheres; it is too little, but it is all we can do with our present building. The necessary pumps are being fitted to give the pressure, and we shall have a lift set up along the column so that the observer can easily read the height of the mercury.

This column will serve to graduate our standard gauges up to 20 atmospheres; above that we may for the present have recourse to some multiplying device. A very beautiful one is used at the Reichsanstalt and by Messrs Schaffer and Budenberg, but we are told we must improve on this.

Again, there are the ordinary gauges in use in nearly every engineering shop. These in the first instance have probably come from Whitworth's, or nowadays, I fear, from Messrs. Pratt & Whitney or Brown & Sharp, of America. They were probably very accurate when new, but they wear, and it is only in comparatively few large shops that means exist for measuring the error and for determining whether the gauge ought to be rejected or not.

Hence arise difficulties of all kinds. Standardization of work is impossible. The new screw sent out to South Africa to replace one damaged in the war will not fit, and the gun is useless. A long range of steam piping is wanted; the best angle pieces and unions are made by a firm whose screwing tackle differs slightly from that of the factory where the pipes were ordered. Delays and difficulties of all kinds occur which ready means for standardization would have avoided. Here is scope for work if only manufacturers will utilize the opportunities we hope to give them.



In another direction a wide field is offered in the calibration and standardization of glass measuring vessels of all kinds—flasks, burettes, pipettes, etc.—used by chemists and others. At the request of the board of agriculture we have already arranged for the standardization of the glass vessels used in the Babcock method of measuring the butter fat in milk, and in a few months many of these have passed through our hands. We are now being asked to arrange for testing the apparatus for the Gerber & Lefman-Beam methods, and this we have promised to do when we are settled at Bushy. Telescopes, opera glasses, sextants, and other optical appliances are already tested at Kew, but this work can and will be extended. Photographic lenses are now examined by eye; a photographic test will be added, and I trust the whole may be made more useful to photographers.

I look to the cooperation of the Optical Society to advise how we may be of service to them in testing spectacles, microscope lenses, and the like.

The magnetic testing of specimens of iron and steel again offers a fertile field for inquiry.

If more subjects are needed it is sufficient to turn over the pages of the evidence given before Lord Rayleigh's commission or to look to the reports which have been prepared by various bodies of experts for the executive committee.

In electrical matters there are questions relating to the fundamental units on which, in Mr. Trotter's opinion, we may help the officials of the board of trade—standards of capacity are wanted; those belonging to the British Association will be deposited at the laboratory; standards of electromagnetic induction are desirable; questions continually arise with regard to new forms of cells other than the standard Clark cell, and in a host of other ways work could be found. Tests on insulation resistance were mentioned by Professor Ayrton, who gave the result of his own experience. He had asked for wire having a certain standard of insulation resistance. One specimen was eight times as good as the specification; another had only one one-hundred-thousandth of the required insulation; a third had about one three-hundredth.

Mr. Appleyard again gave some interesting examples, the examination of alloys for use for resistance measurements and other purposes, the testing of various insulating materials, and the like.

I have gone almost too much into detail. It has been my wish to state in general terms the aims of the laboratory, to make the advance of physical science more readily available for the needs of the nation, and then to illustrate the way in which it is intended to attain those aims. I trust I may have shown that the National Physical Laboratory is an institution which may deservedly claim the cordial support of all who are interested in real progress.



## EMIGRANT DIAMONDS IN AMERICA.\*

---

By Prof. WILLIAM HERBERT HOBBS.

---

To discover the origin of the diamond in nature we must seek it in its ancestral home, where the rocky matrix gave it birth in the form characteristic of its species. In prosecuting our search we should very soon discover that, in common with other gem minerals, the diamond has been a great wanderer, for it is usually found far from its original home. The disintegrating forces of the atmosphere, by acting upon the rocky material in which the stones were imbedded, have loosed them from their natural setting, to be caught up by the streams, sorted from their disintegrated matrix, and transported far from the parent rock, to be at last set down upon some gravelly bed over which the force of the current is weakened. The mines of Brazil and the Urals, of India, Borneo, and the "river diggings" of South Africa either have been or are now in deposits of this character.

The "dry diggings" of the Kimberly district, in South Africa, afford the unique locality in which the diamond has thus far been found in its original home, and all our knowledge of the genesis of the mineral has been derived from study of this locality. The mines are located in "pans," in which is found the "blue ground" now recognized as the disintegrated matrix of the diamond. These "pans" are known to be the "pipes," or "necks," of former volcanoes, now deeply dissected by the forces of the atmosphere—in fact, worn down if not to their roots, at least to their stumps. These remnants of the "pipes," through which the lava reached the surface, are surrounded in part by a black shale containing a large percentage of carbon, and this is believed to be the material out of which the diamonds have been formed. What appear to be modified fragments of the black shale inclosed within the "pipes" afford evidence that portions of the shale have been broken from the parent beds by the force of the ascending current of lava—a common enough accompaniment to volcanic action—and have been profoundly altered by the high temperature and the extreme hydrostatic pressure under which the mass must have been held. The

---

\* Reprinted from Popular Science Monthly, New York, Vol. LVI, November, 1899, by permission of D. Appleton & Co., owners of copyright.

most important feature of this alteration has been the recrystallization of the carbon of the shale into diamond.

This apparent explanation of the genesis of the diamond finds strong support in the experiments of Moissan, who obtained artificial diamond by dissolving carbon in molten iron and immersing the mass in cold water until a firm surface crust had formed. The "chilled" mass was then removed, to allow its still molten core to solidify slowly. This it does with the development of enormous pressures, because the natural expansion of the iron on passing into the solid condition is resisted by the strong shell of "chilled" metal. The isolation of the diamond was then accomplished by dissolving the iron in acid.

The prevailing form of the South African diamonds is that of a rounded crystal, with eight large and a number of minute faces—a form called by crystallographers a "modified octahedron." Their shapes would be roughly simulated by the pyramids of Egypt if they could be seen, combined with their reflected images, in a placid lake, or, better to meet the conditions of the country, in a desert mirage. It is a peculiar property of diamond crystals to have convexly rounded faces, so that the edges which separate the faces are not straight, but gently curving. Less frequently in the African mines, but commonly in some other regions, diamonds are bounded by 4, 12, 24, or even 48 faces. These must not, of course, be confused with the faces of cut stones, which are the product of the lapidary's art.

Geological conditions remarkably like those observed at the Kimberley mines have recently been discovered in Kentucky, with the difference that here the shales contain a much smaller percentage of carbon, which may be the reason that diamonds have not rewarded the diligent search that has been made for them.







Though now found in the greatest abundance in South Africa and in Brazil, diamonds were formerly obtained from India, Borneo, and from the Ural Mountains of Russia. The great stones of history have, with hardly an exception, come from India, though in recent years a number of diamond monsters have been found in South Africa. One of these, the "Excelsior," weighed 970 carats, which is in excess even of the supposed weight of the "Great Mogul."

Occasionally diamonds have come to light in other regions than those specified. The Piedmont plateau, at the southeastern base of the Appalachians, has produced, in the region between southern Virginia and Georgia, some 10 or 12 diamonds, which have varied in weight from those of 2 or 3 carats to the "Dewey" diamond, which when found weighed over 23 carats.

It is, however, in the territory about the Great Lakes that the greatest interest now centers, for in this region a very interesting problem of origin is being worked out. No less than 7 diamonds, ranging in size from less than 4 to more than 21 carats, not to men-

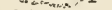

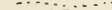
### GLACIAL MAP OF THE GREAT LAKES REGION.

- |   |   |   |
|---|---|---|
|  |  |  |
| Driftless Areas.  | Older Drift.  | Newer Drift   |
|  |  |  |
| Moraines  | Glacial Striae  | Track of Diamonds   |
|  |  | E, Eagle  |
| Diamond Localities  |   | O, Oregon   |
| K, Koltsville   |   | M, Milford  |
| O, Dowagiac   |   | P, Plum Crk.  |
|   |   | B, Burlington   |

We are indebted to the University of Chicago Press for the above illustration.  
 Reprinted by permission of D. Appleton & Co.



tion a number of smaller stones, have been recently found in the clays and gravels of this region, where their distribution was such as to indicate with a degree of approximation the location of their distant ancestral home.

In order clearly to set forth the nature of this problem and the method of its solution it will be necessary, first, to plot upon a map of the lake region the locality at which each of the stones has been found, and, further, to enter upon the same map the data which geologists have gleaned regarding the work of the great ice cap of the Glacial period. During this period, not remote as geological time is reckoned, an ice mantle covered the entire northeastern portion of our continent, and on more than one occasion it invaded for considerable distances the territory of the United States. Such a map as has been described discloses an important fact which holds the clew for the detection of the ancestral home of these diamonds. Each year is bringing with it new evidence, and we may look forward hopefully to a full solution of the problem.

In 1883 the "Eagle Stone" (Pl. II) was brought to Milwaukee and sold for the nominal sum of \$1. When it was submitted to competent examination the public learned that it was a diamond of 16 carats weight, and that it had been discovered seven years earlier in earth removed from a well opening. Two events which were calculated to arouse local interest followed directly upon the discovery of the real nature of this gem, after which it passed out of the public notice. The woman who had parted with the gem for so inadequate a compensation brought suit against the jeweler to whom she had sold it, in order to recover its value. This curious litigation, which naturally aroused a great deal of interest, was finally carried to the supreme court of the State of Wisconsin, from which a decision was handed down in favor of the defendant, on the ground that he, no less than the plaintiff, had been ignorant of the value of the gem at the time of purchasing it. The other event was the "boom" of the town of Eagle as a diamond center, which, after the finding of two other diamonds with unmistakable marks of African origin upon them, ended as suddenly as it had begun, with the effect of temporarily discrediting, in the minds of geologists, the genuineness of the original "find."

Ten years later a white diamond of a little less than 4 carats weight came to light in a collection of pebbles found in Oregon, Wis. (Pl. II), and brought to the writer for examination. The stones had been found by a farmer's lad while playing in a clay bank near his home. The investigation of the subject which was thereupon made brought out the fact that a third diamond, and this the largest of all, had been discovered at Kohlsville, in the same State, in 1883, and was still in the possession of the family on whose property it had been found.

As these stones were found in the deposits of "drift" which were left by the ice of the Glacial period, it was clear that they had been brought to their resting places by the ice itself. The map reveals the additional fact, and one of the greatest significance, that all these diamonds were found in the so-called "kettle moraine." This moraine or ridge was the dumping ground of the ice for its burden of bowlders, gravel, and clay at the time of its later invasion, and hence indicates the boundaries of the territory over which the ice mass was then extended. In view of the fact that two of the three stones found had remained in the hands of the farming population, without coming to the knowledge of the world, for periods of eleven and seven years, respectively, it seems most probable that others have been found, though not identified as diamonds, and for this reason are doubtless still to be found in many cases in association with other local "curios" on the clock shelves of country farmhouses in the vicinity of the "kettle moraine." The writer felt warranted in predicting, in 1894, that other diamonds would occasionally be brought to light in the "kettle moraine," though the great extent of this moraine left little room for hope that more than one or two would be found at any one point of it.

In the time that has since elapsed, diamonds have been found at the rate of about one a year, though not, so far as I am aware, in any case as the result of search. In Wisconsin have been found the Saukville diamond (Pl. III), a beautiful white stone of 6 carats weight, and also the Burlington stone, having a weight of a little over 2 carats (Pl. III). The former had been for more than sixteen years in the possession of the finder before he learned of its value. In Michigan has been found the Dowagiac stone of about 11 carats weight, and only very recently a diamond weighing 6 carats and of exceptionally fine "water" has come to light at Milford, near Cincinnati (Pl. III). This augmentation of the number of localities and the nearness of all to the "kettle moraines" leaves little room for doubt that the diamonds were conveyed by the ice at the time of its later invasion of the country.

Having, then, arrived at a satisfactory conclusion regarding not only the agent which conveyed the stones, but also respecting the period during which they were transported, it is pertinent to inquire by what paths they were brought to their adopted homes, and whether, if these may be definitely charted, it may not be possible to follow them in a direction the reverse of that taken by the diamonds themselves until we arrive at the point from which each diamond started upon its journey. If we succeed in this, we shall learn whether they have a common home, or whether they were formed in regions more or less widely separated. From the great rarity of diamonds in nature it would seem that the hypothesis of a common home is the more probable, and this view finds confirmation in the fact that certain marks of "consanguinity" have been observed upon the stones already found.



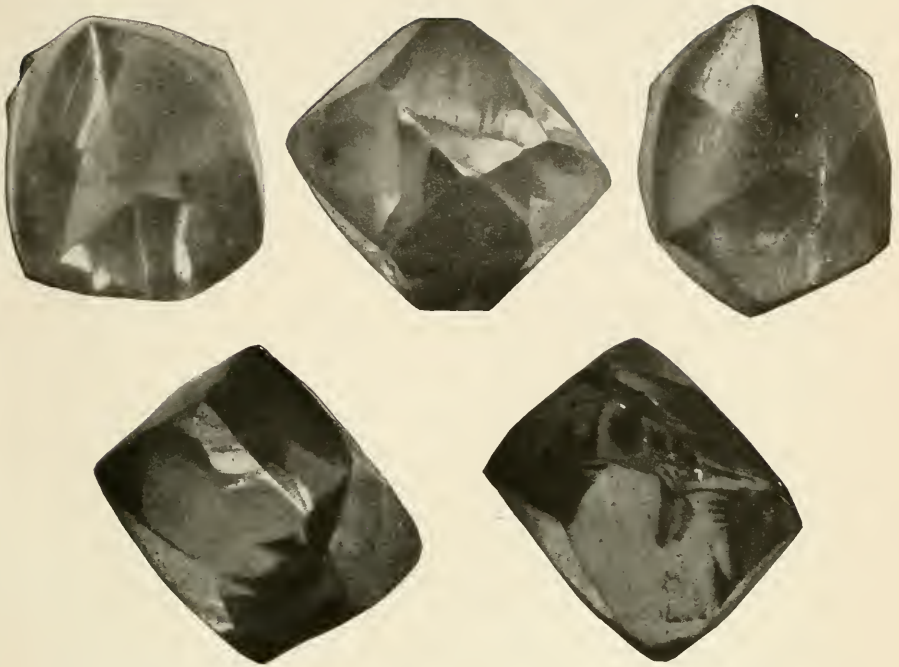

Copyright, 1899, by George F. Kunz.

FIVE VIEWS OF THE EAGLE DIAMOND (sixteen carats); enlarged about three diameters.  
(Owned by Tiffany and Company.)

We are indebted to the courtesy of Mr. G. F. Kunz, of Tiffany and Company, for the illustrations of the Oregon and Eagle diamonds. \*

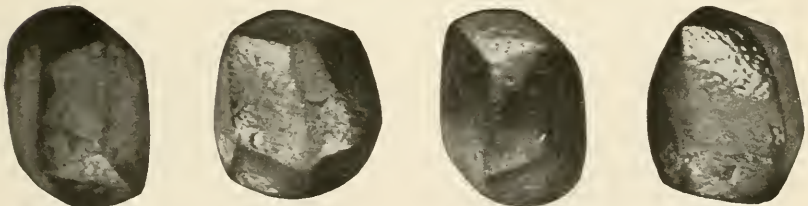

Copyright, 1899, by George F. Kunz.

FOUR VIEWS OF THE OREGON DIAMOND; enlarged about three diameters.  
(Owned by Tiffany and Company.)



Not only did the ice mantle register its advance in the great ridge of morainic material which we know as the "kettle moraine," but it has engraved upon the ledges of rock over which it has ridden, in a simple language of lines and grooves, the direction of its movement, after first having planed away the disintegrated portions of the rock to secure a smooth and lasting surface. As the same ledges have been overridden more than once, and at intervals widely separated, they are often found, palimpsestlike, with recent characters superimposed upon earlier, partly effaced, and nearly illegible ones. Many of the scattered leaves of this record have, however, been copied by geologists, and the autobiography of the ice is now read from maps which give the direction of its flow, and allow the motion of the ice as a whole, as well as that of each of its parts, to be satisfactorily studied. Recent studies by Canadian geologists have shown that one of the highest summits of the ice cap must have been located some distance west of Hudson Bay, and that another, the one which glaciated the lake region, was in Labrador, to the east of the same body of water. From these points the ice moved in spreading fans both northward toward the Arctic Ocean and southward toward the States, and always approached the margins at the moraines in a direction at right angles to their extent. Thus the rock material transported by the ice was spread out in a great fan, which constantly extended its boundaries as it advanced.

The evidence from the Oregon, Eagle, and Kohlsville stones, which were located on the moraine of the Green Bay glacier, is that their home, in case they had a common one, is between the northeastern corner of the State of Wisconsin and the eastern summit of the ice mantle—a narrow strip of country of great extent, but yet a first approximation of the greatest value. If we assume, further, that the Saukville, Burlington, and Dowagiac stones, which were found on the moraine of the Lake Michigan glacier, have the same derivation, their common home may confidently be placed as far to the northeast as the wilderness beyond the Great Lakes, since the Green Bay and Lake Michigan glaciers coalesced in that region. The small stones found at Plum Creek, Wisconsin, and the Cincinnati stone, if the locations of their discovery be taken into consideration, still further circumscribe the diamond's home territory, since the lobes of the ice mass which transported them made a complete junction with the Green Bay and Lake Michigan lobes or glaciers considerably farther to the northward than the point of union of the latter glaciers themselves.

If, therefore, it is assumed that all the stones which have been found have a common origin, the conclusion is inevitable that the ancestral home must be in the wilderness of Canada between the points where the several tracks marking their migrations converge upon one another, and the former summit of the ice sheet. The broader the

“fan” of their distribution the nearer to the latter must the point be located.

It is by no means improbable that when the barren territory about Hudson Bay is thoroughly explored a region for profitable diamond mining may be revealed, but in the meantime we may be sure that individual stones will occasionally be found in the new American homes into which they were imported long before the days of tariffs and ports of entry. Mother nature, not content with lavishing upon our favored nation the boundless treasures locked up in her mountains, has robbed the territory of our Canadian cousins of the rich soils which she has unloaded upon our lake States, and of the diamonds with which she has sowed them.

The range of the present distribution of the diamonds, while perhaps not limited exclusively to the “kettle moraine,” will, as the events have indicated, be in the main confined to it. This moraine, with its numerous subordinate ranges marking halting places in the final retreat of the ice, has now been located with sufficient accuracy by the geologists of the United States Geological Survey and others, approximately, as entered upon the accompanying map. Within the

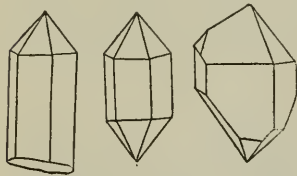

Common forms of Quartz Crystals.

territory of the United States the large number of observations of the rock scorings makes it clear that the ice of each lobe or glacier moved from the central portion toward the marginal moraines, which are here indicated by dotted bands. In the wilderness of Canada the observations have been rare, but the few data which have been gleaned are there represented by arrows pointed in the direction of ice movement.

There is every encouragement for persons who reside in or near the marginal moraines to search in them for the scattered jewels, which may be easily identified and which have a large commercial as well as scientific value.

The Wisconsin geological and natural history survey is now interesting itself in the problem of the diamonds, and has undertaken the task of disseminating information bearing on the subject to the people who reside near the “kettle moraine.” With the cooperation of a number of mineralogists who reside near this “diamond belt,” it offers to make examination of the supposed gem stones which may be collected.

The success of this undertaking will depend upon securing the cooperation of the people of the morainal belt. Wherever gravel ridges have there been opened in cuts it would be advisable to look for diamonds. Children in particular, because of their keen eyes and abundant leisure, should be encouraged to search for the clear stones.

The serious defect in this plan is that it trusts to inexperienced persons to discover the buried diamonds, which in the “rough” are prob-

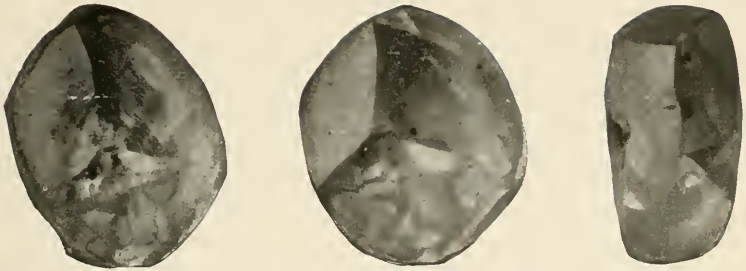

THREE VIEWS OF THE SAUKVILLE DIAMOND (six carats); enlarged about three diameters.  
(Owned by Bunde and Upmeyer, Milwaukee.)

We are indebted to the courtesy of Bunde and Upmeyer, of Milwaukee, for the illustrations showing the Burlington and Saukville diamonds.

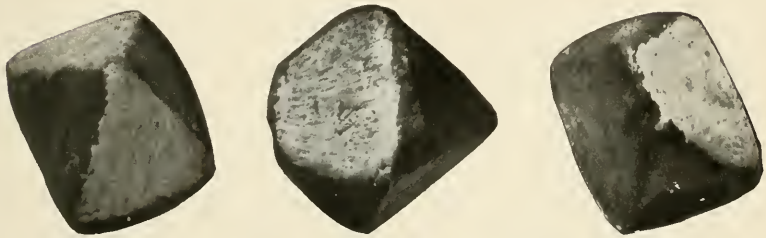

THREE VIEWS OF A LEAD CAST OF THE MILFORD STONE (six carats); enlarged about three diameters.

We are indebted to the courtesy of Prof. T. H. Norton, of the University of Cincinnati, for the above illustrations.

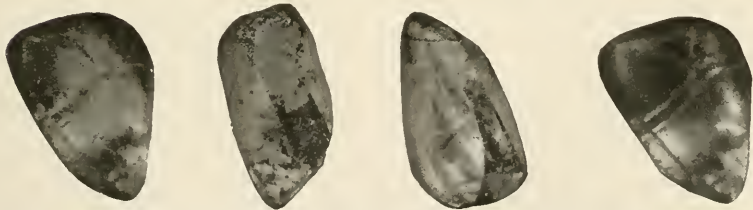

FOUR VIEWS OF THE BURLINGTON DIAMOND (a little over two carats); enlarged about three diameters. (Owned by Bunde and Upmeyer, Milwaukee.)



ably unlike anything that they have ever seen. The first result of the search has been the collection of large numbers of quartz pebbles, which are everywhere present, but which are entirely valueless. There are, however, some simple ways of distinguishing diamonds from quartz.

Diamonds never appear in thoroughly rounded forms, like ordinary pebbles, for they are too hard to be in the least degree worn by contact with their neighbors in the gravel bed. Diamonds always show, moreover, distinct forms of crystals, and these generally bear some resemblance to one of the forms figured. They are never in the least degree like crystals of quartz, which are, however, the ones most frequently confounded with them. Most of the Wisconsin diamonds have either 12 or 48 faces. Crystals of most minerals are bounded by plane surfaces—that is to say, their faces are flat; the diamond, however, is inclosed by distinctly curving surfaces.

The one property of the diamond, however, which makes it easy of determination is its extraordinary hardness—greater than that of any other mineral. Put in simple language, the hardness of a substance may be described as its power to scratch other substances when drawn across them under pressure. To compare the hardness of two substances we should draw a sharp point of one across a surface of the other under a pressure of the fingers, and note whether a permanent scratch is left. The harder substances will always scratch the softer, and if both have the same hardness they may be made to mutually scratch each other. Since diamond, sapphire, and ruby are the only minerals which are harder than emery, they are the only ones which, when drawn across a rough emery surface, will not receive a scratch. Any stone which will not take a scratch from emery is a gem stone and of sufficient interest to be referred to a competent mineralogist.

The dissemination of information regarding the lake diamonds through the region of the moraine should serve the twofold purpose of encouraging search for the buried stones and of discovering diamonds in the little collections of "lucky stones" and local curios which accumulate on the clock shelves of country farmhouses. When it is considered that three of the largest diamonds thus far found in the region remained for periods of seven, eight, and sixteen years, respectively, in the hands of the farming population, it can hardly be doubted that many other diamonds have been found and preserved as local curiosities without their real nature being discovered.

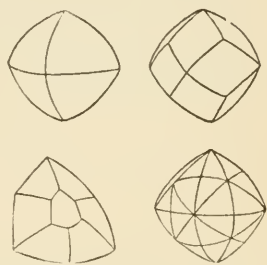

Common forms of Diamonds. The African stones most resemble the figure above at the left (octahedron). The Wisconsin stones most resemble the figure above at the right (dodecahedron).

If diamonds should be discovered in the moraines of eastern Ohio, of western Pennsylvania, or of western New York, considerable light would thereby be thrown upon the problem of locating the ancestral home. More important than this, however, is the mapping of the Canadian wilderness to the southeastward and eastward of James Bay, in order to determine the direction of ice movement within the region, so that the tracking of the stones already found may be carried nearer their home. The director of the geological survey of Canada is giving attention to this matter, and has also suggested that a study be made of the material found in association with the diamonds in the moraine, so that if possible its source may be discovered.

With the discovery of new localities of these emigrant stones and the collection of data regarding the movement of the ice over Canadian territory, it will perhaps be possible the more accurately and definitely to circumscribe their home country, and as its boundaries are drawn closer and closer to pay this popular jewel a visit in its ancestral home, there to learn what we so much desire to know regarding its genesis and its life history.



## BOGOSLOF VOLCANOES.<sup>a</sup>

By C. HART MERRIAM.

A little more than a century ago the icy waters of Bering Sea were violently disturbed, and, in a tumult of thunder, earthquake, and steam, a volcanic island was thrust up from the deep; and again, in the summer of 1883, the waters were once more convulsed, and, shrouded in steam and fog, a companion volcano was born.

The advent of the new volcano seems to have escaped observation, but the terrific disturbances attending the upheaval of Old Bogoslof were witnessed by native Aleuts and by a Russian named Kriukof, resident agent of the Russian-American Company at Unalaska, who at the time chanced to be on the nearest part of the adjacent island of Umnak.

Kriukof reported that on May 7, 1796, a storm from the northwest cut off the outlook seaward, but the following day, when the weather had cleared, a column of smoke was seen, followed by the appearance of a black object. During the night fire arose in this place, at times so bright that every object on the island could be clearly distinguished. An earthquake followed, accompanied by a terrific roaring, which seemed to come from the mountains to the south, and the rising island twice hurled stones as far as Umnak, a distance of 30 miles.

In 1806 Langsdorf passed near it at sea, and said of it: "The center point has on every side the appearance of a pillar and seems entirely perpendicular. On the northwest side are four rounded summits, which rise one above the other like steps."

The new island continued to grow, and in 1817 its circumference was estimated at  $2\frac{1}{2}$  miles, its height at 350 feet, and for 3 miles around the sea was covered with floating stones (pumice). By the Aleuts it was called *Agashágok*; by the Russians, *Joanna Bogoslova*, after St. John the Theologian.

In 1832 it was described by Tebenkof as about 1,500 feet in altitude, roughly pyramidal in form, the sides covered with sharp crags, which threatened to fall at any moment. At this date (1832) Tebenkof made

<sup>a</sup>Abstract by author of article in *Harriman Alaska Expedition*, Vol. II, pp. 291-336, October, 1901. New York: Doubleday, Page & Co. By permission of E. H. Harriman.

a rough sketch (fig. 1; originally published in Lutke's Atlas in 1836), which, so far as I have been able to ascertain, is the first published figure of the island; no others appear to have been drawn until 1873,

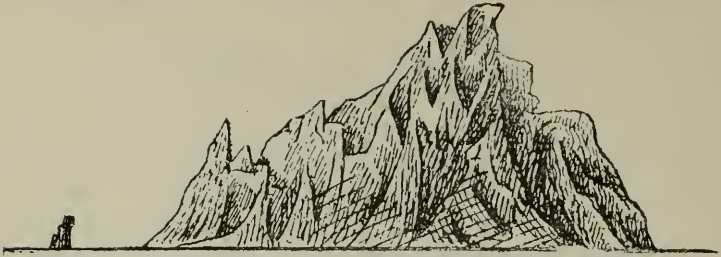

FIG. 1.—Tebenkot's sketch of Bogoslof and Ship Rock in 1832. From the south.

when Dall made six outline sketches from different positions. One of these, from essentially the same point of view as Tebenkot's, is here reproduced for comparison (fig. 2). It shows how the island had



FIG. 2.—Dall's sketch of Bogoslof and Ship Rock in 1873. From the south.

shortened, and how the elevated central peak had weathered and disintegrated until it was hardly higher than the northwest end, which end had suffered most from the inroads of the sea.

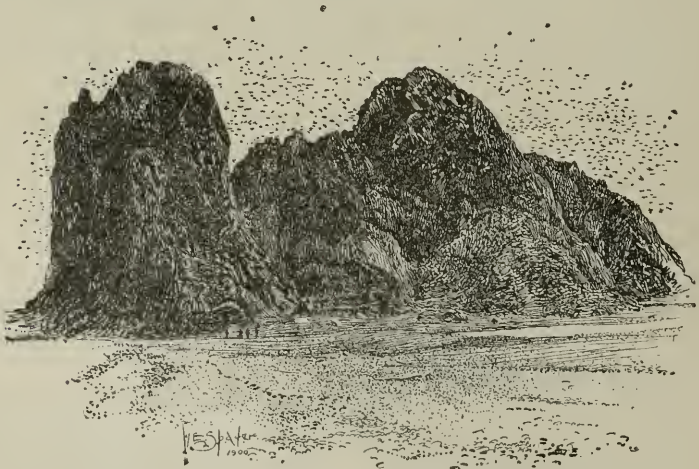

FIG. 3.—Old Bogoslof from west spit in 1891.

In 1887, according to Greenfield, the northwest peak was crowned by a slender pinnacle, which, in 1891, the date of my first visit, had fallen. In the latter year this peak was a huge, bluntly rounded pillar,



Old Bogoslof.



New Bogoslof.

BOGOSLOF AND CONNECTING SPIT IN 1884.

Photographs by Lieutenant Doty.



lower than the middle peak, and the depression between the two had become a long, deeply excavated saddle (fig. 3).

The illustrations already given show the island from the side, and give a false impression of its stability and form. When seen "end on," it appears as a narrow-crested ridge. It was described by Dall in 1873 as "a sharp, serrated ridge, about 850 feet in height, very narrow, the sides meeting above in a very acute angle, where they are broken into a number of inaccessible pinnacles" (fig. 4). This extreme narrowness has, of course, materially hastened the disintegration of the upper part of the volcano. Some idea of the loss between 1873 and 1890 may be had by comparing Dall's sketch (fig. 4) with a photograph taken by the *Albatross* in 1890 (fig. 5).



FIG. 4.—End view of Bogoslof from the southeast in 1873. After Dall.

When the Harriman expedition visited Bogoslof on the evening of July 8, 1899, fog rested so heavily on the summit that the form of the

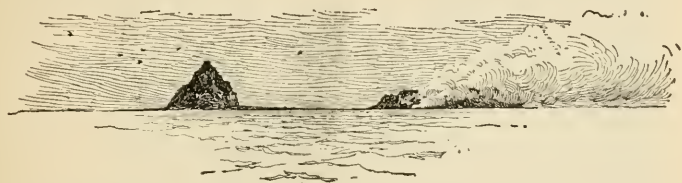

FIG. 5.—Old and New Bogoslof from the southeast in 1899. From photo by U. S. Fish Commission.

two highest peaks could not be completely made out, but the lowness of the ridge as a whole, the small size of the northwest peak, and the depth of the notch separating it from the rest of the mass, told too plainly of the rapidity with which the destruction is going on and foreshadowed the eventual downfall of the peaks.

#### NEW BOGOSLOF OR GREWINGK.<sup>a</sup>

The towering cliffs of Old Bogoslof no longer battle alone with the angry storms of Bering Sea, for close at hand a new island has risen. Its birth was not witnessed by human eye; no earthquake shock marked its advent, and the date of its upheaval may never be known. It was first seen by Captain Anderson of the schooner *Matthew Turner*, on September 27, 1883, and was then in active eruption, throwing out large masses of heated rock and great volumes of smoke, steam, and ashes, which came from the apex and from numerous fissures on the sides and base, some of which were below the surface of the sea.

<sup>a</sup>Captain Hague suggested for the new islet the name "New Bogoslof," and Dall, in an article published in *Science* in January, 1884, proposed that it be named "Grewingk," in honor of the Russian Grewingk, who, in 1850, published an important compilation of the various early accounts relating to Old Bogoslof.

Large rocks were shot high in the air, and falling back into the water sent forth steam and a hissing sound. After nightfall, the vessel being then about 25 miles to windward, fire was observed on the island. A month later (October 27) Captain Hague of the schooner *Dora* approached within a mile, passing through a streak of red water and then into a streak of green water. He is quoted as saying that black smoke, like that from burning tar, was issuing from the volcano; that it threw out flame, smoke, and red-hot rocks, and that among the sea lions observed near by were a number which had been scalded so that the hair had come off. He thinks many were killed.

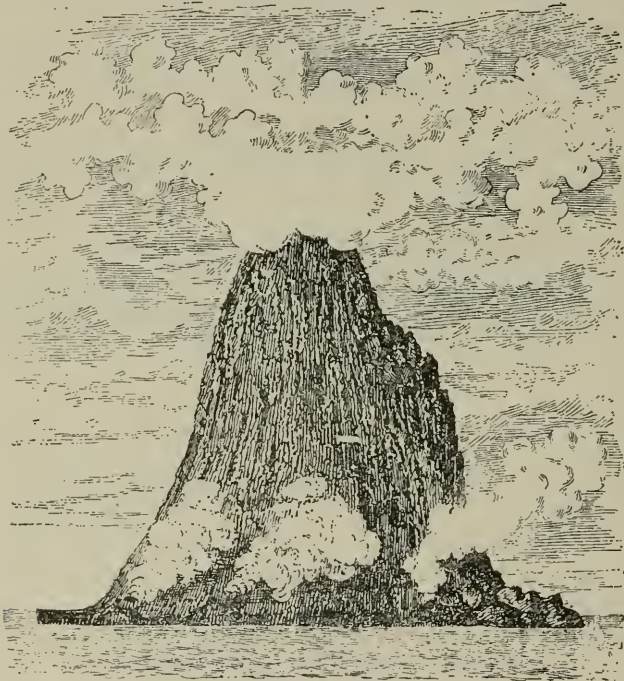

FIG. 6.—New Bogoslof in September and October 1883. Drawn by Prof. George Davidson from descriptions by Captains Anderson and Hague.

A short time afterwards both captains returned to San Francisco, where they communicated their observations to Prof. George Davidson, of the U. S. Coast Survey, who published a brief account in *Science*. They approached the island from opposite directions, passed close to it, and saw it from all sides. They agreed that the new island was larger than the old, from which it was distant about half a mile; that it rose precipitously from the sea with very steep sides; that great steam jets poured out around the base; that the summit was hidden by fog or clouds of steam, and that its height was somewhere between 800 and 1,200 feet. From their descriptions Professor Davidson made the accompanying drawing (fig. 6).



BOGOSLOF VOLCANOES, AUGUST 11, 1901.

Photograph by C. Hart Merriam.





On October 20, 1883, between the visits of Captains Anderson and Hague, a shower of fine volcanic ashes or dust fell at Unalaska, concerning which the signal observer there reported: "At 2.30 p. m. the air became suddenly darkened like night, and soon after a shower of mixed sand and water fell for about ten minutes, covering the ground with a thin layer. The windows were so covered that it was impossible to see through them." Another eyewitness stated that a remarkable black cloud appeared in the north and soon overspread the entire heavens, settling down very low and cutting off the light of the sun. It finally broke and disappeared in a shower of ashes.

The first landing on the new volcano, so far as known, was made nine months after its discovery, by the officers of the revenue steamer *Corwin*, Capt. M. A. Healy, on May 21, 1884. The report on this visit, written mainly by Lieut. J. C. Cantwell, states that the height of the new volcano was about 500 feet; that its upper third was cleft by a great fissure or crater, the interior of which could not be reached or seen, owing to the heat, steam, and fumes of sulphur; that steam issued not only from the crater, but also and with great violence from



FIG. 7.—New Bogoslof from the northwest in 1884. From Lieutenant Cantwell's sketch "A." On the right the northwest cliff of Old Bogoslof may be seen.

rents or areas in the sides of the cone; that the numerous steam vents were lined with thick deposits of sulphur, and the escaping steam was suffocating; that the volcano was covered with a thin layer of ashes, the surface of which, from the action of rain, had been converted into a crust over which the party found great difficulty in climbing, breaking through and sinking ankle-deep to knee-deep into an almost impalpable dust which rose in clouds and nearly suffocated them.

At this time the old and new volcanoes were connected by a broad bar or spit (shown in Lieutenant Doty's photograph, Pl. I, and in Cantwell's chart, Pl. III, fig. 1), from which, near the base of the new volcano, rose a tower-like rock 87 feet in height. Barnacles and water-marks on this rock, 20 feet or more above sea level, indicated recent elevation.

A week after the visit of the *Corwin* (May 21, 1884) Lieut. George M. Stoney, of the Navy, arrived at Bogoslof and spent three days in taking soundings. Many earthquake shocks were felt on the schooner as it lay at anchor, and Lieutenant Stoney states that once, when climbing the volcano, "a most sensible vibration of the whole mass

took place; rumbling sounds and a dull roar, similar to the discharge of distant cannon, were heard at intervals; and though flames were seen only upon two occasions, yet this is believed to have been due to the little darkness of the season at that latitude."

In September of the following year (1885) the *Corwin* paid another visit to the island, and on leaving in the evening witnessed a most extraordinary spectacle. The summit of the volcano was enveloped in a bright sulphurous light, which burst from long rifts in its side and shone out against the black sky in the background, a striking and impressive display.

In 1890, when seen by the *Albatross*, the islands were still connected by the gravel bar or isthmus, and their collective length was estimated at a mile and a quarter (fig. 8).

The following year, 1891, it was my good fortune to visit the volcano. Returning from the Seal Islands, which we left on the evening of August 10, on board the *Albatross*, we made direct for the volcanoes. The night was densely foggy, as usual in Bering Sea in summer, and

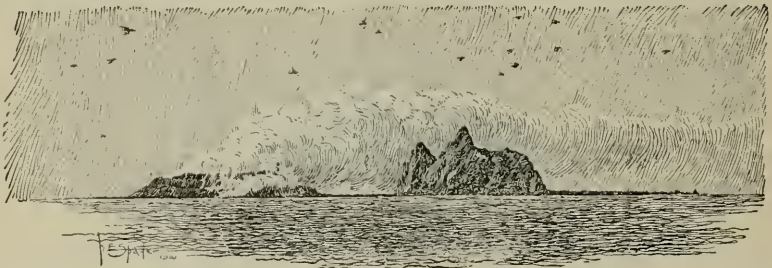

FIG. 8.—The old and new volcanoes in 1890, from the southwest (being N. 4 E.). From photograph by U. S. Fish Commission.

the early morning brought no change. The ship was feeling her way cautiously, with no land in sight, when suddenly, about 7 o'clock, the fog lifted, and we saw directly ahead, and hardly a mile away, the bold front of the new volcano. It was with a thrill of excitement that we saw the precipitous cliffs of the northern end break through the fog, and heard the fierce rush of escaping steam, whose roar, when the engines stopped, drowned all other noises, not excepting the cries of the myriads of sea birds which swarmed about the rocks like bees about a hive. A little farther away, and somewhat to the left, Old Bogoslof soon came into view. The relations of the two are shown in the accompanying reproduction of a photograph (Pl. II) taken by me from the deck of the steamer. The bar or isthmus which from 1884 to 1890 connected the two islands had disappeared. From Old Bogoslof an entirely new and very long spit had formed on the west side, and extended westerly for about a mile, leaving an open channel a quarter of a mile wide between the two islands (chart, Pl. III, fig. 2).

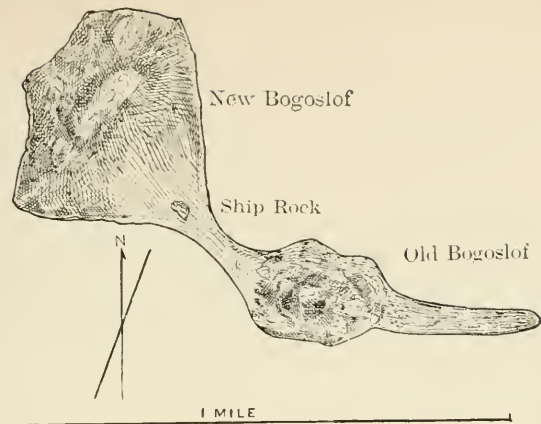

Fig. 1.—Cantwell's chart in 1884.

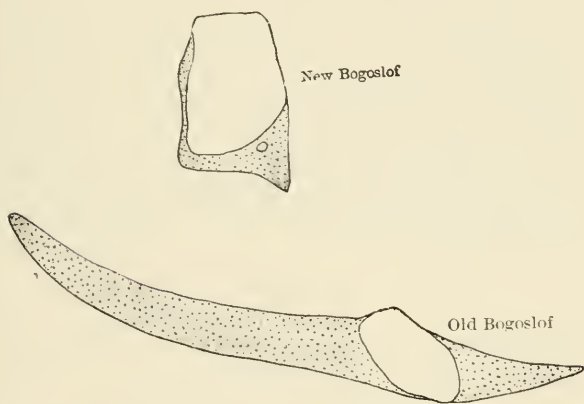

Fig. 2.—Merriam's chart in 1891.

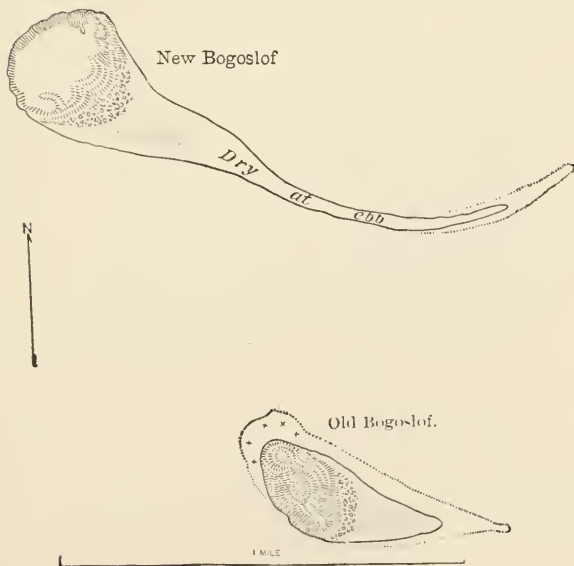

Fig. 3.—Dall's chart in 1895.

ROUGH CHARTS OF BOGOSLOF ISLANDS, SHOWING POSITIONS OF BARS IN 1884, 1891, AND 1895.



The new volcano was enveloped in steam, which issued from thousands of small cracks and crannies and poured in vast clouds from a few great fissures and crater-like openings, the principal of which



FIG. 9.—In the steam, New Bogoslof, August 11, 1891.

was near the northeast corner, only a few feet above high-water mark. From this opening, the shape of which we could not make out, the steam rushed with a loud roaring noise. In most places it

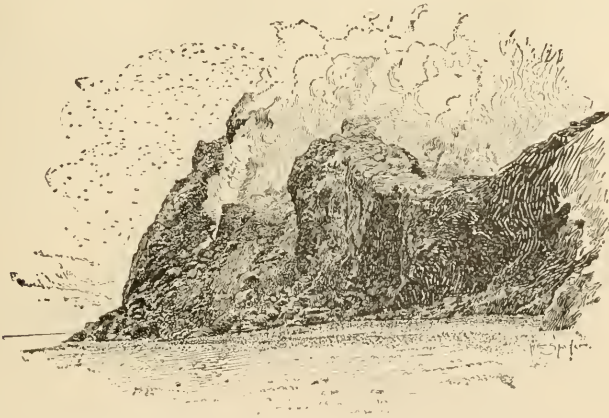

FIG. 10.—Northwest corner of New Bogoslof, August 11, 1891.

was impregnated with fumes of sulphur, and deposits of sulphur, some in very fine needles, were observed along the margins of the cracks. Most of the rocks were hot, and pools of hot water occurred along the beach.

Captain Tanner, who had been there the previous year, expressed surprise at the altered appearances. Not only had the connecting spit disappeared, but the island had decreased in height at least 100 feet, and the pinnacle had fallen and was lying in huge masses on the steep incline.

In 1895 Bogoslof was visited by Becker and Dall, of the U. S. Geological Survey. They found the activity of the steam vents greatly diminished and the top of the volcano lowered and flattened. This flattened plateau-like form has continued, and is excellently shown in

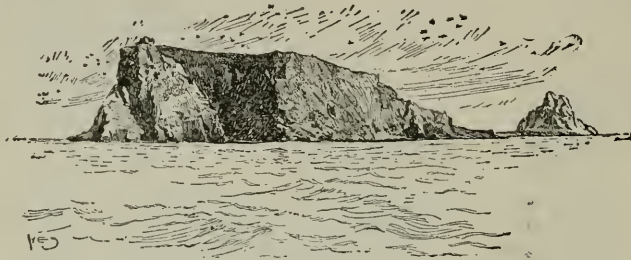

FIG. 11.—The islands from a little east of north in 1897. From photograph by Dr. L. Stejneger.

the accompanying illustration from a photograph taken by Dr. Leonhárd Stjeneger in 1897 (fig. 11).

In 1899, when seen by the Harriman expedition, no change was observed.

#### SUMMARY.

Accounts of early navigators and traditions of native Aleuts agree that long before the upheaval of the modern volcanoes a large pillar-like rock stood in the place now occupied by Bogoslof Islands. The dwindling remnant of this large rock, known as Ship Rock, whose position was between the present islands, fell in 1888 or 1889. In early times it must have been partly surrounded by low rocks or spits, for it was always a great resort of sea lions, and these animals do not remain about perpendicular rocks in the open ocean, where there is no place to land.

In 1796 a volcanic island (Old Bogoslof) was upheaved about half a mile southeast of Ship Rock. For some years it increased in size and then slowly cooled, after which it began to weather and disintegrate, and to be torn away by the sea.

In 1883 a new volcano appeared close to Ship Rock, but on the opposite (northwest) side. Its summit for the first few years was mountainous and irregular, but between 1891 and 1895 it became flattened and plateau-like.

For six years (1884-1890) Old and New Bogoslof were completely connected by a broad spit, or isthmus.

In 1891 the isthmus was washed away and a new spit a mile long formed on the west side of Old Bogoslof (fig. 12). The date of its disappearance is unknown, but in 1895 no trace of it was left.



FIG. 12.—Old Bogoslof (on left) and part of New Bogoslof (on right) August 11, 1891. Shows east and west spits of Old Bogoslof.

In 1895 a spit of about the same length reached out in an easterly direction from New Bogoslof, and in 1899 evidence of its presence was recorded.





# THE ANTARCTIC VOYAGE OF THE BELGICA DURING THE YEARS 1897, 1898, AND 1899. <sup>a</sup>

---

By HENRYK ARCTOWSKI,  
*Of the scientific staff of the expedition.*

---

The Belgian Antarctic Expedition, a member of which I had the honor to be, was the first to winter amid the ice of the South Pole—the first of the several expeditions whose combined harvest of scientific results is destined to effect a complete revolution in our knowledge of the antarctic regions. The object of the expedition was *not* to pass the extreme points reached by Ross and Weddell. We aimed, on the contrary, at achieving something new—something which might better meet the requirements of modern geography.

The expedition was a private undertaking subsidized by the Belgian Government. The initiative was due to Commander de Gerlache, who, from 1894 onward, had entertained a wish to undertake a voyage of exploration to the South Pole. Early in 1896 the Brussels Geographical Society, which gave its patronage to the project, organized a national subscription. Large and small gifts, and a generous grant from the Government, amounted to \$60,000. With this sum a whaling vessel and scientific apparatus were purchased and the expenses of the expedition paid.

The *Belgica* was a three-masted bark, 100 feet long, with a displacement of 250 tons, and auxiliary engines of 150 horsepower. The hull was protected by a casing of hard wood. Aft, on the deck, were placed the cabins of the officers and of the scientific staff, while in the fore part, under the bridge, a laboratory was rigged out.

In three essential points the organization of the expedition was defective. Firstly, there was no written contract as between the staff and the leader of the expedition, and the functions of the several members were not sufficiently defined; secondly, no written instructions were provided either by the Belgian Government or by the Geographical Society, or by any other learned body; and, thirdly, no definite programme for the voyage had been drawn up.

---

<sup>a</sup> Reprinted in abstract from the Geographical Journal, London, October, 1901. Illustrations from photographs kindly lent by Dr. F. A. Cook, a member of the expedition, by whom they were taken. The illustrations have been previously published by Frederick A. Cook, in "Through the First Antarctic Night," Doubleday & McClure Company, New York, and are copyrighted by Doctor Cook.

The Belgian Antarctic Expedition maintained, therefore, the character of a private enterprise, in which the individual liberty accorded might easily have led to anarchy on board. If I lay stress on this point, it is because I feel that the example of the *Belgica* ought not to be followed. In a similar expedition it is requisite not merely to make a good choice of the individuals who are to take part in it, but to do all in one's power from the outset to secure a proper organization, to define the duties of each one of the staff, so as to give stability to the enterprise, and, further, to provide a definite plan—just what we lacked.

We left Antwerp on August 16, 1897. The speed of the *Belgica*, under steam, being only from  $\frac{1}{2}$  to 5 knots, the crossing of the Atlantic was slow and of little interest. The vessel was so overloaded that the deck was scarcely 2 feet above the water line. Dr. Frederick A. Cook joined the expedition at Rio de Janeiro. We had several desertions among our Belgian seamen while in South American waters and finally left Punta Arenas with a quite insufficient crew. The whole complement of the *Belgica* was thus reduced to 19 men, as follows:

Adrien de Gerlache, commanding; George Lecointe, second in command, and Roald Amundsen, officer; Emile Danco, Emile Racovitza, Henryk Arctowski, and Antoni Dobrowolski, scientists; Frederick A. Cook, doctor; Henri Somers and Max van Rysselberg, engineers; Tollewsen, Melaerts, Johansen, Knutsen, Koren, Wienecke, Michotte, Dufour, Van Mirlo, seamen.

The *Belgica* left Staten Island on January 14, 1898, and it was from this date that our voyage of exploration began. We had all the equipment necessary for oceanographical investigations, and I was happy to be able at last to commence my researches, which began with an interesting discovery. South of Staten Island, in the latitude of Cape Horn, the sounding lead only touched bottom at 2,200 fathoms, and from this point the depths gradually diminish toward the south. It is, therefore, toward the east that I think we must look for the prolongation of the Andes, since south of Cape Horn we are still in the Barker basin. The Pacific Ocean ought, therefore, to be extended beyond the meridian of Cape Horn, for its natural limit will certainly be found in the submarine ridge of the Andes.

On January 23 we reached Hughes Gulf, the outlines of which are but vaguely traced on the Admiralty chart from the indications supplied early in the nineteenth century by English and American whalers. We soon saw that the modern charts of Petermann and Friederichsen, intended to illustrate the discoveries of the German Captain Dallmann, were entirely at fault. As the information respecting the lands situated to the south of Cape Horn was extremely scanty, we all worked our hardest to collect such data as should be obtainable on the nature and extent of these lands. Captain Lecointe, assisted by Commander de Gerlache, was busy from morning till night on



MIDNIGHT AND MIDSUMMER IN THE ANTARCTIC.

From "Through the First Antarctic Night." Photograph by F. A. Cook.



survey work, the *Belgica* being moved from place to place in order that all the details of the coast might be seen from near at hand; Dr. Cook was constantly at work taking photographs; Racovitza took notes on the animals and plants which he managed to collect; while I took every opportunity of landing to collect specimens of the rocks and study the glaciers of this region, besides taking numerous photographs.

I will not dwell in detail on our zigzag course through Belgica Strait. The chart constructed by Captain Lecointe gives an idea of the work accomplished during the three weeks devoted by the expedition to cartography. The important point which is brought out by Lecointe's map is that the east coast of the strait traversed by us is perfectly continuous, and that its contours display the characteristic features of a region of fiords. Toward the south this land (named by us Danco Land, in memory of Lieut. Emile Danco, who died during the course of the expedition) is connected with Graham Land, the northern extremity of which was likewise explored by us. Toward the north, on the contrary, the continental coast line was not traced by the expedition, for this would have necessitated retracing our steps, whereas, the season being already far advanced, we had to continue our onward voyage to the south. But as the inland ice rises to a very considerable height east of Hughes Inlet, I have been led to believe that land must reach in that direction as far as Louis Philippe Land. It therefore seems likely to me that the coast line is continuous to that point, and that Louis Philippe Land is in reality the northern termination of Graham Land, and that the "New Greenland" of the first explorers of this region is not a phantasm. The large islands situated to the west of Belgica Strait form an archipelago, which has been named Palmer Archipelago, in order to give a place on the maps to the name of this intrepid American navigator.

The antarctic lands which we visited are very mountainous, and the mountains reach to the shores almost everywhere. The region of Belgica Channel bears the characters of a depressed area, so much so that in spite of one's self one is driven to the conclusion that the whole block has sunk into the sea, under the pressure produced by the accumulation of ice, to a depth sufficient to restore equilibrium. By reason of this ice, which seems to be piled up in quantities almost as great as the extent of the lands permits, the relief of the ground is almost completely masked. Still there are valleys blocked by immense streams of ice, and in these valleys there must be sills, since ice falls are to be seen here and there. Cirques too occur; so that we find all the forms characteristic of fluvial erosion, and I feel no doubt at all that before the Glacial epoch this region was clear of ice, and that the traces of relief noticed were produced by running water. This relief can, however, be only guessed at, at the present day, for the eternal snows have accumulated everywhere, and it is only by the directions of the glaciers

and the external forms of the snow fields, as well as by the crevasses, that we can picture to ourselves the form of the ground on which these ice masses rest.

Still it is possible to trace some of the broad lines of the irregularities of the relief, due to tectonic causes. The two principal islands of Palmer Archipelago are traversed in the direction of their length by a chain of mountains having a well-defined direction from southwest to northeast, with, I believe, a gentle curvature to the east. The Biscoe Islands certainly form the southern prolongation of this chain, while Trinity Island is possibly that to the northeast. Moreover, from the few geological data which I could collect this line of mountains forms likewise a zone of ancient eruptive rocks, with one or more volcanoes of Tertiary, or possibly even of Recent date. Wiencke Island and the northern point of the coast of Graham Land form a similar chain, which runs in a direction parallel to the first. As regards the mountains of Danco Land, they form more important massifs of granites, metamorphic, and sedimentary rocks, while farther inland there are also some masses of gneiss, as is shown by the erratics derived from that part of the country.

I am led to believe that the more detailed study of the geology of this "New Greenland" of the first navigators will bring to light analogies between the mountain system of these lands and that of the chains which form the southern extremity of the Andes, and that we are now in a position to formulate and discuss the theory of the "Antarctic Andes." The petrographic study of the rocks which I brought back will give us some data to work from. I propose to call this system of mountains the Copernicus Range, and in this way to introduce into our geographical maps the name of the immortal Polish astronomer.

The glaciers of the antarctic lands visited by the expedition are very characteristic, and differ completely in appearance from the Alpine, or even the arctic glaciers. The line of perpetual snow running very close to the level of the sea, and in places even at that level, one of the special features of glaciers, and quite the rule in the case of Alpine and arctic glaciers, is completely absent in the antarctic glaciers. The terminal portion of the ice stream—that in which it is laid bare and melts under the influence of solar radiation and the higher temperature of the lower regions to which it has descended—which we have come to regard as quite characteristic of glaciers, is almost entirely absent. To their very extremities they are, in fact, included within the region of accumulation of snow by atmospheric precipitation. This fact alone permits the occurrence on the antarctic lands of special types of glaciers, the most remarkable of which is that of ice caps. The study of the Alpine glaciers has led geologists to distinguish only the three forms of "valley glaciers," "hanging" or "corrie glaciers,"



WIENCKE ISLAND.

From "Through the First Antarctic Night." Photograph by F. A. Cook.





and "regenerated glaciers." The idea of a glacier thus presupposes the presence of a valley. This idea is a mistaken one, for it is quite possible that the ice stream may be wanting. Such is the case in the antarctic whenever it happens that the collecting ground is sufficiently near the coast for the glacier to terminate at its greatest breadth in an ice wall. In the antarctic regions perpetual snow can exist on level ground in so low a latitude as  $65^{\circ}$ , so that even small islands may bear a complete mantle of perpetual snow. On some small islets of less than a mile in diameter we found a thick accumulation of ice entirely covering the inequalities of the ground, and forming in consequence convex glaciers. These ice caps ended seaward in perpendicular walls, while on the surface they took the form of huge, perfectly even sheep's backs.

It is evident that this form of glacier will be found also on islands of larger extent, whenever the relief is sufficiently uniform to make it impossible for a peak to pierce through the glacial cap. As regards the thickness of these caps, it is plain that it depends on the plasticity of the ice and the extent of ground on which it rests. To my mind the only difference which exists between these convex glaciers of the antarctic and the inland ice of Greenland consists in the incomparably greater extent of the latter, and in the fact that this does not reach the coast, but melts up into streamlets, and sends glaciers down toward the sea only through the valleys. But it is possible that there may be a sheet of inland ice more extensive than that of Greenland. We may say that the great ice cap supposed by Croll<sup>a</sup> may quite well cover the antarctic continent, since even small islands are seen to have the even and convex covering of ice laid down by Croll for the whole southern continent.<sup>b</sup>

On the other hand, it may seem surprising that the glacial caps are not the sole type of glacier in these regions, where the line of perpetual snow is found at sea level.<sup>c</sup> The reason is that most of the

<sup>a</sup> Climate and Time, 4th ed. (London, 1897), p. 374.

<sup>b</sup> Cf. Arctowski, "Les calottes glaciaires des régions antarctiques," *Comptes Rendus Acad. Sci. Paris*, December 24, 1900.

<sup>c</sup> The question of the level of perpetual snow in the region of Belgica Strait is a very complex one. Professor Penck, who was present at an address that I delivered at the "Naturforscher-Versammlung" at Aix-la-Chapelle, was tempted to suppose that there might well be two lines of perpetual snow, one above the other, in that region. Low-lying fogs are, in fact, very frequent there, and these protect the snow from the effects of solar radiation, while, on the other hand, the clouds which most frequently give rise to atmospheric precipitation likewise rest very low. The summits and upper portions of the flanks of the mountains (1,000 feet and over) are therefore subject to a climatic régime decidedly different from that which prevails at sea level. The mean temperature of the air is possibly lower, but, on the other hand, the amount of atmospheric precipitation is less and the effect of radiation greater. This would explain the fact that the mountain slopes are sometimes bare of snow at an altitude of 1,500 feet or even higher. It follows that the idea of two levels of perpetual snow is quite a plausible one.

islands are too high in proportion to the area occupied by the base, and that therefore the mountains can not fail to pierce through the coating of ice. The antarctic glaciers are not stationary, any more than those of other regions, and though they remain perpetually under the sway of winter, they still move on. The plasticity of the ice prevents its accumulation beyond a certain limit of height, and the mantles of ice must, even under extremely rigorous conditions of weather, be limited in thickness, while all the forms of the antarctic glaciers must be those of a semifluid mass. There are thus both ice rivers and cascades, and also forms recalling the "corrie glaciers." But all are alike buried beneath a mantle of perpetual snow, and bare ice is nowhere seen. "Inland ice," properly speaking, does not exist on the large islands of the Palmer Archipelago. On the other hand, on Danco Land and Graham Land, it is only the mountains situated near the coast which show themselves, while the whole interior of the land lying eastward is completely buried under the inland ice.

We must not, however, imagine that the antarctic lands are at the present day as heavily loaded with glaciers as they might be, for traces of a wider extension, dating doubtless from the Glacial epoch, are still preserved. The presence of these vestiges of the Glacial epoch seems to me remarkable for various reasons, and on this account I should like to bring forward some facts in support of my assertion. Gaston Islet, our eighth antarctic landing place, lying a mile from the coast, is a huge roche moutonnée, perfectly polished on the surface. At the time of our visit it was almost entirely bare of snow. Opposite this islet, at Cape Reclus, there rises along the coast a large moraine running from northeast to southwest. An examination of the map of the lands discovered by the expedition shows that the direction of the moraine is that of Belgica Strait, and we are led to the conclusion that the glacier which produced this moraine must have occupied the strait itself, which has at this point a breadth of 10 miles and a depth of 342 fathoms. Another argument is supplied by our seventeenth and eighteenth landings. On Bob Islet, not far from Wiencke Island, we discovered some well-preserved fragments of a moraine, from 15 to 20 feet high, resting against the sloping shore at a height of 80 feet above the sea. This moraine has the same direction as the channel, and its height decreases gradually toward the west. On it were some huge blocks of gneiss, perfectly polished. The red granite is in the form of rounded boulders, and the same is the case with other rocks, while the diorite is often angular.

On the other side of Belgica Strait, exactly opposite the former spot, we discovered a fine moraine on Banck Island. Its height was 65 feet, and its direction parallel to that of the strait. It rested against the sloping side of the mountain, which here displayed characteristic roches moutonnées. These moraines can only be explained as the prod-



ICE-CAPPED ISLANDS AT SOUTH END OF BELGICA STRAIT.



A TABULAR ICEBERG.

From "Through the First Antarctic Night." Photographs by F. A. Cook.







HUMMOCKS AT A PRESSURE ANGLE.



ICE FLOWERS.

From "Through the First Antarctic Night." Photographs by F. A. Cook.

uct of an immense glacier which must have flowed through Belgica Strait westward, i. e., toward the Pacific Ocean. Other proofs of the former wide extent of the antarctic glaciers are furnished by the erratics collected in Hughes Gulf, at our third, fifth, and sixth landings, as also by those found on Antwerp Island at the fourteenth landing place, where a bank of rolled pebbles and blocks extends for a certain distance from the shore. Further, in Errera Channel, a remarkable moraine runs transversely across. Lastly, we frequently saw perfectly polished roches moutonnées, either along the shore line or on small islands.

The discovery of the former greater extension of the antarctic glaciers seems to me so important a fact to record, that I could not refrain from entering into these details. The discovery is interesting from various points of view. I will here merely call attention to a question which seems to me closely bound up with it—I allude to the climate of the Glacial epoch. In fact, this question aroused a keen interest in me from the moment when I noticed the morphologic analogy which exists between the southern extremity of South America and this northern point of the antarctic continent, and which suggests the question, whether the more thorough study of the climates of the two regions and of the glaciers might not permit us to calculate the point to which the mean temperature of the air must have fallen during the Glacial epoch.

This epoch has left its mark in both regions, and the aspect presented by the antarctic lands in our day seems to afford an indication of the condition of the channels of Tierra del Fuego during the Glacial epoch. We are, therefore, justified in asking whether the existing climate of the antarctic lands in  $64^{\circ}$  may not be the same as that which prevailed in latitude  $54^{\circ}$  during the ice age.<sup>a</sup>

I am confident that the investigations of the next antarctic expeditions which may visit the two regions will furnish us with the key to the problem here indicated.

The icebergs of the arctic regions are, in general, of very varied form, and usually of small dimensions, although heights of 80 meters (260 feet) are frequently measured, and it seems that as much as 110 meters (360 feet) above sea level may be attained.<sup>b</sup> The tabular form has rarely been recorded in the arctics, although the icebergs do show it near the glaciers from which they are derived, if the slope of the glacier is slight and the berg retains its original position of equilibrium after detachment.

The antarctic, on the other hand, is the region of immense tabular icebergs. In the southern seas bergs several kilometers in length, and rising to a height of 60 meters (200 feet), have been frequently met with.

<sup>a</sup> H. Arctowski, "A propos de la question du climat de l'époque glaciaire." *Ciel et Terre*, March, 1901.

<sup>b</sup> E. V. Drygalski, *Grönland Expedition*, Vol. I, p. 381.

In the seas navigated by the *Belgica* we have seen as many as 110 icebergs at once, distributed all around the horizon. Forty per cent of these would be of the characteristic tabular form, while the remainder resembled arctic bergs, or some form derived from the tabular. Large icebergs were rare; heights of 50 meters (164 feet) were quite exceptional, and the tabular bergs averaged only 30 to 40 meters (98 to 131 feet). The tabular icebergs are covered over with nev e, and only show the alternate blue and white bands at the base. I only once had an opportunity of examining this stratification, in an iceberg which was inclosed in the pack and displaced so that the strata dipped at a considerable angle. Both the blue and white bands were formed of glacier ice with the characteristic grained structure; the strata were not sharply separated from one another, the only difference between blue and white being that the ice in the latter was more porous, inclosing a large number of air bubbles; the ice in both was compact.

The supposition that tabular bergs are formed of sea ice is entirely wrong. The mode of formation of the sea ice shows that its thickness constantly tends to a limit, supposed by Weyprecht<sup>a</sup> to be 7 meters (23 feet) at a maximum, however low the mean winter temperature and however great the number of years. I think Weyprecht's limit is too great for the antarctic regions. In any case the continental origin of the antarctic icebergs is indisputable, for the bed of the Antarctic Ocean is covered with terrigenous deposits and erratic blocks laid down by the melting of the ice, and these materials are transported to great distances from the glaciers from which they are derived.

Our soundings<sup>b</sup> and those of Ross have shown that the continental inland ice does not extend (on the continental shelf) beyond the isobath of 400 meters (1,312 feet), and this may be taken as the maximum total thickness of the icebergs coming from the pole in the whole antarctic area of the Pacific. If one-eighth of the tabular icebergs appear above the surface, we go 50 meters (164 feet) as the limiting height of the bergs detached from the great ice barrier known to extend from Victoria Land to longitude 170° W., and which doubtless continues eastward to the land to south and west of Alexander Land.

As soon as the *Belgica* entered the Pacific Ocean, the surveys of the strait discovered being completed, and the season already well advanced, de Gerlache did not wish to lose time, and set his course to the southwest in order to cross the pack which we entered in longitude 80° W. Several attempts to penetrate the pack failed.

In longitude 85°, however, the edge of the pack was more to the south, and on February 27 we reached latitude 70° S. without difficulty, the ice being navigable, and, aided by a gale, we made rapid progress

<sup>a</sup> K. Weyprecht, *Die Metamorphosen des Polareises*, p. 139.

<sup>b</sup> H. Arctowski, *The Bathymetrical Relations of the Antarctic Regions* (*Geog. Journ.*, July, 1899).





CUTTING THE CANAL FOR THE BELGICA.



COPYRIGHT 1893 BY F. A. COOK.

ICE CRYSTALS WHICH GIVE ORIGIN TO POLAR ICE.

From "Through the First Antarctic Night." Photographs by F. A. Cook.



for twenty-four hours; but the *Belgica* became altogether immovable in latitude  $71^{\circ} 30'$  S. on March 2, 1898. This latitude was never exceeded later by more than a few minutes.

No serious attempt was made to escape from our imprisonment. Wintering in the antarctic regions was part of the programme of the expedition, and it was just as well to do so where we were in the moving pack as to force a way out and return to a land station. Besides, in the explored land regions we had only seen one place where wintering was practicable—at the twelfth landing in Lemaire Channel.

Lecoq made frequent astronomical determinations of position and deduced therefrom the direction of drift. Sometimes we moved northward with southerly or southwestly winds; this we heard with joy. But with change of wind we would again go toward the pole or eastward or westward, and so we wandered from place to place, sometimes back in our old position, sometimes far to the westward. Apparently we remained immobile, for everything around us followed the same course; we always took our dreary scenery with us.

The drift of the *Belgica* with the ice is the longest experienced by any vessel: the chart shows that the movement of the pack was guided by an obstacle to the east and south of us, and the existence of land in those directions is further indicated by our soundings. Depths diminished to the south and east, and my bathymetrical chart<sup>a</sup> shows that during nearly all the time we were on a continental plateau. The pack in which we were may be regarded as a coastal pack, no doubt of great extent, but different in every respect (especially with regard to its movements) from the pack of northern polar regions. It is possible that in some years the pack becomes detached like that in the Ross Sea, but the observations of Cook and Bellingshausen, as well as our own, in 1898 and 1899, indicate that this must be exceptional. I am of opinion that the great Graham Land peninsula forms an anticyclonic region, so that, far from driving the ice toward the ocean, the prevailing northeasterly winds of the summer months send it southward; but in the Ross and Weddell seas the same anticyclonic winds produce the opposite effect, because, as they come from the southeast, they are diverted toward the north, Victoria Land being, in all likelihood, equally a region of high pressure. The forthcoming English expedition should decide this question.

The seals and penguins were our very good comrades from the beginning; they took the greatest interest in all our affairs. The penguins, particularly the small ones (*Pygoscelis Adeliae*), seemed to us remarkably intelligent, and we took great interest in watching them. They had an almost human appearance when walking across the snow, and, indeed, they had many human attributes, especially in their social customs.

<sup>a</sup>Published in the Geographical Journal, February, 1901.

On May 17 we saw the sun for the last time. In the antarctic regions, thanks doubtless to the detestable climate, the disastrous effects of the polar night are far more marked than in the north. There is a general lowering of the system, and the heart acts feebly. Several of us developed serious symptoms, and without daily care on the part of the doctor others would not have survived the period of darkness, though it was relatively short. One part of Cook's treatment was very effective and ingenious. Those who were most affected by deficient circulation were made to stand in a half-naked condition close to the red-hot stove for several hours daily. In this way the action of the solar radiation was in part replaced by rays of artificial heat—in a manner admittedly primitive—but none the less beneficial.

The sun reappeared on July 23. With its return our torpor disappeared and gave place to general activity. Lecointe, Cook, and Amundsen even risked a long expedition, taking with them provisions for fifteen days, a fur sleeping bag for three, and a tent. They stayed out for a week, but did not make much progress, for after a strong breeze several channels formed in the ice field, and they had the greatest difficulty in regaining the ship in safety. We had no kayaks, and the practical result of this little expedition was to show that without them all attempts to traverse long distances on the pack must be futile.

It was also made evident that it is impossible to go far from the floe on which an expedition is encamped without running grave risks of being unable to find a way back. For this reason I do not appreciate the opinion of a German critic, who has expressed surprise that we did not try to attain a high latitude on the pack by following a direct route to the pole. The great problem is to find the position of the ship when it is time to return to it. If we had left the *Belgica* on August 10, in latitude  $70^{\circ} 50'$  south, longitude  $86^{\circ} 30'$  west, we should have had to find her again one month later, on September 10, in latitude  $69^{\circ} 50'$  south, longitude  $82^{\circ} 40'$  west, and I greatly doubt if my German critic, even with the most favorable hypotheses, could have accomplished this tour de force.

The characteristic feature of the southern pack is the thick layer of snow which lies on it all the year round. Except for the young ice, which forms in the open channels, is broken up by every movement caused by the wind, and often presents a bare, glassy surface, the floes resemble an immense plain covered by a thick mantle of snow. The weight of this snow is so great that the ice is often depressed below the water level, and the base of the snow is transformed into blue, granular, compact ice, very different in its physical properties (composition, structure, etc.) from the ordinary ice produced by the freezing of sea water. The fallen snow is changed into névé under the influence of solar radiation and frequent changes of air temperature. In normal circumstances the field ice may be taken as about 2 meters



A GROUP OF PENGUINS.

From "Through the First Antarctic Night." Photograph by F. A. Cook.



(6½ feet), or, in the case of ice several years old, not more than 3 to 4 meters (10 to 13 feet) in thickness. The freezing action clearly tends to a limit which can not be surpassed, however low the temperature. This is the invariable result of measurements in the arctic regions, and it is entirely supported by our measurements during our wintering in the antarctic.

The greatest cold we experienced occurred in September; on the 8th the thermometer sank to  $-43^{\circ}$  C. ( $-45.4^{\circ}$  F.), an extreme temperature when one considers that we were very far from land, and only in  $71^{\circ}$  south latitude. We took advantage of the sunshine when it came, following the example of the seals, who lay motionless on the ice for hours together enjoying sun baths. When there was no wind we felt warm at a temperature of  $-15^{\circ}$  C. ( $5^{\circ}$  F.), and even  $25^{\circ}$  C. ( $-13^{\circ}$  F.), which is easy to understand, as evidently the temperature of the air did not indicate all the heat we felt, and we had only to go into the shadow to feel the difference.

In the antarctic there are strong equinoctial storms, which follow close upon one another. The storms which preceded the establishment of the summer régime were accompanied by tremendous snowdrifts, and as the *Belgica* presented an obstacle to these, large quantities of snow accumulated, and at

length almost buried her. It became necessary to extricate her, and the work had to be done quickly, as she threatened to sink gradually, dragged down by the inclosing ice.

Until December we had every confidence that the sun would melt the ice and break up the floes to such an extent that we could make our escape easily. But when December had passed, and the sun made his daily tour of the horizon without melting anything, we felt ourselves deceived; there we remained, at the mercy of fate, helpless in the middle of an ice field several miles in circumference. We attacked our floe with the explosives with which the expedition was provided, but with no effect. A careful examination of our floe fortunately revealed an old fracture, close astern of the ship, on which the ice was only from  $1\frac{1}{2}$  to 2 meters (4.9 to 6.6 feet) in thickness. Along this we cut a channel 700 meters (2,297 feet) long, and wide enough to allow the passage of the ship. The task was long and arduous, but as it was

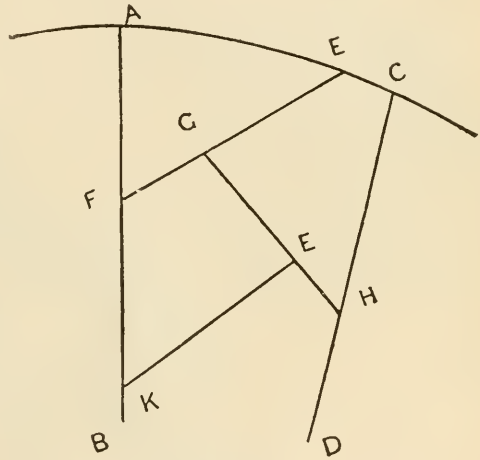

a matter of life or death to us the work went on cheerily, day and night, for a whole month. As we had only three saws we could not all work together, so we divided into two parties, one working by day, the other by night. The method we employed was very simple. Starting from the edge of our floe, A C, two lines, A B and C D, were cut, then E F, and the triangle A E F was detached and pushed out of the way. Next the line G H was cut and the quadrilateral E C H G removed; then E K, and another polygon was free. Thus we got rid of the ice piece by piece, and as each slab had to be pushed out the channel already cut was open.

The work was almost completed when a storm came upon us. The *Belgica* was nipped between two large floes, and as the swell from the ocean reached us from outside, these crushed and left the vessel alternately with every wave. We had three days of anguish, but at last the sea went down, and after some more labor, aided by a free use of our tonite, the *Belgica* was finally delivered on February 14, 1899.

We made rapid progress northward for a whole day; but then, on the edge of the pack, our way was completely barred by a number of small floes packed close together. A long month's waiting followed, tossed about all the time by the ocean swell, before we got a chance to escape to the open sea, toward which the water sky to the northward had all the time been showing us the way.

The *Belgica* left the pack on March 14, and on the 28th we were back in Punta Arenas.



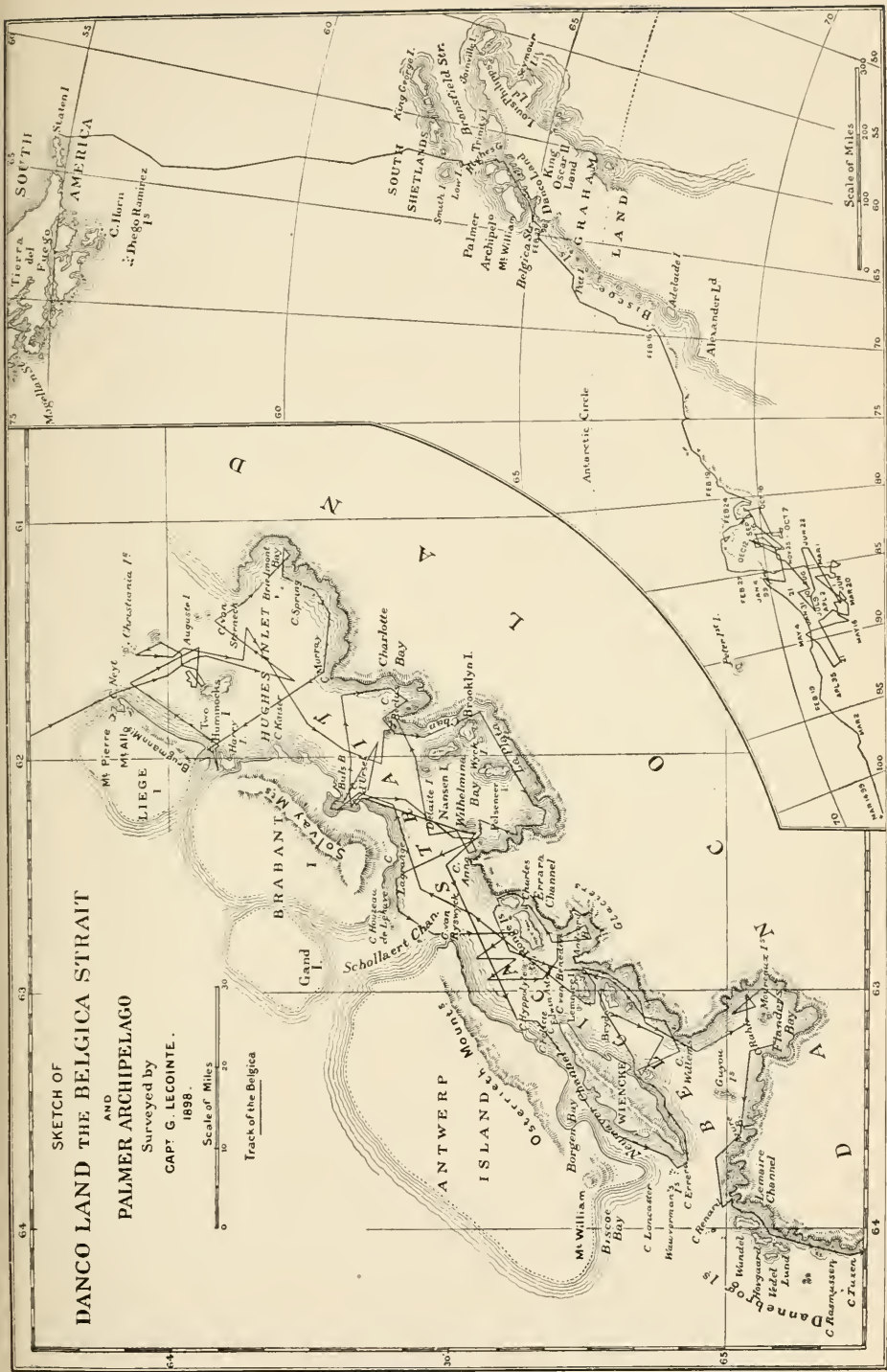

SKETCH OF  
**DANCO LAND AND THE BELGICA STRAIT**  
 AND  
**PALMER ARCHIPELAGO**  
 Surveyed by  
**CAPT. G. LECOINTE.**  
 1898.

Scale of Miles  
 0 10 20 30  
 Track of the Belgica

Scale of Miles  
 0 100 200 300  
 60 65 70 75 80



## THE SEA IN THE LIFE OF THE NATIONS.

---

By ALFRED KIRCHOFF.

[A lecture delivered at the "Institut für Meereskunde," at Berlin.\*]

---

The only absolute power on earth is the sea. The bosom of the deep brought forth land itself, whose insular fragments only here and there break the continuity of the all-embracing ocean. The sea alone constitutes a whole between the atmospheric envelope and the mineral crust of the earth, and essentially the earth is still a planet surrounded by the ocean. Again, organic life in its mysterious origins must be explained as a pregnant result produced by the sea and its movements, at the period in which there was no land, and a single unbroken ocean inclosed the terrestrial sphere as a shell, similar to the atmospheric envelope in turn inclosing the ocean. And if, indeed, evolution of life on earth follows a uniform plan, then even vegetable and animal forms on land, including man himself, are descended from marine ancestors.

However, in the course of aeons, land animals adapted themselves to conditions outside the ocean, and so a vast chasm gradually arose between creatures of the land and of the sea. Rivers and lakes, by their nature elements of the land related to the ocean, do, indeed, in exceptional instances blur the sharp boundaries confining the fauna world of the sea. Some fish, like the eel and the salmon, live in either salt or fresh water, and some sea-fish gradually accustom themselves to the water at the mouths of rivers, which is less salt than that of the open sea, and, finally, their descendants, swimming upstream, remain in fresh water permanently. The little cœlentera, for instance, in recent years passed from the North Sea, through the brackish waters at the mouth of the Elbe, into the Elbe and Saale, and even reached the fresh-water lake at Eisleben. Seals bear on land; sea-birds with great powers of flight, like the frigate-bird and the albatross, ply their mighty wings over the sea thousands of kilometers away from the coast, for days at a time. Nevertheless, in the dispersion of living creatures the coast remains the sharpest dividing line, and it is obvious

---

\* Translated from *Geographische Zeitschrift*, Leipzig, 1901, pp. 241-250.

that man, whose entire organization points to the fact that his ancestors in the Tertiary age were fruit-eating inmates of the woods, from the beginning lived exclusively on land. The coast line of the Eastern Continent may be considered the uttermost limit of the original home of primitive man.

Man could have been only affrighted by the sea when it first confronted him in all its inhospitality, with its sudden dangers threatening his fostering mother earth through high-tossing breakers, flooding tides, and fearful storms. In the face of this far-superior enemy, attacking him with elemental power, unprotected man in the first place felt himself forced into an attitude of defense, especially along flat coasts, where the rise and fall of the surface of the sea, corresponding to the incoming and outgoing tides, produced the floods that swept up far beyond the low land of the coast. Pliny has given a dramatic picture of a struggle with the ocean such as must have taken place in prehistoric times. He tells of the North Sea at the time of the Roman Empire, when the German coast was still unprotected by dikes. Every day, he says, the flood tide submerged the land of the Chauci, a German tribe. The people, who took refuge in their huts, resembled seafarers, and the setting in of the ebb tide lured them out, like castaways, to catch fish in the receding waters, or to pick up turf washed upon the damp clay ground by the flood. This example does not present the most elementary aspects of man's struggle for existence with the sea, for the means used were in a measure perfected. The Chauci had advanced so far as to provide a secure foundation for their huts by throwing up mounds, *Wurten*, such as are still used by the inhabitants of the Halligen, marshy islands off the west coast of Sleswick, which, on account of their small size, are not provided with dikes. It needed only the "golden circlet" of the dikes along the coast to secure permanently to the German mainland the belt of land once the playground of the shifting tides as a heavy marsh land rich in pastures and wheat fields. We know from history what a blessing this triumph has been to the inhabitants of the German and Netherlands coast since the Frisian tossed up his last spadeful of earth, calling out proudly to the sea, the *blanken Hans* (gleaming Hans), now held within strong bonds, *Trutz nun, blank Hans* (Do your worst now, gleaming Hans!). Since then the boast has been true: *Deus mare, Batavus litora fecit*. The success achieved over the opponent hitherto all powerful only confirmed the people in their pride of freedom. The construction of the dikes had required energetic, self-sacrificing effort of many working for a common end, and the more unremitting the necessity for united labor in order to preserve them, the harder the growth of the communal spirit behind this fortification against the tyrant Okeanos, that spirit which restrains self-seeking individualism and makes for civil order. Thousands of years before, a similar result had been effected

by the construction of dams and canals on the lower Hoangho, in Babylonia, and on the Egyptian Nile.

Incomparably more important, however, seems that decisive act of prehistoric man, when, conquering his terror of the unknown, he boldly trusted himself to the hostile element, and fared over the surging limitless waters on a fragile raft, or in a rude dugout, or in a boat of roughly joined planks. This progressive act, containing the germ of man's dominion over the earth, may have been independently executed on more than one occasion, when the various hordes, strangers to one another, into which our race had long been split by extended wanderings, arrived at the shores of the ocean. Where streams empty into the ocean, the attempt to reach the high seas might be made in river boats. Elsewhere, the impulse to move upon the sea for a longer time than swimming permits led directly to the art of building and guiding ships, the art which, in its wonderful state of development, enables man, alone among all creatures, to overstep the limits of the coast line on all sides and reach the most distant points.

But what could possibly have impelled man to this reckless venture on the ocean? Hunger, that stern and omnipotent educator of mankind, was probably a frequent motive, as may be surmised from the custom of the Chauci to hunt for fish in the ebb tide. Again, in flight before a superior hostile tribe, fear may often have made man inventive, and led him to prefer the deceptive sea as a temporary refuge to the sure fate at the hands of the enemy. If a tribe took up its permanent abode at the seacoast, two causes may have operated to educate man to gradual confidence in the once dreaded element: First, the value of the animals abounding in the waters along the coast; second, the allurements of an opposite shore. These causes may have operated separately or together. The lack of food stuffs in the polar lands would never have tempted the Eskimos to push beyond the eightieth degree of latitude. This was effected by the promise of food held out by the teeming animal life of the Arctic Sea; in fact, it was the capture of seals that led these stout-hearted inhabitants of polar lands to cross the icy American straits, and penetrate to the most northern point ever inhabited by man, making of them such unexcelled masters in the handling of kayaks that a skillful, hardy Eskimo can paddle his boat from Rügen to Copenhagen in one day. The colonization of the Hellenes progressed from the Ægean Sea, along the shores of the Black Sea, toward the course taken by the tunny in its wanderings, just as the colonization of their nautical masters, the Phœnicians, extended to various places on the shores of the Mediterranean, influenced by the presence of the shellfish from which they got their purple dye. In districts where the interior is forbidding (which is the case not only in the polar regions) through the bareness of sheer rock, the bleakness

of moorlands, and overgrown forests, and where the sea, on the other hand, with its fish, mollusks, and crabs, presents an inviting bill of fare, we find people who, like sea birds, live almost exclusively on sea food and use the land only as their dwelling place. Such are the Terra del Fuegians, who live at the extreme southern end of the inhabited earth, and the Tlinkit Indians, along the southeastern coast of Alaska, which is indented with fiords like the coast of Norway, and cut up into islands. The latter have become so accustomed to their slender, well-built boats that they use their feet unwillingly and awkwardly. Similarly, in Europe, the Danes have developed into an essentially coast-inhabiting, seafaring people, since a portion of them, under the appropriate name of Vikings (people of the fiords), established settlements between a sea teeming with fish and the bare fields of the inland. The history of the Normans unfolds an impressive picture, showing how readily the bold seaman turns sea robber. The Normans, their venturesome spirits lured by the wide freedom of the sea, soon transferred their predatory expeditions from the home soil to foreign lands. They sailed up the streams of eastern England, up the Seine and the Elbe; they harried Cologne on the Rhine, and they entered Sicily as conquerors. Of the sea the same may be said as of the desert, that rich booty entices the foolhardy to brigandage, especially when acquaintance with the lay of the land and a sure hiding place promises successful rape. The Dalmatian coast, with its concealed coves and narrow inlets, presents a number of such sally ports and loopholes for escape along one whole side of Adriatic ship routes. For this reason it was a constant seat of piracy, even in ancient times, and when Rome sent a messenger to the Illyrian queen Teuta to demand the cessation of buccaneering, her proud answer, that it did not concern Rome, that it was the custom of her people, had a certain geographical justification. Opportunity not only makes thieves, but rears a nation of robbers.

Recently doubt has been expressed, rather hypercritically, of the value of sinuses and islands as a nautical impulse to the inhabitants of coast lands. Beyond the even coast line of the Australian and the African mainland, unfringed with islands, the inhabitants have lived from the earliest days devoid of all connection with the sea. Yet no one would venture to say that the negro shows no aptitude for the seafaring life. On board our vessels many a black African has done valiant service as sailor. In fact, the whole race of Kru negroes, on the seaboard near Cape Palmas, have won world-wide fame as the best sailors employed in the West African merchant service, though, it must be confessed, that this is true only since passing European vessels have hired the "Kru boys" for the work. However, it seems significant that the one tribe of negroes that pursue navigation of their own impulse, the Papel negroes of Portuguese West Africa, south of

Senegambia, should have developed precisely at the conduit-like mouth of the Rio de Geba, opposite to which lies the Bissagos Archipelago. Along those coasts of South America that are almost entirely bereft of islands and peninsulas the European discoverers encountered nothing more advanced than rafts, with the exception of the bark canoes of the Terra del Fuegians. On the other hand, near the mouth of the Orinoco, at the point where the West Indies start out from the mainland, the Caribs were using seaworthy vessels, steered with a helm and catching the wind in cotton sails. They were dreaded pirates, and had begun the conquest of the Antilles. Again, on the west side of North America the coast assumes a fiord-like character at the strait of Juan de Fuca, precisely the point at which the Indian tribes ignorant of seacraft meet with those possessing a high degree of marine attainments. In Asia and Europe alike the acme of nautical development displays itself on the most indented edges of the continents. Among the Asiatic seafaring peoples from Arabia to Japan superiority was achieved early by those inhabiting the vastest of tropical archipelagos, which occupies the middle position in this chain of countries. Here, among the Malays, the origin of an excellent art of shipbuilding must be sought, as well as the starting point of the enormous dispersion of the Malay race over the crowded islands of the South Sea. Long before the Christian era the migration of the Malays, slowly consummated, had carried to all parts of the largest of the oceans one and the same type of rowboat—slender, sharp keeled, often provided with bowsprits as a safeguard against capsizing, and its speed increased by matting sails—a type which throughout the whole region has crowded out the awkward, barrel-form dugout. In such surroundings developed the Polynesian variety of the brown race, of all branches of the human kind, the one most intimately and most variously connected with the ocean in material and in spiritual life, even as pictured in poetry and myth. These people upon their tiny coral islands, always breathing the balmy sea air, lead an amphibious life, almost as upon ships riding at anchor on the high seas. They learn to swim earlier than to walk; as infants they are carried upon the arms of their mothers through the frothy breakers. Examining the southwestern part of Asia, the Indian and Arabian peninsulas, we realize that the never-ceasing alternation of the monsoons has been the generous promoter of traffic on the Indian Ocean. During the winter season of the northern hemisphere, the monsoon steadily drove the vessels to the east coast of Africa, and in the summer the same force carried them easily homeward to the Indian or Arabian ports. In these regions, then, earlier than elsewhere, a profitable intercourse was established across a vast ocean between two continents and widely different races. Thus it came about that the Indian bride was adorned with bracelets of African ivory, and the Indian art of

rice-growing was transported by slave dealers as far as the Kongo. Thus originated the Ki-suahili dialect, the language of the Bantu negroes intermixed with Arabic elements, and the commerce, brisk to this very day, between German East Africa and Bombay. And thus it is explained why Indian capitalists of large means have never ceased to live on the coast under German protection. Finally, what a brilliant series of nautical achievements in the course of ages is summoned before our mind's eye when we recall Greece, Italy, the Iberian Peninsula, and the Atlantic coast lands of Europe. Navigation on the Mediterranean was of earlier date, but navigation on the Atlantic attained to a higher stage of development in antiquity, because it was infinitely more dangerous to wrestle with the ocean than with the sea. Greek or Roman merchant vessels could not presume to enter the lists with the stout vessels of the Veneti, a Celtic tribe occupying what is now Brittany. They were built of solid oak planks, their anchor chains were of iron, and their sails were of leather. The journeys between Norway and Greenland, accomplished for centuries by the Normans in their great rowboats, their black-tarred "sea horses," were more valiant achievements than the passage of the Columbus caravels across the quieter southern ocean, with a compass as guide. The latter, to be sure, was fraught, historically considered, with more important results. But it was reserved for modern times and for the four countries of central location—France, the Netherlands, England, and Germany—to derive greatest benefits, in the direction of world-commerce and the establishment of colonies, from their favorable position on the shores of the most frequented of the oceans. To bring about this unprecedented rise of seamanship, it was necessary that America should first be revealed to the eyes of Europe as a stimulating goal. In the New World, again, the greatest attainments in modern naval architecture and sea traffic were reached in those parts in which endless forests supplied shipbuilders with valuable wood, and especially in those parts in which the indented coast line offered bays, inlets, sheltering ports at the mouths of rivers, and streams navigable many miles inward for moderate-sized vessels; that is to say, in Canada and the northeastern part of the United States—another evidence that a causal relation exists between the natural opportunities granted by coast lands and the nautical activities of their inhabitants.

To invest this relation with the compelling force of a natural law were inane, pseudogeographic fanaticism. Man is not an automaton, without a will of his own. The suggestions thrown out by the nature of his birthplace sometimes find him a docile, sometimes an indifferent pupil. What is now the world-harbor of New York once served the Indians as nothing but a hunting place for edible mollusks. On the same rock-bound coast that educated the Norwegians into intrepid



sailors, the Lapps are at present eking out a paltry existence as fishermen. The Anglo-Saxons, on their arrival in Britain, were so absorbed by combats with the native Celts, and later by agriculture and cattle raising, that they completely abandoned all vocations connected with the sea. Alfred the Great had to have his vessels built in German dockyards. To this day few of the inhabitants of the Cyclades take to a life upon the sea; they plant wheat, cultivate the vine, or pasture their goats. Since the Dutch have become affluent, the nautical activities energetically prosecuted by their ancestors in more straitened circumstances have fallen into neglect, and in the Belgian provinces of Flanders and Brabant, the Netherlander, more easily winning a subsistence on his fruitful soil by agriculture, industries, and domestic trade, has always been apt to resign to foreigners the very considerable sea traffic of his country.

If, however, man ventures to pit his strength against the elemental power of the sea; if he goes further and elects as his vocation the sailor's struggle with storm and seething breaker, then the poet's word in its full significance may be applied to him: "Man's stature grows with every higher aim." The mariner's trade steels muscle and nerve, it sharpens the senses, it cultivates presence of mind. With each new triumph of human cleverness over the rude force of nature it heightens the courageousness of well-considered, fearless action. Observe the weather-beaten countenances of our tars under their sou'westers, how it has become almost a habit with them to dart searching looks into the distance. Their manner is taciturn, but betrays efficiency and alertness. No sooner are their latent reserve powers challenged than the apparent sluggishness of their inactive moments is replaced by energy and amazing endurance. In those countries in which, as in Great Britain and Norway, the sea attracts votaries from extended circles of the population, and the seafarer's calling enjoys respect as a pillar of the commonwealth, the admirable traits of the seaman's character stimulate wholesome imitation even among the landmen, an effect that is heightened when the coast is but little removed from the interior, so that seacraft in all its clearly defined peculiarity is present to the minds of the people. Furthermore, if in the wake of greater intimacy with the ocean, and through it with all parts of the world, the masses come to entertain transmarine commerce and colonization schemes as familiar notions, as so often happens in the great nations that are the bearers of civilization, then the people as a whole fall heir, in large part, to the sailor's fresh, venturesome spirit; to his daring courage and his wide intellectual horizon, enlarged by contact with foreigners. A typical illustration of this truth is afforded by the contrast between the Spartans and the Athenians of ancient times—the former, brave but narrow-minded, living a conservative life, walled in by the mountains that define their

valley of the Eurotas, and further debarred from foreign traffic by the artificial obstacle of iron coin not passing current abroad; the latter, the Athenians, the Ionian race of progressive seamen, reveling in the sea breezes of the Ægean, and, their ambition overleaping the boundaries of space, full of the joyous desire of achievement.

Primitive man in all probability was barely acquainted with the ocean. For later generations it was an object of fear and terror; but when men began to inhabit the seacoast, drawing freely upon the treasures of the deep and making its broad back amenable to their pleasure in reaching distant shores, they approached it closer and closer. Yet man never succeeded in confining the sea in the fetters of slavery; on the contrary, he came to worship it as a creative deity. The entrancing beauty of the sea when in calm weather the sails glide peacefully across its mirror-like surface, genially reflecting by day the brilliance of the sun, and by night the silvery sparkle of the star-studded sky; or, when the storm whips up the waves, flaming streaks of lightning flash through the livid dullness of cloud and water, the breakers beat against the precipitous rock, and the vessel is tossed about by the tempest; and again, when, after the gale subsides, nature is once more serene, and deepening colors in many-hued play, never seen in such perfection on land, are shed harmoniously over sea and sky. All this not only inspired poetic descriptions in Homer's and Ossian's epics, it reechoes in accents true to nature, in the simple lyrics improvised by the strand folk; and the painters of all seafaring nations that have attained to distinction in art have immortalized the awe of man at first sight of the grandeur of the ocean.

Closeness to the sea has powerfully promoted science and technical skill, if only by urging both the construction of necessary vessels and steady improvement in the art of building them. To adduce the completest instance, how multifarious have been the applications of scientific principles and the demands made upon technical ingenuity since the nineteenth century created the steamboat, which enables man to cross the ocean in the face of wind and tide. The effort to make navigation as secure as possible has indirectly had a furthering influence upon a large number of the sciences. On the Caroline Islands there are still living, hoary with age, a few members of the remarkable guild in which certain astronomical knowledge valuable in steering boats was hereditary. It knew accurately the position of the fixed stars with regard to the summer and the winter horizon, and at the same time it had a more precise acquaintance with the relative situation of islands for many miles around than the geography of the civilized nations contemporary with it could boast. To Italian navigators our sea service owes the introduction of the compass, based upon the peculiarity of the magnetic needle, first noticed in China. Not only has the compass kept numberless vessels from straying out of their

course in starless nights and foggy weather, but without the huge mass of observations seamen had made in all zones, by means of the compass, a Gauss could not have grappled successfully with the problem of the magnetism of the earth. And if, hundreds of years ago, the surveyors in the Clausthal mines, consulting their compass by the light of the miner's lamp, laid out their subterranean corridors with unhesitating certainty, then, verily, this is a cultural echo of tumultuous waves dying away in the womb of mountains far removed from the sea.

But its supreme gift to man lies in the fact that the ocean alone afforded him a possibility of becoming acquainted with the globe as a whole; it unveiled the face of the earth for him. Knowledge of every part was followed by trade with every part, uniting the economies of single nations and sets of nations into a world economy. Finally, by means of universal commerce, such as only the all-embracing ocean can create, the olden separateness of the human races according to their native continents was wiped out, and the first steps were taken toward a spiritual alliance comprehending the whole of mankind. That this consummation should have been brought about primarily through world commerce is due to the not wholly evil power of the desire for gain. Nearly two thousand years ago Strabo watched seamen risk their lives on the tossing billows of the high seas while transferring wares destined for Rome from merchant vessels to lighters, because even then the Tiber was too shallow for heavy navigation, and he exclaimed, "Verily, the desire for gain overcomes all difficulties." Since time out of mind the ocean opened up to man the freeland, what is of paramount importance, the cheapest paths around the globe. From mines in the province of Sha tung we shall soon be in a position to deliver cheaper anthracite coal at Tsingtau than could be offered for sale there if brought from England. On the other hand, Milan, not to speak of the Italian coast, is too distant by the overland route for German coal to supplant English coal, because the latter can be transported by sea almost directly from the mines. Italian oranges can be bought for less in Hamburg than in Munich or Vienna, as freight by sea from Sicily to Hamburg is not so costly as freight by land, say, from Hamburg to Berlin. On account of the low freight charges, trade by sea is everywhere most lucrative. In order not to shorten the inexpensive sea route unnecessarily by a single kilometer, the great seaports have arisen in the innermost recesses of ocean sinuses. So enormous is the profit derived from world commerce by sea that it yields enough to furnish the vast sums swallowed by the construction of vessels and needed to reward the hard labor of the gallant crews who, far away from home, are exposed to constant peril, bidding defiance even to the dread typhoon.

"Unfruitful" Homer called the sea. Yet what a wealth of treasure

it showers upon man from out of its never-exhausted fund, and more still by carrying to his feet the products of the whole earth with the smallest conceivable injury to their marketable value. The countries situated on the seacoast, especially in the temperate zones, where devotion to work is at its intensest, are witness to this truth. The busiest cities, serving world commerce as seaports; the wharves; the industrial centers, desiring to have at first hand the raw material produced in foreign ports, are connected by a chain of smaller coast settlements, which likewise depend in part upon sea commerce or upon the coasting trade and the fisheries, and are usually surrounded by well-cultivated fields, fertile by reason of the mild sea breezes wafted over them. It is the more easily attained prosperity that lures men to the coast. Therefore islands, as compared with the neighboring mainland, and smaller islands—conditions on the whole being equal—as compared with larger ones, are distinguished, in consequence of their relatively greater coast allotment, by greater populousness. Wherever land and sea touch each other, there, naturally, are most apparent the blessings which the sea bestows upon mankind.

Finally, let us cast a rapid glance at the political importance of the sea. From what has been said it is obvious that every State, as soon as it realizes the advantages of sea life to its citizens, will strive to extend its territory to the sea, though it should only secure so tiny a strip of coast as Montenegro recently obtained on the Adriatic. He who has one foot planted on the coast can dispatch his vessels over the whole earth. With but a single port, to what a commanding position in sea commerce, in dominion over the sea, and in colonization as far as the most distant shores of the Black Sea, did Miletus attain in antiquity and Genoa in the Middle Ages. Switzerland, founded in the heart of Europe on the Alpine battlements, comes to mind as the only one and as a remarkable example of a State carrying on trade with the whole world by means of the vigorous industrial enterprise of its citizens, though it can never hope to acquire coast possessions. But, when disposing of her products and transporting them, how painfully Switzerland feels her dependence upon the customs regulations and the railroad rates prevailing in the four great powers encircling her. Russia, on the other hand, affords the most striking instance in history of a State purely inland in origin advancing with conscious intent, step by step, to the shores of all the seas in its surroundings and attaching them to itself until its banners wave from the Baltic to the Yellow Sea.

But the best, indeed the most indispensable, gifts of the sea to the state, as such, are these three: independence, unity, and plenitude of power. Ratzel properly points out that the sea is absolutely uninhabitable, hence constitutes the securest defense of a state. How much less guaranteed would the freedom of the greatest republic seem if

the United States had not won the Pacific in addition to the Atlantic littoral. A state with seagirt territory, like Great Britain, Japan, and now Australia, the new island state, can be assaulted only in spots, with blockading fleets. By the preponderance of her sea front, France seems better protected than Germany. In the same way friendly intercourse can penetrate only here and there, at given points, to the interior of a state limited by a coast line. Therefore, state boundaries marked by the sea are ethnically more definite than the vaguer lines on land, and in this respect superior to them. They are a better aid in promoting and maintaining the unification of mixed races into a single nation. History affords a solitary example of the reverse; the Mediterranean, surrounded by the provinces, instead of itself surrounding them, was the power that bound and kept together the elements composing the mighty world-empire of Rome. Incessantly the ocean brings unity and power from without to all states upon whose edges it breaks, and which understand its admonishing call. Greece and the Apennine Peninsula, with their mountainous interior, transfer the better part of their traffic to the coasting trade, which day by day brings inhabitants and possessions from the north into contact with those of the south, heightening the community of interests, and at the same time leading the mind constantly beyond the home shores of the high seas.

More than anything else sea trade, together with every sort of activity demanding transmarine effort, whether it be vast industrial enterprises, technical achievements on sea, or colonization, establishes an intimate connection between a nation and the great world. At the same time it welds together, in indissoluble union, the interior of the state with its coast provinces, the only paths along which lively exchange is effected with foreign parts. As with hammer blows, it brings home the realization of kinship and unites the parts into a whole. We Germans feel this more strongly now than ever. No Hohenstaufen will again turn his back indifferently upon the German coasts, to cross the Alps and lead campaigns against Rome. No Hanseatic League of to-day would have to lower its flag in displeasure for lack of imperial protection of its glorious deeds. A fleet of ironclads floating the German imperial banner, and growing day by day, guards our merchant marine on all the seas, and to the furthestmost shores within and beyond the territory under our protection it extends its sheltering arm over every honest enterprise undertaken by German citizens. Thus, defended from hostile injury, the goods of the world acquired by German industry flow over the threshold of the sea into all the provinces of our land, raising the prosperity of our people to heights never before attained, widening its spiritual horizon, and fostering the power of the state. The glory of the German Empire lies firmly anchored in the ocean.





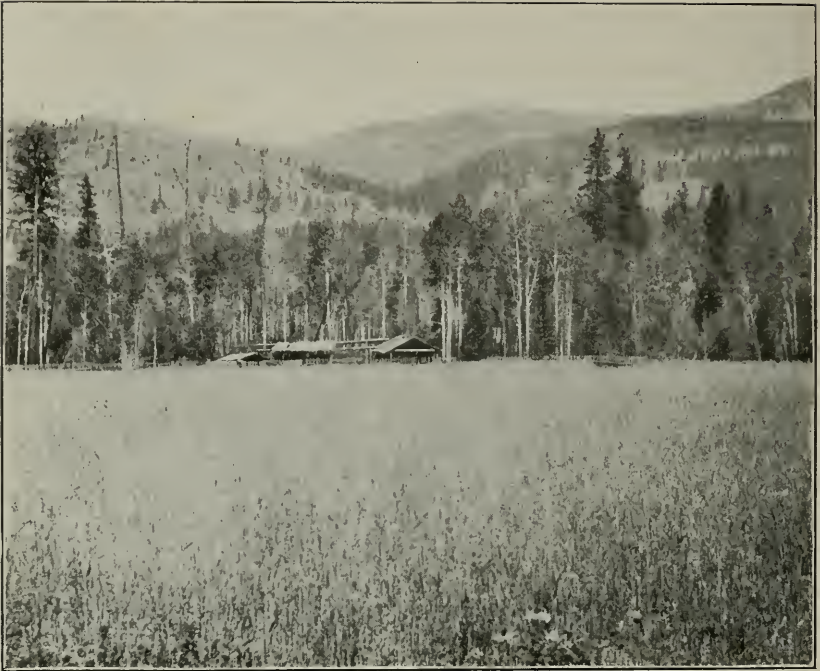

FIG. 1.—CLEARING OF WESTERN FRONTIER, WASHINGTON.



FIG. 2.—RED FIR REOCCUPYING AN ABANDONED FIELD, WASHINGTON.



## FOREST DESTRUCTION.

---

A.—NOTES ON FOREST DESTRUCTION.

By GIFFORD PINCHOT.

---

The point of view of the agricultural settler in any forest region, whether in the United States or elsewhere, is that of hostility to the timber which limits and confines his industry. To get rid of the timber with him means expansion, progress, and well-being. As settlement progresses and the forests disappear, a second phase of opinion crystallizes and becomes effective. Its center of distribution is in the towns or cities, and it is largely concerned with purely sentimental considerations. This school of thought regards the preservation of the forest as an unmixed good with the same unyielding depth of conviction which, among the early settlers, marked the opinion that its existence was an unmixed evil.

From the point of view of national progress the one opinion is as mistaken as the other. Both are likely to be survived by that phase of thought which regards forest protection as a means—not an end; which contends that every part of the land surface should be given that use under which it will contribute most to the general prosperity, and the purpose of whose action is best phrased, in the language of President Roosevelt, as “the perpetuation of forests by use.” The essential reasonableness of this point of view is gaining recognition among the adherents of both the schools of thought which preceded it, and is doing more than any other single factor to call attention to the wastefulness of forest destruction and to emphasize the essential practicability of conservative forestry.

As a broad general rule, subject to many exceptions, it may be said that the destruction of a forest on land better adapted for forestry than agriculture is not likely to be more than temporary in character. Ultimately the forest will return, but the time which must elapse between the destruction of a forest and the reappearance of the same type of forest on the same ground, however brief geologically, is often of appalling length from the human point of view.

Thus, great areas of land in New England, once cleared, are now returning, through the gradual spread of the forest in old pastures and on abandoned hillsides, to a wooded condition. The type of forest

that was destroyed may be slow in returning, even after the forest condition is established, and great length of time, in tens or hundreds of years of useful growth, may be lost; but, in the great majority of cases, the type of forest once best adapted to the land will clothe it again.

The destruction of a forest through fire or otherwise brings about two results. In the first place, it disturbs the general balance of nature, sets free geological activities which were previously held in check, and begins a long process of readjustment. In the second place, it profoundly modifies the vegetation for a longer or shorter term of years, both before and after the forest condition is restored.

The chief geological agent set at work by forest destruction is water. We are already well persuaded in general of the effect of forests on the flow of streams. Yet an illustration which I may borrow from an unpublished paper by Mr. Filibert Roth will serve to set the matter in a clear light. If an ordinary desk or table be tilted and water is sprinkled on its surface, the water speedily runs off. If the tilted table is covered with an inch or two of loose soil, the water falling upon it is at first somewhat retarded in its journey to the lower edge; but soon not only does it find its way there with rapidity, but it carries with it relatively large amounts of soil. As yet no reservoir has been established on the sloping surface. If now a layer of cotton batting, which we may liken to the mat of decaying leaves and twigs which constitutes the forest floor, be laid on the surface of the soil erosion ceases, the water which falls sinks gently into the soil, and the soil on the surface of the table has become in effect a reservoir for the temporary retention of water. Such a reservoir will continue to give out water long after the rain has ceased to fall.

Over large areas of our country, especially in the far West and in the Southern Appalachians in the East, the water-conserving property of the forest is for the present, and is likely long to continue, its most important one. In addition to the loss of water by promoting its useless waste in floods there is the loss of the soil itself. Fertile soil is the product of long geological processes and is perhaps the most valuable asset of any nation. Forest destruction tends to convert the soil of productive fields into costly and dangerous bars at the mouths of rivers and harbors, by permitting its transportation by water to the sea. The washing away of cleared soil is proceeding with astonishing rapidity in many parts of the country. The damage is most visible in the gulying of hillsides, but it is not less destructive in the removal of the surface soil without gulying, where heavy rains and smooth steep slopes make the process possible. Estimates of the loss from this source have been made, notably by Professor Shaler, of Harvard, but it is sufficient to say here that the damage is on a gigantic scale and that it is steadily increasing in the United States.



FIG. 1.—DAM FILLED WITH SILT, ARIZONA.



FIG. 2.—HOLES OF UPROOTED TREES GRADUALLY FILLING WITH SOIL AND HUMUS, WASHINGTON.







FIG. 1.—CONIFERS STARTING BENEATH POPLAR ON BURNED LAND, ADIRONDACKS.



FIG. 2.—LOGS AND QUAKING ASPEN ON BURNED LAND, COLORADO.

The forest is then the great moderator of geological action by transportation and here it renders one of its greatest services to man. Another service, indicated but not yet fully explained by observations already made, is the preparation, on land suitable for agriculture, of fertile soil for human use. The introduction of decaying vegetable matter, with the resulting liberation of carbonic-acid gas at considerable depths in the mineral soil when roots die, is one of the means. Another, far more frequent, geologically speaking, than is apt at first glance to appear, is the plowing of forest soil by the wind. This takes place when trees are overturned and their roots carry with them to the surface considerable quantities of mineral soil as yet little mixed with vegetable matter. Into the hollow from which this soil came the leaves are washed and blown. Small quantities of humus find their way in from the edges and a deposit of fertility is made a foot or two or three below the general level of the surface. When once the attention has been called to it, the frequency of the little mounds, which remain long after the tree itself has entirely rotted away, is seen to be very great. Positive information is yet lacking by which to judge of the total effect of this curious function of the forest.

The second effect of temporary forest destruction is to produce what may be called the preliminary vegetation and afterwards to modify the character of the forest itself when the latter finally returns. Take, for example, a recently burned area in the Adirondacks. The surface, if not too rocky in character, is densely occupied, within a year or two, with fire cherry, raspberries, and similar short-lived vegetation. In the shadow of these forerunners young trees start, but they are of comparatively worthless kinds. Fire cherry and poplar are usually the most common species. Short-lived, rapidly growing trees of little value in themselves, their principal use is to prepare a seed bed in which the seeds of spruce and pine, maple and birch may germinate and then pass through their delicate infancy under the protective shadow of trees which will disappear usually before their competition has become seriously dangerous, and sustained by the rich humus they have prepared. These are the wise nurses of the new forest, which retire when their charges are old and strong enough to shift for themselves. In the Rocky Mountains the lodgepole pine and the quaking aspen—the latter one of the trees called poplar or popple in the North-east—are the principal nurses of more valuable kinds. Both form pure stands of their own and both attain subordinate commercial value. The lodgepole is spreading over enormous areas through the agency of fire, and with the disappearance of fire it will gradually but inevitably lose its hold.

Not all trees require nurses when their elders have been burned or cut away. Conspicuous exceptions are the red fir of Washington and Oregon, the redwood of California, and over large stretches from

South Dakota to New Mexico and from Colorado to California, the Western yellow pine. These trees replace themselves. The loss from their destruction is to be measured in the fertility of the soil, in its water-storing power, and in amount of production measured by time.

That a manufacturing plant should remain idle is instantly recognized as a loss to any community. The forest is a manufacturing plant for the production of wood. That a forest soil should remain idle from the production of trees, or should produce but a part of the wood it is capable of making, is as clearly detrimental as for a factory to be shut down or to be occupied but half the working days.

About one-third of the total stand of forests in the State of Washington when white men came there, has, since their arrival, been destroyed by fire. A very large part of this area is still producing but a fraction of the wood which it is capable of growing. The situation of such a forest may be likened to that of a machine shop, fitted to produce shafts, cog wheels, and other mechanical devices, the owner of which, when he wanted a shaft or a wheel, should remove one from the machinery of the shop instead of using the shop to produce what he wanted. Forestry assumes and asserts that forests may be used for the production of wood without endangering or reducing their productive capacity. That this is so, and that forest destruction is a useless waste, is being rapidly understood throughout the United States. When it is not only understood, but generally acted upon, as is now being done by some of the most progressive among the lumbermen and other forest owners, the situation in forestry will be secure.

---

B.—DESTRUCTION OF THE FOREST MEANS DESTRUCTION OF THE FAUNA AND FLORA.

By C. HART MERRIAM.

---

The destruction of a forest is inevitably followed by a profound modification—amounting often to annihilation—of the forest fauna and flora. It goes without saying that when the trees are gone the birds that live in the trees, as nuthatches, creepers, woodpeckers, warblers, vireos, jays, chickadees, and the like, and tree-loving mammals, as the arboreal squirrels, opossums, raccoons, martens, and others, can no longer exist.

But a forest fauna is by no means restricted to the species that live in trees. In most forests the ground is covered and protected by bushes and small plants, which for successful growth and reproduction require both shade and moisture, and which in turn furnish food and shelter to many kinds of animals. When the forest is destroyed, particularly in regions of scanty rainfall, the undershrubs and other forms





FIG. 1.—REPRODUCTION OF PURE RED FIR ON BURNED LAND, WASHINGTON.  
Red alder in the foreground.



FIG. 2.—A FOREST WHICH HAS BEEN LUMBERED CONSERVATIVELY, ADIRONDACKS.



of lowly vegetation wither and die, and the forms of animal life dependent on the shelter thus afforded are either destroyed or driven away. It often happens that this undervegetation is swept away by fire or devoured and trampled by sheep without immediate serious injury to the trees. Persons familiar with the forests of our western mountains do not need to be told that where sheep have been allowed to graze for several years the undervegetation is destroyed and the surface of the ground converted into an absolute desert, although the trees remain. In these cases the extermination of the fauna and flora is almost as complete as if the forest itself had been consumed. In other words, the forest fauna, consisting in the main of species dependent on the protection and food afforded by the smaller plants, can not exist when these plants are removed. This is true not only of a host of insects and other lowly forms of animal life, but also of most reptiles and mammals, and many birds. Birds that nest on the ground or in logs or shrubbery, such as grouse, sparrows, thrushes, wrens, and others, are completely exterminated by fire, sheep grazing, and other agencies which destroy the undervegetation. The same is true of mammals, for the numerous kinds of mice, shrews, chipmunks, ground squirrels, wood rabbits, weasels, and others that are dependent on the undervegetation of forests disappear when this shelter is removed.

It follows that preservation of the forests implies preservation of the native flora and fauna. Hence the movement now on foot to set aside certain forest reserves as permanent game preserves is worthy of the earnest support of all who have at heart the welfare and perpetuation of our forest fauna.



## IRRIGATION.

---

By F. H. NEWELL,

*Hydrographer, U. S. Geological Survey.*

---

With the cessation of Indian wars and of daily news of frontier strife, the people of our country have come to regard the United States as settled and no longer affording opportunity for notable expansion of internal resources. It is true that the frontier of civilization has disappeared as regards the United States proper, and interest in the warfare between the white settler and the savage, or native occupant of the soil, has been transferred to outlying possessions. Civilization in its march across the Mississippi Valley to the Rocky Mountains has reached the Pacific coast (Pl. I), but in so doing took rapid strides across a third of the continent and left but few footprints on its course. Now, at the beginning of the twentieth century, when we come to take account of the progress made, we are surprised to find that one-third of the whole United States remains vacant land, still belonging to the people as a whole and at the disposal of Congress.

The question may well be asked, Why is it, with the keen desire for land ownership possessed by the American people, that this one-third of the United States should be left untouched? The soil is known to be as fertile as that of any part of the globe, and the land laws are extremely liberal, so that there is no difficulty in securing title, and farms can be had almost for the asking.

The anomalous condition exists that although one-third of the United States proper, excluding Alaska and outlying possessions, consists of vacant public land (as shown in fig. 1), yet there is no longer an outlet for the homeseeker upon these lands. In the past the vast unoccupied public domain has served as an outlet for surplus labor and has afforded scope for the energies of thousands of young, able-bodied men, who, while without financial means, have had the ambition to become landowners and to grow up with the increasing development of a new country.

After the close of the Civil War and at times of great industrial depression, when men sought an opportunity to earn their daily living

and the doors of factories and machine shops were closed, there was a steady stream of pioneers, representing the best of the bone and muscle of the country, going out upon the broad plains and prairies, building up substantial communities and expanding within our own borders the area of the highest type of civilization. All this has passed away. There are no longer to be seen the prairie schooners and the emigrant wagons filled with household goods, with the children on



FIG. 1.—Map showing location of vacant public lands. [The open or white spaces show the vacant lands.]

top or trailing behind. Only the Pike County wanderer, who is always seeking something better, is still to be found pursuing his aimless search for the promised land. It is true that the railroads have done away with the necessity for the overland journey, but the railroads cover only a very small extent of the vast inland empire of the United States. Stretches of hundreds of miles of vacant public land lie between the railroads, but across these fertile plains the homeseeker no longer travels.

*Vacant and reserved areas in the western public-land States, in acres.*

State or Territory.	Total area.	Vacant.	Per cent.	Reserved.
Arizona .....	72,268,800	48,771,000	67.5	18,285,000
California .....	99,827,200	42,049,000	42.1	16,064,000
Colorado .....	66,332,800	39,116,000	59.0	5,694,000
Idaho .....	53,945,600	42,475,000	78.7	1,747,000
Kansas .....	52,288,000	1,085,000	2.1	988,000
Montana .....	92,998,400	65,803,000	70.8	12,348,000
Nebraska .....	49,177,600	9,927,000	20.2	70,000
Nevada .....	70,233,600	61,322,000	87.3	5,983,000
New Mexico .....	78,374,400	55,589,000	70.9	6,385,000
North Dakota .....	44,924,800	16,956,000	37.7	3,370,000
Oklahoma .....	24,851,200	4,654,000	18.7	7,158,000
Oregon .....	60,518,400	33,784,000	55.8	5,500,000
South Dakota .....	49,184,000	11,869,000	24.1	12,803,000
Utah .....	52,601,600	42,516,000	80.8	5,488,000
Washington .....	42,803,200	11,913,000	27.8	10,765,000
Wyoming .....	62,448,000	47,657,000	76.3	7,995,000
Total .....	972,777,600	535,486,000	55.1	120,643,000

It is not because there is lack of land, for in the Western States and Territories there are over 500,000,000 acres still vacant, much of it having the richest soil of any in the United States. It is not because

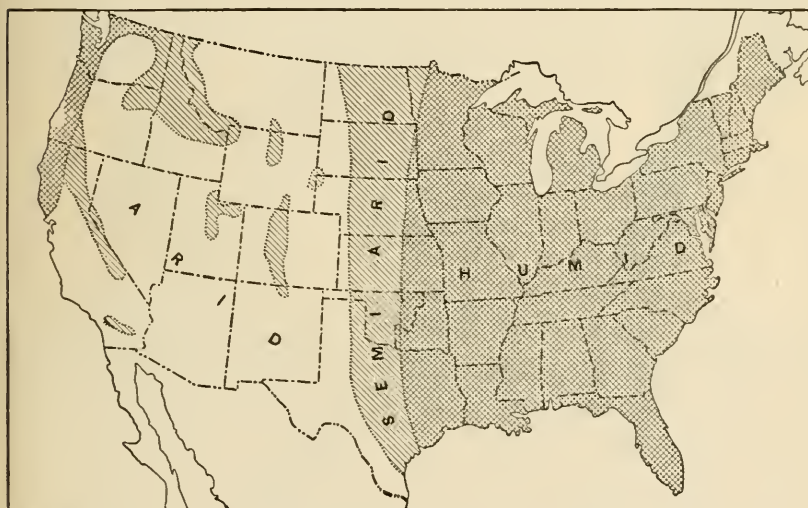

FIG. 2.—Map showing arid, semiarid, and humid regions of the United States. [Comparing this with fig. 1, it is seen that most of the arid region is vacant.]

the pioneer spirit no longer prevails, for the country is as full of adventurous spirits as ever, and it requires merely the intimation that some Indian reservation is to be opened for thousands of people to gather to make the rush or try their chance in a lottery. There is plenty of land and there are numberless people eager to occupy it. What, then, is it that prevents their doing so? Simply the lack of water. The country is dry and the ordinary farm crops can not be cultivated without an artificial application of water at certain times and seasons.

It must not be supposed that there is no water to be had. On the contrary, occasional storms occur, sending down vast quantities of water and inundating the thirsty plain. This rushes off and in a few hours the channels of the rivers are nearly dry. There are also, at

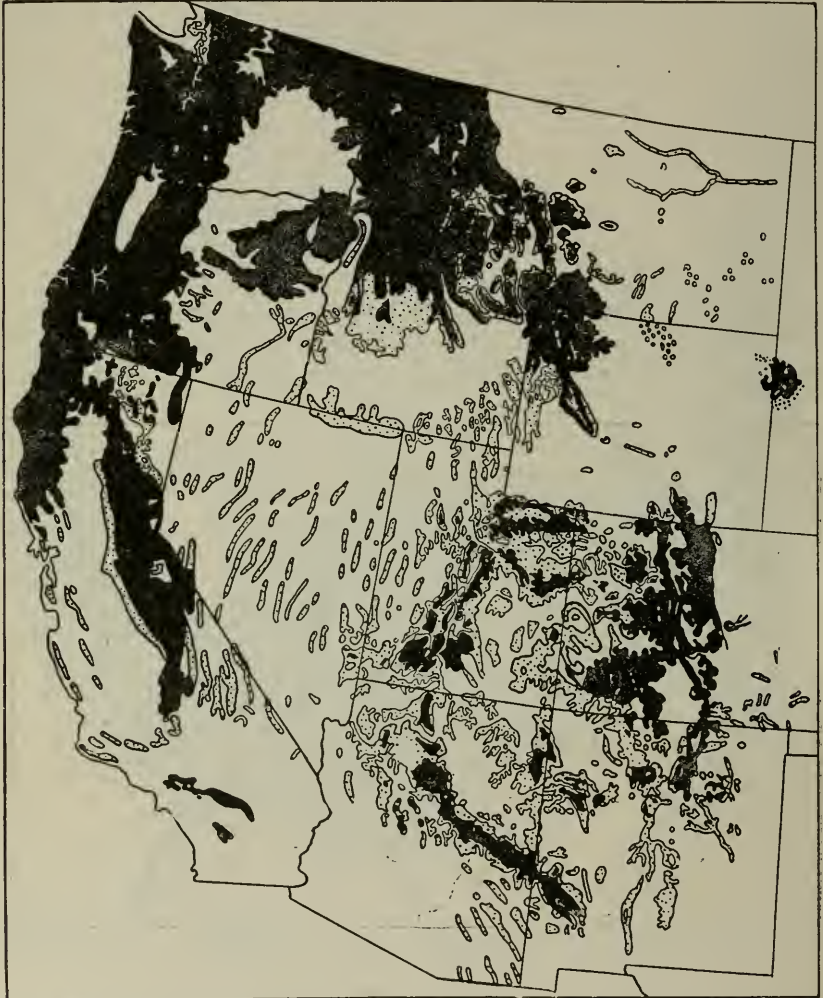

FIG. 3.—Map showing location of forests and woodlands of the west. [The solid black indicates the areas where trees valuable for lumber are growing, or recently have stood; the dotted areas show the open woodlands with scattered trees valuable for fence posts or other farm purposes.]

long intervals, large perennial streams, but most of these flow in narrow, deep canyons.

The country under discussion is not wholly uninhabited, but at nearly every spring and along every river which is not flowing in a narrow canyon there are to be found ranches and occasional small towns. All of the easily available sources of water supply have been





*a.* Irrigated farms in Atanum Valley, Washington.



*b.* Sunnyside fruit orchard, Yakima Valley, Washington.

DESERT LANDS NEAR PACIFIC COAST RECLAIMED BY IRRIGATION.



seized, and in the aggregate over 7,500,000 acres have been brought under irrigation, this being a little over 1 per cent of the total area of the remaining vacant lands.

Not all of this 500,000,000 acres can be irrigated, for some of it is mountainous and covered in part with timber (fig. 3), other portions are rough and broken, and even if all of the floods were conserved in great reservoirs and all of the rivers which could be diverted were turned out from their canyons, there would not be water for more than 60,000,000 acres, or possibly 100,000,000 acres; but this would be a great increase—say, ten times—over the area now utilized.

In that portion of the United States where the vacant public lands lie, and where farms and homes can not be made without irrigation, there are now living 3,000,000 or 4,000,000 people. If ten times the amount of land were irrigated it is possible that the population would be increased to at least 40,000,000 people, and possibly far more, because of the other industries which would be developed as more land is cultivated. The mineral wealth of the region is very great. Gold, silver, iron, and coal are now produced, the precious metals having special value. The poorer ores are for the most part neglected, because of the high cost of transportation, labor, food, and forage. With more land cultivated in scattered areas throughout this country and with greater population better transportation facilities must come, also cheaper food material, making it possible to work some of the low-grade ores. Great deposits which are now practically valueless could then be worked, affording employment for thousands of men and adding to the population and wealth of the country. With a regulated water supply, such as that needed in irrigation, cheap water power can be had, not only for pumping water to the fields, but for various industries connected with the handling and reduction of the ores, and thus, one industry feeding another, the West must develop its wonderful resources with increasing rapidity.

But the questions may well be asked, Why is this not now taking place if there are so many people wanting land, and why is it that the settled area has actually diminished in some portions of the West and population has tended to concentrate in the towns? It is because the irrigators and investors in irrigation systems have utilized all the easily available sources of water and have developed agriculture by irrigation nearly to the limit of the capacity of the systems. They have demonstrated that irrigation is not an experiment, but an assured success, highly profitable to the man who cultivates his own land. More than this, they have shown by numerous failures that reclamation works on a large scale do not pay financially nor yield the satisfactory returns that the small works have yielded. There are no longer opportunities for small works, and if the big enterprises can not be made sources of profit, what then is to be done?

Several instances can be cited where corporations have been formed, stocks and bonds issued, and a million dollars invested in great reclamation works, in building reservoirs, dams, and canals, resulting in increasing land values in the vicinity to \$3,000,000, yet the investors lost every dollar, because they could not control and bring to themselves the profits of the enterprise. These went to the public, and under existing conditions could not be realized by the men who took the risk. The people who bought stocks and bonds of irrigation enterprises are no longer willing to play the part of philanthropist to benefit the public; and they say that "although the schemes offered are equally enticing as those in the past, we will not be led into another enterprise of this character." Hence, development has practically ceased, and compared with what might be done, the country with its vast opportunities seems almost stagnant.

The following table gives the extent of irrigation at the beginning and end of the decade 1890-1900, and shows the gradual increase of this method of tilling the soil:

*Area irrigated.*

States and Territories.	1890.	1900.
	<i>Acres.</i>	<i>Acres.</i>
Arizona .....	70,000	180,000
California .....	1,200,000	1,500,000
Colorado .....	1,000,000	1,600,000
Idaho .....	230,000	600,000
Montana .....	380,000	900,000
Nevada .....	240,000	500,000
New Mexico .....	95,000	200,000
Oregon .....	180,000	400,000
Utah .....	300,000	600,000
Washington .....	100,000	140,000
Wyoming .....	250,000	600,000
Subhumid .....	70,000	280,000
Total .....	4,115,000	7,500,000

Private enterprise has already accomplished what it can in the utilization of the smaller streams, but there still remain great rivers and torrential floods whose control is beyond the possibility of individuals or corporations seeking profitable financial enterprises. The work of reclamation, if done at all, must be through public agencies. (Pl. II.)

These facts have been recognized by President Roosevelt in his first message to Congress, and by his Secretary of the Interior, as well as by numerous writers upon social and economic questions, who are beginning to sound the note of warning against further delay, against the policy of procrastination, which allows the speculative element to gradually acquire possession of the places where water can be stored, and to render difficult or impracticable the ultimate reclamation of the public land and the creation of homes for workers.

President Roosevelt, in his clear-cut, decisive fashion, has reached to the very heart of the matter and has recommended that the Gov-

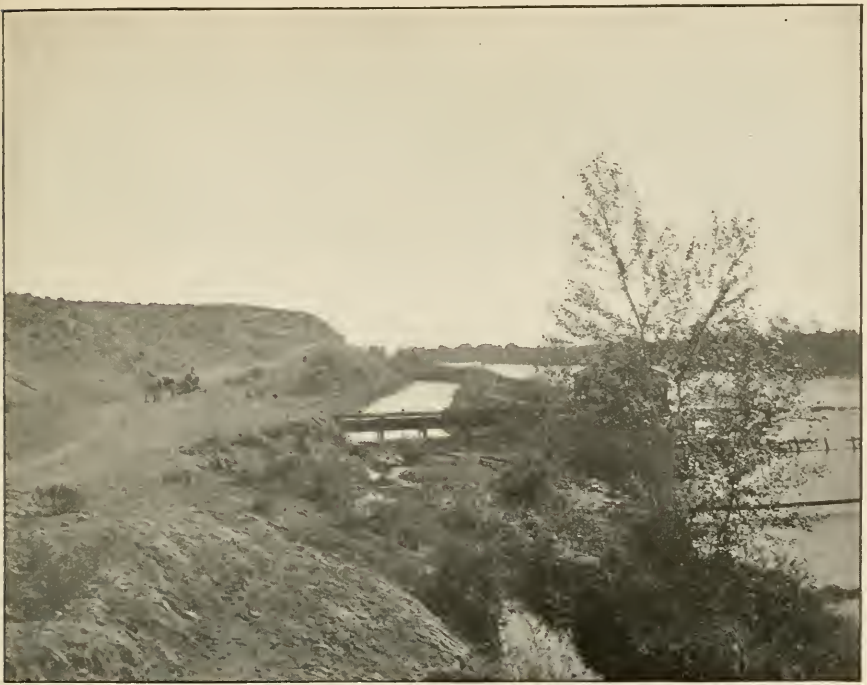

*a.* Head of Sunnyside Canal, Washington.



*b.* Along the line of Sunnyside Canal, Washington.

RESULTS OF PRIVATE ENTERPRISE IN BUILDING IRRIGATION CANALS FROM THE  
SMALLER RIVERS OF THE WEST.



ernment, the great land owner, should construct and maintain the reservoirs as it does other public works. He says that this is properly a national function, and that it is as right for the National Government to make the streams and rivers of the arid region useful, by engineering works for water storage, as it is to make useful the rivers and harbors of the humid region by engineering works of another kind.

There is a widespread demand on the part of the citizens of the country, the owners of this vast domain, for the adoption by the Government of some policy leading to the ultimate reclamation of the West, such as will permit the largest possible number of homes. The labor organizations see in this an outlet for overcrowded conditions; the manufacturing, jobbing, and transportation interests of the country appreciate the overwhelming importance of this great home market; the more intelligent farmers see here opportunities for homes for the younger members of their families and recognize that the agricultural prosperity of the country rests largely upon increased growth of manufactures and consequently enlarged demand for products. The one discordant note is from the comparatively few who do not understand that the development of the Western lands must in any event proceed slowly, and that the agricultural products of the arid region do not and never can compete with those of the East, since the character of the crops and the time when placed upon the market differ widely from those of any other section of the country.

The importance of this potential competition is overstated by some Eastern farmers. They do not appreciate the fact that wheat, corn, and other staple products of the East are not raised by irrigation, save for the most limited local consumption, and never will be, because the cost of cultivation under irrigation is such that only the highest priced products can be raised. The citrus fruits and the green and dried fruits differ from those of the East, and have in no respect reduced the price or limited the product of apples, peaches, or any other fruit of the Eastern States. For sugar beets the arid climate has been found especially suitable, but the amount raised under irrigation, even under the most favorable circumstances, can not influence the sugar market, being infinitesimal in comparison with the product of cane sugar of Louisiana, the Hawaiian Islands, or Cuba.

The fear of some of our Eastern farmers that the development of the arid West will further reduce the value of agricultural lands and products arises from a complete misapprehension of the subject. The great increase in farming area in the United States was from 1860 to 1890, in what is known as the North Central Division, including the States of Ohio, Indiana, Illinois, Michigan, Wisconsin, Minnesota, Iowa, Missouri, North and South Dakota, Nebraska, and Kansas. The improved area increased from 52,000,000 acres to 184,000,000 acres, the principal increase being in Minnesota, Iowa, the Dakotas, Nebraska,

and Kansas. Over 80,000,000 acres were brought under cultivation during these thirty years in these five States alone. The population of the United States in 1870 was less than 40,000,000, or about half what it is at present. The most extraordinary increase in cultivated area was from 1875 to 1885.

This wonderful increase of improved acreage in the North Central Division alone, of over 130,000,000 acres in thirty years (the population of the whole United States being less than half what it is now), has had an effect upon land values that can never again take place. There is no other area of agricultural land comparable to that of the Mississippi Valley. In arid regions there are vast tracts which ultimately may support a larger population, but these can not be brought under cultivation with anything like the rapidity of that practiced on the fertile prairies. Even with millions of dollars available it will not be possible to conserve water for the arid land as rapidly as the increasing population demands new farms.

At most, water can be conserved for 60,000,000 acres, or possibly 100,000,000 acres. To do this will require one or more generations. Streams must be carefully measured year after year, reservoirs surveyed, foundations examined by diamond drill or excavation, plans and estimates prepared, contracts let and masonry structures built, tunnels dug through the solid rocks, and a thousand operations be successfully performed before water can be had. Then the ditches must be dug, the laterals laid out, the grounds cleared, and the soil plowed and leveled. There can be no greater contrast, so far as time is concerned, than is offered between this necessary long preliminary work and the conditions on the fertile prairies of Iowa, where men have merely to drive the plow and plant the seed. (Pl. III.)

It is now too late to speak of Western competition with Eastern farms. This competition and its disastrous results to the far East has long since taken place. The cultivation of the prairies of Iowa, Kansas, Nebraska, and the Dakotas revolutionized agricultural values and put them on a firm basis from which they can no longer be shaken. The Mississippi Valley now sets the standard, since the area of new land in the country which can be brought under cultivation in any one year is almost inconceivably small when compared with that now cultivated.

The increase of population in the United States is from 2 to 3 per cent per year. The increase of irrigated area has been less than one-tenth of 1 per cent per year of the improved lands of the country. By the most strenuous exertions it will be impossible to increase the area of irrigated lands to 1 per cent of the improved lands of the country, or less than half the rate of increase of population.

It must not be supposed for a minute that because the increase of irrigated lands will be relatively so small as to be inappreciable in agricultural values their importance is correspondingly limited.



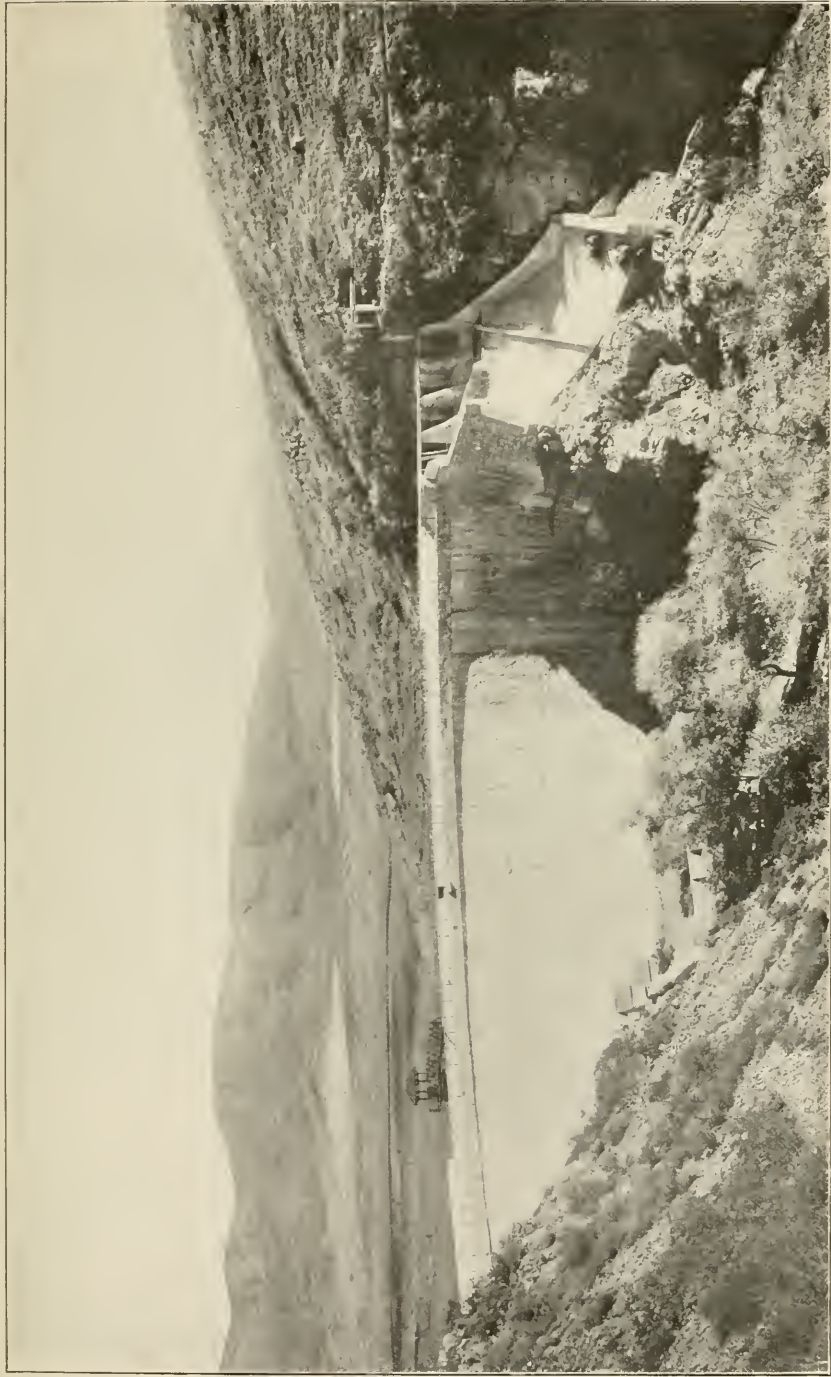

SWEETWATER DAM, SAN DIEGO, CAL. GREAT STRUCTURE SLOWLY BUILT.

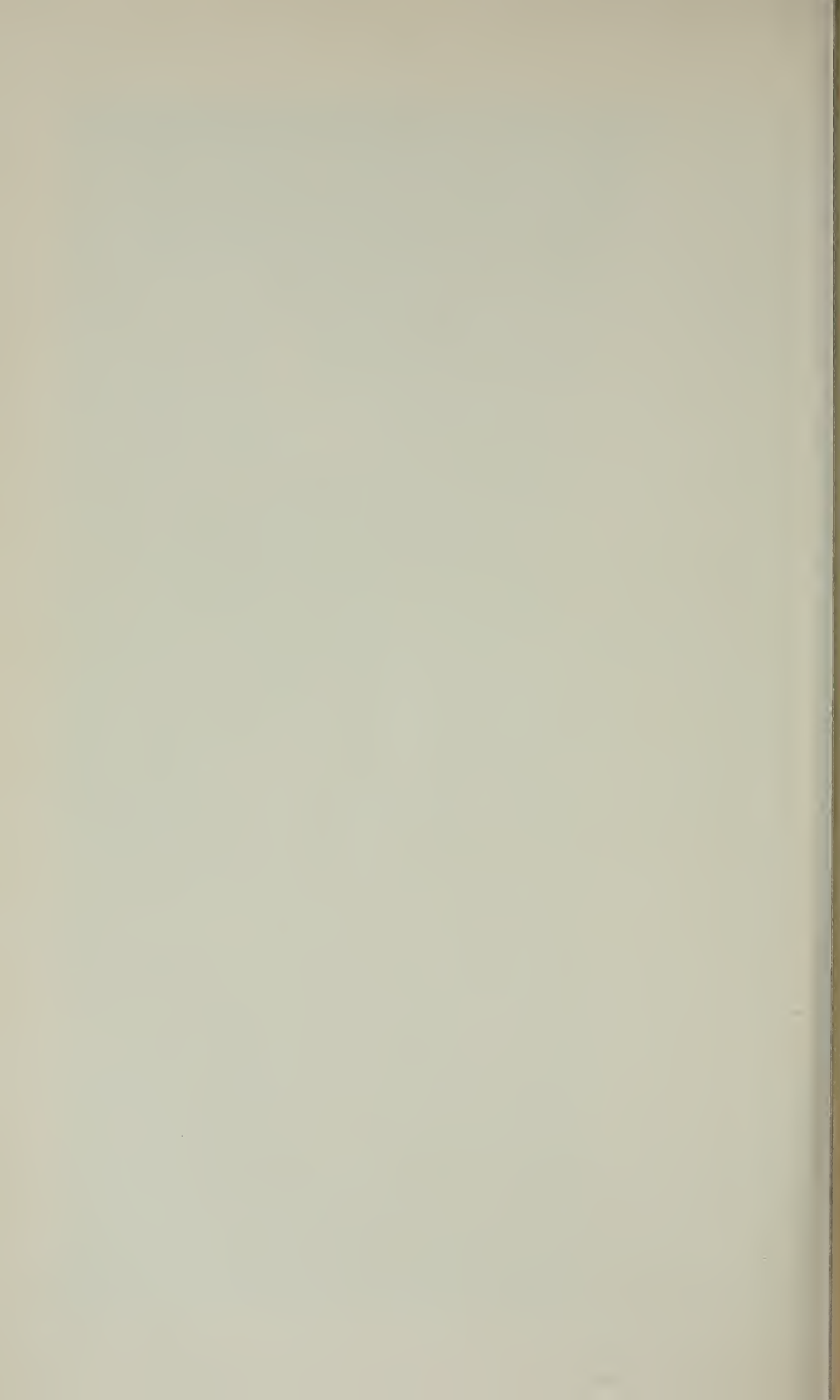

While the irrigated lands have never and can never compete with the rest of the country in agricultural values yet they afford the only remaining opportunity for the creation of homes, and they insure the highest type of agricultural and social development. The small irrigated farm, with intensive cultivation and the suburban conditions made possible under the circumstances, is the most attractive farm life, and the owners and cultivators of these farms form the most stable and substantial class of citizens, so that, although the numbers and the area may be relatively small, yet the opportunities are great.

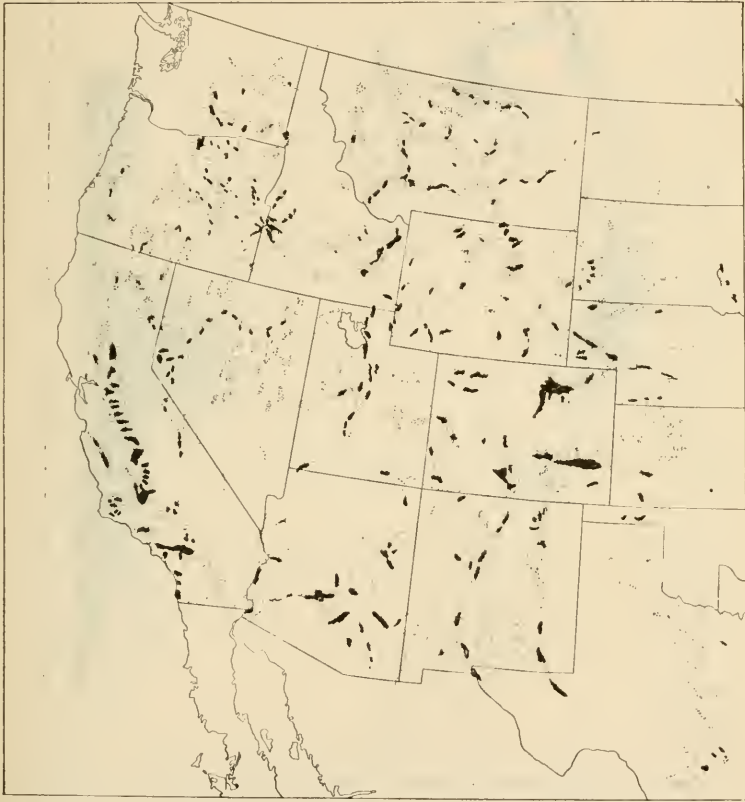

FIG. 4.—Map of irrigated and irrigable areas. [The solid black spots are the irrigated areas, the dotted areas are the localities where irrigation may be extended.]

It is estimated that by the construction of storage reservoirs, by diverting large rivers, and by sinking deep or artesian wells, it will be practicable ultimately to irrigate nearly ten times the area now cultivated by irrigation (fig. 4). There is a wide margin as to the probable acreage, and it has been placed at from 60,000,000 to 100,000,000 acres ultimately reclaimable within two or three generations. The amount, however, will depend wholly upon the treatment now accorded by Congress to the public lands. By leaving matters as they are, only a small proportion of this extent will ever be irrigated.

because of the character of the vested rights now accruing and the impossibility of entry upon these large works when the control of the water has passed into the hands of the speculative element.

National aid is not asked to secure the beginning of the work of irrigation, nor to take up an experimental enterprise. The whole object of national assistance is along the line of making it possible for the people of the country to continue to secure homes on the public

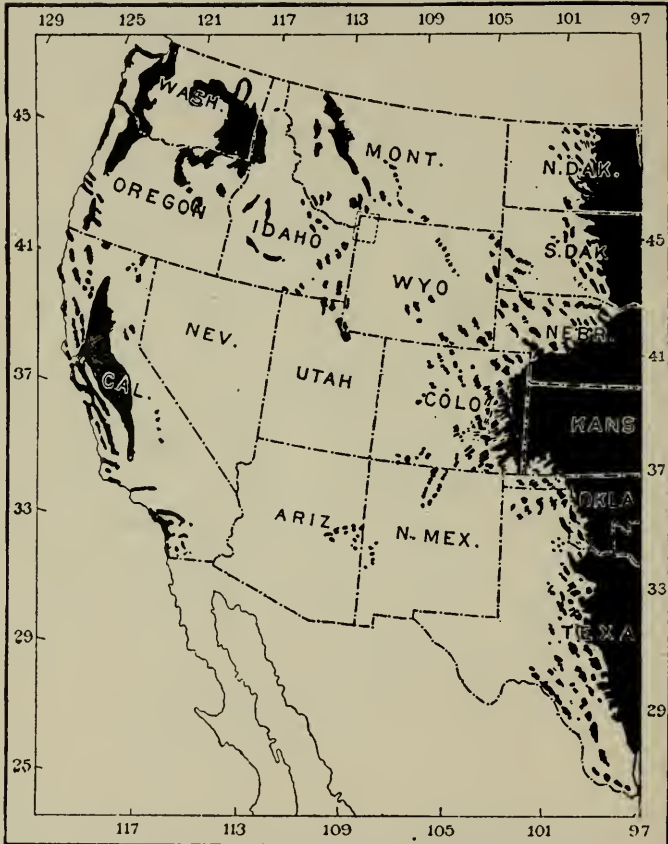

FIG. 5.—Map of dry farming areas. [The black portions show the localities where crops have been raised by dry farming.]

domain through the ability to obtain water to be brought to the land by ditches or conduits built by themselves. It is asked for the same reason that the settlers called upon the Government to protect them from the savages, from the overflows of great rivers, and to aid navigation by establishing light-houses and render it possible by dredging bars across the harbors. As before stated, none of these pay in the sense of a commercial undertaking, but the Government and the people as a whole secure a larger share of prosperity through making possible the opportunities for the pursuit of various industries.





*a.* Ruins of pioneer's sod house, abandoned from drought.



*b.* Home made possible by irrigation.

SOD HOUSES OF THE SUBHUMID PLAINS.

The National Government has already begun in part the work of reclamation by setting aside the summits of the mountains from which issue the rivers most important in irrigation, and creating these into forest reserves for the beneficial influence exercised upon the stream flow. It is necessary to go still farther, and build within these forests certain large reservoirs to store the flood waters and regulate the flow of the streams. These should never fall into private or speculative control, but should be administered for the benefit of the communities situated often in various States.

The people of the country have made strenuous efforts to utilize some of the lands now waste, and by individual experiment and failure have demonstrated that certain portions of these crops can be raised without irrigation. The accompanying small map (fig. 5) shows, in black, the localities where crops have been and can sometimes be raised by what is known as dry farming; that is, without the artificial application of water. East of the 97th meridian nearly all crops are thus raised, but west of it the dry-farming areas rapidly diminish in extent. In western Kansas and Nebraska there are comparatively few places where crops are successful more than three years out of five. During the years or cycles of unusual moisture settlement has progressed westward across these States and people have built homes, using for building material the tough sod which covers the ground, this being the only available material in a country destitute of trees and stones. The recurring droughts, however, have compelled many of these people to abandon their dry farms, and thousands of homes have been ruined, the only people left in the country being those who have secured a water supply through wells. The contrasting conditions are illustrated in Pl. IV, showing the ruined sod house and the successful home, the latter rendered possible by obtaining a water supply.

The laws and customs governing the riparian rights in the humid and semihumid portions of the country have been modified or made of no effect in the States and Territories lying within the arid region. It is there recognized that water is part of the common stock necessary for life and industry, to be drawn upon by all in accordance with certain orderly procedures. The United States, the original owner of the land, and still the possessor of the greater part of it, alone has the right and the ability to conserve the waters for the best interests of the several States and communities. Proprietorship of water should never be recognized, but the rights of each person who can put a certain amount to beneficial use should be clearly recognized and guarded in the order of priority, beneficial use being the measure and the limit of any right.

The laws in the different States of the arid region differ widely, but there are certain underlying principles which are being established by

court decisions, and through these most of the complications are being satisfactorily solved. The conditions which arise where a stream crosses State borders are, however, beyond the control of local legislatures and must come within the cognizance of Congress.

The cost of irrigation has been as low as from \$2 to \$5 per acre, irrigated by the original or pioneer ditches. This matter has been thoroughly discussed by the Eleventh and Twelfth Censuses, and the average cost of bringing water to the land throughout the country is shown to have been, in round numbers, \$12 an acre. The average annual cost of maintenance, repairs, or fees paid for conveying the water has been \$1.25 per acre. In case of more expensive works built by corporations the cost of reclaiming the lands has ranged as high as \$20 an acre, or even \$25. Such land in first cost can not compete with that offered for sale in the Mississippi Valley. The expensive irrigated lands have the advantage of continual cropping, the ground being immediately prepared for seeding as soon as one crop is removed; or, in the case of alfalfa, one cutting follows another throughout the year, as many as seven crops being had from an acre.

Private enterprise has already gone nearly to its full limit. State action has been confined almost wholly to attempted improvement in legislation and control of the distribution of the water among the irrigators. National works are being urged by those who have most thoroughly studied the subject, upon the ground that the nation alone is in a position to conserve the water supply, since it controls the land and the sources of most of the important streams. It is not suggested that there should be an interference with vested rights, nor with the distribution of water to the irrigators by State officials wherever such exist. Under any suggested combination of interests in reclamation the nation must construct the reservoirs, the large tunnels and diversion works from great rivers, the experimental deep or artesian wells (Pl. V) which demonstrate the existence of underground supplies in desert areas, and other works the magnitude of which entails cost too great for private enterprise or too far-reaching for State action.

The recognition of irrigation as a great national problem was first prominently given by Maj. John Wesley Powell, for more than thirteen years the Director of the United States Geological Survey.

In his explorations of the West, made shortly after the Civil War, Major Powell became impressed with the magnitude of the resources of the country, and the dependence of these upon water conservation and the largest development of irrigation. His report on the lands of the arid region, printed in 1879, is regarded as a classic on the subject. The weight of his personality and the impress made upon members of Congress resulted finally in the authorization, in 1888, of specific examinations of the extent to which the arid lands can be reclaimed. Soon after this work was begun, it was thought by some that this





ARTESIAN WELLS MAKING PRODUCTIVE LANDS OTHERWISE STERILE.

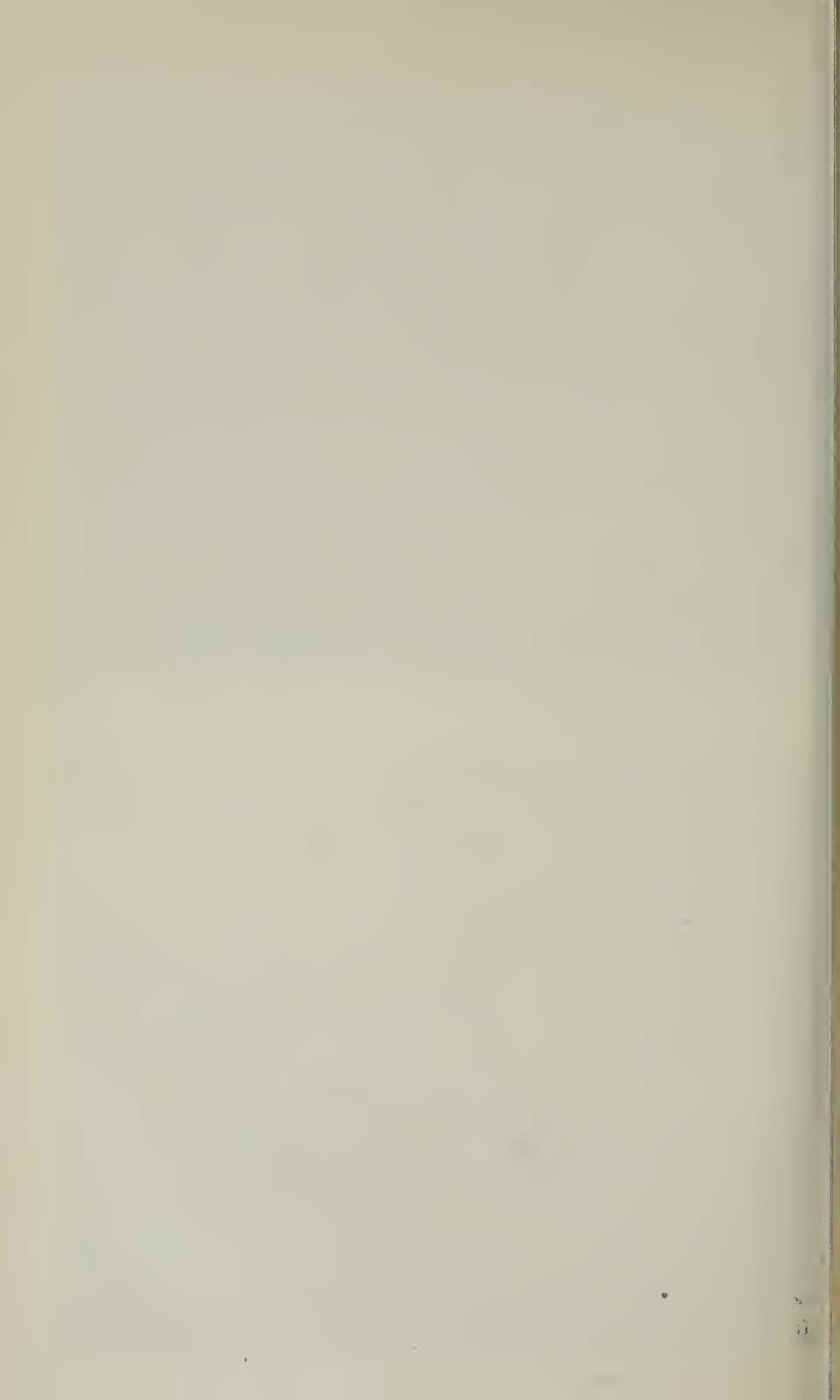

larger utilization of the resources of the West would interfere to a certain extent with other projects, and the cattlemen in particular, who at that time were not friendly to the development of irrigation, protested against what they termed national "interference" with their exclusive use of the lands belonging to all.

A select committee of the United States Senate was appointed to investigate the whole subject, and made a trip through the arid lands, accompanied by Major Powell. The report of this committee, in four volumes, embodies the observations and testimony, together with a majority and minority report, the latter outlining the line of action which Major Powell, from his thorough study of the region, deemed most feasible.

The results of the diversity of opinion developed at that time were disastrous to immediate progress, but, public interest being aroused, resulted in the gradual crystallization of ideas along the lines which Major Powell had suggested, so that by the end of the decade, statements of facts which had aroused violent opposition at the outset were no longer disputed, but belonged to common knowledge.

It is not too much to say that the people of the United States, particularly those of the West, owe to Major Powell a debt of gratitude for the manner in which he brought forward the whole question of reclamation of the public lands and placed it far in advance of what it would otherwise have been.

The investigation of the arid regions was never actually dropped after it was once begun, although it languished for a number of years. New life and energy were infused by Major Powell's successor, the present Director of the United States Geological Survey, Hon. Charles D. Walcott, and a great popular movement has been started by an organization known as the "National Irrigation Association," composed largely of prominent citizens concerned in public affairs, philanthropists, eastern manufacturers, the representatives of transportation interests, labor leaders, and others who see in the arid West a great potential market for goods and for labor, as well as an outlet for the growing population.

A culmination has finally been reached in the report of the Secretary of the Interior recommending the immediate construction of certain large works; and most notably in the direct and incisive message of President Roosevelt, bringing the attention of Congress and the people to the fact that the utilization of the water resources of the West is one of the greatest internal questions of the day.

All intelligent legislation is best promoted when based upon full knowledge, and an enterprise so vast in its ultimate magnitude should be undertaken only after thorough study of present conditions and future needs. The actual work of construction of reclamation projects should be entered upon only after a full knowledge has been had

of the cost and benefits of each, and every individual scheme should be considered solely upon its own merits and its relation to the full ultimate development of the country. This work, as above stated, has already been committed by Congress to the Geological Survey, which in 1888 was authorized to begin the investigation of the extent to which the arid lands could be reclaimed by irrigation. In the succeeding years this organization has been systematically measuring streams, surveying reservoir sites, and has now a fully equipped and experi-



FIG. 6.—Map showing (by cross lines) approximate location and extent of open range.

enced corps of hydraulic engineers, many of whom have had experience in the construction of large works.

The necessity for prompt action is shown by the way in which the remaining public lands are being taken up by speculators. It has been pointed out by recent students and writers upon the subject that although several million acres are being disposed of annually, yet these are not passing into the hands of people who are making homes upon them, and that the homestead and desert-land act is being used as a means for securing titles to lands which are not brought under cultivation.

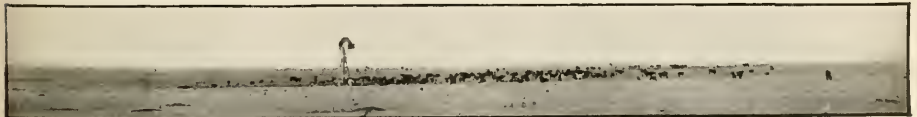
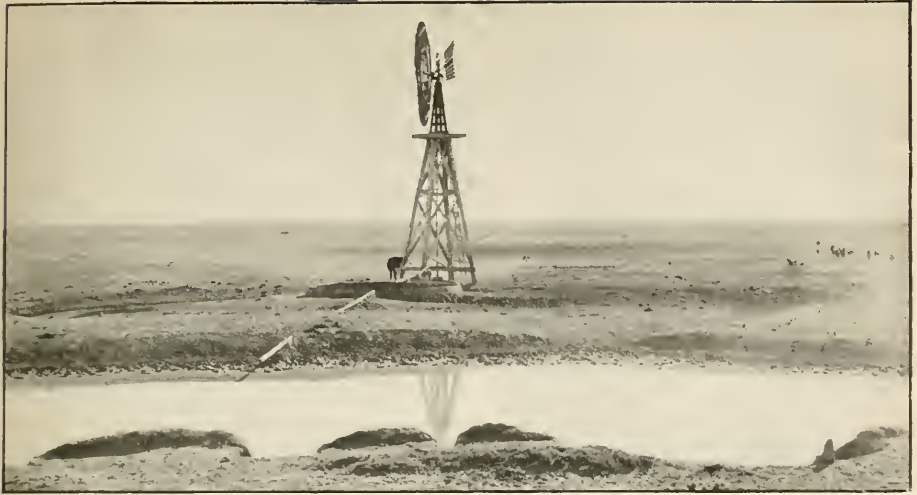

GRAZING LANDS AND WELLS UPON WHICH THEIR USEFULNESS LARGELY DEPENDS.



The greater part of the arid West is devoted to grazing. The accompanying small map (fig. 6) indicates the vast extent: the open grazing land being shown by the cross lining. Herds of cattle and flocks of sheep range over the public lands, eating the herbage without restriction, the whole country being practically an open common. This business is at times extremely profitable, and has attracted large capital, influential companies being formed. The business has increased to such an extent that the ranges have been overstocked, and, being free to all, there has been a struggle for existence.

Success in the grazing business upon the open land is dependent largely upon ability to control the water supply. If a man can obtain possession of a spring or stream he can exclude the cattle or sheep of other owners from the water, and thus be in a position to monopolize thousands of acres of grazing land, useless to others because their animals can not obtain water to drink. By systematically taking up small tracts along both sides of a stream these can be strung out in such a way as to control the water frontage, and by fencing contiguous 40-acre tracts a continuous line can be made for many miles, preventing access to water. Cattle companies have employed men with the understanding that they would thus take up land along the streams, and a glance at the map of the great unoccupied public domain shows the 40-acre tracts entered in such a fashion as to include nearly all of the running water.

The keen competition for grazing brought about by overstocking the public ranges has thus resulted in putting a premium upon lands which, while not irrigable nor suitable for farming, yet control access to water. A recent advertisement in a Western paper illustrates the condition: "For sale, 160 acres, controlling 10,000 acres of good Government grazing." No particular harm would result if the lands thus disposed of by the Government passed into the hands of men who would make best use of them, but as a rule this is not the case. Areas which might be made into many farms are held as portions of a great cattle range, the owners of which can make a larger interest on their investment by thus holding it than by attempting to conserve the water and to subdivide the land into small tracts. Many of the best reservoir sites are being taken up in one way or another by men who confessedly do not intend to utilize them, but to hold the land for sale at a good price whenever water conservation is attempted. Speculations of this kind are lawful, and may be commendable to a certain degree, but when they result in tying up some of the best land of the country and in excluding population they become injurious to the public welfare.

But the question may be asked, Why should so much interest attach to the West rather than to the humid East, where an artificial water supply need not be provided as a requisite for agriculture? The

answer is that the Government is the great landowner of the western half of the United States, and that it is for the interests of all of the people of the country to have these lands settled by men tilling their own farms; but, more than this, agriculture in an arid region yields results far greater than in humid climates or those of uncontrollable moisture. In countries where the sun shines every day the development of plant life, with proper moisture, is far greater than in regions of prevailing clouds and occasional storms. The yield per acre is greater, and where the temperature is favorable crop follows crop throughout the year. With unlimited sunshine and properly regulated moisture the farmer has a far safer and more remunerative occupation than in the East.

Irrigation properly conducted means intensive farming, the cultivation of the soil in the best possible manner, and diversified crops. The area which any one man can cultivate under such conditions is far less and the yield per acre correspondingly greater. In the best irrigated regions farms are very small, the average size of cultivated area in Utah being less than 30 acres. Small farms and the economy which must be practiced in conveying water results in comparatively dense rural population. In southern California the irrigated tracts in orchards and vineyards are so small that the farming region takes on the appearance of suburban communities. The houses, instead of being a mile apart, as on the prairies and plains of the central part of the country, are within a few rods of one another. Social intercourse is possible, good roads are assured, and rapid communication through electric car lines.

Cultivation of arid lands by means of irrigation results in a far higher type of civilization than is possible on isolated and lonely farms. Diversified agriculture, the raising of vegetables and small fruits, and the keeping of various domestic animals also necessitate greater mental as well as physical activity, continuous employment for all the members of a family, and many minor industries impossible where attention is concentrated upon a single crop, such as wheat, corn, or cotton.

The small farms so successful under irrigation make possible a colony life such as that practiced by the Mormons in Utah and exemplified in the early history of the Greeley Colony in Colorado. The success attained has led to a most interesting experiment, that of the Salvation Army helping the people to get back to the soil. In their work in big cities the Salvation Army has come across almost innumerable men and women who are eager for an opportunity to get away and start life anew in the open air. Out of the thousands of applications there have been selected certain families apparently best qualified for success, and these have been located upon small irrigable farms. Nothing is actually given these people outright except the opportunity





*a.* Orange grove irrigated by furrow method.



*b.* Young orchards under irrigation.



to help themselves. They are sold a tract of land and a small house, necessary tools, and seed upon credit, and are given a reasonable time to repay the loan thus made, with interest. From one aspect the enterprise might be regarded as money-making, but from the higher standpoint it is one of the greatest philanthropies yet undertaken.

This work of the Salvation Army in establishing colonies in Colorado and in California is really more than an experiment, for sufficient time has elapsed to give it trial, and its success may be considered as demonstrated—sufficiently, at least, to justify further and larger efforts along this line. It is not believed that the “submerged tenth” can be lifted bodily and put upon the land to become successful farmers, but the weight of humanity above this tenth, the keen struggle of those a little better off, helps to submerge the despairing portion of the community and to obstruct every avenue of escape. Relief from the congested conditions of the cities can come, in part at least, through furnishing opportunities for those who are able to go out upon the land and to become independent landowners and citizens. Ordinary farming can not offer any attraction to these people, who have spent much of their lives in the cities, as they are largely dependent upon keeping in crowds. The small farm and the suburban life possible under irrigation alone make it possible for such people to leave the city environment and become tillers of the soil.

To sum up the problem, we may say that we have a vast extent of vacant public land of wonderful fertility; we have water which will make a portion of this productive; we have the people who are seeking an opportunity to make a living, and who would gladly escape from the congestion of the cities; and we have the public funds and the public interest toward developing our country to the highest degree; but we are a long way from bringing these powerful forces to effective action. We are allowing the lands so necessary to the development of the nation to drift out of its control; we are allowing the waters and the opportunities to conserve them to be monopolized and become subject for speculation; and we are allowing barriers to be gradually erected shutting off the opportunities for development of our great internal resources.



## THE PALACE OF MINOS.<sup>a</sup>

By ARTHUR J. EVANS.

Less than a generation back the origin of Greek civilization, and with it the sources of all great culture that has ever been, were wrapped in an impenetrable mist. That ancient world was still girt round within its narrow confines by the circling "stream of ocean." Was there anything beyond? The fabled kings and heroes of the Homeric Age, with their palaces and strongholds, were they aught, after all, but more or less humanized sun myths?

One man had faith, accompanied by works, and in Dr. Schliemann the science of classical antiquity found its Columbus. Armed with the spade he brought to light from beneath the mounds of ages a real Troy; at Tiryns and Mycenæ he laid bare the palace and the tombs and treasures of Homeric kings. A new world opened to investigation, and the discoveries of its first explorer were followed up successfully by Dr. Tsountas and others on Greek soil. The eyes of observers were opened, and the traces of this prehistoric civilization began to make their appearance far beyond the limits of Greece itself. From Cyprus and Palestine to Sicily and southern Italy, and even to the coasts of Spain, the colonial and industrial enterprise of the "Mycenæans" has left its mark throughout the Mediterranean basin. Professor Petrie's researches in Egypt have conclusively shown that as early at least as the close of the Middle Kingdom, or, approximately speaking, the beginning of the second millennium B. C., imported

---

<sup>a</sup> Reprinted from the *Monthly Review*, Vol. II, London, January-March, 1901, pp. 115-132. The most scientific account of the exploration of the Cretan labyrinth is the official statement of Mr. Evans in the *Annual of the British School at Athens*, 1899-1900. The following is a brief list of papers on the subject by men who speak with authority: (1) Paul Walters in *Arch.*, August, 1900, 3, pp. 141-151 (pl.: 6 figs.); (2) Mr. Evans, *Biblia*, September, 1900; (3) Mr. Evans and Mr. D. E. Hogarth, *Biblia*, January, 1901 (see also *Biblia*, November and December, 1900); (4) Mr. Louis Dyer, *the Nation*, August 2, 1900; (5) Mr. Evans, *Murray's Monthly Magazine*, February, 1901, and (6) Mr. Hogarth in the *Contemporary Review*, December, 1900. In *Biblia*, 1901, pp. 121-128, Mr. Evans describes the recent discoveries at Knossus up to the middle of May; and the *Nation*, June 27, 1901, contains extracts from letters of Mr. Evans to the *Times* dated May 16 and June 12, telling of the latest results.

Ægean vases were finding their way into the Nile Valley. By the great days of the eighteenth dynasty, in the sixteenth and succeeding centuries B. C., this intercourse was of such a kind that Mycenaean art, now in its full maturity of bloom, was reacting on that of the contemporary Pharaohs and infusing a living European element into the old conventional style of the land of the Pyramids and the Sphinx.

But the picture was still very incomplete. Nay, it might even be said that its central figure was not yet filled in. In all these excavations and researches the very land to which ancient tradition unanimsly pointed as the cradle of Greek civilization had been left out of count. To adapt the words applied by Gelon to slighted Sicily and Syracuse, "The spring was wanting from the year" of that earlier Hellas. Yet Crete, the central island—a half-way house between three continents—flanked by the great Libyan promontory and linked by smaller island stepping stones to the Peloponnese and the mainland of Anatolia, was called upon by nature to play a leading part in the development of the early Ægean culture.

Here, in his royal city of Knossos, ruled Minos, or whatever historic personage is covered by that name, and founded the first sea empire of Greece, extending his dominion far and wide over the Ægean isles and coast lands. Athens paid to him its human tribute of youths and maidens. His colonial plantations extended east and west along the Mediterranean basin till Gaza worshipped the Cretan Zeus and a Minoan city rose in western Sicily. But it is as the first lawgiver of Greece that he achieved his greatest renown, and the code of Minos became the source of all later legislation. As the wise ruler and inspired lawgiver there is something altogether biblical in his legendary character. He is the Cretan Moses, who every nine years repaired to the cave of Zeus, whether on the Cretan Ida or on Dicta, and received from the god of the mountain the laws for his people. Like Abraham, he is described as the "friend of God." Nay, in some accounts, the mythical being of Minos has a tendency to blend with that of his native Zeus.

This Cretan Zeus, the god of the mountain, whose animal figure was the bull and whose symbol was the double ax, had indeed himself a human side, which distinguishes him from his more ethereal namesake of classical Greece. In the great cave of Mount Dicta, whose inmost shrine, adorned with natural pillars of gleaming stalactite, leads deep down to the waters of an unnavigated pool, Zeus himself was said to have been born and fed with honey and goat's milk by the nymph Amaltheia. On the conical height immediately above the site of Minos's city—now known as Mount Juktas—and still surrounded by a Cyclopean inclosure, was pointed out his tomb. Classical Greece scoffed at this primitive legend, and for this particular reason first gave currency to the proverb that "the Cretans are always liars." St. Paul, too, adopted this hard saying, but in Crete itself the new

religion, which here, as elsewhere, so eagerly availed itself of what might aid its own propaganda in existing belief, seems to have dealt more gently with the scenes of the lowly birth and holy sepulcher of a mortal god. On the height of Juktas, on the peaks of Dieta, which overlooked, one the birthplace, the other the temple of the Cretan Zeus, pious hands have built chapels, the scenes of annual pilgrimage, dedicated to Authentés Christos, "the Lord Christ." In his shrine at Gaza the Minoan Zeus had already in pagan days received the distinguished epithet of Marnas, "the lord" in its Syrian form.

If Minos was the first lawgiver, his craftsman Dædalus was the first traditional founder of what may be called a "school of art." Many were the fabled works wrought by them for King Minos, some gruesome, like the brass man Talos. In Knossos, the royal city, he built the dancing ground, or "choros," of Ariadne, and the famous labyrinth. In its inmost maze dwelt the minotaur, or "bull of Minos," fed daily with human victims, till such time as Theseus, guided by Ariadne's ball of thread, penetrated to its lair, and, after slaying the monster, rescued the captive youths and maidens. Such, at least, was the Athenian tale. A more prosaic tradition saw in the labyrinth a building of many passages, the idea of which Dædalus had taken from the great Egyptian mortuary temple on the shores of Lake Moeris, to which the Greeks gave the same name; and recent philological research has derived the name itself from the labrys, or double ax, the emblem of the Cretan and Carian Zeus.

Mythological speculation has seen in the labyrinth, to use the words of a learned German, "a thing of belief and fancy, an image of the starry heaven with its infinitely winding paths, in which, nevertheless, the sun and moon so surely move about." We shall see that the spade has supplied a simpler solution.

When one calls to mind these converging lines of ancient tradition it becomes impossible not to feel that, without Crete, "the spring is taken away" indeed from the Mycenaean world. Great as were the results obtained by exploration on the sites of this ancient culture on the Greek mainland and elsewhere, there was still a sense of incompleteness. In nothing was this more striking than in the absence of any written document. A few signs had, indeed, been found on a vase handle, but these were set aside as mere ignorant copies of Hittite or Egyptian hieroglyphs. In the volume of his monumental work which deals with Mycenaean art, M. Perrot was reduced to the conclusion that, "as at present advised, we can continue to affirm that for the whole of this period, neither in Peloponnese nor in central Greece, no more upon the buildings nor upon the thousand and one objects of domestic use and luxury that have come forth from the tombs, has anything been discovered that resembles any form of writing."

But was this, indeed, the last word of scientific exploration? Was

it possible that a people so advanced in other respects—standing in such intimate relations with Egypt and the Syrian lands where some form of writing had been an almost immemorial possession—should have been absolutely wanting in this most essential element of civilization? I could not believe it. Once more one's thoughts turned to the land of Minos, and the question irresistibly suggested itself—was that early heritage of fixed laws compatible with a complete ignorance of the art of writing? An abiding tradition of the Cretans themselves, preserved by Diodoros, shows that they were better informed. The Phœnicians, they said, had not invented letters; they had simply changed their forms; in other words, they had only improved on an existing system.

It is now seven years since a piece of evidence came into my hands which went far to show that long before the days of the introduction of the Phœnician alphabet, as adopted by the later Greeks, the Cretans were, in fact, possessed of a system of writing. While hunting out ancient engraved stones at Athens I came upon some three and four sided seals showing on each of their faces groups of hieroglyphic and linear signs distinct from the Egyptian and Hittite, but evidently representing some form of script. On inquiry I learned that these seals had been found in Crete. A clue was in my hands, and, like Theseus, I resolved to follow it, if possible to the inmost recesses of the labyrinth. That the source and center of the great Mycenæan civilization remained to be unearthed on Cretan soil I had never doubted, but the prospect now opened of finally discovering its written records.

From 1894 onward I undertook a series of campaigns of exploration chiefly in central and eastern Crete. In all directions fresh evidence continually came to light—Cyclopean ruins of cities and strongholds, beehive tombs, vases, votive bronzes, exquisitely engraved gems—amply demonstrating that in fact the great days of that "island story" lay far behind the historic period. From the Mycenæan sites of Crete I obtained a whole series of inscribed seals, such as I had first noticed at Athens, showing the existence of an entire system of hieroglyphic or quasi pictorial writing, with here and there signs of the coexistence of more linear forms. From the great cave of Mount Dicta—the birth-place of Zeus—the votive deposits of which have now been thoroughly explored by Mr. Hogarth, I procured a stone libation table inscribed with a dedication of several characters in the early Cretan script. But for more exhaustive excavation my eyes were fixed on some ruined walls, the great gypsum blocks of which were engraved with curious symbolic characters, that crowned the southern slope of a hill known as Kephala, overlooking the ancient site of Knossos, the city of Minos. They were evidently part of a large prehistoric building. Might one not uncover here the palace of King Minos—perhaps even the mysterious labyrinth itself?



These blocks had already arrested the attention of Schliemann and others, but the difficulties raised by the native proprietors had defeated all efforts at scientific exploration. In 1895 I succeeded in acquiring a quarter of the site from one of the joint owners. But the obstruction continued, and I was beset by difficulties of a more serious kind. The circumstances of the time were not favorable. The insurrection had broken out, half the villages in Crete were in ashes, and in the neighboring town of Candia the most fanatical part of the Mohammedan population were collected together from the whole of the island. The faithful Herakles, who was at that time my "guide, philosopher, and muleteer," was seized by the Turks and thrown into a loathsome dungeon, from which he was with difficulty rescued. Soon afterwards the inevitable massacre took place, of which the nominal British "occupants" of Candia were in part themselves the victims. Then at last the sleeping lion was aroused. Under the guns of Admiral Noel the Turkish commander evacuated the Government buildings at ten minutes' notice and shipped off the Sultan's troops. Crete once more was free.

At the beginning of this year I was at last able to secure the remaining part of the site of Kephala, and with the consent of Prince George's Government at once set about the work of excavation. I received some pecuniary help from the recently started Cretan exploration fund, and was fortunate in securing the services of Mr. Duncan Mackenzie, who had done good work for the British school in Melos, to assist me in directing the works. From about 80 to 150 men were employed in the excavation, which continued till the heat and fevers of June put an end to it for this season.

The result has been to uncover a large part of a vast prehistoric building—a palace with its numerous dependencies, but a palace on a far larger scale than those of Tiryns and Mycenæ. About 2 acres of this has been unearthed, for, by an extraordinary piece of good fortune, the remains of walls began to appear only a foot or so, often only a few inches, below the surface. This dwelling of prehistoric kings had been overwhelmed by a great catastrophe. Everywhere on the hilltop were traces of a mighty conflagration; burnt beams and charred wooden columns lay within the rooms and corridors. There was here no gradual decay. The civilization represented on this spot had been cut short in the fullness of its bloom. Nothing later than remains of the good Mycenaean period was found over the whole site; nothing even so late as the last period illustrated by the remains of Mycenæ itself. From the day of destruction to this the site has been left entirely desolate. For three thousand years or more not a tree seems to have been planted here; over a part of the area not even a plowshare had passed. At the time of the great overthrow, no doubt, the place had been methodically plundered for metal objects,

and the fallen débris in the rooms and passages turned over and ransacked for precious booty. Here and there a local bey or peasant had grubbed for stone slabs to supply his yard or thrashing floor. But the party walls of clay and plaster still stood intact, with the fresco painting on them, still in many cases perfectly preserved at a few inches depth from the surface, a clear proof of how severely the site had been let alone for these long centuries.

Who were the destroyers? Perhaps the Dorian invaders, who seem to have overrun the island about the eleventh or twelfth century before our era. More probably, still earlier invading swarms from the mainland of Greece. The palace itself had a long antecedent history and there are frequent traces of remodeling. Its early elements may go back a thousand years before its final overthrow, since, in the great eastern court, was found the lower part of an Egyptian seated figure of diorite, with a triple inscription, showing that it dates back to the close of the twelfth or the beginning of the thirteenth dynasty of Egypt; in other words, approximately to 2,000 B. C. But below the foundation of the later building, and covering the whole hill, are the remains of a primitive settlement of still greater antiquity, belonging to the insular Stone Age. In parts this "Neolithic" deposit was over 24 feet thick, everywhere full of stone axes, knives of volcanic glass, dark polished and incised pottery, and primitive images, such as those found by Schliemann in the lowest strata of Troy.

The outer walls of the palace were supported on huge gypsum blocks, but there was no sign of an elaborate system of fortification such as at Tiryns and Mycenæ. The reason of this is not far to seek. Why is Paris strongly fortified, while London is practically an open town? The city of Minos, it must be remembered, was the center of a great sea power, and it was in "wooden walls" that its rulers must have put their trust. The mighty blocks of the palace show, indeed, that it was not for want of engineering power that the acropolis of Knossos remained unfortified. But in truth Mycenæan might was here at home. At Tiryns and Mycenæ itself it felt itself threatened by warlike continental neighbors. It was not till the mainland foes were masters of the sea that they could have forced an entry into the house of Minos. Then, indeed, it was an easy task. In the cave of Zeus on Mount Ida was found a large brooch (or fibula) belonging to the race of northern invaders, on one side of which a war galley is significantly engraved.

The palace was entered on the southwest side by a portico and double doorway opening from a spacious paved court (fig. 1). Flanking the portico were remains of a great fresco of a bull, and on the walls of the corridor leading from it were still preserved the lower part of a procession of painted life-size figures, in the center of which was a female personage, probably a queen, in magnificent apparel. This corridor seems to have led round to a great southern porch or Propy-

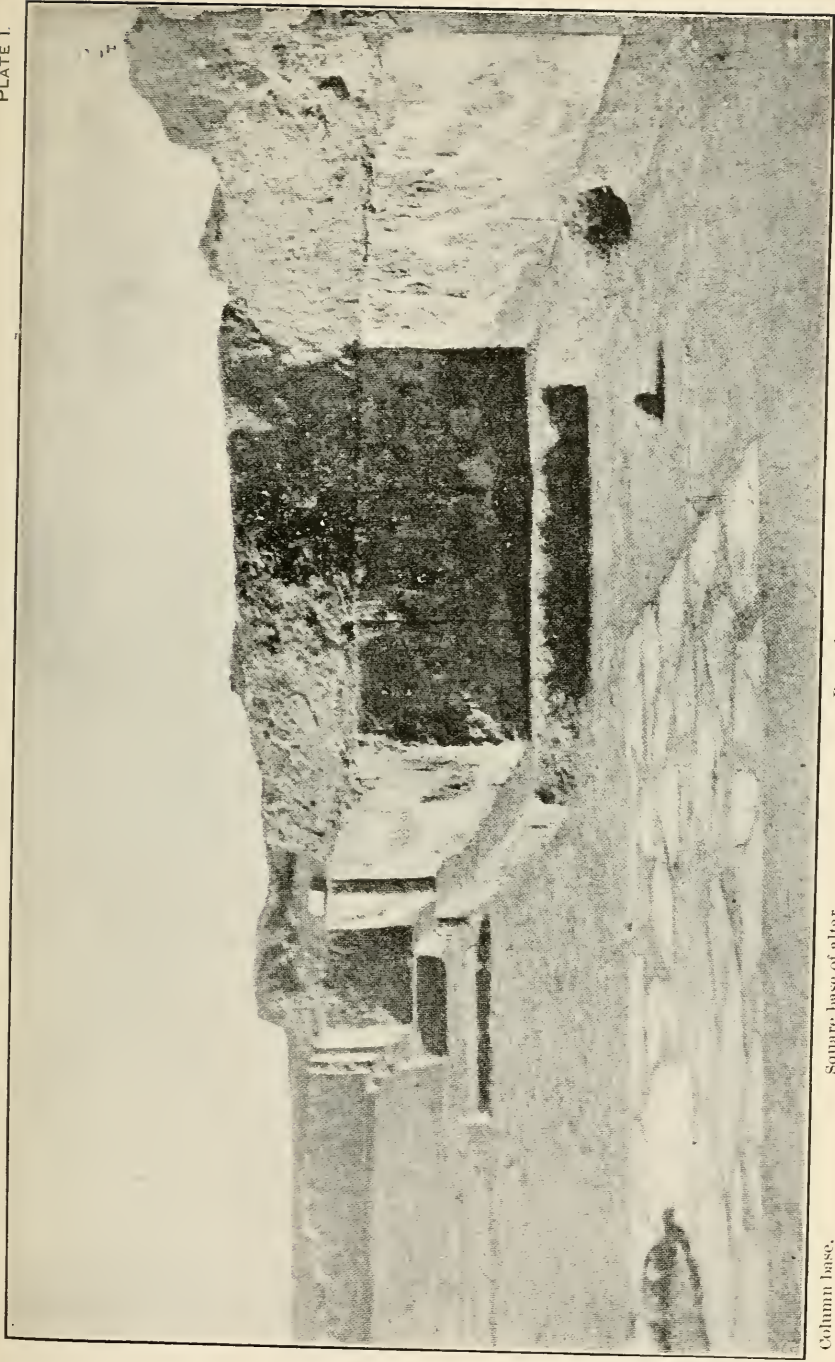

Column base.

Square base of altar.

Base of west wall of palace, of gypsum blocks.

FIG. 1.—WESTERN COURT OF THE PALACE, KNOSSOS, SEEN FROM SOUTHWEST PORTICO.





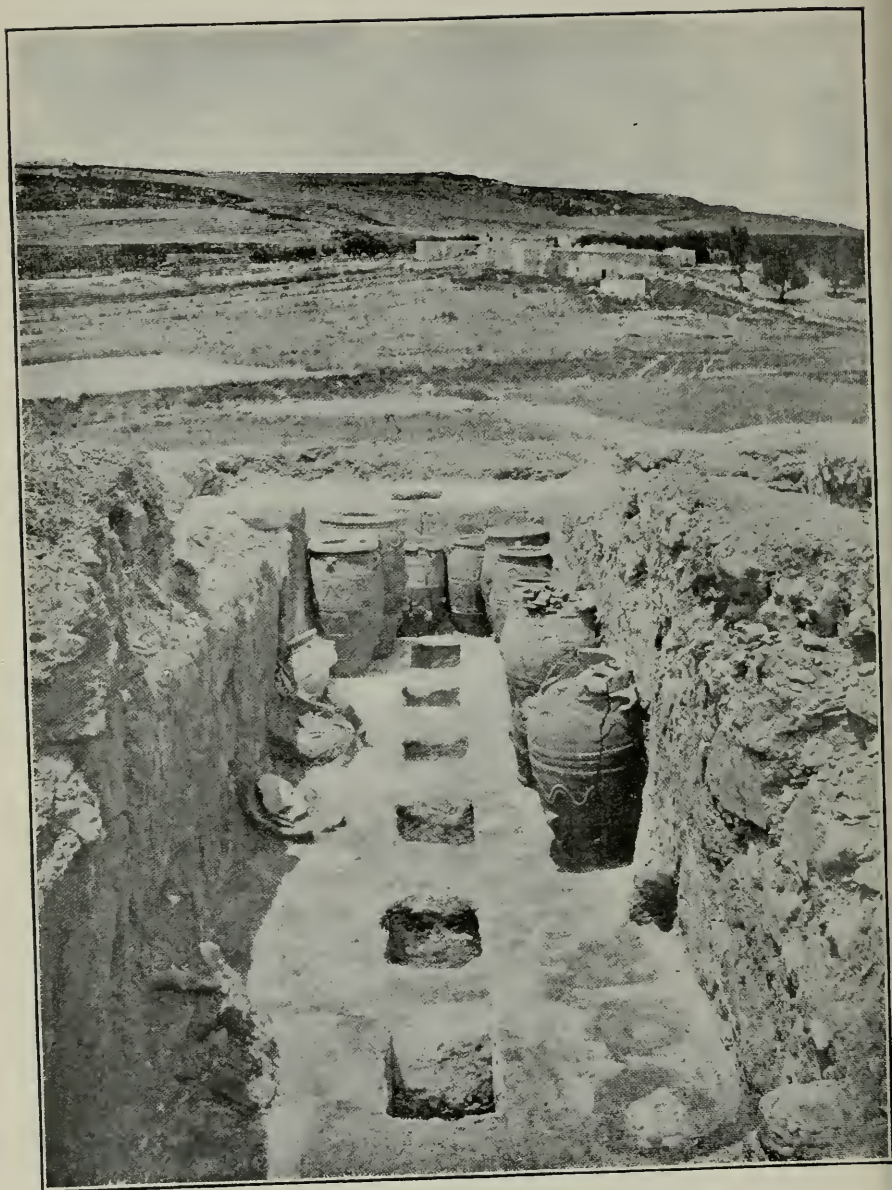
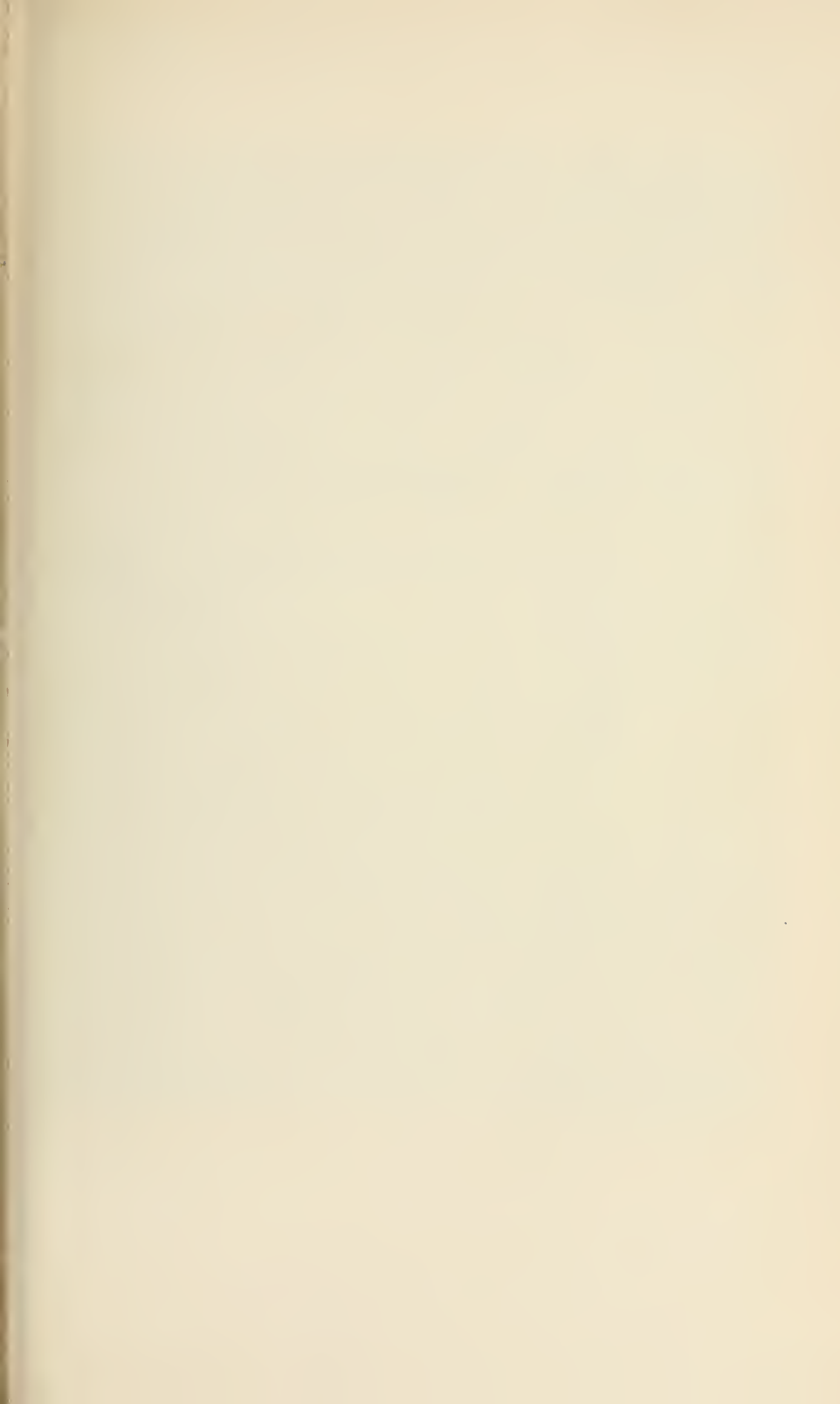

FIG. 2.—MAGAZINE NO. 5. SHOWING GREAT STORE JARS.



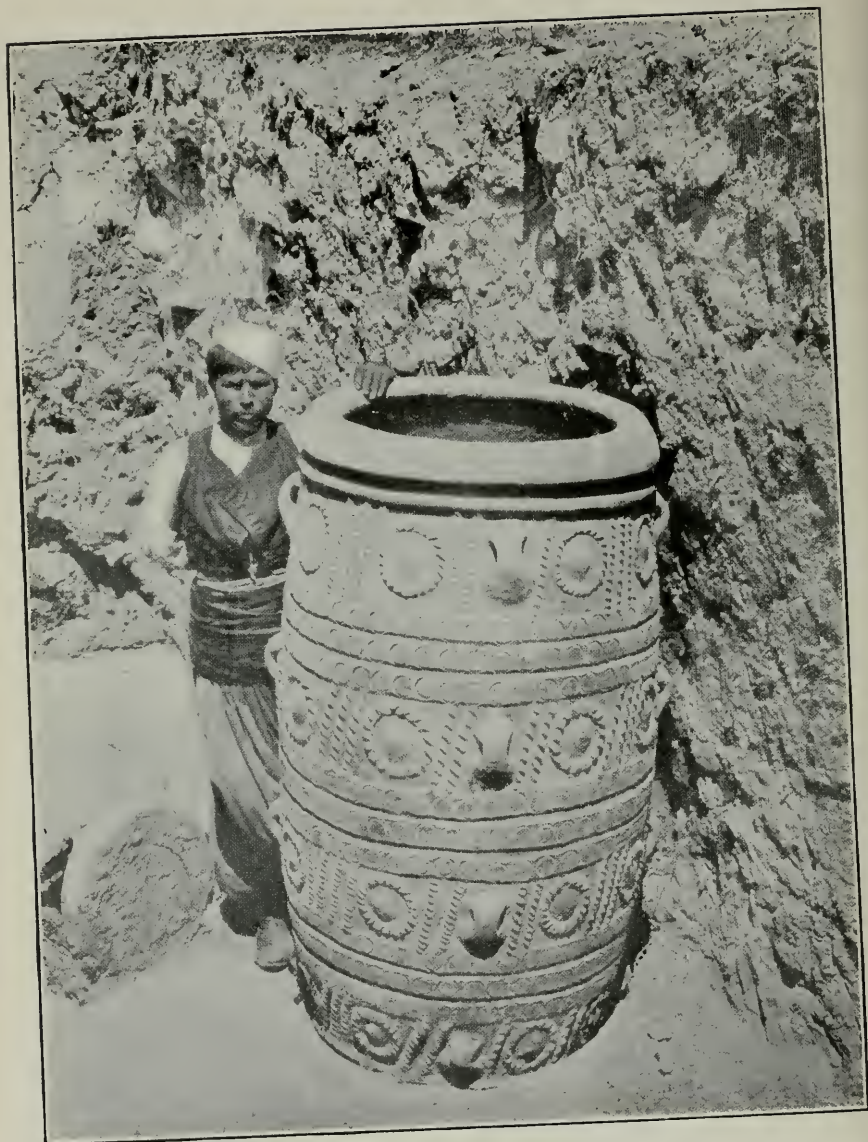
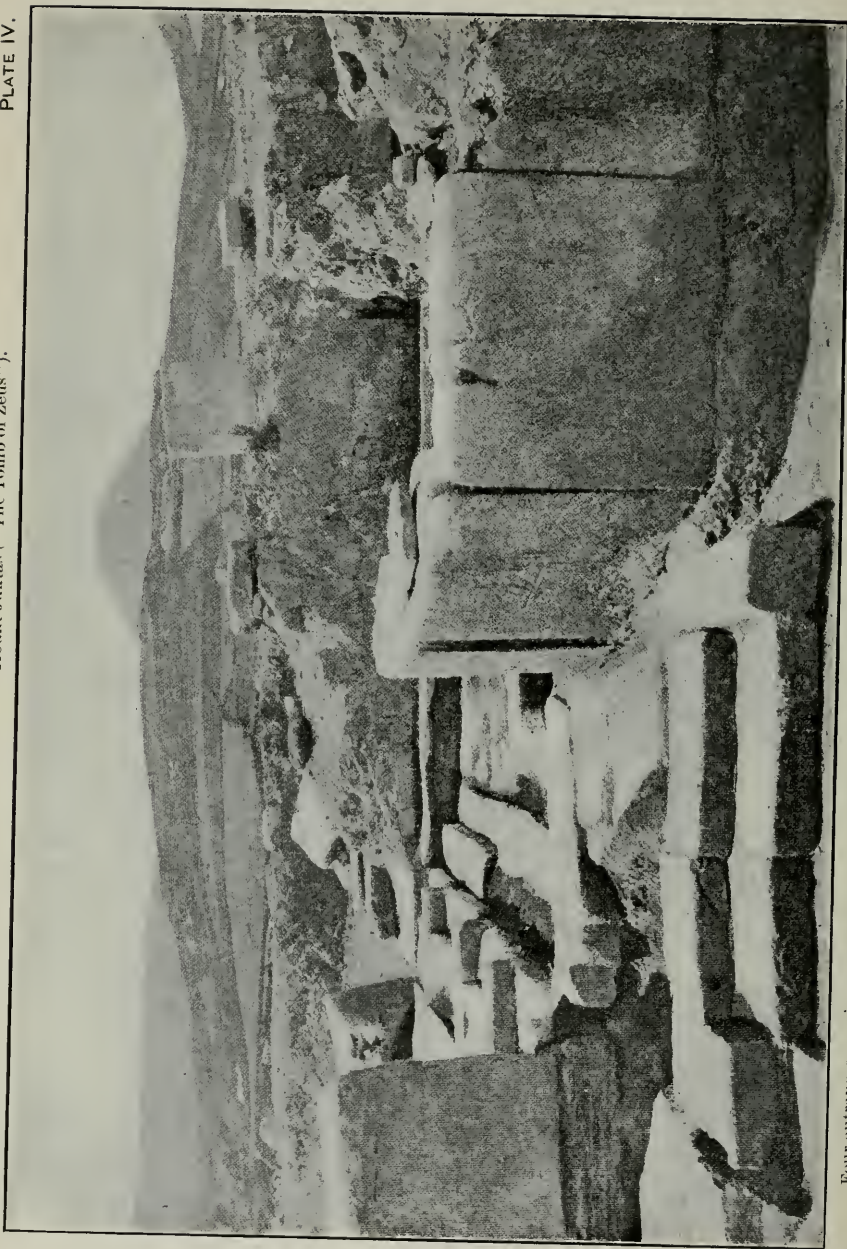

FIG. 3.—LARGE CLAY STORE JAR.







Four entrances opening on east court.

Stone bench with plasters.

Gypsum blocks of corridor with incised symbols.

FIG. 4.—ANTECHAMBER TO THRONE ROOM, SEEN FROM ITS NORTHERN ENTRANCE.



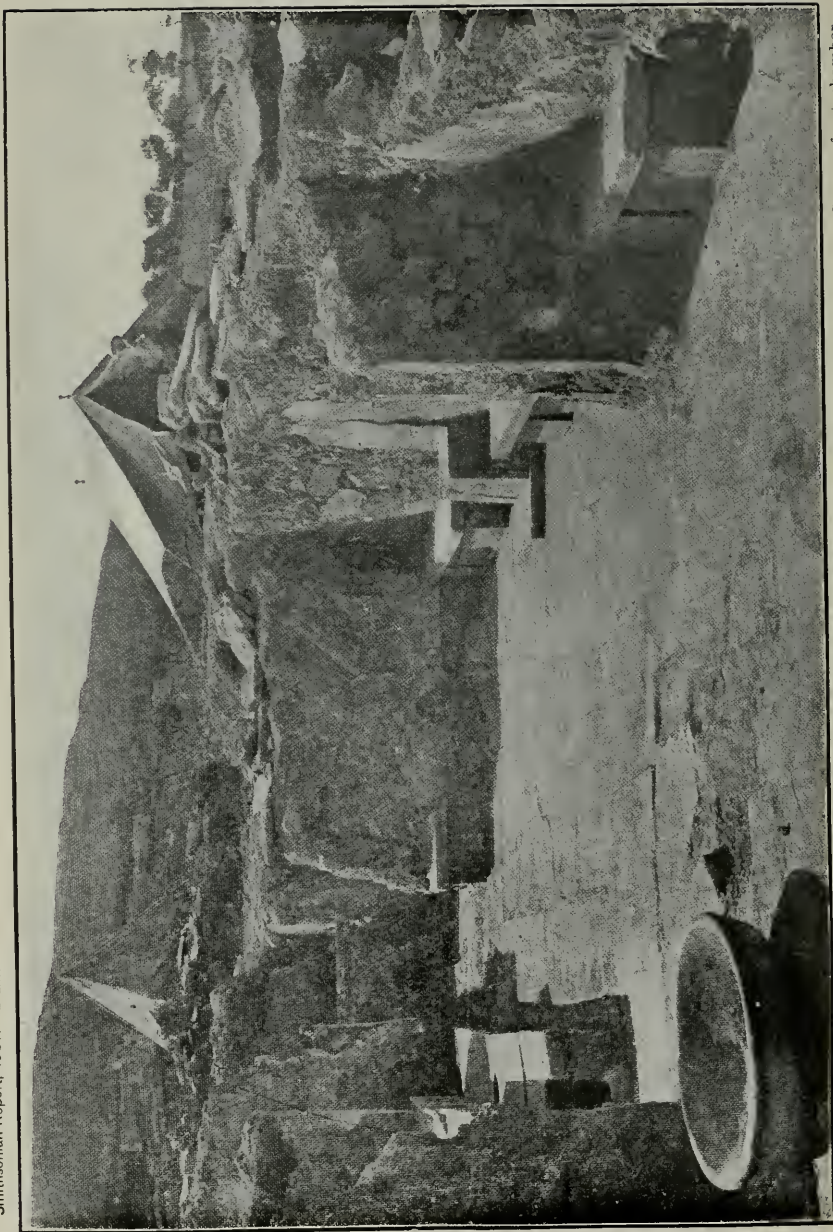

Stone breastwork of tank with sockets for wooden columns.

Doorway of inner chamber.

Stone bench and fallen pieces of fresco.

Gypsum throne between lower benches.

Corner of ante-chamber.

FIG. 5.—THRONE ROOM FROM ANTECHAMBER.

laeum with double columns, the walls of which were originally decorated with figures in the same style. Along nearly the whole length of the building ran a spacious paved corridor, lined by a long row of fine stone doorways, giving access to a succession of magazines. On the floor of these magazines huge store jars were still standing, large enough to have contained the "forty thieves" (fig. 2). One of these jars, contained in a small separate chamber, was nearly 5 feet in height (fig. 3).

Here occurred one of the most curious discoveries of the whole excavation. Under the closely compacted pavement of one of these magazines, upon which the huge jars stood, there were built in between solid piles of masonry double tiers of stone cists lined with lead. Only a few were opened and they proved to be empty, but there can be little doubt that they were constructed for the deposit of treasure. Whoever destroyed and plundered the palace had failed to discover these receptacles, so that when more come to be explored there is some real hope of finding buried hoards.

On the east side of the palace opened a still larger paved court, approached by broad steps from another principal entrance to the north. From this court access was given by an anteroom (fig. 4) to what was certainly the most interesting chamber of the whole building, almost as perfectly preserved—though some twelve centuries older—as anything found beneath the volcanic ash of Pompeii or the lava of Herculaneum. Already a few inches below the surface freshly preserved fresco began to appear. Walls were shortly uncovered decorated with flowering plants and running water, while on each side of the doorway of a small inner room stood guardian griffins with peacocks' plumes in the same flowery landscape. Round the walls ran low stone benches, and between these on the north side, separated by a small interval and raised on a stone base, rose a gypsum throne with a high back, and originally colored with decorative designs. Its lower part was adorned with a curiously carved arch, with crocketed moldings, showing an extraordinary anticipation of some most characteristic features of Gothic architecture. Opposite the throne was a finely wrought tank of gypsum slabs—a feature borrowed perhaps from an Egyptian palace—approached by a descending flight of steps, and originally surmounted by cyprus-wood columns supporting a kind of impluvium. Here truly was the council chamber of a Mycenaean king or sovereign lady. It may be said to-day that the youngest of European rulers has in his dominions the oldest throne in Europe (fig. 5).

The frescoes discovered on the palace site constitute a new epoch in the history of painting. Little, indeed, of the kind even of classical Greek antiquity has been hitherto known earlier at least than the Pompeian series. The first find of this kind marks a red-letter day in the story of the excavation. In carefully uncovering the earth and débris in a passage at the back of the southern Propylaeum there came

to light two large fragments of what proved to be the upper part of a youth bearing a gold-mounted silver cup (fig. 6). The robe is decorated with a beautiful quarterfoil pattern; a silver ornament appears in front of the ear, and silver rings on the arms and neck. What is specially interesting among the ornaments is an agate gem on the left wrist, thus illustrating the manner of wearing the beautifully engraved signets of which many clay impressions were found in the palace.

The colors were almost as brilliant as when laid down over three thousand years before. For the first time the true portraiture of a man of this mysterious Mycenaean race rises before us. The flesh tint, following perhaps an Egyptian precedent, is of a deep reddish brown. The limbs are finely molded, though the waist, as usual in Mycenaean fashions, is tightly drawn in by a silver-mounted girdle, giving great relief to the hips. The profile of the face is pure and almost classically Greek. This, with the dark curly hair and high brachycephalic head, recalls an indigenous type well represented still in the glens of Ida and the White Mountains—a type which brings with it many reminiscences from the Albanian highlands and the neighboring regions of Montenegro and Herzegovina. The lips are somewhat full, but the physiognomy has certainly no Semetic cast. The profile rendering of the eye shows an advance in human portraiture foreign to Egyptian art, and only achieved by the artists of classical Greece in the early fine-art period of the fifth century B. C.—after some eight centuries, that is, of barbaric decadence and slow revival.

There was something very impressive in this vision of brilliant youth and of male beauty, recalled after so long an interval to our upper air from what had been till yesterday a forgotten world. Even our untutored Cretan workmen felt the spell and fascination. They, indeed, regarded the discovery of such a painting in the bosom of the earth as nothing less than miraculous, and saw in it the "icon" of a saint. The removal of the fresco required a delicate and laborious process of underplastering, which necessitated its being watched at night, and old Manolis, one of the most trustworthy of our gang, was told off for the purpose. Somehow or other he fell asleep, but the wrathful saint appeared to him in a dream; waking with a start, he was conscious of a mysterious presence; the animals round began to low and neigh and "there were visions about;" "*φαντάζει*," he said, in summing up his experiences next morning, "the whole place spooks!"

To the north of the palace, in some rooms that seem to have belonged to the women's quarter, frescoes were found in an entirely novel miniature style. Here were ladies with white complexions—due, we may fancy, to the seclusion of harem life—*décolletés*, but with fashionable puffed sleeves and flounced gowns, and their hair as elaborately curled and *frisé* as if they were fresh from a *coiffeur's* hands.

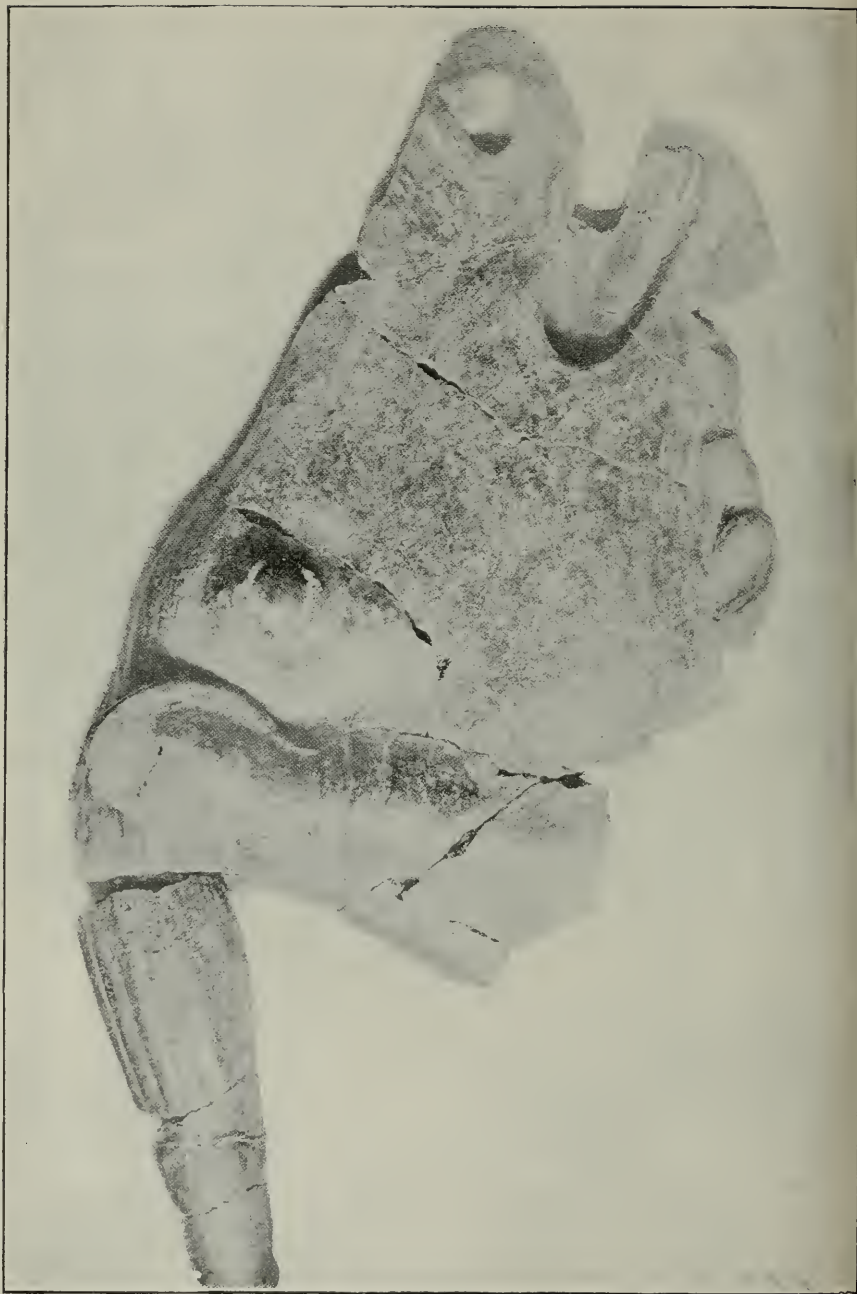

FIG. 6.—FRESCO OF THE CUPBEARER (ORIGINAL LIFE SIZE).









"Mais," exclaimed a French savant who honored me with a visit, "ces sont des Parisiennes!"

They were seated in groups, engaged in animated conversation, in the courts and gardens and on the balconies of a palatial building, while in the walled spaces beyond were large crowds of men and boys, some of them hurling javelins. In some cases both sexes were intermingled. These alternating scenes of peace and war recall the subjects of Achilles' shield, and we have here at the same time a contemporary illustration of that populousness of the Cretan cities in the Homeric age which struck the imagination of the bard. Certain fragments of fresco belong to the still earlier period of Ægean art, which precedes the Mycenæan, well illustrated in another field by the elegant painted vases found by Mr. Hogarth in some private houses on this site. A good idea of the refinement already reached in these earlier days of the palace is given by the subject of one fresco fragment in this "pre-Mycenæan" style—namely, a boy, in a field of white crocuses, some of which he has gathered and is placing in an ornamental vase.

Very valuable architectural details were supplied by the walls and buildings of some of the miniature frescoes above described. In one place rose the façade of a small temple, with triple cells, containing sacred pillars, and representing in a more advanced form the arrangement of the small golden shrines, with doves perched upon them, found by Schliemann in the shaft graves at Mycenæ. This temple fresco has a peculiar interest, as showing the character of a good deal of the upper structure of the palace itself, which has now perished. It must largely have consisted of clay and rubble walls, artfully concealed under brilliantly painted plaster, and contained and supported by a woodwork framing. The base of the small temple rests on the huge gypsum blocks which form so conspicuous a feature in the existing remains, and below the central opening is inserted a frieze, recalling the alabaster reliefs of the palace hall of Tiryns, with triglyphs, the prototypes of the Doric, and the half-rosettes of the "metopes" inlaid with blue enamel, the *Kyanos* of Homer.

A transition from painting to sculpture was supplied by a great relief of a bull in hard plaster, colored with the natural tints, large parts of which, including the head, were found near the northern gate. It is unquestionably the finest plastic work of the time that has come down to us, stronger and truer to life than any classical sculpture of the kind (fig. 7).

Somewhat more conventional, but still showing great naturalistic power, is the marble head of a lioness, made for the spout of a fountain. It, too, had been originally tinted, and the eyes and nostrils inlaid with brightly colored enamels. A part of a stone frieze, with finely undercut rosettes, recalled similar fragments from Tiryns and Mycenæ, but far surpasses them in execution.

Vases of marble and other stones abounded, some exquisitely carved. Among these was one cut out of alabaster in the shape of a great Triton shell, every coil and fold of which was accurately reproduced. A porphyry lamp, supported on a quatrefoil pillar, with a beautiful lotus capital, well illustrates the influence of an Egyptian model. But the model was here surpassed.

Among the more curious arts practiced in prehistoric Knossos was that of miniature painting on the back of plaques of crystal. A galloping bull thus delineated on an azure background is a little masterpiece in its way. A small relief on a banded agate, representing a dagger in an ornamental sheath resting on an artistically folded belt, to a certain extent anticipates by many centuries the art of cameo carving. A series of clay seals were also discovered, exhibiting impressions of intaglios in the fine bold Mycenæan style; one of these, with two bulls, larger than any known signet gem of the kind, may well have been a royal seal. The subjects of some of these intaglios show the development of a surprisingly picturesque style of art. We see fish naturalistically grouped in a rocky pool, a hart beside a water brook in a mountain glen, and a grotto, above which some small monkey-like creatures are seen climbing the overhanging crags.

But manifold as were the objects of interest found within the palace walls of Knossos, the crowning discovery—or, rather, series of discoveries—remains to be told. On the last day of March, not far below the surface of the ground, a little to the right of the southern portico, there turned up a clay tablet of elongated shape, bearing on it incised characters in a linear script, accompanied by numeral signs. My hopes now ran high of finding entire deposits of clay archives, and they were speedily realized. Not far from the scene of the first discovery there came to light a clay receptacle containing a hoard of tablets. In other chambers occurred similar deposits, which had originally been stored in coffers of wood, clay, or gypsum. The tablets themselves are of various forms, some flat, elongated bars, from about 2 to  $7\frac{1}{2}$  inches in length, with wedge-like ends; others, larger and squarer, ranging in size to small octavo (fig. 8). In one particular magazine tablets of a different kind were found—perforated bars, crescent and scallop-like “labels,” with writing in the same hieroglyphic style as that on the seals found in eastern Crete. But the great mass, amounting to over a thousand inscriptions, belonged to another and more advanced system with linear characters. It was, in short, a highly developed form of script, with regular divisions between the words, and for elegance hardly surpassed by any later form of writing.

A clue to the meaning of these clay records is in many cases supplied by the addition of pictorial illustrations representing the objects concerned. Thus we find human figures, perhaps slaves; chariots and horses; arms or implements and armor, such as axes and cuirasses;

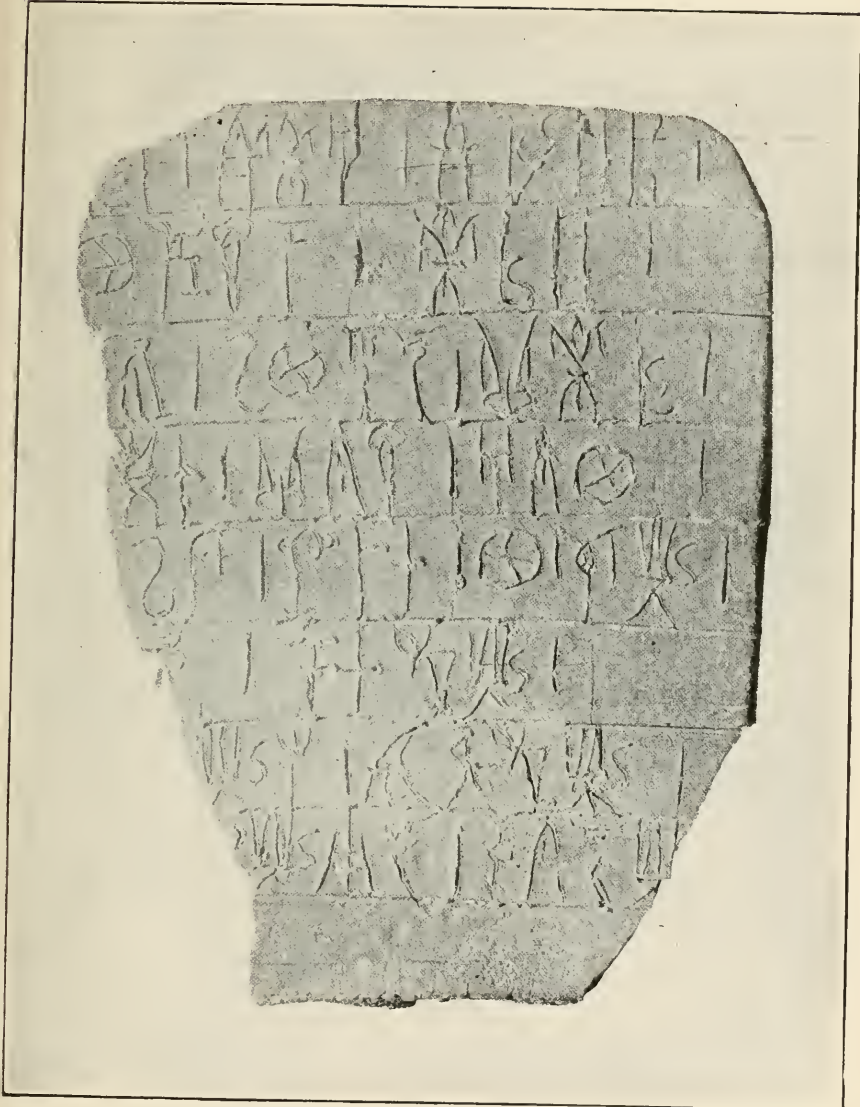

FIG. 8.—CLAY TABLET WITH THE LINEAR PREHISTORIC SCRIPT.



houses or barns; ears of barley or other cereals; swine; various kinds of trees, and a long-stamened flower, evidently the saffron crocus, used for dyes. On some tablets appear ingots, probably of bronze, followed by a balance (the Greek *τάλαντον*), and figures which probably indicate their value in Mycenæan gold talents. The numerals attached to many of these objects show that we have to do with accounts referring to the royal stores and arsenals.

Some tablets relate to ceramic vessels of various forms, many of them containing marks indicative of their contents. Others, still more interesting, show vases of metallic forms, and obviously relate to the royal treasures. It is a highly significant fact that the most characteristic of these, such as a beaker like the famous gold cups found in the Vapheio tomb near Sparta, a high-spouted ewer and an object, perhaps representing a certain weight of metal, in the form of an ox's head, recur—together with the ingots with incurving sides among the gold offerings in the hands of the tributary Ægean princes—on Egyptian monuments of Thothmes III's time. These tributary chieftains, described as Kefts and people of the isles of the sea, who have been already recognized as the representatives of the Mycenæan culture, recall in their dress and other particulars the Cretan youths, such as the cupbearer above described, who take part in the processional scenes on the palace frescoes. The appearance in the records of the royal treasury at Knossos of vessels of the same form as those offered by them to Pharaoh is itself a valuable indication that some of these clay archives approximately go back to the same period—in other words, to the beginning of the fifteenth century B. C.

Other documents, in which neither ciphers nor pictorial illustrations are to be found, may appeal even more deeply to the imagination. The analogy of the more or less contemporary tablets, written in cuneiform script, found in the palace of Tell-el-Amarna, might lead us to expect among them the letters from distant governors or diplomatic correspondence. It is probable that some are contracts or public acts, which may give some actual formulas of Minoan legislation. There is, indeed, an atmosphere of legal nicety, worthy of the house of Minos, in the way in which these clay records were secured. The knots of string which, according to the ancient fashion, stood in the place of locks for the coffers containing the tablets, were rendered inviolable by the attachment of clay seals, impressed with the finely engraved signets, the types of which represent a great variety of subjects, such as ships, chariots, religious scenes, lions, bulls, and other animals. But, as if this precaution was not in itself considered sufficient, while the clay was still wet the face of the seal was countermarked by a controlling official, and the back countersigned and indorsed by an inscription in the same Mycenæan script as that inscribed on the tablets themselves.

Much study and comparison will be necessary for the elucidation of these materials, which it may be hoped will be largely supplemented by the continued exploration of the palace. If, as may well be the case, the language in which they were written was some primitive form of Greek we need not despair of the final decipherment of these Knossian archives, and the bounds of history may eventually be so enlarged as to take in the "heroic age" of Greece. In any case the weighty question, which years before I had set myself to solve on Cretan soil, has found, so far at least, an answer. That great early civilization was not dumb, and the written records of the Hellenic world are carried back some seven centuries beyond the date of the first known historic writings. But what, perhaps, is even more remarkable than this is that, when we examine in detail the linear script of these Mycenaean documents, it is impossible not to recognize that we have here a system of writing, syllabic and perhaps partly alphabetic, which stands on a distinctly higher level of development than the hieroglyphs of Egypt or the cuneiform script of contemporary Syria and Babylonia. It is not till some five centuries later that we find the first dated examples of Phœnician writing.

The signs already mentioned as engraved on the great gypsum blocks of the palace must be regarded as distinct from the script proper. These blocks go back to the earliest period of the building, and the symbols on them, which are of very limited selection, but of constant recurrence, seem to have had a religious significance. The most constantly recurring of these, indeed, is the labrys or double ax already referred to—the special symbol of the Cretan Zeus, votive deposits of which in bronze have been found in the cave sanctuaries of the god on Mount Ida and Mount Dicta. The double ax is engraved on the principal blocks, such as the corner stones and door jambs throughout the building, and recurs as a sign of dedication on every side of every block of a sacred pillar that forms the center of what seems to have been the inmost shrine of an aniconic cult connected with this indigenous divinity.

The "house of Minos" thus turns out to be also the house of the double ax—the labrys and its lord—in other words, it is the true Labyrinthos. The divine inspirer of Minos was not less the lord of the bull, and it is certainly no accidental coincidence that huge figures of bulls in painting and plaster occupied conspicuous positions within it. Nay, more, on a small steatite relief, a couchant bull is seen above the doorway of a building probably intended to represent the palace, and this would connect it in the most direct way with the sacred animal of the Cretan Zeus.

There can be little remaining doubt that this vast edifice, which in a broad historic sense we are justified in calling the "palace of Minos," is one and the same as the traditional "labyrinth." A great part



of the ground plan itself, with its long corridors and repeated succession of blind galleries, its tortuous passages and spacious underground conduit, its bewildering system of small chambers, does in fact present many of the characteristics of a maze.

Let us place ourselves for a moment in the position of the first Dorian colonists of Knossos after the great overthrow, when features now laboriously uncovered by the spade were still perceptible amid the mass of ruins. The name was still preserved, though the exact meaning, as supplied by the native Cretan dialect, had been probably lost. Hard by the western gate in her royal robes, to-day but partially visible, stood Queen Ariadne herself—and might not the comely youth in front of her be the hero Theseus, about to receive the coil of thread for his errand of liberation down the mazy galleries beyond? Within, fresh and beautiful on the walls of the inmost chambers, were the captive boys and maidens locked up here by the tyrant of old. At more than one turn rose a mighty bull, in some cases, no doubt, according to the favorite Mycenaean motive, grappled with by a half-naked man. The type of the Minotaur itself as a man-bull was not wanting on the soil of prehistoric Knossos, and more than one gem found on this site represents a monster with the lower body of a man and the forepart of a bull.

One may feel assured that the effect of these artistic creations on the rude Greek settler of those days was not less than that of the disinterred fresco on the Cretan workman of to-day. Everything around—the dark passages, the lifelike figures surviving from an older world—would conspire to produce a sense of the supernatural. It was haunted ground, and then, as now, “phantasms” were about. The later stories of the grisly king and his man-eating bull sprang, as it were, from the soil, and the whole site called forth a superstitious awe. It was left severely alone by the newcomers. Another Knossos grew up on the lower slopes of the hill to the north, and the old palace site became a “desolation and hissing.” Gradually earth’s mantle covered the ruined heaps, and by the time of the Romans the labyrinth had become nothing more than a tradition and a name.



THE ENGRAVED PICTURES OF THE GROTTA OF LA  
MOUTHE, DORDOGNE, FRANCE.<sup>a</sup>

By M. EMILE RIVIÈRE.

INTRODUCTION, BY O. T. MASON.

The grotto of La Mouthe is in the commune of Tayac, Dordogne, France. This remarkable valley has yielded some of the most wonderful results in the history of paleolithic and neolithic man in France. The valley of the Vezère has been especially fruitful, the following well-known sites occurring there: Gorge-d'Enfer, discovered by Lartet and Christy; Cro-Magnon, explored by Massenat; les Eyzies; La Mouthe, explored by Rivière; and Laugerie-Haute.

In these caverns are found remains and human workmanship belonging to the Mousterian, Solutréan, and Magdalenian epochs. These three epochs form the close of the Paleolithic period in Europe and lead to the polished-stone people, especially of the Swiss Lake Dwellings. The following tabulated form, copied from De Mortillet's *Le Préhistorique*, will show the exact position which the discoveries made by Rivière in the cave of La Mouthe occupied in the series of epochs covering the entire history of France:

*Table of classification.*

Times.	Ages.	Periods.	Epochs.
Recent quaternary.	Historic.	Merovingian.	Wabedian. ( <i>Waben, Pas-de-Calais.</i> )
		Roman.	Champdolian. ( <i>Champdolent, Seine-et-Oise.</i> )
	Iron.	Galatian.	Lugdunian. ( <i>Lyon, Rhône.</i> )
			Beuvraysian. ( <i>Mont Beuvray, Nièvre.</i> )
			Marnian. ( <i>Département de la Marne.</i> )
	Bronze.	Tsiganian.	Hallstattian. ( <i>Hallstatt, Haute-Autriche.</i> )
			Larnaudian. ( <i>Larnaud, Jura.</i> )
			Morgian. ( <i>Morges, Canton de Vaud, Suisse.</i> )

<sup>a</sup>Translated from "*Bulletins et Mémoires de la Société d'Anthropologie de Paris.*" Sér. 5, Tome 2, p. 509, 1901.

Table of classification—Continued.

Times.	Ages.	Periods.	Epochs.	
Recent quaternary.	Prehistoric.	Neolithic.	Robenhausian. ( <i>Robenhausen, Zurich.</i> )	
			Tardenoisian. ( <i>Fère-en-Tardenois, Aisne.</i> )	
Ancient quaternary.		Stone.	Paleolithic.	Tourassian. ( <i>La Tourasse, Haute-Garonne.</i> ) Ancient Hiatus.
				Magdalenian. ( <i>La Maddeine, Dordogne.</i> )
				Solutréan. ( <i>Solutré, Saône-et-Loire.</i> )
				Mousterian. ( <i>La Mousier, Dordogne.</i> )
				Acheulean. ( <i>Saint-Acheul, Somme.</i> )
				Chellean. ( <i>Chelles, Seine-et-Marne.</i> )
				Puyecournian. ( <i>Puy-Cournay, Cantal.</i> )
				Thenaysian. ( <i>Thenay, Loir-et-Cher.</i> )
Tertiary.		Eolithic.		

For nearly ten years M. Rivière has devoted time to the exploration of these caves. His first paper was read before the Académie des Sciences, Paris.

Perhaps the most interesting feature connected with the Dordogne caves is that upon their walls have been found, from time to time, figures of animals cut into the rock or painted on the surface with ocher.

In 1878 L. Chiron called the attention of archaeologists to a grotto in the department of Gard, showing many lines cut into the sandstone wall; but it was in 1895 that M. Rivière explored another grotto or cavern—that at La Mouthe, Tayac, Dordogne. This remarkable cavern revealed, along with remains of bear and hyena, deposits of Mousterian and Neolithic relics, and also its walls and ceilings were garnished with sculptures cut in the rock and paintings in ocher.

François Daleau also brought to the attention of the public his discoveries in the grotto of Pairnon-Pair at Marcamps, Gironde, which was filled with archaeological deposits. Here the walls also were adorned with figures of animals cut in, and the interior had been filled up by Magdalenian deposits quite to the ceiling. This deposit rested upon Solutréan and Mousterian layers below, and on the walls of these there were no engravings. This fact locates the engravings somewhere between the Mousterian and the Magdalenian; that is, in or about the Solutréan, the horse epoch of ancient France.

The carvings illustrated in this paper are in continuation of Rivière's former explanations. They represent a portion only of the sculptures revealed; others will be reported on later by him.

I have the honor of presenting to the Anthropological Society of Paris reproductions of some of the new carvings discovered by me in the grotto of La Mouthe since my last communication, reserving still others for subsequent presentation.

I shall not here review the circumstances of the discovery nor the appearance of the cave when, on June 11, 1895, I penetrated the chambers previously unknown; neither shall I speak of the extensive labors undertaken at that time, and which I have since pursued each year in one or more fields of research; nor shall I describe the hearths of different epochs, Paleolithic and Neolithic, which I have discovered and in great part explored from the entrance to a certain distance inward.

Finally, I shall not enter into details concerning the fauna and the contemporaneous industry of each of those periods, whose dates may be determined with certainty. This would only needlessly repeat what I have said on several occasions here at the Institute, at the French Association, and elsewhere.<sup>a</sup> I limit myself to the presentation of the drawings which I submit to you, and to a summary description of the carvings of which they are faithful reproductions.

These drawings are at present only seven<sup>b</sup> in number, but there are several other carvings actually discovered, which lack of time has prevented me from stamping, tracing, or molding.

In the study of La Mouthe, I have simultaneously occupied myself with the exploration of hearths, the discovery of pictures, and superintending the excavation of the clay which fills the cave almost to the roof, and with greater thickness the further we penetrate.

The engravings of La Mouthe form, so to speak, a certain number of panels<sup>c</sup> on the walls of the grotto. The seven drawings of which I here present as faithful reproductions as possible, belong to three different panels: one about 97 meters from the entrance of the cavern, the second at 113 meters, the third at 128 meters. Two of the drawings belong to the first panel, one representing a bison, the other a bovine animal with some traces of another species. Three drawings are taken from the second panel and represent a reindeer, an ibex, and a mammoth. The figures from the third panel are of two horse-like animals.

(1) The species of animal represented by the first drawing (fig. 1) can not be in doubt, thanks to its enormous hump (its dimensions are indeed, much exaggerated) and to the beard which it carries under the lower jaw. It is a veritable bison (*Bos prisacus*). The creature is

<sup>a</sup> Academy of Sciences, October, 1894; June and July, 1895; April, 1897; September, 1901. French Association for the Advancement of Science, 1897. Anthropological Society of Paris, June 3, 1897; November 4 and 18, 1897; November, 1899.

<sup>b</sup> Five of them are the reproduction of tracings executed by me on October 1, 1900; the other two were made by M. H. Breuil on his second visit to the grotto of La Mouthe.

<sup>c</sup> These panels occupy a surface of several meters, and are separated from each other by more or less considerable intervals.

engraved in profile at 97 to 98 meters from the entrance and on the left wall of the grotto. The dimensions of the drawing are far from being those of the animal (0.91 meter in length from the forehead to the extremity of the tail with a height of 0.52 meter). The head is small and well drawn. The horns are well reproduced and almost

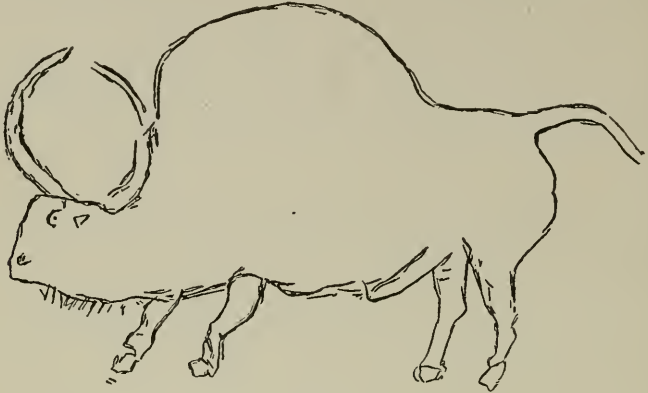

FIG. 1.

meet at their points, forming a nearly complete circle; but they have not the normal implantation of the horns of the bison. Under the lower jaw are seen numerous hairs. As to the hump which, above all, characterizes this bovid, it is enormous and, as just said, out of proportion with the dimensions of the animal. It begins behind the first



FIG. 2.

cervical vertebræ, and extends back of the sacral vertebræ or almost to the origin of the tail. The latter, relatively large at its insertion, is incurved in a quite pronounced fashion from above downward, and ends in a tapering point. The well-made legs, as well as the hind quarters, are, however, a little too thin and long. The ventral line is slightly convex downward.

(2) The next drawing is also of a bovid, perhaps even of two bovids, considering the confusion of the strokes. In any case, there is no suggestion of a bison. Here, in fact, there is no trace of a dorsal

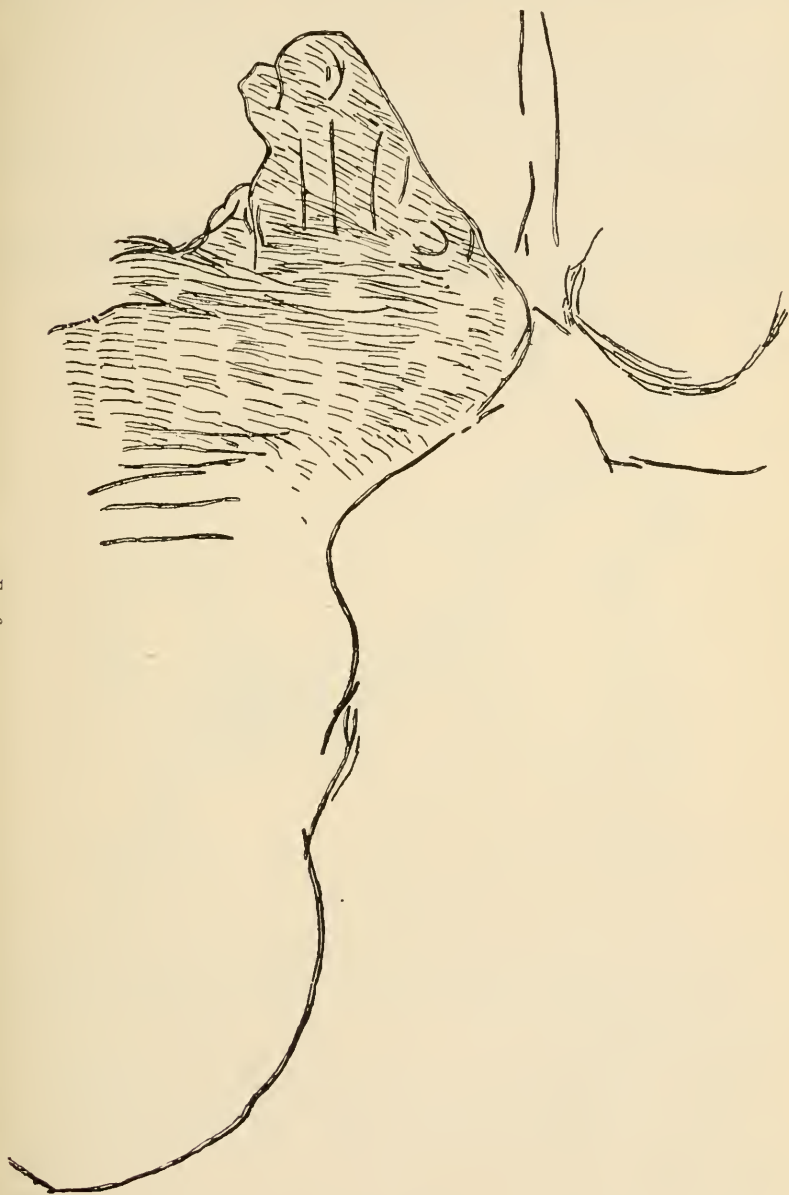

FIG. 3.

prominence, or of any hump whatever, nor any hair on the chin. The drawing measures 0.88 meter in length and 0.55 meter in height (fig. 2). The two animals which it represents, if two animals there

be, have only a single head. The latter is fine and would seem to be rather that of one of the Cervidæ, were it not for the two horns which surmount the forehead and which are recurved into nearly a complete circle, the two points being separated by only  $3\frac{1}{2}$  centimeters. Between the two horns are seen a sort of ear—the right ear—but badly inserted. The two front legs are certainly those of a bovid. As to the hind limbs, they, as well as the rump, appear to belong to a second animal surmounting the first, and of which we can perceive no more than the dorso-cervical line which curves back in front, simulating a head.

The bovid, properly so called, is drawn in left profile, while the bison is seen from the right, and upon the flank are a few marks,



FIG. 4.

some parallel and others intercrossing, which descend to the ventral line. By its intricacies this figure offers great analogies with the drawings engraved on bone or reindeer horn, which are found in the Magdalenian hearths.

I ought to add that, above this double figure, we still see two engraved lines joining each other below in such a manner as to resemble the leg of another animal whose picture has been commenced on the same panel.

(3) The engraving of the reindeer (fig. 3) is one of the most beautiful known. It measures 1.07 meters in length. The head of the animal is very well executed, I should say even in a remarkable manner; consequently it is among the more easily recognizable. It



is strong, all striated with a multitude of strokes, either vertical or slightly slanted from the right downward to the left, some of which reach the throat. They represent the hair. The head, seen in profile, is surmounted by a horn with its basal antler directed horizontally from behind toward the front.

The muzzle is very well drawn. On the contrary, the body is proportionally too short, measuring 0.70 meter from the front part of the neck to the tail. I may add that the animal is incompletely figured, for the withers scarcely exist and a line only partially indicates the back and rump.

(4) The picture of an ibex (fig. 4) now follows. Here the whole animal is given with the exception of the extremities of the front legs. It measures 0.80 meter in length by 0.77 meter in height. The head is too small in proportion to the body and is surmounted by a large



FIG. 5.

horn curved backward in a half circle. The ears are straight and well formed. The muzzle is well executed, but the jaw is too short. Then comes a neck much too large, resembling somewhat that of a bovid. The breast and belly are enormous. The line of the latter descends very low in front, while the dorsal line is nearly straight, being slightly incurved to denote the slope of the rump and then the tail. The last, directed horizontally, is short and ends in a two-forked tuft. As to the limbs, the anterior are not terminated, and their length is about half that of the hind legs, which are thin and very long.

In front of the ibex, and turned toward him so that the two heads face each other, is seen the engraving of a long-haired elephant. Although the animal is not complete, it does not seem to us possible to deny that it is intended for a mammoth. This is, moreover, also the opinion of those of my colleagues in the society to whom I showed the drawing (fig. 5) before the opening of the session. The form of

the cranium, the dorsal line, the tail, the origin also of the limbs and their size, finally the numerous strokes resembling hairs, which pass downward from the belly, are indeed those of a mammoth; but neither the trunk of the animal nor its tusks can be discerned. The dimen-

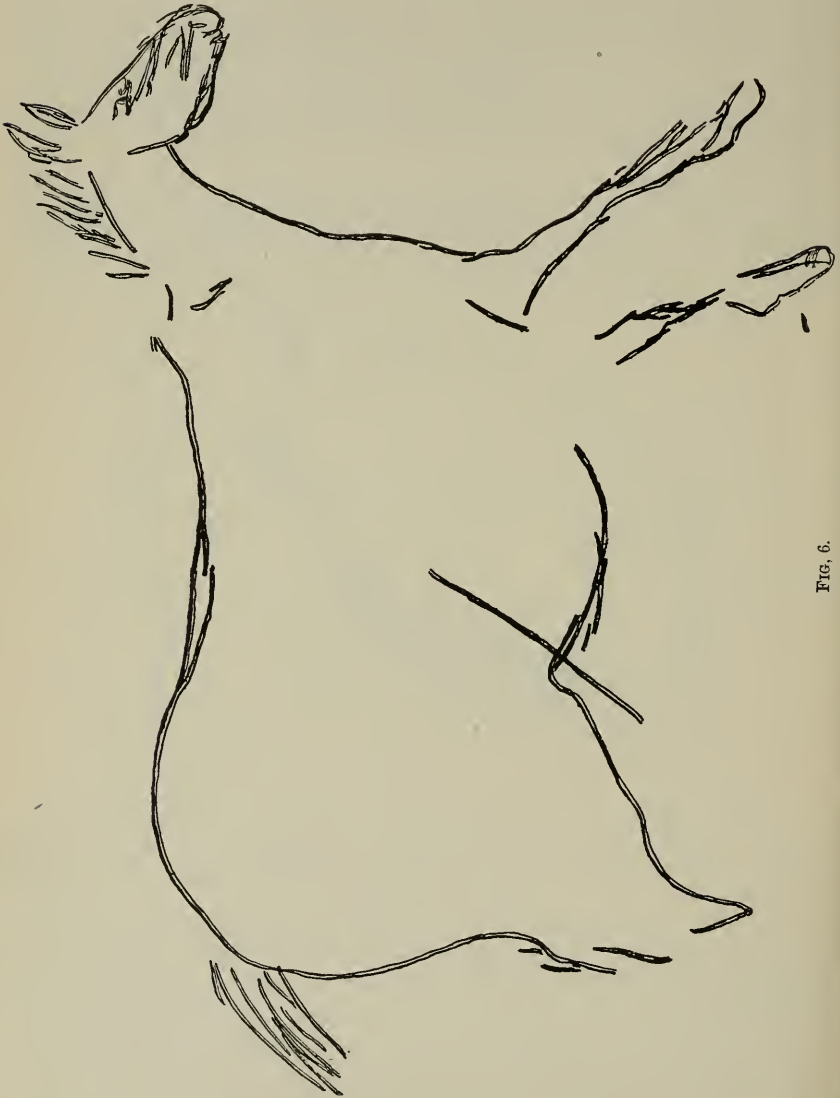

FIG. 6.

sions of the engraving are much reduced, 0.32 meter in length by 0.25 meter in height, all marks included.

Such are the drawings from this prehistoric panel, selected among others of which I shall eventually make tracings.

(6, 7) As to the two figures of the panel, situated at 128 meters from

the entrance, shown in the next pictures, they represent two equids, entirely different from each other, and appearing to belong to two distinct species—the horse and the hemione. The one has the head fine, well drawn (fig. 6), as well as the neck, the breast, and the fore legs, which are entire, hoofs included, and pretty well proportioned. The ears are straight and the mane is erect. On the contrary, the buttocks are enormous, the belly is very large, pendulous, so to speak, the line of the withers is straight, without the least incurving; finally the croup is much too pronounced, and the short tail is drooping. As to the hind legs, they are barely sketched.

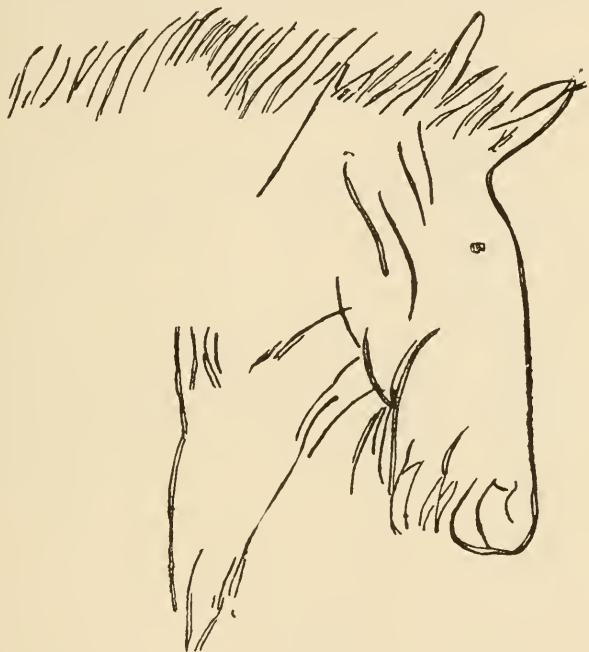

FIG. 7.

The engraving of this equid measures 0.75 meter in length from the line of the nose to the tip of the tail, and 0.55 meter in height.

The other drawing (fig. 7) is that of a kind of bearded horse whose long and bristling mane extends almost to the withers. The head is both long and directed vertically downward, the ears are somewhat long, the forehead is projecting, and the chin has a tuft of hairs. In departing from the neck, the body is represented only by a single line—the dorsal line—which extends from the mane to the tail, figured here by several strokes about 0.35 meters long. This drawing measures in all 1.31 meters in length.

It is on this panel of the two equids that several other animals appear, such, for example, as a sort of bird (genus *Anas* ?) recently

discovered; a deer, spotted, or rather in part painted with ocher, whose reproduction figured last year with that of two other animals—the bison and a bovid, or equid—at the Universal Exposition in the section of megalithic monuments, at the request of the minister of public instruction.

Such are the seven drawings which I wish to present to you to-day. I add also the reproduction of the well-made head of an ibex, which we see on the outer face of the lamp in sandstone from La Mouthe (fig. 8).

As can be seen from this figure, which is identical in size with the original, this head of the ibex is almost as remarkably executed as that of the reindeer which we have reproduced in fig. 3. The head



FIG. 8.

on the lamp is that of a profile in all its details—nose, mouth, eye, ear, and finally horns, which are of considerable length, measuring not less than 12 or 13 centimeters, and strongly curved in a semicircle.<sup>a</sup> There is nothing, even to the beard of the animal, which has not been engraved. The oval of the head measures 0.035 meter in length, and its greatest breadth is 0.023 meter. Two lines of unequal length, but nearly parallel, one descending from the left angle of the jaw, the other beginning behind the left ear, seem to attempt the representation of the neck. On the other hand, the body and the legs are not figured. We perceive only, behind the line of the neck, several engraved lines, very much defaced and without any significance.

<sup>a</sup>The lamp in sandstone from the grotto of La Mouthe (Dordogne), by Emile Rivière, 1899.

Such is, in a few words, the description of the engraved sketches coming from the grotto of La Mouthe which I desire to present to you to-day.

THE ENGRAVINGS FROM PEUCH, BY M. EMILE RIVIÈRE.

I desire also to submit to-day for your examination one of the pictures which I have taken of the very curious engravings executed upon the wall of rock against which abut buildings of a farmhouse belonging to the village of Peuch. This presentation is merely to fix the date of this discovery, which goes back to the 5th of September, 1896, and was made by me in company with Dr. Burette, who had informed me of it a few days before.

It represents a human being whose sex is not indicated. The engraving is very deeply scored in the rock. The individual measures 0.98 meter in height. The head, drawn from the front, is a simple oval, without eyes, nose, mouth, or ears. The arms are brought forward in such a way that the right hand is held upon the abdomen and the left hand hides the sex. The lower limbs end without feet at the level of the soil.

To what date does this engraving go back? This is a question which I shall examine subsequently in presenting the drawing of a second human being, engraved likewise in sunken lines, nearly of the same size as this one—an engraving of which I limit myself to-day to make the announcement without entering further into details.



## THE MIND OF PRIMITIVE MAN. <sup>a</sup>

BY FRANZ BOAS.

One of the chief aims of anthropology is the study of the mind of man under the varying conditions of race and of environment. The activities of the mind manifest themselves in thoughts and actions, and exhibit an infinite variety of form among the peoples of the world. In order to understand these clearly, the student must endeavor to divest himself entirely of opinions and emotions based upon the peculiar social environment into which he is born. He must adapt his own mind, so far as feasible, to that of the people whom he is studying. The more successful he is in freeing himself from the bias based on the group of ideas that constitute the civilization in which he lives, the more successful he will be in interpreting the beliefs and actions of man. He must follow lines of thought that are new to him. He must participate in new emotions, and understand how, under unwonted conditions, both lead to actions. Beliefs, customs, and the response of the individual to the events of daily life give us ample opportunity to observe the manifestations of the mind of man under varying conditions.

The thoughts and actions of civilized man and those found in more primitive forms of society prove that, in various groups of mankind, the mind responds quite differently when exposed to the same conditions. Lack of logical connection in its conclusions, lack of control of will, are apparently two of its fundamental characteristics in primitive society. In the formation of opinions, belief takes the place of logical demonstration. The emotional value of opinions is great, and consequently they quickly lead to action. The will appears unbalanced, there being a readiness to yield to strong emotions, and a stubborn resistance in trifling matters.

In the following remarks I propose to analyze the differences which characterize the mental life of man in various stages of culture. It is a pleasant duty to acknowledge here my indebtedness to my friends and colleagues in New York, particularly to Dr. Livingston Farrand, with whom the questions here propounded have been a frequent theme of animated discussion, so much so, that at the present time I find it impossible to say what share the suggestions of each had in the development of the conclusions reached.

<sup>a</sup> Address of the retiring president before the American Folk-Lore Society, Baltimore, December 27, 1900. Reprinted, by permission of the author, from *The Journal of American Folk-Lore*, Boston and New York, vol. xiv, Jan.-March, 1901.

There are two possible explanations of the different manifestations of the mind of man. It may be that the minds of different races show differences of organization; that is to say, the laws of mental activity may not be the same for all minds. But it may also be that the organization of mind is practically identical among all races of man; that mental activity follows the same laws everywhere, but that its manifestations depend upon the character of individual experience that is subjected to the action of these laws.

It is quite evident that the activities of the human mind depend upon these two elements. The organization of the mind may be defined as the group of laws which determine the modes of thought and of action, irrespective of the subject-matter of mental activity. Subject to such laws are the manner of discrimination between perceptions, the manner in which perceptions associate themselves with previous perceptions, the manner in which a stimulus leads to action, and the emotions produced by stimuli. These laws determine to a great extent the manifestations of the mind.

But, on the other hand, the influence of individual experience can easily be shown to be very great. The bulk of the experience of man is gained from oft-repeated impressions. It is one of the fundamental laws of psychology that the repetition of mental processes increases the facility with which these processes are performed, and decreases the degree of consciousness that accompanies them. This law expresses the well-known phenomena of habit. When a certain perception is frequently associated with another previous perception, the one will habitually call forth the other. When a certain stimulus frequently results in a certain action, it will tend to call forth habitually the same action. If a stimulus has often produced a certain emotion, it will tend to reproduce it every time.

The explanation of the activity of the mind of man, therefore, requires the discussion of two distinct problems. The first bears upon the question of unity or diversity of organization of the mind, while the second bears upon the diversity produced by the variety of contents of the mind as found in the various social and geographical environments. The task of the investigator consists largely in separating these two causes and in attributing to each its proper share in the development of the peculiarities of the mind. It is the latter problem, principally, which is of interest to the folk-lorist. When we define as folk-lore the total mass of traditional matter present in the mind of a given people at any given time, we recognize that this matter must influence the opinions and activities of the people more or less according to its quantitative and qualitative value, and also that the actions of each individual must be influenced to a greater or less extent by the mass of traditional material present in his mind.

We will first devote our attention to the question, Do differences exist in the organization of the human mind? Since Waitz's thorough



discussion of the question of the unity of the human species there can be no doubt that in the main the mental characteristics of man are the same all over the world; but the question remains open whether there is a sufficient difference in grade to allow us to assume that the present races of man may be considered as standing on different stages of the evolutionary series, whether we are justified in ascribing to civilized man a higher place in organization than to primitive man. In answering this question we must clearly distinguish between the influences of civilization and of race. A number of anatomical facts point to the conclusion that the races of Africa, Australia, and Melanesia are to a certain extent inferior to the races of Asia, America, and Europe. We find that on the average the size of the brain of the negroid races is less than the size of the brain of the other races; and the difference in favor of the mongoloid and white races is so great that we are justified in assuming a certain correlation between their mental ability and the increased size of their brain. At the same time it must be borne in mind that the variability of the mongoloid and white races on the one hand and of the negroid races on the other is so great that only a small number, comparatively speaking, of individuals belonging to the latter have brains smaller than any brains found among the former; and that, on the other hand, only a few individuals of the mongoloid races have brains so large that they would not occur at all among the black races. That is to say, the bulk of the two groups of races have brains of the same capacities, but individuals with heavy brains are proportionately more frequent among the mongoloid and white races than among the negroid races. Probably this difference in the size of the brain is accompanied by differences in structure, although no satisfactory information on this point is available. On the other hand, if we compare civilized people of any race with uncivilized people of the same race, we do not find any anatomical differences which would justify us in assuming any fundamental differences in mental constitution.

When we consider the same question from a purely psychological point of view, we recognize that one of the most fundamental traits which distinguish the human mind from the animal mind is common to all races of man. It is doubtful if any animal is able to form an abstract conception, such as that of number, or any conception of the abstract relations of phenomena. We find that this is done by all races of man. A developed language with grammatical categories presupposes the ability of expressing abstract relations, and, since every known language has grammatical structure, we must assume that the faculty of forming abstract ideas is a common property of man. It has often been pointed out that the concept of number is developed very differently among different peoples. While in most languages we find numeral systems based upon the 10, we find that certain tribes in Brazil, and others in Australia, have numeral systems based on the 3, or even on the 2, which involve the impossibility of

expressing high numbers. Although these numeral systems are very slightly developed as compared with our own, we must not forget that the abstract idea of number must be present among these people, because without it no method of counting is possible. It may be worth while to mention one or two other facts taken from the grammars of primitive people, which will make it clear that all grammar presupposes abstractions. The three personal pronouns—I, thou, and he—occur in all human languages. The underlying idea of these pronouns is the clear distinction between the self as speaker, the person or object spoken to, and that spoken of. We also find that nouns are classified in a great many ways in different languages. While all the older Indo-European languages classify nouns according to sex, other languages classify nouns as animate or inanimate, or as human and not human, etc. Activities are also classified in many different ways. It is at once clear that every classification of this kind involves the formation of an abstract idea. The processes of abstraction are the same in all languages, and they do not need any further discussion, except in so far as we may be inclined to value differently the systems of classification and the results of abstraction.

The question whether the power to inhibit impulses is the same in all races of man is not so easily answered. It is an impression obtained by many travelers, and also based upon experiences gained in our own country, that primitive man and the less educated have in common a lack of control of emotions; that they give way more readily to an impulse than civilized man and the highly educated. I believe that this conception is based largely upon the neglect to consider the occasions on which a strong control of impulses is demanded in various forms of society. What I mean will become clear when I call your attention to the often described power of endurance exhibited by Indian captives who undergo torture at the hands of their enemies. When we want to gain a true estimate of the power of primitive man to control impulses, we must not compare the control required on certain occasions among ourselves with the control exerted by primitive man on the same occasions. If, for instance, our social etiquette forbids the expression of feelings of personal discomfort and of anxiety, we must remember that personal etiquette among primitive men may not require any inhibition of the same kind. We must rather look for those occasions on which inhibition is required by the customs of primitive man. Such are, for instance, the numerous cases of taboo—that is, of prohibitions of the use of certain foods, or of the performance of certain kinds of work, which sometimes require a considerable amount of self-control. When an Eskimo community is on the point of starvation and their religious proscriptions forbid them to make use of the seals that are basking on the ice, the amount of self-control of the whole community which restrains them from killing these seals is certainly very great. Cases of this kind are very nu-

merous, and prove that primitive man has the ability to control his impulses, but that this control is exerted on occasions which depend upon the character of the social life of the people, and which do not coincide with the occasions on which we expect and require control of impulses.

The third point in which the mind of primitive man seems to differ from that of civilized man is in its power of choosing between perceptions and actions according to their value. On this power rests the whole domain of art and of ethics. An object or an action becomes of artistic value only when it is chosen from among other perceptions or other actions on account of its beauty. An action becomes moral only when it is chosen from among other possible actions on account of its ethical value. No matter how crude the standards of primitive man may be in regard to these two points, we recognize that all of them possess an art, and that all of them possess ethical standards. It may be that their art is quite contrary to our artistic feeling. It may be that their ethical standards outrage our moral code. We must clearly distinguish between the æsthetic and ethical codes and the existence of an æsthetic and ethical standard.

Our brief consideration of the phenomena of abstraction, of inhibition and of choice, leads, then, to the conclusion that these functions of the human mind are common to the whole of humanity. It may be well to state here that, according to our present method of considering biological and psychological phenomena, we must assume that these functions of the human mind have developed from lower conditions existing at a previous time, and that at one time there certainly must have been races and tribes in which the properties here described were not at all, or only slightly, developed; but it is also true that among the present races of man, no matter how primitive they may be in comparison with ourselves, these faculties are highly developed.

It is not impossible that the degree of development of these functions may differ somewhat among different types of man; but I do not believe that we are able at the present time to form a just valuation of the power of abstraction, of control, and of choice among different races. A comparison of their languages, customs, and activities suggests that these faculties may be unequally developed; but the differences are not sufficient to justify us in ascribing materially lower stages to some peoples and higher stages to others. The conclusions reached from these considerations are therefore, on the whole, negative. We are not inclined to consider the mental organization of different races of man as differing in fundamental points.

We next turn to a consideration of the second question propounded here, namely, to an investigation of the influence of the contents of the mind upon the formation of thoughts and actions. We will take these up in the same order in which we considered the previous question. We will first direct our attention to the phenomena of percep-

tion. It has been observed by many travelers that the senses of primitive man are remarkably well trained; that he is an excellent observer. The adeptness of the experienced hunter, who finds the tracks of his game where the eye of an European would not see the faintest indication, is an instance of this kind. While the power of perception of primitive man is excellent, it would seem that his power of logical interpretation of perceptions is deficient. I think it can be shown that the reason for this fact is not founded on any fundamental peculiarity of the mind of primitive man, but lies, rather, in the character of the ideas with which the new perception associates itself. In our own community a mass of observations and of thoughts is transmitted to the child. These thoughts are the result of careful observation and speculation of our present and of past generations; but they are transmitted to most individuals as traditional matter, much the same as folklore. The child associates new perceptions with this whole mass of traditional material, and interprets his observations by its means. I believe it is a mistake to assume that the interpretation made by each civilized individual is a complete logical process. We associate a phenomenon with a number of known facts, the interpretations of which are assumed as known, and we are satisfied with the reduction of a new fact to these previously known facts. For instance, if the average individual hears of the explosion of a previously unknown chemical, he is satisfied to reason that certain materials are known to have the property of exploding under proper conditions, and that consequently the unknown substance has the same quality. On the whole, I do not think that we should try to argue still further, and really try to give a full explanation of the causes of the explosion.

The difference in the mode of thought of primitive man and of civilized man seems to consist largely in the difference of character of the traditional material with which the new perception associates itself. The instruction given to the child of primitive man is not based on centuries of experimentation, but consists of the crude experience of generations. When a new experience enters the mind of primitive man, the same process which we observe among civilized men brings about an entirely different series of associations, and therefore results in a different type of explanation. A sudden explosion will associate itself in his mind, perhaps, with tales which he has heard in regard to the mythical history of the world, and consequently will be accompanied by superstitious fear. When we recognize that, neither among civilized men nor among primitive men, the average individual carries to completion the attempt at casual explanation of phenomena, but carries it only so far as to amalgamate it with other previously known facts, we recognize that the result of the whole process depends entirely upon the character of the traditional material. Herein lies the immense importance of folklore in determining the mode of thought. Herein lies particularly the enormous influence of current philosophic

opinion upon the masses of the people, and herein lies the influence of the dominant scientific theory upon the character of scientific work.

It would be in vain to try to understand the development of modern science without an intelligent understanding of modern philosophy; it would be in vain to try to understand the history of mediæval science without an intelligent knowledge of mediæval theology; and so it is in vain to try to understand primitive science without an intelligent knowledge of primitive mythology. Mythology, theology, and philosophy are different terms for the same influences which shape the current of human thought and which determine the character of the attempts of man to explain the phenomena of nature. To primitive man—who has been taught to consider the heavenly orbs as animate beings, who sees in every animal a being more powerful than man, to whom the mountains, trees, and stones are endowed with life—explanations of phenomena will suggest themselves entirely different from those to which we are accustomed, since we base our conclusions upon the existence of matter and force as bringing about the observed results. If we do not consider it possible to explain the whole range of phenomena as the result of matter and force alone, all our explanations of natural phenomena must take a different aspect.

In scientific inquiries we should always be clear in our own minds of the fact that we do not carry the analysis of any given phenomenon to completion; but that we always embody a number of hypotheses and theories in our explanations. In fact, if we were to do so, progress would hardly become possible, because every phenomenon would require an endless amount of time for thorough treatment. We are only too apt, however, to forget entirely the general, and, for most of us, purely traditional, theoretical basis, which is the foundation of our reasoning, and to assume that the result of our reasoning is absolute truth. In this we commit the same error that is committed, and has been committed, by all the less civilized peoples. They are more easily satisfied than we are at the present time, but they also assume as true the traditional element which enters into their explanations, and therefore accept as absolute truth the conclusions based on it. It is evident that the fewer the number of traditional elements that enter into our reasoning, and the clearer we endeavor to be in regard to the hypothetical part of our reasoning, the more logical will be our conclusions. There is an undoubted tendency in the advance of civilization to eliminate traditional elements, and to gain a clearer and clearer insight into the hypothetical basis of our reasoning. It is therefore not surprising that, with the advance of civilization, reasoning becomes more and more logical, not because each individual carries out his thought in a more logical manner, but because the traditional material which is handed down to each individual has been thought out and worked out more thoroughly and more carefully. While in primitive

civilization the traditional material is doubted and examined by only a very few individuals, the number of thinkers who try to free themselves from the fetters of tradition increases as civilization advances.

The influence of traditional material upon the life of man is not restricted to his thoughts, but manifests itself no less in his activities. The comparison between civilized man and primitive man in this respect is even more instructive than in the preceding case. A comparison between the modes of life of different nations, and particularly of civilized man and of primitive man, makes it clear that an enormous number of our actions are determined entirely by traditional associations. When we consider, for instance, the whole range of our daily life, we notice how strictly we are dependent upon tradition that can not be accounted for by any logical reasoning. We eat our three meals every day, and feel unhappy if we have to forego one of them. There is no physiological reason which demands three meals a day, and we find that many people are satisfied with two meals, while others enjoy four or even more. The range of animals and plants which we utilize for food is limited, and we have a decided aversion against eating dogs, or horses, or cats. There is certainly no objective reason for such aversion, since a great many people consider dogs and horses as dainties. When we consider fashions, the same becomes still more apparent. To appear in the fashions of our forefathers of two centuries ago would be entirely out of the question and would expose one to ridicule. The same is true of table manners. To smack one's lips is considered decidedly bad style, and may even excite feelings of disgust, while among the Indians, for instance, it would be considered as in exceedingly bad taste not to smack one's lips when one is invited to dinner, because it would suggest that the guest does not enjoy his dinner. The whole range of actions that are considered as proper and improper can not be explained by any logical reason, but are almost all entirely due to custom; that is to say, they are purely traditional. This is even true of customs which excite strong emotions, as, for instance, those produced by infractions of modesty.

While in the logical processes of the mind we find a decided tendency, with the development of civilization, to eliminate traditional elements, no such marked decrease in the force of traditional elements can be found in our activities. These are almost as much controlled by custom among ourselves as they are among primitive man. It is easily seen why this should be the case. The mental processes which enter into the development of judgments are based largely upon associations with previous judgments. I pointed out before that this process of association is the same among primitive men as among civilized men, and that the difference consists largely in the modification of the traditional material with which our new perceptions amalgamate. In the case of activities, the conditions are somewhat

different. Here tradition manifests itself in an action performed by the individual. The more frequently this action is repeated, the more firmly it will become established, and the less will be the conscious equivalent accompanying the action: so that customary actions which are of very frequent repetition become entirely unconscious. Hand in hand with this decrease of consciousness goes an increase in the emotional value of the omission of such activities, and still more of the performance of actions contrary to custom. A greater will power is required to inhibit an action which had become well established; and combined with this effort of the will power are feelings of intense displeasure.

This leads us to the third problem, which is closely associated with the difference between the manifestation of the power of civilized man and of primitive man to inhibit impulses. It is the question of choice as dependent upon value. It is evident from the preceding remarks that, on the whole, we value most highly what conforms to our previous actions. This does not imply that it must be identical with our previous actions, but it must be on the line of development of our previous actions. This is particularly true of ethical concepts. No action can find the approval of a people which is fundamentally opposed to its customs and traditions. Among ourselves it is considered proper and a matter of course to treat the old with respect, for children to look after the welfare of their aged parents; and not to do so would be considered base ingratitude. Among the Eskimo we find an entirely different standard. It is required of children to kill their parents when they have become so old as to be helpless and no longer of any use to the family or to the community. It would be considered a breach of filial duty not to kill the aged parent. Revolting though this custom may seem to us, it is founded on an ethical law of the Eskimo, which rests on the whole mass of traditional lore and custom.

One of the best examples of this kind is found in the relation between individuals belonging to different tribes. There are a number of primitive hordes to whom every stranger not a member of the horde is an enemy, and where it is right to damage the enemy to the best of one's power and ability, and if possible to kill him. This custom is founded largely on the idea of the solidarity of the horde, and of the feeling that it is the duty of every member of the horde to destroy all possible enemies. Therefore every person not a member of the horde must be considered as belonging to a class entirely distinct from the members of the horde, and is treated accordingly. We can trace the gradual broadening of the feeling of fellowship during the advance of civilization. The feeling of fellowship in the horde expands to the feeling of unity of the tribe, to a recognition of bonds established by a neighborhood of habitat, and further on to the feeling of fellowship among members of nations. This seems to be the limit of the ethical concept

of fellowship of man which we have reached at the present time. When we analyze the strong feeling of nationality which is so potent at the present time, we recognize that it consists largely in the idea of the preeminence of that community whose member we happen to be—in the preeminent value of its language, of its customs, and of its traditions, and in the belief that it is right to preserve its peculiarities and to impose them upon the rest of the world. The feeling of nationality as here expressed, and the feeling of solidarity of the horde, are of the same order, although modified by the gradual expansion of the idea of fellowship; but the ethical point of view which makes it justifiable at the present time to increase the well-being of one nation at the cost of another, the tendency to value one's own civilization as higher than that of the whole race of mankind, are the same as those which prompt the actions of primitive man, who considers every stranger as an enemy, and who is not satisfied until the enemy is killed. It is somewhat difficult for us to recognize that the value which we attribute to our own civilization is due to the fact that we participate in this civilization, and that it has been controlling all our actions since the time of our birth; but it is certainly conceivable that there may be other civilizations, based perhaps on different traditions and on a different equilibrium of emotion and reason, which are of no less value than ours, although it may be impossible for us to appreciate their values without having grown up under their influence. The general theory of valuation of human activities, as taught by anthropological research, teaches us a higher tolerance than the one which we now profess.

Our considerations make it probable that the wide differences between the manifestations of the human mind in various stages of culture may be due almost entirely to the form of individual experience, which is determined by the geographical and social environment of the individual. It would seem that, in different races, the organization of the mind is on the whole alike, and that the varieties of mind found in different races do not exceed, perhaps not even reach, the amount of normal individual variation in each race. It has been indicated that, notwithstanding this similarity in the form of individual mental processes, the expression of mental activity of a community tends to show a characteristic historical development. From a comparative study of these changes among the races of man is derived our theory of the general development of human culture. But the development of culture must not be confounded with the development of mind. Culture is an expression of the achievements of the mind, and shows the cumulative effects of the activities of many minds. But it is not an expression of the organization of the minds constituting the community, which may in no way differ from the minds of a community occupying a much more advanced stage of culture.



## TRAPS OF THE AMERICAN INDIANS—A STUDY IN PSYCHOLOGY AND INVENTION.

---

By OTIS T. MASON.

---

That unicorns may be betrayed with trees,  
And bears with glasses, elephants with holes,  
Lions with toils, and men with flatteries, \* \* \*  
Let me work;  
For I can give his humor the true bent,  
And I will bring him to the Capitol.

—*Julius Cæsar*, II, 1.

### MEANING OF THE TERM AMERICAN.

America, in this connection, embraces all of the Western Hemisphere visited by the native tribes in their activities associated with the animal kingdom. It might be allowed to exclude a small number of frozen or elevated or desert regions untrodden by human feet, were it not for the fact that most of these were the resorts of zoomorphic gods, creatures of the aboriginal imagination. The name America must in this study include also those oceanic meadows stretching out from the continents, whereon were nourished innumerable creatures, which dominated the activities of the littoral tribes.

### DEFINITION OF THE TERM TRAP.

A trap is an invention for the purpose of inducing animals to commit incarceration, self-arrest, or suicide. In the simplest traps the automatism is solely on the part of the animal, but in the highest forms automatic action of the most delicate sort is seen in the traps themselves, involving the harnessing of some natural force, current, weight, spring, and so on, to do man's work.

In capturing animals by the simplest methods they are merely taken with the hand as in gathering fruits. By a second step they are harvested with devices—scoop nets, dippers, seines, hooks that are substitutes for the crooked finger, reatas, dulls, bolas, and many more. A third step leads to active slaughter with clubs for bruising, knives and axes for cutting and hacking, and with a thousand and one imple-

ments for piercing and retrieving. In these the hunters are present and active, making war on the animal.

In the matter of automatism there is no great gulf between the trapper and the hunter. At both ends and in the middle of the trap's activity the man may be present, but not to the victim. Not waiting for the victim to go to its doom of its own will, the hunter, having set his trap, proceeds to entice and compel the game. He has learned to imitate to perfection the noises of birds and beasts—it may be of those he is hunting, of others hunted by them, or their enemies. He knows the smells that are agreeable and the dainty foods most liked. On the contrary, he also knows how to allay suspicions in one direction, to arouse them in another—always with the trap in his mind.

The action of the trap itself is also frequently assisted by the hunter out of sight. He releases the pent-up force of gravity, of elasticity.

Finally, the result of the trap's action is to hand the victim over to the hunter to carry away or to kill. Often the trap does the killing outright, and the result is raw material for the elaborative industries; but in other cases the hunter must be near by to give the coup de grâce. The instances are many where the victim must be dispatched at once, or the trap will be destroyed and the result lost.

#### THE TRAP AS AN INVENTION.

As intimated, the trap teaches the whole lesson of invention. At first it is something that the animal unwittingly treads on (Middle Low German, *treppen*, to tread; *tramp* is a kindred word). At last it is a combination of movement and obstruction, of release and execution, which vies in delicacy with the most destructive weapons. Gravity and elasticity are harnessed by ingenious mechanical combinations.

#### THE TERM PSYCHOLOGY.

In this paper the term "psychology" stands for all those mental processes that are caused and developed by trapping. There is the mental activity of the animal and that of the man. The trap itself is an invention in which are embodied most careful studies in animal mentation and habits. The hunter must know for each species its food, its likes and dislikes. A trap in this connection is strategy. Inasmuch as each species of animals has its own idiosyncrasies, and as the number of species was unlimited, the pedagogic influence of this class of inventions must have been exalting to a high degree for the primitive tribes.

The varieties of execution to be done by the trap were very great. It had to impound or encage, or to seize by the head, horns, limbs, gills; to maim, crush, slash, brain, impale, poison, and so on, as though

it had reason—the thought of the hunter had to be locked up in its parts ready to spring at a touch. As population increased, wants became more varied and animals became more scarce, more intellectual and wary. If any reader of this may himself have been a trapper he will remember the scrupulous care with which he proceeded at every point, to make the parts stable or unstable, to choose out of innumerable places one that to a careful weighing of a thousand indications seemed best, to set the trap in the fittest manner, and at last to cover his tracks so that the most wary creature would not have the slightest suspicion.

To catch a fox it was necessary to win its confidence, and this the savage knew. So he prepared a trap that was perfectly harmless, and let Reynard walk about over the ashes or fresh earth or chaff, picking up dainty bits until all suspicion was removed. Then was the time to conceal the trap. But all vestiges of human hand or foot must be removed, and the apparatus must be cleaned and smoked most effectually.

#### PARTS OF TRAPS.

The trap has two classes of parts, the working part and the mechanical, manual, animal part. The victim finds itself in a pound, deadfall,

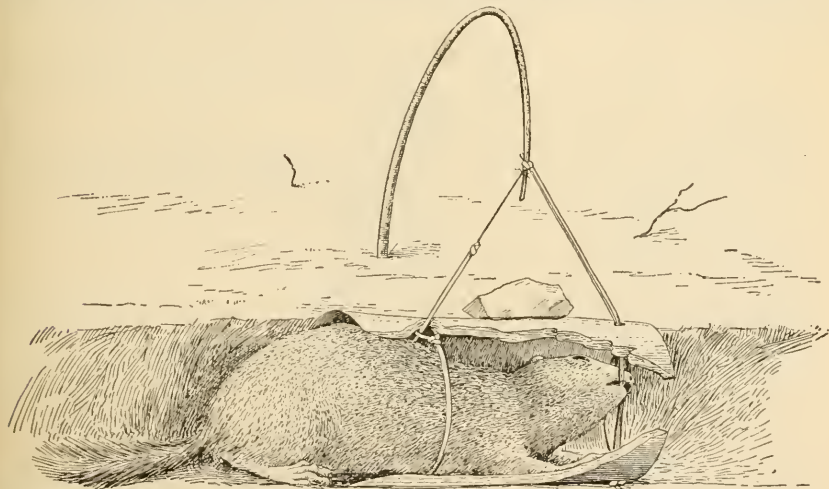

FIG. 1.—Marmot trap.

cage, hole, box, toil, noose, or jaw; on hook, gorge, pale, or knife, and so on. This dangerous element, to repeat, may not need any accessories. The fish swims into a fyke, the animal walks into a pit or pound, the bird or climbing animal finds itself in a cage with ratcheted entrance to prevent egress; that is all.

In a higher stage of invention, where the forces of gravity and elasticity are invoked to do the incarceration, arrest, or execution,

there has to be found between the lure and the execution a host of devices, and these form an ascending series of complexities. The simplest of these intermediary inventions is an unstable prop or support of some kind; the slightest pull at a bait removes the ticklish thing, and weight or noose, or other deadly part, is set free. The trigger and the catch are more complicated and varied; the secret of them all, however, is that an unstable catch is released by the animal in passing, in prying curiosity, in gnawing, or in rubbing; this is connected by means of sticks and strings to the last release, since the operation of releasing is in connection with the device in which the force is confined and by which the work is to be done. In the highest forms of weight traps and spring traps there are veritable machines, since they change the direction and effect of motion. It is on these that most ingenuity has been expended, and in them is exhibited that wonderful threefold play of working force, work to be done, and processes of reaching the end. Variations in the materials utilized will play no mean part, also, in a continent covering all zones save the antarctic, all elevations at which man can live, and all varieties of vegetal phenomena growing out of temperature and rainfall. To proceed with some order it will be necessary to divide the Western Hemisphere into convenient culture areas. The following will serve for a provisional list:

*American culture areas.*

Areas.	Peoples.
1. Arctic .....	Eskimo.
2. Canadian.....	Athapasean.
3. Atlantic slope.....	Algonquian-Iroquois.
4. Mississippi Valley.....	Siouan.
5. Louisiana or Gulf .....	Muskhogeian.
6. Southeastern Alaska.....	Haida-Koluschan.
7. Columbian region.....	Salish-Chinookan.
8. Interior basin.....	Shoshonean.
9. California region.....	Very mixed stocks.
10. Pueblo region.....	Tanoan-Tewan and Sonoran.
11. Middle American .....	Nahua-Mayan.
12. Cordilleran region.....	Chibcha-Kechuan.
13. Antillean region .....	Arawak-Caribbean.
14. Upper Amazonian.....	Jivaro, Peba, Puno, etc.
15. Eastern Brazilian region.....	Tupi-Guarani, Tapuya.
16. Mato Grosso and southward.....	Mixed people of Brazilian and Andean types.
17. Argentina-Patagonian region.....	Chaco, Pampean, and Patagonian stocks.
18. Fuegian region.....	Aliculuf, Ona, and Yahgan.

The inquiry will not be raised here whether the traps not made of metal and found in the hands of the American savages are entirely aboriginal, or whether there has been acculturation. A good knowledge of the traps as they exist or existed will go far toward settling the question of origin.

## CLASSIFICATION OF TRAPS.

Traps are variously classified according to the concept in the student's mind. If it be the natural element in which they work, there will be land traps for mammals, birds, reptiles, and invertebrates; water traps for mammals, birds, reptiles, fishes, and invertebrates; and air traps for birds and insects.

With reference to their parts, either mechanical or efficient, there are a multitude of names which will appear in a separate vocabulary. In the setting they are man set, self-set, ever-set, and victim-set.

For the purpose of this paper traps may be divided into three groups, namely: (A) Inclosing, (B) arresting, (C) killing. In each of these we may begin with the simpler forms—those with the least mechanism—and end with those that are more intricate.

*A.—Inclosing traps.*

- (a) Pen—dam, pound, fyke.
- (b) Cage—coop, pocket, cone, fish trap.
- (c) Pit—pitfalls.
- (d) Door—with trigger, fall cage, or fall door.

*B.—Arresting traps.*

- (e) Mesh—gill, toils, ratchet.
- (f) Set hook—set line, gorge, trawl.
- (g) Noose—snare, springe, fall snare, trawl snare.
- (h) Clutch—bird lime, mechanical jaws.

*C.—Killing traps.*

- (i) Weight—fall, dead fall.
- (k) Point—impaling, stomach, missile.
- (l) Edge—wolf knife, braining knife.

## A.—INCLOSING TRAPS.

Inclosing traps are those which imprison the victim, most of them without doing any further bodily harm, though there may be added to these some other devices which will injure or kill. There are four kinds of inclosing traps: (a) Pen traps, (b) cage traps, (c) pit traps, (d) door traps.

(a) *Pen traps.*—These include pounds or corrals on land, and dams, fish pens, and fykes in the water, the idea being simply to inclose. Traps of this sort have no tops and therefore are not useful for birds. In connection with other forms, small inclosures are used to surround the bait and to guide the victim in a certain direction. How the animal gets in, how it is kept in, and what is done to it afterwards will decide whether the pound is a trap or a corral or whether it is a reservoir, an abattoir, or a domesticating device. The simplest form of pound is of brush or reeds, and confines whatever enters, large or small; but the perfect form has interstices carefully adapted to retain certain species

and to allow others to escape, or holds the adult individual in and lets the small and young out. The savage tribes, further, could make movable walls of reeds and long nets. Indeed, the great impounding nets are the last word in the series. Add to the pound an entrance and there begins another set of inventions around the notion of shutting. A gateway may be closed by nature or by device. The tide falls and leaves aquatic creatures imprisoned. Animals get under some obstacle and can not surmount it. They corral themselves. A gateway may be guarded by sentinels also, but gates may be intentionally shut or a pound-shaped barrier be set up, so that the return of those which pass in is impossible. Most pounds, whether in water or on land, have

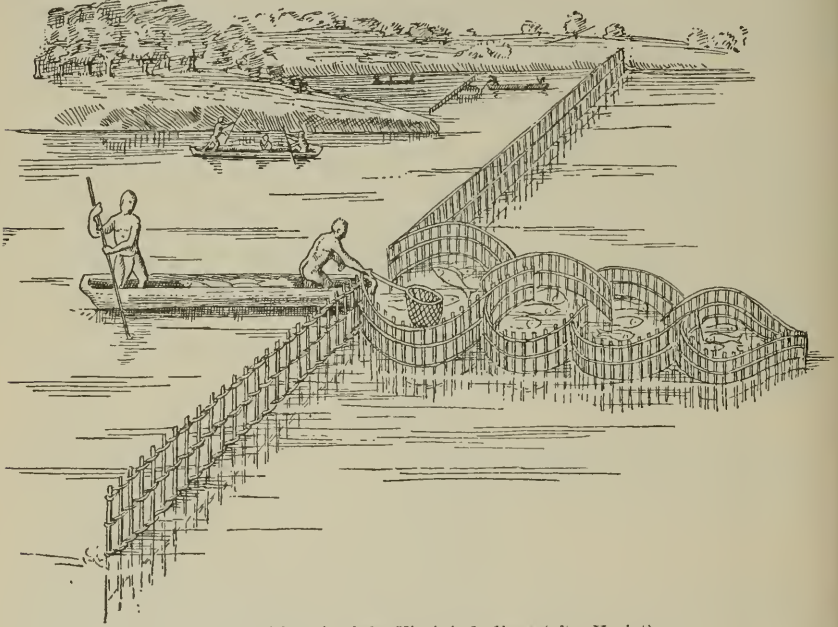

FIG. 2.—Fish weir of the Virginia Indians (after Harriot).

some natural or artificial lane for conducting the game to the gateway. On either side may be precipices, trees with ropes or wattles between wing nets, or something of the kind, along which animals pursue their natural course and are lured or driven to the pen (fig. 2).

(b) *Cage traps.*—In this class must be grouped all forms of coops and strong house traps on land, and a great variety of cones, pockets, and fish traps in the waters. All of these are designed for climbing, flying, or swimming creatures. The cage or coop trap, completely inclosed on every side, is a step in advance of an open pen, whether on land or in the water. The majority of cage traps have funnel-shaped entrances, into which the animal passes easily and unrestrained, but exit is prevented by means of a pointed strip of wood or other substance acting as a ratchet; or in the case of nets, the small end of

the funnel consists of a series of string gates which the animal passes, and these close the mouth of the net so as to prevent escape (fig. 3).

Among the Eskimo a unique contrivance for catching foxes was a net which was made to be set around a burrow, in the corners of which were long pockets, opening wide into the net, but gradually contracting until the fox could go no farther. Endeavoring to turn back, it became hopelessly entangled and died of fright and cold.

(c) *Pits*.—The digging of pits was not common in America before the discovery, owing to the lack of metallic excavating tools. Pits partially dug out and partially built up were seen here and there as a blind for the hunter, who concealed himself therein. Boas, quoting Lyon, describes an Eskimo fox trap in the snow into which the animal jumped and was unable to extricate itself.

The central Eskimo, according to the same authority, dig a wolf trap in the snow and cover it with a slab of snow on which the bait is laid. The wolf breaks through the roof, and as the bottom of the pit is too narrow to afford him jumping room, he is caught.

The Cree, in the Saskatchewan country, place at the end of their deer drives a log of wood, and on the inner side make an excavation sufficiently deep to prevent the animal from leaping back.

Pitfalls are said to have been used by the Indians of Massachusetts. They are described as oval in shape, 3 rods long and 15 feet deep.

The Concow Indians of California are said to catch grasshoppers for food by driving them into pits. The Achomawi, or Pit River Indians, dug deer pitfalls 10 or 12 feet deep by means of sticks, and carried the earth away in baskets. In southern Brazil, also, wild beasts were caught in pits dug for that purpose and covered with leaves.

(d) *Door traps*.—The last form of inclosing trap to be mentioned here is also the most mechanical; it includes those in which a door falls and incloses the animal, or in which a cage, one side of which is held up by an unstable prop, falls and incloses the victim.

Parry describes a small house trap, made of ice and used by the Eskimo for foxes, at one end of which was a door made of the same material, to slide up and down in a groove. This door was sustained by a line which passed over the roof and was caught inside on a hook

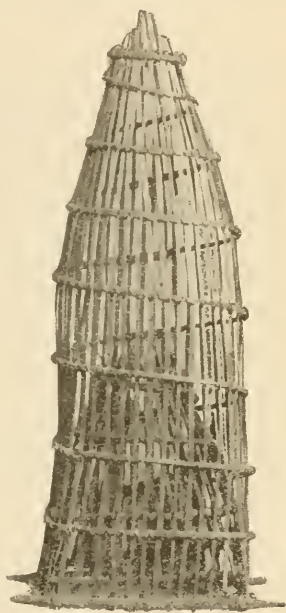

FIG. 3.—Fish trap.

of ice by means of a loose grommet to which the bait was fastened. The fox, pulling at the bait, released the door of ice and found itself in prison.

Crantz describes a house trap used by the Greenlanders in which a broad stone forms the movable door. I have seen a trap of similar mechanism used by folks in eastern United States, in which a cage or basket is propped up with a loop of splint; this, pulled inside by the animal tugging at the bait, brings down the cage over the victim. Doubtless this form of imprisoning animals designed to be taken alive was quite well spread over the continent.

#### B.—ARRESTING TRAPS.

The arresting traps are designed to seize the victim.

(e) *Mesh nets*.—The mesh net is based on the fact that animals, by the conformation of their bodies or by the set of the hair, feathers, or gills, may ratchet themselves. To this class belong "toils" for land animals, trammels and gill nets for aquatic animals.

Among the archaeological treasures of our National Museum are many net sinkers, which would lead to the conclusion that netting is an old art among the aborigines. The majority of netting devices are for aquatic animals, but tribes on the coast of British Columbia suspend nets between poles in order to capture migratory geese and ducks. The Eskimo make nets of sinew, of rawhide, and of baleen; these are set across the rivers in open water, but more ingeniously under the ice by means of holes cut at such distances apart as to enable the fishermen to draw the net out and in.

A device somewhat in the nature of this is used by the Eskimo of Point Barrow for catching seals; four holes are drilled through the ice about a breathing hole; from these a net is set under the breathing hole, the lines being worked through the four corners of the space; the net is hung under the ice, and the seal coming to breathe is entangled therein.

Gill nets are set for seal after the ice forms along the shore. Murdoch reports that smaller seals are captured also in meshing nets of rawhide set along the shore in shallow water; he thinks that the meshing nets in northern Alaska came from Siberia.

Elliott illustrates Eskimo women catching salmon in a gill net consisting of a pole and a triangular net attached. The pole rests on a stone at the water line, while the net sinks in the water; as soon as a fish strikes, the women lift the pole, extricate the fish, and reset the net.

Mesh fishing is also quite common among the Athapascan tribes, both on the Yukon and on the Mackenzie. Charlevoix states that in St. Francis River, Canada, the Indians made holes in the ice, through which they let nets five or six fathoms long; he also describes the taking of beaver by means of nets.



(*f*) *Set hooks*.—These may be employed on land or in the water. A toggle or gorge may be so baited or placed that a duck or a goose, by diving and swallowing it, may be held under the water and drowned. A single hook may be set for vermin, or baited and left in the water, especially for large fish; for the smaller fish, the trawl or trot line holding several hooks may be stretched across a body of water, and thus the game may be secured in the absence of the fisherman.

In one sense, many hooks used in taking birds and fishes are traps. They are baited and cast into the water or placed in such position on land that the hunter is out of sight. A line is attached to hooks of this kind, one end of which may be held in the hands of the hunter or tied to a buoy or other signal device.

It is interesting to note that fishhooks are not found in many American areas—large regions are entirely devoid of them, and in ancient mounds and works such relics are wanting. No picture of a fishhook is seen in any Mexican or Maya codex, and Von den Steinen notes the entire absence of fishhooks from large places on the affluents of the Amazon. The simplest form of this class of devices was seen by Lumholtz among the Tarahumari in northern Mexico; they catch blackbirds by tying corn on a snare of pita fiber hidden under the ground; the bird swallows the kernel, which becomes toggled in its œsophagus, and can not eject it.

In the order of complexity—a removal from the mere action of hand hooks for capture—hook traps may be divided into the following classes: The seed on a string; the gorge; hook at the end of a string, squid hook; baited hooks; compound hooks; barbed hooks; and automatic hooks.

(*g*) *Noose*.—This is a most interesting class of traps. A string or thong or rope, or a bit of whalebone and sinew, may have one end looped around itself so as to slip with perfect ease; the other end will be fastened to some object. This noose may be so placed that the animal will run its head or its foot into it and be caught; or it may be attached to a bent sapling or some form of spring which is held down by a device, to be liberated by the animal coming to seize the bait or lure. In order to prevent the animal from gnawing the snare, perforated sticks may be suspended just over the knot, thus making a very complicated device. The noose may be used in the air for birds on the wing, on the land in many ways, and sparingly in the water.

Boas says that among the central Eskimo waterfowl of all descriptions are caught in abundance in whalebone nooses fastened to a long whalebone line or to a thong. Hares, ermines, and lemmings are also taken in whalebone snares. E. W. Nelson describes a noose for catching Parry's marmot, which involves a form of release mentioned also as used among the Iroquois. The victim enters the leadway as usual,

and instead of pulling at the bait to release the spring, it gnaws in two a string which holds the snare down and which has something on it appetizing to the animal. In the Iroquois rabbit trap the string is steeped in salt (fig. 1).

The simplest nooses at Point Barrow are made of baleen and set around where fine gravel has been placed to attract the birds. Accounts are also given of nooses of whalebone set in water along the shores where ducks dive for their favorite plants, and which catch the birds by the neck. This reminds one of the use of the mesh net for the same purpose in California. From Nelson and other observers among the Eskimo, and from the examination of collections in the museums, it is learned that the methods and places of setting a noose are limited only by the habits of the different animals.

In the Mackenzie River country, and wherever the Hudson Bay Company's people have prosecuted their work, the snare and the springe are very commonly employed. Even reindeer and moose are strangled by means of snares set in their way. Father Morice figures in the Transactions of the Canadian Institute, 1894, a great variety of applications of the noose.

In Wood's New England Canaan we have the quaintest description of a New England trap:

"The Salvages take these in trappes made of their naturall Hempe which they place in the earthe where they fell a tree for browse and when he roundes the tree for the browse if hee tread on the trap he is horsed up by the legg by means of a pole that starts up and catcheth him."<sup>a</sup>

The gentleman of Elvas<sup>b</sup> gives the following description of the trap among the Autiamgue tribes:

"With great springes which lifted up their feet from the ground; and the snare was made with a strong string, whereunto was fastened a knot of a cane, which ran close about the neck of the conie, because they should not gnaw the string."

Teit, in his account of the Thompson River tribe,<sup>c</sup> describes deer fences and springes used in catching large and small animals. Mrs. Allison describes snares for catching deer and birds in the same region. This custom prevails also in California among many tribes described by Frost and Powers. Zuñi boys catch blackbirds with snares made of horsehair fastened to a rope; these snares are laid on the ground and seeds placed between. When the birds alight they put their feet into the snare and are drawn up and captured. The older Zuñis drive sunflower stalks into the ground and fasten a noose on the top. When a hawk, watching for field mice, alights on the

<sup>a</sup>New England Prospect, Prince Society; Boston, 1883, p. 202.

<sup>b</sup>"Hakluyt, Voyages, Vol. III, p. 114.

<sup>c</sup>Memoirs of the American Museum of Natural History, Anthropology, Vol. II, pp. 247-249, figs. 228, 229.

stalks, its feet are ensnared; being unable to rise, the hawk remains stupidly on its perch and allows itself to be captured.

The Tarahumari of Chihuahua are very ingenious in trapping rats, gophers, and deer. The ancient inhabitants of Copan caught quetzal birds in snares, and having plucked their beautiful feathers, set them at liberty again. In southern Brazil birds were snared by the feet, by the neck, and by the body. The Fuegians also use baleen nooses, which are set hidden in the grass for the purpose of catching partridges and other birds.

(h) *Clutching devices* are best exemplified by bird lime. The ordinary jaw trap of the hunters may be placed in this class; the common steel rat trap is a good example. It is possible that spring nets may have been used in certain parts of America before the discovery, but the principle involved in the metallic clutching traps was not known.

#### C.—KILLING TRAPS.

The principles involved in killing traps are those mentioned under "hunting," as crushing, piercing, and cutting.

(i) *Weight trap*.—The simplest form of killing trap is the dead fall, in which a heavy weight drops suddenly upon the animal, destroying its life. The most interesting parts of the dead fall are the inventions for securing an unstable support of the weight and for releasing this support by means of the trigger or bait contrivance. There are few separate accessory appliances to the dead fall, since the animal is slain outright.

The fall trap was found in several of the areas mentioned. Essentially, in its least complex form, it consists of five parts: A heavy weight to crush the animal, a fixed support (perhaps a stake in the ground), an unstable support on which the weight rests, a catch which prevents the weight from falling until the bait is nibbled or the string pulled, and, lastly, the trigger itself. The Central and Western Eskimo form of dead fall has a slab of ice as a crushing weight. The Hudson Bay Company's native trappers have a great variety of this particular type.

Maximilian figures a dead fall used for bears in Pennsylvania. The animal walks between two logs. Above are two logs fastened firmly together. These are held up by a crossbar supported between two sticks. A lever attached to the log passes over the crossbar and is held down at either end in a ratchet, where there is a bait. The bear crouches between the logs, pulls the trigger, and releases the lever, which flies up and lets the ring that supports the fall slip off; then comes the tragedy.

Similar traps are noted in British Columbia and throughout the southwestern country, but not in middle America or in South America. The Hopi of Arizona, according to Dr. Hough, have two very primi-

tive forms of dead fall; one, for foxes, consists of a heavy stone slab worked between two upright slabs for wings. One end of the prop rests above against the stone; the other end rests on a cobblestone beneath. The least touch of the prop rocks the cobblestone and lets the weight down upon the fox. In another form, used for taking birds, the box and the fall, or stone slab, are similar. The release consists of the following parts: First, the upright and the notched catch, precisely as in the figure-4 traps. To the bottom of the notched catch a short string is tied, having at the other end a small wooden toggle, which is held by a little rod resting against it and caught at its other extremity in the grains of the sandstone slab. The least touch overcomes the friction between the trigger and the slab. This sets free the toggle, which unwinds from the post, the hook catch flies up, and the weight falls.

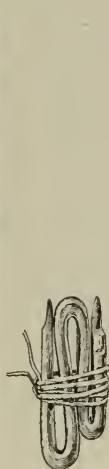

FIG.

FIG. 4.—Game spits.

(k) *Point traps* of the highest order were not common in America; that is, the use of arbalest or bow for the purpose of driving an arrow or bolt into the victim or for impaling, or the use of sharpened sticks in the pathway of land animals; but the throwing in the way of carnivorous animals of sharpened whalebone splinters wrapped in fat was practiced.

Bancroft mentions a bear trap, used by the Aleuts, consisting of a board 2 feet square and 2 inches thick, furnished with barbed spikes, which was placed in Bruin's path and covered with dust. The unsuspecting stepped upon the smooth surface, when his foot sank and was pierced by one of the barbed hooks. Maddened with pain, he put forth another foot to

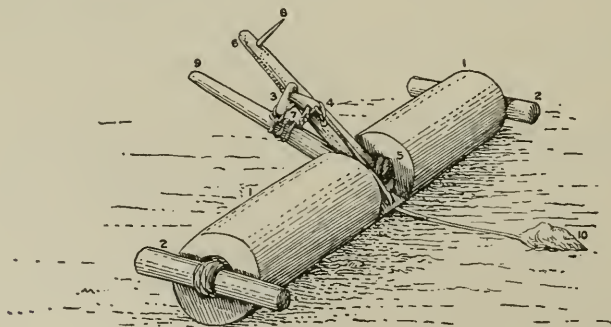

FIG. 5.—Fox or wolf trap with sinew spring.

assist in pulling the first away, when that, too, was caught. When all four of the feet were spiked to the board the beast fell over on its back and its career was soon ended by the hunter.

The wolf bait, made of a piece of whalebone sharpened at both ends and doubled up, has been mentioned by Boas, and examples of the same device were brought to the National Museum by Nelson from St. Michael, Alaska (fig. 4).

Lumbholtz says that the Tarahumari catch deer by putting sharpened sticks in the track and stampeding the animals with dogs.

(l) *Edge traps.*—There were in America two forms of knife or cutting traps of the most ingenious character. One may be called the wolf knife. A sharpened blade was inclosed in a frozen mass of fat and stuck up in a block of ice. The wolf, licking the fat, cut its tongue. The taste of the blood infuriated the animal, so that by licking the knife more it caused a larger flow of blood. All the other members of the pack were attracted to the same spot, devouring one another for the sake of the blood, till all were destroyed.

Another form of edge trap is found in Alaska, where the blades are attached to one end of a lever, the other end of which is inclosed in a torsion spring of rawhide. The animal stops to pick the bait, pulls the trigger, and releases the unstable hook catch; the knives fly over and the victim is brained (fig. 5).



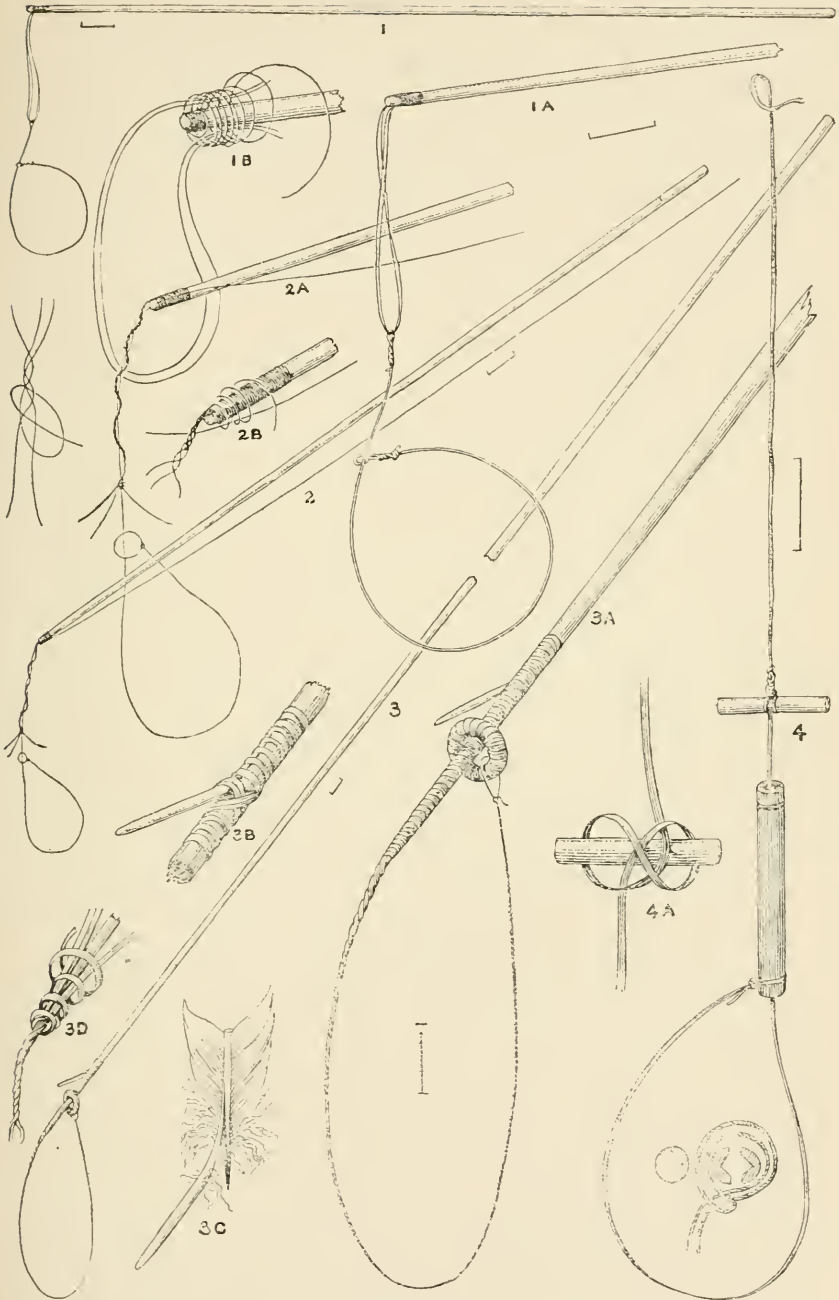

TRAPS OF THE AMERICAN INDIANS. STEPS OF AUTOMATISM IN THE GRASPING DEVICE.

1, Common dull; 2, dull and tickler; 3, dull and ratchet; 4, complex moose trap.





## THE ABBOTT COLLECTION FROM THE ANDAMAN ISLANDS.

---

By LIEUT. W. E. SAFFORD, U. S. N.

---

The Andaman Archipelago is a small group of densely wooded islands about 1,760 square miles in area, situated in the Bay of Bengal near the meridian of 93° east longitude and between the tenth and fifteenth parallels of north latitude. The group lies about 180 miles southwest of Cape Negrais, Burma, and is separated from the Nicobar Islands, lying to the southward, by a channel 60 miles wide.

Great Andaman, the largest and most important member of the group, is about 140 miles long. Though apparently a single island, it is divided by narrow channels, or creeks, into several parts, the principal of which are known as North Andaman, Middle Andaman, and South Andaman. A short distance to the eastward of South Andaman lies a group of islands known as the "Archipelago;" to the southward, separated from South Andaman by MacPherson Strait, is Rutland Island; and south of this are Cinque Islands.

Narcondam and Barren Islands are outlying volcanic islets, the latter situated about 45 sea miles east of the northern part of the "Archipelago," and between Great Andaman and the Nicobar group lies Little Andaman.

Dr. W. L. Abbott, accompanied by Mr. C. Boden Kloss, visited the Andamans in January, 1901, collecting objects of ethnological interest, together with specimens of mammals, birds, and reptiles. He first touched at Barren Island, which he found overrun with goats, descendants of animals left there by the English officials of Port Blair. Forests have spread over the outer slopes of the volcano, which forms the island, and the slopes of the crater are partially covered with jungle. The cone in its interior and the lava streams on the floor are still devoid of vegetation. The island is uninhabited. After collecting specimens of rodents and of birds on Barren Island he proceeded to the "Archipelago," dropping anchor in Kwantung Straits near Henry Lawrence Island.

At Port Blair, on South Andaman, where the English have a convict settlement, and a "refuge house" for the benefit of shipwrecked sailors, he saw the native Andamanese for the first time. In a letter accom-

panying his notes on the collections made by him, Dr. Abbott says that a small tribe of hostile Andamanese wanders about South Andaman, and another one inhabits the south end of Rutland Island.

From Port Blair Dr. Abbott went to MacPherson Strait, dropping anchor between South Andaman and Rutland Island. Here he set his traps and caught a *Paradoxurus*, or "musang," an animal belonging to the civet-cat family, the bones of which the natives frequently make into necklaces. Dr. Abbott was struck by the absence of squirrels, which on the neighboring coasts of the continent and on many islands adjacent to it are abundant. The next stoppage was at North Cinque Island, whence he went to Little Andaman, anchoring off the mouth of Bumila Creek, at the northern extremity. The natives were friendly, but brought off to the ship with them "quantities of a beastly little fly that made life well-nigh unendurable." The commissioner at Point Blair had warned Dr. Abbott not to touch at Little Andaman except at Bumila Creek, as the natives elsewhere are more or less hostile, "and the first warning of a hostile Andamanese is an arrow whizzing past you or sticking in your body, while it is utterly impossible to see the little black men in the dark forest."

Dr. Abbott's collection of ethnological material includes a number of interesting specimens from South Andaman Island, illustrating the arts and customs of the Bo-jig-ngi-ii tribe. He calls attention to the decided difference between these articles and those collected by him at Rutland Island, only 15 miles south of Port Blair. Mr. E. H. Man, who has written many interesting papers on the Andamanese in the Journal of the Anthropological Institute, had retired from the Government service shortly before Dr. Abbott's visit. At that time the station at Port Blair was in charge of Mr. Vaux, who received his party and looked after them during their stay.

#### HISTORY.

From the earliest times the inhabitants of the Andaman Islands have been considered one of the most primitive and most savage races on the face of the earth. Fabulous stories have been told of them by early writers. Accounts of their alleged cannibalism are found in Chinese writings. It is thought that they were included by Ptolemy in the "*insulæ bonæ fortunæ*" described by him, the inhabitants of which were "anthropophagi, whose heads do grow beneath their shoulders;" and other writers have referred to the natives as having *tails like horses*. Whatever may have been the exaggerations of these early accounts of the personal attributes of the Andamanese, it is undoubtedly true that they were cruel and merciless savages, who destroyed all those so unfortunate as to be cast upon their shores. Their own heads were not situated beneath their shoulders, but they did frequently wear the skulls of departed relatives suspended by a band around the neck (see Pl. I, figs. 8 and 9); and their "horse-like

tails" were appendages on their belts of pandanus leaves, the nearest approach to clothing worn by them (Pl. I, figs. 22 and 23), the men not attempting to conceal their nakedness, but the women through modesty suspending a few green leaves from their belts in the form of a very small apron (Pl. I, fig. 16).

Dr. Abbott reports that at the time of his visit there were over 10,000 convicts at Port Blair. By means of presents of cloth, food, iron, and other things dear to the savage heart, the officials cultivate friendly relations with the natives, who in return render the Government the most important services in keeping the convicts in check. Indeed, without the aid of the natives the station would have to be abandoned. "The convicts," Dr. Abbott writes, "are naturally a pretty bad lot. Were it not for their fear of the Andamanese escape would be very frequent, and in the vast, dense forests of the islands recapture would be almost impossible; but with the Andamanese recapture is certain. It is great fun for the little black men, who do not hesitate to kill the runaway if he makes any resistance."

#### ENVIRONMENT.

The islands are watered by numerous streams at the mouths of which, as on all tropical shores, are great areas covered with a tangled growth of mangroves and their allies, flooded at high tide, but exposed at low water. From the slimy, muddy tracts thus uncovered, over which crabs and other shellfish crawl and the strange little air-breathing fish, *Periophthalmi*, hop about, offensive odors rise and malarial gases are exhaled. Elsewhere along the coast there are stretches of white sandy beach upon which the natives wade, visiting the fringing reefs for crustaceans, mollusks, and other marine animals used by them for food. It is interesting to note that, with the exception of a few spots, evidently planted by the early colonists, cocoanuts do not occur in the Andamans, and this is especially remarkable from the fact that the conditions are favorable for their propagation.

The interior is taken up with an almost impenetrable forest of lofty trees, many of which yield fruit, fiber suitable for making nets and cordage, resins, and excellent hardwood.

Unlike the islands lying eastward of the Malay Peninsula, the Andamans are separated from the continent by deep water. It is not surprising, therefore, that the fauna should be poor in mammals. With the exception of bats and, perhaps, a tree shrew, all of the mammals of the group may possibly have been introduced through human agency. The wild pig, *Sus andamanensis*, a small species, of which the full-grown boars weigh about 90 pounds, is allied to forms on the mainland and in Sumatra. The palm cat, *Paradoxurus tyleri*, an animal allied to the civets, may have escaped from vessels visiting the islands or wrecked there, and the rats and shrews were brought thither by junks.

## THE ANDAMANESE.

The origin of the Andamanese has long been an interesting problem to anthropologists. From the observations of Mr. E. H. Man, who, more than any other, has made the race a study, it appears that the Andamanese are Negritos and not Papuans. They are well made and well proportioned. Their skulls are brachycephalic (see Plate I, fig. 8), and very few cases of prognathism have been observed. Their lips are not thick, their profiles are good, and they have no peculiar odor like that which is found in the African race. Their extremities are small, but the heel projects slightly to the rear. From measurements of 48 men and 41 women, made by Mr. Man, it was found that the average height of the men was 4 feet 10 $\frac{3}{4}$  inches, of the women, 4 feet 7 $\frac{1}{4}$  inches, while the average weights were 98 $\frac{1}{2}$  pounds and 93 $\frac{1}{4}$  pounds, respectively. The maximum height of the males measured was 5 feet 4 $\frac{1}{4}$  inches, of the female 4 feet 11 $\frac{1}{2}$  inches, and the minimum heights were 4 feet 5 $\frac{3}{4}$  inches and 4 feet 4 inches, respectively. The color of the skin of the Andamanese is variable. It is generally bronze, or dark copper color; often the color of soot, and even quite black. Their hair is woolly, but its cross section is not always elliptical. It is a common practice for both sexes to shave the head. Boys attain puberty at the age of 16 years and girls at the age of 15. The average length of life is said to be 22 years. Adult women have a considerable development of adipose tissue in the region of the pelvis, but it is not excessive. Laughter is frequent and often immoderate. In a letter to the Smithsonian Institution, Doctor Abbott says: "We liked the Andamanese very much; they seem such a happy, jolly lot of little folk." And, of the inhabitants of Little Andaman, he says: "These were a happy, merry, little people, infantile both in their looks and behavior. They are without the rank smell of the negro. The girls are frequently pretty when young. They are the very blackest people I have ever seen." Of the natives near the settlement of Port Blair, he says: "Unfortunately they are dying out. Contact with civilization is making the women barren, and there are comparatively few children. In Little Andaman, which is in statu quo ante, they are in their original condition and are not dying out."

Whatever may have been the theories advanced to account for the presence of these Negritos in the Bay of Bengal, so entirely unlike any of their immediate neighbors, says Man, it is now pretty well demonstrated that they are aborigines and have inhabited the group from prehistoric times. Their nearest relatives, Wallace thinks, are the Samangs of the Malayan Peninsula and the Aetas of the Philippines. All of the tribes are of the same race, and there is no evidence of their ever having been crossed with other races. The inhabitants of Little Andaman may perhaps differ somewhat from their northern relatives,

but this difference may be attributed to their contact from time to time with their neighbors, the Nicobarese, from whom they doubtless learned to build houses.

The Andamanese can not well endure fasting or thirst. They appear to be very sensitive to cold as well as to the direct action of the sun's rays, from which they shield themselves with the greatest care, often using a palm-leaf screen (fig. 20, Pl. II) for this purpose, as well as covering their body with a coating of clay.

The voice of the men is described as being of medium loudness, growing deeper and fuller in tone with age. After having passed their prime, which is apparently about 35 years, it becomes rough, husky, and tuneless. The boys and women have clear, pleasant voices, but in singing, the voices of the women are of bad intonation. Falsetto singing is common in both sexes, though nasal intonation is not so marked as in many Oriental races. The prevailing male voice is barytone, the compass usually about an octave. All of the notes of the women are head tones.

#### FOOD.

Although the Andamanese do not practice agriculture nor rear animals, yet they do not lack a bountiful supply of food, which is yielded to them by the forest, the shore, and the sea. This they obtain with very little exertion, and, according to Mr. Man, their eagerness in the chase is induced almost as much by actual love of sport as by the necessity of obtaining food. Were this not the case they would hardly be found spending so much time in dancing and singing, in personal decoration, and in the preparation of their meals, while they reject with aversion anything that has become at all tainted. Further, it may be fairly estimated that one-third of the food daily consumed by them consists of edible roots, fruits, and honey. The remaining portion of the food is the flesh of one or more of the following, namely: Pig, paradoxurus, ignana, turtle, fish, and mollusks, with rare additions of pigeons and jungle fowl.

Their mode of eating meat is to cram a large piece into the mouth, and then to cut off whatever is in excess with a bamboo or cane (nowadays generally a steel) knife (Pl. II, figs. 6, 7, and 11). Water is their only beverage. If very thirsty while on a fishing expedition, and all the fresh water-supply is exhausted, the *Aryotoda* pour water over their heads or jump overboard, and even at times try to alleviate their sufferings by swallowing salt water.

The fruits of mangroves are eaten occasionally. They are first cooked as found, then peeled and soaked in water for a couple of days to remove the bitterness, after which they are either baked or boiled.

Some fruits are merely sucked for their flavor, others have fine wood ashes added to them, the alkali of which reduces their acidity, while a

few, like the mangrove, the seeds of the Leguminosæ creepers and of the jack fruit, and others resembling Cashew nuts, are cooked.

Their favorite fruits are those of *Mimusops indica*, the leaves of which are used by the women for aprons; *Baccaurea sapida*, of which the seed, as well as the fruit, are eaten, and the rotten logs used for fuel; *Gluta longipetiolata*, belonging to the *Anacardiaceæ*; *Cycas rumphii*, the seeds of which are eaten; several kinds of Diospyros, and the mangroves already referred to.

All animal food is thoroughly cooked. Brains and marrow, and the blood of turtles, which is boiled in the shell, are considered dainties. All animal food is preferred almost boiling hot. The natives frequently crack marrow bones with their teeth, which are usually sound and strong.

#### TATTOOING.

With the exception of tattooing and painting the body, no artificial deformity is met with. Mr. Man says that every woman is supposed to be proficient in shaving, tattooing, and scarifying. Those who have shown special skill in the art are the recognized practitioners. The operation is not accompanied by any ceremony. Very few children of either sex attain the age of eight years without having been partially tattooed. The final operation is usually performed about the sixteenth or eighteenth year.

#### BODY PAINTING.

Three kinds of pigment are used by the Andamanese for the adornment of their bodies: First, pale, olive-colored clay, called *ogda*; second, pure white clay, called *tala-ogda*; third, *koiobda*, or burnt yellow ocher. The first is mixed with water and smeared over the body, to denote mourning. After one has become heated by violent exercise, as in dancing or hunting, a thin coating of *ogda* is also applied to his body. The white clay is more highly prized than the olive-colored, on account of its great rarity. It is mixed with water and applied ornamentally, usually with the nail of the forefinger, in fine tattoo-like patterns, to the cheeks, body, and limbs. It is the duty of the women to adorn their relatives for festive occasions, and they vie with each other in the neatness and variety of their designs. The burnt ocher is mixed with melted fat, and occasionally with nut oil. It is used to anoint the bodies of both the living and the dead, but not upon a person in mourning. Unlike the designs made with white clay, those made with ocher paint are applied with the finger tips in rough zigzag stripes all over the body.

#### TRIBES.

The Andamanese are divided linguistically into at least nine tribes. In South and Little Andaman each tribe is divided into the coast

dwellers, or *Aryotoda*, and the jungle people, or *Erem-tagada*, who are allied in all respects except in their mode of life. It is impossible to determine the population, but Mr. Man estimates that the entire group contains about 4,000 souls.

#### CLOTHING AND ORNAMENTS.

No clothing is worn by either sex. Its place is taken in a measure by necklaces, circlets for the head, garters, bracelets, and belts. The materials used are screw-pine leaves, fringes of vegetable fiber, shells, orchid stems, fine netting, animal, and even human bones. Besides these, the skulls of the departed, their jaws, etc., usually painted red with white markings, and ornamented with shells, are worn suspended about the neck. Two skulls prepared in this way are shown on Pl. I, figs. 8 and 9 and Pl. V. Figs. 11 and 12 and Pl. VI show human jaws ornamented with shells; fig. 10, a necklace made of the vertebra of a half-grown child, also painted red and adorned with shell pendants; figs. 3, 5, 6, necklaces or head circlets of shells; fig. 13, a necklace of turtle bones; fig. 14, a head circlet of vegetable fiber; and fig. 21, the stems of an orchid.

The costume of a man consists of garters (figs. 19 and 20), bracelets (figs. 24 and 25), and wristlets (figs. 17 and 18) of pandanus leaves, often with the crumpled ends of the leaves forming a kind of tassel and sometimes ornamented with a fringe of shells (figs. 18, 19, 20); a folded pandanus leaf or circlet around the head, and a *bodda*, or belt (figs. 22 and 23) about the waist, from which two or four tufts of the pandanus leaves composing the belt hang down behind.

Women often wear four or five and even eight *bod-das*. In addition to the tufts of pandanus leaves, which hang down behind, they wear a diminutive apron of green leaves (fig. 16), which is kept in position by the lowest belt. Married women wear the *rugin-da* (fig. 15), which is a broad belt or hoop of pandanus leaves, ornamented on the outside by transverse or diagonal markings of red wax. Belts are sometimes made of simple strips of rattan (fig. 2). Slings are worn either by men or women (fig. 4) in the form of broad straps of bark, ornamented by red ocher and white clay, and are used for carrying babies.

The skulls of pigs (Pl. I, fig. 7) and fish (fig. 1) are often painted with red ocher and white clay, and kept as trophies.

#### HABITATIONS.

Three kinds of huts are erected by the Great Andaman tribes in their permanent and temporary encampments. The most durable of these consists of a roof of thatch made from the leaves of a species of *Calamus* neatly plaited and fastened together with cane, and laid in

rows on rafters supported on four posts, the two front posts varying in height from 6 to 9 feet and the two rear ones from 2 to 3 feet. Huts intended to last for a few months only are somewhat similar to the above, but smaller and covered with thatch of inferior quality. These huts are made by the men. They always sleep on a mat (Pl. II, fig. 19) or a bed of leaves spread under a shelter of one of the three classes above described.

The inhabitants of Little Andaman make beehive shaped huts with roofs coming close to the ground. They probably learned to construct these from their neighbors, the Nicobarese. In the houses skulls of pigs, turtles, and fishes, often ornamented with red paint, are found (Pl. I, figs. 1 and 7), and in the vicinity of encampments shell heaps invariably occur.

#### FIRE.

They preserve fire with great care, as they have not the art of producing it. In leaving an encampment with the intention of returning after a few days, besides taking with them one or more smoldering logs, they remove a large burning log or faggot to some sheltered spot, where it will smolder for a long time. In each inhabited hut is a fire, not only to keep the owner warm, but to drive away the insects, to cook food, and to smoke provisions. Fires are generally kindled by fanning the embers with a frond of the bird's-nest fern (*Asplenium nidus*). Torches (Pl. II, fig. 5) are made by the women by wrapping resin obtained from a species of *Stereulia* in the leaves of a lily (*Crinum lorifolium*). These are used when fishing or traveling, or when dancing at night. An inferior kind of torch (Pl. II, fig. 14) is made of rotten wood.

#### TOOLS AND UTENSILS.

Stones are used as anvils and hammers, clam shells (*Cyrena* sp.) in a variety of ways (Pl. II, fig. 12)—as knives for cutting palm leaves used in thatching, for making the ornamental incisions on bows, paddles, etc., for planing and smoothing bows and the wooden portions of arrows, for sharpening bamboo and cane knives and boar's tusks (Pl. II, fig. 13), for preparing fibers, and as spoons for eating. Area shells are employed for dressing the surface of pottery; pinna shells also as knives, as receptacles for white clay, and as plates for food; nautilus shells serve as drinking vessels.

The bamboo is made into water holders (Pl. II, fig. 18) and receptacles for cooked food when traveling; into shafts for turtle harpoons; knives (Pl. II, fig. 7), which are narrow pieces hardened over a fire and sharpened by means of a cyrena shell; netting needles; tongs (fig. 17), which consist of a strip of bamboo bent double and pointed at the ends; and *Bambusa nana* furnishes the shafts of the wooden and iron-pointed arrows.



The only thing resembling a musical instrument made by the Andamanese is a shield-like drum, upon which the performer keeps time by striking it with his foot.

From the drupe of a pandanus a paint brush is made by removing the pulp with a cyrena shell. This brush is used for painting the ornamental stripes on their baskets, baby slings, etc. Neither skins of animals nor thorns of trees or creepers are utilized by the Andamanese in their arts. Fly flaps are made by attaching vegetable fiber to a wooden handle (Pl. II, fig. 1).

#### IRONWORK.

Forging is unknown to the Andamanese. They obtain iron from wrecked ships, from old hoops, etc., and make knives (Pl. II, fig. 11), arrowheads, harpoon points, and adzes (Pl. II, fig. 4) of it, resting the piece of cold metal on a stone anvil, beating it with a hard, smooth stone to the required thinness, and shaping it by bending back the edge and beating it until broken off. The jagged edge is then ground down on a hone until the required shape is obtained.

#### POTTERY.

Clay suitable for making pottery is found only in a few places. This is cleaned of stones, mixed with water, and kneaded to the proper consistency. The base of the pot is made in the form of a cup. To this roll after roll of clay is added, and the sides built up, care being taken to insure uniformity and a proper thickness, and the inner and outer surfaces are smoothed off with an area shell, after which the vessel is ornamented with wavy, checkered, or striped designs by means of a pointed stick, when it is dried and baked by placing pieces of burning wood both inside and around the vessel.

#### BASKET WORK.

Baskets (Pl. II, figs. 22 and 23) are made of cane, called *pidgada*, which is cut into lengths of 3 or 4 feet, the skin split into strips. Baskets are much used by men, women, and children. Natives are seldom seen without them. Specimens were forwarded by Dr. Abbott both of wicker (fig. 23) and of wrapped (fig. 22) basket work.

#### WOODWORK.

In addition to the sounding-boards used for keeping time, the Andamanese make food trays (Pl. II, fig. 2) and buckets (fig. 21) for holding food.

## CORDAGE.

String is made for their harpoon lines, turtle nets and cables, hand-fishing nets, sleeping mats, bowstrings, arrow fastenings, reticules (Pl. II, fig. 16), and necklaces. The yellow skin of an orchid (*Dendrobium*) is often seen intertwined with the Anadendron string, and is used as an ornamentation in the lashings of spear heads (Pl. III, fig. 8), etc. Bowstrings are coated with wax.

## WEAPONS.

Bows and arrows are the principal weapons used by the Andamanese both in warfare and in hunting. Besides these, for spearing turtle and large fish a harpoon is used, and a peculiar fish spear consisting of a number of slender, pointed wooden rods arranged in a plane and diverging from the handle to the extremities. They are kept in place by small pieces of wood transversely lashed across them, as shown in fig. 13, Pl. III. Pig spears (fig. 8, Pl. 3) are of comparatively recent introduction.

## SIGMOID BOWS.

The S-shaped bows of the Great Andaman tribes are interesting from their resemblance to those used by the natives of New Ireland and of Mallicolo, one of the New Hebrides. As held in the hand, the upper part curves toward the marksman and the lower part away from him. Bows used by the tribes of South and Middle Andaman and in the archipelago are usually ornamented by longitudinal rows of X-shaped markings cut with a Cyrena shell, and are sometimes smeared with red ocher. The bowstring is made of the bark fiber of *Anodendron paniculatum*, which is usually coated with black beeswax. Those made by the North Andaman tribes (Pl. III, figs. 16 and 17) are of a neater and more elegant form. They have long attenuated extremities, are never ornamented by carving or painting, and are usually from 5 to 5½ feet long. In Middle and South Andaman the bows used in the interior for hunting are about 4 feet long. In the coast and in the open jungle, or when shooting fish, longer ones are used; and when made for presentation they are 6½ to 7 feet long, and are elaborately ornamented with lines of X-shaped incisions made with a Cyrena shell. On Pl. III, figs. 14 and 15, are types of the bows of South and Middle Andaman and of the archipelago, the latter being a bow of the usual size for hunting and the former, longer, broader, and more elaborately decorated (the markings on the flat surface can not be seen), for presentation. As shown in the figure the bow is inverted; the lower point is that which is held uppermost in firing. Figs. 16 and 17 are bows of the North Andamanese. As shown by fig. 16, the sigmoid curve is not so pronounced in this type as in that of their southern neighbors.

## SIMPLE BOWS.

The bows of the Jarawada tribes, inhabiting Little Andaman, Rutland Island, and a few other localities of the group, are simple in shape. Pl. III, fig. 1, shows a bow collected by Dr. Abbott at Bumila Creek, Little Andaman, and fig. 5 is a bow used by the Rutland Islanders. Sometimes bows are made for children of the wood of a mangrove (*Bruguiera gymnorhiza*).

## ARROWS.

The arrows of the Andamanese consist of a shaft of dwarf bamboo (*Bambusa nana*) and a foreshaft. The latter may be simply of the wood of a palm (*Areca* sp.) or mangrove, hardened by fire and left blunt for practicing at a mark or sharpened. Wooden-pointed arrows are used for shooting fish, and by the jungle tribes for other animals. They are made in great numbers by these people and taken by them to the coast and bartered for iron-pointed arrows, turtle oil, etc.

Sometimes fish arrows are provided with two or more long, slender, sharp wooden points. Pl. III, fig. 2, shows a three-pointed fish arrow collected by Dr. Abbott at Bumila Creek, Little Andaman; fig. 4 is a two-pointed arrow picked up by him on North Cinque, an islet on the southwest coast of Rutland Island; fig. 3 is the simple wooden-pointed arrow. The foreshafts of fish arrows are frequently iron-pointed. The point may consist of a piece of stout iron wire or a nail sharpened at each end, the proximal end extending obliquely backward to form a barb, "boat-hook fashion," as seen in figs. 6 and 7, Pl. III, or it may be provided with a flattened iron head and barbs, as in fig. 12. The string seizings attaching the head and barbs to the foreshaft are protected by a coating of red wax. In former times fish arrows were often pointed with bone; the serrated bone from the tail of a sting-ray, of such general use in Polynesia, was often used for this purpose.

## HARPOON ARROWS.

These are arrows of which the foreshaft is detachable and is connected with the shaft near the end of the latter by a stout, flat lanyard about 5 inches long, made of the fiber of *Anodendron paniculatum*. The foreshaft is provided with an iron head and one, two, or three barbs (see Pl. III, figs. 9, 10, and 11; also Pl. IV). The seizings attaching the head and the lanyard to the foreshaft are protected by a smooth, solid coating of red wax. These harpoon arrows, called *da-da*, are used for shooting pigs. The foreshaft is thrust into a socket at the end of the shaft and twisted until the lanyard forms a tight coil about the upper part of the shaft. When an animal is struck the barbs of the arrow hold the head with the foreshaft attached firmly in the flesh, the shaft is knocked loose as the animal rushes through the

jungle, dragging the shaft behind it; and as the latter is made fast to the lanyard at some distance from the end, it trails at an angle and is soon caught in the bushes, holding the wounded animal until the hunter comes to dispatch it.

#### TURTLE HARPOONS.

A turtle harpoon line made of the bark fiber of *Melochia arborea*, with the barbed iron point attached, is shown on Pl. III, fig. 18. The point is set in a sort of conical plug, which fits tightly into a socket at the end of a bamboo shaft, often 18 feet or more in length. When a turtle or large fish is struck the shaft becomes detached, and is picked up after the animal has been captured.

#### CANOES.

Both outrigger canoes and simple dugouts are used by the Andamanese. They are propelled by paddles, or, in shallow water, by poles or the shaft of a turtle harpoon. A narrow projecting bow is considered by them to be a great advantage for throwing the harpoon in turtle fishing. The anchor is merely a large stone or lump of corral, the cable a rope of the same fiber as the harpoon line.

For the social life of the Andamanese, their marriage customs, ceremonies, etc., the reader is referred to the work of Mr. E. H. Man, from which much of the foregoing information has been obtained.



## EXPLANATION OF PLATE I.

1. Fish skull, painted with red ocher, kept as a trophy.
2. Belt, or waist circlet, of rattan.
3. Circlet of spiral shells on network, worn on the head or neck.
4. Band of bark, worn over the shoulder, for carrying child.
5. Necklace of shells (*Hemicardium unedo*).
6. Necklace of calyces of mangrove.
7. Pig's skull, painted with red ocher and white clay, kept as a trophy.
8. Human skull, painted with red ocher and white clay, and ornamented with Dentalium shells, and with Hemicardium and Solarium shells attached to the temporal arches; worn *in memoriam* by a relative of the deceased.
9. Human skull, suspended by cord of bark fiber.
10. Circlet made of vertebrae of a half-grown child; worn on the head or about the neck *in memoriam* by a relative of the deceased.
11. Human jawbone, worn like the preceding, ornamented by strings of *Dentalium octogonum*.
12. Human jawbone, painted, with red ocher, and ornamented with Hemicardium shells; suspended by network of bark fiber.
13. Circlet of turtle bones, worn about the head or neck.
14. Circlet of vegetable fiber, worn on the head.
15. Woman's belt, made of *Pandanus andamanensisum*, the ends of the leaves forming four tufts, which are worn behind, the outside of the hoop ornamented with transverse markings of red wax paint. Several belts are worn by each woman.
16. Tuft of leaves of *Minusops indica*; worn by the women as an apron, held in place by the lowest belt.
17. Wristlet made of leaves of *Pandanus andamanensisum*.
18. Wristlet, or bracelet, similar to the preceding, but ornamented with strings of Dentalium shells.
19. Garter of Pandanus leaves, ornamented with Dentalium shells.
20. Circlet, similar to the preceding.
21. Stems of an orchid (*Dendrobium* sp.), the yellow skin of which is used to ornament cords, and the seizings of pig-spear heads.
22. Man's belt of Pandanus leaves, with two tufts, intended to hang down behind.
23. Belt similar to the preceding, but having four tufts of Pandanus leaves.
24. Man's garters of Pandanus leaves, made like the preceding.
25. Garter in the form of a flat hoop of Pandanus leaves, made like fig. 15, and ornamented in the same way.
26. Man's belt, consisting of a fringe of Dentalium shells, coated with red ocher.

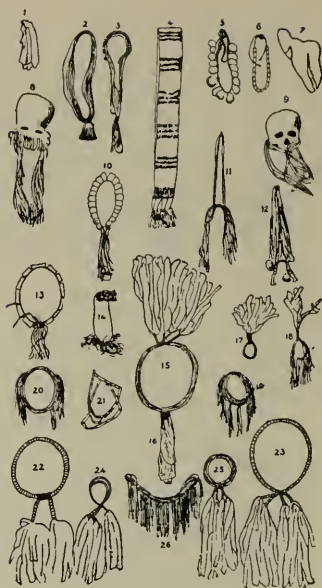



NATIVE ORNAMENTS FROM ANDAMAN ISLANDS.







## EXPLANATION OF PLATE II.

1. Fly brush consisting of strips of *Pandanus* leaves secured to a wooden handle by a lashing of rattan.
2. Food tray of wood.
3. Fiber of *Gnetum edule*, from which the pulp has been removed by scraping the bark with a *Cyrena* shell.
4. Adz (modern) made of iron obtained from the keel plate of a vessel. Shells were formerly used, but stones were never used by the Andamanese for celts.
5. Torch, made by women, of resin wrapped in an *Amaryllis* leaf (*Crinum lorifolium*).
- 6, 7. Bamboo knives made by hardening the strips with fire and sharpening the edges with a *Cyrena* shell.
8. Bamboo skewer with shells attached.
9. Red wax, made by men, of red oxide of iron, resin obtained from a tree (*Celtis*?), and white beeswax; used to form a protective coating over seizings of arrowheads, harpoons, etc.; for ornamenting food trays, buckets, and belts, and sometimes for closing the seams of canoes and cracks in wooden buckets.
10. Pinna shell knives, now seldom used, their place having been taken by iron obtained from hoops, plates from vessels, etc.
11. Skewer attached to iron knife.
12. *Cyrena* shells, the edge sharpened, and used for cutting, carving, and for smoothing bows and arrows.
13. Boar's tusk, the inner edge of which has been sharpened with a *Cyrena* shell. Used for planing bows, arrows, and paddles.
14. Torch of resinous wood, from decayed logs of *Dipterocarpus lavis*. They do not burn so readily as the torch of resin (fig. 5) and are seldom used outside of the huts.
15. Fiber of *Anodendron paniculatum*, of which bowstrings, arrow fastenings, and nettings are made.
16. Woman's reticule, netted from fine string made of the fiber of *Anodendron paniculatum*.
17. Bamboo tongs.
18. Bamboo water vessel.
19. Sleeping mat, made of *Calamus* strips twined together with string twisted from the fiber of *Gnetum edule*, and decorated with lines of red ochre and white clay.
20. Palm-leaf screen (*Licuala peltata*?).
21. Bucket made of the wood of *Sterculia villosa*, with a loop of cane to form the handle, made by means of an adz blade attached to a handle in the form of a chisel; ornamented with longitudinal markings of red and white.
22. Wrapped basket with conical bottom.
23. Wicker basket with reentrant bottom.

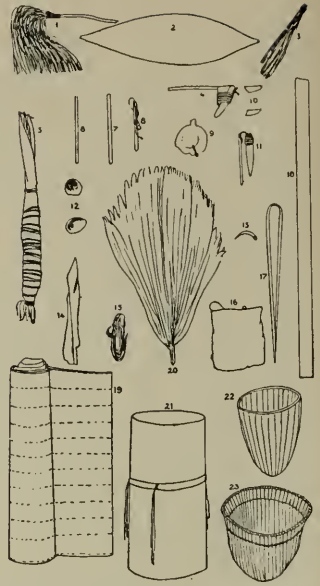



NATIVE IMPLEMENTS FROM ANDAMAN ISLANDS.





## EXPLANATION OF PLATE III.

1. Simple bow from Little Andaman Island.
2. Three-pointed wooden fish arrow, from Bumila Creek, Little Andaman.
3. Fish arrow, foreshaft of wood hardened by fire and pointed, shaft of *Bambusa nana*.
4. Two-pointed wooden fish arrow, North Cinque Island.
5. Simple bow from Rutland Island.
- 6, 7. Fish arrows, foreshafts pointed with wire sharpened at each end, extending obliquely backward to form a barb, the seizings protected by coating of red wax.
8. Three pig spears; iron heads secured by seizings of *Anadendron paniculatum* fiber, and ornamented with strips of yellow *Dendrobium* bark.
- 9, 10, 11. Harpoon arrows for killing pigs (see Pl. IV).
12. Fish arrow with barbed iron head.
13. Many pointed fish spear of wood.
- 14 and 15. Sigmoid bows used by the natives of South and Middle Andaman and the "Archipelago," ornamented with lines of X-shaped incisions made with a Cyrena shell.
- 16, 17. Sigmoid bows used by natives of North Andaman.



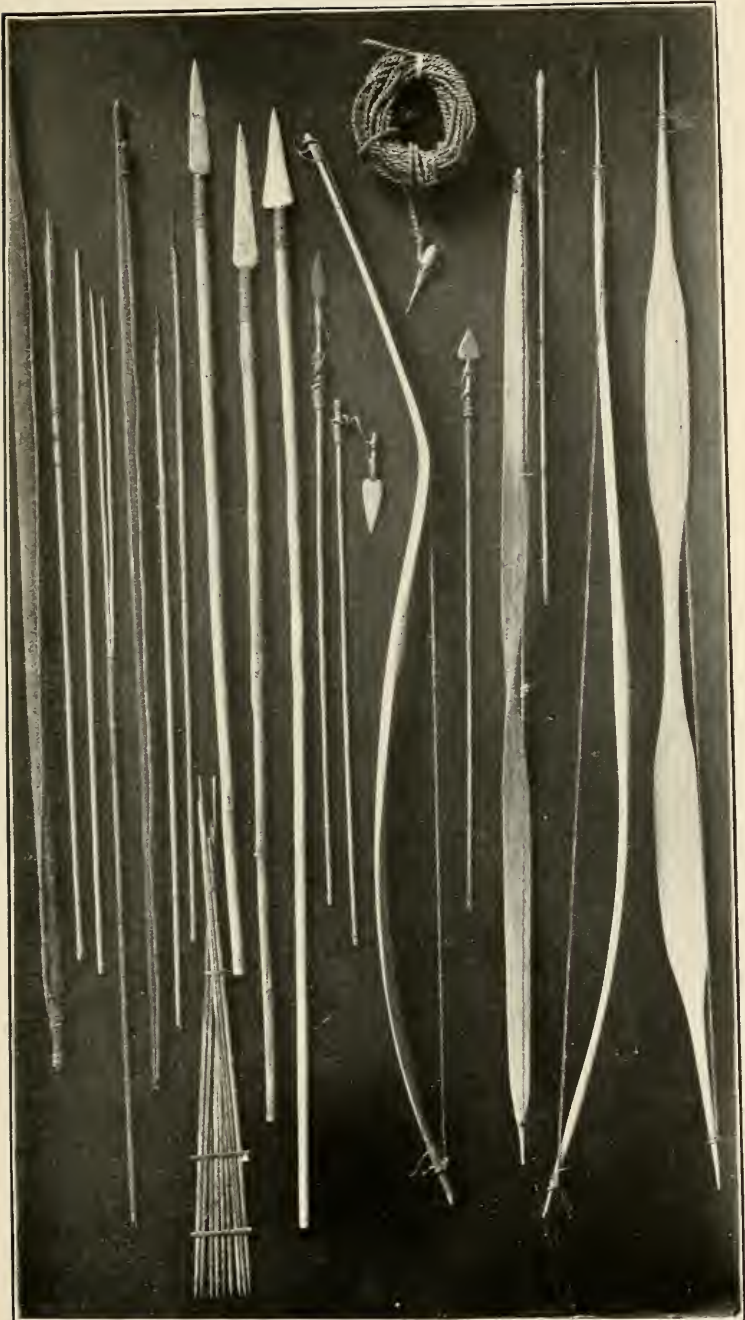

BOWS AND ARROWS FROM ANDAMAN ISLANDS.





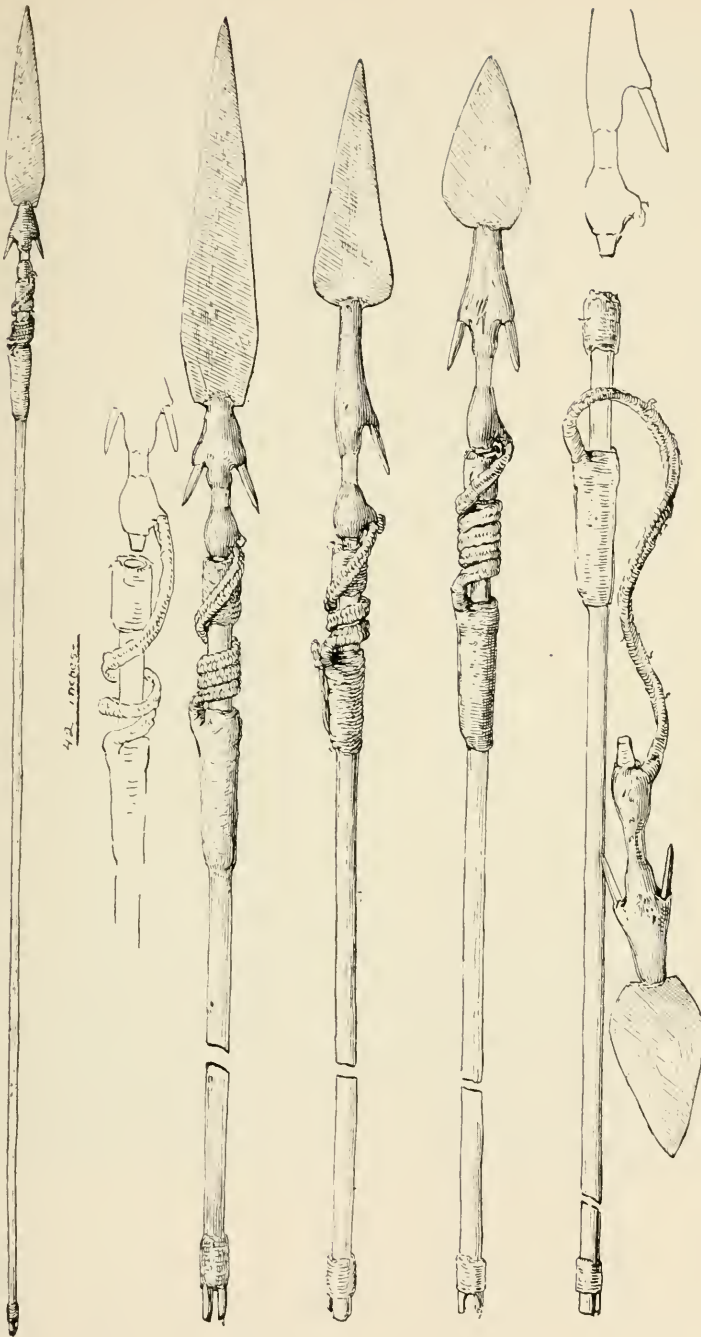

HARPOON ARROWS FOR KILLING PIGS.



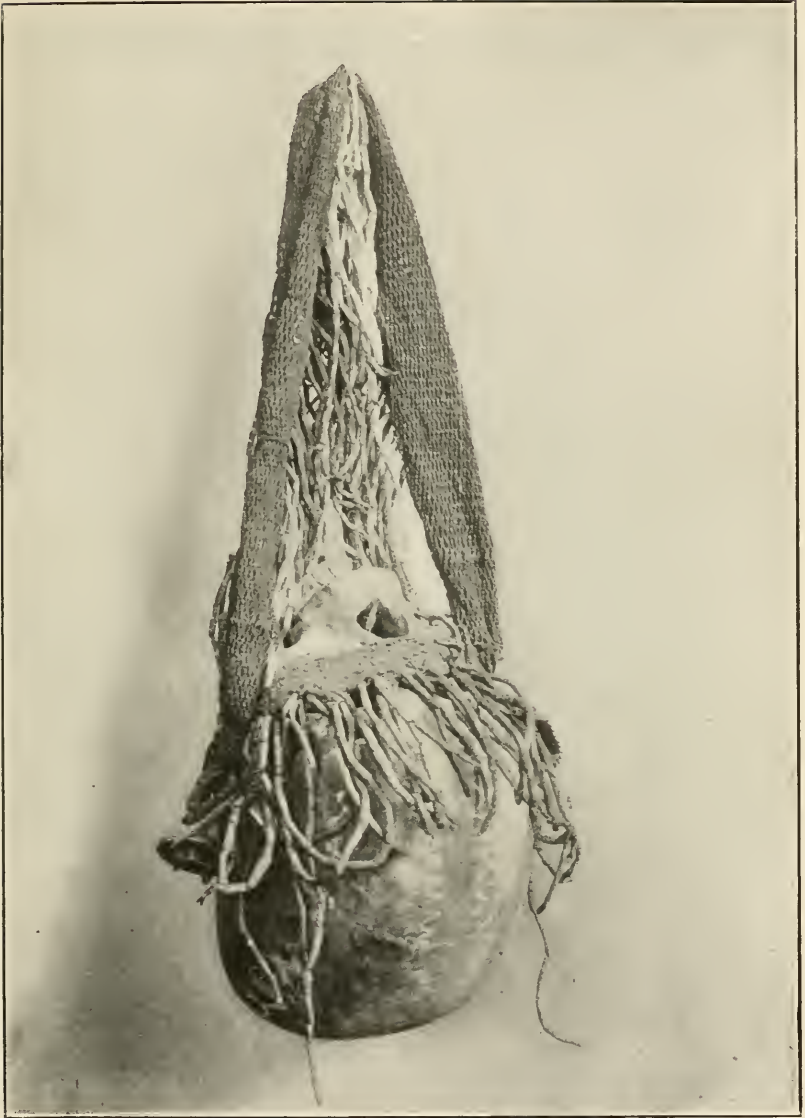

SKULL OF DECEASED RELATIVE, WORN AS A NECKLACE.



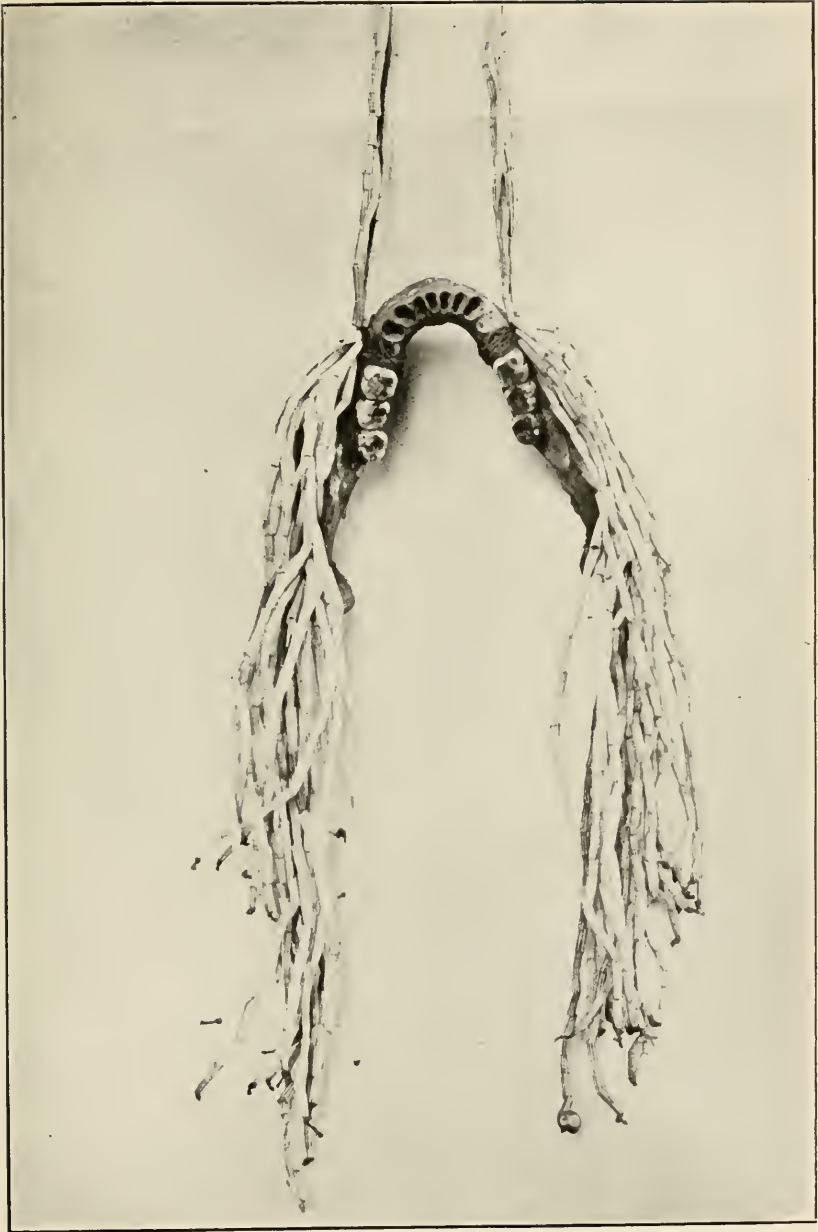

BEAD-ORNAMENTED HUMAN JAWBONE, WORN AS A NECKLACE.



## THE DEVELOPMENT OF ILLUMINATION.<sup>a</sup>

By WALTER HOUGH.

Before the period of artificial illumination there were many manifestations of light in nature coming to the aid of the denizens of the earth during the hours of darkness. Of these were the so-called luciform appearances, including the aurora borealis and australis, which enliven the long nights at the polar zones; the magellan clouds of the Southern Hemisphere; the zodiacal light, whose cause was long a subject of speculation, and the diffused light of the milky way, known to the Chinese as the "river of the sky."

The light from the stars and planets is not inconsiderable. Under the clear night sky of the Arizona deserts the atmosphere seems charged with star mist; eminences miles away may be outlined, the dial of a watch may be read, and a trail followed with little difficulty. These are the conditions under which night journeys are made to avoid the burning sun. The planet Venus, at inferior conjunction especially, sheds light sufficient for the traveler over open country.

There are at times nights of remarkable luminescence. Clouds become phosphorescent, and often under certain states of electric stress, during high winds, glimmer with a faint light not amounting to a discharge of the electric fluid. Frequently successive flashes of "heat lightning" aid the traveler in finding his way. It is possible, also, that the soil over certain regions may become phosphorescent under the light of the sun and retain the property during the night, as certain gems are phosphorescent after being submitted to sunlight. Snow has this property. Gaseous emanations of a phosphorescent character are occasionally abundant enough to produce temporary illumination.

Next to the sun in value to man as a light producer is the moon. Though intermittent in the power and duration of its light, the moon has proven a valuable auxiliary on the night side of man's life, and its period has given a measurement of aggregates of time.

In torrid climates, and at hot seasons of the year, work is often

<sup>a</sup> Read at the Congrès International d'Anthropologie et d'Archéologie Préhistoriques, XII session, Paris, August, 1900. (Reprinted from the American Anthropologist (N. S.), Vol. III, April-June, 1901.)

carried on by moonlight in order to escape the heat of the day. While moonlight is 450,000 times less bright than daylight, under certain favorable conditions the light seems intense and ample for many purposes.

The well-known phosphorescence of lichens has been found to give considerable light during warm, moist nights in the summer. Certain flowers are phosphorescent, or emit flashes of light, as the tuberose and moonflower. In the vegetable world there are numerous sources of light whose faintness causes them to escape ordinary observation. As an aid to man, however, the light from the vegetable kingdom is far less useful than that yielded by the animal kingdom.

When the animal kingdom is reached, numerous examples of light phenomena connected with vital processes are found. The familiar firefly of northern latitudes frequently renders summer nights luminous, while the tropical noctilucideæ yield an actual and valuable illumination which has been utilized as light in several interesting ways by the inhabitants of regions in which the insects are found.

The distinguished traveler Kaempfer described the fireflies of Siam as "settling upon the trees like a fiery cloud," and in Brazil Gardner compares them in brilliancy with "stars that have fallen from the firmament and are floating about without a resting place." Kidder says: "In the mountains of Tijuca I have read the finest print of Harper's Magazine by the light of one of these natural lamps placed under a common glass tumbler, and with distinctness I could tell the hour of the night and discern the very small figures which marked the seconds of a little Swiss watch. The Indians formerly used them instead of flambeaux in their hunting and fishing excursions, and when traveling in the night they are accustomed to fasten them to their feet and hands. And they are used by señoritas for adorning their tresses. Prescott narrates the terror they inspired in the Spaniards in 1520. 'The air was filled with "cocuyos," a species of large beetle which emits an intense phosphoric light from its body strong enough to enable one to read by it. These wandering fires seen in the darkness of the night were converted by the besieged into an army of matchlocks,' so says Bernal Diaz."<sup>a</sup>

The bearing of the light of the firefly on the light of the future is very important, and the investigations carried on at the Smithsonian Institution a few years ago may introduce a new epoch in illumination. A brief account in the Philadelphia American states that "some interesting experiments upon the nature and origin of the light emitted by the firefly have lately been made by Prof. S. P. Langley. From the spectroscope he finds the light to be of exceedingly narrow range of refrangibility. The heat given out is scarcely appreciable, being less than one-half of 1 per cent of that produced by an equal amount of

<sup>a</sup> Kidder and Fletcher, Brazil and the Brazilians, Phila., 1857, p. 293.



light from a candle or other common illuminant. That the light is a chemical product would seem to be established by the fact that it decreases by products which check combustion (e. g., nitrogen) and increases by products which aid combustion (oxygen), and that the product of the process is apparently carbon dioxide. The subject of the origin of 'phosphorescent' light is one that may develop very interesting features, for, as graphically stated by Prof. Oliver J. Lodge, if the secret of the firefly were known, a boy turning a crank might be able to furnish the energy necessary to light an entire electric circuit. From this standpoint Professor Lodge regards as enormous the waste of energy in the machinery of electric-light making now in use."

Most of the 150 species of animals which are light-producing inhabit the sea, where their light is of small importance to man. The wonderful phosphorescence of the tropical seas, which has drawn forth many descriptions of its beauty, is caused by the collective lights of myriads of infusorie on the surface of the water.

The day opens up a vast field of activities requiring light for their prosecution. Solar light is normal for the carrying on of these activities, and the night is normal for rest and recuperative processes. The important phenomena of the day are sunrise and sunset; and the day's labor regulates itself to twilight, morning and evening hours, and the hours of broad day divided by the meridian of the sun. Sunrise is attended with certain phenomena, which observant people have noticed.

The Hopi tribe of Arizona, for instance, employ the following terms for sunrise: Sunrise, *talaraiya*; place of sunrise, *tawa yam tyaki*; faintest dawn, *kûyañiptü*; first light, *talti*; light of sunrise, *taláwe*; yellow light of sunrise, *sikyañüptü*; before emergence of sun, *tawa küyira*, "sun appears;" sunup, *tawa yama*.<sup>a</sup> Few tribes indeed have not been impressed with dawn and sunset, and few in the oblique latitudes have failed to mark the seasonal progress of the sun along the horizon.

There is a wide difference in the amount of sunlight enjoyed by the dwellers on the earth's surface, depending on the height and configuration of the land, its absorptive and reflective qualities, the presence of forests and vegetation, the amount of moisture and dust in the air, cloud formation, and other elements which suggest themselves to the reader, producing local and periodical variation. To these must be added the seasons and the position in latitude determining the length of the day and the duration of twilight.

The superabundance of sunlight has brought about many devices for warding off and tempering the rays and ameliorating their heat. For protecting his eyes from the excessive light man has devised eye-shades, hats, and parasols; and for shade and protection from the heat,

<sup>a</sup> Authority of Dr. J. Walter Fewkes.

shelters of brush, skin, or cloth. In some environments the chief function of the house seems to be for shelter against a burning sun, and this points out a probable origin of the house in tropical countries.

Nowhere is this regulation of daylight more thoroughly carried out than in our modern houses of the temperate regions, whose development has been along the praiseworthy lines of more light and air. What the ancients directly accomplished by small light openings requires now hangings, lace curtains, inside shutters, blinds, perhaps sash curtains, outside shutters, and an awning. These may further be reinforced by shade trees. With all these adjuncts one might be led to believe that the dim light of the early houses is still preferred by the moderns.

As a corollary of protection from the sun follows the observation that tribes living in the shade become lighter in color than their fellows living in the open country. It is also true that there is a characteristic facial modification, such as wrinkling and contorting about the eyes produced in those who are exposed to the glaring light of the deserts or the sea.

Without doubt man is a diurnal animal; his eyes have not the condensing power of those of the *Felidae* and other nocturnal beasts. The man apes are also day animals, and those tribes of mankind retaining a degree of primitiveness regulate their rest to the setting and rising of the sun.

With the use of fire begins the history of artificial illumination. The nocturnal light of nature became then of little moment in comparison with fire lights and the burning brand in the hand of man; the conquest of light over darkness was signaled, and the night side of man's life and his progress toward culture became a theme of surpassing interest.

There perhaps can not be a satisfactory reconstruction of the period before the knowledge of fire, and the difficulty persists in the subsequent stages of the acquisition and use of fire, and the generation of fire at will—stages grasped by the philosophic mind of Paul Broca.

One fact stands out clearly—that man unacquainted with fire is unknown. With the light of the camp fire comes the torch, and from this starting point, by the help of observations on less civilized peoples, it may be possible to reconstruct the history of artificial illumination and to check it in some degree by the aid of archæology.

The following table, briefly epitomizing the development of the candle, is presented as the result of extended research in this direction:

#### DEVELOPMENT OF THE CANDLE.

##### *Protoillumination in line of torch:*

Fireflies used as torches. Fat bodies of birds and fish burned for light.

Prototorch (adventitious and temporary):

1. Firebrand, branches, resinous wood, bark, leaves, etc.

Torch (for customary use):

2. Slivers or other elements tied together in a bundle.
3. Roll of resin wrapped in leaves.

Proto-candle:

4. Rope soaked in resin.
5. Fiber soaked in fat or wax.
6. Rush soaked in grease.
7. Stick or splint with grease for lighting.

Candle:

8. Mass of fat formed upon a stick around which is wound a wick of fiber.
9. Candles of wax or fat.
10. Dipped candles.
11. Molded candles; improved and art candles of twentieth century.

While the line of development has proceeded from the rude torch to the candle, the steps marked in the series are suggestive, embracing devices used by different peoples and at divers times. There is not space here to present the results of investigations among different peoples and in special areas. It will be seen that the purpose for which light is to be used, the place in which it is to be used, the period, and the resources of the environment, are among the modifying influences on materials and apparatus. Hence the complete steps of the development may not be exemplified in a given area, though a number of superposed phases of light utilization may exist side by side. It is true, also, that the growing need for light has brought a closer association of the means of illumination with the life of man. The smoking torch, for example, is utilized for open-air illumination, while the candle enters the house and companionship of the family.

Following the torch in the line of development comes the lamp, which separated from the stem of the torch at a period when oils and fat came to be used. This may have occurred (1) as a concomitant of migration or after the domestication of animals whose fat was available; (2) at the time of the discovery of mineral oil, (3) or of the utilization of vegetal oils, such as that of the olive and the cocoanut.

The lamp appears to have arisen at a period after migrations into the temperate zones had brought man into new conditions. The principal of these was the longer night, and joined to this was the settlement in comparatively permanent habitations. In this view the fire stick and torch were the essential accompaniments of early migration and without doubt determined the spread of man over the earth's surface.

Since the torch, from its perishable character, is rarely found on ancient sites, there is little to be said as to its archaeology. The lamp, on the contrary, being a higher idea, involves work in stone, pottery, bronze, or iron, producing objects which survive burial in the soil.

Discoveries by French archaeologists have shown that the lamp was in use at the close of the lacustrian bronze age, and up to the present time these are the most ancient objects which have been found that are unmistakably lamps.

It would seem that the lamp with a wick had its origin at a culture plane represented by that of the bronze age, though such employment of fire might have been prefigured by usages in the age of polished stone. Again, the latitude and consequent difference in temperature of stations have exerted controlling influence on the character of the early lamps which it might be possible to employ. Thus climatic conditions render the fuel supply of the lamp solid or fluid and broadly determine the form of the reservoir.

It is almost safe to say that the higher types of illuminating apparatus would not have developed except in the temperate zone or the region of long nights. The tallow candle is a device of cold regions; the same may be affirmed of the open fat lamp. The form of the latter seems to depend upon the character of its fuel supply, and this cause no doubt constantly gives rise to forms of extreme primitiveness in the midst of a high civilization, aside from those descending from the primitive type and retained in use through the working of the large body of survivals of custom in every society.

#### DEVELOPMENT OF THE LAMP.

The series might have grouped at the beginning devices for producing a temporary light and those undifferentiated lamps of skulls and bones. The bodies of birds and fish burned by means of a wick also may be classed with the lamps.

#### TEMPORARY LIGHT.

1. Oil bag from which oil is thrown on a fire to produce a temporary light. Kwakiutl Indians, British Columbia. Lighting apparatus of skulls or bones suggestive of primitive lamps.

2. Lamp. Unworked beach stone with a concavity, supplied with oil and having the wick laid along one edge. Aleut shell heaps.

3. Lamp. Hollowed beach stone with moss wick arranged along one edge. Worked stone lamps. Eskimo.

4. Lamp of pecten shell with oil and wick of rush pith. Ainos, Japan. Fusus shell hanging lamp. Orkney islands.

5. Lamp. Terracotta saucer, China. India, etc.

6. Terracotta saucer with edge pinched up into gutter or gutters for wick. Syria and India.

7. Lamp. Terracotta. Reservoir almost closed over; spout for wick. Lamps of pottery with reservoir closed over. Lamps of bronze with one or more wick spouts. Roman.

8. Lamps of iron of simple shape with plain open or closed reservoir and with spout, and often having dip catchers and a device for tipping to allow the oil to reach the wick. There is considerable variety of such lamps, which were used in Europe before the epoch-making invention of Argand. Being products of the blacksmith's hammer, they present a certain crudity, as of antiquity. However, there is no reason to doubt that they are the survivals of the forms of the iron age.

It may be interesting to briefly pursue the line of the lamp into the inventive age.

## LAMPS OF THE INVENTIVE ERA.

9. Lamp of brass with reservoir mounted on rod and stand; several curving spouts. Italian. Development from the Roman lamp.

10. Lamp of brass designed to furnish heavy oil to the wick under hydrostatic pressure. Flemish.

11. Lamp with chimney; draft to flame and heavy oil under gravity pressure. Argand's invention and French inventors.

12. Lamp with chimney and Argand burner; heavy oil under forced pressure of a spring. Devices for heating heavy oil. France.

13. Lamp of glass having one or two tubes; for burning whale oil.

14. Lamp burning "camphene" by means of wick and tubes and without chimney. United States.

15. Lamp with chimney; ventilated burner; woven wick raising refined petroleum by capillarity. United States, 1870. Developed burner to end of century.

At present the destiny of illumination is in the hands of the investigator and inventor. Who knows to what heights their efforts will lead? But before the inventive era, before Argand, if you please, the world satisfied its needs for light with the immemorial simple lamp and smoky torch, increasing the illumination at times by multiplying the number of lights, and casting over scenes of splendor the flare of torches little removed in simplicity from those of prehistoric man.

It may be a wholesome correction of our pride in the advance of a century to reflect that most of the human race is still in the uninventive period, depending for light on torches and simple saucer lamps.

The epoch-making invention of the chimney and the discovery of boundless hydrocarbons in the earth have not yet reached the majority of mankind, while the electric light casts its bright rays in a very small area of immense obscurity. Still there is progress, and gradually tribes from their beginnings unacquainted with more than the most simple illuminating methods are seeking more light.

It is interesting to note in this connection the education of the Hopi Indians of Arizona in the use of artificial illumination. The environment of these Indians is semiarid, and there is such scarcity of fuel in their isolated country that it must be used sparingly for cooking and

only as a luxury for illumination. Hence, up to a few years ago, all avocations ceased at dark. Four years ago the writer, while encamping at Walpi, noticed only a solitary light at night in the pueblo. There was at that time a demand for candles. Two years later a number of lights shone from the windows of the village. Lately coal oil has become known; a great many families possess the luxury of a coal-oil lamp, and this has worked a great change in the habits of the people. This seems in epitome the history of illumination.



TORCHES AND CANDLES.





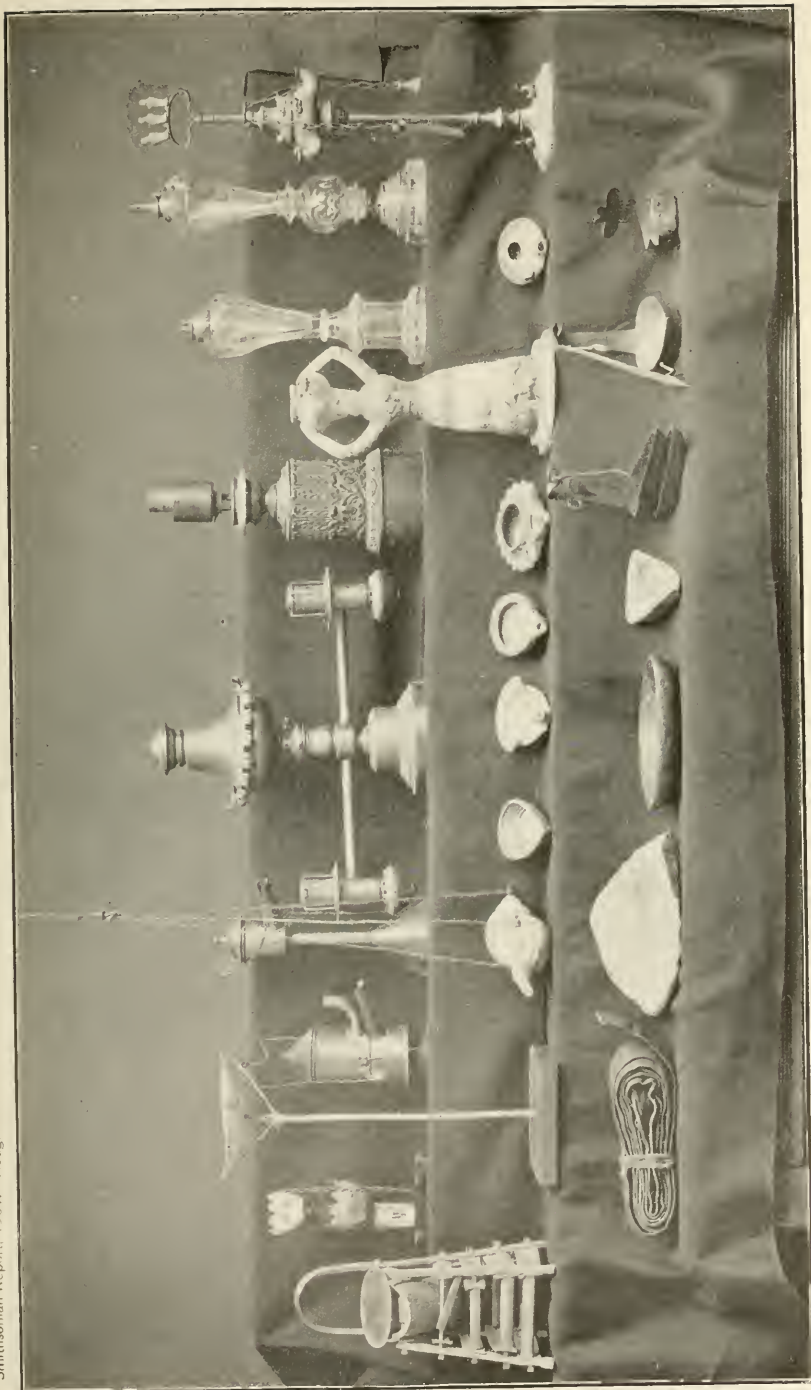



## ORDER OF DEVELOPMENT OF THE PRIMAL SHAPING ARTS.<sup>a</sup>

BY W. H. HOLMES.

Modern science has gone far toward establishing the proposition that the human race, like the various other groups of sentient beings, is the product of evolutionary processes, and the student of history has added the corollary that human culture has likewise developed through a long series of progressive stages from infinitesimal germs up to the present complex and wonderful conditions. The history of culture can not, therefore, be complete until the course of its development has been traced back to the remotest beginnings. The phenomena of art are the tangible representatives of human progress and achievement, and upon these we are almost wholly dependent for an insight into the initial stages of history. Furthermore, there is a shadowy interval at the very beginning of culture history unrepresented by art remains. Into this space we seek to extend our vision by the aid of rays borrowed from other branches of science.

Assuming the general uniformity of nature's genetic processes, we conclude that in the beginning there was a period of rudimentary or instinctive use of materials during which our race carried on its activities much as the bird builds her nest of sticks and grass and the badger burrows a home in the ground. But the time must have come when the hand of this creature, man, was so developed and his brain so matured that articles supplied by nature, such as sticks and stones, were held in the hand for throwing, striking, and rubbing. These things became implements, multiplying the powers of the hand and finally giving man dominion over nature.

The first stage of implement using would consist in the employment of articles furnished by nature. The second stage would be entered upon when the things used began to be modified in shape designedly to increase their efficiency. The passage from the first to the second stage would be made possible by unintentional alterations of the primal utensils brought about through use, and the observation of the processes of modification by creatures able to profit by these observations. This stage would witness the beginning of those manual operations to which we give the name "the shaping arts." It is these first necessary steps in art, weak and hesitating and almost infinitely slow as they must have been, that more than any others demand the attention of the student of history.

<sup>a</sup> From the Proceedings of the American Association for the Advancement of Science, Vol. XLII, 1894.

There is little prospect of securing examples of the earliest products of men's hands, as they were probably executed in destructible materials and have long since disappeared. As soon, however, as the shaping operations extended to stone, permanent records were made and many artifacts, representing all stages and periods, are still extant, forming the only actual evidence of the early struggles and achievements of the race. Archaeologists are engaged in collecting these remains and arranging them according to the plan suggested by the general scheme of evolution, applying the result to the elucidation of human history.

Consideration of the entire body of phenomena of art in stone is not possible in the present study, and I shall confine myself to a small portion of the field—to the initial stages.

A glance at the accompanying synopsis will convey a definite notion of the relation of the group of phenomena here to be considered to the whole field of the shaping arts. These arts may be divided primarily into manual and physical groups. The first includes all those things shaped directly by the human hand, aided by mechanical appliances; the second includes those in which the manual operations are assisted by physical processes or agents, such as heat, acids, and electricity.

The manual arts employ mainly six groups of processes, to which I have given the names fracturing, bruising, abrading, incising, modeling, and constructing. Four of these groups—the four placed first in the synopsis—are concerned in our studies of the earliest culture, and pertain to the shaping of stone in its elementary utilization.

#### SYNOPSIS OF THE SHAPING ARTS.

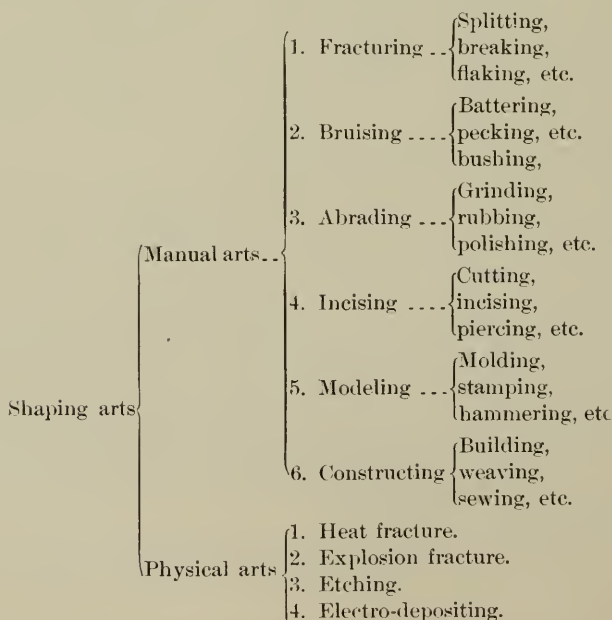

## ORIGIN OF MANUAL PROCESSES.

Taking the evolutionary view of the development of man and his arts, we must first turn our attention toward the probable activities of the creature man as he issued from the prehuman stage and began slowly to make use of the objects with which he was surrounded for implements and utensils. By the utilization of stone in the form of fragments, nodules, and boulders, the properties of that material would be gradually revealed to him, and in time four processes of modifying its shapes would inevitably be suggested and utilized. These are fracturing, bruising, abrading, and incising.

## FRACTURING PROCESSES.

The fracturing processes are placed first for reasons that will appear in the sequel. As known to us, they employ two groups of acts, percussion, and pressure. The first of these implies the use of a hard and heavy implement with which the stone to be shaped is struck, producing fracture; the second implies an implement of at least moderate hardness, which is pressed against the brittle stone, producing fracture. These necessary acts—the simple manual operations—are so elemental as to be within the reach of man in a very low stage of mental and physical development. The first—percussion—probably the only act employed in the auroral days, demands nothing more in the way of skill than that required in the casting or striking of one stone against another, or that required in the cracking of a skull or a nut. In the operation of this process a hard, compact hammer of stone or other suitable material having a convex striking surface is essential. The second process—pressure—is less primal, requiring, before it can be operated with success, a specially prepared tool of hard wood, bone, or other compact substance. The several varieties of acts employed in fracturing are named, according to the nature of the particular results produced, “breaking,” “splitting,” “flaking,” and “chipping.” The term “flaking” is in common use to represent the form-elaborating operations of the group. The material shaped must be measurably compact, homogeneous, and brittle. Such stone is widely distributed over the habitable world.

## BRUISING OR BATTERING PROCESSES.

The acts employed in this class of operations are wholly or in the main percussive, the impact resulting in a bruising and crumbling of minute portions of the surface of the stone. The hammer employed must be hard and tough, and the stone shaped must be sufficiently tough to practically preclude fracture by the ordinary blow. The simple act, like that required for fracture, is quite elemental and within the reach of a creature of low organization. No specialized

tool is necessary, the result being reached by striking one stone against another of proper relative durability. The several acts are known as "battering," "bruising," and "pecking," the last term being in common use for the act by which shaping is mostly accomplished by primitive peoples. Materials suitable for shaping by this process are plentiful and very generally distributed.

#### ABRADING PROCESSES.

Shaping by abrasion in its most elemental form results from the rubbing of one object against another with such force as to remove minute particles from one or both. The operations are generally expressed by such terms as "grinding," "rubbing," and "polishing." All stones are abradable, and most stones can be made to serve in the active operations of abrading. The act is so simple that it may be performed by any creature having power to grasp the rubbing stone. Its employment in the shaping arts was undoubtedly primal, although it may be hard to secure tangible evidence on this point.

#### INCISING PROCESSES.

The incising acts are also simple in their nature. In their most elementary form they are practiced by all creatures having teeth and nails. In art they include the shaping of materials by cutting, piercing, picking, scraping, etc. They imply the use of a hard edged or pointed tool and a substance to be shaped somewhat less hard. Though a primal art, it is doubtful whether incising was applied to the shaping of stone in the earliest times. This appears from the permissible assumption that stone soft enough to be cut and scraped would not be required in the simple acts of food-getting and defense, and the making of vessels, pipes, ornaments, and ceremonial objects did not form a part of the accomplishments of the early days.

There are a number of well-known shaping operations that combine one or more of these processes, or that pass imperceptibly from one into the other. Cutting and drilling often combine the bruising with the incisive methods. Sawing may be done with an abrading edge or with serrations that incise. Boring is likewise accomplished either by cutting or by abrading points and edges.

From this brief analysis of the four simple primal shaping acts, and a consideration of their relations to the mental and physical powers of aural man, as well as to the available materials of his environment, I believe it impracticable to reach any conclusion as to which of these acts would first be consciously employed and intelligently and generally utilized in shaping stone. But there are other criteria which may assist us in the attempt to place them in their proper sequence and relations to culture progress.

## ORDER OF ARTS DEPENDENT ON MEN'S NEEDS.

A study of the elemental shaping acts does not aid us in determining what particular art would take precedence or what variety of art product ought to characterize the earliest periods of human history. If, however, as appears to be the case, the four shaping processes were equally within the reach of man when art began, it does not necessarily follow that all would come into general use at or even near the same time or stage of advancement. It is not the simplicity or discoverability of a shaping process that decides the order of its adoption. The question is rather as to whether or not it is better suited than any other process for supplying human wants. The simplest process possible, though in operation before man's eyes from the beginning to the end of his career, would never come into use did it not subserve the requirements of his existence. The assertion may be safely made, therefore, that, capacity and environment being uniform, the shaping process that would directly supply a permanent or frequently recurring need not otherwise supplied would be the first process generally utilized.

A study of human needs in the auroral days may assist in throwing light upon the order of succession and course of development probably taken by the implement-producing arts. Let us inquire what devices would naturally be called for in supplying primal needs; first the need of food, second the needs of defense and offense, third the needs of shelter and clothing, fourth the needs of transportation. The need of food is a first and ever present incentive to activity, and in early periods man's ingenuity must have been constantly exercised in securing a sufficient and permanent supply. Food getting would lead to the development of varied activities, and call into use all available manual aids. It would certainly in time lead to the multiplication and specialization of utensils, thus opening the way for progress in the shaping arts and the evolution of culture.

It is necessary, then, to inquire as to the probable nature of the artificial devices that food getting and preparing would call into existence. The devices employed would depend on the nature of the food resources available to primitive man. The question is complicated by the fact that environment is far from uniform, and that the food resources vary with the habitat. Yet, considering general conditions only, we are able to reach measurably satisfactory results. Whatsoever man's habitat, his food resources were limited to the products of animal and vegetable life, or to both combined, and, so far as the use of stone is concerned in dealing with these substances, it is safe to say that two classes of implements and only two would be in constant demand. First, roundish or blunt stones would be needed for throwing, striking, crushing, breaking, grinding, etc.; second,

sharp or incisive stones would be demanded for cutting, piercing, digging, scraping, and the like. The same statement may be made with respect to the stone tools applicable to purposes of defense and offense, and available in activities pertaining to shelter, clothing, and transportation.

These two general classes of stone implements fulfilled, so far as stone could fulfill them, all the requirements of man's existence in primal days; and if the question were limited to that of the relative need of blunt and sharp stones in the practice of the arts, we should be compelled to say that no distinction could be made, that one class could not claim precedence over the other in usefulness or in period of utilization.

#### A QUESTION OF SUPPLYING WANTS NOT OTHERWISE SUPPLIED.

But it should be most carefully noted that the question is not one as to the comparative usefulness of these forms of implements, or even of the period of their adoption, but of their production as works of art. Which form would man first be induced to shape for himself, thus adding a group of artificial utensils to his simple list of adapted appliances? If, as seems to be the case, both classes of tools, the blunt and the sharp, are equally essential to man, the question becomes one of natural supply. If nature furnished all that was required in the way of tools, art would not be called on to produce them. If nature supplied one class meagerly and the other abundantly, the meager class would be added to by artificial means. Now if we review the various regions of the world that could have served as the abiding place of auroral man, we find that the rounded stone—the breaking, bruising, grinding stone—is nearly everywhere more readily obtainable than the cutting, piercing stone. The former, being ready at hand, would be at first most freely utilized and for a long time utilized in the natural state, while the latter, being also known and used, yet comparatively rare, would be artificially produced as soon as the capacity to do so was developed.

The artificial sharp stone, the intentionally shaped sharp stone, would thus naturally have precedence as an art form over the intentionally shaped rounded stone. It would probably be the first representative of the shaping art in stone to come into general use. But there are other points to be considered.

#### OPERATION OF THE PRIMAL SHAPING ACTS.

*Incipient stages.*—We must now look more fully into the operation of the four elementary stone-shaping acts—into the beginnings of the arts to which they give rise. It is important to note that the act, the essential element of the process, is not necessarily an index of the simplicity or ease of its utilization. The ease of the first step in a long



and tortuous pathway does not determine the ease of the journey. The ease of the first shaping act does not determine the ease of operating it in such a way as to produce a desired and final result. We observe that in art a desired and definite result may be obtained by a single shaping act, or that a succession of acts may be required. It is also clear that the acts may increase in difficulty as the operations proceed. The intelligence that directs a first act to secure a definite and immediate result may not be equal to the task of directing a series of acts, howsoever simple, aiming at a remote result. In general it may be said that a single-act result would be the first designed result reached and repeated in the shaping arts. A two-act result would follow, and would precede those that depend upon ten, twenty, a hundred, or a thousand acts. Let us examine the four primal stone-shaping processes, fracturing, bruising, rubbing, and cutting, with respect to this point. What is each capable of accomplishing under the simple, elementary conditions that must be assumed for the incipient days of mind and art? Of the four processes, that which produced an immediate, palpable, available result would be first utilized. The fracturing act, the blow upon a brittle stone, would beyond all dispute be that process. Such a blow produces at once one, possibly two, keen-edged tools having forms admirably suited to the common and ever-present needs of the man who must rend flesh, dress skins, cut wood and bone, and dig roots.

On the other hand, the bruising blow, the shaping act by means of which tough stones are shaped, produces an almost imperceptible effect on the stone struck; there is no suggestion of a useful result—a result that could add to the availability of ordinary natural forms. The nearest useful result is far away and obscure, and withal, even when reached, not measurably superior to the forms freely furnished by nature. The dullest mind would be able to understand and utilize the simple fracturing act, but would hardly grasp the nature and possible results of a process so obscure as that of bruising or pecking a piece of rock into definite and unaccustomed shape. This is well illustrated by the almost total failure on the part of students of archaeology to understand the operation of the pecking process in its details until elucidated by recent experiments of Mr. J. D. McGuire. The cultural interval between the general practice of the two processes—flaking and pecking—would cover, in all probability, a considerable period of progress.

*More advanced stages.*—The operation of the shaping processes may be still more fully analyzed and surveyed with relation to actual known implements. The brittle stone to be more than simply fractured must be held in the hand and struck with another stone. The stone to be bruised into shape must also be held in the hand and struck with another stone. The positions may be the same, the shapes the same,

and the act the same. The brittle stone is struck and is broken, producing perhaps a cutting or piercing tool. A second blow produces a second tool, and also modifies the shape of the stone held in the hand. A two-blow tool has thus been made in shaping one-blow tools. By the time ten tools or flakes have been made the portion held in the hand has been shaped by ten blows not directed to its own development, but shaping it adventitiously as a nucleus or core. The results are so well defined and tangible that they could not escape observation, and further experiment would be encouraged. Skill to accomplish soon follows where wants direct the effort, and tangible results are at once attained. From the initial steps of intentional flaking the way would be always open to the achievement of higher and higher results. Advancement could not, however, be rapid; wants had to develop, conceptions ripen, skill increase, and methods differentiate by infinitesimal increments, and the highly specialized flaked implement is possibly as far away from the first designed stroke in flaking stone as the printing press is from the well specialized flaked implement of savage days.

On the other hand, again, the hard, tough stone fitted for elaboration by pecking is struck by the hammer stone, and the only result is a slight crumbling of the surface—a little white dust. There is no suggestiveness, no recognizable step of progress in this result, and even if a hundred blows were struck, no measurable progress would be made toward any tangible result, for a definite conception must be in the mind and a clear notion of how to realize it as well before such result would be possible. So far, then, as the pecking process of itself is concerned, it stands little chance of primal utilization as compared with the flaking process.

But is it possible that a suggestion of the utilization of pecking could come from outside sources, from practice of the simple operations of food preparation? In cracking nuts or pounding seeds (for these must have been among the primal activities), the stones employed would through wear finally exhibit slight concavities. The stones used in the hand would also be modified in shape by striking and rubbing. Could such suggestions possibly give rise to the independent use of these operations in shaping implements of stone? It is not quite clear that the shaping accomplished in the mere routine of use would suggest to the very simple mind the idea of shaping in the abstract, for the shaping in use was adventitious and not necessarily observed. It seems likely that man would go on indefinitely using what nature and adventition supplied unless there was some positive suggestiveness in the results accomplished or some very exceptional exercise of forethought. Certainly the tedious pounding and abrading processes blindly operated in food preparation would, in primal days, stand little chance of being applied to the shaping of tools and utensils

of specialized shapes and uses, and especially to the production of implements with sharp points or cutting edges.

The natural tendency of the pecking blow is to blunt and destroy all edges, and the process would have to be diverted from its natural channels by strong forces to make it produce anything like an edged tool; the conception of such a use would have to be acquired by familiarity with edged tools of other classes and materials. The celt, gouge, and grooved ax are the principal implements made by pecking and grinding in common use among savage peoples. These can not be primal forms, as they represent ripened conceptions, specialized technique, skillful manipulation, and highly differentiated uses and methods of employment. They are practically without ancestry in their own line. Altogether there seems to be little or no art produced by the pecking and grinding processes that could be safely assigned to primal times, save such adventitious shaping as comes from use. An examination of pecked tools reveals the fact that in very many cases the process supplements that of flaking, and it is not impossible that it was first brought into notice and use as a means of getting rid of irregularities and excrescences commonly resulting from imperfect fracture. Pecking would inevitably be suggested in the progress of flaking operations, first, by the effect on the hammer stone, which is modified and specialized by repeated contact with the stone flaked; second, by repeated efforts to remove flakes where the stone happens to be especially refractory. The repeated blows bruise the stone, modifying its shape, and suggesting the possibility of shaping by this means. The abrading processes might also be suggested in similar ways, and especially by the use of flaked tools in operations which modified and polished their edges.

Both the pecking and rubbing processes are especially adapted to elaboration and finish, and are poorly qualified to deal with shapes not already approximate. They did not attain their highest usefulness until superstition and aesthetics became factors in art, encouraging elaboration of form and delicacy of finish.

The accompanying diagram expresses in the most general way my conceptions of the probable relationships of the four shaping processes to the stages of culture progress. The accumulation of additional data will in time enable us to express these relations more fully and with more certainty, but the task is beset with difficulties, for the reason, mainly, that the origin and progress of these arts are not uniform among all peoples. The genetic columns can at best but express generalizations, and are largely hypothetical.

The column representing the development of fracturing arts, so far as it relates to the earliest times, is based on the observations and inferences already presented. The flaking act was a primal act, and the dotted line descending into the pre-human stage indicates this. On

crossing the line—or soon after crossing the line—separating the pre-human from the lowest art stage, I assume that the act was first utilized in the art sense, and that progress began. Being a simple act, and constituting, as operated in fracturing stone, a simple process giving immediate, tangible, and available results, I conceive that its use would increase rapidly through early savage times, dominating the other stone-shaping processes of that period and culminating in late savage

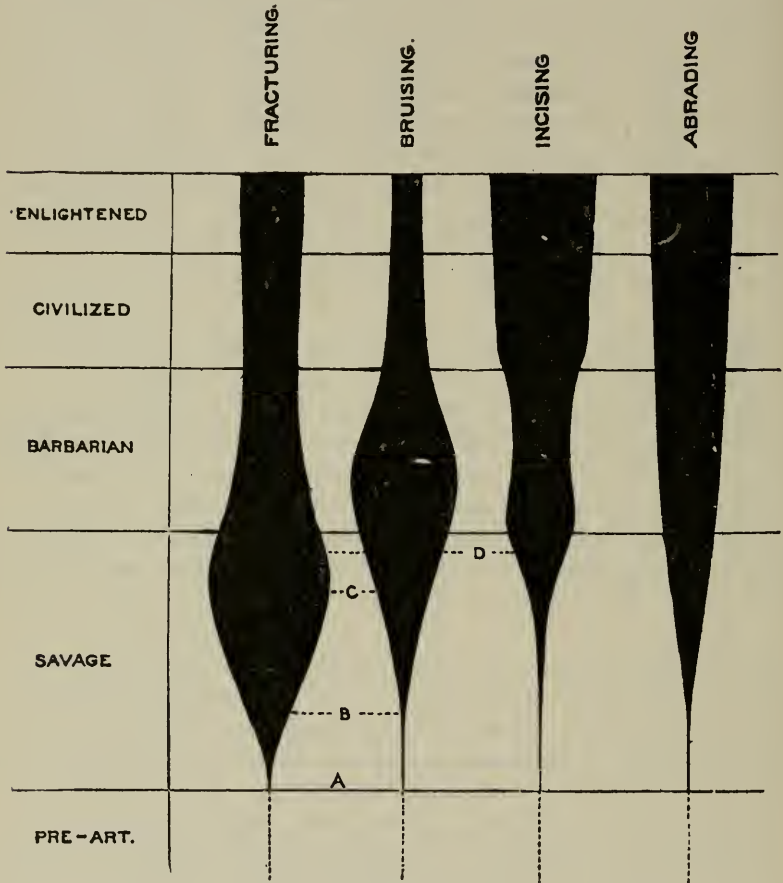

Diagram of relative progress.

times. The employment of the group of processes developed from the simple fracturing act probably decreased to a considerable extent in barbarian times as other processes came into prominence, but it has continued in active use, especially in quarrying and roughing out stone, for all classes of works, architectural, sculptural, and miscellaneous, up to the present day.

The second column is intended to indicate the development of the arts which shape stone by bruising and crumbling its surface. I have

already explained why the process in its simplest form may be considered primal, as having its origin in the pre-human stage of man's history.

Its use in shaping must have been suggested to man at a very early stage of art development, and the lines of the diagram are allowed to expand gradually throughout the savage stages of progress. Observing the obscurity of the effects of the bruising act, the long series of operations necessary in producing the simplest art form known, and the comparative rarity of pecked implements that would fitly characterize the beginning stages of culture, the column has been made to expand very slowly at first, widening rapidly in barbarian times, during which pecked stone seems to have taken the lead among many peoples as a shaping process. The process in its purity appears to have fallen somewhat into disuse in civilized and enlightened times, the acquirement of hard metal tools having given incisive methods a very decided advantage. The fact is, however, that the shaping of hard stone by means of metal chisels partakes of the nature of a compromise between the cutting and bruising processes.

The germ of the incising arts must have come up with man from the state of nature as distinguished from the state of art as expressed in the third column; but the development would be slow, on account, first, of the absence of hard cutting tools, and, second, the absence of stone that could be cut with ease into useful forms. An expanding is indicated in late savage times, during which it is assumed that peoples began to use soft stones for vessels, ornaments, and ceremonial articles. The fact that the soft stones had, as a rule, to be quarried, probably retarded the development of this process. Again, when hard metals came into common use in late barbarian times and in early civilization stone cutting took a prominent place in the arts, and has never since yielded its ground.

The history of the abrading processes is a very interesting one, but as indicated in the diagram there have been few vicissitudes in their progress. Beginning near the threshold of art, they advanced but slowly, serving mainly as an auxiliary to the other processes, being devoted especially to finish and beautification.

#### INFLUENCE OF ENVIRONMENT.

In discussing a scheme of evolution for the shaping arts, I have assumed what I conceive to be average conditions of environment; that is to say, an environment where all ordinary materials are present and available in like proportions. It is apparent, however, that determinations based on such an assumption, even if correctly made out, may not agree with the actual order in the earliest development of art. The environment of the first group of men may have contained all the ordinary elements of stone art, or it may have been without one or

more of these elements. If it did not contain varieties of stone suitable to each process, then there would be a disagreement between the ideal order as here worked out and the real order.

But the race may have been scattered over a wide region at the period of the birth of art, separate groups having distinct ranges of mineral resources. Great diversity of art conditions would thus result. The group deprived of brittle stone would develop its lithic art—no doubt very slowly—through the bruising, grinding, and cutting process, and flaked objects would be practically unknown. The group having only brittle stone would have but meager traces of pecking and cutting operations, and flaked art would have full sway. To cover the ground fully, a separate culture chart would have to be constructed for each group of isolated peoples, for the flaked-stone age of one would occupy the position on the chronologic scale required for the pecked-stone period of the other. But the lines between mineral regions are not usually hard lines, and communities of men, howsoever primitive, are not fixed in habitat. Arts change with change of place and consequent change of environment; and, taking the sum total of the conditions under which a large number of groups of men would live, the mean result must, it seems to me, correspond somewhat closely to that expressed in the diagram, which makes the four primal shaping activities synchronous in origin but indicates different rates of development.

Although expressing the view that the exclusive use of a single shaping process or a group of such processes for a long period seems improbable, I do not wish to antagonize the idea of a flaked-stone period in western Europe. My diagram allows for such a period, covering the space from A to B. That such a period should exist, even in approximate purity, however, until the highest flaked forms were developed, as to C, and until a graphic art equal to the realistic delineation of men and animals on bone and ivory, say to D in the incising column, should exist and flourish, is, in view of the considerations brought forward in this paper, not within the range of probability.

#### CONCLUSION.

This brief study can not assume to be more than an outline of the general subject. Prolonged investigation is essential to the completion of such a work. I have sought means of approaching and examining that part of primeval history not within the ordinary scope of research. Through an analysis of the elementary shaping processes—the agencies by means of which man gained his sway over nature—I have undertaken to determine the order in which these operations would probably originate and develop, and thus to place the varied art products to which they give rise in their proper relations with one another and with the successive stages of unwritten history.

Such studies can not add greatly to our actual knowledge of events, although they may serve a good purpose in confirming or discrediting conclusions reached by other means, but they will materially assist in preparing the way for an intelligent consideration of those meager shreds of history that extend, like the edge of a frayed garment, back into the realms of the unknown.

The present study suggests the need of conservatism in interpreting the scattered records available to prehistoric archaeology. Where the conditions under which men have lived are so varied, there must needs be great diversity in art achievement, and the order of the steps of human progress established in one region can not be applied with safety to another or to all, notwithstanding strong tendencies toward uniformity. Regional art groups must be examined primarily in the light of local conditions, and general results are to be reached by a comparative study of these special results. The actual order of progress of the race in the primal stages can never be absolutely known; and thus it is that hypothesis is called upon to supply an order of events consistent with what is known of the laws of life and art.





## BOOMERANGS.<sup>a</sup>

---

By GILBERT T. WALKER.

---

Boomerangs may be studied for their anthropological interest as examples of primitive art<sup>b</sup> or for the manner in which they illustrate dynamical principles.<sup>c</sup> But there is extraordinary fascination in making and throwing them, and in watching the remarkable and always graceful curves described in their flight. Accordingly, my chief object in the following paper has been to diminish the practical difficulties of the subject by giving some of the results of ten years' experimental acquaintance with it.

The Australian weapons vary enormously in shape and size, while the skill of the natives in throwing them is great in some districts and very small in others. The marvelous flights that were described by former travelers are but rarely seen to-day, and although it is undeniable that many a native can make a boomerang go 80 meters away before returning to his feet, I know of only one trustworthy account of a much more sensational throw.<sup>d</sup> In this the boomerang described five circles in the air, traveling to a distance of about 90 meters from the thrower and rising to a height of 45 meters.

For present purposes it will be convenient to consider two types of implements. The first (fig. 1) is about 80 cm. in length, measured along the curve, is bent (at B) almost to a right angle, and has the cross section shown in fig. 2. It is about 6.5 cm. wide and 1 cm. thick in the center at B, and the dimensions of the cross section diminish slightly toward the ends A and C. The weight is about 230 grams. The arms are twisted from the plane A B C after the manner of the

---

<sup>a</sup> Reprinted from *Nature*, No. 1657, vol. 64, August 1, 1901, in which appears the following note: "This paper is here published by permission of the editors of the *Physikalische Zeitschrift*, for which it was originally written. A German translation has appeared in that journal, and from its publishers the accompanying illustrations have been obtained."

<sup>b</sup> *The Native Tribes of Central Australia*, by B. Spencer and F. J. Gillen (1899), ch. xix.

<sup>c</sup> E. O. Erdmann, *Ann. d. Phys. u. Chemie*, Vol. CXXXVII, p. 1 (1869); E. Gerlach, *Zeitschr. d. D. Vereins z. Förd. d. Luftschiffahrt*, Heft 3 (1886); G. T. Walker, *London, Phil. Trans.*, Vol. CXC, p. 23 (1897).

<sup>d</sup> Mr. A. W. Howitt, *Nature*, July 20, 1876.

sails of a windmill, being rotated through  $2^\circ$  or  $3^\circ$  in the direction of a right-handed screw about the lines B A, B C, as axes. This

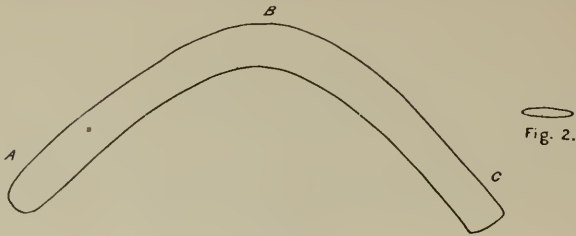

FIG. 1.

deviation from the plane is subsequently referred to as the "twist," and the peculiarity that, as seen in the cross section of fig. 2, one face is more rounded than the other, is called the "rounding."

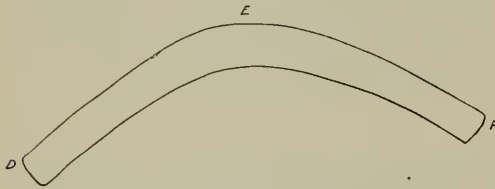

FIG. 3.

Boomerangs of the second type (fig. 3) are about 70 cm. long and 7 cm. wide, and have a cross section similar to that of fig. 2. The "twist" is in the opposite direction, involving a left-handed rotation of about  $3^\circ$ . The axes of rotation are now D E, F E instead of E D, E F.

#### RETURNING FLIGHTS.

An implement of the first type is held with the more rounded side to the left and the concave edge forward. It is thrown, with plane vertical, in a horizontal direction, and as much rotation as possible is given to it. The plane of rotation does not remain parallel to its original direction, but has an angular velocity (1) about the direction of translation, and (2) about a line in its plane perpendicular to this.

The effect of (2) is that the path curls to the left, while owing to (1) the plane of rotation inclines over to the right (i. e., rotates in the direction of the hands of a clock facing the thrower), and its inclination to the vertical becomes comparable with  $30^\circ$  in two seconds. The angular velocity (2) will now imply that the path bends upward as well as horizontally round to the left.

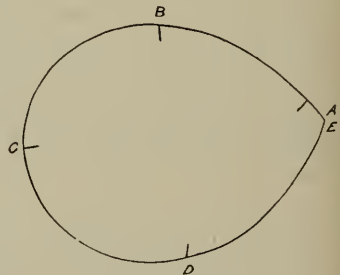

FIG. 4.—Plan.

When the boomerang has described a nearly complete circle its pace has diminished, and it falls to the ground near the thrower. (See figs. 4, 5, in which projections on a horizontal and on a vertical plane are

given. The direction of the axis of rotation is indicated by giving the projections of a line of constant length measured along it. The scale of these diagrams is about 1:1000.)

The angular velocity (1) is increased by an increase of twist and by an increase of rounding; it also increases when  $\cos \theta$  increases, where  $\theta$  is the inclination of the plane of rotation to the horizontal. The curling to the left (2) is increased by an increase of twist, or of  $\cos \theta$ , and, in general, by an increase of rounding.

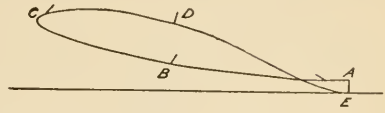

FIG. 5.—Elevation through C A.

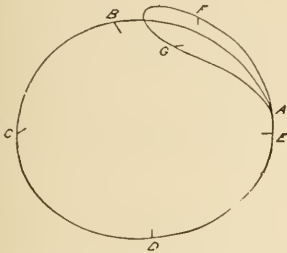

FIG. 6.—Plan.

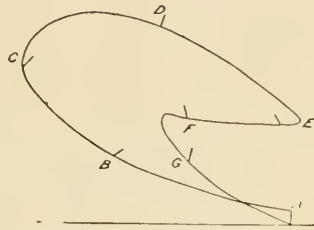

FIG. 7.—Elevation through C E.

If it be desired that the boomerang should describe a second circle in front of the thrower (figs. 6, 7), it must be thrown much harder, so that when one circle has been described it may still have sufficient forward velocity. When the projectile has described the first circle and is over the thrower's head, the axis of rotation must point in an upward direction in front of him; if it pointed behind him the subsequent path would be behind his back, and a figure of 8 (figs. 8, 9) would become possible. For a path with a second loop in front of the

thrower he should accordingly choose a boomerang with much twist and much rounding, and throw it with his body leaning over to the left, so that the angle  $\theta$  between the axis of rotation and the vertical may be slightly in excess of a right angle. The increased twist will mean that the first circle has a smaller circumference and that there will be more pace left after it has been described, and the increased rounding will keep the plane of rotation from becoming horizontal too soon.

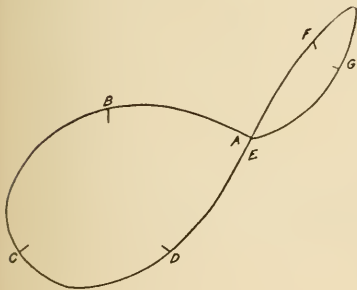

FIG. 8.—Plan.

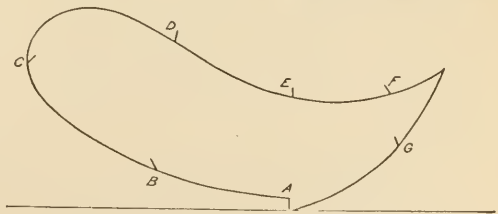

FIG. 9.—Elevation through C A G.

For a figure of 8 we should require less rounding, or we might give more spin in throwing, and aim a little uphill, with  $\theta$  rather less

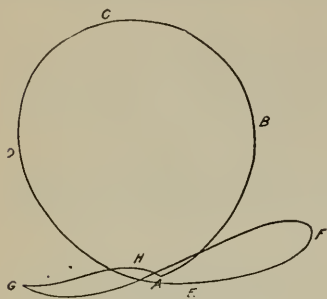

FIG. 10.—Plan.

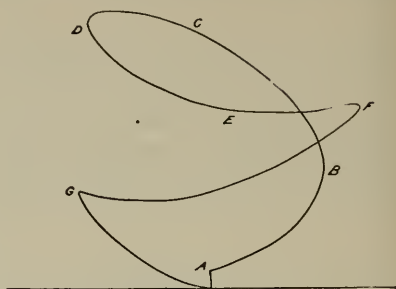

FIG. 11.—Elevation through G F.

than a right angle. There are so many elements capable of variation that nothing but experience can teach how to get the best results with any particular boomerang.

The most complex path that the author has succeeded in effecting is that of figs. 10 and 11. But it is certain that these fall far short of what is done by skillful natives of Australia.

If the angle between the arms is increased and the twist and rounding unaltered, the angular velocity (1) is increased, and it becomes easier to make a second loop behind than in front. If the angle exceeds  $150^\circ$  the angular velocity of the first kind is so large that it is very hard to get a return at all.



FIG. 12.—Plan.

When the twist is left-handed and the angle large we have a specimen of the second type (fig. 3), and it must be thrown with the more rounded side uppermost and the plane of rotation inclined at between  $30^\circ$  and  $60^\circ$  to the horizontal (i. e.,  $30^\circ < \theta < 60^\circ$ ); the angle of projection (i. e., inclination to the horizon of the initial velocity of translation) must be comparable with  $45^\circ$ .

The uphill path is nearly straight until the forward velocity becomes small; the projectile then returns along a track close to that of the ascent (figs. 12 and 13).

#### NONRETURNING FLIGHTS.

A good boomerang of the second type will travel an immense distance in a nearly straight line if properly thrown. The motion should resemble that of an aeroplane or flying machine; the plane of rotation must remain nearly horizontal,

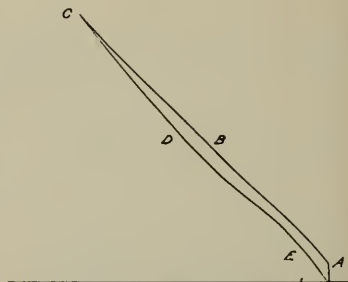

FIG. 13.—Elevation through A C.

though slightly uphill, and the trajectory must be flat. There will thus be an upward pressure of air on the under surface of the implement, and the force of gravity will be counteracted as long as there is sufficient forward velocity. The boomerang is thrown very slightly uphill, the angle of projection not being greater than  $12^\circ$ ; the rounded side is uppermost and  $\theta$  is initially  $30^\circ$ . The plane of rotation soon appears to the thrower to become approximately horizontal, and it remains so during the flight; the projectile rises to a height of about 12 meters from the ground and travels in a nearly straight path until its forward velocity is almost exhausted; it then strikes the earth at a distance of about 130 meters from the thrower.

It will be seen that the angular velocity (1) is at first small and positive, and that it subsequently disappears; the angular velocity (2) is small throughout. These results are due to the left-handed twist and the rounding.

Considerable accuracy, both in making and in throwing, is necessary if the best results are to be obtained. If the plane of rotation slopes downward to one side, the boomerang will slide down in the inclined plane of rotation; thus the path will be bent and materially shortened. The correct relation has to be found between the twist, the rounding, the angle between the arms of the boomerang, the density of its material, and the amounts and directions of its initial linear and angular velocities. An illustration of this is afforded by the first specimen of this type that I have made; it travels farther against the wind than with it. In the former case the boomerang keeps quite low, scarcely rising higher than 6 meters, and being retarded very little by frictional resistance, travels about 125 meters; in the latter case the body spends its energy in running uphill to a height of about 15 meters, and falls to the ground at a distance of about 90 meters.

It is rather difficult to give sufficient spin to keep the motion stable through a long flight, and I have found it advantageous to wind round the wood about 60 grams weight of copper wire in three equal portions, of which one is in the middle and one near each end. This materially increases the moment of inertia about the center of gravity without interfering seriously with other details. I have thrown a loaded boomerang of this type 167 meters, and my range with a spherical ball of half the weight is only 63 meters.

#### MODE OF MANUFACTURE.

A block of straight-grained ash about 90 cm. long, 7 cm. (or 7.5 cm.) thick, and of width not less than 7 cm., is taken. The block is soaked in steam, bent to the requisite shape and held in this shape until cool and dry. It is then sawn into strips 1.3 cm. thick. After sufficient time has elapsed for the wood to be seasoned, each strip is trimmed into a boomerang, the most useful tool in general being a spokeshave. It is very important that the outer edge, at any rate in the neighborhood

of the bend, should follow the grain of the wood. When the projectile falls hard upon one end the stress near the center is very severe, and any point at which the direction of the grain meets the convex edge obliquely is likely to develop a split and ultimately a breakage.

It is better to cut the material to its final twisted shape rather than to impart the twist by another steaming and bending. Considerable care is required in the process, for the removal of a layer of wood a millimeter thick in such a way as to increase or diminish the twist will cause a marked difference in the flight. It will be found to facilitate throwing to cut that end of the boomerang which is held in the hand to the somewhat square form shown at the right hand of figs. 1 and 3.

There is some difficulty in avoiding warping, for boomerangs are less likely to get broken if thrown when the ground is damp and soft, and under these circumstances the moisture is likely to be absorbed by the wood. It is of great advantage, therefore, to make the surface of the implements very smooth with fine glass paper and to saturate them with linseed oil. The additional density thereby produced is also of service in that it diminishes the effect of the frictional resistance of the air.

I have used artificially bent oak as a material, but have not found it as heavy or as strong as ash. Oak branches that are naturally bent are not hard to procure, but boomerangs made from them are liable to break at places where there are knots or irregularities in the grain of the wood.

#### EVOLUTION.

Boomerangs of every variety of shape are still to be found in Australia, and it appears impossible to get direct historical evidence as to the nature of the successive stages of development. But if speculation be allowed, the following series may be suggested:

First, we should have a clumsy kind of wooden sword, curved, but without rounding or twist, and with one end roughened to form a handle; when the intended victim was out of reach it would be natural to throw the weapon, and at short ranges it would be extremely effective. Bad workmanship would involve the frequent production of implements of which one side was more rounded than the other, and it would soon be found that these missiles, when thrown with the rounded side uppermost, traveled much farther and straighter than the former.

Boomerangs of this character vary in length from 50 to 110 cm., and in weight from 200 to 1,250 grams. They are, for the most part, twisted in a manner that seems quite fortuitous, and form the enormous majority of the present native implements. Light specimens with a slight left-handed twist may have a fairly straight trajectory of 100 meters, and may return if aimed much uphill, especially

when thrown against a wind.. Those which are bent through a large enough angle and happen to be twisted (either by carelessness in manufacture or by subsequent warping<sup>a</sup>) after the manner of a right-handed screw are returning boomerangs of the first type. In many of these the twist is so large as to be conspicuous, and when once the connection between the form and the return flight has been noticed, the process of development is complete.

---

<sup>a</sup>This may be illustrated by the fact that when the author first made boomerangs he was only aware of the need for rounding; but the first two specimens that he constructed happened to have right-handed twist and returned admirably.





THE POSSIBLE IMPROVEMENT OF THE HUMAN BREED  
UNDER THE EXISTING CONDITIONS OF LAW AND  
SENTIMENT.<sup>a</sup>

---

By FRANCIS GALTON, D. C. L., D. Sc., F. R. S.,

*London.*

---

In fulfilling the honorable charge that has been intrusted to me of delivering the Huxley lecture, I shall endeavor to carry out what I understand to have been the wish of its founders, namely, to treat broadly some new topic belonging to a class in which Huxley himself would have felt a keen interest, rather than to expatiate on his character and the work of his noble life.

That which I have selected for to-night is one which has occupied my thoughts for many years, and to which a large part of my published inquiries have borne a direct though silent reference. Indeed, the remarks I am about to make would serve as an additional chapter to my books on Hereditary Genius and on Natural Inheritance. My subject will be "The possible improvement of the human race under the existing conditions of law and sentiment." It has not hitherto been approached along the ways that recent knowledge has laid open, and it occupies in consequence a less dignified position in scientific estimation than it might. It is smiled at as most desirable in itself and possibly worthy of academic discussion, but absolutely out of the question as a practical problem. My aim in this lecture is to show cause for a different opinion. Indeed, I hope to induce anthropologists to regard human improvement as a subject that should be kept openly and squarely in view, not only on account of its transcendent importance, but also because it affords excellent but neglected fields for investigation. I shall show that our knowledge is already sufficient to justify the pursuit of this, perhaps the grandest of all objects, but that we know less of the conditions upon which success depends than we might and ought to ascertain. The limits of our knowledge and of our ignorance will become clearer as we proceed.

---

<sup>a</sup>The second Huxley Lecture of the Anthropological Institute of Great Britain and Ireland, delivered October 29, 1901. Printed in *Nature*, November 1, 1901.

## HUMAN VARIETY.

The natural character and faculties of human beings differ at least as widely as those of the domesticated animals, such as dogs and horses, with whom we are familiar. In disposition some are gentle and good-tempered, others surly and vicious; some are courageous, others timid; some are eager, others sluggish; some have large powers of endurance, others are quickly fatigued; some are muscular and powerful, others are weak; some are intelligent, others stupid; some have tenacious memories of places and persons, others frequently stray and are slow at recognizing. The number and variety of aptitudes, especially in dogs, is truly remarkable; among the most notable being the tendency to herd sheep, to point, and to retrieve. So it is with the various natural qualities that go toward the making of civic worth in man. Whether it be in character, disposition, energy, intellect, or physical power, we each receive at our birth a definite endowment, allegorized by the parable related in St. Matthew, some receiving many talents, others few; but each person being responsible for the profitable use of that which has been intrusted to him.

## DISTRIBUTION OF QUALITIES IN A NATION.

Experience shows that while talents are distributed in endless different degrees, the frequency of those different degrees follows certain statistical laws, of which the best known is the normal law of frequency. This is the result whenever variations are due to the combined action of many small and different causes, whatever may be the causes and whatever the object in which the variations occur, just as twice 2 always makes 4, whatever the objects may be. It therefore holds true with approximate precision for variables of totally different sorts, as, for instance, stature of man, errors made by astronomers in judging minute intervals of time, bullet marks around the bull's-eye in target practice, and differences of marks gained by candidates at competitive examinations. There is no mystery about the fundamental principles of this abstract law; it rests on such simple fundamental conceptions as, that if we toss 2 pence in the air they will, in the long run, come down one head and one tail twice as often as both heads or both tails. I will assume, then, that the talents, so to speak, that go to the formation of civic worth are distributed with rough approximation according to this familiar law. In doing so, I in no way disregard the admirable work of Prof. Karl Pearson on the distribution of qualities, for which he was adjudged the Darwin medal of the Royal Society a few years ago. He has amply proved that we must not blindly trust the normal law of frequency; in fact, that when variations are minutely studied they rarely fall into that perfect symmetry about the mean value, which is one of its consequences. Nevertheless, my conscience is clear

in using this law in the way I am about to. I say that *if* certain qualities vary normally, such and such will be the results; that these qualities are of a class that are found, whenever they have been tested, to vary normally to a fair degree of approximation, and consequently we may infer that our results are trustworthy indications of real facts.

A talent is a sum whose exact value few of us care to know, although we all appreciate the inner sense of the beautiful parable. I will, therefore, venture to adapt the phraseology of the allegory to my present purpose by substituting for "talent" the words "normal talent." The value of this normal talent in respect to each and any specified quality or faculty is such that one-quarter of the people receive for their respective shares more than one normal talent *over and above* the average of all the shares. Our normal talent is therefore identical with what is technically known as the "probable error." Therefrom the whole of the following table starts into life, evolved from that of the "*probability integral*."

TABLE I.—Normal distribution (to the nearest per ten thousand and to the nearest per hundred).

-4°.		-3°.	-2°.	-1°.	M.	+1°.	+2°.	+3°.	+4°.	Total.
r and below.	<i>u.</i>	<i>t.</i>	<i>s.</i>	<i>r.</i>	R.	S.	T.	U.	V and above.	
35	180	672	1,613	2,500	2,500	1,613	672	180	35	10,000
	<u>2</u>	7	16	25	25	16	7	<u>2</u>		100

It expresses the distribution of any normal quality, or any group of normal qualities, among 10,000 persons in terms of the normal talent. The M in the upper line occupies the position of mediocrity, or that of the average of what all have received; the +1°, +2°, etc., and the -1°, -2°, etc., refer to normal talents. These numerals stand as graduations at the heads of the vertical lines by which the table is divided. The entries between the divisions are the numbers per 10,000 of those who receive sums between the amounts specified by those divisions. Thus, by the hypothesis, 2,500 receive more than M but less than M+1°, 1,613 receive more than M+1° but less than M+2°, and so on. The terminals have only an inner limit; thus, 35 receive more than 4°, some to perhaps a very large but indefinite amount. The divisions might have been carried much further, but the numbers in the classes between them would become less and less trustworthy. The left half of the series exactly reflects the right half. As it will be useful henceforth to distinguish these classes, I have used the *capital* or large letters, R, S, T, U, V, for those above mediocrity and corresponding *italic* or small letters, *r*, *s*, *t*, *u*, *v*, for those below mediocrity, *r* being the counterpart of R, *s* of S, and so on.

In the lowest lines the same values are given, but more roughly, to the nearest whole percentage.

It will assist in comprehending the values of different grades of civic worth to compare them with the corresponding grades of adult male stature in our nation. I will take the figures from my *Natural Inheritance*, premising that the distribution of stature in various peoples has been well investigated and shown to be closely normal. The average height of the adult males, to whom my figures refer, was nearly 5 feet 8 inches, and the value of their "normal talent" (which is a measure of the spread of distribution) was very nearly  $1\frac{3}{4}$  inches. From these data it is easily reckoned that class U would contain men whose heights exceed 6 feet  $1\frac{1}{4}$  inches. Even they are tall enough to overlook a hatless mob, while the higher classes, such as V, W, and X, tower above it in an increasingly marked degree. So the civic worth (however that term may be defined) of U-class men, and still more of V-class, are notably superior to the crowd, though they are far below the heroic order. The rarity of a V-class man in each specified quality or group of qualities is as 35 in 10,000, or, say, for the convenience of using round numbers, as 1 to 300. A man of the W class is ten times rarer, and of the X class rarer still; but I shall avoid giving any more exact definition of X than as a value considerably rarer than V. This gives a general but just idea of the distribution throughout a population of each and every quality taken separately so far as it is normally distributed. As already mentioned, it does the same for *any* group of normal qualities; thus, if marks for classics and for mathematics were severally normal in their distribution, the combined marks gained by each candidate in both those subjects would be distributed normally also, this being one of the many interesting properties of the law of frequency.

#### COMPARISON OF THE NORMAL CLASSES WITH THOSE OF MR. BOOTH.

Let us now compare the normal classes with those into which Mr. Charles Booth has divided the population of all London, in a way that corresponds not unfairly with the ordinary conception of grades of civic worth. He reckons them from the lowest upward, and gives the numbers in each class for East London. Afterwards he treats all London in a similar manner, except that sometimes he combines two classes into one and gives the joint result. For my present purpose I had to couple them somewhat differently, first disentangling them as I best could. There seemed no better way of doing this than by assigning to the members of each couplet the same proportions that they had in East London. Though this was certainly not accurate, it is probably not far wrong. Mr. Booth has taken unheard-of pains in this great work of his to arrive at accurate results, but he emphatically says that his classes can not be separated sharply from one another. On the

contrary, their frontiers blend, and this justifies me in taking slight liberties with his figures. His class A consists of criminals, semi-criminals, loafers, and some others, who are in number at the rate of 1 per cent in all London—that is, 100 per 10,000, or nearly three times as many as the *v* class; they therefore include the whole of the *v* and spread upward into the *u*. His class B consists of very poor persons who subsist on casual earnings, many of whom are inevitably poor from shiftlessness, idleness, or drink. The numbers in this and the A class combined closely correspond with those in *t* and all below *t*.

Class C are supported by intermittent earnings; they are a hard-working people, but have a very bad character for improvidence and shiftlessness. In class D the earnings are regular, but at the low rate of 21 shillings or less a week, so none of them rise above poverty, though none are very poor. D and C together correspond to the whole of *s* combined with the lower fifth of *v*. The next class, E, is the largest of any, and comprises all those with regular standard earnings of 22 to 30 shillings a week. This class is the recognized field for all forms of cooperation and combination; in short, for trades unions. It corresponds to the upper four-fifths of *v* and the lower four-fifths of R. It is, therefore, essentially the mediocere class, standing as far below the highest in civic worth as it stands above the lowest class with its criminals and semicriminals. Next above this large mass of mediocrity comes the honorable class *F*, which consists of better-paid artisans and foremen. These are able to provide adequately for old age, and their sons become clerks, etc. *G* is the lower middle class of shopkeepers, small employers, clerks, and subordinate professional men, who as a rule are hard-working, energetic, and sober. F and G combined correspond to the upper fifth of R and the whole of S, and are, therefore, a counterpart to D and C. All above G are put together by Mr. Booth into one class, H, which corresponds to our T, U, V, and above, and is the counterpart of his two lowermost classes, A and B. So far, then, as these figures go, civic worth is distributed in fair approximation to the normal law of frequency. We also see that the classes *t*, *u*, *v*, and below are undesirables.

#### WORTH OF CHILDREN.

The brains of the nation lie in the higher of our classes. If such people as would be classed W or X could be distinguishable as children and procurable by money in order to be reared as Englishmen, it would be a cheap bargain for the nation to buy them at the rate of many hundred or some thousands of pounds per head. Dr. Farr, the eminent statistician, endeavored to estimate the money worth of an average baby born to the wife of an Essex laborer and thenceforward living during the usual time and in the ordinary way of his class. Dr. Farr,

with accomplished actuarial skill, capitalized the value at the child's birth of two classes of events, the one the cost of maintenance while a child and when helpless through old age, the other its earnings as boy and man. On balancing the two sides of the account the value of the baby was found to be £5. On a similar principle, the worth of an X-class baby would be reckoned in thousands of pounds. Some such "talented" folk fail, but most succeed, and many succeed greatly. They found great industries, establish vast undertakings, increase the wealth of multitudes, and amass large fortunes for themselves. Others, whether they be rich or poor, are the guides and light of the nation, raising its tone, enlightening its difficulties, and imposing its ideals. The great gain that England received through the immigration of the Huguenots would be insignificant to what she would derive from an annual addition of a few hundred children of the classes W and X. I have tried, but not yet succeeded to my satisfaction, to make an approximate estimate of the worth of a child at birth according to the class he is destined to occupy when adult. It is an eminently important subject for future investigators, for the amount of care and cost that might profitably be expended in improving the race clearly depends on its result.

#### DESCENT OF QUALITIES IN A POPULATION.

Let us now endeavor to obtain a correct understanding of the way in which the varying qualities of each generation are derived from those of its predecessor. How many, for example, of the V class in the offspring come respectively from the V, U, T, S, and other classes of parentage? The means of calculating this question for a normal population are given fully in my *Natural Inheritance*. There are three main senses in which the word parentage might be used. They differ widely, so the calculations must be modified accordingly. (1) The amount of the quality or faculty in question may be known in each parent. (2) It may be known in only one parent. (3) The two parents may belong to the same class, a V-class father in the scale of male classification always marrying a V-class mother, occupying identically the same position in the scale of female classification.

I select this last case to work out as being the one with which we shall here be chiefly concerned. It has the further merit of escaping some tedious preliminary details about converting female faculties into their corresponding male equivalents, before men and women can be treated statistically on equal terms. I shall assume in what follows that we are dealing with an ideal population, in which all marriages are equally fertile, and which is statistically the same in successive generations, both in numbers and in qualities, so many per cent being always this, so many always that, and so on. Further, I shall take no notice of offspring who die before they reach the age of marriage, nor

shall I regard the slight numerical inequality of the sexes, but will simply suppose that each parentage produces one couplet of grown-up filials, an adult man and an adult woman.

The result is shown to the nearest whole per thousand in the diagram up to "U and above." It may be read either as applying to fathers and their sons when adult, or to mothers and their daughters when adult, or, again, to parentages and filial couplets. I will not now attempt to explain the details of the calculation to those to whom these methods are new. Those who are familiar with them will easily understand the

## STANDARD SCHEME OF DESCENT

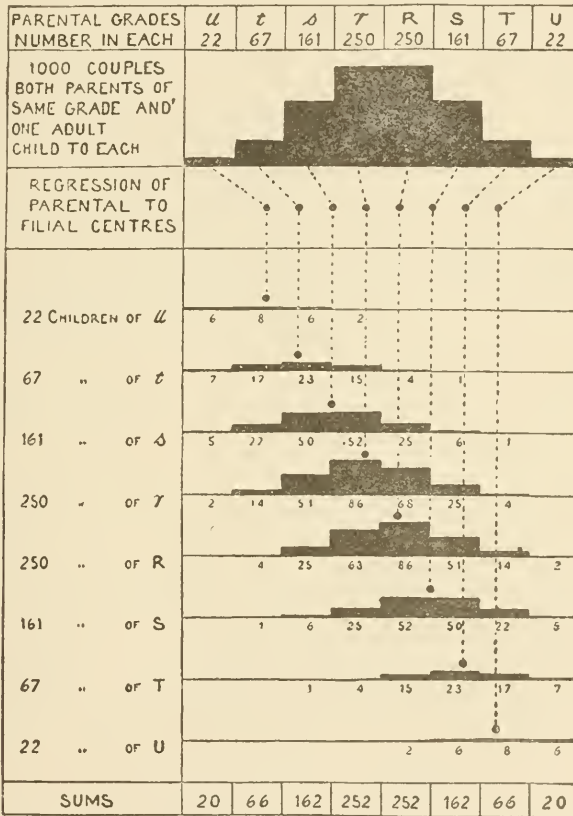

exact process from what follows. There are three points of reference in a scheme of descent, which may be respectively named "mid-parental," "genetic," and "filial" centers. In the present case of both parents being alike, the position of the mid-parental center is identical with that of either parent separately. The position of the filial center is that from which the children disperse. The genetic center occupies the same position in the parental series that the filial center does in the filial series. Natural Inheritance contains abundant proof, both observational and

theoretical, that the genetic center is not and can not be identical with the parental center, but is always more mediocre, owing to the combination of ancestral influences—which are generally mediocre—with the purely parental ones. It also shows that the regression from the parental to the genetic center, in the case of stature at least, would amount to two-thirds under the conditions we are now supposing. The regression is indicated in the diagram by converging lines which are directed toward the same point below, but are stopped at one-third of the distance on the way to it. The contents of each parental class are supposed to be concentrated at the foot of the median axis of that class, this being the vertical line that divides its contents into equal parts. Its position is, approximately, but not exactly, halfway between the divisions that bound it, and is as easily calculated for the extreme classes, which have no outer terminals, as for any of the others. These median points are respectively taken to be the positions of the parental centers of the whole of each of the classes; therefore the positions attained by the converging lines that proceed from them at the points where they are stopped represent the genetic centers. From these the filials disperse to the right and left with a “spread” that can be shown to be three-quarters that of the parentages. Calculation easily determines the number of the filials that fall into the class in which the filial center is situated and of those that spread into the classes on each side. When the parental contributions from all the classes to each filial class are added together they will express the distribution of the quality among the whole of the offspring. Now it will be observed in the table that the numbers in the classes of the offspring are identical with those of the parents, when they are reckoned to the nearest whole parentage, as should be the case according to the hypothesis. Had the classes been narrower and more numerous, and if the calculations had been carried on to two more places of decimals, the correspondence would have been identical to the nearest ten thousandth. It was unnecessary to take the trouble of doing this, as the table affords a sufficient basis for what I am about to say. Though it does not profess to be more than approximately true in detail, it is certainly trustworthy in its general form, including as it does the effects of regression, filial dispersion, and the equation that connects a parental generation with a filial one when they are statistically alike. Minor corrections will be hereafter required, and can be applied when we have a better knowledge of the material. In the meantime it will serve as a standard table of descent from each generation of a people to its successor.

#### ECONOMY OF EFFORT.

I shall now use the table to show the economy of concentrating our attention upon the highest classes. We will therefore trace the origin of the V class, which is the highest in the table. Of its 34 or 35 sons



6 come from V parentages, 10 from U, 10 from T, 5 from S, 3 from R, and none from any class below R; but the numbers of the contributing parentages have also to be taken into account. When this is done, we see that the lower classes make their scores owing to their quantity and not to their quality, for while 35 V-class parents suffice to produce 6 sons of the V class, it takes 2,500 R-class fathers to produce 3 of them. Consequently, the richness in produce of V-class parentages is to that of the R class in an inverse ratio, or as 143 to 1. Similarly, the richness in produce of V-class children from parentages of the classes U, T, S, respectively, is as 3,  $11\frac{1}{2}$ , and 55 to 1. Moreover, nearly one-half of the produce of V-class parentages are V or U taken together, and nearly three-quarters of them are either V, U, or T. If, then, we desire to increase the output of V-class offspring, by far the most profitable parents to work upon would be those of the V class, and in a threefold less degree those of the U class.

When both parents are of the V class the quality of parentages is greatly superior to those in which only one parent is a V. In that case the regression of the genetic center goes twice as far back toward mediocrity, and the spread of the distribution among filials becomes nine-tenths of that among the parents, instead of being only three-quarters. The effect is shown in Table II.

TABLE II.—*Distribution of sons.*—(1) One parent of class V, the other unknown; (2) both parents of class V (from Table II, with decimal point and an 0).

	Distribution of sons.								Total.
	t.	s.	r.	R.	S.	T.	U.	V.	
(1) One V parent.....	0.3	1.2	3.5	7.9	9.6	7.5	3.6	1.3	34.3
(2) Two V parents.....				3.0	5.0	10.0	10.0	6.0	34.0

Position of the filial center of (1)=1.44, of (2)=2.89; when both parents are T it=1.58.

There is a difference of fully two divisions in the position of the genetic center, that of the single V parentage being only a trifle nearer mediocrity than that of the double T. Hence it would be bad economy to spend much effort in furthering marriages with a high class on only one side.

#### MARRIAGE OF LIKE TO LIKE.

In each class of society there is a strong tendency to intermarriage, which produces a marked effect in the richness of brain power of the more cultured families. It produces a still more marked effect of another kind at the lowest step of the social scale, as will be painfully evident from the following extracts from the work of Mr. C. Booth (i, 38), which refer to his class A, who form, as has been said, the lowermost third of our "v and below." "Their life is the life of savages, with vicissitudes of extreme hardship and occasional excess. From them come the battered figures who slouch through the streets and

play the beggar or the bully. They render no useful service; they create no wealth, more often they destroy it. They degrade whatever they touch, and as individuals are perhaps incapable of improvement; \* \* \* but I do not mean to say that there are not individuals of every sort to be found in the mass. Those who are able to wash the mud may find some gems in it. There are at any rate many very piteous cases. Whatever doubt there may be as to the exact numbers of this class, it is certain that they bear a very small proportion to the rest of the population, or even to class B, with which they are mixed up and from which it is at times difficult to separate them. \* \* \* They are barbarians, but they are a handful." He says further: "It is much to be desired and to be hoped that this class may become less hereditary in its character; there appears to be no doubt that it is now hereditary to a very considerable extent."

Many who are familiar with the habits of these people do not hesitate to say that it would be an economy and a great benefit to the country if all habitual criminals were resolutely segregated under merciful surveillance and peremptorily denied opportunities for producing offspring. It would abolish a source of suffering and misery to a future generation, and would cause no unwarrantable hardship in this.

#### DIPLOMAS.

It will be remembered that Mr. Booth's classification did not help us beyond classes higher than S in civic worth. If a strong and widely felt desire should arise to discover young men whose position was of the V, W, or X order, there would not be much difficulty in doing so. Let us imagine for a moment what might be done in any great university where the students are in continual competition in studies, in athletics, or in public meetings, and where their characters are publicly known to associates and to tutors. Before attempting to make a selection, acceptable definitions of civic worth would have to be made in alternative terms, for there are many forms of civic worth. The number of men of the V, W, or X classes, whom the university was qualified to contribute annually, must also be ascertained. As was said, the proportion in the general population of the V class to the remainder is as 1 to 300, and that of the W class as 1 in 3,000. But students are a somewhat selected body, because the cleverest youths, in a scholastic sense, usually find their way to universities. A considerably high level, both intellectually and physically, would be required as a qualification for candidature. The limited number who had not been automatically weeded away by this condition might be submitted in some appropriate way to the independent votes of fellow students on the one hand and of tutors on the other, whose ideals of character and merit necessarily differ. This ordeal would reduce the possible winners to a very small number, out of which an independent committee

might be trusted to make the ultimate selection. They would be guided by personal interviews. They would take into consideration all favorable points in the family histories of the candidates, giving appropriate hereditary weight to each. Probably they would agree to pass over unfavorable points, unless they were notorious and flagrant, owing to the great difficulty of ascertaining the real truth about them. Ample experience in making selections has been acquired even by scientific societies, most of which work well, including perhaps the award of their medals, which the fortunate recipients at least are tempted to consider judicious. The opportunities for selecting women in this way are unfortunately fewer, owing to the smaller number of female students, between whom comparisons might be made on equal terms. In the selection of women, when nothing is known of their athletic proficiency, it would be especially necessary to pass a high and careful medical examination; and as their personal qualities do not usually admit of being tested so thoroughly as those of men, it would be necessary to lay all the more stress on hereditary family qualities, including those of fertility and prepotency.

#### CORRELATION BETWEEN PROMISE IN YOUTH AND SUBSEQUENT PERFORMANCE.

No serious difficulty seems to stand in the way of classifying and giving satisfactory diplomas to youths of either sex, supposing there were a strong demand for it. But some real difficulty does lie in the question, Would such a classification be a trustworthy forecast of qualities in later life? The scheme of descent of qualities may hold good between the parents and the offspring at similar ages, but that is not the information we really want. It is the descent of qualities from men to men, not from youths to youths. The accidents that make or mar a career do not enter into the scope of this difficulty. It resides entirely in the fact that the development does not cease at the time of youth, especially in the higher natures, but that faculties and capabilities which were then latent subsequently unfold and become prominent. Putting aside the effects of serious illness, I do not suppose there is any risk of retrogression in capacity before old age comes on. The mental powers that a youth possesses continue with him as a man, but other faculties and new dispositions may arise and alter the balance of his character. He may cease to be efficient in the way of which he gave promise, and he may perhaps become efficient in unexpected directions.

The correlation between youthful promise and performance in mature life has never been properly investigated. Its measurement presents no greater difficulty, so far as I can foresee, than in other problems which have been successfully attacked. It is one of those alluded to in the beginning of this lecture as bearing on race improvement, and being on its own merits suitable for anthropological inquiry.

Let me add that I think its neglect by the vast army of highly educated persons who are connected with the present huge system of competitive examinations to be gross and unpardonable. Neither schoolmasters, tutors, officials of the universities, nor of the State department of education, have ever to my knowledge taken any serious step to solve this important problem, though the value of the present elaborate system of examinations can not be rightly estimated until it is solved. When the value of the correlation between youthful promise and adult performance shall have been determined, the figures given in the table of descent will have to be reconsidered.

#### AUGMENTATION OF FAVORED STOCK.

The possibility of improving the race of a nation depends on the power of increasing the productivity of the best stock. This is far more important than that of repressing the productivity of the worst. They both raise the average, the latter by reducing the undesirables, the former by increasing those who will become the lights of the nation. It is therefore all important to prove that favor to selected individuals might so increase their productivity as to warrant the expenditure in money and care that would be necessitated. An enthusiasm to improve the race would probably express itself by granting diplomas to a select class of young men and women, by encouraging their intermarriages, by hastening the time of marriage of women of that high class, and by provision for rearing children healthily. The means that might be employed to compass these ends are dowries, especially for those to whom moderate sums are important, assured help in emergencies during the early years of married life, healthy homes, the pressure of public opinion, honors, and above all the introduction of motives of religious or quasi-religious character. Indeed, an enthusiasm to improve the race is so noble in its aim that it might well give rise to the sense of a religious obligation. In other lands there are abundant instances in which religious motives make early marriages a matter of custom and continued celibacy to be regarded as a disgrace, if not a crime. The customs of the Hindoos, also of the Jews, especially in ancient times, bear this out. In all costly civilizations there is a tendency to shrink from marriage on prudential grounds. It would, however, be possible so to alter the conditions of life that the most prudent course for an X-class person should lie exactly opposite to its present direction, for he or she might find that there were advantages and not disadvantages in early marriage, and that the most prudent course was to follow their natural instincts.

We have now to consider the probable gain in the number and worth of adult offspring to these favored couples. First, as regards the effect of reducing the age at marriage. There is unquestionably a tendency among cultured women to delay or even to abstain from marriage; they

dislike the sacrifice of freedom and leisure, of opportunities for study, and of cultured companionship. This has to be reckoned with. I heard of the reply of a lady official of a college for women to a visitor who inquired as to the after life of the students. She answered that one-third profited by it, another third gained little good, and a third were failures. "But what becomes of the failures?" "Oh, they marry."

There appears to be a considerable difference between the earliest age at which it is physiologically desirable that a woman should marry and that at which the ablest, or at least the most cultured, women usually do. Acceleration in the time of marriage, often amounting to seven years, as from 28 or 29 to 21 or 22, under influences such as those mentioned above is by no means improbable. What would be its effect on productivity? It might be expected to act in two ways—

(1) By shortening each generation by an amount roughly proportionate to the diminution in age at which marriage occurs. Suppose the span of each generation to be shortened by one-sixth, so that six take the place of five, and that the productivity of each marriage is unaltered, it follows that one-sixth more children will be brought into the world during the same time, which is, roughly, equivalent to increasing the productivity of an unshortened generation by that amount.

(2) By saving from certain barrenness the earlier part of the child-bearing period of the woman. Authorities differ so much as to the direct gain of fertility due to early marriage that it is dangerous to express an opinion. The large and thriving families that I have known were the offspring of mothers who married very young.

The next influence to be considered is that of healthy homes. These and a simple life certainly conduce to fertility. They also act indirectly by preserving lives that would otherwise fail to reach adult age. It is not necessarily the weakest who perish in this way—for instance, zymotic disease falls indiscriminately on the weak and the strong.

Again, the children would be healthier and therefore more likely in their turn to become parents of a healthy stock. The great danger to high civilizations, and remarkably so to our own, is the exhaustive drain upon the rural districts to supply large towns. Those who come up to the towns may produce large families, but there is much reason to believe that these dwindle away in subsequent generations. In short, the towns sterilize rural vigor.

As one of the reasons for choosing the selected class would be that of hereditary fertility, it follows that the selected class would respond more than other classes to the above influences.

I do not attempt to appraise the strength of the combined six influences just described. If each added one-sixth to the produce the number of offspring would be doubled. This does not seem impossible,

considering the large families of colonists, and of those in many rural districts; but it is a high estimate. Perhaps the fairest approximation may be that these influences would cause the X women to bring into the world an average of one adult son and one adult daughter in addition to what they would otherwise have produced. The table of descent applies to one son or to one daughter per couple; it may now be read as specifying the net gain and showing its distribution. Should this estimate be thought too high, the results may be diminished accordingly.

It is no absurd idea that outside influences should hasten the age of marrying and make it customary for the best to marry the best. A superficial objection is sure to be urged that the fancies of young people are so incalculable and so irresistible that they can not be guided. No doubt they are so in some exceptional cases. I lately heard from a lady who belonged to a county family of position that a great aunt of hers had scandalized her own domestic circle two generations ago by falling in love with the undertaker at her father's funeral and insisting on marrying him. Strange vagaries occur, but considerations of social position and of fortune, with frequent opportunities of intercourse, tell much more in the long run than sudden fancies that want roots. In a community deeply impressed with the desire of encouraging marriages between persons of equally high ability the social pressure directed to produce the desired end would be so great as to insure a notable amount of success.

#### PROFIT AND LOSS.

The problem to be solved now assumes a clear shape. A child of the X class (whatever X signifies) would have been worth so and so at its birth, and one of each of the other grades, respectively, would have been worth so and so; 100 X parentages can be made to produce a net gain of 100 adult sons and 100 adult daughters who will be distributed among the classes according to the standard table of descent. The total value of the prospective produce of the 100 parentages can then be estimated by an actuary, and consequently the sum that it is legitimate to spend in favoring an X parentage. The clear and distinct statement of a problem is often more than halfway toward its solution. There seems no reason why this one should not be solved between limiting values that are not too wide apart to be useful.

#### EXISTING ACTIVITIES.

Leaving aside profitable expenditure from a purely money point of view, the existence should be borne in mind of immense voluntary activities that have nobler aims. The annual voluntary contributions in the British Isles to public charities alone amount, on the lowest computation, to £14,000,000, a sum which Sir H. Burdett asserts on good grounds is by no means the maximum obtainable. (Hospitals and Charities, 1898, p. 85.)

There are other activities long since existing which might well be extended. I will not dwell, as I am tempted to do, on the endowments of scholarships and the like, which aim at finding and educating the fittest youths for the work of the nation; but I will refer to that wholesome practice during all ages of wealthy persons interesting themselves in and befriending poor but promising lads. The number of men who have owed their start in a successful life to help of this kind must have struck every reader of biographies. This relationship of befriender and befriended is hardly to be expressed in English by a simple word that does not connote more than is intended. The word "patron" is odious. Recollecting Dr. Johnson's abhorrence of the patrons of his day, I turned to an early edition of his dictionary in hope of deriving some amusement as well as instruction from his definition of the word, and I was not disappointed. He defines "patron" as "a wretch who supports with insolence and is repaid with flattery." That is totally opposed to what I would advocate, namely, a kindly and honorable relation between a wealthy man who has made his position in the world and a youth who is avowedly his equal in natural gifts, but who has yet to make it. It is one in which each party may well take pride, and I feel sure that if its value were more widely understood it would become commoner than it is.

Many degrees may be imagined that lie between mere befriending and actual adoption, and which would be more or less effective in freeing capable youths from the hindrances of narrow circumstances, in enabling girls to marry early and suitably, and in securing favor to their subsequent offspring. Something in this direction is commonly but half unconsciously done by many great landowners whose employments for man and wife, together with good cottages, are given to exceptionally deserving couples. The advantage of being connected with a great and liberally managed estate being widely appreciated, there are usually more applicants than vacancies, so selection can be exercised. The consequence is that the class of men found upon these properties is markedly superior to those in similar positions elsewhere. It might well become point of honor, and as much an avowed object, for noble families to gather fine specimens of humanity around them as it is to procure and maintain fine breeds of cattle, etc., which are costly, but repay in satisfaction.

There is yet another existing form of princely benevolence which might be so extended as to exercise a large effect on race improvement. I mean the provision to exceptionally promising young couples of healthy and convenient houses at low rentals. A continually renewed settlement of this kind can be easily imagined, free from the taint of patronage and analogous to colleges, with their self-elected fellowships and rooms for residence that shall become an exceedingly desirable residence for a specified time. It would be so in the same way that a good club by its own social advantages attracts desirable candidates.

The tone of the place would be higher than elsewhere on account of the high quality of the inmates, and it would be distinguished by an air of energy, intelligence, health, and self-respect, and by mutual helpfulness.

#### PROSPECTS.

It is pleasant to contrive Utopias, and I have indulged in many, of which a great society is one, publishing intelligence and memoirs, holding yearly elections, administering large funds, establishing personal relations like a missionary society with its missionaries, keeping elaborate registers and discussing them statistically with honest precision. But the first and pressing point is to thoroughly justify any crusade at all in favor of race improvement. More is wanted in the way of unbiased scientific inquiry along the many roads I have hurried over to make every stepping-stone safe and secure, and to make it certain that the game is really worth the candle. All I dare hope to effect by this lecture is to prove that in seeking for the improvement of the race we aim at what is apparently possible to accomplish, and that we are justified in following every path in a resolute and hopeful spirit that seems to lead toward that end. The magnitude of the inquiry is enormous, but its object is one of the highest man can accomplish. The faculties of future generations will necessarily be distributed according to laws of heredity, whose statistical effects are no longer vague, for they are measured and expressed in formulæ. We can not doubt the existence of a great power ready to hand and capable of being directed with vast benefit as soon as we shall have learned to understand and apply it. To no nation is a high human breed more necessary than to our own, for we plant our stock all over the world and lay the foundation of the dispositions and capacities of future millions of the human race.



## THE FIRE WALK CEREMONY IN TAHITI.<sup>a</sup>

---

By S. P. LANGLEY.

---

The very remarkable description of the fire walk collected by Mr. Andrew Lang and others had aroused a curiosity in me to witness the original ceremony, which I have lately been able to gratify in a visit to Tahiti.

Among these notable accounts is one by Colonel Gudgeon, British resident at Raratonga, describing the experiment by a man from Raiatea, and also a like account of the Fiji fire ceremony from Dr. T. M. Hoeken, whose article is also quoted in Mr. Lang's paper on the "Fire Walk," in the Proceedings of the Society for Psychical Research, February, 1900. This extraordinary rite is also described by Mr. Fraser in the Golden Bough, and by others.

I had heard that it was performed in Tahiti in 1897, and several persons there assured me of their having seen it, and one of them of his having walked through the fire himself under the guidance of the priest, Papa-Ita, who is said to be one of the last remnants of a certain order of the priesthood of Raiatea, and who had also performed the rite at the island of Hawaii some time in the present year, of which circumstantial newspaper accounts were given, agreeing in all essential particulars with those in the accounts already cited. According to these, a pit was dug in which large stones were heated red-hot by a fire which had been burning many hours. The upper stones were pushed away just before the ceremony, so as to leave the lower stones to tread upon, and over these, "glowing red-hot" (according to the newspaper accounts), Papa-Ita had walked with naked feet, exciting such enthusiasm that he was treated with great consideration by the whites, and by the natives as a god. I found it commonly believed in Tahiti that anyone who chose to walk after him, European or native, could do so in safety, secure in the magic which he exercises, if his instructions were exactly followed. Here in Tahiti, where he had "walked" four years before, it was generally believed among the natives, and even among the Europeans present who had seen the ceremony, that if anyone turned around to look back he immediately

---

<sup>a</sup>Reprinted from *Nature*, London, August 22, 1901.

was burned, and I was told that all those who followed him through the fire were expected not to turn until they had reached the other side in safety, when he again entered the fire and led them back by the path by which he had come. I was further told by several who had tried it that the heat was not felt upon the feet, and that when shoes were worn the soles were not burned (for those who followed the priest's directions), but it was added by all that much heat was felt about the head.

Such absolutely extraordinary accounts of the performance had been given to me by respectable eyewitnesses and sharers in the trial, confirming those given in Hawaii, and, in the main, the cases cited by Mr. Lang, that I could not doubt that if all these were verified by my own observation, it would mean nothing less to me than a departure from the customary order of nature and something very well worth seeing indeed.

I was glad, therefore, to meet personally the priest, Papa-Ita. He is the finest looking native that I have seen; tall, dignified in bearing, with unusually intelligent features. I learned from him that he would perform the ceremony on Wednesday, July 17, the day before the sailing of our ship. I was ready to provide the cost of the fire, if he could not obtain it otherwise, but this proved to be unnecessary.

Papa-Ita himself spoke no English, and I conversed with him briefly through an interpreter. He said that he walked over the hot stones without danger by virtue of spells which he was able to utter and by the aid of a goddess (or devil as my interpreter had it), who was formerly a native of the islands. The spells, he said, were something which he could teach another. I was told by others that there was a still older priest in the island of Raiatea, whose disciple he was, although he had pupils of his own, and that he could "send his spirit" to Raiatea to secure the permission of his senior priest if necessary.

In answer to my inquiry as to what preparations he was going to make for the rite in the two or three days before it, he said he was going to pass them in prayer.

The place selected for the ceremony fortunately was not far from the ship. I went there at noon and found that a large shallow pit or trench had been dug, about 9 by 21 feet and about 2 feet deep. Lying nearby was a pile containing some cords of rough wood and a pile of rounded water-worn stones, weighing, I should think, from 40 to 80 pounds apiece. They were, perhaps, 200 in number, and all of porous basalt, a feature the importance of which will be seen later. The wood was placed in the trench, the fire was lighted and the stones heaped on it, as I was told, directly after I left, or at about 12 o'clock.

At 4 p. m. I went over again and found the preparations very nearly complete. The fire had been burning for nearly four hours. The outer stones touched the ground only at the edges of the pile, where



FIRE WALK CEREMONY IN TAHITI.





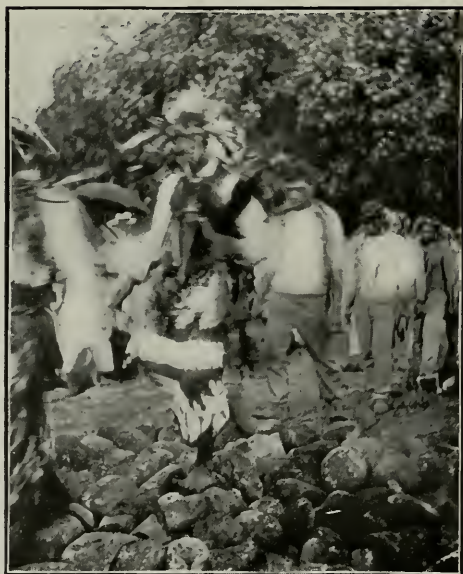

FIRE WALK CEREMONY IN TAHITI.

they did not burn my hand, but as they approached the center the stones were heaped up into a mound three or four layers deep, at which point the lowest layers seen between the upper ones were visibly red-hot. That these latter were, nevertheless, sending out considerable heat there could be no question, though the topmost stones were certainly not red-hot, while those at the bottom were visibly so and were occasionally splitting with loud reports, while the flames from the burned wood near the center of the pile passed up in visible lambent tongues, both circumstances contributing to the effect upon the excited bystanders.

The upper stones, I repeat, even where the topmost were presently removed, did not show any glow to the eye, but were unquestionably very hot and certainly looked unsafe for naked feet. Native feet, however, are not like European ones, and Mr. Richardson, the chief engineer of the ship, mentioned that he had himself seen elsewhere natives standing unconcerned with naked feet on the cover of pipes conveying steam at about 300° F., where no European foot could even lightly rest for a minute. The stones then were hot. The crucial question was, How hot was the upper part of this upper layer on which the feet were to rest an instant in passing? I could think of no ready thermometric method that could give an absolutely trustworthy answer, but I could possibly determine on the spot the thermal equivalent of one of the hottest stones trodden on. (It was subsequently shown that the stone might be much cooler at one part than another.) Most obviously, even this was not an easy thing to do in the circumstances, but I decided to try to get at least a trustworthy approximation. By the aid of Chief Engineer Richardson, who attended with a stoker and one of the quartermasters, kindly detailed at my request by the ship's master, Captain Lawless, I prepared for the rough but conclusive experiment presently described.

It was now nearly forty minutes after 4, when six acolytes (natives), wearing crowns of flowers, wreathed with garlands and bearing poles nearly 15 feet long, ostensibly to be used as levers in toppling over the upper stones, appeared. They were supposed to need such long poles because of the distance at which they must stand on account of the heat radiated from the pile, but I had walked close beside it a moment before and satisfied myself that I could have manipulated the stones with a lever of one-third the length, with some discomfort, but with entire safety. Some of the uppermost stones only were turned over, leaving a superior layer, the long poles being needlessly thrust down between the stones to the bottom, where two of them caught fire at their extremities, adding very much to the impression that the exposed layer of stones was red hot, when in fact they were not, at least to the eye. These long poles and the way they were handled were, then, a part of the ingenious "staging" of the whole spectacle.

Now the most impressive part of the ceremony began. Papa-Ita, tall, dignified, flower-crowned, and dressed with garlands of flowers, appeared with naked feet and with a large bush of "ti" leaves in his hands, and after going partly around the fire each way, uttering what seemed to be commands to it, went back, and, beating the stones nearest him three times with the ti leaves, advanced steadily, but with obviously hurried step, directly over the central ridge of the pile. Two disciples, similarly dressed, followed him, but they had not the courage to do so directly along the heated center. They followed about halfway between the center and the edge, where the stones were manifestly cooler, since I had satisfied myself that they could be touched lightly with the hand. Papa-Ita then turned and led the way back, this time with deliberate confidence, followed on his return by several new disciples, most of them not keeping exactly in the steps of the leader, but obviously seeking cooler places. A third and fourth time Papa-Ita crossed with a larger following, after which many Europeans present walked over the stones without reference to the priest's instructions. The natives were mostly in their bare feet. One wore stockings. No European attempted to walk in bare feet, except in one case—that of a boy, who, I was told, found the stones too hot and immediately stepped back.

The *mise en scène* was certainly noteworthy. The site near the great ocean breaking on the barrier reefs, the excited crowd talking about the "red-hot" stones, the actual sight of the hierophant and his acolytes making the passage along the ridge where the occasional tongues of flame were seen at the center, with all the attendant circumstances, made up a scene in no way lacking in interest. Still, the essential question as to the actual heat of these stones had not yet been answered, and after the fourth passage I secured Papa-Ita's permission to remove from the middle of the pile one stone, which, from its size and position, every foot had rested upon in crossing and which was undoubtedly at least as hot as any one of those trodden on. It was pulled out by my assistants with difficulty, as it proved to be larger than I had expected, it being of ovoid shape, with the lower end in the hottest part of the fire. I had brought over the largest wooden bucket which the ship had and which was half filled with water, expecting that this would cover the stone, but it proved to be hardly enough. The stone caused the water to rise nearly to the top of the bucket, and it was thrown into such violent ebullition that a great deal of it boiled over and escaped weighing. The stone was an exceedingly bad conductor of heat, for it continued to boil the water for about twelve minutes, when, the ebullition being nearly over, it was removed to the ship and the amount of evaporated water measured.

Meanwhile others, as I have said, began to walk over the stones without any reference to the ceremony prescribed by Papa-Ita, and





FIRE WALK CEREMONY IN TAHITI.



three or four persons, whom I personally knew on board the ship, did so in shoes, the soles of which were not burned at all. One of the gentlemen, however, who crossed over with unburned shoes, showed me that the ends of his trousers had been burnt by the flames which leaped up between the stones, and which at all times added so much to the impressiveness of the spectacle; and there was no doubt that anyone who stumbled or got a foot caught between the hot stones might have been badly burned. United States Deputy Consul Ducorran, who was present, remarked to me that he knew that Papa-Ita had failed on a neighboring island, with stones of a marble-like quality, and he offered to test the heat of these basaltic ones by seeing how long he could remain on the hottest part of the pile, and he stood there, in my sight, from eight to ten seconds before he felt the heat through the thin soles of his shoes beginning to be unpleasantly warm.

A gentleman present asked Papa-Ita why he did not give an exhibit that would be convincing by placing his foot, even for a few seconds, between two of the red-hot stones which could be seen glowing at the bottom of the pile, to which Papa-Ita replied with dignity, "My fathers did not tell me to do it that way." I asked him if he would hold one of the smaller, upper hot stones in his hand. He promised to do so, but he did not do it.

The outer barriers were now removed and a crowd of natives pressed in. I, who was taking these notes on the spot, left, after assuring myself that the stones around the edge of the pit were comparatively cold, although the center was no doubt very hot, and those below red-hot. The real question is, I repeat, How hot were those trodden on? and the answer to this I was to try to obtain after measuring the amount of water boiled away.

On returning to the ship this was estimated from the water which was left in the bucket (after allowing for that spilled over) at about 10 pounds. The stone, which it will be remembered was one of the hottest, if not the hottest, in the pile, was found to weigh 65 pounds, and to have evaporated this quantity of water. It was, as I have said, a volcanic stone, and on minuter examination proved to be a vesicular basalt, the most distinctive feature of which was its porosity and non-conductibility, for it was subsequently found that it could have been heated red-hot at one end, while remaining comparatively cool at the top. I brought a piece of it to Washington with me and there determined its specific gravity to be 2.39, its specific heat 0.19, and its conductivity to be so extremely small that one end of a small fragment could be held in the hand while the other was heated indefinitely in the flame of a blowpipe, almost like a stick of sealing wax. This partly defeated the aim of the experiment (to find the temperature of the upper part of the stone), since only the mean temperature was found. This mean temperature of the hottest stone of the upper layer,

as deduced from the above data, was about  $1,200^{\circ}$  F., but the temperature of the surface must have been indefinitely lower. The temperature at which such a stone begins to show a dull red in daylight is, so far as I am aware, not exactly determined, but is approximately  $1,300$  to  $1,400^{\circ}$  F.

To conclude, I could entertain no doubt that I had witnessed substantially the scenes described by the gentlemen cited, and I have reason to believe that I saw a very favorable specimen of a fire walk.

It was a sight well worth seeing. It was a most clever and interesting piece of savage magic, but from the evidence I have just given I am obliged to say (almost regretfully) that it was not a miracle.

## THE LAWS OF NATURE.<sup>a</sup>

---

By S. P. LANGLEY.

---

We say that nature is unchanging, and so perhaps it is, in the eye of some eternal being, but not in ours, for the things that we see from day to day, appear permanent only by comparison to the duration of our own brief life, and our own little experience.

An inhabitant of the land where nature has just passed through such an awful convulsion, with a loss of life greater for so short a time than history has ever recorded, might have said in the morning that nature never changes, because it had never changed in his own little experience; but he would not have said so at that day's close. Now the experience of the entire human race is far briefer relative to nature's duration than that of one of these islanders, who knew the green mountain with its fresh lakes only as a place of quiet rest up to the moment when the gates of hell were opened beneath it.

Nature, then, really changes, and would apparently do so if man were not here; for it is not man's varying thoughts about nature that make her change. But there is something quite different from nature which does change because of man, and which apparently would not change if he were not here. This is what he calls the 'laws of nature.' The assumption that there are such things is due to him, and such 'laws' are known only through his mind, in which alone nature is seen.

It is perhaps an hard saying to most that there are no such things as 'laws of nature': but this is the theme on which I have to speak.

These, then, are the laws of his own mind, or the effects of his own mind, which he projects outside of himself and imagines to be due to some permanent and unalterable cause having an independent existence; and this, not only because his season for observation is but a moment in the passage of nature's eternal year, but because with his pathetic sense of his own weakness, he would gladly stay himself on the word of some unchanging being. It is because this sense of dependence is strangely joined with such self-conceit that when he listens to what he himself says, he calls it the voice of God. From these twin causes, arising both from his inability as a creature of time to observe what is eternal, and

---

<sup>a</sup> A paper read before the Philosophical Society of Washington, May 10, 1902.

again from his own overweening sense of his own capacity, he looks for some immutable being whom he believes to have written man's own ideas in what he calls 'the book of nature.'

I am not questioning the existence of such a being as the 'Author of Nature'; but asking if such a volume as is imputed to him, ever really existed. The very phrase, 'book of nature' is a legacy from moribund mediæval notions of a lawgiver; and it, with the vitality of words which carry to us dying ideas, has lived on to our own time, when we can no longer believe it, although it is still upon our lips, and to convince ourselves of this we need only pause a moment to ask the simple question whether there is any authority who has prepared a clearly written book of statutes, in which we can really read nature's laws.

The question answers itself.

I repeat that I am not denying here the existence of such a being as the imputed author of these laws, but say that, ignorant as we are of what is being done by him, we cannot read his thoughts in our momentary vision of what is forever passing.

"For my thoughts are not your thoughts, neither are your ways my ways, saith the Lord," is a caution which, whether believers or not, would not harm us to consider; and when we say that these 'thoughts' are written in 'the book of nature,' this cannot mean that they are legible there as in a statute book where he who runs may read. If nature is to be compared to a book at all, it is to a book in the hands of infants to whom it conveys little meaning, for such are we; or rather it is like a 'book of celestial hieroglyphs, of which even prophets are happy that they can read here a line and there a line.'

I hope what I am trying to say may not bear the appearance of some metaphysical refinement on common sense. It is common sense that is intended, and the 'laws of nature' that seem to me to be a metaphysical phrase.

To decorate our own guesses at nature's meaning with this name is a presumption due to our own feeble human nature, which we can forgive for demanding something more permanent than itself, but which also leads us to have such an exalted conceit of our own opinions, as to hide from ourselves that it is these very opinions which we call nature's laws.

The history of the past shows that once, most philosophers, even atheists, thus regarded the 'Laws of Nature,' not as their own interpretations of her, but as something external to themselves, as entities partaking the attributes of Deity—entities which they deified in print with capital letters—as we sometimes do still, though these 'Laws' now are shorn of 'the glories of their birth and state' which they once wore, and are not turning out to be 'substantial things.'

But are there not really things (like the fact of gravitation, for

instance) externa. to ourselves, which would exist whether we were here or not, and which are part of the order of nature? Apparently, yes, but part of the *laws* of nature, no!

The phrase even yet exercises a wide influence, though it has seemed to me that a significant change is taking place in the leaders of common opinion with regard to the meaning that the words convey.

I presume that the greater proportion of us here are interested in science. I may indeed assume that we all are; and I want to inquire what lesson for us, as students of nature, there lies in the fact that we are no longer impressed by her 'laws' as were the scientific men of a former generation.

It is convenient to measure the distance we have passed over by the fact that one hundred and fifty years ago, one of the acutest of reasoners. David Hume, published a still celebrated argument against miracles which within my own recollection was held to be so formidable that those who were reluctant to believe in his conclusions were still unable to offer a good refutation. The immense number of attempted refutations and their contradictory character is perhaps the best testimony for this.

Hume defines a miracle as a violation of the 'laws of nature,' and his argument, concisely stated, is that there must 'be a uniform experience against every miraculous event, otherwise the event would not merit that appellation, and as a uniform experience amounts to a proof, there is here a direct and full proof from the nature of the fact against the existence of any miracle.'

Now, while his argument is logically as conclusive as ever, it to-day convinces only those who are anxious to accept its conclusion.

What is the reason for this great change?

We may ask what the laws of nature really are, and pass from what they were thought to be by Hume, to what they are beginning to be understood to be by us, without here inquiring into the intermediate steps which brought the change about.

It seems to me that the argument which was conclusive not merely to the learned, but to the common cultivated thought of Hume's time, has never been expressly refuted when its premises were admitted, (and the generation following him admitted them); and yet this compelling argument, as it once seemed, is gradually losing its force to most minds, not through counter argument, but by an insensible change of opinion in the attitude of the thinking part of our public as compared with his, a change about certain fundamental assumptions on which the argument rested, and from his own views of the universe, to those we are beginning to take.

In the first place, the immensely greater number of things we know in almost every department of science beyond those which were known one hundred and fifty years ago has had an effect which

doubtless could have been anticipated, but yet which we may not have wholly expected. It is, that the more we know, the more we recognize our ignorance, and the more we have a sense of the mystery of the universe and the limitations of our knowledge.

I believe it may be said that if not to Hume, at any rate to the majority of those about him, and to his later contemporaries, there was very much less mystery in the world than we see in it, and if it were then still occasionally said that there were "things in heaven and earth not dreamt of in 'their' philosophy," these words must have struck on the self-complacent minds of his generation, as something to be tolerated as poetic license, rather than as accurate in philosophic meaning. Compared with ours, that whole century was satisfied with itself and its knowledge of the infinite, and content in its happy belief that it knew nearly everything that was really worth knowing. This 'nearly everything' which it thought it knew about the universe, it called the 'laws of nature.'

It was to this belief in the general mind, I think, that the success of Hume's argument was due.

The present generation has begun, if not to be modest or humble, to be somewhat less arrogant in the assumption of its knowledge. We are perhaps beginning to understand, not in a purely poetical sense, but in a very real one, that there may be all around us in heaven and earth things beyond measure, of which 'philosophy' not only knows nothing, but has not dreamed.

As a consequence of this, there is growing to be an unspoken, rather than clearly formulated admission, that we know little of the order of nature, and nothing at all of the 'laws' of nature.

Now if we are, at present at least, disposed to speak of an observed 'order' of nature (not carrying with it the implication of necessity denoted by 'law'), I think we have some reason to say that there is a prescience of a change in common thought about this manner, and that it is owing to this that we are coming to be where we are.

I do not know that there is a less wide belief in the gospel miracles in our day, but if it were so, the decline in the weight given Hume's argument is not due solely to that, for it may surely be said that it was not merely an argument against gospel miracles, but against all the prodigies to be found in history, sacred and profane, where he doubtless had in mind traditions of stones falling out of heaven, cures wrought by psychological agency, and the like, all 'superstitions' to the men of his day, who, if they no longer believed in a deity, were none the less shocked by the culpable existence of such vulgar beliefs in conflict with the deified 'laws of nature,' while such 'superstitions' have in our day become subjects of modest inquiry.

Let me quote from a later writer, whose point of view is singularly different from that of Hume and his contemporaries, and who in



answer to the question, 'What is a miracle?' begins by reminding us that the reply will depend very much upon the intelligence of the being who answers it, or whom the miracle is wrought for.

"To my *horse*, do I not work a miracle every time I open for him an impassable turnpike?"

"But is not a real miracle simply a violation of the laws of nature?" ask several. What are the laws of nature? 'Is it not the deepest law of nature that she be constant?' cries the illuminated class. 'Is not the machine of the universe fixed to move by unalterable rules?'

"I believe that nature, that the universe, which no one whom it so pleases can be prevented from calling a machine, does move by the most unalterable rules. And now I make the old inquiry as to what those same unalterable rules, forming the complete statute book of nature, may possibly be?"

"'They stand written in our works of science,' say you; 'in the accumulated records of man's experience.' Was man with his experience present at the creation, then, to see how it all went on? Have any deepest scientific individuals yet dived down to the foundations of the universe and gauged everything there? Alas, these scientific individuals have been nowhere but where we also are; have seen some handbreadths deeper than we see into the deep that is infinite, without bottom as without shore."

"Philosophy complains that custom has hoodwinked us from the first; that we do everything by custom, even believe by it; that our very axioms, boast as we may, are oftenest simply such beliefs as we have never heard questioned. Innumerable are the illusions of custom, but of all these perhaps the cleverest is her knack of persuading us that the miraculous, by simple repetition, ceases to be miraculous!"

A lesson for us, as people who are most of us interested in science, as to how little its most fixed conclusions may be worth, may perhaps be conveyed in an example. A century and a half ago, when the new science of chemistry won its first triumphs, the fundamental discovery which was to illuminate the whole science, the settled acquisition which it seemed to have brought to us, the thing which was going to last, was 'phlogiston.'

This had everything to recommend it in universal acceptance and in what seemed to the foremost men of the time its absolute certainty.

"If any opinion," says Priestley, "in all the modern doctrine concerning air be well founded, it is certainly this, that nitrous air is highly charged with phlogiston. If I have completely ascertained anything at all relating to air, it is this."

I am trying here to say that all laws of nature are little else than man's hypotheses about nature.

Phlogiston was then to the science of a former age, in this sense a law

of nature, and at least as great a generalization as the kinetic theory of gases is to us; as widely accepted, as firmly believed and as certainly known—but what has become of it now?

Can we tell, then, in advance, by any criterion, what a 'law of nature' is?

With a curious begging of the question some answer, 'Yes, for laws of nature have this distinction, that they have never been disproved.' As if one were to say, Yes, because when they *are* disproved we deny that they are laws of nature!

Those of us who are capable of being instructed or warned by the history of human thought may, then, ask what kind of a guarantee are we to have for any other 'fact' of our new knowledge? May they not—all these 'facts'—be gone like the baseless fabric of this vision, before another hundred years are passed?

The physical sciences seem to have had less change in their theories than the mighty displacements in other branches of natural knowledge, but it is a truism to say that all are changed, and it should be a truism to add that the 'laws of nature' are not to us what they were a hundred years ago.

I repeat that of the 'order' of nature we may possibly know a little; but what are these 'laws' of nature? What celestial act of congress fixed them? In what statute book do we read them? What guarantees them? Our mistake is in believing that there is any such thing, apart from our own fallible judgment, for the thing which the 'laws of nature' most absolutely forbid one generation to believe, if it only actually happens, is accepted as a part of them by the succeeding.

Suppose that a century ago, in the year 1802, certain French Academicians, believing like everyone else then in the 'laws of nature,' were invited, in the light of the best scientific knowledge of the day, to name the most grotesque and outrageous violation of them which the human mind could conceive. I may suppose them to reply, 'if a cartload of black stones were to tumble out of the blue sky above us, before our eyes, in this very France, we should call *that* a violation of the laws of nature, indeed!' Yet the next year, not one, but many, cartloads of black stones did tumble out of the blue sky, not in some far off land, but in France itself.

It is of interest to ask what became of the 'laws of nature' after such a terrible blow. The 'laws of nature' were adjusted, and after being enlarged by a little patching, so as to take in the new fact, were found to be just as good as ever! So it is always; when the miracle *has* happened, then and only then it becomes most clear that it was no miracle at all, and that no 'law of nature' has been broken.

Applying the parable to ourselves then, how shall we deal with new 'facts' which are on trial, things perhaps not wholly demonstrated, yet partly plausible? During the very last generation hypnotism was

such a violation of natural law. Now it is a part of it. What shall we say, again, about telepathy, which seemed so absurd to most of us a dozen years ago? I do not say there is such a thing now, but I would like to take the occasion to express my feeling that Sir William Crookes, as president of the British Association, took the right, as he took the courageous course, in speaking of it in the terms he did. I might cite other things, the objects of ridicule only a few years ago, of debate now, but which have not all found supporters who possess the courage of their convictions.

The lesson for us in dealing with them is not that we should refuse to believe on the one hand, and sneer at everything that is on trial; for this, though a very general and safe procedure, is not one to be recommended to those of us who have some higher ideal than acquiescence with the current belief.

The lesson for us is that we must not consider that anything is absolutely settled or true.

This is not to say that we are to be blown about by every wind of scientific doctrine. It is to be understood as a practical rule of life that we must act with the majority where our faith does not compel us to do otherwise; but it seems to me that we must always keep ready for use somewhere; in the background of our mind, possibly, but somewhere; the perhaps trite notion that we know nothing absolutely or in its essence; and remember that though trite it is always true, and to be kept as a guide at every turning of the scientific road, when we can not tell what is coming next.

How many doctrines of our own day will stand the light of the next century? What will they be saying of our doctrine of evolution *then*? I do not know; but let me repeat what I have said elsewhere, that the truths of the scientific church are not dogmas, but something put forward as provisional only, and which her most faithful children are welcome to disprove if they can. I believe that science as a whole is advancing with hitherto unknown rapidity, but that the evidence of this advance is not in reasoning, but in the observation that our doctrine is proving itself, by the fact that through its aid Nature obeys us more and more, as I certainly believe it does.

Never let us forget, however, that man, being the servant and interpreter of nature, as Bacon says, can do and understand so much, and so much only, as he has *observed* of the course of nature, and that beyond this he neither knows anything nor can do anything. No walk along 'the high priori road' will take him where he wants to go, and no 'law of nature' will certainly help him.

But these 'laws', having authority only as far as they are settled by evidence and by observation alone, it may be a just inquiry as to what constitutes observation and, above all, who judges the evidence.

If the kinetic theory of gases, for instance, is a matter of inference rather than of observation, are we sure that we have a better guarantee for it than a previous century had for phlogiston? Our good opinion of ourselves, as compared with our scientific fathers, makes us think we have. Certainly I think myself that we have; and yet, remember, it is the same human nature which judged that evidence then, that judges this evidence now, and remember that however rapidly science changes, human nature remains very much the same, and always has a good conceit of itself.

While we are venturing to utter truisms, I repeat, let us take once more this one, home to ourselves, that there is a great deal of this 'human nature' even in the best type of the scientific man, and that we of this twentieth century share it, with our predecessors, on whom we look pityingly, as our successors will look on us.

Let us repeat, and repeat once more, that though nature be external to ourselves, the so-called 'laws of nature' are from within—laws of our own minds—and a simple product of our human nature. Let us agree that the scientific imagination can suggest questions to put to nature, but not her answers. Let us read Bacon again, and agree with him that we understand only what we have observed. Finally let us add that we never understand even that, in the fullness of its meaning, for remember that of all the so-called laws of nature, the most constantly observed and the most intimately and personally known to us are those of life and death—and how much do we know about the meaning of *them*?





CHILDREN'S ROOM

A. ROSE & CO. LITHOGRAPHERS, BALTIMORE.

## THE CHILDREN'S ROOM IN THE SMITHSONIAN INSTITUTION.<sup>a</sup>

BY ALBERT BIGELOW PAINE.

[Adapted by the author, from his article in *St. Nicholas* for September, 1901.]

It was Mr. S. P. Langley, the Secretary of the Smithsonian Institution, who had personally ordered and arranged several successive attempts to make exhibitions for the especial benefit of children, little children, who did not care for long, hard names, and who could not see objects on high shelves.

An attempt which he wished to be final was made, but he could not personally oversee the work of preparation, and when he did look into it he was dissatisfied. There were a good many things in the cases that, as one of the children, he did not care for. Clearly something must be done.

Dr. Langley, as Secretary, appointed himself as honorary curator of the children's exhibit, with instructions to see that a room was reserved and properly prepared for little children who wished only to look and wonder, and find out such things as little people most want to know. The appointment was accepted by him in the following terms:

The Secretary of the Smithsonian Institution has been pleased to confer upon me the honorable but arduous duties of the care of the Children's Room. He has at his service so many men learned in natural history that I do not know why he has chosen me, who know so little about it, unless perhaps it is because these gentlemen may possibly not be also learned in the ways of children, for whom this little room is meant.

It has been my purpose to deserve his confidence, and to carry out what I believe to be his intention, by identifying myself with the interests of my young clients. Speaking, therefore, in their behalf, and as one of them, I should say that we never have a fair chance in museums. We can not see the things on the top shelves which only grown-up people are tall enough to look into, and most of the things we can see and would like to know about have Latin words on them which we cannot understand; some things we do not care for at all, and other things which look entertaining have nothing on them to tell us what they are about.

<sup>a</sup> Reprinted by permission of The Century Company.

In that great work, our very highest authority on the subject (need we say that "The Swiss Family Robinson" is meant?), we have always taken unmixed delight, although some people say that so many kinds of interesting beasts could never really have been in one island. If there are any errors there, though, we do not love it for them, but for its good qualities, and the first of these is that it interests us all through. We think there is nothing in the world more entertaining than birds, animals, and live things; and next to these is our interest in the same things, even though they are not alive; and next to this is to read about them. All of us care about them, and some of us hope to care about them all our lives long. We are not very much interested in the Latin names, and however much they may mean to grown-up people, we do not want to have our entertainment spoiled by its being made a lesson.

Now, I entirely agree with my small friends so far, but I will add something that they only dimly understand and that some of their instructors do not understand at all. It is that to interest the young minds in such things is to lay the foundation for more serious study in after life. There are spots on the sun, and even the "Swiss Family Robinson" is not quite perfect as an authority in natural history; but the "child is father to the man," and many a young naturalist would never have been a student of nature at all if he had not owed his first impulse to some such work as that, or to the sight of things, like those in the Children's Room, arranged for the same minds that delight in the book.

Some great philosopher has said that "Knowledge begins in wonder," and there is a great deal in the saying. If I may speak of myself, I am sure I remember how the whole studies of my life have been colored by one or two strong impressions received in childhood. The lying down, as a child, in a new England pasture and looking at the mysterious soaring of a hen hawk far above in the sky has led me to give many years of mature life to the study of the subject of traveling in air; and puzzling about the way the hotbed I used to see on the farm kept the early vegetables warm under its glass roof has led to many years of study in after life on the way that that great hotbed, the earth, is kept warm by its atmosphere; and so on with other things.

I wish that all children might, as they grow older, learn the sense of the poet who has said:

Who is the happy warrior? Who is he  
That every man in arms should wish to be?  
It is the generous spirit who, when brought  
Among the tasks of real life, hath wrought  
Upon the plan that pleased his boyish thought.

Doctor Langley has thus told us of his appointment as curator of the children's room, but he has not told us of what long years of preparation have been crystallized into this apparently simple task, what patient, thoughtful work in every department and detail, with the interest and the entertainment of the child always in view.

After accepting this somewhat arduous and wholly portionless task, he undertook to do his best to have such a place provided and install in it only such things as his friends, the other children, would like.





HUMMING BIRDS

A. HOEN & CO. LITHOGRAPHERS BALTIMORE





A. H. S. & C. CO. BALTIMORE

TOUCAN







A. MENZ & CO. LINCOLN SQUARE BALTIMORE

MANDARIN DUCK

It was at once determined that the room to be assigned to this purpose must be a small one; a large room would mean a large collection, and this in return would result in confused and hasty examination and the discouragement of the child. It must be a cozy, pleasant room, with plenty of light and pretty things, as well as a collection of specimens, not many in number, but each object chosen just to give the child pleasure. If the child received instruction, too, well and good; but first of all he must be attracted and pleased, and made to wonder, for in wonder lie the beginnings of knowledge.

This was the Secretary and Honorary Curator's idea; and with the gladly and heartily given help of ornithologist, zoölogist, mineralogist, of the whole staff of the Institution in fact, his plans for a children's room in the Smithsonian have been, and still are being, carried to successful realization.

Located just across from the main entrance, it is a sunny little spot, with doors and windows opening to clambering vines, grass plots, and happy trees, where in summer are birds that build and sing. It was June when I saw it, and perhaps this is the choicest time to go; but even dark days and cold will not keep us from feeling the cheer of riotous vines and singing birds.

For they are within as well as out. The ceiling is painted to represent a vine-clad arbor, with sky spaces through which birds of gayest plumage seem to look down on friends and relatives below.

Indeed, a number of living relatives are just below, where four gilt cages of song supply a never-ending chorus of nations, the little singers having been chosen from the many far and near corners of the whole earth.

Our own redbird, or cardinal grosbeak, is there, as well as the South American cardinal of Brazil; bullfinches and goldfinches from Europe; the Japanese robin, who is really not Japanese and not a robin, but a very nice bird from India; some weaver-birds from Africa; some Javan sparrows from the East Indies, and some Australian grass-parakeets, such as are trained and used by street seers for telling fortunes. They are a happy congress, and it grieves me to relate how two little cages contain but one bird each, a certain canary and a hybrid goldfinch, whose names, for their parents' sake, I will not give, but who proved to be so wicked and quarrelsome, and made the others all so very unhappy, that they must now live each to himself, alone, and yet near enough to see the happiness of the others, who all day long play, and visit, and sing in undisturbed harmony.

Below the singing birds are the aquariums, a salt-water glass tank, and a most perfect fresh-water aquarium, so simply and carefully arranged that even the very little child may look and love and wonder from every side, where pretty bright fishes and baby turtles wave and dart and paddle amid feathery green and over the pebbly beds.

The aquariums and the gilt cages are the center of the room, and, because of the happy varicolored life they contain, must always remain the true center of attraction to little folks—the point to which they will turn and return, again and yet again, from the fascinating and even more marvelous, but silent, wonders in the cases along the walls.

The cases themselves are quite low, even the top shelves being within reach of younger eyes. Arranged above them are a number of prints and water-color paintings, in which some of the furred and feathered creatures below are shown in action; and this idea is to be carried still further in the panels of the wall, for these in course of time are to be filled with interesting and lifelike pictures by artists who paint lovingly their friends of the wood and field.

But it is within the cases that the child will find the true soul and purpose of the Children's Room. Often he may turn to the singing birds and the darting fish for refreshment, but with the wonders along the wall he will linger, and the memory of them will cling and blend, and so become a part in his life that shall not perish or grow dim.

In speaking of the young observer in this article as "he," I do not wish it to be understood that the room is not fully as interesting and valuable to little girls. I am only, for the most part, picturing a boy, such as "the one I knew best," who, a good many years ago, was obliged to learn a good many things vaguely and at long range. I find that he is still hungry to know some of the things he never could find out then, and I am fancying what he might have felt and done if in that far-away time he had found himself, all at once, among these precious cases.

They are arranged as a child would wish them, and he will begin, perhaps, with those on the left as he enters—the cases of the birds. At the first of these he will linger. Within are the "Largest and smallest birds of prey." He will look at the great condor of the Andes, and the bald eagle, and then at the tiny sparrow hawk; and he will wonder why these are so big and that so little, and if the bald eagle could whip the condor in a fair fight. He thinks it likely, because the condor has blunt claws—so blunt, the card says, that he can not carry off the big animals he sometimes kills. The condor is bigger than the bald eagle, but he is not so good looking, and the child does not like him. He likes much better the largest owl, the great eagle owl, who lives in the vast, trackless woods of northern Europe and Asia—a monarch of the far, dim stillness; and if the child is a little girl, she adores the smallest of his race, the tiny elf owl, who might well be a real sprite to dart from the leafy, dewy tangle of evening.

The small observer passes on. "Some Curious Birds" come next, and he must see them, even if he has to come back to the bald eagle





A FROM B. LITTON, CALIFORNIA, BALTIMORE

TANAGER







PRINCE ALBERT'S BIRD OF PARADISE

and the condor, and the different-sized owls, by and by. He wonders and laughs, too, at the curious birds. Truly they are a funny lot. Some of them have fans that fold. Others have veils, aprons, crowns, lappets, armor, and what not. The toucan has such an absurd big bill. The black skimmer's flat bill is set the wrong way. A queer paradise bird has one tail where it should be, besides two very long tails that are half saw and half feather, and that start from behind his ears. Then there is a row of little bat-parrakeets that sleep with their heads hanging down. The child wonders why the blood doesn't run to their heads, and how the umbrella bird can see through the thick tangle of his head covering. Almost all the curious birds have funny attachments, something they don't seem to need—all except the poor apteryx from Australia, who has much less than he should have, because he is left over from some undeveloped age, with paltry, half-formed feathers, and no wings at all. The child pities the apteryx—he looks so timid and sorry—and the card tells us he is often killed by dogs, because he can not fly. He is so different from his fine neighbor, the laughing jackass, whose expression is always humorous, and who seems always about to make merry with the whole queer lot.

Just below these is a shelf of "Bright-colored Birds." If the child is a little girl, here she will linger long. The vividly blue cotinga of British Guiana, the beautiful—the most beautiful—parrakeet, the rose cockatoo of Australia, the elegant minivet, and the crimson-winged lory—these she will love with all her inborn adoration of beautiful adornment, and yearn for them in her dreams. I hope she will not want the wings for her hat, but I should hardly blame her if she did, for their beauty is the splendid and lavish kind that nature gives to flowers, and that nature, and nature only, has ever learned how to bestow. To me the mandarin duck seems the gem of this collection—a fowl whose dress is so Chinese in its cut and coloring that one wonders whether he has really imitated the mandarins or they him.

And now come the "Common Birds of Europe" and the "Familiar Birds of the United States." The child has yearned long to see the raven, the magpie, the starling, and the jackdaw of his storybooks, and the English lark and robin from which, long ago, our native meadow-singer and redbreast were named by a people heartsick and homesick for their own far lands. The curlew, the rook, and the lapwing, these, too, are among the European birds, while the phoebe, the bittern, the kingfisher, the bobwhite, and the bobolink are among their American cousins, as well as our own lark and robin, not forgetting the beautiful but cruel blue jay, and the tiny ruby-throated humming bird, so familiar to us all.

The child is proud of his own birds. Perhaps he wishes they were more gaudily colored, and wonders why parrakeets and pink cockatoos do not dwell in his own woods and fields. Still, there is the gay car-

dinal and the pretty bluebird, whose color is like a bit of sky. The child is glad to see that of the poetical quotations, and a number of these are in various cases, there is a special one for the bluebird—the pretty lines by Eben Rexford:

Hear it again above us,  
And see what a flutter of wings;  
The bluebird knows it is April,  
And soars to the sun and sings.

In the case next to this are "Birds with Curious Nests and Eggs." The heart of the small observer finds great joy in this case. The smallest and largest eggs in the world, those of the humming bird and the giant ostrich, or *Aepyornis*, of Madagascar, who no longer lives, but whose eggs, that were more than a foot in length, are still to be discovered.

The child ponders long over these eggs. The card tells him that the *Aepyornis* and the great roc of his storybooks are believed to be the same bird. He wonders how many times larger the big egg is than the little one. If he asks, as I did, he will be told that it is about thirty thousand times as big, and he will picture to himself the great bird, as tall as a tree, sweeping over the sands with furlong strides.

Within this case, too, are other curious eggs, large and small, including those of the eagle, the ostrich, and the great moa of New Zealand, while among the curious nests the child sees the homes of the hang-bird, the weaver bird, and the tailor bird. Much and long he wonders how these clever house builders wound in and out the threads and fibers of their marvelously built homes. But just below there is a nest with eggs. It is not a curious nest, but built in a curious place—in a skull, in fact, and it is the nest of the tiny house wren.

And now beyond these come the "water birds"—the great albatross, which perhaps the child remembers as having been shot by the Ancient Mariner; the king penguin of the far white south, the white egret, hunted for his rare plumage, and the scarlet ibis, whose flaming feathers make him a shining mark for death.

The child is sorry that these rare birds are killed for their wings and plumes. If a little girl, perhaps she resolves never to wear them. She remembers that birds have little folks, too, and she wonders what becomes of them when the parent bird is shot down and can never return to them with food.

But at the next case these things are forgotten. At the top instead of a picture there is a lyre bird, with his tall magnificent tail, and a mounted beaver. The child remembers that Hiawatha was taught

How the beavers built their lodges.

He thinks this must be one of the same beavers and wonders if it is full grown and how it is he can use his tail to build with.



LARGEST AND SMALLEST BIRDS OF PREY.

Harpy eagle, 38 inches long; little hawk, 6½ inches long.







THE CRESTED FLYCATCHER.—This bird ornaments its nest with the cast-off skin of a snake, the purpose being apparently to frighten off intruders.

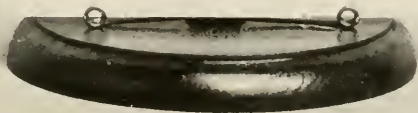

THE CRESTED FLYCATCHER.





EUROPEAN ROBIN.

*Erithacus rubecula* (LINN.).

Europe.

ROBIN REDBREAST.—One of the best beloved birds of England. This is the bird of the ballad of the *Babes in the Wood*:

“No burial this pretty pair  
From any man receives,  
Till robin redbreast, piously,  
Did cover them with leaves.”

SPECIMEN OF TECHNICAL LABEL AND LABEL WITH POPULAR INFORMATION.

Above the beaver is a fine spray of peacock plumes, and in the case beneath him a kite carrying a snake, some bower birds with their play-house, and some ptarmigans in both winter and summer dress. The child rejoices in the bower birds. He has a little book with a picture of them, but here they are at home with their playthings. There are several of them, and he wonders if they have invited in friends to see and play with the pretty shells and colored glass they have found.

But the ptarmigans he can hardly believe real, their winter dress is so snow-white, while in their summer plumage they are so brown and mottled, like a pheasant. Still, the cards tell him they are the same, and though he wonders much, yet he must believe.

Then he passes on to "How Creatures Hide," the Children's Room name—and a very happy one—for protective mimicry. Here the leaf insects, that are so like the leaves about them as to make the observer almost "give it up" before he discovers that some of the leaves open and form wings, while beneath others there lie curious creatures so near in shape and color to their hiding place that only the sharpest eyes will find them. Nests there are, too, that might well be a part of the limb that holds them; and beneath, in a box of sand and pebbles, are some terns' eggs and young. And the young terns are so like the eggs, and the eggs so like the pebbles, that even after he sees them he must take a second and a third look to make sure.

And now there is a case of "Pretty Shells" and "Strange Insects." The wonderful coloring of the sea has found its way into the shells, while the hues of the air have tinted the wings of butterflies more rare than any the child has ever chased or captured. The child looks longingly at this collection. There are some things here he would like to have. But the centipede, and the tarantula with the poor little bird it has captured and poisoned to death, make him shudder. He is close enough to these, and he is glad they are dead. He wonders why they must ever live at all.

Corals and sponges have their separate case, and the specimens range from the great brain coral and Neptune's cup to the delicate and beautiful Venus's flower basket, a superb white sponge from the Philippine Islands.

And now the child has reached the last case in the room. It contains "Minerals and Fossils," and here are some things that make him wonder indeed. On a block lies a piece of flexible sandstone that bends by its own weight. Near by is a true model of the largest lump of gold ever found in the world, and of the largest diamond ever cut. His eyes dwell long on these things. He wonders about their value, and if the people who found them were very poor, and how happy they must have been with that great lump of gold and with that splendid diamond. Some day he will go out into the wild mountains and find gold and diamonds too. He wonders just where he ought to look

for them. Then, all at once, his eye catches some woven and spun asbestos, that nobody can burn up, no matter how hot the fire is, and he thinks he would like a suit of this material, and so become a fireman, and live happy ever after. And now the child has finished the circuit of the room. He turns once more to the song birds and darting fish, and before he goes he must have one more look at the cases. The owls, the swallows, the night hawk, and the whippoorwill—such things as these he has been glad to see at close range. Heretofore they have been to him but as darting shadows, or weird voices from the dusk of evening. He has seen swallows circling about the chimney at nightfall, diving in one by one, and he has heard them cuddling cosily together at bedtime. Now for the first time he knows just how they look, just how they build their nests, and how they cling to the rough brick with feet that are set too far back on their bodies for them ever to perch on a limb without toppling over.

And the child goes home at last, glad, and with knowledge, and the love of knowledge, in his heart. He is happy, and, because his wonder has been aroused, he has learned. Unless he is a very small child, he has been able to read the large, clear type of the simply worded labels, on which, with one exception, there are no more Latin names. The exception is made in favor of a very small humming bird, who bears bravely his technical title, *Rhamphomicron microrhynchum*, left by the honorary curator as the best explanation of why he has not retained the others. Of all the rest the common names only are given; and where no common name exists, a literal translation of the Latin name is made. All the labels the child has been able to read, and he is not wearied, and he has not been puzzled or confused.

Perhaps the child who has passed an hour or two in this room full of interest and pleasure does not know or care to whom his happiness and his thanks are due. It does not matter. If he only cares for the thing itself, cares enough to come again, and perhaps bring his parents, that they too may look and learn with young eyes (and if he is the child most of us have known best, he will do this), the Secretary and Honorary Curator will be amply repaid.

Doctor Langley has strenuously opposed all appreciative mention of himself in this paper, and it is only through my most urgent insistence that I have been permitted to let any portion of the meager justice of the original article escape the sacrifice demanded by the modest Curator.

I note with pleasure the addition of the beautiful color plates of the butterflies, insects, humming birds, Mandarin duck, etc., which deserve mention not only because of the fascinating subjects which they portray, but because they represent the very latest developments in the art of color reproduction. My only regret is that these handsome illustrations could not be presented to the readers of *St. Nicholas*, in which the original article appeared.



BUTTERFLIES

ARGENT CO. WASHINGTON, D. C.







HOW A BUTTERFLY HIDES

ANCHER BULLOCK, BALTIMORE

OBSERVE THE TWO ON TWIG WITH FOLDED WINGS.





PTARMIGAN IN WINTER PLUMAGE.



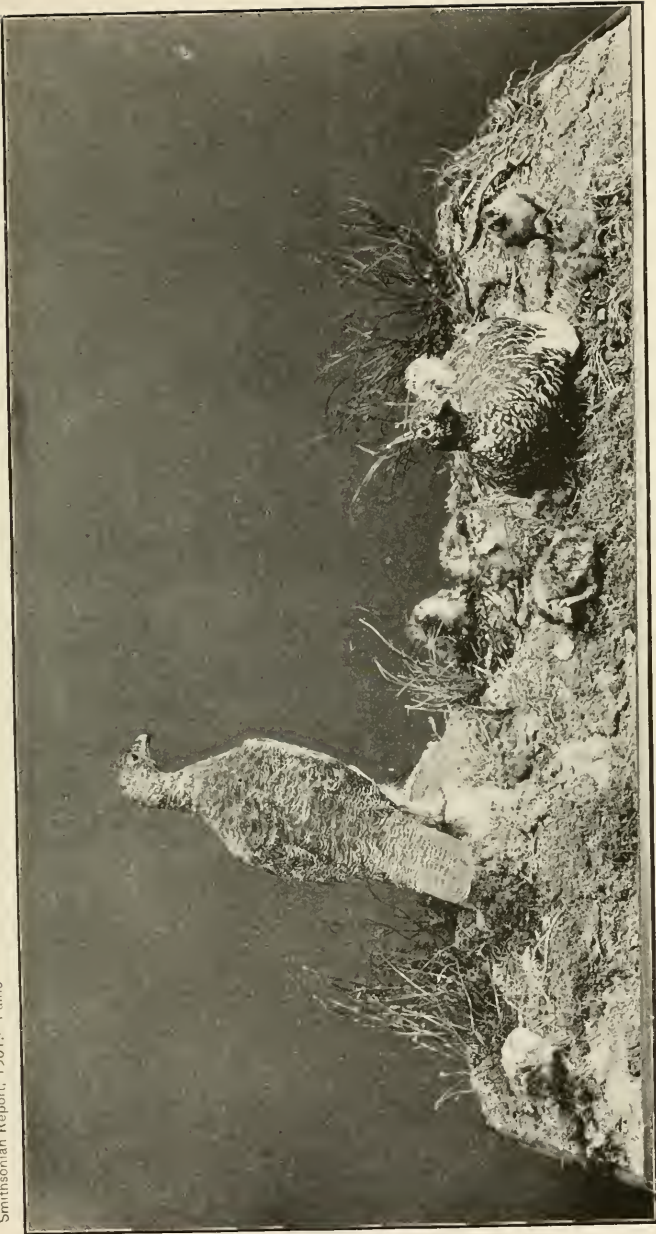

PTARMIGAN IN SUMMER PLUMAGE.



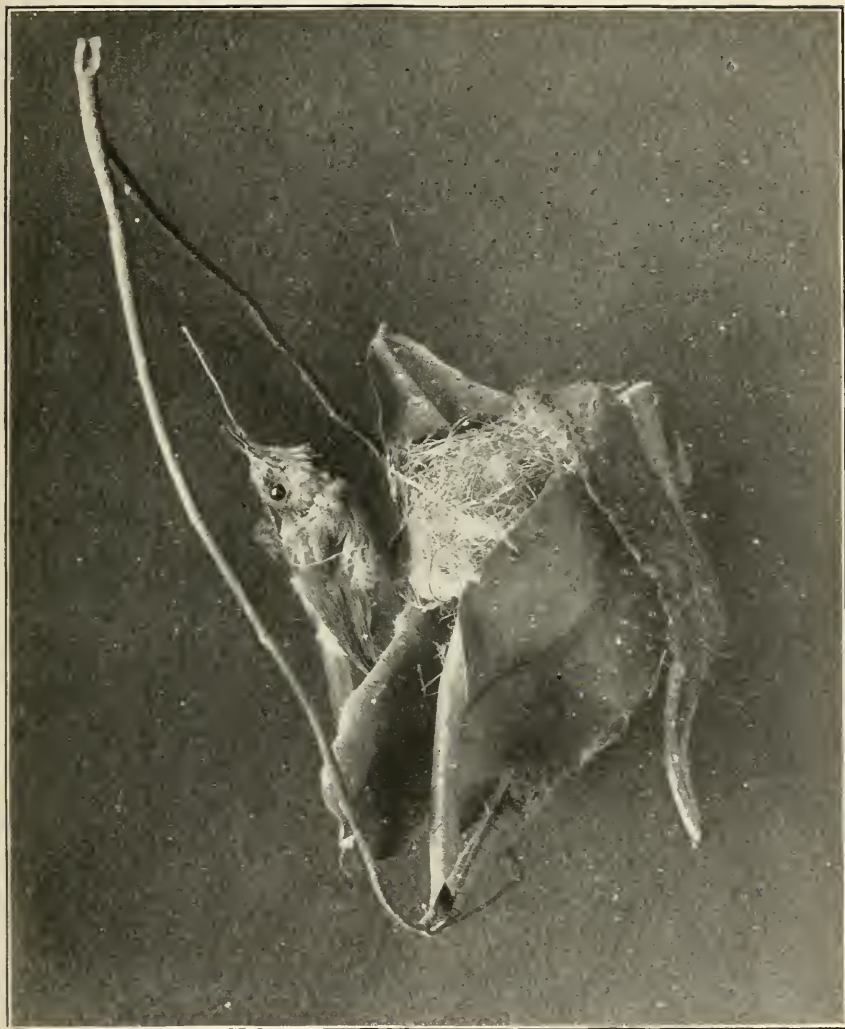

THE TAILOR BIRD.

This bird sews two or three leaves together to form the walls of its nest. It lives in the East Indies.





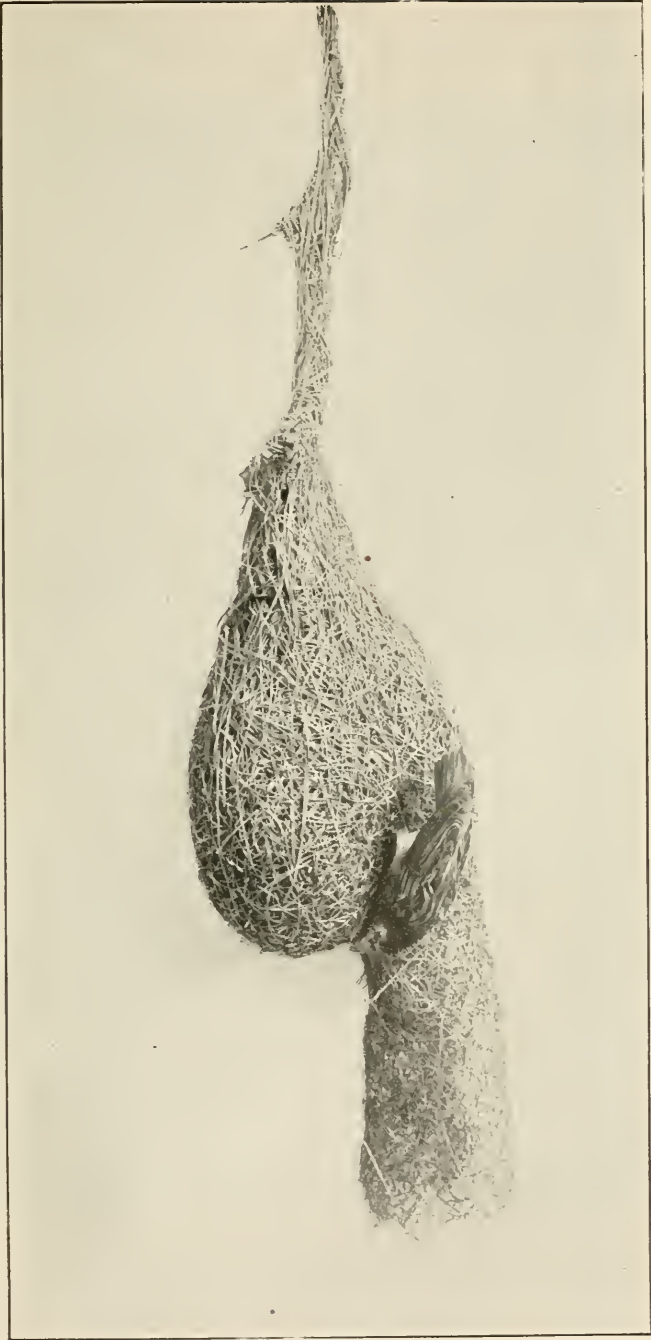

A HANGING NEST.





THE NIGHT HAWK AND ITS EGGS AND YOUNG.

The night hawk makes no nest, but lays its eggs on the bare ground, where eggs and young birds are both safely hidden by resemblance in color to dead leaves and driftwood.



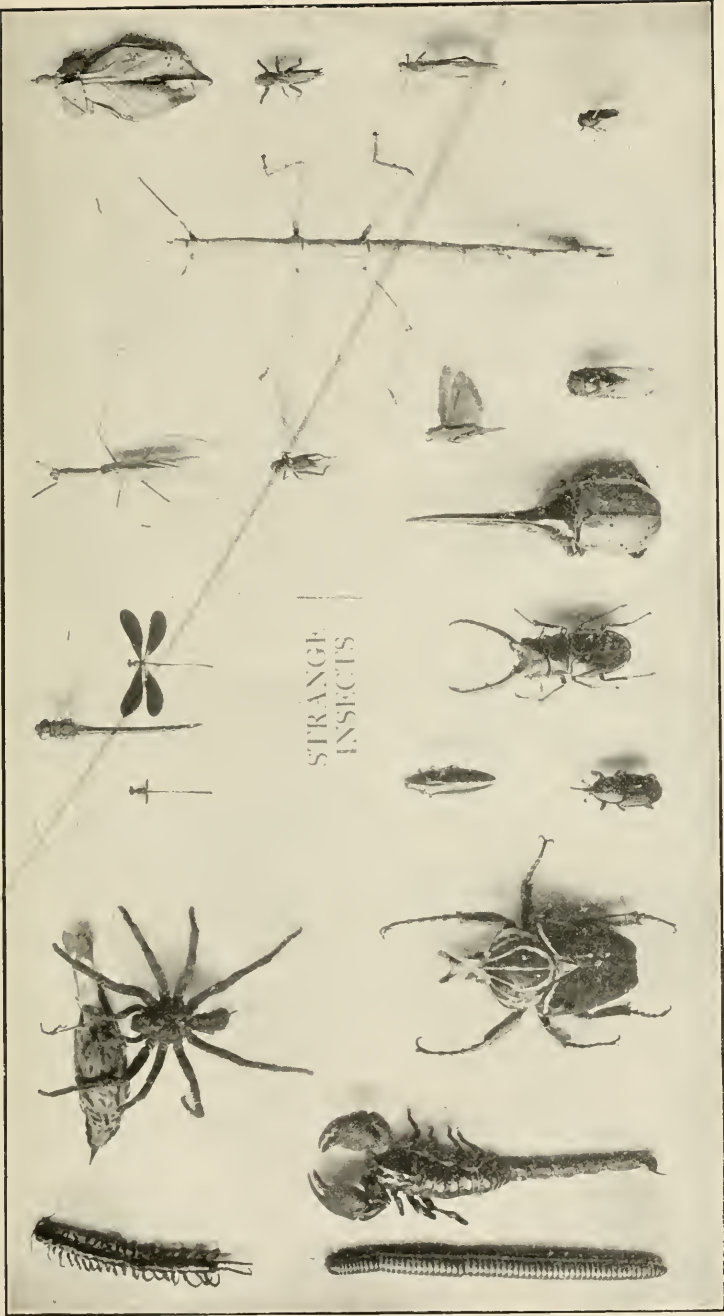

SPIDERS, SCORPIONS, THOUSAND LEGS, AND WALKING STICKS.





ROYAL WALNUT MOTH, ATLAS MOTH, OWL BUTTERFLY, AND OTHER STRANGE INSECTS.







THE SMALLEST EGG AND THE BIGGEST.  
Humming bird egg, .51 inch long; apyormis egg, 1.34 inches long.



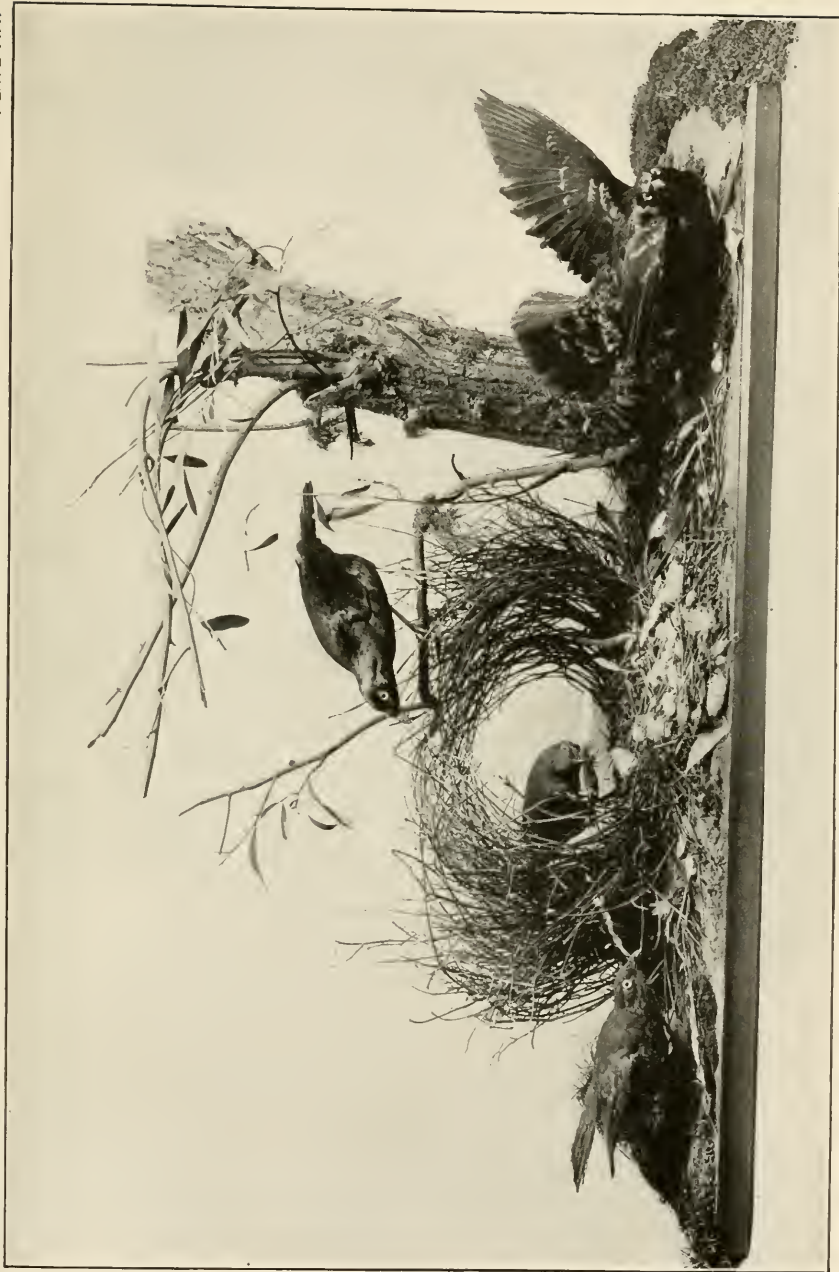

THE BOWER BIRD GROUP.



## SALT AND ITS PHYSIOLOGICAL USES.<sup>a</sup>

---

By M. A. DASTRE.

---

Salt is a universal commodity. It seems to have been used almost without exception in all places, times, and civilizations. To-day it seasons the wretched meal of the Soudan negro and the carefully selected repast of a European table. We find the same predilection for its use as far back in history as we can go. The Jews offered it to Jehovah with the first fruits of the harvest and the fruits of the earth; Homer calls it divine and chronicles its use in the repasts of his heroes; Tacitus tells of furious wars between the Germanic tribes for the possession of salt springs near their territories.

Indeed, men have recoiled before no hardship, no sacrifice, and no danger to procure this precious substance. They have sought to obtain it by war, by fraud, by the fatigue of long journeys. Some very primitive peoples have been remarkably ingenious in methods of procuring it for their own use; for example, the aborigines of the Sunda Islands have invented rude chemical processes for extracting it from the mud about their mangrove trees. Mungo Park saw the inhabitants of the coast of Sierra Leone give all that they possessed, even their wives and children, to obtain it. It is, in fact, an object of so general consumption, so necessary to man, that it affords an assured medium of exchange, and that is what is meant when we say that salt has been used and is still used for money. This is true for the different countries in central Africa. It was the same in ancient times, and, since the Roman soldier received in his ration salt as well as oil, meat, and cheese, his compensation took the name of *salary*, a name extended later to all stipulated wage for material work.

The need, the hunger for salt is not confined to man. Many animals seek this substance with avidity. Buffon wrote: "Nothing pleases the appetite of sheep more than salt." Barrall, Boussingault, and Desaive have informed us that cattle may suffer cruelly from a

---

<sup>a</sup>Translated and condensed from the *Revue des Deux Mondes* for 1901, Vol. I, pp. 197-227.

lack of salt, and that, on the other hand, they thrive when it is added to their ration.<sup>a</sup>

Reindeer and red and roe deer love to lick the surface of brackish puddles and saline efflorescences. In all climates, in all latitudes, wild ruminants and other hoofed animals resort to salt licks, a circumstance of which hunters take advantage, choosing their shooting covers either where salt naturally effloresces or where they themselves have scattered it.

A predilection so general and an appetite so imperative can not be considered as mere accidents. They doubtless correspond to a natural need of the system. Modern physiology has attempted to discover the reason for their existence which must be profoundly based in the animal organization. It has asked why, among the mineral substances that form a part of our food, some of which enter much more extensively into the constitution of our tissues, common salt should be the only one that man artificially adds to his natural aliment. The salts of lime and the phosphate of soda, for example, which compose so large a part of the skeleton or of the liquids of our economy, are not used at all in cookery. If we sometimes use them in an isolated state it is merely as medicines. What is the reason for this instinctive and peculiar employment of common salt over and above the quantity naturally contained in foods? This brings up the more general question of the part which salt plays when once introduced into the organism; of the physiological phenomena in which it participates; in a word, of the evolution which it undergoes. \* \* \*

## I.

Salt was first used as an aliment at the time of transition from the pastoral and nomadic stage to sedentary and agricultural life. The Indo-European languages have no common word to designate salt, nor have they any for the greater number of the objects that relate to agriculture. But, on the other hand, they have common roots for all words relating to pastoral occupations. We may see in this an indication that the primitive peoples from which our modern races sprang were separated before they abandoned a pastoral life. They did not learn the art of agriculture until later, and with it they learned the use of salt.

There are populations, ethnic groups, and castes that have never adopted it. The Egyptian priests did not salt their food. Plutarch was astonished at this strange disdain. Sallust says that the Numidians did not care for salt: *Neque salem, neque alia irritamenta gulæ quærebant.* And in the same way we see around us, side by side with

<sup>a</sup> In practical agriculture it is generally admitted that there should be given to each sheep about 2 to 5 grams of salt per day, 30 to 50 grams to a horse, 60 to 100 grams to an ox. In England and in Germany stock raisers much exceed these amounts.

animals of the farm that are very fond of it the dog and the cat that do not care for it at all.

These exceptions have been for a long time considered as inexplicable. It could not be understood how the need for salt could, in certain cases, be as imperative as true physiological needs, such as hunger and thirst, while in others it seemed entirely foreign to the organism. A learned physiologist, M. Bunge, of Basel, has thrown some light upon this obscure question. After an extensive investigation, ethnographic, historic, and geographic, he has drawn the primary conclusion that the use of salt is connected with the kind of diet. Salt is a necessary complement to a vegetarian regimen. Among animals it is the herbivora that seek it with avidity. Carnivora are indifferent to it or even regard it with disgust. Among men the appetite for this seasoning exists especially in those whose food consists of leguminous vegetables and cereals; that is to say, among agricultural populations or at least among those who live on a mixed diet. On the contrary, those who do not care for it are the pastoral tribes that live upon milk and meat that they derive from their flocks and herds, hunting tribes that subsist upon the products of the chase, and fishing populations who, although they dwell by the sea or at the mouths of rivers, where they can get plenty of salt, yet do not use it. Now, if this is really the case, we may at least consider that the correlation between these two phenomena, the development of agriculture and sedentary life on the one hand and the use of salt with the food on the other, is worthy of investigation.

All the nomadic tribes of the north of Russia and Siberia abstain from salting their food. They can readily obtain salt; for deposits, efflorescences, and salt lakes abound in those regions; still these peoples, who live by the chase and by fishing, have a decided aversion for this condiment. An explorer who lived a long time with the Kamchadales and Tunguses, the well-known mineralogist, C. von Ditmar, amused himself by inducing them to taste the salted food which he himself used and by noting the expressions and grimaces of dislike which this simple seasoning caused. This was not, however, because these people had an excessive delicacy of taste. They habitually fed upon an unnamable mixture made of fish massed in enormous silos where they putrefied at leisure awaiting the time when they should be eaten. The Russian Government desired to change these too disgusting and unhealthy food habits. It taught these peoples the art of salting fish so as to preserve them from putrefaction, establishing for this purpose curing stations near their encampments and furnishing them with salt at nominal price. Vain efforts! These docile peoples obeyed. They salted the fish, but they ate them not.

Similar examples of indifference or antipathy to this apparently necessary seasoning are found in other latitudes. The Kirghizes of

Turkestan, who live upon milk and meat in their salt steppes, do not use salt at all. The Bedouins of Arabia, according to Wrede, find the use of salt ridiculous, and the Numidians, whom Sallust describes as disdaining the use of salt, fed, according to his testimony, upon milk and meat—*lacte et carne ferina*.

Africa furnishes still other examples quite as demonstrative. The Scotchman, Mungo Park, who a century ago explored the region now called the great bend of the Niger, was struck with the eagerness for salt shown by the negro agricultural populations. This was brought to them with difficulty and sold at a very high price by caravans that obtained it from Mauritania, from the sebkha of Ijil, halfway between Senegal and Morocco, or from the deposits of Taudeni north of Timbuktu. "In the interior countries," he says, "the greatest of all luxuries is salt. It would appear strange to a European to see a child suck a piece of rock-salt as if it were sugar. This, however, I have frequently seen, although, in the inland parts, the poorer class of inhabitants are so very rarely indulged with this precious article, that to say a man eats salt with his victuals, is the same as saying, he is a rich man. I have myself suffered great inconvenience from the scarcity of this article. The long use of vegetable food creates so painful a longing for salt, that no words can sufficiently describe it." This is an important statement. We may compare it with an observation of an opposite character also recorded by Bunge, which completes and serves to confirm it. It relates to the astronomer, L. Schwarz, who, after living some three months with the Tunguses of Siberia on an exclusive diet of reindeer meat and game, lost the desire and the habit of adding salt to his food.

In America similar observations have been made. At the time of its discovery the greater number of the tribes of North America lived by the chase and by fishing. They used no salt, although it was very common in their prairies. A small number only were at that time sedentary and agricultural. These were fond of salt and undertook frequent wars for the possession of saline springs. Farther south, in Mexico, a sedentary people of more cultured character used salt regularly, while in the Pampas, covered with salt lakes and efflorescences, the Gauchos scorned a vegetable diet and the salt which seasoned it as food fit only for their beasts.

The examination of what has occurred in the people of the Indian archipelago and Australia supports anew the law of Bunge. Everywhere it is the populations devoted to agriculture that use salt. Everywhere, also, peoples addicted to the chase, to fishing, or to a pastoral life either disdain it or refuse to use it. Some European explorers who have, like Schwarz, adopted an animal diet have become accustomed to do without salt, while others, like Mungo Park, reduced to vegetable food only, have endured an almost painful hunger for this substance.



## II.

There is, then, a well-established relation between a vegetable diet and the need for salt and reciprocally between an animal diet and the exclusion of this article from food. We must now push the matter further and ask the reason for these remarkable relations. This is the problem formulated by G. Bunge, who, as a chemist, has advanced a very ingenious theory for its solution.

The answer might be very easy. If, for example, the difference between the two diets was that of a difference in the amount of salt which they respectively contained; if the food of vegetable origin was poor in common salt and that of animal origin rich in that substance, the solution would be clear; the law empirically established by Bunge would have a very evident explanation.

But the matter is not so simple. The two kinds of diet are not distinguished from each other by the quantity of salt which they contribute to the organism. In fact, both kinds are very poor in salt.

If we examine food as it comes from plants or animals we find that the greater part of it is tasteless and insipid, insufficiently salted for our taste. The albuminoids of meat, the fats, the starch of cereals and leguminous plants, do not, by themselves alone, exercise any action upon our gustative sense. The flavor of our food comes from secondary products, from aromatics and odors that are added in some way; to be exact, from foreign substances existing in very minute quantities, ethers, acids, and essential oils that culinary preparation and cooking only develop to a greater degree. In general, natural food is but slightly saline.

Since the small quantity of common salt contained in natural aliments suffices for our needs when the diet is confined to animal food, it ought to answer for them in the case of a vegetable diet. Why is it otherwise? Whence comes it that one of these methods of alimentation requires the artificial addition of salt? Chemists have ascribed the cause of this peculiarity to the different composition of the two kinds of food. Although both contain equally small quantities of chloride of sodium, they are distinguished from each other by another mineral product which they possess in an unequal though considerable degree. This is potash. In marked contrast with common salt, this substance, always abundant, varies very greatly in its relative quantity in different kinds of food. There are foods that contain a great deal of it, and these are precisely those that are taken from the vegetable kingdom. Plants are generally distinguished by their richness in potassic salts. They accumulate enormous quantities of them, drawing them from the poorest soils. Indeed, before the discovery of the mines of Stassfurt, the incineration of green plants was the only source of industrial potash. Inversely, there are other aliments derived from animals that

are generally relatively poor in these compounds. In fine, the capital difference—we do not say the only one—that distinguishes in the eyes of the chemist the two modes of diet, is the abundance of potash in the vegetarian ration and its deficiency in the meat ration.

If we make a list of foods arranged according to the increasing quantity of potash which they contain, it will be seen that animal substances (blood, milk, meat) stand at the head, while lowest are vegetables (beans, strawberries, potatoes, clover). Still, there are some remarkable exceptions. Rice, for example, is very poor in potash, a kilogram of rice in a dry state furnishing only a gram. It is true that it furnishes still less soda (33 times less). In this respect a rice diet approaches an animal diet; and, in fact, provokes but a slight appetite for salt. On the contrary, a kilogram of potatoes contains 24 grams of potash and 60 times less of soda. This food approaches, from this point of view, the vegetarian type in its perfection.

The information given us by chemical analysis may then be succinctly stated as follows: The vegetable kingdom furnishes the economy with much potash and very little soda—about 25 to 150 times more potash than soda. On the other hand, the animal kingdom reduces the supply of potash without reducing in the same degree the supply of soda. It introduces into the economy no more than 2 to 5 times as much potash as soda.

All this is perfectly true and interesting in itself, but it may be asked what it has to do with the question we are considering, and what hidden relation there is between the proportion of potash that distinguishes the two diets and the inequality in the need for salt which they produce. M. Bunge believes that he has discovered this relation. His hypothesis is that potash is responsible for our like or dislike of salt in cookery. This he justifies by a series of closely connected inductions. The need for salt is the consequence of the loss of salt from the organism, as thirst is the consequence of the loss of water due to hemorrhage, transpiration, or other causes. The need for salt implies a previous loss of salt. Secondly, the loss of salt should be a phenomenon of a chemical nature resulting from reactions of disintegration. Thirdly, this chemical phenomenon having, as is proved by experiment, a relation to the different kinds of diet, should be caused by their chemical characteristics—that is to say, by the difference in their proportions of potash. That is his doctrine. Theory having led him to this point, the rest is a simple matter for the clever chemist of Basel; he has no difficulty in discovering the mechanism by which the vibrations of the potash introduced into the system control the proportion of salt that is eliminated.

When a theorist declares that something *should* be, he usually suspects that it *may* be otherwise; this occurs twice in the reasoning which we have just cited. Hence, there are two weak links in the

chain of argument. Therefore the principle of this theory is uncertain and may be contested. Indeed, it has been.

It is possible, contrary to the reasoning of Bunge, to increase the relative and absolute quantity of potash taken into the system without increasing the appetite for salt; indeed, we may even decrease the desire for it.

An example of this sort is found among the negro tribes of Africa who use "*ash salt*." The use of this mineral condiment extends throughout a large part of central Africa in the basins of the Ogove and Sanga north of the Congo and in the provinces of the Free State to the south on the opposite side of the river. The lack of sea salt or rock salt causes these populations to replace this substance by another saline material which they prepare on the spot by their own means.

But this is not ordinary salt—chloride of sodium; it is not even a soda salt. They obtain this spurious salt from the ashes of plants. Not the first that come to hand, for it is not immaterial what plants are chosen for this purpose. On the contrary, they are carefully selected species. They use particularly two plants from the river. The favorite one is a floating aroid common on the Ogove and determined by M. Lecomte as the *Pistia stratiotes*. It is said that at certain places this plant is cultivated solely for the purpose of extracting its salt. The second is a sort of high bamboo that grows in clumps upon inundated banks.

What peculiarity have these plants that causes them to be chosen to the exclusion of others? We do not know. M. L. Lapieque, from whom we have derived a part of this information, supposes that it is the slight proportion of carbonates that they furnish when incinerated, or as the effect of subsequent treatment. In a product destined for food, the lack of alkaline carbonates is a decided advantage, for their nauseous odor and alkaline taste is repulsive to all.

After being harvested the plants are dried and then burned; the ashes are collected and leached. At Berberati, on the Upper Sanga, Dr. Herr witnessed this process. The aborigines use for this purpose a rude filter made of a conical basket, in which the ashes are placed. Through this water is passed and repassed several times to dissolve out all the soluble salts. The solution thus obtained is then evaporated by heat. The fixed residue forms the "*ash salt*."

The composition of this salt, at least as to its general features, is well known. M. Dybowski, in 1893, communicated to the Academy of Sciences some analyses of it. Its composition varies little from that furnished by most plants similarly treated. Normally, as has been already said, potash is greatly in excess of soda in all vegetables. The proportion varies from 30 to 150 parts of potash to 1 of soda. That is what we find in this case; the quantity of soda is very minute.

The characteristic features of the chemical composition of these plants would then be an abundance of chloride of potassium and a scarcity of carbonates.

This spurious salt tastes much like common salt, but leaves the sharp after taste of potassic salts. It is not, on the whole, decidedly disagreeable to a European palate; the aborigines prefer it to common salt.

The strong appetite which these sedentary, agricultural negroes have for this mineral condiment quite justifies the rule established by Bunge, according to which the need for salt is connected with agricultural habits and vegetable diet. And if this appetite is manifested here not only for true common salt but for a sort of spurious salt, the law is still better exemplified. Bunge goes so far as to say that in this case observance of the law is carried even to aberration, but, on the other hand, it will be readily seen that the theory devised by the chemist of Basle to explain his rule is undermined by this very example, for this need for salt being due, according to him, to the waste of chloride of sodium from the organism, which, in its turn, is indirectly caused by an excess of potash in the food, should only be remedied by restoring the lost chloride. But in this case the ash salt that appeases and satisfies the need is a salt of potash, and so ought, theoretically, to exasperate it.

The explanation of Bunge is therefore not tenable. All that experience teaches is that an exclusive vegetable diet causes a need, a particular appetite, which can be satisfied by substances having the taste of cooking salt and containing either chloride of sodium or chloride of potassium. In brief, from a chemical point of view, it is a need for chlorides; from a physiological point, a need for salty savor; that is to say, for a particular kind of gustative sensation.

### III.

One of the effects of the progress of civilization has been to substitute a mixed diet for that of primitive peoples, this latter being sometimes exclusively animal, at others exclusively vegetable. At the same time the use of salt has become general and is now a universal habit, but we have just seen that its use was originally limited to vegetarian peoples and had its origin in a need either for a material constituent of the body or for a sensation.

Which of these two alternatives is the true one? Must we admit, with Bunge, that we have a true chemical need, an appeal, an attraction of the organism for a substance necessary for its constitution and, at the time, deficient? Is it not, rather, merely a need of the senses, a sort of protest of sense against the habitual tastelessness of vegetable foods which has to be remedied by a condiment otherwise inoffensive?

This is the conclusion of the greater number of physiologists. It is that of M. Lapieque, who sees, in the appetite for salt, a particular case of a very general taste for condiments common to all populations that live on vegetables: To the Abyssinians, who counteract with *berberi*, a sauce spiced with pimento, the insipidity of their durrha or Indian millet; to the Hindoos and Malays, who mask with curry the tastelessness of rice, the basis of their diet. This is also the opinion, of far greater antiquity, of Sallust, who, speaking of the salt disdained by the Numidians, ranks it among the *alia irritamenta gulae*.

In reality, one may reconcile these opinions and bring Bunge into agreement with Sallust and M. Lapieque. The sole function of condiments is not that of rendering agreeable the enforced task of eating and of transferring into a pleasure the necessity for food. The gustatory sensation is not wholly for the pleasure it gives; it is charged with an important function relating to the operations of the digestive apparatus. As Professor Pawlow and his pupils have recently shown, it starts into action the vital energy of the stomach and induces the secretion of an efficient gastric juice, rich both in acid and in ferment (pepsin). Even the contact of the food with the mucous membrane of the stomach, which physiologists have until recently supposed to be the only means of arousing the secretion of that organ, does not have as much effect as the sensory excitation due to sapid substances. The gustatory impression is more efficacious. It causes a more abundant secretion of gastric juice, which is more energetic in its action and therefore of greater value.

Condiments and seasonings are therefore found to have a justification that is to some degree of a physiological character. They insure the proper action of the stomach.

Salt does more. At the same time that it puts in motion the secretion of the stomach it furnishes it with materials, at least with some of them. Hydrochloric acid, which is characteristic of the gastric juice and insures its digestive efficacy, is derived from salt, from the chloride of sodium of the blood. The same origin should be ascribed to the chlorine compounds found in the juices of the stomach, fixed chlorides and organic chlorine. In other terms the material for the chlorine compounds of the gastric juice comes primitively from the salt of our food.

This is not the place to discuss how, in order to produce this result, the salt of the blood is decomposed within the gastric glands. This is a problem that has greatly occupied modern physiological chemists, and upon which they as yet do not fully agree. Maly has supposed one kind of mechanism for this reaction, Laudwehr another. The method matters little. That which should be noted is the fact that salt is destroyed by gastric digestion, and that the equilibrium of the organism demands that it be replaced. If, then, the loss of salt is not,

as Bunge supposes, the primary cause for the need for salt so general among all peoples, it is at least its consequence and its physiological justification.

Any other chloride than that of sodium susceptible of introduction into the blood may there participate in similar reactions and play the same part.

The ash salt, rich in chloride of potassium, is a good substitute for cooking salt. Recent experiments have led MM. Dastre and Frouin to conclude that chloride of magnesium may be used for the same purpose with still more striking results. The secretion of gastric juice, which increases in quantity by the introduction of common salt into the blood, is still more increased by the introduction of the magnesium salt.

The same result would be obtained by the introduction of the spurious ash salt prepared by the negroes of the Ogove and the Sanga as by the use of common salt; still better results by the magnesium salts if other reasons did not exclude their employment. In the absence of salts belonging to the same group as common salt we may even substitute, as has been shown by the well-known chemist, E. Kütz, others farther removed, such as the alkaline iodides and bromides. These give rise to a gastric juice acidified by hydriodic and hydrobromic acid instead of by hydrochloric acid as is normal gastric juice. Still, if such a substitution in no way affected the functions of the stomach, it might not be the same in relation to other organs.

#### IV.

Ordinary salt, the chloride of sodium, is one of the constituent elements of animal organisms, existing everywhere in them. The blood has a saline taste more or less marked; all the secretions are salty; the tears themselves are more salty than bitter, whatever good people may say about them. Salt water, in fact, bathes all living particles and leaches continually from the organic structure, escaping from all its issues, carrying with it the waste matters which should be rejected from the body.

Common salt is more suitable than any other for this purpose. In a dose of 9 grams per 1,000 it forms a solution innocuous to the anatomical elements, that can circulate around the most delicate of them without causing the least damage. This close association with salt has become habitual to them from immemorial usage; they have adapted themselves to it, and it would lead to some inconvenience if another mineral constituent should be too abruptly substituted for it. In certain animals that have been bled to exhaustion, life may be kept up for some time if the blood is replaced by a saline solution, named, because of its properties, the physiological solution. A turtle or a frog in whose veins this fluid circulates continues to live for a con-

siderable time. Certainly this is not a generous liquor; the living alimentary particles find in it nothing by which they can be nourished and sustained, and they can live in it only as long as their own reserves may last, but at least it does them no harm.<sup>a</sup>

We may now begin to comprehend what becomes of the salt we consume in obedience to the curions need of which we have spoken. It is easy to predict its destiny. The greater part of it will remain in simple solution; the remainder will enter into combination, more or less intimate, with living matters. The former will penetrate into the circulating liquids, lymph and blood, and will with them pass through all the systems of the body without taking any direct part in the vital changes, but, on the contrary, act merely as a filling, neutralizing by the number of its molecules the danger which the cellular community would incur if the medium in which it lives were too much diluted, and it will finally pass out by the natural emunctories, invariable, unchanged, but having performed the service of removing from the economy the effete products of cell life. This eliminated salt must be replaced. Its loss, reacting upon the organism, is the primary cause of the need for salt.

The second and smaller portion of the salt taken into the body will penetrate into the elements themselves, will make an integral part of them, will participate in their chemical changes, not only those which give rise to the gastric juice, but also others, finally becoming destroyed and lost to the organism. The void left by this continual elimination has doubtless some weight in the sensation of need for salt, which the animal feels. It is a second element of it.

## V.

The necessity for common salt in the food results from this series of changes. The organism could not be maintained, or, in other words, health would be impaired if that which was lost were not restored. Mineral aliments are therefore a necessity. It is necessary that we should have salt. There are some physiological functions in which common salt may be replaced by another, as we have seen in the case of the gastric secretion, but there are others for which such substitution is, probably, impossible. A modicum of chloride of sodium is indispensable to life.

In truth neither men nor animals have to occupy themselves in

---

<sup>a</sup>A solution of this character, having the proportions of about 6 parts of chemically pure sodium chloride to 1,000 parts of distilled water, rendered aseptic and warmed to 100° F., is in common use in surgery and medicine, being known as the "normal salt solution." Readers will doubtless recall that it was used in the lamentable case of President McKinley, both for the cleansing of the abdominal cavity during the surgical operation and later as a hypodermatic injection. It was also used some months before with good effect in the treatment of Mrs. McKinley, who was suffering from a disorder that had drained the blood of its fluid.—TRANSLATOR.

finding this modicum. It is exceeded by the quantities normally existing in natural foods. The difficulty, then, is not in obtaining the nutritive substances which contain this modicum; it would rather be in devising a food sufficient in other respects, that is to say, as regards nitrogenous, fatty, and starchy matters, in which this modicum did not exist.

Nevertheless a physiologist, Forster, in 1864, was able to do this. He utilized the waste from meat powder derived from the manufacture of Liebig's extract, treating it several times with boiling water, so as to wash away almost all the soluble salts. With this leached meat, together with starch and fat, he formed a ration in which there was wanting nothing but the mineral salts.<sup>a</sup>

Animals nourished with this ration in reality suffered from mineral inanition. The experiment of Forster, carried out at Munich under the direction of Voit, is, in fact, a typical one of this kind and perhaps the only one performed until latterly, when Bunge and other physiologists took up the matter again.

The necessity for mineral alimentation was affirmed as a general principle as early as 1861 by Liebig in his *Letters on Chemistry*. It is true that Chossat and Boussingault had called attention to the necessity for lime and that Becquerel and Rodier had spoken of the need for iron; but these were only special studies. Liebig stated the general principle: animals require for their proper maintenance albumenoids, fats, either starches or sugars, and mineral aliments; but it was not Liebig who demonstrated this, it was Forster.

In fact, the experiment of Forster relates to the entire sum of mineral matters, not specially to the chloride of sodium. It is an example of complete *mineral* inanition, not of *saline* inanition. It furnishes, however, some information as to the consequences which may follow from the suppression of salt in alimentation. As soon as the regimen was established, the animal showed a considerable diminution in the quantity of salt rejected by the emunctories, though the urea and the organic waste products maintained their usual proportion. The organism, then, retained its mineral matters; the mutations of chloride of sodium engaged in organic combinations were slight. After twenty-six days of this method of alimentation the animal had lost but 7 grammes of this chloride of sodium in combination. Its health, however, was much impaired. It grew more feeble day by day. Nervous troubles appeared, consisting at first of habitual inertia, paralysis of the limbs, and later of convulsive seizures and attacks of madness. The gastric secretion diminished at once. Toward the last it no longer contained hydrochloric acid. Grave digestive disturbances finally intervened. The animal, however, lost but little in flesh; its pining away, its corporeal and physical failure, was but the result of the

---

<sup>a</sup>There remained but eight-tenths per cent of the dry weight.



suppression of mineral salts. The lack of common salt was, doubtless, but a single factor in the production of these phenomena. The absence of other salts, particularly of the phosphates, had also something to do with it. Nevertheless, it is striking to see what violent disturbances may result from slight variations. In fact, the animal succumbed more quickly from the deprivation of mineral elements alone than it would have done from total inanition, that is to say, from the suppression of all aliments except water.

The necessity for a modicum of common salt is shown by these experiments. Chloride of sodium is then a plastic aliment. It is placed by Munk and Ewald in the category of nutritive salts together with the alkaline and earthy phosphates and the salts of iron. According to statistical data the daily consumption of salt in Europe is on the average 17 grams per capita. Of these about 2 grams are necessary to cover the loss by disassimilation. These two grams represent *nutritive* salts. The remaining 15 grams would then represent on the one hand 8 to 10 grams carried away by excretions and necessary for restoring the constitution of the circulating liquids, and a surplus; but, considering the influence of salt upon the secretions, it would not be prudent to say that this surplus is a sacrifice made to the pleasures of appetite.

We have just seen the ill effects of a deprivation of salt. We should perhaps say a word about those which result from its excessive use. It is known that if taken in amounts beyond the average it causes thirst, and an increase in the renal excretion. It has been shown that this increase remains about the same whether or not the subject drinks. The water excreted is then taken from the tissues.

If the absorption is pushed beyond moderate quantities, vomitings and intestinal disturbances ensue. This kind of excess has rarely been observed unless we regard as authentic the story of those midshipmen who are said to have been compelled by Peter the Great to drink sea water for the purpose of inuring them to a sailor's life and who died as a consequence.

## VI.

Besides taking an active part in certain of the vital phenomena, common salt fulfills better than any other substance the conditions of a medium that is indifferent and yet suitable for the physiological necessities of living matter. In animals as well as in plants, in the mobile corpuscles of the blood as well as in the fixed elements of the tissues, living protoplasm is always rich in potassic salts. The interior medium which bathes it abounds, however, in sodic salts, particularly the chloride of sodium, resembling in this respect sea water, which might, if properly diluted, circulate in the veins and replace for a time the plasma of the blood, as we have seen may be done with the

physiological solution. Some naturalists, recalling the circumstances under which life appeared on the globe, and the manner in which it was for a long time maintained in the saline waters of the Palæozoic seas, have thought they perceived in this fact the survival of an ancestral condition.

From this point of view chloride of sodium would be an element handed down from remote times, belonging to a medium suitable to animal life, to the blood and to the organic humors; and salted food, by introducing it about the anatomical elements of the body, would recall the marine origin of animal life, would connect, as one may say, the physiology of the present with that of the past. \* \* \*





THE AIR SHIP "SANTOS-DUMONT V" CIRCLING THE EIFFEL TOWER.

"Bringing together man's two ways of getting into the air, the one from a century just closed, the other from a century just beginning." [The balloon was really no higher than the second platform; but the camera, pointed upward, made it appear to be near the top.]

## SANTOS-DUMONT CIRCLING THE EIFFEL TOWER IN AN AIR SHIP.<sup>a</sup>

By EUGENE P. LYLE, JR.

As early as 3 o'clock of the morning of July 12, 1901, a curious procession emerged from a hillside inclosure on the bank of the Seine and proceeded toward the silent race course of Longchamp across the river. Besides several correspondents, this party was composed mostly of young Parisians, who slowly steered their automobiles while they bent their heads back and looked upward. Following them, a few yards in the air, there floated a strange, mysterious shape, dim and yellowish against the hazy dawn. Several men on foot guided the aerial contrivance by ropes which they clung to jealously. Their care was natural, for they held in leash the first flying machine; and by "flying machine" is meant one that really has flown, and which deserves its name literally, being far, far removed from the monotony of the many failures gone before. But the young Parisians did not know as yet that it would fly, for this was to be its first trial—its debut in the air—and not one among those gathered to witness it suspected that he was to assist at a spectacle which history may possibly compare with the launching of Fulton's steamboat or with the firing of the first locomotive.

At the race track the balloon was pulled down till the framework rested on the ground. A young man, 25 years of age, went hurrying about the air ship, tinkering at it here and there till the very last moment, while his comrades of the Automobile and Aero clubs looked on and respectfully let him have his way. He was a very little man, in-shirt sleeves and a high collar, with an almost effeminate speech, and very amiable, but he seemed to know pretty well what he was about. When he had examined the tube which connects a cigar-shaped gasoline tank with the motor, he wrapped a strap around a wheel of the motor, pulled the strap off again with a sharp jerk, and thus set the motor going. Involuntarily the spectators jumped back, for the gasoline engine with its four cylinders starts with a crashing explosion, so closely followed by others that the deafening, bursting combustion is almost continuous; yet through the framework there is scarcely any vibration at all, only a slight quivering.

<sup>a</sup>Reprinted from Everybody's Magazine, Philadelphia, November, 1901. Copyrighted, reproduced by permission of Doubleday, Page & Co.

FOR THE FIRST TIME IN HISTORY AN AIR SHIP OBEYS HER RUDDER.

Before climbing into his basket, the slender little aeronaut took a final look up at the sky. He had spent the last two nights near his balloon, patiently waiting for favorable weather. He seemed satisfied now, and climbed into his tiny car, which is just a narrow crating of willow fixed into the forward nose of the triangular framework. The guide rope was slackened and the balloon lifted him slowly from the ground. He gave a signal and the guide rope was released. The balloon bounded into the calm air. Those below, bending back their necks, saw in the stern two big fans, the screw of the vessel, begin to turn. They watched breathlessly, for the question of that moment was, Would those fans serve as wings, or would the balloon prove only a balloon after all, obeying no will other than that of the breeze? That has ever been the question when some outlandish contrivance would mount into the air, and hitherto the answer at best has been only a sadly qualified negative. But this latest contrivance of the series appeared to be acting deliberately and rationally. She pointed her nose slightly upward and rose higher. Her rudder shifted and she slowly began to turn, and, following the track, made the circuit of the race course. On nearing the spectators the vessel pointed her nose downward and slowly descended. A moment later the little aeronaut climbed from his basket to the ground as one might alight from a bicycle. But the blood was stinging in his face, and joy fairly burned in his eyes. He appreciated, though only vaguely, what he had done. He had been striving to do this same thing with one balloon after another for a number of long, patient years. Before night of that day his name was known all over the world.

Once more, then, this little Brazilian aeronaut, Alberto Santos-Dumont, climbed back into his basket. He said that he would make the round again, and with a gesture indicated his intended landing place. He mounted as easily as before, swept around the track, and descended neatly on the spot he had pointed out. This was certainly an accumulating of evidence, and he had to believe that this last air ship of his, the *Santos-Dumont V*, had proved a success on her first trial. It was as simple as spinning around the track on an automobile. Four more times he did the same thing. His chariot was perfectly manageable, and answered the rudder as docilely as a good horse does the reins. During all the experiments of that morning he had no recourse whatever to ballast, and was yet entirely master of his altitude. This was due to the guide rope, a heavy cord several hundred feet long, hanging from the forward nose of the car. By pulling it toward the center of equilibrium or letting it out again, he could incline the axis of the balloon, pointing her up or down, and then, by propulsion of the fans, he could mount higher or drop lower at will. Sometimes he attained a speed of 25 miles an hour.



FIRST FLIGHT AROUND LONGCHAMP, FRIDAY, JULY 12, 5 A. M.

"This latest contrivance \* \* \* appeared to be acting deliberately and rationally. She pointed her nose slightly upward and rose higher."



THE RETURN FROM THE SECOND FLIGHT AROUND LONGCHAMP, JULY 12, 5.35 A. M.

"Swept around the track, and descended neatly on the spot he had pointed out."







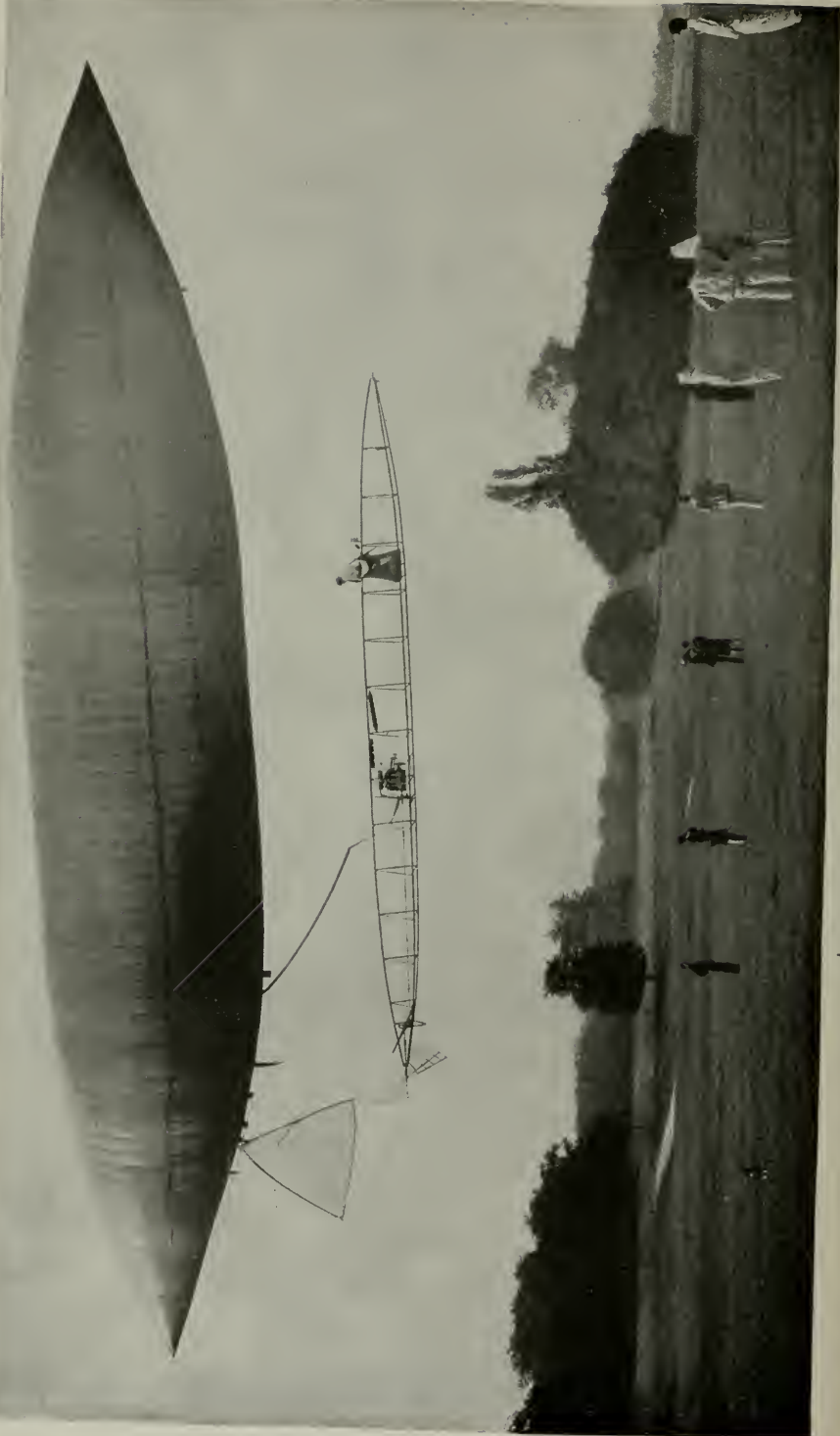

LEAVING FOR THE TROCADERO, JULY 12, 7.05 A. M.

These triumphs tending to make him more ambitious, he bade his friends au revoir and sailed off for the near-by station of Puteaux, returning very soon without touching ground. It was now that he declared for the little flying trip around Eiffel Tower. He refilled his petroleum can and off he started at an encouraging rate, while his friends stared after him, still too dazed for the hysterics of enthusiasm which were soon to possess them.

#### FROM LONGCHAMP TO THE EIFFEL TOWER THROUGH THE AIR.

The distance from Longchamp to the tower is a little more than 3 miles, but the airship made it in ten minutes, keeping at an altitude of from 100 to 300 yards. It is difficult to imagine what must have been the astonishment of early-morning visitors on the tower when they saw a man in a flying machine come soaring near them and genially waive them his greetings.

The bizarre traveler rounded the tower and was returning whence he came when one of the gear cords of his rudder broke. So, as naturally as a wheelman dismounts to repair a puncture, he came down into the Trocadéro Gardens, borrowed a ladder, climbed up the side of his balloon, tied the cord, and remounting, proceeded on his way back to Longchamp. Counting in the delay, he had been gone one hour and six minutes.

By this time the party at the race course had recovered sufficiently from their amazement for more or less intelligible congratulations. He had solved the fatuous problem of aerial navigation—that was their refrain. And almost the entire press of that day supported their words. He had undoubtedly steered a balloon. The two essentials were there, and they had worked effectively, namely, the propeller and the rudder. He had sailed the four points of the compass, he had sailed in circles, and he had sailed up and down, and the bulky aerostat of Count Zeppelin over Lake Constance was now rated as an insignificant step, while the real, great stride had just been achieved by the young Brazilian. So his companions insisted that he should try at once for the Grand Prix.

#### THE BALLOONISTS' GRAND PRIX AND ITS CONDITIONS.

Now it should be explained that the Grand Prix referred to is the official goal of balloonists. A wealthy member of the Aero Club, Henry Dentsch, founded the prize last year. The amount is \$20,000, but the conditions seemed too preposterous; very ingenious, only impossible. The conditions prescribe that the winning aeronaut shall start in his airship from the Aero Club Park (the inclosed hillside on the Seine near Longchamp), sail to and around the Eiffel Tower, and return and land in the park, a trip of about 8 miles, without touching

ground or aught else in the meantime, and all within the maximum time limit of a half hour. Although this offered a definite incentive to plunge into what was one of the most fascinating impossibilities of the future, only the flying-machine inventors—the synonym of a disordered mind—regarded flying machines with any respect. This fascination had long enslaved the rich young Brazilian, when one day the Grand Prix was founded, and he constructed his *Santos-Dumont IV* to win it, seeking thereby the official recording of a definite triumph. For him the \$20,000 would be merely a little purse for the building of more air ships. But before he housed his aerial pet, *Santos-Dumont V*, in the balloon shed at the park that morning of July 12, he announced to his friends that he would try again for the Grand Prix.

#### A SECOND FLIGHT TO THE TOWER BEFORE THE PRIZE COMMITTEE.

At 4 o'clock the next morning, July 13, the sky was mottled with clouds, while a choppy wind blew from the west; but as there was no change for the worse by 5 o'clock, Santos-Dumont began making preparations for his flight. Long before he was through with testing the parts of his machine, a crowd had begun to gather in the park—wheelmen, chauffeurs, photographers, and correspondents. At 6.20 the great sliding doors of the balloon house were pushed open, and the massive inflated occupant was towed out into the open space of the park. The big, pointed nose of the balloon and its fish-like belly resembled a shark gliding with lazy craft from a shadow into light waters. In the basket of the car stood the coatless aeronaut, who laughed and chatted like a boy with the crowd around him. The prize committee was there and expressed its hopes for a successful trial. This committee is composed of Count Henri de la Vaulx, the vice-president of the Aero Club, who intends shortly to cross the Mediterranean in a balloon; Prince Roland Bonaparte; Henry Deutsch, and two members of the National Institute, MM. Bouquet de la Grye and Cailletet.

From the very first the conditions did not show themselves favorable for the attempt. The wind was blowing at the rate of 6 or 7 yards a second. The change of temperature from the balloon house to the cool morning air had somewhat condensed the hydrogen gas of the balloon, so that one end flapped about in a sadly flabby manner. Air was pumped into the air reservoir, or ballonet, inside the balloon, but still the desired rigidity was not attained. But, more discouraging yet, when the motor was started, its continuous explosions gave to the practiced ear signs of mechanical discord. It should be stated that this motor can be started only from the ground, by the strap twisted around the wheel, as already mentioned. Once the motor stops while in air, there is no way to set it going again without coming down to earth.

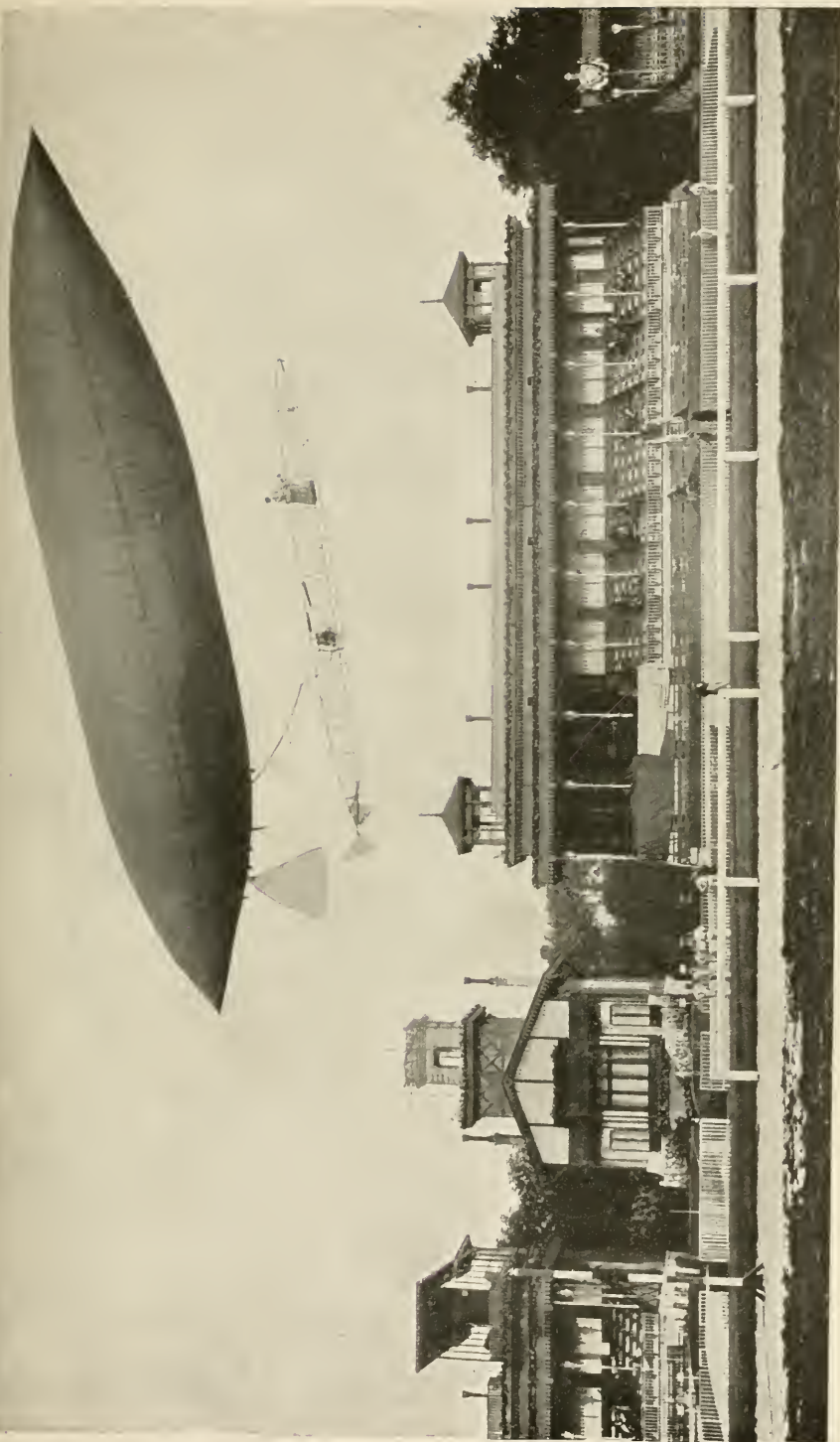

SECOND FLIGHT AROUND LONGCHAMP, JULY 12, 5.30 A. M.

“He said that he would make the round again, and with a gesture indicated his intended landing place.”







RETURN FROM THE TROCADERO, JULY 12, 8.10 A. M. SANTOS-DUMONT CRAWLING OUT OF HIS BASKET.

“He had solved the fatuous problem of aërial navigation—that was their refrain, and almost the entire press of that day supported their words.”



IN THE PARK OF THE AËRO CLUB. SANTOS-DUMONT PREPARING FOR HIS FIRST OFFICIAL TRIAL AROUND THE EIFFEL TOWER, JULY 13, 6.30 A. M.

“The big pointed nose of the balloon and its fish-like belly resembled a shark gliding with lazy craft from a shadow into light waters. In the basket of the car stood the coatless aëronaut, who laughed and chatted like a boy with the crowd around him. The prize committee was there and expressed its hopes for a successful trial.”



Nevertheless, Santos-Dumont, with his sleeves rolled up, fixed himself once more in his basket with much the same air as a workman seats himself before his lathe for the day's work. His eye took a careful survey of the entire air ship lest some preliminary had been overlooked. He counted the ballast bags under his feet in the basket, he looked to the canvas pocket of loose sand at either hand, then saw to his guide rope. Everything appeared to be all right. Several friends shook his hand, among them Mr. Deutsch. Count de la Vaulx, with watch in hand, stood ready to begin counting the official time. The chattering stopped, and the place was very still as the man holding the guide rope awaited the signal to let go. Then the little man in the basket above them raised his hand and shouted. On the second the timekeeper (Count de la Vaulx) called off 6.41, and man and balloon would have to be back by eleven minutes after 7.

At first it did not look like a race against time. The balloon rose sluggishly, and Santos-Dumont had to dump out bag after bag of sand, till finally the guide rope was clear of the trees. All this gave him no opportunity to think of his direction, and he was drifting toward Versailles; but while yet over the Seine he pulled his rudder ropes taut. Then slowly, gracefully, the enormous spindle veered round and pointed its nose toward the Eiffel Tower. The fans spun energetically, and the air ship settled down to business-like traveling. It marked a straight, decided line for its goal, then followed the chosen route with a considerable speed. Soon the chug-chugging of the motor could be heard no longer by the spectators, and the balloon and car grew smaller and smaller in its halo of light smoke. Those in the park saw only the screw and the rear of the balloon, like the stern of a steamer in dry dock. Before long only a dot remained against the sky, but the dot was still moving. Steadily it neared the shadowy obelisk line which was Eiffel Tower, then scarcely visible in the heat mist of Paris. Suddenly the dot vanished behind the tower, thus bringing together man's two ways of getting into the air, the one from a century just closed, the other from a century just beginning.

To the throng waiting in the park the dot seemed blotted from sight for a long while, but at last they could distinguish it emerging from the foggy ladder-shape outlined against the sky. They could not tell, however, whether it had really gone around the tower. If Santos-Dumont had not doubled the tower, then the greater interest in his return was lost. It would be no longer a race. Still the people kept count of the minutes as they watched the speck grow larger and larger, and gradually evolve into the form of an air ship. The morning sun caught on the burnished copper of the petroleum reservoir, and the man could be seen in his car, and then a messenger in an automobile raced up to the park gate. He brought the marking of the official timekeeper on Eiffel Tower, and his announcement laid all

doubts. The *Santos-Dumont V* had doubled the tower, he announced, passing 20 yards to leeward, time 6.54. That meant half the journey in thirteen minutes, a gain of two minutes.

#### WAS THE GRAND PRIX WON?

The crowd gazed upward to the still distant balloon, and some in their enthusiasm yelled to the aeronaut to hurry, hurry faster. The grand prix was won, of that everybody was certain. But as the minutes were counted off, and the balloon did not seem to be approaching with the speed expected, doubts began to grow among the eager ones. Only four minutes left, only three. Was he going to lose, after all? There he was, steering far above the river, and they could even hear the popping of his motor. Evidently something was wrong. The air ship labored desperately in the face of the wind, and when at last it hovered over the park the time was 7.22—eleven minutes late. And yet he had not landed. Instead, the wind swept him back across the river. Twice he returned with extreme difficulty; and then, suddenly, the motor stopped. With that the *Santos-Dumont V* was as an ordinary balloon, and she went with the wind, off over the Bois de Boulogne. A moment later she came down heavily and disappeared in the trees.

#### A CATASTROPHE IN THE GARDEN OF BARON ROTHSCHILD AND THE RESCUE BY A PRINCESS.

A dozen friends sprang to their automobiles and raced away in that direction. Each one dreaded finding Santos-Dumont probably mangled and lifeless. They found him on his feet, with his hands in his pockets, reflectively looking up at his airship among the top branches of some chestnut trees in the grounds of Baron Edmund de Rothschild, Boulevard de Boulogne.

"I should like to have a glass of beer," he announced, which called forth a nervous laugh of relief.

Now, next door to Rothschild lives His Royal Highness, the Comte d'Eu, and from a window Her Imperial Highness, the Comtesse d'Eu had been watching the antics of the flying machine and its finale. Her imperial highness is a daughter of Dom Pedro, of Brazil, and consequently a compatriot of young Santos-Dumont. As there ought to be a princess somewhere in an airship story, it proved quite convenient that her imperial highness lived next to the Baron Edmund de Rothschild, for she sent over a hamper of champagne and refreshments, with kind inquiries. Santos and his rescuers disposed of the champagne and refreshments; and then Santos, coatless, dusty, and mussed up, hurried over to thank the princess. Her highness spoke words of encouragement and pointed to Dom Pedro's picture, and then Santos went back to untangle his air ship from the chestnuts.



THE START ON THE FIRST OFFICIAL TRIAL AROUND EIFFEL TOWER, JULY 13, 6.41 A. M.

"The little man in the basket above them raised his hands and shouted. On the second the timekeeper (Count de la Vaulx) called off 6.41, and man and balloon would have to be back by eleven minutes after seven."



TAKEN FROM THE EIFFEL TOWER, JULY 13, 1901. THE BALLOON IS OVER THE TROCADÉRO, ABOUT ONE HUNDRED YARDS AWAY.

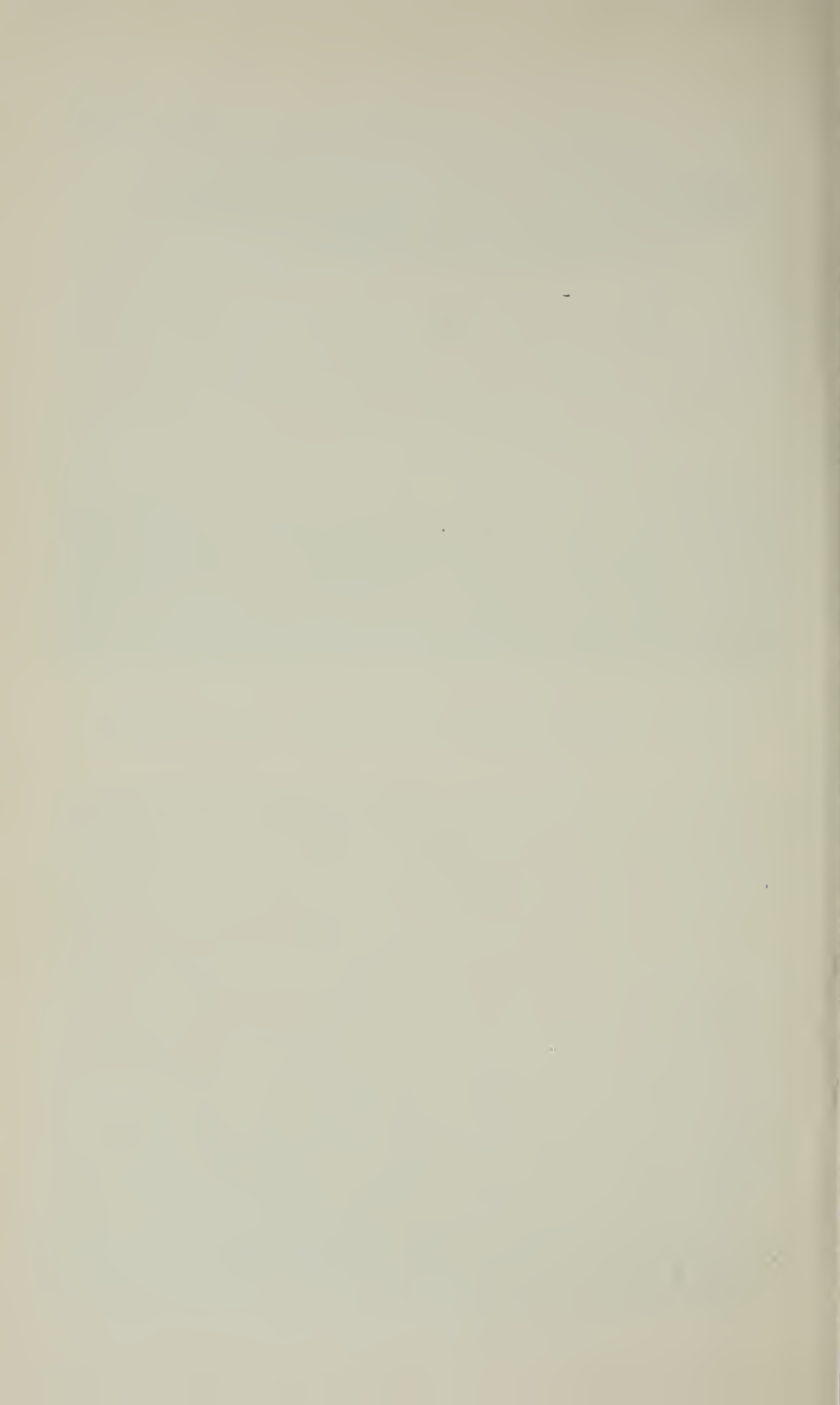

When he had cut the wires between the balloon and the car, he discovered, greatly to his surprise, that the damage was really nothing. The delicate skeleton framework was unhurt, except for a slight spraining of the propeller shaft. Then the young man was jubilant, for his treasure had certainly looked like a wreck. He could listen to questions at last, and he gave his story of the flight and fall, which you may be sure was listened to eagerly. To say nothing of the strong wind he had to fight against in coming back, his chief trouble was with his motor. Soon after going up one of the cylinders had stopped, and a little later a second. As he could not restart them, his motive power was thus cut down one-half for the rest of the trip, the motor at last giving out altogether. The wind, of course, carried him back over the river, and as he did not wish to come down in the streets of Boulogne beyond, and perhaps on top of somebody, and be taken up for reckless ballooning, he decided to come down quick where he was. So he ripped out a panel of silk and found himself in the tree tops.

But, after all, the only thing that kept him from winning the prize was the time limit. It must be considered, however, that the donor asks the competitors to do something in a half hour which has never been done before, although men have been trying for a century, and that is to steer a balloon. Weighed against a century, a delay of eleven minutes can not count for much against success.

#### PREPARATION FOR A THIRD TRIAL.

Within a week the *Santos-Dumont V* was all shipshape again, and awaiting good weather for another try at the Grand Prix. The weather, though, had been unobliging, and Parisians had haunted the Aero Club Park in vain. Sunday, August 4, Santos-Dumont did, in fact, start for another trial, but he had not gone a quarter of the distance when he turned around and came back. The guide rope was not working right. Another spectacle, however, rather offset the popular disappointment. When fully 600 feet in air, the plucky little fellow climbed out of his basket and moved around on the slender framework to adjust a cord that did not suit him.

#### THE TRIAL AROUND THE EIFFEL TOWER AND BACK.

It was on August 8, 1901, that M. Santos-Dumont made a third trial for the Grand Prix, with the odd-looking air ship constructed of two cigar-shaped balloons, with the car for the basket and motors suspended between them. Instead of disaster and destruction, he began with every prospect of success, and strengthened his claim as a navigator of the air. He started from the park at 6.12 a. m., under the best of conditions. His balloon rose quickly in the almost absolute calm, so that without loss of time he started the screw and veered round in a straight line for Eiffel Tower. The trip there was as a

bird's flight, clean-cut and unswerving. He gained and rounded the tower in nine minutes, a gain of four minutes over his first trial, or less than one-third of the time limit. He had, therefore, twenty-one minutes in which to make the same trip back. It would be stubborn hard luck that could keep him from the prize. But that is what happened.

The tower was no sooner rounded than difficulties seemed to begin. Without apparent cause the air ship suddenly pointed upward, and mounted 100 yards higher in air. Then it began to sink toward the roofs, bereft of buoyant force or vitality. It was beyond control, and its navigator was being tossed in midair, more helpless than a sailor clinging to a plank. He started the ventilators, to inflate the ballonnet with air and make the balloon rigid, but as a climax to despair the ventilators would not work. The balloon became flabby, and even its ends doubled on itself like a pocketknife. This brought the wires that suspend the framework into trouble with the turning screw, and in a moment several of them snapped. Just in time to save himself from being cut away from the balloon entirely and dashed to the ground, Santos stopped the screw, and then the unwieldy air ship dragged lower to the earth, and was soon skimming over some high hotels that had been built for the exposition. Once he was jolted against a cornice, and once again he was so low that his guide rope coiled along the ground. A carpenter seized the end and wrapped it around the iron bars of a window. But the breeze carried the balloon on, and with a jerk the guide rope tore out the iron bars. On the edge of the next hotel roof the balloon was stranded and wrecked. The framework, though, holding the heavy motor and the man, dangled from its wiring over the wall of the building. A moment it hung suspended, then its lower end settled on the roof of a two-story restaurant next door, and its upper end against the wall of the hotel. There was a space between the two buildings, and the framework spanned this space almost perpendicularly. The delicate wooden beams strained and cracked, ready to break and bring its load to the ground.

A company of firemen were on hand almost at once, and from the top of the hotel they threw a rope to Santos-Dumont, who tied it around his waist and allowed himself to be drawn up. He had not suffered a scratch, but he suffered much more than that when the firemen began to extract his beloved air ship. With each cracking of wood he shuddered as though it were a bone; yet despite his anxiety and the care of the firemen, the framework broke into halves, and was soon found to be irreparable, and the same fate met the balloon. The only consolation was the motor, which seemed to be unhurt.

"Now what are you going to do?" one of his friends demanded.

"Why, begin again, of course. One has to have patience."

And that same day he gave orders for another balloon, which will be the balloon of the air ship *Santos-Dumont VI*. The new air ship



THE AIR SHIP ABOVE THE PARK, TURNING TO THE LEFT, PREPARATORY TO HEADING FOR THE EIFFEL TOWER. THE OFFICIAL TRIAL OF JULY 13.

"Then slowly, gracefully, the enormous spindle veered round and pointed its nose toward the Eiffel Tower."





will be on the same pattern as the old, except with a slightly greater cubic capacity. It can hardly be ready for a prize trial, however, before the contests next spring. Still, Santos-Dumont knows now that he can navigate the air, and he is merely going to do again what he has already done.

But M. Santos-Dumont will soon have competitors, among them M. Deutsch himself, who expects to put in the field within a short time a colossus 65 yards long, with a capacity of over 2,500 cubic yards, and a gasoline motor of 60 horsepower.

#### A DESCRIPTION OF THE AIR SHIP.

Recall the flying machine of your imagination, and you will have ready-made for your mind's eye a likeness of this *Santos-Dumont V*. It is simply that conventional creature pictured in the usual wild tale of the future, the regulation cigar-shaped thing 'mid a vague complication of wings and rudders and cords and cylinders. The gas bag is a tremendous cigar, while the framework beneath for basket and motor is a smaller tremendous cigar. Now, there is a reason for this shape quite apart from the demands of twenty-first century romances. It would be as absurd to try to steer a spherical balloon as to guide a spherical steambot. The spindle form offers less resistance to air currents, so almost from their earliest experiments the flying-machine architects have adopted the cigar for a model. To secure rigidity they put an air balloon, or ballonet, inside the gas balloon, and when a cooling cloud or change of temperature contracts the gas, they pump air as needed into the ballonet, which makes the entire bag tight and snug. Santos-Dumont first fills his balloon as full as possible with pure hydrogen, and the inner balloon lies empty in the belly of the big one. He thus has as a margin against condensation the ballonet's capacity, 50 cubic yards. The ballonet fills with air automatically from a pump worked by the motor, and in case of expansion and too great pressure the springs in the valves are forced open and the air is let out first, and the gas afterwards, if necessary. In the photographs you may see the air duct hanging from the balloon to the pump.

The tiny steel threads that suspend the framework seem absurdly inadequate. Near the ends they are twisted into springs, which allow for a slight rocking caused by the motor's vibration. A few yards away the fine piano wires are invisible, and then the man in his aerial car appears to follow as a satellite under the balloon. The great yellowish bag of hydrogen,  $37\frac{1}{2}$  yards long,  $6\frac{1}{2}$  yards in diameter, with a capacity of 715 cubic yards, looks sleek and peeled, like the pigskin of an enormous Rugby football, and nothing at all like silk. Each panel in the texture has been rigorously tested under pressure and is capable of the maximum strain exacted. The elongated, triangular car beneath is constructed of three slender unpainted pine

beams with cross-pieces. When examined as it lies stalled the long length of the balloon house, this car appears altogether too delicate for carrying a man and an engine several hundred yards over the house tops. Though over 59 feet long, it weighs only 110 pounds, and early in the spring of 1900 the inventor was able to pack it in his trunk by sections, bringing it from Nice, where it had been made during the winter, to Paris. The carefully chosen strips, bent to form the long curves of the triangular frame complete, are never thicker than two of your fingers put together. During this spring he remounted them in his workshop at the Aero Club park, the workshop being also the great barn of a balloon house. He made the joints of aluminum and fastened the cross-pieces with thin steel wire. About 8 yards from the stern he suspended the gasoline automobile motor from the upper beam of the triangle by piano wires. Here the compact little engine of 4 cylinders and 16 horsepower hangs like a spider in the center of her web. Over each cylinder spins a ventilating fan to prevent overheating. The motor turns a shaft, and attached to the shaft is a propeller, exactly like the screw of a ship. The two wings of the screw are of silk stretched over their frames like the head of a drum. They measure  $4\frac{1}{2}$  yards. Ordinarily the industrious little motor spins the shaft around at the rate of 200 revolutions to the minute; but since putting things into shape after his descent of July 13 the inventor has been able to increase the speed to 210 revolutions a minute. The whirling pinions then have a striking force of 175 pounds. Above the propeller and under the tail of the balloon is the rudder, a curved triangular blade made in the same way as the wings. As both propeller and rudder are thus placed at the stern, the forward end is left free for the guide rope, by which the air ship may be inclined upward or downward. By this device the aeronaut may ascend or descend. In his former balloons he used sliding ballast bags at either end to maintain his equilibrium, but in this last balloon he has been able to discard these.

To readjust the balance against the motor, as well as to equalize the strain on the wires suspending the framework, the basket is placed forward of the center by nearly 8 yards. This basket is a deep, narrow affair of open willow work. A larger man than the wiry aeronaut would have to squeeze to climb into it. On either side a narrow wooden bar stretches out 3 or 4 yards, which is designed to prevent undue tipping to one side or the other. As the pilot stands there in his basket he resembles a performer on a tight rope with his balancing pole. Since the head of the concern is in the basket, all the many wires that operate one thing or another communicate with this central administrative bureau like the nerves with the brain. On the front edge of the basket is a wheel, really the pilot's wheel, but placed horizontally as on an automobile. This operates the rudder. To switch



OFFICIAL TRIAL, JULY 13. PHOTOGRAPHED FROM  
THE EIFFEL TOWER.

"Steadily it neared the shadowy obelisk line which  
was Eiffel Tower."



OFFICIAL TRIAL, JULY 13. RETURN TO PARK AT 7.20 A. M. PHOTO-  
GRAPH TAKEN FROM DIRECTLY BENEATH.

"There he was, steering far above the river."



the propeller shaft from the motor and stop the fans there is an electric key. For each of the valves in the belly of the balloon there is a wire end at the basket, besides still another one for the big valve in the top should the balloonist wish to descend rapidly, and, yet again, there is an emergency cord which tears a panel out of the silk and lets the gas fairly pour out. It was this cord that Santos-Dumont pulled when he chose the Rothschild chestnut trees between the Seine and the streets of Boulogne. As to ballast, he has small bags of sand under his feet and a canvas bag on either hand, about 100 pounds in all. Thus, it will be seen that he has several things to think about at the same time. Though seemingly very complicated, this air ship that really navigates the air is, after all, a simple machine, and by the side of the wonderfully made air ships that yet do not navigate the air it is a child's toy for simplicity. It is one-fourth as large as the Zeppelin balloon. In fact, it is the smallest motor aerostat that has been constructed up to date. The entire car complete weighs but 550 pounds.

#### SOME ACCOUNT OF THE INVENTOR.

To arrive at this result, which is conceded to be the first actual steerable air ship, Santos-Dumont has tinkered away some five preceding balloons. He came to Paris expressly to make his career in the air. He bade farewell to the plantation of his father, the Brazilian coffee king, where as a boy he had speeded locomotives, real compounds, over the premises. He abandoned these toys and took up with what the French love to call the most French of inventions, flying machines. He allied himself with those rich young Parisians who seek amusements more chic than gilded dissipation; that is, the more intellectual, though scarcely more rational, pursuit of bizarre methods of locomotion. Though able to have stables, and yachts, and palace cars, they prefer automobiles and balloons. The youthful Alberto began by climbing Mount Blanc to see what high altitudes were like. Then, in 1898, he ordered himself a balloon and called it the *Brésil*. It was a ludicrously small affair, of not more than 145 cubic yards. He would return from a trip with the balloon in his grip. But he was not content. The *Brazil* was spherical, unsteerable—in a word, old fashioned. He put the motor of his automobile into the basket, and was thus the first to apply gasoline to aerial navigation. But as yet the results were not important. That same fall he launched the *Santos-Dumont I*, the first of his cigar-shaped experiments. But the weight of the basket 10 yards beneath made the balloon cave downward, and air ship and man tumbled 500 yards to earth without getting hurt—a mere incident. Next year appeared the second *Santos-Dumont*, of the same form, but a little longer. He went up Ascension Day, became dissatisfied, and began work on his No. 3. This one was 22 yards long, with a capacity

of 650 cubic yards. The motor worked well, and he made several encouraging ascensions near Eiffel Tower.

Last year, with his No. 4, he had tried for the Deutsch prize, but was awarded only the annual interest of about \$760 on the principal amount for having done the most for aerostation during the year. He promptly returned the money and founded a new prize with it, to be awarded for the first trip around Eiffel Tower, no time limit. He had the foresight to bar himself from this competition. The *Santos-Dumont IV* had a capacity of 546 cubic yards, with a 9-horsepower, 2-cylinder motor giving 100 revolutions a minute to the screw. The engine and a bicycle saddle were perched on a bar suspended under the balloon. He started the engine by working the pedals under the saddle, and by cords he controlled the electric lighting of the motor and the management of the rudder, ballast, and equilibrium. He made almost daily flights with this balloon, then later on put in a 16-horsepower engine. This, of course, made a larger gas bag necessary, but he simply cut in half the one he had and lengthened it to 36 yards, as you would a dining-room table. Soon after this the autumn air gave him pneumonia, and he had to go to the Riviera, where he began work on No. 5, his latest pet.

#### THE SECRET OF THE SUCCESS OF THIS LATEST AIR SHIP.

Now that you have followed the inventor through the whole story, you are beginning to demand where, after all, is the great monumental and mysterious secret of aerial navigation that has been discovered. You have not stumbled upon the trace of one. There has not been a single new mechanical principle involved. The fact is, there has been no secret to discover. The secret of aerial navigation was already discovered when the first automobile with a gasoline motor was built. When Santos-Dumont robbed his automobile of its motor and strapped it into the car of his balloon, he was on the right track. But he certainly had achieved nothing that he could patent. The secret may also have been discovered when the steam engine was invented, or again when electricity was chained down to man's service, only up to the present there is this fact, namely, no one so far has been able to make a steam engine or an electric battery run an air ship. That may happen later, but meantime the gasoline motor does the work for Santos-Dumont. And now the question is, Why does it, rather than either steam or electricity? The entire answer lies in this one word—"weight."

When away back in 1783 the crinoline skirt of Madame de Montgolfier, drying before the fireplace, filled with hot air and puffed up to the ceiling, this same word, "weight," became the keynote of battle and the problem in ballooning. Joseph Montgolfier had beheld the antics of his wife's skirt, and the word that involves the riddle

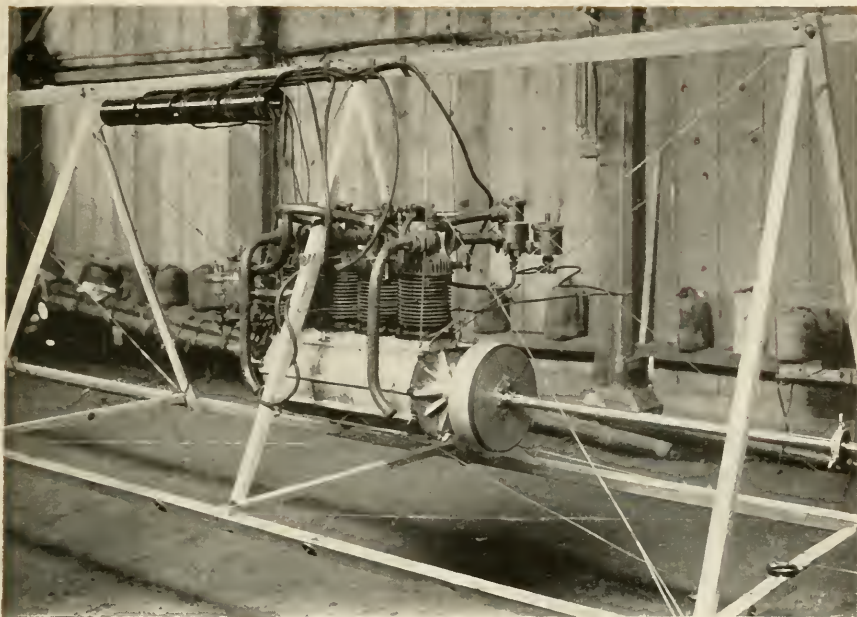

SIXTEEN-HORSEPOWER PETROLEUM MOTOR OF SANTOS-DUMONT V, GIVING SCREW 200 REVOLUTIONS PER MINUTE.



M. SANTOS-DUMONT'S QUARTERS ARE MORE COMMODIOUS ON EARTH THAN IN THE AIR.





and the solution spelled itself on his brain. That is, he reflected that the inflated crinoline had become lighter than air. So he set to work and astounded the world with the first balloon, an humble paper globe filled with hot air that soared upward but a few yards. Thus having once got into the air, man has ever since been trying and trying to steer himself while there. But any motor that would be powerful enough has always made the balloon heavier than air. For instance, Henri Giffard in 1852 tried steam as motive power, and he was the first to adopt the cigar-shaped bag, but his engine would not propel the balloon, simply because it had to be too light for the power exacted of it. Twenty-five years later Dupuy de Lome went back to first principles and tried manpower, but the man was even less adequate than Giffard's feeble engine. In 1883 another Frenchman, Tissandier, experimented with electricity, but as his batteries had to be light enough to be taken up in the balloon, they proved effective only in helping to weigh it down to earth again. Krebs and Renard, military aeronauts, succeeded better with electricity, for they could make a small circuit with their airship, provided only that no air was stirring. Enthusiasts cried out that the problem was solved, but the two aeronauts themselves, as good mathematicians, figured out that they would have to have a motor eight times more powerful than their own, and that without any increase in weight, which was an impossibility at that time.

Shortly after this, though, people began to drive round in carriages without horses, and their motive power was the gasoline engine. Tissandier's electro motor weighed 375 pounds per horsepower; Santos-Dumont's petroleum motor, 12 pounds per horsepower. In both cases fuel and all accessories are included. Now, just exactly in this enormous difference of weight lies the secret of aerial navigation as solved the other day by the young Brazilian.

The explanation why the petroleum motor is such a tremendous giant for its size is very simple. The greater part of its fuel is in the air itself, and the air is all around the balloon, all ready for use. The aeronaut does not have to take it up with him. If he did, he would be crushed to earth with the weight of his reservoir. But that proportion of his fuel that he must carry, the coal-oil can, is comparatively insignificant. The difference between carrying this fraction and carrying all the fuel, as for steam or electricity, makes the difference between the newer kind of motor and the two old kinds. A few figures will prove startling. Two and one-half gallons of gasoline, weighing 15 pounds, will make a  $2\frac{1}{2}$  horsepower autocycle cover 94 miles in four hours. Santos-Dumont's balloon needs less than  $5\frac{1}{2}$  gallons for a three hours' trip. It weighs but 37 pounds, and occupies the slender cigar-shaped brass reservoir which you will notice near the motor. Now, then, an electric battery of the same power would

weigh 2,695 pounds, and yet would last only twenty-five minutes. If we consider the weight and volume of fuel in the air which the gasoline motor does not have to carry up, we will see, on accepting chemistry's word, that a liter of gasoline ( $3\frac{1}{2}$  pints) consumes during combustion 5.45 pounds of oxygen in the air, which means  $27\frac{1}{4}$  pounds of air. Imagine, therefore, a balloon carrying a reservoir of air for its motor. One liter of gasoline would require an air magazine a yard square and as high as a four-story house. For Santos-Dumont's oil can this magazine would have to be 1,000 feet high, or about big enough to hold the Statue of Liberty.

As to what this last air ship really means for aerostation, French opinion differs to the overheating point. Again "weight" is the battle cry raised in the two opposing camps of balloony. One camp maintains that the balloon lighter than air is the beginning and end of the question, and consequently they hold that Santos-Dumont has found the ultimate solution, because he can steer his inflated chariot. Their opponents give the Brazilian big credit for making a dirigible flying machine of any kind, but they contend that the problem rests unsolved so long as the air ship is not heavier than air. The discussion has grown quite ardent. There are liable to be some duels most any time if cold weather does not set in.

The lighter-than-air people argue that on an aeronef or aeroplane (heavier-than-air machine) the operator would be at the mercy of his motor. If the motor stopped, the air ship would come down like a clod, having, of course, no gas bag to hold it up. The heavier-than-air contingent admit that this is a point to be considered, and that, therefore, the motor will have to be a very reliable motor indeed. And then they proceed to point out that the aerostat (lighter-than-air machine) can never be of any practical use anyhow, even if you can steer it. For war purposes it offers too large a target for the enemy. The risk of a motor stopping on a small aeroplane would be much healthier. For private promenading it would be too costly. And as for general transportation—not to be considered at all. The *Santos-Dumont V* requires 550 cubic meters of gas for one little man of 120 pounds, and even then the little man can not take on more luggage than his life and his nerve, with a fair chance of losing both before he gets back. Therefore a balloon with the passenger list of a small trans-Atlantic steamer would have to be some twenty times larger than Barnum's biggest tent, and the balloon house would cover a fair-sized city. Only the traveler with a million to spare could book a passage thereon, and all the other millionaires would go bankrupt financiering such an enterprise. The gentlest breeze would prove a tempest for the fabulously stupendous gas bag, and the pressure under ordinary conditions would make a metal covering absolutely necessary. On the other hand, the aeroplane—when found—may be of a size more in



LANDING OF THE BALLOON AMONG THE TREES IN THE GARDEN  
OF BARON EDMUND DE ROTHSCHILD, JULY 13.

"The delicate skeleton framework was unhurt, except for a slight  
spraining of the propeller shaft."



proportion to the carriers on sea and land, and by inclinations of its surface it need not fear a gale much more than does a ship.

In conclusion it seems that the *Santos-Dumont V* may be correctly rated as the last evolution from Madame de Montgolfier's crinoline skirt. It is the culmination of balloons lighter than air. It is the first to make a trip in a breeze and come back to a point indicated beforehand. In a word, it is steerable. Of course there remains room for improvement, but hardly for further evolution. In aeronautics all evolution from now on must begin from the bird and end in the aeroplane. And perhaps that will involve a new principle of mechanics. The genius who discovers it will be a colossus, beside whom the clever and daring craftsman who applied an automobile motor to an inflated spindle will be but the merest pigmy. The aeroplane, though, has not left the ground yet. But the *Santos-Dumont V* has. The neighbors have already made complaint. They protest against the early morning flights, when the popping of the motor a few yards over their roofs breaks in on their slumber. There you have a foretaste of the future.

---

SANTOS-DUMONT WINS THE DEUTSCH PRIZE.<sup>a</sup>

Now that the efforts of Santos-Dumont have been crowned with success, it may be of interest to retrace the steps by which the intrepid young aeronaut has been able to accomplish his present great triumph, which is, of course, only the first step in the work which he expects to carry out. Santos-Dumont is a Brazilian by birth, and was born in 1873. His father, who was of French descent, had a vast coffee plantation which employed as many as 6,000 men in the fields and establishments. It was upon the 40 miles of railroad which passed around the plantation that Santos-Dumont learned to conduct the small locomotives, and thus obtained his first knowledge of mechanics. He came to Paris while still quite young, and had already turned his attention to aeronautics. He at once commenced to work, and employed his large fortune and his talent in this direction. The result is that within three years he has constructed three spherical balloons and six air ships. He began by making the record for the smallest spherical balloon, the "Brésil," which gauged only 140 cubic yards and had a diameter of 18 feet. It was made of fine Japan silk with cotton cordage and an extremely light wicker basket, and the whole weighed but 50 pounds. When it rose from the Jardin d'Acclimatation on the 4th of July, 1898, it seemed like an immense air bubble. After ascending out of sight, Santos-Dumont reappeared with the envelope packed in the basket. With this and

<sup>a</sup>Reprinted by permission from the Scientific American, November 16, 1901.

similar balloons he made a number of interesting ascensions, but soon began the study of dirigible balloons. His "No. 1" is the first of the series, and started from the Jardin d'Acclimatation on the 18th of September, 1898. It was torn at the start on account of a false maneuver by the aids, but was soon repaired, and on the 20th he made a number of evolutions. But the small interior air balloon, designed to keep the envelope always swelled out, was only insufficiently supplied by the ventilator, and thus the balloon, which was cigar-shaped, became more or less collapsed and folded upon itself under the tension of the weight. On this occasion the aeronaut had a fall of 1,200 feet at the rate of 12 or 15 feet a second, which, as M. Emmanuel Aimé says, is a record in itself. He came down on the Bagatelle training ground, however, without damage.

The *Santos-Dumont No. 2* was launched on the 11th of May, 1899, but during a rainstorm the balloon folded upon itself and could not be further maneuvered. An instructive test of the motor (gasoline type) and the helice was, however, made on this occasion. With this experience to guide him, he next built the "No. 3." It gauged 620 cubic yards, and was the first of the series to pass around the Eiffel Tower, starting from the Aerostatic Park of Vaugirard on the 13th of November. The "No. 4" is an improvement of this type, and gauged 525 cubic yards. It was finished on the 1st of August, 1900. He went through a number of evolutions with this air ship, notably on the occasion of the Aeronautic Congress, on the 19th of September, at the Aerostatic Park of the Aero Club. At the beginning of this year he finished the *Santos-Dumont No. 5*, which made such a brilliant performance. It will be remembered that he started from the Aerostatic Park, crossed the Seine to the Longchamps race track, and then took the air ship ten times around the track. He then came to the Trocadero, and after an accident to the rudder he started again, went around the Eiffel Tower, came back to Longchamps, and thence recrossed the Seine to the Aerostatic Park.

It was the Henri Deutsch prize that made the tower the goal of the aeronauts, as the conditions of the prize of \$20,000 were that the start should be made from the park or vicinity, the aeronaut to pass around the tower and return to the starting point within half an hour. Accordingly, Santos-Dumont, the day after the above experiments, started from the park and passed the tower, coming back in forty minutes. But owing to a strong wind and an accident to the motor he could not land in the park, but came down in the trees of M. de Rothschild's garden. It was after this that he had his famous accident, where, after passing around the tower (8th of August) the motor stopped and the balloon was broken almost to pieces against the roofs of the Trocadero Hotel. Only twenty-two days after this catastrophe

the aeronaut, whose courage is proverbial, finished his "No. 6," with which he at last succeeded (October 19) in passing around the Eiffel Tower and returning within the half hour, or twenty-nine minutes and thirty seconds. Some time before this, however, the committee of the Aero Club had modified the original rules so that the air ship was not only to come over the park, but its guide rope should be grasped by an attendant, this constituting a landing. Santos-Dumont was not able to comply with this rule, as before the rope could be grasped he was obliged to remount to avoid being carried by the wind against the balloon shed, and he came down forty seconds after the allotted time.

The committee decided on November 4 as to this much disputed question, and Santos-Dumont was accorded the prize.

M. SANTOS-DUMONT WINS THE DEUTSCH PRIZE.<sup>a</sup>

The committee in charge of the distribution of the Deutsch prize decided on November 4 that M. Santos-Dumont was entitled to it by his achievement of October 19. At eighteen minutes to 3 o'clock he

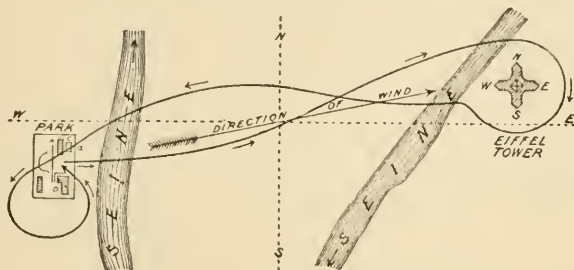

made the start, and in nine minutes the *Santos-Dumont No. 6* had reached the Eiffel Tower on the north side, made a complete turn around it and made for the starting point. Our diagram gives an idea of the course which was followed. At 3:12:40 the guide rope was seized, and, according to the rules which were recently formulated by the committee, M. Santos-Dumont had lost by forty seconds. He claimed, however, that he had begun his experiments under conditions in which the guide rope did not figure, and he at once protested against the decision of the judges. The matter was left to a committee, which decided in favor of M. Santos-Dumont on November 5.

He donated 50,000 francs, or one-half of the sum, to the poor of Paris. He then gave 30,000 francs to his assistant, M. Aimé, and the remaining 20,000 francs to the aeronaut's other collaborators.

While M. Santos-Dumont has performed a notable feat, it does not necessarily follow that he has accomplished anything of very great

<sup>a</sup> Reprinted by permission from Scientific American Supplement, November 16, 1901

value. He has demonstrated the fact that with a very costly and delicate apparatus a skillful aeronaut may, under favorable conditions of wind and weather, rise from a given point, make a circle and return to the spot from which he started without being killed, if he has good luck. The event, pleasant as it is, does not, however, mark a step in the direction of the practical realization of aerial navigation. It is probable that the solution of the problem of aerial flight will never be reached in a way which will have any commercial value until the dirigible balloon idea is abandoned and that of a mechanism built on a strictly mechanical basis substituted.



## AUTOMOBILE RACES.

---

### I.—THE AUTOMOBILE.<sup>a</sup>

By HENRI FOURNIER.

Undoubtedly the automobile has come to stay and to do, as the years go on, more and more of the world's work.

The fact that I went a mile in  $51\frac{1}{2}$  seconds on the Coney Island boulevard the other day shows the swiftness we have already attained with these machines, and it must be remembered that they are as yet only in their infancy. Six years ago we were making very bad automobiles in France and Germany—almost as bad as those the American makers are now turning out. Now France and Germany make fine autos, and I have come to this country to make fine autos here.

We French are manufacturing better automobiles than the Americans because we began first and because our conditions are more favorable for development. Coney Island boulevard is as good as any road in France, but in France they have thousands of miles like it, while here there are very few.

Of course, our good roads helped the automobile, as also did our comparatively bad railroads. Here, on the other hand, there are good railroads stretching everywhere through a brand new country, where the wagon ways are still rough.

The conditions for automobile development are therefore not so favorable here as in France. But they are improving very rapidly.

Not so with American-made automobiles. I do not see any improvement in them since I was here three years ago. The machine in which I made the mile record of  $51\frac{1}{2}$  seconds was of French make, as also was that in which Mr. Foxhall Keene did a mile in  $54\frac{3}{8}$  seconds.

The makers here started wrong. Instead of taking the best French and German models and trying to improve on them, they set out to produce something original, and thus went over all the ground previously traversed by European manufacturers, and fell into the errors out of which the latter had laboriously struggled. It is a shame, for their trouble and expense were quite unnecessary. They should have

---

<sup>a</sup>Reprinted, by permission, from *The Independent*, New York, Vol. LIII, Dec. 12, 1901.

taken advantage of the experiments and experiences of those who had preceded them.

The greatest change which I believe will be made in your cities by the perfect automobile will be in the wagon service. The old horse and wagon and horse and cart will have to go; the automobile is so much better, quicker, surer, cheaper. This will make a great difference, as it will just about abolish all stables throughout the city, and by clearing horses off the streets will at once render them much cleaner. It will also make imperative the extension of smooth paving like the asphalt, which in certain weather is unfavorable for horses, but always good for the automobiles.

In addition to this the new machines will greatly increase the wagon capacity of city streets, because they are so much shorter than a horse and wagon, and travel so much more swiftly. With the horse banished and complete auto service throughout the city the capacity of the streets would be at least quadrupled, which would do away with the blockades that now are so frequent on some of the narrow water front streets.

Then, of course, for conveyance to and from business and for coaching and pleasure riding the automobile is far superior to the old carriage, coach, or cab. It is not necessary that anyone should travel at the rate of 70 miles an hour. He need not race unless he so desires and the time and place are proper for racing. Twenty miles an hour is a good pace, although safer with the automobile than going 8 miles an hour behind a horse. And it is delightful to travel in an automobile going 20 miles an hour. The sensation is most exhilarating—like that of flying, as I imagine—and there are no ill effects.

Twenty miles an hour behind an automobile is safer than 8 miles behind a horse, because the auto is so very much shorter, so powerful, and so easily controlled. I can teach anyone to manage an automobile in half an hour, and though it is going at high speed, one can stop the machine on its own length. Anybody can manage it, and it turns, twists, and dodges about so easily that accidents are avoided which would be disastrous if you were sitting behind a horse. During all the time that I have been driving these machines I have only had one accident. That was the collision with the train of the Long Island Railroad Company which occurred several weeks ago. I have never yet been hurt, though constantly racing, which, I think, goes to show that there is comparatively little hazard about running an auto.

For conveyance of people on short journeys or pleasure jaunts the automobile in this country has a great mission to fulfill, and this will be constantly extended as the good roads which the machines demand are given.

Some people anticipate that the automobile will drive out the electric car and so rid our streets of the tracks and the overhead wires.



HENRI FOURNIER.

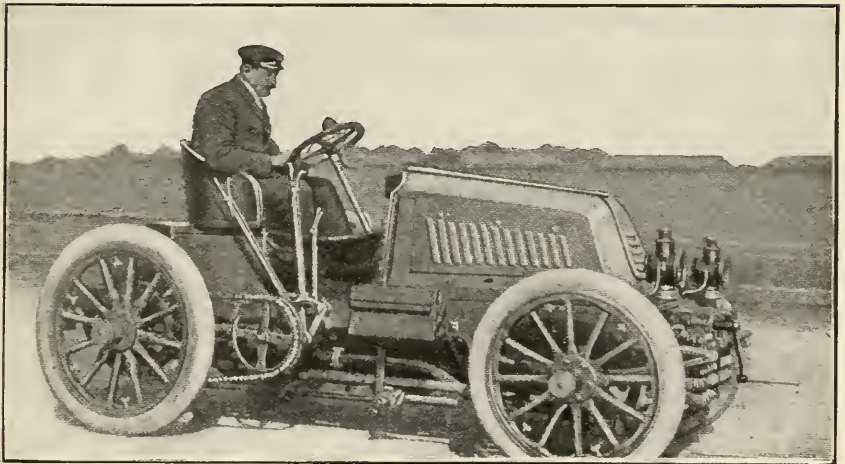

HENRI FOURNIER AND HIS RACING AUTOMOBILE.



I, however, am not among those who believe that that will be done—at least not soon.

An automobile service carrying passengers throughout the city for 5 cents would have many advantages. The vehicles, not being limited to tracks, could not be blocked as they now are, and an accident to one of the 5,000 or 6,000 which would be necessary to the service would have no effect upon the others.

However, the automobile surface car to take the place of the trolley is still so far in the future that it can safely be left for future discussion.

In war the auto would not cut much of a figure so far as this country is concerned, though it might be of considerable service in Europe, where they have such perfect roads. America's lack of military highways would place the machine at great disadvantage as compared with a horse.

There has been some suggestion of field guns carried about by automobiles, but I feel sure that they would not do at all. Field guns have to go through very rough places, plowed fields, for instance, and they need a pull from the front, such as the horse gives, in order to get them along.

The power of the automobile is applied directly to the wheels and does not pull the machine at all. Thus, in a plowed field the wheels would revolve quickly enough, but they would only make a hole in the ground, while the machine stood still.

This same reason would also prevent the auto from doing much for the farmer.

On the other hand, in countries like France and Germany, where there are many good roads, I believe that the automobile could be of the greatest service for moving ammunition and provisions, as well as for carrying scouts, dispatch bearers, or generals, or even the conveyance of troops.

## II.—NEW AUTOMOBILE SPEED RECORDS.<sup>a</sup>

Twenty-five thousand persons lined Ocean Parkway, Brooklyn, for a distance of  $2\frac{1}{2}$  miles on Saturday, November 16, 1901, and saw the most sensational automobile 1-mile speed tests ever made on either side of the Atlantic. A mile a minute on the highway is no longer an automobile dream; for no less than three of the contestants finished within that time. Fournier, the winner of the Paris-Berlin race, twice broke the world's record, and was closely followed by Foxhall P. Keene, A. C. Bostwick, and A. L. Riker. The course was a specially prepared dirt strip of the old Coney Island Boulevard, having a slight down grade. The contestants went over the course singly, their time being taken at the start and at the finish by members of the Second

<sup>a</sup> Reprinted, by permission, from the Scientific American, November 30, 1901.

Signal Corps, U. S. A. Over a mile was allowed to the chauffeurs to get under way, and about a quarter of a mile to slow up after passing the finish line. The race was a contest by some of the best chauffeurs in the world for the 1-mile record.

At his first attempt Fournier, in his 40-horsepower Mors racer, sped over the mile in the remarkable time of fifty-two seconds. Not content with this performance, he returned to the start for another trial, and succeeded in reducing the record made but a few minutes before by one-fifth of a second. Foxhall P. Keene, in a Mors carriage exactly similar to that of Fournier, covered the mile in fifty-four seconds. American-built vehicles were not much behindhand. A. C. Bostwick, in a 40-horsepower Winton gasoline carriage, made the mile in fifty-six and two-fifths seconds at the first trial, and in one minute three-fifths seconds at the second trial.

Good as the road undoubtedly was, it was not altogether free from slight, almost unnoticeable depressions and projections. At a speed of 20 miles or even 30 miles an hour an automobile will ride over a slight elevation with no appreciable effect. But at the enormous velocity of nearly 70 miles an hour the carriages could not yield to the slight, scarcely perceptible hollows, and at times every wheel would be clear of the road. And yet, despite this peculiar effect, they kept their course with remarkable precision and with no evident oscillation.

The vehicles driven by Fournier and Keene were both 40-horsepower French gasoline carriages made by Mors. That a gasoline carriage would make the best record was inevitable. But no one foresaw that an electric car would also lower the previous world's record of one minute six and two-fifths seconds made by Winton. The carriage in question was designed and driven by Mr. A. L. Riker, and was a distinctly American type of machine. It was a racing machine pure and simple, an electromobile reduced to its lowest terms, a wheeled frame and a battery, with seats for two men arranged in tandem. Current is derived from 60 cells of the lead-zinc type, giving a maximum voltage of 130 and a discharge of 100 amperes. The battery weighs 900 pounds, and the entire carriage 1,850 pounds. With a start of only one-quarter of a mile Mr. Riker covered the mile in one minute and three seconds, the armatures of his motors making about 3,300 revolutions per minute. The exact power of the vehicle has not been determined, but Mr. Riker informs us that the horsepower is between 15 and 20. When it is considered that the French carriages of Fournier and Keene were equipped with motors rated at 40 horsepower, Mr. Riker's performance is all the more remarkable. At the same time, it is but just to the other vehicles to state that while they were all capable of long-distance touring, the electric machine was capable of maintaining its maximum effort apparently for only a single dash



RIKER ELECTRIC RACING AUTOMOBILE WHICH MADE THE RECORD OF 1 MILE IN 63 SECONDS ON SATURDAY,  
NOVEMBER 16, 1901.





over the mile course. It was towed to the course, towed back to the starting point after the trial, and charged its batteries immediately before its trial run from an adjoining electric car. By a special rheostat, with which he has fitted his racing machine, Mr. Riker is enabled to divert part of the current from the field coils to the armature, after speeding up, so that the rotary speed of the armature shaft is considerably increased. Since the racing machines of Fournier and Keene have already been illustrated in these columns, we have pictured only the carriage used by Mr. Riker.

The arrangements for timing the contestants seem to have been somewhat unusual. The timers at the finish were informed by the click of a telegraph instrument that a machine had started. An instant later an "O. K." signal was given to confirm the start. The timers consequently started their watches with the first click and caught the machines as they whirled past the finish line. If no "O. K." signal was given, the watches were turned back for the next signal. As a result of this arrangement some machines ran over the course without being timed, no additional signal having been given. Foxhall P. Keene was one of those who suffered. His first trial was credited with a speed of one minute and twenty-one and two-fifths seconds, which was clearly an error. S. T. Davis, who made the mile in one minute and fifteen seconds in a steam carriage, and thus broke the previous steam carriage record of one minute and thirty-nine seconds, was also mistimed in one of his attempts.

These are the most remarkable contests ever run on a public highway. They have shown that only a specially built locomotive engine running on steel rails can beat a modern racing automobile.

### III.—THE PARIS-BORDEAUX RACE.<sup>a</sup>

The classic race between Paris and Bordeaux is practically a history of progress in the automobile industry, since it is in this great event that we are able to see the new developments in motors and carriages, and the rivalry of new firms who take advantage of this exceptional opportunity to prove what their vehicles are capable of doing. Nothing is more eloquent of the marvelous advance of the industry than a comparison between the race of 1895, when Levassor astonished the world by driving a 4-horsepower car between Paris and the capital of the Gironde in a little more than twenty-two hours, and the race on Wednesday of last week, when a 20-horsepower Mors reduced this time to six hours, and covered the 327½ miles at the average speed of 53.3 miles an hour. Six years ago the racing car was fitted with a motor of 6 horsepower, but last week there were several vehicles of 28 nominal horsepower, while in one or two cases they were said to

<sup>a</sup> Reprinted from the Autocar, London and Coventry, England, Vol. VI, No. 293, June 8, 1901.

have 60 or 70 horsepower. We say that these powers are nominal, because they merely represent a type of carriage, and are by no means the actual power developed. Makers are rarely disposed to take the public into their confidence over the details of these special racing machines. The indicated power of the vehicles is kept a secret, but it may safely be said that a car entered as 24 horsepower is capable of giving considerably more. Even accepting the figures stated, the increasing of the motive power fourfold in five years is a remarkable achievement, the more so as the weight of the cars has not even been doubled in the same period. Whether this rate of progress can be continued much further is a question that can only be solved by the forthcoming races. The competitions have already shown makers how to get the best out of their motors, and it is at a moment when they are anxious to settle an interesting problem in weight and speed that an attempt has been made in some quarters to suppress racing altogether. The success of the Paris-Bordeaux event has evidently brought these people round to see the error of their ways, for the newspapers which have been the most uncompromising in their anti-racing crusade are actually admitting that if proper precautions are taken, a race, after all, may be both interesting and instructive.

#### THE GORDON-BENNETT CUP.

To a certain extent it may be said that the open race was merely intended to be a pendant to the Gordon-Bennett cup competition, but as it turned out the cup had to pale its ineffectual fires before the open race. If the cup competition had been run off separately, as was the case last year, it would have been an utter fiasco. At first it seemed as if this international triangular match were going to be one of the biggest events of the year. Both England and Germany had entered vehicles, and after the brilliant performances of the Mercedes cars at Nice there was every promise of the competition with the new French fliers proving of absorbing interest. But unfortunately the owners of the Mercedes vehicles withdrew on the ground that the Automobile Club of Germany made their selection too late to enable the cars to be ready in time, and neither Benz nor Canello-Dürkopp would take their place. At the last moment Tischbein entered a vehicle, which, however, could not be got off in time for the race; and then Mr. W. K. Thorn, president of the Automobile Club Bearnais, offered to place his Mercedes at the disposal of Tischbein if the French carriage body could be replaced by one of German manufacture. They went all over Paris in search of this body, but no carriage builder had one on hand. Then among the English Napiers, the Hon. C. S. Rolls and Count Zbrowski declared forfeit, and the only one to turn up was Mr. S. F. Edge. The English representative drove his car from Bologne to Paris, and had so much trouble with his Eng-

lish tires that he saw it was useless trying to go to Bordeaux unless he could get fresh ones. As this was not possible in the time, he replaced them with French tires, which, of course, disqualified him for the cup competition, and he decided upon starting in the open race. As the Napier arrived at the premises of the Automobile Club, where it had to undergo the process of marking, it attracted a vast amount of attention, and there is no doubt that it created a strong impression among the Frenchmen by its powerful lines. It looked heavier and bigger than the French vehicles, partly due to the fact that it has not such a low center of gravity as the new cars. If, as was stated, the Napier developed 70 or 75 horsepower, it was by far the most powerful of the competing vehicles, for though the new Mors was at first said to be fitted with engines of this force, it was entered as 28 horsepower, and it may therefore be supposed to give something like 35 horsepower. All the foreign competitors having scratched, the cup race became a run over for the French vehicles, but even then things did not go smoothly, as there was trouble between Charron and Girardot and the makers whose vehicles they were to drive. Fortunately, matters were satisfactorily arranged, and Charron and Girardot, on their new 24 horsepower Panhards, and Levegh, on his 28-horsepower Mors, turned up at the start.

#### THE FÊTE DE NUIT.

The vehicles were to be sent off at 3.30 in the morning, and to pass away the still small hours a fête was organized at the Chalets du Cycle in the Bois de Boulogne, where all the automobilists who had not gone down to Bordeaux were present. And then there was a nocturnal procession up the Suresnes hill to St. Cloud. The sight was an extremely picturesque one, as hundreds of cyclists with their colored lanterns kept prudently to the side of the road, while the big cars flashed their headlights up the hill. On arriving at the starting place beyond St. Cloud, we found the road to Versailles in possession of the gendarmes, and a squadron of cavalry guarded the approaches, though why they were there is a mystery that is yet unsolved. The auto cars lined up on each side of the road according to their numbers, and photographers flashed magnesium light to get views of the competing vehicles. Still another light leaped out of the darkness through one of the spectators coming to the assistance of Fournier with a match while he was filling up the petrol tank. The spirit caught fire, and it was only by Fournier's presence of mind that the flame was prevented from reaching the tank. The gendarmes were busy seeing if the papers of the competitors were in order. The officials had a lively time of it during this operation. Some of the chauffeurs, including Levegh and Gilles Hourgières, had not brought their certificates, and the police insisted that they should not start, but as the result of an interview with the prefect the objection was overruled, though two competitors had to turn discon-

solately homeward. A lot of time was wasted over these formalities, and it was not until 4 o'clock that the start was given to the cup vehicles. Charron was sent off first amid cheers, but he had not gone many yards up the first hill when he stopped and hurriedly arranged something, and then resumed his journey. Two minutes afterwards the word was given to the favorite, Levegh, who simply flew up the hill with his powerful Mors car, and after a similar interval Girardot was sent off and made an equally favorable impression by the way in which he tackled the gradient. The departure of the cup triumvirate was followed by an interval of eleven minutes. At 4.15 S. F. Edge, the first competitor in the open race, received the word, and the Napier car jumped forward and climbed the hill at a speed which considerably opened the eyes of the public. The others were sent off every two minutes. Giraud on his light Panhard carriage, Voigt on a 24-horsepower Panhard, André Axt on a 20-horsepower Panhard, Gilles Hourgières on one of the new 28-horsepower Mors, Fournier on a 20-horsepower Mors, De Caters also on a Mors, were started in that order, and then followed the other big cars, light carriages, voiturettes, and motor cycles in the order of entry, the total number sent off being 63.

#### THE RACE.

As at all the towns along the route, Versailles was neutralized; that is to say, the vehicles were not allowed to exceed the legal limit of speed, and they were given a quarter of an hour to pass through the town, this, of course, being deducted from the total time. Levegh had already passed Charron, who began to have trouble with his valves, and just outside Versailles he stopped about twenty minutes to adjust them. On leaving the town, the competitors were started at the bottom of a very steep hill, which was naturally not to the liking of the motor cyclists with their 8-horse power motors, as a sharp turning just here did not allow of their tackling the hill by getting up speed on the level. Baron de Turekheim on his De Dietrich got stuck on the hill, and one of the competitors in a light carriage began to experience the glorious uncertainty of pneumatic tires, while the motor cyclist Osmont met with a painful accident through a stone flying up and smashing his glasses, when a piece of glass entered his eye. This was removed and the eye bandaged, and he continued his journey. At Limours, Levegh was still leading two minutes ahead of Girardot, but Edge had been passed by Voigt and Giraud, and then followed Hourgières, Charron, and Fournier. The last-named improved his position up to Chartres, and got in front of Edge; while Charron was constantly stopping on account of his valves, and he again lost a lot of time on leaving the town. One of the light Hanzer carriages came to grief through the bursting of a tire, which caused the vehicle to turn right round and smash the two off side wheels, and the two occupants

were thrown out, but sustained no injury. Thiéry also had trouble with the valves of his Decauville motor. Altogether 55 vehicles passed through Chartres in the official time. On nearing Châteaurenault the little De Boisse three-wheeled vehicle ran into the gate of a level crossing which was closed, and was so far damaged as to compel the driver to give up the race. Levegh and Girardot were fighting out a grand battle, and the Panhard representative seemed to be gaining on the Mors vehicle up to Chateaudun—77 miles—but the most remarkable thing was the driving of Fournier, who was now leading in the open race, and was only three minutes behind Girardot. Voigt was close up, but he found it a disadvantage in having only three changes of speed, while the others had four. André Axt followed eighteen minutes afterwards, with Edge and Girardot at his heels. Charron was eighth, and Maurice Farman ninth. Edge lost his position through stopping fifteen minutes at Chateaudun. Another accident, due to a level crossing, occurred to a Godard-Demarest light carriage, which arrived just as the gate was closing, and in the collision the driver was thrown out with considerable force, and was so far injured that he had to be attended by a doctor. Girardot, who had been getting marvellous speed out of his Panhard, now began to have trouble with his friction clutch, and he reached Vendôme—102 miles—twenty minutes after Levegh, who arrived there at 6<sup>h</sup> 27<sup>m</sup>. Fournier was only three minutes behind Girardot, and then came Voigt, Gilles Hourgières, André Axt, Maurice Farman, Giraud, and Edge. Charron found that it was hopeless to continue when he had to stop every few miles to see to his valves, and he gave up the race. The first motor cyclist (Teste) reached Vendôme at 7<sup>h</sup> 34<sup>m</sup>. The weather was hot and heavy, and the roads thick with dust, which rose in dense clouds as the autocars sped along at 50 and 60 miles an hour. Levegh was going strongly, and reached Tours—137 miles—at 7<sup>h</sup> 19<sup>m</sup>. and Fournier, who arrived twenty minutes afterwards, had actually beaten him by three minutes. Voigt was third. Girardot stopped to fix up his friction clutch. He was already hopelessly out of it for the cup, and was philosophically letting the Mors vehicle increase its lead. After Girardot came Maurice Farman, André Axt, and Edge, and the motor cyclist Teste. Gilles Hourgières, who was expected to do great things with his new Mors, lost a lot of time through tire punctures. The situation of the leaders remained unchanged up to Saint Maure—159 miles—except that Edge had retreated to the rear and Girardot had fallen a long way behind, but a few miles farther on an accident happened to the Mors cup vehicle, which struck a gully across the road with so much force that the forepart of the car was smashed. It is supposed that the cause of this is the curved axle, which brings the motor case down to within a few inches of the road, and is very liable to be caught by an obstruction.

Fournier now went ahead, but when about a couple of hours afterwards Girardot, whose bad luck is proverbial, saw Levegh's Mors stranded by the wayside, fate for once in a way smiled upon him. Fournier reached Châtellerault at 8<sup>h</sup>. 37<sup>m</sup>., followed thirteen minutes afterwards by Voigt, while Maurice Farman was third, André Axt fourth, and Giraud fifth. Despite the sweltering heat, enormous crowds of people waited for hours along the route to see the autocars pass, and special precautions had to be taken to prevent spectators from crossing the road until the cloud of dust that rose up after the passage of each vehicle had cleared away. Couche-Verac—223 miles—was reached by Fournier at 9<sup>h</sup>. 58<sup>m</sup>., preceding Voigt by twenty-four minutes. Maurice Farman passed through at 10<sup>h</sup>. 45<sup>m</sup>., André Axt at 11<sup>h</sup>. 4<sup>m</sup>., and Giraud at 11<sup>h</sup>. 12<sup>m</sup>. Pinson, Teste, Girardot, Osmont, and Gleizes followed in that order, and then came S. F. Edge, who reached the town at 12<sup>h</sup>. 4<sup>m</sup>. Close at his heels was Gilles Hourgières, who had picked up Levegh and his companion. He was constantly puncturing his tires, and had given up all hopes of finishing in the first flight. There was no change in the positions of the leaders up to Ruffec—242 miles—which was reached by Fournier at 10<sup>h</sup>. 25<sup>m</sup>., half an hour in front of Voigt, and an interval of twenty-one minutes separated Voigt from Maurice Farman. The sun was hot and stifling as the first lot passed through Ruffec, but in the afternoon a violent thunderstorm burst over the district and thoroughly soaked those unfortunate competitors who were still behind. Many of them gave up the race from this cause. Voigt punctured a tire, and only arrived at Angoulême—269 miles—nine minutes in front of Maurice Farman, and Pinson also had a similar misfortune. S. F. Edge did not get to Angoulême until after 2 o'clock, and as he went through without stopping at the control he was obviously no longer racing. Up to Barbezieux—291 miles—Maurice Farman was able to pass Voigt for the second place, but Fournier was still increasing his lead, and got to Barbezieux forty-nine minutes before Farman. Fournier now had matters all his own way, and steadily augmented his advance, while Maurice Farman was improving his advantage on Voigt, who had up till now been going wonderfully well. On leaving Libourne, the motor cyclist Gleizes had a serious accident through trying to light a cigarette when traveling full speed. On letting go the handle bar, the machine went off at a tangent, and the unfortunate rider was badly knocked about. He remained unconscious for four hours. Interest in the race, which had been growing all along the course, culminated in enthusiasm at Bordeaux, where Fournier got a magnificent reception as he arrived at Pavillons at 1<sup>h</sup>. 9<sup>m</sup> 45<sup>s</sup> his net time for the full distance of 327½ miles being 6<sup>h</sup> 11<sup>m</sup> 44<sup>s</sup>, which is equal to an average of 53.3 miles an hour. Maurice Farman finished nearly an hour afterwards, followed after an interval of five minutes by Voigt. Then there was a pause of thirty-three

minutes until Axt completed his long journey in good style, and Giraud had a great success with the splendid performance of his light Panhard carriage. His average was 39.7 miles an hour. The only cup arrival, Girardot, finished eighth, his average being 37 miles an hour. The 4 Renault voitures ran with remarkable regularity, and finished close together, the winning car in this category, driven by M. L. Renault, making an average of 36.16 miles an hour. The De Dion-Bouton machines took the first five places in the motor cycle class, and the average speed of the winner (Teste) was 40.7 miles an hour. Altogether, 36 vehicles reached Bordeaux before the control was closed.

The results of the different categories are as follows: Gordon-Bennett cup race—Girardot, 24-horsepower Panhard, 8<sup>h</sup> 51<sup>m</sup> 59<sup>s</sup>. Paris-Bordeaux race—cars weighing more than 650 kilos: Henri Fournier, 20-horsepower Mors, 6<sup>h</sup> 11<sup>m</sup> 44<sup>s</sup>; Maurice Farman, 24-horsepower Panhard, 6<sup>h</sup> 41<sup>m</sup> 1<sup>s</sup>; Voigt, 24-horsepower Panhard, 7<sup>h</sup> 16<sup>m</sup> 11<sup>s</sup>; Pinson, 24-horsepower Panhard, 7<sup>h</sup> 46<sup>m</sup> 51<sup>s</sup>; André Axt, 20-horsepower Panhard, 7<sup>h</sup> 47<sup>m</sup> 17<sup>s</sup>; Gilles Hourgières, 28-horsepower Mors, 8<sup>h</sup> 37<sup>m</sup> 39<sup>s</sup>; Henry Farman, Panhard, 8<sup>h</sup> 53<sup>m</sup>; De Crawhez, Panhard, 8<sup>h</sup> 55<sup>m</sup> 34<sup>s</sup>; Berteaux, Panhard, 11<sup>h</sup> 10<sup>m</sup>; Léon Lefebvre, Bolide, 11<sup>h</sup> 53<sup>m</sup>. Light carriages of 400 to 650 kilos: Giraud, Panhard, 8<sup>h</sup> 9<sup>m</sup> 48<sup>s</sup>; Baras, 28-horsepower Darracq, 8<sup>h</sup> 42<sup>m</sup> 52<sup>s</sup>; Edmond, 28-horsepower Darracq, 10<sup>h</sup> 25<sup>m</sup>; Béconnais, Béconnais carriage, 10<sup>h</sup> 41<sup>m</sup> 25<sup>s</sup>; Théry, Decauville, 11<sup>h</sup> 11<sup>m</sup>; Sanz, Boyer, 11<sup>h</sup> 12<sup>m</sup>; Rudeaux, Darracq, 11<sup>h</sup> 49<sup>m</sup>; Ullman, Decauville, 12<sup>h</sup> 18<sup>m</sup>; Filtz, Turgan et Foy, 13<sup>h</sup> 57<sup>m</sup>; Chabrières, Decauville, 14<sup>h</sup> 5<sup>m</sup>. Voitures of 250 to 400 kilos: L. Renault, Renault Frères, 9<sup>h</sup> 32<sup>m</sup> 27<sup>s</sup>; M. Renault, Renault Frères, 9<sup>h</sup> 40<sup>m</sup> 14<sup>s</sup>; Oury, Renault Frères, 9<sup>h</sup> 46<sup>m</sup> 50<sup>s</sup>; Grüs, Renault Frères, 9<sup>h</sup> 52<sup>m</sup>; Lot, Liberia, 16<sup>h</sup> 4<sup>m</sup>. Motor cycles: Teste, De Dion, 8<sup>h</sup> 1<sup>m</sup>; Osmont, De Dion, 8<sup>h</sup> 3<sup>m</sup>; Bordeaux, De Dion, 8<sup>h</sup> 54<sup>m</sup>; Collignon, De Dion, 9<sup>h</sup> 11<sup>m</sup>; Bardin, De Dion, 10<sup>h</sup> 30<sup>m</sup>; Gasté, Liberator, 10<sup>h</sup> 32<sup>m</sup>; Holley, De Dion, 10<sup>h</sup> 33<sup>m</sup>; Cormier, De Dion, 11<sup>h</sup> 34<sup>m</sup>; Rivierre, Werner bicycle, 12<sup>h</sup> 30<sup>m</sup>; Buequet, Werner bicycle, 12<sup>h</sup> 47<sup>m</sup>.

#### THE FINISH OF THE CUP AND THE PARIS-BORDEAUX RACE.

On the off chance that an English car might start in, and the still more remote chance might win, the Gordon-Bennett cup race, we resolved to be represented at both ends of the course by members of our staff, and the writer, who journeyed as far afield as the finish, considers that a few words in supplement to the brief telegram last week may be of interest. We crossed on Whit-Monday in company with Mr. Worby-Beaumont, who could not deny himself the pleasure of witnessing the start, and after calling at the handsome quarters of the A. C. of France, and subsequently at the Hotel Brighton, where the majority of the A. C. G. B. party were staying, and where we found Mr. Mark Mayhew and the Hon. C. S. Rolls, we learned that the

French clubmen had shown most sporting feeling toward the English car, and had unofficially informed those most nearly interested that the car would be started, timed, and checked, although she would, so far as the race itself went, obviously be disqualified before she moved. The conditions of the race laid down definitely that every part of a competing vehicle must be built in the country by it represented, and the use of foreign tires of course crabbled the deal. The above arrangement was all that the English club or the owner or makers of the car could desire, and it was felt by the whole English party present that the French club had met them in their difficulties in a particularly handsome and generous manner. If the English car had won, well, the fact that she ran on Michelin tires would not have militated in the smallest degree against the renown and glory that would have been hers, and it is only by bearing this in mind that the sporting action of the Automobile Club of France can be thoroughly appreciated. Upon reaching Bordeaux we found Messrs. A. C. Harmsworth, Alfred Bird, and Max Pemberton, the well-known novelist, whose brilliant lately concluded story *Pro Patria* is still fresh in everyone's mind. These three gentlemen had driven down from Paris, as to Messrs. Harmsworth and Bird in the former's new 12 horsepower Serpollet steam car, and as to the author of *Footsteps of a Throne* in Mr. Harmsworth's 12 horsepower Panhard, driven by Engineer Lancaster, than whom a better exists not. Colonel Crompton and Claude Crompton swelled the party later, having cycled from Paris.

Mr. Harmsworth was good enough to take us out to the finishing point about  $2\frac{1}{2}$  to 3 miles from the city at a crossing of ways called Les Quatres Pavillons, 345.89 miles from the starting point at Saint Cloud, in his Serpollet, and though 3 miles is little enough to have of so entrancing a vehicle, it was enough to convince us that that car is quite the most luxurious road-traveling vehicle in which we have yet ridden. Owing to the absurdly optimistic prophecies of *Le Vélo* and *L'Auto Vélo*, we ran out over the horridly paved Bastide Bridge, and the full mile of tram-lined pavé beyond, and climbed the hills out to the Quatre Pavillons, so as to be there before 10 o'clock. As the flying Fournier never arrived until nine minutes past 1, the odd hours were made to pass as well as might be by watching and criticising the automobiles which went speeding outward toward Libourne in order to take up favorable positions. Verily we believe every ear in Bordeaux was requisitioned for the finish of this great event, for they swept by in battalions and clouds of dust. In the intervals inquiries were made as to what was known anent the progress of the race, and occasional telephone messages to the house of M. Journu, of the Automobile Club Bordelaise, which was hard by, were made known. First we heard that Fournier and his Mors were leading well at Chattellerault, 166 miles away, having passed Levegh, and that Gi-



rardot, the ultimate cup winner, had smashed his clutch at Chartres. Later came the news that Fournier was leading the next man Voigt at Ruffec, 101 miles away, by twenty-five minutes, and that lots of punctures, owing to nails on the roads, had been suffered by many competitors. The time wore slowly on in the great heat and dust, until another message came through to the effect that Fournier had left Libourne, 15 miles away. Then the crowd, which made up in enthusiasm what it lacked in numbers, braced themselves with the expectation of excitement. The minutes passed almost in silence, so tense had the feeling become. Even the camelots ceased to cry *Le Vélo*, and like all the rest strained their eyes upon the brow of the hill over which the petrolic Jehu speeding toward them must come. Suddenly a cry went up from the high bank on the right, *Le voila!* and at the top of the narrowed way between the poplar tops as they descended the reverse side of the slope were seen to be blotted out as with a cloud. The cloud, as it appeared, surged over the top of the hill, descended with awful rapidity, and whirled toward us. It showed a black eye, which every instant increased in size. The eye was the Mors, whose wildly whirring engine was now distinctly audible. Machine, men, and cloud, which blotted out all behind, rushed up the winning slope, and amid the wild cries of all who witnessed, completed the most remarkable automobile run yet accomplished. Over an hour and a half elapsed before the second man was in, and the same wild scene of welcome was enacted, though in lesser degree with each arrival. The following table gives these as they occurred; also the average speed per hour throughout the journey:

CLASS 4.—*Cars weighing 12 $\frac{3}{4}$  hundredweights and over.*

Character of machine.	Chauffeur.	Net time.		Miles per hour.
		H.	M. S.	
50 horsepower Mors .....	Fournier .....	6	7 44	53.51
40 horsepower Panhard-Levassor .....	Farman .....	6	37 15	49.95
Do .....	Voigt .....	7	12 11	45.54
Do .....	Pinson .....	7	42 51	42.51
Do .....	Axt. ....	7	43 17	42.38
Do .....	Hourgères .....	8	39 39	37.87
Do .....	De Crawhez .....	8	51 34	37.02
Do .....	Farman .....	9	27 50	34.65
Do .....	De Berteaux .....	11	6 39	29.50
Do .....	Lefebvre .....	11	38 50	28.10

CLASS 3.—*Cars weighing from 7 $\frac{3}{4}$  hundredweights to 12 $\frac{3}{4}$  hundredweights.*

Panhard-Levassor .....	Giraud .....	8	21 48	39.21
Darracq .....	Baras .....	8	38 5	37.98
Do .....	Edmond .....	10	21 4	31.68
Béconnais .....	Béconnais .....	10	37 25	30.87
(?) .....	Sauz .....	11	6 26	29.53
Decauville .....	Théry .....	11	7 42	29.47
Darracq .....	Rudeaux .....	11	45 58	27.87
Do .....	Ullman .....	12	12 20	26.87
Do .....	Filitz .....	13	53 59	23.59
Decauville .....	Chabrière .....	14	1 4	23.39

CLASS 2.—Cars from  $4\frac{1}{2}$  hundredweights to  $7\frac{3}{4}$  hundredweights.

Character of machine.	Chauffeur.	Net time.	Miles per hour.
		H. M. S.	
Renault .....	L. Renault .....	9 28 27	34.62
Do.....	M. Renault.....	9 36 14	34.15
Do.....	Oury.....	10 40 50	30.71
Do.....	Grus.....	10 50 41	30.25
Lof.....	G. Lot.....	15 51 4	20.69

## CLASS 1.

De Dion-Bouton tricycle .....	Teste .....	7 57 0	42.38
Do.....	Osmond .....	7 59 27	41.04
Do.....	Collignon .....	9 5 33	35.89

Seven other tricycles came through at various intervals, the last being Buquet, who occupied  $13^h 43^m 10^s$ .

The average mileages of the first seven arrivals will be found to be less than those we cabled from Bordeaux, but at that time we were not in possession of the total distance neutralized by the controls, and the times given us by the timekeeper were less  $2^h 37^m$  the time of neutralization. The distance so neutralized was  $17\frac{1}{4}$  miles, which accounts for the reduction of the averages previously given. Although Messrs. Harmsworth, Bird, and Pemberton were members of the A.C.G.B. and I., and Mr. Bird was actually nominated as one of the judges by the French club, while Colonel Crompton represented the British war office committee, they received very scant courtesy at the hands of the clubmen. Mr. Bird at least might, we think, have been offered something more than the hospitality of the road, wherein he remained throughout the day. It was only after meeting with our old friend M. Paul Rousseau, the director of Le Vélo, that we obtained access to the timekeeper, and were able to get the particulars always freely offered to representatives of the press.

The little party of the six English returned to Paris on the following day per the Paris rapide, which occupied  $1^h 26^m 16^s$  more in making the journey than had Fournier on the previous day.

IV.—PARIS TO BERLIN. <sup>a</sup>

On the 27th of June, 1901, at half-past 3 in the morning, the official starter of the Automobile Club of France sent off the first automobile from Paris for Berlin, and in turn, every two minutes, 108 vehicles followed after the first.

The day before, all these vehicles had been put in first-rate order by the attendants of the automobile club and the proprietors had paid to the customs as a guaranty that they would be brought back to France 12 per cent of their value, which amounted to the handsome sum of 1,250,000 francs.

<sup>a</sup>Translated from L'Illustration, Paris, July 6, 1901.



FOURNIER ON THE ROUTE TO BERLIN.







THE AUTOMOBILE OF BARON ZUYLEN, PRESIDENT OF THE AUTOMOBILE CLUB OF FRANCE.

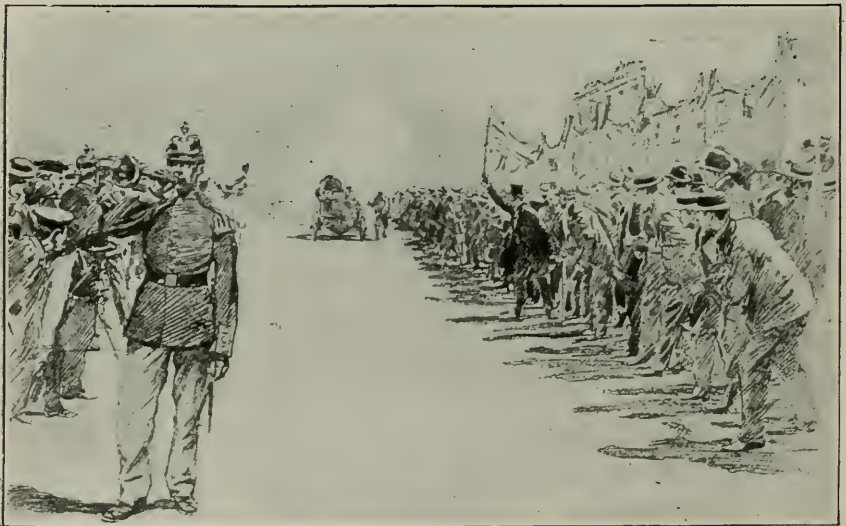

PRUSSIAN TRUMPETER ANNOUNCING THE APPROACH OF AN AUTOMOBILE.

A sporting event of such evidently exceptional importance had stirred up all the automobile world. The French constructors had gained in a very little time a notable place in the new industry and the machines from their workshops had hitherto led all others. Few foreign competitors had entered before, but this time England and Germany came forward prepared for a serious struggle.

The route chosen in the east of France, Belgium, Luxembourg, and Germany was hard and dangerous, being 748 miles, in three divisions (285 miles from Paris to Aix-la-Chapelle, 278 miles from Aix-la-Chapelle to Hanover, and 185 miles from Hanover to Berlin). In the second and third divisions the narrow, uneven, and only partly paved roads offered very unfavorable conditions to the pneumatic tires and there were no expectations of reaching the 80 kilometers an hour which had easily been obtained on the good roads. There was especial need to show prompt decision and coolness, especially as the populace along the road, still unfamiliar with the new method of locomotion, was crowding to see the new vehicles, prompted by a curiosity which only created an additional trouble for the drivers.

In spite of all these difficulties the winner of the race, Fournier, mounted on a French automobile supplied by the Mors Company, furnished with Michelin pneumatic tires, reached Berlin in 16<sup>h</sup> and 6<sup>m</sup>, gaining one hour and a half on the Northern Express; and this exploit was not the only one, for following it Girardot arrived in 17<sup>h</sup> and 1<sup>m</sup>, René de Knyff in 17<sup>h</sup> 4<sup>m</sup>, while among the light vehicles Giraud took about 19<sup>h</sup> and 33<sup>m</sup>, Louis Renault, in the Voiturette, 19<sup>h</sup> 16<sup>m</sup> and 25<sup>s</sup>, and Osmont, on a simple motorcycle, in 18<sup>h</sup> 59<sup>m</sup> and 50<sup>s</sup>.

We have endeavored to present graphic pictures of this closely fought contest, and to bring out thereby its notable characteristics.

At Aix-la-Chapelle, Fournier arrived in the midst of the frenzied shouts of thousands of spectators, the crowd pressed on the track for more than three kilometers, refusing to obey the soldiers who were there to secure order, and closing the entire roadway up to the very last minute, when a trumpeter in pointed helmet sounded a call at the same time to warn the troops of the approach of the vehicles and the too enthusiastic spectators to get out of the way. The automobiles were afterwards taken to the park, where they were to be kept under military guard until next day, and around the yet hot vehicles still pressed the crowd. Outside the barrier there was great excitement on the arrival of every new automobile. The constructors sent mechanics charged with the urgent repairs out at every stage of the road, and they were pressing their way to the barriers, eager to get to work, for the drivers have just a quarter of an hour to indicate what work to do, and just a quarter of an hour only to repair all the injuries suffered by the machines on the road. These fifteen minutes elapsed, at the command of the constructor, the drivers must quit the spot, after which

comes the turn of the mechanical specialists for the repairs of the "pneus," change of air chambers, and like delicate work, which they accomplish with a dexterity which is almost miraculous. Finally, it is only after they have looked for all these things, after the grooming, so to speak, of the racer, that the chauffeur in his turn is at liberty to think of taking a bath and of enjoying an hour of well-earned sleep.

At Hanover the crowd is also considerable, and the reception equally enthusiastic, and the park where the vehicles are taken swarms likewise with hurried people, dusty machines, and long rows of oil cans.

At each stage, the number of vehicles sensibly diminishes; of the 109 which left Paris, 77 only reached Aix-la-Chapelle, 62 Hanover, and only 45 got to Berlin. The arrival at Berlin took place on Saturday, the 29th of June, at the Hippodrome of the West End Railway, 4 miles out of town. Everybody in the city of Berlin was present, and uniforms were mixed with pretty toilets, and everything ranging from automobile costumes to the most extraordinary garments being seen together.

The morning breeze which brought up clouds of fine dust gilded by the sun, united in the same folds the French and the German banners.

At 11<sup>h</sup> 45<sup>m</sup> 22<sup>s</sup>, Fournier arrived at full speed, and in an instant was covered with tri-color crowns, taken from his automobile, and carried off in triumph. A similar ovation attended the second, Girardot. At this time the enthusiasm was indescribable.

At 3 o'clock the automobiles went through Berlin in one long procession saluted in their passage by frenzied acclamations. They made a sensational entry to the barracks of the grenadiers of the "Emperor Alexander," where they were to be classed before their departure for the exhibition of automobiles just opened in Berlin, of which they were to be the leading feature. It was one of the most striking circumstances that these pacific machines should go into this German barrack with its prison discipline, and it was curious to see with what wondering, laughing eyes the stiffly moving soldiers looked at their strange visitors.

The prizes to the winners of the different classes were awarded as follows: To Fournier, the prize of the Emperor of Germany, of the King of the Belgians, of the Grand Duke of Luxembourg, and of the city of Hanover. Werner, the Sevres vase given by the President of the French Republic. Girardot, the prize of the Grand Duke of Luxembourg.

The first of the voiturettes, Louis Renault, was awarded the prize of the ministry of commerce.

This great exhibition of automobilism will doubtless be the last one of its kind which we shall see, for it has caused several accidents, doubtless inevitable, one of which was quite severe, a child having been crushed at Rheims by one of the automobiles on its passage, and



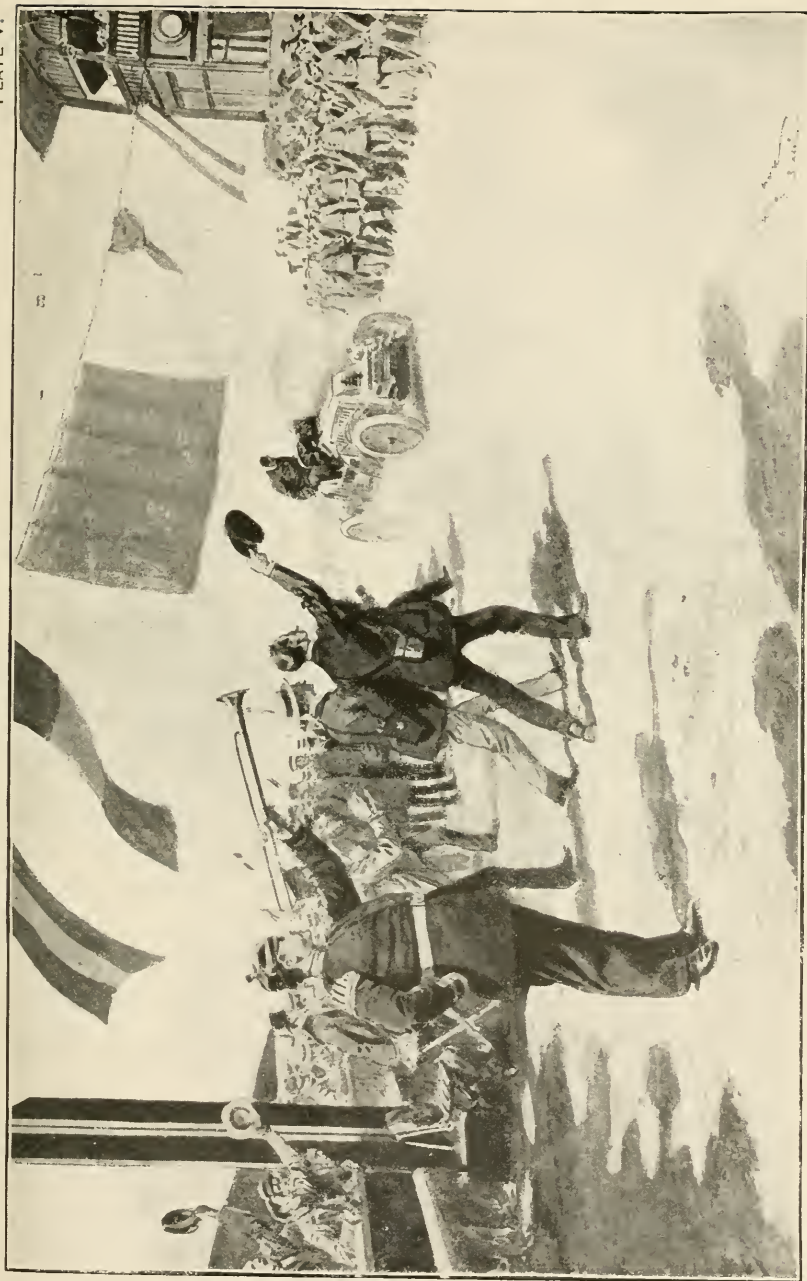

WELCOMING FOURNIER, THE WINNER, AS HE CROSSES THE LINE.





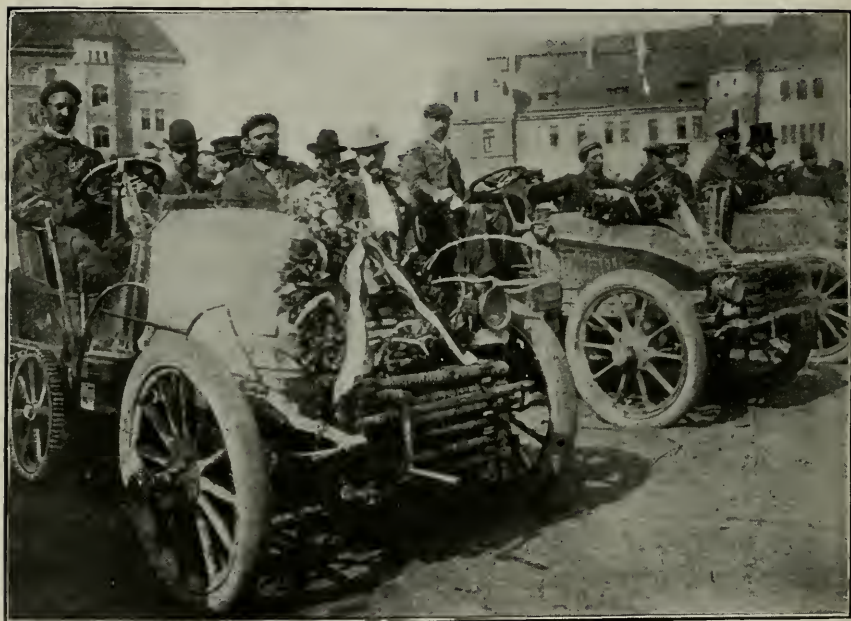

THE VICTORS IN THE GRENADIER BARRACKS.

the President of the Chamber of Deputies was obliged to reply to Mr. Géralt-Rechard who had spoken for those affected by the fatal drama, that the Government shared the anxiety of the public, and that it would try to prevent the recurrence of any such sad accidents, so that probably we shall see no more of such races as this.

We shall not greatly regret it. These tests have done great service to the constructors and to industry in general, and we shall have no future need of demonstrating that an automobile can go a hundred kilometers an hour when it is exceptionally well constructed and driven by an exceptional man. We shall be able to find other and simpler methods of demonstrating the celerity, regularity, and endurance which we have a right to demand after the first year of trial of this new locomotion.



## THE ERECTION OF THE GOKTEIK BRIDGE.<sup>a</sup>

By DAY ALLEN WILLEY.

What is known as the Gokteik Viaduct, recently completed in Burma, Asia, is notable for its height, length, and the remarkably short time in which it was built, considering the obstacles to be overcome. As the bridge was planned and the material made in this country, and most of the important work was done by Americans, it forms another indication of the progress which our bridge-building industry is making abroad. The structure, which is located about 80 miles from Mandalay, connects portions of the line of the Burma Railway Company between Mandalay and Rangoon. It is one of the long railway bridges of the world, being 2,260 feet in length, and, with two exceptions, it is the highest, the railway track being 320 feet above the natural bridge which forms its foundation. The famous Loa Viaduct in South America is 336 feet high, but only 800 feet in length. The Pecos Viaduct in Texas is 321 feet in height, but 80 feet shorter than the Gokteik structure, while it contains but 1,820 tons of metal. The new Kinzua bridge on the Erie Railway in Pennsylvania is but 2,035 feet long and 19 feet lower at its highest point, although it contains 3,250 tons of metal.

The erection of the bridge was begun December 1, 1899, and completed on October 16, 1900, the construction force consisting of 35 employees of the Pennsylvania Steel Company, which took the contract; 15 Europeans, and about 450 native laborers, secured principally from the vicinity of Calcutta, India. The plans, which were prepared by Mr. J. V. W. Reynders, superintendent of bridge construction of the Pennsylvania Company, called for a series of 14 single towers, one double tower, and a rocker bent, which, with the abutments, carry ten 120-foot truss spans and seven 60-foot plate-girder spans. The viaduct, for 281 feet at one end and 341 feet at the other end, is curved to a radius of 800 feet, and between these two curves there is a tangent of 1,638 feet. The height of the structure above the ground is 130 feet at one end and 213 feet at the other end. The viaduct was designed to carry a double-track road and a foot walk, but the floor system for the foot walk and one track only is constructed at

<sup>a</sup> Reprinted, by permission, from the *Scientific American*, August 17, 1901.

present. The single towers consist of two transverse trestle bents, braced together in all directions. The double tower consists of three trestle bents. So far as practicable, the members of all bents were made interchangeable.

Except seven plate-girder spans, located at the ends of the viaduct, all of the connecting spans are made up of two 120-foot deck trusses. These trusses carry 27-inch plate-girder floor beams spaced 13 feet

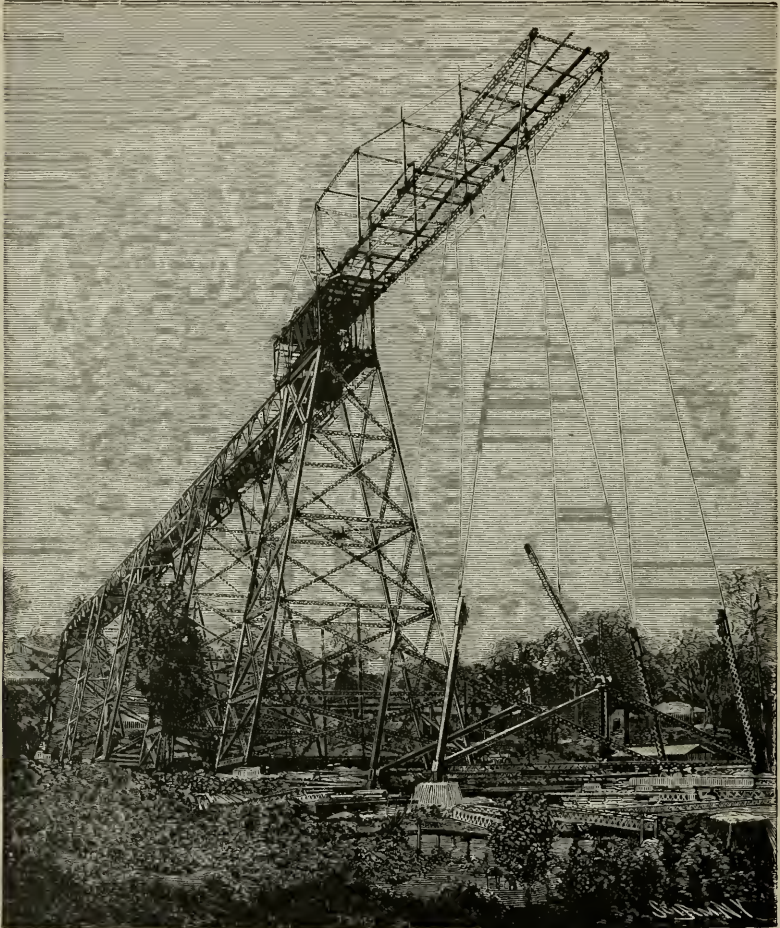

Traveler supporting columns during tower construction.

apart, which in turn support the track stringers. The top flanges of the trusses, floor beams, and stringers are made flush, and are covered over with a solid floor of five-sixteenth inch flat plates.

To handle the material a special traveler was designed and constructed at the works of the Pennsylvania Company, shipped to Asia with the bridge material, and put together at the gorge. This is by far the largest traveler ever built, having an overhang of 165 feet



and weighing 80 tons. Its maximum lifting capacity is 30 tons. It consists of 3 trusses, two of which are connected by transverse bracing, built on the cantilever plan, each being 219 feet in length, 40 feet in height, and separated by a width of  $24\frac{1}{2}$  feet. The lower chords of the traveler supported four trolleys, each provided with a chain hoist having a lifting capacity of 16 tons. Powerful clamps were especially designed for holding the rear end of the traveler to the girders of the viaduct, and it was supported on a series of wheels enabling it to be easily moved as the work progressed. Most of the material was lowered from above by the traveler. In

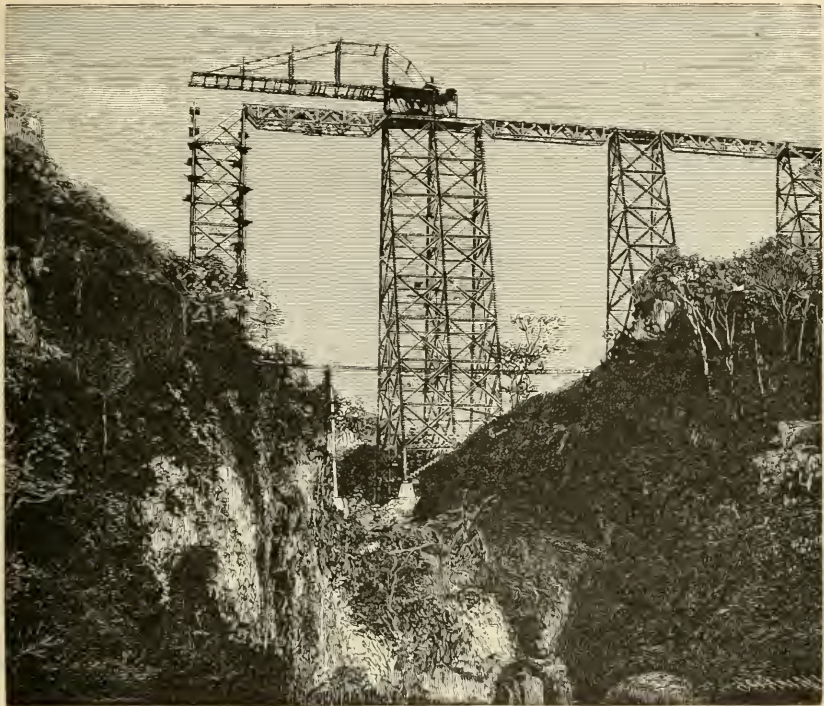

Gorge and main towers with bridge under construction.

erecting the towers crossing the deepest portion of the gorge a temporary track was built on a wooden trestle at an elevation of about 100 feet above the base, and material for the lower parts of the towers hauled to the spot and transferred to their positions by special derricks.

An idea of the quantity of material placed in position can be gained when it is stated that it comprised most of the cargoes of three steamships, and when loaded on the cars at Steelton, Pennsylvania, represented a solid train  $1\frac{1}{2}$  miles long. The erection plant alone weighed 250 tons, and, in addition to the traveler, included three hoisting engines, a series of air compressors, a telephone system for communication between the gangs working at each end of the viaduct, and the

necessary chisels, hammers, and other tools for bridge construction. At the outset heavy rains interfered considerably with the progress of the work, the violence of the storms being so great that it was seldom possible to do any work between noon and sundown. The temperature ranged from below the freezing point at night to over  $90^{\circ}$  in the shade in the forenoon. Another delay was caused by the refusal of the native laborers, on account of their superstition, to use compressed air in riveting, and nearly all of this was done by hand, although the plans called for 192,000 rivets in the field work alone.

The usual plan followed in bridge construction of indicating the

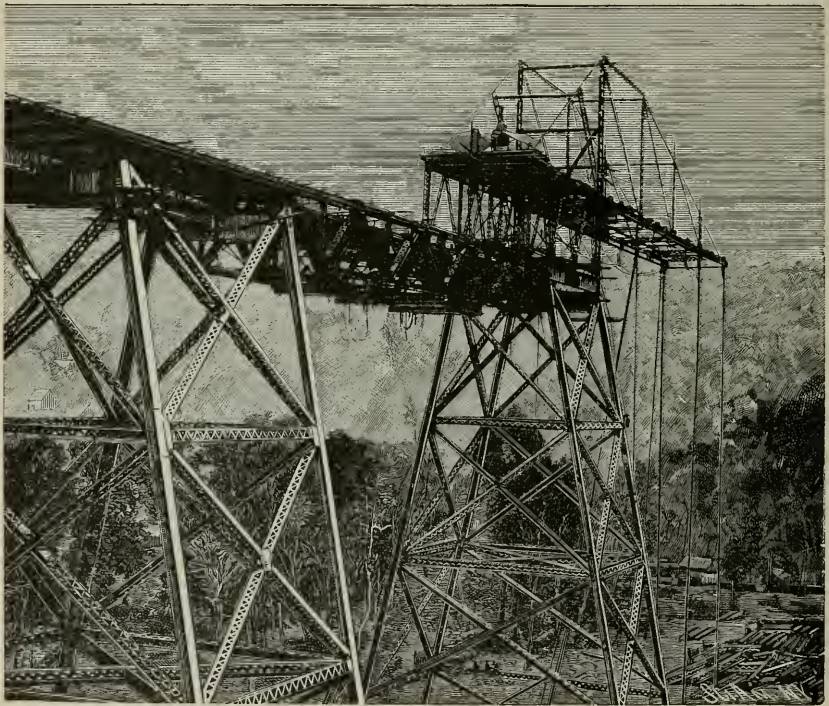

View of traveler showing opposite side of gorge in the distance.

locations of different parts by numbers and letters could not be followed in this case owing to the ignorance of the natives; so a color scheme was adopted, by which each column and girder was given a distinctive color, and the joints between the columns painted with a combination of stripes. All the erection outfit was painted black to distinguish it from the bridge material proper. In this way the thousands of pieces were handled and put in position without difficulty. In beginning the construction of the viaduct the steel was hauled to the end of the track and deposited in a temporary storage yard in such a manner that it could be lifted by the traveler. Thus the first towers were erected. As these were placed in position the superstructure was

fastened to them and the traveler moved forward. Then the material was loaded on flat cars, pushed out upon the bridge, and transferred from the cars into position.

Owing to the height of the bridge and the extreme changes in temperature careful provision had to be made both for the wind pressure and the unusual contraction and expansion of the metal. The bridge was built to carry a load of 2,240 pounds to each linear foot of track, in addition to two locomotives, each weighing 54 tons. It is to withstand a wind pressure of about 34 pounds per square foot when a train is upon it, and about 56 pounds per square foot at other times. These calculations were made by the consulting engineers of the railway company—Messrs. Sir Alexander Rendel & Co., of London, represented by Mr. W. H. Clark. The viaduct was erected under the supervision of Mr. D. Duchars, chief engineer, and Mr. J. A. White, resident engineer.

As already stated, a portion of the viaduct is located upon a natural bridge. This is a rocky formation which is just wide enough to safely support the towers. Two hundred feet below its summit flows a river which has forced a channel beneath the formation, so that the total height of the bridge above the water is 520 feet.



## THE GREAT ALPINE TUNNELS.<sup>a</sup>

By FRANCIS FOX, Esq., M. Inst. C. E., M. R. I.

The subject for this evening's discourse is that of the three great tunnels through the Alps, viz, the Mont Cenis, the St. Gothard, and that which is now in course of construction—the Simplon.

But before dealing with the details of these particular works it will be desirable to consider what tunneling is, and also some of the more remarkable instances of it in bygone days.

One great drawback in connection with the subject—so far as a discourse is concerned—is its unsuitability for the photographic art. Unlike a battle ship, or a splendid bridge, or a grand block of buildings, which can be made into fine views and pictures, the work of the mole is hardly adapted to the sensitive plate. I therefore propose to make use of the "language of the pencil," and to make a few rough sketches on the blackboard. By these means I trust I may be able to explain some of the difficulties which have to be encountered, and also show how a tunnel is constructed. The child's definition of drawing, "first you think and then you draw a line round your think," will come to our aid.

The art of tunneling dates back to very remote ages, and there are records of such works which were constructed five hundred to six hundred years before the Christian era.

An interesting account is given by one of your most distinguished members, in an article in the *Encyclopædia Britannica*, of the tunnel under the River Euphrates, at Babylon. This city, similar in some respects to London, lay half on one side and half on the other side of the river. High walls, penetrated by occasional gates, surrounded the city and lined each of the banks of the river. These gates (of which a pair of the great hinges can be seen in the British Museum) were closed at night and during war; and a tunnel was constructed below the bed of the river by means of what is technically known as the "cut-and-cover" system. In those days the Greathead shield was unknown, and consequently the river had to be diverted so that the excavation could be made in the dry bed and cut open to daylight, the

---

<sup>a</sup> Reprinted from Proceedings of the Royal Institution of Great Britain, Vol. XVI, Part I, 1901. Read at weekly evening meeting, Friday, May 25, 1900, His Grace the Duke of Northumberland, K. G., F. S. A., president, in the chair.

arch being built, the ground restored, and the river allowed to resume its former course. The tunnel is said to have been 15 feet in width and 12 feet in height, built of brick.

Herodotus gives an account of the diversion of the river into a great excavation or artificial lake 40 miles square, and states that the besieging enemy, so soon as the water was drawn off, entered into the city by the river bed. It is believed that this same excavation was made use of for the construction of the tunnel. It is, however, desirable to state that doubts have been thrown on the subject, and it is possible that it may have to be relegated to mythology.

The next instance of a tunnel is that referred to by Herodotus in the Island of Samos,<sup>a</sup> and it is satisfactory to know that although very considerable doubts were expressed as to the accuracy of his statements, recent investigations prove that he was exactly correct. The description given by him, when expressed in English words and figures, is as follows:

“They have a mountain which is 910 feet in height; entirely through this they have made a passage, the length of which is 1,416 yards. It is, moreover, 8 feet high and as many wide. By the side of this there is also an artificial canal, which in like manner goes quite through the mountain; and though only 3 feet in breadth, is 30 feet deep. This, by the means of pipes, conveys to the city the waters of a copious spring.”

The commentators on this passage say that Herodotus must have made a mistake, but the Rev. H. F. Tozer, in his book *The Islands of the Ægean*, page 167, gives the results of a personal visit.

He says the tunnel is 7 to 8 feet in width; that two-thirds of its width is occupied by a footpath, the other third being a water course, 30 feet deep at one end. He and other writers consider that insufficient allowance was made for the fall of the water, and that the water channel had to be deepened. To describe it in more modern language, the resident engineer evidently made a mistake in his levels, necessitating a much deeper excavation than was at first anticipated.

Another and, if possible, a more interesting instance of tunneling is that described in the *Proceedings of the Palestine Exploration Society*, in connection with the Pool of Siloam, made by Hezekiah, B. C. 710, 2 Kings, xx, 20.<sup>b</sup> (See fig. 2.)

About 710 B. C. a tunnel was driven from the spring to the well—by actual tunneling—the work being commenced at the two ends, and by shafts, and the workmen met in the middle. The tunnel was only

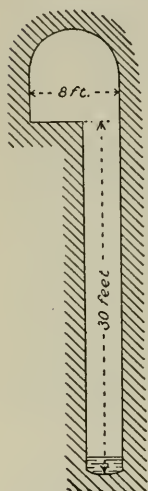

FIG. 1.—Cross section of the Aqueduct of Eupalinos, in the Island of Samos.

<sup>a</sup> Herodotus, III, p. 60.

<sup>b</sup> Palestine Exploration, 1882, p. 178.

2 feet in width, and 3 feet in height, except at the probable point of meeting, where the height is 4 feet 6 inches. The length is 1,708 feet, and there is a fall of 1 foot in this distance. About the middle of its course there are apparently two false cuts, as if a wrong direction had been taken; but possibly these were intentional, and provided passing places for the workmen and material.

On the soffit of the tunnel is carved an inscription, of which the following is a translation:

“Behold the excavation. Now this had been the history of the excavation. While the workmen were still lifting up the pick, each toward his neighbor, and while 3 cubits (4 feet 6 inches) still remained to cut through, each heard the voice of the other, who called to his neighbor, since there was an excess of rock on the right hand and on the left. And on the day of the excavation the workmen struck each to meet his neighbor pick against pick, and there flowed the waters from the spring to the pool for 1,200 cubits (1,820 feet), and 100 cubits (151 feet) was the height of the rock over the head of the workmen.”

A Roman engineer gives an account of a tunnel which was being driven under his directions for an aqueduct. And as he was only

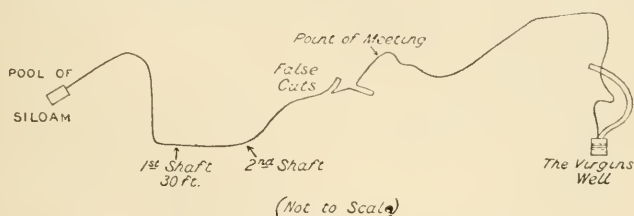

FIG. 2.—Plan of Tunnel from Spring to Pool of Siloam.

able to visit the work occasionally, he describes how on one of his visits he found the two headings had missed each other, and he says that had his visit been deferred much longer there would have been two tunnels.

The accurate meeting of the headings or driftways of a tunnel can only be attained by the exercise of great care, both as regards direction as well as level.

We need not go very far to find instances of such an error as inaccurate meeting, but there is one well-known case on an important main line in the Midland counties where the engineers failed to meet, and to this day reverse curves exist in the tunnel to overcome the difficulty.

To attain this accurate meeting fine wires are hung down the shafts of a tunnel, with heavy plumb bobs suspended from them in buckets of water, or of tar, to bring their oscillations to rest, the accurate direction being given by means of a theodolite or transit instrument on the surface.

The wires are capable of side movement by means of a delicate instrument (which is on the table), and are gradually brought exactly

into the same vertical plane; hence, if they are correct at "bank," or surface, they must also be correct below ground. The engineers below have to drive the galleries or headings so that only one wire is visible from their instrument; so long as one wire exactly eclipses the other wire, the gallery is being driven in the right direction.

As regards accuracy in levels, this is done by ordinary leveling; but it will be seen at once how much depends on care being devoted to both these operations.

Assume two shafts, 1,000 yards apart, between which a gallery has to be driven, and allowing a distance of 10 feet between the wires, which are one-fortieth inch in diameter, an error of the diameter of the wire at the shaft will cause a mistake of nearly 4 inches at the point of meeting, or of  $7\frac{1}{2}$  inches if a similar error occurs at the other shaft in the opposite direction. The trickling of water down the wires increases their diameter so appreciably, and therefore conduces to further inaccuracy, that it is found necessary to fix a small shield or umbrella on the wire to deflect the water. (This shield is to be seen on the table.)

Some years ago, a tunnel which had been commenced, but not fin-

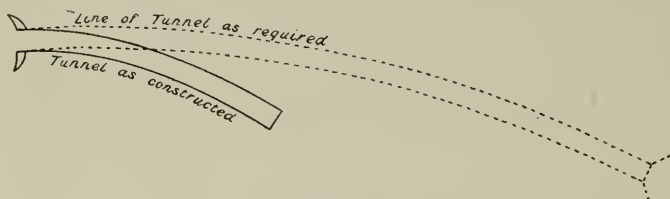

FIG. 3.—Plan.

ished, had to be completed. The first thing to be done by the engineers was to make an accurate survey of the then condition of the work—this rough sketch (see fig. 3) indicates what was discovered. The explanation given by the former "ganger" was, that he found the rock too hard, and he thought that by bearing round somewhat to the right he might get into more easily excavated material!

When the wires are hung down the shaft it is sometimes almost impossible to prove that they are not touching, and consequently being deflected from the true vertical line by some rope or pipe, staging or timber in the shaft. To overcome this, an electrical current was passed down the wire—a galvanometer being in circuit. If the wire proved absolutely silent, and no deflection was obtained in the galvanometer, the conclusion could be safely drawn that the wire was hanging freely and truly.

In driving the necessary adit or heading for drainage purposes beneath a subaqueous tunnel, a rising gradient from the shaft bottom of 1 in 500 is allowed, to enable the water at the "face" to flow away from the workmen to the pumps in the "sump" or shaft bottom (see fig. 4).



When the heading is driven sufficiently forward to justify the commencement of the main tunnel, a fresh difficulty presents itself. This main tunnel has to be driven down hill, and consequently the water collects at the working face A; the bottom can not therefore be removed until a bore-hole is put down from A to *a*. When this is done the remaining excavation can be taken out, and a further length of tunnel driven to B. A bore hole is now sunk from B to *b*, whilst that from A to *a* can be plugged up; and thus the tunnel is gradually advanced.

By the adoption of the Greathead shield much of this difficulty can be avoided; but one subaqueous tunnel through water-bearing strata, at considerable depth, is sufficient for a lifetime.

As an illustration of the danger to which men are exposed in such work, it is stated, with much regret, that in a certain tunnel, notwith-

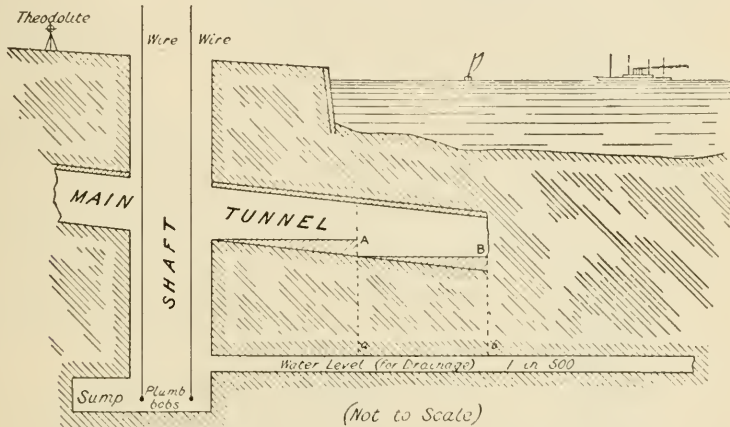

FIG. 4.—Diagrammatic section to illustrate method of constructing tunnel below river bed.

standing every precaution being taken, all the men engaged in driving the drainage heading by means of a tunneling machine have died; and in the case of the first Vyrnwy tunnel crossing of the River Mersey—driving by Greathead shield under pressure—the mortality was great.

Having explained in very general terms some of the difficulties of tunnel construction, we will proceed to the case of the great tunnels through the Alps, and for the purpose of rendering the subject more easily intelligible, the following particulars may be given:

	St. Gothard.	Mont Cenis.	Arlberg.	Simplon.
Length of tunnel in miles.....	9.3	7.98	6.36	12.26
North or east portal above sea level.....feet..	3,639	3,766	4,296	2,254
South or west portal above sea level.....do.....	3,757	4,164	3,998	2,080
Highest level.....	3,788	4,218	4,300	2,314
Maximum grade in tunnel per 1,000.....	5.82	30	15	7
Maximum height of mountain above tunnel.....feet..	5,598	5,428	2,362	7,005
Possible maximum temperature of rock.....deg. Fahr..	85	85	65	101

## MONT CENIS TUNNEL.

The Mont Cenis, or as it is more accurately called, the Frejus Tunnel, is nearly 8 miles in length. It is for a double line of way, width being 26 feet and height above rails 20 feet 6 inches. The construction is of excellent character, and it is lined throughout with either masonry or brickwork, except for two lengths of 100 meters and 70 meters, respectively. In these two lengths solid white quartz was encountered, and two years were occupied in penetrating it. The gallery of direction is straight throughout the actual tunnel, being curved away to the portals.

The system of setting out will be described in more detail when we come to consider the case of the Simplon, but in passing we may remark one peculiarity which does not attach to the other tunnels, viz, that the gallery of direction on the Italian side is shut off by a massive grating from the railway tunnel, and is occupied by guns and Gatlings and by a detachment of artillery, the French portal being commanded by an armor-plated fort.

The approaches to the tunnel, both on the Italian and French sides, are severe, amounting to 30 per 1,000 or 1 in 33 on the former, and 25 per 1,000 or 1 in 40 on the latter.

Owing to an alteration during construction on the Bardonnechia side, it became necessary to introduce an ascending gradient for about 1 kilometer in length at the Italian end of the tunnel, and this has resulted in seriously compromising the ventilation.

A rough diagram will serve to give an idea of the gradients and the consequent difficulty in working the traffic.

Trains coming from France with an ascending gradient of 1 in 40 against them for a length of 7 kilometers, when followed by a current of air in the same direction, produce a most disastrous state of things. In this tunnel, as in all other steep tunnels, engines having a heavy load behind them go through with their regulator full open, ejecting great volumes of smoke and steam, which travel concurrently with the train, and the inconvenience and discomfort produced are very great.

At each kilometer in the tunnel a refuge or "grande chambre" is provided for the men, and this is supplied with compressed air, fresh water, a telephone in each direction out, a medicine chest, barometer, and thermometer.

The custodians of the tunnel go in pairs, and if one man is affected by the want of oxygen or dense smoke, the other can render assistance or telephone for further help. The men can retire into these chambers, close the door, turn on the air, and wait either for the tunnel to clear or for a locomotive to fetch them out.

The temperature in the middle of the tunnel remains nearly constant, summer and winter, and is about  $19^{\circ}$  to  $20^{\circ}$  C. =  $66^{\circ}$  to  $68^{\circ}$  F.

The altitude of the tunnel is 4,248 feet above sea level, and the

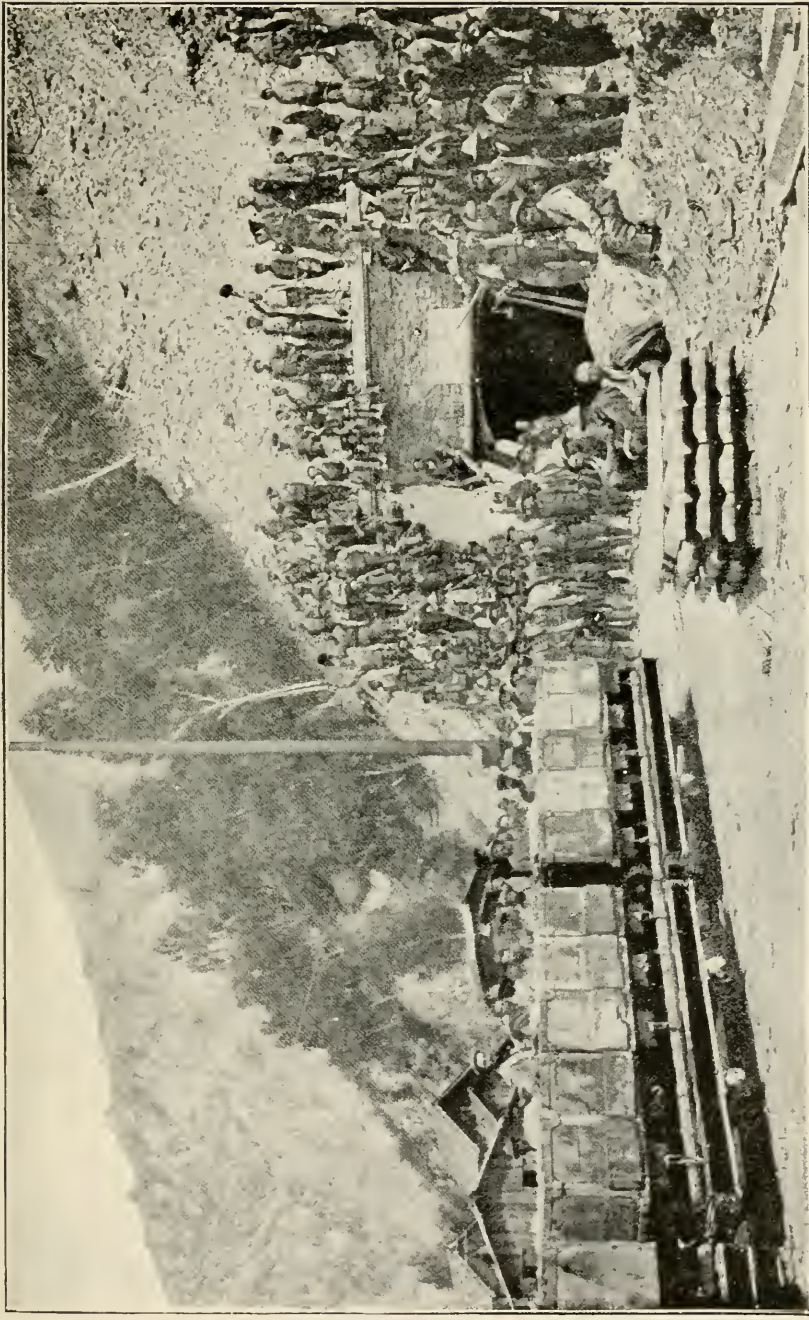

SIMPLON TUNNEL. MINERS ABOUT TO ENTER THE TUNNEL AT BRIGUE, IN THE RHONE VALLEY. THE METHOD OF TRANSPORTING THE SMALL HAND TUNNEL WAGONS UPON LARGER TRUCKS IS SHOWN.



height of the mountain above the tunnel is 5,428 feet; the temperature of the rock is greatly influenced by this latter fact.

The question of the temperature of the rocks passed through in the construction of a tunnel is one of great interest, as it depends upon several conditions: (1) The character of the rock; (2) the inclination of the beds, those which attain a vertical or nearly vertical position being less able to confine the heat than those which are more or less horizontal; (3) the height of the mountain above the tunnel, or, in other words, the thickness of the blanket.

A diagram is shown (see fig. 5) giving the temperature actually encountered in the St. Gothard and Arlberg tunnels, and from these, aided by the carefully prepared geological section along the center line of the Simplon Tunnel, an approximate line (in red) is given of the temperatures which are expected.

The possibility of cooling the rocks and the air of the tunnel will be dealt with later on, but there is in addition a permanent lowering of the temperature after the tunnel is complete, particulars of which will be given under the description of the St. Gothard.

For each 144 feet of superincumbent rock or earth the increase is found to be 1° F.

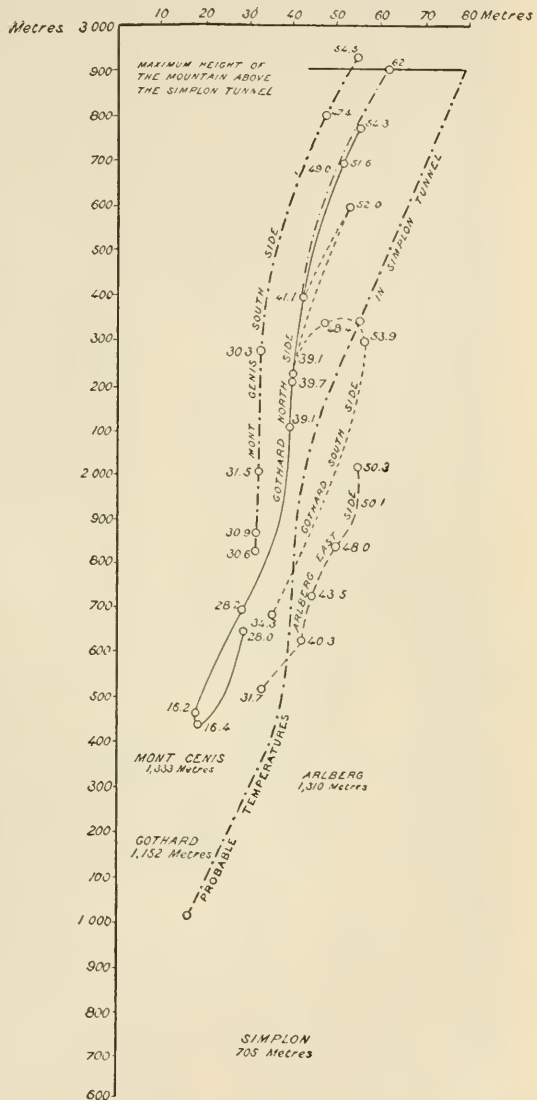

Fig. 5.—Curves showing depths corresponding to an increase in temperature of 1° C. for the Mout Genis, Gothard, and Arlberg tunnels (with curve of probable temperature for the Simplon Tunnel).

## THE ST. GOTHARD TUNNEL.

This, which is at present the longest railway tunnel in the world, is 9.3 miles in length, and constitutes the summit of the "Gothard bahn"—that is, the railway which runs from Lucerne to Chiasso on the Italian frontier. There are about 100 tunnels in all, most of which are for double line of way, the permanent way being very heavy, the rails weighing 100 pounds to the yard.

The altitude of the tunnel at its north portal is 3,639 feet, and at its south portal 3,757 feet above the sea. A gallery of direction was driven throughout, and the gradient of the rails is only such as to provide for efficient drainage, viz., 5.82 per 1,000, or about 1 in 172.

The following table may be of interest, giving the result of investigations as to the cooling of the rocks:

TEMPERATURE OF THE ROCK IN THE ST. GOTHARD TUNNEL.

[Degrees are centigrade.]

Date.	7.3 kilo. from the north portal.			7.05 kilo. from the south portal.		
	Temperature.	Lowering.		Temperature.	Lowering.	
		Successive.	Total.		Successive.	Total.
April and May, 1880, the year when the tunnel was pierced.....	0	0	0	0	0	0
June, 1882.....	30.46	.....	.....	30.53	.....	.....
July, 1883.....	23.73	6.73	.....	23.39	7.14	.....
.....	22.20	1.53	8.26	23.1	0.29	7.43

Although the works were carried on with energy, and with all the best appliances then known, the time occupied was ten years; but the most serious feature of the work was the heavy mortality among the men. No less than 600 deaths occurred, including those of both the engineer and contractor.

From the experience then gained great improvements have been introduced into the works of the Simplon, as will be described later on; but the heavy loss of life in the St. Gothard was due to insufficient ventilation, the high temperature, the exposure of the men to the Alpine climate after emerging from the tunnel, the want of care as to the changing of the men's wet mining clothes, and the poor character of the food with which the men supplied themselves. All this has been greatly ameliorated, and even in English tunnels certain improvements have been introduced which were brought from Switzerland.

The traffic through the tunnel has so largely increased that the question of ventilation became of pressing importance, and the system of Signor Saccardo, the well-known Government inspector of railways and engineer of Bologna, has been installed, which is an ingenious

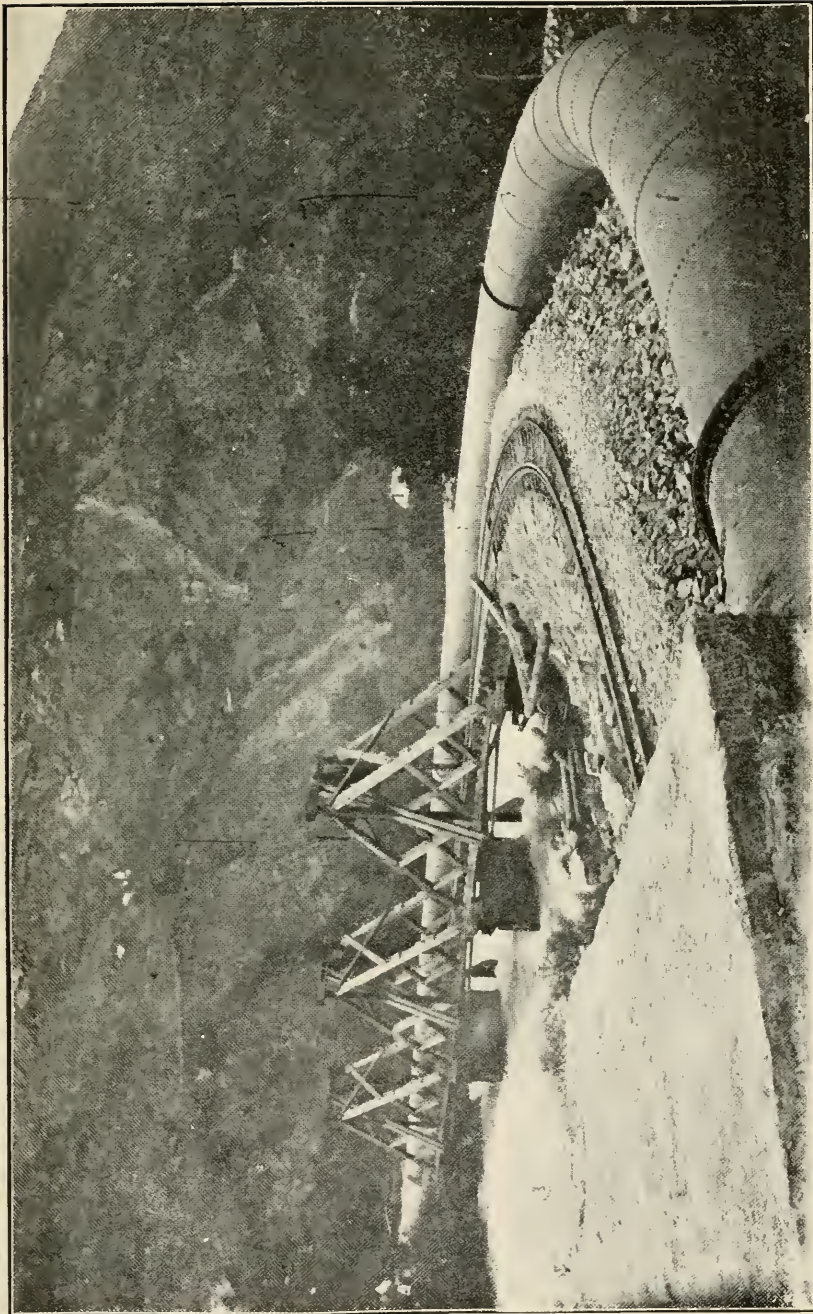

SIMPLON TUNNEL. CROSSING OF THE RHONE BY THE STEEL HYDRAULIC MAIN (3 FEET 3 INCHES DIAMETER), CONDUCTING WATER FROM THE WATER HOUSE TO POWER HOUSE, A DISTANCE OF ABOUT TWO MILES (250 POUNDS PRESSURE PER SQUARE INCH).





application of the injector system. One of the first introductions of this method was in the case of the Pracchia Tunnel, on the main line between Florence and Bologna, through the Apennines. This is a railway of single line, and was built many years ago by the late Mr. Brassey. There are 52 tunnels in all, but those on the eastern side are of comparatively little importance. On the western slope the gradient nearly throughout is 25 per 1,000 (or 1 in 40), and it is here the greatest difficulty exists. There are several tunnels whose lengths approximate to 1,000, 2,000, and 3,000 yards, and the traffic is both heavy and frequent, the locomotives very powerful, with eight wheels coupled.

Under any conditions of wind the state of the longest tunnel is bad,

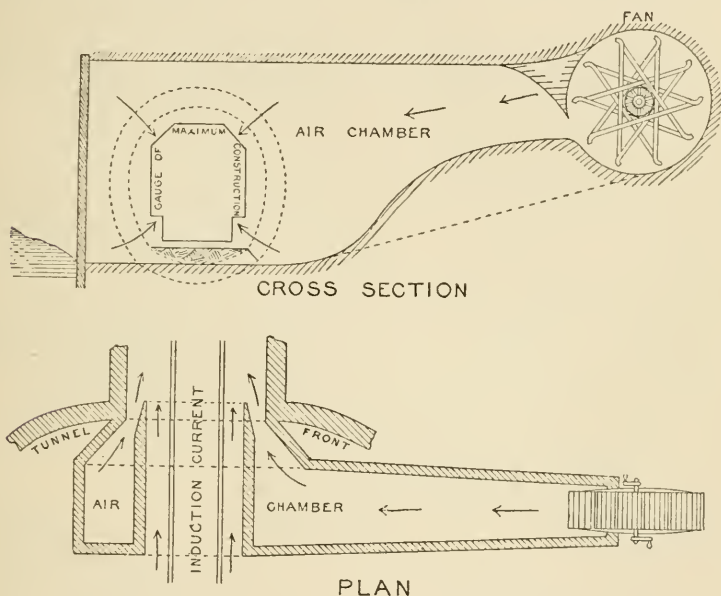

FIG. 6.—The Saccardo system of ventilating tunnels.

but when the wind is blowing in at the lower end at the same time that a heavy goods or passenger train is ascending the gradient a state of affairs is produced which is almost insupportable, and one might as conveniently travel in a furnace flue.

A heavy train of dining and sleeping carriages, with two engines, conveying one of the crowned heads of Europe and suite, arrived at the exit of Pracchia tunnel with both enginemen and both firemen insensible; and in other cases passengers have been seriously affected.

Owing to the height of the mountain, no shafts are available; but Signor Saccardo places a ventilating fan near the mouth of the tunnel and blows air into it through the annular space which exists between the arch of the tunnel and the gauge of maximum construction. (See

fig. 6.) The results are remarkable; the volumes of air thrown into the tunnel per minute being as follows:

	Cubic feet.
Direct from the fan .....	161, 860
Induced draft through open tunnel mouth .....	48, 140
Total .....	210, 000

or 100 cubic meters per second.

The temperature of the tunnel air before the fan was started was 107° F., with 97 per cent of moisture, whereas after the fan had been running a few minutes the temperature was 81° F., or a lowering of 26° F., and the tunnel was cool and free from smoke and vapor.

One can travel through with both windows open and feel no inconvenience, the only remark of the brakeman riding on the top of the wagons and carriages being that he finds it almost too cold.

This application is without doubt the solution of the difficult problem of tunnel ventilation under high mountains and elsewhere where shafts are not available and where electric traction is not applicable.

This system has within the last twelve months been brought into operation on the St. Gothard, with the most satisfactory results. Careful experiments are being made, but there is no doubt that the problem has been solved.

In addition to these tunnels, the Saccardo system has been applied to the Giovi Tunnel, near Genoa—3,300 meters in length—and is being installed on the Giovo Tunnel on the Genoa-Ronco Railway, 8,303 meters in length, besides on some seven other tunnels in Italy, and plans are being prepared for the Mont Cenis.

#### THE SIMPLON TUNNEL.

This tunnel is now in rapid course of construction, the total length of gallery driven up to end of April being as follows:

	Yards.
On the north, or Brigue, side of the Alps .....	3, 228
On the south, or Iselle, side of the Alps .....	2, 350

or over 3 miles in little more than eighteen months, including the necessarily slow progress at the commencement.

The total distance between the two portals will be 21,564 yards, or 12.26 miles. A gallery of direction has been driven at both ends until the actual tunnels are reached, so as to form a directly straight line for the accurate alignment of the work, from end to end.

This great undertaking will consist of two single-line tunnels running parallel one to the other, at a distance apart from center to center of 55 feet 9 inches; and one of the chief features is the much lower altitude of the rails above sea level than any of the other Alpine tunnels. This altitude is at its highest point 2,314 feet, being 1,474 feet lower level than that of the St. Gothard, 1,934 feet lower than that of the

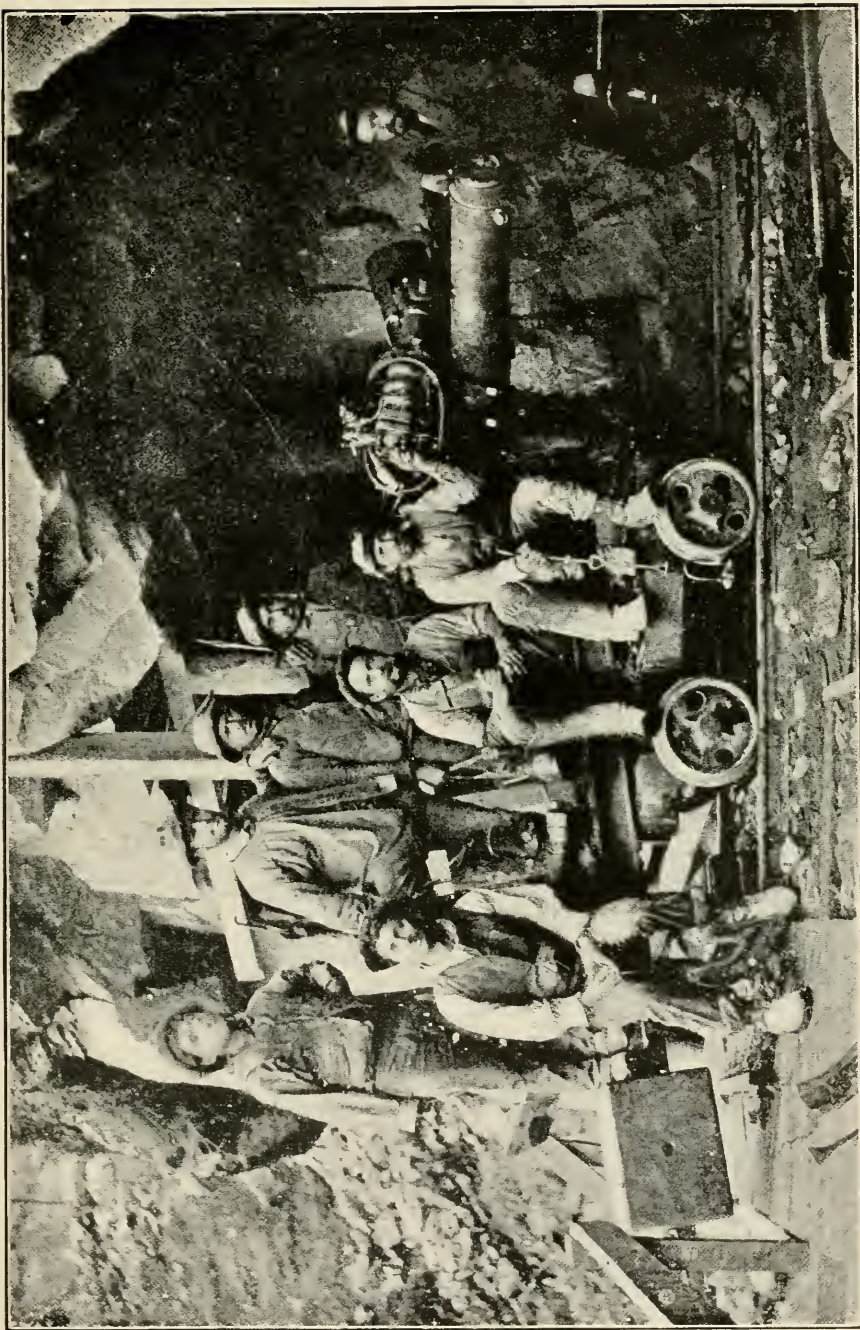

SIMPLON TUNNEL. THE BRANDT HYDRAULIC ROCK DRILL ENTERING TUNNEL WITH ITS GANG OF WORKMEN, SHOWING THE RACK BAR HOLDING THREE SEPARATE BORING MACHINES.



Mont Cenis, and 1,986 feet lower than that of the Arlberg. This is a matter of great importance in the question of haulage of all the traffic.

The tunnel enters the mountain at the present level of the railway at Brigue, so that no costly approaches are requisite on this side; but on the Iselle side, the connecting line with the existing railway at Domo d'Ossola necessitates heavy work with one helical tunnel. The gradient on the northern portion of the tunnel will only be that sufficient for drainage, viz, 1 in 500, but on the southern portion the gradient will be 7 per 1,000, or 1 in 142.

Admirable arrangements have been made for the welfare of the men, to avoid the heavy death rate which occurred on the St. Gothard, and it may be interesting to state what some of these are. For every cubic foot of air sent into the latter tunnel, fifty times as much will be delivered into the Simplon. Special arrangements are made for cooling the air by means of fine jets of water and spray.

The men on emerging from their work, wet through and fatigued, are not allowed to go from the warm headings into the cold Alpine air outside, but pass into a large building which is suitably warmed, and where they change their mining clothes and are provided with hot and cold douche baths. They put on warm dry clothes, and can obtain excellent food at a moderate cost before returning to their homes. Their wet and dirty mining clothes are taken charge of by appointed custodians, who dry and clean them ready for the morrow's work. These and other precautions are expected to reduce the death rate to a very great extent.

With a view to the rapid advancement of the work, the late M. Brandt, whose death is greatly to be deplored, devised after his long experience on the St. Gothard his now well-known drill. As details of this have been published, and as they would be too technical for this evening's discourse, it will only be necessary to refer to them briefly. This drill is nonpercussive, nor is it armed with diamond. It is a rotary drill 3 inches in diameter with a pressure on the cutting points of 10 tons moving at slow speed, but capable of being accelerated at pleasure, and of being rapidly withdrawn. It is armed with a steel tool with 3 cutters, of which samples are on the table. The carriage on which it is mounted enables it to work in any direction. The face of the tunnel is attacked by 10 to 12 holes in the case of the hardest rock, those in the center being 3 feet 3 inches in depth, while those round the circumference are 4 feet 7 inches. The drills are driven by hydraulic pressure of 100 atmospheres, or 1,470 pounds, to the inch, and the cutter having a three-quarter-inch hole along its center, all the waste water is discharged right onto the cutting edges, thus keeping them cool and washing out the débris.

The time taken for each portion of the attack in the hard Antigorio gneiss is as follows: Bringing up and adjustment of drills, twenty

minutes; drilling, one and three-fourths to two and one-half hours; charging and firing, fifteen minutes; clearing away débris, two hours; or a total of between four and one-half to five and one-half hours, resulting in an advance of 3 feet 9 inches, or a daily advance of nearly 19 feet 6 inches.

The progress of each of the two faces during the month of April last has averaged 17 feet  $3\frac{1}{2}$  inches per day, and is a remarkable corroboration of the speed estimated by the engineers four years ago. The estimate was as follows:

Daily progress at each face:	Feet.
First year.....	8.85
Second year.....	17.22
Third year.....	19.18
Fourth year.....	21.32
Fifth year.....	31.16

The work is now in its second year, so that the estimated speed is being exceeded. In other words, the tunnel is being driven through granite at a higher speed than is attained in London clay.

Water power is abundant, and the waters of the Rhone are harnessed to the work, whilst those of the Diveria provide the power at Iselle.

Views are given of the intake from the Rhone, the concrete aqueduct, the metallic conduit pipes, 3 feet, and 3 feet 3 inches in diameter, which carry a pressure of 250 pounds to the inch. The further necessary increase in pressure is obtained by high-pressure pumps in the power house.

It was at one time intended to sink a 20-inch bore hole from the village of Berisal to the tunnel, a depth of some 2,400 feet, for the purpose of delivering water at high pressure for the works. This may still be done, but the meandering of the tool might result in the awkward dilemma of having to search for it, in solid rock, below ground.

Some few years ago a rather amusing incident occurred in connection with a tunnel, which is worth recording. A certain railway company were constructing a tunnel beneath and nearly at right angles to an existing tunnel of one of the large English railway companies. As the legal formalities were not actually completed, the engineers were requested to stay proceedings until all was in order, and they instructed the contractors accordingly, but the latter were anxious not to incur any delay, and they quietly and surreptitiously continued to drive their heading through. The engineer of the existing railway suspected this, and sank a bore hole on the center line of the new work, expecting his tool would, at the correct level, drop into the heading, at a depth of 70 feet. The contractors looked for a similar result, and therefore placed a sheet of steel on the roof of their drift, so that the

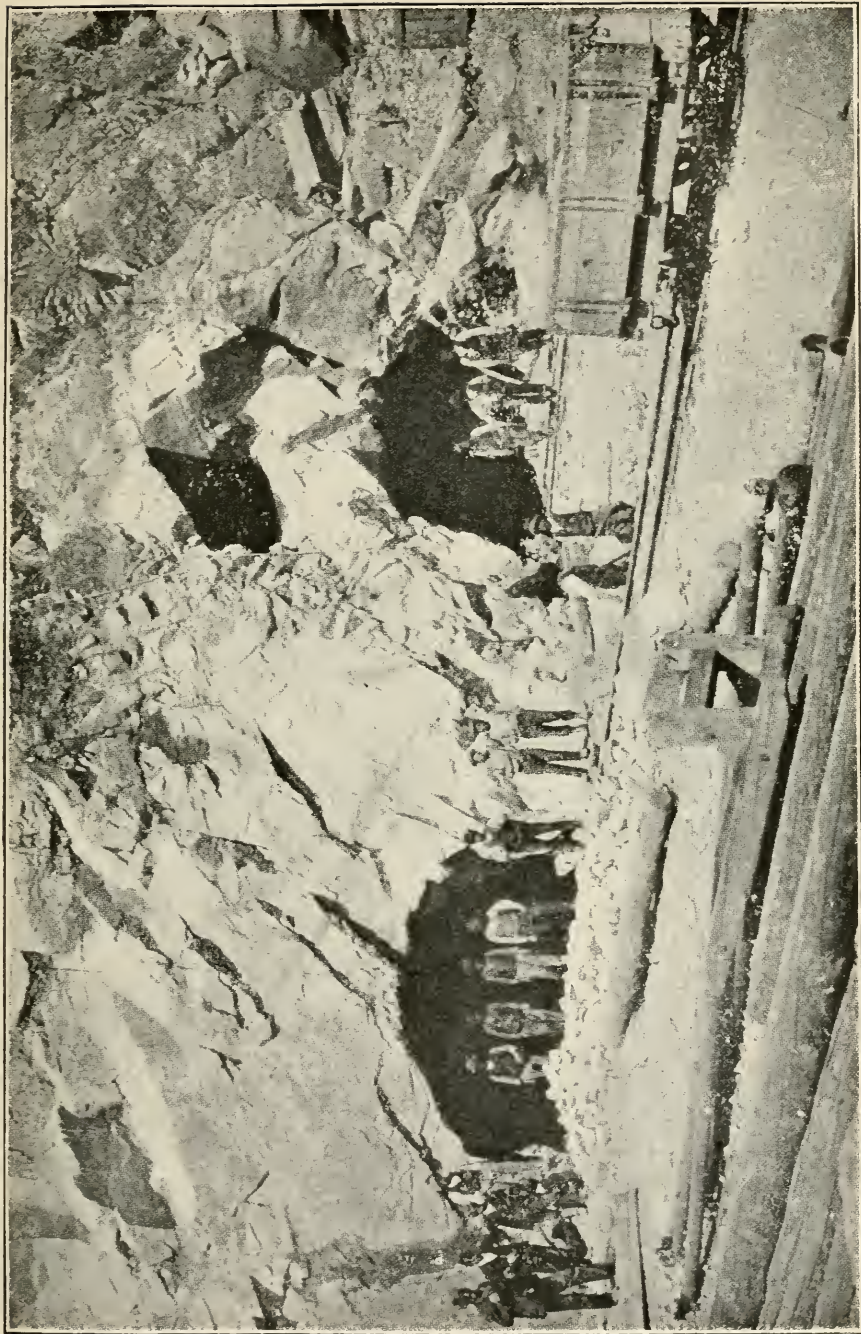

SIMPLON TUNNEL. ENTRANCES OF TUNNELS, ON THE ITALIAN SIDE, IN THE GORGE OF THE DIVERIA, NEAR SELLE.





tool, when it encountered the steel plate, would simply grind away on the top.

But, to the mutual surprise of both the engineer of the existing company and of the contractors for the new work, no drill was encountered, although it had gone to a lower depth than was necessary, some 90 feet. The engineer thereupon lowered, in a foolhardy manner, an explosive charge, and blew in the side of the heading, the tool having meandered several feet to one side. Fortunately no one was hurt, but the engineer was still in ignorance as to what had happened. A bright idea struck him—namely, to lay on the town fire supply of water down the hole to see if he could fill it. The result was, he nearly washed the men away in the heading!

*Electric traction.*—It is desirable to point out how very necessary it may be, in the case of this and other long tunnels, that electric traction should be adopted. Abundant power close at hand already exists; the air of the tunnel would not be vitiated—a matter of great importance where briquette fuel is used—and the rapidity of conducting the traffic would be improved.

In Baltimore an electric locomotive is attached to the through expresses, which takes them through, steam engine and all, at 50 to 60 miles an hour. No stoppage of the express is required at the farther end, the electrical locomotive running ahead into a siding; and some of the very heaviest freight trains, including the locomotive and tender (far heavier than are ever seen in Great Britain), are hauled against a gradient of 1 in 138 at 15 miles an hour.

In fact, in England, we are most lamentably backward in the employment of electricity, and unless the central and the local authorities can be aroused from their lethargy, and from their opposition to all such enterprises, England will continue to lag in the rear of other nations, instead of, as in past years, teaching them a more perfect method.

In conclusion, may I ask for the sympathy, may more, for a silent prayer on behalf of our tunnel and railway heroes, when we are passing along some of the great railway works of the country or of the world.

Need I refer to that young resident engineer who, when a length of a certain tunnel during construction through quicksand fell in, burying 11 men, volunteered at the risk of his life, in consequence of the men being panic-stricken, to go down the shaft and rebuild the damaged work with his own hands and alone? And to that ganger who, having held back for a time, seeing that the engineer was determined to do the work, jumped into the bucket with some strong language to the effect "that he wouldn't see the master killed alone," and went down, and they two completed the next length before the men would return to work.

There are heroes on our railways as there are in our army and navy, and they deserve better recognition. May I plead on behalf of our inspectors and superintendents of our great railway stations, who are in many cases almost worked to death, and yet have to be attentive and courteous to all; albeit, except in certain honorable exceptions, they are unable to make proper provision for old age? And should it be necessary for a station master, after six years' work at a great railway junction, to drop into his grave with the simple epitaph "tired out?"

## THE MUTATION THEORY OF PROFESSOR DE VRIES.

By CHARLES A. WHITE.

During the sixth and seventh decades of the century just closed there occurred so great a change in methods of scientific thought and practice among biologists that it may be properly designated as a revolution. It was caused mainly by the writings of Charles Darwin, in which he promulgated his theory of the evolutionary origin of species by natural selection. No theory pertaining to natural science ever called forth more bitter and uncompromising controversy among both scientists and the people at large, and none was ever more earnestly advocated. Some naturalists eagerly accepted it for all, and even more than, the author claimed for it; but some of the older and ablest of those students of nature were then willing to accept it only as a working hypothesis. Although it has necessarily always remained purely a theory, unsupported by any practical demonstrations or experimental observations, it explained so many things pertaining to the genesis of organic forms as natural phenomena, and explained them so much better than had ever been done before, that during the last quarter of a century the Darwinian theory may be said to have had universal acceptance. Still, there has not been wanting from time to time the expression of more or less plausible, and even valid, objections to portions of that theory on the part of sincere and able naturalists, of which all honest investigators have taken due cognizance.

None of the objections referred to, however, has hitherto seemed to materially modify the prevailing confidence in the Darwinian theory, which confidence has doubtless been increased by the powerful influence which that theory has exerted in the adoption of evolutionary methods in the study of all branches of natural as well as of social science. Still, a revulsion of opinion concerning all mere theories is always liable to occur, and while no true naturalist will ever desire the least diminution of the fame of Darwin, and none will ever abandon the fundamental principles of evolution, it is not improbable that the now prevailing estimation of his theory of the origin of species by natural selection will eventually be modified in some important respects. In the course of the year 1901 there was published in the German language the first volume, in separate parts, of an exhaustive work<sup>a</sup> which is evidently

<sup>a</sup>Die Mutationstheorie. Versuche und Beobachtungen über die Entstehung von Arten im Pflanzenreich. Von Hugo de Vries. Leipzig, 1901.

destined to make a strong impression of that kind upon biologists because of its eminently scientific presentation, and because it promulgates a theory of the origin of species by mutation that is in material disagreement with the Darwinian theory of their origin by natural selection. The work is to consist of two volumes, the second of which will probably not be fully published before the end of 1902. The mutation theory therein enunciated, however, has been foreshadowed in previous lesser publications by the same author, it is so fully stated in the already published parts of the present work, and is so remarkable in its character, that it is thought proper to present a brief statement of its leading features at this time.

The subject-matter of this work is arranged under two principal heads for the two volumes, respectively, namely, "The Origin of Species by Mutation," and "Elementary Hybridity." Necessarily, only the first volume can now be considered, but that contains the only part which I should care to discuss at the present time, even if the other volume were now published. In fact, I shall discuss only that portion of Volume I which contains the formal exposition of the mutation theory. The author presents his subject strongly and unequivocally, but with evident candor and sincerity of purpose and after long and patient investigation. As I wish to give the author's views of his mutation theory as far as possible in the English equivalent of the language used by him, the following quotations are selected alternately and translated from the author's preface, introduction, and text, respectively:

"The doctrine of the origin of species has hitherto been a conventional science. It is generally believed that this important occurrence is withdrawn from actual observation, or at least from experimental treatment. This conviction is founded upon the prevailing conception concerning specific characters and upon the opinion that species of plants and animals are always produced from one another by extremely slow degrees. It is thought that these metamorphoses are so slow that a human life is not long enough to witness the production of a new form. The purpose of the present work is to show the opposite view—that species originate by sudden starts, and that each one of these saltatory occurrences is, as good observations show, a true physiological process; that all such suddenly produced forms are separated from one another by at least as sharp and numerous characters as are most of the so-called minor species, and as are many of the nearly related forms of the best systematists. It is thus made possible to learn by means of actual observation, cultivation, and experiment the laws which govern the production of new species. These laws are evidently as applicable to animals as to plants. As a botanist, I have confined myself to the latter, but in the confident hope that my results will later be also employed in the study of animals.

"The whole subject of variability falls under two heads—variability in the narrow sense and mutation. The first is variously designated as common, individual, and fluctuating, or gradual variability. Mutation forms a special division of the methods of variation. It does

not occur flowingly, but in steps, without transition, and it occurs less frequently than do the common variations, which are continuously and constantly at hand. The contrast between the two kinds at once appears if one considers the proposition that the attributes of organisms are built up of fixed and sharply defined units. These units combine in groups, and in the kindred of species the same units and groups are reproduced. The origination of a new unit signifies a mutation. Every addition of a unit to a group constitutes a step, originates a new group, and separates the new form sharply and fully as an individual species from the one out of which it has been produced. The new species is at once such, and originates from the former species without apparent preparation and without gradation. Each attribute, of course, arises from one previously present, not by their normal variation, but by one small yet sudden change. Provisionally, one may compare these changes, but only in the simplest manner, with chemical substitution.

“In the first section of this book the mutation theory is contrasted with the selection theory. The latter assumes the common variability to be the starting point of the origin of a new species, but according to the mutation theory the two processes are quite independent of each other. Common variability, as I hope to show, does not lead, by even the sharpest persistent selection, to any real transgression of the limits of species, much less to the origin of new and constant attributes.”

It is in the first section of Volume I that the author discusses at length selection and mutation, mutability and variability, all the various theories of evolution that have been proposed, the effects of climate and of horticultural breeding, the limitations and characteristics of species and varieties, and other pertinent subjects. He concludes that section of the volume with the following summary concerning the nature of his theory:

“(1) The doctrine of morphological and historical descent deals with the origin of the Linnean, or collective species, the genera, families, and higher groups. The doctrine of experimental descent deals with the origin of elementary species, or, more strictly speaking, with the origin of specific characters.

“(2) ‘The true danger reef of the Darwinian theory is the transition from artificial breeding selection to natural selection.’ (Paul Janet.) This reef can only be avoided when one recognizes the improvement of races and the origination of new forms as two entirely different occurrences, only apparently passing into each other. For Darwin, they stand side by side, the one in no way excluding the other, although, as a rule, he has not sharply differentiated them.

“(3) ‘No two individuals of any planting are entirely alike.’ This well-known proposition is to be confined to the province of real fluctuating variability. It stands in no relation to the doctrine of descent, if one accepts the mutation theory.

“(4) ‘Species have originated by natural selection in the struggle for existence.’ But this statement needs explanation. The struggle for existence—that is, competition for existence—embraces two entirely different points. Whenever the contest occurs between individuals of one and the same elementary species, it also occurs between the different species as such. The first-mentioned contest pertains to the

doctrine of variability, the second to that of mutation. In the first-mentioned case those individuals survive which find their life conditions most favorable, and they are therefore generally the most vigorous. By this process local races originate, and by it acclimatization is made possible. If the new life conditions cease, then the adapted races revert to the original type.

“Natural selection in the struggle for existence between the newly originated elementary species is quite different. These originate suddenly, unmediated, and multiply themselves if nothing stands in the way, because they are for the most part completely, or in a high degree, heritable. If, then, the increase leads to a struggle for existence, the weaker succumb and are rooted out. According as the older or the younger form happens to be the better suited for the life conditions will one or the other survive. By this struggle for existence species are no more likely to originate than they are by the struggle between the variants of one and the same type, but evidently from quite a different cause. To be able to come into competition with one another, species must exist. The contest decides which of them shall survive and which shall perish. These ‘species selections,’ in the course of their evolution, have, without doubt, rooted out immense numbers and retained only a small proportion. Briefly stated, I assert, of course on the ground of the mutation theory, that by the struggle for existence and by natural selection species do not originate, but perish.

“(5) Herbert Spencer’s well-known expression, ‘the survival of the fittest,’ is of course divisible into two propositions: The survival of the fittest individuals within the constant species, or the formation of local races, and the survival of the fittest species as the foundation of the doctrine of descent. The two propositions are independent of each other and belong to different categories.

“(6) According to the mutation theory, species have not originated by gradual selection, continued through hundreds or thousands of years, but by sudden steps, even if the changes are very small. Unlike the variations, which are progressive changes in a direct line, those metamorphoses which are designated as mutation branch off in new directions. Furthermore, so far as experience goes, they occur at random—that is, in the most diverse directions. They appear only from time to time, and then probably under the operation of determinate causes.”

It should be borne in mind that throughout this work the author always restricts the term “mutation” to the designation of sudden phylogenetic changes, which he distinguishes sharply from all forms of mere variation, however pronounced they may be, and also that in the following remarks I also use that term in the same restricted sense. The horticultural forms of variation are especially discussed in the closing section of Volume I.

The second section of Volume I is entitled “The origination of elementary species in the genus *Cenothera*,” and constitutes its larger part. It consists of an elaborate statement, with numerous illustrations, of the author’s experimental studies of the subject of mutation which he instituted in a systematic manner in 1886, and which he has

pursued uninterruptedly ever since. It appears that his first and guiding proposition in connection with his experimental work was that, in the different periods of their chronological life history, all plants vary greatly in the ratio of their mutability; that is, all species and genera, while they are always subject to the full range of fluctuating variability, exist at times in a mutable and at times in an immutable condition, the latter condition being much the more prevalent. Indeed, so prevalent is the immutable condition among plants that only a small proportion of the species embraced in the flora of any given region may be found existing in their mutable period. Furthermore, it was to be expected that some plants, even when in the fullness of their mutable period, would exhibit their mutability more readily than others. The germ of this theory is contained in the author's little book on intracellular pangenesis,<sup>a</sup> written just before he began his experiments, wherein he gives the reasons which led him to believe in mutability. His experimental studies here referred to were undertaken for the purpose of discovering mutating plants and of demonstrating his theory upon them.

Professor de Vries's first effort was therefore toward the selection of suitable plants for his experimental studies from the flora, both native and introduced, which he found growing in the northern part of Holland. For that purpose he placed under special cultivation in experimental gardens at Amsterdam more than one hundred species of plants, and prosecuted his preliminary experiments upon them. This special cultivation was not for the purpose of producing horticultural variation in those plants, but for the purpose of protecting and aiding such of them as should prove to be in their mutative period.

At the same time he also made numerous observations upon many other plants in their natural habitat, with the same object in view. The result of these preliminary experiments was that the so-called Evening Primroses were found to respond more readily to mutative influences than would any of the other species that came under his observation. These are American species of plants, of the genus *Enothera*, that had been introduced into Holland, where they thrived like native plants, both under cultivation and in a wild state. About the year 1875 one of them, *O. Lamarckiana*, began a most vigorous multiplication and dispersion, especially from a center near the town of Hilversum. This unusual exhibition of generative and dispersive force was apparently correlated with the mutative impulse, for there soon appeared among those plants two distinct species of *Enothera* that were before unknown, although the flora of that and other regions had long passed under the severe scrutiny of Professor de Vries and other able botanists. The inference seemed to be legitimate that those plants were then in the full vigor of their mutative period, and that the

<sup>a</sup> See Intracellulare Pangenesis; pp. 212. von Hugo de Vries. Jena, 1889.

two species referred to originated from them then and there by spontaneous mutation. The latter inference accords with the author's proposition, that in their wild condition mutating plants produce many new species; that most of these perish in the struggle for existence, and that artificial cultivation protects all the new forms from destruction, but is not of itself the cause of the origination of any.

It seems to have been this exhibition of mutative vigor in the Evening Primroses that led its distinguished observer to adopt those plants as the chief subjects of his experimental studies, and it is for this reason that so large a part of his book is devoted to the exhaustive exploitation of plants belonging to the genus *Oenothera*. The results plainly show the wisdom of that choice, for by careful protection and the aid of artificial pollination he succeeded in obtaining from them a considerable number of new species, which are as well defined in all their attributes as are any of the other species of that genus. Moreover, he continued from year to year his experiments with the new species thus produced, as well as with the original forms, and he asserts without hesitation that in all their attributes the new forms are not only sharply defined but that those attributes are entirely constant from and after the moment of their origin; and, furthermore, that all those attributes are as heritable as are those of any of the other species. He practiced both inter and intra specific artificial pollination, but, although he obtained the reproduction of some of the new forms under the former method, the origination of species *de novo* under his experiments seems to have been wholly by aid of the latter method; that is, his experiments seem to prove that cross fertilization is not only not necessary to mutation, but that mutation is not materially accelerated by it. It is well known that some authors claim that thousands of species of living plants have originated by hybridization. The second volume will treat fully of that subject and of its relation to true mutation.

The author supports all his statements with the most minute account of his experiments, the results of which he also discusses fully. These facts and discussions are of such a character that it seems difficult to see how one can avoid accepting his conclusions without denying his facts. Indeed, it may be frankly stated that should one accept his conclusions the author will be thereby recognized as not only the propounder of a new and important biological theory, but the discoverer of new and vital facts and principles relating to the origination and perpetuation of organic forms. Furthermore, by accepting that theory and admitting the facts upon which it is based, one must necessarily regard the question of the origin of species as thereby removed from the purely theoretical to the concrete; that is, from an undemonstrable hypothesis to a series of concrete propositions and practical demonstrations. These are strong statements, but they indicate what one



must be prepared to admit who accepts the proposed mutation theory. I may add that for reasons which I will state further on I am much inclined to view this theory with favor, but the affirmative manner in which I present this sketch of it may be regarded as indicating my purpose to discuss the subject from the author's standpoint.

This theory does not require that one should go back to the view held by devout naturalists before Darwin's time, that species are categories of creative thought in the Divine mind, but it does require that one shall regard species as having a more real entity than he has been accustomed to conceive of in connection with the theory of natural selection. Professor de Vries expressly claims that mutation, although suddenly accomplished, is strictly a physiological process, coincident in its incipient manifestation with the function of reproduction. It is therefore plain that his theory does not in any way oppose the fundamental fact of evolution, but offers a new theoretical explanation of the method of its accomplishment.

Considering the completeness and success of the experimental studies made by Professor de Vries with *Enothera*, one naturally infers that other plants also now exist in the fullness of their mutative period, and that these would yield similar results under similar treatment. Perhaps, also, certain species which are immutable in some regions will be found to be mutable in others. Indeed, results that evidently belong in the same category with those obtained by Professor de Vries have, from time to time, been obtained by naturalists and horticulturists from various plants, but those cases have not hitherto received the interpretation that will be given to them by the mutation theory, although they were known to be incompatible with the theory of natural selection. I have lately recorded a case of this kind,<sup>a</sup> and several others have more or less fully engaged my personal attention.

Professor de Vries is confident that his theory is as applicable to animals as to plants, and that conclusion is plainly a logical one; but he makes no suggestion as to methods of experimental studies of that kind, and I can make none. I have, however, in my paleontological studies, been often confronted with facts with relation to both animal and vegetable fossil forms that seem to be quite inconsistent with the theory of their origin by the slow process of natural selection. Demonstrations of the truth of the mutation theory must, of course, always be made with living organisms, but as much of its support must doubtless come from apriori reasoning, especially with reference to extinct organic forms, I will close by mentioning a few of the many paleontological facts referred to. These seem to relate with peculiar force to the primary proposition of the mutation theory, that all species have originated from one another suddenly, and not by slow degrees; and, also, to two of its secondary propositions. The first of these two is,

<sup>a</sup> See "Science," Vol. XVI, n. s., Nov. 29, 1901, pp. 841-844.

that the mutation theory is as applicable to animals as to plants, and the second, that the ratio of the mutability of species and, by implication, also, of the higher groups, varies in the course of their chronological life history. It is necessary to mention here that according to the mutation theory each newly originated species, while possessing distinctly separate attributes, is never very widely different from the parent form. Wide differences result from the extinction of intervening species and repeated mutations; and because newly mutated species may themselves be immediately mutative, wide differences may occur in a comparatively short time. This view of the subject has an important bearing upon the following remarks.

The earliest known fossil faunas, those of the Cambrian age, embrace remains representing five of the six animal subkingdoms, namely, the Protozoa, Cœlenterata, Annuloida, Annulosa, and Mollusca. Furthermore, these fossil remains indicate a high degree of faunal development, and proportionately wide differentiation in each of those subkingdoms. That is, fossil remains of well-developed faunas pertaining to all the animal subkingdoms, except the Vertebrata, are found in the earliest known fossiliferous strata of the earth; and the occurrence of remains pertaining to those five subkingdoms in all subsequent subdivisions of the geological scale shows that their genetic lines have come down without a break to the present day. We know absolutely nothing of any earlier life than that represented by those Cambrian forms; and we must assume their sudden, or at least rapid, origination, or, by applying the theory of natural selection, construct an evolutionary parallax that, by its inconsiderable angle, will carry back the origin of life upon the earth to a chronological point inconceivably remote. It therefore seems unreasonable to apply the theory of natural selection to this case.

The wonderful flora of the Carboniferous age stands out prominent and unique from all the other known floras of the earth, and yet we know little or nothing of its ancestry or of its genetic succession. Its introduction and extinction were apparently too sudden and complete to be satisfactorily explained by the theory of natural selection.

The earliest known remains of the great subclass of dinosaurian reptiles are found in the earlier Mesozoic strata, and the latest known representatives of that subclass barely survived the close of Mesozoic time. Those earliest dinosaurs existed in multitudes, and suddenly became the ruling animals of the earth. A large proportion of them were of titanic size, and the grade of their organization was of the highest of their class. They were differentiated into flesh eaters and plant eaters and into denizens of land and water respectively. We know absolutely nothing of their genetic origin; but their introduction upon the earth was evidently so sudden and their differentiation so great and various that the theory of natural selection is plainly insufficient

to explain it. Furthermore, one can by no means feel confident that the utter extinction of that great subclass was due to what has come to be designated as the struggle for existence, because before that occurrence it had long ruled the animal life of the earth and was apparently able to maintain its supremacy both upon land and water.

In the earlier Mesozoic strata remains of fresh-water molluscan faunas are found that contain distinctly modern types. Among them are species of the true genus *Unio*, which is one of the most widely dispersed and characteristic fresh-water genera now living, and remains of species belonging to it are found in other fresh-water deposits of both Mesozoic and Tertiary age. That genus has therefore existed continuously and unchanged during all that stretch of geological time in which all the mammals, all the birds, all the teleost fishes, and all the exogenous plants of the earth were introduced and in which the dinosaurs culminated and became extinct. Those earliest known specimens of the genus *Unio* are fully characteristic, but we know nothing whatever of their origination or of any earlier related forms. It seems impossible to assume that this genus was not suddenly produced, and it seems equally evident that upon its introduction it passed at once into its immutable state, which has continued until now, at least in a main line.

The case seems to have been very different with other forms of animal life that are now extinct, especially with the placental mammals. These apparently had no existence before the beginning of Tertiary time, but they then suddenly appeared and assumed faunal dominion of the earth in forms nearly or quite as highly organized and diverse as are those which now exist; but every one of those earlier mammalian forms, with many others of later origin, are now extinct. The mutative period of each of those forms was probably coeval with at least the greater part of its faunal existence, and it seems necessary to assume that the origination of all of them was of a rapid, if not saltatory character. The case of these mammals, on the one hand, and that of the fresh-water mollusca that have been mentioned, on the other, may be taken as extreme examples of the difference in the chronological ratio of phylogenetic mutation among organic forms that existed in geological time.

Not only the placental mammals, but the birds of modern types, the teleost fishes, and the exogenous plants, were also introduced with an apparent suddenness that is inconsistent with the theory of natural selection. It is true that the foreshortened view which we necessarily get by looking back into geological time may make the periods in which those evolutionary changes took place appear shorter than they really were, but a different view would not change the proportional elements of the problem.

One of the strongest arguments that have been used in support of

the assumed extreme antiquity of the habitable condition of the earth has been drawn from the theory of the origination of organic forms by the slow process of natural selection. Indeed such extreme antiquity has been assumed expressly to meet the demands of that theory. A general acceptance of the mutation theory will remove that question from such discussions, and geological science would probably not suffer by the loss.

The great master, Darwin, in one of his aphorismic utterances, says that in "scientific investigations it is permitted to invent any hypothesis, and if it explains various large and independent classes of facts it rises to the rank of a well-grounded theory." One can not doubt that if he were now living he would be among the first to give the mutation theory respectful consideration.

Whatever the final verdict of biologists may be concerning the theory that Professor de Vries has so elaborately proposed, the subject is so important and the presentation is so carefully made that no student of any branch of biology can afford to ignore it.

## THE DINOSAURS OR TERRIBLE LIZARDS.<sup>a</sup>

By F. A. LUCAS.

“Shapes of all sorts and sizes, great and small.”

A few million years ago, geologists and physicists do not agree upon the exact number, although both agree upon the millions, when the Rocky Mountains were not yet born and the now bare and arid Western plains a land of lakes, rivers, and luxuriant vegetation, the region was inhabited by a race of strange and mighty reptiles upon whom science has bestowed the appropriate name of Dinosaurs, or terrible lizards.

Our acquaintance with the Dinosaurs is comparatively recent, dating from the early part of the nineteenth century, and in America, at least, the date may be set at 1818, when the first Dinosaur remains were found in the valley of the Connecticut, although they naturally were not recognized as such, nor had the term been devised. The first Dinosaur to be formally recognized as representing quite a new order of reptiles was the carnivorous Megalosaur, found near Oxford, England, in 1824.

For a long time our knowledge of Dinosaurs was very imperfect and literally fragmentary, depending mostly upon scattered teeth, isolated vertebrae, or fragments of bone picked up on the surface or casually encountered in some mine or quarry. Now, however, thanks mainly to the labors of American palaeontologists, thanks also to the rich deposits of fossils in our Western States, we have an extensive knowledge of the Dinosaurs, of their size, structure, habits, and general appearance.

There are to-day no animals living that are closely related to them; none have lived for a long period of time, for the Dinosaurs came to an end in the Cretaceous, and it can only be said that the crocodiles, on the one hand, and the ostriches, on the other, are the nearest existing relatives of these great reptiles.

For, though so different in outward appearance, birds and reptiles are structurally quite closely allied, and the creeping snake and the

<sup>a</sup> Reprinted, with the accompanying illustrations, by permission of McClure, Phillips & Co., from *Animals of the Past*.

bird on which it preys are relatives, although any intimate relationship between them is of the serpent's making, and is strongly objected to by the bird.

But if we compare the skeleton of a Dinosaur with that of an ostrich—a young one is preferable—and with those of the earlier birds, we shall find that many of the barriers now existing between reptiles and birds are broken down, and that they have many points in common. In fact, save in the matter of clothes, wherein birds differ from all other animals, the two great groups are not so very far apart.

The Dinosaurs were by no means confined to North America, although the western United States seem to have been their headquarters, but ranged pretty much over the world, for their remains have been found in every continent, even in far-off New Zealand.

In point of time they ranged from the Trias to the Upper Cretaceous, their golden age, marking the culminating point of reptilian life, being in the Jurassic, when huge forms stalked by the seashore, browsed amid the swamps, or disported themselves along the reedy margins of lakes and rivers.

They had their day, a day of many thousand years, and then passed away, giving place to the superior race of mammals which was just springing into being when the huge Dinosaurs were in the heyday of their existence.

And it does seem as if in the dim and distant past, as in the present, brains were a potent factor in the struggle for supremacy; for, though these reptiles were giants in size, dominating the earth through mere brute force, they were dwarfs in intellect.

The smallest human brain that is thought to be compatible with life itself weighs a little over 10 ounces, the smallest that can exist with reasoning powers is 2 pounds; this in a creature weighing from 120 to 150 pounds.

What do we find among Dinosaurs? *Thespesius*, or *Claosaurus*, which may have walked where Baltimore now stands, was 25 feet in length and stood a dozen feet high in his bare feet, had a brain smaller than a man's clenched fist, weighing less than 1 pound.

*Brontosaurus*, in some respects the biggest brute that ever walked, was but little better off, and *Triceratops* and his relatives, creatures having twice the bulk of an elephant, weighing probably over 10 tons, possessed a brain weighing not over 2 pounds.

How much of what we term intelligence could such a creature possess—what was the extent of its reasoning powers? Judging from our own standpoint and the small amount of intellect apparent in some humans with much larger brains, these big reptiles must have known just about enough to have eaten when they were hungry; anything more was superfluous.

However, intelligence is one thing, life another, and the spinal cord

with its supply of nerve substance doubtless looked after the mere mechanical functions of life; and while even the spinal cord is in many cases quite small, in some places, particularly in the sacral region, it is subject to considerable enlargement. This is notably true of *Stegosaurus*, where the sacral enlargement is twenty times the bulk of the puny brain—a fact noted by Professor Marsh, and seized upon by the newspapers, which announced that he had discovered a Dinosaur with a brain in its pelvis.

In their great variety of size and shape the Dinosaurs form an interesting parallel with the Marsupials of Australia. For just as these are, as it were, an epitome of the class of mammals, mimicking the herbivores, carnivores, rodents, and even monkeys, so there are carnivorous and herbivorous Dinosaurs—Dinosaurs that dwelt on land and others that habitually resided in the water, those that walked upright and those that crawled about on all fours; and, while there are no hints that any possessed the power of flight, some members of the group are very bird-like in form and structure, so much so that it has been thought that the two may have had a common ancestry.

The smallest of the Dinosaurs whose acquaintance we have made were little larger than chickens; the largest claim the distinction of being the largest known quadrupeds that have walked the face of the earth, the giants not only of their day, but of all time, before whose huge frames the bones of the Mammoth, that familiar byword for all things great, seem slight.

For *Brontosaurus*, the thunder lizard, beneath whose mighty tread the earth shook, and his kindred were from 40 to 60 feet long and 10 to 14 feet high, their thigh bones measuring 5 to 6 feet in length, being the largest single bones known to us, while some of the vertebræ were  $4\frac{1}{2}$  feet high, exceeding in dimensions those of a whale.

The group to which *Brontosaurus* belongs, including *Diplodocus* and *Morosaurus*, is distinguished by a large, though rather short, body, very long neck and tail, and, for the size of the animal, a very small head. In fact, the head was so small and, in the case of *Diplodocus*, so poorly provided with teeth that it must have been quite a task, or a long-continued pleasure, according to the state of its digestive apparatus, for the animal to have eaten its daily meal.

An elephant weighing 5 tons eats 100 pounds of hay and 25 pounds of grain for his day's ration; but, as this food is in a comparatively concentrated form, it would require at least twice this weight of green fodder.

It is a difficult matter to estimate the weight of a live *Diplodocus* or a *Brontosaurus*, but it is pretty safe to say that it would not be far from 20 tons, and that one would devour at the very least something over 700 pounds of leaves or twigs or plants each day—more, if the animal felt really hungry.

But here we must, even if reluctantly, curb our imagination a little and consider another point: The cold-blooded, sluggish reptiles, as we know them to-day, do not waste their energies in rapid movements, or in keeping the temperature of their bodies above that of the air, and so by no means require the amount of food needed by more active, warm-blooded animals. Alligators, turtles, and snakes will go for weeks, even months, without food, and while this applies more particularly to those that dwell in temperate climes and during their winter hibernation practically suspend the functions of digestion and respiration, it is more or less true of all reptiles. And as there is little reason for supposing that reptiles behaved in the past any differently from what they do in the present, these great Dinosaurs may, after all, not have been gifted with such ravenous appetites as one might fancy. Still, it is dangerous to lay down any hard and fast laws concerning animals, and he who writes about them is continually obliged to qualify his remarks—in sporting parlance, to hedge a little, and in the present instance there is some reason, based on the arrangement of the vertebrae and ribs, to suppose that the lungs of Dinosaurs were somewhat like those of birds, and that, as a corollary, their blood may have been better aerated and warmer than that of living reptiles. But to return to the question of food.

From the peculiar character of the articulations of the limb bones it is inferred that these animals were largely aquatic in their habits, and fed on some abundant species of water plants. One can readily see the advantage of the long neck in browsing off the vegetation on the bottom of shallow lakes, while the animal was submerged, or in rearing the head aloft to scan the surrounding shores for the approach of an enemy. Or, with the tail as a counterpoise, the entire body could be reared out of water and the head be raised some 30 feet in the air.

Triceratops, he of the three-horned face, had a remarkable skull which projected backward over the neck, like a fireman's helmet, or a sunbonnet worn hind side before, while over each eye was a massive horn directed forward, a third, but much smaller horn being sometimes present on the nose.

The little "horned toad," which isn't a toad at all, is the nearest suggestion we have to-day of Triceratops; but, could he realize the ambition of the frog in the fable and swell himself to the dimensions of an ox, he would even then be but a pigmy compared with his ancient and distant relative.

So far as mere appearance goes he would compare very well, for while so much is said about the strange appearance of the Dinosaurs, it is to be borne in mind that their peculiarities are enhanced by their size, and that there are many lizards of to-day that lack only stature to be even more bizarre; and, for example, were the Australian Moloch



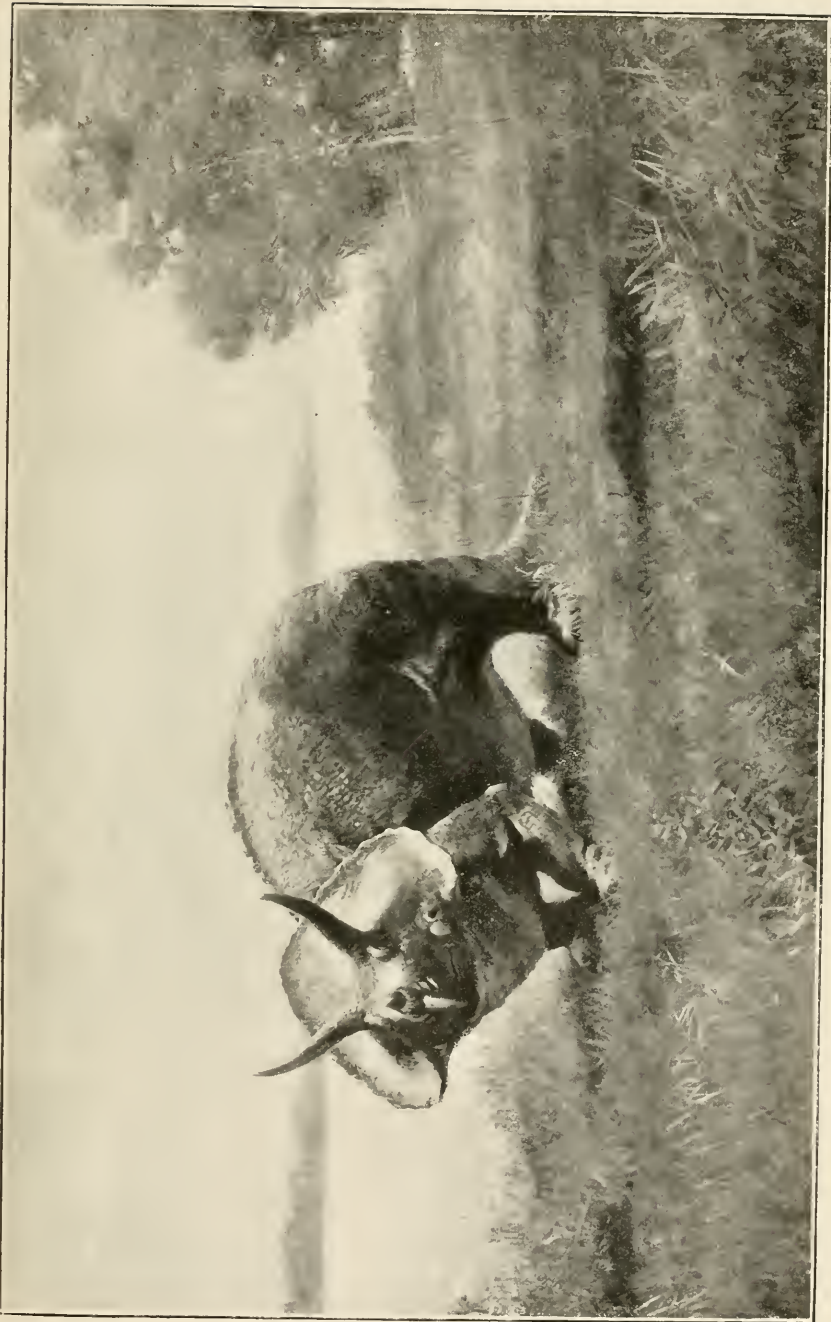

TRICERATOPS—HE OF THE THREE-HORNED FACE.

From a painting by C. R. Knight.





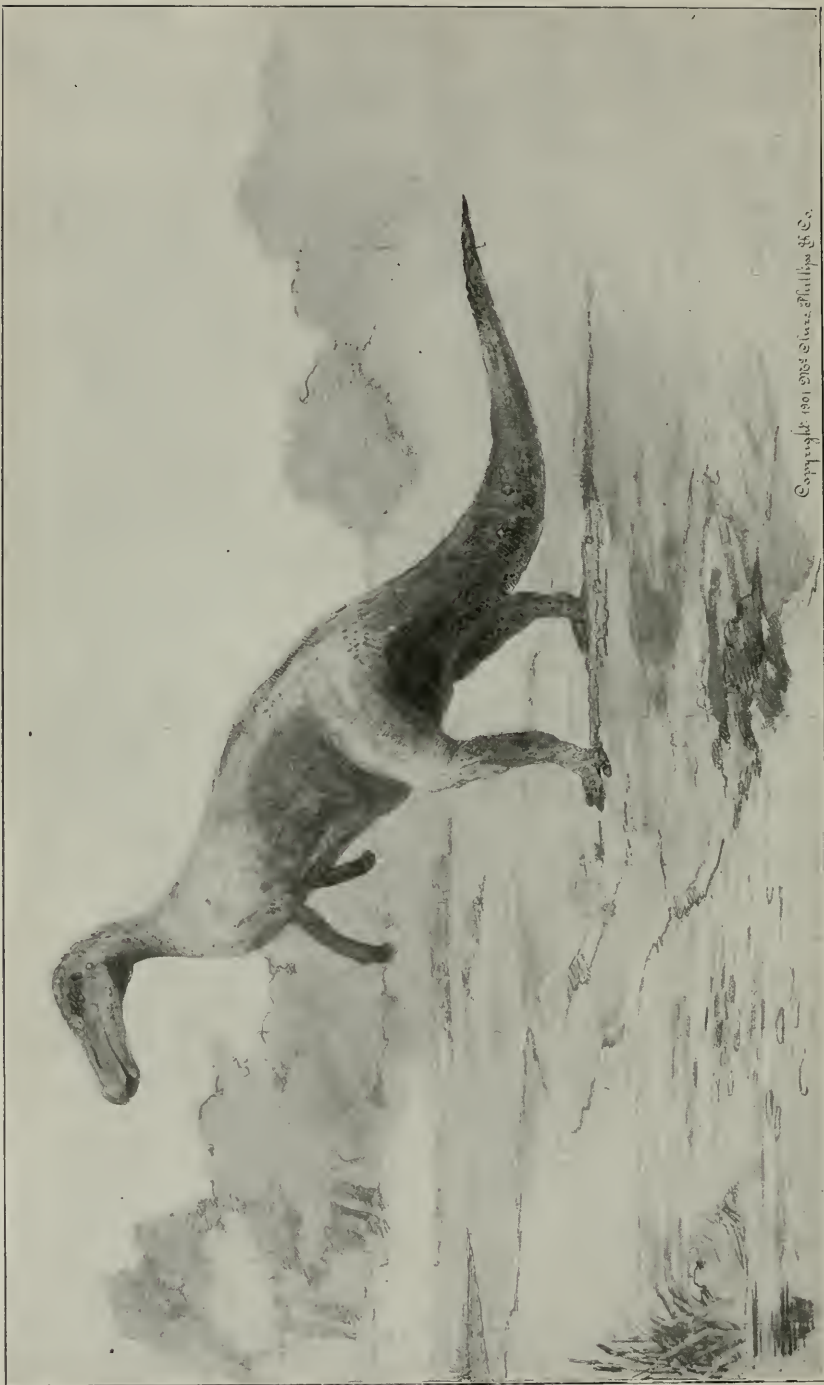

Copyright 1901 by C. R. Knight & Co.

Copyright, McClure, Phillips & Co.

**THESPESIOUS, A COMMON CRETACEOUS DINOSAUR.**

From a drawing by C. R. Knight.

but big enough, he could give even *Stegosaurus* "points" in more ways than one.

Standing before the skull of *Triceratops*, looking him squarely in the face, one notices in front of each eye a thick guard of projecting bone, and while this must have interfered with vision directly ahead it must have also furnished protection for the eye. So long as *Triceratops* faced an adversary he must have been practically invulnerable, but as he was the largest animal of his time, upward of 25 feet in length, it is probable that his combats were mainly with those of his own kind and the subject of dispute some fair female upon whom two rival suitors had cast covetous eyes. What a sight it would have been to have seen two of these big brutes in mortal combat as they charged upon each other with all the impetus to be derived from ten tons of infuriate flesh! We may picture to ourselves horn clashing upon horn, or glancing from each bony shield until some skillful stroke or unlucky slip placed one combatant at the mercy of the other, and he went down before the blows of his adversary "as falls on Mount Alverna a thunder-smitten oak."

A pair of *Triceratops* horns in the National Museum bears witness to such encounters, for one is broken midway between tip and base; and that it was broken during life is evident from the fact that the stump is healed and rounded over, while the size of the horns shows that their owner reached a ripe old age.

For, unlike man and the higher vertebrates, reptiles and fishes do not have a maximum standard of size which is soon reached and rarely exceeded, but continue to grow throughout life, so that the size of a turtle, a crocodile, or a Dinosaur tells something of the duration of its life.

Before quitting *Triceratops* let us glance for a moment at its skeleton. Now among other things a skeleton is the solution of a problem in mechanics, and in *Triceratops* the head so dominates the rest of the structure that one might almost imagine the skull was made first and the body adjusted to it. The great head seems made not only for offense and defense; the spreading frill serves for the attachment of muscles to sustain the weight of the skull, while the work of the muscles is made easier by the fact that the frill reaches so far back of the junction of head with neck as to largely counterbalance the weight of the face and jaws. When we restored the skull of this animal it was found that the center of gravity lay back of the eye. Several of the bones of the neck are united in one mass to furnish a firm attachment for the muscles that support and move the skull, but as the movements of the neck are already restricted by the overhanging frill, this loss of motion is no additional disadvantage.

To support all this weight of skull and body requires very massive legs, and as the fore legs are very short, this enables *Triceratops* to

browse comfortably from the ground by merely lowering the front of the head.

These forms we have been considering were the giants of the group, but a commoner species, *Thespesius*, though less in bulk than those just mentioned, was still of goodly proportions, for, as he stalked about, the top of his head was 12 feet from the ground.

*Thespesius* and his kin seem to have been comparatively abundant, for they have a wide distribution, and many specimens, some almost perfect, have been discovered in this country and abroad. No less than 29 *Iguanodons*, a European relative of *Thespesius*, were found in one spot in mining for coal at B r nissart, Belgium. Here, during long years of Cretaceous time, a river slowly cut its way through the coal-bearing strata to a depth of 750 feet, a depth almost twice as great as the deepest part of the gorge of Niagara, and then, this being accomplished, began the work of filling up the valley it had excavated. It was then a sluggish stream with marshy borders, a stream subject to frequent floods, when the water, turbid with mud and laden with sand, overflowed its banks, leaving them, as the waters subsided, covered thickly with mud. Here, amidst the luxuriant vegetation of a semi-tropical climate, lived and died the *Iguanodons*, and here the pick of the miner rescued them from their long entombment to form part of the treasures of the museum at Brussels.

Like other reptiles, living and extinct, *Thespesius* was continually renewing his teeth, so that as fast as one tooth was worn out it was replaced by another, a point wherein *Thespesius* had a decided advantage over ourselves. On the other hand, as there was a reserve supply of something like 400 teeth in the lower jaw alone, what an opportunity for the toothache!

And then we have a multitude of lesser Dinosaurs, including the active, predatory species with sharp claws and double-edged teeth. *Megalosaurus*, the first of the Dinosaurs to be really known, was one of these carnivorous species, and from our West comes a near relative, *Ceratosaurus*, the nose-horned lizard, a queer beast with tiny fore legs, powerful, sharp-clawed hind feet, and well-armed jaws. A most formidable foe he seems, the more that the hollow bones speak of active movements, and Professor Cope pictured him, or a near relative, vigorously engaged in combat with his fellows, or preying upon the huge but helpless herbivores of the marshes, leaping, biting, and tearing his enemy to pieces with tooth and claw.

Professor Osborn, on the other hand, is inclined to consider him as a reptilian hyena, feeding upon carrion, although one can but feel that such an armament is not entirely in the interests of peace.

Last, but by no means least, are the *Stegosaurus*s, or plated lizards; for not only were they beasts of goodly size, but they were among the most singular of all known animals, singular even for Dinosaurs.



MOLOCH POSING AS A DINOSAUR.  
From a drawing by J. M. Gleeson.







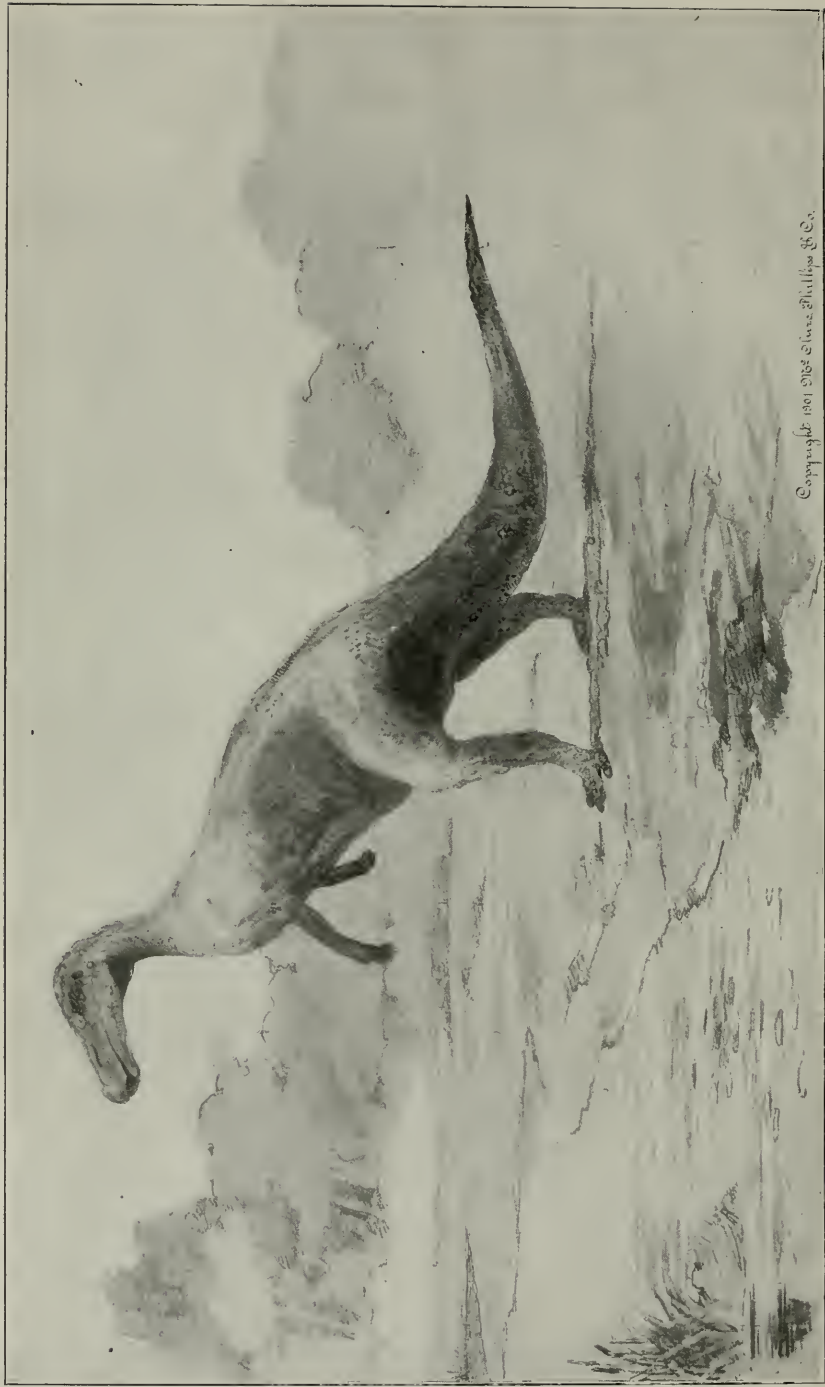

Copyright 1901, Messrs. Phillips & Co.

Copyright, McClure, Phillips & Co.

**THESPESIUS, A COMMON CRETACEOUS DINOSAUR.**

From a drawing by C. R. Knight.

but big enough, he could give even *Stegosaurus* "points" in more ways than one.

Standing before the skull of *Triceratops*, looking him squarely in the face, one notices in front of each eye a thick guard of projecting bone, and while this must have interfered with vision directly ahead it must have also furnished protection for the eye. So long as *Triceratops* faced an adversary he must have been practically invulnerable, but as he was the largest animal of his time, upward of 25 feet in length, it is probable that his combats were mainly with those of his own kind and the subject of dispute some fair female upon whom two rival suitors had cast covetous eyes. What a sight it would have been to have seen two of these big brutes in mortal combat as they charged upon each other with all the impetus to be derived from ten tons of infuriate flesh! We may picture to ourselves horn clashing upon horn, or glancing from each bony shield until some skillful stroke or unlucky slip placed one combatant at the mercy of the other, and he went down before the blows of his adversary "as falls on Mount Alvernus a thunder-smitten oak."

A pair of *Triceratops* horns in the National Museum bears witness to such encounters, for one is broken midway between tip and base; and that it was broken during life is evident from the fact that the stump is healed and rounded over, while the size of the horns shows that their owner reached a ripe old age.

For, unlike man and the higher vertebrates, reptiles and fishes do not have a maximum standard of size which is soon reached and rarely exceeded, but continue to grow throughout life, so that the size of a turtle, a crocodile, or a Dinosaur tells something of the duration of its life.

Before quitting *Triceratops* let us glance for a moment at its skeleton. Now among other things a skeleton is the solution of a problem in mechanics, and in *Triceratops* the head so dominates the rest of the structure that one might almost imagine the skull was made first and the body adjusted to it. The great head seems made not only for offense and defense: the spreading frill serves for the attachment of muscles to sustain the weight of the skull, while the work of the muscles is made easier by the fact that the frill reaches so far back of the junction of head with neck as to largely counterbalance the weight of the face and jaws. When we restored the skull of this animal it was found that the center of gravity lay back of the eye. Several of the bones of the neck are united in one mass to furnish a firm attachment for the muscles that support and move the skull, but as the movements of the neck are already restricted by the overhanging frill, this loss of motion is no additional disadvantage.

To support all this weight of skull and body requires very massive legs, and as the fore legs are very short, this enables *Triceratops* to

browse comfortably from the ground by merely lowering the front of the head.

These forms we have been considering were the giants of the group, but a commoner species, *Thespesius*, though less in bulk than those just mentioned, was still of goodly proportions, for, as he stalked about, the top of his head was 12 feet from the ground.

*Thespesius* and his kin seem to have been comparatively abundant, for they have a wide distribution, and many specimens, some almost perfect, have been discovered in this country and abroad. No less than 29 *Iguanodons*, a European relative of *Thespesius*, were found in one spot in mining for coal at B ruijsart, Belgium. Here, during long years of Cretaceous time, a river slowly cut its way through the coal-bearing strata to a depth of 750 feet, a depth almost twice as great as the deepest part of the gorge of Niagara, and then, this being accomplished, began the work of filling up the valley it had excavated. It was then a sluggish stream with marshy borders, a stream subject to frequent floods, when the water, turbid with mud and laden with sand, overflowed its banks, leaving them, as the waters subsided, covered thickly with mud. Here, amidst the luxuriant vegetation of a semi-tropical climate, lived and died the *Iguanodons*, and here the pick of the miner rescued them from their long entombment to form part of the treasures of the museum at Brussels.

Like other reptiles, living and extinct, *Thespesius* was continually renewing his teeth, so that as fast as one tooth was worn out it was replaced by another, a point wherein *Thespesius* had a decided advantage over ourselves. On the other hand, as there was a reserve supply of something like 400 teeth in the lower jaw alone, what an opportunity for the toothache!

And then we have a multitude of lesser Dinosaurs, including the active, predatory species with sharp claws and double-edged teeth. *Megalosaurus*, the first of the Dinosaurs to be really known, was one of these carnivorous species, and from our West comes a near relative, *Ceratosaurus*, the nose-horned lizard, a queer beast with tiny fore legs, powerful, sharp-clawed hind feet, and well-armed jaws. A most formidable foe he seems, the more that the hollow bones speak of active movements, and Professor Cope pictured him, or a near relative, vigorously engaged in combat with his fellows, or preying upon the huge but helpless herbivores of the marshes, leaping, biting, and tearing his enemy to pieces with tooth and claw.

Professor Osborn, on the other hand, is inclined to consider him as a reptilian hyena, feeding upon carrion, although one can but feel that such an armament is not entirely in the interests of peace.

Last, but by no means least, are the *Stegosaurus*s, or plated lizards; for not only were they beasts of goodly size, but they were among the most singular of all known animals, singular even for Dinosaurs.



MOLOCH POSING AS A DINOSAUR.  
From a drawing by J. M. Gleeson.





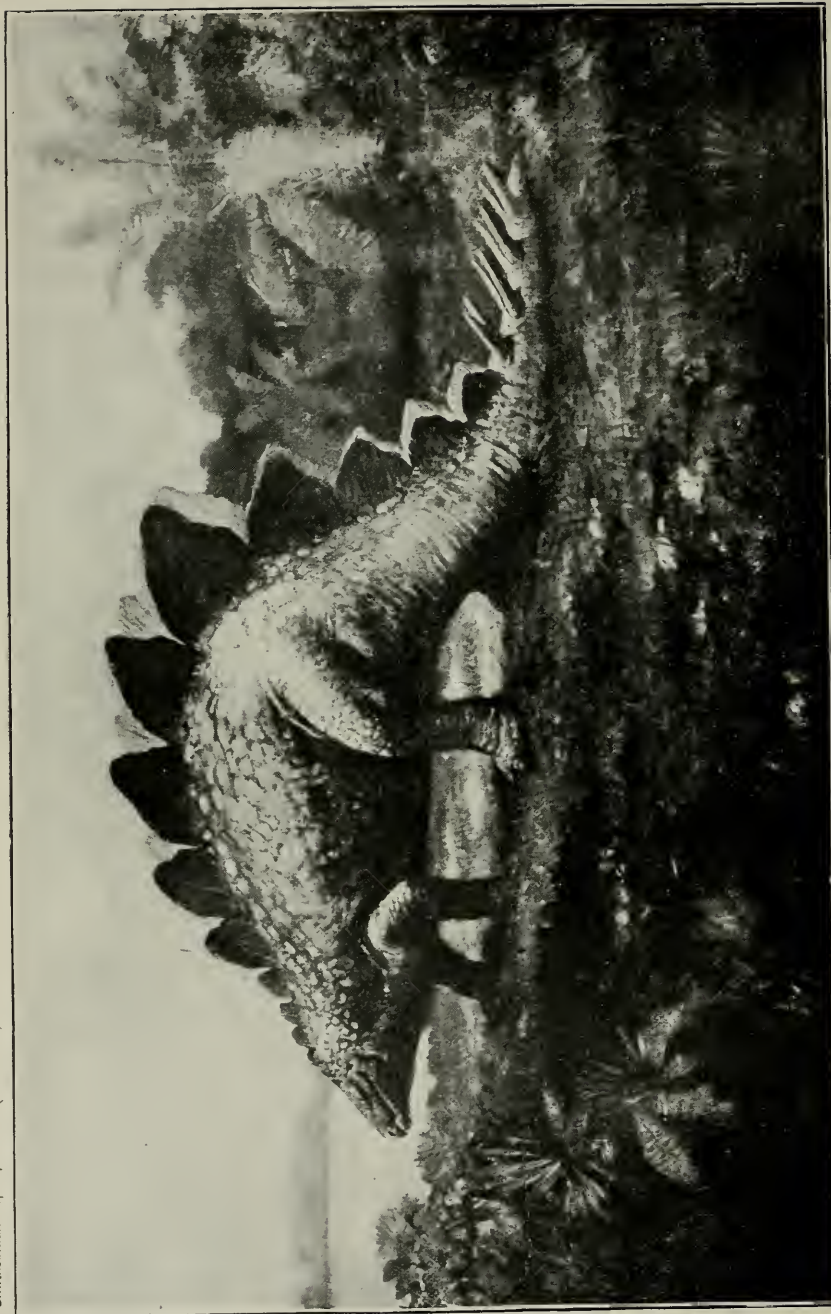



They had diminutive heads, small fore legs, long tails armed on either side near the tip with two pairs of large spines, while from these spines to the neck ran series of large but thin and sharp-edged plates standing on edge, so that their backs looked like the bottom of a boat provided with a number of little centerboards. Just how these plates were arranged is not decided beyond a peradventure, but while originally figured as having them in a single series down the back, it seems much more probable that they formed parallel rows.

The largest of these plates were 2 feet in height and length, and not more than an inch thick, except at the base, where they were enlarged and roughened to give a firm hold to the thick skin in which they were imbedded. Be it remembered, too, that these plates and spines were doubtless covered with horn, so that they were even longer in life than as we now see them. The tail spines varied in length, according to the species, from 8 or 9 inches to nearly 3 feet, and some of them have a diameter of 6 inches at the base. They were swung by a tail 8 to 10 feet long, and, as a visitor was heard to remark, one wouldn't like to be about such an animal in fly time.

Such were some of the strange and mighty animals that once roamed this continent from the valley of the Connecticut, where they literally left their footprints on the sands of time, to the Rocky Mountains, where the ancient lakes and rivers became cemeteries for the entombment of their bones.

The labor of the collector has gathered their fossil remains from many a Western canyon; the skill of the preparator has removed them from their stony sepulchres, and the study of the anatomist has restored them as they were in life.





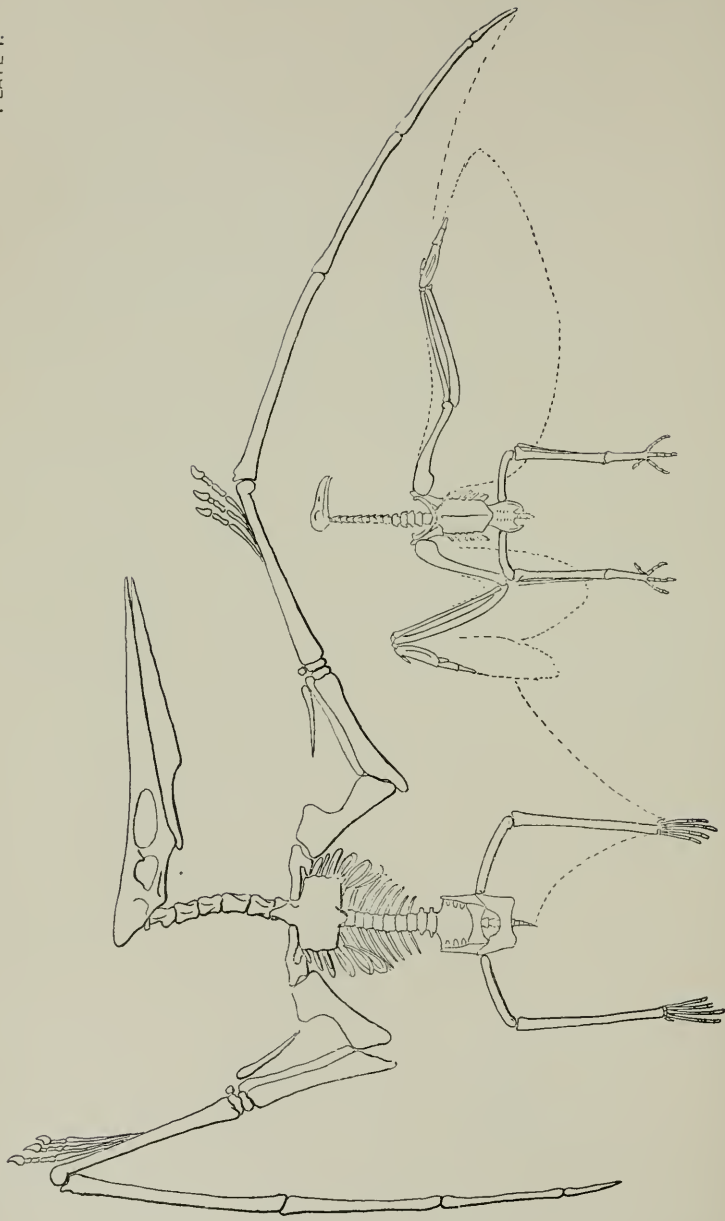

SKELETON OF THE GREAT PTERODACTYL ORNITHOSTOMA COMPARED WITH THAT OF THE CONDOR.  
The Pterodactyl after a figure by Prof. S. W. Williston.

## THE GREATEST FLYING CREATURE.

---

By S. P. LANGLEY.

(*Introducing a paper by F. A. Lucas.*)

---

A question of interest to all who are attracted to the subject of aerial navigation by flying machines (or things heavier than the air, and which, therefore, do not float like a balloon, but are dependent entirely on some mechanical power for their support) is, "What has nature herself done in the way of large flying machines, and are the birds which we see now the limit of her ability to construct them?"

In former epochs of our planet's history there were larger flying creatures than now, notably the Pterodactyl, "a brother to dragons," a reptile rather than a bird, but a reptile with enormously great wings. We do not know just how great this was in the living creature, except conjecturally, for we have only the skeleton. To take the expanse of the wing skeleton of a bird as giving us the expanse of wing of the actual bird would be to greatly underestimate it, the stretch of the skeleton being much less. The skeleton (which is all we have left of the Pterodactyl, a featherless reptile, and in that important respect different from a bird) will be more nearly in expanse that of the living creature.

We have here in the illustration (Pl. I) a larger than ordinary specimen of *Ornithostoma*, a Pterodactyl whose skeleton indicates a spread of wing of about twenty feet.

It is compared with that of the condor, nearly the largest bird now on the planet.

For my immediate purpose I will recall to the reader that birds are divisible into two classes: (1) those who soar with little motion of their wings, and yet in some mysterious manner keep their generally weighty bodies afloat on the yielding air, and (2) those who flap their wings.

*Ornithostoma* belongs almost unquestionably to the first of these classes. Its weight is not to be exactly estimated, but from a variety of considerations, part of which are quoted by Mr. Lucas in the ensuing paper, it is possible that the average specimen of *Ornithostoma*, in spite of its great wing space, did not weigh over thirty pounds.

Now we wish for our especial purpose of comparing this bird with other flying things, to know (*a*) the supporting area in square feet, (*b*) the weight, and (*c*) the power for (1) a flying machine of man's invention, which has actually flown for comparatively long distances, (2) like facts for this the largest of nature's flying machines, and (3) for some of our present birds. To recapitulate, we need for our special purpose at least the following data for any flying thing, namely, (1) the supporting area in square feet, (2) the weight in pounds, and (3) the horsepower which drives it through the air.

It is evidently impossible to exactly recover all of these for the Pterodactyl, and hard to definitely establish all three even in living specimens, but we may assume in the case of the horsepower that it is proportioned to the area of the attachment of the muscles which moved

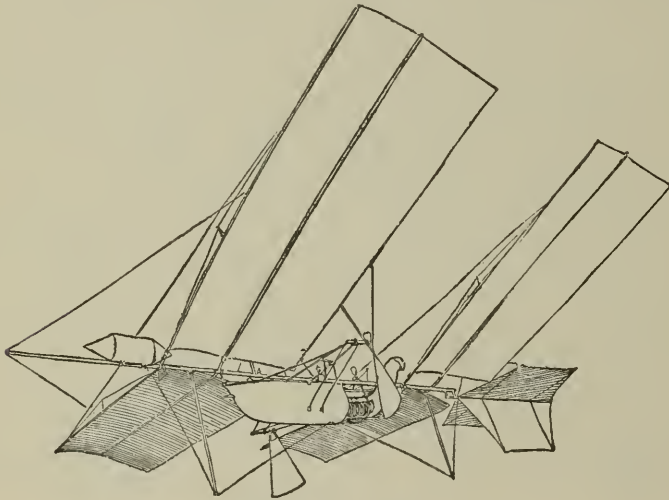

Diagram of the Aërodrome.

the bird in flight, an assumption which is doubtless only approximately true, but may serve our immediate purpose. With this understanding I present, together with an instantaneous photograph of a steel flying machine in actual flight (Pl. II) (repeated here from a previous publication), a diagram (Pis. III, IV) representing the above three facts in the case of (1) the flying machine, (2) the Pterodactyl (Ornithostoma), (3) the condor, and (4) the buzzard, all soaring things, and (5) the wild goose, (6) the pigeon, and (7) the humming bird, which last three fly by moving their wings.

This steel flying machine shown in the instantaneous photograph had a supporting area of 54 square feet, a weight of 30 pounds, developed  $1\frac{1}{2}$  horsepower, and repeatedly flew from one-half a mile to three-quarters of a mile. These facts are represented in the diagram by the three rectangular figures whose areas are proportional to these values. Immediately after it comes nature's greatest flying machine,



LANGLEY'S AERODROME NO. 5 IN FLIGHT, MAY 6, 1896.

From instantaneous photograph by A. Graham Bell, esq.





the Pterodactyl. This may have been quite 20 feet from tip to tip of wing. The paleontologist says that approximately the wing surface was 25 square feet, the weight something like 30 pounds, and I infer from the consideration just quoted that the power was probably less than 0.05 horsepower; the immensely greater economy and efficiency of nature in the respect of power being most strikingly shown by the size of the small rectangle as compared with that in the flying machine of man's invention.

After this comes the condor, preeminently a soarer. Its stretch of wing is 9 to 10 feet, its supporting area very nearly 10 square feet, its weight 17 pounds, and the approximate horsepower it develops (inferred from the facts already stated) scarcely 0.05.

Next comes the turkey buzzard, whose stretch of wing is 6 feet, its supporting area a little over 5 square feet, its weight 5 pounds, and the approximate horsepower it develops (as above) 0.015.

All the above are soaring birds. I now pass to another order of birds, which flap their wings. The wild goose, with a supporting area of 2.7 square feet, has a weight of 9 pounds, and needs a proportionately greater power of nearly 0.026 horsepower to drive it, as against scarcely 0.02 horsepower in the last example.

Next we have another familiar bird, the pigeon, which drives itself by flapping the wings. This has an area of about 0.7 of 1 square foot, a weight of 1 pound, and a horsepower of 0.012.

Below this we come to the humming bird, whose area, being shown on the same scale as the others, is almost too small to be distinguished on the page, but which has a supporting surface of nearly 0.03 of a square foot, a weight less than 0.02 of a pound, and a horsepower of probably not over 0.001. (All these values, as we have already said, are but approximative.)

Particular attention is to be paid to the fact that regarding the ratios of supporting surface to weight supported, these ratios are not only not the same in all the birds, but themselves differ greatly, but systematically, with the absolute weight. If we inquire how much 1 horsepower would support, for instance, supposing the ratios of sustaining surface (i. e., wing area) to weight to be constant, we find that 1 horsepower would, in the flying machine, support 20 pounds with 36 square feet area of wing (i. e.,  $1\frac{3}{4}$  square feet to a pound); and that, passing to the flapping birds, if the wild goose were to preserve the same relations on an enlarged scale, its 1 horsepower would support 346 pounds of weight with the use of 101 square feet of wing surface or 0.29 square feet to the pound; that in the pigeon 1 horsepower would support 83 pounds of weight with the use of 58 square feet of wing surface or 0.7 square feet to the pound, and that in the humming bird 1 horsepower would support 15 pounds of weight with the use of 26 square feet of wing surface or 1.73 square feet to the pound. So that, broadly speaking, so far as these few examples go, the

larger the creature the less relative surface and power is needed for its support.

From the obvious mathematical law that the area in bodies in general increases as the square of their dimensions, while their weight increases as the cube, it is an apparently plain inference that the larger the creature or machine the less the relative area of support may be (that is, if we consider the mathematical relationship, without reference to the question whether this diminished support is actually physically sufficient or not), so that we soon reach a condition where we can not imagine flight possible. Thus, if in a soaring bird which we may suppose to weigh 2 pounds we should find that it had 2 square feet of surface, or a ratio of a foot to a pound, it would follow from the law just stated that in a soaring bird of twice the dimension we should have a weight of 16 pounds and an area of 8 square feet, or only half a square foot of supporting area to the pound of weight, so that if flight is possible in the first case it would appear to be highly improbable in the second. The difficulty grows greater as we increase the size, for when we have a creature of three times the dimensions we shall have twenty-seven times the weight and only nine times the sustaining surface, which is but one-third of a foot to a pound. This is a consequence of a mathematical law, from which it would appear to follow that we can not have a flying creature much greater than a limit of area like the condor, unless endued with extraordinary strength of wing.

But this apparently necessary mathematical consequence is not the law of nature, for while it is found that in the larger bird a smaller area for each pound of the weight is given under the law than in the smaller bird, it is also found (what is another thing) that this smaller area is nevertheless sufficient, and that from the mathematical law just cited there does not follow the apparently obvious consequence (notably in the larger creatures like the condor, perhaps less notably in such a creature as the Pterodactyl) that the bird can not be supported, and while the fact is certain that it can, the cause of this does not seem to be clearly known.

Special cases, it may be said, may furnish an exception to what in the nature of things must be the general rule. Such, however, again does not seem to be the fact. This anomaly which is even now not generally appreciated seems to have been first noticed by a French observer, M. de Lucy, who about 1868 published a memoir, which I have not seen in the original, but an English translation of which was published in the Fourth Annual Report of the Aeronautical Society of Great Britain for 1869, and an extract from which is here reproduced. The same facts are given at greater length in an article by Dr. Karl Müllenhoff, of Berlin, in the *Archiv für die Gesammte Physiologie*, Volume XXXV from which Plate V is taken.



Supporting Area in Square Feet

Scale, 1 sq. in. = 25 sq. ft.

Weight in Pounds

Scale, 1 sq. in. = 15 pounds.

Horse Power

Scale, 1 sq. in. = 0.75 horse power.

FLYING MACHINE

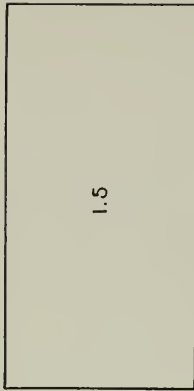
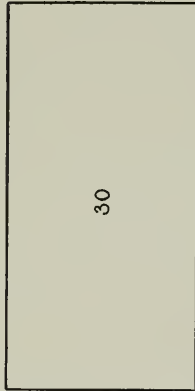
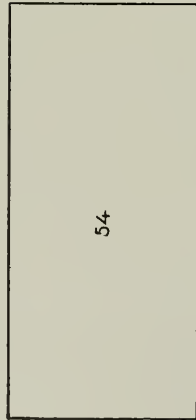

PTERODACTYL

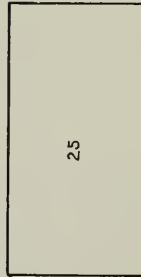

0.036

CONDOR

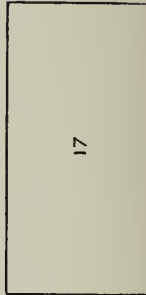
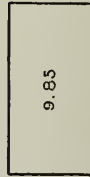

0.043

—TURKEY BUZZARD—  
5.3      5      0.015

---

SOARING  
FLAPPING

—WILD GOOSE—  
2.65      9      0.025

—PIGEON—  
0.7      1      0.012

—HUMMING BIRD—  
0.026      0.015      0.001



*M. de Lucy's table.*

[From the Fourth Annual Report of the Aeronautical Society of Great Britain for 1869, page 63.]

## INSECTS.

Names.	Square feet of wing surface per pound of weight.
Gnat.....	49
Dragon fly (small).....	30
Coccinella (ladybird).....	26.6
Dragon fly (common).....	21.6
Tipula, or daddy longlegs.....	14.5
Bee.....	5.25
Meat fly.....	5.6
Drone (blue).....	5.08
Cockchafer.....	5.15
Lucanus cervus, stag beetle (female).....	4.66
Lucanus cervus, stag beetle (male).....	3.75
Rhinoceros beetle.....	3.11

## BIRDS.

Swallow.....	4.82
Sparrow.....	2.72
Turtle dove.....	2.13
Pigeon.....	1.25

In this table each creature is supposed to be magnified or diminished in all its existing proportions till it weighs 1 pound. The surface dimensions of its wings will then be as given.

The above insects and birds vibrate their wings and do not soar. The table shows that the law (i. e., the law that the larger the creature the less the necessary relative area of support to a given weight) holds not only in the case of the large soaring bird, but in the case of smaller ones which flap their wings, and even in the case of insects. The explanation may be very near at hand, but it is not to me evident.

The accompanying table, from Mouillard's *L'Empire de L'Air*, deals with the same facts, and exhibits the paradoxical law that the greater the creature the smaller the (relative) supporting surface:

*Table showing weight, wing area, and square feet of wing surface which sustains 1 pound of weight.*<sup>a</sup>

Latin name.	Common name.	Weight in pounds.	Wing surface in square feet.	Square feet of wing surface per pound of weight.
Scops zorea.....	Screech owl.....	0.33	0.776	2.35
Accipiter nisus.....	Sparrow hawk.....	.336	.69	2.05
Larus melanocephalus.....	Black-headed gull.....	.619	.92	1.49
Astur palumbarius.....	Goshawk.....	.641	.81	1.31
Otus brachyotus.....	Short-eared owl.....	.67	1.50	2.24
Ibis falcinellus.....	Glossy ibis.....	.806	1.24	1.51
Corvus corax.....	Raven.....	1.34	2.50	1.87
Milvus egyptiacus.....	Kite.....	1.11	3.02	2.11
Pandion haliaetus.....	Fishhawk.....	2.80	3.01	1.08
Neophron perenopterus.....	Scavenger vulture.....	3.83	3.65	.95
Cathartes aura.....	Turkey buzzard.....	5.6	5.33	.95
Pelecanus onocrotalus.....	White pelican.....	6.66	6.32	.95
Phœnicopterus antiquorum.....	Flamingo.....	6.34	3.50	.55
Gyps fulvus.....	Griffon vulture.....	16.52	11.38	.68
Sarcophamphus gryphus.....	Condor.....	16.52	9.80	.59
Otogyps auricularis.....	Eared vulture.....	17.76	11.99	.68

<sup>a</sup>Data compiled chiefly from Mouillard, L. P., *L'Empire de L'Air*, Paris, 1881.

The curve (Plate V) shows the same facts in a graphic form, and they seem to me to deserve a fuller explanation than has yet been given to them.

I now invite the reader's attention to Mr. Lucas's interesting paper.

S. P. LANGLEY.

---

THE GREATEST FLYING CREATURE, THE GREAT PTERODACTYL  
ORNITHOSTOMA.

---

By F. A. LUCAS.

*United States National Museum.*

---

No one animal combines all the best features of weight, power, and wing area needed in a flying machine, for those with the greatest expanse of wing are by no means the heaviest and strongest, while the most powerful birds are not those of the longest sustained flight or those which fly to the best advantage if considered from an economical standpoint. The Frigate Bird, which is perhaps the bird of all others most at home in the air, lacks carrying capacity, being so far as mere muscle goes comparatively weak, sailing by skill and not by strength. Birds of prey, on the other hand, which can carry away a quarry of very nearly their own weight, fly when they do this by labored strokes of their powerful pinions, with an apparent expenditure of considerable power, sailing or soaring only when not encumbered by extra weight.

The Albatross, which has a maximum weight of 18 pounds and a spread of wing of 11 feet 6 inches, is the most notable example we have of long sustained flight in a heavy bird,<sup>a</sup> and it is the more remarkable from the fact that as the wing is extremely narrow its area is very small, not exceeding 7 square feet. The surplus lifting power of this bird is quite small, since the wing muscles on whose area we must base our estimate of the amount of force exercised in flight are comparatively small. Both the Albatross and Frigate Bird, however, are of double interest from the very fact of their great extent of wing and small amount of muscle, since they thus throw some light on the question of the length of wing that may be manipulated with a given force.

---

<sup>a</sup> Sailors sometimes catch an Albatross, fasten to it a tag bearing the name of the ship, date of capture, latitude and longitude, and then release the bird. A specimen thus tagged and subsequently taken by another ship is preserved in the museum of Brown University, showing that in twelve days it had traversed a distance of at least 3,150 miles, probably more, since the Albatross rarely flies in a direct line.



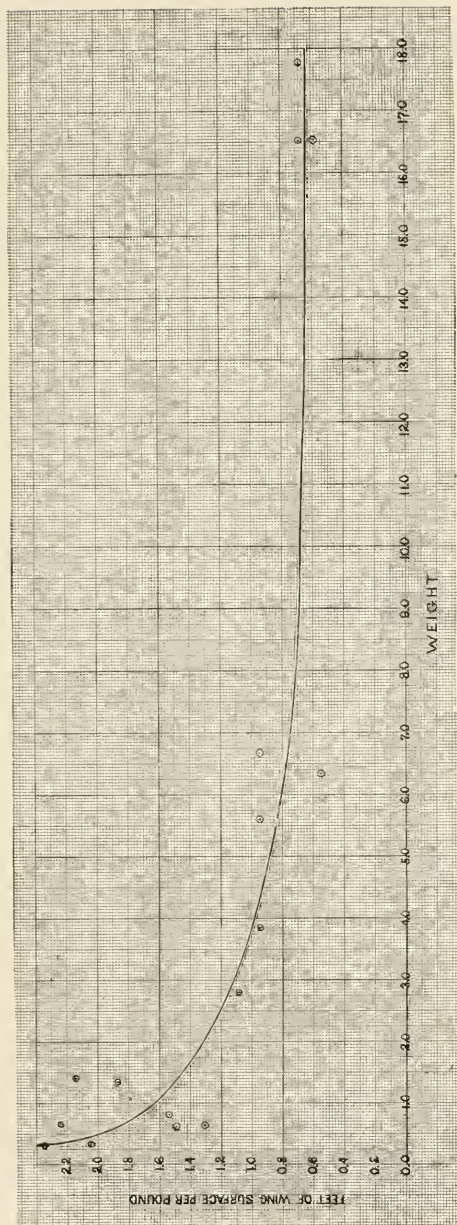

CURVE SHOWING RELATIVE DECREASE OF WING SURFACE WITH INCREASED WEIGHT OF BIRD.



The Condor, and his cousin, the California Vulture, weigh about the same as an Albatross,<sup>a</sup> but the broad, rounded shape of their wings gives them a much greater area, and this difference is, in turn, related to differences in flight, for the great vultures soar high in the air, while the Albatross skims the sea, rarely rising to an elevation of 150 feet.

It is to be noted, however, that the question of food has something to do with the mode of flight, since the one bird seeks its food from the surface of the water, while the other mounts aloft to scan the earth in search of something eatable.

Humboldt is credited with having seen a Condor soaring above the summit of Chimborazo; but that this or any bird ever attains such an altitude<sup>b</sup> is more than questionable, and Whymper, the most recent and most careful observer, puts the range of the great Vulture at from 7,000 to 15,000 feet.

The Condor is said to attain a spread of wing of 15 feet, but no bird of anything like this size is preserved in any collection, and even 10 feet 6 inches from tip to tip may be looked upon as exceeding the normal or average size.<sup>c</sup> As the Albatross averages 10 feet from tip to tip, and is said by good observers to reach 12 or even 14 feet,<sup>d</sup> it may be pretty safely set down as having the greatest stretch of wing of any animal now living. Certainly the Albatross stands first in length of wing bones, for these measure 8 feet 3 inches in the great wandering Albatross, while the bones of a large Condor have a combined length of but 6 feet  $\frac{1}{2}$  inch. Moreover, the Albatross inhabits the wind-swept seas of the Southern Hemisphere, one of the stormiest regions of the globe, and is continually called upon to wield its pinions in the teeth of gales, and the successful manner in which this is done calls forth the admiration of the observer.

So far as carrying weight is concerned, the Trumpeter Swan stands at or near the head of the list, for this bird attains a weight of 28 pounds, and carries this far and fast with a spread of wing of 8 feet. Its mode of flight is entirely different from that of the Albatross, being

<sup>a</sup> A California Vulture, 1 year old, in the National Zoological Park, weighed 18 $\frac{1}{2}$  pounds.

<sup>b</sup> Birds are known to migrate at a very considerable elevation, but it is believed that none have as yet been recorded so high as 4 miles. The height of Chimborazo is 20,494 feet.

<sup>c</sup> A fine Condor from Patagonia had a spread of only 8 feet 8 inches, and the California Condor in the National Zoological Park at Washington measures but 9 feet 2 $\frac{1}{2}$  inches across the wings. Like most large animals, Condors shrink woefully before a tape line.

<sup>d</sup> The largest of four Albatrosses measured by the writer had a spread of wings of only 10 feet 3 inches, but these were birds of 1 year and 2 years old, and many of the old birds seen were certainly much larger. The ship's carpenter claimed to have measured a bird of 12 feet spread.

performed by powerful wing beats, while the latter bird rarely flaps its wings, but sails over the water with little apparent expenditure of muscular power. In default of these birds the Wild Goose (*Bernida canadensis*) and Turkey Buzzard may serve as representatives of differences in method and apparatus of flight.

The goose, like his relative the swan, flies by means of the strokes of his wings and carries a weight of 9 pounds, with a wing area of 2.65 square feet and a muscle area of 8.84 square inches; the sailing buzzard, with a weight of 5 pounds, has a wing area of 5.3 square feet and a muscle area of 5.12 square inches. Thus the one bird has 0.3 square foot area of wing per pound of weight, while the other has 1.06 square feet per pound of weight. Or, if we wish to compare the area of wing to the area of sternum, we may say that in the goose this ratio is 43 to 1 and in the buzzard 149 to 1. The minimum of wing area, both positively and comparatively, is reached in the humming birds, which may be typified by a species common in Barbados (*Eulampis chlorolæmus*). This little bird, weighing 0.015 pound, has a wing area of 0.026 square foot, and a muscle area of 0.33 square inch, a ratio of 11.4 to 1, while, if brought up to ounces, the wing area per ounce would be but 0.76 square inch.

These differences are dwelt on at some length in the introduction to this paper, where they are graphically expressed by means of diagrams and compared with the weight, horsepower, and supporting area of a flying machine.

The buzzard may be compared to a racing yacht with small hull and great spread of canvas; the humming bird, like a torpedo boat, is mainly engine.

Mammals may be practically left out of consideration in discussing large flying creatures, for while many of the bats fly with the utmost dexterity, none of them attain any considerable size, the largest of the fruit bats (*Pteropus edulis*) weighing under 3 pounds and having a spread of wing of 5 feet. Almost everyone is acquainted with the rapid fluttering flight of small bats, and it need only be said that the large species fly with measured wing beats not unlike those of a crow.

Such are some of the flying forms of to-day, and, with few exceptions, they seem not to have been exceeded by any creatures of the past. *Harpagornis*, the extinct eagle of New Zealand, was larger and more powerful than any existing bird of prey, although the South American harpy eagle is a near second:<sup>a</sup> but the more notable exceptions were the great flying reptiles, or pterodactyls, which abounded on the shores of the inland sea that during Cretaceous time extended from the Gulf of Mexico up the Mississippi Valley and northwesterly through Kansas. And as the huge dinosaurs were the largest creatures that ever walked,

<sup>a</sup> A specimen of this bird, *Thrasaetus harpyia*, in the National Zoological Park, weighs 19½ pounds.



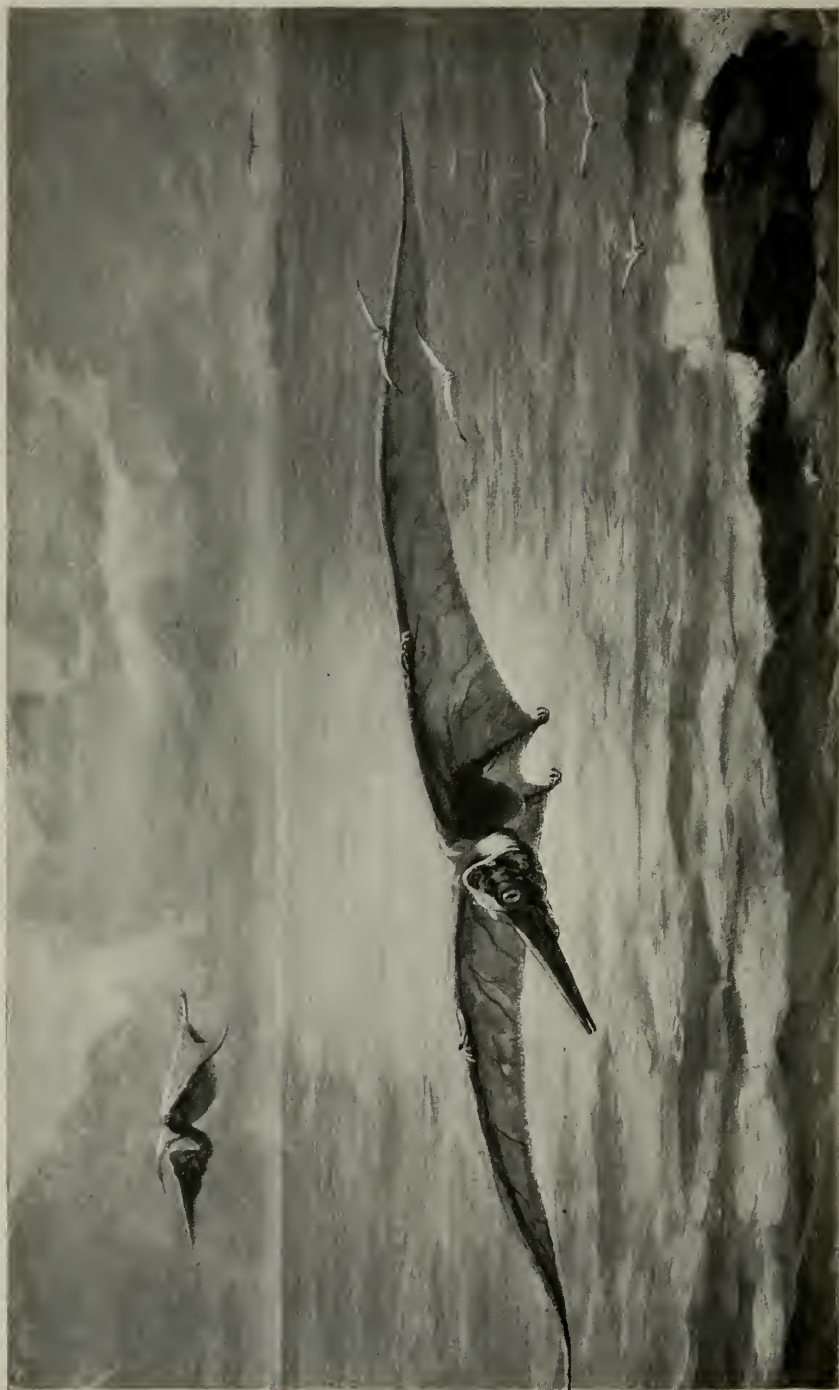

THE GREAT PTERODACTYL ORNITHOSTOMA.

so the greatest of these pterodactyls were the largest creatures that ever flew, their outstretched wings having a spread of 20 feet from tip to tip.

There is one possible rival, a bird supposed to be a relative of the pelicans, described by Professor Cope under the name of *Cyphornis*; but as this bird is known from a small fragment only and its wing area very far from certain, *Cyphornis* may be ruled out of competition.

The greatest of the pterodactyls, *Ornithostoma ingens* (Pl. VI), has been described at some length by Prof. S. W. Williston, of the State University of Kansas, and from his articles have been taken the facts relating to this curious creature that are herein embodied.

The great moa marks one extreme of specialization, the disproportionate size of the hind as compared with the fore limbs, for this big bird had legs 6 feet long and no fore legs at all; *Ornithostoma* marks the other extreme with a wing 9 feet in length and a leg so small and weak as to be of little use save for spreading the wing membrane. For, like other pterodactyls, whose wings are accurately known from their impressions in the fine-grained lithographic stone of Solenhofen, this species doubtless had a membranous wing something like that of a bat. As for the body, being that of a reptile, it must have been naked and possibly covered with small scales like those on the body of an iguana, so that on a small picture the skin would appear quite smooth. While the body was small in comparison with the extent of wing, the head, which was principally beak, was very nearly 4 feet long, extending backward to form a large but thin crest. This has a direct relation to the enormous length of the beak, since it furnished a point of attachment for muscles whose pull counterbalanced the leverage of the front part of the head. The beak was dagger-like, being very narrow, pointed, and quite toothless. Whether this beak was covered with a thin, hard skin, like the epidermis on the head of a crocodile, or with horn, like the bill of a bird, is not positively determined, but the weight of evidence is in favor of the former, since none of the pterodactyls yet found show any traces of a horny bill. In the peculiar shape of the lower, back portion of the beak there is a suggestion of the former presence of a small pouch, like that found in cormorants, and this would be in accord with the supposed fish-eating habits of *Ornithostoma*. Like other animals with long, narrow wings, *Ornithostoma* doubtless sailed somewhat after the manner of the albatross. This is inferred not only from the size and shape of the wing, but from the comparatively small size of the breastbone, to which were attached the muscles used in flight. Birds which fly by strokes of their pinions have the breastbone deeply keeled to furnish room for the attachment of the wing muscles, and the size of this keel is in direct relation to the rapidity of the wing strokes, reaching its maximum in the humming birds, in which the wings are vibrated so rapidly as to be invisible. Birds which sail have the breast muscles much

reduced, and the extreme of reduction is found in the frigate bird, which, with a spread of wing of 6 feet 4 inches, has a muscular area of only 3.50 square inches.<sup>a</sup>

There is another point in the anatomy of *Ornithostoma* besides length of pinion that lends strength to the supposition that it sailed, and this is found in the structure of the fore limb. It was pointed out by Mr. Huffaker that in spite of the deficiency of muscle shown by soaring birds the support of the wing was very strongly built; thus the frigate bird with its small breastbone has the bones of the shoulder joint firmly united with one another and with the breastbone. In the albatross strength is gained by shortening and widening the bone to which the wing is directly fastened and giving it a broad base for attachment to the breastbone. In the great pterodaetyls strength was obtained by bracing the shoulder blade against the backbone, in the

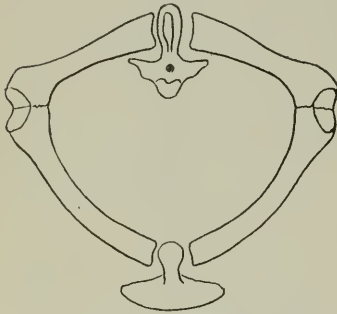

How the wing of *Ornithostoma* is supported.

manner shown in the diagram; thus the body, so to speak, was slung from the wings. In addition, three sections of the backbone were united in one piece in order to give a firm point of attachment, the whole arrangement curiously suggesting the fore leg of a turtle.

In spite of its great extent of wing, *Ornithostoma* was not a heavy animal, possibly not so heavy as the trumpeter swan, for the body was small and the bones reached the extreme of lightness, being far lighter than in any bird. This

may be appreciated by quoting Professor Williston's remark that the bones were almost papery in their character, one of the finger bones 26 inches long and 2 inches in diameter being no thicker than a cylinder of blotting paper. The same authority, basing his estimate on this extreme lightness of structure and the small size of the body, places the weight of one of these pterodaetyls at only 25 pounds, and with this weight and its great spread of wings the creature must have flown as lightly as a butterfly. Even if we increase the estimated weight by 20 per cent, we have a creature weighing but 30 pounds, so that the body was even more an appendage to the wings than in the frigate bird, and seems to have been just heavy enough to counterbalance the weight of head and neck and insure equilibrium.

<sup>a</sup>This is stated with some hesitancy, as no sternum of a large albatross is available, and it may be that, all things considered, the albatross has the least amount of wing muscle. The ratio of wing muscle to wing is smaller in the turkey buzzard than in the frigate bird, being, respectively, 1:125 and 1:114, this owing to the much broader wing of the buzzard. On the other hand, the great humming bird (*Patagona gigas*) has a ratio of muscle to wing area of 1:23, and a small species a ratio of but 1:11.39.





SKULL OF THE GREAT PTERODACTYL ORNITHOSTOMA.  
From a specimen in the Yale University Museum.



As *Ornithostoma* was capable of long sustained flight, and as its bones are found under conditions indicating that it went far out to sea, it is not improbable that it fed largely or entirely on fish. That they formed a part of its diet is certain, for fish bones and scales are found with the remains of pterodactyls, and it is easy to imagine this great reptile gliding over the sea, with outspread wings, snatching up fish right and left with its long beak as easily as a museum assistant picks them out of a jar of alcohol with a pair of forceps. The bird in the foreground is represented in our illustration as just turning to its right, the left wing being advanced and raised to cause the turn.

With its small body and enormous wings *Ornithostoma* may be looked upon as the king of flying creatures, and as more highly specialized than any flying animal before or since his time.

Finally, it is an interesting question as to whether or not the condor, the albatross, and the pterodactyl mark the limit of size attainable by flying creatures—are the mechanical difficulties in the way of using wings so great that evolution stops at a weight of 30 pounds and a spread of wing of 20 feet? Would animals above that size have trouble in manipulating their wings and be unable to compete with smaller and more active forms, or is it that the exigencies of life have never called for the development of a larger creature?

These are queries that may not be settled offhand, and it may only be said that the vast majority of birds are small and agile, and that, although birds and pterodactyls flew side by side over the Cretaceous seas and shores, the birds never reached the size of their reptilian associates, and, so far as we know, these mark the limit of size among flying animals.







H. H. JOHNSTON PINX

A. HOENES & CO., LITHOGRAPHERS, BALTIMORE

THE OKAPI.  
(OKAPIA JOHNSTONI)

REDUCED ONE HALF FROM SIR HARRY JOHNSTON'S ORIGINAL PAINTING  
REPRODUCED FROM PROCEEDINGS ZOOLOGICAL SOCIETY, LONDON, 1901. VOL. II

## THE OKAPI; THE NEWLY DISCOVERED BEAST LIVING IN CENTRAL AFRICA.<sup>a</sup>

---

By SIR HARRY H. JOHNSTON, K. C. B.,

*Special Commissioner for Uganda, British East Africa; the discoverer of the Okapi.*

---

The author of this article remembers having encountered in his childhood—say, in the later, sixties—a book about strange beasts in Central Africa which was said to be based on information derived from early Dutch and Portuguese works. The publication of this book was more or less incited at the time by Du Chaillu's discoveries of the gorilla and other strange creatures on the west coast of Africa, and its purport was to show that there were in all probability other wonderful things yet to be discovered in the Central African forests. Among these suggested wonders was a recurrence of the myth of the unicorn. Passages from the works of the aforesaid Dutch and Portuguese writers were quoted to show that a strange, horse-like animal of striking markings in black and white existed in the very depths of these equatorial forests. The accounts agreed in saying that the body of the animal was horse-like, but details as to its horn or horns were very vague. The compiler of this book, however, believed that these stories pointed to the existence of a horned horse in Central Africa.

Somehow these stories—which may have had a slight substratum of truth—lingered in the writer's memory, and were revived at the time Stanley published his account of the Emin Pasha expedition, In Darkest Africa. A note in the appendix of this book states that the Kongo dwarfs knew an animal of ass-like appearance which existed in their forests, and which they caught in pitfalls. The occurrence of anything like a horse or ass—animals so partial to treeless, grassy plains—in the depths of the mightiest forest of the world seemed to me so strange that I determined to make further inquiries on the subject whenever fate should lead me in the direction of the great Kongo forest. Fate was very kind to me in the matter. In the first place, soon after I arrived in Uganda, I was obliged to intervene to prevent a too-enterprising German carrying off by force a troop of Kongo

---

<sup>a</sup> Reprinted, by permission, from McClure's Magazine, September, 1901, pages 497-501.

dwarfs to perform at the Paris Exhibition. These little men had been kidnaped on Kongo Free State territory. The Belgian authorities very properly objected, and as the German impressario had fled with his dwarfs to British territory, they asked me to rescue the little men from his clutches and send them back to their homes. This I did, and in so doing, and in leading them back to the forests where they dwelt. I obtained much information from them on the subject of the horse-like animal which they called the "okapi."<sup>a</sup> They described this creature as being like a zebra, but having the upper part of its body a dark brown. The feet, however, they said, had more than one hoof.

When I reached Belgian territory, on the west side of the Semliki River, I renewed my inquiries. The Belgian officers at once said they knew the okapi perfectly well, having frequently seen its dead body brought in by natives for eating. They informed me that the natives were very fond of wearing the more gaudy portions of its skin; and calling forward several of their native militia, they made the men show me all the bandoliers, waist belts, and other parts of their equipment made out of the striped skin of the okapi. They described the animal as a creature of the horse tribe, but with large, ass-like ears, a slender muzzle, and more than one hoof. For a time I thought I was on the track of the three-toed horse, the hipparion. Provided with guides, I entered the awful depths of the Kongo forest with my expedition, accompanied also by Mr. Doggett, the naturalist attached to my staff. For several days we searched for the okapi, but in vain. We were shown its supposed tracks by the natives, but as these were footprints of a cloven-hoofed animal, while we expected to see the spoor of a horse, we believed the natives to be deceiving us, and to be merely leading us after some forest eland. The atmosphere of the forest was almost unbreathable with its Turkish-bath heat, its reeking moisture, and its powerful smell of decaying, rotting vegetation. We seemed, in fact, to be transported back to Miocene times, to an age and a climate scarcely suitable for the modern type of real humanity. Severe attacks of fever prostrated not only the Europeans, but all the black men of the party, and we were obliged to give up the search and return to the grass lands with such fragments of the skin as I had been able to purchase from the natives. Seeing my disappointment, the Belgian officers very kindly promised to use their best efforts to procure me a perfect skin of the okapi.

Some months afterwards the promise was kept by Mr. Karl Eriksson, a Swedish officer in the service of the Kongo Free State, who obtained from a native soldier the body of a recently killed okapi. He had the skin removed with much care, and sent it to me accom-

---

<sup>a</sup> As a matter of fact, the dwarfs pronounced the word "o'api," but the big black tribes of the forest called the creature "okapi."





HEAD OF THE OKAPI.

Drawn by Sir Harry H. Johnston.



H. J.

THE OKAPI.

Drawn by Sir Harry H. Johnston. From Mr. Rowland Ward's "Building up of the Animal in the British Museum."



panied by the skull of the dead animal, and a smaller skull which he had obtained separately. The skin and skulls were forwarded to London, where they arrived after considerable delay. The British Museum intrusted the setting up of the okapi to Mr. Rowland Ward, of Piccadilly, and from the mounted skin and other data I have made the drawings which illustrate this article. I also give a photograph, taken by myself, of a bit of forest where the okapi was found. Before sending this skin to Europe, and while it still retained some indications of the shape of the animal, I made the colored drawing which appears as the frontispiece to this issue of McClure's Magazine, and which will also be given in the Proceedings of the London Zoological Society. This colored drawing differs in some particulars from the appearance of the okapi as set up by Mr. Rowland Ward, and as represented in the illustrations of the present article. Until the okapi has been photographed alive or dead, and its exact shape in the flesh is thus known, it is difficult to say which of my two drawings is the more correct. In the first illustration, which appears as the frontispiece, I have given the creature a more horse-like build. In the sketch which accompanies this article, and which is in the main drawn from Mr. Rowland Ward's building up of the animal from the flat skin, the shape of the body inclines a little more to the giraffe, the okapi's nearest ally.

The size of the okapi is that of a large stag. It stands relatively higher in the legs than any member of the ox tribe, otherwise I should compare its size to that of an ox. Like the giraffe, this creature has only two hoofs, and no remains whatever of the other digits, which are represented in the deer, oxen, and in most antelopes by the two little "false hoofs" on either side of the third and fourth toes.

The coloration of the okapi is quite extraordinary. The cheeks and jaws are yellowish white, contrasting abruptly with the dark-colored neck. The forehead is a deep red chestnut; the large, broad ears are of the same tint, fringed, however, with jet black. The forehead ranges between vinous red and black in tint, and a black line follows the bridge of the nose down to the nostrils. The muzzle is sepia colored, but there is a faint rim or mustache of reddish-yellow hair round the upper lip. The neck, shoulders, barrel, and back range in tone from sepia and jet black to rich vinous red. The belly is blackish, except just under the knees. The tail is bright chestnut red, with a small black tuft. The hind quarters, hind and fore legs are either snowy white or pale cream color, touched here and there with orange. They are boldly marked, however, with purple-black stripes and splodges, which give that zebra-like appearance to the limbs of the okapi that caused the first imperfect account of it to indicate the discovery of a new striped horse. The soft parts of the animal being

as yet unknown, it can not be stated positively that the okapi possesses a prehensile tongue like the giraffe, but the long and flexible lips would seem to atone for the very weak front teeth. It is probably by the lips and tongue that the creature gathers the leaves on which it feeds, for according to the accounts of the natives it lives entirely on foliage and small twigs. Like all living ruminants (except the camel), it has no front teeth in the upper jaw. The molars are very like those of the giraffe.

My first examination of the skull and skin of the okapi caused me to name it tentatively "Helladotherium." The helladotherium was a giraffe-like animal that existed in the Tertiary epoch in Greece, Asia Minor, and India. In India the helladotherium attained a very great size, but the Greek specimens were not quite as large as the modern giraffe. The helladotherium was hornless, like the okapi, and in another point it resembled this animal, because the neck was not disproportionately long, and the fore and hind limbs were nearly equal in length. The okapi bears on its skull remains of three horn cores, once no doubt as prominent as those in the existing giraffes. The process of degeneration, however, has set in, and in the living okapi the horn cores have been worn down to two small knobs on the forehead, covered outwardly with little twists of hair, and one less conspicuous knob or bump just between the eyes. Though the okapi bears certain superficial resemblances to the helladotherium, it is probable, on the whole, that it comes nearest in relationship to the giraffe. Being, however, sufficiently different from both, it has been constituted by Prof. Ray Lankester a separate genus, to which he has given the name *Ocapia*.

So far as is yet known, the existing range of the okapi is confined to the northern part of the Kongo forest, near the Semliki River. The okapi is found in the little territory of Mboga, which is an outlying portion of the Uganda Protectorate. It is also found in the adjoining territory of the Kongo Free State. This same forest, I believe, conceals other wonders besides the okapi, not yet brought to light, including enormous gorillas. I have seen photographs of these huge apes, taken from dead animals which have been killed by the natives and brought in to the Belgians. A careful search might reveal several other strange additions to the world's mammalian fauna.

Quite recently fossil remains of giraffe-like animals have been found in Lower Egypt, as well as in Arabia, India, Greece, Asia Minor, and southern Europe. It is possible that the okapi and the giraffe are the last two surviving forms of this group in tropical Africa. The giraffe has escaped extermination at the hands of carnivorous animals by its development of enormous size and by its wary habits. The giraffe, unlike



THE HOME OF THE OKAPI, SEMLIKI FOREST, EASTERN KONGO FREE STATE.

From a photograph taken by Sir Harry H. Johnston.



the okapi, prefers relatively open country, dotted with the low acacia trees on which it feeds. Towering up above these trees, the giraffe with its large eyes can from 20 feet above the ground scan the surrounding country and detect the approach of a troop of lions, the only creature besides man which can do it any harm. Man, of course—the British and Boer sportsmen well in advance of the others—is doing his level best to exterminate the giraffe, as he has exterminated the mammoth, the Ur ox, the quagga, the dodo, and the auk. But for the presence of man, the giraffe might have been one of the lords of the earth. The defenseless okapi, however, only survived by slinking into the densest parts of the Kongo forest, where the lion never penetrates, and where the leopard takes to a tree life and lives on monkeys. The only human enemies of the okapi hitherto have been the Kongo dwarfs and a few black negroes of the larger types who dwell on the fringe of the Kongo forest. How much longer the okapi will survive now that the natives possess guns and collectors are on the search for this extraordinary animal, it is impossible to say. It is to be hoped very earnestly that both the British and Belgian Governments will combine to save the okapi from extinction.

The group of ruminants to which the *Ocapia* belongs includes at the present day the giraffe and possibly the prongbuck of North America. Far back in the history of the Artiodactyla,<sup>a</sup> when in a section of them horns became the dominant characteristic, these appendages were developed mainly in two different fashions. The deer tribe grew bony appendages which started from knobs on the frontal bones, and these appendages fell off and were renewed every twelve months. When the horns of the stag fall, they leave only a bony knob, which rises very little above the level of the skull. The *Boridae*, or oxen-antelope group, developed first long bony prominences which went on growing year by year up to the age of full maturity. These bony prominences came in time to be eased by horny coverings, and thus we have the hollow-horned ruminants; for when these horny coverings are removed from the long bony socket they are found to be hollow; they are not solid bony antlers growing from the top of a horn core. But midway between these two main groups there is a third, of which the giraffe and the prongbuck are two divergent specimens. Here was an intermediate stage between the deer and the oxen. Bony prominences, like those of the *Boridae*, but not so long, grew out from the skull and were covered with hair. From the top of these prominences (as in the case of the prongbuck, the extinct *Sivatherium*, and probably

<sup>a</sup>Most of the readers of McClure's Magazine are aware that the Artiodactyla are a suborder of ungulates in which the middle toes are equally developed. This group includes the hippopotamus, the pigs, camels, deer, giraffes, oxen, sheep, goats, and antelopes.

in the ancestors of the giraffe) grew antlers or horns which were shed from time to time, as in the deer. This is the case with the modern prongbuck, and in all probability this was the case with the ancestors of the giraffe and other early members of the giraffine family. To-day the giraffe only retains the long horn cores or sockets, from the end of which in all probability antlers once sprang. In the case of the okapi, as already remarked, these bony prominences have gradually dwindled to scarcely discernible bumps. In other respects, however, the new beast of Central Africa represents pretty nearly the primitive type from which the giraffe rose in exaggerated development of neck and limbs.



## OBSERVATIONS ON TERMITES, OR WHITE ANTS.

By G. D. HAVILAND, M. A., M. B., F. L. S.<sup>a</sup>

The Termitidæ, commonly known as "white ants," are insects feeding on wood and dead vegetable matter, living socially in colonies of sterile and fertile individuals, which grow very slowly and have no pupa stage. Antennæ situated in a shallow fossa at the side of the head just above the base of the mandibles. Mandibles powerful, except in the soldiers of some species. Maxillæ with double chitinous hooks and long 5-segmented palpi. Head hinged to the prothorax by means of a pair of lateral cervical sclerites. Tarsi of 4 segments, the distal as long as the three proximal together. Pronotum, mesonotum, and metanotum distinct. Abdomen of 10 segments; the ventral plate of the basal segment absent; that of the apical segment divided, and bearing at the lateral ends a pair of short cerci; that of the 9th segment in the larva, and often in the adult, with a pair of small papillæ near the center of its posterior border.

Males with a pair of compound eyes placed just above the antennal fossæ, and for the most part a pair of ocelli situated near their inner borders. Frequently there is a median fenestra. When young there are two pairs of large, membranous, nearly equal wings, which in rest are superposed and project far beyond the apex of the abdomen. These wings are used in flying from the nest, and then shed across a transverse basal line, leaving subtriangular wing stumps. The vas deferens opens behind the ventral plate of the 9th abdominal segment. The males live permanently along with the females, but there are no copulatory organs.

Females when young closely resemble the males. The ventral plates of the 8th and 9th abdominal segments are divided, and the halves are small and separated. When the female becomes the mother of a colony her abdomen enlarges by dilatation of the cuticle between the chitinous plates, and sometimes there is secondary chitinization extending forward from the anterior borders of the plates.

The soldiers are sterile, wingless, and for the most part blind. Their head is chitinous and strong, peculiarly and variously modified

<sup>a</sup> From Journal Linnean Society, Zoology, Vol. XXVI, 1897-98.

for defense. The segments of the antennæ are more elongate than in the males and females, and fewer, generally in the proportion of 8 to 9. The mandibles are very various in the different species, but very characteristic of each species, and quite different from those in the males and workers. The gula is large and firmly united to the head, generally for the greater portion of its length. The cervical sclerites are larger than in the males and workers. The thorax and abdomen are generally but little chitinized. The latter is generally more quadrate than in the workers. Some individuals have rudiments of ovaries, and some of testes; but the ventral plates of the 8th and 9th abdominal segments are always entire.

The workers are wingless and for the most part blind; they are but little chitinized, and larval in appearance. The head is round, the antennæ are shorter than in either male or soldier, and the number of segments intermediate. The mandibles are short and powerful and covered by the obtuse labrum. In species which nest in the wood on which they live the form is cylindrical, and the legs shorter than the abdomen. In species which wander much in search of food the thorax is considerably narrowed, and the legs longer than the abdomen.

Termites inhabit all the warm regions of the earth in countless numbers. They are unable to withstand a prolonged winter's frost. Their greatest enemies are ants. Their chief means of defense is their power of burrowing and building.

#### CLASSIFICATION.

In the matter of genera I have followed Hagen. His genera admit of distinctions common to every caste. The genus *Termites* contains numerous species of very diverse forms and habits, yet it can not be subdivided by characters common to every caste. \* \* \*

The genus *Termites* is so large that Hagen, who tried to make several genera of it, failed owing to the incompleteness of his material. I also have failed, and think that in the interests of naturalists the attempt should be postponed. The genus does, however, present natural groups and these I have attempted to define, but more material and further examination will alter the definitions and limits I have given. The groups can seldom be distinguished by characters common to every caste, nor are the limits of the groups the same if we rely on the soldiers as if we rely on the males.

The largest forms of the genus are fungus growers. There is an American group of large termites, represented by *T. dirus*, which are almost certainly fungus growers; the soldiers have a pair of lateral horizontal spines on the pronotum. There are three Old World groups of fungus growers. The most important is represented by *T. bellicosus*; it builds tall mounds; the imago and soldiers are of large size.

and the latter have a transparent tip to the labrum and a toothless margin to the mandibles. The second is represented by *T. vulgaris*; it builds insignificantly small mounds or none at all; the imago is large, but the soldiers are of moderate size, have a few bristles at the tip of the labrum and a minute tooth at the middle of the cutting margin of each mandible, or at any rate of the left one. The last group, represented by *T. incertus*, has individuals of moderate size and quite different habit from those of the previous groups.

A remarkable group, in which the soldiers have a very large foramen in front of the head, from which when angry they can discharge a copious viscid milky fluid, has been given the subgeneric name *Coptotermes* by Herr Wasmann. The group is quite worthy of generic rank.

Another remarkable group, in which the soldiers have a minute foramen in front of the head and a long labrum reaching to the tips of the strongly toothed mandibles, was given the subgeneric name *Rhinotermes* by Dr. Hagen. This group also is worthy of generic rank. \* \* \*

These groups, the fungus-growers, *Coptotermes* and *Rhinotermes*, have soldiers with pronotum more or less flat, and antennæ of usually more than 14 segments, and abdominal papillæ usually easily visible. They have imagos in which the wings show the median nerve midway between the submedian and subcostal. The remaining groups, containing much the larger number of the species, have imagos, in which the wings show the median nerve much nearer the submedian than the subcostal, and soldiers whose antennæ have seldom more than 14 segments. It is to these that Dr. Hagen gave the subgeneric name *Eutermes*; they comprise numerous groups, with difficulty recognized by the imagos, but readily recognized by the soldiers. The *Eutermes* had been previously applied by Heer to some fossil forms of the genus *Termes*, known only from the imago, and in one case only from the wings. The name was limited by Dr. Fritz Müller to a much smaller group, that in which the soldiers have rudimentary mandibles and a long, conical rostrum. He raised this group to generic rank. It is a natural group, worthy of generic rank, if indeed it be not worthy of forming several genera, but it was not in this sense that Heer or Hagen used the name *Eutermes*. \* \* \*

The species of the genus *Termes* seem in some cases to be very distinct and readily distinguishable, and in other cases to pass indistinguishably into one another. In the groups in which the species are not easily distinguishable, I have not attempted to outdo nature in distinctness; indeed, in this respect I am conscious of shortcomings. In every case I trust that more reliance will be placed on my specimens than on my descriptions.

## CHARACTERS.

The enormous number of individuals in a nest, all of whom may be considered as the children of the same parents, provides material for the study of normal variation and of specific limits scarcely to be met with elsewhere. The great difference of character in the different castes also introduces new conditions in the classification of species, and in the study of heredity, not often to be met with.

In the genus *Termes* the soldier is by far the best caste to determine species from; not only is the soldier easier to determine than the male, but it is found in almost every nest, and usually wherever the workers go. Though the imago was the caste on which Hagen founded most of his species, though it is the form found fossil in amber, though it is the form caught flying round a lamp at night, yet it is generally absent from the nests, and is often insufficient for the determination of species. I have not found the characters of the wings very useful or reliable. In one case I have based species on differences in the imago, though I could see no difference whatever in the soldier; but as a rule my species are based chiefly on apparent differences in the soldiers.

There are two external characters, which are correlated in the soldiers and the males of the genus *Termes*. The abdominal papillæ show a corresponding degree of development, and the number of segments of the antennæ is approximately in the proportion of 8 to 9. The characters of the antennæ are probably more important than any others in the determination of the species. It is easy enough with a little care to determine whether the apical segments are present or, as often happens, are broken off, for the apical segment is of a different shape from the others. Although the segments of the antennæ are fewer in soldier than in the male, they are generally longer and more cylindrical, so that the antennæ of the soldiers are often as long as or longer than those of the imago. The antennæ of the workers, on the other hand, are always much shorter, yet the number of segments which compose them is never less than in the soldier and never more than in the male. The actual length of the antennæ in the genus *Termes* seems to be but little correlated with the actual number of segments which compose them, whether we compare the different species, or whether we compare the different castes. Long antennæ go with long legs, and this is true whether we compare caste or species. Long legs and long antennæ go with much walking and foraging; and this is true when we look to differences between species, but not when we look to differences between castes. Soldiers with long, slender legs belong to species which forage for food at a distance from the nest; soldiers with short, stout legs belong to species sluggish in their movements, and which venture but little from home.

Blindness amongst the soldiers and workers is more universal than it is in ants. There seems no reason to doubt that the blindness is connected with the mode of life. The impossibility of attributing the blindness to the inherited effects of disuse, seeing that none of the parents in any of the species are blind, utterly discredits such an explanation in the case of other blind animals.

In all the castes the abdomen varies greatly in size and appearance, according to the nature of the contents.

The winged imagos have an unconquerable desire to leave the nest and to run the risk of dangers from which not one in many thousands escapes. By this means it is that interbreeding and distribution are effected. Dr. Fritz Müller aptly compared the winged individuals to perfect flowers, and the neotenic individuals to cleistogamic flowers. The comparison may be carried a step further. In temperate climates the winged forms appear in early summer. In equatorial regions they appear for the most part in simultaneous swarms at favorable seasons, while in some species they seem to be constantly produced in small numbers the whole year round. The problems of when to swarm and how many imagos to produce seem to be solved in nearly the same ways as the problems of when to flower and how many flowers to produce.

They fly but feebly, allowing themselves to be carried by the wind, and could scarcely cross more than a mile or two of water.

The wings are soon shed across a transverse basal line. The method of breaking off the wings is to elevate them. This will be found effective in dead insects. The live insect uses its legs and abdomen to elevate its wings, or in other cases pushes them against some object; yet in some cases the live insect will shed all four wings with inexplicable rapidity. Their wings not only prevent their burying themselves and hiding, but on a perfectly level surface are a danger to them, for birds are seen to pick up those with wings in preference to those without.

At the time of swarming the males and females of the genus *Termes* pair, the male following the female and often clinging to her abdomen, but there are no copulatory organs, and the sexual organs are not at that stage mature. In *Termopsis* and *Calotermes* it seems that the males and females do not run about in pairs.

In most if not in all species a pair of termites can found a nest without assistance. Smeathman, however, states that in *T. bellicosus* such pairs are protected by any soldiers and workers who may find them, and are by them treated as kings and queens. \* \* \*

The females do not differ from the males in head and thorax, though careful measurements may find the male to be the smaller. The abdomen of the females becomes at the last molt different from that of the males on account of a characteristic change in the ventral

plates of the 7th, 8th, and 9th abdominal segments. In all species of the genus *Termites* the abdomen subsequently swells to many times its original size; but this swelling is not accompanied by any molting; the chitinous plates do not alter, but become separated by the distension of the intervening cuticle. \* \* \* In most groups there are present a number of minute lateral thickenings, usually colored, and bearing each a hair.

When, as in most species, the queen is inclosed in a royal cell from which she is too large to escape, a familiarity with the nest and habits of the species will lead to her discovery without much trouble; but in all species other than the fungus-growers the king can leave the royal cell, and generally does so when he finds the nest is being opened. In many species, however, the queen wanders about the nest, and she then seeks, like the king, to avoid observation when the nest is being opened. In such cases there is only one way of searching methodically for her. Remove the nest with as little disturbance as possible to a convenient place free from the attacks of ants; a large table with its feet standing in water is the best place. Break the nest into fragments, remove each fragment one by one, examine it carefully, and put it aside in a safe place, so that the search may, if necessary, be gone through a second time. If the nest has been broken into fragments before it has been much disturbed, the king will be found in the same fragment as the queen. If the nest is broken into fragments gradually, the king, if found at all, will generally be found in the fragment last examined. The longest time I spent searching through one nest was three days. I found a king; the queen escaped me, but I feel confident that was due to my want of care, and she was really there.

I have found colonies which I believed to be, through some accident, queenless, and there are, no doubt, species in which a single colony owns several nests; but the rule is that every nest has a true royal pair. I have found as many as six true royal pairs; they were, as is always the case, in the same royal cell; their tarsi were injured, presumably as the result of quarreling.

When there is a true queen, she is, so far as my observations go, always accompanied by a true king. When there is more than one true queen, the number of true kings is generally equal to them; but often it is less, and occasionally it is greater. The king has no copulatory organs. From Professor Grassi's observations, it is probable that in *Calotermites* copulation nevertheless does take place. In *Termites malayanus* I have reason to think that the king fertilizes the eggs after they are laid; indeed, copulation in the case of kings and fully grown queens of most species of the genus *Termites* is apparently impossible.

I raised neotenic forms artificially in two species of *Calotermites*. In species of the fungus-growers neotenic forms have never been found. In five cases I removed the royal pairs from the nests of *T. malayanus*,

and after three or four months again examined the nests. In three out of the five cases substitution pairs exactly resembling the original ones, with well-formed wing stumps, were present; in the other two cases I could not find a royal cell, and believe that the loss had not been repaired.

Natural neoteinic forms are very abundantly found in some species, especially in those whose soldiers have a saddle-shaped pronotum and are mandibulated. In forms with nasute soldiers I found neoteinic queens in only two species, *T. borneensis* and *T. matangensis*. Neoteinic queens are generally raised in considerable numbers, and become fewer in number as they grow older. They are always found in the same part of the nest, although, unless few in number, they can not all occupy the same cell.

By neoteinic individuals I mean fertile individuals the condition of whose thorax makes it clear that they have never been capable of flight. Though the true queens are always accompanied by kings, the neoteinic queens are often consortless. They may be accompanied by one or more true kings, or by one or more neoteinic kings; but the kings are almost invariably less numerous than the queens, and are in many cases wholly absent. This last conclusion indeed rests on negative evidence only, and in the case in which I am most positive (*T. matangensis*, Nos. 358 and 359) neither eggs nor young larvæ were present in the nests, though wingless males and females were abundant.

The function of the soldiers I believe to be defense, and defense only. Some able observers have arrived at a different conclusion, but on what grounds I am not clear. There is a vast difference in functions of offense and functions of defense; the most successful defense is to prevent attack; defense has half failed when attacks must be repulsed. The great enemies of termites are ants; and the functions of the soldiers seem to me to be to defend any openings in the nests by putting their heads in the way whilst the workers build fortifications. Those soldiers which have a saddle-shaped pronotum and well-developed mandibles are very sluggish, and seem quite useless when a nest is opened. It is the nests to which these belong that birds are most fond of; but while broken nests may be used to bait bird traps, unbroken nests seem sufficiently strong to resist the birds.

Those soldiers which have a saddle-shaped pronotum and rudimentary mandibles secrete a clear viscid fluid from a sac which occupies a great part of the head, and opens by a duct which passes down the rostrum. The soldiers may be seen to dab a little of the fluid on the antennæ of their enemies by a quick movement which is clearly a modification of the shaking movement so often seen in worker termites. By this means such enemies as ants are placed hors de combat when they do not, as they generally do, avoid these soldiers. But such a mode of defense would seem quite useless in dealing with birds

and mammals. However, all the species of the section to which *T. umbrinus* belongs traverse the jungle, returning home by daylight exposed in long lines which take an hour or more to pass one spot, the soldiers walking beside the laden workers. In most of the species the soldiers and workers retreat when disturbed; but in *T. longipes* the behavior is unusually active. The workers vanish at once beneath sticks and leaves; and if specimens be not quickly secured, they will soon be very hard to find. The soldiers, on the other hand, rush to the attack, not in line, but singly; climbing every leaf and stalk, they stand with unlifted rostrum challenging the enemy. But these species with rostrum and rudimentary mandibles are not the only ones which secrete a viscid fluid from the head. The soldiers of *T. foraminifer*, which have a saddle-shaped pronotum and long crooked mandibles, also have a minute orifice in the front of the head. In all the species of *Rhinotermes* the soldiers have a similar foramen and a shallow groove which runs from it to the tip of the labrum. *T. malayanus* has a similar minute foramen, the orifice of a sac occupying the middle of the head. Most soldiers of the fungus growers and also those of *T. sulphureus*, when angry, discharge a viscid fluid from large salivary vesicles opening into the mouth. The most remarkable form of orifice in the front of the head is in the section *Coptotermes*. The soldiers of both *T. gestroi* and *T. travians* have very large orifices in the front of the head from which, when angry, they emit a copious white viscid fluid which runs down to the mandibles. The soldiers of *T. gestroi* are very ferocious. The species is one which deliberately attacks and destroys live trees. The workers build up a thick earthy crust round the stem of the tree for the height of 7 or 8 feet from the ground; beneath this crust they leisurely seek out weak spots and penetrate to the center of the tree. If the crust be broken, the workers very quickly retreat; but the soldiers rush to the attack, a white milky fluid standing between their open jaws; they lift themselves up and then hammer their heads against the tree, producing a rattling sound. If left alone they soon retire under cover; but if one breaks into their retreat, out they come again in great excitement, hammering their heads, opening and shutting their jaws, and discharging their milky secretion. In the section of the fungus growers to which *T. bellicosus* belongs the workers run away to their subterranean passages when the nest is being opened, while the soldiers stay to defend the nest; generally the smaller soldiers are more active than the larger, for they run about while the larger occupy the crevices of the nest and the cavities of the fungus buds, where they wait and bite at anything which comes in reach. The soldiers of this group can generally produce the rattling sound. In this accomplishment *T. carbonarius* has reached the highest stage of development, for the soldiers can hammer in rhythmic unison. At first a few begin irreg-



ularly, then they get into time, and the others take it up. Every soldier in the exposed portion of the nest stands up and hammers with his head; the blow is given thrice in very quick succession, and then there is an interval of two seconds. The noise they produce reminds me of wavelets lapping on a shore. This trick of hammering with the head is seen in only a few species; it is clearly a modification of the shaking movement so often seen in workers.

I have not found a species without soldiers, though Dr. Fritz Müller found some in America. I have rarely found a nest without soldiers, though in *T. lobatus* I have done so. \* \* \*

To the workers I have not paid much attention. The amount of coloring and chitinization is correlated with the period during which they are exposed to light. A broad head, slender legs, and arched abdomen go with activity and the habit of foraging for food. A narrow head, short stout legs, and fusiform abdomen go with a sluggish habit. The workers not only collect the food and build the nest, but also nurse the young, and may be seen carrying the eggs and young larvæ to places of greater safety. In some species they certainly take care of the queens. \* \* \*

The structure and position of termites' nests are very various. They agree in having the outer part closed so as to exclude their great enemies, the ants; the entrances are generally few and well protected. There are, however, some exceptions to this rule, of which the most remarkable is the nest of *T. latericius*, which has two or three vertical shafts, an inch or two in diameter and about three feet deep, opening on the surface of the ground. *T. hospitalis* also has one or more large openings at the summit of the nest. Several species of the group to which *T. lacessitus* belongs, and which build round nests on the branches of shrubs, may also have several exposed openings into the nests.

The different groups of the genus *Termes* build nests of different characters; the most remarkable that I have seen are those of the fungus growers, so well described by Smeathman in the case of *T. bellicosus*. The nests of the American fungus growers seem unfortunately never to have been described. It was noticed by Smeathman that in some cases the nests of nearly allied species were more easily distinguished than the insects which built them. This is especially true of the species allied to *T. nemorosus*, which builds turret nests described by Smeathman. On the other hand, the appearance and shape of the nests are much modified by conditions; thus the mound builders can live without a mound in cultivated ground, where mounds are not permitted.

All the species whose soldiers have a distinctly saddle-shaped pronotum seem to use proctodeal discharges in the building of their nests. The fungus growers, on the other hand, do not do so, but

moisten the pellets of clay which they bring with fluid from their mouths. In species of *Coptotermes* and *Rhinotermes*, and in *Termes tenuior*, I did not see what manner of cement was used. *T. planus* lived in shallow chambers eaten in the wood, much after the manner of *Calotermes*, and had no buildings.

Observers in America and Europe have concluded that the same colony often possess several nests, only one of which is inhabited by fertile individuals, whose eggs and young are carried to the other nests. I do not doubt that this is so with a few species; I believe it to be so with *T. gestroi*; nevertheless it is not so with the great majority of species which I have collected. Further, the evidence for such conclusion is, for the most part, negative, and therefore to be treated with great caution. As the search for king and queen goes on hour after hour without success, exhausted patience induces strong wish for a conclusion; and it is then that the difficulty arises of keeping the influence of wish from upsetting the even balance of judgment.

---

EXPLANATION OF THE PLATES.

PLATE I.

Nest of Bornean white ant.

PLATE II.

- |         |                                |                               |       |
|---------|--------------------------------|-------------------------------|-------|
| Fig. 1. | <i>Hodotermes Havilandi</i> .  | Soldier.                      | × 3.  |
| 2.      |                                | Under side of soldier's head. | × 3.  |
| 3.      | <i>Calotermes domesticus</i> . | Soldier (side view).          | × 6.  |
| 4.      |                                | Under side of soldier's head. | × 8.  |
| 5.      |                                | Imago.                        | × 6.  |
| 6.      |                                | Wing.                         | × 6.  |
| 7.      | <i>Termes natalensis</i> .     | Soldier.                      | × 4.  |
| 8.      |                                | Under side of soldier's head. | × 5.  |
| 9.      |                                | Imago.                        | × 4.  |
| 10.     |                                | Wing.                         | × 2.  |
| 11.     | <i>Termes vulgaris</i> .       | Soldier.                      | × 8.  |
| 12.     |                                | Under side of soldier's head. | × 8.  |
| 13.     |                                | Imago.                        | × 3.  |
| 14.     |                                | Wing.                         | × 1½. |
| 15.     | <i>Termes incertus</i> .       | Soldier.                      | × 8.  |
| 16.     |                                | Under side of soldier's head. | × 8.  |
| 17.     |                                | Imago.                        | × 4.  |
| 18.     |                                | Wing.                         | × 2.  |
| 19.     | <i>Termes travians</i> .       | Soldier.                      | × 10. |
| 20.     |                                | Under side of soldier's head. | × 12. |
| 21.     |                                | Imago.                        | × 6.  |
| 22.     |                                | Wing.                         | × 3.  |
| 23.     | <i>Termes translucens</i> .    | Soldier.                      | × 4.  |
| 24.     |                                | Under side of soldier's head. | × 6.  |
| 25.     |                                | Imago.                        | × 4.  |
| 26.     |                                | Wing.                         | × 3.  |

## PLATE III.

- Fig. 27. *Termes aqualis*. Soldier.  $\times 10$ .  
 28. Under side of soldier's head.  $\times 10$ .  
 29. Neotenic queen.  $\times 5$ .  
 30. *Termes planus*. Soldier.  $\times 8$ .  
 31. Under side of soldier's head.  $\times 8$ .  
 32. Imago.  $\times 10$ .  
 33. Wing.  $\times 8$ .  
 34. *Termes tenuior*. Soldier.  $\times 8$ .  
 35. Under side of soldier's head.  $\times 8$ .  
 36. Imago.  $\times 8$ .  
 37. Wing.  $\times 8$ .  
 38. *Termes dubius*. Soldier.  $\times 8$ .  
 39. Under side of soldier's head.  $\times 12$ .  
 40. Imago.  $\times 8$ .  
 41. Wing.  $\times 6$ .  
 42. *Termes sulphureus*. Soldier.  $\times 8$ .  
 43. Side view of soldier's head.  $\times 10$ .  
 44. Imago.  $\times 8$ .  
 45. *Termes dentatus*. Soldier.  $\times 8$ .  
 46. Side view of soldier's head.  $\times 8$ .  
 47. Imago.  $\times 6$ .  
 48. Wing.  $\times 4$ .  
 49. *Termes bilobatus*. Soldier.  $\times 6$ .  
 50. Side view of soldier's head.  $\times 6$ .  
 51. Imago.  $\times 6$ .  
 52. Wing.  $\times 3$ .  
 53. *Termes nemorosus*. Soldier.  $\times 6$ .  
 54. Side view of soldier's head.  $\times 6$ .  
 55. Imago.  $\times 6$ .  
 56. Wing.  $\times 4$ .

## PLATE IV.

- Fig. 57. *Termes setiger*. Soldier.  $\times 6$ .  
 58. Side view of soldier's head.  $\times 8$ .  
 59. Imago.  $\times 6$ .  
 60. Wing.  $\times 4$ .  
 61. *Termes comis*. Soldier.  $\times 8$ .  
 62. Side view of soldier's head.  $\times 8$ .  
 63. Imago.  $\times 8$ .  
 64. Wing.  $\times 5$ .  
 65. *Termes foraninifer*. Soldier.  $\times 8$ .  
 66. Side view of soldier's head.  $\times 10$ .  
 67. Imago.  $\times 8$ .  
 68. Wing.  $\times 6$ .  
 69. *Termes fuscipennis*. Soldier.  $\times 8$ .  
 70. Side view of soldier's head.  $\times 8$ .  
 71. Imago.  $\times 6$ .  
 72. Wing.  $\times 3$ .  
 73. *Termes regularis*. Soldier.  $\times 6$ .  
 74. Imago.  $\times 6$ .  
 75. Wing.  $\times 4$ .

76. *Termes singaporiensis*. Soldier.  $\times 10$ .  
77. Side view of soldier's head.  $\times 10$ .  
78. Imago.  $\times 6$ .  
79. Wing.  $\times 3$ .  
80. *Termes lacessitus*. Soldier.  $\times 8$ .  
81. Side view of soldier's head.  $\times 8$ .  
82. Nymph.  $\times 6$ .  
83. *Termes hospitalis*. Soldier.  $\times 8$ .  
84. Side view of soldier's head.  $\times 8$ .  
85. Imago.  $\times 6$ .  
86. Wing.  $\times 3$ .

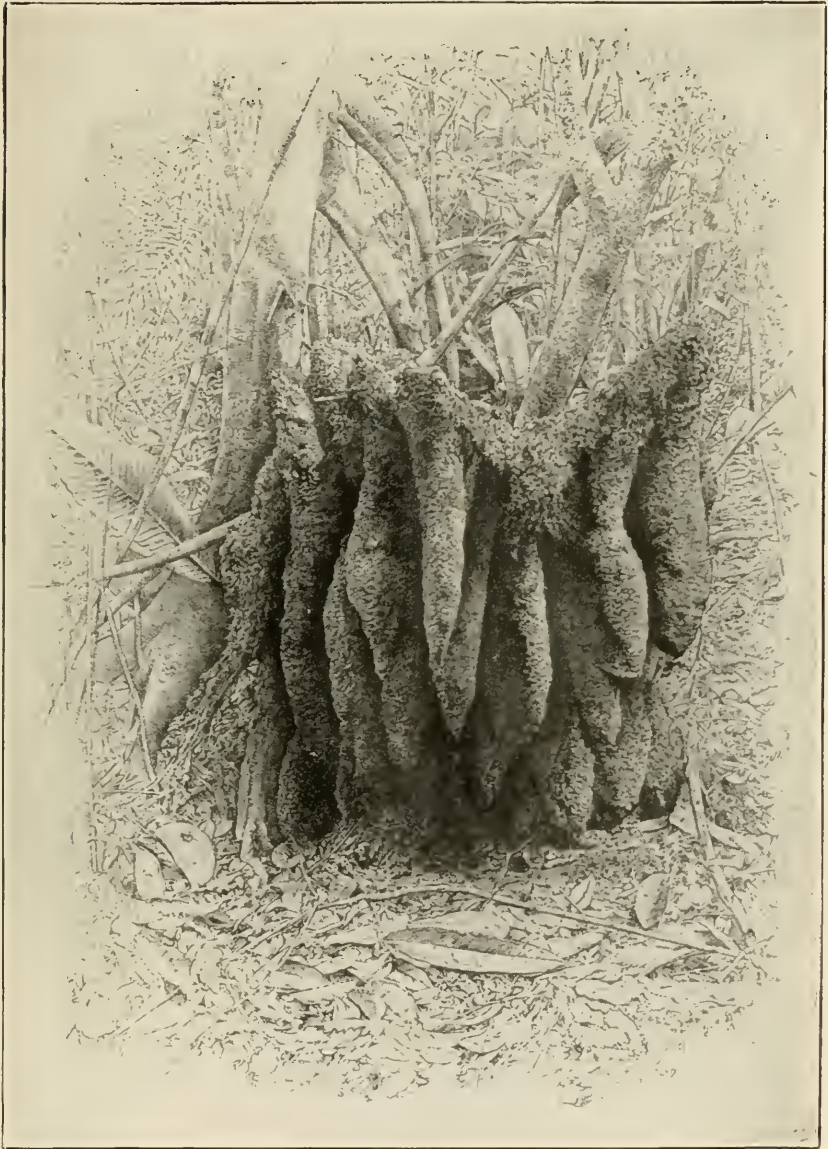

NEST OF BORNEAN WHITE ANTS.



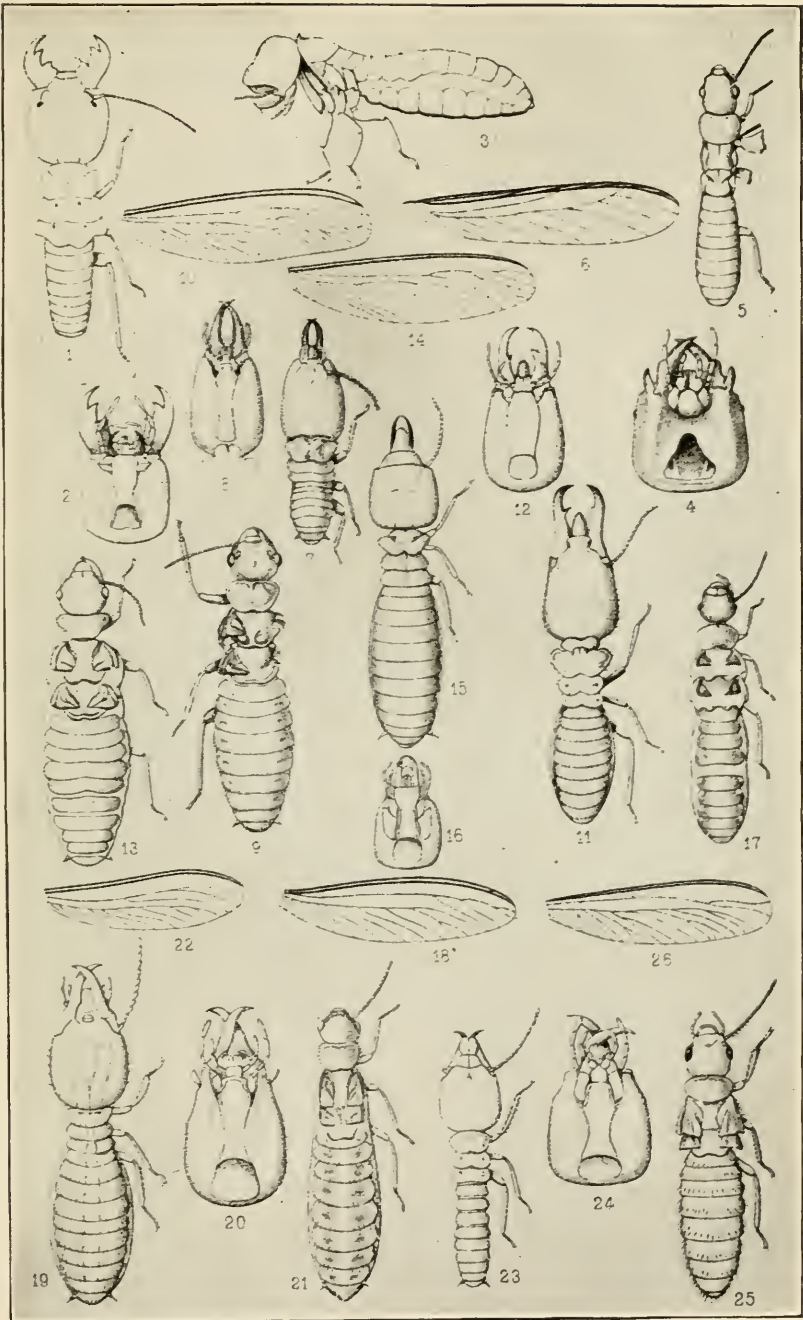

MALAYAN AND SOUTH AFRICAN TERMITES.

Explanation of plate on page 676.





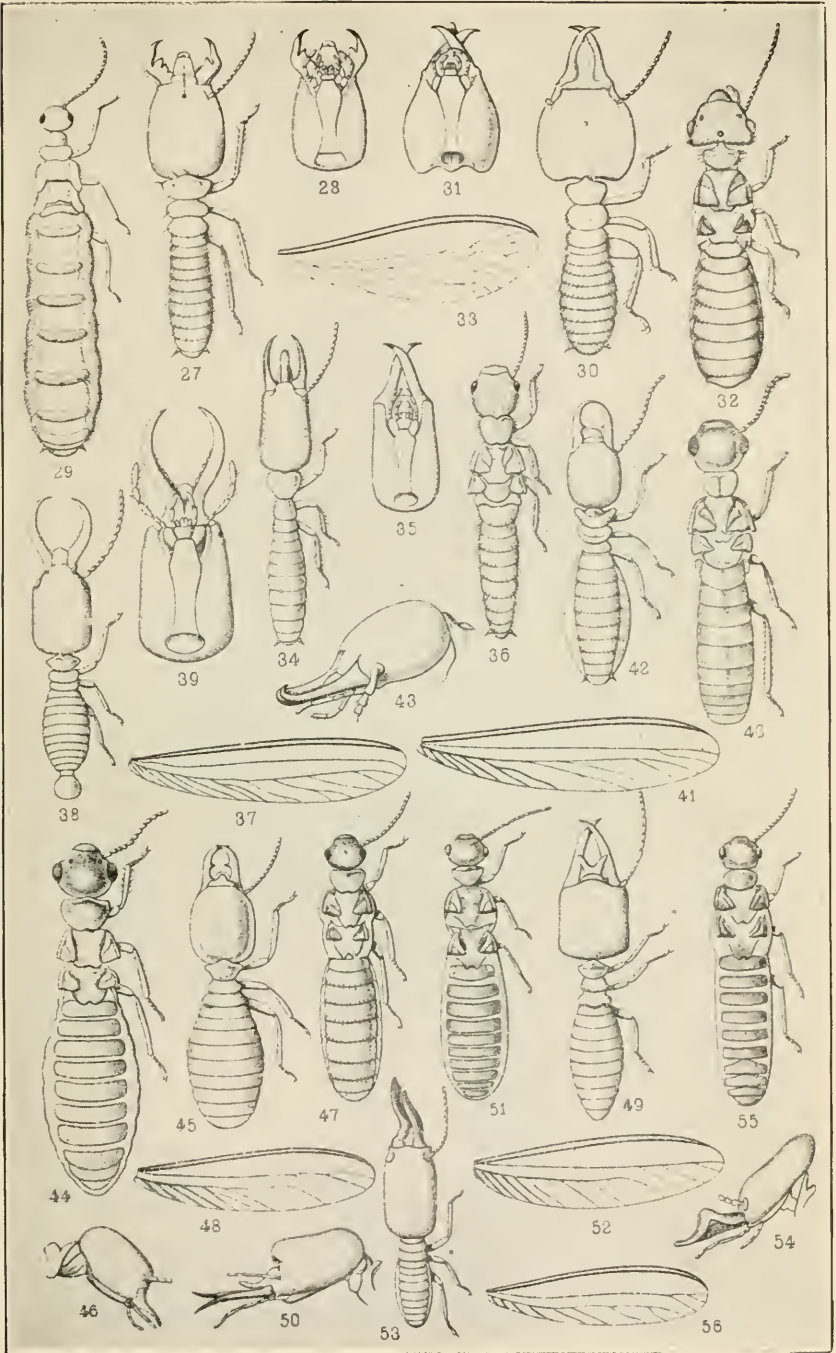

MALAYAN AND SOUTH AFRICAN TERMITES.

Explanation of plate on page 677.



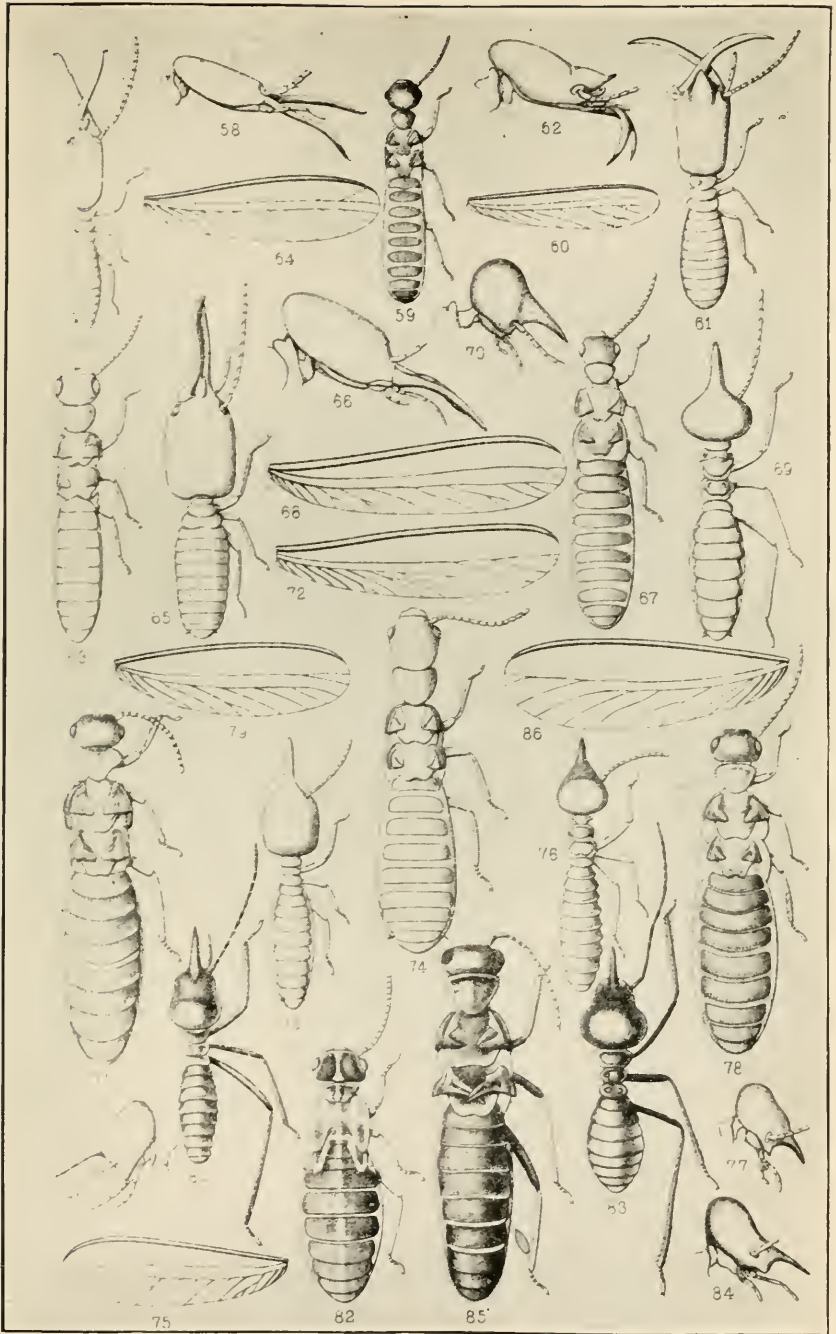

MALAYAN AND SOUTH AFRICAN TERMITES.

Explanation of plate on page 677.



## THE WANDERINGS OF THE WATER BUFFALO.<sup>a</sup>

---

The Indian government has recently formed dairy farms to supply milk and butter for the use of the troops. The fine breeds of Indian cattle are used in these dairies, but cow buffaloes are also kept on account of the richness of their milk. Europeans sometimes object to use it, as the domesticated buffalo is often kept as a sort of scavenger to the cow byres of the Indian cities, and eats the litter and refuse of the farmyards. But properly fed the buffalo is by no means the bovine pig which it becomes when kept in Hyderabad or Benares. It is not only a first-class dairy animal, but the strongest beast of draft in the world except the elephant. Great areas of rich river delta and marsh in three continents are maintained in cultivation by buffaloes when no other animal could possibly be used to plow the rice fields or drag carts over and through miles of liquid mud. The value of this, probably the latest of all large animals to be domesticated, is so well known in the East that it has for centuries past been carried to places so remote from its original home and apparently so inaccessible that the extent of its involuntary migrations in the service of man has a peculiar interest. Besides this it is one of the very few domesticated animals which, like the yak and the gayal (possibly a tame form of the gaur), are still found in their original wild state, with form and habits scarcely altered. The wild buffalo is among the most dangerous and formidable of the big game of India, never hesitating to charge when wounded, and noted for the persistency with which it seeks to destroy the person who has injured it. Its natural home is in the grass jungles and swamps of India, Nepaul, and Assam. It is also found wild in the island of Formosa. It is a huge black beast, with no hair, a skin like black gutta-percha, immense horns, sometimes measuring more than 12 feet along the curve, though not spreading like a shield over the forehead as in the Cape buffalo, but set like a pair of scythes on each side of its head. A bull stands 6 feet high at the shoulder—eighteen hands, that is; its bulk is enormous, and its great spreading feet are well adapted for walking in the swamps. By choice it is semi-aquatic. A herd will lie for hours in a pool or river with just their eyes, horns, and great snub noses above water. Anyone who blunders

---

<sup>a</sup> Reprinted from *The Spectator*, August 31, 1901, pp. 278-279.

onto a buffalo in a wallowing-hole and frightens it out may be excused for imagining that he has just come on a mud volcano at the moment of eruption.

This is the real buffalo—called in India the arnee—and not to be confounded with the gaur or the banteng, the wild oxen of India and the Far East. It will be seen that the buffalo in its wild state is limited to a not very large area, namely, the country south of the Himalayas, and extending for some distance, the limits of which are not perfectly known, in the territory of the Indo-Chinese states. Yet this enormously powerful and fierce animal has been so completely domesticated by the Hindoos that the tame herds are regularly driven out to feed in the same jungles in which wild buffaloes live, the bulls among which will often come down and, after giving battle to the tame bulls, annex the cows for a time and keep them in the jungle. The only striking difference in appearance between the tame and wild buffalo is that the horns of the former do not grow to the size attained in the wild specimens, and alter their curve and pitch. Mr. Lockwood Kipling notes the curious effect of the growth of long horns above a herd of these animals, no two buffaloes having them of the same pattern. Traces of the lateness of the date of their apprenticeship to the service of man are seen in their power of self-defense and combination when threatened with attack by tigers or leopards, by their mating with the wild stock, and by the uncertainty of their temper, especially toward Europeans. Wherever they are used by oriental races these outbreaks of savageness are always in evidence from time to time when the white man encounters them. In China they have been known to chase Europeans when the latter were riding, as well as when passing on foot. They will do the same in India, in Egypt, and in Burmah. Yet in India they are generally taken out to pasture by some small boy, who is their tyrant and master, and will protect him, their calves, and themselves from the tiger. An account appeared recently in *Country Life* of the use of a herd of these animals to beat the jungle for a wounded tiger which had killed a native. The buffaloes were driven up and down for a whole day, beating the ground in a compact body, until they found the tiger, whose hiding place was shown by the excitement of the herd, at which it charged almost as soon as they observed it, and was shot by the guns following them.

As a beast of draft the buffalo has astonishing powers of hauling heavy traffic over bad roads. It can plow in mud over its hoofs. It is most docile. It can swim a river going to and from work, tow barges along canals and streams, sometimes walking in the shallow water by the banks, like the horses did on the Lower Thames before the towpath was made. It will eat anything it can get, and asks only for one indulgence, a good hour's swim or mud bath in the middle of the day. The rice fields which feed so great a percentage of the popu-

lation of eastern Asia could scarcely be cultivated without its aid, and it is so valuable as a dairy animal that the percentage of butter in its milk equals that of the best breeds of English dairy cattle. The result is that it has become an equal favorite with the Hindoo, the Arab, and the Chinaman, and plays a most important part in the agriculture of the Lower Nile Valley.

The great distance from its original home in India at which we now find the buffalo established is evidence that the animal has a history of an exceedingly adventurous kind, were it possible to trace the story of its travels. Starting from the Indian jungles, and then domesticated on the Indian plains, this erstwhile wild beast has reached and been domesticated and plays a most important part in Egypt, Palestine, southern Italy and the Campagna, the south and east of Spain, Hungary, Turkey, and western Asia as far as the borders of Afghanistan. By some unknown route it has reached the west coast of Africa, and is established as a beast of draught and cultivation on the Niger. It has traveled far up the Nile, and will go farther, for it would be invaluable on the great swamps Fashoda way. In the Far East the Chinaman has made it his own peculiar pet, having, it is believed, first learnt its value in the rice grounds of the south. It has been taken to Japan, where it now works in the rice grounds; to the Philippines and the islands of the Malay Archipelago; and there is no doubt that it would be useful in British Guiana. Possibly the Italians who are crowding over into America will introduce it in the Lower Mississippi Valley; but it is by nature a brown and yellow man's beast, and only appreciated in Europe by the South Latin races.

How did the buffalo get from India to Africa? Who first took it to Egypt? How did it get from Egypt round to the West Niger? And who brought it to Italy, and from whence? All these are most interesting questions, and as the distance of time which has elapsed since the animals were introduced into Europe does not fall beyond the historic period, may possibly be answered. In Egypt, for instance, there exists a pictorial record on the tombs and elsewhere, covering many thousands of years, in which pictures of animals play an important part. If the first appearance of the water buffalo in these paintings were noted, the date of its importation from India to Egypt would be known. From inquiries kindly made by M. Maspero at the suggestion of Lord Cromer, it appears that nowhere in the long "picture history" of ancient Egypt does the water buffalo appear. The African buffalo is seen there; not so the domesticated Asiatic one. This is very interesting negative evidence that this domesticated animal was not known in ancient Egypt. It is surmised, probably rightly, that it was imported after some great epidemic of cattle plague, or it may have been taken from the west coast of India up the Euphrates Valley, and thence down the Jordan Valley to Egypt. Arab dhows

have for ages done a regular trade in carrying horses from the west coast of India to the Persian Gulf. It is probably one of the oldest forms of shipping which exists, and the Arabs who now ship horses from Bombay to the Persian Gulf may have been in the cattle trade in very early days. It is also probable that in the era of Hindoo maritime enterprise these creatures were taken both to the Far East and to the east coast of Africa. The circumstances which led to their introduction into Italy and Spain are probably to be found in some existing record; but it is not one generally known, the nearest surmise being that they may have been given to a Longobardian king with other animals by the chief of a horde of Asiatic invaders. They were not known in Italy in Roman times. But if they had been introduced as recently as the camels which are still used on one of the royal estates in Tuscany (an enterprise due to the Medici), the fact would probably have been matter of common knowledge.





WATER BUFFALO IN NATIONAL ZOOLOGICAL PARK, WASHINGTON CITY.



## ON THE PRESERVATION OF THE MARINE ANIMALS OF THE NORTHWEST COAST.

---

By WILLIAM H. DALL.

---

I have been requested by the Secretary of the Smithsonian Institution to record any facts in my possession bearing on the preservation from extinction by the hand of man of the various marine animals of the northwestern coast of America.

The preservation of wild animals in menageries and zoological gardens is necessarily of a most temporary nature, since many of them will not breed in captivity and all require the greatest care to preserve them in even moderately good health. It is very rare that we find among the carnivores a large mammal which has reached a point as near domestication as the lion, of which a reasonable supply of cubs bred in captivity are generally available. Even the European bison, which has been preserved in the forests of eastern Europe in small numbers for several centuries in a state as near as possible to that of untroubled nature, are now, it is reported, on the point of extinction from disease and weakness due to constant inbreeding.

Unless actually domesticated this is what may be reasonably expected to occur in time with any limited number of uncivilized men or wild animals. If the stock is kept pure it will perish from breeding in and in; if it is mingled with other blood the original type gradually fades out. We may, therefore, look forward to a time, nearer perhaps than we suspect, when all large animals and most of the attractive wild birds will be known only from pictures or the rare and precious specimens preserved in museums. Those animals capable of domestication in large numbers, like certain deer, will alone survive to represent to future generations the varied fauna of large wild animals of to-day. The boreal swamps may still afford a refuge to some of the more hardy fur-bearing creatures, but the use of furs taken from wild animals will by that time be wholly superseded by still more beautiful products of the loom.

The lovers of nature and the uncommon (which includes the greater part of the civilized races) can not contemplate such a state of affairs with equanimity. Like the man who committed suicide because he

was tired of buttoning and unbuttoning, the average citizen would find such monotony unendurable. The day when circuses are shorn of their attendant menageries will sensibly diminish the gayety of nations and deprive the youthful of a most cherished source of amusement and instruction. Without its bears and wolves, leopards and tigers, elephants and hippopotami, the natural world would have far less interest and the distant day of its final extinction would be palpably foreshadowed.

It is said of man that he shall inherit the earth; and as population grows this prophecy is gradually being fulfilled. Though there are deserts in the south, swamps and tundra in the north, and mountain ranges everywhere, where man can not find a subsistence or create a home, no doubt can exist that in the fullness of time all productive regions of the earth's surface will be occupied; and only such animals in the wild state as can secure subsistence from the most inhospitable areas can be expected to survive.

The sea, however, is different. Here man, who began by fishing from the shore, then whitened the ocean highways with the canvas of his sailing ships, and now blackens them from the smoking funnels of the sea tramp or the majestic liner, is distinctly a temporary sojourner. He embarks upon the sea because he must cross it, or carry the goods of others across it; because for a brief season he enjoys trying his wit and strength against the forces of nature and defying her barriers; or because he seeks to wrest her treasures from the sea. However crowded the continents may be, it seems improbable that men, away from their shores, will ever make their homes upon the sea.

There is then some hope for the marine animals. There will always be food for them, always a vast extent of ocean for them to roam in undisturbed, and no man will grudge them the occupancy of the reefs and sandbars which they may seek, at certain seasons, to bring forth their young or lie untroubled in the sunshine.

Whatever may be the ultimate fate of the purely terrestrial animals, in a sense competitors with man, there is no sufficient reason why the marine animals may not survive on the globe as long as man himself. The latter, from a geological standpoint, but recently feral himself, still preserves in great strength certain primal instincts. There is a legend of two Englishmen who, hunting in the wilds of central Asia, during the temporary absence of the seraphic guardians, ignorantly came to pitch their tent in the Garden of Eden. Waking with the light of dawn when the descendants of the animals named by our first parent were in primeval amity, wandering peacefully over the green slopes before him, one of the intruders looked from the door of his tent and shouted to his comrade, "Wake up! wake up! Here is a chance to kill something!" Whether this be authentic or not, it is certain that the desire to kill is one of the most general and strenuous

instincts in man, even of the highest civilization. For unnumbered centuries his subsistence depended upon his ability to kill, and his very existence upon the power to restrain, by killing first, those who would kill him. It is not to be expected that these instincts can be changed or eliminated in a few generations. Nevertheless, the desire to kill for the sake of killing has been modified in the more intelligent of civilized men to a desire to kill for some definite purpose, such as the accumulation of property, the protection of domestic animals, or the elimination of vermin.

We may hope that the more intelligent body of those who make and enforce the laws may so restrain the less intelligent, who kill in wantonness or for a trifling gain, as to defer the extinction of the sea animals indefinitely. It is entirely possible, though up to the present time effective measures of protection have, so far as international law would admit, been carried out solely for one animal—the fur seal. Others, like the sea otter and salmon, have been legislated for, but it is universally believed on the northwest coast that no honest attempt to enforce this legislation has ever been made, and certainly none has been efficient. The prospect would indeed be dark if we could hope for nothing better than the conditions which have heretofore obtained.

But there is no reason why conditions should not improve, and the writer believes that if the American public were fully aware of the present state of things they would insist on a change; and if any general appreciation of what the present destructiveness implies could be brought about, the merest commercial self-interest would force a reform in the absence of other motives.

The marine animals which may be considered in this connection are as follows:

- The sea elephant, *Macrorhinus angustirostris*;
- The walrus, *Rosmarus obesus*;
- The sea lion, *Eumetopius stelleri*;
- The lesser sea lion, *Zalophus californianus*;
- The fur seal, *Callotaria ursina*;
- The hair or harbor seal, *Phoca largha*;
- The ringed seal, *Phoca fetida*;
- The harp seal, *Phoca granlandica*;
- The saddleback seal, *Histiophoca fasciata*;
- The bearded seal, *Erignathus barbatus*;
- The sea otter, *Enhydris marina*.

The fur seal has been the subject of so much writing and has excited so much popular interest from its commercial value and other causes that it will not be further referred to in this discussion, except to say that there is no question in the mind of anyone qualified to judge that if the destructive pelagic sealing were stopped, the seals would, in the course of eight or ten years, increase so as to restore the valuable industry now approaching extinction.

The sea elephant, formerly ranging from the vicinity of San Francisco, at Point Reyes, to the west shore of the peninsula of Lower California, is believed to be, if not actually extinct, at least reduced to a few individuals which are finding a temporary refuge among the reefs of Lower California. No one knows of any living specimens and the species, for present purposes, may be left out of consideration.

The bearded seal is supposed to occur very rarely on the coast of Eastern Siberia near Bering Strait. It is a common Atlantic species and may be merely a straggler in the Far West. The saddleback, a remarkably handsome and very rare animal, is believed to be confined to Kamchatka, the Okhotsk Sea, and the Kurile Islands. These two may also be dismissed from our reckoning.

The harbor seal is common in the colder waters of the coast, and colonies occur where the glaciers of southeastern Alaska drop their shattered ice blocks into bays and inlets. The mass of the species, however, is more northern and frequents the region of Bering Strait and the polar sea, especially about the edges of floe ice. It is a small species and largely utilized by the natives of those coasts for many purposes.

The ringed seal, a somewhat larger and handsomer animal, exists under nearly the same conditions and is hunted by the natives for the same purposes.

The harp seal, a much larger animal, is also of great importance to the native population and occupies the same region, though it never occurs in the vast numbers which make its pursuit by the Newfoundland sealers of commercial importance in the Atlantic.

These three are speared through the ice, at their blowholes in winter, or caught in nets ingeniously spread under the ice by the aid of long poles. They are shot or lanced near the edge of the floe in spring, and supply food, oil for fuel, soles for foot wear, coverings for boats, and a multitude of other articles essential to the existence of the native population. The number killed, though large in the total, is not so great as to disturb the balance of nature; and with the rapid decrease of the native population, due to introduced diseases, it will be less and less, year by year. They do not exist at present in numbers sufficient to tempt commercial slaughter, and so we may regard these species at least as practically safe under existing conditions.

The lesser sea lion is a native of the coasts of California, where it exists in large rookeries at a few places, especially on the Farallones Islands—fortunately a Government light-house reservation. Here they are not disturbed, though every few years a foolish agitation arises among the fishermen of San Francisco calling for their destruction on the ground that they are destroying the salmon, or other fish. No one has ever found a piece of salmon in the stomach of a sea lion

in the wild state, and the danger appears to be wholly imaginary, as the sea lions have existed as long as the fish, and, until man with his disregard of the future and his desperate endeavors to get rich rapidly, entered the field prepared to capture and kill wholesale for immediate profit and the subsistence of nations beyond the sea, there was fish enough and to spare. However, the sea lions are in no immediate danger, and a better knowledge of their food and habits will probably remove what seems to threaten in the future.

The great sea lion of Steller has been less fortunate and his fate has been curiously bound up with the sea-otter fishery, now in such a state of decay as to be almost negligible. The sea lion, in the absence of the larger hair seals, has been the chief reliance of the Aleutian otter hunters for the hide, with which they cover their hunting kyaks. This hide is far inferior to that of the seal, and must be renewed every year. Without sea-lion skins the hunters could not go to sea on their perilous hunting trips among the reefs for the precious otter fur. Control of the supply of sea-lion hides means more or less control of the hunting. So competing traders attacked the sea-lion rookeries, partly to get hides to trade to the hunters or supply their own fleet of kyaks; partly to destroy those they did not need, so that competitors for trade should not be able to get sea-lion skins, and thus should have their business crippled.

The shy and elusive otter in the strenuous competition was soon generally killed off that the trade has diminished to a point where it is dying for want of skins. The natives, diminishing at an astonishing rate from measles, influenza, and other introduced diseases, are obliged to earn a living otherwise than by hunting. So the devastated sea lion rookeries are slowly recovering, and as their value and number are too small to tempt destruction on commercial grounds by the whites, we may regard the danger point as passed. The burly monarch of the island reefs is no longer in need of immediate protection.

The strong arm of Russia, guided by expert knowledge, has provided and efficiently protected a reserve on the Commander Islands, where the sea otter is now flourishing and a valuable industry slowly reviving. When a single good skin is worth \$400 at any furrier's, the whole power of the United States, as at present exerted in such matters (witness the buffalo in the Yellowstone Park), is incompetent to protect or preserve an animal or an industry against the poacher on her own soil. Spain may recoil in defeat, but the poacher boldly scorns the guardians of a reservation and jingles the dollars in his pocket. We may therefore give up the case of the sea otter as hopeless. Democracy has its disadvantages.

There remains the case of the walrus. There were, a few years ago, several small herds of this animal existing at little-frequented points in Bering Sea. This animal seems to be able to change its habits. At

least, the main walrus population has always lived on the edges of the floe ice, which advances in winter to the latitude of the Pribilof Islands and retreats with the melting pack ice in summer to the Polar Sea. Yet certain small colonies have in historic times always existed in certain localities winter and summer, perhaps attracted by an exceptional abundance of their favorite food. A small bunch of walrus for many years occupied Walrus Island, of the Pribilof group, but this was an assembly of a peculiar character. It was entirely composed of old males driven away from the herds by the competitive valor of their younger and more active congeners, and forming a sort of old gentleman's club, existing in torpid dignity away from an atmosphere of irritating disrespect. We are informed that this retreat is now untenanted and the assembly scattered or destroyed.

The walrus feeds on clams, sea snails, and other mollusks of the kind which frequent sand banks in shallow water. These are rooted out of the sand by the aid of the powerful tusks and swallowed whole, with a stone or two to aid digestion. The shells pass through the body in the natural way and are discharged on the rookeries, largely in an unbroken state. It is therefore necessary that the herd should have a large area to dig over, as such enormous animals must require a large supply of food. They appear to increase slowly, and being, when well fed, of a rather sluggish disposition, fall an easy prey to the hunter intent on ivory or oil. I understand that the Secretary of the Treasury has forbidden the wanton shooting of these animals by travelers bound to Nome, who, while waiting on board ship for the ice to open, formerly amused themselves in this way. The number of the animals has very greatly diminished owing to destruction by whalers unable to get any whales, who a few years ago attempted to make up for other deficiencies by filling up with walrus oil and ivory. This has not been done of late years owing to the great distress the absence of walrus brought upon the natives of the Arctic coast, who were very dependent upon them for food and coverings for their boats. The diminished numbers of the animals, of whom 11,000 were killed in a single season at the height of the fishery, have also tended to make their pursuit unprofitable.

It is evident that the walrus can not be preserved in confinement, nor could a herd flourish in a restricted area. Their preservation, in the case of the small herds referred to as stationary, is a very simple matter. If they are let alone, they will take care of themselves, as hitherto. If protected from the poacher, they need no other care. The way to keep them in existence is not to kill them. They will do the rest.



## SOME PRIVATE ZOOS.<sup>a</sup>

---

By F. G. AFLALO.

---

Those who freely criticise the scant accommodation allotted to many inmates of the London Zoo are, no doubt, expressing a very commendable sentiment; but they do not appear to realize that it is a case of little or nothing, and that, circumscribed as it is by public property, not a fraction of an acre can be added to that corner of the Regent's Park already covered by the familiar paddocks and buildings. It is another matter altogether when private gentlemen, with the right tastes and opportunities, give over their parks to beautiful and interesting animals of all lands, and accord them, amid enchanting surroundings, a liberty which, little more restricted than in their natural homes, knows little of the perils of nature and nothing of the cruelties of sport. The majority of men and women like to surround themselves with favorite animals; and if we must sometimes regret the proclivity when we see larks beating their wings vainly against jealous bars, we can have nothing but appreciation for such private zoos as I have selected for notice in the present article. There is, as a rule, no ulterior motive beyond the mere pleasure in seeing these animals well and happy in their new homes, though in some few instances, it is true, the fostering of science or sport has been at the bottom of such experiments in acclimatization.

The Duke of Bedford seems, with his hundreds of wild deer and antelopes, cattle, sheep, and goats, which luxuriate at Woburn in amazing herds, to have taken over the scientific research once projected, but since abandoned, by the society of which he is president. The Jardin d'Acclimatation in Paris is similarly interested in the practical side of introducing useful or ornamental exotic animals. Sport, again, has been responsible for the introduction into these islands, at more or less remote dates, of the pheasant, red-legged partridge, and carp.

If we have borrowed, we have also lent; and our red grouse, once found only in the United Kingdom, has succeeded so well in parts of Belgium and Germany that new game laws are now necessary for its preservation on the continent. The only government, however, which

---

<sup>a</sup> Reprinted, by permission, from Pall Mall Magazine, London, Vol. XXV, September, 1901.

concerns itself with such operations is, if we except the more or less private undertakings of more than one reigning sovereign, that of America, in which the game and fisheries departments of the chief States devote considerable sums of money to the introduction of suitable game beasts and birds.

Private enterprise takes with us the place of public usefulness, and we thus have in our midst a number of sportsmen and naturalists who extend their protection to foreign animals, and spend their money in giving them every chance of doing well amid their new surroundings. I have chosen four of these zoos, situated in widely different parts of the country, to illustrate some points of interest in the management of such establishments, and all of these I have visited personally. My scheme does not include the aforementioned preserve of Woburn, nor have I seen the famous Japanese deer at Powerscourt, where Viscount Powerscourt was the first to acclimatize that graceful species as a park animal. At the same time, I think it may be shown that these four animal sanctuaries—they are Tring, Vaynol, Haggerston, and Leonardslee—on the resources of which I have drawn for these notes, have succeeded under sufficiently marked differences of soil, climate, and situation to encourage anyone who may contemplate establishing yet another reserve in no matter what district of England. Each of them has its prominent feature, and in each there is some lack that we find supplied in one or other of the rest.

I suppose that of all four Leonardslee comes nearest to the ideal for the purpose. Sheltered by the South Downs its sandy soil throws up a luxuriance of flowering shrubs and appears to favor all manner of foreign trees, no matter whence Sir Edmund Loder brought them in the seed. Its hilly tracts are in parts so wild that London might well be 400, instead of merely 40, miles away. Its climate is more equable than would be expected so near the home counties; and the higher portions of the estate are bracing, while the lower hold an abundant supply of water that not even the caprices of its famous beavers can divert.

Touching Tring, there is, I think, nothing of extreme importance to be noted with reference to its climate or situation; but Vaynol and Haggerston present diametrically opposite physical conditions, their only drawback in common being, perhaps, a too heavy rainfall in the wet season. While the latter lies between the imposing slopes of Snowdon and the Menai Strait, amid scenery of great variety, and in a soft western climate, the more northerly estate is on the lowlands of the Northumbrian coast, exposed to every cold and violent wind that blows across the neighboring North Sea, while equally bitter winds reach it from the southwest, straight from the Cheviot Hills, that are often snow clad until early summer.

The feature of the Hon. Walter Rothschild's collection at Tring is,



WILD CATTLE. VAYNOL.



THE HON. WALTER ROTHSCHILD, M. P., DRIVING ZEBRA.



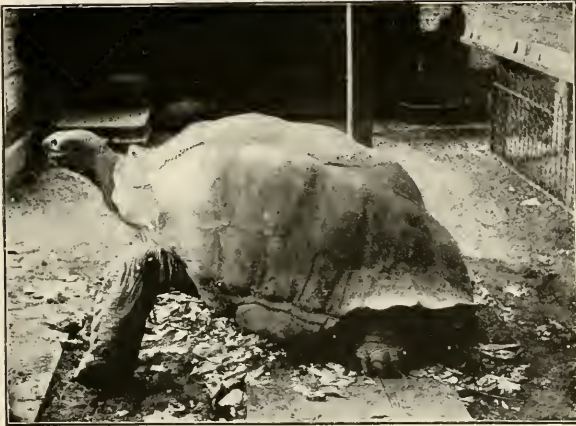

GIANT TORTOISE AT TRING.



A CORNER OF SIR E. LODER'S MUSEUM.



of course, the excellently ordered private museum, the stocking of which keeps his collectors busy in all parts of the world. Mr. Rothschild has, indeed, deposited so many of his animals in the London Zoo that it is not easy to form any adequate idea of all the curious creatures that he has brought to England without visiting both. It is in London, indeed, that we find most of his gigantic tortoises, rescued from a near extinction in the southern islands, where once, cut off from the evil-doing of man and his dogs, they contrived to grow to such mighty measurements. Tring Park has, however, its interesting inhabitants as well; and kangaroos and emus roam so obviously at large that, but for the more pleasing variety in the vegetation of the northern hemisphere, one might well picture it a corner of Australia. At Haggerston, on the other hand, there is the prospering herd of American bison, of which Mr. Christopher Leyland takes every care; while at Vaynol Mr. G. W. Duff Assheton Smith has his wild white cattle.

Visitors to Leonardslee, too, will find just such an assemblage of horned game as, roaming at liberty up and down hills intersected by game paths, might be expected to conjure up pleasant scenes to a famous traveler whose rifle made top score in an all-England eight. The Leonardslee Museum, too, though less systematic in its arrangement than that at Tring, is more purely sporting, showing a fine collection of its owner's trophies.

Unless, as in the case of the wild white cattle, there is any technical objection to interbreeding, it is in most cases usual to allow the different kinds of animals to intermingle without restraint; and now and then, even in the seclusion of cage or paddock, some strange partnerships are the result. At Vaynol, for instance, a young Sambur deer and pony are boon companions, and have a field to themselves; while in the building in which Mr. Assheton Smith keeps his pumas and monkeys there is a most entertaining trio in the shape of two white wolves and a little Malayan bear. Whenever the horseplay of the wolves becomes unendurable, the bear, not without a parting cuff, makes his way up a tree and out into the open air above, whither, since dogs can not climb, the wolves are unable to pursue.

It will easily be understood that so varied a collection of animals as inhabits each and all of these zoos includes individuals of various degrees of shyness, and not all the animals may be seen at the first attempt. Only on my sixth night at Vaynol, for instance, did I see the wild roe deer that hide away in the dense cover beneath the heronry; and the Leonardslee beavers are still more secretive than the prairie dogs that burrow in their sandy inclosure on the hill close beside the house, baffling all but the most skillful and patient photographers. It is to Mr. R. B. Lodge that I am indebted for the accompanying picture of one of these interesting little hermits, most of which utter their angry squeal and dive below as soon as the intruder comes within 20 yards of their watchtowers.

Haggerston lies, as I have said, on the bleak coast of Northumberland, and the visitor must alight at the little station of Beal, changing out of the express, which ignores it, into a slower local train that runs from Newcastle to Berwick. The lodge gates adjoin the station, and on either side of the winding track that leads to the castle are inquisitive wapiti, bison (both pure and half-breed), gnus, and other strange creatures. The crowning success of acclimatization is fully attested by the numbers of young animals intermingled with their sires and dams (for the Nilghai antelopes often produce twins); and there are the calves of the zebu and, one had almost added, of the gnu, but that, in spite of its ox-like exterior, the gnu is an antelope and its young are in consequence styled fawns.

Although we see before us miles of wire fence and inclosed buildings, there is liberty, too, for the Haggerston animals; and at one turn of the road Mr. Tait, who has charge of them all, points out a rock-wallaby reclining lazily in the branches of a low tree, leafless this January afternoon. These rock-wallabies are also very fond of the cedars, which they ascend to a great height. Bennett's wallabies and great kangaroos gaze stolidly at the emus and black swans, maybe with memories of a distant home that they have no cause to regret. Right through the grounds goes the sluggish Low, its waters holding numbers of small trout, and the moaning of the North Sea can be heard whenever the wind blows from the east. The emus and rheas (their South American cousins) have bred less satisfactorily these past three years, a falling off which Mr. Leyland attributes to excessive rains, and more particularly to late frosts, during incubation. This year, however, there are again some young emus. Japanese apes run free in a large inclosure, but no families have so far blessed their captivity. Mr. Leyland tells me that he started this wonderful collection some twenty years ago in Wales, with emus, kangaroos, pheasants, waterfowl, and various small birds. Some ten years ago their owner moved north and took with him his herds of wapiti and bison. It is with the last named that animal lovers must always associate his work. Thanks to American railroad enterprise and Indian greed, the bison has long been a vanishing type. Indeed, the absolutely wild condition knows it no longer, which sad fact makes it the more gratifying that the Haggerston herd is slowly but surely on the increase. Mr. Leyland has crosses between bison bull and Highland cow, and the heifers have for two generations been bred back to pure bison bull. The larger birds kept in the paddocks include no fewer than five kinds of cranes; but only one, the Demoiselles, have ever mated, and even they did not hatch.

Having visited Tring in December, Haggerston in January, and both Leonardslee and Vaynol in the loveliest time of spring, I offer comparisons with all reserve. Tring, however, if it does not perhaps





YOUNG SAMBRU AND PONY. VAYNOL.



PRAIRIE DOGS. LEONARDSLEE PARK.





WAPITI STAG. HAGGERSTON.



EMUS AND YOUNG. HAGGERSTON.



offer any striking variety of scenery, never, on the other hand, looks as dour as the north country, in the barrenness of which the master of Haggerston has made his paradise. In addition to its sheep and cattle and shire horses, domesticated types that stand apart from the wilder subjects of these notes, Tring has close on a hundred Japanese and fallow deer, about thirty kangaroos and wallabies, rather less than a score of emus, and some rheas and cassowaries. These great struthious birds do not all accommodate themselves to captivity with the same thoroughness. Thus, while the emus hatch out regularly year after year, the cassowaries never get beyond the laying stage.

The private museum at Tring, which was mentioned above, must be one of the finest of its kind in the world. I have met Mr. Rothschild's collectors at work in southern islands and continents; and on one occasion I traveled some 12,000 miles in company with mysterious chests addressed to him, the contents of which I subsequently had the pleasure of seeing in their new quarters. In the working rooms of his museum he studies and writes about the pheasants and other groups of birds in which he takes a special interest, and his pheasant-ries contain half a dozen species, including the elegant pheasant, not found elsewhere alive in Europe except at Berlin. It would be unpardonable to write, however briefly, of Mr. Rothschild and Tring without some allusion to his successful domestication of the Burchell zebra, which he was in the habit of driving in harness. Those who know anything of zebra morals will admire his enterprise. Those who have a regard for him and his work will not be sorry to hear that he has handed the contumacious brutes over to a cousin who resides in France.

I have already admitted that my visits to both Leonardslee and Vaynol were made under seasonal conditions that showed those beautiful places at their fairest. The memory of Leonardslee on the last day of April is as of a corner of the Kew hothouses gone astray, with all their wealth of rhododendrons and camellias, a wild conglomeration of half the zoological and botanical regions that lie between the Tropics and the Poles. Here we stand beneath a 90-foot fir tree from the icy north and gaze on prancing gazelles from the Arabian Desert; we move into the slighter shade of dwarf firs from the Atlas Mountains; wallabies from Australia and axis deer from the East gaze wonderingly at us from behind bushes of American origin. The trees and shrubs, like the beasts and birds, have apparently made themselves quite at home on a soil so poor that nature would seem to have destined it for the maintenance of nothing above mean and lowly heaths. A closer inspection of the Leonardslee Zoo reveals the thorough wildness of the animals. Here, within 5 miles of Horsham, representative groups of the fauna of three continents run as free as in their own lands. The skill of the vet can never reach them; Dallmeyer's tele-

photographic lens alone could imprison the image of more than one or two of the most trusting. Only when their race is run and their perverted morality calls for the euthanasia of an unerring rifle does their owner seek them out and end each doomed career. The most interesting members of this assorted family—the eight beavers of Montana stock—do not put in an appearance until daylight wanes, and those with thoughts of evening engagements in town and return trains must be content with the sight of their wonderful dams and take the engineers themselves on trust. Further negative and positive evidence, too, of their restless energy they may find in the spectacle of splendid trees either sheathed with iron mail against those untiring teeth or else gnawed through more than a moiety of their thickness. The wood that is given to them every day provides both nourishment and exercise, since the saplings of beech or fir are propped upright in the earth, and the beavers have to work hard for each meal of bark. Nature has furnished the beaver so that it must either labor unceasingly or sicken to the death, and work they do beyond any other creature on earth. No strikes, no eight-hours' creed; but an astonishing application to the work of destruction. The woods provided for the colony at Leonardslee are not of the hardest, but Sir Edmund Loder has in his museum a mighty fragment of British oak, the iron hardness of which was no match for their teeth. Indeed, one would not at first sight gather the meaning of that unobtrusive specimen of damaged wood, hidden away as it is in that jostling crowd of elephant, boar, tiger, antelope, goat, and gazelle, all brought back by the owner from the sands and snows of four continents. The Leonardslee beavers have so dammed the water in which they make their home, that no visitor would be likely to trace unaided its original course to the sea. Nature is, however, sometimes stronger than even the beavers, and there was a sorry spate two years back that washed the beavers a distance of 2 miles into some eel traps, from which they were presently rescued and restored to their anxious owner. Old female beavers occasionally make mischief in the otherwise peaceful little colony: for like old hen grouse, they grow very jealous of their juniors once they have done with the softer emotions of life, and their pugnacity is incurable. When their case is thus past remedy, they are eliminated. An operation is also sometimes needed for the overgrowing teeth, and it takes five men to hold a self-respecting beaver still enough for the purpose, one gripping each leg, while a fifth keeps the ever-ready teeth gripped on a piece of soft wood. It would, I imagine, take a Mussulman to photograph beavers in the natural state. The ordinary patience of Western photographers is not equal to the ordeal. But your Mussulman would uncomplainingly sit beside his subject's dwelling for a month or two, never leaving his post for such petty considerations as rest or refreshment, and he would, with a whispered "Inshallah!" of



BISON BULL. HAGGERSTON.



CASSOWARY. TRING.







TELEPHOTOGRAPH OF STAG. SURRENDEN.



KANGAROOS. LEONARDSLEE.



eternal hope, but otherwise without a murmur, waste dozens of plates, and at length success would be his.

At the antipodes of shyness, as of homeland, are the great kangaroos. Now, the kangaroo is in its own country anything but confiding. Its impressive 20-foot leaps have kept me on hands and knees, with a heavy Winchester rifle slung over my neck, by the hour, and it never reposed in me that perfect trust which would have enabled an easy shot. Fluking kangaroos at 300 or 400 yards is not exhilarating sport, as anyone might understand if he tried catapulting grasshoppers at 50. The conditions as to movement and size of the target would approximate. At Leonardslee, however, the only rifle that ever breaks the stillness is that with which Sir Edmund Loder practices at his private ranges; and the beasts have got to know and disregard its voice. So the kangaroos come quite close to even the stranger, and have in consequence no secrets from the camera. The Japanese deer, on the other hand, which seem to have learnt their leaping tricks, remain out of focal range, and nothing but the telephotograph, one of which Mr. Walter Winans has kindly sent me from his deer park at Surrenden, will avail. The big game of Leonardslee, however, is usually collected on a high, grassy plateau on the farther side of some pheasant coverts, and our sudden appearance round a bend sends herds of browsing mouflon and Barbary sheep, in a moment of forgotten confidence, prancing over the sky line. Among the rarities mention should perhaps be made of a pair of Marica gazelles, the only living specimens, I believe, in Europe.

The best known protégés of the Squire of Vaynol are perhaps his wild white cattle, of Sir John Orde's old Kilmory stock with a cross of Athol bull. Visitors to the Zoological Gardens during the past year or so must have noticed the Vaynol cow, with her little white calf by a Chartley sire. The remaining herds of British wild cattle are not more than three or four in number, and those at Vaynol were established there by the present owner. Though never aggressive, they are very wild in the sense of resenting the close approach of strangers, as the unsatisfactory result (given at the head of this article) of several hot days of stalking them in various parts of the park will bear witness. There is usually a herd of deer mingled with the cattle, and both graze close to the house and round the lake. Just before my stay, a cow had come to grief right under the windows, and had to be shot; and for several nights after the event a mighty bull fight took place in the moonlight on that spot—an episode that might perhaps have been valued more at a less restful hour of the twenty-four. The calves are noticeably whiter than their elders, which seem to assume a varying degree of yellow or cream-color as they advance in years. Of hares, Vaynol has three kinds (the English, Scotch, and Irish), and, for all I should care to swear to the contrary, about three

million of them. There are other dwellers in the park, however; and there is room for them, seeing that the wall inclosing it runs a good 8 miles under its *chevaux-de-frise* of slate. There are Indian pigmy cattle (a very recent addition), sheep from Iceland and St. Kilda, emus, rheas, herons, wild roe, and an appalling abundance of game and domestic stock that would break the heart of a census enumerator. Then, too, there are the wild boar recently presented by His Majesty the King. I assisted (in the French sense of the word) from the security of a high wall in their liberation from the crates in which they had traveled overnight; and they are now accommodated in an ideal piggery—fourteen acres of dry and sloping woodland fenced in and overlooking the carriage drive—which Mr. Assheton Smith had specially constructed for their reception. Of all that disbanded Windsor herd, none, I trow, will find better quarters. Vaynol has no museum, for the Squire likes his animals alive; but there is a *bijou menagerie*, from which the London Zoo might learn. The monkey house, for instance, has optional outdoor playing grounds, reached by way of trees and a tunnel; while the golden and imperial eagles are able to stretch their wings in large inclosures, and look very different from the pictures of misery usually presented by these great fowl in captivity. And this, I take it, is the striking note of difference between the private and the public zoo. The latter must always, whether it be the property of a scientific society or whether it be run as a syndicate investment, be conducted on economic lines that promise a return on capital sunk in its construction and upkeep. The private zoo, on the other hand, is kept up solely for the comfort of the animals and the pleasure of the owner in seeing them happy and prosperous. There is no question of restricted quarters, insufficient food, inadequate artificial heating or ventilation. As much as possible is left to nature, and the rest is very carefully adjusted in close imitation of her best conditions in the lands from which these attractive strangers were originally brought.



MARICA GAZELLE. LEONARDSLEE.



DEER. VAYNOL.



# THE NATIONAL ZOO AT WASHINGTON,<sup>a</sup> A STUDY OF ITS ANIMALS IN RELATION TO THEIR NATURAL ENVIRONMENT.

By ERNEST THOMPSON SETON.

## I.

At the beginning of this century the continent of North America was one vast and teeming game range. Not only were the buffalo in millions across the Mississippi, but other large game was fully as abundant, though less conspicuous. Herds of elk, numbering 10,000 or 15,000, were commonly seen along the Upper Missouri. The antelope ranged the higher plains in herds of thousands; whitetail deer, though less gregarious, were seen in bands of hundreds; while bighorn sheep, though still less disposed to gather in large flocks, were rarely out of sight in the lower parts of the eastern Rockies, and it was quite usual to see several hundred blacktail in the course of a single day's travel.

But a change set in when the pioneer Americans, with their horses, their deadly rifles, their energy, and their taste for murder, began to invade the newly found West.

The settlers increased in numbers, and the rifles became more deadly each year; but the animals did not improve in speed, cunning, or fecundity in an equal ratio, and so were defeated in the struggle for life, and started on the down grade toward extinction.

Aside from sentimental or æsthetic reasons, which I shall not here discuss, the extinction of a large or highly organized animal is a serious matter.

1. It is always dangerous to disturb the balance of nature by removing a poise. Some of the worst plagues have arisen in this way.

2. We do not know, without much and careful experiment, how vast a service that animal might have done to mankind as a domestic species.

The force of this will be more apparent if we recollect how much the few well-known domestic species have done for the advancement of

<sup>a</sup> Reprinted, by permission of the author and of The Century Company, from *The Century Magazine*, vol. lix, March, 1900; vol. lx, May, 1900. Copyrighted, 1900.

our race. Who can decide which has done more for mankind, the cow or the steam engine, the horse or electricity, the sheep or the printing press, the dog or the rifle, the ass or the loom? No one, indeed, can pronounce on these, yet all on reflection feel that there is reason in the comparisons. Take away these inventions, and we are put back a century, or perhaps two; but further, take away the domestic animals, and we are reduced to absolute savagery, for it was they who first made it possible for our aboriginal forefathers to settle in one place and learn the rudiments of civilization.

And it is quite possible, though of course not demonstrable, that the humble chuckie barn-fowl has been a larger benefactor of our race than any mechanical invention in our possession, for there is no inhabited country on earth to-day where the barn fowl is not a mainstay of health. There are vast regions of South America and Europe where it is *the* mainstay, and nowhere is there known anything that can take its place, which is probably more than can be said of anything in the world of mechanics.

Now, if the early hunters of these our domestic animals had succeeded in exterminating them before their stock was domesticated, which easily might have been, for domestication succeeds only after long and persistent effort and, in effect, a remodeling of the wild animal by select breeding, the loss to the world would have been a very serious matter, probably much more serious than the loss of any invention, because an idea, being born of other ideas, can be lost but temporarily, while the destruction of an organized being is irreparable.

And we to-day, therefore, who deliberately exterminate any large and useful, possibly domesticable, wild animal, may be doing more harm to the country than if we had robbed it of its navy.

This is the most obvious economic view of the question of extermination. But there is another, a yet higher one, which, in the end, will prove more truly economic. We are informed, on excellent authority, that man's most important business here is to "know himself."

Evidently one can not comprehend the nature of a wheel in a machine by study of that wheel alone; one must consider the whole machine or fail. And since it is established that man is merely a wheel in the great machine called the universe, he can never arrive at a comprehension of himself without study of the other wheels also. Therefore, to know himself man must study not only himself, but all things to which he is related. This is the motive of all scientific research.

There is no part of our environment that is not filled with precious facts bearing on the 'great problem,' and the nearer they are to us the more they contain for us. He who will explain the house sparrow's exemption from bacteriological infections, the white bear's



freedom from troubles that we attribute to uric acid in the blood, or the buffalo's and the flamingo's immunity from the deadliest malaria, is on the way to conferring like immunities on man. Each advance of science enables us to get more facts out of the same source, so that something that is studied to-day may yield a hundred times the value that it could or did ten years ago; and if that source of knowledge happens to be perishable, one can do the race no greater harm than by destroying it.

The Sibylline books were supposed to contain all necessary wisdom; they were destroyed, one by one, because the natural heir to that wisdom did not realize their value. He did waken up at last, but it was too late to save anything except a fragment. What Tarquin did to the books offered by the Cumæan Sibyl, our own race in America has done to some much more valuable books offered by nature. To illustrate: Each animal is in itself an inexhaustible volume of facts that man must have, to solve the great problem of knowing himself. One by one, not always deliberately, these wonderful volumes have been destroyed, and the facts that might have been read in them have been lost.

It is hard to imagine a greater injury to the world of thought, which is, after all, the real world, than the destruction of one of these wonderful unread volumes. It is possible that the study of "man" would suffer more by the extinction of some highly organized animal than it did by the burning of the Alexandrian library. This is why men of science have striven so earnestly to save our native animals from extinction.

In 1878 there were still millions of buffalo in the West. That year the Northern Pacific Railroad opened up the Missouri region, and the annual slaughter was greatly increased. In 1882 there were still thousands of buffalo. In 1884 all were gone but a few small, scattered bands. In 1885 there were probably less than five hundred buffalo left alive in the United States. In 1886 an expedition fitted out by the Government secured with great difficulty enough specimens to make the mounted groups in the National Museum, and it was then clear that unless the authorities took immediate and vigorous steps, the buffalo, within a year or two, would cease to exist.

About this time there appeared a number of articles by well-known observers, calling attention to the fact that the buffalo's fate was also awaiting, in the near future, all our finest animals, the probable order of extinction being buffalo, elk, antelope, moose, bighorn sheep, mountain goat, mule deer, Virginia deer; and the farthest probable date for the ruthless consummation was put at twenty years hence. It required no great argument to convince the public of the truth of these writers' main statements. It was obvious that no possible good was to be gained by exterminating these harmless animals, for the

love of slaughter, not the need for their skin, flesh, or range, was the incentive; and the public, though not yet able to look on these animals as the student does, nevertheless realized that it was about to be robbed of something valuable by a few mean-spirited and selfish hunters.

Additional point was given to the obvious moral by the circumstance that, through its far-reaching system of correspondence, the Smithsonian Institution was continually receiving gifts of living animals, which, for lack of space to keep them, had either to be turned into dead specimens or given away to outside zoos, or else returned to their donors.

This was the state of affairs in 1887, when the newly appointed Secretary of the Institution, Mr. S. P. Langley, who, though an astronomer and a physicist, had been very strongly impressed by the fact that all our largest and most interesting native animals were rapidly approaching extinction, conceived the idea of securing a tract of country, as primitive as possible, that might be made a lasting city of refuge for the vanishing races. This was the main idea, when first Mr. Langley went before Congress to urge the establishment of a national zoological park.

In all ages it has been the custom of potentates to keep a collection of wild animals for their amusement, and the American people, being their own ruler, had numberless precedents before them when urged to make this much-needed collection of animals.

In such a case the advantage of a monarchy is that only one man must be convinced, whereas in the republic the consent of a majority of seventy millions had to be obtained.

This took time. Fierce battles had to be fought with ignorant and captious politicians. One objected that he did not see why the people should pay "to have the Nebraska elk and Florida alligators cooped up." If they had to spend money for it they would want things they could not see at home—dog-faced baboons, kangaroos, man-eating tigers, etc. Another, a fervent patriot, objected to any money being spent on exotic species, as it was contrary to the spirit of the Constitution to encourage or import foreigners!

Altogether the Secretary of the Smithsonian found it no easy bill to carry, though it was indorsed by nearly every scientist and educator in the country.

After three years of persistent effort, involving vastly more worry than the management of the whole Smithsonian Institution for three times that period, Mr. Langley succeeded in carrying both Houses of Congress over the successive stages of ridicule, toleration, and favorable consideration, to the point of accepting and providing for the scheme.

An appropriation was made for a national zoological park to be established in the District of Columbia for the "advancement of

science and the instruction and amusement of the people," as well as a city of refuge where those "native animals that were threatened with extinction might live and perpetuate their species in peace."

An appropriation of \$200,000 was made, but it was clogged with several irksome conditions. One-half the expense was to be paid by the District of Columbia, thereby giving the commission a control which changed the plan, making the collection more like the ordinary menagerie. No animals were to be bought, which was much like a rich man building himself a picture-gallery, and saying, "Now, if my friends choose to present me with pictures, all right, I'll house them; but I've done enough for myself in building the gallery." And yet, though falling short of its promoter's original wish, the scheme has notably progressed, and no one who is capable of measuring the future of the institution can doubt that in founding this park, where those "native animals that were threatened with extinction might live and perpetuate their species in peace," Congress has done more for the learning, science, and amusement of the nation than it would in expending a much larger amount in a university, a theater, and a choice library combined; for the fields of the three are already well covered, but the park, by preserving the nation's heritage of wild animals, has opened important regions of biological research and zoological art.

He was a wise old farmer who said to his son, "John, make sure of your land, and everything else will take care of itself." The whole appropriation was wisely expended in securing land, and although scientists have not the highest reputation for business sense, the Park's projector was enough of a business man to secure land that would now fetch at least ten times what was paid for it ten years ago.

It comprises 167 acres of land, beautifully diversified with woods and streams, in the suburbs of the city of Washington—land which the Secretary had discovered years before when on rides for recreation, and the absolute fitness of which for the purpose in hand had been helpful in developing the original plan. It included the historical grounds and building of the Quincy Adams Mill and the classical old Holt House; but, better still, it secured a region that had always been a familiar resort of the native birds and quadrupeds of the District of Columbia, affording the best of expert testimony in favor of its salubrity. Mr. Langley recognized the merit of Mr. W. T. Hornaday, the well-known naturalist and taxidermist, and obtained his able and energetic superintendence during the earliest formative period of the park; and when he was called to duties elsewhere, Dr. Frank Baker took up the burden, and, under the direction of the Secretary, whose other duties have never interfered with the attention he has given to his own creation (the park), it has been carried on with all the success that could be expected under conditions of inadequate support.

Thus the National Zoo was founded under conditions that illustrate in a curious way the adage that the onlooker sees more than the players. Gæthe, the poet, surrounded by zoologists, was the first to point the true way for zoological science; it was for Franklin, the philosopher-printer, to teach his contemporaries how a perfect fire-place might be made; and so also Langley, the physicist, though surrounded by zoologists, has been the first to discern the pressing need of the study of American zoology.

The circumstances which led up to the idea were then unusual, as the plan itself was unique. There have been many menageries in which the animals were confined in box cages, and there have been many game parks where the various animals inclosed have wandered at will, with no barrier but the outward wall of the grounds; but this was to be the first zoological collection in which each kind of animal was to have a park of its own, where it could live as its race should live, among natural surroundings, with as little restraint as was compatible with its safe-keeping. The available acreage was barely enough to allow of the park scheme being extended to our more important native animals, so that the foreigners, particularly those from the tropic regions, are perforce managed as in the better class menageries elsewhere. But the glory of the place is in its individual parks. The fencing used is of the invisible kind, which rarely intrudes itself on the observer, and yet is strong enough to restrain the biggest buffalo. The ample stretches of woods and hills in each inclosure are unmarred by its lines, and the effect is as nearly as possible of seeing animals in the open.

Here they live, and no doubt enjoy their lives, and the observer has a chance to see them pretty much as they were in their native range. They group themselves naturally among trees and rocks, while the uneven ground induces attitudes of endless variety, and the close imitation of natural conditions causes the animals to resume the habits native to their lives in a wild state, thus affording the zoologist and the artist an opportunity for study never before equaled among captive animals.

The scheme is of course in its infancy yet. Wonders have been done with small appropriations, but many of its essential divisions have not yet been touched.

The antelope are provided with a little plain, and the deer have a small woodland where none can harm them or make them afraid. The buffalo has its little rolling prairie land, where it may bring forth its young without fear of the deadly omnipresent rifle, and regardless of its ancient foe, the ever-near gray wolf, that used to hang on the outskirts of the herds to kill the mother at her helpless time, or failing, to sneak around, ready, like an arrow in a bent bow, watching his chance to spring and tear the tender calf.

Here, indeed, the elk can bugle his far-sounding love-song in the

fall, without thereby making his stand the center of a rush of ruthless hunters. But many of our forest animals are still unprovided for. The bighorn sheep, the coast blacktail, the mule deer, the moose, and the mountain goat, as well as the grizzly bear, so rapidly following the buffalo, have as yet no refuge in the National Zoo.

It is too late to talk of such species as the great auk, the Labrador duck, and the West India seal; and in one year, or at most two years, unless Congress is willing to devote the price, or at least half the price, of a single big gun to it, the world will have lost forever the great Alaskan bear, the largest and most wonderful of its race.

## II.

The paddock immediately to the left on entering by the west gate of the Zoological Park brings us face to face with the first game animals that met the eyes of the Pilgrim Fathers, as well as those of the first settlers of Virginia; and it is tolerably certain that General Washington himself hunted the superb creature, the Virginia deer, over this very ground where it is now protected in the city of Washington and assured a little land of lasting peace.

Of all the American game animals the Virginia or whitetail deer is the greatest success as a species: that is, it has developed a better combination of hardiness, fecundity, speed, intelligence, keen wits, and adaptability than any of its relatives, and therefore maintains itself better in spite of the hunter. Its ancient range covered all of the United States east of the Rockies, as well as part of Canada, and to-day, notwithstanding guns, more numerous and deadly each year, there are whitetail deer in every part of their original range that still contains primitive woods.

In the list giving the probable order of extinction of our great game it will be seen that the Virginia deer stands last, despite the fact that it is the only one in that list whose home is in the thickly settled Eastern States. An incident will show the respect in which hunters hold the whitetail's gift for taking care of himself.

During October of 1899 I was staying at a camp on the east side of the Rockies. One morning a miner came in and reported that he had started four deer less than a mile away. Meat was scarce, and a hunter present became keenly interested.

"Whitetails or blacktails?" said he.

"Whitetails," said the miner.

"That settles it," said the hunter, resuming his seat by the fire. "If they were blacktails I'd get one within a mile, but a scared whitetail knows too much for me."

Although some of the deer in this paddock were born in the park, they show many of their wild habits. During the heat of the day they lie hidden among the bushes at the back end of their range; but early

in the morning or late in the evening they come to the watering place in the open, and if alarmed there they make for the trees, raising and waving as they go the "white flag" famous in all hunting lore.

This conspicuous action might seem a mistake in an animal that is seeking to escape unnoticed; but the sum of advantage in the habit is with the deer, or he would not do it, and its main purpose will be seen in one very important and frequent situation. A mother deer has detected danger; she gives a silent but unmistakable notification to her fawns by raising the "danger flag," a white one in this case; and then when she leads away through the woods they are enabled to keep sight of her in the densest thickets and darkest nights by the aid of the shining beacon, which is waved in a way peculiar to this species, and is not therefore liable to be mistaken for the white patch on any other animal.

In the sign language of the Indians the gesture for whitetail deer is made up of the general sign for deer, and then a waving of the flat open hand with fingers up, in imitation of the banneret as it floats away through the woods.

The form adopted for the whitetails' paddock is the result of experience. It was found that the animals became alarmed sometimes and dashed along the invisible fences, until suddenly met by another at right angles, and in this way several were hurt; but the improved plan of substituting obtuse angles, or a curve at the corners, causes them to be turned aside without injury.

One can not linger many minutes by the Virginia deer paddock without seeing some of those gorgeous Asiatics, the peacocks, walking about among the thicket or negotiating the wire fences with absolute precision whenever it suits their purpose to do so. The original half dozen birds have increased to a hundred, and the vast stretch (several hundred acres for them) of broken, wooded country is so perfectly suited to their needs that they give us a very good imitation of life in the Indian jungle. During the winter they roam about in promiscuous troops, but when the early spring comes and the cock is in his full regalia the mating instinct prompts them to scatter, and each family withdraws to a part of the jungle—the park, I mean—that is understood to be theirs, and to defend which the cock is ready to do battle with all feathered intruders.

Close to the deer paddock is a sunny open glade that was for long the special domain of one particular peacock. All about it is thick shrubbery, where the soberly dressed hens might have been seen quietly moving about, paying no obvious heed to their gorgeous partner, who mounted habitually on a little sand bank and spread and quivered his splendid jewelry in the sun, turning this way and that way to get the best effect, occasionally answering the far-away call of some rival with a defiant "qua," or replying to the dynamite explosions in a near



STUDIES OF ANTELOPE HEADS.









AN ANTELOPE POSE



THE CHRYSANTHEMUMS IN BLOOM.

quarry with a peculiar "bizz," the exact meaning of which I have failed to discover.

The daily display here and in many parts of the park gives the observer a chance to see the geometric perfection of the pattern made by the "eyes" when the peacock's train is raised. I reproduce a diagram of this made and published some years ago, when first I discovered the mathematics of this miracle in feathers. (Plate III.)

On crossing the road from the deer paddock toward the middle and more open part of the park the stranger is likely to come suddenly on a band of antelope. They seem to be grazing along their native upland prairie, not far from timber, and the visitor, if he have any of the feeling of the hunter-naturalist, is sure to feel the same little thrill that would come if he met with them thus in the wild West. He has ample time to admire and watch their changing and picturesque grouping before he realizes that between him and them is the slight but necessary wire fence. The effect of this invisible fence is seen on the animals if they have been undisturbed for some hours, as well as on the onlooker; for the sudden appearance of a human being close at hand, with no massive screening barrier between, causes them to behave for a moment much as they did when wild and free, and their startlement is expressed in pose and act exactly as it might have been on their native wilds; but they soon realize that they are safe and no harm is done. The erected mane and rump patch sink and the animals resume their feeding, leaving, nevertheless, on the air a peculiar musky odor that is quite strong when one is on their lee side.

Some years ago, while riding across the upland prairie of the Yellowstone, not very far from where these very antelope had been captured, I noticed certain white specks in the far distance. They showed and disappeared several times, and then began moving southward. Then, in another direction, I discovered other white specks, which also seemed to flash and disappear. A glass showed them to be antelope, but it did not wholly explain the flashing or the moving which ultimately united the two bands. I made note of the fact, but found no explanation until the opportunity came to study the antelope in the Washington Zoo. I had been quietly watching the grazing herd on their hillside for some time; in fact, I was sketching, which is quite the best way to watch an animal minutely. I was so quiet that the antelope seemed to have forgotten me, when, contrary to rules, a dog chanced into the park. The wild antelope habit is to raise its head every few moments while grazing, to keep a sharp lookout for danger, and these captives kept up the practice of their race. The first that did so saw the dog. It uttered no sound, but gazed at the wolfish-looking intruder, and all the long white hairs of the rump patch were raised with a jerk that made the patch flash in the sun like a tin pan. Every one of the grazing antelope saw the flash, repeated it instantly,

and raised his head to gaze in the direction where the first was gazing. At the same time I noticed on the wind a peculiar musky smell—a smell that certainly came from the antelope.

Some time later the opportunity came to make a careful dissection of the antelope's rump patch, and the keystone to the arch of facts was supplied. My specimen, taken in Jacksons Hole, was a male under six months old, so that all the proportions, and indeed the character, are much less developed than in the adult. (Plate III.)

The fresh skin was laid flat on a board, and then the pattern and mechanism of the rump patch were clearly seen. The hairs at the upper part of the patch (*A*) were  $3\frac{3}{4}$  inches long, grading to the center (*B*) and lower parts, where they were only  $1\frac{1}{2}$  inches long, all snowy white, and normally lying down flat, pointing toward the rear. At the point *B*, among the roots of the hair, was a gland secreting a strong musk. On the under side of the skin was a broad sheet of muscular fibers, which were thickest around *B*; they have power to change the direction of the hair, so that all below *B* stands out, and all above is directed forward. As soon, therefore, as an antelope sees some strange or thrilling object, this muscle acts, and the rump patch is changed in a flash into a great double disk or twin chrysanthemum of white, that shines afar like a patch of snow; but in the middle of each bloom a dark brown spot, the musk gland, is exposed, a great quantity of the odor is set free, and the message is read by all those that have noses to read.

Of all animals man has the poorest nose; he has virtually lost the sense of smell, while among the next animals in the scale scent is their best faculty; yet even man can distinguish this danger scent for many yards down wind, and there is no reason to doubt that another antelope can detect it a mile away.

Thus the observations on the captive animals living under normal conditions prove the key to those made on the plains, and I know now that the changing flecks in the Yellowstone uplands were made by this antelope heliograph while the two bands signaled each other, and the smaller band, on getting the musky message, "Friends," laid aside all precaution and fearlessly joined their relations.

This animal has five different sets of glands about it, each exuding a different kind of musk for use in its daily life, as a means of getting and giving intelligence to its kind. These are situated one on each foot between the toes, one on each angle of the jaw, one on the back of each hock, one on the middle of each disk on the rump, and one at the base of the tail.

Those on the jaw seem related to the sexual system, as they are largest in the buck; those on the rump, as seen, have a place in their heliographic code; and the purpose of the others, though not yet fully worked out, is almost certainly to serve in conveying the news. To

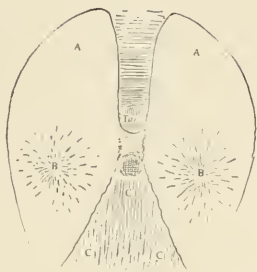
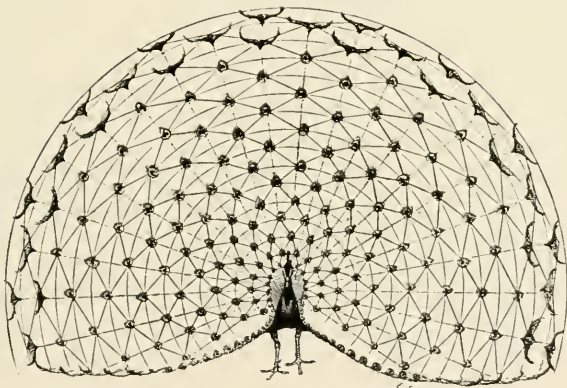

DIAGRAM OF ANTELOPE'S  
RUMP PATCHES.



DOG AND WOLF  
TYPE OF EYE.



PLAN OF THE PEACOCK'S TRAIN, TO SHOW THE GEOMETRICAL ARRANGEMENT WHEN  
EACH FEATHER IS PRESENT IN PERFECT CONDITION.

From Mr. Seton-Thompson's "Art Anatomy of Animals."



illustrate: An antelope passes along a certain plain, eats at one place, drinks at another, lies down at a third, is pursued by a wolf for half a mile, when the wolf gives up the unequal race, and the antelope escapes at his ease. A second antelope comes along. The foot scent from the interdigital glands marks the course of his relative as clearly for him as the track in the snow would for us. Its strength tells him somewhat of the time elapsed since it was made, and its individuality tells him whether his predecessor was a stranger or a personal friend, just as surely as a dog can tell his master's track. The frequency of the tracks shows that the first one was not in haste, and the hoek scent, exuded on the plants or ground when he lay down, informs the second one of the action. At the place where the wolf was sighted, the sudden diffusion of the rump musk on the surrounding sagebrush will be perceptible to the newcomer for hours afterwards. The wide gaps between the traces of foot scent now attest the speed of the fugitive, and the cause of it is clearly read when the wolf trail joins on. This may sound a far-fetched tale of Sherlock Holmes among the animals, but not so if we remember that the scent faculty is better than the sight faculty in these animals, while their sight faculty is at least as good as ours, and that, finally, if all this had been in the snow we also could have read it with absolute precision.

The pronghorned antelope, or prongbuck of books, is the only horned ruminant in North America that has only two hoofs on each foot. Nature's economic plan has been to remove all parts that cease to be of use, and so save the expense of growing and maintaining them. Thus man is losing his back or wisdom teeth since civilized diet is rendering them useless. The ancestor of the antelope had four hoofs on each foot, like a deer or a pig, but the back pair on each foot has been dropped. At an earlier step the common ancestor of antelope and deer had five well-developed toes on each extremity, but it seems that while this makes an admirable foot for wading in treacherous swamps, it is for mechanical reasons a slow foot; the fewer the toes the greater the speed. The deer still living in swamps could not afford to dispense entirely with the useful little hind or mud hoof. There they are still for bog use, though much modified from the original equal-toed type, more nearly shown in the pig. But the antelope, living on the hard, dry uplands had no use for bogtrotters, and exchanged them for a higher rate of speed, so that it now has only two toes on each foot.

The horse family went yet further, for they lived in a region where evolution went faster. They shunned the very neighborhood of swamps; all their life was spent on the firm, dry, level country; speed and sound feet were their very holds on life, and these they maintained at their highest pitch by adopting a foot with a single hoof-clad toe.

There is one other remarkable peculiarity of the antelope to note,

and that is its horns. The ox and sheep tribes of the world have simple horns of true horny material permanently growing on a bony core which is part of the skull. The deer have horns of branched form and of bony material sprouting from the head, but dropping off to be renewed each year. Our antelope is the only animal in the world whose weapons are of true horn growing on a bony core, as in the ox tribes, yet branched and dropping off each year, as in the deer.

It is now an axiom of science that not the smallest detail is without a distinct purpose, for which it has been carefully adapted after ages of experiment; yet long ago Darwin, the apostle of the belief, confessed himself puzzled by the form of the antelope's horns. It seemed as though a simple, straight spike would be so much more effective. If the great philosopher had been with me in the Washington Zoological Park that day, his puzzle would have been solved for him by two of the antelopes themselves. They were having one of their periodical fights for the mastery; they approached with noses to the ground, and after fencing for an opening they closed with a clash, and as they thrust and parried the purpose of the prong was clear. It served the antelope exactly as the guard on a bowie-knife does a Mexican or that on a foil does a swordsman, for countless thrusts that would have slipped up the horn and reached the head were caught with admirable adroitness in this fork.

And the inturned, harmless-looking points! I had to watch long before I saw how dangerous they might be when the right moment arrived. After several moments of fencing one of the bucks got under the other one's guard, and making a sudden thrust, which the other failed to catch in the fork, he brought his inturned left point to bear on the unprotected throat of his opponent, who saved himself from injury by rearing quickly, though it seemed to me that such a move could not have stopped a fatal thrust if they had really been fighting a deadly duel.

### III.

It is a common saying among keepers that, averaging one animal with another, a menagerie must be renewed every three years. Yet I know of one manager who kept most of his animals, those of Woodward's Gardens, San Francisco, alive, healthy, and happy from the beginning of his time to the end, sixteen years later, when the establishment was broken up, and the animals were ordered to be shot in their cages. The great secret of his success, he tells me, was caring for their minds as well as for their bodies.

It is a well known fact that lions and many other animals in traveling circuses are healthier and live longer than those in ordinary menageries. At first one might think that the traveling animals get more fresh air and exercise than the others. Yet this is not the case, for the circus cage is always very small and cramped. While traveling it is



usually shut up, and when showing it is in the tent, always a drafty, ill-ventilated, foul-smelling place. The great advantage of the circus is the constant change of scene—the varied excitements that give the animals something to think about, and keep them from torpid habits and mental morbidity.

It has long been known that caged animals, especially the highly organized kinds, suffer from a variety of mental diseases. Mr. Ohninus, the superintendent referred to, informs me that camels and several other species commonly end their cage lives in lunacy. The camels turned loose in Arizona some years ago were reduced at length to one old male. In course of time his solitary life affected his brain. According to local tradition, he went crazy, and used to attack every living creature near, until he was killed by a mounted cowboy whom he had pursued with murderous intent.

Captive bears are apt to fall into a sort of sullen despondency. Foxes and cats often go crazy, and no matter how obviously mental the disease, it is usually set down to hydrophobia, and the unanswered question is, How did they get it? Dogs that are constantly chained up commonly become sullen and dangerous. The higher apes and baboons rarely thrive in cages. Soon or late they become abnormally vicious, or else have a complete physical breakdown. All this is so human, and so emphasizes the great truth of evolution, that the wise keeper seizes on the cue, and in his management of his charges treats them like human beings of a lower development than himself.

Many a man shut up in a cell has saved his mind by inventing some trifling amusement. It is recorded that one set a daily watch on the movements of a spider. Another tried how many times he had to toss five pins before they fell in just the same way. Another tried to run 10 miles each day in his narrow limits. Yet another busied himself inventing new arrangements for the two or three articles of furniture in his cell. Many have paced up and down each day for a number of hours. And whatever they did, all alike were seeking to put in time, to while away the awful tedium of their monotonous lives, to respond to the natural craving for exercise, and to save their minds and bodies from actually withering from disuse.

If instead of "human captives" we read "wild animals" in all this, we shall have a very fair portrait of what we may see every day in an ordinary menagerie. Why does the elephant swing to and fro forever from his chain picket? Why does he gather from the floor all the straw he can reach, throw it over his back and over the stable, to be regathered later? Why does the squirrel enter and work for hours the aimless treadmill, and the marten leap listlessly half a day from point to point—floor, perch, slat, box; floor, perch, slat, box—again and again, with monotonous sameness day after day? Why does the lone ostrich waltz far more than does his wild kinsman that has many

admiring spectators of his own kind, and why do the fox and the wolverene trot miles and miles of cage front every day? Why does the bear roll and tumble for hours over the same old wooden ball as if it were a new-found chum; or, if no ball is supplied, swing back and forth on pivotal hind foot for hours each day? Why does the rhinoceros keep on forever nosing at some projection that his horn can almost fasten under, till it gets more and more elusive through the smoothening of perpetual use? Why do wolves and monkeys put in hours and hours over humble duties that in their wild state were the work of a few minutes at most? To all, the answer is the same as to the similar query about the man prisoner. They are putting in time. They are responding to the natural craving for exercise. They are trying to pass the tedium of their hopeless lives. They are doing anything—everything—their poor brains can suggest to while away the weary drag of dull, eventless days. Their bellies are well cared for, or at least are always plentifully cared for, but how few keepers have learned that in each animal is a mentality, large or small, that ought to be considered!

Here is where Ohminus scored. He tried to make their lives interesting. The excitement of the chase must necessarily be denied those animals whose nature prompts them that way, but one of his first and most successful moves was made in consideration of their special case. He divided the single meal of all flesh-eating animals in two; the same in quantity each day, but a light morning meal and a light afternoon meal. Thus, he "gave them something more to think about." It made two breaks in the day's monotony, and in time it unquestionably bore good fruit.

Another variation was made by changing them into new cages. An animal soon learns a cage by heart. He knows every bar and bolt, and every trifling roughness in wall or floor. He can walk to and fro without his eyes if need be. But putting him into a new cage is like opening to him a new life. Everything new and to be learned must naturally create new interests, and be of corresponding benefit, unless it has come too late.

There is a pathetic story of an old tiger that had passed his life in a traveling cage until in a railway accident his car and his cage alike were overturned and broken open. The tiger was unharmed, and he passed out through the broken grating, and for the first time since he left India as a cub he was free, standing untrammelled, with the whole world open to him. But all his splendid powers were gone or were dwarfed. He seemed appalled by the new responsibilities. After a moment's hesitation he declined the freedom that had come too late and crawled back again into his narrow cage, realizing that this was the only thing that he was fit for now.

One of the best expedients of all to enliven and brighten the lives of the caged animals is friendship with the keeper. There was no such



TIGER IN WRECK OF CAGE.



thing as solitary confinement in Woodward's Gardens. Every prisoner there had at least one powerful friend who was always near and ready to attend to all his wants, including the craving for sympathetic companionship which few animals are entirely without.

But all these allayments are mere expedients. The real plan is to restore the natural conditions. We are slowly grasping the idea, taught by the greatest thinkers in all ages, that the animals have an inalienable, God-given right to the pursuit of happiness in their own way as long as they do not interfere with our happiness. And if we must for good reasons keep them in prison, we are bound to make their condition tolerable, not only for their sakes, but for our own, because all the benefit that we can get out of them in bondage is increased in proportion as we slacken their bonds within the limits of judicious restraint.

If a Chinaman after going through Sing Sing were to say, "I have heard much of the high mentality, the attainments, and the refinement of the white race, but these seem to me merely a lot of sullen, stupid brutes," it would about parallel the case of an ordinary menagerie viewed by an ordinary onlooker. If we wish to enjoy the beauty of the animals, or study their development and learn how it bears on our own, we must see them living their lives. This can not be done in box cages, is very difficult in the wilds, and is easily possible only in a zoological park.

Occupation and plenty of good food are not the only things needful to a well-rounded life. No matter how cared for, fed, and housed, the occupants of every well-known monkey house were formerly afflicted with coughs, colds, and lung diseases, that made their abode like a hospital and carried off the inmates at plague rates, so that but few monkeys saw their second season in confinement. All sorts of remedies were tried without avail; hothouses with natural accessories, continual medical treatment, and all, failed to lower the death rate. At last it occurred to the monkey keeper of a European zoo that all this coddling would be very bad for a human being, so why not bad for monkeys? He decided to treat them like fellow-creatures: he discarded the stuffy hothouses; he gave his monkeys free access to the pure air and the sun, in a cage as large as he could get it, large enough to give room for exercise, and the result was that coughs and colds began to disappear. The death rate rapidly fell; each month and year that passed gave fuller indorsement to the idea. In short, he had learned the art of monkey-keeping.

Each advance of knowledge has emphasized these great principles that the lower animals are so like ourselves that to keep them in health we must give some thought to their happiness, and in aiming at both we must accept the ordinary principles obtained from study of ourselves.

These are among the considerations that shaped the scheme of the

National Zoo at Washington; or, more comprehensively put, the restoration of the natural conditions of each animal was the main thought in Mr. Langley's plan—a plan that, though not yet fully realized, has been more than justified by the results.

#### IV.

In the center of the park is the coon tree. This very tree had undoubtedly been climbed many a time by the wild coons, within a few years, before it was selected to be the center of a little coon kingdom. It is now the abode of over 30 thrifty specimens, which live their lives here much as they once did in the woods, and there is no reason to suppose that they suffer in any way, since all their needs—food, shelter, companionship, and amusement—are cared for. They have indeed all the good things that their wild brethren have, excepting only that there is a limit to their liberty.

Usually they may be seen all day sunning themselves in the high crotches, and the sunnier the day the higher the crotch, so that they are a living barometer. When there is a prospect of continued fine weather the coons climb up as far as they can safely go, and at a distance they look like fruit still hanging on the tree. But in doubtful weather they sit lower and nearer the trunk; there they look more like nests, and give the tree the appearance of a rookery; while, in a storm, all descend and huddle together in the great hollow trunk that lies on the ground below and at all times serves as the bedroom of the colony.

The scientific name of the coon means "washer," and one of his popular names is "wash bear," from the peculiar trick he has of carefully washing all his food. This interestingly Mosaic habit the coons keep up in captivity, no matter how clean the morsel or how doubtful the water may be; and as their tactile paw is busied soaking the next piece of provender, their eyes take in the surroundings as though they were not needed in the supposed purification of the food. These, of course, are habits learned in the woods. The coon feeds along the edges of the creeks and ponds, picking up crawfish, frogs, and other mud-dwellers. Then, having secured them, he is careful to clean them off in their native stream, so as not to eat mud with every course. And this being a matter he can very well leave to his very sensitive fingers, his eyes are judiciously employed in scanning the woods about, either for more game or to guard against being made game of himself by some powerful enemy.

Those who have seen the little ones when they are old enough to be brought to the water by their mother, and there receive their first lessons in frog hunting, describe them as doing everything just as she does, copying her in all things, dabbling their paws in the mud as their watchful eyes rove about scanning the neighboring woods.



THE COON FAMILY.





Another microcosm, and even more picturesque than that for the coons, is the one planned for the mountain sheep, but still delayed for lack of means. Mr. Langley proposes to inclose a tract of several acres of rocky, hilly land, more or less covered with timber, and therein to establish a miniature of the Rocky Mountains, where the bighorn sheep and his neighbors, the calling hare and the mountain marmot, may live together and show us how they used to live at home.

There are many obscure problems of life history and environment that might demonstrate themselves in an inclosure of this sort. To illustrate the complexity of such questions: The presence of the pelicans on Pelican Island, Yellowstone Lake, is declared by authority to be essential to the life of the parasites that infest the trout of the same waters, since at one stage the parasite lives in the bird. This case is of a type that is common. No man can say now whether or not the general failure in other zoos to preserve the mountain sheep in confinement is due to the need for any one element of its native environment, but the way to find out is by restoring the proper surroundings, animate as well as inanimate, as far as possible. Experiments of this sort must increase our knowledge of the laws of life, and in time will solve the problem of successfully maintaining our mountain sheep in captivity.

For the bears also is planned a roomy park with restored environment. Bears are restless, roving animals, much more so than deer, or indeed than most of our large quadrupeds, and they suffer proportionately when shut up. Many carnivorous animals breed in captivity, but bears are among those that do not, not more than two or three cases being on record. This is an evidence of the great pathological disturbance from caging in the ordinary way. The added feature of a geological disturbance in the small bear pen near the south entrance resulted in a little ripple of excitement some years ago. A heavy rain storm during the night washed down from the cliff into the unfinished pen such a pile of rocks and sand that a young grizzly mounting on it was enabled to climb up and escape into the open. He hid himself in the thickest shrubbery of the park and for a day or two eluded recapture, to the consternation of numerous mothers whose children going to school had to pass near the park. Each one, of course, could in imagination see her own particular offspring suffering the fate of the naughty children who scoffed at the baldheaded prophet. But those who saw the grizzly during his brief spell of liberty say that he was so overwhelmed by the novelty of his situation that he was quite the most timorous of all concerned in the affair.

The buffalo was one of the American animals chiefly in view when the idea of the park occurred to Mr. Langley. The present herd is a fine one, but the amount of ground available for them is not sufficient for ideal conditions.

I have heard it said that a little enmity in the life of a caged animal is better than absolute stagnation; but of course the enmity must be within limits. The buffalo herd had so far reverted to the native state that the old bull ruled for several years, much as he would have done on the plains. He was what the keeper called "not a bad boss;" that is, he was not malicious in his tyranny. One of the younger bulls made an attempt to resist him once, and had to be punished. The youngster never forgot or forgave this, and a year or so later, feeling himself growing in strength, he decided to risk it again. He advanced toward the leader, "John L.," and shook his head up and down two or three times, in the style recognized among buffalo as a challenge. The big fellow was surprised, no doubt. He gave a warning shake, but the other would not take warning. Both charged. But, to the old bull's amazement, the young one did not go down. What he lacked in weight he more than made up in agility. Both went at it again, now desperately. After two or three of these terrific shocks the old one realized that he had not now his old-time strength and wind. As they pushed and parried, the young bull managed to get under the other, and with a tremendous heave actually pitched his huge body up into the air and dashed him down the hillside. Three times the old bull was thus thrown before he would yield, and then he sought to save his life by flight. But they were not now on the open plains; the pen was limited, and the victor was of a most ferocious temper. The keepers did what they could, but stout ropes and fences interposed were no better than straws. The old bull's body was at last left on the ground with 63 gashes, and his son reigned in his stead. This is one of the melancholy sides of animal life—the weak to the wall, the aged downed by the young. It has happened millions of times on the plains, but perhaps was never before so exactly rendered for human eyes to see.

A more peaceful and pastoral side of life is to be seen among the waterfowl ponds. At one time the park waters were a favorite resting place of the gulls and ducks that passed over in the migrating season, a few of the ducks remaining to breed. But the encroachment of the city frightened all away, until the establishment of the park resulted in a new arrangement, whereby gulls, swans, ducks, geese, etc., instead of passing over in spring and fall merely, are induced to stay as permanent residents. Food, protection, and cover are provided for them, that they may live their lives before us; and, in order that they may not forget their part of the supposed bargains, a deft, slight operation is performed on the tip of one wing. It leaves no sign of mutilation, but it effectually induces them to remain permanently in the park.

Among the birds of prey many old friends of the woods and plains are to be seen, though not taking to their cage lives as do the more cheerful waterfowl.

The familiar red-tailed buzzard is here, but his eye has ever kept

PLATE VI.

Smithsonian Report, 1901.—Seton.



AMONG THE BUFFALO.





A BUFFALO COW.





BUFFALO CALF A WEEK OLD.







A BUFFALO DUEL IN THE ZOO.



the look of untamed savageness; he has no appearance of being even partly at home in his cage. None of his race has ever been known to accept submissively the prisoner's condition, so that the species does not breed in captivity, nor do his relatives and fellow-captives, the buzzard hawk and the serpent eagle. Doubtless this is simply another case where it is necessary to restore the wild condition in order to know the perfect bird. Some day we may have a cage large enough to give them a chance really to use their wings, and then they may condescend to show us how their forbears built their nests and reared and trained their offspring for the chase.

The fine collection of wolves, still in small quarters, gives a good opportunity of seeing how near they are to dogs in their general habits and appearance.

Zoologists have long discussed the origin of the dog. Some consider it the descendant of a wolf; others, of an extinct species; and some say that the jackal is the wild stock it came from. There are many good arguments against the second theory. To-day it is believed that either the wolf or the jackal was the wild ancestor of the dog. I am convinced that the jackal is the stock parent, though a strain of wolf blood has certainly been infused in some countries.

It long ago struck me that reversion is the best evidence in a discussion of this kind, and my own observations on dogs that have reverted, or gone back, to their ancestral form point very uniformly to one conclusion.

The general color of a wolf is grayish, with a black or dark tail tip, rarely with light-colored spots, or "bees," over its eyes, and with a height at the shoulder of about 26 inches.

The general color of a jackal is yellowish, with more or less white hair in the tip of its tail, and invariably with bees over its eyes. Its height is about 20 inches at the shoulder.

All the largest breeds of dogs show signs of overdevelopment, such as faulty teeth, superfluous toes, frail constitutions, etc. All dogs that have any white about them have at least a few white hairs in the tip of the tail; and when allowed to mongrelize freely—that is, to revert—the dog always becomes a small, yellowish animal, with brown bees over its eyes, a white tail tip, and a height at the shoulder of about twenty inches—that is, it resumes the jackal type.

Another argument, which I have not seen in print, is this: Although the wolf was abundant in Europe during the old stone age, the dog was unknown till it appeared on the scene with the Neoliths, a race that came from the home of the jackal.

My observations on the habits are evidence for the jackal theory. Wolves rarely turn around before lying down; dogs and jackals usually do. Wolves rarely bark, while jackals, as is well known, do frequently bark after the manner of dogs.

While sketching among the jackals in the Jardin des Plantes, Paris,

in 1895, I discovered an interesting bit of evidence on the question. Wolves' eyes are set obliquely, as in figure 2, plate III, and dogs' eyes are set straight, as in figure 1. This, of course, is well known. But of the 9 jackals then in the menagerie 2 had their eyes set wolf-fashion, and the remaining 7 had them set like those of a dog. Of course, the fact that both styles are found in the same animal takes from its weight as proof, and yet great stress has been laid on this different angle of the eyes as an important difference between dog and wolf. What weight, then, this argument has, is for the jackal.

While making these notes among the animals of the Washington Zoo, I used to go at all hours to see them. Late one evening I sat down with some friends by the wolf cages, in the light of a full moon. I said, "Let us see whether they have forgotten the music of the West." I put up my hands to my mouth and howled the hunting song of the pack. The first to respond was a coyote from the plains. He remembered the wild music that used to mean pickings for him. He put up his muzzle and "yap-yapped" and howled. Next an old wolf from Colorado came running out, looked and listened earnestly, and, raising her snout to the proper angle, she took up the wild strain. Then all the others came running out and joined in, each according to his voice, but all singing that wild wolf hunting song, howling and yelling, rolling and swelling, high and low, in the cadence of the hills.

They sang me their song of the West, the West:  
They set all my feelings aglow;  
They stirred up my heart with their artless art,  
And their song of the long ago.

Again and again they raised the cry, and sang in chorus till the whole moonlit wood around was ringing with the grim refrain—until the inhabitants in the near city must have thought all the beasts broken loose. But at length their clamor died away, and the wolves returned, slunk back to their dens, silently, sadly I thought, as though they realized that they could indeed join in the hunting song as of old, but their hunting days were forever done.



GRAY WOLF WATCHING HIS CHANCE.

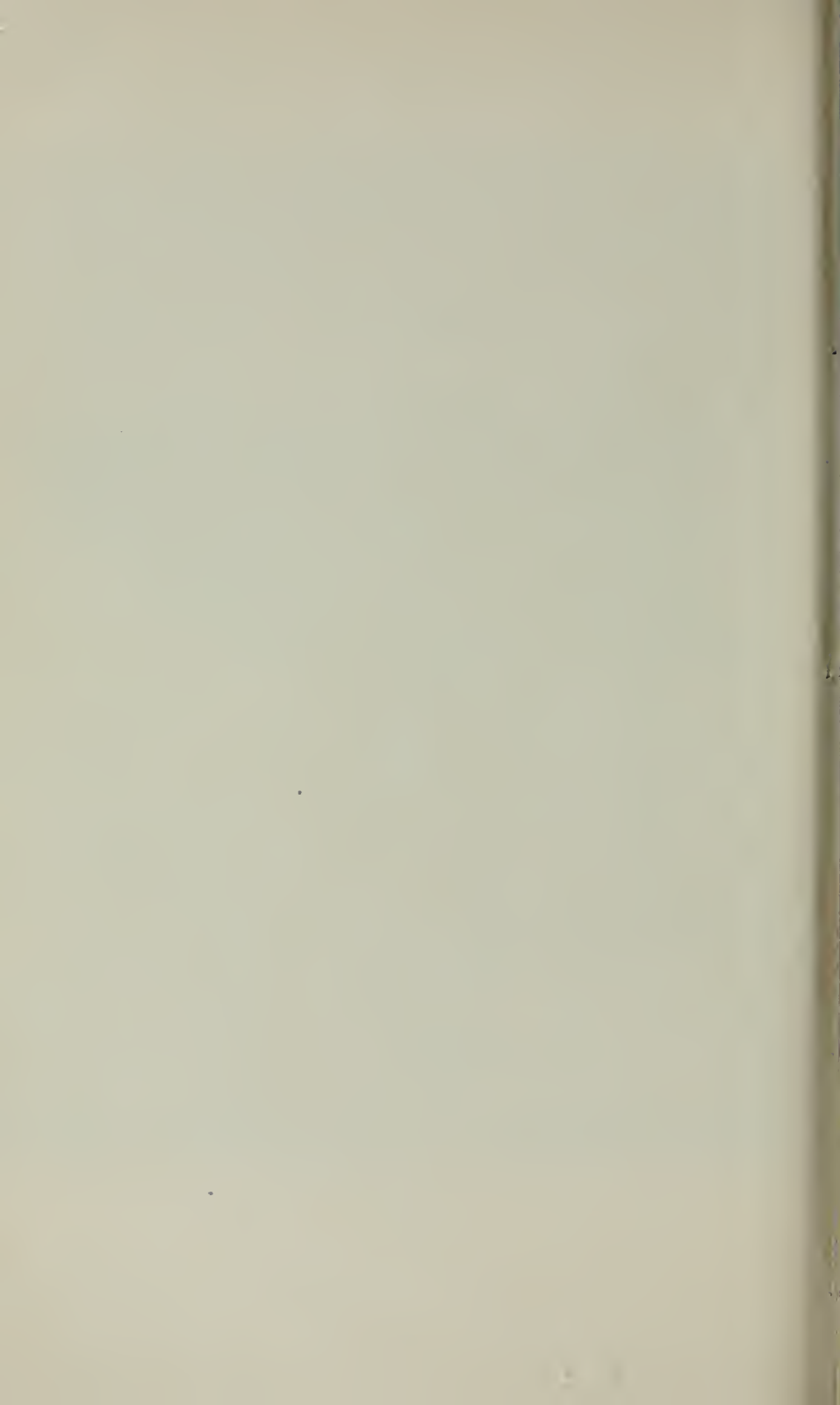



A RUNNING WOLF.







RED-TAILED BUZZARD.



SERPENT EAGLE.

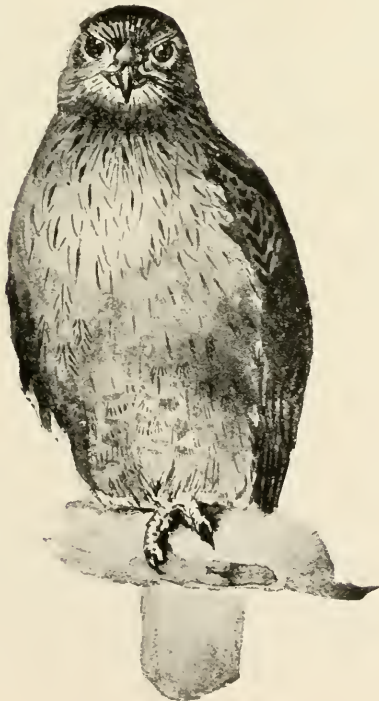

BUZZARD HAWK.





THE WALTZING OSTRICH.



## THE SUBMARINE BOAT: ITS VALUE AS A WEAPON OF NAVAL WARFARE.

---

By GEORGE W. MELVILLE,  
*Rear-Admiral, Engineer in Chief, United States Navy.*

---

The advocates of the submarine boat during the past year have considerably modified their claims as to the value of this type of naval construction as a future weapon of war. The zeal of the new convert is proverbial, but those who have had experience either in the management or construction of this type of craft are making fewer promises, and are quite content with the accomplishment of performances that can in no wise be regarded as of an extraordinary nature.

It is thus along more conservative lines that those who have faith in the ultimate efficiency of the boat are now working. The demand is not now seriously made to build these boats by the score. The more modest request is urged that we should authorize sufficient construction to hold together the skilled workmen that are required to build this type of craft. This is a very fair proposition so long as it is not restricted to building boats of a special firm.

### DEVELOPMENT STILL IN AN EXPERIMENTAL STAGE.

Fortunately for the interests of the Government, there were but few practical naval architects, marine engineers, or distinguished naval officers who were carried off their feet by the exaggerated statements made as to the capabilities of this type of craft. As a result of a conservative policy, we have only eight boats built, building, or authorized. As to whether this number is sufficient for present purposes, the views of Admiral Dewey, written a month ago, probably reflect the general sentiment of the Navy. Upon this matter Admiral Dewey thus wrote to a member of the Committee on Naval Affairs, House of Representatives, May 27, 1902:

“The next two questions which you ask relate to the necessity and advisability of providing now for the construction of additional boats of the Holland type. With regard to this matter, I concur with the Secretary of the Navy in the opinion expressed in his letter of January 9, 1901, to your committee, to the effect that as a number of boats of this type are now under construction, it is wise to await their completion before providing for others.”

## UNITED STATES STRENGTH IN SUBMARINES ONLY EXCEEDED BY FRANCE.

Our strength in submarine boat construction is only exceeded by that of France and England. Without taking into consideration the strength of France and England, the United States possesses or has authorized more submarine boats than all other naval powers combined. Compared with most countries, we are, therefore, in advance in this form of naval construction. Our only regret should be that all of our boats are of a particular type, and that this type should not have yet been proved to have developed beyond the experimental stage. The fact that not one single boat of the Holland type contracted for in August, 1900, and which should have been completed July, 1901, has yet had an official trial, conclusively shows that boats of this design have not yet been developed to a stage that makes them reliable weapons of war.

## CHARACTER OF EXAGGERATED CLAIMS ADVANCED.

There have been some wonderful claims made for the submarine. Only a year ago it was maintained that one of the boats under construction would be able to steam across the Atlantic. Less than a month ago, in an official hearing before the Committee on Naval Affairs, House of Representatives, on submarine boats, an expert of the Holland Company testified that the air-supply storage, which is 69 cubic feet at a pressure of 2,000 pounds, is sufficient for a crew of seven or eight men for three months for submerged work. When questioned upon this point the expert said: "I not only think it, I am quite sure of it." Even a distinguished naval architect is very fond of stating: "The boat performs in a way that can best describe it as a fish of steel with the brains of a man." Such are the character of the exaggerated claims that have been made as to the efficiency and performance of these boats.

It is not surprising, in view of such testimony, that the subject appeals very strongly to the imaginative. The reaction, however, has already commenced. The admiralty officials of the several countries have discovered that the capabilities of these boats have been so greatly magnified, and their weaknesses so adroitly passed over, that there is now a tendency to construe contract requirements very strictly, and to demand that promises will turn into performances.

## ABSURD SECRECY ENVELOPING THE QUESTION OF SUBMARINES.

There has been an absurd and pedantic secrecy enveloping the submarine which has caused the general public to attach great value to the boat as a weapon of war. Comparatively few naval officers have had an opportunity to estimate its powers for offensive and defensive work. A few specialists have written of the tactical value of these

boats, and considerable weight has been given to their opinion by reason of the mystery which has been ascribed to the construction and operation of the craft. Any tactical value that the boats may possess will be dependent upon the speed when running upon the surface or submerged, the ability to maneuver, the power to find the enemy, the facilities for discharging and taking on board a torpedo, and the radius of action when submerged. These factors will be dependent upon the structural arrangement of the boat and the character of the auxiliaries installed, and therefore any mystery surrounding the boat would be very short lived.

#### TIME AND EXPERIENCE MAY DEVELOP AN EFFICIENT CRAFT.

The naval battles of the future will be won by the nation which has made preparation for a conflict, and which has supplied itself with every possible weapon of war. Although an implement may not do all that it was designed to perform, yet it is possible that by development its capabilities may be increased to an extent that was not originally deemed probable. Many experts are doubtful as to the value of ordinary surface torpedo boats, and yet as long as rivals possess them, no nation would think of dispensing with this form of construction. We can anticipate the same experience with the submarine. As few things are impossible, the submarine may be developed in time to a state of efficiency and reliability that will cause a revolution in the composition of fleets. Such a result, however, can only be brought about by encouraging competition. Every individual inventor who has made a distinct advance in improving the efficiency of the submarine should be substantially rewarded. Under no circumstances should the opinion be permitted to prevail that any one design of boat is an accomplished fact, and that no further development is possible.

#### NO NATION CAN RETAIN A MONOPOLY OF PERFECTED DESIGN.

As the several naval powers are seeking new weapons of war, it will not be possible to prevent the use of any appliance that has a military value. Neither conservative officials nor national jealousy could stand in the way of the adoption of any appliance that could be used for offensive and defensive work by military or naval authorities. In the struggle for naval supremacy, the inventive genius of the American, the practical experience of the English, the application of the Russian, the exact science of the French, and the profound thought of the German are being exercised. The desire and passion for military strength is so great upon the part of all powers, that there is no hesitancy, upon the part of any, to copy from the other any plan or process which makes for increased military efficiency or wider field of action.

## SKEPTICISM AS TO THE POLICY OF FRANCE CONCERNING SUBMARINES.

The fact that France alone places great reliance in this particular weapon can be viewed from two standpoints. There are those who will believe that her experts have made a great military discovery, and that she has greatly augmented her naval strength for both offensive and defensive work by building a great number of this small craft.

There are others who will believe that the French Admiralty has made a great mistake in giving encouragement to any form of naval construction that will interfere with the building of battle ships and cruisers. One does not have to read very far back into French history to learn that in 1870 the French military authorities believed that in the possession of the mitrailleuse France had a field weapon which would solve the question as to who would be the conqueror in case she became involved in war with a neighbor.

In the contemplation of her experience with the mitrailleuse France may well ponder whether or not other nations are blind to the merits of the submarine. A cursory reading of the French naval journals shows that even her experts are still at work overcoming inherent difficulties connected with the submarines. Even when the boats are used for surface work there are questions of habitability and navigability that do not seem fully solved.

## DESIGN AND CONSTRUCTION SIMPLE IN CHARACTER.

There is extreme fascination to many people in contemplating the scope and operation of a weapon of war that can be used for either surface or submerged work. The general public neither attempts nor cares to solve the mystery. The whole subject is treated as one of the wonders of the century, and the skeptic is classed with those who ridiculed the work of Watt, Fulton, and Stephenson.

There is no mystery in the submarine boat. The craft of to-day is practically of the same design as that of a century ago. There is increased efficiency and wider range of action, because we now possess materials of construction which are lighter and stronger and which can be better manipulated than the material of a previous century. The auxiliary and motor of to-day can be encompassed in a fraction of the space that was required for one of the same power in the days of Fulton. The machine tool has a capacity and capability far surpassing that of its counterpart of fifty years ago. The advances that have been made in making the submarine boat more efficient have been almost altogether along engineering lines. It is because the capabilities of the engineer are progressively increasing that still further advance will be made in the development of the submarine boat. There are hundreds of scientists investigating the possibilities of perfecting a storage battery that will be more compact and of greater power. There are metallurgists who are conducting extended tests



to discover a metal that will be noncorrosive, nonmagnetic, of lighter weight, and yet of greater strength. It is to be hoped a petroleum motor can be substituted for the gasoline engine for surface work. There are other weaknesses of the submarine which the engineer in part will yet overcome.

Neither the marine engineer nor the naval architect perceives anything mysterious in either the design, equipment, or operation of the boat. The few men who operate these boats can not attach any substantial value to the craft by ascribing some tactical attributes to their use. In general, the boat is a parabolic spindle with a conning tower, the hatch of which can be hermetically sealed. This spindle contains a gasoline engine for surface work, and a storage battery for submerged operations. There are ballast tanks which can be rapidly filled and emptied, and by manipulating the ingress or egress of water into these tanks the buoyancy is destroyed or secured. Such a craft must necessarily have limitations. It has been the effort of inventors to overcome weaknesses rather than revolutionize the design in the effort to extend the field of operation of this possible weapon of war.

#### BOATS OF THE DIVING TYPE HAVE LITTLE LONGITUDINAL STABILITY.

On boats of the diving type but little advance has been made in securing increased stability. Where a boat is designed to dive like a porpoise, it is practically impossible to secure longitudinal stability. When the craft is in condition for diving, the center of gravity must be near the center of buoyancy, otherwise the influence of the horizontal rudders would not affect the boat. With an exceedingly well-skilled and resourceful man at the steering wheel, with a well-trained and efficient crew, and with favorable conditions as to wind and sea, a boat of the diving type can submerge and rise with considerable success and certainty. Where such favorable conditions do not exist, it is extremely improbable that the boat can steer a desired course, or that she will be fully under the control of the operator. A submarine boat of this type will undoubtedly be thrown off her course by the effect of currents, tides, or waves, in case she has not sufficient speed to overcome the strength of strong local eddies. In the absence of a guiding medium, such a boat simply gropes about. In commenting upon this weakness of the submarine boat, Captain Mahan writes:

"I should be interested to see some demonstration that the submarine boat will not find a practically insuperable difficulty in discerning her prey—in seeking it, I should rather say."

#### ENDURANCE OF CREW AN IMPORTANT FACTOR.

It should ever be remembered that the actual limit of the operations of the submarine boat is a limit of endurance of the crew. The skilled artificer in charge of the motor can not escape breathing, at least a small portion, of the products of combustion when the gasoline engine

is in operation, for gasoline is a great sealer, and constant difficulty will be found in keeping the joints tight. It may be maintained that it will be an easy matter to change crews. It will be a rather difficult undertaking, for it requires a man of unusual nerve, skill, endurance, and readiness of resource to operate the machinery of a submarine boat for general work. In boats of the diving type the man at the wheel must have experience, skill, pluck, and judgment, for the craft will do very little porpoise-like work if you have anything but an exceptional steersman. Any interchange of crews will have to take place in the harbor, for the picket boats of the blockading squadron would be on the alert to prevent such a transfer.

On the official surface-endurance trial of the *Holland*, when the conning-tower hatch was open during the entire run, one of the causes assigned for requiring forty-eight hours to make a trip of 148 miles was the delay experienced in giving the crew necessary rest. When the hatches are closed and the storage battery is in use, noxious fumes will collect from gasoline leaks and the exhalations of the crew, as well as by chemical action in the battery cells.

#### CHARACTER OF SUBMERGED TEST OF FULTON.

It is true that a submerged test of the *Fulton* has been made, but one may ask, Was that test made under seagoing conditions? By plugging the gasoline tanks, by preventing chemical action in the cells, and by taking other precautions the crew of a submarine might remain under water a considerable time. In analyzing this performance the following facts are noticeable: The boat was sunk in 16 feet of water, the top of her conning tower being about 6 feet below the surface. The boat remained quietly at rest. Surely the same work could be done in a diving bell. In fact much more severe conditions are imposed in caisson work in the building of tunnels under river beds.

When submerged the *Fulton* has a displacement of 120 tons. In this condition she has about 2,000 cubic feet of space which contains only pure air. In addition she has 12 welded steel storage tanks with a total capacity of 69 cubic feet, and the air is pumped into these tanks up to a pressure of 2,000 pounds. The air tanks under this pressure actually hold about 130 tank volumes of air at atmospheric pressure. In other words, there are 9,000 cubic feet of reserve air. With at least 2,000 feet in the boat there is a total of 11,000 cubic feet to draw upon. The eight men that constituted the crew of the boat had, therefore, each about 1,400 cubic feet to draw upon. This would mean a room about 10 feet high and 12 feet square for one to live in for a period of fifteen hours. This, of course, is not any too much space, but it is plenty for sanitary purposes.

It should be taken into account that the gas exhalation is much

heavier than fresh air, since it is carbonic acid, and not a mechanical mixture of nitrogen and oxygen. By simply keeping in the upper portion of the vessel the crew would almost have comparatively fresh air nearly the entire time. Quite a different tale would have been told if the *Fulton* had been made to get under way. She would then have had to use her electric motors, and a drain would have been made upon her storage batteries. From this cause noxious vapors would have been generated and the various compartments would have been uninhabitable after a fraction of the period that would have been required to make the boat unendurable from the human exhalation.

It is on record that one individual in a New England town several months ago actually entered a metallic burial casket and was sealed up for a period of one hour. He simply demanded that the glass plate over the head piece be not covered and that the individuals conducting the test should look through the head plate at intervals, so that he could smile at them. It was rather a ghastly test, but it was a successful one, although the individual undergoing the operation lost 5 pounds in the undertaking. In this test the man did not probably have 2 cubic feet of air to draw upon. To appreciate exactly what was undergone by those who went down in the *Fulton*, the crew had simply to enter a hermetically sealed room of the dimensions recorded. It did require physical courage, however, for eight men to remain in a submarine boat under those circumstances, since derangements were possible which might have prevented the boat rising.

#### COMPASS UNRELIABLE IN BOATS OF DIVING TYPE.

For the past ten years the advocates of the submarine have been telling at intervals of a discovery whereby the submarine boat can be navigated with precision when under way. One of the ablest compass experts in the Navy has given special attention to this matter. In the investigation of this subject he found that a reputable adjuster of compasses from New York, who corrected the compass of this submarine boat, furnished the Holland Company with nine different deviation tables, to be used as a disposition of the disturbing torpedoes necessitated. It is his opinion that, in general, the compass on the submarine boat must be regarded as more or less unreliable. Placed near to or within an iron or steel mass, it is subjected not only to large disturbing influences, but also to a serious decrease of directive force. Any change in magnetic conditions within the vessel itself, as well as accidental extraneous influences, will attack the weakened compass with a force inversely proportional to the directive force. The inclination of the boats of the diving type is a great disturber of the compass, and must be very carefully corrected. This expert maintains that the magnetic compass in a submarine boat will be so unreliable that the craft will frequently be compelled to rise to the

surface to recorrect the course steered, as well as to ascertain whether the object to be attacked has not changed her position. In boats of the *Holland* type, the plan of furnishing a large number of deviation tables, to cover all possible conditions within the craft, will certainly lead to poor results in the excitement of action, even if the enemy is unwise enough to maintain a fixed station.

It will not be the particular province of the battle ship to seek destruction. On the contrary, she will take means to avoid such a catastrophe. The submarine will then be compelled to seek her. It will seldom be the case that the blockading battle ship is not kept under way, and as her speed will be greater than the submerged boat, the opportunity will be certainly remote when the submarine can discharge her torpedo.

#### TIME REQUIRED TO PREPARE THE HOLLAND BOAT FOR DIVING.

One would presume from a cursory reading of the literature upon submarines that boats of the diving type only require a few seconds to go from the surface to the submerged condition. It will require minutes rather than seconds to perform the evolution, and during this period the submarine boat will be exposed to the fire of the magazine and quick-firing guns of the blockading squadron. When the submarine boat is running on the surface and using her gasoline engines, it will require some minutes to unship ventilators, fill the compensating tanks, and exhaust the gasoline fumes from the hull compartment. In fact, she will have to run in the awash condition for some time to fully prepare her for submergence.

The French Admiralty ought to have some pretty positive information upon this question. In fact, one of the most serious objections urged to the submergible type of submarines has been the length of time necessary to effect submergence. In the boats of the *Narval* class it took half an hour to perform the operation. Only two years ago the *Narval* was considered the most efficient of all the French submarines. In the *Sirene* class the time was reduced to a little over ten minutes. The *Sirene* was authorized June 20, 1899. She has been in commission about eight months. It is hoped that the time of submergence will be reduced to five minutes in the boats that have just been laid down in France. The knowledge of the experts of the French Admiralty must be exceedingly limited if her experts are content to design a boat that will require five minutes for submergence, while the *Holland* only requires five seconds (?) to perform the same evolution.

As a matter of fact, the French experts measure the time from running on the surface to the time of disappearance. Some of our experts are content to measure the period from the time when all preparations have been finished to the time when she goes under the water.

It may only require a second to discharge a submarine mine. It

may require hours to lay the mine in a harbor where strong tides are running. It is just as logical to maintain that you can fire a 12-inch gun in a fraction of a second, as it is to contend that a submarine boat can dive from a surface run to a submerged run condition in a few seconds.

UNCERTAINTY OF ACTION OF WHITEHEAD TORPEDO WHEN LAUNCHED FROM A SUBMARINE BOAT.

The torpedo which is carried by the submarine boat has yet to show for submarine work the practical utility for its existence. Next to the arrangement of the mechanism of a watch or a clock, there is probably no contrivance where more appliances are installed in a limited space than in a Whitehead torpedo. The workmanship must be of the finest character and the adjustments of a delicate nature, in order to make the torpedo take the desired course. It will be admitted that at the torpedo station, or at the establishment where they are manufactured, some very reliable work is secured from them, but when they are placed on board ship and receive other than ordinary care, they perform all manner of strange evolutions when launched from a tube, and often go astray. When there is actual need to fire these torpedoes there is not at command the skillful mechanics and adjusters that are intrusted with the experimental work at the torpedo station. During the fourteen years that I have been at the Navy Department I have personally asked hundreds of observing officers if they knew of one case in actual warfare where a torpedo, launched from a ship at a moving target, has been effective. Official records have been examined, but no evidence can be adduced that a single torpedo has sunk a ship that was in motion.

There have been cases where torpedo boats have sunk practically abandoned vessels. There are instances where ships at anchor have neglected to keep a lookout, and have in this way been struck by a torpedo. It is also a matter of record that in some instances torpedoes have successfully drifted down on ships at anchor and crippled or destroyed them. The unreliability of the torpedo in actual practice is a factor of importance in determining the worth of the submarine boat. Due to the fact that improper adjustments have been made in the mechanism of Whitehead torpedoes, many either go under the target, sink to the bottom, or take a different course from that intended. The friends of the submarine would have people believe that the action of a torpedo is as certain as that of a rifle shot, and that you have simply to launch the weapon from the tube within striking distance to secure the effect desired.

DANGER OF USING GASOLINE.

The best propelling agent now available for surface work in a submarine is undoubtedly gasoline, but it is to be hoped that petroleum

motors will be so perfected that they can be substituted for this special work. Statistics show that the loss of life due to gasoline explosions is appalling. Careful investigation proves that these explosions can be ascribed to spontaneous combustion or to molecular changes due to special conditions. It is true that thousands of gasoline launches are in use, but these launches are nearly all open boats, and the gasoline tanks are often pipes which are placed on the outside of the boat something similar to a keel condenser.

In the submarine boat you have the storage battery in close proximity to the gasoline reservoirs. The switches, fuses, and electrical contacts necessary for the operation of the incandescent lights and various motors must of necessity be open to the air. Sparks form when these electrical appliances are started or stopped, and a single flash may be all that may be necessary to explode gasoline fumes.

GASOLINE TANKS SHOULD NOT BE KEPT WITHIN THE HULL OF  
SUBMARINE.

Gasoline is a great searcher, and as long as the tanks of gasoline are kept within the boat itself it will be practically impossible to prevent some leakage. In starting the gasoline engine some of the gas is likely to escape through stuffing boxes, check valves, and joints. It would not be necessary to have much free gasoline in the boat to cause an explosion. In the case of oil-carrying ships, it is when the tanks are well nigh or quite empty that explosions are most likely. The record of accidents to oil-carrying ships proves that explosions nearly always occur when the vessel is in port, and that the danger is greatest when the tanks have the least oil in them. It is not the amount of gasoline carried that constitutes the danger. It is the leakage which is the greatest menace, for when the liquid volatilizes and combines in certain proportions with the air, and is followed by a spark, it is quite certain that an explosion will result. In fact this is the action of a gasoline engine.

Where the gasoline is kept within the hull the reservoirs are often built-up tanks, i. e., tanks which are built between the frames. It will be extremely difficult to make these tanks perfectly tight, on account of the difficulty of properly calking the seams. It is well known that gasoline is ordinarily kept in cylindrical reservoirs where there are but few seams to leak.

The danger from gasoline is not imaginary. The crew of the *Holland* were almost asphyxiated from this cause. Constant trouble from inhaling gasoline is being experienced with the French boats. The Engineer, of London, in its issue of June 20, 1902, makes reference to an accident of this character:

“Life in French submarines is not apparently ‘all beer and skittles.’ The submarine *Silure* recently went out on trial, and the crew began

to get insensible. 'Whereupon,' says the French paper from which we quote, 'several of our brave sailors began to ask, Is all well?' The answer apparently was in the negative, so the rest went homeward, with three men well-nigh suffocated."

#### GASOLINE TANKS COMPARATIVELY SAFE WHEN STORED IN SUPER-STRUCTURE.

It has been maintained that as the gasoline tanks are stored in the superstructure the boats are likely to be destroyed by a fragment of shell hitting the tanks. Such would not be the case. Liquid gasoline is difficult to explode. The shell might rupture the tank and permit the liquid to run into the sea. It might even be set on fire. You would then simply use gasoline from another tank or else turn on electric power and steam out of the region of the burning oil.

As an illustration of how difficult it is to explode liquid gasoline, the burning of a valuable gasomobile at Sewickley, Pa., will afford some pretty positive information. The machine not working properly, the chauffeur and the owner dismounted to ascertain the cause. They found the gasoline tank leaking, and while they were examining the appliance the liquid suddenly ignited. A bystander pulled a fire-alarm box and two fire companies were quickly on the scene. Both chemical extinguishers and water were played on the flames, but they were not extinguished until the machine was ruined. There was no explosion, simply a slow burning of the liquid fuel.

#### THE ANTIDOTE TO THE SUBMARINE.

For the past three years considerable thought has been given to the subject as to the best manner of disabling the submarine. The British Admiralty regard with considerable favor a device in the form of a spar torpedo, electrically dischargeable, easily dropped, and composed of powerful explosives. Some experiments have already been made, and while the principle embodies no certainty, there are experts who believe that its action is as reliable as that of a Whitehead torpedo, for the torpedo is more than likely to fail in its purpose when discharged from a boat that is somewhat blind, and from a craft whose speed is so slow that a strong eddy would change its direction.

There are other experts who believe that fast-running boats will be able to run the submarines down. As the submarines are slow in speed, and are not easily maneuvered, the picket boats or fast tugs would find the submarine in the same way that you kill a whale. The whale being slow in action, and being compelled to rise to the surface at intervals, can not maneuver as quickly as a skillfully worked boat, and is thus caught unawares. Thus it might be with the submarine—being slow in action, and deficient in maneuvering qualities, the picket boat would have an opportunity to run over them before the subma-

rine could disappear or discharge its torpedo with effect. Under such circumstances the presence of a tug would produce considerable moral effect upon the submarine.

The submarine can also expect that the rapid-fire and machine guns of the blockading fleet will be kept in readiness to welcome them, and it is quite certain that no commanding officer would be sparing of ammunition when on the lookout for one of these boats.

There are many who believe that a submarine boat of the diving type will prove to be more dangerous to its own crew than to the crew of the vessel attacked, and, like the flying machine, it will have very little endurance.

#### ATTITUDE OF NAVAL POWERS UPON THIS QUESTION.

Probably the best way to show the progress that has been made in the development of the submarine boat during the past few years will be to show the extent of construction by the several naval powers and their attitude in regard to encouraging inventors.

#### EXTENT OF SUBMARINE CONSTRUCTION IN FRANCE.

France continues to lead all naval powers in the number of boats built and building. Her experts attach most value to the general worth and usefulness of the craft. At the end of the year 1901 France possessed fourteen submarine boats ready for experimental service. The following eight boats were stationed at Cherbourg: *Narval*, *Morse*, *Français*, *Algerien*, *Sirene*, *Triton*, *Silure*, and *Espadon*. Four boats were used for the defense of Rochefort—*Farfadet*, *Korrigan*, *Gnome*, and *Lutin*. Two other boats, the *Gustave Zede* and *Gymnote*, were stationed at Toulon.

These fourteen boats may be grouped thus:

*Submarines*.—Which are propelled by electrical power. It is not intended that these boats shall have a great steaming radius. Their sphere of action is to defend seaports, or to be carried or towed to the projected scene of operation. Boats of this type are the *Français* and *Algerien*, of 146 tons; also the *Farfadet*, *Korrigan*, *Gnome*, and *Lutin*, of 185 tons.

*Submergibles*.—Boats which use an electric motor for moving under the water, but which use steam, gasoline, petroleum, or some other power for traveling on the surface. The French experts are at variance as to which types are the best. The preponderance of opinion in France, however, is in favor of the submergible, since the tendency is to develop the boat for distant work. The *Morse*, *Narval*, *Espadon*, *Silure*, *Sirene*, and *Triton* are examples of the submergibles.

During the year 1901, twenty-three submarine boats of 68 tons each were authorized. There were also several boats in process of building. According to the naval programme voted by the legislative chambers



of France in the year 1900, there were to be built between that year and the close of 1905, forty-four submarine vessels. Since that time additional construction has been authorized which would give a total of sixty-eight submarine vessels to be completed before 1906.

FRANCE ENCOURAGES COMPETITION IN THIS FORM OF CONSTRUCTION.

It is strikingly significant that in seeking authority for the further construction of these boats the minister of marine invariably tells of the hope that is reposed in some new form of development. In that country, therefore, where the submarine is looked upon with the most favor no type has yet been regarded as an approved one, but there is an inclination to encourage all inventors to submit original plans. In furtherance of the policy of seeking to develop the submarine craft, the French Admiralty gives special encouragement and holds out substantial inducements to inventors to work along new lines. By keeping the field of competition open the friends of every type of submarine construction are compelled to keep abreast of the times. The Admiralty is thus prevented from being saddled exclusively with the design that is less efficient than that possessed by a rival nation. It may not be amiss to state that France does not possess a single boat of the Holland design.

FRANCE WILL POSSESS TEN DIFFERENT DESIGNS BEFORE 1906.

The French Admiralty already announce that of the thirteen submarines that are to be commenced this year her experts will experiment with three boats, each of a new and special design. France already possesses seven different types of those built and building. This is quite substantial evidence that she does not think that the problem is solved. If the Admiralty of that country is to be judged by its acts, then France more than any other naval power believes that submarine-boat construction is in an experimental stage, otherwise an approved type would have been selected ere this. It is strikingly significant that of the ten different designs in her possession she has not yet built a boat of the Holland design. As both England and Norway have been supplied with boats of the Holland design, and as both Russia and Japan have been urged to purchase a boat of this construction, it is fair to presume that France could have secured a Holland boat if her experts deemed the type of much value.

ENGLAND HAS NINE BOATS—BUILT AND BUILDING.

Great Britain has five submarine boats in process of construction. These boats were contracted for in the fall of 1900, although the British Admiralty did not let the fact be known until the spring of 1901. The English boats are of the Holland type, and are practically counterparts of those being built for the United States Navy. It has

been twenty-one months since Vickers' Sons & Maxim were authorized to construct these boats; and the fact that such a firm has failed to deliver the boats on time conclusively shows that unexpected difficulties have been experienced. It has only been within a month that the first of these boats has been accepted, and an expert from the United States maneuvered her during the official trials.

It has been officially reported that the second of the submarine flotilla under construction in the yard of Messrs. Vickers' Sons & Maxim will be different in minor respects from the first boat. The fact that alterations have been made in the construction of submarine boat No. 2, taken in connection with the fact that some of the boats will be a year late in delivery, ought to afford pretty conclusive evidence that the English boats are not beyond the experimental stage.

The British naval estimates for the year 1902-3 provide for four additional submarine boats. The engineering journals of Great Britain state that the new boats will be an improvement upon those authorized in 1900, since Mr. Maxim will make some important changes that will improve their efficiency. The British Admiralty, therefore, does not rest content with having the new construction of the same character as the old. England demands progressive improvement, and we should not rest content with those that have not yet proved their efficiency.

#### GERMANY GIVES NO ENCOURAGEMENT TO THIS FORM OF NAVAL CONSTRUCTION.

The German Admiralty is experimenting with a launch of small tonnage. The naval periodicals of that Empire, in reflecting the opinion of the officers of the naval service, show that Germany regards submarine development as even in an early experimental stage. In discussing the submarine question with one of the staff of Prince Henry in New York, this official informed me that the Americans had done very well in going slowly in building such boats. He further remarked that the German Admiralty had done better, for they had refused to build any.

#### RUSSIA EXPERIMENTING WITH A SMALL BOAT OF TWENTY TONS.

The Russian Government is experimenting with a small boat of about 20 tons, which can be carried on the deck of a battle ship. The length of the craft is 50 feet, while its diameter is only 4 feet. The boat is composed of nine sections joined together by bolts, thus permitting the craft to be taken apart and stowed in the hold of a ship. It is said of this boat that when it is inclined 90 degrees it rights itself immediately, and this claim is characteristic of many others that have been set up in behalf of the submarine. It is reported that a boat something like this type, and of the diving design, sunk by the bow and stood on end. If it were not for the fact that she sank in quite



**NEW UNITED STATES SUBMARINE TORPEDO BOAT. METHOD OF ATTACK.**

Reprinted, by permission, from *Scientific American*, December 28, 1901.



shallow water, and that an accompanying tug got hold of her stern and pulled her nose out of the mud, the boat would have been lost.

## NORWAY PROPOSES TO BUILD ONE.

The Norwegian Government proposes to build one boat of the Holland type. This matter was referred to a board of naval experts. A minority of the board insisted that the present development of the craft did not warrant its introduction into the naval service. The technical journals of Europe state a majority of the board based their conclusion upon the fact that the United States Government had settled upon an approved type, and that Norway should experiment with this design.

## SUBMARINE CONSTRUCTION IN THE UNITED STATES.

The United States has one submarine boat in commission. This boat was built four years ago. Seven other boats are in process of construction.

The names, dates of contract, and contract time of completion of these eight vessels are as follows:

No.	Name.	Date of contract.	Contract time.	Should have been completed.
			<i>Months.</i>	
2	Holland			In commission.
3	Adder	Aug. 25, 1900	8	April, 1901.
4	Grampus	do	8	Do.
5	Moccasin	do	9	May, 1901.
6	Pike	do	9	Do.
7	Porpoise	do	10	June, 1901.
8	Shark	do	11	July, 1901.
1	Plunger	Nov. 19, 1900	11	August, 1901.

DELAY IN THE CONSTRUCTION OF HOLLAND BOATS EVIDENCE OF FACT THAT BOATS OF THIS TYPE ARE NOT BEYOND THE EXPERIMENTAL STAGE.

It is pertinent to ask what has been the cause of this delay. If the boats are beyond the experimental stage, then rapid construction would have resulted very advantageously to the Holland Company. In fact if the boats had been completed, and had satisfactorily met official requirements, Congress would probably have authorized a considerable number. It was this delay in delivering boats that caused many Senators and Representatives to be convinced that the craft are still in an experimental stage.

Before completing these seven boats for the Government, the Holland Company have on their own account constructed the *Fulton*. It was this trial horse, the *Fulton*, which sunk in Peconic Bay early in the winter, and which came to grief several months later at the Delaware Breakwater. Since the British naval authorities, as well as our own naval experts, are looking forward to the results of the official trials of the boats contracted for about two years ago, it seems strange that

work should have been pushed upon an experimental or trial boat if the type had already been developed to a satisfactory stage. It would rather appear as if the Holland Company had encountered unexpected obstacles, and that an experimental boat was necessary in which tests could be conducted independent of naval inspectors.

PROGRESSIVE ADVANCE CAN ONLY BE SECURED BY ENCOURAGING  
COMPETITION.

In the construction of surface torpedo boats the Navy Department invites and encourages the several shipbuilders to submit designs. In advertising for bids for battle ships the Department permits bidders to submit plans of their own. Experience shows that by inciting a rivalry between designers of every kind of naval craft, the Government is a great beneficiary. Any policy which would settle upon an approved type of battle ship, cruiser, ram, surface torpedo boat, or submarine, without taking into consideration the fact that progressive development might be expected, would soon give us a navy whose ships were inferior to those possessed by other powers. Such a policy would develop rather than delay the construction of submarines. In maintaining a progressive advance there would be no reaction of sentiment. There should be just as much encouragement to individuals to develop the submarine as to develop the surface torpedo boat.

SUBSTANTIAL AWARD AWAITS WINNER OF COMPETITIVE TEST.

During the next six months the United States will secure some very positive information as to the practical value of these boats. The seven boats now under construction by the Holland Company ought to have had their official trials. If these boats are able to fulfill contract requirements, then it will be possible for the Department to commission them without delay, and make extended experiments so that not only the efficiency but the endurance of the craft can be determined. Before the last of these Holland boats is turned over to the Government, it is highly probable that the Department officials will have an opportunity of passing judgment upon the efficiency and sufficiency of the Lake submarine boat, now building at Bridgeport, Conn. A contest between these boats should be welcomed by the owners of both craft. It is certain if either boat shows a marked superiority over the other for naval purposes, the fact will be heralded throughout the world, and the successful boat will probably be regarded by many naval officers as the highest type of submarine construction extant. As it is quite certain that both the Lake and Holland people have a pretty accurate knowledge of the capabilities of the rival company's craft, the boat that is the superior will force a contest. Since it is to the interest of the Navy Department to bring about competition between these boats, it can be expected that the Department will not permit either company to avoid a competitive test.

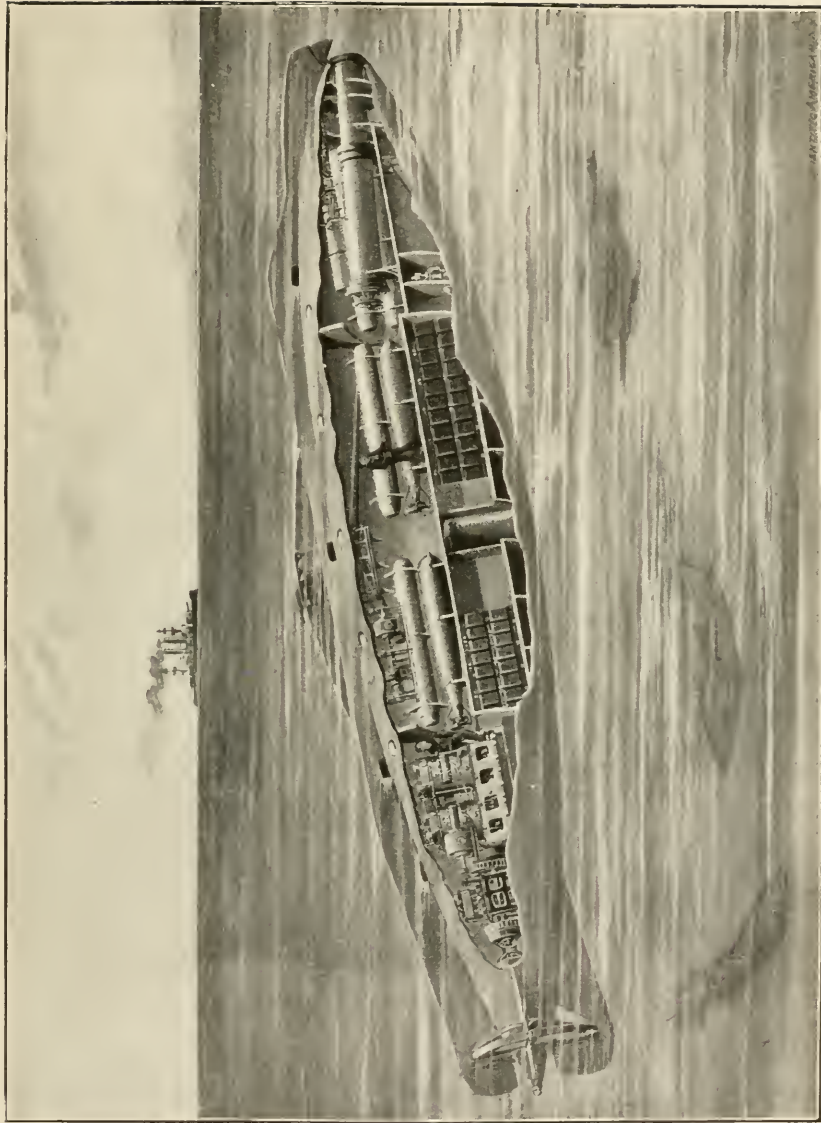

NEW UNITED STATES SUBMARINE TORPEDO BOAT

Length, 63 feet 4 inches; diameter, 11 feet 9 inches; displacement, 120 tons; speed at surface, 8 knots; speed submerged, 7 knots. Reprinted, by permission, from *Scientific American*, December 28, 1901.





The test should be a very complete one. Each company might prescribe conditions for the other to meet. The Navy Department should finally demand requirements that would show whether or not the boat was a useful weapon of war.

#### COMPETITION WOULD ADVANCE RATHER THAN DELAY CONSTRUCTION.

The policy of competition would not make for delay in submarine-boat construction. It would advance the number and efficiency of the craft that we shall possess within the next five years. It will prevent the Navy being exclusively saddled with the design of an inferior type. It will stimulate invention along this line. It will not only prove to the officers of the service, but to individual inventors, that the Navy is not wedded to the belief that technical skill in this line is possessed by few persons. It will compel those securing one contract to keep abreast of the times by making progressive improvements. If you have such competition, you will absolutely discover the character and efficiency of this type of naval construction, and for this reason, if no other, such a policy should be pursued.

Such a policy should be pursued because it is founded upon patriotism and common sense. It may interfere with the purse and prestige of individuals, but such individuals can afford to sacrifice something to increase the efficiency of the Navy, particularly if for a time they have had an opportunity to fatten themselves at the public crib.

The builders of these boats may be very sincere as to the efficiency of their respective types, but of necessity such people must give *ex parte* testimony. The Department should, therefore, be sustained in its contention that performances and not promises should be the factors in determining the advisability of extensively entering into this form of construction.

#### SPECIAL CONSIDERATION SHOWN THE HOLLAND COMPANY.

The Holland Company has been specially favored. The first boat that this company attempted to build was the *Plunger*. This construction was a Government contract. The Navy Department expended about \$90,000 in partial payment before it was evident to the contractors that the boat could not meet official requirements. The company advanced but comparatively little money in taking that contract. Then the *Holland* was built by the company with its own funds. This was an enterprising performance; but it must be remembered that the company was \$90,000 in debt to the Government, and therefore further risks were taken to protect the interests and sustain the prestige of the company. Afterwards six additional boats were authorized by Congress at a cost of \$170,000 each, the same price that was paid for the *Holland*. The Chief Constructor of the Navy has testified that a proper cost of building these boats exclusive of the use of the patents (to which he attaches very little value) will be about \$90,000.

Although the last six boats contracted for are nearly a year late in delivery, friends of the Holland Company made the modest request of the Congress that the Secretary of the Navy be *required* to contract with the Company for thirty of its most improved types of submarine boats. A still more modest request was presented that no contract shall be made with the said company for thirty boats until *one* of the Holland boats now being built for the Navy Department shall have been accepted by the Secretary of the Navy.

The Department certainly expects that all the six boats under construction will be compelled to make contract requirements. In case of failure the contractors have recourse for relief by officially appealing to the Department. It certainly would be a remarkable precedent to establish to contract for more boats of this type after only *one* of the six under construction performed in a satisfactory manner.

THE HOLLAND AND LAKE COMPANIES CLAIM TO BE DESIROUS OF  
ENTERING THEIR BOATS INTO COMPETITION.

The Holland boats now nearing completion will have to contend for superiority during the coming year with a boat of the Lake design. These rival boats are of quite different type. The issue at stake is of moment to both companies and to the naval service. In an official hearing on submarine boats before the Senate Committee on Naval Affairs, a representative of the Lake Company declared:

“As has been said, we are merely on the verge of submarine knowledge. We do not know much about it yet, and much will be a matter of experiment; but of the two boats we are very confident that the Lake boat, all around, is a superior boat to the Holland; and if it is not, the gentlemen who are back of it, and who have confidence in it, are willing that the \$250,000 that they have invested shall go on the scrap heap. They have confidence to believe that their boat has merit, and all they ask is that it shall be submitted to a test.”

At the same hearing on submarine boats a representative of the Holland Company spoke thus in regard to the outcome of a possible test:

“We do not object to competition in the slightest degree. If Mr. Lake has a better boat than ours, if he will conform to all the requirements that have been required of us, let him come in; and if he beats us, we will simply go out of business.”

CONSTRUCTIVE FEATURES OF THE LAKE AND HOLLAND BOATS.

As the Lake design is the latest Richmond in the field of submarine-boat construction, although its inventor has given twenty years of study to the question, it may be pertinent to show in a comparative and comprehensive manner the constructive features of the rival types.

*Lake boat.*

Length over all, 65 feet.  
 Breadth of beam, 11 feet.  
 Displacement afloat, 115 tons.  
 Surface buoyancy, 55 tons.  
 Engine horsepower 250, applied direct to shaft.

Battery capacity, 75 horsepower for four hours.

Twin screw.

Hull sufficient strength to submerge 150 feet.

Armament, 3 Whitehead torpedo firing tubes.

Means of submerging, 3. Admitting water ballast, submerging with the use of hydroplanes, and hauling down to the bottom or to any desired depth by anchor weights.

Means of coming to the surface, 4. Discharging water ballast by either compressed air, power or hand pumps; by the hydroplanes, when under way; by lowering the anchor weights and by releasing the drop keel.

Fuel-carrying capacity, 1,400 gallons.

Speed (estimated), 10 to 11 knots.

Submerged speed (estimated), 7 knots.

Means of traveling on the bottom.

Submerges on a level keel.

Means to enable divers to leave and enter the vessel while submerged.

Automatic and positive maintenance of trim.

Means to measure distance traveled when submerged.

Invisibility in a semisubmerged condition.

Capability of steering long and correct courses.

Automatically controlling depth of submerging.

Means for cutting cables and for mining and countermining purposes.

A water-tight superstructure affording deck space and sufficient buoyancy to make her seaworthy and also afford space for storage of fuel, air tanks, etc.

Automatic drop keel and other automatic features to prevent submerging below a safe depth.

*Holland boats.*

Length over all, 63 feet 4 inches.  
 Breadth of beam, 11 feet 6 inches.  
 Displacement afloat, 105 tons.  
 Surface buoyancy, 15 tons.  
 Engine horsepower 160, less a considerable loss due to driving indirectly through gearing.

Battery capacity, 70 horsepower for four hours.

Single screw.

Strength of hull approximately the same.

Armament, 1 Whitehead firing tube.

Means of submerging, 2. Admitting water ballast and driving with horizontal rudders.

Means of coming to the surface, 2. Discharging water ballast and use of horizontal rudders when under way.

Fuel-carrying capacity, 850 gallons.

Speed (estimated), 8 knots.

Submerged speed (estimated), 7 knots.

Dives by the bow at varying angles.

*Lake boat—Continued.*

Gasoline fuel carried in superstructure where escaping gas or leakage would not injure crew.

Ample officers' and crews' quarters with cooking and sleeping facilities.

Provision for escape of crew in case of partial disablement of vessel while submerged.

*Holland boats—Continued.*

Fuel, gasoline, carried in tanks in the living quarters of the boat.

NAVAL EXPERTS DIFFER AS TO THE RELATIVE MERITS OF THE LAKE AND HOLLAND BOATS FOR NAVAL PURPOSES.

The Lake boat has also to turn promises into performances. A representative of the Bureau of Steam Engineering, however, who was specially directed to visit Bridgeport, Connecticut, upon repeated occasions, to report upon the Lake boat, and has given special study of the subject, thus officially testifies as to her probable performance:

“In my opinion the Lake boat will be shown before the end of the year to be a far superior craft for naval purposes than the Holland. Her superiority will not only rest in special contrivances that are fitted to the boat, but in the manner in which the propelling and other appliances have been installed.”

In opposition to this testimony is the evidence of the naval constructor who supervised the building of the Holland boats. This officer stated that in his opinion “the Holland boat is far superior for military purposes.” He also said:

“The Holland boat is designed as a submarine torpedo boat. The Lake boat, if we allow the inventor all he claims, everything he claims to-day, becomes in effect a dirigible self-supporting diving vessel, which would be useless for a torpedo boat compared with the Holland type; and the use of a diving boat—that is, for countermining—is of very small military value compared with the successful use of the torpedo boat.”

Further construction of submarines should be delayed until a competitive test of the Lake and Holland boats can be made. In view of the conflict of opinion upon the part of counsel of the respective submarine boat companies, and of expert testimony upon the part of naval officers, the Department is justified in withholding all contracts until it is definitely determined whether the Lake boat should be consigned to the scrap heap, or whether the Holland company should go out of business. In the fight to a finish between these companies the Department will be the beneficiary. It is manifestly to the interest of the Department to always encourage competition, for the new competitor can only win by giving the Navy something better than it has possessed heretofore.

## SPIRITED COMPETITION IN SUBMARINE-BOAT CONSTRUCTION EXTREMELY BENEFICIAL.

The advent of the Lake company into the field of submarine-boat construction has been of incalculable advantage to the interest of the Government. The strong presentation of the merits of this boat has materially assisted in preventing the naval service from being saddled with dozens of boats of a type whose efficiency and utility has yet to be demonstrated to the satisfaction of the Board of Construction of the Navy Department, as well as to the Congress.

The problem of a submarine may not only involve a change in naval construction, but a revolution in naval tactics. That nation will fall behind in relative naval strength of every description which refuses to encourage competition among designers, and which is wedded to the belief that in this mechanical age the solution of any technical problem can only be solved by a few persons.

## THE POLICY OF EXPERIMENTATION A WISE ONE.

Before the Congress again assembles the Navy of the United States should have some definite knowledge as to the capabilities and possibilities of submarine boats. The boats now under construction should be commissioned immediately after they have met contract requirements. Then they should be subjected to surface and submerged runs which will not only show their endurance in these respects, but also the limit of endurance of the working crews. It can be expected that the several young officers placed in charge of the boats will be intent upon making their individual commands the most efficient. By thus creating a spirited rivalry between these young commanders the practical advantage and disadvantage of the craft will be ascertained.

Our policy as regards further construction should therefore be in the direction of finding out the actual military value of the boats that we have contracted for. We should also determine the relative worth of these boats as compared with craft of different designs.

Time is not an essential element in this matter, for by offering a premium for rapid speed construction it will be possible to induce many shipbuilders to construct them within six months. If the inducement is made sufficiently attractive, there are shipbuilders who will guarantee to do the work in four months.

The policy of determining the substantial worth of the boats now under construction before authorizing more of this special type has been urged by the Board of Construction of the Navy. This Board consists of the chiefs of the Bureaus of Ordnance, Steam Engineering, Construction and Equipment, also the Chief Intelligence Officer of the Navy. Such a board should have opportunities for securing reliable information upon the subject. The General Board of the Navy, pre-

sided over by Admiral Dewey, also believes in the policy of finding out the possibilities of the boats that are nearing completion. The Chief of the Bureau of Navigation, the President of the War College, and several of the gallant captains who fought at Manila and Santiago are members of this Board, and surely such men have the best interest of the service at heart. The Secretary of the Navy approves such a policy of experimentation. The Congress of the United States, after carefully considering the matter, refused to authorize any further construction. Such a proposition must favorably commend itself to all fair-minded and business men, even though it may be opposed by those who have wares to sell.

AN APPROVED TYPE OF SUBMARINE HAS NOT YET BEEN DEVELOPED FOR  
THE NAVY.

The Navy can well afford to wait before settling upon an approved type of submarine boat. The more haste that is exercised, the more liable the naval service is to be misled by the promises of promoters.

There is practically no conflict of opinion in the Navy as to the value and efficiency of the battle ship. The same general testimony will be cheerfully paid to the work of the submarine when it is developed to a state where it is an efficient and reliable weapon of war.

No attempt has been made in this monograph to tell of the advantages of an efficient and reliable submarine. The possibilities are only limited by the imagination of the reader.

WASHINGTON CITY,

*June, 1902.*





HENRY A. ROWLAND.

Born, November 27, 1848; died, April 16, 1901.



## COMMEMORATION OF PROF. HENRY A. ROWLAND.<sup>a</sup>

By Dr. THOMAS C. MENDENHALL.

[The colleagues, pupils, and friends of the late Professor Rowland assembled Saturday, October 26, 1901, at 12 noon, in the lecture room of the physical laboratory, to commemorate the life and services of the distinguished physicist. An address, which is printed below, was delivered by Dr. Thomas C. Mendenhall, recently president of the Worcester Polytechnic Institute.]

### ADDRESS OF PROFESSOR MENDENHALL.

In reviewing the scientific work of Professor Rowland one is most impressed by its originality. In quantity, as measured by printed page or catalogue of titles, it has been exceeded by many of his contemporaries; in quality it is equaled by that of only a very, very small group. The entire collection of his important papers does not exceed 30 or 40 in number, and his unimportant papers were few. When, at the unprecedentedly early age of 33 years, he was elected to membership in the National Academy of Sciences, the list of his published contributions to science did not contain over a dozen titles, but any one of not less than a half-dozen of these, including what may properly be called his very first original investigation, was of such quality as to fully entitle him to the distinction then conferred.

Fortunately for him, and for science as well, he lived during a period of almost unparalleled intellectual activity, and his work was done during the last quarter of that century to which we shall long turn with admiration and wonder. During these twenty-five years the number of industrious cultivators of his own favorite field increased enormously, due in large measure to the stimulating effect of his own enthusiasm, and while there was only here and there one possessed of the divine afflatus of true genius, there were many ready to labor most assiduously in fostering the growth, development, and final fruition of germs which genius stopped only to plant. A proper estimate of the magnitude and extent of Rowland's work would require, therefore, a careful examination, analytical and historical,

<sup>a</sup> Reprinted, by permission, from Johns Hopkins University Circulars, Vol. XXI, No. 154, Baltimore, December, 1901.

of the entire mass of contributions to physical science during the past twenty-five years, many of his own being fundamental in character and far-reaching in their influence upon the trend of thought, in theory and in practice. But it was quality, not quantity, that he himself most esteemed in any performance; it was quality that always commanded his admiration or excited him to keenest criticism. No one recognized more quickly than he a real gem, however minute or fragmentary it might be, and by quality rather than by quantity we prefer to judge his work to-day, as he would himself have chosen.

Rowland's first contribution to the literature of science took the form of a letter to *The Scientific American*, written in the early autumn of 1865, when he was not yet 17 years old. Much to his surprise this letter was printed, for he says of it, "I wrote it as a kind of joke and did not expect them to publish it." Neither its humor nor its sense, in which it was not lacking, seems to have been appreciated by the editor, for by the admission of certain typographical errors he practically destroyed both. The embryo physicist got nothing but a little quiet amusement out of this, but in a letter of that day he declares his intention of some time writing a sensible article for the journal that so unexpectedly printed what he meant to be otherwise. This resolution he seems not to have forgotten, for nearly six years later there appeared in its columns what was, as far as is known, his second printed paper and his first serious public discussion of a scientific question. It was a keen criticism of an invention which necessarily involved the idea of perpetual motion, in direct conflict with the great law of the conservation of energy which Rowland had already grasped. It was, as might be expected, thoroughly well done, and received not a little complimentary notice in other journals. This was in 1871, the year following that in which he was graduated as a civil engineer from the Rensselaer Polytechnic Institute, and the article was written while in the field at work on a preliminary railroad survey. A year later, having returned to the institute as instructor in physics, he published in the *Journal of the Franklin Institute* an article entitled "Illustrations of resonances and actions of a similar nature," in which he described and discussed various examples of resonance or "sympathetic" vibration. This paper, in a way, marks his admission to the ranks of professional students of science and may be properly considered as his first formal contribution to scientific literature. His last was an exhaustive article on spectroscopy, a subject of which he, above all others, was master, prepared for a new edition of the *Encyclopædia Britannica*, not yet published. Early in 1873 the *American Journal of Science* printed a brief note by Rowland on the spectrum of the Aurora, sent in response to a kindly and always appreciated letter from Prof. George F. Barker, one of the editors of that journal. It is interesting as marking the beginning of his optical work. For a year, or perhaps for several

years, previous to this time, however, he had been busily engaged on what proved to be, in its influence upon his future career, the most important work of his life. To climb the ladder of reputation and success by simple, easy steps might have contented Rowland, but it would have been quite out of harmony with his bold spirit, his extraordinary power of analysis, and his quick recognition of the relation of things. By the aid of apparatus entirely of his own construction and by methods of his own devising, he had made an investigation both theoretical and experimental of the magnetic permeability and the maximum magnetization of iron, steel, and nickel, a subject in which he had been interested in his boyhood. On June 9, 1873, in a letter to his sister, he says: "I have just sent off the results of my experiments to the publisher and expect considerable from it; not, however, filthy lucre, but good, substantial reputation." What he did get from it, at first, was only disappointment and discouragement. It was more than once rejected because it was not understood, and finally he ventured to send it to Clerk Maxwell, in England, by whose keen insight and profound knowledge of the subject it was instantly recognized and appraised at its full value. Regretting that the temporary suspension of meetings made it impossible for him to present the paper at once to the Royal Society, Maxwell said he would do the next best thing, which was to send it to the *Philosophical Magazine* for immediate publication, and in that journal it appeared in August, 1873. Maxwell himself having corrected the proofs to avoid delay. The importance of the paper was promptly recognized by European physicists, and abroad, if not at home, Rowland at once took high rank as an investigator.

In this research he unquestionably anticipated all others in the discovery and announcement of the beautifully simple law of the magnetic circuit, the magnetic analogue of Ohm's law, and thus laid the foundation for the accurate measurement and study of magnetic permeability, the importance of which, both in theory and practice during recent years, it is difficult to overestimate. It has always seemed to me that when consideration is given to his age, his training, and the conditions under which his work was done, this early paper gives a better measure of Rowland's genius than almost any performance of his riper years. During the next year or two he continued to work along the same lines in Troy, publishing not many, but occasional, additions to and developments of his first magnetic research. There was also a paper in which he discussed Kohlrausch's determination of the absolute value of the Siemens unit of electrical resistance, foreshadowing the important part which he was to play in later years in the final establishment of standards for electrical measurement.

In 1875, having been appointed to the professorship of physics in the Johns Hopkins University, the faculty of which was just then being organized, he visited Europe, spending the better part of a year

in the various centers of scientific activity, including several months at Berlin in the laboratory of the greatest Continental physicist of his time, Von Helmholtz. While there he made a very important investigation of the magnetic effect of moving electrostatic charges, a question of first rank in theoretical interest and significance. His manner of planning and executing this research made a marked impression upon the distinguished director of the laboratory in which it was done, and, indeed, upon all who had any relations with Rowland during its progress. He found what Von Helmholtz himself had sought for in vain, and when the investigation was finished in a time which seemed incredibly short to his more deliberate and painstaking associates, the director not only paid it the compliment of an immediate presentation to the Berlin Academy, but voluntarily met all expenses connected with its execution.

The publication of this research added much to Rowland's rapidly growing reputation, and because of that fact, as well as on account of its intrinsic value, it is important to note that his conclusions have been held in question, with varying degrees of confidence, from the day of their announcement to the present. The experiment is one of great difficulty and the effect to be looked for is very small and therefore likely to be lost among unrecognized instrumental and observational errors. It was characteristic of Rowland's genius that with comparatively crude apparatus he got at the truth of the thing in the very start. Others who have attempted to repeat his work have not been uniformly successful, some of them obtaining a wholly negative result, even when using apparatus apparently more complete and effective than that first employed by Rowland. Such was the experience of Lecher in 1884, but in 1888 Röntgen confirmed Rowland's experiments, detecting the existence of the alleged effect. The result seeming to be in doubt, Rowland himself, assisted by Hutchinson, in 1889 took it up again, using essentially his original method, but employing more elaborate and sensitive apparatus. They not only confirmed the early experiments, but were able to show that the results were in tolerably close agreement with computed values. The repetition of the experiment by Himstedt in the same year resulted in the same way, but in 1897 the genuineness of the phenomenon was again called in question by a series of experiments made at the suggestion of Lippmann, who had proposed a study of the reciprocal of the Rowland effect, according to which variations of a magnetic field should produce a movement of an electrostatically charged body. This investigation, carried out by Crémieu, gave an absolutely negative result, and because the method was entirely different from that employed by Rowland, and therefore unlikely to be subject to the same systematic errors, it naturally had much weight with those who doubted his original conclusions. Realizing the necessity for addi-

tional evidence in corroboration of his views, in the fall of the year 1900 the problem was again attacked in his own laboratory, and he had the satisfaction, only a short time before his death, of seeing a complete confirmation of the results he had announced a quarter of a century earlier, concerning which, however, there had never been the slightest doubt in his own mind. It is a further satisfaction to his friends to know that a very recent investigation at the Jefferson Physical Laboratory of Harvard University, in which Rowland's methods were modified so as to meet effectually the objections made by his critics, has resulted in a complete verification of his conclusions.

On his return from Europe, in 1876, his time was much occupied with the beginning of the active duties of his professorship, and especially in putting in order the equipment of the laboratory over which he was to preside, much of which he had ordered while in Europe. In its arrangement a great many of his friends thought undue prominence was given to the workshop, its machinery, tools, and especially the men who were to be employed in it. He planned wisely, however, for he meant to see to it that much, perhaps most, of the work under his direction should be in the nature of original investigation, for the successful execution of which a well-manned and equipped workshop is worth more than a storehouse of apparatus already designed and used by others.

He shortly found leisure, however, to plan an elaborate research upon the mechanical equivalent of heat, and to design and supervise the construction of the necessary apparatus for a determination of the numerical value of this most important physical constant, which he determined should be exhaustive in character and, for some time to come, at least, definitive. While this work lacked the elements of originality and boldness of inception by which many of his principal researches are characterized, it was none the less important. While doing over again what others had done before him, he meant to do it, and did do it, on a scale and in a way not before attempted. It was one of the *great* constants of nature, and, besides, the experiment was one surrounded by difficulties so many and so great that few possessed the courage to undertake it with the deliberate expectation of greatly excelling anything before accomplished. These things made it attractive to Rowland.

The overthrow of the materialistic theory of heat, accompanied as it was by the experimental proof of its real nature, namely, that it is essentially molecular energy, laid the foundation for one of those two great generalizations in science which will ever constitute the glory of the nineteenth century. The mechanical equivalent of heat, the number of units of work necessary to raise 1 pound of water  $1^{\circ}$  in temperature, has, with much reason, been called the golden number of that century. Its determination was begun by an American, Count Rum-

ford, and finished by Rowland nearly a hundred years later. In principle the method of Rowland was essentially that of Rumford. The first determination was, as we now know, in error by nearly 40 per cent; the last is probably accurate within a small fraction of 1 per cent. Rumford began the work in the ordnance foundry of the Elector of Bavaria, at Munich, converting mechanical energy into heat by means of a blunt boring tool in a cannon surrounded by a definite quantity of water, the rise in temperature of which could be measured. Rowland finished it in an establishment founded for and dedicated to the increase and diffusion of knowledge, aided by all the resources and refinements in measurement which a hundred years of exact science had made possible. As the mechanical theory of heat was the germ out of which grew the principle of the conservation of energy, an exact determination of the relation of work and heat was necessary to a rigorous proof of that principle, and Joule, of Manchester, to whom belongs more of the credit for this proof than to any other one man, or, perhaps, to all others put together, experimented on the mechanical equivalent of heat for more than forty years. He employed various methods, finally recurring to the early method of heating water by friction, improving on Rumford's device by creating friction in the water itself. Joule's last experiments were made in 1878, and most of Rowland's work was done in the year following. It excelled that of Joule, not only in the magnitude of the quantities to be observed, but especially in the greater attention given to the matter of thermometry. In common with Joule and other previous investigators, he made use of mercury thermometers, but this was only for convenience, and they were constantly compared with an air thermometer, the results being finally reduced to the absolute scale. By experimenting with water at different initial temperatures he obtained slightly different values for the mechanical equivalent of heat, thus establishing beyond question the variability of the specific heat of water. Indeed, so carefully and accurately was the experiment worked out that he was able to draw the variation curve and to show the existence of a minimum value at 30° C.

This elaborate and painstaking research, which is now classical, was everywhere awarded high praise. It was published in full by the American Academy of Arts and Sciences with the aid of a fund originally established by Count Rumford, and in 1881 it was crowned as a prize essay by the Venetian Institute. Its conclusions have stood the test of twenty years of comparison and criticism.

In the meantime Rowland's interest had been drawn, largely perhaps through his association with his then colleague, Professor Hastings, toward the study of light. He was an early and able exponent of Maxwell's magnetic theory, and he published important theoretical discussions of electro-magnetic action. Recognizing the paramount importance of the spectrum as a key to the solution of problems in

ether physics, he set about improving the methods by which it was produced and studied, and was thus led into what will probably always be regarded as his highest scientific achievement.

At that time the almost universally prevailing method of studying the spectrum was by means of a prism or a train of prisms. But the prismatic spectrum is abnormal, depending for its character largely upon the material made use of. The normal spectrum as produced by a grating of fine wires or a close ruling of fine lines on a plane reflecting or transparent surface had been known for nearly a hundred years, and the colors produced by scratches on polished surfaces were noted by Robert Boyle more than two hundred years ago. Thomas Young had correctly explained the phenomenon according to the undulatory theory of light, and gratings of fine wire and, later, of rulings on glass were used by Fraunhofer, who made the first great study of the dark lines of the solar spectrum. Imperfect as these gratings were, Fraunhofer succeeded in making with them some remarkably good measures of the length of light waves, and it was everywhere admitted that for the most precise spectrum measurements they were indispensable. In their construction, however, there were certain mechanical difficulties which seemed for a time to be insuperable. There was no special trouble in ruling lines as close together as need be; indeed, Nobert, who was long the most successful maker of ruled gratings, had succeeded in putting as many as 100,000 in the space of a single inch. The real difficulty was in the lack of uniformity of spacing, and on uniformity depended the perfection and purity of the spectrum produced. Nobert jealously guarded his machine and method of ruling gratings as a trade secret, a precaution hardly worth taking, for before many years the best gratings in the world were made in the United States.

More than thirty years ago an amateur astronomer in New York City, a lawyer by profession, Lewis M. Rutherford, became interested in the subject and built a ruling engine of his own design. In this machine the motion of the plate on which the lines were ruled was produced at first by a somewhat complicated set of levers, for which a carefully made screw was afterwards substituted. Aided by the skill and patience of his mechanic, Chapman, Rutherford continued to improve the construction of his machine until he was able to produce gratings on glass and on speculum metal far superior to any made in Europe. The best of them, however, were still faulty in respect to uniformity of spacing, and it was impossible to cover a space exceeding two or three square inches in a satisfactory manner. When Rowland took up the problem, he saw, as, indeed, others had seen before him, that the dominating element of a ruling machine was the screw by means of which the plate or cutting tool was moved along. The ruled grating would repeat all of the irregularities of this screw

and would be good or bad just as these were few or many. The problem was, then, to make a screw which would be practically free from periodic and other errors, and upon this problem a vast amount of thought and experiment had already been expended. Rowland's solution of it was characteristic of his genius; there were no easy advances through a series of experiments in which success and failure mingled in varying proportions; "fire and fall back" was an order which he neither gave nor obeyed, capture by storm being more to his mind. He was by nature a mechanician of the highest type, and he was not long in devising a method for removing the irregularities of a screw, which astonished everybody by its simplicity and by the all but absolute perfection of its results. Indeed, the very first screw made by this process ranks to-day as the most perfect in the world. But such an engine as this might only be worked up to its highest efficiency under the most favorable physical conditions, and in its installation and use the most careful attention was given to the elimination of errors due to variation of temperature, earth tremors, and other disturbances. Not content, however, with perfecting the machinery by which gratings were ruled, Rowland proceeded to improve the form of the grating itself, making the capital discovery of the concave grating, by means of which a large part of the complex and otherwise troublesome optical accessories to the diffraction spectroscopy might be dispensed with. Calling to his aid the wonderful skill of Brashear in making and polishing plane and concave surfaces, as well as the ingenuity and patience of Schneider, for so many years his intelligent and loyal assistant at the lathe and workbench, he began the manufacture and distribution, all too slowly for the anxious demands of the scientific world, of those beautifully simple instruments of precision which have contributed so much to the advance of physical science during the past twenty years. While willing and anxious to give the widest possible distribution to these gratings, thus giving everywhere a new impetus to optical research, Rowland meant that the principal spoils of the victory should be his, and to this end he constructed a diffraction spectrometer of extraordinary dimensions and began his classical researches on the solar spectrum. Finding photography to be the best means of reproducing the delicate spectral lines shown by the concave grating, he became at once an ardent student and, shortly, a master of that art. The outcome of this was that wonderful "Photographic Map of the Normal Solar Spectrum," prepared by the use of concave gratings 6 inches in diameter and  $21\frac{1}{2}$  feet radius, which is recognized as a standard everywhere in the world. As a natural supplement to this he directed an elaborate investigation of absolute wavelengths, undertaking to give, finally, the wave-length of not only every line of the solar spectrum, but also of the bright lines of the principal elements, and a large part of this monumental task is already completed, mostly by Rowland's pupils and in his laboratory.



Time will not allow further expositions of the important consequences of his invention of the ruling engine and the concave grating.

Indeed, the limitations to which I must submit compel the omission of even brief mention of many interesting and valuable investigations relating to other subjects begun and finished during these years of activity in optical research, many of them by Rowland himself and many of them by his pupils, working out his suggestions and constantly stimulated by his enthusiasm. A list of titles of papers emanating from the physical laboratory of the Johns Hopkins University during this period would show somewhat of the great intellectual fertility which its director inspired, and would show, especially, his continued interest in magnetism and electricity, leading to his important investigations relating to electric units and to his appointment as one of the United States delegates at important international conventions for the better determination and definition of these units. In 1883 a committee appointed by the Electrical Congress of 1881, of which Rowland was a member, adopted 106 centimeters as the length of the mercury column equivalent to the absolute ohm, but this was done against his protest, for his own measurements showed that this was too small by about three-tenths of 1 per cent. His judgment was confirmed by the chamber of delegates of the International Congress of 1893, of which Rowland was himself president, and by which definitive values were given to a system of international units.

Rowland's interest in applied science can not be passed over, for it was constantly showing itself, often, perhaps, unbidden, an unconscious bursting forth of that strong engineering instinct which was born in him, to which he often referred in familiar discourse, and which would unquestionably have brought him great success and distinction had he allowed it to direct the course of his life. Although everywhere looked upon as one of the foremost exponents of pure science, his ability as an engineer received frequent recognition in his appointment as expert and counsel in some of the most important engineering operations in the latter part of the century. He was an inventor, and might easily have taken first rank as such had he chosen to devote himself to that sort of work. During the last few years of his life he was much occupied with the study of alternating electric currents and their application to a system of rapid telegraphy of his own invention. A year ago his system received the award of a grand prix at the Paris Exposition, and only a few weeks after his death the daily papers published cablegrams from Berlin announcing its complete success as tested between Berlin and Hamburg, and also the intention of the German postal department to make extensive use of it.

But behind Rowland, the profound scholar and original investigator, the engineer, mechanic, and inventor, was Rowland the man, and any

estimate of his influence in promoting the interests of physical science during the last quarter of the nineteenth century would be quite inadequate if not made from that point of view. Born at Honesdale, Pennsylvania, on November 27, 1848, he had the misfortune, at the age of 11 years, to lose his father by death. This loss was made good, as far as it is possible to do so, by the loving care of mother and sisters during the years of his boyhood and youthful manhood. From his father he inherited his love for scientific study, which from the very first seems to have dominated all of his aspirations, directing and controlling most of his thoughts. His father, grandfather, and great-grandfather were all clergymen and graduates of Yale College. His father, who is described as one "interested in chemistry and natural philosophy, a lover of nature and a successful trout fisherman," had felt, in his early youth, some of the desires and ambitions that afterwards determined the career of his distinguished son, but yielding, no doubt, to the influence of family tradition and desire, he followed the lead of his ancestors. It is not unlikely, and it would not have been unreasonable, that similar hopes were entertained in regard to the future of young Henry, and his preparatory school work was arranged with this in view. Before being sent away from home, however, he had quite given himself up to chemical experiments, glass blowing, and other similar occupations, and the members of his family were often summoned by the enthusiastic boy to listen to lectures which were fully illustrated by experiments, not always free from prospective danger. His spare change was invested in copper wire and the like, and his first five-dollar bill brought him, to his infinite delight, a small galvanic battery. The sheets of the New York Observer, a treasured family newspaper, he converted into a huge hot-air balloon, which, to the astonishment of his family and friends, made a brilliant ascent and flight, coming to rest, at last, and in flames, on the roof of a neighboring house, and resulting in the calling out of the entire fire department of the town. When urged by his boy friends to hide himself from the rather threatening consequences of his first experiment in aeronautics, he courageously marched himself to the place where his balloon had fallen, saying, "No, I will go and see what damage I have done." When a little more than 16 years old, in the spring of 1865, he was sent to Phillips Academy at Andover to be fitted for entering the academic course at Yale. His time there was given entirely to the study of Latin and Greek, and he was in every way out of harmony with his environment. He seems to have quickly and thoroughly appreciated this fact, and his very first letter from Andover is a cry for relief. "Oh, take me home," is the boyish scrawl covering the last page of that letter, on another of which he says, "It is simply horrible; I can never get on here." It was not that he could not learn Latin and Greek if he was so minded, but that he had long ago become

wholly absorbed in the love of nature and in the study of nature's laws, and the whole situation was to his ambitious spirit most artificial and irksome. Time did not soften his feelings or lessen his desire to escape from such uncongenial surroundings, and, at his own request, Dr. Farrand, principal of the Academy at Newark, New Jersey, to which city the family had recently moved, was consulted as to what ought to be done. Fortunately for everybody, his advice was that the boy ought to be allowed to follow his bent, and, at his own suggestion, he was sent, in the autumn of that year, to the Rensselaer Polytechnic Institute at Troy, where he remained five years, and from which he was graduated as a civil engineer in 1870.

It is unnecessary to say that this change was joyfully welcomed by young Rowland. At Andover the only opportunity that had offered for the exercise of his skill as a mechanic was in the construction of a somewhat complicated device by means of which he outwitted some of his schoolmates in an early attempt to haze him, and in this he took no little pride. At Troy he gave loose rein to his ardent desires, and his career in science may almost be said to begin with his entrance upon his work there and before he was 17 year old.

He made immediate use of the opportunities afforded in Troy and its neighborhood for the examination of machinery and manufacturing processes, and one of his earliest letters to his friends contained a clear and detailed description of the operation of making railroad iron, the rolls, shears, saws, and other special machines being represented in uncommonly well-executed pen drawings. One can easily see in this letter a full confirmation of a statement that he occasionally made later in life, namely, that he had never seen a machine, however complicated it might be, whose working he could not at once comprehend. In another letter, written within a few weeks of his arrival in Troy, he shows in a remarkable way his power of going to the root of things, which even at that early age was sufficiently in evidence to mark him for future distinction as a natural philosopher. On the river he saw two boats, equipped with steam pumps, engaged in trying to raise a half-sunken canal boat by pumping the water out of it. He described engines, pumps, etc., in much detail, and adds, "But there was one thing that I did not like about it; they had the end of their discharge pipe about 10 feet above the water, so that they had to overcome a pressure of about 5 pounds to the square inch to raise the water so high, and yet they let it go after they got it there, whereas if they had attached a pipe to the end of the discharge pipe and let it hang down into the water, the pressure of water on that pipe would just have balanced the 5 pounds to the square inch in the other, so that they could have used larger pumps with the same engines and thus have got more water out in a given time."

The facilities for learning physics, in his day, at the Rensselaer Poly-

technic Institute were none of the best, a fact which is made the subject of keen criticism in his home correspondence, but he made the most of whatever was available and created opportunity where it was lacking. The use of a turning lathe and a few tools being allowed, he spent all of his leisure in designing and constructing physical apparatus of various kinds, with which he experimented continually. All of his spare money goes into this and he is always wishing he had more. While he pays without grumbling his share of the expense of a class supper, he can not help declaring that "it is an awful price for one night's pleasure; why, it would buy another galvanic battery." During these early years his pastime was the study of magnetism and electricity, and his lack of money for the purchase of insulated wire for electro-magnetic apparatus led him to the invention of a method of winding naked copper wire, which was later patented by some one else and made much of. Within six months of his entering the institute he had made a delicate balance, a galvanometer, and an electrometer, besides a small induction coil and several minor pieces. A few weeks later he announces the finishing of a Ruhmkorff coil of considerable power, a source of much delight to him and to his friends. In December, 1866, he began the construction of a small but elaborately designed steam engine which ran perfectly when completed and furnished power for his experiments. A year later he is full of enthusiasm over an investigation which he wishes to undertake to explain the production of electricity when water comes in contact with red-hot iron, which he attributes to the decomposition of a part of the water. Along with all of this and much more he maintains a good standing in his regular work in the institute, in some of which he is naturally the leader. He occasionally writes: "I am head of my class in mathematics;" or "I lead the class in natural philosophy;" but official records show that he was now and then "conditioned" in subjects in which he had no special interest. As early as 1868, before his 20th birthday, he decided that he must devote his life to science. While not doubting his ability "to make an excellent engineer," as he declares, he decides against engineering, saying: "You know that from a child I have been extremely fond of experiment; this liking instead of decreasing has gradually grown upon me until it has become a part of my nature, and it would be folly for me to attempt to give it up; and I don't see any reason why I should wish it, unless it be avarice, for I never expect to be a rich man. I intend to devote myself hereafter to science. If she gives me wealth, I will receive it as coming from a friend; but if not, I will not murmur."

He realized that his opportunity for the pursuit of science was in becoming a teacher; but no opening in this direction presenting itself, he spent the first year after graduation in the field as a civil engineer. This was followed by a not very inspiring experience as instructor in

natural science in a Western college, where he acquired, however, experience and useful discipline.

In the spring of 1872 he returned to Troy as instructor in physics, on a salary the amount of which he made conditional on the purchase by the institute of a certain number of hundreds of dollars' worth of physical apparatus. If they failed in this, as afterwards happened, his pay was to be greater, and he strictly held them to the contract. His three years at Troy as instructor and assistant professor were busy, fruitful years. In addition to his regular work he did an enormous amount of study, purchasing for that purpose the most recent and most advanced books on mathematics and physics. He built his electro-dynamometer and carried out his first great research. As already stated, this quickly brought him reputation in Europe and what he prized quite as highly, the personal friendship of Maxwell, whose ardent admirer and champion he remained to the end of his life. In April, 1875, he wrote: "It will not be very long before my reputation reaches this country;" and he hoped that this would bring him opportunity to devote more of his time and energy to original research.

This opportunity for which he so much longed was nearer at hand than he imagined. Among the members of the visiting board at the West Point Military Academy in June, 1875, was one to whom had come the splendid conception of what was to be at once a revelation and a revolution in methods of higher education. In selecting the first faculty for an institution of learning which within a single decade was to set the pace for real university work in America, and whose influence was to be felt in every school and college of the land before the end of the first quarter of a century, Dr. Gilman was guided by an instinct which more than all else insured the success of the new enterprise. A few words about Rowland from Professor Michie, of the Military Academy, led to his being called to West Point by telegraph, and on the banks of the Hudson these two walked and talked, "he telling me," Dr. Gilman has said, "his dreams for science and I telling him my dreams for higher education." Rowland, with characteristic frankness, writes of this interview: "Professor Gilman was very much pleased with me;" which, indeed, was the simple truth. The engagement was quickly made. Rowland was sent to Europe to study laboratories and purchase apparatus, and the rest is history already told and everywhere known.

Rowland's personality was in many respects remarkable. Tall, erect, and lithe in figure, fond of athletic sports, there was upon his face a certain look of severity which was, in a way, an index of the exacting standard he set for himself and others. It did not conceal, however, what was, after all, his most striking characteristic, namely, a perfectly frank, open, and simple straightforwardness in thought, in speech; and in action. His love of truth held him in supreme control,

and, like Galileo, he had no patience with those who try to make things appear otherwise than as they actually are. His criticisms of the work of others were keen and merciless, and sometimes there remained a sting of which he himself had not the slightest suspicion. "I would not have done it for the world," he once said to me after being told that his pitiless criticism of a scientific paper had wounded the feelings of its author. As a matter of fact, he was warm-hearted and generous, and his occasionally seeming otherwise was due to the complete separation, in his own mind, of the product and the personality of the author. He possessed that rare power, habit in his case, of seeing himself, not as others see him, but as he saw others. He looked at himself and his own work exactly as if he had been another person, and this gave rise to a frankness of expression regarding his own performance which sometimes impressed strangers unpleasantly, but which, to his friends, was one of his most charming qualities. Much of his success as an investigator was due to a firm confidence in his own powers, and in the unerring course of the logic of science which inspired him to cling tenaciously to an idea when once he had given it a place in his mind. At a meeting of the National Academy of Sciences in the early days of our knowledge of electric generators he read a paper relating to the fundamental principles of the dynamo. A gentleman who had had large experience with the practical working of dynamos listened to the paper, and at the end said to the academy that unfortunately practice directly contradicted Professor Rowland's theory, to which instantly replied Rowland, "So much the worse for the practice," which, indeed, turned out to be the case.

Like all men of real genius, he had phenomenal capacity for concentration of thought and effort. Of this, one who was long and intimately associated with him remarks, "I can remember cases when he appeared as if drugged from mere inability to recall his mind from the pursuit of all-absorbing problems, and he had a triumphant joy in intellectual achievement such as we would look for in other men only from the gratification of an elemental passion." So completely consumed was he by fires of his own kindling that he often failed to give due attention to the work of others, and some of his public utterances give evidence of this curious neglect of the historic side of his subject.

As a teacher his position was quite unique. Unfit for the ordinary routine work of the class room, he taught, as more men ought to teach, by example rather than by precept. Says one of his most eminent pupils, "Even of the more advanced students only those who were able to brook severe and searching criticism reaped the full benefit of being under him, but he contributed that which, in a university, is above all teaching of routine—the spectacle of scientific work thoroughly done and the example of a lofty ideal."

Returning home about twenty years ago, after an expatriation of

several years, and wishing to put myself in touch with the development of methods of instruction in physics, and especially in the equipment of physical laboratories, I visited Rowland very soon after, as it happened, the making of his first successful negative of the solar spectrum. That he was completely absorbed in his success was quite evident, but he also seemed anxious to give me such information as I sought. I questioned him as to the number of men who were to work in his laboratory, and, although the college year had already begun, he appeared to be unable to give even an approximate answer. "And what will you do with them?" I said. "Do with them?" he replied, raising the still dripping negative so as to get a better light through its delicate tracings, "Do with them? I shall neglect them." The whole situation was intensely characteristic, revealing him as one to whom the work of a drillmaster was impossible, but ready to lead those who would be led and could follow. To be neglected by Rowland was often, indeed, more stimulating and inspiring than the closest personal supervision of men lacking his genius and magnetic fervor.

In the fullness of his powers, recognized as America's greatest physicist, and one of a very small group of the world's most eminent, he died on April 16, 1901, from a disease the relentless progress of which he had realized for several years and opposed with a splendid but quiet courage.

It was Rowland's good fortune to receive recognition during his life in the bestowal of degrees by higher institutions of learning; in election to membership in nearly all scientific societies worthy of note in Europe and America; in being made the recipient of medals of honor awarded by these societies, and in the generously expressed words of his distinguished contemporaries. It will be many years, however, before full measure can be had of his influence in promoting the interests of physical science, for with his own brilliant career, sufficient of itself to excite our profound admiration, must be considered that of a host of other, younger, men who lighted their torches at his flame and who will reflect honor upon him whose loss they now mourn by passing on something of his unquenchable enthusiasm, something of his high regard for pure intellectuality, something of his love of truth and his sweetness of character and disposition.





# INDEX.

## A.

	Page
Abbot, C. G., on some recent astronomical events .....	153-169
on solar eclipse of 1901.....	45, 124, 161
report on Astrophysical Observatory by.....	119-128
Abbott, James Francis, paper by .....	138
Abbott, W. L., collections from .....	33, 56, 475-492
exploration of Andaman Islands by.....	475-492
Abnaki Indians, study of .....	66
Adams, Charles Francis, paper by.....	140
Adams, Robert, jr., at meeting of Regents .....	xiii
Regent of the Institution.....	xii, 7
Adams, W. Irving, European trip of.....	51
on European exchange service.....	88-92
Adler, Cyrus, librarian's report by .....	126-128
on international catalogue of scientific literature.....	23
paper by .....	136
Administration, Secretary's report on.....	7
Aerodrome, Langley's, and pterodactyl .....	650
Aerodynamics, Langley's experiments in .....	xix, 11, 133, 649
Aeronautics, Janssen on progress in .....	133
Aflalo, F. G., on some private zoos .....	689
Africa, from Cape to Cairo .....	134
okapi discovered in.....	661-666
wonderful animals of .....	661
Age of the earth, Chamberlain on .....	131
Joly on .....	131
Kelvin on.....	131
Air, liquid, researches with .....	251
motion of particle of, in sound.....	15
currents, Marey's study of.....	14, 337
photographs of.....	337
pressure on bridges, researches in.....	353
Air-ship, Santos-Dumont's, circling Eiffel tower.....	575-592
description of .....	583
Zeppelin's .....	132, 577
Alaskan animals, preserve for, Dall on.....	43, 683-688
volcanoes, Merriam on.....	367-375
Albatross, power of flight of .....	654
Albatross, explorations by steamer .....	58
Alethorama of Chéri-Rosseau.....	328
Alpine tunnels, description of. ....	617-630
American Ethnology. ( <i>See</i> Bureau of.)	
Historical Association.....	140, 150
history collections, additions to.....	57

	Page.
Americanists, congress of, representatives to .....	26
Analysis of matter, Rucker on .....	175
Andaman Islands, Abbott collection from .....	56, 475-492
description of .....	475
origin of people of .....	478
savage people of .....	476
Anderson, T. D., new star discovered by .....	167
Andrew bequest, report on .....	xvi
Angell, James B., at meeting of Regents .....	xiii
Regent of the Institution .....	xii, 7
Animal motion, photography of .....	318
Animals and plants, mutation theory of .....	637
domestic, importance of .....	698
Anschütz's animal-motion pictures .....	319
Antarctic voyage of Belgica .....	377-388
Antelope, danger of extinction of .....	699
in Yellowstone Park .....	706
method of signaling by .....	705
Anthony, William A., on trans-Atlantic telephoning .....	299-306
Anthropology, papers on .....	132
Ants, white, habits of .....	667
Haviland on .....	667-678
nests of .....	675
Appalachian forest reserve .....	402
Appropriations, executive committee report on .....	xxv-lvi
under direction of Smithsonian Institution .....	xxv, 9
Aquarium in Zoological Park .....	107
Archæological discoveries in Crete .....	425
explorations .....	xx, 5, 37, 66
Architecture, ancient Cretan .....	433
Arctic and antarctic glaciers .....	380
expedition, collections by .....	58
exploration .....	68, 134
Arctowski, Henryk, on voyage of Belgica .....	377-388
Arid lands, area of .....	409
laws governing .....	417
Arizona, explorations in .....	37, 67
Armstrong, Professor, quoted .....	343
Arrows, Andamanese .....	485
Ashmead, William H., collections in Hawaii by .....	60
paper by .....	137
Astronomical events, Abbot on .....	153-169
photography, advances in .....	155
Astronomy, progress in .....	133
Astrophysical Observatory, appropriation for .....	xlvi, lix, 9
delicacy of galvanometer in .....	120
eclipse expedition of .....	124, 162
finances of .....	xlvi
moon radiation observations by .....	120
publication by .....	119
report on work of .....	119-128, 149
Secretary's report on .....	44
solar atmosphere observations by .....	123

	Page.
Atmosphere, constitution of .....	175
electrified, study of .....	13
exploration of, by kites at sea .....	245
Atmospheric air, researches in .....	13, 15
Atomic corpuscles, Röntgen rays vibration of .....	286
theory, Rucker on range of .....	182
volumes of gases .....	261
Atoms, and ether, nature of .....	176
bodies smaller than .....	231-243
properties of .....	184
Auriferous gravel man, Holmes on .....	132
Auroraborealis, origin of .....	242
Austin and Thwing, experiments by .....	207
Austria-Hungary, exchange service with .....	88
Automobile, bursting of .....	726
Henri Fournier on .....	593
races, Brooklyn .....	595
Paris-Berlin .....	606-609
Paris-Bordeaux .....	597-604
speed records in .....	595
Avery fund, statement of .....	xvi
B.	
Babylonian expedition of Edgar James Banks .....	xx, 5
Baird, Spencer F., Secretary of the Institution .....	148
Baker, B., air-pressure experiments by .....	353
Baker, Frank, on operations of Zoological Park .....	105-118
superintendent of Zoological Park .....	701
Ball, Sir Robert, on Mars .....	133
Balloon, Santos-Dumont's, circling Eiffel tower .....	575
Zeppelin's .....	132, 133, 577
Banks, Edgar James, Babylonian explorations by .....	xx, 5
Banks, Nathan, paper by .....	138
Barnard, Professor, eclipse observations by .....	162, 166
Barrows, W. E., minerals from .....	60
Barus, Carl, researches in ionized air by .....	13, 129
Basket work of Andamanese .....	483
Bean, Barton A., fishes collected by .....	61
Bears, care of captive .....	713
Belgica, Antarctic voyage of .....	377-388
Bell, Alexander Graham, at meeting of Regents .....	xiii
cash from .....	lvi
member of executive committee .....	xii
on telegraphone .....	307
on students' use of Government departments .....	xviii, 4
presents executive committee report .....	xv, lvi
Regent of the Institution .....	xii, 7
reports presented by .....	3
Wilson resolutions by .....	xiii, 51
Bell, James M., Philippine collections from .....	56
Bendire, Maj. Charles .....	64
Benedict, J. E., collections by .....	61
paper by .....	138

	Page.
Benson, H. C., birds presented by .....	58
Bequests, permanent committee report on .....	xvi
Berliner, Solomon, Lanzasotte pigeons from .....	109
Berry, F. V., on London exchanges .....	87
Bevier, Louis, analysis of vowel sounds by .....	13
Bibliography, chemical dissertations .....	19, 129
scientific literature .....	xxi, 6, 23, 127
Billings, John S., on progress in medicine .....	135
Biological collections in National Museum .....	57
Biology in nineteenth century .....	134
list of papers on .....	136, 137
Birds and eggs for scientific purposes, legislation on .....	lx
care of captive .....	714
destroyed by forest destruction .....	404
house for, in Zoological Park .....	106
in children's room .....	557
life histories of .....	63
origin of .....	639
photographs of motions of .....	332
relative power of flight of .....	651, 654
sense of smell in .....	132
soaring and flapping compared .....	652
the greatest of .....	649
Blumentritt, Ferdinand, paper by .....	132
Boas, Franz, Indian studies by .....	79
on mind of primitive man .....	451-460
Bodies smaller than atoms, Thomson on .....	231-243
Bogoslof volcanoes, C. Hart Merriam on .....	367-375
Bolometer, extreme sensitiveness of .....	46
invented by S. P. Langley .....	46
Bolton, H. C., bibliography by .....	19, 129
on radio-active substances .....	131
Bonaparte, Prince Roland .....	578
Books, appropriations for .....	xlvi, 10
Boomerangs, Gilbert T. Walker on .....	515-521
forms and use of .....	515-521
Booth, Charles, on normal classes of men .....	526
Bororo Indians, study of .....	56
Botany, papers on .....	131, 139
Bows and arrows, Andamanese .....	482, 484
Boyle, Sir Courtenay, death of .....	342
Boys, C. B., radiomicrometer of .....	157
Boys's researches in gravitation .....	201
Brandt, Karl, paper by .....	134
Braun, Dr., gravitation experiments of .....	203
Brazil, Indian collections from .....	56
Bridge, Gokteik, erection of .....	611-615
Brontosaurus, description of .....	642
Brooks, William K., on Huxley .....	135
Buffalo, extinction of .....	40, 699
water, domestication of .....	680
wanderings of .....	679-682
Buffalo Exposition, report on .....	63

	Page.
Building, National Museum .....	54
new one needed .....	30, 151
size and cost of .....	32
Secretary's report on .....	8, 30
Bunnell, J. H., & Co., collections from .....	57
Bunsen memorial lecture .....	133
Burdon-Sanderson, J., paper by .....	132
Burton, Opitz, Dr., at Smithsonian Naples table .....	16
Bureau of American Ethnology, appropriation for .....	XXVIII, LIX, 9
finances of .....	XXVIII
publications of .....	83, 140
report on operations of .....	65-84
Secretary Langley on .....	36
work of .....	149
Busch, August, on moths .....	137
Bushy House, history of .....	344

## C.

California, ethnological explorations in .....	37, 60
Cambridge University, degree conferred on S. P. Langley by .....	xiv
Candle, Hough on development of .....	496
Canovetti, C., grant to .....	12
Carhart, Henry S., on the Reichsanstalt .....	134, 341
Carter, Martin J., Newfoundland caribou from .....	109
Carter, Paul B., collections from .....	55
Casanowicz, I. M., paper by .....	136
Cathode rays, attracted by magnet .....	277
electrified .....	277
Dastre on .....	271-286
discovery of .....	271
mechanical effects of .....	277
not luminous .....	272
particles emitted by .....	273
researches in .....	234, 275
velocity of .....	280
Cave pictures of animals in France .....	439
Cavendish's researches in gravitation .....	201
Ceratosaurus, nose-horned lizard .....	646
Chamberlain, T. C., paper by .....	131
Cheapest form of light, S. P. Langley on .....	19, 129
Chemical dissertations, Bolton's bibliography of .....	19, 129
Chemistry, progress in .....	133
Cherokee Indians, myths of .....	80
Children, worth of, to the nation .....	527
Children's room, Paine on .....	553-560
Rathbun on .....	53
Secretary Langley on .....	34
specimens in .....	53, 555
China, coal deposits in .....	263
loot of Pekin Observatory in .....	133
loot of summer palace in .....	135
United States and, Wu Ting Fang on .....	135
Chinese folklore, Williams on .....	20, 135
Chladni on meteorites .....	193

	Page.
Chronophotographic gun.....	329
Chronophotography, Marey on.....	317-340
methods of.....	317
of flying objects.....	332
of liquids in motion.....	331
scientific application of.....	329
Cinematograph, Lumière's.....	327
reflected wave fronts of.....	134
Civilized and primitive man compared.....	458
Clark, A. Howard, editor's report by.....	129-140
Secretary American Historical Association.....	140
Cliff houses of Arizona.....	67
Coal deposits of the world.....	263
supplies, limit of.....	263
Cockrell, Francis M., Smithsonian Regent.....	xii, 7
Cocopa Indians, collections from.....	82
habits of.....	71
study of.....	37
Coherer for wireless telegraphy.....	288
Coleman, J. W., meteorite from.....	60
Color photography, article on.....	135
Sir W. J. Herschel on processes of.....	313-316
Condor compared with pterodactyl.....	649
Congressional acts and resolutions concerning Smithsonian.....	LVII
Cook, W. A., collections from.....	56, 60
Coolidge, Dane, collections by.....	60
Coons, habits of.....	712
Cope, Edward D., on crocodilians, etc.....	136
Coquillet, D. W., paper by.....	139
Cornu, A., paper by.....	131
Coronal photographs.....	162
Corpuscles, atomic, Röntgen rays vibration of.....	286
cosmical effects produced by.....	242
electric, Thomson on.....	235
Correspondence, Secretary's report on.....	25
Correspondents, Smithsonian, number of.....	49, 86, 94
Cosmical effects produced by corpuscles.....	242
Crabs, hermit, Benedict on.....	138
Cretan Labyrinth, discovery of.....	426
system of writing, discovery of.....	428
Crete, excavations in.....	425
Crocodilians and lizards, Cope on.....	136
Crookes, Sir William, paper by.....	131
radiation researches by.....	271
Crookes tube, experiments with.....	274
origin of.....	271
Crosby, F. W., minerals from.....	60
Cuba, collections from.....	59
natural history explorations in.....	61
Cullom, Shelby M., Smithsonian Regent.....	xii, 7
Cunningham, E. S., leopards from.....	109
Curie, M. and Mme., researches by.....	241
Currie, Rolla P., paper by.....	137
Curtis, Thomas E., paper by.....	133

## D.

	Page.
Dall, William H., on preservation of marine animals of Northwest coast . . . . .	683-688
paper by . . . . .	137
Dalton's atomic theory . . . . .	171, 182
Darwin, Charles, evolution, theory of . . . . .	631
Darwin, George, researches by . . . . .	186
Darwinian theory, C. A. White on . . . . .	631
Dastre, A., on the new radiations . . . . .	271-286
on uses of salt . . . . .	561-574
Daughters of the American Revolution, report of . . . . .	140
Davidson, George, on Alaska volcanoes . . . . .	370
Deer, danger of extinction of . . . . .	699
De Leon, Perry M., animals from . . . . .	109
Delitzsch, Frederick, paper by . . . . .	135
Delprat, Th. F. A., courtesies from . . . . .	46
Density of hydrogen in different conditions . . . . .	260
Derby, Orville A., collections from . . . . .	56
Derox, Mr., courtesies from . . . . .	164
Deutsch, Henry, balloonist's prize by . . . . .	577
Development of illumination, Hough on . . . . .	493-500
primal shaping arts, Holmes on . . . . .	501-513
De Vries, Professor, mutation theory of . . . . .	631-640
Dewar, James, on liquid hydrogen . . . . .	131, 134
on solid hydrogen . . . . .	251-261
Dewey, Admiral, on value of submarine boat . . . . .	717
Diamonds, Brazilian . . . . .	359
emigrant, in America . . . . .	359-366
forms of . . . . .	361
Michigan and Oregon . . . . .	361
origin of, Hobbs on . . . . .	359
South African . . . . .	359
Ural Mountains . . . . .	359
Virginia and Georgia . . . . .	359
Wisconsin . . . . .	361
Dinosaurs, abundance of . . . . .	641
distribution of . . . . .	642
or terrible lizards, Lucas on . . . . .	641-647
size and shape of . . . . .	643
Dinsmore, Hugh A., at meeting of Regents . . . . .	xiii
Regent of the Institution . . . . .	xi, 7
Dog, Seton on origin of . . . . .	715
Dohrn, Dr., on Naples zoological station . . . . .	17
Domestic animals, importance of . . . . .	698
Dordogne, caves of, pictures in . . . . .	439
Doty, Lieutenant, Bogoslof volcanoes photographed by . . . . .	371
Drake, Noah Fields, fishes collected by . . . . .	138
Draper, Paul, member of Sumatra eclipse expedition . . . . .	45, 124
Dugmore, Radclyffe, papers by . . . . .	135
Dutch Government, courtesies from . . . . .	162
Dyar, Harrison G., on moths . . . . .	137

## E.

Earth, quantity of matter of . . . . .	206
Eastlake, W., shell collections from . . . . .	58

	Page.
Eclipse expedition to Sumatra .....	45, 124, 125, 161
Eclipse expeditions .....	xx
Ecuador, exchange service with .....	87
Edison's kinoscope, description of .....	327
Editor, report of .....	129-140
Egypt, Petrie's researches in .....	425
Egyptians, primitive, stone implements of .....	33, 57
Eiffel tower, Santos-Dumont circling .....	575-592
Eldridge, G. H., collections from .....	59
Electric corpuscles .....	234
current, centenary of .....	293
discharge in rarefied gases .....	273
fluid theory of Franklin .....	235
installation in museum .....	xl
traction in tunnels, need of .....	629
Electrical conductivity of metals .....	240
current, nature of .....	184
phenomena of animals and plants .....	131
researches by J. J. Thomson .....	233
standards, need of .....	357
Electricity, conducted through thin metals .....	239
free, in metals .....	238
in gases .....	183, 233
negative, consists of corpuscles .....	235
nineteenth century, progress in .....	134
positive, nature of .....	235
Pupin system of transmitting .....	299-306
Schumann's researches in .....	12
Electrified fog .....	183
Electro-magnetic field, Maxwell's theory of .....	287
Electromobile, race with .....	596
Electrostatic discharges, magnetic effect of .....	740
Elephant house needed in zoological park .....	110
Elk, former abundance of .....	697
Emigrant diamonds in America .....	359-366
Emmons, G. T., collections from .....	55, 60
Ericsson, John, on solar engines .....	265
Eriksson, Karl, okapi obtained by .....	662
Eros, planet, observations of .....	159
variations in light of .....	161
Eskimo traps, Mason on .....	468
Establishment, Smithsonian, functions of .....	1
members of .....	xi, 2
Estimates and appropriations for 1902 .....	10
Ether and gravitational matter through infinite space .....	215-230
universal, theory of .....	287
Everett, Willis E., researches by .....	68
Executive committee, members of .....	xii
report of .....	xv, xxv-lvi
Explorations by Bureau of Ethnology .....	36, 65-84
by National Museum .....	60
Secretary's report on .....	18
Exposition, Louisiana Purchase, law providing .....	Lxi



	Page
Exposition, Tennessee Centennial .....	LXI
World's Columbian, report on.....	LX
Expositions, Smithsonian exhibits at.....	26
Extinct animals, restoration of.....	134
Extinction of American animals, danger of.....	38
of marine animals of Northwest coast .....	683
of wild animals.....	699
F.	
Falkenberg, Paul, paper by .....	132
Farming area, increase in .....	413
Farrington, Oliver C., on meteorites .....	193-197
Fewkes, J. W., Indian studies by .....	69, 70
Fiji Islands, collections from .....	56
fire ceremony at .....	539
Finances, executive committee report on.....	XXV-LVI
Secretary's statement of.....	XXIII, 8
summary of.....	LVI
Firefly, used for illuminating.....	494
Fire making of Andamanese .....	482
Fireman, Peter, chemical geologist .....	54
Fire walk ceremony in Tahiti, S. P. Langley on .....	539-544
Fish Commission, collections from.....	33, 58
Fishes, memory of .....	132
papers on .....	138
Fishing traps of American Indians.....	468
Fiske, John, on Huxley .....	136
Fleming, Professor, quoted.....	287
Fletcher, Alice C., Indian studies by .....	68, 82
Flight, Lord Rayleigh on .....	133
mechanical, experiments in.....	133, 649
Florida, fishes from .....	61
Flügel, Felix, exchange agent.....	87
Flying creature, greatest, Langley on .....	649-654
Lucas on .....	654-659
machine, Langley's.....	133
machines, pterodactyl and .....	649
Fog, comparison of molecules and .....	183
Forbes, R. H., explorations by .....	67
Forest destruction, fauna and flora destroyed by.....	404
Merriam on .....	404, 405
Pinchot on .....	401-404
Forests, geological action of .....	403
Fossil plants, new collection of.....	59
rhinoceros, Lucas on.....	137
Fossils, new collections of.....	33, 59
giraffe-like .....	664
mutation theory of .....	638
Foster, Sir Michael.....	131, 171
Fournier, Henri, in automobile races .....	593-609
on automobile manufacture .....	593
Fowle, F. E., assistant in astrophysical observatory.....	125
Fox, Francis, on great Alpine tunnels.....	617-630

	Page.
Fox, Mr., agent for Avery property .....	xvi
France, exchange service with .....	92
Franklin's one-fluid theory .....	235
Frigate bird, Lucas on flight of .....	654
Frye, William P. ....	III, xiii
Fuel supplies of the world, Thurston on .....	263
Fuller, Melville W., Chancellor of the Institution .....	xii, 7
member of Smithsonian Establishment .....	xi, 2
Fulton, submarine boat, test of .....	722
Functional motions, photographs of .....	334
Fund, Smithsonian, statement of .....	xxiii, 6, 8
Fur seal, Dall on preservation of .....	685

## G.

Gage, Lyman J., member of Smithsonian Establishment .....	xi, 2
Galleries, National Museum, appropriation for .....	10
cost of .....	xlvi
Gallery of art, expenditures for .....	xxvi
Galton, Sir Douglas, on physical laboratory .....	341
Galton, Francis, on improvement of human breed .....	523-537
Galvanometer, improvements in .....	120
Garden and its development .....	132
Gases, atomic volumes of .....	261
electricity in .....	183, 233
experiments in solidifying .....	251
Gates, Peter G., explorations by .....	60
Gatschet, Albert S., Indian language studies by .....	79
Geographic conquests of nineteenth century .....	134
Geology, and mutation theory .....	638
increase of collections in .....	59
papers on .....	131, 134, 136
Georgia, Indian quarries in .....	60
Gevers, Baron W. A. F., courtesies from .....	45
Gibbs, Willard, researches by .....	174
Gila Valley, explorations in .....	67
Gill, De Lancey, explorations by .....	67
illustrative work of .....	84
Gill, Theodore N., paper by .....	139
representative to Glasgow University jubilee .....	26
Gilman, President, of Johns Hopkins University .....	749
Giraffe-like fossils .....	664
Glacial epoch in Antarctic region .....	383
Glaciers, Antarctic, form of .....	380
Glasgow University, jubilee of .....	26
Glazebrook, R. T., on national physical laboratory .....	341-357
Gokteik bridge, erection of .....	611-615
Gold and lead, interpenetration of .....	177
Gossart's oscillating objective photographs .....	328
Government Departments, utilization of, by students .....	xviii, lvii, 4
Gravitation, law of force of .....	199
recent studies in .....	199-214
Gravitational matter in infinite space .....	215
Gray, George, appointed Regent .....	xii, xiv, lvii, 3

	Page.
Gray, George, at meeting of Regents.....	viii
Grazing area of Western States.....	421
Greatest flying creature, Lucas on.....	654-659
S. P. Langley on.....	649-654
Greek civilization, origin of.....	426
Greeley colony in Colorado.....	422
Griggs, John W., member of Smithsonian Establishment.....	2
Grogan, Ewart S., on Africa.....	134
Gross, R. A., ions from.....	109
Grosvenor, Gilbert H., paper by.....	134
Grotto of La Mouthe, pictures in.....	439
Grye, Bouquet de la.....	578
Guatemala, early sculptures of.....	132
Gudgeon, Colonel, on fire-walk ceremony.....	539

## H.

Habel, Simeon, bequest of.....	xxv, 8
Hackett, F. W., courtesies from.....	45
report by.....	xvi
Haeckel, Professor, on life in ether and matter.....	188
Haiti, shells from.....	58
Hallock, William, researches in articulate sound by.....	15
Hamilton, James, bequest of.....	xxv, 8
Hammer, William J., on telephonograph.....	307-312
Harding, S. B., paper by.....	140
Harriman Alaska expedition.....	367
Hassler, Emil, collections from.....	56
Hatfield, Helen, birds from.....	109
Haurow, M. Ducos du, photographs by.....	319
Haviland, G. D., on habits of white ants.....	667
Hawaii, collections from.....	56, 61
Hay, John, member of Smithsonian Establishment.....	xi, 2
Healy, M. A., on Bogoslof volcano.....	371
Heat, mechanical equivalent of.....	741
Rumford on nature of.....	178
stellar, measure of.....	157
Heat motor, Thurston on.....	270
movements of matter.....	179
Hele-Shaw, H. S., experiments by.....	337
paper by.....	131
Henderson, J. B., chairman of executive committee.....	xii, lvi
Regent of the Institution.....	xii, xiii, 7
translation by.....	xiv
tribute to W. L. Wilson by.....	3, 51
Henderson, J. B. jr., collections by.....	58, 61
Henry, Joseph, laboratory notes of.....	26
on catalogue of scientific literature.....	6, 23
on Smithsonian library.....	xx
on Smithsonian reports.....	19
on theory of universal ether.....	287
Herbarium, National, additions to.....	58
Heredity, Galton on.....	528
Herisson, Count D', on loot of summer palace.....	135

	Page.
Herschel, Sir William J., on color photography.....	313-316
Hertwig, Oscar, paper by.....	134
Hertz, Heinrich, researches by.....	287
Hewitt, J. N. B., Indian researches by.....	67, 77
Hieroglyphic writing, Cretan.....	428
Hildebrandson, Professor, atmosphere experiments by.....	248
Hilder, F. F., Philippine collections by.....	60, 82
History, American, collections illustrating.....	57
Hitchcock, E. A., member of Smithsonian Establishment.....	XI, 2
Hitt, Robert R., member of Executive Committee.....	XII, XV, LV1
Regent of the Institution.....	XII, XIII, XIV, 7
reports by.....	3
Hittorf rays, Dastre on.....	272
Hobart, Jennie T.....	XIII
Hobart, Vice President, death of.....	XIII
member of Smithsonian Establishment.....	2
Hobbs, William Herbert, on American diamonds.....	359-366
Hocken, T. M., on fire walk ceremony.....	539
Hodge, F. W., editorial work of.....	83
report as Curator of Exchanges.....	85-104
representative to Congress of Americanists.....	26
work on Cyclopedia of Indian tribes by.....	82
Hodgkins, Thomas G., gift of.....	XXV, 8, 149
Hodgkins fund, conditions of grant from.....	15
research work under.....	11
statement of.....	XVI
Hofmann, O., insect collection of.....	58
Holland type of submarine boat, Melville on.....	718, 730
Holmes, W. H., collections by.....	57
explorations by.....	60
on auriferous gravel man.....	132
on primal shaping arts.....	501-513
report by.....	136
representative to Congress of Americanists.....	26
Hopi Indians, study of.....	70, 72
Hornaday, W. T., superintendent of National Zoological Park.....	701
Horse, prehistoric, picture of.....	446
Hough, Walter, explorations by.....	60
on development of illumination.....	493-500
paper by.....	136
Huggins, Sir William, on rings of Saturn.....	176
researches by.....	153, 154
Hughes, Professor, electrical researches by.....	287
Human breed, Galton on improvement of.....	523-537
mind, elements of activities of.....	452
qualities, distribution of.....	524
variety, Galton on.....	524
Hutton, F. W., collections from.....	59
Huxley, lesson of life of.....	135
reminiscences of.....	136
Hybridity, elementary.....	632
Hydrogen, density of, in different conditions.....	260
electricity in.....	233

	Page.
Hydrogen, liquid, density of .....	260
Dewar on .....	131
solid, method of making .....	251-261
Dewar on .....	251-261

## I.

Icebergs, antarctic, characteristics of .....	384
Illumination, development of, Hough on .....	493-500
Improvement of human breed, Galton on .....	523-537
Incandescent mantles .....	134
Income and expenditure, resolution concerning .....	xv
Smithsonian, present inadequacy of .....	xxiv
Indian collections in National Museum .....	55
Indians, American, types of .....	461-473
South American, collections from .....	56
traps of .....	461-473
Virginia, study of .....	67
Insects, increase in collections of .....	58
papers on .....	137, 667
International catalogue of scientific literature .....	xxi, 6, 23, 127
exchanges, appropriations for .....	xxvii, lvi, 9
correspondents of .....	86, 94
countries participating in .....	100
European agencies of .....	88
foreign government depositories of .....	103
Government documents sent by .....	96
number of parcels sent by .....	49
operations of .....	49, 85-104
receipts and disbursements of .....	xxvii
Secretary's report on .....	48
weight of transmissions by .....	86
Intramercurial planets, photographs of .....	120
Ionized air, researches by Barus in .....	13
atmosphere, observations on .....	243
gases, researches in .....	183
Iroquois Indians, study of .....	67
Irrigated and irrigable areas .....	410, 411, 412, 415
Irrigation, cost of .....	418
laws regulating .....	417
F. H. Newell on .....	407-423
Isopods of North America, Miss Richardson on .....	138
Italy, exchange service with .....	90
Ives's process of color photography .....	314

## J.

Japan, exchange service with .....	87
shells from .....	58
Janssen, on progress in aeronautics .....	133
Janssen's astronomical revolver .....	317
Jefferson, President, on meteorites .....	193
Jenks, Albert E., Indian researches by .....	72
Jennings, O. P., collections from .....	58
Jewish ceremonial objects .....	136

	Page.
Jockes, Governor, courtesies from.....	46
Johnston, Margaret A.....	XIII
Johnston, William Preston, death of.....	XIII
successor to.....	XIII
Johnston, Sir Harry H., on the Okapi.....	661-666
Joly, J., on age of the earth.....	131
Jordan, David Starr, papers by.....	138

## K.

Kadiak bear, efforts to secure.....	41
Keeler, Professor, nebulae photographs by.....	156
researches by.....	154
Keene, Foxhall P., automobile race by.....	596
Keller, M. I., Rocky Mountain sheep from.....	109
Kelvin, Lord, on age of the earth.....	131
on ether and gravitational matter through infinite space.....	215-230
on nature of matter.....	178, 179
cited.....	231
Kidder, J. H., cash from executors of.....	LVI
Kinetoscope, Edison's, description of.....	327
Kirchoff, Alfred, on sea in life of nations.....	389-399
Kites, experiments in Europe with.....	245
height attained by.....	13, 245
meteorological observations with.....	12, 133, 245
researches by Rotch with.....	12, 245
sea atmosphere explored with.....	245-249
Kloss, C. Boden, bird collection from.....	58
ethnological researches by.....	475
Knossos, ancient, excavation of.....	426
Knox, Philander C., member of Smithsonian Establishment.....	xi, 2
Koehler, S. R., death of.....	64
Kongo Free State, animals of.....	661
Körösy, Joseph von, exchange agent.....	87, 89
Krakatau, eruption of.....	163
Kropotkin, Prince, paper by.....	134

## L.

Labels, Museum, Secretary Langley on.....	33, 35, 554
Labyrinth, Cretan, discovery of.....	426
L'Aigle, fall of meteorites at.....	193
Lake, W. C., minerals from.....	60
Lamp, development of.....	498
La Mouthe, grotto, engraved pictures in.....	439
Lang, Andrew, on fire-walk ceremony.....	539
on psychical research.....	135
Langley, S. P., at meeting of Regents.....	XIII, 3
holometer invented by.....	46
degree conferred on, by Cambridge University.....	xiv, 3
honorary curator of children's room.....	553
on cheapest form of light.....	129
on chronophotography.....	337
on fire-walk ceremony in Tahiti.....	539-544
on greatest flying creature.....	649-654

	Page.
Langley, S. P., on inadequacy of Smithsonian fund .....	XXIII
on laws of nature .....	545-552
on solar eclipse of 1900 .....	133
on the new spectrum .....	135
report on operations of Institution by .....	1-140
Secretary of the Institution .....	vi, 149
secures establishment of National Zoological Park .....	700
voyage to Tahiti by .....	18
Langley aerodrome, description of .....	133
Lankester, Ray, on the Okapi .....	664
Lawless, Captain, at Tahiti .....	541
Laws of nature, S. P. Langley on .....	545-552
LeBon, Gustave, researches by .....	280
LeCointe, George, antarctic voyage by .....	378
LeConte, Joseph, paper by .....	134
Legislation for Smithsonian Institution .....	LVII
LeMesurier, E. A., letter concerning Smithson's remains .....	XIX
Lenard's molecular researches .....	237
Lennox, Robert, researches by .....	261
Lens, improvement in manufacture of .....	348
Lewes, Vivian B., paper by .....	134
Leyland, Christopher, private zoo of .....	691
Library, ancient Cretan .....	434
National Museum .....	64, 128
Secretary's report on .....	20
Smithsonian, report on .....	126-128
Library of Congress, Smithsonian deposit in .....	xx, 6, 22
Lick Observatory, Nova Persei observations at .....	168
Life, phenomena of, Rucker on .....	188
Light and electricity, identity of .....	288
Schumann's study of .....	12
cheapest form of .....	19, 129
polarized, mechanical energy of .....	217
undulatory theory of .....	131, 215
Lighting, primitive methods of .....	493
Lindsay, William, Smithsonian Regent .....	XII, XIII, 7
Line of sight determinations .....	154
Lippmann's process of color photography .....	316
Liquid air, researches with .....	251
hydrogen, Dewar on .....	134, 251, 252
motion of perfect .....	131
oxygen, Dewar on .....	252
Lizards, terrible, Lucas on .....	641-647
Lockyer, Sir Norman, paper by .....	133
on India famines .....	133
on star spectra .....	184
on star velocities .....	225
researches by .....	237
Londe, M., multiple photography by .....	223
London Zoo, Aflalo on .....	689
Long, John D., member of Smithsonian Establishment .....	vi, 2
Loot of Peking Observatory .....	133
summer palace at Peking .....	135

	Page.
Loper, S. Ward, fossils collected by .....	59
Loubat, Duc de, collection from .....	33, 55
Louisiana Purchase Exposition, law providing .....	LXI
Lucas, F. A., curator of comparative anatomy .....	64
mastodon collected by .....	61
on dinosaurs .....	641-647
on fossil rhinoceros .....	137
on greatest flying creature .....	654-659
on restoration of extinct animals .....	134
on the mammoth .....	132
Lucy, M. de, on wing surface of birds .....	653
Ludington, M. I., courtesies from .....	45
Lumière's cinematograph .....	327
Lydekker, R., on mammoth ivory .....	132
Lyle, Eugene P., jr., on Santos-Dumont balloon .....	575-592
Lyon, Marcus W., jr., animals obtained by .....	110
paper by .....	139
M.	
McGee, W. J., collections by .....	60
explorations by .....	66
on operations of Bureau of American Ethnology .....	65-84
McGuire, J. D., on pecking process of working stone .....	507
stone implements from .....	33, 57
McKinley, William, member of Smithsonian Establishment .....	xi, 2
McNeill, Jerome, paper by .....	138
Mach, L., researches by .....	337
Magnetic attraction of cathode rays .....	277
effect of electrostatic discharges .....	740
force, effects of variation in .....	183
permeability of metals, Rowland on .....	739
Magnetophonograph, Poulsen's .....	307
Mahan, Captain, on value of submarine boat .....	721
Makaroff, Vice-Admiral, paper by .....	134
Malaria transmitted by mosquitoes .....	135
Mammoth, preservation of, in Siberia .....	37
truth about, Lucas on .....	132
Mammoth-ivory, Lydekker on .....	132
Man, E. H., on Andaman Islands .....	476
Manatee, scarcity of .....	40
Manganese in meteorites .....	194
Marconi, G., experiments in trans-Atlantic telegraphing by .....	296
on wireless telegraphy .....	287-298
Marey, J., air-current photographs by .....	14, 337
grant to .....	14
history of chronophotography by .....	317-340
Marine animals of Northwest coast, Dall on preservation of .....	683-688
Mars, notes on, by Sir Robert Ball .....	133
Marshall Islands, sea charts of .....	132
Mason, O. T., on pictures in grotto of La Mouthe .....	439, 440
on traps of American Indians .....	461-473
paper by .....	136
Mass electrical in its origin .....	237



	Page.
Mastodon, skeleton of .....	33, 61
Matter, analysis of, Rucker on .....	175
coarse-grainedness of .....	177
mean density of ponderable .....	221
properties of the basis of .....	179
Maxon, William R., collections by .....	59, 61
paper by .....	139
Maxwell's dynamical theory .....	287
Maya language, study of .....	79
Mearns, E. A., collections by .....	58, 60
Mechanical equivalent of heat .....	741
Medicine, progress in nineteenth century .....	135
Melville, George W., on submarine boat as weapon of war .....	717-738
Mendenhall, Thomas C., address on Rowland by .....	739-753
paper by .....	134
Mensch, P. C., at Smithsonian Naples table .....	16
Merriam, C. Hart, on Bogosloff volcanoes .....	367-375
on forest destruction .....	404
Merrill, George P., on nonmetallic minerals .....	136
Mesopotamia, discoveries in .....	351
Metals, microscopic examination of .....	351
Meteoritic stones, composition of .....	194
Meteorites, analysis of .....	194
century of study of .....	193
composition of .....	194
fall of, in France .....	550
former disbelief in .....	193
lunar origin of .....	197
Museum collections of .....	194
new specimens of .....	60
number of .....	195
Meteorological observations with kites .....	12, 133, 245-249
studies by Von Lendenfeld .....	12
Microphonograph, Poulsen's .....	307
Microscopic chronophotography .....	329
examination of metals .....	351
Miller, Gerrit S., jr., collections by .....	60
Mills spectograph, work of .....	154
Mind of primitive man .....	451-460
Minerals, new collections of .....	60
Minos, palace of, excavation of .....	425-437
Miracles, gospel, Hume on .....	548
Model of Nature, by A. W. Rucker .....	171
Molecules, compared with fog .....	183
properties of .....	184
size of .....	186
Mollusks, new collections of .....	58
Moloch, Australian, description of .....	644
Monkeys, care of captive .....	711
Mont Cenis tunnel, description of .....	622
Moon radiations, researches in .....	120
Mooney, James, Indian studies by .....	67, 80
Moose, danger of extinction of .....	699

	Page.
Moose, present scarcity of .....	40
Morgan, Mrs. George W., collections from .....	57
Motor, petroleum, secret of power of .....	587
Mouillard on power of flight of birds .....	653
Mountain goat, danger of extinction of .....	699
Mount Dicta, great cave of .....	426
Mousterian epoch, pictures of .....	439
Murray, Sir John, paper by .....	131
Museum proposed at Santa Fe Palace .....	27
Mussels, fresh water, Simpson on .....	137
Mutation theory of Professor De Vries, by C. A. White .....	631-640
Muybridge's animal-motion pictures .....	318
Mycenæ, excavations at .....	425
Myths, Indian, study of .....	81

## N.

Naples Zoological Station, Smithsonian table at .....	15
Natick Indian dictionary, Trumbull's .....	79
National Museum, accessions to .....	33, 55
administration of .....	XXII, XXIII
appropriations for .....	XXX-XLVI, LV-LVIII, 10
Assistant Secretary Rathbun on .....	53-64
building, cost of .....	32
cubic contents of .....	32
need of new .....	30, 151
children's room of .....	53, 553-560
census of collections in .....	147
compared with other museums .....	31
Congressional acts concerning .....	LVIII
electric installation in .....	XL, 55
exchanges by .....	61
finances of .....	XXX-XLVII
galleries in .....	XLVI, 10, 54
larger appropriations needed for .....	30
lecture hall of .....	54
library of .....	64, 128
origin of .....	147
publications of .....	63, 137
scientific staff of .....	54
Secretary on needs of .....	XXII, 6, 30
Secretary's report on .....	29
visitors to .....	53, 148
National Physical Laboratory of Great Britain .....	341-357
National University, Mr. Bell on .....	XVIII
National Zoo at Washington, Ernest Thompson Seton on .....	697-716
National Zoological Park, animals in .....	105, 110, 111
animal quarters in .....	702
appropriation for .....	LIX, 10, 106
aquarium in .....	107
bird house in .....	106
elephant house needed in .....	110
finances of .....	XLIX
history of .....	700

	Page.
National Zoological Park, important accessions to.....	109
losses in.....	111
needs of.....	xiv, 110
new paddock in.....	107
object of.....	38, 149, 700
property of.....	105
report of Superintendent of.....	105-118
report of Secretary on.....	38
roadways in.....	108
Seton's description of.....	697-716
Nature, laws of, S. P. Langley on.....	545-552
model of, by A. W. Rucker.....	171
pictures, by Dugmore.....	135
Naval Observatory, solar eclipse expedition of.....	166
Navigation, history of.....	394
Navy Department, courtesies by.....	163
Nebula about Nova Persei.....	168
Nebulae, high temperature of.....	243
photographs of.....	156
Negritos of Andaman Islands.....	56, 478
of Nicobar Islands.....	56
Nelson, Elias, paper by.....	139
Netherlanders, effect of sea on.....	390
Newell, F. H., on irrigation.....	407-423
New Mexico, branch museum proposed in.....	27
New star in Perseus, observations on.....	167
Newton's studies in gravitation.....	200
Niagara water power, use of.....	264
Nichols, E. F., radiometer designed by.....	157
Nicobar Islands, Negritos of.....	56
Nitrogen, solid, Dewar on.....	252
Nobel, Alfred, bequest of.....	27
Nobel prize competition, terms of.....	26
Northwest coast animals, Dall on preservation of.....	683-688
Nova Persei, discovery of.....	167
O.	
Observatories, list of.....	129
Ocean, effect of, on life of nations.....	391
life in, Brandt on.....	134
Oceanic areas, Murray on.....	131
Oenothera, De Vries's experiments with.....	635
Okapi, Sir Harry H. Johnston on.....	661-666
size and coloration of.....	663
Olney, Richard, Regent of the Institution.....	xii, xiii, 7
Origin of species, Darwinian theory of.....	631
De Vries's mutation theory of.....	631
Ornithostoma, Lucas on.....	654-659
the greatest flying creature.....	649-659
Oxygen, liquid, researches with.....	252
P.	
Paine, Albert Bigelow, on children's room.....	553-560
Paintings, ancient Cretan.....	433

	Page.
Palace of Minos, Evans on.....	425-437
Paleolithic period in Europe.....	439
Palmer, William, collections by.....	59
Pamamary Indians, collections from.....	56
Pan-American Exposition, collections from.....	60
report on.....	63
Papago Indians, study of.....	66
Papi-Ita in fire walk ceremony.....	539-544
Pawnee Indian ceremonies, study of.....	68
Pearson, Karl, quoted.....	181
Pekin, loot of summer palace at.....	20, 135
Pekin Observatory, loot of.....	133
Peirce, Charles S., on great men of science.....	135
Permanent committee, report of.....	xvi
Perrin, Jean, researches by.....	286
Perrine, Mr., solar eclipse observations by.....	166
Perseus, new star in, observations on.....	167
Petersen, H. P., minerals from.....	60
Petrified forests of Arizona, Ward on.....	131
Phenomena of life, Rucker on.....	188
Philippines, collections from.....	56, 60
list of native tribes of.....	132
peopling of.....	132
Phillips, O. P., moving pictures by.....	68
Phillips, W. A., explorations by.....	60
Philology, studies in.....	78
Phonograph, magneto or micro.....	307
Phosorescence, forms of.....	494
Photographic gun, description of.....	322
lens, improvements in.....	348
Photography, astronomical, advances in.....	155
chrono, Marey on.....	317-340
color, article on.....	135
Herschel on.....	313-316
sound wave.....	134
spectrum.....	744
Physical Laboratory of Great Britain.....	341-357
theories, limits of.....	190
Physics, progress in, Mendendall on.....	134
Physiological uses of salt.....	561-574
Pickering, E. C.....	44
observations on planet Eros by.....	160
Pinchot, Gifford, on forest destruction.....	401-404
Planet Eros, observations of.....	159
Plants, electrical phenomena of.....	131
new collections of.....	59
Platt, Orville H., Regent of the Institution.....	xii, xiii, 7
Plumacher, E. H., crocodile from.....	109
Poincaré, Professor, on scientific methods.....	171
Pollard, C. L., collections by.....	59, 61
Porto Rico, collections from.....	33
Postage, Museum, appropriation for.....	10
Pottery, Andamanese.....	483

	Page.
Pottery, West Virginia, Hough on.....	136
Poulsen, Waldemar, magneto-phonograph of.....	307
Powell, J. W.....	36
on irrigation.....	418
representative to Congress of Americanists.....	26
Power, sources of, for industrial uses.....	263, 270
Poynting, John H., studies in gravitation by.....	199-214
Poynting, Professor, on scientific methods.....	171
Prehistoric-cave pictures.....	439
Preservation of animals from extinction.....	38
Primal shaping arts, Holmes on.....	501-513
Primitive man, the ocean and.....	396
mind of, Boas on.....	451-460
Printing, National Museum, appropriation for.....	LVIII, 10
expenditures for.....	XLII
Private zoos, Aflalo on.....	689
Prussian Academy, two hundredth anniversary of.....	XVII, 3
Psychical research, Andrew Lang on.....	135
Crookes on.....	131
Psychology and invention, study in.....	461
Pterodactyl, greatest flying creature, Langley on.....	649-654
Lucas on.....	654-659
Public lands of United States, vacant.....	407
Publications, American Historical Association.....	140
Bureau of American Ethnology.....	83, 140
Daughters of the American Revolution.....	140
editor's report on.....	129-140
expenditures for.....	XXVI
National Museum.....	63, 137
sale of.....	XXVI
Secretary's report on.....	18
Smithsonian.....	18, 129, 136, 148
Pupin, Dr. M. I., long-distance telephone system of.....	299
Putnam, F. W., paper by.....	132
R.	
Radiations, the new, by Dastre.....	271-286
unsuspected.....	134
Radio-active radium.....	234
substances, Bolton on.....	131
Radiomicrometer, designed by Boys.....	157
Radium corpuscles, velocity of.....	241
electric corpuscles from.....	241
Ralph, W. L., custodian.....	64
gift of bird's eggs by.....	58
on life histories of birds.....	63
Ramsay, William, paper by.....	133
Raspail, Xavier, paper by.....	132
Rathbun, Richard, Assistant Secretary of the Institution.....	VI, XXII, 64
report on National Museum by.....	53-64
Ralyeigh, Lord, cited.....	231
on flight.....	133
Recent astronomical events, Abbot on.....	153

	Page.
Regents, list of, dates of appointment.....	xii, xiii, 2, 7
proceedings of meeting of.....	xiii
Reichsanstalt, description of.....	341
Reports, Smithsonian, objects of.....	20
Researches, by Bureau of Ethnology.....	66
expenditures for.....	xxvi
Secretary's report on.....	11
Resonances, Rowland on.....	738
Reynders, J. V. W., bridge built by.....	611
Rhees, W. J., history of Smithsonian Institution by.....	19, 129
Rhodes, James Ford, paper by.....	140
Rice, William North, paper by.....	132
Richardson, Harriet, collaborator.....	54
on isopods.....	138
Richarz, Professor, gravitation experiments of.....	205
Ridgway, Robert, bird collection from.....	58
Riker, A. L., automobile race by.....	596
Riley, J. H., collections by.....	59
Ritchev, Mr., nebule photographs by.....	156
Rivière, Emile, on pictures in grotto La Mouthé.....	439
Roberts-Austen, Sir W., researches by.....	177
Robinson, Wirt, animals obtained by.....	110
Röntgen rays, applications of.....	282
Dastre on.....	271-286
discovery of.....	740
due to vibration of atomic corpuscles.....	286
nature of.....	236, 282
penetrating power of.....	284
varieties of.....	284
vibratory, not emissions.....	283
Roosevelt, Theodore, member of Smithsonian Establishment.....	xi, 2
on forest destruction.....	401
on irrigation.....	412
on needs of Smithsonian Institution.....	145
Regent of the Institution.....	xii, 7
Root, Elihu, member of Smithsonian Establishment.....	xi, 2
Roscoe, Sir Henry, on Bunsen.....	133
Rotch, A. Lawrence, kite researches by.....	12, 133
on exploration of sea atmosphere by kites.....	245-249
Roth, Filibert, on forest destruction.....	402
Rothschild, Baron Edmund de.....	580
Rowland, Henry A., electrical researches by.....	742
heat researches by.....	743
life and work of.....	739-753
mechanical talent of.....	748
memorial address on.....	739-753
personality of.....	751
researches by.....	184
Rucker, Arthur W., model of nature by.....	171
Rumford, Count, quoted.....	178
researches by.....	174, 744
Russell, Frank, Indian studies by.....	67
Rust, Horatio N., collections from.....	55, 83
Rutherford, Lewis M.....	745

## S.

	Page
Sabine, Wallace C., sound investigations by.....	11
Safford, Lieut. W. E., on Abbott collection from Andaman Islands .....	475-492
Salt and its physiological uses, Dastre on.....	561-574
constituent of animal organisms.....	570
solution, life prolonged by.....	571
universal use as food.....	563
Salvation Army, farming colonies of.....	423
Santa Fe Palace, museum proposed at.....	27
Santa Lucia, sculptures of.....	132
Santos-Dumont, account of.....	585
balloon circling Eiffel tower.....	575-592
Saturn, rings of, nature of.....	175
Schaper, William A., paper by.....	140
Schmalensee, M., fossils collected by.....	59
Schuchert, Charles, fossils collected by.....	61
Schumann, Victor, researches by.....	12
Schuster, Professor, researches by.....	233
Science, Helmholtz on limitations of.....	190
Scientific literature, international catalogue of.....	xxi, 6, 23, 127
theory, Rucker on.....	172
Scollas, W. J., paper by.....	134
Scott, H. L., studies in philology by.....	78
Sculpture, ancient Cretan.....	433
Sea in life of nations.....	389-399
Sea lion, Dall on preservation of.....	687
Sea otter, Dall on preservation of.....	685
Seals of Northwest coast, Dall on.....	685
Seton, Ernest Thompson, on National Zoo.....	697-716
Seton-Karr, H. W., collection from.....	33, 57
Shambaugh, Benjamin F., paper by.....	140
Sharp, J. H., Indian portraits from.....	83
Shepherd, Sanger, on color photography.....	315
Shooting stars, meteorites and.....	195
Shufeldt, Miss M. A., collections from.....	56
Shufeldt, Robert W.....	56
Simplon tunnel, description of.....	626
Simpson, Charles Torrey, paper by.....	137
collections by.....	58, 61
Skinner, Professor, eclipse observations by.....	164
Slavery among Indians.....	74
Smith, Charles Emory, member of Smithsonian Establishment.....	xi, 2
Smith, Fred, minerals from.....	60
Smith, G. W. Duff Assheton, zoo of.....	691
Smith, James Walter, paper by.....	133
Smith, John B., paper by.....	137
Smithson bequest, amount of.....	xxv
Smithson's remains, question of removal of.....	xviii, 5
Smithsonian deposit in Library of Congress.....	xx, lvii, 22, 127
Smithsonian Establishment, members of.....	xi
Smithsonian fund, executive committee's report on.....	xxv-lvi
need of increase of.....	6
Secretary's statement concerning.....	xxiii, 8

	Page.
Smithsonian Institution compared with large universities .....	XXIII
finances of .....	XXV-LVI
future of .....	150
growth of .....	149
legislative history of .....	19, 129
organization of .....	146
President Roosevelt on .....	145
work and aims of .....	145
Smithsonian table at Naples .....	16
Snyder, John Otterbein, paper by .....	138
Sökeland, Herrman, paper by .....	135
Solar atmosphere, observations on .....	123
eclipse expedition of 1900 .....	44, 133
of 1901 to Sumatra .....	44, 124, 125, 161
energy, investigation of .....	266
engines, Thurston on .....	265
spectrum, Rowland's researches in .....	743
temperature and India rainfalls .....	133
Solid hydrogen, Dewar on .....	251-261
discovery of .....	251
nitrogen, Dewar on .....	252
Sound, articulate, Hallock's researches in .....	15
propagation and reflection of .....	14
researches in, by W. C. Sabine .....	11
waves, photography of .....	134
Sounds, vowel, analysis of .....	13
South American Indians, collections from .....	56
Spectra, stellar, Lockyer on .....	184
researches in .....	153
Spectrograph, Mills, work of .....	154
Spectroscope, stellar work with .....	154
Spectrum, Langley's work on .....	149
of Nova Persei .....	168
photographs of .....	744
photographs during solar eclipse .....	166
Rowland's researches in .....	743
the new, Langley on .....	135
Spectrum grating, Rowland's .....	743
Spencer, Herbert, quoted .....	634
Sprague, Joseph White, bequest of .....	xvi
Spurgeon, James R., Liberian eagle from .....	109
Standardizing bureau at Bushy Park .....	350
Stanley's African explorations .....	661
Starks, Edwin Chapin, paper by .....	139
Star spectra, Lockyer on .....	184
Stars, measure of heat of .....	157
velocities of, in line of sight .....	224
Steam engine, progress in .....	133
navigation, progress in .....	132
Steere, J. B., collections from .....	56, 60
Stegosaurs or plated lizards .....	646
Stein, Robert, Arctic researches by .....	68
Steiner, Roland, collections from .....	60



	Page.
Stejneger, Leonhard, papers by .....	138
Stellar motion, determination of .....	153
Kelvin on .....	225
Sternberg, George M., on malaria and yellow fever .....	135
Stevens, F. L., at Smithsonian Naples table .....	16
Stevenson, Matilda Coxe, on Indian ceremonies .....	81
Stewart, Alban, collections by .....	61
St. Gothard tunnel, description of .....	624
St. Louis Exposition, law providing .....	LXI
Stokes, Sir George, researches by .....	233
Stone implements, method of making .....	501-513
Stoney, George M., on Bogoslof volcano .....	371
Stoney, G. Johnstone, paper by .....	131
Strobel, Herman, paper by .....	132
Sturtevant, R. D., meteorite from .....	60
Submarine boat, Admiral Melville on .....	717-738
antidote to .....	727
compass unreliable on .....	723
construction simple in character .....	720
Dewey on value of .....	717
diving type of .....	721
endurance of crew on .....	721
France and the .....	728
Germany and .....	730
Great Britain and .....	729
Mahan on value of .....	721
Norway and .....	731
Russia and .....	730
submerged test of Fulton .....	722
the Lake design .....	734
value in warfare .....	717
value of torpedoes on .....	725
Sumatra eclipse expedition .....	45, 124, 125, 161
Sun, energy of, researches in .....	266
velocity of .....	225
Suns, number of .....	223
Sun's energy, utilization of, Thurston on .....	263-270
Sunlight, mechanical value of cubic kilometer of .....	216
Swanton, John R., Indian researches by .....	67, 79
Swastika, study of .....	68
Switzerland, exchange service with .....	91

## T.

Tablets, ancient Cretan .....	435
Tahiti, fire-walk ceremony in .....	539-544
Telegraph, instruments, collection of .....	57
ocean, Pupin system of .....	299
Telegraph or telephonograph .....	307
Telegraphy, wireless, Marconi on .....	287-298
trans-Atlantic .....	296
Telephoning, method of .....	300
trans-Atlantic, Anthony on .....	299-306
Telephonograph, W. J. Hammer on .....	307-312

	Page.
Temperature, air, investigation of .....	247
change in metal structure by .....	352
high, methods of measuring .....	355
in Alpine tunnels .....	623
low, Dewar's experiments in .....	251
of nebulae .....	243
rock, in St. Gothard tunnel .....	624
solar, and India rainfalls .....	133
Tennessee Centennial Exposition, report on .....	LXI
Topeka Indians, study of .....	37, 66
Termites or white ants, Haviland on .....	667-678
Terry, Seth Sprague, bequest to .....	XVI
Theatrephone, experiments with .....	311
Theories, physical, limits of .....	190
Theory, scientific, Rucker on .....	172
Thermometers, standardizing of .....	355
Thespesius, description of .....	646
Thomas, Cyrus, Indian studies by .....	78, 81
Thomas, Jessie E., on Maya language .....	79
Thompson-Seton, Ernest. ( <i>See</i> Seton.)	
Thomson, Elihu, paper by .....	131, 134
Thomson, J. J., on bodies smaller than atoms .....	231-234
on divisibility of atoms .....	184, 185
researches by .....	183, 272
Thurston, Robert H., on utilizing the sun's energy .....	263-270
paper by .....	133
Tidal power, utilization of .....	265
Tierra del Fuego during glacial epoch .....	383
Torpedo, Whitehead, value of .....	722
Traditional elements of primitive minds .....	458
Trans-Atlantic telephoning, Anthony on .....	299-306
wireless telegraphy .....	296
Traps, Indian, classification of .....	465
Mason on .....	461-473
Triceratops, skull of .....	644
True, Frederick W., exposition representative .....	26
report on biology by .....	136
Trumbull, James Hammond, Natick dictionary by .....	79
Tunnel, Babylonian .....	617
Mont Cenis .....	622
pool of Siloam .....	618
Simplon .....	626
St. Gothard .....	624
Tunnels, Alpine, temperature in .....	623, 624
ancient, account of .....	617
great Alpine .....	617-630
ventilation of .....	625

## U.

Ur of the Chaldees, excavation of .....	xx, 5
Utilization of Government Departments .....	4
Utilizing the sun's energy, Thurston on .....	263-270

## V.

	Page.
Vacua, high, methods of securing .....	259
Van der Waals, researches by.....	260
Van't Hoff, researches by.....	174
Variation of species, De Vries on.....	633
Varigny, Henry de, article by.....	135
Vaulx, Henry de la, of Aero Club .....	578
Velocities of stars, Kelvin on.....	223, 224
Very, F. W., on cheapest form of light .....	19, 129
Veth, Cornelius S., courtesies from .....	46, 124, 164
Vibrations, sympathetic, Rowland on.....	738
Vignaud, Henry, courtesies by .....	50
Villard, M., researches by .....	273
Vital force, nature of .....	189
Vogel, Professor, researches by.....	154
Volcano Krakatau, eruption of.....	163
Volcanoes, Bogoslof, Merriam on.....	367-375
Von Helmholtz, electrical researches by .....	740
Von Ihering, H., collections from .....	58
Von Lendenfeld, Dr., meteorological studies of.....	12
Vowel sounds, analysis of.....	13

## W.

Walcott, Charles D., fossils collected by .....	59
in charge of museum.....	XXII
on importance of irrigation .....	419
paper by.....	139
Walker, Gilbert T., on boomerangs.....	515-521
Walker, J. R., collections by.....	59
Walrus of northwest coast, Dall on .....	685
Wanderings of water buffalo .....	679-682
Ward, James, cited.....	181
Ward, Lester F., on petrified forests.....	131
War Department, courtesies by.....	163
Water buffalo, wanderings of.....	679-682
power of the world, extent of.....	263, 264
vapor, composition of .....	175
Weber, Rudolph, researches by .....	184
Webster, A. G., experiments in sound by.....	14
Weight of the earth .....	200
Welsbach Company, minerals from.....	60
Wesley, William, & Son, exchange agent .....	87
Westdahl, Ferdinand, Sitka deer from.....	109
White, Andrew D., Regent of the Institution .....	xii, 7
representative at Prussian Academy celebration.....	xvii, 4
White, Charles A., on mutation theory of De Vries.....	631-640
White, William H., paper by .....	132
White-tail deer, Seton on peculiarities of.....	703
Wild rice gatherers, study of.....	72
Wilkes exploring expedition, collections of .....	147
Willey, Day Allen, on Sokteik bridge .....	611-615
Willey, Henry H., plants from.....	58
Williams, Frederick Wells, paper by .....	135

	Page.
Williams, John C., courtesies by .....	87
Williston, S. W., on pterodactyls .....	657
Wilson, C. T. R., researches by .....	183, 233
Wilson, James, member of Smithsonian Establishment .....	XI, 2
Wilson, William Lyne, death of .....	XIII, 2
Henderson's tribute to .....	51
memorial resolutions for .....	XIII, 51
Smithsonian Regent .....	XII
successor to .....	XIV, LVII
Wind, observations of, in upper air .....	247
Wind power, utilization of .....	265
Winkler, Captain, paper by .....	132
Wireless telegraphy, across English Channel .....	293
coherer necessary for .....	288
in naval maneuvers .....	290
in South Africa .....	294
limits of .....	288
Marconi on .....	287-298
trans-Atlantic .....	296
Witt, discovered planet Eros .....	159
Wood, De Volson, on sun's energy .....	267
Wood, R. W., on photography of sound waves .....	134
Wood, T. I., collections by .....	58
World's Columbian Exposition, report on .....	LX
Writing, ancient Cretan .....	436
Wu Ting-fang, article by .....	20, 135
X.	
X-rays, Dastre on ( <i>see</i> Röntgen rays) .....	271-286
Y.	
Yaki Indians, ceremonies of .....	80
Yellow fever, transmitted by mosquitoes .....	135
Yellowstone Park, antelope in .....	705
Yerkes Observatory, photographs by .....	156
Yermak ice breaker .....	134
Z.	
Zeppelin's dirigible air ship .....	132, 133, 577
Zoological Park. ( <i>See</i> National Zoological Park).	
Zoo, National, Ernest Thompson Seton on .....	697-716
Zoos, private, Aflalo on .....	689















Smithsonian Institution

AUTHOR

Annual Report 1901

TITLE

SMITHSONIAN INSTITUTION LIBRARIES



3 9088 00944 9307