

Historic, Archive Document

Do not assume content reflects current scientific knowledge, policies, or practices.

GLEANINGS

IN BEE CULTURE



FIELD-MARSHAL
SELSE

THE A. I. ROOT CO.
MEDINA, OHIO.

Western Edition

Entered at the Postoffice, Medina, Ohio, as Second-class Matter

North Texas Beekeepers

will find Dallas the best point from which to purchase supplies. We have a carload of ROOT'S GOODS in stock, and sell them at Factory Prices. Don't forget that we can furnish anything in the way of field or garden seeds, plants, and poultry supplies. Large illustrated catalog for 1906 free on application. Mention *Gleanings* when you write. Wish to purchase Beeswax.

Texas
Seed and Floral Co.
Dallas, Tex.

SPRINGFIELD MISSOURI

We carry a
large and complete stock of

The ROOT'S 1906 BEE-SUPPLIES

All orders filled same day as received, thus insuring for our customers quick service, Springfield freight rates,

FACTORY PRICES

Send for seed catalog, bulb and plant catalog, Cyphers incubator catalog, The A. I. Root Co. bee-supply catalog

SPRINGFIELD SEED CO.
Springfield, Mo.

MR. TEXAS BEE-KEEPER

I would like to talk to you *personally*.

First, I want you to know about my supplies. I handle Root's Goods, of course; for I believe in giving my customers complete satisfaction—for that's *better* in the long run than low prices. My place of business is on the S. A. & A. P. Ry., just opposite the passenger depot, where I have built a warehouse 40×250 feet, and I have filled it full to the brim, for I handle Root's goods by the carload. This means I can furnish you supplies with the utmost promptness.

Then, too, I have installed a complete Weed-Process Foundation factory. I can turn out 500-lbs. a day. I can work your wax into foundation. In fact, my facilities in this line are not surpassed in Texas.

My can business is increasing by leaps and bounds. That is because of the quality of the goods. It will save you dollars to get my prices. Better write for them to-day.

Nothing pleases me better than for bee-keepers to make their headquarters at my office when at San Antonio. You are *always* welcome. I have fitted up my office with plenty of desks and chairs, with writing material, a reading-table, and all the bee journals on hand. Consider yourself invited.

If you haven't my catalog just drop a postal.

After the 15th or 20th of April I can supply Red-clover and Golden Italian queens promptly.

I am now paying 25c cash and 28c in trade for average clean beeswax delivered here. Save your slumgum. I will buy it. Let me know how much you have, in what condition the slumgum is, and in what kind of an extractor it was rendered, and I will make you price I am paying.

Call or Address

Udo Toepperwein - San Antonio, Texas

1322 South Flores Street

C. H. W. Weber,

Headquarters for

Bee - Supplies.

**Distributor of Root's Goods Exclusive-
ly, at Root's Factory Prices.**

Give me your order for the **BEST GOODS MADE**. You will be pleased on receipt of them. You will **SAVE MONEY** by ordering from me. My stock is complete; in fact, I keep **EVERY THING** the **BEE-KEEPER** needs. **CINCINNATI** is one of the best **SHIPPING-POINTS** in the Union, **PARTICULARLY IN THE SOUTH**, as all freight now **GOES THROUGH CINCINNATI**. Satisfaction guaranteed. Send for descriptive catalog and price list. It will be mailed you promptly **FREE** of charge.

I will buy your **HONEY AND BEESWAX**. I pay **CASH ON DELIVERY**; or, if you are in **NEED OF HONEY**, write for prices and state quantity wanted, and I will quote you the lowest price of any quantity wanted—in cans, barrel-lots, or car-lots—of **EXTRACTED** or **COMB HONEY**. I guarantee its purity.

QUEENS AND NUCLEI.

Let me book your order for queens. I breed the finest **GOLDEN ITALIANS**, **RED-CLOVERS**, **CARNIOLANS**, and **CAUCASIANS**. Can furnish **NUCLEI** beginning of June. For prices, refer to catalog, page 25.

I have in stock seeds of the following honey-plants: White and Yellow Sweet-scented Clover, Alfalfa, Alsike, Crimson Clover, Buckwheat, Phacelia, Rocky Mountain Bee-plant, and Catnip.

C. H. W. WEBER,

Office and Salesroom, 2146-2148 Central Ave.
Warehouse, Freeman and Central Avenue.

Cincinnati, - Ohio.

Honey Market.

GRADING-RULES.

FANCY.—All sections to be well filled, combs straight, firmly attached to all four sides, the combs unsoiled by travel-stain or otherwise; all the cells sealed except an occasional cell, the outside surface of the wood well scraped of propolis.

No. 1.—All sections well filled except the row of cells next to the wood; combs straight; one-eighth part of comb surface soiled, or the entire surface slightly soiled; the outside of the wood well scraped of propolis.

No. 2.—Three-fourths of the total surface must be filled and sealed.

No. 3.—Must weigh at least half as much as a full-weight section.

In addition to this the honey is to be classified according to color, using the terms white, amber, and dark; that is, there will be "Fancy White," "No. 1 Dark," etc.

MILWAUKEE.—The present indications are encouraging that the honey business will be good here, as the old crop stock is well out of sight, and the arrivals of the new crop, which we have received, are excellent in quality and condition, showing care in grading by the shipper, and careful handling, and will result in better returns, also attractive to the eye, which entices the taste of consumer; and we believe a more general use of the delightful and charming nectar by the people will result. We now quote fancy 1-lb. sections, 16 to 18 cts.; any grade below fancy white, 14 to 16 cts.; dark or off grades, 10 to 14 cts. Extracted, white, in barrels, pails, and cans, 7 to 8½ cts.; dark, 6 to 7½. Beeswax, July 29. A. V. BISHOP & Co., 119 Buffalo St., Milwaukee, Wis.

ST. LOUIS.—The honey market is practically in the same shape as reported last. There is some new comb arriving, and is quotable as follows; Fancy white comb, 15; No. 1, 14 to 14½; amber, 12½ to 13; extracted honey is slow at 6 to 6½ for light amber California, 1905 crop; Spanish needle is quotable at 6½ to 7 in 5-gallon cans; Southern new, 4½ to 4¾; for dark and inferior, less. Beeswax, for prime, 28½; all impure and inferior, less. July 20. R. HARTMANN & Co., St. Louis, Mo.

SCHENECTADY.—We have received two consignments of new honey. In one lot the combs are somewhat discolored, but quality is fair. Write for instructions before shipping, as some styles of sections do not sell well in our market, especially those weighing over a pound. We advise using shipping-crates, and sending by freight instead of express. July 18. C. MACCULLOCH, Schenectady, N. Y.

CINCINNATI.—We are having new comb honey arrive, and it finds ready sale, fancy white at 14½, and No. 1 at 13½. Extracted white clover in barrels, 7½; in cans, 8½; amber extracted, 5 to 5¼. Beeswax, 30. July 7. C. H. W. WEBER, 2146-8 Central Ave., Cincinnati, O.

TORONTO.—Inquiries for honey come in now every day; but honey is scarce, practically no new honey at all yet, and the prospect of having any quantity for some time is poor. Reports from most of that portion of the province of Ontario bordered by the great lakes would go to show that only a very light flow from clover, at least, can be expected; basswood and late flowers may improve the situation somewhat. However, the crop will not be very great this year. July 21. E. GRAINGER & Co., Toronto, Can.

DENVER.—To date but very little comb honey is in sight in this State. We have handled only a few small lots of new No. 1 white comb honey so far, which has brought \$3.40 per case of 24 sections. We could handle more to good advantage. We pay 24 cents for clean yellow beeswax delivered here. July 21. THE COLORADO HONEY-PRODUCERS' ASS'N., Denver, Colo.

PHILADELPHIA.—Advices from different points are rather conflicting regarding the honey crop this season, and, consequently, there is no market price established. Some new arrivals of comb honey sell at 13 to 15, according to quality, and extracted honey at 6 to 7. Beeswax firm, 28. We are producers of honey, and do not handle on commission. July 21. WM. A. SELSER, 10 Vine St., Philadelphia, Pa.

TOLEDO.—Market on comb honey at this writing is rather quiet, as people are waiting to see how the crop will turn out before making any stated market. Fancy white comb honey would bring 15 to 16 in the retail way; No. 1 at 4; extracted white clover and basswood in barrels would bring 6½, cans the same, possibly ½ ct. higher. Beeswax, 26 to 28. July 19. GRIGGS BROTHERS, Toledo, Ohio.

DETROIT.—No shipments of new honey in yet, and prices unsettled. Some offers are made, but no sales as yet. The impression seems to be among the buyers that the crop is large, and they want to buy very cheap. Nothing will probably be done for two or three weeks yet. Very little or no old honey in market. July 20. M. H. HUNT & SON, Bell Branch, Mich.

KANSAS CITY.—There is a fair demand here for fancy white comb honey in 24-section cases at \$3.00 to \$3.25 per case, according to quality; no new extracted in as yet, but some demand for the old at 5½ to 6. We look for prices to remain firm at about these figures, and think the demand will increase from now on. July 20. C. C. CLEMONS & Co., Kansas City, Mo.

ATLANTA.—On account of heavy fruit receipts, honey seems to have taken a place of secondary importance; however, we anticipate a reaction when the fruit season is over. We quote: Fancy white comb, 14 to 15; A No. 1, 12½ to 14; extracted, slow at any price. Beeswax, 28 to 30. July 12. JUDSON HEARD & Co., Atlanta, Ga.

STANDARD BRED QUEENS.

BUCKEYE STRAIN RED CLOVER, GOLDEN ITALIANS

By Return Mail. Safe Arrival Guaranteed.

	ONE	SIX	TWELVE
Untested	\$0.75	\$4.00	\$7.50
Select Untested	1.00	5.00	9.00
Tested	1.50	8.00	15.00
Select Tested	2.00	10.00	18.00
Select Breeders, each		\$3.00	
Two-frame Nucleus and Red Clover Queen		3.00	

THE FRED W. MUTH CO.,

No. 51 WALNUT ST., CINCINNATI, OHIO.

CHICAGO.—Not a very new comb on this market, and the old is used up so far as good grades are concerned. What the volume of sales will be on the new crop is problematical; but judging from the past it should sell in moderate quantities. R. A. BURNETT & Co.,
July 19. 199 South Water St., Chicago, Ill.

FOR SALE.—15,000 lbs. clover and raspberry honey in 60-lb. cans. Sample 5 cts.

JAMES MCNEIL, Hudson, N. Y.

FOR SALE.—3000 lbs very fine clover and basswood honey. Sample and prices free. Also 1000 lbs. white comb honey in 4¼x1½ plain sections

W. H. TOWNSEND, Hubbardston, Mich.

FOR SALE.—Superior grades of extracted honey for table use. Prices quoted on application. Sample, 10 cts. to pay for package and postage.

O. L. HERSHISER, 301 Huntington Av., Buffalo, N. Y.

FOR SALE.—Choice extracted clover honey. Extra choice, selected from all new combs, in round-jacketed five-gallon cans, for family use; \$5.00 per can. Prices on larger quantities in 60-lb. square cans, two cans in case, on application. Sample, 5 cts.

G. A. BLEECH, Jerome, Mich.

WANTED.—Fancy white comb and extracted honey. I pay cash—no commission.

WALTER S. POWDER, Indianapolis, Ind.

WANTED.—Comb, extracted honey, and beeswax. State price, kind, and quantity.

R. A. BURNETT,
199 South Water St., Chicago, Ill.

WANTED.—Fancy white comb honey, also extracted honey in barrels. Send samples, and name best price delivered here.

GRIGGS BROS., Toledo, Ohio.

WANTED.—Comb and extracted honey. State quality, quantity, and price.

JUDSON HEARD & Co., Atlanta, Ga.

WANTED.—Well-ripened extracted basswood and clover honey, light in color; prompt payment on receipt; 7¼ cts. per lb., f. o. b. West Bend.

H. C. AHLERS, West Bend, Wis.

WANTED.—Beeswax. Will pay spot cash and full market value for beeswax at any time of the year. Write us if you have any to dispose of.

HILDRETH & SEGELKEN,
265-267 Greenwich St., New York.

WANTED.—Beeswax. We are paying at this date for pure average beeswax delivered at Medina or any branch office named below, 27 cts. in cash or 30 cts. per lb. in exchange for bee-supplies, less transportation charges. We can not use old combs. Pack securely and address plainly. Be sure to send bill of lading when you make shipment. and advise us how much you send, net and gross weights. Ship to home office or nearest branch named below.

THE A. I. ROOT CO.,
Medina, Ohio.

Chicago, 144 East Erie St.; New York, 44 Vesey St.; Philadelphia, 10 Vine St.; Washington, 1100 Maryland Ave., S. W.

WANTED.—A case of two 60-lb. cans extracted honey (1906 crop) of each variety or source from every State in the U. S.; also from Canada, Mexico, West Indies, and other accessible countries. With each lot is required a certificate guaranteeing absolute purity of the honey, and gathered from the source named. Exceptional care must be taken to have the honey well ripened, of good representative color from source named. The honey should be extracted from clean new combs free from pollen. An extra price of about 2 cts. per pound will be paid for such honey, or we will arrange, if desired by any, to supply those co operating and furnishing sample shipments, with ¼-lb. samples of each variety secured, labeled with name of producer, year, and source of honey. We expect to secure at least sixty varieties of American and foreign honeys. Do not ship, but advise us what you can furnish, and on what basis.

THE A. I. ROOT CO., Medina, Ohio.

Chas. Israel & Brothers

486-490 Canal St., New York.

Wholesale Dealers and Commission Merchants in

Honey, Beeswax, Maple Sugar and Syrup, etc

Consignments Solicited. Established 1875.

The Danzenbaker Twentieth Century Smoker

Awarded Highest Prize
A GOLD MEDAL

at the World's Fair,
St. Louis, 1904.



UP-TO-DATE,
STRONGEST,
COOLEST,
CLEANEST.

It has a side grate that strengthens the fire-cup, and holds a removable metal and asbestos lining that keeps it cool, adding to its durability. It has no valves to get out of order or snout to clog.

Every Thing Guaranteed "Root Quality."

ALL THAT IS CLAIMED.—The General Manager of the National Bee-keepers' Association says:

I have given your Twentieth Century a thorough trial. For convenience in lighting, durability, and long time one filling will last and give ample smoke, I find it all you claim. In the spring I shall want several. I always want the best. N. E. FRANCE, Platteville, Wis.

SURPASSES ALL OTHERS.—"After giving the Danzenbaker Twentieth Century Smoker several trials, can say it surpasses all smokers it has been my liberty to try; it will not go out until fuel all consumed, and it produces a cool smoke, a feature very necessary in any first-class smoker." Grant Stanley, Nisbet, Pa.

Prices: By mail, \$1.25; three, \$3.25.

By express or freight, one, \$1.00; three, \$2.50.

For further particulars, see Dec. 15th Gleanings, pages 1870; sent free with price list.

F. DANZENBAKER, MIAMI, FLORIDA

Fruit Growers and Farmers.

Thousands of the best fruit-growers and farmers read the **Southern Fruit Grower** because they find it the most helpful fruit paper published. Contains 24 to 40 pages of valuable fruit and farming information every month. 50c a year. Send 10c and 10 names of fruit growers and get it 6 months on trial. Sample free. The Southern Fruit Grower, Box 1, Chattanooga, Tenn.

POULTRY DOLLARS COME EASY.

Our large 52 to 112 page beautifully illustrated magazine, best printed and edited poultry journal, makes it easy to add dollars to your income by keeping a few hens on a town lot or make a success on a large scale, covers every thing. Contains information that will put you in comfortable circumstances if followed. **POULTRY SUCCESS** one year, 50 cts. Large illustrated poultry book free to annual subscribers. Three months' trial, 10 cts. **POULTRY SUCCESS CO.**, Springfield, Ohio.

EVANS & TURNER,

Columbus, Ohio,

will be in the market for white comb honey, and especially want some fine stock from Wisconsin, Michigan, Indiana, and New York. They would also like to hear from Iowa producers. Write fully what you expect to have; and if you care to name price, do so, stating about what time your crop will be ready to move.

JELLY-TUMBLERS AT REDUCED PRICES.

You can double your money from your honey crop by using Jelly-Tumblers of correct style, as containers and keeping your market supplied. No other glass so economical. Write for quotations.

OREL L. HERSHISER,
301 Huntington Ave., Buffalo, N. Y.

Gleanings in Bee Culture

Devoted to Bees, Honey, and Home Interests

E. R. ROOT
Editor

A. I. ROOT
Editor Home Departments

H. H. ROOT
Asst. Editor

Department Editors:
DR. C. C. MILLER, J. A. GREEN, PROF. A. J. COOK, J. E. CRANE,
LOUIS H. SCHOLL, G. M. DOOLITTLE, W. P. ROOT.

J. T. CALVERT, Business Manager

A. L. BOYDEN, Advertising Manager

Circulation 30,000. Reaches every State and 60 foreign countries.
Established in 1873. Sixty-four pages. Semi-monthly.
Published by The A. I. Root Company, Medina, Ohio, U. S. A.

Terms---\$1.00 per annum; 2 years, \$1.50; 3 years, \$2.00; 5 years, \$3.00, in advance.

Postage is Prepaid by the publisher for all subscriptions in the United States, Hawaiian Islands, Philippine Islands, Guam, Porto Rico, Tutuila, Samoa, Shanghai, Canal Zone, Cuba, Canada, and Mexico. For all other countries in the Postal Union add 48 cents per year for postage.

Change of Address.—When a change of address is ordered, both the new and the old address must be given. The notice should be sent one week before the change is to take effect.

Discontinuances.—The journal is sent until orders are received for its discontinuance. We give notice just before the subscription expires, and further notice if the first is not heeded. Any subscriber whose subscription has expired, wishing his journal discontinued, will please drop us a card at once; otherwise we shall assume that he wishes his journal continued, and will pay for it soon. Any one who does not like this plan may have it stopped after the time paid for it by making his request when ordering.

How to Remit.—Remittances should be sent by Draft on New York, Express-order or Money-order, payable to order of THE A. I. ROOT COMPANY, MEDINA, OHIO. Currency should be sent by Registered Letter.

Agents.—Representatives are wanted in every city and town in the country. A liberal commission will be paid to such as engage with us. References required.

Foreign Subscription Agents

Foreign subscribers can save time and annoyance by placing their orders for GLEANINGS with any of the following authorized agents, at the prices shown:

Paris, France. E. BONDONNEAU, 142 Faubourg St. Denis. *Per year, postpaid, 5¼ fr.*

Kingston, Jamaica. HOOPER BROS., 20 Orange St. *Per year, postpaid, 5/6.*

Goodna, Queensland. H. L. JONES. Any Australian subscriber can order of Mr. Jones *Per year, postpaid, 5/6.*

Dunedin, New Zealand. ALLIANCE BOX CO., 24 Castle St. *Per year postpaid, 6/.*

Other names will be added from time to time.

THE A. I. ROOT CO., Medina, Ohio, Publisher.

Find enclosed.....for which please send me Gleanings in Bee Culture.....months, and.....as per offer..... Please continue sending Gleanings until otherwise ordered.

NAME.....

POSTOFFICE.....

COUNTY.....

STATE.....

DATE.....

If you want Gleanings discontinued at expiration, check here ()

FEEDING BACK

honey to secure the completion of unfinished sections can be made very profitable if rightly managed during the hot weather of July and August. In **ADVANCED BEE CULTURE** may be found complete instructions regarding the selection and preparation of colonies, preparation of the feed, manipulation necessary to secure the rapid capping of the combs, time for removing the honey, and how to manage if a few sections in a

case are not quite complete; in short, all of the kinks that have been learned from years of experience, and the feeding back of tons of honey. Remember, too, that this is only one chapter out of 33 treating as many vitally important phases of bee culture.
Price of the book, \$1.20; or the Review one year and the book for only \$2.00.
W. Z. HUTCHINSON, Flint, Michigan.

A READY POWER AT ANY HOUR

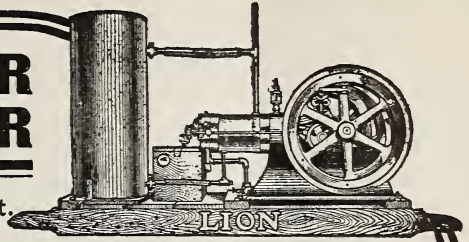

That's the kind of a power you want. You do not have to wait for steam, or until the wind blows, before you can pump water, grind feed, saw wood or the hundred and one other jobs about the farm, if you have a **Lion Gas or Gasoline Engine**. Have you ever thought just what a saving of time, labor and money it would be to have such a practical power **always ready to operate** your various machines on the farm, in the shop, printing-office, or—anywhere?

The LION Engine



is such a power. It is simple in construction, practical in operation, and economical in the use of fuel. You do not require the services of an engineer, as anyone can operate it. We send the **Lion engine**

Direct From The Factory

on a **ten days test trial** and give explicit instructions and directions for setting up and operating it. Write now, stating your power needs, for our easy payment plan. Remember, we send the **engine**, not the agent.

LYONS ENGINE CO., • • **Lyons, Mich.**

GOLDEN Opportunities!

EXIST in the South, and the Seaboard Air Line's monthly magazine will point them out to you. If you are thinking of changing your location, engaging in other business, want a winter home, a summer home, or a place for all-the-year-round residence, want an orange grove, a banana plantation, a pineapple grove—in fact, anything, and want it in Virginia, the Carolinas, Georgia, Alabama, or Florida, the magazine will assist you.

Sent free on request, together with other handsomely illustrated literature descriptive of the South and its wonderful resources and progress.

J. W. WHITE

Gen. Indus. Agt., Portsmouth, Va.

Seaboard Air Line Railway

Let Us Send You Our Book.

about good wheels and good wagons that will save you a lot of work and make you a lot of money—the

ELECTRIC STEEL WHEELS
—and the—
ELECTRIC HANDY WAGON.

By every test, they are the best. More than one and a quarter millions sold. Spokes united to the hub. Can't work loose. A set of our wheels will make your old wagon new. Catalogue free.

ELECTRIC WHEEL CO., Box 95 Quincy, Ills.

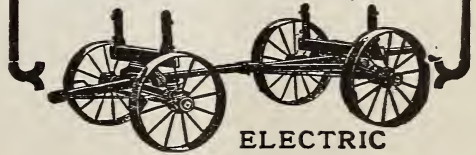

ELECTRIC



LAWN FENCE

Many designs. Cheap as wood. 32 page Catalogue free. Special Prices to Cemeteries and Churches. Address **COILED SPRING FENCE CO.,** Box 1443 Winchester, Ind.

CONTENTS OF THIS NUMBER.

MARKET QUOTATIONS.....	\$78	Wax-rendering Methods.....	1000
STRAY STRAWS.....	997	The Automobile for Out-apiary Work.....	1001
EDITORIAL.....	689	The Big Field Day at Jenkintown.....	1004
How to Move Bees a Short Distance.....	989	The Ferris System of Producing Comb Honey.....	1006
Sweet Clover.....	989	Bee-keeping in California.....	1007
What to Do if Foul or Black Brood Appears.....	989	Colony of Bees 60 feet from the Ground.....	1008
The Honey Crop this Season.....	990	Projections on Frames for Spacing Combs.....	1009
Robbing and its Consequences.....	990	HEADS OF GRAIN.....	1012
Red Clover as a Honey-plant.....	990	Combs that Have Been in Use 20 Years.....	1012
AMONG THE ROCKIES.....	991	Separating Queen-excluding Zinc from Top-bars.....	1012
CONVERSATIONS WITH DOOLITTLE.....	993	Comb Built over Wires without Starters.....	1012
GENERAL CORRESPONDENCE.....	994	Perpendicular Wiring Preferred.....	1013
Emptying Supers.....	992	The Alexander Treatment for Black Brood.....	1013
If I were to Start Anew.....	994	Letter from a Ten-year-old Bee-keeper.....	1013
Women and Bees.....	995	A YEAR'S WORK IN AN OUT-APIARY.....	1014
The Value of Double-walled Hives.....	997	HIGH-PRESSURE GARDENING.....	1015
Bee-hunting.....	998	OUR HOMES.....	1017
Extracting Honey Before it is Capped Over.....	999	SPECIAL NOTICES.....	1019

INDEX TO ADVERTISEMENTS.

Banking by Mail.	Colahan, F. J.....	1027	Honey-buyers.....	978
Savings Dep. Bank Co.....	Forehand, W. J.....	1029	See page.....	978
Bee-books.....	Jepson, H. H.....	1027	Household Specialties.....	
Hutchinson, W. Z.....	Koepfen, Chas.....	1028	Best Light Co.....	1032
Swarthmore.....	Lawmaster, L. A., & Sons.....	1027	Horne Co., Joseph.....	972
Bee Smokers.....	Lawrence, E. E.....	1028	Ulery Co., U. J.....	1032
Bingham, T. F.....	Laws, W. H.....	1027	Machinery.....	
Danzenbaker, F.....	Leininger, Fred.....	1029	Electric Wheel Co.....	981
Bee Supplies.....	Lockhart & Co., F. A.....	1026	Empire Mfg. Co.....	1032
Cook, J. H. M.....	Malan Brothers.....	1028	Lyons Engine Co.....	981
Falconer Mfg. Co., W. T., Back Cover	McCain, Robert B.....	1027	Myers & Bros., F. E.....	1032
Hershiser, Orel L.....	Mennie & Fenton.....	1029	Miscellaneous.....	
Hilton, Geo. E.....	Moore, J. P.....	1028	C., M., & St. P. Ry.....	1024
Hunt & Son, M. H.....	Mott, E. E.....	1025	Lester Co., F. E.....	1032
Jepson, H. H.....	Parker, Jr., H. M.....	1029	Prindle & Williamson.....	1032
Kretschmer Mfg. Co.....	Quirin the Queen-breeder.....	1021	Seaboard Air Line R. R.....	981
Lewis Co., G. B.....	Rails, W. H.....	1025	Stutzman, D.....	1032
Minnesota Bee Supply Co.....	Rambo, J. R.....	1028	T. T. Poultry Co.....	979
Muth Co., Fred W.....	Robey, L. H.....	1025	Publishers, Agricultural-paper.....	
Page & Lyon.....	Roselawn Apiary.....	1028	Southern Fruit Grower.....	979
Ponder, Walter S.....	Routzahn, G.....	1028	Publishers, Bee-Journal.....	
Prothero, Frank W.....	Shaffer, Henry.....	1028	Falconer Mfg. Co., W. T., Back Cover	981
Reeves, A. H.....	Shaw & Co., J. W. K.....	1028	Hutchinson, W. Z.....	981
Root Co., The, Syracuse, N. Y.....	Shuff, W. A.....	1029	Root Co., A. I.....	980
Root Co., The, St. Paul, Minn.....	Simmons, E. A.....	1028	York & Co., Geo. W.....	985
Scott & Co., C. M.....	Simpson, H. C.....	1027	Publishers, Poultry-paper.....	
Stringham, I. J.....	Strong, J. L.....	969	Ohio Poultry Journal.....	1032
Weber, C. H. W.....	Taylor, J. W.....	1028	Poultry Gazette, The.....	1032
Woodman Co., A. G.....	Titoff, A. E.....	1027	Poultry Item.....	1032
York Honey & Bee Supply Co.....	Victor-Knolle Apiary Co.....	1029	Poultry Success.....	979
Bees and Queens.....	Wurth, Daniel.....	1029	Wants and Exchanges.....	1038
Alley, H.....	Comb Foundation.....		See page.....	
Atchley Co., The Jennie.....	Dadant & Son.....	Back Cover		
Case, J. B.....	Dittmer, Gus.....	1021		
	Fences.....			
	Coiled Spring Fence Co.....	981, 1032		

ADVERTISING TALKS

BY THE AD. MAN.

GLEANINGS A SAFE AND SURE ROUTE.

So many of our friends have made the above statement when writing to us that we have chosen the title "THE BEE-LINE TO PROFIT" as the name of the GLEANINGS souvenir booklet which has just been issued.

This little book is quite the best literature we have ever gotten out to advertise GLEANINGS. It tells all about the days when GLEANINGS was a "beginner," and leads right down to the present time.

We should be very glad if we could afford to place a copy of this beautiful little book in the hands of every bee-keeper; but the expense of preparation and mailing forbids. However, we have set aside a generous number of copies which will be mailed, one copy at a time, to our friends. We hope that those who receive the booklet, and who are already subscribers, will use it to interest a fellow bee-keeper in this profitable way to successful bee-keeping. Address requests to the Ad. Man.

The A. I. Root Co., Medina, Ohio.

Dear Sirs:—That booklet, "Bee-line to Profit," is excellent and a beauty. After one reads it he sort of feels acquainted with GLEANINGS, and I feel sure much good will result. Very truly,

Indianapolis, Ind.

WALTER S. POWDER.

Great interest is being manifested in the GLEANINGS FAIR CONTEST, which is now on. When sending your name with the request that we enter you as a contestant, please be sure to give the name of the fair, and the date and place where it will be held. We want to secure absolute protection for our agents in their particular locality, and must have the information we ask for. Remember the prizes are cash, and that the regular cash commissions are also paid.

We have just printed a very neat 12-page illustrated price list of comb and extracted honey, for Messrs. J. E. Crane & Son, Middlebury, Vermont. We are very glad to see a honey-producer go after business in this really business-like way. We are sure that a great many bee-men would find it a profitable venture to follow the example set by Messrs. Crane. Should you be interested we will see that you get a copy of this price list if you will write.

HARVEST DAYS.

In August begin the days of harvest. Everywhere in agricultural communities grain is being garnered, and the farmer is figuring where he stands in this season's profits. He is, as it were, planning his next season's spending campaign. There is so much to be saved and so much for use in

supplying the wants of himself, his family, and his farm. Then this ought to be a good time to introduce yourself to the farmer if you have something which will make his work easier, more pleasant, or more profitable.

In the bee-keeping world, honey crops are coming in. In some localities crops are exceedingly good; in others, but normal. Whether the best or poor, the family needs and expenses go on.

This fall we shall introduce to our readers many new advertisers—new, perhaps, only to GLEANINGS. We shall, by admitting these advertisers to our columns, recommend them to the favor of our readers. Any advertiser who is acquainted with the personality of GLEANINGS IN BEE CULTURE realizes what this will mean. Do you wish to join the new comers, and reap a harvest to which your seed-sowing will entitle you? There is a word which we like—*seed-sowing*—that is what you do when you insert your advertisement in GLEANINGS, and we promise that, if you join us, we will do our best to prepare the field for your goods so that your returns will be fifty or one hundred fold.

The Francis E. Lester Co., Inc., Mesilla Park, New Mexico, whose advertisement appears on page 1032, are dealers in Mexican and Indian goods. There is one article which they handle very extensively, and which should especially appeal to bee-keepers; namely, a Mexican palmetto-fiber hat. These hats are the best kind we know of to wear in the apiary. The rim is broad, thus the veil is held away from the face; the hat is tough and everlasting. Another good point is that they are cheap. In the Lester Co.'s catalog we find a hat of the sombrero type—same as shown in the illustration in their advertisement—but without designed rim—priced as low as 40 cts. Other styles priced up to \$5.00. Mr. W. K. Morrison, one of GLEANINGS' correspondents, speaks very enthusiastically of the value of these closely woven hats in the bee-yard, and we would advise every one of our readers to send for a copy of this company's free catalog.

A letter illustrating the way in which GLEANINGS readers value the journal:

The A. I. Root Co.:—Please find order enclosed. I am very much pleased with GLEANINGS IN BEE CULTURE and could not afford to be without it. I find it up-to-date in every respect. I received A B C of Bee Culture, which is very interesting, and consider it a great work. I enjoy very much the articles by Mr. A. I. Root.

W. H. KNARR,
Manager Hawksworth Farm.

Greensburg, Pa., July 23.

A testimonial of the quality as well as the quantity of the results of GLEANINGS ad's:

The A. I. Root Co.:—Please discontinue our ad in GLEANINGS for help, as we have been almost flooded with applicants since the last issue. This certainly is a fine way to get good competent help.

Delanson, N. Y. E. W. & F. C. ALRXANDER.

Successful Bee-keepers

Use the best goods obtainable. This is the secret of the success of ROOT QUALITY. It has for its users more successful bee keepers than any other brand.

This extract from a letter we received from E. D. Townsend, Remus, Mich., who carries on the most extensive bee-keeping business in Michigan:

M. H. Hunt & Son, Gentlemen:—In thirty years Root's goods have been used almost exclusively in my yards with entire satisfaction.
Remus, Mich., July 7. E. D. TOWNSEND.

Again, a letter from a man whose experiments in non-swarmering, covering years of time, and costing many hundreds of dollars, have met with entire success:

M. H. Hunt & Son, Gentlemen:—The supplies purchased of you for twelve years have been the very best. As I produce comb honey exclusively, the sections and foundation have proven uniformly first class and are a guarantee for the future.
Your truly, L. A. ASPINWALL.
Jackson, Mich., July 9.

Again, from a young man who has built up a big apiary in a very few years:

M. H. Hunt & Son, Dear Sirs:—Please accept my thanks for the good quality of bee supplies sent me. The best is none too good. That is why I buy Root's goods. Have at present 280 colonies of bees.
Flint, Mich., July 10. LEONARD S. GRIGGS.

Join the ranks of the successful Michigan bee-keepers, and use Root's goods. We have the largest stock of supplies in Michigan, and can supply you promptly. Orders receive prompt attention.

M. H. Hunt & Son,
Bell Branch, Wayne Co., Mich.

A 30c "Trial Trip" The Balance of 1906

This Offer is Made Only to New Subscribers

to the **WEEKLY AMERICAN BEE JOURNAL**, and that means to those who have never read it regularly, or at least, have not had it during the past year or more. If you have been a subscriber at any time during the past 12 months we would not consider you a "new subscriber."

On this 30 cent "Trial Trip" offer, the sooner you order (sending 30c in stamps or silver), the more copies you will get for the money, for we begin to send as soon as we get your 30c.

No reader of **GLEANINGS** should be without the old **WEEKLY AMERICAN BEE JOURNAL**, now in its 46th year, and better and brighter than ever—so its oldest readers say.

A sample copy **FREE**. \$1.00 a year, or special trial-trip offer as above. Better order **NOW**, if you are not already a subscriber. Address

GEORGE W. YORK & CO.,

334 Dearborn St.,

CHICAGO, ILL.

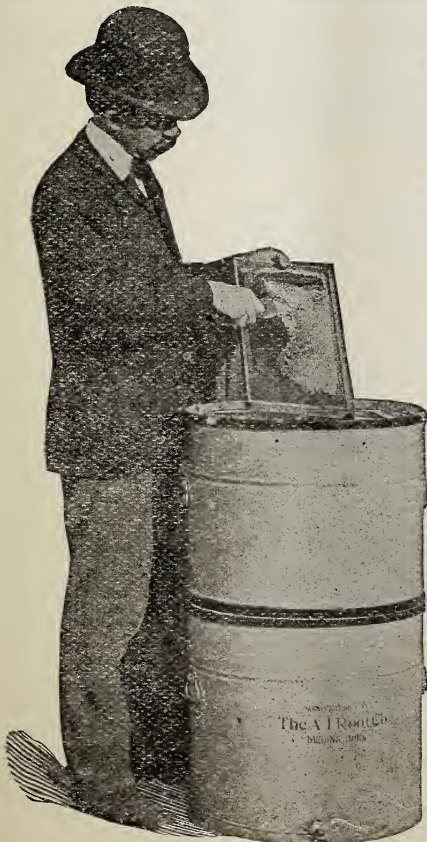

Mr. Bee-keeper

Just a minute of your time, please. Swarming will soon be over and honey coming in. We can send foundation and sections, if you need them, by express promptly.

The A. I. Root Company
Syracuse, New York

BE CAREFUL OF YOUR HONEY

Now that you have got to the shipping-point, be sure to see that your honey is properly packed in nice, white, smooth basswood cases accurately fitted, which adds dollars and cents to market price of your product.

Lewis Shipping-cases are the Finest in the World

Thousands of shipping-cases and millions of sections now ready for you in the warehouses of our selves and our agents as given below.

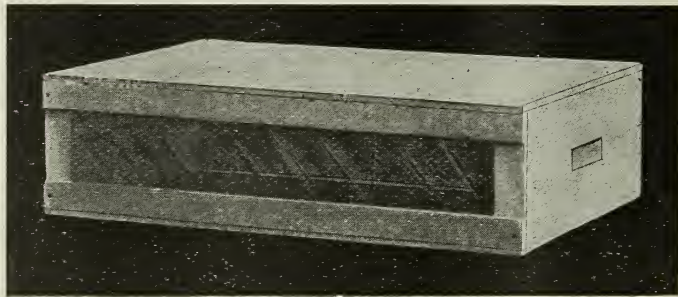

Beware where You Buy Your Beeware

ENGLAND—E. H. Taylor, Welwyn, Herts.
FRANCE—Raymond Gariel, 2 ter Quai de la
Megisserie, Paris.

CUBA—C. B. Stevens & Co., Havana.

C. B. Steven & Co., Manzanillo

CALIFORNIA—Chas. H. Lilly Co., San Francisco.

SOUTHERN CALIFORNIA.—

Fletcher-Doyle Co., San Diego.

Fallbrook Co-operative Association, Fallbrook.

Paul Bachert, Lancaster.

COLORADO—R. C. Aikin, Loveland.

Arkansas Valley Honey-producers' Ass'n, Rocky
Ford.

Colorado Honey-producers' Association, Denver.

Fruit Growers' Association, Grand Junction.

Robert Halley, Montrose.

IOWA—Adam A. Clark, LeMars.

Louis Hanssen's Son, Davenport.

ILLINOIS—York Honey & Bee Supply Co., 191-193

Superior St., Chicago.

Dadant & Son, Hamilton.

INDIANA—C. M. Scott & Co., Indianapolis.

MICHIGAN—A. G. Woodman Co., Grand Rapids.

MINNESOTA—Wisconsin Lumber Co., 432 Lumber

Exchange, Minneapolis

MISSOURI—E. T. Abbott, St. Joseph.

OHIO—Norris & Anspach, Kenton.

OREGON—The Chas. H. Lilly Co., Portland.

PENNSYLVANIA—Cleave & Green, Troy.

TEXAS—Southwestern Bee Co., San Antonio.

UTAH—Fred Foulger & Sons, Ogden.

WASHINGTON—The Chas. H. Lilly Co., Seattle.

G. B. LEWIS CO.

Manufacturers Bee-keepers' Supplies

WATERTOWN, WIS., U. S. A.

GLEANINGS IN BEE CULTURE

A Journal Devoted to Bees, Honey, and Home Interests
Illustrated : Semi-monthly : One Dollar per Year
Published by The A. I. Root Company, Medina, Ohio

Vol. XXXIV.

AUG. 1, 1906.

No 15

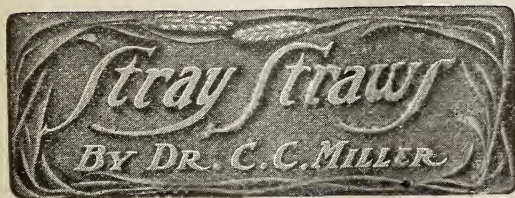

DR. MERRIAM, Chief of U. S. Bureau of Biological Survey, says skunks hunt mice and insects, and rarely kill poultry.

LAST YEAR 700,000 pounds of Canadian bluegrass seed was brought into this country, says government officials, and 250,000 pounds of yellow-trefoil seed, and all of it used to adulterate other seed.

SWEET CORN will lose, even in a cool place, and with the husks on, almost half of its sugar in 24 hours—the sugar, perhaps, converted into starch. So don't pluck your corn long before meal time.—*U. S. Report.*

JULIUS STEIGEL has been using metal combs 16 years, and has 1000 in use for extracting-combs. The cells are $\frac{3}{8}$ inch deep, and so they can not be used for brood, and no excluder is needed.—*Deutsche Imker aus Boehmen.* [I should like to know what those metal combs cost.—ED.]

P. NEUMANN mentions in *Leipz. Bztg.* that the Texas Bee-keepers' Association admits only whites, and wants to know whether all the larger bee keepers' associations of this country exclude colored people. I don't know. I never heard of any except the Texas association.

WONDERFUL ACCOUNTS are appearing of great yields of alfalfa over a large acreage near Fayetteville, N. Y. You know, Mr. Editor, that bee-keepers are not scarce in that vicinity. Can you get one of them to tell about alfalfa as a honey-plant there? [Alfalfa honey from York State is unknown.

I do not know of any place in the East where that plant has ever yielded any honey. I have never seen our bees go near our fields of it.—ED.]

A. C. ARMSTRONG doesn't approve of honey and cream on pancakes, page 948. I want cream on pancakes, or milk if I can't have cream, no matter what else is on them—helps their digestibility. Without it they pack into chunks of dough that the juices of the stomach can not easily penetrate.

TWO CASES of a person being stung by a queen are reported in *Deutsche Imker aus Boehmen.* In each case the pain was less severe than the average sting from a worker. A queen also in rare cases stings a worker. I saw one case, and never but one. A virgin stung a worker, killing it instantly.

KIDNEY DISEASE is alarmingly on the increase, says the U. S. Chemist. Extra work is put upon the kidneys by coal-tar dyes in butter, and preservatives in canned goods. Large quantities of sugar are injurious in the same way. Safety lies in substituting honey for sugar. [That is a good doctrine to preach; and it is true, every word of it.—ED.]

E. W. ALEXANDER says, page 935, "After you once get your colonies strong in bees, keep them so during the whole year." Don't you know, Mr. Alexander, that you are to have your bees strong for the harvest only, and not have a lot of useless consumers when there is nothing for them to do? Well, I don't know how it may be in other localities, but I never can get my bees strong too early in the season, and they never can be too strong to suit me afterward.

P. NEUMANN, in *Leipziger Bztg.*, gives a reason for a similarity of the contents of German bee-journals which is to the credit of German bee-keepers. It is the fact that each bee-keeper who is a member of the Central Bee-keepers' Association demands

that his journal shall give a report of the meetings of that association, and the number of members of that association is 50,000! That makes us Americans feel pretty small, Herr Neumann, with our big country and our little association of 2000 members.

MORLEY PETTIT says in *American Bee Journal* that the reason there are burr-combs between my top-bars, and none between his, is that my top-bars are $\frac{7}{8}$ thick and his $\frac{5}{8}$. If that's true I wish mine were all $\frac{5}{8}$. Does that same difference prevail in all other cases? [Mr. Pettit may be right; but my experience (as I now remember it) has been rather the other way. The nearer the comb comes to the top of the top-bar, the more of these brace-combs there will be. I should be glad to get reports on this question.—ED.]

REFORM of our abominable spelling is a thing that will not down. The papers say that simplified spelling is likely to obtain in the New York schools by adopting the spelling of the 300 words listed by the simplified-spelling board. But "shook" as a participle or adjective is not one of them. It is still spelled "s-h-a-k-e-n." [Now, doctor, I tried for nearly two years (just to please you) to get our correspondents to adopt the grammatical equivalent for "shook;" but they just wouldn't, and one fellow was mad, yes, *real* mad about it because we changed his copy.—ED.]

I DON'T KNOW whether buckwheat honey is more antiseptic than any other kind, as W. W. Case believes, p. 950; but I think it is a somewhat general belief. Why not decide by analysis the amount of formic acid in buckwheat as compared with other honey? [Buckwheat honey may be slightly more antiseptic than other honey, but I doubt it; but the point I desired to make was that a heavy flow from *any* source will *always* check and sometimes cure either black or foul brood. As buckwheat is a very strong yielder in New York, the honey would not have to be any more antiseptic than ordinary clover or basswood to account for the check or cure of the cases reported.—ED.]

J. L. ANDERSON'S plan of cleaning up sections isn't so simple as yours, Mr. Editor, p. 951, but it is a good deal safer. His sections will be all right, but yours will be torn to pieces. Didn't you mean to add that the entrance should be only large enough for one or two bees at a time? [In looking up page 951 I see I did not make it clear in the first part of the footnote that the sections I would put in the hive remote from the beeyard were to be first extracted; but in the next column, at the top of the page, you will see that I referred to the bees cleaning up the "wet sections." I do not think the bees would mutilate or tear down combs that have been uncapped and extracted. For such I wouldn't reduce the size of the entrance; but if not extracted I certainly would reduce the entrance to a space that would admit only one or two bees at a time. There, do we agree now?—ED.]

"Out of 119 counties in Kentucky, nearly 100 at the present time are under local option, and there is little doubt that a good many more will adopt local option under the County Unit Bill passed by the last legislature." That's not the jubilant note of a Prohibition paper, but the doleful wail of a leading liquor paper, Bonfort's *Semi-Monthly Wine and Spirit Circular*. Mind you, too, that's in Kentucky. [Of course, you do not mean that Kentucky in your last sentence is any worse than any other State, but that some other States have made greater pretensions, and yet are away behind on the temperance question. Another thing, Kentucky has a governor who is enforcing law. It is getting to be more the fashion nowadays to have governors who enforce law. With more good laws and governors who do things we shall soon drive out the rummies.—ED.]

YOU SAY, Mr. Editor, page 947, that you used the Jones nuclei back in 1882. Some years before that I saw Adam Grimm use them, and I don't know who used them before that. [It would not be at all surprising if Adam Grimm were ahead of all of us in the use of miniature nuclei; for it is a fact that this remarkable bee-keeper, who is said to have started a bank off from the money he made on his bees, was clear away and ahead of the times in several things. In speaking about the old Jones nuclei, one of our men brought in a day or two ago one of such boxes, made in 1878. It took five half Langstroth frames, or, rather, two frames made of such a size as would just fit inside of a regular standard all wood Langstroth frame, top-bar $\frac{3}{8}$ inch thick. When filled, these two half-sections filled were taken out and slipped into another frame just large enough to receive one. Five of these made up the Jones nucleus hive. A year or so later we got so far as to put a thin division in the center of these boxes, taking two nuclei of two frames each in one box. The general principle was practically the same as our twin nuclei of to-day, except that the latter divides the Langstroth frames up into thirds rather than halves.—ED.]

BY ALL MEANS, if we can, Mr. Editor, let's get to the bottom of that matter in last Straw, p. 929. Mr. Wardell says that, when a strange virgin gets into a hive, she almost invariably displaces the old queen. I *know* that the opposite is true here. It is not likely that locality has any thing to do with it. Is it character of bees, condition, or what? At one time I tried on a pretty large scale putting in very young virgins to supersede the laying queens. They were kindly treated while still young, but a day or two later they would turn up missing. If given to a colony about to supersede its queen the result no doubt would be different. Now I should like very much if you will tell me how to succeed as Mr. Wardell does. [In the foregoing, doctor, you have let out a fact that explains why your experience differs from ours. If you will refer back to a part of this discussion you will see that

we were talking about stray virgins just returning from their mating-trips making a mistake and going into the wrong hive. Such a queen will be in the height of her vigor; will be more agile—that is, more active—than a large laying queen in the height of her egg-laying capacity. Taking the case in point, she goes into the hive by mistake. She knows that, as soon as she gets into the hive, there is a laying queen there, and she makes for her. She is more than a match for her antagonist, and in the combat she usually comes out the victor. The colony accepts the situation, adopts its step-mother, and all goes well. In the same way, when we unite two nuclei, each with a laying queen, the stronger queen is the one accepted. Simmering it down into a nutshell, it is simply the survival of the fittest. Apparently you have been talking about a *young* virgin a day or two old that you let into the hive, and of course it is easy to see that such virgins will be no match for a laying queen; result, the interloper is dispatched nine times out of ten—perhaps always. Of course, young queens are usually kindly treated by the bees; but when the reigning queen discovers her rival, she gives her altogether different treatment. Mr. Wardell and myself would not disagree with you regarding treatment of young or caged virgins. But a queen from a mating-flight goes into the hive by mistake. She shows no fear because she goes where she supposes she belongs, and consequently she is treated well, although she may not have the colony odor. A caged virgin when released is a hard proposition, laying queen or not—ED.]



ANOTHER SPECIAL SERIES OF ARTICLES.

WE expect to have a special series of articles this fall on how to construct a beecellar. These will be from men who have made a success of the cellar-wintering problem, and who will be able at the same time to offer some good suggestions as to why some bee-keepers fail. About September there will be an article on how to winter bees successfully, buried in clamps. This will be followed by the special articles on indoor wintering.

NO CAUCASIANS FOR SALE.

WE keep getting calls for Caucasian queens. As before stated, we are not prepared to furnish them as yet. We are testing them quietly, to make sure that they have other desirable qualities than that of mere gentleness. We are rearing queens

from our imported stock in Florida, and expect to make a special yard of them a few miles from Medina, where they can not mix with our yellow strains.

HOW TO MOVE BEES A SHORT DISTANCE WITHOUT LOSS.

WE are often asked how to move bees a short distance, say a rod or two. We generally advise against doing this in the height of a honey-flow. One way is to carry the colony or colonies to an outyard and leave them there for about two weeks, then bring them back and place them at any point desired; and another way—one that we have been using with very good results—is to move the hive in the direction of its new location a foot or more every three or four days until the hive is at the desired point. This summer we rearranged a whole beeyard on this gradual-moving plan, and soon had them where we wanted them, without any loss of bees.

SWEET CLOVER.

SWEET clover seems to be unusually abundant in our locality, and early in the day it keeps our bees fairly busy. Unfortunately, under our Ohio law, road supervisors are ordered to cut down the sweet clover along the sides of the road, in the face of the fact that the plant will not grow on cultivated lands, and is the best thing in the world to preserve embankments on roads where it is so assiduously cut down.

It seems to me I saw a statement somewhere to the effect that a prominent railroad official stated that sweet clover was worth millions of dollars to the railroad companies. Its deep roots, and tendency to grow on banks or side hills, prevent millions of dollars' worth of earth from washing away on railroad embankments.

We bee keepers must get busy at the next session of our legislatures to get them to strike out from the present laws sweet clover as one of the noxious weeds. You can get the help of our experiment stations, and it will be nothing but pure unadulterated ignorance that will prevent the amendment to the laws.

WHAT TO DO IF FOUL OR BLACK BROOD KEEPS CROPPING OUT IN A BEE-YARD.

IN any yard where there is foul or black brood, especially if it has a tendency to crop out every now and then in other hives, it would be advisable to recomb every colony whether diseased or not. Combs melted up will about pay for new foundation.

Some years ago we had one yard where it seemed impossible to get foul brood out of it. We pursued the policy of giving foundation to all the colonies during the honey-flow, melting up the old ones, when, presto! the disease stopped instanter, and has been stopped ever since. In our home yard where we are raising bees and brood for sale, although we have no foul brood, and have not had any for years, we are pursuing the poli-

cy of recombining and subjecting the hive to hot steam every so often, merely as a precaution.

THE HONEY CROP THIS SEASON, AND PRICES, AGAIN.

THERE is very little to add to what has already been given, except to say that there will be some shrinkage from early estimates as to the amount of honey there would be from the Eastern States. It now begins to look as if the aggregate of comb and extracted honey for table purposes would be light. I see no reason why prices should not be as firm as last year at least.

A KINK WORTH KNOWING ABOUT ROBBING.

IF the apiary has been comparatively quiet, and no robbing, and the bees suddenly get into the honey-house, so that the room is fairly swarming with them, you will probably find it better and cheaper in the end to shut the door and brimstone all the bees in the room. Every one of these bees, if let out, will bring dozens and dozens more. It seems a pity to kill good bees; but the number will not begin to compensate for the demoralization of the whole yard, as these bees would do if let loose. If, however, robbing has been going on day after day, more or less, so that the whole apiary has been in an uproar, there will be no use in killing off bees in this way inside of a building. When robbers *first* start in the season is the time to kill them before they get away, if possible; and see that no further chance for other bees to get in to sip the stolen sweets is offered.

The principle in this case is a good deal like that of quelling a riot. The officers of the law know that the way to *cure* a riot is to stop it at the very inception—not to kill off the leaders, but to lock them up before they inflame the general populace.

ROBBING AND ITS CONSEQUENCES; PREVENTION BETTER THAN CURE.

ABOUT this time in most localities bees will be inclined to rob. Look out for exposed combs or sections of honey. They may be stored away in a honey-house provided it is absolutely bee-proof; but because of the fact that some one may leave the honey-house door open, and cheap labor is apt to do it sooner or later, I advise storing all combs of sealed stores, whether for the purpose of giving bees winter feed or for late extracting in hive-bodies or supers. If the bottom-board be removed, and the hive lies flat on the floor or on a flat board, it will be tight at the bottom. Several hives of supers may now be piled on top, each filled with combs. An ordinary cover may surmount the whole, but it would be better to shut it in with a wire screen, such as is used for moving bees. If the combs of honey are thus stored away, and the honey-house door should accidentally be left open, or the bees should perchance find a hole through

the walls of the building, no harm will be done.

In the same way, all open cans of feed or of honey should be protected by a cheesecloth covering that has an elastic band or rubber cord inserted in its edges so as to fit tight when stretched over the can.

RED CLOVER AS A HONEY-PLANT; A FEW INTERESTING FACTS.

THE article by Mr. Doolittle in his regular department, on this subject, is correct in every detail, from my experience and observation. He is exactly right when he says nearly all Italians will gather more honey from red clover some seasons than others; and he is equally correct, too, when he says the corolla tubes are shorter dry seasons (when the bees can work on them) and longer wet seasons. But our bees here at Medina (it may be the locality), while they will work on the plant better some seasons than others, work on it *every* season more or less.

RED CLOVER YIELDS MORE HONEY IN SOME LOCALITIES THAN IN OTHERS.

Another thing not mentioned by Mr. Doolittle is that red clover will yield more honey in some localities than others. In fact, in some places it doesn't yield at all. This is true of nearly all honey-plants, and especially of buckwheat. The soil in our locality has little or no sand in it. It makes the worst kind of mud and the most abominable roads in winter that can be found anywhere in the United States. While I do not claim that this soil is especially adapted to a rank growth of red clover (for I think the contrary is true), the corolla tubes, as Doolittle explains, are not so rank in growth, and consequently shorter.

Some years ago, when our bees were doing their best on red clover, I reported that the outer fringe of honey-tubes of these clover heads was shorter than those nearer the center. I was quite nonplused two or three years afterward to find that *all* the tubes were about the same length all over the heads. I had told our readers that the reason why Italians could gather honey from red clover was because there were some short corolla tubes on each head near the outer edges. Along about that time Prof. Gillette, of the Colorado Experiment Station, at Fort Collins, called my attention to the fact that it was not always true. I intended to make my acknowledgments at the time, and now do so with pleasure, since Mr. Doolittle has called the matter up.

A CASE IN POINT.

A little incident right here will serve to emphasize one or two facts that I have given. Our north yard, where we rear most of our red clover queens, has several fields of red clover adjoining it, for we furnished the farmers the seed of both red clover and alike free of charge. Well, when one of those farmers began to cut his red clover this season we came near having a bad sting-

ing-fracas; for when the cutter-knives of the mower went through the field they stirred up the bees, with the result that they attacked the horses, and the man on the mower. So greedily did the bees work on that field that it looked as though they were not going to let anybody cut off their honey-supply. I have heard since from other farmers in the vicinity that they had considerable trouble in cutting their red clover, because the heads were so covered with bees.

Now, *why* did the bees work on this red clover at our north yard when they did not pay any particular attention to the fields near by at Medina? Doolittle has given the key to the solution. Just two miles north of us there was almost a drouth during the latter part of the season, while at Medina we had plenty of rain, and also at our south yard. Just the other day I went over into a big field of rank clover at our south yard. I could scarcely find a bee on it, when quite the reverse had been true the whole season on the fields at the north yard, where there had been a drouth. The clover at the home and south yard by reason of the plentiful rains had attained a rank growth. The corolla tubes were so long that the bees couldn't get any nectar from them; consequently no bees on the heads.

with two exceptions. These are, the great number of weak colonies and the grasshoppers. Though the latter have as yet done little damage to the honey-plants, they are here in great numbers and we may hear from them yet.



CONTROL OF BEE-RANGE.

Australia takes the lead in a movement that is very important for bee-men by inaugurating the policy of leasing the exclusive right to a bee-range. While this is apparently only on crown (or government) land, it appears that this land is already leased for agricultural or other purposes, so there is a recognition of the principle that a man may have an exclusive legal right to the nectar on land that he does not occupy, and that the right does not come from the person occupying the land. This, in my opinion, is exceedingly important as a precedent. While the provisions of the act may not be in all respects satisfactory to the bee-keepers, it may prove to be the thin end of the wedge that will expand men's ideas on the subject until the government takes possession of all bee territory as something separate from the land, and leases or sells it by itself. Speed the day!



WEEDS AROUND THE ENTRANCE.

I would agree with Dr. Miller in saying that Doolittle put it a little too strong in saying that a growth of grass and weeds in front of the entrance might reduce the amount of honey stored to only two-thirds of what it might be with a free entrance. I think it would have to be pretty badly tangled indeed to reduce the yield very materially, merely as an obstruction to the flight of the bees; nor do I think that there would be a very serious wearing of wings unless the obstruction were very pronounced indeed. I keep the grass and weeds away from the entrances, partly because it looks better and partly because it makes my work with the bees easier. When I shake bees in front of the hive I want nothing to prevent their running right back into it. Otherwise knots of bees, especially the young ones, will gather on the weeds and sometimes do not readily find their way back. There is a much greater chance of losing queens at swarming time or when the bees are shaken from the brood-combs for any purpose. But as far as the bees are concerned, a moderate growth of weeds is very little obstruction, and may be of considerable benefit as a help in marking the entrance, as when a young queen is mated. A more serious objection to grass and weeds around a hive is that they shut off the circulation of air, and make the hive much hotter than where the air is not thus confined.



FOUL BROOD OR BLACK BROOD.

I have frequently felt puzzled at the claims made by the English writers on the subject of foul brood. So little did they

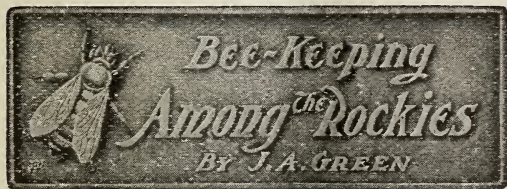

STOCK AND SWEET CLOVER.

After all that I have said about stock eating sweet clover, I must confess that there are times when they do not relish it, even if they have been accustomed to it earlier and liked it. It appears to become bitter at a certain stage in its growth, and they do not like it green, though it is all right made into hay.



SWEET CLOVER.

At the risk of being tiresome I want to say to you again that the only thing worth considering to plant for honey is sweet clover; and that for Colorado, or any locality where a yield two weeks earlier than that from white sweet clover would be of any importance, the yellow variety seems likely to be very valuable in connection with the white. See to it that you get some of it sown this fall.



THE HONEY CROP.

At this date, July 16, we are having a very good yield of honey from sweet clover. Alfalfa is just coming into bloom again, and the prospects for a honey crop are very good,

agree with my experience that I felt, as have many others, that they must have a milder form of the disease there. Various forms of cure by medication were heralded as successful, which proved to be utterly without avail here. It is true there was considerable looseness of expression indulged in. One writer, for instance, closed a long dissertation on foul brood by saying, "Of course by foul brood I mean all forms of diseased brood, such as chilled brood, starved brood, pickled brood, etc." I quote from memory, but I think I have his words. Nowhere in the article, except in this closing sentence, was there anything to indicate that he had any thing in mind except the genuine foul brood. But even among those who had the reputation of being careful and conservative, there was a difference between their claims and our experience that was not easily explained. The claims, for instance, that combs that have been thoroughly infected with foul brood may be cleaned out by the bees so that the disease will not reappear, and that Italians are more resistant to foul brood than other races, were not in accordance with the experience of practical men here.

The mystery seems to be in a fair way to be cleared up now. Our ideas in regard to foul brood have been based on Cheshire's theory that it was caused by a bacillus, *Bacillus alvei*, and we have retained this theory, although we have been compelled to discard his ideas in regard to cure. Now in the researches of the bacteriologists of the Department of Agriculture they have utterly failed to find *Bacillus alvei* in any case of foul brood, while they have found it in every case of what we know as black brood. It appears, then, that there are two brood diseases, and it is very probable that the English bee-keepers have either confounded the two or they have had no experience with the real virulent foul brood which has done so much damage here. I have before this called attention to the fact that the Cheshire theories did not correspond with observed facts, and the recent developments make it more than ever necessary for those whose apiaries are infected with foul brood to look with suspicion on all methods of cure by means of drugs or any treatment short of what has come to be known as the McEvoy method. This, which is really only a modification of the D. A. Jones method of cure, is based on the theory that the disease is usually conveyed through the medium of the honey, and that by compelling the bees of a diseased colony to consume all the honey they may carry with them from the diseased hive before any brood is reared they will be freed from the disease. No other cure has ever proven practical and effective.



EMPTYING SUPERS.

It has got now to the time of the year when some of us will be fortunate enough to have some supers to empty. Several have

told us how they go about this, but I do not remember that any one has given my method yet. It is very important that good methods be used, not only that time be not wasted, but that the honey be not damaged. I have seen even old bee-keepers remove the honey from the top of the super just as it came from the hive by prying out one or two the best way they could, then taking each section by the top and pulling it loose from the fastenings below by main strength. Small wonder that the sections pulled apart and that the honey leaked! A section is a frail affair, and it takes but very little to spring the sides of it enough to crack the comb and allow the honey to leak. The crack may not be perceptible to the eye, but the mischief has been done, and the salability and keeping qualities of the honey badly damaged. A section should never be pulled loose from its fastenings, but always carefully pried loose. Lay on the floor a cleated board with a smooth flat upper surface at least as large as the super. A hive-cover or floor-board may be all right for this. Scrape off all burr-combs from both top and bottom of the super, and lay it on this board, bottom up. Now lay on the super another cleated board of such size that it will just pass readily through the super shell, or outside. We will call this the follower. For the ordinary section-holder super or the T super with loose tins, a plain board, strongly cleated on one side, perfectly flat on the other, is all that is needed. For the T super with tins nailed fast, or any similar arrangement, you will have to build a follower that will allow the tins to pass through.

Now having your super upside down on the bearing-board, as I call the first cleated board I mentioned, with the follower on the super, flat side down, put your foot on the follower and push the whole inside of the super down on the bearing-board. If it does not start readily, put both feet on. Your whole weight will not hurt a section-holder super, though if you are a "heavy weight" it might be best not to get on a T super this way. After you get it started, lift off the super-shell, leaving the inside of the super on the bearing-board. Pick this up and put it on a bench at a convenient height to work at. Pry apart the section-holders. Pry off the separators, if they are loose, or pry them loose from the sections if they are nailed to the holders. Pry the bottom of the holder loose from the sections, and you can then remove the sections easily without danger of damaging them. In this work you should use a knife with a thin edge, and always insert it where the corners of the sections come together. It will not take as long to get the honey out of a super in this way as by the plan of tearing each section loose separately; and if you are careful, your honey is in far better condition than it often is by the rough-and-ready methods so often used; and if the honey is not broken in shipment there is none of the leakage that is so discouraging and disgusting to the retailer and consumer.



Conversations
with
Doolittle

HONEY FROM RED CLOVER, ETC.

"Hello, there! Is this Mr. Doolittle?"

"Yes, that is what they call me when I am at home."

"My name is Mills, and I want to talk with you a little about honey from red clover. I see by the papers that some claim that red clover is a honey-producer, while some of my neighbors tell me that the honey-bee does not work on this plant at all. Which is right?"

"Well, perhaps both, as they view it from different standpoints."

"How can that be?"

"Red clover is certainly a honey-producer. In fact, I believe that red clover gives more nectar than any other plant or tree that I know of, not excepting that famous honey-producer the basswood, or linden."

"That is saying a good deal, is it not? when I have heard of your saying that you had shaken honey out of the basswood blossoms on certain occasions."

"Yes, it is. But it is not often that you can shake the honey out from the basswood bloom, while I have yet to see the time when I could not find honey in the bloom of the red clover. In fact, I never pulled the blossoms from a head of red clover yet but there was honey or nectar in them in great profusion, no matter at what time of the year it was, nor what the season was; and the result is always the same, year after year; so I think that the question should be settled by this time by the fact that red clover always secretes nectar, or produces honey, if you please."

"Well, what am I to think of my neighbor's statement, then, if this be a fact?"

"This fact does not clash in the least with the statement of your neighbor, who claims that the honey-bee does not work on red clover. A plant may secrete honey profusely, and yet the blossom be so shaped that the honey-bee can not reach this nectar without the aid of something outside of itself to help it obtain the coveted sweet."

"Oh! I begin to see. But what is there to aid the bee in securing honey under such conditions?"

"I have often seen the wasps and hornets bite open the flowers of the comfrey, whose corolla is so shaped that neither they nor the bees can get at the nectar in these flowers, and after the holes were made in the flowers the honey-bees would swarm about these bitten flowers as long as they kept in bloom. And I have seen the same thing with the cup-shaped bloom of the common whitewood. However, the whitewood

would in time open so that both wasps and bees could obtain this nectar; but the wasps will not wait, so they tear open the blossoms at the side before they open, and in this way the season is prolonged to both parties."

"But neither wasps nor hornets work on red clover, do they?"

"Not that I know of."

"Explain, then."

"In certain seasons, and in some sections of our country, the corolla of the red clover grows so short, from drouth or otherwise, that the honey-bee can reach the nectar secreted by the blossoms, to a greater or less extent, in which case large yields of red-clover honey are obtained, as has been the case in this locality two or three times during the past thirty years. One year I obtained fully sixty pounds to the colony, on an average, of section honey from this source. In other seasons the secretion of nectar is fully as good as it was then; but, owing to the weather being favorable for a rank growth, the corolla was so long that the bees could not reach the nectar to any great extent."

"I see."

"Yes, and any person viewing the fields of red clover during one of these years of rank growth, which years greatly predominate, would be apt to decide that honey-bees never work on red clover."

"But does it not yield honey often enough so you can expect to secure good results from it?"

"As a whole we can hardly calculate on much honey from this plant, for there are far more years in which the bees obtain little or nothing from it than there are of those when the hives show a gain while it is in bloom, unless some other honey-producing flora is in bloom at the same time."

"But I see that some claim there is a difference in bees, some having long tongues, or those long enough so that they can reach the nectar in the clover, no matter how long the corollas are. These are styled red-clover bees, I believe. What do you think of these bees?"

"Well, the matter makes good advertising for a great many breeders of queens, although there is not quite the rage along that line that there was three or four years ago."

"Then you think such claims can not be substantiated?"

"I do not say that I think any thing wrong is intended, for it is expected that all know there are years when no honey-bee can secure any nectar to speak of from red clover. It is a fact that the Italian bees will reach this nectar within the red-clover blossoms when the black bees or hybrids do not do so; and from this has come the claim for red-clover bees; but, so far as I know, nearly all *Italian* bees are *red-clover* bees."

"Why do you say that?"

"Because I have had many different strains of Italian bees; and when it was a season that the bees could reach the nectar

in the red clover I could not see that any particular strain had the advantage over any other strain when at work on this plant."

"That seems strange."

"Don't misunderstand me. Some strains of Italian bees seem to work with a greater vim and energy at all times than do others, and these energetic bees will secure much better returns in honey from any and all sources than do the less energetic. What I wish to be understood as saying is that these energetic Italians do not show any special increase in yields over the others, while red clover is yielding honey, more than they show while white clover, basswood, or buckwheat is in bloom. They seem to be better bees at all times and under all conditions, often securing quite a little honey when the others are apparently doing nothing."

"I see. Will it not pay to breed from those showing the greatest energy, then?"

"Certainly. And that is just what our best breeders are and have been doing; so that to-day the standard of the Italian bees in this country is very much better during 1900 than it was during any part of 1800."

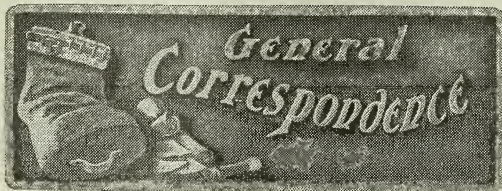

IF I WERE TO START ANEW, WHAT STYLE OF FRAMES, SUPERS, AND APPLIANCES WOULD I ADOPT?

In Favor of a Self-spacing Reversible Frame and 4x5 Sections.

BY E. W. ALEXANDER.

When Editor Root wrote me that he had chosen twelve honey-producers to discuss this question I at once thought that here will be a wide line of different ideas brought out; and, although I think so still, there is one thing of which I am sure—they will all do the same, and that is this: According to each one's experience they will give the readers of GLEANINGS a fair, unbiased, impartial opinion of this complicated question; and, since learning the names of my associates, I must say that, although I may stand alone on many points, I feel that it is an honor to be in their company.

If I were to start anew I would try hard to adopt some one of the standard hives already in use, mainly for this reason: If I wanted to sell my bees and appliances I could find a buyer easier, and sell at a much better price, than if my hives and appliances were of an odd size.

But, according to my ideas of a practicable all-purpose bee-hive, there are certain

things of paramount importance that would have to be embodied in it before I could in-dorse any hive to the extent of adoption. First, I should want a loose bottom—one that is not permanently fastened to the hive. Next, a telescope top. These are a great protection to the upper part of a hive from the summer heat and the cool weather of spring and fall; and they never blow off in bad storms, which is another good thing in their favor. Then I should want the frames self-spacing, so no two could ever, through carelessness, be crowded close together; and I would have them reversible, with some simple arrangement so there would be no special top or bottom. The size of the hive I should prefer would be equal to a nine or ten frame Langstroth.

In regard to the clamp for holding sections, and the size and shape of section, I think the Danzenbaker clamp-and-section arrangement for comb honey is far ahead of any other I have ever seen.

There, my friends, when you make a hive with all those requirements you will have, according to my idea, the best hive that has ever been devised.

Since I was invited to partake in this discussion I have spent some time in examining all the catalogs of different hives I could get, and I find that the Danzenbaker hive with its modern improved appliances has fewer faults and more advantages than any other hive I know of.

The hive we use for extracted honey suits us very well; and as we now have about 2100 just alike, it would seem foolish and be quite expensive to make them over into another kind of hive.

FACTORY VS. HOME-MADE HIVES.

In regard to which is the better and cheaper, all things considered, home-made or factory hives, I will say, don't be satisfied and contented with poorly made hives of any kind. I know of nothing more provoking than to have a lot of slam-bang hives. Bee-stings can not commence to make me feel as much provoked as to find some parts of a hive left a little too thick or too thin, too long or too short, to fit the place for which they were intended. If you are a good mechanic, and have a good planing-machine and all the necessary fine sharp saws to do good work, and can buy your lumber at a moderate price, then it is possible you might save a little in making your hives and appliances right through; but unless you are so situated I think it would be much better to buy all those things in the flat from some factory that does nice work. The one thing which is of far more importance than the first cost is to have every piece in a hive an *exact duplicate* of that part in every other hive. This is where factory hives usually have a great advantage over home-made ones. I have been fortunate in getting our hives and appliances without much trouble, always living as I have within a short drive of wood-working factories where I could either buy

the rough lumber or the hives ready to nail together, at a reasonable price.

Please do not infer from the above that I have not had any experience in cutting up lumber and making hives, for I certainly have had. Twice one hand has come in contact with the buzz-saw, to my sorrow. In going over this part of the business, it is not only the matter of hives but there are our sections, queen-excluders, separators, clamps for holding the sections in their place on the hives, crates for our comb honey—yes, even our queen-cages and labels, and, many times, our glass; for all these and many others we have to look to the large manufacturing plants. Now, why not go one step further, and, in sending in our orders, include the necessary hives, and have all come together in a good workman-like manner, even if it should cost a trifle more, which I have my doubts about, and then for many years enjoy the pleasure of knowing that you have all your bees in good well-made hives? This part is certainly well worth taking into consideration, for it instills in us a certain pride in our business which no man can expect to be successful without. Don't for a moment feel that any old ram-shackle thing is good enough for you and your bees, but make up your mind from the first that you will have every thing connected with your business just as good as any other man's, and then work hard to accomplish it.

Before I leave this subject I wish I could impress upon the minds of all those about to engage in bee keeping the importance—yes, I might almost say the necessity—of adopting some one of the standard hives as soon as possible. You must realize that you will have strong competition in the future in producing either comb or extracted honey, and it will be necessary to have the very best of every thing connected with the business in order to compete successfully with those who have these great improvements.

Delanson, N. Y.

WOMEN AND BEES.

Why they Should and Should Not Keep them.

BY ANNA BOTSFORD COMSTOCK.

[As promised in our last issue, we take special pleasure in placing before you this article by the lady whose portrait we presented on the front cover page of our July 15th issue. We have received a great many articles on bee-keeping for women, but never one that was more racy and readable than this. Like her book, it fairly sparkles with enthusiasm. Our readers, especially those of the feminine persuasion, should not fail to read it.—ED.]

Two questions invariably "pop up" at us when this matter of feminine bee keeping is discussed: One is, "Why shouldn't a woman keep bees?" and the other is, "Why should a woman keep bees?" Like most other questions these may be answered more or less rationally with proper consideration.

Taking the "why shouldn't" question first, we are bound to confess that nowa-

days there is no effective reason why a woman should not do almost anything that she takes into her enterprising little head to do. But quite aside from the consideration of woman's prowess, there are one or two reasons that might deter some of the faint-hearted fair from undertaking bee-keeping. There is no use of trying to gloss over the fact that there is a great deal of hard work and heavy lifting in the care of a profitable apiary. The hard work is really no objection, as most women of whatever class are at it any way. But lifting heavy hives is certainly not particularly good exercise for any woman, although I must confess that I have never lifted half so strenuously when caring for bees as I used to on the farm when we moved the cook-stove into the summer kitchen, accomplishing this feat by our feminine selves, rather than to bring to the surface any of the latent profanity which seems to be engendered in the masculine bosom when taking part in this seasonal hegira.

There are at least two ways of obviating this feminine disability in bee-keeping. One, practiced successfully by several women, is through the use of a Boardman hive-cart, which almost solves the problem if the bees are wintered out of doors, and do not have to be carried up and down cellar stairs; the other method is to get some man to do the lifting and carrying. It may be the husband, the father, the brother, the son, or the hired man; but as this work can be done at a time which can be planned for, it is not so difficult for the men of the establishment to give the help needed. I am sure my husband would say that I am quite enthusiastically in favor of the man solution of this problem; but his opinion does not count for much, because he loves the bees so enthusiastically that I have to beg for a chance to work with them at all, although he virtuously points out the hives to people as "Mrs. Comstock's bees."

Another "shouldn't" reason might be that women are afraid of bee-stings. This falls flat, from the fact that women are not a bit more nervous than men in this respect. This year when I was struggling to hive a swarm from a most difficult position, an interested man stood off at a safe distance in a most pained state of mind. He was a courteous gentleman, and he felt that it was outrageous for me to have to do the work alone, but he did not dare to come to my aid, and I think he considered my temerity in dealing with the swarm as almost scandalous.

Thus having disposed of all the reasons I can think of why women shouldn't keep bees, I turn gladly to the more interesting reasons of why she should look upon the apiary as one of her legitimate fields of labor. There are so many reasons for this that I could not enumerate them even if a complete number of "Bee Gleanings" were given me for the purpose. So I shall speak of just a few of the more cogent reasons. I should put first of all, and as embracing all

other reasons, that bee-keeping may be an interesting avocation which may be carried on coincidentally with other employment; it is an interesting study in natural history; it cultivates calmness in spirit; self control and patience; it is "a heap" of fun; incidentally it may supply the home table with a real luxury; and it may add a very considerable amount to the woman's spending money. It also may be carried on as a regular business and be made to support a family.

But it is as an avocation that I am especially interested in the apiary. Any woman who keeps house needs an avocation which shall take her mind and attention completely off her household cares at times. There is something about the daily routine of housekeeping that wears the mind and body full of ruts, even in the case of those who love to do housework better than anything else. Talk about the servant question! It is not the servant question, it is the housework question. If some means could be devised by which housework could be performed with inspiration, zeal, and enthusiasm, the servant problem would solve itself; but this ideal way of doing housework can be carried on only when the spirit is freed from the sense of eternal drudgery. I am not a wizard to bring about this change; but I know one step toward it, and that is the establishment of some permanent interest for woman that will pull her out of the ruts and give her body and mind a complete change and rest. Embroidery, lacemaking, weaving, painting, and several other like occupations, may serve this purpose in a measure, and perhaps if carried on in the right way might achieve more in this line than they do at present. But these are all indoor occupations; and what a woman needs is something to take her out of doors where she can have fresh air. The excess perspiration induced by the cook-stove is weakening; but the honest sweat called forth in the open air by an application of generous sunshine is a source of health and strength.

Bee-keeping is one of the best of these life-saving, nerve-healing avocations; it takes the mind from household cares as completely as would a trip to Europe, for one can not work with bees and think of anything else. Some of the attributes which make bee-keeping an interesting avocation I will mention: First of all, the bees are such wonderful little creatures, and so far beyond our comprehension, that they have for us always the fascination of an unsolved problem. I never pass our hives without mentally asking, "Well, you dear little rascals, what will you do next?" The bees are of particular interest to woman for several reasons: If she likes good housekeeping, then the bee is a model; if she likes a woman of business, again is the bee a shining light; if she is interested in the care of the young, then is the bee nurse an example of perfection; if she believes in the political rights of woman, she will find the highest feminine political wisdom in the

constitution of the bee commune. In fact, it is only as a wife that the bee is a little too casual to pose as an ideal, although as a widow she is certainly remarkable and perhaps even notorious.

Another phase which makes bee-keeping a pleasing avocation for women is that much of the work is interesting and attractive. I never sit down to the "job" of folding sections and putting in starters without experiencing joy at the prettiness of the work. And if there is any higher artistic happiness than comes from cleaning up a section holding a pound of well-capped amber honey and putting the same in a dainty carton for market, then I have never experienced it; and the making of pictures has been one of my regular vocations. By the way, woman has never used her artistic talent rightly in this matter of cartons. Each woman bee-keeper ought to make her own colored design for her carton, thus securing something so individual and attractive as to catch at once the eye of the consumer.

As a means of cultivating calmness, patience, and self-control the bee is a well-recognized factor. Bees can be, and often are, profoundly exasperating, and yet how worse than futile it is to evince that exasperation by word or movement. No creature reacts quicker against irritation than does the bee. She can not be kicked nor spanked; and if we smoke her too much, we ourselves are the losers. There is only one way to manage exasperation with bees, and that is to control it, and this makes the apiary a means of grace.

The money-making side of bee-keeping is a very important phase in arousing and continuing the woman's interest in her work. I think woman is by birth and training a natural gambler, and the uncertainties of the nectar supply and of the honey market add to rather than detract from her interest in her apiary. I know of several women who have made comfortable incomes and supported their families by bee-keeping; but, as yet, I think such instances are few; However, I believe there are a large number of women who have added a goodly sum yearly to their amount of spending money, and have found the work a joy instead of drudgery. Personally, I have had very little experience with the commercial side of bee-keeping. Once when our maddeningly successful apiary grew to forty hives when we did not want more than a dozen at most, and the neighborhood was surfeited with our bounty, we were "just naturally" obliged to sell honey. We enjoyed greatly getting the product ready for market, and were somehow surprised that so much fun could be turned into ready cash. As a matter of fact, both my husband and myself have absorbing vocations and avocations in plenty, so that our sole reason for keeping bees is just because we love the little creatures, and find them so interesting that we would not feel that home was really home without them; the sight of our busy little

co-workers adds daily to our psychic income. We are so very busy that we have very little time to spend with them, and we have finally formulated our ideals for our own bee-keeping, and that is to keep bees for honey and for "fun." We shall have plenty of honey for our own table, and just enough to bestow on the neighbors so they will not get tired of it; and fun enough to season life with an out-of-doors interest and the feeling that no summer day is likely to pass without a surprise.

THE VALUE OF DOUBLE-WALLED HIVES; PROTECTION FOR SUPERS.

Experience Proving that in Some "Localities,"
at Least, Such Protection is Necessary.

BY ADRIAN GETAZ.

In GLEANINGS for Dec. 1, 1905, the editor requests those who have had experience to report on the effects of protection or no protection to the hives—that is, for instance, the difference between double-walled and single-walled hives.

In my locality it makes a considerable difference throughout the whole season. In this latitude wintering is done out of doors. It would be difficult to have either cellar or special repositories in the ground cool enough through the whole winter to winter successfully.

Our winters consist of an alternation of bright warm spells of weather and cold, raw, rainy, or snowy days. During the warm days when the sun shines on the hives the bees are apt to come out in considerable numbers. Sometimes the air is yet too cold, and they are chilled before being able to get back. Others go too far in quest of pollen or nectar, and never return; so a large number are lost, and in some winters the colonies are reduced so much as to become nearly worthless. A doubled-walled packed hive will do away, at least nearly so, with that kind of mischief. The heat of the sun will not reach the bees at once, but be stored up in the packing, and reach them later and only gradually.

Another cause of loss is due to the brood-rearing that invariably takes place during the warm days. In single-walled hives a large portion of it gets chilled during the next cold spell, owing to the inability of the bees to cover all of it. In double-walled hives the loss is at least considerably reduced, though not always entirely. The double walls help the bees to keep the whole interior of the hive sufficiently warm.

After a favorable season the colonies go into winter quarters quite strong; and if the winter is open, quite an amount of brood will be raised. In fact, the colonies are frequently stronger in bees at the opening of fruit-blossoms than they were in the preceding fall. Under such circumstances they are often ready for the sections before the weather is warm enough. Then the protection to the supers is exceedingly valua-

ble. The colony with a protected super will go to work in it, while the one with an unprotected and too cold super will be unable to take possession of it, and then put all the honey possible in the brood-nest, sulk a week or two, and finally swarm. For me the protection of the supers has often made the whole difference between a crop of swarms and a crop of honey.

Perhaps some explanation on the "locality" should be made here. With you Northern people the spring does not come until the snow is all melted—that is, quite late in the season. At that time the days are long, the sun quite high, and the weather gets good and warm at once, and stays warm. In this latitude the case is different. The spring begins early, but drags along through a succession of warm and comparatively cold spells of weather. The maples begin to blossom irregularly in March, and sometimes as early as the middle of February, and the apple-trees about the 1st of April; but quite cold spells and frosts, and occasionally a regular freezing day, may come as late as the 20th of May. Under such circumstances the necessity of ample protection is seen at once.

Even during the summer the nights are often quite cool—in fact, cold enough to compel the bees to abandon the supers during at least the latter part of the night. It must be remembered that the summer nights are longer here than further north.

I began bee-keeping with single-walled hives. My work with the bees was done almost altogether at night, as another occupation was taking all my day time. One day, for some reason that I do not remember now, instead of going to the apiary after supper I waited until near daylight the next morning. When I opened the hives I found the supers empty of bees. Then, to use a rather slangy expression, I "saw a great light," and decided right there and then that henceforth the supers would be protected as well as the brood-nests through the entire season. That was sixteen or eighteen years ago.

Considering the fact that most of the honey-ripening and comb-building are done during the night, the importance of having them sufficiently protected is evident.

A single-walled hive exposed to the hot sun may be so warm during the day that the bees are compelled to quit work to a certain extent, and then when the night comes the radiation may be such that the supers become too cold for the work—a double loss. A proper shading would prevent the first trouble entirely, and the second to some extent. A double wall packed will not let the hive become too hot in the day, because it takes time for the heat to get through it. The packing will retain the heat and then keep the bees warm during the night. All this is, of course, a question of locality, or, rather, climate. Owing to the elevation above the sea, East Tennessee has cooler nights than the countries situated under the same latitude at a lower level.

THE HIVE.

My first attempt in that direction was to make what we might call a chaff-hive brood-nest with the outer walls extending above high enough to protect the supers. This did not work. With that arrangement it is necessary to put in and take the supers out at the top; and when they are propolized and fastened down well it is nearly impossible. Several times I had to take out all the sections in order to be able to pull out the supers. The next was to make the outer case protecting the supers independent of the brood-nest. For packing, there is nothing better than rags or old clothes. They can be put in and taken out rapidly without making a muss. The outer case furnishes a splendid place to put a feeder. It is left in winter with as much packing as is needed for protection. In very warm weather the packing is omitted.

That system works well, and it is very reluctantly that I am now giving it up. One objection to it is that it affords a too convenient place for the ants, roaches, and other "varmints." The other and most important one is the time it takes to take off the outer case and packing and put them back, especially to put them back, because the bees persist in getting in the way, and quite a bit of time has to be spent to get rid of them.

I finally decided on making the brood-nests, supers, and covers all double-walled and packed. I have tried different systems and sizes. For this locality a thickness of two inches of packing for the walls and three for the covers will meet all the requirements. Of course, it would not be enough for winter protection in more northern latitudes, but it is enough here. The lumber used is only half an inch thick. A single-walled hive must be made of lumber thick enough to keep the corners square; but a double-walled one is kept square by the strips at the top and bottom. With a light kind of packing and half-inch lumber walls a super is but little heavier than a single-walled one.

For packing I have used what I happen to have on hand; and when that was not enough I bought a bale of straw. Rags and newspaper crumpled up will do. I prefer straw, however, as it is light and warm. Perhaps excelsior might do as well. The planer shavings are too heavy—at least, those that I could get here. The forest leaves, apparently dry enough, contain too much dampness, and are liable to cause the walls to warp and pull out the nails. When they are really dry they are so brittle that they become unmanageable.

This construction has the advantage that hives, supers, and covers can be handled as easily and rapidly as single-walled ones, the only difference being in the weight; and, as above stated for the supers, it is not considerable. No preparation needs to be made for winter protection, shading, nor any thing. The objection is the cost, but, so far as I am concerned, I prefer to pay a

dollar or two more for a hive that is more suitable. It does not take long to make the extra cost back in increase of surplus and decrease of work. Remember that a hive lasts practically a lifetime.

Now that I have spoken for the best in my "locality," I should like to hear from others differently situated, and learn *why* their hives or management suits their *localities* best.

Knoxville, Tenn.

[Mr. Adrian Getaz is preaching good sound doctrine, not only for his own locality but for many others. We use double-walled or chaff hives in our bee-work at Medina. Our apiarists tell me that in the spring the double hives breed up very much faster; and when it comes hot summer weather they will stand the direct rays of the sun much better than the single-walled. Mr. Vernon Burt, our neighbor, has proved over and over again that an outer wall protecting a super when running for comb honey will give more and better honey than the unprotected supers. I should not be surprised if the day would come when the great majority of honey-producers in the region from the Ohio River northward, at least, will be using protecting-cases set down over the hive.

Mr. Getaz' observations in regard to the thickness of the lumber, and the general construction of the hive, are quite in line with our own practice. Years ago we made the upper part of the hive double-walled, but now make only the brood-nest double. The super has a telescope cap that rests down over it, which in our climate we find gives sufficient protection.—ED.]

BEE-HUNTING.

How to Get Bees and Honey out of Bee-trees
Without Cutting or Mutilating the Tree;
How to Get Bees out of Dwellings,
etc

BY RALPH P. FISHER.

Comprehending that the following experiences may not be new or undiscovered, the facts in the case are offered concerning the extracting of bees and honey from whatever abode they may have possessed as being surely profitable and very much easier than the many ways and means followed by the majority of the so-called bee and honey hunters. Those interested in the subject have no excuse to fail if the more important details of the system are followed out, and the minor duties fully tried in every particular. The succeeding statements are from actual experiences of a year ago, not to mention the cases successfully operated in seasons before, so it is hardly probable one can get much out of the way.

Bees are found in various places, in swamps or mountains alike, being either high or low as circumstances compel, the conditions causing the amount of trouble forthcoming in their extraction and capture. Then, again,

they may be in rocks, or lodged in a chimney, but invariably they will be found in a tree; and if it is a large swarm, with evidences of a large quantity of honey, the hunter's foremost desire is how to secure them with the least work and loss of time. Therefore, consider the case of five bee-trees having been located the fall before, and in the following spring upon examination each one is found to be worth the taking. Granted the hunter has bees at home in some kind of movable-frame hive, and that he is entirely familiar with every condition surrounding each location, he is ready to prepare the hives.

From a hive previously worked for the purpose, take all the frames and divide the bees and brood in five parts as nearly equal as possible, placing each part in a hive and filling the vacant space with full sheets of foundation or combs ready built, and then after introducing an Italian queen to each nucleus so made you may proceed to the trees. It is best to arrange the work so that it can be done in one day, which is generally possible.

Take with you all the necessary tools, etc., so that progress may not be hindered in substituting articles accidentally left at home. Some necessities are the nucleus, lumber for platforms, Porter bee escapes for each hole; nails, hatchet, saw, hand-lines, a good smoker—in fact, any little thing the mind of the hunter can imagine. The helper is needed, either sex; and after getting a position near the entrance to the wild-bee hive, adjust the escape so that all bees inside must pass out not to return. Then construct the platform so that, when the nucleus hive is set thereon, the entrance of it will face and be next to the exit of the escape. Now blow a blast or two of smoke in both entrances, and go on to the next tree, the whole operation not taking half an hour.

Having finished up the five trees and returned home, nothing remains to be done but to wait and consider, noting the progress at each tree. Imagine two queens laying for the building-up of one strong colony. Can anybody expect less than a very strong working force? After five or six weeks have elapsed it is time to be up and doing, for the queen in the tree has been through laying for twelve or fifteen days, there being an insufficient number of bees to care for the larvæ, as all the young bees have joined the colony on the outside.

Therefore, fire up the smoker, throw in a small handful of sulphur, pull off the escape, and apply the fumes vigorously through the hole, changing the air inside, leaving a dainty harvest for your swarm on the outside to rob out, which they will surely do in less than ten days. In fumigating, possibly it would be well to puncture the tree a time or two, near the top of the cavity, with an inch auger, and to add a super of sections or extracting-combs if the same hasn't been done previously.

After the robbing has ceased it is time to take them home, which is more or less hard

work. However, every thing is accomplished in a short time; and when fall comes around again one can hardly comprehend the little labor and time these trifling operations cost him.

But circumstances alter cases, and in the beginning one should become assured each colony so found fully warrants the undertaking, as it is known that some bee-trees never are strong in either bees or honey. Therefore consider well; and if it is decided the contents of the trees are worth the gathering, use this method and I'm sure pleasure and profit will crown your efforts.

To conclude, I will state that one swarm so taken and placed on a stand at home on the 10th of last July stored up almost forty Danzenbaker frames of honey, new and old, there being some frames not perfectly filled, although the results as a whole were perfectly satisfactory.

Great Meadows, N. J.

[Mr. Fisher answers a question that is propounded to us annually a good many times. I have always believed that the bees and honey could be taken out of a bee-tree or from between the walls of a house without cutting the tree or mutilating the house, in the manner that Mr. Fisher states. Accordingly two years ago I outlined a plan similar to the one here described. Never having tried it I was not entirely sure it would work out in all its details; but it appears that it does work, or at least Mr. Fisher says so. It will not be necessary hereafter to fell big trees or rip off the siding of a house or tear up the roof of a building to get at stray swarms of bees. The modern bee-escape, in connection with proper manipulation, will render this all unnecessary.]

I expect to incorporate this method of getting bees from bee-trees and buildings in the next edition of our A B C of Bee Culture, under the general head of "Bee-hunting," for there are times when the owner of the trees where the bees may be located would not allow his trees to be cut. Common law gives ownership to the man who first discovers the bees in a tree and marks the tree with his initials; but it does not give him the tree, nor permit him to cut the same without the consent of the owner of the tree. In no State, so far as I know, is there any special legislation covering this point; so that common law decides both the ownership of the tree and of the bees. — ED.]

EXTRACTING HONEY BEFORE IT IS CAPPED OVER.

What will this Practice Lead to?

BY ALPINE M'GREGOR.

I just wish to emphasize an editorial comment on Mr. E. W. Alexander's article, p. 153, Feb. 1. Referring to the advisability of allowing the extracting-combs to become fully capped before extracting, you say, "In

all the lake regions I am sure it is imperative." The "lake region," if I am correct, includes nearly all Canada except Manitoba and the Northwest, where, practically, there are no bees, and a part of the United States. I too am sure that it is imperative.

I remember very well when D. A. Jones was "King" in Canada. He practiced and advised extracting before the combs were capped, and ripening the honey in tanks holding about 375 lbs. All the bee-keepers with whom I was acquainted, and I think I may say the majority in Canada, followed this plan. The result was that the honey market for years was such that it was more difficult to sell the honey than to produce it. Many went out of the business; and those who remained, the writer among the number, decreased their stock. I will mention just one case in point.

A man, less than two miles from here, about twenty years ago extracted over 200 lbs. per colony. Being short of ripening-tanks he ran it into cans too soon; and the consequence was that every pound fermented, bulged out the cans, and forced itself out at the top. It was all sold within twelve miles from here, and I need not enlarge on the effect it had on the demand for honey in this "locality."

I will not say that good thick honey can not be produced by artificial ripening provided there is plenty of ripening-tank capacity and the weather is hot and dry; but take any one of the last three summers, last summer especially, when almost every second day there was rain, a damp atmosphere, cloudy and cool day and night—will any one say that honey could be properly ripened in such an atmosphere and at such a temperature?

About twenty years ago the writer was present at a convention in the City Hall, Toronto. The Rev. L. L. Langstroth, Mr. A. I. Root, Prof. Cook, Mr. D. A. Jones, and many other prominent bee-keepers from the United States and Canada were there. In the course of a discussion Prof. Cook arose and asserted, with all the dogmatism of a fifteenth-century Calvinist, that honey extracted before it is sealed and artificially ripened is just as good as that fully ripened in the hive. He had tested it—with some of his students I think he said—and they could not tell any difference. He further stated that we could not afford the time to let the honey ripen inside the hive. Mr. A. I. Root took the opposite view, and maintained that honey which is fully capped before extracting is superior—a position which I believe is endorsed by nine-tenths of the bee-keepers throughout the United States and Canada to-day.

Right here I may say that I do not consider an extracted-honey producer fully prepared for his business unless he has three supers for each colony of drawn combs. Thus equipped we can afford the time to allow our honey to become fully ripened in the hive.

I shall not presume to question the Alex-

ander method of extracting honey in *his* locality, especially *buckwheat* honey. I rather fancy that exposing it in large tanks for a week or so would improve it, as it might dissipate some of the aroma (?). But I do *not* want to see that system revived and re-introduced through the medium of GLEANINGS.

Inglewood, Ont., Can.

[As I have before stated, I will say again with further emphasis, that for the average bee-keeper, in the average locality, the combs should be fully capped before extracting. The extraordinary bee-keeper in an extraordinary locality may extract before capping.]

Prof. A. J. Cook is not now in this country or I would refer the paragraph in reference to extracting uncapped honey to him direct; but I may say this much: Since the time of the convention referred to, he has given out a statement that seems to be backed by facts and by scientific men generally, that the bees do something more than merely evaporate the nectar. They "invert" it, according to the chemists—or, as Prof. Cook prefers to put it, "digest" it, making a distinct chemical change between the nectar just as it comes from the flower and the honey from a fully capped comb. It is the opinion of the editor that Prof. Cook would *now* be among the number who would advise the average bee-keeper to let his combs become fully capped before extracting.—ED.]

WAX-RENDERING METHODS.

The Opinions of Some of the German Authorities.

BY F. GREINER.

Supplementary to my former article on rendering wax and the different methods employed by others I am to-day in a position to give you the opinion of noted bee-keepers in other lands, and their experience as well as their methods in regard to rendering wax, which may prove of interest to the readers of your journal.

Alfonsus, editor of *Bienenwater*, Austria, says: "After many unsuccessful trials to obtain the best and most wax from old combs, bee-keepers generally have returned to the old and tried methods of the heath bee-keepers and their wooden press. Hot-water wax-rendering machines are somewhat used, but not commonly accepted as the best. Steam wax-presses have outlived themselves."

Freudenstein, editor of the *Neue Bienenzeitung*, Germany, says: "According to my extensive experience, the steam wax-extractor is no good. The best thing we have is the Leipzig wax-press [a hot-water machine]. I am very well satisfied with it. The steam wax-extractor has been relegated to the lumber-room."

Prof. Luigi Sartori, one of the most noted bee-keepers in Italy, a man of wide experi-

ence, and a scientist, has nothing better to offer than the following: "Allow the broken-up comb to soak for eight or ten days. Then melt up with rainwater and cut straw, preferably rye. When good and hot, press with a good substantial wooden press. This method will give the best and most wax. Steam wax-extractors impair the quality of the resulting wax very materially."

Naples, N. Y.

[We are, and have been making some quite extended experiments on this wax rendering question, and will soon be able to give a report.—Ed.]

machine which opens up so as to carry four passengers.

Instead of paying a big price for this machine, our friend has been watching the markets until he found a bargain in a shopworn Pierce machine which he snapped up.

He finds that the automobile, while not an absolute necessity, is a very great convenience for the out-apiary. At Medina I should hardly know how to get along without one. While our bee-yards are located on a street-car line, yet the cars run only every hour. Sometimes I stay at a yard only ten minutes, and sometimes longer. As time is an important article I can finish up my busi-



DOOLITTLE ARRIVING HOME WITH A PART OF HIS OUT-APIARY COMB-HONEY CROP.

THE AUTOMOBILE FOR OUT-APIARY WORK.

BY E. R. ROOT.

The illustration above from a photograph shows Mr. Doolittle in his automobile, driving home with a load of comb honey from his outyard—or, rather, he has just arrived home with such a load.

In talking with friend D. at the Jenkin-town field-day meeting, he told me he found the automobile to be very convenient; would make quicker trips, and small loads he could handle very comfortably with careful driving. You will note he has a single-seated

ness with the boys, get back in a hurry, and if an emergency arises, as it did in one case where a neighbor's horses were stung slightly, I get down to the scene of action instanter. At one time a farmer at our Canine yard phoned that the bees were bothering his team while plowing. I jumped into my machine, arrived on the spot in a comparatively few minutes, found that the horses were working in the direct flight of the bees; found that the bees were not bad, but that the farmer was afraid *he* would be stung. I gave him a veil, and went home.

Second hand and shopworn automobiles are now being offered at a low price, and good ones too. I see some second-hand

Olds all the way from \$150 to \$250. Some of the latter are very good bargains. It often happens that a man buys a machine, gets tired of it, and offers it for sale at a great sacrifice. A good second-hand automobile will take care of a series of out-yards (provided a team be hired to do some heavy hauling in the fall and early spring), and it will be cheaper than a horse and buggy, if one takes into consideration the barn and the keep of the horse at a time when he is "eating his head off" and bringing in no returns.

The day is not far distant when the self-propelled vehicle will be used largely for out-apiary work. It will make trips in a third of the time; it can carry a considerable bulk of stuff, and be driven clear up among the bees, with never a fear of a fracas or a sting. Of course, there are tire expenses and repairs; but nearly every beekeeper, *if he is a successful one*, is a sort of genius any way, who, if he will read up, can make his own repairs, do his own adjusting, and then, when he is not busy with his bees,

get a world of comfort in drives with his wife and children.

Our little Olds, now in its fourth year, has traveled all over the country, has been used for running to outyards, and is still quite a snappy little machine. A machine just like it, and just as good, could probably be bought for \$200, and on our machine there must be several years of wear.

The repairs and tire expense will probably not exceed \$50 a year. After the first year one can keep this item down if he does his own repairing. When it comes to gasoline consumption the cost is far below the cost of oats, hay, and barn. A shed 8×10, and 6 feet in the clear, will house the machine, and at the same time hold gasoline and other supplies. On the other hand, if our bee-man does not love machinery and would never know when it is running wrong, or if he would run his machine over bumps and "thank you mams" at full speed, his repairs will be very large. Such a person had better never invest in an automobile unless he has a big bank account.



A. I. ROOT AT THE FIELD DAY TELLING OF HIS EXPERIENCE WITH CAUCASIANS IN FLORIDA JUST BEFORE HE BEGAN HIS DEMONSTRATION.



THE ROPED-OFF INCLOSURES WITH THE SIGNS IN THE FOREGROUND AS THEY APPEARED AT THE JENKINTOWN FIELD-DAY MEET BEFORE THE CROWD ASSEMBLED.

NOTE.—The initials "S. M." should be G. M. before Doolittle's name.

**THE BIG FIELD DAY AT JENKINTOWN,
JUNE 26, 1906.**

The Largest Gathering of Bee-keepers ever Assembled in the United States.

BY E. R. ROOT.

As previously announced, the big field day at the A. I. Root Co.'s exhibition apiary at Jenkintown, Pa., was more than a success. Indeed, the attendance was said to be phenomenal and the arrangements superb. As our Mr. Selser had expected, there were something over one thousand bee-keepers who were present at various times during the day and evening. Nearly 900 were actually fed by ticket at the noon hour. So perfect were the arrangements made by Mr. Selser, "field marshal of the day," that the nearly 900 were supplied with picnic rations inside of the small space of 38 minutes. Every thing else moved off in the same way.

The field day of a year ago had been such a complete success, at which something like 400 were present, that Mr. Selser, when the strong call came in for another meeting, was given carte-blanche instructions to go ahead at the expense of the Root Co., to issue the invitations, and] make all arrange-

ments for a big crowd who were to be the guests of the company at its exhibition apiary.

When we started out we did not expect that there would be a much larger attendance than we had the year before; but when the responses began to pour in, in answer to the invitations issued, it was apparent that there would be over 1000 bee-keepers present, and the estimates were fully confirmed by the actual attendance.

The field marshal, Mr. Selser, as shown by the front cover page of this issue, was dressed in white, and carried with him much of the time a speaking-trumpet, in order that he might announce to the crowds what demonstrations were to come off and when.

The day was all that could be desired. The day previous—in fact, for a whole week back—it had been raining and bad. But June 26 opened up, not with a bright sky, but with one darkened just enough by clouds to make it comfortable for the crowds out in the open.

The large illustration will show the various roped-off inclosures where the different speakers were to talk to their groups of bee keepers; for it must be explained there were several stunts going on at once. In order that each bee-keeper might hear each



MR. DOOLITTLE AT THE FIELD DAY ABOUT TO BEGIN HIS DEMONSTRATION.

[The Doolittle and Pratt work at the Field Day was performed on an elevated platform about four feet from the ground.—Ed.]



MR. DOOLITTLE AT THE FIELD DAY, DEMONSTRATING HOW HE MAKES HIS CELL CUPS,
AND HOW HE MOUNTS THEM ON CELL-BARS.

speaker, and take in just the class of demonstration work that he desired to see, conspicuous signs were posted up in the roped-off inclosures. Then Mr. Selser would from time to time announce with his speaking-trumpet that Mr. Doolittle would begin his work at his stand; Mr. Pratt at his; A. I. Root at his, and so on.

Prof. H. A. Surface, who was president of the day, presided over the large gathering that assembled in one big crowd under the shade-trees, backed by a sort of amphitheater arrangement of the grounds.

We had the pleasure of hearing several speakers, some of whom had not been previously announced, among them being the veteran bee-keeper, L. C. Root, of Stamford, Ct., a son-in-law of father Quinby. Mr. Root is a natural and easy speaker, and delighted the audience with some interesting reminiscences. Then several of the speakers were introduced before they actually began their work. This was followed by a demonstration by Prof. H. A. Surface, of Harrisburg, Pa., transferring from an old box hive to a modern one. The work was performed on an elevated stand in front of some seven or eight hundred bee-keepers.

There was not a demonstration that was more unique or better performed than this.

Prof. Surface has a clear voice, a forcible manner of delivery, and during the whole performance he held his audience with the closest of attention. As a college professor he knows thoroughly the art of teaching by object lesson. Many will wish to see and hear him again.

Unfortunately the editor's camera failed to get this transferring work, through an awkward mistake of leaving the cap over the lens while the exposures were being snapped off by the aforesaid editor, all oblivious to the fact that he was *not getting a single picture*.

You know there are certain times in one's life when he feels like turning around and kicking himself. Your editor had an acute attack of that feeling just about that time, but he refrained from inflicting the penalty.

The other illustrations here given show several of the speakers at work talking to interested groups while the demonstrations were being made. Among the number is A. I. Root, who, bareheaded, was explaining the qualities of some of his pet Caucasians. G. M. Doolittle was caught in several poses, for he illustrated his method of queen-rearing from start to finish, showing each step.

It is a matter of sincere regret that the whole GLEANINGS family was not able to hear Bro. Doolittle. He is a most interesting and forcible speaker, with a voice that can be plainly heard over a vast audience outdoors. His talks are always spiced with interesting anecdotes of the pure and wholesome sort that not only start a roar of laughter, but fasten indelibly on the mind of the hearer the truth that he is teaching. Those who heard him get off some of his good stories at the Buffalo National convention a few years ago will remember that he was the uncrowned king of that convention; for repeatedly did the members try to make him President — an honor which he as often gracefully but firmly refused.

There was one demonstration that we did not make that day, nor did any one volunteer his services; and that was the handling of a colony of Cyprian bees. As it was, we put a big placard in front of the one hive of them, announcing "danger," as will be seen by one of the illustrations herewith given. While the crowds freely assembled around the hive they seemed to have a wholesome respect for the bees.

In our next issue, and perhaps the one following, we will give other snap-shots of this Jenkintown meeting, the like of which was never held before in the United States; and, as Prof. Surface said, it was the largest, as well as the most notable, gathering of bee-keepers that was ever held in the United States in one place. Others asserted it was the largest ever held in the world. While this may be true, the editor has some doubts about it.

Continued in our next.

THE FERRIS SYSTEM OF PRODUCING COMB HONEY, AND SWARM CONTROL.

Conditions that Lead to Swarming; Comb-honey Supers Constructed Wrong.

BY A. K. FERRIS.

When I think over the different makes of supers I do not wonder that people go home scratching their heads and lie awake nights trying to plan something to prevent or control swarming. In the first place, nearly all supers are put up on a wrong principle. We



"HEY, THERE, MR. MAN! WHAT YOU DOING? DON'T ALLOW THAT. COME OFF THE ROOF."

[Dr. Lyon was on the roof of the honey-house poisoning the tripod of his 8x10 camera when Mr. Doolittle caught him in the act. His abrupt interjection at the moment so scared the camerist that he nearly fell "off the roof." But Doolittle didn't know that ye editor with *his* camera had elbowed his way through the crowd and snapped it at him, just at the moment he was ordering the other camera fiend off. The smiles of the people opposite show something of Dr. Lyon's surprise, not to say consternation.—Ed.]



ONE OF THE ROPED-OFF INCLOSURES (AFTER THE CROWD LEFT) AT OUR JENKINTOWN YARD. THE ONE HERE SHOWN WAS USED BY GRANT STANLEY.

have attempted to get the bees to build comb and store honey where they do not like to. Bees like to store honey by the side of and near their brood.

But right here I hear some one say, "There are difficulties which arise with the use of brood."

Yes, that is all true; *but all these difficulties can be, and are, turned to our favor*—

1. By the use of drone comb in the sections the exclusion of pollen is effected; and, 2, by the use of frames of foundation in securing brood to be used with the comb-honey attachment, you avoid darkened combs in the sections. In this you have eliminated the two great difficulties; viz., soiling of the comb honey by dark combs of brood, and excluded the pollen from sections, and also gained a point; for when bees are strong they like to build drone comb when honey is coming in. This gives the bees a chance to build just what they like to, and serves to keep them more contented—a factor too often overlooked in control of swarming.

Thus by having all worker comb below the excluder, and drone comb in the sections, you have excluded the pollen, made your bees take to the super more readily, and this goes a long way toward getting more honey, and, consequently, more money.

Mr. L. A. Aspinwall, in the *Bee-keepers' Review* for March, 1906, has truly said that, "In prevention of swarming we must prevent a development of the factors which induce it. These hinge mainly on a crowded condition of the colony. This condition results in the clogging of the brood-apartment with honey, and impeding the queen in her work of laying." Mr. Aspinwall relieves this condition largely by the use of slatted frames and plenty of room. This will in most cases prevent swarming; but I prefer to accomplish this same result in a more

practical way and at less expense. Instead of using slatted frames for the bees to cluster in I induce them to enter the super and spend their time in drawing out comb. In this way I have accomplished a double object as you will notice, by the use of what I call a "comb-honey attachment."

With brood by the side of the sections, the nurse-bees and comb-builders, which are the young and hatching bees, are drawn into the super by the most powerful inducement, and they are kept there busy building comb. This is one way in which the shook-swarm system fails. They have to take bees, that otherwise would be gathering honey, to do the work of comb-building and nursing.

By using two queens until the flow begins, and only one after, we have less brood reared through the flow; still, there is enough hatching all the while to furnish nurse-bees and comb-builders, so that, just as soon as the bees are old enough, they are at liberty to enter the field for honey. On the other hand, comb is constructed so rapidly, where full sheets of foundation are used in the sections, that the same amount of honey is produced as would be if the hive were run exclusively for extracted; yet from 50 to 75 per cent is comb and therefore brings a much higher price.

.....
BEE-KEEPING IN CALIFORNIA.

Some of the Sources of the Light and Dark Honey.

BY FRANCIS J. COLAHAN.

Perhaps it may be of interest to your readers to know something in regard to the conditions here in this section. As all know, the main crop and the best is sage, black and white; but there is as much honey gath-

ered from wild buckwheat and sumac as there is from sage. Usually it is about an equal amount, so that, when the sage is in, it is a safe matter to order an equal number of cases for the wild-buckwheat and sumac honey. The buckwheat and sumac honey is gathered at the same time, the bloom starting at about the time the sage is going out. The bees, however, will usually work on the sage as long as they can get it. That is one of the best tests of the working qualities of different varieties of bees here. Let me explain here what this test is so you will understand clearly.

Almost all apiaries in this section are situated in the mountains, and the flowers bloom first in the valleys; and as the season



THE COLONY WE DIDN'T "DEMONSTRATE" AT THE FIELD DAY AT JENKINTOWN: THE "Z Z" STANDS FOR "ZIP, ZIP, STING—GET OUT!"

advances the blooming-belt gradually passes up the mountains and away from the lower ground. The apiaries are usually situated at the base of the hills; and as the season advances the bloom recedes. Now, there is no better judge of fine honey than the bees. They will gather the lightest honey they can find. Here is the point in determining the best bees. While the sage is blooming near the apiary, all the hives will have sage honey; but as the sage bloom gradually recedes, some of the bees will stop bringing in from

the sage and start on the sumac. They are like a great many people—they take that which is the easiest to get, regardless of quality. The others, which bring in the sage the longest, are invariably the best colonies.

The season this year opened better than it has for years; but the promise did not hold good. The early rains of November were followed by severe frosts which killed the bloom of the manzanita and the old-man sage. This was rather bad, as last year the manzanita did not yield honey on account of the severe drouth. In good years the bees bring in and cap quite an amount of surplus, which is a great help in brood-rearing later on. We count on the manzanita bloom to start brood-rearing, and the bloom invariably comes just one month after the first heavy rain of the season.

The "shooting stars" are blooming (pollen); also the oak, the willow, and some varieties of the eucalyptus, while a few early blooms of the alfileria are to be seen out here and there.

Before closing I wish to speak of the dodder. In one of Prof. Cook's articles he says the best way to get rid of the plant is to burn the hills clear of brush. It does not work in practice. A year ago last October we had through here a wild fire that swept the hills clean and bare, not leaving a single bush. While passing through a portion of this burnt district I was surprised to see quite a good deal of the dodder growing at least a mile from the edge of the fire-swept district. I have seen it in half a dozen different places since, all where the fire had burned. The bee-feed will not be as good in the district for three or four years, and fire did not kill the dodder; so Prof. Cook's advice to burn off the hills does not answer its purpose.

Bernardo, Cal., Jan. 30.

A COLONY OF BEES LIVING OUTDOORS 60 FEET FROM THE GROUND.

I have noticed that you wish reports from any one who knew of a swarm of bees located outside on the limb of a tree. I took down one such that was at least 60 feet high, on a limb about six inches through. It had made five combs at least $1\frac{1}{2}$ feet long by the same in depth. We cut the limb off at the outer end past the bees, and let it fall to the ground. Then we sawed the limb off close to the bees next to the tree, and let it to the ground with a rope. This was late in November. Bees were first discovered in July. One noticeable feature showing bee wisdom in this hive was that the two outside combs were made with the outside cells protruding downward to protect them from the rain. I left them on the limb and incased them in a box, and up to date they are all right, and I am sure they have plenty to do until they can make more. If not, I shall feed them.

GEORGE W. RICH.

Trezevant, Tenn.

PROJECTIONS ON FRAMES VS. NOTCHES IN RABBETS FOR SPACING COMBS.

A Discussion of the Merits of the Notched Rabbets; Metal Frame-spacers; Views of some Different Foreign Styles.

BY L. STACHELHAUSEN.

[Mr. L. Stachelhausen, a native of Germany, has, ever since he came to this country, been keeping in close touch with all that has been going on in the fatherland. Knowing that he is familiar with the frame-spacer question as it has been tested in his own country, we requested him to write an article on the subject. In doing so he sent along a large number of prints of various frame-spacing devices from the German catalogs and journals. These we have redrawn and reengraved, and place the same before our readers without any attempt at classifying or naming them. Any practical man familiar with the frame-spacer question will at once see how these devices are applied, either at the top or bottom of the frame. Our correspondent's article will be read with unusual interest.—Ed.]

Mr. Root:—Last year we had some correspondence about the merits or demerits of Hoffman frames compared with a spacing-device on the rabbet. As you have devised a very nice metal spacer I see you are trying to overcome some of the difficulties with the Hoffman frame. This means you concede some of them at least. As I still think you are on the wrong track I will again explain my position on this question.

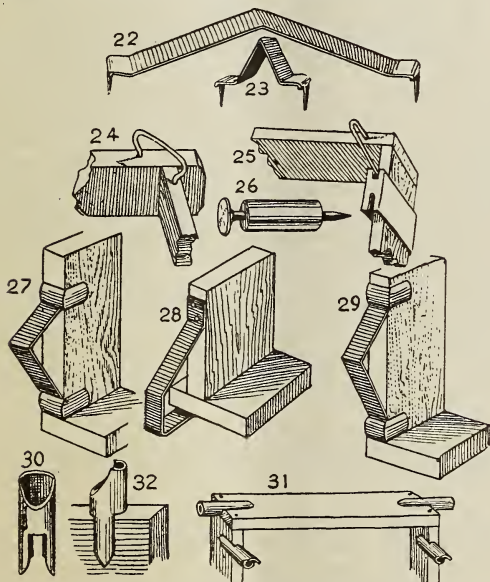

In 1859 I worked in Germany with a beehive open on one side and on the top. The frames were of the Berlepsch pattern, spaced in the same way as your Hoffman frames. The top of this hive was open so that any frame could be taken out from between the other frames, but it did not work right. To move a frame in the middle, all the frames from the open side to this frame had to be loosened and moved some distance, at least, to make room for lifting out the desired frame. By and by we found it better to take out all the frames by the open side, and the open top had no use any more. These Berlepsch frames had many disad-

vantages. They were propolized together more or less. In separating them, once in a while the wood split off.

About 1860 G. Dathe used wire nails with large heads for spacers, the same as Dr. Miller does now. Soon these nail-spaced frames were in general use in Germany in all the side-opening hives, and I used them till I went to Texas in 1879. Since this time many different metal spacers have been invented in the fatherland, and I inclose a

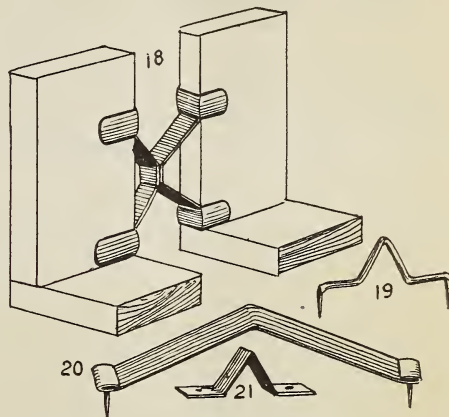

few prints from wood cuts of such spacers. Besides, different hives were invented which were operated from the top or from one of the ends, so that any single frame could be taken out between the other ones. All these hives, if spacers on the frames were used, disappeared very soon, and only such as had the spacers fastened to the hive and not to the frames are still in use. These experiences and other reasons taught me the principle that, in a side-opening hive, the spacers are correctly placed on the frames; but in a top-opening hive, or one which is operated from one of the ends, the correct place for the spacer is on the hive. If this is not observed, all the advantages of such hives over the side-opening hives are lost.

In Texas I commenced bee-keeping with the ten-frame Langstroth hive without any spacer. At that time the opinion of all practical bee-keepers was that a spacer in the Langstroth hive was not necessary, and

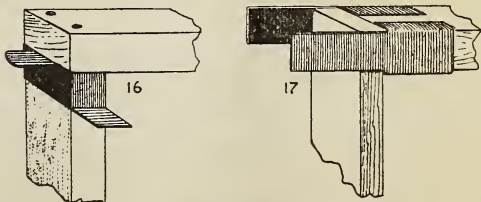

spacers on the frames were called a nuisance, as they made the frames immovable. Nevertheless, since 1880 I have used a spacer on the rabbet of my Langstroth hives, to be sure that the frames were spaced correctly and could not get out of place, and at the same time they could be handled just as easily as the unspaced free hanging frame. I still use this same spacer, and have not as

yet found any thing better. Having made these experiments I was astonished when I found in GLEANINGS that you selected the Hoffman frame to improve (?) your hives—a frame exactly like the Berlepsch frame, which was abandoned in Germany thirty years ago.

When I for the first time saw a Langstroth hive I observed at once that it was far

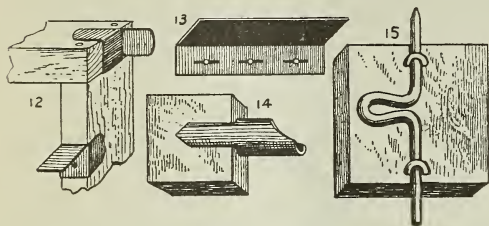

ahead of the side-opening hive, because any frame could be taken out without even touching another frame. It is quite impossible to construct a frame or hive which could be easier handled. The hive had only one disadvantage—the frames were not always spaced correctly, and this spacing took some time. Once in a while the frames moved out of place by some unknown cause. For moving the colonies, the frames had to be fastened; consequently the problem was how the frames could be fixed without losing the merits of the old Langstroth

are spaced correctly and can't move during transportation. This is the reason, I say. The principle is all wrong if a spacer on the frame is used in a top-opening hive.

If we have a top-opening hive with the spacer on the rabbet we can take out any frame. If we lift it about 1/2 inch it is out of the rabbet, and is now exactly as the loose hanging frame. For shallow frames such a spacer is sufficient. For frames as high as the Langstroth I would use a spacer on the bottom-bar too.

Now we take another hive with Hoffman frames. To take out a frame in the middle it must be broken loose from its neighbors; consequently a bunch of frames must be moved sidewise (lateral movement). To make this possible a division-board is used which must be taken out before any frame can be moved; then an instrument like a chisel is used to break loose the several frames. All these operations are not necessary at all with the old free hanging frame and with a frame hanging in a spaced rab-

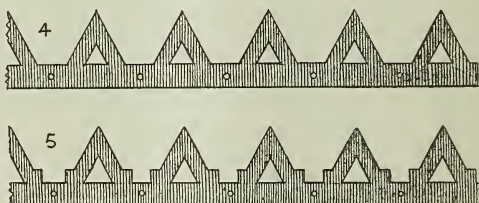

bet, and these operations take considerable time. In some localities there may be more propolis, and the gluing will be worse; but some propolis is found in every locality, and space must be given for taking out a frame, even with the new metal spacer.

I will consider another objection. Frames with spacers can't be used except with a division-board. In a ten-frame hive the only practical way is to use a strong division-board and nine frames only. This division-board needs as much lumber as a side of the hive, or nearly 28 per cent more lumber is

hive. Spacers on the frames were entirely out of the question for me. You tried to solve the problem in another way. At first you were in favor of the closed-end frames (*a la* Heddon), but changed soon to the Hoffman frame because these frames have less contact. Now you recommend a metal-spaced frame with still less contact, and so you are coming nearer to a frame without

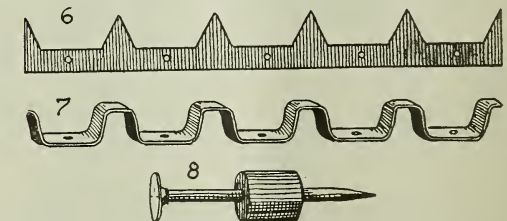

needed; and by using nine frames in place of ten the capacity of the hive is lowered 10 per cent. These are very high expenses for a doubtful advantage.

The idea of using a spacer on the rabbet has been suggested very often, but you always had a footnote saying such a device was not popular, or that it is objectionable, without giving any reason why it is so. In one of your private letters to me you said you had seen such a device and tried it, but did not like it; but you did not say why you did not like it. You will excuse me if I call this

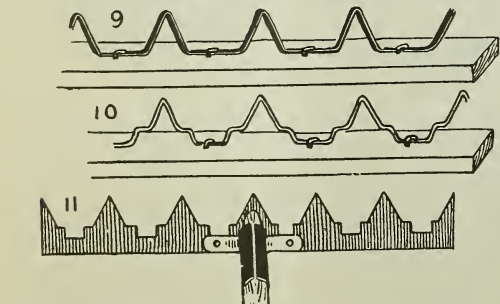

any contact. Hereby you give up all the advantages of the loose hanging frame, gaining the only advantage that the frames

prejudice. I am of the opinion that the fact that such a device is coming up nearly every year several times and in several forms is proof enough that it would be popular if it could be bought of the leading supply-dealers. Taking only the last few months of the bee-journals, I found that such men as C. W. Dayton, A. Getaz, M. Pettit, and J. Alpaugh are in favor of or have invented such a device.

On the other hand, you claim the Hoffman frame is popular, most bee-keepers use it, etc. Well, Mr. J. Hoffman used such frames for many years, but they were not popular till you recommended them in GLEANINGS. Some of the bee-keepers who use the Hoffman frame now do not know a better one; others can't help it. They are forced to take what the factories offer for sale as standard goods. If I could not make my own frames and hives I would have to use them too, for I could not get any thing better. Then it is an advantage to use standard fixtures if we want to sell some colonies, etc. Nearly every winter, before I commenced to make new hives, I considered whether it would not be better to use the standard goods. I tried them again and again, and have given them up in disgust.

You say some do not like the Hoffman frame, probably because they did not learn how to handle them; they should not be handled singly but in pairs, threes, or fours, —for instance, in forming nuclei. Further you say these spaced frames allow a lateral movement *en masse*, which we can not sacrifice.

It is true that a manipulation of hives or stories in place of single frames saves considerable time in our manipulations. For this reason I prefer a divisible brood-chamber. With this I can make artificial swarms, shaken swarms, etc., without handling frames at all. This was the idea with the Heddon hive, in which the easy handling of the loose frames was sacrificed to get them fixed as much as possible for rough handling of the hive parts. The handling of the Hoffman frames in pairs and fours is no substitute for handling stories, and can hardly be used in *practical* bee-keeping. For instance, if we divide a colony in a ten-frame hive into five nuclei, and take the frames in pairs for each nucleus, we shall hardly succeed. In one nucleus we shall have too much brood and no honey; in another one shall have very little brood. The brood in one nucleus may be all capped; in the other one, all open, etc. Even the bees are not divided correctly. No, sir. If we operate with brood-frames we must know what they contain, and handle them singly. If it should be any advantage we could handle the frames without spacers in pairs just as well, using one of the fingers as a spacer between the two frames.

Now about this lateral movement. I have to say that it is necessary with the Hoffman frame to take out a frame, but it was not necessary in the old Langstroth hive. I consider this a disadvantage, while you claim it

as an advantage which you say we can't sacrifice. For what purpose can we use this lateral movement? In the extracting-supers, I think, nobody will use it at all. It may be used in the brood-chamber for spreading the brood. In my opinion this spreading of the brood does generally more damage than good; but if done at all it must be done carefully. The empty combs must be placed between two combs where the queen is just laying eggs in the center of the combs. To find such a place, several frames must be taken out and examined; and for this reason the movement *en masse* can not be used. The better management is to use large combs in large brood-chambers, and not disturb the brood-nest at all, and not handle the frames. Another reason for a lateral movement of frames I do not know. The large brood-frames we handle in making artificial swarms in forming nuclei, shaking or brushing off bees, etc., and in all these cases we have no use for a lateral movement.

In the shallow extracting-supers, a frame without a spacer is by far the best, because it is quickest handled in uncapping and extracting. In filling the supers with notches on the rabbets, no pressing together of frames and other manipulations are necessary. The extracted frames are simply dropped into the super; and if they do not fall into the notch I strike with the hand across the top of the frames, if all are in the super, and every one falls into its own notch and is spaced correctly and will stay so. It is during the honey crop that the most handling of frames is necessary. I used ten-frame shallow supers with Hoffman frames. If they are full of honey it is no little work to get out the first frame for extracting. Sometimes it was necessary to push out all the frames at once with a device I had on hand for pushing sections out of T supers. This was one of the severest objections to this kind of frames.

I have no doubt you could easily make a practical device which could be nailed on the rabbet of your hive in place of the tin rabbets, and which could be used in combination with your all-wood frames or the thick-top-bar frames, and this would not complicate your business very much. For these high frames, another device, probably of bent wire, and fastened to the bottom-board, would be necessary; for frames 5 $\frac{3}{8}$ high, the spacers on the rabbets are sufficient. The advantages of such hives are so many that I have no doubt it will be popular in a very few years.

Cibolo, Texas.

[It is not my purpose to make any rejoinder to our correspondent. Indeed, I really enjoy having my views assailed by so able a writer. As I have given my opinions on the question at various times, it will not be necessary to repeat them here, any more than to correct a misapprehension on the part of Mr. Stachelhausen by saying that I am not an advocate of any particular frame, as a good deal depends on locality, the bees,

and the bee-keeper. Different conditions make it necessary to give different advice to different people.

It may be well, perhaps, to state that the Hoffman frame does not, as our correspondent seems to infer, require the use of a division-board. If we were to start anew, making the eight-frame hive, we would not make it wide enough to take in such a board. Personally (and that seems to be the experience of most of our correspondents) I can handle the Hoffman frame easier than a division-board. Since the eight-frame hive was made half an inch wider to accommodate this article, nothing remains but to continue making it so. When we began making the ten-frame hive we did not make it half an inch wider, believing it to be better to dispense with the division-board in that hive.

While the editor still believes in having the spacers on the frame, and that it would be a mistake to put them elsewhere, he is very glad to have so able a correspondent, who holds the opposite view, explain the advantages of the rabbit spacer. — ED.]

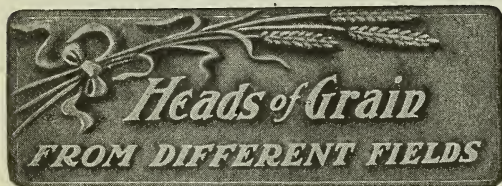

COMBS THAT HAVE BEEN IN USE 20 YEARS.

A matter that was up in GLEANINGS a few years ago was, who had a set of combs twenty years old? I have combs that were built in the spring of 1885, and they have been in use continuously ever since. They now occupy the bottom story of a three-story hive which I run for extracted honey. I have had combs built every year since that date, as that is when I commenced keeping bees.

W. W. GRANT.

Marion, Ill.

[I might explain for the benefit of our newer readers that the statement was made some time ago, that, when a comb got to be six or seven years old, it should be discarded because the accumulation of cocoons in the cells would reduce the size of the cells to such an extent that the bees hatching out after the sixth or seventh year, at least, would be smaller than those first reared in the same cells. The editor and some others took the ground that there was no truth in this—that when there was an accumulation of cocoons the excess would be removed by the bees, and that, therefore, the last reared bees would be as large as the first ones.

Since that time we have had numerous reports of combs anywhere from 25 to 30 years old that are doing good service; and the bees reared from them have apparently the same

size as those reared in combs right next to them, from combs just built off from foundation.

Among others who gave substantial testimony to this was the veteran R. Wilkin, of Ventura, Cal., one of the most extensive bee-keepers the country has ever known. Just before he died this contention was up, and through his daughter he sent me word that he had combs 30 years old that were then doing excellent service. It would be very nice for us foundation-makers to give out the statement that all combs should be renewed every seven years. If that were true, every bee-keeper would have to buy large quantities of foundation; but, fortunately for the consumer, if not for the manufacturer, the facts do not bear out the contention. — ED.]

SHOULD QUEEN-EXCLUDING ZINC BE SEPARATED BY A BEE-SPACE FROM THE TOP-BARS?

Would you kindly tell me how to use the queen-excluder? Should there be a space between the zinc and the top of the frames? If so, how much? I notice the English excluders have the perforations running at right angles with the frames. They are placed flat on the top-bars.

R. J. MELVILLE.

Cambridge West, New Zealand.

[While it is not absolutely essential, it is better to have a bee-space between the perforated zinc and the brood-frames, above and below. The wood-bound boards are so made as to provide for this space, providing they are put on the hive right side up, and not wrong side. The unbound zinc boards will probably sag on the brood-frames below. This will do no particular harm, except that the bees wax them down, making it more difficult to remove.

The English excluders have the perforations going crosswise of the frames, probably not because there is any advantage in that arrangement, but because the size of the English hives makes the zinc cut to better advantage when the perforations are so placed. Many of the excluders for English hives are 16 inches square. In that event the perforations might run either way. — ED.]

COMB BUILT OVER WIRES WITHOUT EVEN STARTERS OF FOUNDATION.

In *Star Straws*, page 343, I see the following: "Natural comb built below the starter will be built over the wires," p. 301. Yes, but the wire will not be in the septum."

I have a piece of comb built on a wired Hoffman frame, *without even a starter*. The bees had to start on the side of the groove in the top-bar. They did not exactly disprove the words of Dr. Miller, because they had no starter to commence with. It happened in this way:

I made a mistake last summer while extracting, in putting on a super of empty wired frames (I had supers with wired

sheets of foundation near) on the hive of a strong colony; and upon examination of the colony a few weeks later I found that the bees had nearly completed the fourth frame, and some on the fifth. None of the frames had starters, and there were the grooves to contend with. If the bees could engage the wire and septum *without* a starter, it looks reasonable, to a beginner, that they would do so *with* a starter. DAVID S. HURST.

Davenport, Ala.

[The wire will be in the septum of the naturally built comb, provided the comb-guide, or narrow strip of foundation, even though only $\frac{1}{4}$ inch wide, is placed directly on the central line on the under side of the top-bar. But when naturally built combs are put on the under side of a double groove wide-top frame, the bees are liable, unless there be a narrow strip of foundation, to build from the central strip of wood between the grooves, thus bringing the septum of the comb out of the center and out of alignment with the wires. It is very poor policy to give bees empty frames without a comb-guide, or, better still, a narrow strip of foundation centrally placed, even though that strip be no wider than $\frac{1}{4}$ inch. No bee-keeper can afford not to use narrow starters of foundation; and a good many think they can not do with less than full sheets because of the difficulty in getting irregular or a lot of drone combs.—ED.]

PERPENDICULAR WIRING PREFERRED.

I have a number of frames wired, some horizontally and some perpendicularly. All of these I had came in hives I *bought*, and, without exception, those wired from top to bottom are filled clear to the bottom, while there is quite a space between the bottom of the comb and the rail in the others.

Boston, Mass.

C. H. HOWARD.

[There can be no question that perpendicular wiring will give better results than horizontal. By the latter method a number of the cells near the top-bar elongate in such a way that the bees use them for storing purposes. However, it should not be understood that the perpendicular wiring alone will result in solid cards of comb without any honey below the top-bar, for much will depend on the queen and kind of season. But I think we may safely say this: That perpendicular wiring will result in more brood being reared in a Langstroth frame than by the horizontal plan.

The only difficulty in the way is, it is not practicable to use the perpendicular plan with the modern thick-top frame as now made. Dr. Miller gets around the difficulty by using splints in place of wires. The question might arise why we never advocated these splints. Chiefly because of the difficulty of making them in a wholesale way; and, secondly, because we doubt if the average bee-keeper will so imbed his splints as to get good results.—ED.]

THE ALEXANDER TREATMENT, AND POLLEN IN THE COMBS.

In thinking over the principles of the Alexander treatment for black brood, one question arises: Will not the bees during the quite long interval in which they are queenless and broodless plug up the brood-combs with pollen? I had this happen late last summer when one of my colonies became queenless, and this spring these same combs were still full of the hard dried-up pollen, and were in a very moldy condition.

West Lafayette, Ind. WILL A. HORST.

[A good deal will depend on the season as to the amount of pollen that might be put in the combs; but a queenless colony will leave the cells in the center of the brood-nest clean and polished. The presence of the pollen in the surrounding cells would do no particular harm unless it might be the means of covering old diseased germs in the comb.

This reminds me that perhaps I ought to state that the foul-brood inspectors of New York do not believe that the Alexander treatment for black brood will prove to be entirely satisfactory. While they admit that the general effect of the treatment is repressive in that it checks or keeps back, and in many cases effects a cure, they do not advise any one to rely on it. They think that nothing short of shaking the bees on foundation, and compelling them to draw it out into comb, will prove effective. When I asked why it was that Mr. Alexander had by his plan been able to clear his yard of the disease, when it was present in other yards in the locality, I was told that black brood in New York has practically run its course; that a repressive treatment might and probably would prove effective under those conditions.

It is well known in science that a disease after it has run its course through a section for a time seems to lose its virulence; or, perhaps, to put it more exactly, the survivors are more able to resist the onslaughts of diseases that are just as poisonous as ever; but when such disease starts in a *new* locality, the foul-brood inspectors of New York believe that nothing short of the McEvoy treatment should be used.—ED.]

A LETTER FROM A TEN YEAR-OLD BEE-KEEPER CONCERNING HIS FIRST COLONY OF BEES.

I am only ten years old, but ever since I can remember I have been very much interested in bees. Last spring I bought a colony of mixed black and Italian bees. I got about one pound of honey from them. They came through the winter all right. I expect to get an Italian queen. My bees are rather cross, but I don't mind a few stings now and then. I hope to get a good swarm this spring.

WENDELL T. CARD.

Kingston, R. I.

[We congratulate our young friend on his success for one so young.—ED.]

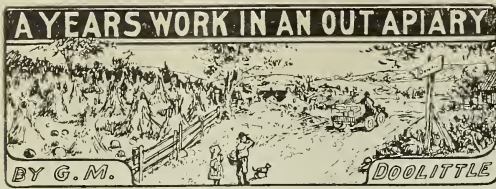

CHAPTER X.

TAKING OFF THE HONEY AND STORING IT AT THE OUT-YARD.

From two to four days later, in accord with the weather, I go again, the same making the tenth visit, when the supers are taken off, free from bees. I said, "According to the weather," for the reason that a hot clear day is not suited for the work we must do at this time, when there is no honey coming in from the fields. Robber bees would drive us home long before we could get the work done. The day desired is a cool cloudy one—one so much so that it will keep the bees in their hives. I do not usually go till afternoon, as by noon it can generally be told what the rest of the day will bring forth.



In taking off the supers, those that have no honey in them are piled up top of each other till they are six to ten high, when a cover is put on each pile, and a 25-lb. stone on the cover, where they are left until wanted for use the next year. As many of those having honey in them as I can carry are packed into the auto or wagon, in accord with which I have with me; and if there is more than I can carry they are piled up, as were the empty supers, seeing that each pile is bee-proof, to wait till I can draw them home. The tiered up hives are now piled away (using the wheelbarrow as much as possible in all this work), the same as were the supers, those being heavy with honey being piled by themselves, and the light ones in a separate place. These are our reserve combs for next year.

"SWEETENING" UP THE NEIGHBORS.

I now take off the escape-boards, put the covers on the hives, and store away the escapes for the next year. Some are deterred from starting out-apiaries by what they consider necessary—an outlay for buildings to store things in; for should they continue only a year or two at any place with an out-yard, such buildings would be almost an entire loss. But I do not find it necessary to have any thing more at the out-apiary than a few extra hives and covers, and often all but two or three of these get into the bees' possession before the season's work is ended. Smoker fuel, smoker, bee-veil, tools, etc., are stored in these hives; and with the finish up in the fall all are piled away as I have given, where they stand right in the bee-yard all the fall, winter, and spring, till they are needed again, the hives and supers giving all the protection that I find necessary in this locality, and all that is needed in any locality, in my opinion, unless it should be the "wild and woolly" West, where thieves are liable to carry off every thing not under lock and key. And even there a few pounds or sections of honey handed out to those living near the out-apiary will generally win for miles around. No one knows how a few sections of honey given to the half-dozen families living near the out-apiary will *sweeten* for miles around till they try it. The few receiving these little tokens will be *your* friends; and as those further away are the friends of these few, the good words they say about you will make friends of the whole, so that all will almost fight for you, and if they want some honey they will come to you to purchase it, never thinking of taking it otherwise. But be *stingy* with the product of your out-apiary, so the few nearest it call you "a louse," then there will be no end to the annoyance you will have, and I guess this will apply in nearly equal terms to the home yard as well.

WEIGHING UP THE HIVES.

When I come to the colonies which were tiered, I weigh them, as some are liable to be short of stores, through storing too much in the combs above; and any that are light are supplied with plenty by giving them full combs taken from the "heavy" pile in exchange for their light ones. I do not now look after the stores of those that worked in sections, as it is seldom that there is a lack with any of these, as the plan used, together with the ten-frame hive, nearly always causes the storing of plenty of honey for winter. If, when turning the bottom-boards for winter, at our next visit, any are found to be light, a change of heavy combs for some of their light ones is made, so that all are known to have 25 lbs. or more, which is amply sufficient for all their needs till they can be looked after in the spring, when starting them on their road to prosperity, for both themselves and owner. After again carefully looking over all the piles of hives and supers containing honey, to see that there is no crack or hole about any of them

sufficiently large for the entrance of a bee, and giving a general glance over the whole, to see that all is in good condition for leaving, I am ready for my journey home. And this is what was done on the tenth visit.

A RETROSPECT.

As I am about to leave I can not help taking a last lingering look at things, as they have so changed since I came at noon. Instead of tiered-up hives, and those with supers, which have gradually grown up with me during the summer's work, all have assumed the appearance of what they had in spring, and I am reminded that the work of the bees is over till another year. A sort of sadness steals over me, and I fall to wondering if both bees and myself will be alive to work so happily together another year. The merry hum, and the fragrance from the hives, which greeted me when coming to the yard during the summer, greet me no more. I find myself wishing it were spring again, and that I were just commencing the fun of working the out-apiary for another year. I seem to see the bees at work again as they did on those bright "clover and basswood" morns. It seems like a real living picture again—a picture fairer than thought; a picture fairer than a dream; a picture with ten thousand pearls glistening in earth's rarest sunlight, on one stretch of verdure green, and reaching out beyond the winter's vale to the bright spring again, when the butterfly begins to flutter in the pleasant breeze, and the joyous children are chasing after sunbeams. Thus I dream. As I have been



musings, the clouds have parted in the low west, and the setting sun has dropped down into the clear space between them and the horizon, throwing over hill and vale ten thousand times ten thousand glittering hues

that glow and shine to beautify the landscape and cheer the heart of man. Dawn tiptoes over the mountain tops, and peeps into the valley far below with eager, tender eyes, while darkness gathers up her sable robes to skulk and hide away into the crevices and mountain caves; but in the evening come the long light sunrays, beautiful to gild the world and gladden it with kisses, lovelier, sweeter far than the rarest, gentlest kiss of dawn. So, too, the evening tide of life may grow more beautiful and blest if life is rightly lived, believing upon Him who was and is the light and life of men. And the bees, now in the evening tide of 1905, are enjoying a rest sweeter by far than their restless sleep during the dawn of their activity, six months ago.

"Hello there! Gone to sleep?" comes in stentorian tones from my farmer landlord, and I am aroused to the fact that it is fully time that I be on my journey home.



WHERE DID THE CLOVER SEED COME FROM?

Some four or five years ago a huge trunk sewer was run through our town from the southern end of Boston to the sea—some fourteen miles. This sewer was an open cut in some places; in others it was tunneled. As it was planned to build a 100-foot boulevard over it, the material excavated was, for the most part, spread over this 100-ft. space as the work was completed. It consisted mostly of fine sand or gravel, and in some places clay or quick sand. Well, everywhere this material was spread a dense growth of white and alsike clover sprang up, and this year there is quite a crop, although it is running back to weeds now. What I should like to know is, where did the seed come from to cover so thoroughly every part of this new ground dug from depths varying from twenty to forty feet? Some say the seed was in the sand, and only needed the sun and air to spring into life. This theory seems foolishness to me.

East Milton, Mass.

ROBT. FORBES.

Friend F., this is indeed a puzzling question; and had I not heard of instances similar to it I should say that somebody sowed the seed of white clover in the alsike, and I think now that it must be this seed was sown by the company that built the sewer, or by somebody else without the knowledge of the residents along the route. Clover can not come up where no clover seed has been sown, any more than corn can come up where no corn has been planted; and various experiments at our experiment stations have pretty well settled the question that clover seed can not germinate after a certain number of years. I can not put my hand on the table just now, but I think the vitality will all be gone in fifteen or twenty years—may be more or may be less. In our own experience in handling seeds we find some clover seeds lose their vitality entirely in less than a dozen years. This has hap-

pened several times when seeds have been overlooked or had gotten among the rubbish.

Where excavations are being made, the seeds of certain weeds are known to germinate after a long period of years; but all the stories about the seeds of grain thousands of years old, etc., are, without question, humbugs. Perhaps some one who is familiar with the recent investigations in regard to how long other seeds may hold their germinating powers can tell us a little more about it. I am well aware that clovers often spring up in unexpected places; but I am quite sure that careful investigation will generally tell where the seed came from.

CAN ANYBODY ON THE FACE OF THE EARTH MAKE IT RAIN OR STOP RAINING?

So many people have asked my opinion in regard to rain-makers, first and last, especially the recent rain-maker of California, I have concluded to submit the following, which I clip from the United States *Monthly Weather Review* of a recent date:

A FAKE RAIN-MAKER.

Mr. Otto J. Klotz, the Chief Astronomer of the Dominion of Canada, and a very active friend of honest meteorology, kindly sends the following extract from *The News*, of Toronto, March 1, 1906. We know of no better way to protect the public than to expose the pernicious activity of the fake rain-makers, the hail-preventers, and the planetary forecasters:

Ottawa, March 3.—In the appropriation ordinance passed last autumn by the Yukon Council appears a vote of \$5000 for the purpose of "encouraging meteorological experiments on the Dome"—the peak which dominates the vicinity of Dawson—"in the summer of 1906." This innocent item covers one of the quaintest pieces of administration ever perpetrated by a Canadian legislative body.

The rainfall is an important consideration in the Yukon, as the miners need water for their operations, and a wet summer is as advantageous as a dry one is the reverse. So far as observations extending over a very few years can serve as an indication, wet and dry summers roughly alternate. The summer of 1905 was marked by a drought, so that the balance of probabilities is in favor of a rainy summer this year.

Southern California for some time has been the home of a rain-maker, one Hatfield, whose method of operation seems to be the liberation of certain chemicals, which are supposed to induce showers. Mr. Hatfield has advertised his methods and his alleged successes with some enterprise, and the administration of the Yukon has become an admirer of his. The "meteorological experiments" are to be conducted by him, and the \$5000 is for him.

STANDS TO WIN ANYWAY.

Private persons have subscribed \$5000, and the Yukon Council supplies another \$5000. Mr. Hatfield is to spend the summer in the country, and his expenses, estimated at \$2000, are to be defrayed in any event. If it rains, he is to get the other \$3000. Thus Mr. Hatfield occupies an advantageous position in the bargain. He will get \$2000 expense money in any event, and he will get \$8000 more (1) if he "makes" the rain, or (2) if the rain happens to come independently of his liberation of chemicals. Moreover, as already noted, in any event the chances favor rain this summer.

Next, who is Mr. Hatfield? The standing of the United States Weather Bureau at Washington can not be doubted. A request for information, addressed to the Bureau, elicited the following reply:

"Mr. Hatfield attained considerable notoriety in the United States last fall as a pretended rain-maker, operating in Southern California. The judgment of the Weather Bureau as to this pretension may be found in the accompanying extract contained in the closing paragraph of a letter written by the Chief of the Bureau, October 20, 1905, in reply to a request for information relative to Mr. Hatfield:

"It is, therefore, apparent that the rainfall which

was supposed to have been caused by the liberation of a few chemicals of infinitesimal power was simply the result of general atmospheric conditions that prevailed over a large area. It is hoped that the people of Kansas and of other regions in the subarid West will not be misled in this matter, and give undue importance to experiments that doubtless have no value. The processes which operate to produce rain over large areas are of such magnitude that the effects upon them of the puny efforts of man are inappreciable."

In another letter on the subject, to be found in the issue of the MONTHLY WEATHER REVIEW for April, 1905, Mr. Willis L. Moore, the Chief of the United States Weather Bureau, corrected some statements put forward on Mr. Hatfield's behalf. "Your dispatch," he wrote, "stated that the heaviest rain fell in the region of the rain-maker, and that the rainfall had not been large in any of the other regions of the subarid West. This statement is erroneous, as during the same period general and excessive rains occurred throughout Arizona and New Mexico. It is known that when barometric pressures for a month are low in the Southwest, the period is one of frequent and heavy rains in that region, and this barometric condition prevailed over New Mexico, Arizona, and Southern California during the three-month period under consideration."

It is rather disagreeable to reflect that at the very time that these warnings were being issued against Mr. Hatfield, the administration of the Yukon was proving so easy a mark for his efforts. What makes this more striking is that the Yukon Council is not a particularly democratic institution. It is a strongly official body, perhaps a majority of its members being selected from Ottawa—presumably on account of their intelligence, general information, and administrative fitness.

NAVIGATING THE AIR.

On page 832 I spoke about a young man who started to make a balloon ascension on Sunday. Well, I do not know whether he gave up making Sunday flights or not; but the following clipping from the *New Voice*, of Chicago, indicates that he is having better luck in making his ascents on week days:

Members of the present Congress naturally are interested in ways and means of getting off the earth.

Public business was practically suspended last Wednesday for several hours while Lincoln Beachy was giving a wonderful exhibition of aerial navigation in the suburbs above Washington.

The experiments are said to have been the most successful ever performed, particularly in the features of control and dirigibility.

The airship, rude in construction, responded accurately to the will of the boy aeronaut. He compelled it to circle Washington monument and the great dome of the capitol, descended and made a landing when and where he pleased, and demonstrated to the satisfaction of the thousands who witnessed the exhibition that many of the rudiments of aerial navigation have been solved.

Santos-Dumont and others who have become famous because of successful flights in air-ships never accomplished what young Beachy did. In an airship sixty-two feet long and sixteen feet in diameter, suspended from a gas-bag with a capacity of 10,000 cubic feet, made of 750 yards of Japanese silk, with a two-bladed propeller in front and a large rudder, the daring aeronaut made a flight of nearly twenty miles without serious accident.

Employed to make ascensions at a suburban resort, young Beachy, in an airship patterned after that used by Roy Knabenshue, whom he had been assisting, decided to demonstrate its practicability by a flight around Washington, visiting the principal points of interest. From a point five miles down in Virginia, Beachy safely crossed the Potomac and headed for the Washington monument.

The framework of the airship, which looked like bamboo fishing-poles, consists of two parallel rods running lengthwise upon which he stands, and a third placed above upon which he sits.

A couple of small braces broke before he reached the monument, and Beachy decided to make repairs. Without any difficulty he brought the airship to earth by the use of a rope, and easily repaired the broken parts. Again he ascended. When fully 300 feet above the ground he circled the Washington monument, and, go-

ing higher, at 500 feet he repeated the operation. Then deliberately turning the airship in the direction of the White House he proceeded to call on the President. He alighted safely in the inclosure back of the executive mansion.

The President was attending a commencement exercise, and was not at home to welcome Beachy. Mrs. Roosevelt with keen interest watched his daring performances.

With the ease of a bird Beachy and his machine again sought the upper air currents, and safely above the towers of the buildings the first tour of the famous Pennsylvania Avenue by an airship was made.

Beachy circled the capitol dome, showing that he had absolute control of the airship, and made a landing on the east front opposite the rotunda. He was loudly applauded as he stepped from his machine and modestly received congratulations. After a brief rest he again ascended; and, passing over the capitol, returned to the Virginia resort, crossing three miles of housetops and a river one mile wide.

I am sorry, friends, I can not give you a report from the real flying-machine made by the Wright brothers; but one will come very soon if you will be patient. The one given above indicates what can be done by the aid of a balloon, and I am glad to see young Beachy with his home-made machine is making progress, even if he does require a balloon to keep him up in the air.

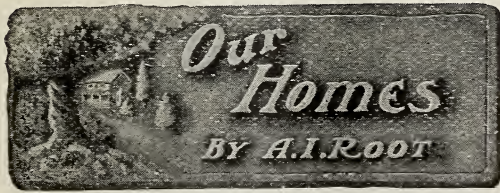

“Ye are of more value than many sparrows.—LUKE 12: 6.

ALMOST A MAN.

About July 1st I had planned going back to the cabin in the woods; but as Mrs. Root could not at that time go with me I rather decided to go alone; but on my return from the Philadelphia field-meeting my two eldest grandchildren, Leland Root and Howard Calvert, boys of 15 and 14 respectively, put in a plea to go in Mrs. Root's stead.

“But,” said I, “boys, I am planning to live up there in the woods on ‘uncooked food,’ and you two growing chaps wouldn't think, after the way your mothers have been giving you three good ‘square meals’ a day you could ever put up with that.”

“Yes, we can; yes, we can,” they both put in; “besides, our mothers have been giving us lessons, and we can cook tiptop. We will cook for you as good as grandma does. You just take us along and see. We won't make you any trouble.”

The matter worried me somewhat. I have been telling my friends of late, as an excuse for rushing about so much, that I am trying to be “where God needs me most,” and this implies I am trying to do what God wants me to do most, without much regard to selfish feelings. I am more than 50 years older than these two, “almost men” in stature, and almost *young* men in

intellect. A good many of our ideas are in widely different channels. I meditated that they would likely displace, lose, or break my tools, step on my choice plants, litter up the cabin, etc. One reason why I enjoy this home in the woods is because nobody touches any thing there but myself. No dog, chickens, nor *children* (may God forgive me) meddle with or disturb my work, nor interfere in any way with my old-fashioned (and perhaps cranky) notions.

While thinking of this, another and a better spirit suggested, “But, Mr. Root, these boys are not only your own flesh and blood, but they, in God's providence, will soon be the sinews of ‘The A. I. Root Co.’ Is not God's voice back of their boyish pleading to go with you? and may it not be the opportunity of your life to instruct and guide them at just this crisis in their lives, that they may preserve and hold up whatever the firm that bears your name has honestly earned in years past?” Then I thought of the Savior's words, “Ye are of more value than many sparrows.”

When I fell in with their plan they put in another plea, that I must wait until after the Fourth. Now, I was rather planning to get *away* from the noise and din of this event; but *God* was leading, and not I.

At Traverse City the liveryman wanted a little more time to get his rig ready, and suggested I surely wanted to take a little while to show the boys around and “*buy them some cigars*”

“No, sir! my boys don't use cigars.”

“But they haf' to learn. All boys learn some time; might as well learn now as later.”

Of course, this was pleasantry, more or less, but I invariably thanked God that these two, with the bringing-up they have had, would almost as soon think of jumping into the fire as to touch tobacco in any shape.

Dear parent or grandparent, I have now, as I write, been with these two boys close on to two weeks, and it has been a wonderful revelation to me of God's love, and of something I hardly dreamed of before, that I should, after all these years, *for the first time*, learn to know and *love* my own flesh and blood. There have been anxious times, and there have been times when I *prayed* as I seldom pray of late years; but there have also been wonderful answers to prayer. It has been a drill for me as well as for the boys; but, thank God, I think it has been a loving drill on both sides. As I give a few of the incidents by way of illustration I feel that some parents will say I have been too easy and indulgent; and then, again, there will be others who insist I have been too strict and puritanical, especially for this present age.

In two things particularly the boys' inclinations were not just in accordance with my “notions,” as some might be pleased to call them. First, how much work should boys of fourteen and fifteen be called upon to do, say during vacation time? Secondly, how much liberty should boys of that age

be given on Sunday, say after Sunday-school or other religious service?

Grand Traverse Bay is about half a mile through the woods from our cabin; and as soon after our arrival as the dinner things could be gotten away the boys were off in high glee for the Bay. The great number of springs along the hills, that empty into the Bay, make its waters of crystal clearness, and it was hard work to get the boys to come home, even at mealtime, so attractive was their sport in the water. Strawberries are at their best here in July; and along about the 10th a neighbor invited us to come over and help ourselves. It was nearly two miles, and the boys, with some diffidence, informed me they had a "raft" that would take me there. The materials were logs and other driftwood from the beach, held together with some large spikes they found in our barn. A potato-box formed my seat in the center of the raft, and a canvas awning kept off the July sun, while a couple of barelegged boys in bathing-suits waded on the white sandy bottom and furnished the propelling power. I played I was a "sultan" of olden time "sitting in state" while willing slaves "rushed" my craft to destination. When I reached the neighbor's, however, I looked more like a "shipwrecked mariner" than either sultan or pasha, for not only were my shoes and stockings soaked, but I was pretty well soaked up to the knees. Strawberries? Well, I should say! Mr. Palmer said he *lost* over fifty bushels because he could not get pickers for either love or money. We saved a part of the fifty bushels when they (Warfields) were just lying in heaps on the ground, and dead ripe.

Well, the boys were having so much fun in the water, and with some newly found neighbors, that, no doubt, they found it hard to stay away from the Bay on Sunday. After Sunday-school (we have preaching only on alternate Sundays), while I was having my after-dinner nap they ventured down to the Bay, and a boy they knew said he had got to take a borrowed boat home, and they could ride as well as not, and finally they managed to do more traveling (and *visiting*) on Sunday than on the week days, not getting back until it was so late I was really alarmed, for I hadn't the remotest idea as to where I should go to find them. Their boyish excuse for not getting permission was, they didn't want to wake me up. I didn't scold very much (*some* of you may think not enough); but I had *prayed* over the matter, and the Holy Spirit admonished me that I needed to be careful about holding my "grip" on the boys, and that said grip must—first, last, and always—be a "loving grip."

When Sunday came again I planned to remind them the first thing in the morning that it was my request they should not go at all to the Bay on God's holy day. We had been having hard work all the week to get one of them up to breakfast; and as it was Sunday I thought I would let him have a

good rest, especially as he had played hard the day before. Imagine my surprise, when I began to call, to be told by the other one he got up and went out very early. If you haven't learned it already, let me inform you that a boy of fifteen *often* shows more judgment and consistency than you might expect; but when you least expect it he shows *boy* sense and nothing else. After breakfast I went down to the Bay to hunt him up. He was coming along unconcerned, dragging a *log chain*. His explanation was, their raft got grounded so they had to have a team to pull it out. The owner of the team was so busy week days, the only time he could work for the boys, free of charge, was Sunday morning. Now, this boy—this boy *whom I love*, mind you—argued with me all the way home to prove to me that there was nothing inconsistent in his getting up *earlier* Sunday morning to help pull out that raft before he went to Sunday-school. I didn't lose my grip, however, for both boys of their own accord went to Sunday-school in the morning and to preaching again in the afternoon, and the church is more than a mile (over big hills) from our home.

A big circus has just been through here. I felt so sure its influence would not be good over the young members of our little church (or old ones either for that matter) that I spoke of it in prayer-meeting. I did not advise telling the children they *must not go*; but it seems I was enabled to give such counsel that very few *wanted* to go. Our boys did not even care to go to see the "parade," and they tell me that several of their companions who had a chance to go chose to have a holiday at home.

Perhaps you would like to know how the cooking turned out under the management of a boy of 14. Well, he not only learned to get up a good square meal, but by some careful and patient drilling on my part, as well as the instructions his mother had given him, he became able to wash the dishes and put them away, and slick up the kitchen generally, almost as well as grandma herself could do it. Not only that, he washed his dish-cloths, wiping-cloth, napkins, etc., and hung them out to dry, and kept every thing in up-to-date shape. The other boy did not take so kindly to cooking, but he trudged faithfully every day half a mile through the woods and over the hills after bread, butter, milk, etc. For a spell it took a ten-cent loaf of bread for each meal, and a chunk of honey cut out of a frame from one of those Caucasian queen-rearing bee-hives, once a day or oftener. When we went to bed tired out at night, the boys were at first much inclined to drop wearing apparel on the floor, or in "any old place;" but with plenty of nails in the rough board walls I finally persuaded them, even in the night time, to keep things "decently and in order."

With a prayer that this Home paper may enable some other parent (or grandparent) to "hold his grip" on these boys in their teens, and still guide them in the "straight

and narrow way," and that it will remind them, also, that *these boys* are of more value "than many sparrows," I still remain your old friend,
A. I. ROOT.

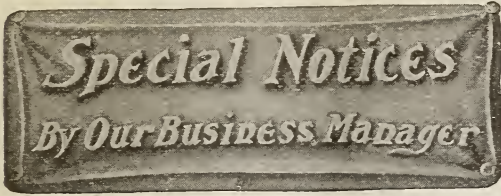

THIRD PHOTO CONTEST.

We want bright interesting photos to illustrate GLEANINGS. Send in those you think suitable, and you will stand a chance of one of the prizes below:

CLASS A.—Photos of general interest, excluding swarms and apiaries. Prizes: 1st, \$5.00; 2d, \$3.00; 3d, \$2.00; 4th, cloth-bound A B C.

CLASS B.—PHOTO OF SWARMS. Prizes: 1st, \$3.00; 2d, \$2.00; 3d, A B C of Bee Culture; 4th, GLEANINGS one year.

CLASS C.—PHOTO OF APIARY. Prizes: 1st, \$3.00; 2d, \$2.00; 3d, A B C of Bee Culture.

SPECIAL—Photos that do not win prizes but which we can use will be awarded a prize of \$1.00 each.

CONDITIONS.—Contest closes Nov. 1st.

All photos should be marked "For Contest," and have name and address attached. Prize-winning photos become our property. No photo returned unless stamps are sent. We prefer unmounted prints toned to a light-reddish color on solio paper.

WINNERS IN SECOND GLEANINGS CONTEST.

Below is a list of those sending the largest list of subscribers as per conditions in our second contest:

PRIZES.

First prize, \$10.00 queen, A. K. Ferris; 2d prize, \$7.50 queen, L. Riebel; 3d prize, \$5.00 queen, Roy Wood; 4th prize \$3.00 queen, F. D. King; 5th prize, \$2.00 queen, Wm. C. Wilson.

Sixth to fifteenth prizes, one cloth-bound A B C, W. T. Crawford, J. H. McCargo, H. C. Overson, Fred W. Allen, Oliver D. Corman, G. O. Evans, E. L. Blair, Geo. W. Copenhaver, D. T. Gaster, Albert E. Wurster.

Sixteenth to 25th prizes, one Junior Cornel smoker, Rudolph McChesney, E. C. Selley, G. P. Berg, J. A. Yeomans, Wm. F. Elert, B. E. McSwain, Martin Gute, H. Burritt Goodwin, G. A. Kreigbaum, Marion Nine.

Have you entered our fair contest? Our prizes are very liberal, and so many that practically any one who makes an effort to secure a few subscribers wins a prize besides our large commission. We want GLEANINGS agents in every county.

THE PAWLONIA IMPERIALIS.

At this date, July 30, the tree is 7½ feet high, and there are several leaves that are over 30 inches across. Even if it dies down during winter (and I hardly think it will), the tree is worth to me a dollar for one season. See page 954, last issue.—A. I. R.

G. W. PARK, LA PARK, PA.

Quite a number of friends have reminded me that I failed in our last issue to give Mr. Park's address, which is as above. Well, I am sorry for my blunder, but it indicates I had not in mind giving Bro. Park any "free advertising." As his circulation is so large I supposed most of our readers knew where he is located.—A. I. R.

JOSEPH HORNE CO.

Pittsburgh, Penn.

The Hoe Safety Razor.

All beards are alike to the Hoe, the heavy gristly beard that requires to be reduced every morning, and the light, unnoticeable beard that calls for a shave only twice a week.

The Hoe Safety Razor is by all odds the simplest safety razor on the market to-day, as well as the most perfect. It is composed of three parts, the hoe, the guard, the razor itself; and this razor can be honed when necessary just like any other razor.

It costs only \$1.50, and the price includes half a dozen keen-edged blades, which ought to last any beard a couple of years. Then you can buy more blades.

Swarthmore Books!

BABY NUCLEI (2d ed.)—The second edition of this popular treatise is on the press. This book thoroughly covers the field of small mating under management. The experience of twenty years in mating young queens in baby nuclei is given. A delightful little book—good printing, enjoyable reading, and easy understanding. Price 25 cts. postpaid.

SIMPLIFIED QUEEN-REARING.—A revised edition of this book just out. It tells the honey-producer how to rear queens by the very simplest method ever published. Good queens for little money and little trouble, in just an effective and economical plan for the bee-keeper who works for profit. Price 25 cts. postpaid.

INCREASE.—Don't depend entirely upon swarming for your increase. It's too slow and uncertain. Swarthmore tells of a way in his delightful little book entitled "Increase"—a natural way, simple and safe, no labor, little trouble. Colonies formed on this plan will work like prime swarms, and store a surplus. Price 25 cts. a copy postpaid.

CELL-GETTING.—The plan that has revolutionized queen-rearing throughout the world. The entire process is fully explained and illustrated by photos from actual life. Price, postpaid, 50 cts.

SWARTHMORE QUEEN-REARING TOOLS.—Complete outfits or separate parts. Write for price list.

FOR SALE BY

The A. I. Root Company

ALL BRANCHES AND AGENCIES

Fire Sale Bee and Poultry Supplies

Come or send, and save 25 to 50 per cent on slightly damaged goods. NEW LEWIS GOODS at factory prices by return freight. Golden Italian or Red-clover queens by return mail. Untested, 75c; select untested, \$1.00; tested, \$1.25; select tested, \$2.25. Full colonies in up-to-date hives, and nuclei.

H. M. Arnd, Propr. York Honey & Bee Supply Co. (Not Inc.)
Long Distance Telephone, North 1559. 191 and 193 Superior St., Chicago, Ills.

"If Goods are wanted quick, send to Pouder."

Established 1889

Bee-Keepers' Supplies

Distributor of Root's Goods from the best shipping-point in the Country. My prices are at all times identical with those of The A. I. Root Company, and I can save you money by way of transportation charges.

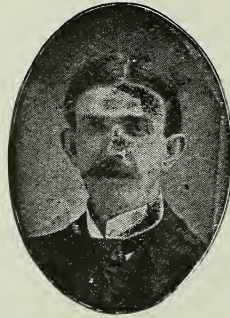

New Metal-spaced
Hoffman Frames
are Here in Stock

Headquarters for the
Danzenbaker
Hive

**Dovetailed Hives, Section Honey-boxes,
Weed-process Comb Foundation,
Honey and Wax Extractors, Bee-smokers,
Bee-veils, Pouder Honey-jars, and,
in fact, Every Thing used by Bee-keepers.**

BEESWAX WANTED!

I pay highest market price for beeswax, delivered here, at any time, cash or trade.
Make small shipments by express; large shipments by freight.
Always be sure to attach name to package.

Catalog Free

Walter S. Pouder
513-5 Massachusetts Av., Indianapolis, Ind.

Bee = keepers!

Are you aware that we are manufacturers, and can supply you with every thing you need in the apiary?

Good Goods, Low Prices and Prompt Shipments

are the POINTS in our favor. Our customers say so. Convince yourself by sending us your order. Ask for our free Illustrated Catalog and Price List.

Page & Lyon Mfg. Co., New London, Wis.

Montana, Minnesota, Dakota, and Western Wisconsin Bee-keepers!

You can save freight by ordering of the St. Paul Branch. We have a complete stock of bee-keepers' supplies. Write at once for catalog and obtain our early-order discounts.

BEEES AND QUEENS—Orders booked now for spring delivery.

HONEY AND WAX—We handle honey and wax. Write for particulars.

The A. I. Root Co.

Northwestern Branch,
1024 Mississippi Street,

J. C. Acklin, Mgr., **St. Paul, Minn.**

DO YOU KNOW

That the sale of Dittmer's Foundation has increased so much that we were forced to double our melting capacity in order to fill orders promptly?

There is a Reason for This

It is because Dittmer's Foundation is tough, clear, and transparent, and has the natural color of beeswax.

AGENTS FOR DITTMER'S FOUNDATION:

W. D. Soper.....Jackson, Mich.
Bee and Honey Co.....Beeville, Texas
E. H. Taylor...Welwyn Sta., Herts, Eng.
E. Grainger & Co.....Toronto, Ont., Can.

Our warehouse is well stocked with all kinds of bee-keepers' supplies.

Beeswax always wanted.

Gus Dittmer, Augusta, Wis.

BEE-SUPPLIES

We manufacture every thing needed in the apiary, and carry a large stock and great variety. We assure you the best goods at **LOWEST PRICES**, and our excellent freight facilities enable us to make prompt shipment over fifteen different roads, thereby saving you excessive freight charges as well as time and worry in having goods transferred and damaged. We make the Alternating, Massie, Langstroth, and the Dovetail hive.

Our prices are very reasonable; and, to convince you of such, we will mail you our free illustrated and descriptive catalog and price list upon request. We want every bee-keeper to have our catalog. **SPECIAL DISCOUNTS** now. Write to-day. Address

Kretchmer Mfg. Co., Council Bluffs, Iowa.

Muscatine Produce Co., Muscatine, Iowa.
Trestler Supply Co., Lincoln, Nebr.

Shugart-Ouran Seed Co., Council Bluffs, Iowa.
T. B. Vallette & Son, Salina, Kansas.

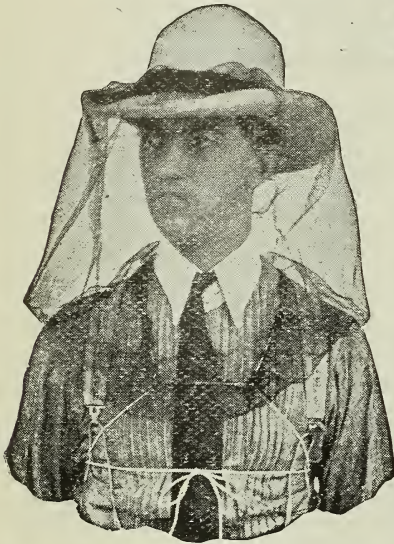

Michigan Distributors

—FOR—

**G. B. Lewis Co.'s Beeware,
Dadant's Foundation.**

With an enormous stock, and the best shipping-point in Michigan, we are in a position to give you the very best service.

ADVANCED BEE-VEIL. Cord arrangement, absolutely bee-proof, best on earth. Made of imported French tulle veiling. Cotton, with silk face. **50 CENTS, POSTPAID.**

A. G. Woodman Co., Grand Rapids, Mich.

Dear Sirs:—Your advanced bee-veil just arrived, and is, as advertised, the best on the market. Find enclosure for ten more veils
Platteville, Wis., April 14, 1906. **N. E. FRANCE.**

A. G. Woodman Co.,
Beeswax Wanted. **Grand Rapids, Mich.**

We Manufacture

the finest, whitest, no-drip basswood **SHIPPING CASE** on the market to-day. Covers and bottoms are of **ONE PIECE**. Everything is **POLISHED** on both sides, and a better case can not be had at any price. We can furnish them in single or carload lots to fit any number or style of section. Large quantities of all the standard sizes on hand. . . . As a special offer we will sell you 25 cases to hold 24 sections, complete with **NAILS, PAPER, and GLASS** at \$4 00. Write for prices on larger quantities. Furnish corrugated paper if desired. We can furnish you with any thing you need in the apiary. Our catalog is free. . . . **PROMPT SHIPMENT and SATISFACTION GUARANTEED.**

Minnesota Bee-supply Company
Nicollet Island, No. 20, Minneapolis, Minnesota

**Bee Supplies. Lewis' Goods at
Factory Prices.**

Best of everything the bee-keeper needs. Large and complete stock. Fine Italian and Caucasian queens. Prompt service. Catalog free. Get our prices before ordering.

C. M. Scott & Co., Indianapolis, Indiana
1004 East Washington Street

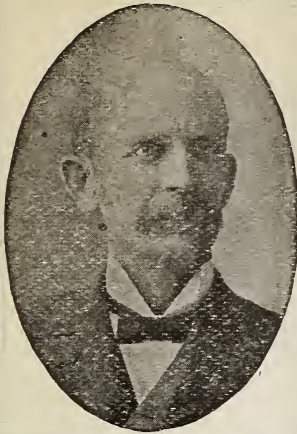

Established 1881

YES!

Same Place 1906

THIS IS THE MAN

WHO HAS HANDLED ROOT'S GOODS ALL THESE YEARS

and is now selling at wholesale and retail at Root's catalog prices. He has carloads of the finest sections, of all kinds and sizes; the Danzenbaker hive, the best single-walled comb-honey hive in use; all kinds of single-walled hives shown in catalog, and supers that match; the Hilton double-walled hive, of which more are used in Michigan than any other. It has stood the test for thirty years. We can't name them all, but send for his 36-page illustrated catalog, and that will tell it all and give prices. Cash or goods in exchange for beeswax at all times of the year.

Geo. E. Hilton, - Fremont, Mich.

BINGHAM
Original
Direct Draft
CLEAN
Bee Smokers

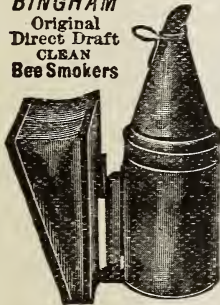

Pat'd 1876, '82, '92 & 1903

Pretty Recognition

A lady to whom I sent a Smoke Engine to order per mail sent this delicate recognition, "I am pleased," and signed her name.

We have made hundreds of thousands of smokers in the last twenty-eight years. They always please and last; don't spit fire; don't go out; don't daub themselves all over. We are the most extensive exclusively bee-smoker makers in the world.

T. F. Bingham - Farwell, Mich.

Chico, California, October 28th, 1905.

Dear Mr. Bingham:- Enclosed find money-order for a honey-knife and smoker. I can't do business without a Bingham Smoke Engine.
J. M. RANKIN.

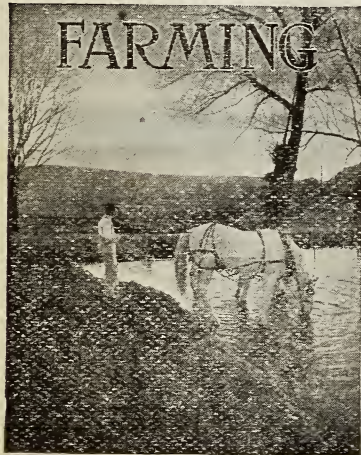

A Delightful Combination

GLEANINGS IN BEE CULTURE, \$1.00 per year.
FARMING MAGAZINE, \$1.00 per year.

PRICE FOR THE TWO, \$1.50.

*Nothing need be said about GLEANINGS. It is the best publication of its class in the world; semi-monthly, 72 to 80 pages, fully illustrated.

†FARMING is a new publication—a beautiful journal for the man who produces from the soil. It is edited and published by the Doubleday-Page Co., the people who edit *Country Life*, *World's Work*, and the *Garden Magazine*, a sufficient guarantee of its merit. Larger than GLEANINGS—fully illustrated. Published monthly.

THIS OFFER IS GOOD, EITHER FOR NEW GLEANINGS SUBSCRIPTIONS OR RENEWALS, BUT MUST BE TAKEN ADVANTAGE OF WITHOUT DELAY.

WE CAN ACCEPT SUBSCRIPTIONS FOR THIS COMBINATION AT THIS SPECIAL RATE ONLY WHEN SENT DIRECT TO THE PUBLISHERS OF GLEANINGS,

The A. I. Root Company, Medina, Ohio.

*Sample copies of either publication will be sent upon request.
†Publications will be sent to two different addresses if desired.

TO SOUTH DAKOTA

The Land of Bread and Butter.

South Dakota is long on wealth and short on people.

Today it presents the best opportunities in America for those who want to get ahead on the Highway to Independence. More than 47,000,000 bushels of corn, more than 47,000,000 bushels of wheat, live stock to the value of \$41,000,000, hay to the value of \$12,000,000, and products of the mines above \$12,000,000, were some of the returns from South Dakota for 1905. With a population of only 450,000, and the annual production of new wealth above \$166,000,000, it can be readily understood why South Dakota people are prosperous and happy. The outlook for 1906 crops is the best South Dakota has ever known.

Why don't you go there and investigate the openings along the new lines of this railway for yourself?

From Chicago, and from many other points in Illinois, Minnesota, Iowa, and Missouri, direct service to South Dakota is offered via the

Chicago, Milwaukee & St. Paul Railway

Its main lines and branch lines fairly gridiron the rich agricultural and stock country of South Dakota. Its mileage in South Dakota is more than 1,200 miles, and by the building of extensions is being rapidly increased.

A NEW LINE IS NOW BEING BUILT from Chamberlain, S. D., to Rapid City, S. D., through Lyman, Stanley, and Pennington Counties. Some of the best opportunities for success are along these new lines. The railway company has NO farm lands for sale or rent. If you are interested, it is worth while to write today for a new book on South Dakota. It will be sent free by return mail.

F. A. MILLER, General Passenger Agent,
CHICAGO.

FAIRS

Why not make the fairs you attend profitable as well as instructive? Make a good honey exhibit and secure awards. Then use your time to advantage soliciting subscriptions to **Gleanings in Bee Culture**.

Gleanings makes very liberal inducements in regular commissions besides large cash prizes. This matter is worth looking into.

County and State Fair Contest Prizes, \$10, \$5, \$3, \$2.

To induce bee-keepers generally to enter our Fair Contest we make the following very liberal prizes over and above the regular commissions earned. For the party sending the largest list of subscribers, \$10; for the second largest, \$5; for third largest list, \$3; for the fourth largest list, \$2; fifth to tenth, a cloth-bound copy of the A B C of Bee Culture. Subject to the following

CONDITIONS

First.—That subscriptions entered in contest are obtained at the fair on dates named in application below, or obtained as results of work during fair.

Third.—That contest closes Nov. 15th, and announcement will be made in Dec. 1st GLEANINGS.

Second.—That yearly subscriptions may be either new or renewal taken at our regular rates. Two trial subscriptions (new names, 6 mos.) are equivalent to one year's subscription.

Fourth.—That only one agent will be appointed for any one fair.

Fifth.—That advertising matter sent is to be carefully distributed to best advantage.

CUT HERE

Date.....

GLEANINGS IN BEE CULTURE, Medina, Ohio:
Fair Contest Department.

Please send agents' terms and enter my name as contestant in Fair Contest. Send to my address, at proper time, advertising matter which will aid me in obtaining subscriptions. I have read conditions, and agree to them.

Date of Fair..... Name.....

Name of Fair..... P. O.....

I can use.....sample copies of Gleanings. State.....

BANKING BY MAIL

Depositors in all parts of the country find our method of sending deposits by mail satisfactory in every way, for the reason that they not only receive

4 PER CENT INTEREST

but they obtain the greatest safety by having their money in the care of a responsible and safe banking institution.

Our booklet describes our methods and management, and explains the advantage of our simple banking-by-mail system. Write for the booklet to-day.

THE SAVINGS DEPOSIT BANK COMPANY

MEDINA, OHIO

A. T. SPITZER, Pres. A. I. ROOT, Vice-pres.
E. B. SPITZER, Cashier.

PENNSYLVANIA

Ours is the largest bee-supply house in the western half of the State. Every thing which the bee-keeper will need is in stock awaiting your order.

ROOT'S GOODS

AT ROOT'S PRICES

You can save time and expense by ordering from us. .

Best shipping facilities. .

Complete stock.

Do not put off ordering to-day what you will urgently need a little later on in the season.

Frank W. Prothero

Successor to Prothero & Arnold

Dubois, Clearfield Co., Pennsylvania

BEE-KEEPERS OF NORTHERN NEW YORK

Buy your shipping-cases, etc., of

A. H. Reeves, Perch River, Jefferson Co., N. Y.

and save freight charges, and time. A complete stock on hand ready for shipment. Comb honey wanted in no-drip cases; also beeswax. . . .

Something New in Honey-jars...

Cook's Square Jar combines a new feature that improves the package and reduces the cost, and is the best and cheapest 1-pound glass package made. Send for circular and full catalog of hives, bees, and useful implements. . .

J. H. M. COOK, 70 Cortlandt St., New York

The Oldest Supply-house in the East, and only Reliable goods sold. 10 cents brings sample jar by mail.

CARNIOLANS our SPECIALTY

WE HAVE been breeding this wonderful race of bees for over twenty years, and during all this time we have been making very careful selections, and we now claim to have one of the best and purest races of Carniolan bees in this country.

They are very gentle, hardy, and prolific; the best of workers; they come out of winter quarters healthier and stronger in bees; they build up very rapidly in the spring, are great comb-builders, and their sealed combs are of snowy whiteness.

Also Breeders of Golden and Leather Italians

No foul brood or other bee-diseases here. Bees and queens guaranteed to arrive in good condition at your postoffice in the United States or Canada. Descriptive price list free.

PRICES.—Untested queen, 75c; six, \$3.90; doz., \$7.00. Tested, \$1.25. Best breeding, \$2.50. Best imported,

F. A. Lockhart & Co.,

\$4.00. One L.-frame nucleus, 75c; two-L.-frame nucleus, \$1.50; three-L.-frame nucleus, \$2.00. Add price of queen wanted to nucleus. Special prices quoted on large orders to dealers.

Banater Bees from Hungary

This wonderful new race of bees takes the lead over all other races, all points considered, that we have seen. The three colonies we are testing are strong in bees; do not offer to swarm; are great honey-gatherers; build snowy white combs, and are very gentle; in fact, no smoke is needed to handle them. They resemble the Carniolans in color, though somewhat darker. We have never seen a race of bees with so many desirable qualities. We shall breed a limited number of queens for sale, and have started a queen-rearing apiary five miles from other bees, and expect to have laying bees ready to mail by July 15. Price \$5.00 each. Pure mating and safe arrival guaranteed.

Lake George, New York

QUEENS

By Return Mail at the Following Prices for the Balance of this Season. Golden or Leather-colored Italian.

Our folks say that your queens are extra fine.
The A. I. Root Co., Medina, Ohio

We have good reports from your stock from time to time.
George W. York & Co., Chicago, Ill.

On every hand I hear good words of Quirin's queens.
B. S. K. Bennett, Los Angeles, Cal.

Your queens did finely. It was one I purchased last year that gave me over 600 pounds of honey.
J. L. Gandy, Humboldt, Neb.

The breeder is surely a very fine one; her daughters do grandly.
Campbell & West, Hartstown, Pa.

I had a queen of you last year which produced bees that beat anything ever seen in this part of the country.
E. L. Messenger, New Haven, Conn.

The nuclei you sent J. A. Adams did just splendidly. Each colony stored at least 75 pounds of honey.
F. P. Merritt, 13 Breckenridge St., Lexington, Ky.

A few years ago I bought a queen from you which proved to be the best I had for years.
H. C. Shirley, Cashier of Liberty Bank, Liberty, S. C.

I have had the pleasure of seeing the results of your queens at Mr. George W. Stanley's apiary, at Scuffletown, Ky., and that is why I am ordering this half-dozen.
C. W. Brenner, Newburg, Ind.

I bought a queen from a neighbor last year who said he got her from you. She made me 193 sections of honey after July 4th—the best my other queens did was 64 sections.
C. E. Woodington, St. Anne, Ill.

With great respect I write to you in regard to your dealing and queens. If you want any references you can refer to me, as I can't recommend you too highly. Your queens are the best I ever saw. I have one hive of bees among my 45 colonies containing a queen from you that \$50.00 will not buy.
Morris Coon, Route 2, Locke, N. Y.

The two-frame nucleus you sent me was put in a hive May 25th. In July I brushed a swarm; had a swarm in August, and took off 75 boxes of honey. I consider this a wonderful record. I had four nuclei from different parts of the country, and yours was far superior to any of them. They are very gentle, easy to handle, hustlers to work. All bees and queens needed by me will hereafter come from Quirin—the queen-breeder, Bellevue, O.
S. A. Peck, Box 124, Northumberland, Pa.

	1	6	12
Select queens.....	75	\$4 00	\$ 7 00
Tested queens.....	1 00	5 00	9 00
Select tested queens.....	1 50	8 00	15 00
Breeders.....	3 00	15 00	
Straight five-band breeders....	5 00		

Safe delivery and satisfaction guaranteed of all queens. Any queen not satisfactory may be returned any time inside of sixty days and another will be sent gratis.

Address all Orders to

Quirin-the-Queen-Breeder
Bellevue, Ohio.

Banat Bees!

The best and gentlest bees known. Bred them four years. Imported queens, \$4.00 each, or \$36 00 per dozen. I will go over there for the queens in August. Send for circular.

L. A. Lawmaster & Sons,
Route 5, Upper Sandusky, Ohio.

H. C. Simpson, Catawba, S. C.

Dealer in

BEE - KEEPERS' SUPPLIES!

Breeder of Italian bees and queens.
Root's Goods a specialty.

Did you Ever

figure the difference in value between a good queen and a poor one?—one colony which brings in a large surplus, and another which, although you spend much more time on it, does not give you any?

Extra Honey Queens

give the best results for the least labor, and are therefore a good investment.

Prices

One.....\$1.00 Six.....\$5.00 Twelve..\$9.00

Francis J. Colahan
Bernardo, San Diego Co., Calif.

When a Thing Needs Doing

NO W is the time to do it. How about those worthless queens? Will you tolerate them for another season, when the best of stock can be obtained so readily? Laws' bees and queens are bringing the best of reports. I could fill many pages of testimonials, but give you only one. Mr. T. P. Robinson, of Bartlett, Texas, says: "Dear Sir.—The car of bees shipped June 20th are now all safely landed, and I have overhauled the entire lot. The bees are from 25 to 40 per cent better than contract, and you ought to hear my wife's exclamations of delight at seeing those fine yellow bees so quietly nestle between the combs at the very approach of smoke. I can certainly recommend you."

Leather and Golden Italians, Holy Lands, and Carniolands—single queen, \$1.00; six for \$5.00. Quantity lots, prices on application.

I also manufacture the Hoffman frames, both new and old style, at \$16.00 per M; single-story eight frame hive complete, 75c; 1½-story for extractor, \$1.00. Price list on application.

W. H. Laws, Beeville, Bee Co., Tex.

Caucasian - and - Italian Bees and Queens

Mr. Walter S. Pouder, Indianapolis, Ind., June 30, 1906, writes: "Friend T., queen arrived to day in good condition. I consider her a very choice specimen of the Caucasian."

Mr. Frank G. Odell, Lincoln, Neb., writes: "The yellow Caucasian queen you sent us is an unusually fine queen and very prolific. We are very much pleased with her."

I can send such queens for \$3 00 each by return mail. Send for circular and price list.

A. E. Titoff, Ioamosa, Calif.

Quality Queens

Are the Best Italians yet.

Send for circular. ☛ ☛ ☛ ☛ ☛ ☛ ☛ ☛

H. H. JEPSON,
182 Friend St., - Boston, Mass.

Italian and Caucasian QUEENS

A special discount is now offered on all queens and bees to be delivered before the close of the season of 1906. Pure stock, pure mating, and excellence of grade guaranteed. Address

Robert B. McCain, R. F. D., Yorkville, Ills.

COLLINGDALE APIARY

J. R. Rambo, Collingdale, Delaware Co., Penn.

Breeder of Caucasian and Golden Italian queens; Italians bred from stock received from Swarthmore; Caucasians bred from an imported queen. Queens reared and mated in separate yards, six miles apart. Satisfaction and safe arrival guaranteed. Prices furnished on application. I am booking orders now for the coming season, and will fill same in rotation as received.

Superior Queens!!!!

(Before June 15) (After June 15)

Italian and Carniolan	
Untested.....	75c; \$8.00 per doz. 60c; \$6.50 per doz.
Tested.....	\$1.00; 11.00 per doz. 75c; 8.00 per doz.
Select Tested...	1.25; 12.00 per doz. 1.00; 11.00 per doz.
Caucasian	
Untested.....	\$1.00; \$11.00 per doz. 75c; \$8.00 per doz.
Tested.....	1.50; 16.00 per doz. 1.00; 11.00 per doz.
Select Tested...	2.00; 20.00 per doz. 1.25; 12.00 per doz.

Write me a postal card for my circular.

Chas. Koeppen, Fredericksburg, Virginia

MOORE'S - STRAIN - OF - ITALIANS

as Red-clover Workers.

L. C. Medkiff, Salem, N. J., says: "I bought an untested queen of you last year, and her bees have filled three comb-honey supers, and did not swarm, while thirteen out of the fifteen other colonies did not get more than half that amount.

"I have queens from six different breeders, and I class yours 100 per cent above them all. Your bees worked very strong on the first crop of red clover. I know they were yours, because I floured them with a dredge-box and watched the hive. They also worked strong on the second crop of red-clover and lima-bean blossoms."

Untested queens, 75c each; six, \$4.00; dozen, \$7.50.

Select untested, \$1.00 each; six, \$5.00; dozen, \$9.00.

Safe arrival and satisfaction guaranteed. Descriptive circular free.

I am now filling orders by return mail, and shall probably be able to do so until the close of the season.

J. P. MOORE, Morgan, Pendleton Co., Ky.

QUEENS DIRECT FROM ITALY

Fine, reliable. English price list sent on application. Beautiful results obtained last year. OUR MOTTO—"Whatsoever ye would that men should do to you, do ye even so to them."

MALAN BROTHERS, Luserna, San Giovanni, Italy.

Queens - Italian - Queens

and bees from Root's Red-clover stock and Golden Italian queens. Better than ever.

Untested.....60c each; six, \$3.50

Select untested.....75c " " 4.00

Tested.....\$1.00 " " 5.00

Select tested.....1.25 " " 5.00

Two-frame nuclei with untested queen..2.00

Orders filled in rotation. . Send orders to

E. A. Simmons, Greenville, Ala.

ITALIAN QUEENS

bred from best of honey-gatherers, either three or five banded or Golden races. Untested, 65c each, 3 for \$2.00, 6 for \$3.75, 12 for 7.25; tested, \$1.00 each, 6 for \$5.00, 12 for \$9.00; select tested, \$1.50 each; breeders, \$300 each.

J. W. Taylor, Beeville, Bee Co., Texas

Orders Filled Promptly by Return Mail

Queens from our fine strain of three-band Italians will not disappoint you. Bees are gentle and the best of honey-gatherers. Queens are large and prolific, and every one guaranteed. Untested, 50c; \$6.00 per dozen. Tested, \$1.00.

J. W. K. SHAW & CO.
Loreauville, Iberia Par., Louisiana

Rose Lawn Queens. Italians - Carniolans - Caucasians.

We thank our friends for the liberal patronage extended to us, and beg to announce that we are prepared to fill orders promptly after July 1.

Our prize offer on honey production still stands, and will be extended to October 1 for those who wish our "Pure Gold" queens.

We call special attention to our Red Clover Italians and Yellow Caucasians, which are worthy the attention of any progressive bee-keeper.

Prices after July 1:
Italians and Carniolans, select, untested, 75c; six, \$4.00
Caucasians, select, untested, \$1.00, six, \$5.00.

Special prices on larger orders and breeding stock on application. Write for catalog.

Rose Lawn Apiaries, Station C, Lincoln, Nebr.

The Best Stock

Nice three-banded Italians that are guaranteed to please, or money refunded. The Robey queens now go to nearly all parts of the globe. They are being used by many of the largest honey-producers of this and other countries, who pronounce them to be very superior strain of bees. I have spent 21 years in building up this strain of bees. Warranted purely mated, in any quantity, 60 cts. each; selected warranted, 75 cts. each.

L. H. Robey, Worthington, W. Va.

Untested Queens!

Golden Italian

75 cts. each; six for \$4.00; an extra fine one for \$1.00. Warranted purely mated and good queens. . . .

J. B. Case, Port Orange, Fla.

Red-clover Queens from Westwood Apiary

will convince you of their superiority over all others. One, two, and three frame nuclei a specialty; also full colonies. Price list sent on application.

Henry Shaffer Westwood, Ohio

From Long-tongued Imported Italians.

Untested, 75c; \$7.50 per dozen. Tested, \$1.25; \$12.00 per dozen. Breeders, \$2.00 to \$3.00. Postal orders drawn on Decatur, Michigan.

E. E. MOTT, Glenwood, Mich.

MOORE'S LONG-TONGUES and GOLDENS

Select untested queens, 75c; six, \$4.00; twelve, \$7.50. Tested, \$1.25; six, \$6.00. Twelve, \$11.00. Best breeders, \$2.50. Safe arrival guaranteed.

W. H. Rails, - - - Orange, Calif.

Red Clover and Italian Queens.

Untested, 65 cents; tested, \$1.00. Select tested, \$1.25; 4-frame nuclei in a nice painted hive, and tested queen, all for \$3.75. "Your bees are swarming on my red clover fields," says G. W. Slaybaugh, York Springs, Pa.

G. ROUTZAHN, Biglerville, Pa.

1906 Italian and Caucasian Queens. Price list now ready. Write E. E. LAWRENCE, Doniphan, Mo.



BEES and QUEENS

BY RETURN MAIL.

The Three-banded
Long-tongued Strain
of Italians.

We are breeding exclusively the above strain of bees, as from years of experience we consider them the best all-round bees that can be had. We have been making, from time to time, very careful selections for the following

Superior Qualities.

Honey-gathering, size of bees, non-swarmer, docility, uniform markings.

Our selection of bees awarded diploma at the PAN-AMERICAN EXPOSITION for being the best bees there. And we guarantee them the equal of any bees anywhere at any price

Quality Our Motto.

1300 colonies to select from.

Untested queens.....	75c; 6, \$4.25; 12,	8.00
Select untested queens.....	1.00; 6, 5.00; 12,	9.90
Tested queens.....	1.00; 6, 6.00; 12,	11.50
Select tested queens.....	1.50.	
Breeding queens,	\$3.00 to \$5.00.	

Yours for best service,

The Victor-Knolle Apiary Co.,
Hondo, Texas.

Golden Queens.

My goldens are yellow from tip to tip. Every queen is worth a dollar, but I have a large number of them and offer them cheap. One, 65 cts.; 3 for \$1 95; 6 for \$3.75; 12 for \$7 50. No finer or better queens can be had at any price. They are reared right. Have had 35 years' experience in rearing queens. I insure satisfaction in every particular. Try at least one of my all-golden queens, and see how promptly I can serve you. Send for circular. It's free.

Daniel Wurth, 1111 North Smith St., San Antonio, Texas

Boston Headquarters

FOR

Bees-Queens-Supplies

H. H. Jepson - 182 Friend St.

Italian Queens of - the - Purest - Strains

I offer this race of queens, bred from select red-clover and five-banded breeders, at the following prices:

Untested, 75c; select untested, \$1.00; tested, \$1.50; select tested, \$2.50. I will guarantee safe arrival and satisfaction.

H. M. PARKER, Jr.

James Island, South Carolina

Same Old Place

is where you get the best of queens; untested, \$1.00; \$4.25 per 6; \$8.00 per dozen. Tested, \$1.50; best breeders, \$5.00. Absolute satisfaction and safe arrival guaranteed. Carniolans, Cyprians, Holy Lands, Italians.

The JENNIE ATCHLEY CO.,

Box 18, Beeville, Bee Co., Tex.

Golden-All-Over

ITALIAN - QUEENS

I have a few choice untested Golden-all-over Italian queens, reared from Pratt stock, by Pratt's methods, and will be able to supply a limited demand for balance of the season at \$1.25 each.

Wm. A. Shuff, Philadelphia, Pa.
4426 Osage Ave.

Queens-Italian-Queens

Bred from the old reliable 3-band stock. Great honey-gatherers, gentle to handle, and not inclined to swarm. Prices for the balance of season, 60c each; \$6 00 per doz. Selected untested, 75c each; \$7.00 per doz. Tested, \$1.00 each; one-half dozen, \$5.00. Address all orders to

W. J. FOREHAND, - Ft. Deposit, Ala.

SUPERIOR STOCK.

I make a specialty of long-tongued Italian red-clover honey-queens. Untested queen, 75 cts. each; 1/2 doz., \$3.00; tested, \$1.00; 1/2 doz., \$5.00. Bees for business is my motto.

FRED. LEININGER, Ft. Jennings, O.

Yellow from Tip to Tip !!!

My Adel bees and queens are very handsome. Every queen a breeder, and guaranteed to produce golden queens and beautiful bees; non-swarmer, very gentle, and hustlers for honey. Each queen, \$1. Catalog ready.

H. ALLEY, - Wenham, Mass.

MINNESOTA-BRED QUEENS.



Try our Northern-bred queens—nothing finer; three-banded and golden Italian queens, untested, 75 cts.; tested, \$1.50. Hardy and prolific. We want your orders, and will fill them by return mail, and guarantee safe arrival and satisfaction. Write for circular to
MENNIE & FENTON,
Pine Island - Minnesota.

I. J. STRINGHAM

OF 105 PARK PLACE

New York

furnishes every thing a bee-keeper uses. Strong colony of bees, with tested Italian queen, in Dov'd hive complete, \$8.00; in a chaff hive, \$9.50. Three-frame nucleus, with Italian queen, \$4.00. Silk-faced bee-veil, 40 cts. postpaid. Italian queens, 85 cts. Catalog of bee-supplies free.

Apiaries, Glen Cove, Long Island.

Wants and Exchange.

Notices will be inserted under this head at 15 cts. per line. Advertisements intended for this department should not exceed five lines, and you must say you want your advertisement in this department or we will not be responsible for errors. You can have the notice as many lines as you like, but all over five lines will cost you according to our regular rates. This department is intended only for bona-fide exchanges. Exchanges for cash or for price lists, or notices offering articles for sale, will be charged our regular rates of 20 cts. per line, and they will be put in other departments. We can not be responsible for dissatisfaction arising from these "swaps."

WANTED.—Bee supplies in exchange for 300 colonies of bees. See ad. elsewhere. Manufacturers write me if interested. LEO F. HANEGAN, Glenwood, Wis.

WANTED.—Refuse from the wax-extractor, or slumgum. State quantity and price.

OREL L. HERSHISER,
301 Huntington Ave., Buffalo, N. Y.

WANTED.—Ten bushels alsike clover-seed or a good mixture of alsike and timothy. No mustard or other noxious seeds wanted. Give price and quality. HENRY STEWART, Prophetstown, Ill.

WANTED.—To exchange a paid-up scholarship in the electrical department of Scranton Correspondence School (I. S. C.) with drafting outfit, for bees, supplies, hives, etc.

W. D. K. DEUEL,
323 Adam St., Tonawanda, N. Y.

WANTED.—Utah, Nevada, and California honey. We are now contracting with bee-keepers for our year's supply, small lots as well as carload lots. We pay cash, or, to all who prefer bee-supplies in payment, we give extremely low figures. We have the agency for The A. I. Root Co.'s goods in Utah, and buy by the carload.

SUPERIOR HONEY CO.,
F. W. Redfield, Mgr. Ogden, Utah.

Help Wanted.

WANTED.—A cook in a private family of three. Good home for respectable woman. Good wages paid. Address

JOHN RICK,
434 Oley St., Reading, Pa.

For Sale.

FOR SALE.—400 cols. pure Italian bees in lots to suit. Write for prices. F. A. GRAY, Redwood Falls, Minn.

FOR SALE.—Bees and bee-supplies.
J. GOBEL, Glenwood, St. Croix Co., Wis.

FOR SALE.—Untested Italian queens at 60c; two for \$1.00; tested, \$1.00 each. MRS. J. W. BACON,
Waterloo, Seneca Co., N. Y.

FOR SALE.—Bee-keepers' supplies. Root's goods. Root's prices. Free catalog. F. R. DANIELS,
117 Florence St., Springfield, Mass.

FOR SALE.—My apiary complete in the great irrigated alfalfa belt; no failure yet. See GLEANINGS of Dec. 15, 1903, page 1051. C. K. C., Lovelock, Nev.

FOR SALE.—If you want an illustrated and descriptive catalog of bee-keepers' supplies for 1906 send your name and address to FRANK S. STEPHENS,
(Root's Goods.) Paden City, W. Va.

FOR SALE. 275 colonies of bees in good condition. Also can locate you on first-class homestead claim under Gunnison tunnel, one of Uncle Sam's biggest reclamation projects. Address Box 782, Montrose, Col.

FOR SALE.—170 colonies of bees in eight and ten frame hives; honey house on wagon, uncapping-tank, honey-tank, four-frame extractor; mare, colt, horse, cow, 200 chickens, 10 acres of land with improvements. Rt. 3. Mrs. T. HARRIS Visalia, Cal.

FOR SALE.—First-class second-hand 5-gallon honey-cans, two in the case OREL L. HERSHISER,
301 Huntington Ave., Buffalo, N. Y.

FOR SALE.—One dollar pays for three queens, red-clover strain, balance season. J. F. MICHAEL, Winchester, Ind.

FOR SALE.—400 acres choice citrus fruit land. ALBERT GUNN, Cespedes, Camaguey Prov., Cuba.

FOR SALE.—Red-clover—J. P. Moore strain—mated to choice drones. Select untested, \$1.00 each, six for \$5.00. WALTER M. PARRISH, Lawrence, Kan.

FOR SALE.—\$200 will buy 100 full colonies and 10 nuclei, strong; Italians and hybrids. G. P. HOWELL 6101 Dauphine St., New Orleans, La.

FOR SALE.—Queens. I breed a superior strain of fine golden-all-over Italians. Ask for prices. T. L. MCMURRAY, Ravenswood, W. Va.

FOR SALE.—Special sale of sections—Wisconsin bass-wood—equal to the best, No. 1, \$4.20; No. 2, \$3.70. Root Dovetailed and Danz. comb-honey hives, and all kinds of supplies on hand. Italian queens and bees. H. S. DUBY, St. Anne, Ills.

FOR SALE.—500 colonies of bees located in the best sweet-clover belt in the U. S. Will take \$1500 for the outfit. Reason for wanting to sell, too much other business. If I do not sell shall want a good man to run them next season. W. N. CANNON, Greenville, Ala.

FOR SALE. Or trade, a power blacksmith-shop, five-room dwelling, and other out-buildings, in a good locality for a good smith; all shop-tools and stock included. I. S. SONAFRANK, McGrawsville, Ind.

FOR SALE.—One No. 15 two frame Cowan honey-extractor for \$9.00; one Dadant uncapping-can, \$7.50—used very little and good as new; 50 full colonies of Italian bees in ten-frame Root hives at \$4.00 each. EARL BAKER, 2467 Auburn Av., Sta. B, Toledo, O.

FOR SALE.—600 stands of bees in first-class shape for comb honey, in four yards, two to four miles from town; good house at each hard; in sweet-clover and alfalfa belt; no failure in seven years, and under big Gunnison Tunnel project. Reason for selling, poor health. Address Box 772, Montrose, Colo.

FOR SALE.—A 15-acre fruit-farm close to a county-seat town of 4000 inhabitants; one acre each of strawberries, raspberries, blackberries, and grapes; 130 cherry, 200 plum, 400 peach trees in bearing; good improvements and good schools. An ideal place for a fruit-grower and bee-keeper. Plenty of white clover. For further particulars address

L. C. CLARK, Hiawatha, Brown Co., Kan.

Poultry Offers.

FOR SALE.—Choice poultry. Ten leading varieties for the farmer or the fancier. Circulars free. A. H. DUFF, Larned, Kansas.

FOR SALE.—Alger's rose-comb Brown Leghorns hold the world's record; first at Chicago International, St. Louis World's Fair, exposition at Portland, Oregon. Italian bees—Root strain direct Flemish Giant hares, very large. Red Belgians from 16-lb. buck. Get circulars. FRED ALGER, Waukau, Wis.

KEEP YOUR EGGS

all summer while prices are low, and sell next winter at a good profit. Write for our plan; it will interest you.

T. T. POULTRY CO., Springfield, Ohio.

GET RID OF LICE.

For 25 cts. we send formula that never fails to exterminate lice. Costs less than 8c per lb. to make. Guaranteed. Used by many leading poultrymen.

T. T. POULTRY CO., Springfield, Ohio.

HONEY - JARS!

A neat package is a great help to the sale of your extracted honey. A glass jar is the favorite for many markets. Some retail trade demands one style and some another. We can supply you with what you want.

Simplex Honey-jars

This is a new jar with glass screw-top and rubber gasket fitted to the taper screw on jar, which seals absolutely airtight. We consider it the handsomest jar we sell for one pound of honey. Your honey in these jars is sure to attract attention and have a ready sale in any grocery.

We are now prepared to offer Simplex jars in partitioned cases of two dozen each, ready to reship, when filled, at \$1.00 per case; ten-case lots or over, at 95 cts.; fifty-case lots at 90 cts. We can ship either from Medina, Chicago, New York, Philadelphia, and, after Sept. 1, from Mechanic Falls, Me.

No. 25 Jars

This is our standard jar—holding one pound of honey. We have sold this jar for years, and in larger quantities than any other honey-package we ever handled. It has opal cap with rubber ring and tin screw rim. Put up in re shipping-cases of two dozen. Prices same as Simplex jars quoted above.

Tip-top Honey-jars

This is a new-style jar sealed with a rubber ring under rim of a glass top held securely with spring-top fastener. This fastener is applied to a great variety of bottles and jars used for different purposes. We have selected two styles among them all as being most suitable for honey. The one and two pound square jars may be had with spring top fastening instead of cork at 75c per gross extra. We furnish in two sizes. Half-pound, 45c per dozen; gross, \$4.50. One-pound, 50c per dozen; gross, \$5.00.

Tumblers

There seems to be an increasing demand for a cheap tumbler to put up a

half-pound of honey to retail at 10 cts. We have secured a stock of such tumblers at a price which enables us to offer them at \$4.00 per barrel of 24 dozen. This is less than 1½ cts. apiece. For less than barrel lots we can not repack them for less than 25 cts. a dozen; or we will put them up 4 dozen to the case with partitions ready to reship when filled, at \$1 00 a case; 10-case lots at 95c.

Mason Fruit-jars

These are very largely used for canning fruit, and are often used for honey as well. As we buy them by the carload, we can make the following prices at Medina, all put up complete with porcelain-lined caps and rubbers, in cases of one dozen:

SIZE	Doz.	6 doz	12 doz.
Pint	\$ 52	\$3 00	\$5 75
Quart	55	3 10	6 00
½-gallon	75	4 10	8 00

Triumph wrench for Mason caps, 15c each; by mail, 25 cts.

Ball's waxed rings, better than rubbers, 5c dozen; postage 3c.

Sample Mailing-blocks

Price each, 6c; by mail, 8c.

These are small wide-mouthed glass bottles, which hold ½ oz., with cork, put up in a mailing-block, with top which screws on and is easily removed.

Honey-labels

We print them in large and small lots; over fifty styles. Write for sample-book and prices.

Prompt Shipment

All of our branches and agents are well supplied. Write the one nearest you.

The A. I. Root Company

Medina, Ohio, U. S. A.

Chicago, Ill.
Philadelphia, Pa.
New York City

Syracuse, N. Y.
Mechanic Fs., Me.
St. Paul, Minn.

Washington, D. C.
Havana, Cuba
Kingston, Jamaica

PATENTS.

Twenty-five Years' Practice.

PRINDLE & WILLIAMSON,

Patent practice in Patent Office and Courts.
Second National Bank Bldg., Washington, D. C.
Patent counsel of The A. I. Root Co.

Mexican Palm-leaf Hat, 50 c.



Hand-woven by Mexicans in Mexico, from palm fiber; double weave, durable, and light weight, with colored design in brim. It retails at \$1.00; sent postpaid for 50 c. to introduce our Mexican hats and drawn-work. Same hat plain, 40 c.; both for 7 c. Large, medium, and small sizes. Fine for fishing, camping, seashore, and gardening. Hat booklet free.

The Francis E. Lester Co., Dept. A A, Mesilla Park, N. M.



Fruit Driers, Evaporators.

Prices from \$3.50 up.
You can save all your fruit, berries, sweet corn, etc., and are a first-class kitchen safe for keeping pies, cakes, etc. Address D. STUTZMAN, Ligonier, Ind.

SPRAY PUMPS

"TAKE OFF YOUR HAT TO THE MYERS"

MYERS
The Pump that pumps easy and throws a full flow. The cheapest pump is the best pump, that's a Myers. Pumps, Hay Tools & Barn Door Hangers. Send for catalog and prices.
F. E. Myers & Bro., Ashland, Ohio.



ASHLAND PUMP AND HAY TOOL WORKS

No. 602 Bee-keepers' Pocket-Knife Tool Kit.

Made in America

Every one has use for a Knife, Reamer, File, Saw, Chisel, or Screwdriver. This outfit is practical, yet so small, being contained in a Leather Pocket-Book 4 1/4 x 3 1/4 inches, is, by carrying it in your pocket, always at hand for immediate use, whether Camping, Boating, Teaming, Driving, in the Shop, Factory, Office Store Warehouse, Automobile, on the Farm, Bicycle, or around the Home.

Any Tool firmly attached or detached to the Pocket-Knife in a second.

Sent postpaid on receipt of price, \$2.25.

Use it five days and if not satisfactory return it and I will refund your money.

U. J. ULERY CO., No. 7 Warren St., New York, N. Y.

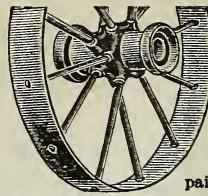

STEEL WHEELS

with wide tires double the usefulness of the farm wagon. We furnish them any size to fit any axle. Cheaper than repairing old wheels. Catalogue free.

EMPIRE MFG. CO., Box 91A Quincy, Ill.



FENCE Strongest Made

Made of High Carbon coiled wire. We have no agents. Sell direct to user at factory prices on 30 days free trial. We pay all freight. Catalog shows 37 styles and heights of farm and poultry fence. It's free. Buy direct. Write today

COILED SPRING FENCE CO.
Box 101 WINCHESTER, INDIANA.

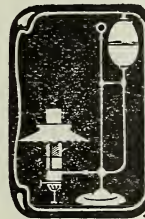

THE "BEST" LIGHT

Portable 100-Candle Power light. Every lamp warranted. The most brilliant, economical light made. No grease, dirt, odor or smoke. AGENTS WANTED EVERYWHERE.

THE BEST LIGHT COMPANY,
306 E. 5th St., Canton, O.

You Need It.

- If you have only a few chickens;
- If you are at all interested in poultry;
- If you are breeding for fancy points;
- If you cater to the market trade;
- If you are in the business on large scale, you need

Ohio Poultry Journal

the paper published in the interest of the farmer, beginner, and small breeder, with plenty of pointers for the experienced fancier. Each month is especially edited for the needs of that special season of the year. Regular price is 50 cts. a AT HALF PRICE year, but we offer it for a short time to introduce it to readers of Gleanings. Send only 25 cts. and get it a year; or, if you send us \$1 for a year's subscription to Gleanings in Bee Culture, we will send you Ohio Poultry Journal for a year free. Address Ohio Poultry Journal, Dept. 14, Dayton, Ohio.

\$1.00 WILL PAY FOR TEN YEARS!

120 copies and no less than 3840 pages (size 8x11 1/4 inches) of valuable poultry, pigeon, and pet-stock reading, costing us thousands of dollars to procure. Also your name and address in the "Poultry-breeders' Directory" for 10 years; revised yearly. Send \$1.00 to-day, and address

Poultry Item, Sellersville, Bucks Co., Pennsylvania

DO YOU RAISE CHICKENS?

If so, you will find The Poultry Gazette a welcome monthly visitor to your home. A down-to-date, practical poultry magazine that is the acknowledged leader of all Western poultry papers; ably edited; profusely illustrated. Subscribe now, while the price is only 25 cts. a year. If you have poultry to sell, The Poultry Gazette can sell it for you.

The Poultry Gazette, Dept. B, Clay Center, Neb.

Save Money on Your
BEE-SUPPLIES

I ship several cars of
the celebrated Root
goods to Kansas City

every year, and save hun-
dreds of dollars for our cus-
tomers in Kansas, Nebras-
ka, Missouri, etc. Let me
save you a few dollars on
your goods. Write me at
Main Office. Catalog, in-
formation, etc., sent free.

Carl F. Buck

Augusta - : - Kansas

Italian  **Queens**

Untested Queens, 75 cts. each; six for \$4.25.
Select Untested, \$1.00. . . . Tested, \$1.00.
Breeding Queens, \$3.00.

**Bee-keepers'
Supplies**

Send for our new revised catalog,
Root's Supplies are what we handle.
A full line always on hand.
We give you prompt service.
Freight rates are reasonable.

John Nebel & Son Supply Co.
High Hill, Montgomery Co., Missouri

At St. Louis

A complete line of Root's Bee-
keepers' Supplies. Unexcelled
shipping facilities for reaching
the Middle West.

ADDRESS

**Blanke & Hauk
Supply Co.**

202-204 Market Street
St. Louis, Mo.

ALSO MANUFACTURER OF AND DEALER IN

**Dairymen's
and Poultrymen's
Supplies**

Low freight. . . . Prompt shipments.
Factory prices. . . . Write for catalog.

Send Us Your Order

THE
**COLORADO
BEE-KEEPER**

IS THE man we are interested in,
whether he has one swarm or five
hundred. If you are that man, we
are talking to you.

The goods we sell were made in
Ohio. You live in Colorado.

The point is this:

We cut out the distance, and bring
your goods home to you—and they are
Root's Goods too.

Just now we are interested in get-
ting our catalog into the hands of
every bee-keeper. It is YOURS for
the asking.

Your order to us, small or large,
means prompt service and Root Goods.

**The L. A. Watkins
Merchandise Company**
Denver, Colorado

The Best ^{is} Always The Cheapest

We have been furnishing bee-keepers all over the World with Supplies for over 25 YEARS, and no complaints.

Our PRICES are as low as any, while the QUALITY of our goods is HIGHEST. Catalog and price list free. We have for 16 years published THE AMERICAN BEE KEEPER, an illustrated 32-page monthly, edited by two of the most experienced bee-keepers in America. Fifty cents a year. Sample copy free.

The W. T. Falconer Mfg. Co., Jamestown, N. Y.

Look, Utah and Idaho

A Complete Line of The A. I. Root Company's Bee-supplies at Factory Prices

We have paid the freight to Ogden, and they cost you no more than if you buy them at Medina, Ohio. Do not delay ordering, as the honey-flow is at full blast. We also have all sizes cans and shipping-cases. Parties having honey for sale will please write us.

Superior Honey Company, Ogden, Utah
F. W. Redfield, Manager

Dadant's Foundation

It Excels

Every Inch Equal to Sample

Beauty! Purity! Firmness!
No sagging; no loss.
Twenty-eighth Year.
We Guarantee Satisfaction.
Wax Worked into Foundation.

~~~~~  
**Bee-supplies of All Kinds**

~~~~~  
Beeswax wanted at all times.
Send for Our 1906 Catalog.

~~~~~  
Dadant & Sons, Hamilton, Ill.

## Root Goods

for the West

New catalog now ready to mail. Write to-day. Remember I have been in the business over 20 years, and carry the largest stock in the West. Many thousands of dollars' worth of goods now on hand ready for distribution.

Why put up with infer or goods when you may as well have the best? They cost you no more. In many cases I can save you money. In all cases I give the most for the money, quality considered.

They are the ROOT GOODS, which I sell here at ROOT FACTORY PRICES and DISCOUNTS, My shipping facilities are unsurpassed anywhere. Practically all points are reached by direct lines, thus insuring the lowest freight rates.

~~~~~  
Jos. Nysewander, Des Moines, Iowa
565, 567 West Seventh Street